

SSC18-WKX-02

On-Orbit Demonstrations of Robust Autonomous Operations on CubeSat

Toshihiro Obata, Shinichi Nakasuka, Yoshihide Aoyanagi, Takeshi Matsumoto
The University of Tokyo
RM110 Engineering Bldg. No.7 7-3-1 Hongo, Bunkyo-ku, Tokyo JAPAN; +81-3-5841-8679
toshi.obata.space@gmail.com

Seiko Shirasaka
Keio University
Yokohama, Kanagawa 223-8526 Japan; +81-45-564-2581
shirasaka@sdm.keio.ac.jp

ABSTRACT

As we accumulate experiences of satellite developments, we clearly recognize the importance of successful operations and difficulty to achieve them. There are many anomalous events in orbit especially for small satellites. It is costly or impossible to consider all anomalies in advance. The autonomous operation functions, we have developed, can operate the satellite without operators and achieve operation intents. The functions have the satellite behavior (state) models and the given operation intents. They generate the on-board operation procedures from the behavior models and execute them. Even if the status may not transit as expected due to anomalies, they can re-recognize the new status, generate the operation procedures again, and achieve the operation intents robustly. We have demonstrated the autonomous operation functions on a 3U CubeSat called TRICOM-1R that was launched by the newly developed and dedicated small satellite launcher SS-520 on 3rd Feb. 2018. The autonomous functions worked correctly and tried turning on the cameras without any predetermined operation procedures during the very first cycle of the orbit. The demonstration of them has successfully completed. We have several CubeSats and small satellites now in development and we will implement the upgraded version of the autonomous functions on them.

BACKGROUND*New Satellite Systems that Create New Needs for Satellite Operations*

As we accumulate experiences of satellite developments, we clearly recognize the importance of successful operations and difficulty to achieve them. Currently, the operation of many satellites is carried out under the circumstances in which ground operators understand and manage the condition perfectly after sufficiently preparing necessary operation procedures.

Satellite operations are getting more difficult. One of the reasons is emergence of satellite constellations. Operations of a large number (100 and more) of satellites constellation are not same as a conventional operation of a single satellite. Such an operation becomes complicated, because each satellite behaves differently, we need to conduct different operations for individual satellites, and the satellites may have different anomalies. As for the current actual constellation, the complexity of the operations is suppressed by simplifying the satellites and their operations [1]. However, as requirements for the satellites and the satellite operations become more sophisticated in the near future, it is obvious that

complexity of satellite functions and their operations will become larger. Even a simple operation needs huge efforts when it is applied to many satellites [2]. This is because it is necessary to create and verify procedures used for operations, assign ground stations, assign operators, and build the operation plans including all of them.

We are developing satellites to realize the mission called “on-demand observation”. This is characterized by launching a satellite to the optimal orbit for the observation of a disaster area after the disaster occurred. Immediately after the satellite is separated from the launcher, the satellite observes the affected area and downlink the observed image to the nearest ground station.

As a result, it is possible to observe the disaster areas in several hours after the occurrence of the disaster, which usually takes from half a day to several days. We consider this system important as a disaster countermeasure in countries including Japan with many natural disasters.

ImPACT (Impulsing PARadigm Change through disruptive Technologies) program is a Japanese high-risk and high-impact research and development

program that aims to bring industry and society revolutionary changes by innovative science and technology such as cyber, chemistry, material and robotics with big funds. 16 programs have been selected and our responsive observation satellite program is one of them.

Our program aims to develop an on-demand earth observation system with a SAR (Synthetic Aperture Radar) satellite that is prepared, stored beforehand, launched quickly as requested. The satellite will acquire data necessary to detect or monitor disasters like closed roads, collapsed infrastructures, affected area by flood, landslide and so on (Figure 1). Those affected areas are in most cases covered by clouds caused by rain or hurricane, as they are typical reasons of disaster. Disaster may happen even during nighttime. SAR satellite that can observe target area through clouds and during nighttime, and that has less dependency on ground infrastructure around affected area is adequate for this purpose [3].

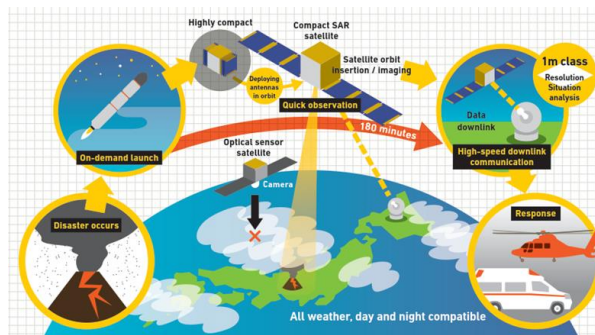

Figure 1: Concept of On-Demand Observation

In order to realize this mission, autonomous preparation and checkout of the functions for the observation, autonomous recognition of the orbital position and timing, and autonomous execution of the sequence necessary for observation is necessary. In other words, from the launch of the satellite to the observation of the affected area and the downlink of the satellite data, there is no support from the ground operators. The satellite must judge autonomously and deal with the deviation of the orbit caused by rockets and the uncertainty of the operating condition of each equipment.

The University of Tokyo is currently constructing a constellation of a CubeSats constellation and supporting a small SAR satellites constellation. The CubeSats constellation is a system that provides inexpensive IoT services in cooperation with developing countries and universities. The first launch of the CubeSat has succeeded in February this year. We are developing at least two more CubeSats that will be launched in 2019.

The small SAR satellite is 140 kg class and 1-3 m resolution. It aims to provide frequent data for 365 days under any weather conditions and during day and night. The constellation has 6 to 20 satellites. We are currently developing EM and our plan to launch the satellites is starting from the end of 2019. The on-demand observation using this same satellite will be realized, then.

Strong Motivation to Achieve the Operation Intents

Achieving the operations intents under such circumstances where it is anticipated that operation difficulty will increase is a strong motivation of this research.

We usually require perfect operation plan and perfect operation procedures to achieve the operation intents. We implement as many actions against uncertainties including component anomalies as possible into the operation plan and operation procedures. However, designing them needs huge efforts and there is no perfect ones essentially. When any unexpected or unconsidered event occurs, the operators are going take actions to avoid the risk of the expensive satellite loss. So, the operators will change the satellite mode to the safe hold mode and conduct a thorough investigation of the event. After the investigation, they will make a recovery plan to the normal operation and verify it. Finally the satellite will return to normal operation, after the execution of the recovery plan. This means it sometimes takes time and huge efforts to achieve the operation intents with conventional operation method avoiding the risks.

Now, the situation is changing. In the case of a satellite constellation, the number of anomalies occurring on satellites in the constellation will be bigger, while the impact of individual satellites loss is less. Conversely, less operators are able to involve operations of individual satellites. As a result, autonomous operation both during normal and anomaly operations is preferable with accepting unexpected events and without depending on operators.

Moreover, as for the on-demand observation, it is not expected to operate the satellite by ground operators in the first place. Therefore, a certain degree of risk tolerance is a prerequisite. Observing targets is sometimes more important than the satellite safety in the on-demand observation. In other words, even if there is a risk that battery power will be consumed more than usual due to the anomaly, the priority is on the observation of a target.

So, it is more preferable to achieve the operation intents robustly with accepting unexpected events rather than

control the satellite behavior perfectly and safely in these satellite systems.

In areas other than space developments, there are examples where we rely more on machines that make plans and decisions than human operators by accepting unexpected events and risks. Driving a car is an example (Figure 2). The driver sets the destination, but the car navigation system determines the detailed route. The car navigation system recognizes the environmental conditions even while driving, and modify the route at any time. This makes it possible to arrive at the destination more reliably and quickly against changes in the environment (ex. traffic jams, unexpected road closure, mistake of the driver) than the era when the driver relied on his or her memo of the route listed in advance.

We expect same outcome on the satellite operations as the car navigation systems have introduced on the driving a car.



Figure 2: Dynamic Routing of Car Navigation System

In the previous researches, handling the anomaly is one of the main topic of an autonomy in the satellite operations [4][5]. Our research is also in common with efforts for autonomous satellite operation, dealing with anomalies, responding to unexpected events, and maximizing results.

However, previous researches don't consider the recent changes of operational risk allowance, as in the case of current satellite constellations and on-demand observations. The autonomy in the previous research is the one emphasizes making satellites safe by identifying the cause of the anomaly from behaviors and taking necessary recovery operations. This is because, as discussed above, there was a policy to minimize risk in satellite operations.

There are few researches from the viewpoint of realizing operation intents robustly. Our research focuses on realization of operation intents rather than identifying the cause of the anomalies or developing the flawless operation plans or operation procedures.

ISSUES OF CURRENT SATELLITE OPERATIONS

When we operate satellites, we usually build the operation plans based on the satellite design information while considering the space environment and constraints of satellites. Examples of such constraints include sun / earth direction, orbit, temperature, power, data volume, attitude, timing, state of equipments at the time of operations.

The operation plans are valid while the assumed constraints are satisfied. Conversely, if the assumed constraints are not satisfied, the operation plans may be invalid. For example, when the ON / OFF state of the camera or the voltage of the battery are different from the assumption, the operations may not apply the operation plans as they are.

We performed the analysis of the reasons for the modifications from the original operation plans. Figure 2 shows the analysis results of the modifications on the TRICOM-1R operation plans for 120 ground operations over 40 days. TRICOM-1R is the 3U CubeSat manufactured by the University of Tokyo and launched on February 3rd 2018.

We operate the satellite in accordance with the operation plans made on the previous day. However, there are many modifications on the actual operations from the operation plans caused by several reasons.

43% of the operations required the plan modifications in these 40 days. This is mainly because of components instability caused by the satellite orbit that is highly elliptical one (perigee 190km, apogee 1800km) and where the Van Allen radiation belt affects the behavior of the components. The computers sometimes freeze or occasionally reset.

When the assumptions are not satisfied, it is necessary to modify the operation plans and implement recovery operation, in order to achieve the initial operation intents. For example, we must restart the frozen computer at first, to start the intended operations. The operators must build recovery operation plans that can realize the original intents within the constraints, based on the latest situational awareness and satellite design information.

This kind of operation is difficult, because it is necessary to consider recovery operation plans under

the satellite conditions different from the normal ones in a shorter time than the time of planning the normal operation plan. Only operators who have satellite design information and experiences can cope with this. These issues are not only for CubeSats or SmallSat, but also for the bigger satellite like Metop [2].

The autonomic functions we developed is aimed at autonomously coping with anomalies by autonomous modifications of operation plans in the on-board computer.

The effect of the autonomous functions are very big. The result of the analysis shows that we may avoid 74% of the modifications of the operation plans, when we implement the autonomous functions that enables to fix these unpredicted modifications of the satellite status. The autonomous functions we developed can cope with component error (27%), unpredicted status change (32%) and communication problem (15%). They can restart the anomalous computers and other components, find the adequate operation procedures for the recovery from the unpredicted status change. They can conduct these autonomous operations without any ground communications.

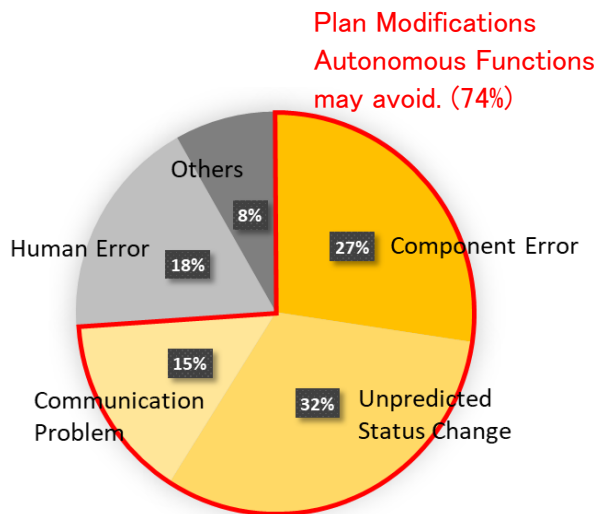

Figure 3: Analysis Results of Modification Reasons on the Operation Plan

AUTONOMOUS FUNCTIONS FOR INTENT-ORIENTED ROBUST OPERATIONS

What we propose is the method for a more efficient and robust approach to operate satellites with autonomous functions. The intent-oriented operation procedures generation eliminates the issues of operations and

enables the robustness to cope with unexpected anomalies.

The autonomous functions have state transition functions and search functions of state transitions (Figure 4). These functions require a database that represents satellite behaviors based on state transitions. These functions are generic regardless of satellite behaviors. State transition model can represent most of the behaviors. For example, the step-by-step operation sequences and FDIR functions can be formalized as a state transitions. Therefore, changing the database changes satellite behaviors. Conversely, if you want to express or realize different satellite behaviors, you can do so by changing the database without changing the functions.

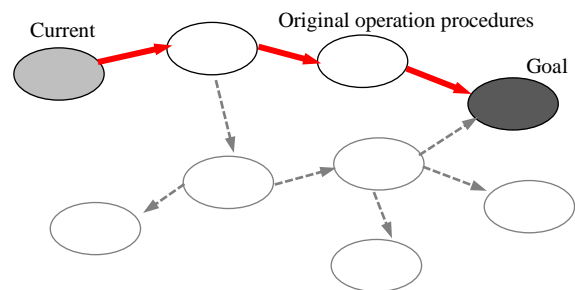

(a) Original Operation

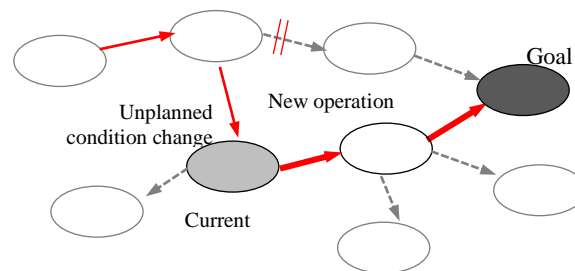

(b) New Operation

Figure 4: State Transition Model for Autonomous Functions

A state transition is caused by commands and/or telemetries. Behaviors of the satellite functions can be represented by a collection of state transition groups. State transitions interact with each other. In other words, one command or telemetry may cause multiple state transitions. Telemetry changed by one state transition may be a trigger for another state transitions.

Model-based autonomy

NASA and MIT have long applied autonomous functions called Livingstone and Burton to satellites [6][7]. They also have models to estimate latest situations and reason of the anomalies. We use the model to generate the operation procedures. By generating necessary operation procedures flexibly according to the latest circumstances, it surely achieves the intents by repeatedly attempting the trial. This enhances the robustness of operations and we call it ‘intent-oriented’ operation procedures generation. Some kind of concept for the ground testing is existing [8], however there is still no on-orbit demonstrations for actual satellite operations.

Algorithms of the functions

The algorithms of the state transition functions are:

- Prediction of state transitions by the occurrence of the events such as command executions
- Detection of occurrence of the predicted state transitions
- Requesting the search of the state transitions, when the predicted state transition does not occur
- Decision that the state has reached the goal (state that achieves the operation intents)

The algorithms of the search functions of state transition are:

- Search of the state transitions from the current to the goal
- Extraction of the necessary commands and telemetries to achieve the searched state transitions
- Extraction of the state transitions caused by the searched state transitions
- Decision that the state has reached the goal

Evaluation functions are used to select a specific state transition from multiple possible ones as a result of searching them. The distance to the goal, the execution numbers of the same state transitions and etc. are parameters for the evaluation functions.

Moreover, by changing to an evaluation function that suppresses or promotes a specific state transition, it is possible to make the state transition easy to occur. For example, if the battery capacity level is high, the

autonomous functions can select the state transitions that consume more power and achieve the intent shorter period, however if the battery capacity level is getting low, they can select more power efficient state transitions.

Contents of the Database

The database holds groups of state definitions, state transitions, state definitions, telemetry and command definitions. Modification of the database makes it possible to modify the behavior of the satellite without modifying the autonomous functions. That is, by adding a new state transition definition, a new behavior is generated.

The database is relatively easy to implement than the operation procedures that we usually use for the operations. As the information in the database is mainly design information like definition of state transitions of the satellite functions, commands, telemetries, we can implement them as the database at a necessary and sufficient level for operations, and reduce the labor of designing and verifying for the operations.

ON-ORBIT DEMONSTRATION

We have conducted an orbital demonstration of intent-oriented robust operations by the autonomous functions using 3U CubeSat. This CubeSat is TRICOM-1R (Figure 5), explained in the previous chapter, and demonstrated the store and forward mission. This is the first satellite of the CubeSats constellation described in Background chapter. It is a satellite that provides IoT (Internet of the Things) service for collecting short messages from many ground sensors and transmitting them to ground stations. The features of this system is that the uplink from the ground sensor can be achieved with weak radio signal (20mW) that license is not necessary. We use LoRa as the uplink modulation. This makes it possible to inexpensively integrate device information without using an existing expensive satellite communication network even in places where no ground infrastructure such as mobile phone networks is existing.

The application of IoT service of the constellation is, for example, periodic monitoring of the environment such as water quality and water level, detection of disaster events such as landslides, acquisition of position information of moving targets, monitoring of facilities, etc.

Currently, we deployed the ground transmitters in various places such as Rwanda, as well as several places in Japan, They actually operate as we expected (Figure 6).



Figure 5: TRICOM-1R



Figure 6: Location of the Ground Transmitters

By the way, the launcher of the CubeSat, SS-520, is registered as the smallest orbital rocket by the Guinness World Records®. The rocket launched TRICOM-1R into the orbit whose perigee is 190km and apogee is 1800km.

TRICOM-1R with Autonomous Functions

The system block diagram of TRICOM-1R is shown in Figure 7. The primary mission of TRICOM-1R is the main camera and the receiver for the store and forward message service. The sub-cameras are the secondary mission. Power subsystem includes solar cells mounted on the surface of satellites, batteries and power control circuits that generate electric power. It has a main computer (COMM) and a mission computer (MOBC) that controls the mission functions. For the attitude control, it has gyroscopes, acceleration sensors, magnetic sensors, magnetic torquers, and a single reaction wheel. For the communication between the

ground stations, it has a UHF band transceiver. We also have GNSSR (Global Navigation Satellite System Receiver) to estimate the position of the satellite.

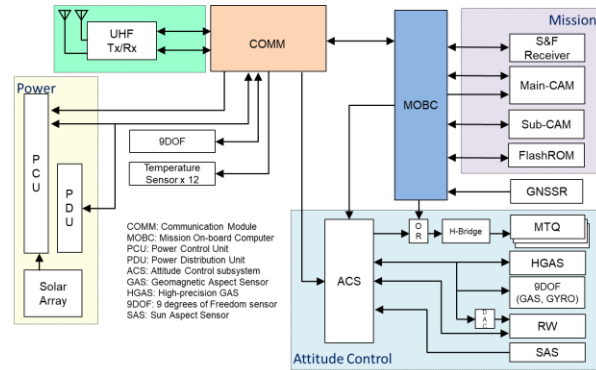

Figure 7: System Block Diagram of TRICOM-1R

We have developed and implemented the autonomous functions as one of the applications of the mission computer (MOBC). MOBC can acquire information of each device via COMM and can control ON / OFF of the functions and so on. Then, the autonomous functions can estimate the satellite state from predefined telemetry information and instruct COMM to take actions to realize the given intents.

The predefined telemetry information used by the autonomous functions to estimate the satellite state is as shown in Table 1. The commands that the autonomous functions can generate and send to COMM for execution are shown in Table 2.

Table 1: Predefined Telemetries for the Autonomous Functions

No.	Categories	Telemetry Items
1	Sub-Camera	ON/OFF
2		Current
3		Image Captured
4	Power	Battery Voltage
5-9		Solar Array Output Current×5
10, 11		Solar Array Output Voltage×2
12	Orbit	Estimation Status
13, 14		Position (Latitude, Longitude)
15		GNSSR ON/OFF
16-18	Attitude Control	Angular Rate×3
19		Reaction Wheel ON/OFF
20		Reaction Wheel Speed
21	System	Timer

Table 2: Predefined Commands for the Autonomous Functions

No.	Categories	Command Items
1, 2	Sub-Camera	ON/OFF
3, 4		Data Transmission ENA, DIS
5, 6	Orbit	GNSSR ON, OFF
7	Attitude Control	Angular Rate Target (Z axis)
8, 9		Reaction Wheel ON, OFF
10		Reaction Wheel Speed
11, 12		Attitude Control ENA, DIS
13	System	Autonomous Function OFF

On-Demand Operations by Autonomous Functions

We demonstrated the on-demand operations by the following steps (Figure 8).

1. Separation of the satellite from the launcher
2. Preparation for image capture, enabling the autonomous functions, estimating the satellite position
3. Target image capture, when the autonomous functions estimated that the satellite pass over the target
4. Data transmission of the captured images to the ground station

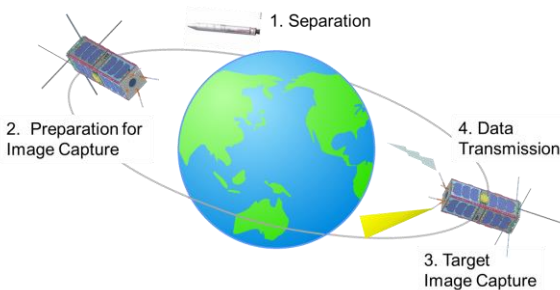

Figure 8: Demonstration of the On-Demand Operations

To achieve these steps, we usually prepare an operation plan in advance to cope with anomalous satellite behaviors including anomalies of battery voltage, components, orbit determination status, temporary malfunctions of capturing images and data transmission. However, it takes much effort to design and verify the flowchart that is robust enough against anomalies to achieve the intents. Moreover, a limited communication time and limited information to understand the satellite status makes the operation hard, although the ground operators try to operate the satellite as defined in the flowchart.

To achieve the on-demand operation, it is not acceptable. All of these steps occurs during the first cycle of the orbit after the satellite separation from the launcher and there is no ground stations. Many unpredicted situations and unstable components may induce the anomalous satellite behaviors during the period.

For the demonstration of the on-demand operation, the autonomous functions used Status of Sub-Camera, Battery Voltage, Orbit Estimation Status, Orbit Position and Timer. Four state transitions were implemented as follows.

MODE1: Orbit Estimated or not

MODE2: Position is Over the target or not

MODE3: Sub-Camera Status (Figure 9)

MODE4: Battery Status

MODE 1 estimates whether the orbit of the satellite is estimated from the state of GNSSR. MODE 2 estimates whether the current satellite orbit position has reached over the imaging target or not. The decision is made by GNSSR, if the GNSSR completed the estimation of the satellite position. Otherwise the decision is made by the timer. MODE 3 estimates the state of the Sub-Camera. The state transition of the Sub-Camera is defined as OFF → ON → STANDBY → END in normal, and the command to achieve this is generated (Figure. 8). MODE 4 constantly monitors the voltage of the battery, and stops all sequences when the voltage becomes lower than a certain level.

All of the above functions are realized by database installed in the on-board software. By changing the database, it is also possible to add other functions. For example:

- RW is turned on only when the attitude rate is equal to or higher than a certain rate and the power is kept in the normal state. The camera is turned on after the attitude rate has decreased. After the camera captures the image, then RW and the camera are turned off.
- Eclipse and sunshine were estimated from generated power of solar cell. In the eclipse, the equipment is turned off to conserve electric power. During the sunshine, observation is carried out with GNSSR, RW, and Sub-Camera.

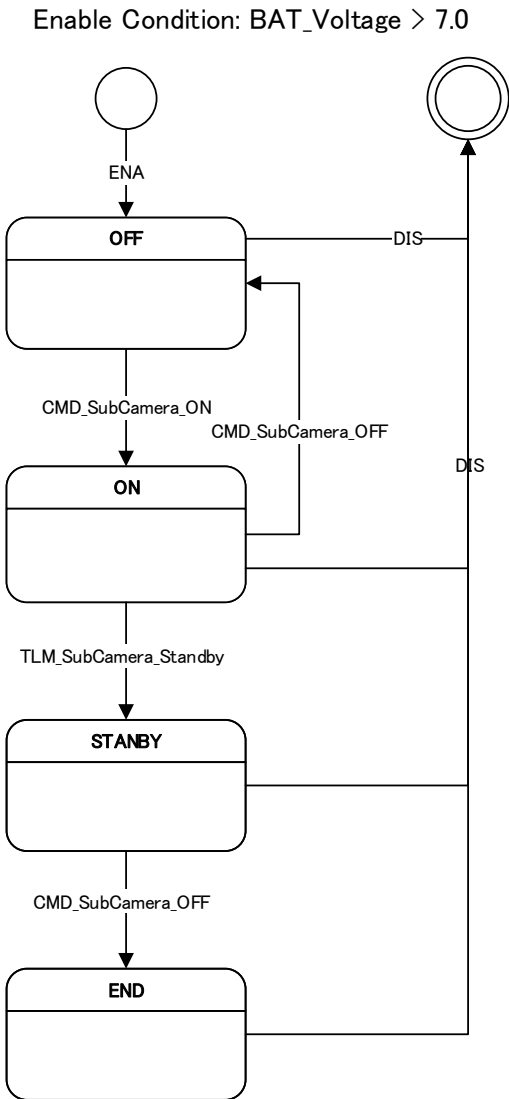

Figure 9: Model of MODE3 (Sub-Camera Status)

Verification of the Autonomous Functions

The verification of the autonomous functions was carried out in 4 steps.

First, we verified the algorithms of autonomous functions under a software environment. We conducted functional verifications using several simple state transitions database, like valve, driver and pump model of the thrusters and attitude control system model to achieve the sun pointing and earth pointing. We confirmed that the modification of the database can modify the behavior of the satellite and the application of the autonomous functions can accept the modification of the database.

Then, we build the C-code application of the autonomous functions from the verified algorithms.

After that, we set database for the on-demand operation, and carried out over 10,000 cases of simulations to verify the database for the on-demand operation as well as the application software of autonomous functions. We set GNSSR error, Sub-Camera ON error, image capture failure, battery voltage error and etc. as the anomaly cases for the simulation. We confirmed that the autonomous functions correctly detect these anomalies and recover from them. For example, in the image capture failure case, when the completion of the image capture sequence can't be confirmed, we confirmed that the autonomous functions turn off the Sub-Camera once and then turn it on again until the completion of the successful capture of the image. Also, when the battery voltage error occurred, we confirmed that all autonomous functions normally disabled.

The database used during the software environment verification is converted to the C-code one.

We verified the application of the autonomous functions and database under a hardware-in-the-loop environment. We implemented them with the other flight software to the on-board computer board. We performed a hardware-in-the-loop test for several days, with the same anomaly cases as we set during the verification under the software environment. The result was as same as the simulation under the software environment. We confirmed we successfully implemented the application and the database.

Furthermore, we conducted the verification on the FM and successfully confirmed the normal operation of the autonomous functions by the following tests:

- (1) On-demand operation under the condition that GNSSR doesn't estimate the satellite orbit
- (2) On-demand operation under the condition that GNSSR estimates the satellite orbit
- (3) On-demand operation under the condition of intermittent GNSSR estimation status
- (4) On-demand operation when the Sub-Camera has a temporary anomaly preventing from capturing images
- (5) Operation to disable the autonomous functions by setting the battery level low

Finally, the autonomous functions are ready for the on-orbit demonstration.

On-Orbit Demonstration

We demonstrated the autonomous functions on-orbit twice so far. The autonomous functions themselves worked successfully as designed.

The autonomous functions started as scheduled immediately after the separation of the satellite from the launcher. At this time, the rotation rate of the satellite was so large (about $600^\circ / \text{s}$). The autonomous functions decided to use the timer to determine the timing to capture the target image, because the orbit estimation state of GNSSR was not stable. Then, they generate command to turn on Sub-Camera at the timing of capturing the target image. However, the Sub-Camera ON command was not actually executed, because of an unstable communication conditions inside the satellite right after the predicted computer reset. It was confirmed that the autonomous functions correctly generate the Sub-Camera ON commands several times per minute, because they tried to achieve the given intents that is turning on the Sub-Camera.

On February 11th, we performed the second demonstration of on-demand operation. This time, GNSSR estimated the satellite orbit normally. Then, the autonomous functions turned on Sub-Camera, confirmed Sub-Camera captured images, and turned OFF Sub-Camera to finish the on-demand operation. We successfully confirmed the normal operation of the on-demand operation.

Further Demonstration Plan

We have a plan to demonstrate other operation scenarios using a backup flight CubeSat in the University of Tokyo as well as the on-orbit demonstration that we have done. We would like to perform the autonomous operations using the generate power of solar array panel, gyros and reaction wheels, for example.

We also have a plan to upgrade the application to the more useful one. We will implement a simulation functions in the autonomous functions. The simulation function will simulate power, data storage and attitude of the satellite according to commands. The autonomous functions reflect the simulation result to evaluation functions to select the adequate state transitions. This enables more sophisticated command generation considering restrictions of power, data storage and attitude of the satellite as well as the achievement of the operation intents. We will also update the command interface of the autonomous functions to enable ground operators' easy modification of the database for the autonomous functions, although the satellite is working on-orbit.

We have at least two more cubesats already decided to develop and launch from the International Space Station. We will finish their development until November 2018.

We are also developing the small SAR satellite slated to launch after October 2019. Then, we will build a constellation of at least six SAR satellite to achieve a frequent monitoring of disaster, economic activities, and so on.

Our plan is to implement the autonomous functions to all of these satellite, demonstrate the autonomous functions and upgrade them continuously to achieve more efficient and robust operations.

CONCLUSION

This paper describes the intent-oriented autonomous functions required for operations that are more robust. These autonomous functions are applicable for any satellite including mega satellite constellations and 'on-demand' observation.

The autonomous functions have the explicit behavior models of the satellite and can search the operation procedures to achieve the intents. Ground operators can set the intents not the operation procedures to the satellite, and the autonomous functions create operation procedures according to the situation including anomalies. This is more robust way of satellite operations to handle anomalies than ever.

We have developed the autonomous functions and successfully demonstrated on-orbit in February 2018. We will continuously upgrade them to achieve more efficient and robust operations.

ACKNOWLEDGMENTS

This work was performed by the University of Tokyo under contract with the Impulsing Paradigm Change through Disruptive Technologies (ImPACT) Program, Cabinet Office, Government of Japan. The 3U cubesat, TRICOM-1R, which was used for the demonstration of this work is built by the fund from Ministry of Economy, Trade and Industry.

REFERENCE

- [1] R. Zimmerman, D. Doan, L. Leung, J. Mason, N. Parsons, and K. Shahid, "Commissioning the World's Largest Satellite Constellation," *AIAA/USU Conf. Small Satell.*, no. 609, 2017.
- [2] R. Dyer, R. Porta, F. Perlik, F. Ares, E. Valido, and A. Loretucci, "Metop-SG Operations Concept – From Spacecraft," no. June, pp. 1–11, 2018.

- [3] H. Saito, "SSC17-IX-01 Development Status of Compact X-band Synthetic Aperture Radar Compatible with a 100kg-class SAR Satellite and Its Future Plan," in *31th Annual AIAA/USU Conference on Small Satellites*, 2017.
- [4] A. Wander and R. Förstner, "Innovative fault detection, isolation and recovery strategies on-board spacecraft: State of the art and research challenges," *Dtsch. Luft- und Raumfahrtkongress 2012*, pp. 1–9, 2012.
- [5] B. Bittner *et al.*, "An integrated process for FDIR design in aerospace," *Lect. Notes Comput. Sci. (including Subser. Lect. Notes Artif. Intell. Lect. Notes Bioinformatics)*, vol. 8822, pp. 82–95, 2014.
- [6] J. Kurien and P. Nayak, "Back to the Future with Consistency-based Trajectory Tracking," *AAAI/IAAI Conf.*, pp. 370–377, 2000.
- [7] S. Chien *et al.*, "A Demonstration of Robust Planning and Scheduling in the Techsat-21 Autonomous Sciencecraft Constellation," *Sixth Eur. Conf. Plan.*, pp. 276–283, 2013.
- [8] T. Yamada, "Generic Software for Spacecraft Testing and Operations," no. November, pp. 1–7, 2006.