

## Payload Configuration, Integration and Testing of the Deformable Mirror Demonstration Mission (DeMi) CubeSat

Jennifer Gubner  
 Wellesley College, Massachusetts Institute of Technology  
 21 Wellesley College Road, Wellesley, MA  
 jgubner@wellesley.edu

**Faculty Advisor:** Kerri Cahoy  
 Massachusetts Institute of Technology

### ABSTRACT

Adaptive optics is an imaging technique that has been used on many ground based telescopes to improve image resolution and reduce the effects of atmospheric turbulence. While adaptive optics has known uses on the ground, applying this technique to space telescopes has major advantages for exoplanet imaging, inter-satellite laser communication, high energy systems, and other military applications.

The Deformable Mirror Demonstration Mission (DeMi) is a 6U CubeSat, that will demonstrate the use of adaptive optics, specifically a microelectromechanical system (MEMS) deformable mirror, in space. Not only will the DeMi mission characterize the deformable mirror on-orbit, the mission will also demonstrate deformable mirror control using closed loop image plane sensing and wavefront sensing on internal and external light sources. DeMi uses COTS components like Thorlabs mirrors, Pixelink complementary metal-oxide-semiconductor cameras, and a Boston Micromachines Corporation “multi” deformable mirror.

DeMi is currently in the optical integration and testing stage. The payload design and assembly is being tested by assembling 3D printed payload components. Optical alignment and configuration is being tested by mounting the optical components to the 3D printed payload assembly. Current and future testing will inform payload design and payload assembly plan changes. DeMi is expected to launch winter of 2019.

### INTRODUCTION

Adaptive optics (AO) have been commonly used on ground based telescopes, such as the Keck I and II telescopes<sup>1</sup>, to correct for the negative impacts that atmospheric turbulence has on astronomical imaging. While AO is commonly known to have uses on ground based telescopes, it also has applications on space telescopes. AO can be a critical difference in reaching the necessary contrast, of  $10^{-10}$ , to image Earth-like exoplanets.<sup>2</sup> It allows for corrections of wavefront error caused by optical imperfections and thermal distortions. These correction capabilities allow launches of cheaper optics, improve imaging resolution, and have applications for optical amplification in intersatellite communication and various military projects.

#### *Mission Overview*

The Deformable Mirror Demonstration Mission (DeMi) is a 6U CubeSat mission created to demonstrate the use of AO, specifically a Microelectromechanical System (MEMS) deformable mirror (DM), in space. MEMS

DMs have not previously been demonstrated on long duration space missions. One of DeMi’s main objectives is to demonstrate the AO capabilities in space using a closed loop wavefront control system.<sup>3</sup>

DeMi’s other mission objectives are to characterize the MEMS DM on-orbit and to image a star, or other astronomical object, using the DM to improve the point spread function.

#### *Optical Design Overview*

The payload, which will be flown on a Blue Canyon Technologies 6U XB6 bus, uses a series of off-axis parabolic mirrors (OAPs), field mirrors, complementary metal-oxide semiconductor (CMOS) cameras, a Shack-Hartmann Wavefront Sensor (SHWFS) and a Boston Micromachines Corporation 140 actuator MEMS DM, to demonstrate the wavefront correction capabilities.

#### *Software Overview*

The DeMi mission will demonstrate the correctional capabilities of AO in space by employing the use of

closed loop wavefront correcting software. The software will work by taking the data from the SHWFS or the CMOS image sensor and using it to correct the shape of the deformable mirror. The new mirror shape will then be fed into the system and the loop will process again with the new image or wavefront. This wavefront correction software will run on payload computers that are independent from the XB6 bus.

### Paper Organization

In this paper, I begin by with the Optical Layout section to discuss, in more detail, the optical configuration of DeMi. I have included subsections to provide more detailed information on the important optical components. These subsections include a Deformable Mirror section, a Complementary Metal-oxide Semiconductor (CMOS) Camera section, and a Shack-Hartmann Wavefront Sensor section. Following the Optical Layout section, I discuss the concept of operations for the mission. The section, Concept of Operations, includes general information about the mission as well as details about the internal and external observations of the mission. In the next section I discuss payload integration and testing, followed by plans for future work and testing.

### OPTICAL LAYOUT

The payload for DeMi works by directing the light source, either internal or external, through a beamsplitter and using one beam for the closed loop wavefront correction and one beam for the imaging. Figure 1 shows the configuration of the optics in the payload.

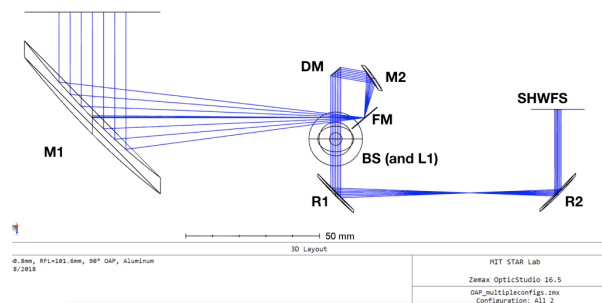

**Figure 1: Optical configuration of DeMi**

The first mirror, M1, is a 2" 90° Thorlabs OAP with a 4" focal length that takes the light from the external observation and directs it in to the payload. The light gets focused by the OAP and reflects off of the field

mirror, labeled FM in the diagram. The field mirror has an embedded single mode fiber, coupled with a 635 nm laser diode, that will be used for the internal observations of the mission. The fiber is off axis by about 0.2 degrees, and provides a near diffraction-limited spot. The next mirror in the configuration is M2, which is a smaller 90° OAP cut down to 8.5 mm diameter with a focal length of 15 mm. This OAP collimates the light and sends it to the DM. The DM will correct the incoming wavefront and send the corrected wavefront through the rest of the payload.

The DM reflects the wavefront through a beam splitter, labeled BS, which sends one wavefront down through the base of the payload and one through to the back of the payload. The downward reflected wavefront is captured by a CMOS camera, labeled L1.

The back-moving wavefront is directed through a set of ½" diameter, 90°, 2" focal length Thorlabs OAPs, R1 and R2, to resize and redirect the beam. This OAP relay sends the wavefront to the SHWFS to inform the wavefront correction loop.

### Deformable Mirror

The role of a DM in an AO system is to correct the wavefront for any aberrations or imperfections detected by the wavefront sensor. A DM accomplishes this goal by deforming its shape into a conjugate of the detected wavefront.

There are two main kinds of DMs, segmented and continuous. Segmented mirrors have individual flat surface mirrors attached to each actuator. A continuous DM uses a continuous face-sheet mirror over the actuators.

The DM on DeMi is a 140 actuator BMC multi with 5.5 μm stroke and a 4.95 mm aperture. The MEMS DMs made by BMC use electrodes and variable supplied voltages to move the actuators of the mirror.<sup>4</sup> The 140 actuator multi DM was chosen for its high actuator count, large stroke, and good correctional capabilities, all within a reasonable cost.

### Complementary Metal-oxide Semiconductor (CMOS) Camera

There are two CMOS cameras used on the DeMi payload, and both play major roles. One is used as a camera to capture the image from the observation and to direct the image plane wavefront sensing. The other is used in the SHWFS. The CMOS cameras used on DeMi are PL-D775MU-BL COTS cameras from Pixelink, shown in Figure 2. These Pixelink cameras have 5 megapixel resolution and can perform at 15 fps

at full resolution.<sup>5</sup> The cameras come with a flex cable that directs the heat generated by the readout electronics away from the optics.



**Figure 2: Pixelink CMOS camera**

### *Shack-Hartmann Wavefront Sensor*

Shack-Hartmann wavefront sensors use a lenslet array to divide up the incoming beam of light and focus the divided beams on to a CMOS camera. The direction and shape of the incoming beam can be determined based on the displacement of the centroids from each beam in the divided array. An example of the SHWFS results for a distorted wavefront is shown in Figure 3.

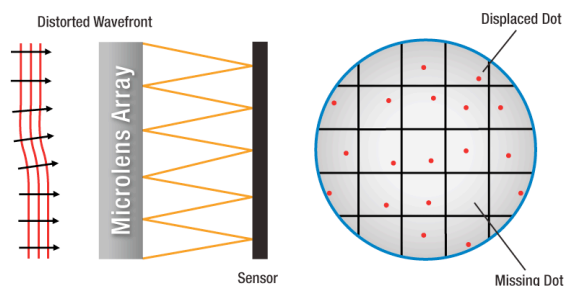

**Figure 3: SHWFS simulation<sup>6</sup>**

The SHWFS used for DeMi has a lenslet array, Thorlabs MLA 150-5C(-M), that has approximately 4 lenslets per DM actuator spacing, and uses one of the

Pixelink CMOS cameras mentioned above to capture the centroids from the lenslets.

The SHWFS will use MIT written software to determine centroid positioning and send appropriate commands to the DM.

For preliminary testing of the optics configuration, we used a Thorlabs WFS150-5C.

### **CONCEPT OF OPERATIONS**

DeMi will be deployed in to a ~500 km, mid-latitude inclination, circular low Earth orbit and complete both internal and external observations, as described in more detail below, during its approximately one year lifetime. The internal observations will be used to characterize the DM and to test the control loops. The external observations will demonstrate the use of the AO system astronomical targets. I have worked significantly on defining and outlining the concept of operations, and have broken the modes down to include more details about mission procedures.

Before each operation, the spacecraft will perform several checks to ensure that the spacecraft can safely and correctly perform its desired functions. These checks will be different for internal and external operations, as they have different performance requirements. After the checks, the spacecraft will power on the required components for the specific mode of operation. The spacecraft will then test voltage and current to the components and finish by taking baseline measurements and image frames.

### *Internal Modes of Operation*

For the internal operation, several system checks need to be done to ensure successful operation of DeMi. The spacecraft needs to ensure that the internal temperature, attitude control, data storage capacity and power supply to the payload fit the requirements. If the system checks pass, then the payload can power on the necessary components. For internal observations, the following components need to be powered on:

- Laser
- DM
- CMOS Camera
- SHWFS

During the internal operations, DeMi will perform three different demonstrations. Each of these demonstrations will use the internal laser source to illuminate the DM and take measurements. These three demonstrations are:

- Test all DM actuators to full displacement

- Run the wavefront correction loop on the internal laser
- Run the image plane wavefront correction loop on the internal laser

The first operational mode will characterize the DM by testing each individual actuator to full displacement. For each actuator, we will record a wavefront measurement and an image plane measurement.

The second operational mode tests the standard wavefront correction loop. This operational mode will use the SHWFS to measure the wavefront and will run a closed loop correction between the SHWFS and the DM.

The third operational mode will test the image plane wavefront sensing. This mode will use the CMOS camera in a closed loop with the DM to correct the wavefront from the internal source. The DM corrections will be based on a built up library of image plane DM actuator influence functions.

Figure 4 outlines the steps required to complete the internal observations.

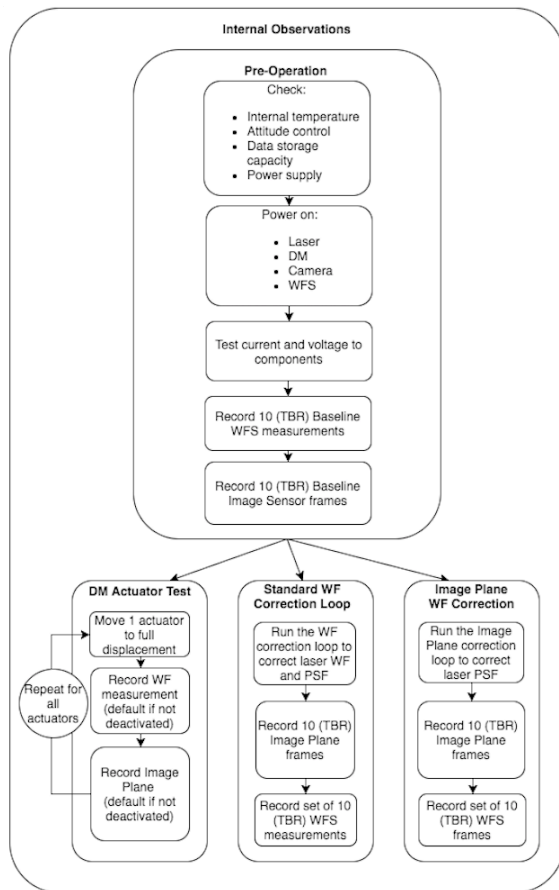

Figure 4: Internal modes of operation

### External Mode of Operation

For external observations, the spacecraft needs to perform more system checks. In addition to the system checks needed for internal observations, the spacecraft also needs to check spacecraft pointing and stability as well as spacecraft position relative to eclipse. Once system checks are complete, the spacecraft will need to power on the DM, CMOS camera and the SHWFS.

The external mode of operation will perform astronomical observations while testing the wavefront correction loop. This mode will use the external aperture to look at the light source from stars and use the closed loop wavefront correction system to demonstrate the correctional capabilities.

Figure 5 outlines the steps required to complete external observation successfully.

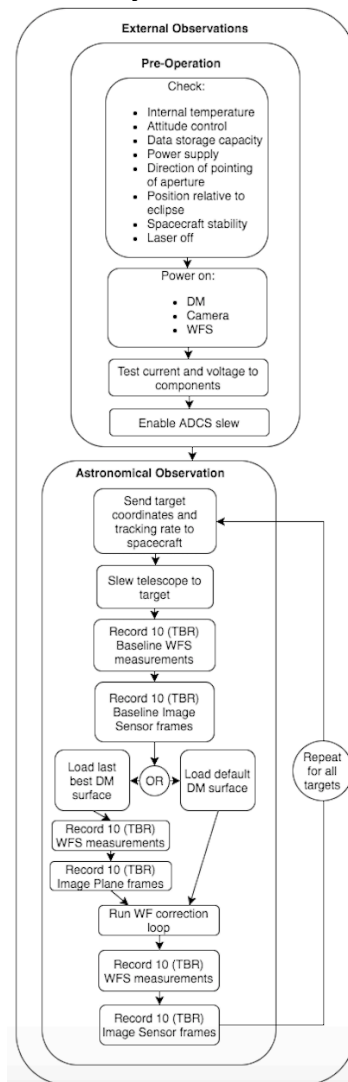

Figure 5: External operational mode



## PAYLOAD INTEGRATION AND TESTING

To test optomechanical design and optical configuration of the payload, I have put together 3D printed models of the payload. The initial test was a full print of the payload with all components already included in the print. This test was to check for sizing and spacing of the payload components.

For the next test, we individually 3D printed all of the components for payload assembly. Using fasteners and fine adjusters I practiced assembling the payload and checked for any design flaws. Figure 6 shows the assembled 3D printed payload without mounted optics. The model is approximately 30 cm in length and 10 cm in width.

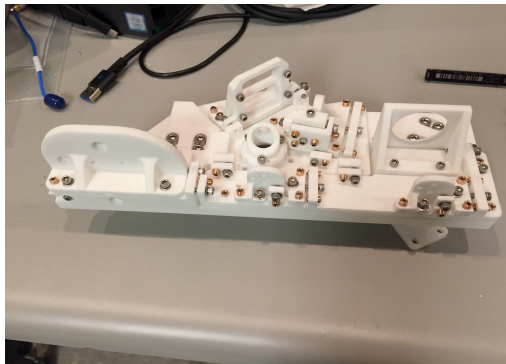

**Figure 6: 3D printed payload assembly**

After checking the payload assembly, I mounted the optics to the model to check clearances and spacing. Figure 7 shows the payload assembly with some of the mounted optics.

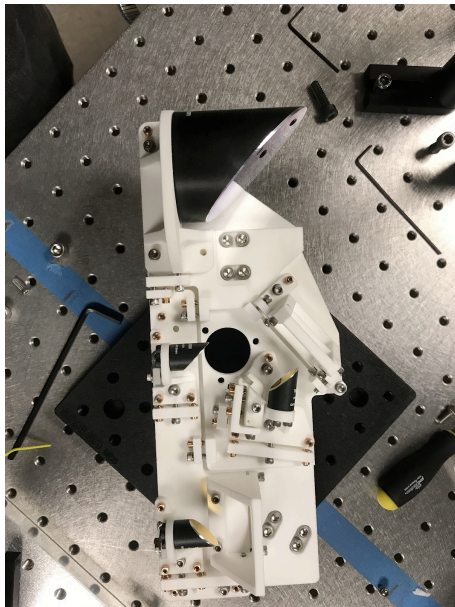

**Figure 7: 3D printed payload assembly with optics**

## FUTURE WORK

After making modifications to improve and refine the design based on lessons learned during the practice with the 3D printed model and optics, we sent out the corrected design to be 3D printed. These new 3D printed components have just arrived to the lab and I will begin testing of the assembly procedures and optics spacing. After the new model is assembled, I will then test complete optical alignment of the payload and revise the assembly plan to ensure smooth flight payload assembly. The complete assembly plan and optical alignment will then be tested on an aluminum model of the payload before final payload integration.

Before the payload delivery, we will complete additional testing and characterization of the individual optics components. These tests will include characterization of the DM using an interferometer, calibration and thermal testing of the CMOS cameras, and SHWFS performance testing.

We also need to finalize wavefront correction software and make refinements to the mission operation plans before launch in the winter of 2019.

## ACKNOWLEDGEMENTS

I would like to thank the Defense Advanced Research Projects Agency (DARPA) for funding DeMi and acknowledge Annie Marinan for the original DeMi mission idea proposed in her PhD thesis. I would like to thank Bobby Holden, Gregory Allan, and Warren Grunwald for their large contributions to the development of DeMi and would like to acknowledge the rest of MIT STAR Lab for their contributions to the project. I would also like to extend my sincere appreciation to Professor Kerri Cahoy and Dr. Ewan Douglas for their continued support throughout this project.

## REFERENCES

1. Max, C., "Introduction to Adaptive Optics and Its History." *UC Observatories*, NSF Center for Adaptive Optics, Jan. 2001, [www.ucolick.org/~max/History\\_AO\\_Max.htm](http://www.ucolick.org/~max/History_AO_Max.htm).
2. Traub, W. A., and Oppenheimer, B. R. 2010. "Direct Imaging of Exoplanets." In *Exoplanets*, 111–156. Tucson, AZ, USA: University of Arizona Press.
3. Cahoy, K., Marinan, A., Novak, B., Kerr, C., Webber, M., "Wavefront control in space with MEMS deformable mirrors", *Proc. SPIE 8617, MEMS Adaptive Optics VII*, 861708 (5 March 2013);

doi:10.1117/12.2005685; <https://doi.org/10.1117/12.2005685>.

4. “AO Tutorial.” Thorlabs, [www.thorlabs.com/newgrouppage9.cfm?objectgroup\\_id=3208](http://www.thorlabs.com/newgrouppage9.cfm?objectgroup_id=3208). Accessed April 16, 2018
5. “PL-D775.” Pixelink, [http://files.pixelink.com/datasheets/PL-D700/Datasheet\\_PL-D775.pdf](http://files.pixelink.com/datasheets/PL-D700/Datasheet_PL-D775.pdf). Accessed April 16, 2018.
6. “SH Tutorial.” Thorlabs, [www.thorlabs.com/newgrouppage9.cfm?objectgroup\\_id=2946](http://www.thorlabs.com/newgrouppage9.cfm?objectgroup_id=2946).