

## SSC18-IV-05

**Bolstering Mission Success: Lessons Learned for Small Satellite Developers Adhering to Manned Spaceflight Requirements**

Henry B. Martin, Conor G. L. Brown, Tristan A. Prejean, Nathan D. Daniels  
NanoRacks LLC  
1424 K St NW, Washington DC, 20009; (859) 559-7322  
hbmartin@nanoracks.com

**ABSTRACT**

This paper is meant to impart critical knowledge to new and upcoming spacecraft developers (universities, high schools, research centers, young commercial companies, etc.) regarding lessons learned that they can implement to create successful spacecraft missions. This perspective comes from NanoRacks, a “space access provider”, where we’ve gained enormous expertise on how to design and build to requirements driven by human-rated spaceflight. As we all know, operating in space is only half of the battle.

**INTRODUCTION**

Developing small spacecraft has provided unprecedented educational experiences for thousands of students, from elementary school students to doctoral candidates. The ability to design, build, launch, and operate a spacecraft under a relatively small budget and comparatively short timeline has enormous benefits to all facets of aerospace. Small spacecraft have also proven to be legitimate research platforms, providing scientists and startup companies invaluable data, and avenues to produce viable commercial products. The community around small satellites has spurred an established commercial sector dedicated to the engineering of these modern marvels.

Having flown over 220 satellites to low-Earth orbit (LEO) through the International Space Station (ISS) Program, NanoRacks has garnered valuable insight on how to comply with manned spaceflight requirements. These satellites fly with NanoRacks through a variety of methods: international collaborations such as the QB-50 Program, grant awards from the NASA Launch Service Program (LSP), technology development projects from Department of Defense (DoD), research programs from government/NASA centers, and an array of commercial companies such as Planet and Spire Global.

NanoRacks has strived to ensure requirements are launch vehicle agnostic for spacecraft flying to the International Space Station. In the background, we have worked to get the manned spaceflight community comfortable with small satellites deploying and operating from life-sustaining infrastructure. Having the ISS as a reliable deployment platform has allowed for tremendous growth of the CubeSat and small satellite industry.

By helping spacecraft navigate through the extremely complex ISS payload processing system over the last 5 years, we’ve determined the areas of major concern for satellite developers, some of which can end a mission. This paper outlines some of the issues we’ve identified. We aim to provide advice on how to mitigate concerns

and create successful missions through informed research, proper planning, and principles to follow.

This paper covers a select few areas that NanoRacks has seen as the largest obstacles for satellite developers. Each topic is not explored in great detail, so further research should be done based on the main points from each section.

**SATELLITE BUS & MISSION DESIGN**

In *Space Mission Analysis and Design*, Wertz and Larson recommend the first step of a satellite mission be defining the mission objective.<sup>1</sup> Understanding the scope is the first challenge a spacecraft developer faces; since the end goal will define the entire life of the project, it should not be taken lightly. For new payload and satellite developers, focus is the key to success.

***Payload Selection***

To design a successful mission, NanoRacks recommends selecting a single science objective (possibly two) and maintaining focus on that goal. If the payload will be developed in-house, the remaining subsystems should be outsourced, if possible.

The first consideration of payload design is the amount of volume available in the spacecraft structure. If the spacecraft is 1U in size, the payload cannot also be 1U. The rest of the critical subsystems (avionics board(s), power system, attitude determination and control system (ADCS), Radio Frequency (RF) system, etc) quickly add up and leave little room for a complicated payload. Therefore, the size of the satellite is a great place to start defining payload mission objectives.

If a 1U CubeSat feels too cramped, obviously a 2U or 3U size will offer more volume for the payload. However, the increased volume most certainly increases the spacecraft launch cost and sometimes complexity as well. Developing a payload from scratch is no small undertaking, and universities with small science departments or few Subject Matter Experts (SMEs) on

staff will find this especially challenging. The payload must fit mechanically, be integrated in the overall electrical system of the satellite, function properly, be able to adhere to the environment of the spacecraft's orbit, and be built to withstand a full range of testing. Planning an especially extravagant payload without dedicated expertise and resources can be a mission killer.

If the budget is small and the team inexperienced, NanoRacks recommends that developers focus on a smaller payload that still advances technology and has scientific value. Establish a clear goal that is within grasp, such as raising the technology readiness level (TRL) of an existing sensor or procuring the payload commercially. Plenty of valuable scientific data can be produced without reinventing the wheel. Just building a satellite, especially for a new developer, can still be extraordinarily educational and potentially useful for the scientific community.

### ***Bus Design***

NanoRacks classifies payload design separately from the satellite bus design. The implementation of satellite bus components should also go through the same review phase as the rest of the subsystems on the spacecraft. Satellite developers should also carefully consider whether the bus will be developed in-house or not.

The increased usage of the small spacecraft in recent years has generated a niche industry; satellite developers are able to procure commercially off-the-shelf (COTS) products from several vendors. For example, many developers are obtaining their power systems from commercial providers (ClydeSpace, GomSpace, ISIS, EnduroSat, etc.). Many of these systems have extensive flight heritage with numerous LEO missions, and are specifically designed to integrate easily with many types of CubeSat or small satellite buses. These providers have teams of experienced experts and are constantly innovating based on feedback from customer missions. NanoRacks has worked closely with several of these companies to ensure their systems comply with human-rated platforms. These products will often come tested and with all the appropriate documentation if requested.

In NanoRacks' experience, using a COTS system provides significant relief for satellite developers, especially newer teams with less technical capability. It allows developer teams to focus on the mission goal related to their payload and building an operational satellite. Generally, these systems are also more likely to fail than ones developed in-house. During functional testing, the COTS systems are easier to isolate, and should an issue arise, the providers have troubleshooting experience and failure analysis that can help identify root cause. In more extreme cases where

replacement is required, COTS parts can be re-ordered rather than redesigning the entire system in-house.

NanoRacks cautions new developers attempting to build an entire bus in-house. If that is the goal, then plan accordingly. Allocate resources to dedicated teams for the various subsystems and stay organized. It is difficult to develop core subsystems and payloads all within a reasonable timeline. Satellite missions have been delayed multiple years for this very reason. Luckily, through a deployment platform like the ISS, re-manifesting is more likely than a traditional expendable launch vehicle (ELV), for which the next available launch may be years away. That next launch might not even have the orbital parameters for which the spacecraft was originally designed, and mission requirements, including technical build and system architecture, can vary drastically.

At the risk of sounding like a broken record, we strongly suggest new satellite developers focus on designing first and foremost the payload, then perhaps one or two of the less complicated subsystems that lend to the expertise of the team (such as the mechanical structure). Otherwise, procurement of COTS components has become very affordable, especially when compared to the cost of the hundreds of hours spent on developing systems in-house. While COTS systems are still susceptible to anomalies like all spacecraft hardware, they are generally more reliable than in-house solutions and will meet most mission criteria for new spacecraft teams.

### **INHIBIT ARCHITECTURE**

An inhibit is defined as a single power interrupt that cuts off all power from the power system(s) on the spacecraft to the load (the rest of the operable systems).

Most launch vehicles require a single inhibit to prevent the spacecraft from powering on. This is largely to address inadvertent RF transmission when integrated onto the vehicle; the small satellite should not interfere with any launch site RF systems, but more importantly should not interfere with the RF systems of the primary payload. Should the spacecraft have more hazardous systems, such as propulsion or large pressure vessels, more inhibits or further verification of the functionality of the inhibit(s) may be required, but those requirements are ultimately at the launch provider's discretion.

For the ISS, inhibits are one of the main requirements that should be addressed at the beginning of the mission design. The number of inhibits required are based on hazard classification. NOTE: Remove or Apply Before Flight functions do **NOT** qualify as inhibits. Inhibits are to be numerated when the spacecraft is integrated with the separation system or the dispenser.

### ***Marginal or No Hazards***

A hazard is defined by the ISS safety standards as, “The presence of a potential risk situation caused by an unsafe act or condition.”<sup>2</sup> Systems with marginal or no hazards require a single inhibit, or sometimes no inhibits. This means that *should* the spacecraft turn on, there will be no issues with nearby systems. In the case of satellites awaiting deployment, the system should probably be off so as not to jeopardize mission success by losing power or overworking the payload. However, if deemed a marginal hazard or no hazard at all, the state of operation is irrelevant.

### ***Critical Hazards***

Systems with a critical hazard require two inhibits. A critical hazard is defined as:

*Any hazard which may cause a non-disabling injury, severe occupational illness, loss of emergency procedures, or involves major damage to one of the following: the launch or servicing vehicle, manned base, an on-orbit life-sustaining function, a ground facility or any critical support facility.*<sup>2</sup>

Two inhibits equates to “single fault tolerance”, meaning that should one of the inhibits fail, the other inhibit continues to prevent to system from activating.

An example of a critical hazard present on a small satellite on the ISS would be the presence of a transmitter that could potentially interfere with the communication link between the ISS and the ground. Similar hazards to human health may be associated with inadvertent transmission as well.

### ***Catastrophic Hazards***

Systems with catastrophic hazards require three inhibits, or dual fault tolerance. A catastrophic hazard is defined as, “Any hazard which causes loss of on-orbit life sustaining system function.”<sup>2</sup> Life sustaining systems include major components of the ISS infrastructure, such as the air filtration systems or the electrical backbone. These hazards are to include any danger to the crew, but also to all visiting vehicles. While some of these may seem like daunting requirements to implement, consider their justification. Payloads are constantly being ferried to and from the ISS, along with life sustaining equipment to keep up to six crew members on station alive and well. Should some of this be compromised by a small payload, it could result in serious consequences, and finding root cause can be difficult in a complicated integrated system like the ISS.

### ***Mechanical Implementation***

As defined above, an inhibit is meant to be a complete power interrupt that corresponds to a single mechanical switch. Generally, these switches are either the roller or the plunger types. Rollers, or auxiliary lateral inhibit (ALI) switches, are to be implemented on the rails of the satellite (should it be built for a canisterized dispenser). Plunger switches which are installed on the feet. Figure 1 shows two different implementations below.

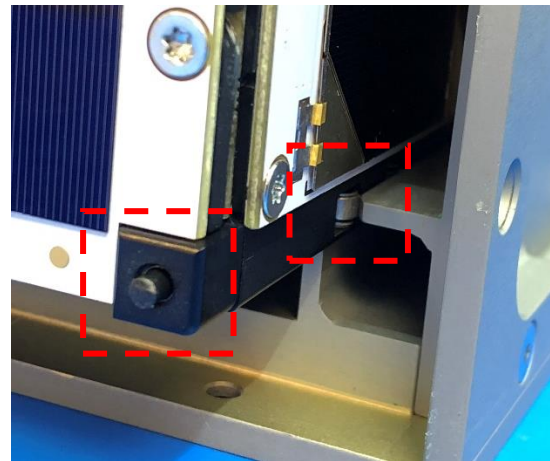

**Figure 1: Deployment Switch Configurations**

Some launch providers, including NanoRacks, may integrate multiple CubeSats into a single deployer to maximize volume and launch capacity. This has some considerations as to where to implement switches (we prefer rail implemented roller switches since the interface is better controlled), but either are acceptable and both have pros and cons.

### ***Electrical Implementation***

The electrical inhibit is supposed to cut off the entire load of the satellite bus from the internal power system(s) of the satellite. The switch can either be a FET on a board, or should that not be an option, the current can flow through an actual electromechanical switch. We advise caution if following the second option as the switches may not be rated to high currents and less reliable, but it is possible, and we have seen teams implement this.

Figure 2 is what we recommend for designing inhibit architecture.

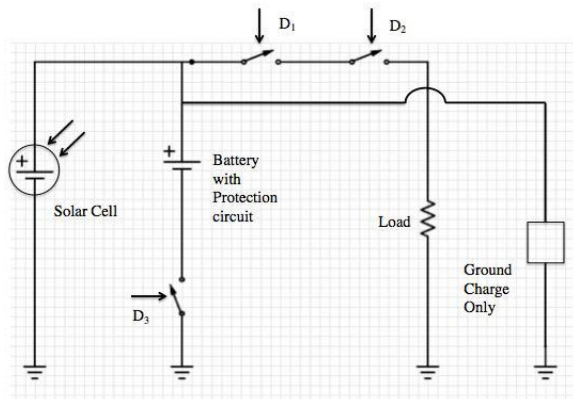

**Figure 2: Electrical Inhibit Diagram**

The inhibits lie between the power system and the load of the satellite. Any charging that could be provided by the solar cells are also inhibited. D1 and D2 are implemented in series on the high side of the battery. The third inhibit, D3, is implemented on the low side of the battery. The presence of this ‘ground leg inhibit’ is also a requirement for payloads flying to the ISS that rely on the electrical inhibits for hazard control. This protects against a single internal short across the battery which could provide direct connection to the ground.

On orbit, the spacecraft should not be charged until the spacecraft is released from the dispenser. Internal charging will be prevented due to the solar cells having no light exposure until the satellite is released into LEO, and the crew cannot charge the system externally prior to deployment in any of the current NanoRacks systems (this would technically be possible, however additional flight safety considerations would need to be accounted for).

Displaying the functionality of deployment switches is important for two reasons: mission success and verification. Of course, the switch must open and close the circuit. If it doesn’t function, then the satellite will not operate after deployment. These switches are inexpensive, especially when compared to the other costs of the mission, so NanoRacks recommends purchasing multiple of the same type, and doing some simple workmanship tests before integrating on the flight spacecraft. Many of these switches are rated for thousands of cycles, so don’t be too concerned about overuse.

One design complexity teams should consider to reduce risk to the mission is building redundancy into the inhibit system to eliminate the single-point failure point of each switch. Specifically, we have seen teams implement 3 sets of switches in series, each set wired in parallel for a total of 6 switches (while still maintaining 3 independent inhibits). While this adds complexity to the design, it can

seriously reduce the risk of a five-dollar switch ending a million dollar program.

Besides mission success, displaying switch and inhibit functionality during or after environmental testing may be required. While this may seem obvious, formalizing their operation may be needed to show proper hazard control. If the inhibits, and therefore switches, are controlling a major RF hazard (high power output or sensitive frequency ranges) then a control for that hazard is showing the system is not operating. When submitting ISS safety verification, a Certificate of Conformance (CoC) or Record of Assembly (ROA) concluding the system is unpowered when integrated into the dispenser will likely be needed.

We recommend baselining a three inhibit approach to any system. While none of the systems onboard may be considered hazardous, implementing dual fault tolerance is the best method to account for any safety issues that could arise during the flight safety approval process and can reduce major changes late in the project lifecycle.

Many COTS electronic power system (EPS) providers offer a “manned-rated” version of their power systems. These should include the proper inhibit architecture as well as proper circuit protection for the batteries (see EPS section). If designing the EPS is not in the scope of the mission, then we highly recommend purchasing one of these systems.

## UNIQUE SUBSYSTEMS

After determining the scope of the mission, one of the payloads on the spacecraft may end up being classified as a “unique” subsystem. Several types of unique subsystems are discussed below, but any component beyond typical subsystems (EPS, ADCS, etc.) can be considered “unique”. Based on the mission science objectives, these payloads can be complicated, such as a pressure vessels or propulsion systems. The following sections outline several unique systems that NanoRacks has encountered.

### *Pressure Vessels*

A pressure vessel is defined by NASA as a hermetically sealed system that is pressurized to 100psia or greater<sup>3</sup>. Hermetically sealed means that its internal pressure will not vary greatly (ignoring ideal gas law) when exposed to a vacuum; i.e. a mechanical forcing function is needed to cause any pressure changes. When flying a pressure vessel, several aspects should be considered, including design, manufacturing process, and acceptance testing.

The developer should first consider if the pressure vessel can be procured off the shelf. Because hardware is launched as pressurized cargo to the ISS, the spacecraft

will inevitably be traveling on United States highways and roads, meaning the vessel must be Department of Transportation (DOT) certified. If building the tank in-house, DOT requirements must be met.

Additionally, many systems procured off the shelf will have had leak testing, destructive testing, and assembly records. These processes save a lot of work for developers with limited budgets and resources. This paperwork will have to be produced as verification for flight safety compliance, therefore it's good to have on hand. It also avoids developing unique test plans for the pressure vessel, further reducing the mission test regime.

NanoRacks has recently seen many payload developers looking to utilize new types of pressure vessels with unique materials or cutting-edge manufacturing methods (such as additive manufacturing). While these are interesting technology developments, teams need to ensure not to underestimate the analysis and test requirements that will be levied to be compliant with DOT and NASA flight safety requirements. These will include testing such as destructive burst tests and a lot of additional paperwork such as manufacturing records, material certifications, etc. While not impossible, this needs to be budgeted for in advance if looking to qualify a system such as this for manned flight.

### ***Propulsion***

Propulsion is a sensitive topic for payloads flying to a manned station. Propulsion can pose a legitimate threat to the crew, life sustaining equipment, visiting vehicles, and other critical space assets, and therefore is extremely scrutinized. It can be difficult to get full approval of a propulsion system, and in many cases, fundamental changes will be levied to become more compliant with manned spaceflight requirements. The review process will be extensive and often requires several meetings to explore failure scenarios and outlying cases. The developer should be prepared to produce analyses, write reports, have organized paperwork, and be willing to make design changes.

The work required for a propulsion system can be intimidating, and some developers simply do not have the ability to support a propulsion system through the safety approval process. That's okay; if it's an experimental system with little or no flight heritage, flying on manned spaceflight missions is probably not the right choice anyway, and an ELV opportunity should be explored instead. Even if it is a system with heritage, it still may not be a good match. If the goal is to achieve orbit or plane changes, then high delta-v systems are probably non-starters, or systems with highly toxic propellants (hydrazine) are likely not going to be compliant when used on a small spacecraft that comes

near astronauts. However, the opportunities for safety approval are much higher for systems simply used for attitude control or station keeping.

Two major areas must be considered if the satellite is flying as pressurized cargo: traversing through the inhabited volume of the station, and post deployment operations in LEO.

When traversing through the internal volume of the ISS, the system will need to remain inhibited. The three mechanical/electrical inhibit approach will work when the satellite is still in the dispenser or attached to the separation ring for any electric propulsion system. The propellant must also be considered. Toxic substances must have proper levels of containment and redundancy in the seals / valves. Given the high delta-v nature of a monopropellant system, it's unlikely it would be approved by the safety process for most small satellites, but if it were, a highly toxic chemical such as hydrogen peroxide would need multiple levels of containment, and therefore would be very difficult to control. In the case of a lower delta-v system, non-combustibles may be acceptable. In our experience, even if the propellant is not a toxic material or is properly contained, the environmental filters on the ISS may not be able to accommodate certain types; therefore, before selecting a propulsion system, material compatibility should be considered.

As mentioned earlier, post-deployment considerations also come into play. All items jettisoned from the ISS must be analyzed for potential recontact. Ultimately, the maximum delta-v of the system in a single worst-case failure should be investigated. This analysis explores how much delta-v can be expelled when the system fails and stays in the "on" position. Some questions that the safety process often asks are: Can the system expel all its delta-v at once? What are the physical limits of the system (power budget, software timer, thermal conditions)? These questions will need to be answered during safety review meetings, and in some cases, analyses will need to be produced to verify those answers.

It should be noted that truly redundant post-deployment inhibits are challenging to implement for most small satellite teams due to the strict requirements of the ISS Program with respect to electrical requirements and Computer Based Control Systems (CBCS) standards. Effectively, it is near impossible to convince the ISS Program that any inhibits are redundant on an operational system unless they are completely isolated and controlled by independent processors. While there is a way to meet all post-deployment requirements and design a high dv propulsion system capable of

completing proximity operations with the ISS, NanoRacks has yet to work with a small satellite team willing to invest the time and resources required to do so. Therefore, the small satellite systems that have flown to ISS to date were approved based on limited capabilities that resulted in an extremely low risk of recontact to ISS.

Each propulsion system is looked at on a case by case basis, so NanoRacks recommends working closely with the mission management staff early in the development stage. Avionics and system architecture are also critical for compliance but are not covered in this paper.

**High Power Transmitters**

Experimental communications payloads are becoming more common on small spacecraft. Generally, the bus size offers enough room to work with capable communications systems in LEO, and these systems are often less expensive to build. From a safety standpoint, a potential Radio Frequency (RF) hazard is one of the main considerations for every spacecraft. RF hazards can be separated into two parts: potential human health dangers for the crew and interference with critical station assets.

Fortunately, brief calculations can determine the potential for RF hazards; this assessment relies on the center frequency, antenna gain, and maximum power output of the transmitter. NanoRacks recommends working with the mission management staff early in the payload design phase to address these concerns.

**Deployable Appendages**

A deployable component is defined as anything that can be released to extend beyond the nominal envelope of the spacecraft. A common example of deployable appendages are solar arrays, which can be seen in Figure 3. Deployables are perfectly acceptable to use, but some considerations should be made.

One of NanoRacks’ main concerns with deployables is to show that any potential “hang fire” is not credible. A hang fire occurs when the deployable appendage catches on part of the dispenser and the satellite does not completely deploy. These situations are important to address, because a hang fire is an indeterminate system. On an ELV, hang fires might not be as important. The primary payload has either already deployed, or the secondaries are integrated in a way that is relatively independent of the primary. On a manned platform, however, a potential collision scenario with visiting vehicles, robotic and EVA activity, or other types of hosted payloads and life sustaining equipment is a catastrophic hazard and is simply unacceptable. Dispensers are generally designed to prevent hang fires by utilizing smoothbore walls and step-down interfaces,

but these aspects do not totally mitigate the potential for a hang fire.

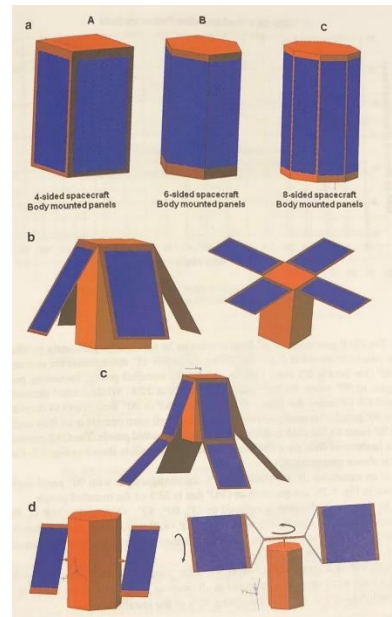

**Figure 3: Example Body-mounted Arrays<sup>12</sup>**

In order to fully disprove the possibility of a hang fire, NanoRacks recommends and often times requires a pull-through test with our deployer and an engineering model of the satellite. It is a simple test which can be performed at various stages throughout the integration or testing phases. In our experience, pull-through testing provides great risk mitigation and can reduce scrutiny of retention mechanisms. NanoRacks recommends redundant systems to prevent inadvertent release; however, we understand the potential threat to mission success by having more than one burn wire or physical switch. Therefore, analysis or physical tests are the best way to show deployables are not a cause for concern.

**Lasers**

Lasers offer a wide range of uses on a small spacecraft. In particular, NanoRacks is seeing more and more small satellites looking to demonstrate optical communications and other interesting capabilities like laser range finding.

If the laser is inhibited when close to crew members on the ISS, there isn’t much cause for concern. Table 1 shows most of the information that should be provided when flying to a manned platform.

**Table 1: Example Laser Specifications**

System Property	Example Response
Type of laser	Er doped silica fiber

Class of laser	Class IV
Lasing material	Er
CW or pulsed	pulsed
Wavelength	487 nanometers
Bandwidth	50 MHz to 1 GHz
Energy per pulse	.7 uJ/pulse at 50 MHz
Pulse duration	250 nanosecond at 50 MHz
Pulse rate	50 MHz to 200 MHz
Max duty cycle	50%
Avg Power output @ duty rate	10W
Beam divergence at 1/e point	12 milliradians
Emergent beam diameter	0.1 mm
Voltage of system	8.4 V
Electrical power consumed	20W

The above information can be used to classify the laser and determine the Nominal Ocular Hazard Distance (NOHD). This defines the hazard classification and the associated required inhibits while in proximity of the ISS.

Coordination to operate the laser should be done with the DoD Laser Clearinghouse to ensure legal and safe operation. The Federal Aviation Administration (FAA) also has applicable commercial standards. Operating within a certain vicinity of other vehicles in orbit should be defined and avoided when necessary. Remember, being a good steward of space is important for achieving long term goals.

## POWER SYSTEMS

One of the most critical subsystems in any spacecraft is the Electronic Power System (EPS), as this drives the functionality of the payload and all other major subsystems. While the most obvious design driver for the power system is performance and capacity relative to the predicted power budget, there are several other critical factors to consider when flying to a manned platform such as the ISS. This section will focus primarily on design considerations, test requirements, and lessons learned from qualifying small satellite scaled power systems for flight to the ISS.

### *COTS vs. Custom EPS*

As discussed earlier, one of the first things to consider when designing a spacecraft is determining what subsystems will be procured commercially off the shelf (COTS) and what will be developed in-house; this is no different for the EPS. There are a wide variety of commercial vendors that provide power systems for small satellites, ranging in price, performance, and compliance with manned spacecraft requirements. There are numerous drivers that influence the decision of whether to procure a COTS power system vs. develop an in-house solution, including budget, schedule, reliability, performance, and of course compliance with flight safety requirements of the launch vehicle (LV). So long as there is a system on the market that meets the technical requirements of the satellite in design and the budget can support the procurement of a COTS system, it is almost certainly going to present less technical and schedule risk to simply buy a power system than try to develop one in-house. This is particularly true for first-time satellite developers with less experience than more experienced teams with heritage components on other spacecraft.

### *Vendor Selection for COTS Components*

The small satellite vendor market has grown dramatically in recent years, giving the consumer a wide variety of options when shopping for subsystems such as an EPS. As the number of providers has increased, it's critical to carefully consider the different COTS options. While some subsystems may have impressive performance characteristics, it's important to weigh other factors such as flight heritage when selecting a system. One selection criteria that can't be ignored is compliance with flight safety requirements. There are a wide number of power systems on the market that may claim to be compliant with manned spaceflight platforms. Prior to making the purchase, work with the launch provider to ensure that is the case. NanoRacks has spent a significant amount of effort working with commercial EPS providers to ensure their systems adhere to manned spaceflight design & test requirements and can help educate teams during the selection process.

### *Cell Selection Criteria*

If developing an EPS in-house, perhaps the first design consideration is the type of cell. Nearly all small satellites are now utilizing Lithium-ion or Lithium-ion polymer cells due to their excellent technical specifications such as high energy density, efficiency, and long lifetime.<sup>6</sup> The nominal voltage of Li-ion cells is approximately 3.6V but the capacity of the cells can vary depending on the size / form-factor and cell chemistry.<sup>3</sup> Apart from the performance characteristics and capacity, there are other critical design factors to consider when

selecting cells related to manned spacecraft flight safety requirements.

The first major item to consider is the cell chemistry and toxicity of the liquid electrolyte. For example, cells with an electrolyte toxicity hazard level (THL) 4 should not be used in a habitable space environment per current ISS requirements.<sup>3</sup> Examples of such cell chemistries include lithium-sulfur dioxide, lithium-sulfuryl chloride, lithium-thionyl chloride, and Li-BCX.<sup>3</sup> Carefully review the toxicity of the cells to ensure compliance to a manned platform as these toxic cell chemistries are common in other industries.

For example, NanoRacks has had to require a team utilizing a small coin cell with lithium-thionyl chloride chemistry to swap out their cell for a less toxic alternative. Fortunately, there are many Li-ion cell chemistries on the market that are less hazardous (typically THL-2) that are acceptable in space applications for flight on manned platforms. Examples of acceptable cell chemistries include lithium manganese dioxide and lithium iron phosphate (among others).<sup>3</sup>

Another factor to consider with respect to flight safety requirements when selecting a cell type is protection circuitry. Any cell in a power system that flies to a manned platform requires some form of circuitry to protect against potential strain that could cause a hazardous event. The three major types of protection circuitry required for Li-ion and Li-ion polymer cells used in small satellite applications on the ISS are outlined below:<sup>3</sup>

- Over-charge protection circuitry
- Over-discharge protection circuitry
- External short protection circuitry

The required protection circuitry can technically be implemented either at the cell level or at the battery pack level. Regardless of the implementation approach, it is critical when choosing the cell to understand the protection circuitry that is inherent at the cell level. In many cases, this will drive the flight certification test protocol and protection circuitry design of the EPS, so it cannot be overlooked.

### ***Cell / Battery Test Requirements***

NanoRacks has spent a significant amount of effort working with the Johnson Space Center (JSC) Propulsion and Power Division to refine the battery test requirements for Li-ion and Li-ion polymer cells used in small satellite applications on the ISS. When NanoRacks began facilitating launch of small satellites to the ISS in 2013, the test requirements for Li-ion cells were

extremely intensive and it was not practical for most CubeSat teams to complete. While refining the test requirements is still a work in progress, NanoRacks has developed a statement of work based on the available JSC documents and several working groups with the JSC Battery Group that is much more reasonable for payload developers across all levels of expertise to complete.

Although the test requirements are well defined, there are still many lessons learned from previous test campaigns that can be passed along to future small satellite teams. First, there is a common misconception of what the intent of the battery testing is. Often teams view these as environmental tests, when in fact the suite of testing is really designed as workmanship tests to verify designed protection schemes and screen the cells / batteries for manufacturer defects that could lead to a hazardous event (such as electrolyte leakage or thermal runaway).<sup>3</sup> For example, the flight acceptance vibration test may not necessarily serve as the battery vibration test.

The Li-ion and Li-ion polymer cell / battery test requirements consists of the following major tests / procedures:<sup>7</sup>

- Measurement of Physical Properties
- Baseline of Electrochemical Characteristics
- Charge Cycling
- Over-Charge Test
- Over-Discharge Test
- External Short Test
- Vibration Test
- Vacuum Test
- Thermal Runaway Propagation Test (if required)

The majority of lessons learned associated with the required testing is due to a lack of understanding of what tests can be done at the cell vs. battery pack level, and what testing can be done as qualification testing vs. acceptance testing. Technically all these tests could be conducted at the cell level if the appropriate protection circuitry is in place. However, cell-level protection circuitry is often non-resettable or subject to failure beyond the first instance of operation, resulting in most teams implementing some form of battery-pack level protection.

For the over-charge, over-discharge, and external short testing, NanoRacks recommends testing the protection circuitry that will be in place on the flight system (whether that be at the cell or the pack level). Should the protection circuitry that will be relied upon during flight be at the cell level, a qualification test approach is most appropriate (where the tested cells are certified from the



same lot as the flight cells that are not subjected to the protection circuitry tests).

While some tests may be conducted on flight equivalent cells from the same lot, note that lot traceability can be difficult to verify especially when procuring cells from an online vendor or reseller. It is recommended that cells be procured directly from the manufacturer when possible, otherwise a qualification test approach may not be possible due to the fact lot traceability cannot be verified.

Besides the protection circuitry tests, the majority of the testing must be conducted on the flight cells (such as the charge cycling, vibe, and vacuum for example). This testing can be performed at the cell or the battery level, except for one of the electrochemical characterizations: the 14 Day Open Circuit Voltage (OCV) test. This test requires the OCV to be monitored incrementally throughout a 14-day period to detect for declining voltage in the cell.<sup>7</sup> One of the lessons learned from previous testing is that this test cannot be performed at the pack level. Even if the pass-fail criterion of declining voltage is scaled based on the quantity of cells, there is no way to isolate a failure in any one cell in the pack. Therefore, this test should be performed on all cells prior to pack assembly should the remainder of the testing be performed at the pack level.

As with any flight safety testing, NanoRacks recommends the launch service provider review all test plans prior to starting testing to avoid any unnecessary mistakes during test that may cause delays in schedule and increased cost.

### ***Thermal Runaway Propagation***

One of the flight safety considerations for Li-ion and Li-ion polymer cells is the risk of thermal runaway propagation. Thermal runaway is defined by JSC as,

*a condition whereby a cell or battery overheats and reaches very high temperatures in very short periods (i.e., seconds) through internal heat generation caused by an internal short or due to an abusive condition.*<sup>3</sup>

While the risk of a spontaneous internal short can never be completely eliminated in a single cell, so long as the toxicity of the vented gasses is below a given threshold and the flammability of the surrounding materials is limited, the safety hazard can be controlled. The major concern for manned space platforms with respect to thermal runaway is cell-to-cell propagation should a single cell enter a runaway event. The ISS Program has selected a total battery energy of 80Wh as a strict threshold at which thermal runaway propagation testing is required.<sup>3</sup> To date, the vast majority of CubeSat power

systems that NanoRacks has processed have been below the 80Wh threshold.

Despite the fact thermal runaway propagation tests are not always required, NanoRacks does have extensive experience in the qualification process for Li-ion battery packs greater than 80Wh.

The largest battery NanoRacks has supported through the qualification process for flight to the ISS to date is approximately 480Wh. For systems with this much energy, there is no way to avoid having to complete multiple destructive thermal runaway tests to show that the battery pack is designed to effectively prohibit cell-to-cell propagation. Unfortunately, there is no generic approved thermal runaway test plan, so the exact test protocol is still handled on a case-by-case basis with the JSC Battery Group when qualifying systems for flight to the ISS.

Even though there is no approved test plan for thermal runaway testing, there are still several design considerations and lessons learned with respect to designing compliant systems with manned spacecraft requirements. For example, understanding the cell vent path is critical when designing the battery enclosure to ensure that if a single cell enters thermal runaway, it will not immediately trigger adjacent cells. Depending on the cell design, it may be necessary to add additional structure and heat sinks around each cell to mitigate against cell-to-cell propagation. This is critical to consider when budgeting the total spacecraft mass and the volume of the EPS.

If mass is a major design driver, it's possible thermal runaway mitigation may end up being a critical design driver in the power system with respect to cell selection. For example, 18650 cylindrical Li-ion cells have a much more predictable vent path than Li-ion pouch cells, which may be beneficial when designing a system that prohibits cell-to-cell propagation.

NanoRacks has additional lessons learned when qualifying power systems above 80Wh, based specifically on the current battery test requirements of the ISS Program. While not all of these can be detailed in this paper, one recommendation based on experience when designing power systems above 80Wh is to keep individual battery packs below the 80Wh threshold and otherwise electrically and physically isolate these packs within the spacecraft bus. Of course, in CubeSats and other small satellite platforms, physically isolating battery packs can be challenging but it may be necessary in order to avoid extensive thermal runaway testing. Any destructive testing with a challenging pass / fail criterion such as cell-to-cell propagation adds cost, schedule, and

risk to any spacecraft qualification program and should be avoided if possible.

Ultimately, there are many design considerations and significant testing that go into developing and qualifying an electronic power system that is compliant with manned spaceflight requirements. This inevitably introduces additional schedule and cost that must be budgeted for when planning to develop and qualify a spacecraft for flight to a platform such as the ISS. To mitigate this impact, it is recommended that less experienced developers procure a COTS EPS with flight heritage on manned platforms. Regardless of whether the power system is procured commercially or developed in house, it is good practice for teams to engage early and often with their launch service provider such as NanoRacks to ensure that the design and test plan is compliant with all requirements and safe for flight.

## **MATERIALS SELECTION & USAGE**

Due to recent increases in commercial spacecraft component providers, small satellite developers are now able to focus on mission design by purchasing COTS hardware. While these systems are selected for their application to the satellite's goals, they are sometimes made of materials that do not respond well to the space environment. To reduce significant re-work for materials noncompliance, NanoRacks recommends adhering to the guidance outlined in this section.

### ***Outgassing and Contamination***

One of the main materials selection concerns for most spacecraft is outgassing, which is the release of gases and particulates when the satellite is exposed to a vacuum environment. These released gasses have the potential to contact other satellites and re-condense on critical systems. For example, an epoxy might outgas onto another spacecraft's optical components, potentially obscuring valuable data.<sup>4</sup> Since the ISS must be able to support human life at all times, outgassing prevention is especially important for satellites deployed by NanoRacks.

Typically, if a high-outgassing material must be used for satellite components, a thermal vacuum bake-out test is required prior to flight. In lieu of this test, an audit of the materials used on the spacecraft is performed to find bad actors, and in some cases, a formal analysis is performed to assess contamination levels. This analysis requires a list of all non-metallic materials utilized in the spacecraft and the corresponding surface areas of those materials. The baseline requirements for the materials list are based on two outgassing properties: Total Mass Loss (TML) and Collected Volatile Condensable Material (CVCM). The general NASA standard is to require a TML of  $\leq 1\%$

and CVCM of  $\leq 0.1\%$ . Note, this is not necessarily a requirement by ISS Program and all materials being exposed to the external environment are subjected to review.

Once the satellite developer has determined an initial components list, NanoRacks recommends referencing the TML and CVCM data of all materials on [outgassing.nasa.gov](http://outgassing.nasa.gov). If the material is below the required levels, in general it will be acceptable especially in satellites that will not spend much time outside the ISS prior to deployment; if the TML or CVCM values are only slightly exceeding, contact NanoRacks for additional evaluation. TML/CVCM levels much higher than the requirements should be carefully considered before use, due to the potential for rejection by the ISS Space Environments Group.

The NASA outgassing database is extensive and should provide developers a baseline for materials selection; however, NanoRacks' several years of experience have revealed certain materials to carefully consider before use. One of these materials is polyvinyl chloride (PVC). PVC is sometimes used in COTS ribbon cables or connectors, but typically has very high TML and CVCM levels. If a developer *must* use PVC in a satellite deployed from the ISS, NanoRacks advises that the PVC components might be rejected or require additional containment (hermetically sealed or covered with a conformal coat or Kapton tape).

### ***Toxic Material Containment***

Since the ISS is a human-occupied platform, numerous precautions are taken to ensure the safety and well-being of the inhabitants. These precautions include preventing any toxic material from interacting with the astronauts. The NASA document "Guidelines for Assessing the Toxic Hazard of Spacecraft Chemicals and Test Materials" characterizes the Toxicological Hazard Levels (THL) associated with certain materials.<sup>8</sup>

Table 1 on page 3 of the above document describes the hazards associated with each toxicity level. These hazard levels correspond to the degrees of containment required while the material is inside the ISS. For example, a THL-1 material must have two separate methods of containment. These containment levels could be achieved by hermetically sealing the material in a container, then surrounding the container with a payload enclosure. Materials such as refrigerants and thruster propellants often receive high scrutiny from the ISS Safety Review Panel; implementing proper containment levels typically alleviates any concerns. NanoRacks safety engineers have collaborated with several satellite developers to successfully design a containment system that adheres to ISS Program requirements.

### ***Re-entry Survivability***

The average small satellite in low Earth orbit has a relatively short orbital lifetime due to its low mass relative to projected surface area. This diminutive size also results in the entirety of the spacecraft burning up as it re-enters Earth's atmosphere. However, any small satellite with a mass greater than 5 kg is required by the ISS Program to submit an Orbital Debris Assessment Report (ODAR) to the ISS Program Trajectory Operations Office (TOPO) for jettison assessment. This assessment identifies any spacecraft components likely to survive re-entry and implements a probabilistic model to determine the potential for human casualty on the ground.

While the ODAR and many of the other materials selection criteria are levied by NASA requirements, the FCC also analyzes spacecraft materials re-entering the Earth's atmosphere for domestic spacecraft requiring FCC licenses. The FCC relies on a standardized limit for all orbital re-entries: components returning to Earth should impart less than 15 Joules of energy to any point of impact on the ground. In NanoRacks' experience, materials with high melting points, like titanium, often get approved through the NASA debris analysis, but cannot gain FCC permission due to re-entry energies greater than 15 Joules. To mitigate debris analysis concerns, coordinate with NanoRacks early in the design process if any high melting point materials are being considered.

### ***Off-gassing Considerations***

The vacuum environment of space causes outgassing in certain materials (as outlined above), but some materials also off-gas in a pressurized environment. Off-gassing is often described as "the new car smell" and is the result of materials releasing chemicals in an enclosed area. The ISS is especially susceptible to off-gassing, since the released materials cannot easily be vented out of the station. If the payload developer plans to use high off-gassing materials, testing according to NASA-STD-6001A might be required.

### ***Spacecraft Materials Testing***

If materials are not contained in a NASA database or have the potential to violate ISS Program requirements, additional testing is sometimes necessary. These tests include American Society for Testing and Materials (ASTM) E595 and E1559.

#### ***ASTM E595***

ASTM E595 testing determines a material's TML and CVCM, so it typically is only necessary when a material is not contained in the NASA outgassing database. To determine how the material will react in a vacuum

environment, a test specimen is placed in a thermal vacuum chamber for 24 hours. The material is heated to 125° C and allowed to condense on a collector at 25° C.<sup>9</sup>

#### ***ASTM E1559***

While E595 measures the amount of mass that outgasses in a vacuum environment, ASTM E1559 tests the kinetic interactions of particles discharged from a spacecraft.<sup>10</sup> If a material cannot be found in the NASA outgassing database and the results of ASTM E595 are inconclusive, ASTM E1559 must be conducted before the material can be approved.

### **ENVIRONMENTAL & VIBRATION TESTING**

Environmental testing is one of the major phases of spacecraft development and can occupy a significant part of the ground phase of the satellite's life. The importance of environmental testing should not be understated, as it is a true indicator if a spacecraft is prepared for launch and on-orbit operations. Extensive test plans should be developed early in the mission lifecycle and revised as the project grows. Testing should be a combination of mission success criteria and launch provider requirements.

Launch Vehicle (LV) test requirements should be considered non-negotiable. Unless there is a waiver process outlined, write LV requirements into the test plan and prepare to follow through. The principle "test like you fly" should be adhered to as closely as possible; when deviation is necessary, the testing sub-team should substantiate the difference with technical rationale.

In addition to LV requirements, there are qualification and flight acceptance tests. As discussed in the Power Systems section of this paper, qualification means the tests can be done on a non-flight but flight-identical article. For example, if shock testing is a qualification test but not flight acceptance, then the designated shock procedure can be performed on the engineering model of the spacecraft, if available. Flight acceptance means it *must* be performed on the flight article. Usually flight acceptance tests occur near the end of the entire test regime, because there should be little to no configuration changes afterward.

NanoRacks has worked hard to outline requirements that cover all potential ISS resupply missions and have made testing as minimal as possible for payload developers. Should a mission to a manned platform slip, then re-manifesting on a similar vehicle is possible with little to no changes (common launch requirements).

It should be noted that there is a tremendous amount of other spacecraft testing not discussed in this section or this paper. NanoRacks recommends engaging with the

small satellite community and reading NASA GEVS thoroughly to properly test a small spacecraft. It is understood that many teams do not have the budget for an engineering model, so additional margin should be built into the design if completing a protoflight test campaign as there is no room for error. This is not recommended if it can be avoided.

**Random Vibration**

One major requirement across all launch vehicles, including to the ISS, is random vibration testing. It generally consists of a 60 second vibration test in all three axes for flight acceptance. Sine sweeps, performed before and after test runs to identify the fundamental modes of the spacecraft, are optional to perform, but highly recommended as this can identify major structural issues that may not be noticed during visual inspections. Random vibration is generally performed as a hard-mount test; when flying as internal cargo, there is the option to “test like you fly”, which involves layering the spacecraft in bubble wrap and foam during the vibration test to simulate the launch environment.

This test should be worked closely with the launch provider, but it usually provides significantly less strain on the vehicle. Table 2 shows hard-mount and soft-stow profiles compared to one another. Soft-stow absorbs a lot of the energy and can be beneficial to sensitive payloads like imagers. The third test in Table 2 is the NASA GEVS workmanship vibration profile.<sup>11</sup> The workmanship vibration is meant to identify workmanship flaws, like an un-torqued or un-staked fastener, or issues with structure.

**Table 2: Vibration Level Comparisons**

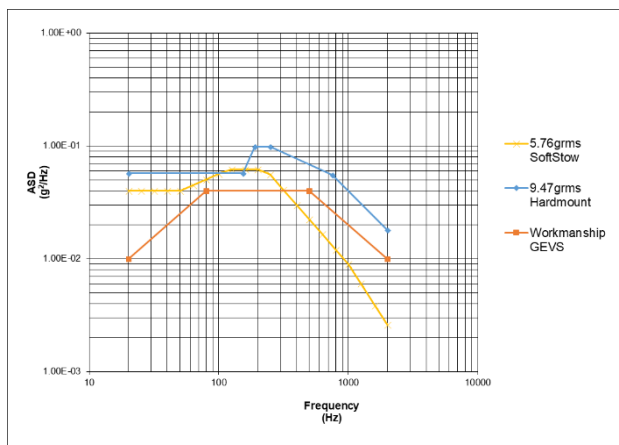

It is highly recommended to perform a workmanship test due to its targeted nature; however, it is not a requirement for satellites launched as ISS cargo inside of the NanoRacks CubeSat deployer so long as other measures are taken to verify hardware configuration post-test.

**EMI/EMC Testing**

EMI/EMC testing is generally not a requirement for flying small satellites as pressurized cargo to the ISS. The payloads are quiescent during launch and stowage until deployment, and the standard spacecraft 30-minute post-deployment timer is a good catch-all for RF interference. Should the payload need to operate immediately after deployment, potential radiated or conducted emissions testing can be performed; however, this is usually determined on a case by case basis.

**Thermal Vacuum Testing**

Thermal Vacuum (TVAC) testing is a critical part of the ground segment for a spacecraft. It is the closest representation to the environment the satellite will operate in and pushes the satellite’s subsystems to their limits. TVAC is not usually a mission requirement (in special cases of materials usage it might be), but TVAC should not be overlooked. TVAC testing is crucial to verifying the spacecraft performs as expected, but it should also not be scheduled at the end of the testing regime.

In NanoRacks’ experience, developers generally plan this test last and too close to hardware delivery; TVAC often discovers several problems that can require entire subsystem redesign. Developers should perform TVAC tests on subsystems individually when possible and plan appropriate schedule for troubleshooting problems when they inevitably surface.

At some point, it may be necessary to weigh mission success versus hardware delivery. Re-manifesting may not always be an option for satellite developers, especially when manifested on a more traditional ELV; therefore, hardware delivery deadlines should be prioritized. Ensure the flight acceptance tests levied by the launch provider have been completed, then perform a basic risk assessment for delivering a potentially “undertested” spacecraft. Most satellite developers will say that a spacecraft could always use more testing, but at some point, it needs to leave the laboratory. Especially for newer teams, even if the spacecraft does not work perfectly on-orbit, there is a tremendous amount to learn from building a spacecraft and getting it to orbit.

**REGULATORY LICENSING**

While regulatory licensing can be difficult to navigate for small satellite developers, it is arguably one of the most important requirements to satisfy and is a mission killer without. What licenses does your spacecraft need? When should the process begin? For some small satellites, regulatory licensing can become neglected, coming down to the wire for when it’s needed, and result in de-manifestation of your spacecraft. This risk,

however, can be properly mitigated through pro-activity and proper guidance.

### ***NOAA Licensing***

Any private space-based remote sensing system (i.e. scanning the Earth to obtain data, taking photographs/videos, etc.) requires licensing. The responsibility to issue these licenses has been delegated by the Secretary of Commerce to the National Oceanic and Atmospheric Administration (NOAA). To determine if your satellite needs a NOAA license, you should fill out NOAA's "initial contact form", which consists of a brief description of the mission objectives and operations. The form is a simple Google doc questionnaire that takes roughly 10 minutes to fill out (<https://www.nesdis.noaa.gov/CRSRA/generalApplication.html>). After filling out this form, NOAA will either provide a memo indicating that no license is needed, or seek more information about your system before providing a license. This is an important pre-requisite to receiving an FCC license, as the FCC will usually ask for evidence of coordination with NOAA to be submitted as an exhibit.

### ***FCC Licensing***

There are three FCC licensing paths that we commonly see for domestic non-government spacecraft: Part 5 Experimental, Part 25 Commercial, or Part 97 Amateur. With any path, it is generally recommended that licensing is filed within 30 days of launch vehicle selection/manifesting, and around 9 months to a year prior to final delivery. Small satellites with unique radio ConOps, or operation in governmental bands that will require additional coordination efforts, should allow more time for regulatory approval. Below are things we've seen with each of the FCC licensing paths:

#### ***Experimental***

An experimental radio service, per 47 CFR Ch. 1, is "a service in which radio waves are employed for the purposes of experimentation". We see many teams use this licensing approach, as many small satellites seek to demonstrate technology or perform some type of experiment. If the operational lifetime of the satellite is less than 6 months, payload developers can pursue a Special Temporary Authorization (STA). Developers with a longer duration of experimentation should file for a regular experimental license using FCC form 442. Many of our developers seek the regular experimental license, as they are on-orbit for at least 1-2 years.

#### ***Amateur***

An amateur service, defined by the FCC, is "a radio-communication service for the purpose of self-training,

intercommunication and technical investigations carried about by amateurs...without pecuniary interest". Deciphered, this means that an amateur operator shouldn't have a financial interest in the system. What we've seen recently, however, is that developers seeking amateur licenses need to be purely amateur; meaning no government, university, or other stakeholders (including commercial) should be invested in the project.

As of recent, there has been plenty of confusion in the small satellite community about how to navigate between amateur and experimental licensing. In the past, payload developers have utilized the International Amateur Radio Union (IARU) to coordinate frequencies for their spacecraft. However, the IARU seems to have stopped coordinating amateur frequencies for those seeking experimental licenses with the FCC, meaning payload developers are having to coordinate frequencies for themselves. This coordination can prove to be daunting, as the available frequency bands for space-to-earth transceiving are limited and can be quite congested. In fact, sometimes teams are asked to produce electromagnetic compatibility analyses to determine what interference their system might have with other active satellites. As processes have changed, many small satellite developers have started to seek guidance from consultants, or other satellite developers who have navigated these waters in the past.

#### ***Commercial***

Few small satellite systems have used this licensing path in the past, however, as technology is refined and new business plans arise, this approach has become more common. We typically see this path as almost exclusively used by commercial companies that seek to generate revenue with their satellite(s).

#### ***Special Licensing Conditions***

It is important to be aware of the special conditions stated on your FCC license. Common conditions that we've noticed within FCC licenses include being proactive about collision risk mitigation, operating on a non-interference basis, and notifying regulatory bodies when the satellite transmissions commence and terminate.

Note: To help understand and mitigate collision risks, get in touch with the 18<sup>th</sup> Space Control Squadron (previously known as JSpOC) a couple months prior to launch. They will set you up with a Space-Track account to retrieve orbital data and conjunction assessments.

#### ***Manned Station Requirements***

One nuance that comes into play when adhering to manned spaceflight requirements, is determining how

your small satellite's RF operations might interfere with the ISS. After collecting the technical specifications of your radio(s), the Johnson Space Center Spectrum Office performs a radio frequency compatibility analysis to determine if there is any interference with critical ISS or visiting vehicle communications, and if any is found, what operational constraints are to be placed on the spacecraft. While many small satellites do not experience constraints in operation, there have been some unique cases. As an example, a recently launched small satellite causes interference to the ISS video communication systems used during Extra-Vehicular Activities (EVAs). Due to the potential severity of this, the ground station uplink is constrained during EVAs. The best advice to avoid these types of constraints is to be pro-active about submitting radio specifications (preferably around L-6) early in the launch mission phase to identify potential issues.

## CONCLUSION

Developing, launching, and operating a spacecraft is no small feat. It is a complicated undertaking that simply takes time, effort, resources, and patience. The goal of this paper is to provide lessons learned from a launch provider perspective on how to interpret and adhere to the requirements of manned spaceflight and to understand the implications of taking on various satellite design facets versus procuring from another source.

This paper does not cover other extensive topics that should be reviewed, such as overall spacecraft design, systems engineering principles, and effective project management. NanoRacks recommends extensive research and education in these fields. An informed program is one that makes delivery on schedule and often sees the highest degree of mission success. An informed team also understands expectations of designing, building, launching, and operating a small satellite.

The small satellite and aerospace community has produced copious amounts of open source documentation for nearly every part of launching a payload into orbit. Along with learning from standard classes and schooling, engage with developers that have sent small satellites to space in the past. Consult industry standard texts such as *Space Mission Analysis and Design (SMAD)* or NASA GEVS. These works were used as references in this paper and any expert in the field can attest to their usefulness. Experience is key in deciphering the countless nuances of spaceflight.

The small satellite has proven itself to be just as competitive, effective, and legitimate as its larger brethren that occupy LEO and the rest of the sky beyond the von Karman line. Perhaps its most important facet, though, and the CubeSat's original intent, is to provide

affordable educational opportunities for new engineers and researchers to get hands-on-experience designing real spaceflight missions, building real flight hardware, and operating a real spacecraft in space. For new spacecraft programs, this should be the goal. Define mission success at the beginning of the project, and continually look back to the criteria set forth as a reminder to what the final product of the entire mission looks like.

## References

1. J. R. Wertz and W. J. Larson, *Space Mission Analysis and Design*, Hawthorne: Microcosm Press, 2010.
2. International Space Station Program, "Pressurized Payloads Interface Requirements Documents," NASA, Houston, 2015.
3. Johnson Space Center, "Crewed Space Vehicle Battery Safety Requirements," National Aeronautics and Space Administration, Houston, 2014.
4. H. E. Frankel, "Effect of Vacuum on Materials," NASA Goddard Space Flight Center, Greenbelt, 1969.
5. C. D. Brown, "Spacecraft Propulsion," American Institute of Aeronautics and Astronautics, Inc., Washington, DC, 1996.
6. Horiba, T. "Lithium-Ion Battery Systems." *Proceedings of the IEEE*, 102(No. 6), 939-950. 2014, June.
7. NanoRacks, "Flight Acceptance Test Requirements for Lithium-ion Cells and Battery Packs," NanoRacks, Webster, 2017.
8. Johnson Space Center, "Guidelines for Assessing the Toxic Hazard of Spacecraft Chemicals and Test Materials," National Aeronautics and Space Administration, Houston, 1997.
9. ASTM International, "Standard Test Method for Total Mass Loss and Collected Volatile Condensable Materials from Outgassing in a

Vacuum Environment," ASTM International, West Conshohocken, 2015.

10. ASTM International, "Standard Test Method for Contamination Outgassing Characteristics of Spacecraft Materials," ASTM International, West Conshohocken, 2016.
11. NASA Goddard Space Flight Center, "General Environmental Verification Standard," National Aeronautics and Space Administration, Greenbelt, 2013.
12. Sebestyen, George; Fujikawa, Steve; Galassi, Nicholas; Chuchra, Alex, "Low Earth Orbit Satellite Design," Springer International Publishing, 2018