

2019

A Safe House for Orphan Parts an Architectural Proposal for a US Center for Illicit Antiquities

Lauren Aguilar

Follow this and additional works at: https://repository.upenn.edu/hp_theses

Part of the [Historic Preservation and Conservation Commons](#)

Suggested Citation:

Aguilar, Lauren (2019). *A Safe House for Orphan Parts an Architectural Proposal for a US Center for Illicit Antiquities* (Masters Thesis). University of Pennsylvania, Philadelphia, PA.

This paper is posted at ScholarlyCommons. https://repository.upenn.edu/hp_theses/685
For more information, please contact repository@pobox.upenn.edu.

A Safe House for Orphan Parts an Architectural Proposal for a US Center for Illicit Antiquities

Abstract

Though very different institutions, the Met, the Getty, and US Immigration and Customs have a striking similarity in one regard. Each holds unmatched collections of antiquities. They focus efforts on study, acquisition, and object transfer. However, the Met and the Getty are renowned museums and ICE recovers and repatriates black market goods, keeping their collection in several top-secret warehouses. One such warehouse in Queens houses over 2,500 seized artifacts including “a huge stone Buddha from India, terracotta horsemen from China, reliefs from Iraq, Syria, and Yemen” Unlike the carefully curated collections at institutions like the Met, these pieces are a wildly varying group of rescues. These looted “parts” become displaced from their site or museum context and either disappear into private collections or spend years in government facilities awaiting repatriation.

In parallel globally and in the United States, the means and methods of war have greatly evolved leaving a vast aging building stock of military orphans. Traditional building typologies including munitions storage, forts, and bunkers have been superseded but are expensive or difficult to demolish. In addition, these spaces are crafted around defensive, introverted narratives. A Safe House for Orphan Parts posits the role of architecture in repatriation and speculates on the proposed relationship between the orphan part and the orphaned building. The project seeks to explore the architectural opportunities to tell the story of looting in relation to terrorism.

Keywords

design, military, bunkers, displacement, storytelling

Disciplines

Historic Preservation and Conservation

Comments

Suggested Citation:

Aguilar, Lauren (2019). *A Safe House for Orphan Parts an Architectural Proposal for a US Center for Illicit Antiquities* (Masters Thesis). University of Pennsylvania, Philadelphia, PA.

*A SAFE HOUSE FOR ORPHAN PARTS
AN ARCHITECTURAL PROPOSAL FOR A US CENTER FOR ILLICIT ANTIQUITIES*

LAUREN ELIZABETH AGUILAR

A THESIS

in

Architecture + Historic Preservation

*Presented to the Faculties of the University of Pennsylvania in Partial Fulfillment of the Requirements of the
Degree of*

MASTER OF ARCHITECTURE

+

MASTER OF SCIENCE IN HISTORIC PRESERVATION

2019

Advisors

Winka Dubbeldam, Miller Professor and Program Chair

Frank G. Matero, Professor and Program Chair

ACKNOWLEDGEMENTS

This thesis wouldn't have been possible without the support of my advisors Winka Dubbeldam and Frank Matero. I'd like to thank them for always believing in me, sharing in my excitement, and pushing me to think critically and design thoughtfully. I've truly had a lot of fun working with Winka and Frank, and appreciate that they've always been on-board and open to my project. Completing a dual thesis comes with an extra set of challenges, but I'm grateful both of my advisors have always seen this as an asset.

I'm also incredibly thankful for my friends Graham Nelson and Lillian Candela, who have listened to all my ideas, calmed my wildest anxieties, and helped me cross the finish line with this project. They've inspired me, believed in me, and kept me grounded as I've worked on this thesis.

This project would not have been possible without the help of the Soane Research Library and Archive who aided my research in London. In addition, I'd like to thank Brian Daniels for meeting with me and advising me on readings, policies, and practices.

I'd also like to thank my parents. I realize that watching your daughter move across the country to "follow her dreams" is tough. Yet, they've always believed in me and assured me that I can get through anything I put my mind to.

While this project marks the end of graduate school for me, I am excited to keep thinking about the questions I've posed and keep growing from this experience.

CONTENTS

iv	FIGURES
01	ABSTRACT
03	QUESTIONS AND METHOD UNDERSTANDING A COLLECTION IN FLUX SITE SELECTION ESTABLISHING A RELATIONSHIP BETWEEN SITE AND COLLECTION DEFINING SPATIAL NARRATIVES ANALYSIS OF IMPLICATIONS
07	LOOTING, THE LAW, AND THE ECONOMY
16	DEFENSIVE ARCHITECTURE AND THE PRACTICE OF WAR BUNKER AS SITE BATTERY 223
32	CASE STUDIES
43	OBJECT AND ARCHITECTURE
47	US CENTER FOR ILLICIT ANTIQUITIES DECEPTION RELIGION TRANSACTIONS AND THE GLOBAL ECONOMY ICONOCLASM AND CULTURAL CLEANSING
72	CONCLUSION
91	BIBLIOGRAPHY
81	APPENDIX A REFERENCE PROJECTS AND SITES
82	APPENDIX B PROGRESS WORK

FIGURES

Figure 1: The current looting terrorism pipeline in Iraq and Syria

Figure 2: Final model speculation

Figure 3: Looting in the Mosul Museum; (Alice Martins, *The Salvation of Mosul* Smithsonian Magazine October 2017)

Figure 4: Timeline of US Policy regarding Repatriation

Figure 5: Map of countries with bilateral trade agreements with the US. The countries in yellow have active agreements. Iraq and Syria, in red, have special sanctions in place. Canada's agreement, in teal, has expired)

Figure 6: Map of countries with highlighting countries of interest in the looting terrorism pipeline. Countries in red are experiencing heavy looting, countries in teal have leaky borders and serve as a second stop. Countries in yellow have active illicit art markets and launder antiquities. Countries in blue comprise 84% of the art market.

Figure 7: Battery 223 in 2004; (he who shall, "WWII Artillery Bunker - Cape May, NJ", flickr 2014)

Figure 8: Bunkers along the Atlantic Coast in Europe, Observed February 2019

Figure 9: Atlantic Wall Bunkers in Europe; (Virilio 2012)

Figure 10: Atlantic Wall Bunkers in Europe

Figure 11: Battery 223, Cape May Point New Jersey; observed March 2019

Figure 12: Historic Photos of artillery bunkers on the US Atlantic Coast during WWII; National Register of Historic Places, Battery 223, Cape May Point, Cape May County, New Jersey, National Register #1024-0018.

Figure 13: Battery 223, Cape May Point New Jersey; Historic Photos from 1950s; National Register of Historic Places, Battery 223, Cape May Point, Cape May County, New Jersey, National Register #1024-0018.

Figure 14: Map showing the location Battery 223

Figure 15: Map showing the location Battery 223

Figure 16: Existing diagrammatic plan and section of batter 223, not to scale

Figure 17: Contemporary Cape May tourism statistics; Cape May tourism board

Figure 18: Bunker 599; observed February 2019

Figure 19: Engraving from Ferrante Imperato, *Dell'Historia Naturale* (Naples 1599) of a natural history cabinet

Figure 20: Display of Parthenon marbles at the British Museum; observed February 2019

Figure 21: Sir John Soane's Museum, photo courtesy of Sir John Soane's Museum

Figure 22: Bunker 599, observed February 2019

Figure 23: Anonyme Project in Dunkirke, France; observed February 2019

Figure 24: Fourth Plinth in Trafalgar Square; observed February 2019

Figure 25: Architectural hostings

Figure 26: Rendering of central hall with niches for objects

Figure 27: Proposed Program

Figure 28: Site plan, not to scale

Figure 29: Ground floor plan, not to scale

Figure 30: Ground floor plan, existing and proposed, not to scale; footprint of existing bunker highlighted in blue, subtractive alterations have been made within the blue envelope, addition exists outside of the the highlighted area

Figure 31: Ground floor plan, galleries in existing bunker (left to right) deception gallery in purple, religion gallery in pink, transactions and the global economy gallery in teal, and iconoclasm and cultural cleansing gallery in yellow not to scale

Figure 32: North-facing Section, not to scale

Figure 33: West-facing Section, not to scale

Figure 34: Axonometric drawing with ceiling cutaway

Figure 35: Elevation rendering

Figure 36: Rendering at the second floor

Figure 37: Rendering at the reception

- Figure 38: Rendering of architectural strategies for deception gallery*
- Figure 39: Rendering of architectural strategies for religion gallery*
- Figure 40: Rendering of architectural strategies for transactions and the global economy gallery*
- Figure 41: Rendering of architectural strategies for iconoclasm and cultural cleansing gallery*
- Figure 42: Rendering of the deception gallery*
- Figure 43: Rendering of the religion gallery*
- Figure 44: Rendering of the transactions and the global economy gallery*
- Figure 45: Rendering of transactions and the main hallway and iconoclasm and cultural cleansing gallery*
- Figure 46: Speculative fragment model*
- Figure 47: Speculative fragment model*
- Figure 48: Speculative fragment model*
- Figure 49: Speculative fragment model*
- Figure 50: Speculative fragment model*

ABSTRACT

Though very different institutions, the Met, the Getty, and US Immigration and Customs have a striking similarity in one regard. Each holds unmatched collections of antiquities. They focus efforts on study, acquisition, and object transfer. However, the Met and the Getty are renowned museums and ICE recovers and repatriates black market goods, keeping their collection in several top-secret warehouses. One such warehouse in Queens houses over 2,500 seized artifacts including “a huge stone Buddha from India, terra-cotta horsemen from China, reliefs from Iraq, Syria, and Yemen”¹ Unlike the carefully curated collections at institutions like the Met, these pieces are a wildly diverse group of rescues. Many of these objects are victims of looting, tied directly to unrest and conflict. Presently, looting is severe in Iraq and Syria. Conflict with ISIS and other terrorist groups has motivated looting as an income generating strategy and has left much heritage unprotected.² These looted “parts” become displaced from their site or museum context and either disappear into private collections or spend years in government facilities awaiting repatriation. (Figure 1)

In parallel, domestically and abroad, the means and methods of war have significantly evolved leaving a large aging building stock of military orphans. Traditional building types including munitions storage, forts, and bunkers have been superseded but are expensive or difficult to demolish. These buildings are remnants from an era with different weapons, technology, and types of conflict and are no longer useful in contemporary conflict conditions. While certain military fortifications are more easily protected or maintained, bunkers are particularly vulnerable to abandonment and neglect due to specialized construction and design.³ Hence, the bunker is the ultimate orphaned building.

This project posits the role of architecture in repatriation and speculates on the proposed relationship between the orphan part and the orphaned building. “A Safe House for Orphan Parts” imagines a hypothetical US Center for Illicit Antiquities. The building seeks to hybridize traits from a vault, a gallery, and an investigative office. Within this system, the project explores the architectural opportunities to tell the story of looting in relation to terrorism.

1 Tom Mueller, “How Tomb Raiders Are Stealing Our History,” National Geographic, May 13, 2016, www.nationalgeographic.com/magazine/2016/06/looting-ancient-blood-antiquities/.

2 Andrew W. Terrill, *Antiquities Destruction and Illicit Sales as Sources of Isis Funding and Propaganda* (Strategic Studies Institute and U.S. Army War College Press, 2017), 17-32.

3 X. Vytuleva, “How to Preserve a Bunker 1 × Unknown (2012-).” (*Future anterior : journal of historic preservation history, theory and criticism* / 12, no. 2 2015) 109–115

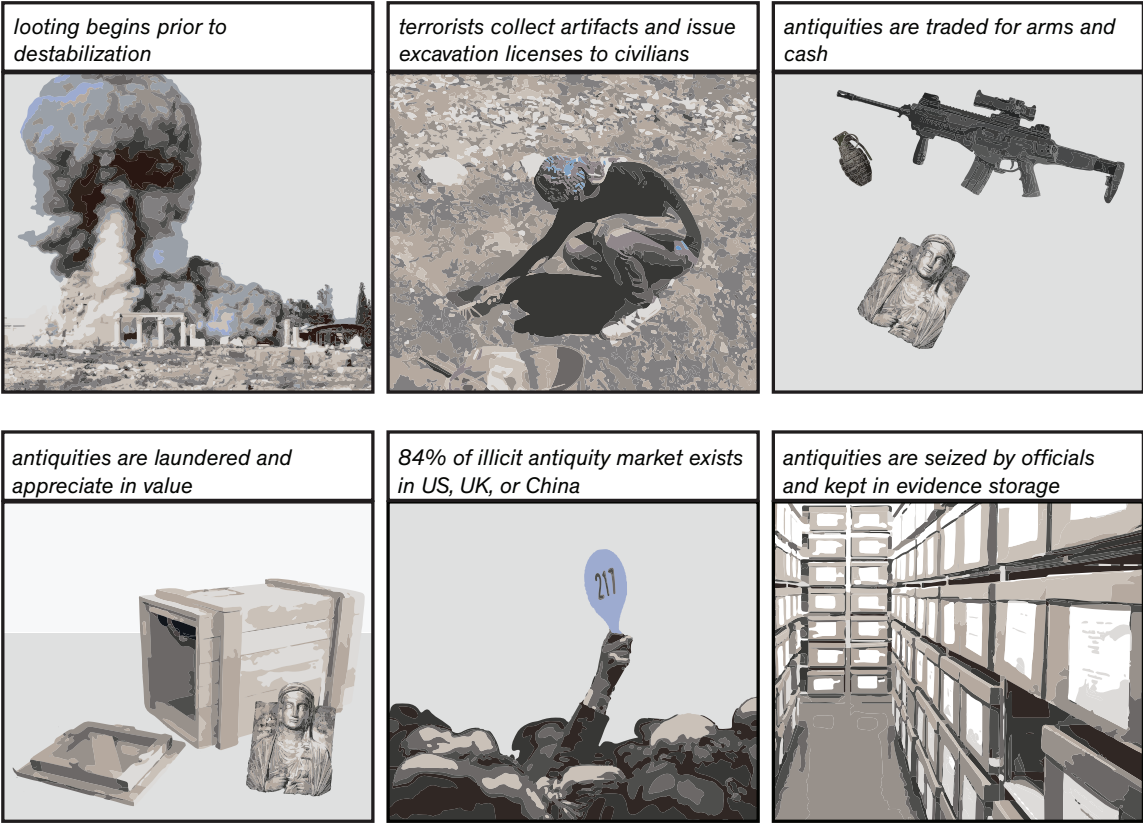

Figure 1: The current looting terrorism pipeline in Iraq and Syria

QUESTIONS AND METHOD

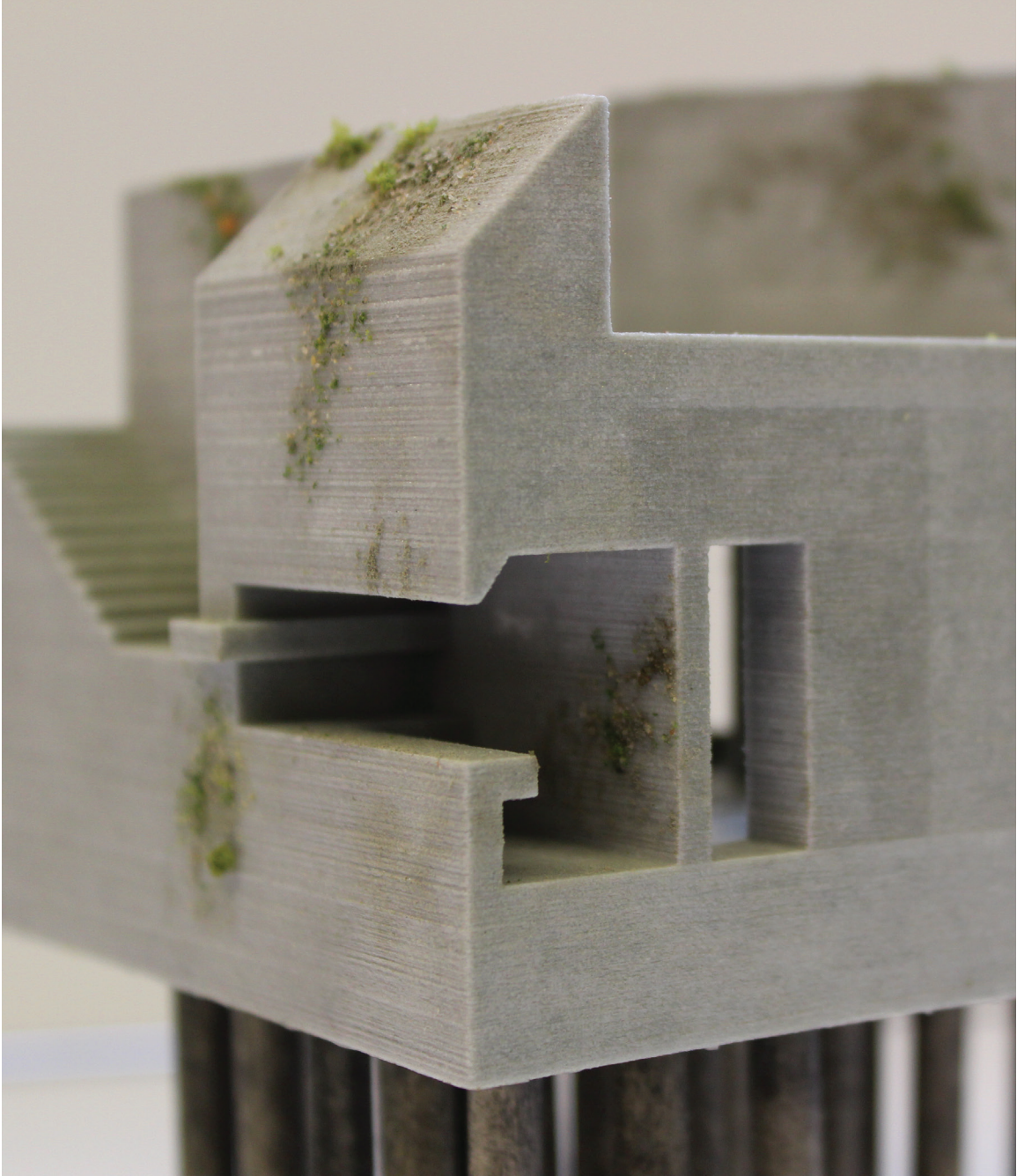

Figure 2: Final model speculation

QUESTIONS AND METHOD

In this thesis I propose the following questions and aim to address them through the design process to produce a project that incites conversation and contributes to the practice of designing for displacement:

How can architecture respond to the looting terrorism pipeline?

In an era that advocates 'world heritage' and 'global understanding,' can illegally displaced heritage be protected and shared with the public at the same time?

Conflict and looting result in displaced and damaged fragments. How can architecture help to mitigate this rupture and the temporary nature of its context? How does the curation, or lack thereof contribute to the meaning and plight of these objects through space-making? How does the architecture contribute to the narrative?

The process for developing the project involves a series of overlapping steps that seek to reconcile the tension between the site and collection, explore architectural strategies for posing spatial narratives, and analyze the implications of changing context. The first phase focuses on collecting and analyzing information on existing conditions, world news, history, geopolitics, and cultural trends. The second phase synthesizes the information through the design process to propose an architectural project that responds to the information through a series of representative drawings and models.

UNDERSTANDING A COLLECTION IN FLUX

First, I investigated how the seizure of looted artifacts is a means of collection. This stage began with reading texts on looting, reading news reports and press releases from ICE, and consulting with professionals at universities, museums, and government agencies. This initial research consists of a broad survey that establishes a scope of objects that could be recovered as victims of looting and war. To build a basis for design, I used this information to speculate on an initial collection, acknowledging its inherent plasticity. The collection is assumed to be in flux because of repatriation, investigation, and conservation. The size and nature of the collection correspond with looting trends and associated confiscation. I used these initial studies to develop a series of questions that would define themes for storytelling.

SITE SELECTION

In parallel to the study of the objects, I selected a site. In this stage, I looked at defensive precedents including munitions storage, bunkers, and forts. I observed the plans and sections and analyzed how their spatial composition impacts the buildings performance and experiential qualities. These sites have an inherent military history, and their implicit narrative should relate to the collection. I kept a list of potential sites and compared their assets. Using information about the objects and information from the plans and sections, I began to form ideas about their relationships. The site and its architecture are understood to serve as a host to the collection, a curator of narratives, and a vessel to contain the objects. Ultimately I selected Battery 223, a World War II-era bunker, in Cape May, New Jersey.

ESTABLISHING A RELATIONSHIP BETWEEN SITE AND COLLECTION

In the following step, I developed a program. I analyzed the site and the collection to assess spatial assets and identify the program's unique spatial needs. This study begins to inform the initial development of the site plan and section. It became clear that the selected bunker did not have enough floor area to support a US Center for Illicit Antiquities. Hence, an addition was necessary. I began to think about which parts of the program were better suited for the bunker and which could be better served by an addition. In this step, I identified and tested more extensive formal interventions. I decided that since the project explored the relationship between the orphaned part and the orphaned building, the storytelling galleries would be in the bunker and the other spaces

would be in the addition. I made schematic design decisions to begin to diagram procession and circulation, formal design strategies, and locations for program. I developed a ground floor plan, several sections, an axonometric drawing, a site plan, and an elevation.

DEFINING SPATIAL NARRATIVES

In parallel, I thought critically about storytelling in space. I selected four themes around which to organize and display objects. These four themes stemmed from the previous research about looted objects histories. The themes function as frameworks on which to base spatial narratives. I had four galleries and designed each to be a backdrop or host for a story. I composed a series of vignettes to test this system and explore the narrative. These drawings will speculate on the spatial character of the galleries and serve as a tool to develop the narratives. Once I developed these instances, I was able to piece them together with the sections and plans.

ANALYSIS OF IMPLICATIONS

Once I had a set of working drawings, I analyzed the resulting spaces. I was able to craft a series of models that cut through multiple stories. Through this representation, I could begin to speculate on the relationship between object, architecture, and story. I imagine the stories and strategies having a life outside of this context and explored that through the fragment models. I was influenced by John Soane in his "Crude Hints toward a History of my House." I feel the models present an alternative understanding of the project and further divorce the context from the design. In the end, the project posed additional questions: Are there other narratives that exist outside of the original characterization? Moreover, how do story-telling moments estrange the design?

LOOTING, THE LAW, AND THE ECONOMY



Figure 3: Looting in the Mosul Museum; (Alice Martins, The Salvation of Mosul Smithsonian Magazine October 2017)

LOOTING, THE LAW, AND THE ECONOMY

During a period of unrest, cultural heritage is difficult to protect and frequently targeted to seize power, generate income, or control culture.⁴ While the practice of looting is not new, the means and methods of looting have adapted along with the means and methods of conflict. Looting has existed within the context of “rape, pillage, plunder;” records indicate looting was an integral part of power seizure for Alexander the Great, the Vikings, and Julius Caesar. By the 17th and 18th centuries, looting was an integral part of colonialization, and collecting artifacts was considered a status symbol. Young, affluent Europeans would travel on a “grand tour” and collect artifacts for their personal collection.⁵

By the 20th century, anthropologists considered the destruction of cultural heritage within the bounds of genocide. Looting was extreme during WWII; the Nazis used looting to control wealth and seize power.⁶ Following the war, in the latter half of the 20th century, governments started to plan repatriation policies beginning with the 1954 Hague Convention for the Protection of Cultural Property in the Event of Armed Conflict.⁷ (Figure 4)

In 1970, UNESCO adopted the Convention on the Means of Prohibiting and Preventing

4 Robert Bevan, *The Destruction of Memory: Architecture at War* (Chicago: The University of Chicago Press, 2006).

5 John Henry Merryman and Albert Edward Elsen, *Law, Ethics, and the Visual Arts*. 4th ed. London: Kluwer Law International, 2002.

6 Lynn H. Nicholas, *The Rape of Europa: The Fate of Europe's Treasures In the Third Reich and the Second World War*. (New York: Knopf, 1994)

7 Patty Gerstenblith, “The Destruction of Cultural Heritage: A Crime Against Property or a Crime Against People,” *The John Marshall Review of Intellectual Property Law*, no. 15 (2016); The Convention lays out the basic principles for protecting cultural property. It begins with a Preamble, which sets out the reasons for the adoption of the Convention. It is worth noting two of the introductory paragraphs in particular: Being convinced that damage to cultural property belonging to any people whatsoever means damage to the cultural heritage of all mankind, since each people makes its contribution to the culture of the world; Considering that the preservation of the cultural heritage is of great importance for all peoples of the world and that it is important that this heritage should receive international protection.(Gerstenblith 2016)



Figure 4: Timeline of US Policy regarding Repatriation

the Illicit Import, Export, and Transfer of Ownership of Cultural Property.⁸ To date, 131 countries have signed it, agreeing to take measure to prevent and end illegal antiquity trade and return seized contraband to its home. However, the US did not begin implementing the agreement with legislation until 1983 when the US passed the Convention on Cultural Property Implementation Act. (Figure 5) This act establishes a process by which the US can pursue bilateral agreements with other countries to restrict trade.⁹ Furthermore, in 2001 the United States vs. Schultz Case applied the National Stolen Property Act to illicit antiquities.¹⁰ The National Stolen Property Act (18 U.S.C. §§ 2314-2315) prohibits the transportation in interstate or foreign commerce of any goods with a value of \$5,000 or more with the knowledge that they were illegally obtained.¹¹ To further coordinate repatriation efforts across federal agencies and block trafficking, the US established the Cultural Antiquities Task Force in 2004. Since 2007, the U.S. has returned over 11,000 artifacts to 30 countries.¹²

Today, objects are still looted in unstable areas, with severe looting in Iraq and Syria. Before and during civil unrest, normal economic activity is destabilized, and individuals resort

8 The agreement states: (i) to prohibit the import of cultural property stolen from a museum or a religious or secular public monument or similar institution in another State Party to this Convention after the entry into force of this Convention for the States concerned, provided that such property is documented as appertaining to the inventory of that institution; (ii) at the request of the State Party of origin, to take appropriate steps to recover and return any such cultural property imported after the entry into force of this Convention in both States concerned, provided, however, that the requesting State shall pay just compensation to an innocent purchaser or to a person who has valid title to that property. Requests for recovery and return shall be made through diplomatic offices. The requesting Party shall furnish, at its expense, the documentation and other evidence necessary to establish its claim for recovery and return. The Parties shall impose no customs duties or other charges upon cultural property returned pursuant to this Article. All expenses incident to the return and delivery of the cultural property shall be borne by the requesting Party.

9 In 1986, the President signed Executive Order 12555 to delegate executive authority to the Director of the U.S. Information Agency for carrying out certain provisions of section 303 and 304 of the Convention on Cultural Property Implementation Act. In 1998, the US passes In the Foreign Affairs Reform and Restructuring Act, delegating authority to the Secretary of State. By 2002, the US passes the Homeland Security Act. The Homeland Security Act establishes Homeland Security Investigations. Most recently, in 2016, the US signed a new law, HR1493 the Protect and Preserve Cultural Property Act.

10 Alessandro Chechi, Anne Laure Bandle, Marc-André Renold, "Case Egyptian Archaeological Objects – United States v. Frederick Schultz," Platform ArtThemis (<http://unige.ch/art-adr>), Art-Law Centre, University of Geneva.

11 National Stolen Property Act Agencies Et Seq, <https://coast.noaa.gov/data/Documents/OceanLawSearch/Summary%20of%20Law%20-%20Na>

12 "Cultural Property, Art and Antiquities Investigations." ICE, 11 Sept. 2018, www.ice.gov/features/cpa.

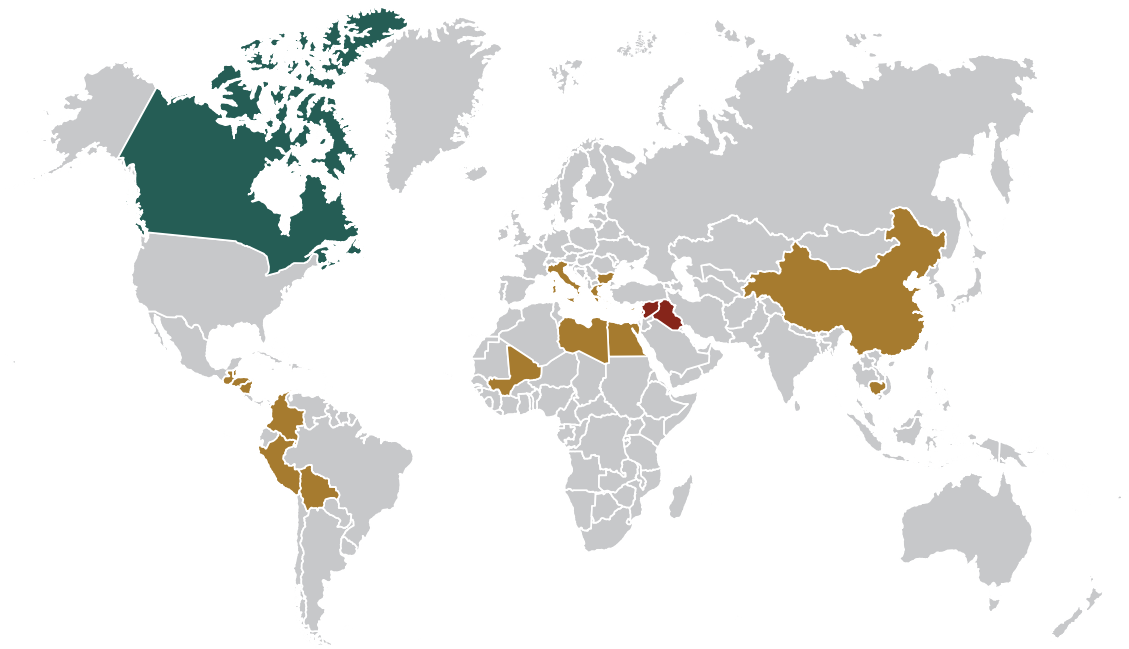

Figure 5: Map of countries with bilateral trade agreements with the US. The countries in yellow have active agreements. Iraq and Syria, in red, have special sanctions in place. Canada's agreement, in teal, has expired)

to looting to replace lost income.¹³ In parallel to individual efforts, organized crime cartels and terrorist organizations use looting as an income generating strategy.¹⁴ Also, terrorist organizations sometimes issue excavation licenses or charge taxes to civilians who engage in looting.¹⁵ Typically, the initial looter profits the least.¹⁶ Eventually, the object is smuggled out of the country to integrate into more profitable art markets. As the objects are transported across borders, they are laundered to falsify records. Laundering increases an object's value an estimated 60-100%. Eventually, these objects make their way to the US, the UK, or China; 83% of the wealth in the illegal antiquity market is traded in these three countries.¹⁷ (Figure 6) The rise of the digital age enables and globalizes this trade as more artifacts are found on e-commerce sites including Amazon and eBay.¹⁸

If a looted object is imported to the US, it is confiscated if Immigrations and Customs can prove probable cause that the object has been imported illegally. Probable cause would include if the parties involved lied about the import, were importing an object originating from a country the US has a bilateral agreement with, or if the object were linked to known crimes. If Immigration and Customs can determine probable cause, they confiscate the object, and the Department

13 Sarah Parcak, David Gathings, Chase Childs, Greg Mumford, and Eric Cline. "Satellite Evidence of Archaeological Site Looting in Egypt: 2002–2013." (*Antiquity* 90, no. 349, 2016) 188–205.

14 P. Campbell, "The Illicit Antiquities Trade as a Transnational Criminal Network: Characterizing and Anticipating Trafficking of Cultural Heritage" (*International Journal of Cultural Property*, 20(2), 2013) 113-153

15 Andrew W. Terrill, *Antiquities Destruction and Illicit Sales as Sources of Isis Funding and Propaganda* (Strategic Studies Institute and U.S. Army War College Press, 2017), 17-32.<http://www.jstor.org/stable/resrep11436>.

16 Patty Gerstenblith, "Controlling the International Market in Antiquities: Reducing the Harm, Preserving the Past" (*Chicago Journal of International Law* 8 2007) 169-195; "While it is difficult to obtain first-hand information as to the price of looted antiquities paid at the source, the journalist Joanne Farchakh reported in May 2004 that at archaeological sites in southern Iraq a cuneiform tablet would sell for four dollars, a decorated vase would sell for between twenty and fifty dollars, and a sculpture would sell for about one hundred dollars. In Baghdad, the journalist Joseph Braude paid two hundred dollars for each of three cylinder seals looted from the Iraq Museum. In comparison, cylinder seals sold on the market in London or New York have an average value of one thousand dollars. A recent cursory survey of comparable objects being offered on eBay showed that cylinder seals were priced at \$350 to \$2,000; cuneiform tablets were offered at a range of \$350 up to £550 (approximately equivalent to \$1027). A recent Christie's catalogue gave high and low estimates of \$1200 and \$1800 for a cuneiform envelope and tablet, but it sold for \$10,800." (Gerstenblith 2007)

17 Samuel Andrew Hardy, "Illicit Trafficking, Provenance Research and Due Diligence: the State of Art" (UNESCO 2016)

18 Jennifer Anglim Kreder and Jason Nintrup, *Antiquity Meets the Modern Age: eBay's Potential Criminal Liability for Counterfeit and Stolen International Antiquity Sales*, (5 Case W. Res. J.L. Tech. & Internet 143 2014)

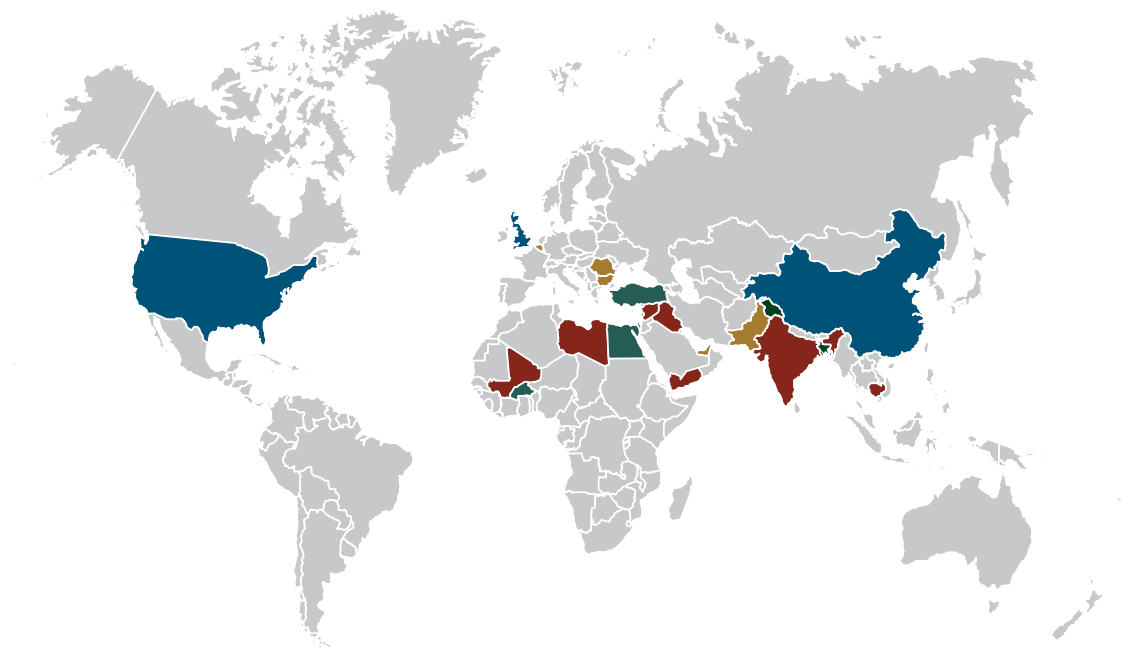

Figure 6: Map of countries with highlighting countries of interest in the looting terrorism pipeline. Countries in red are experiencing heavy looting, countries in teal have leaky borders and serve as a second stop. Countries in yellow have active illicit art markets and launder antiquities. Countries in blue comprise 84% of the art market.

of Homeland Security investigates the supply chain.¹⁹ While this investigation takes place, the objects remain in government custody in evidence storage with a protected location. Once an investigation is closed, Immigration and Customs work with the US Marshall and original owner to repatriate the object. Because these investigations and repatriation take time, objects can remain in custody for many years. For example, in 2018, U.S. Immigration and Customs returned over 3,800 ancient artifacts to Iraq, the artifacts had been smuggled into the U.S. in 2010 by arts and crafts retailer, Hobby Lobby. Hence, the artifacts sat in US custody for eight years. According to authorities, Hobby Lobby paid 1.6 million dollars for the antiquities and was fined \$3 million by I.C.E.²⁰

In the US, if an object is proven to be looted the title is invalid. However, if the owner purchased the piece in good faith, the owner can sometimes submit a claim to title insurance to recover costs.²¹ Homeland security investigates the supply chain and fines those responsible.²²

As noted above, there are thousands of confiscated objects in government custody. The types of objects in custody are cases with established probable cause. They remain in storage for extended lengths of time while investigations drag on. The types of objects in custody are directly related to import laws.²³ Looting, however, is dependent on economic trends, geopolitical status, and crime networks. Hence, the types of objects in custody are objects that were looted to satisfy supply and demand and broke contemporary import laws.

In brief, the development of US practices for investigation and repatriation of illicit antiquities is relatively recent and could be considered inefficient. Spatially, there are opportunities to purpose-build a facility that consolidates the confiscation and repatriation processes. This building would serve as a civic building for public education on the illegal art market and facilitate more efficient workflows and collaborations. While all the above goals were considered in designing a proposal for a US Center for Illicit Antiquities, this proposal focuses most acutely on

19 Roehrenbeck, Carol A, "Repatriation of Cultural Property—Who Owns the Past? An Introduction to Approaches and to Selected Statutory Instruments," (International Journal of Legal Information: Vol. 38: Iss. 2, Article 11 2010)

20 John Bacon, "Hobby Lobby antiquities returned to Iraqi officials." (USA Today, May 4, 2018, 06A)

21 Alan Schwartz, "Rethinking the Laws of Good Faith Purchase" (Faculty Scholarship Series. 2011) 4166.https://digitalcommons.lawyale.edu/fss_papers/4166

22 "Cultural Property, Art and Antiquities Investigations." ICE, 11 Sept. 2018, www.ice.gov/features/cpa.

23 Lawrence Rothfield. *Antiquities Under Siege: Cultural Heritage Protection After the Iraq War*. (Lanham, MD: AltaMira Press, 2008)

the center's potential to serve as a civic building for public education and awareness of the illegal art market. The project speculates on architecture's capacity to illuminate stories. In the case of illicit antiquities, the objects have stories inherent to their journey. The architect can design spaces that consider and illuminate these contemporary stories.

DEFENSIVE ARCHITECTURE AND THE PRACTICE OF WAR



Figure 7: Battery 223 in 2004; (he who shall, WWII Artillery Bunker - Cape May, NJ, flickr 2014)

DEFENSIVE ARCHITECTURE AND THE PRACTICE OF WAR

The bunker typology is a subset of defensive architecture with the primary goal of protection in the event of an attack. The means of protection are dependent on weapon technology, predicted attack strategy, and military capacity at the time of construction. Generally, there are five different types of bunkers: trench or pillbox bunkers, artillery bunkers, industrial bunkers, personal bunkers, and munitions storage. The trench or pillbox bunker is typically a small fortification partially set in the ground with apertures above ground to allow firing, these could be prefabricated and could be connected to a trench network. An artillery bunker houses a sizeable permanent weapon, a small team, and infrastructure needed to fire the weapon. The batteries constructed as part of the Atlantic Wall and the Harbor Defenses of the Delaware are artillery bunkers. (Figure 8) Industrial bunkers are built for storage or planning. This includes data storage, food storage, medical supply storage or treatment, mission control rooms, and government operation. Personal bunkers are exclusively living quarters; this includes a safe room or personal residence. Munitions storage house explosives, ammunition, or radioactive debris.²⁴

24 Virilio, Paul. Bunker Archeology. Princeton Architectural Press, 2012.



Figure 8: Bunkers along the Atlantic Coast in Europe, Observed February 2019

Advancements in technology during the Industrial Revolution, followed by World War I prompted a global shift in the practice of war. The Industrial Revolution mobilized the workforce and enabled the production of bigger, standardized, and specialized military technology. As a result, World War I marked a rise in the scale, destruction, and devastation from war.²⁵ The development and use of automatic weapons, tanks, chemical warfare and explosives including bombs and grenades prompted more comprehensive and permanent blast protection. Concrete was determined to be the most cost effective, time efficient, and high performing material to use. Later, concurrently and in anticipation of World War II, militaries constructed additional bunkers to bolster defense and respond to further advancement including airplanes and improved explosives. Initially, following World War II and the development of the nuclear and hydrogen bomb, bunker construction increased. To optimize design and construction, these bunkers use standardized designs and prefabricated hardware.²⁶ Fearing nuclear war, governments and individuals constructed bunkers to withstand nuclear fallout.²⁷ Since then, the power of explosives has increased, but the nature of war has changed. Robotics and drones have lessened the need for manpower in the field, reliance on computers motivates cyber-attacks, and the globalized economy complicates conflict between nation-states.²⁸ Hence, the twentieth-century bunker has been rendered obsolete. Close range manpower is not needed to fire weapons, large scale permanent guns are impractical, and structures have outdated mechanical systems, digital infrastructure, and blast protection. However, these bunkers are cumbersome and expensive to demolish and, arguably, preserve an important part of military history.²⁹

25 Wakounig, Marija. *From the Industrial Revolution to World War II in East Central Europe* /. Berlin :: Lit, 2011.

26 Virilio, Paul. *Bunker Archeology*. Princeton Architectural Press, 2012.

27 Monteyne, David. *Fallout Shelter: Designing for Civil Defense In the Cold War*. Minneapolis [Minn.]: University of Minnesota Press, 2011

28 Hinman, E. (n.d.). *Defensive design: Design for security and mitigating potential terrorist attacks*. *The Routledge companion for architecture design and practice: established and emerging trends* /. New York, NY:: Routledge., doi:10.4324/9781315775869

29 Vytuleva, X. "How to Preserve a Bunker 1 × Unknown (2012-)." *Future anterior : journal of historic preservation history, theory and criticism* / 12, no. 2 (2015): 109–115

BUNKER AS SITE

Twentieth-century bunkers have thick concrete walls with steel hardware, limited apertures, and minimal finishes.³⁰ The interior separates the occupant from a perceived threat affecting the exterior. Hence, there is no visual, auditory, or temperate relationship between the interior and the exterior context. While the bunker exists in geographic location, it is otherwise detached in experience. This detachment renders the space a heterotopia and enables self-reference.^{31 32 33} The bunker exists as an object in the landscape that functions as a space. The interior is separate from any exterior context, so the interior exists as a separate environment. This separation enables the bunker's architecture to be self-referential. (Figure 9) (Figure 10)

Yet, bunkers are built under the pretense of war and conflict. For a bunker to make sense, the inside is constructed to maximize safety from a perceived threat or danger outside. Hence, bunker construction is the architectural manifestation of paranoia.³⁴ The mass is a means to detach the interior from the perceived threat. The architecture suggests conflict at an industrial scale. Today in their abandonment, bunkers are monuments to conflict. In the context of this project, the bunker provides an isolated environment, a conflict-based narrative as a backdrop, and an opportunity for preservation.

30 Ibid.

31 Foucault, Michel, and Jay Miskowiec. "Of Other Spaces." *Diacritics* 16, no. 1 (1986): 22-27. doi:10.2307/464648.

32 A heterotopia, discussed at length in French philosopher, Michel Foucault's, works, first in the *Order of Things* and again in his 1975 book *Discipline and Punish*

33 A heterotopia refers to paradoxical spaces that are self-referential, autonomous, and take on characteristics of a tangible utopia

34 Monteyne, David. *Fallout Shelter: Designing for Civil Defense In the Cold War*. Minneapolis [Minn.]: University of Minnesota Press, 2011

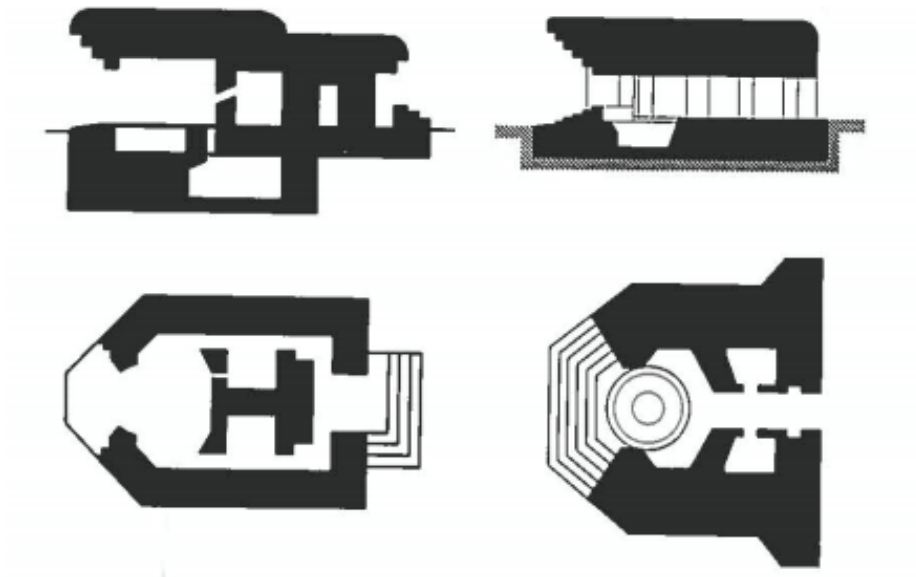

Figure 9: Atlantic Wall Bunkers in Europe; (Virilio 2012)



Figure 10: Atlantic Wall Bunkers in Europe

BATTERY 223

Battery 223 (Figure 11) is located on the beach at Cape May Point in Southern New Jersey. (Figure 14)(Figure 15) Construction began in 1942 and was completed in 1943 as part of the Harbor Defenses of the Delaware. It is constructed exclusively with “thick reinforced concrete with a substantial blast proof roof.” It has a long corridor running parallel with the shoreline and all rooms extend from the corridor south. The center block of rooms “has twenty rooms including several shell rooms, a plotting room, a switchboard room, a latrine and a chemical warfare room among other features.” The structure has two adjacent gun pads, both of which initially housed 6” guns that could fire at targets as far as nine miles away.³⁵ (Figure 13)

The construction of Battery 223 was part of the United States' 1940 Modernization of the Coastal Defense. This program was prompted by advances in weapon technology and the threat of World War II; it sparked new construction and modernization along the east and west coast. (Figure 12) All new construction was standardized, batteries like Battery 223 were all reinforced concrete, all-terrain covered, were set distances from residences, and were connected via telecommunications to facilitate a network for defense. Battery 223 was part of the nearby Fort Miles complex. Construction began on Fort Miles in 1941; the fort sits at the mouth of the Delaware Bay and acts as the first defense for Fort Saulsbury, Fort Mott, Fort DuPont, Fort Delaware, Fort Mifflin, and the city of Philadelphia. During the war, a team of at least sixteen men worked in the battery to man the guns. The guns were never fired as a defense, only for testing and practice.³⁶

35 National Register of Historic Places, Battery 223, Cape May Point, Cape May County, New Jersey, National Register #1024-0018.

36 Ibid.



Figure 11: Battery 223, Cape May Point New Jersey; observed March 2019

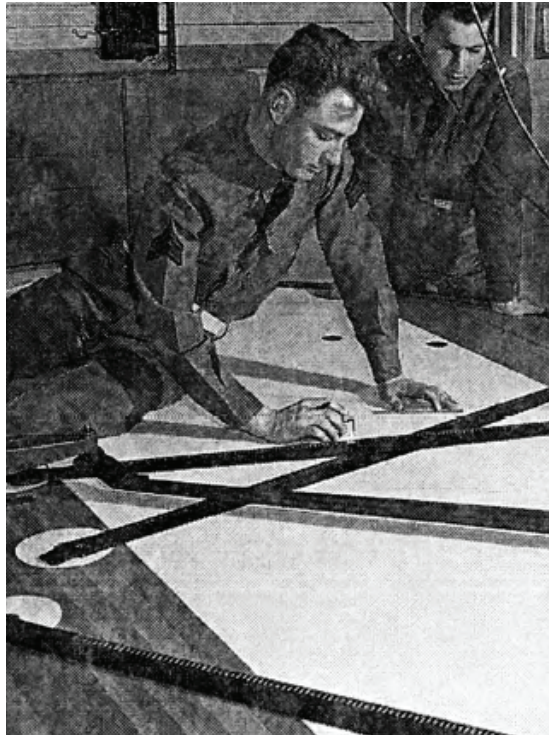
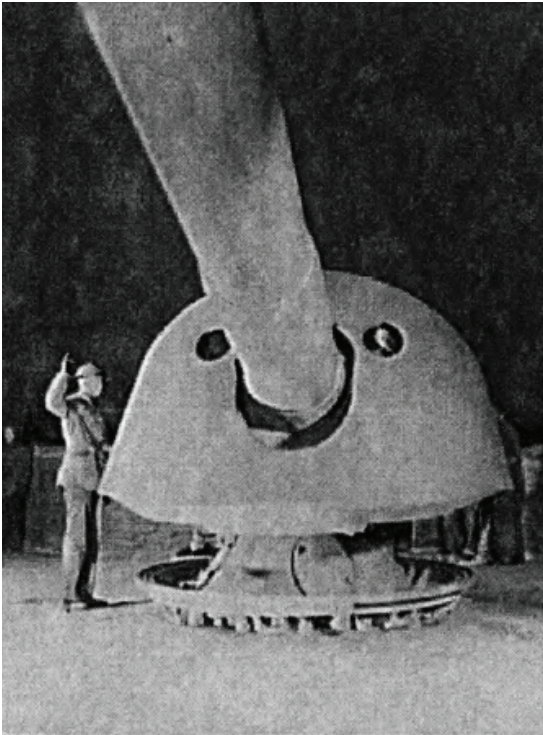

Figure 12: Historic Photos of artillery bunkers on the US Atlantic Coast during WWII; National Register of Historic Places, Battery 223, Cape May Point, Cape May County, New Jersey, National Register #1024-0018.



Figure 13: Battery 223, Cape May Point New Jersey; Historic Photos from 1950s; National Register of Historic Places, Battery 223, Cape May Point, Cape May County, New Jersey, National Register #1024-0018.

Following the war, Battery 223 was decommissioned in 1944, and the guns were declared scrapped by 1950. In 1953, the navy took over the facility for radio communication but abandoned the post in 1964. In 1962, the site became part of the Cape May Point State Park.³⁷ Though the building was originally constructed 900 feet from the shore with sand covering, maintenance and severe erosion washed away its sand covering and exposed the pilings in the 1970s. However, by 2005 the most extensive beach replenishment campaign ever brought 1.4 million cubic yards of sand to Cape May. The campaign calls for additional sand to be added every four years. As a result, the piles remain covered.³⁸ Today it is included on the National Register of Historic Places and the New Jersey Register of Historic Places, although it remains vacant and boarded up.³⁹ (Figure 17)

37 Ibid.

38 Casey Hedrick, "State, Territory, and Commonwealth Beach Nourishment Programs A National Overview" (Office of Ocean & Coastal Resource Management, National Ocean Service National Oceanic & Atmospheric Administration, U.S. Department of Commerce, OCRM Program Policy Series Technical Document No. 00-01 March 2000)

39 National Register of Historic Places, Battery 223, Cape May Point, Cape May County, New Jersey, National Register #1024-0018.; Condition observed March 2019

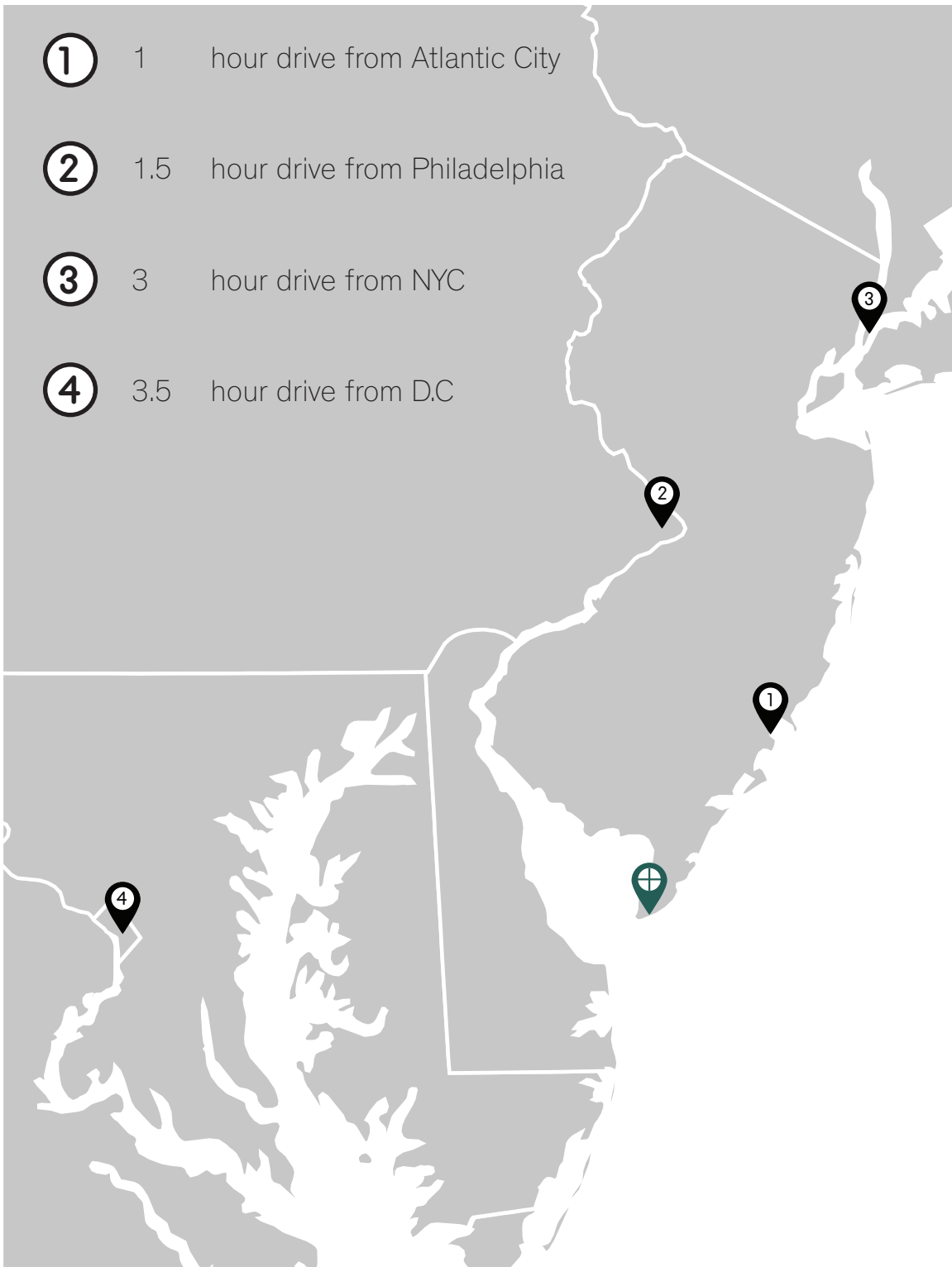

Figure 14: Map showing the location Battery 223



Figure 15: Map showing the location Battery 223

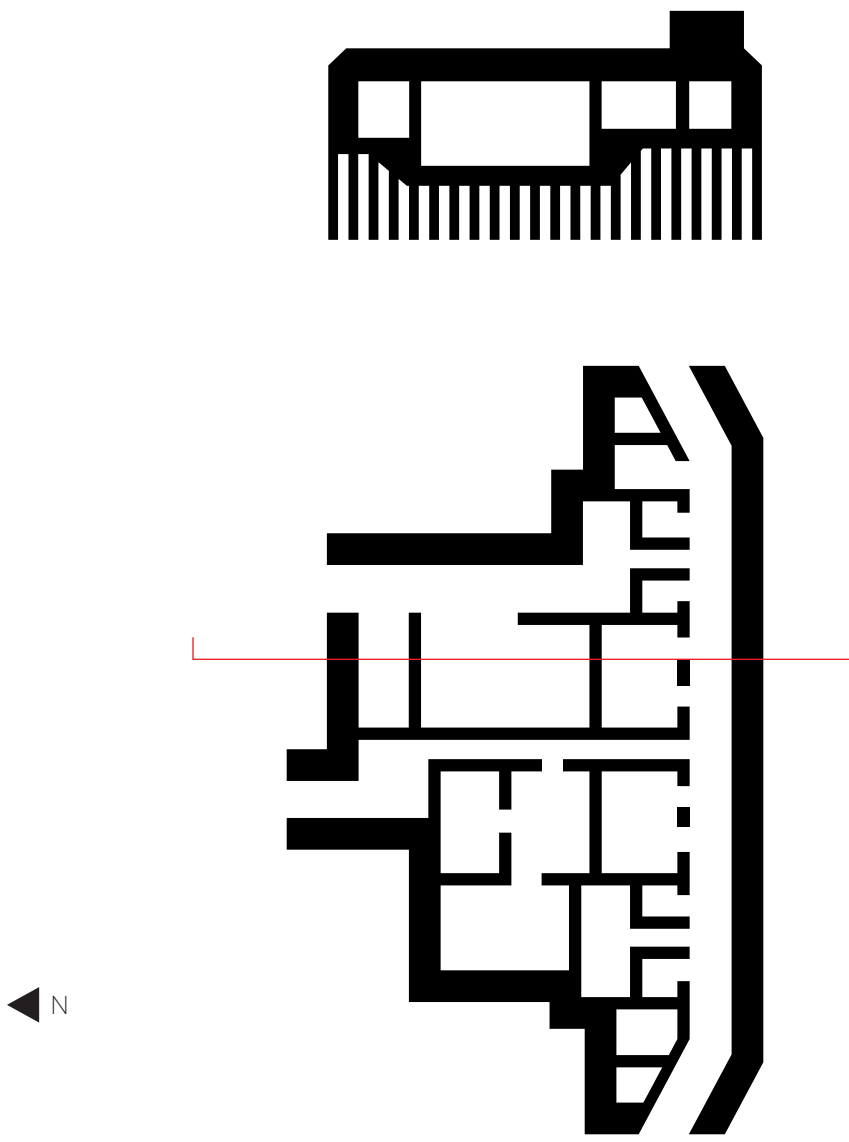

Figure 16: Existing diagrammatic plan and section of batter 223, not to scale

12.5 million tourists

come to Cape May County every year

200,000+

visitors/yr

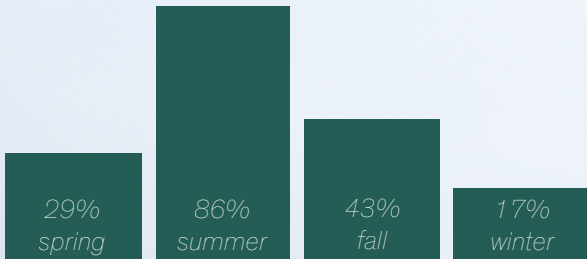

...mostly in the summer

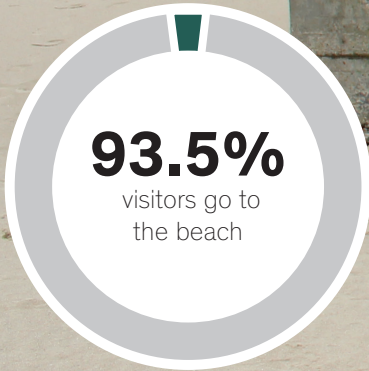
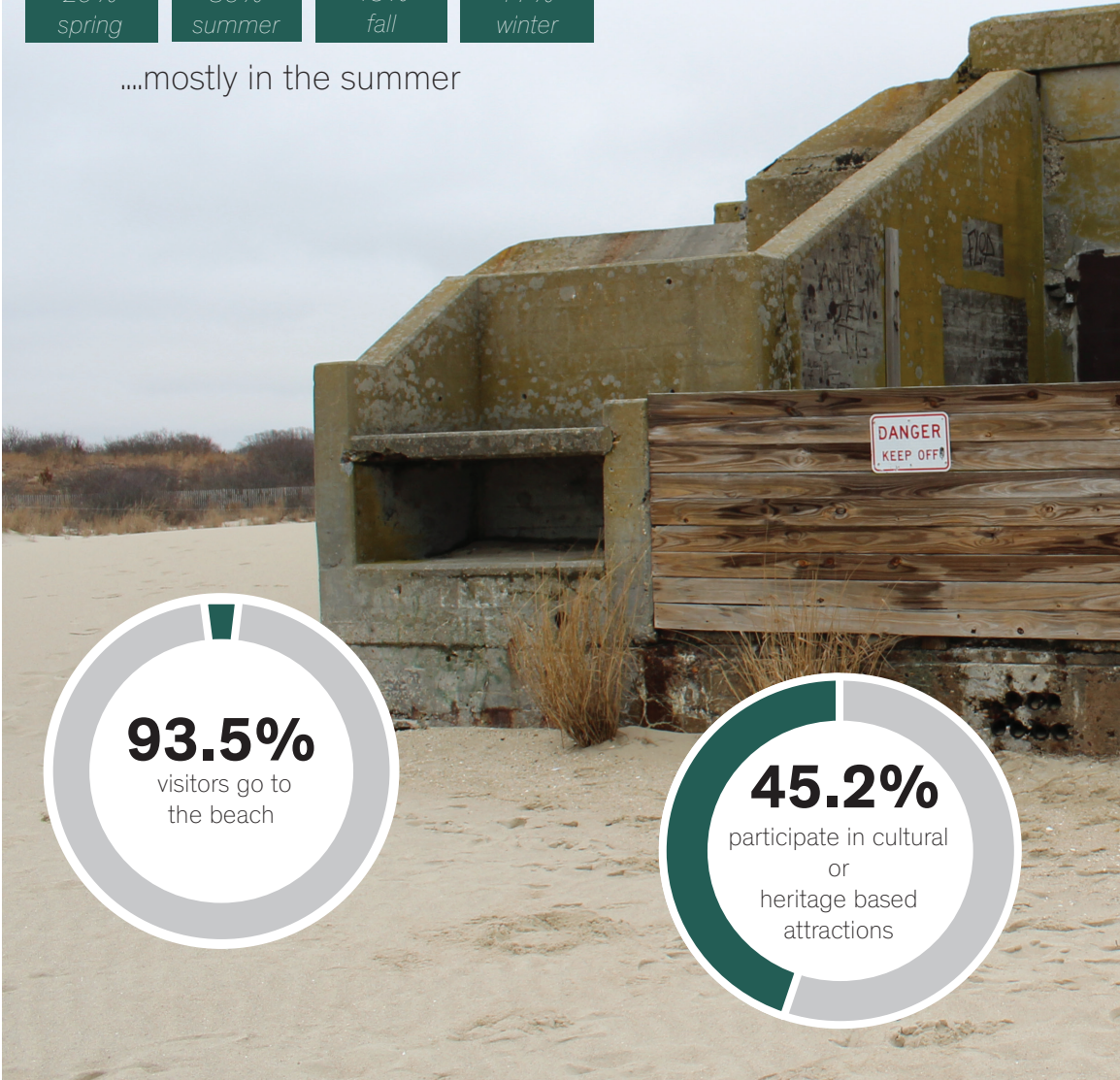

Figure 17: Contemporary Cape May tourism statistics; Cape May tourism board

CASE STUDIES



Figure 18: Bunker 599; observed February 2019

CASE STUDIES

In order to develop architectural strategies for object housing, it is critical to understand how existing related buildings perform. Contemporary curation emerges from the “cabinet of curiosities” and “wunderkammer” of 16th century Europe. Before the rise of public museums, private collectors kept objects within the home. Once curation was institutionalized by public museums and universities, it took on taxonomic characteristics that mirror thought from the scientific revolution and idiosyncratic characteristics that mirror thought from the enlightenment era.⁴⁰ (Figure 19)

For this study, in a taxonomic display, objects are often arranged chronologically or geographically, and the individual objects are typically treated as autonomous members of a collection grouping. These collections are notoriously expansive and exhaustive. The British Museum, the Egyptian Museum, and the Metropolitan Museum of Art are all examples of spaces that engage in taxonomic display. These types of museums have comprehensive collections and display objects to show mastery over history; they are typically public institutions.⁴¹ In the case of a proposed US Center for Illicit Antiquities, the collection would not be exhaustive, and it would be inappropriate to display mastery over history. However, the US Center for Illicit Antiquities would be a civic building with institutional qualities.

In contrast, the idiosyncratic method of display is much looser and gives less attention to the individual object and more attention to overall or grouped collection characteristics. Examples of this type of curation include Sir John Soane's Museum, the Barnes Museum, and the Isabella Stewart Gardner Museum. These collections are less extensive and display objects to communicate taste; they are typically private collections.⁴² In the case of a proposed US Center for Illicit Antiquities, the objects would not be collected based on taste and would not be private. However, the US Center for Illicit Antiquities would have an eclectic collection with a nontraditional display.⁴³ While these cases represent extremes, still, other museums blend taxonomic and idiosyncratic

40 Paul Grinke, *From Wunderkammer to Museum*. Rev. and expanded ed, (London: Quaritch, 2006)

41 James Cuno, *Who Owns Antiquity?: Museums and the Battle Over Our Ancient Heritage* (Princeton: Princeton University Press, 2010)

42 Erin L Thompson, *Possession : the Curious History of Private Collectors from Antiquity to the Present* (New Haven, Yale University Press, 2016)

43 Nontraditional display refers to display that departs from chronological or geographic.

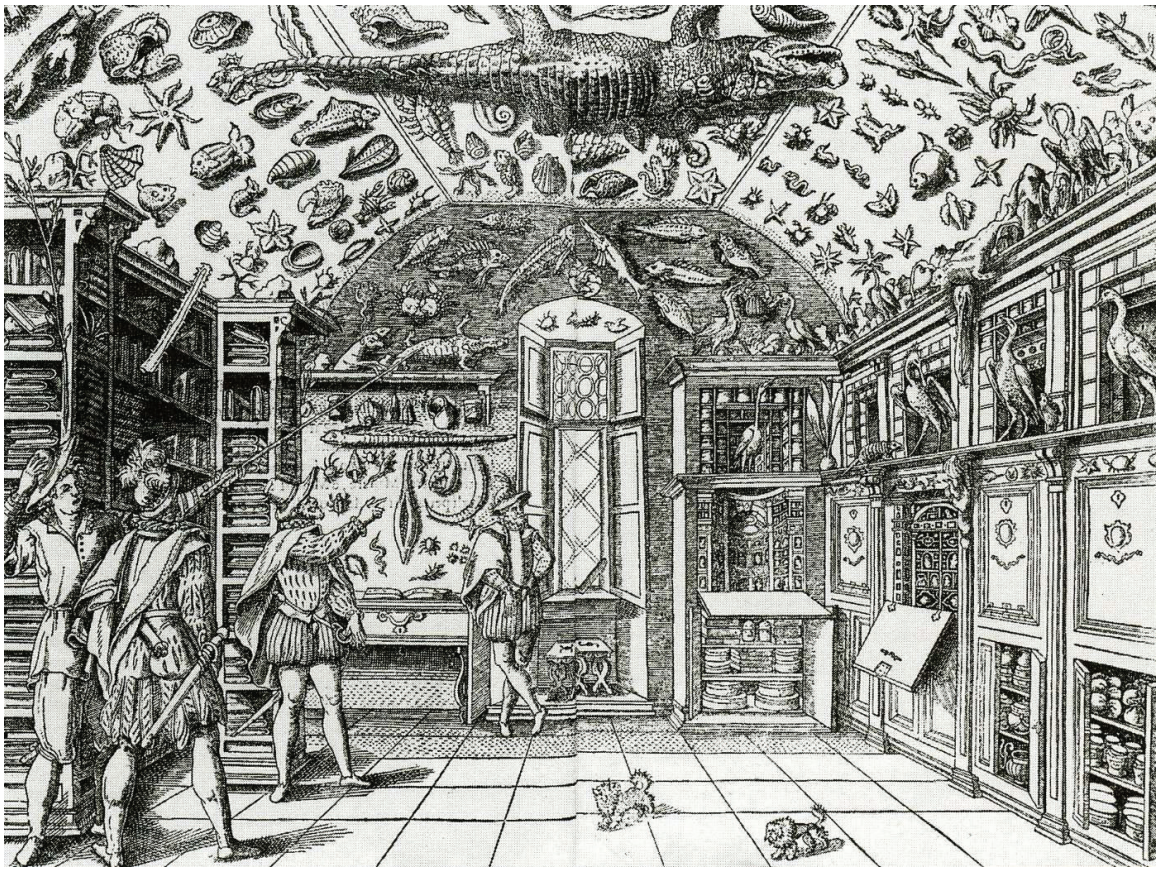

Figure 19: Engraving from Ferrante Imperato, *Dell'Historia Naturale* (Naples 1599) of a natural history cabinet

methods of curation.⁴⁴ In this case, the British Museum and Sir John Soane's Museum are critical case studies to compare the spectrum of curatorial narratives.⁴⁵

The British National Museum was established in 1753 when Sir Hans Sloane sold his personal collection to the state for £20,000; Parliament passed the British Museum Act of 1753. The collection grew to reflect British imperialism and the spirit of the grand tour, and today contains over 8 million objects. Per British law, the museum charges no admission.⁴⁶

The objects in the British Museum are spatially arranged geographically and grouped chronologically. The galleries are discreet rooms that delineate groups within the collection. Hence, the objects are displayed as a taxonomy for the development of civilization. Minimal information accompanies objects in the form of brief text, sometimes in multiple languages.⁴⁷ (Figure 20)

In some areas, this tradition is disrupted. There are several stations throughout the museums in which volunteers have small groups of objects available for visitors to handle. The volunteers have stories about the artifacts and contextual materials including historic photos. In other areas, there are modern replicas that further contextualize an object. Furthermore, in the Assyrian gallery, the British Museum displays a pair of Lammasu.⁴⁸ Immediately adjacent, the British Museum displays a smaller contemporary Lamassu, designed by Michael Rakowitz to interpret conflict and provide alternative context.⁴⁹

Sir John Soane's Museum was established in 1837 following Sir John Soane's death. In the years leading up to his death, Soane, an esteemed architect, opened his house to students as an Academy of Architecture. He hoped his collection would aid their studies and after his death could serve as a museum for "education and inspiration." The collection contains approximately 45,000 objects and remains mostly unchanged since 1837.⁵⁰ Soane curated his collection to

44 The Louvre Lens and Cité de l'architecture et du Patrimoine are notable examples that combine taxonomic and idiosyncratic methods of curation.

45 Author conducted initial site research of these case studies through a field visit in February 2019

46 David M. Wilson, *The British Museum: A History* (London: The British Museum Press, 2002)

47 Observed February 2019

48 In 2015 ISIS publicly destroyed the Lamassu at the Nergal Gate of Ninevah. In 2018, artist Michael Rakowitz created *The Invisible Enemy Should Not Exist* for the Trafalgar Square's fourth plinth. The piece is a full-scale reconstructed Lamassu crafted from Iraqi date cans to draw parallels between heritage production and the loss of agricultural industry in the wake of war.

49 Observed February 2019

50 *A New Description of Sir John Soane's Museum*. 9th rev. ed. London, The Trustees, 1991



Figure 20: Display of Parthenon marbles at the British Museum; observed February 2019



Figure 21: Sir John Soane's Museum, photo courtesy of Sir John Soane's Museum

connect the architecture with the objects as a single composition.⁵¹ He later published *Crude Hints towards an History of my House* in which he imagines his house as a future ruin and poses that future visitors would assume that the house was previously inhabited by a monk, an architect, a lawyer, and a magician. He asserts that the spaces have discreet characteristics that communicate use.⁵² (Figure 21)

In his journals, he speculates on the relationship between architecture and sculpture. He poses that the two are not so different and that there are opportunities for their relationship to be symbiotic. He describes designing his house and displaying his collection as an exercise in architectural design and explains that he aims to use both the house and the collection to enrich each other.^{53 54}

Sir John Soane's Museum and the British Museum represent two extreme examples of different types of curation and display. The Soane Museum is an eclectic curation of objects with a direct relationship with the architecture. Conversely, the British Museum is designed more like a library for artifacts. These curation methods begin to define architectural strategies on which to base future design. To be successful, the proposed US Center for Illicit Antiquities needs to take on characteristics from both spaces.

Since the project is housed in an existing bunker, it was essential to study projects composed with adapted bunkers. Bunker 599 in the Netherlands and the Anonyme project in Dunkirk are two such projects that speculate on orphaned bunker futures.

51 John Britton, 1771-1857. *The Union of Architecture, Sculpture, And Painting: Exemplified by a Series of Illustrations, With Descriptive Accounts of the House And Galleries of John Soane*, (London: The author, 1827)

52 John Soane, *Crude Hints Toward an History of My House* in Lincoln's Inn Fields, 2013.

53 John Britton, 1771-1857. *The Union of Architecture, Sculpture, And Painting: Exemplified by a Series of Illustrations, With Descriptive Accounts of the House And Galleries of John Soane*, (London: The author, 1827)

54 Observed February 2019



Figure 22: Bunker 599, observed February 2019

Bunker 599 was built in 1940 outside of Utrecht as part of the final installment of the New Dutch Waterline. Initially, the pillbox bunker was part of a network of fortifications built to protect Muiden, Utrecht, Vreeswijk, and Gorinchem from invasion. During its initial use as a bunker as many as thirteen men could seek shelter inside. The New Dutch Waterline was dismantled in 1964. In the years following, several sites along the New Dutch Waterline have been repurposed as cultural attractions to share Dutch history with the contemporary public.⁵⁵ (Figure 22)

The contemporary Bunker 599 project was designed by Rietveld Architecture Art Affordances and Atelier de Lyon and completed in 2013. Today, it features a large cleave and a boardwalk to a flooded area. The bunker is open to the public and visible from the nearby highway. It is a recently designated Dutch monument.⁵⁶ The cleave allows light in and opens up the interior to the elements.⁵⁷ Typically bunkers have little to no sensory relationship with the exterior, and the cut inverts that relationship.⁵⁸

Alternatively, in Dunkirk, France, the Anonyme project takes a different approach to bunker adaption. The German Army constructed the bunker, along with many others on the same coast, during WWII. Beginning in March of 2014, anonymous designers covered the bunker in shattered mirror fragments to create "politically minded land art."⁵⁹ (Figure 23)

The designers describe:

55 "Bunker 599 / RAAAF + Atelier Lyon" 25 Jul 2012. ArchDaily. Accessed 14 May 2019.

<<https://www.archdaily.com/256984/bunker-599-rietveld-landscape/>> ISSN 0719-8884

56 Ibid.

57 Observed February 2019

58 Paul Virilio, *Bunker Archeology*, (Princeton Architectural Press, 2012)

59 "About", (Anonyme Project 2014) <https://anonymeuntitled.wixsite.com/blockhaus/about>

The mirror is used here as a plastic language. The defensive structure is forgotten, becomes hidden. But in disappearing it is fully revealed. This second skin brings the shadows into the light. These abandoned structures, stripped of their status, are now like the history that created them, separated from our daily life and memory. It is now of greatest importance to bring to light these forgotten vestiges in a time when once again extremism menaces. I wanted to make a statement against the hardness and hostility of concrete, the fragility of the broken mirror; to change this monument, a witness to the second World War to a monument for our memory. With this new camouflage, the bunker appears and disappears depending on the angle of the viewer and the position of the sun. It becomes a track, an imprint difficult to perceive by reflecting the world, or inversely, while it pulls in and throws out blinding fire, a lighthouse sending out an alarm. At a time in human history where the man looked never so much and got lost in his own reflection, to the point of total closure, the mirror here reflects that which is abandoned: the nature we are in the process of destroying. An immeasurable absurdity, like the thousands of tons of concrete stranded there in the dunes of Flanders. By creating an illusion space, the mirror denounces as even more illusory the real space and our blindness. But this solar monument, this "alternate-space", allows the imagination to penetrate the concrete and demonstrates the possibility of victory by that of the creation on the destruction.⁶⁰

While these case studies are not comprehensive or exhaustive, they begin to suggest a series of possible architectural interventions. The museums, while different, suggest ways to define the relationship between the objects and architecture. In addition, they explore different object-related narratives. The bunkers deal with conflict history and demonstrate various means to contend with the weight and isolation of the bunker typology.

60 Ibid.



Figure 23: Anonyme Project in Dunkirke, France; observed February 2019

OBJECT AND ARCHITECTURE



Figure 24: Fourth Plinth in Trafalgar Square; observed February 2019

OBJECT AND ARCHITECTURE

At the crux of the design thinking is the relation between the architecture and the objects. The architecture is considered to serve as a host environment for the objects. In turn, the objects enrich the architecture.⁶¹ Broadly, objects are understood through context. For this project, context is defined as data adjacent to and related to the object. Context can span a multitude of subjects including historical, archaeological, environmental, architectural, cultural, and political. In the case of looted antiquities, the object's context is stripped.⁶² Arguably, context is a means of storytelling. While the looted antiquities have been stripped of their archaeological, historical, and environmental context, the socio-political context under which they were looted relays an alternate story about the nature of unrest. Hence, in a proposed US Center for Illicit Antiquities, there are design opportunities to create an architecture that addresses the story of looting and conflict and provides a new context.

For this re-contextualization, the architecture is defined as a host. Based on the case studies, there are six methods through which architecture hosts objects: floor, plinth, ornament, wall, ceiling, and environment. Each of these settings displays the object differently and has a privilege, the privileged point is the actor that benefits most from the hosting. In a floor setting, the object is placed directly on the floor. Often, the observer must divert their gaze downward to see the object and the underside of the object is obscured. The object has a direct relationship with the floor and can be considered topographic. This hosting privileges the observer; the observer has perceived power over the object, and the object is vulnerable to the observer. The object is re-contextualized as an extension of the floor.⁶³ In a plinth setting, the object is isolated from its surroundings and elevated to be closer to the visitor's eye. The object has a direct relationship with the plinth and can be considered topographic. This hosting privileges the object and wholly exposes the object. The object is isolated and is, therefore, self-contextualized.⁶⁴ ⁶⁵ In an ornament setting, the object is integrated into architectural flourishing. The object has a direct relationship

61 John Britton, 1771-1857. *The Union of Architecture, Sculpture, And Painting: Exemplified by a Series of Illustrations, With Descriptive Accounts of the House And Galleries of John Soane*, (London: The author, 1827)

62 Auslander, Leora, and Zahra, Tara. *Objects of War : the Material Culture of Conflict and Displacement* Ithaca: Cornell University Press, 2018.

63 An example of floor-set display is Rachel Whiteread's *Embankment* at the Tate Modern Museum

64 It can be argued that the plinth is an extension of the floor and that the object is a topographic extension of the floor.

65 An example of plinth-set display is *Kritios Boy* at the Acropolis Museum

with the architecture. This hosting privileges the architectural host and partially obscures the object depending on the architecture. The object is re-contextualized to relate to the building, and in doing so the object's meaning is directly tied to the architecture.⁶⁶ In a wall setting, the object is placed directly on the wall. The building and the visitor share the privilege.⁶⁷ In a ceiling setting, the object is hung on the ceiling. This type of hosting privileges the architectural host and partially obscures the object. The visitor is below the object.⁶⁸ In an environmental setting, the object is placed adjacent to other objects to create a micro-environment. In this case, the grouping of objects is privileged.⁶⁹ (Figure 25)

Considering these types of architectural hostings provides a palette, for design decisions for the gallery portion. As discussed previously, the initial research yielded four distinct themes regarding the nature of looting: deception, religion, transactions and the global economy, and iconoclasm and cultural cleansing. These themes would inform gallery narratives. Since the collection changes to incorporate new objects and repatriate others, the collection is not curated. Instead, the architecture could be curated to host the objects.

When an object is taken into custody, Immigration and Customs must prove probable cause. In order to prove probable cause, agents have to perform a preliminary investigation. In the course of the investigation, agents could begin to piece together a story about the looted object.

The following questions could be used to gain an understanding of the object's journey:

- Where did this object come from? (Syria, Iraq, Mali?)
- What is its value in the US market?
- Who owned the object previously?
- Is this object linked to other objects or nefarious actors?
- What purpose did it serve? (Architecture, museum object, artifact?)
- Is it broken into parts? On purpose?
- Does the object need special care
- Who looted it?
- What was happening when it was looted?
- Who bought it?
- Can we trace the transaction? Was there trade for goods?
- Is this object linked to others?

In a proposed US Center for Illicit Antiquities, the objects could be sorted according to the gallery themes. Each gallery would have specific architecture that related to these thematic

66 An example of ornamentation-set display is Lamassu at the British Museum

67 An example of wall-set display is the reliefs from the frieze of the parthenon at the British Museum

68 An example of ceiling-set display is the frescoes in the Sistine Chapel

69 An example of environment-set display is the Sackler Wing at the Met



FLOOR



PLINTH



ORNAMENT

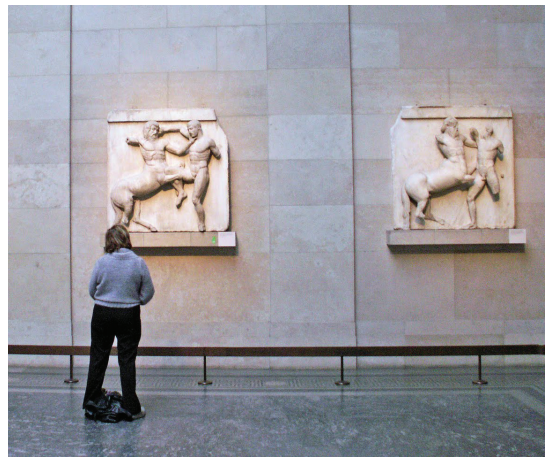

WALL



CEILING



ENVIRONMENT

Figure 25: Architectural hostings

US CENTER FOR ILLICIT ANTIQUITIES



Figure 26: Rendering of central hall with niches for objects

narratives, and these narratives would gain meaning through the objects.

US CENTER FOR ILLICIT ANTIQUITIES

In considering a hypothetical US Center for Illicit Antiquities, it was essential to develop a program (Figure 27), strategies for connecting to existing infrastructure, and design methods for storytelling. The program consists of space to house objects, research and storage space, and support space. These spaces and their associated square footage allotments are speculations from the analysis of case studies and feedback from heritage conservation professionals and government officials.

In this case, the design proposal adapts and adds to the existing bunker in order to become a US Center for Illicit Antiquities. As seen in the site plan, the proposal includes a boardwalk that connects the parking adjacent to the lighthouse to the bunker. (Figure 28) Visitors enter through the original historic entrance and then proceed through to the addition. The addition has the same formal language and materiality as the historic bunker, but the addition is designed to appear sunken into the existing bunker. As such, visitors can discern the existing bunker from the addition by the contrast in ceiling and wall planes. While the addition touches the bunker, the addition does not extend into the bunker. In the new basement, below the addition, is object storage. At the ground floor, the addition serves as the lobby and temporary “white-box” exhibition space. At the second floor, the addition houses a café, offices, a conservation lab, and conference rooms.

The existing bunker houses the four storytelling galleries. In this area, all design moves were subtractive.⁷⁰ The bunker has thick walls and the galleries excavate this mass to create new textures, niches, apertures, and thresholds to communicate the narratives. The objects suitable for display are located within one of four narrative spaces. These spaces are split into themes of deception, religion, transactions, and iconoclasm. Because the project is unbuilt, the concepts are argued and explored through a series of rendered images and drawings that pose what a future US Center for Illicit Antiquities might look like.

70 Excluding plinths, display cases, and glazing

lobby

publicly accessible object storage

transactions and the global economy

the role of religion

perversity, iconoclasm, and incomplete histories

deception and incongruities

private storage

conservation + investigation

loading + processing

(2) conference room

(1) training room

offices

cafeteria

Figure 27: Proposed Program

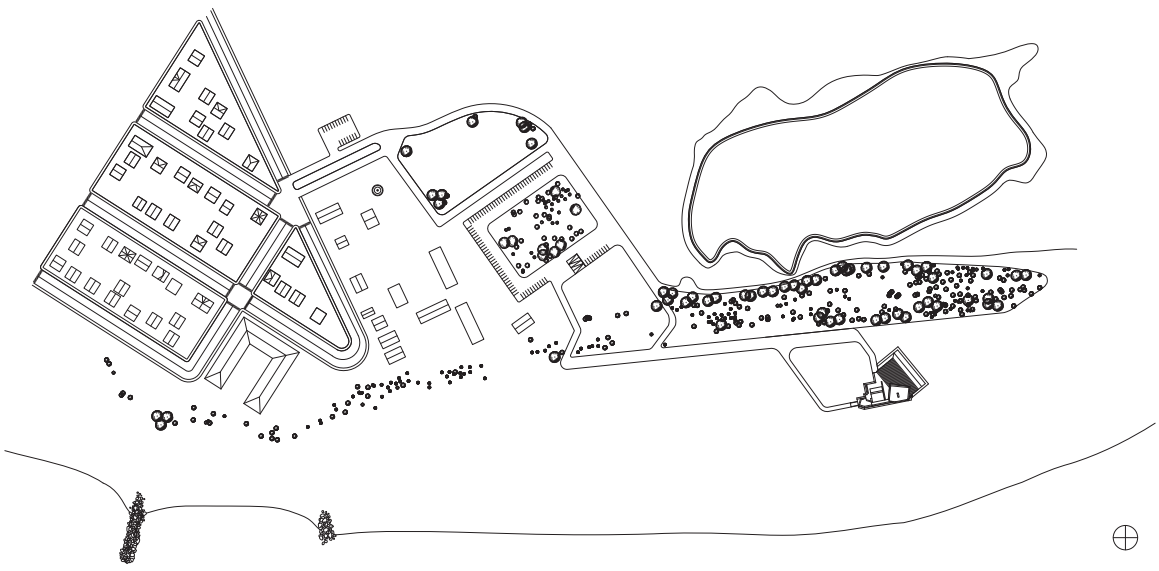

Figure 28: Site plan, not to scale

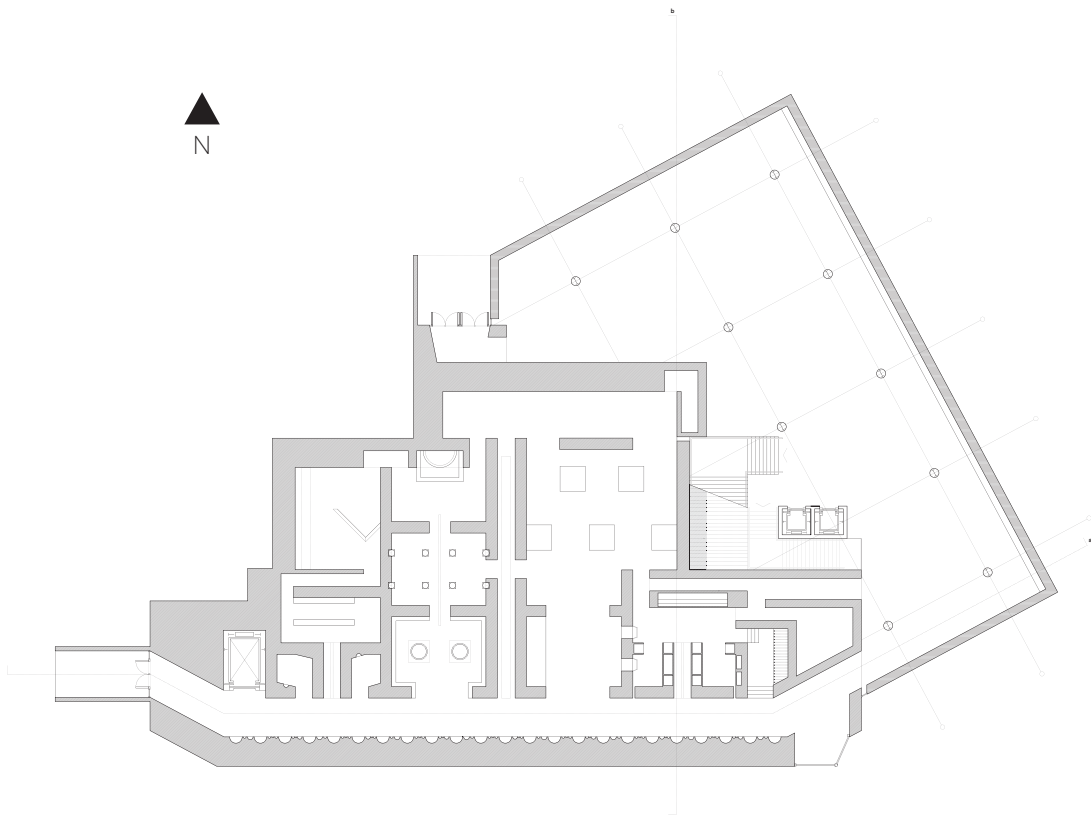

Figure 29: Ground floor plan, not to scale

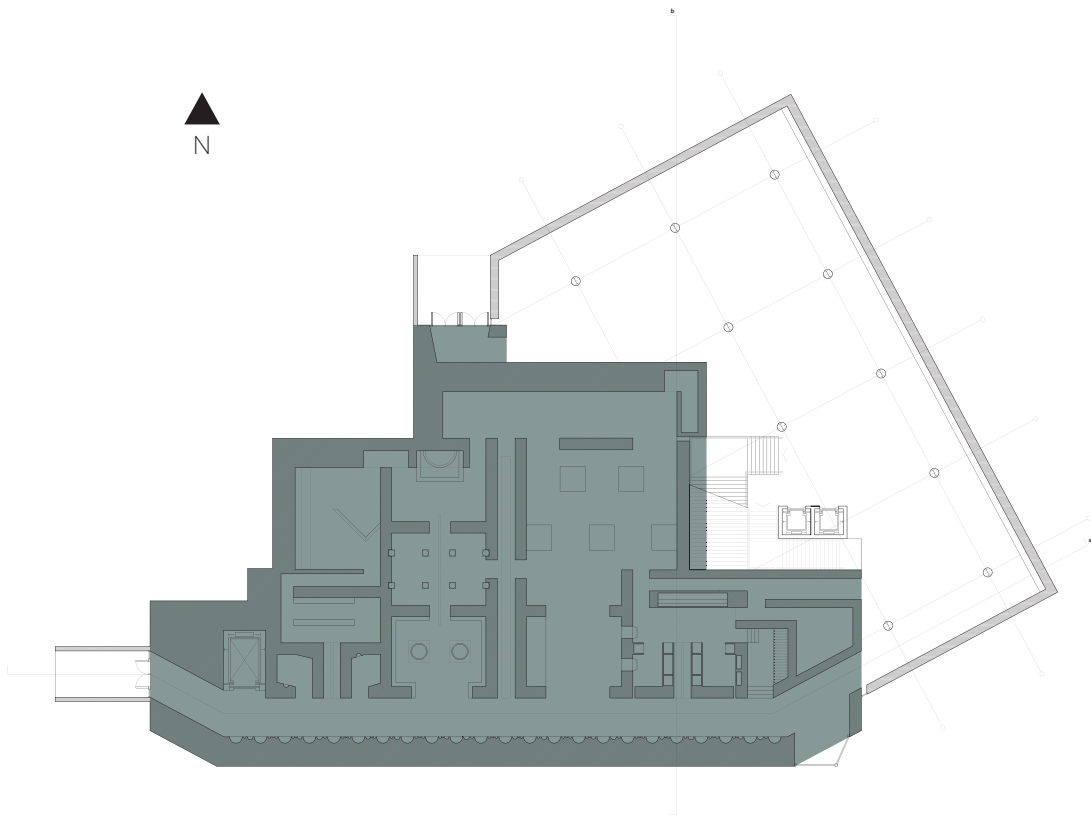

Figure 30: Ground floor plan, existing and proposed, not to scale; footprint of existing bunker highlighted in blue, subtractive alterations have been made within the blue envelope, addition exists outside of the the highlighted area

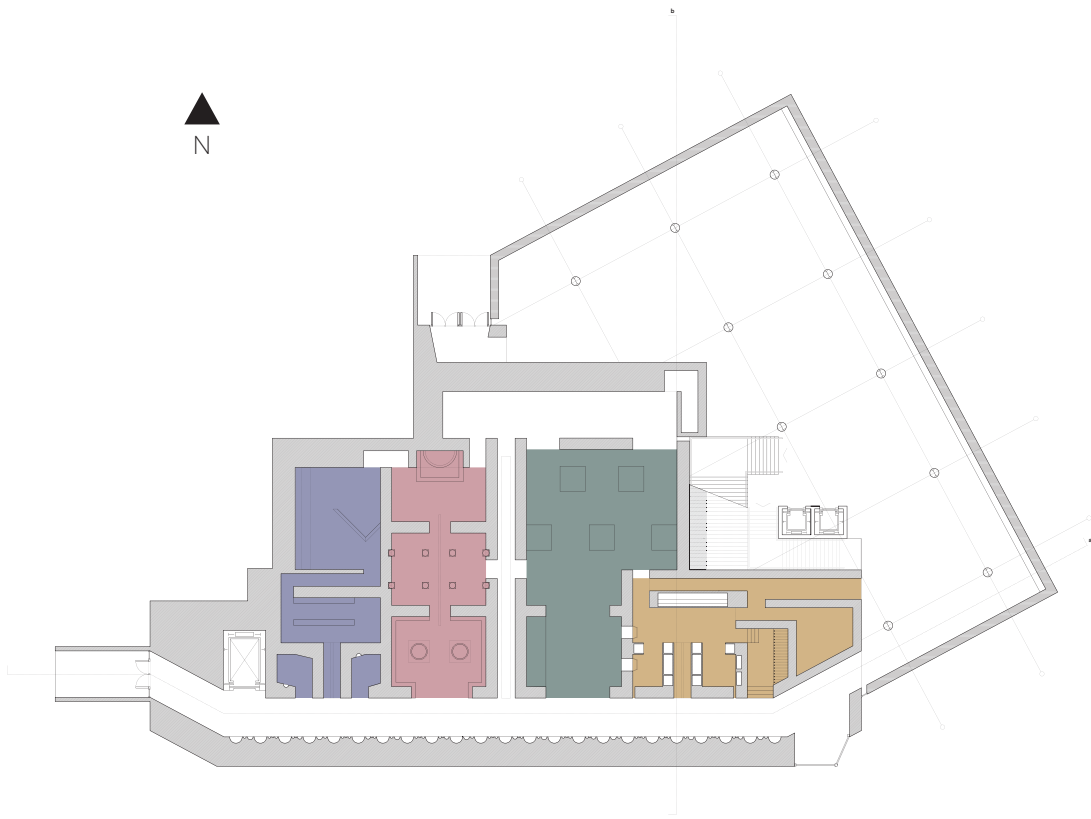

Figure 31: Ground floor plan, galleries in existing bunker (left to right) deception gallery in purple, religion gallery in pink, transactions and the global economy gallery in teal, and iconoclasm and cultural cleansing gallery in yellow not to scale

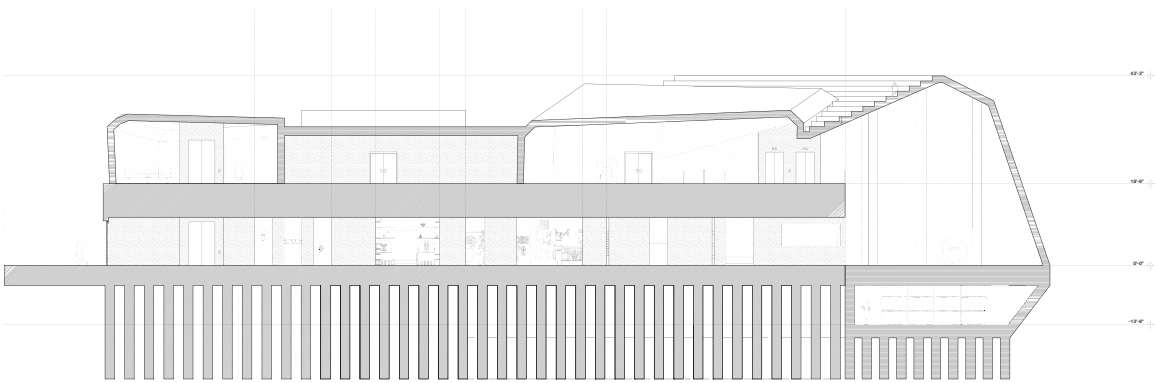

Figure 32: North-facing Section, not to scale

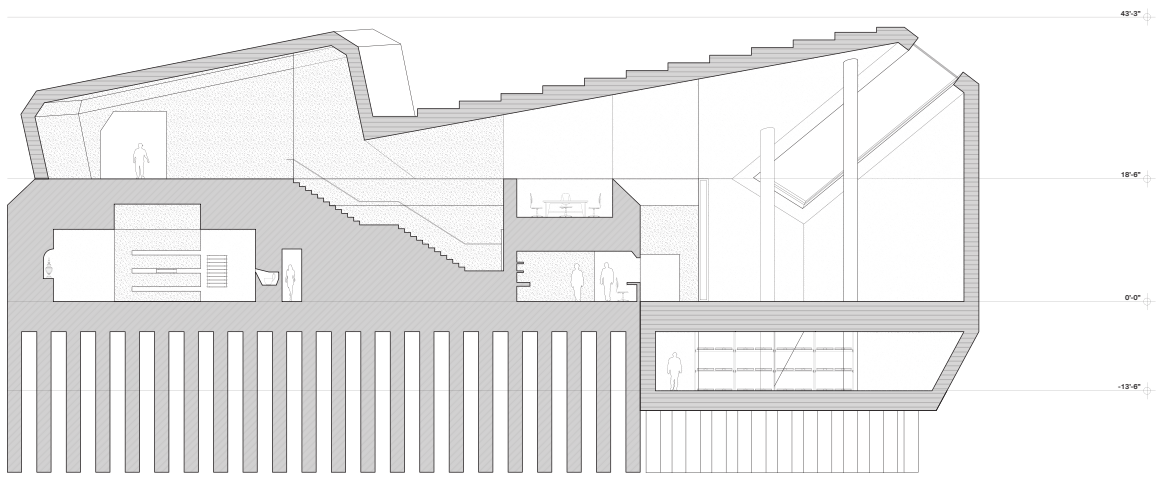

Figure 33: West-facing Section, not to scale

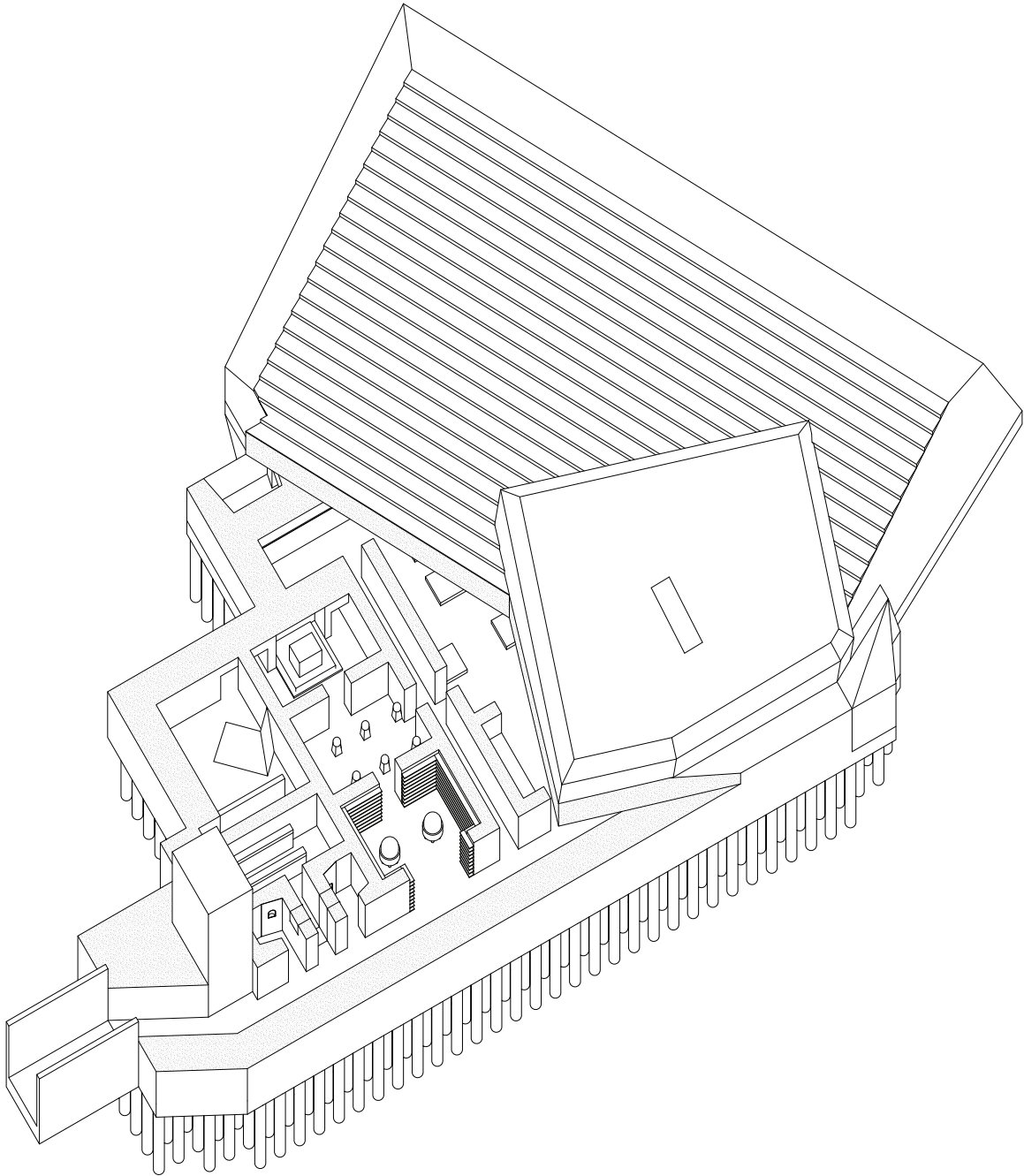

Figure 34: axonometric drawing with ceiling cutaway

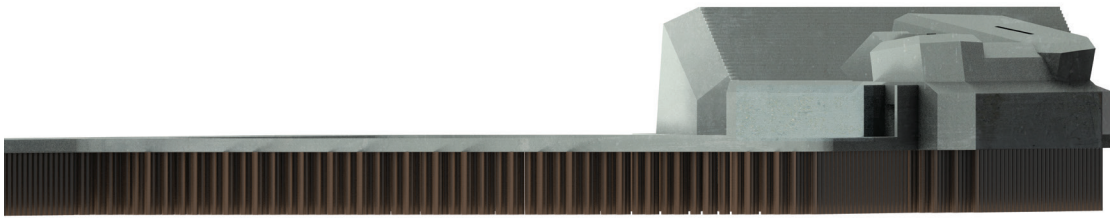

Figure 35: Elevation Rendering

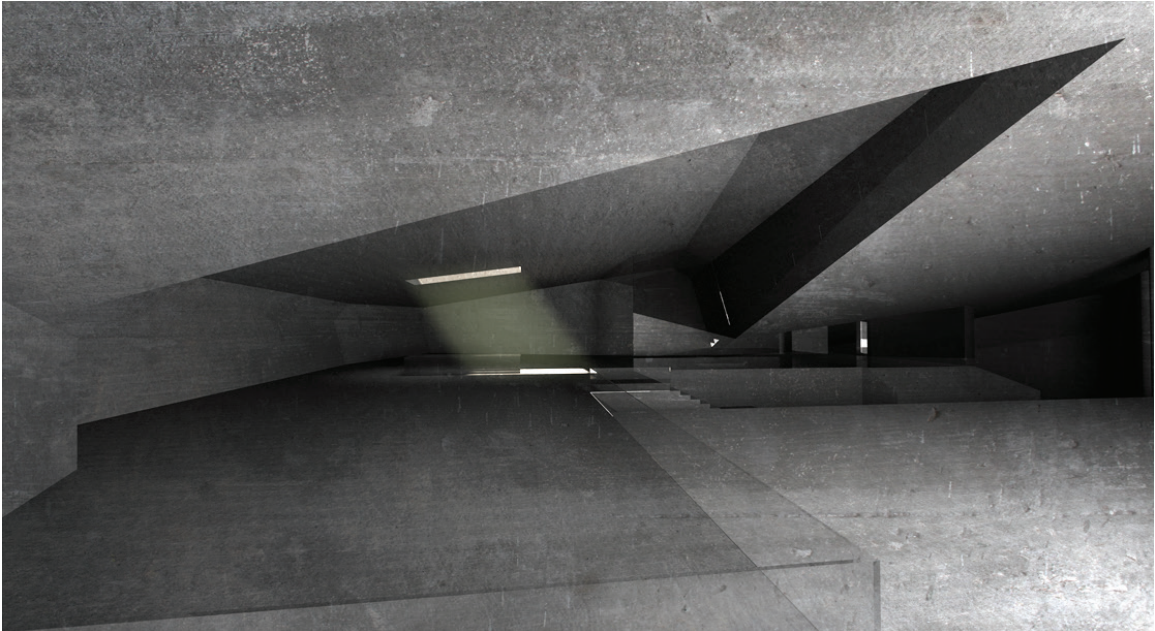

Figure 36: Rendering at the second floor



Figure 37: Rendering at the reception



Figure 38: Rendering of architectural strategies for deception gallery



Figure 39: Rendering of architectural strategies for religion gallery



Figure 40: Rendering of architectural strategies for transactions and the global economy gallery

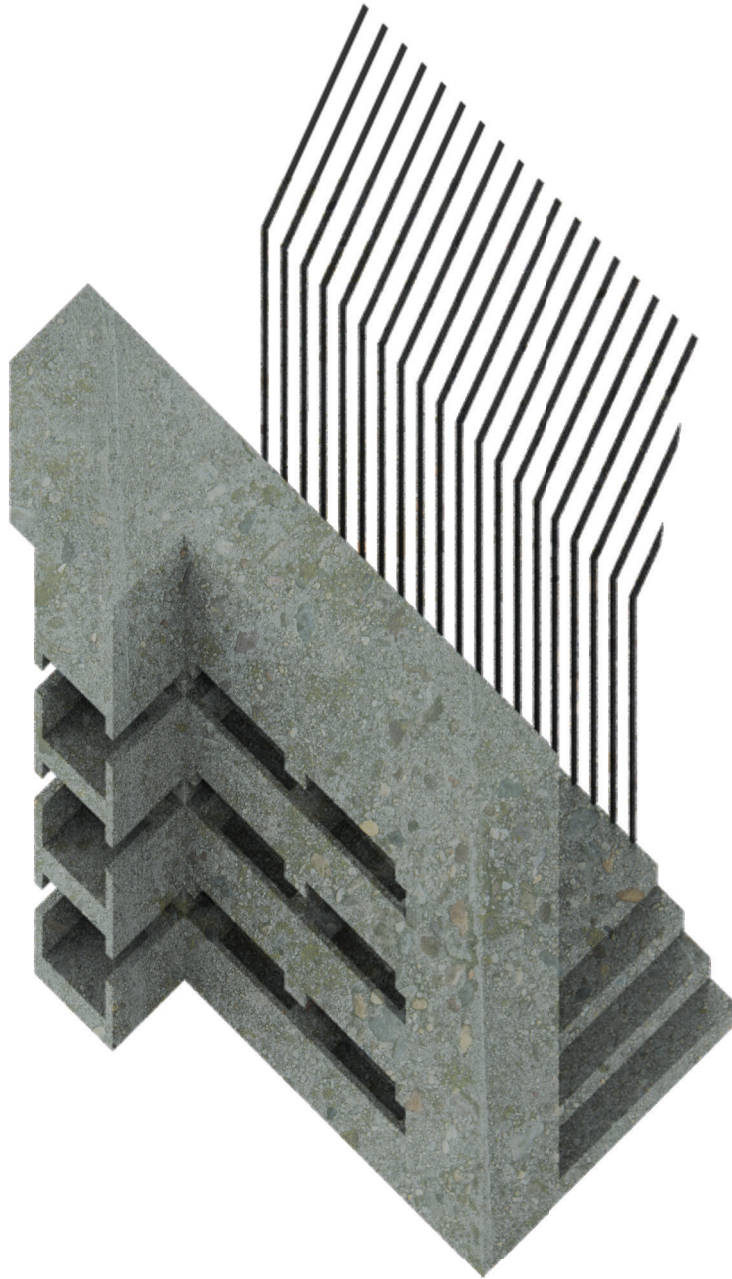

Figure 41: Rendering of architectural strategies for iconoclasm and cultural cleansing gallery

DECEPTION

Often when an object is confiscated, this can be due to a detected deception. In the case of *United States v. Schultz*, Schultz masqueraded Egyptian antiquities as cheap tourist tchotchkes, deceiving officials of the actual value.⁷¹ In a space designed to tell the story of the role of deception in looting, the experience must be disorienting in character. The objects can be obscured, displayed in reflection, or otherwise mis-figured. This effect can be achieved using mirrors, planes of glass, out-of-plane walls, and selective apertures. This effect is employed at the anonyme project bunker in Dunkirke, France. The bunker is covered in mirrors and disappears into the sky or ocean depending on the vantage point despite its mass.⁷² This type of display might posit visitors to consider potential misrepresentation and incongruities in imported antiquities. (Figure 42)

71 Alessandro Chechi, Anne Laure Bandle, Marc-André Renold, "Case Egyptian Archaeological Objects – *United States v. Frederick Schultz*," Platform ArThemis (<http://unige.ch/art-adr>), Art-Law Centre, University of Geneva.

72 Observed February 2019

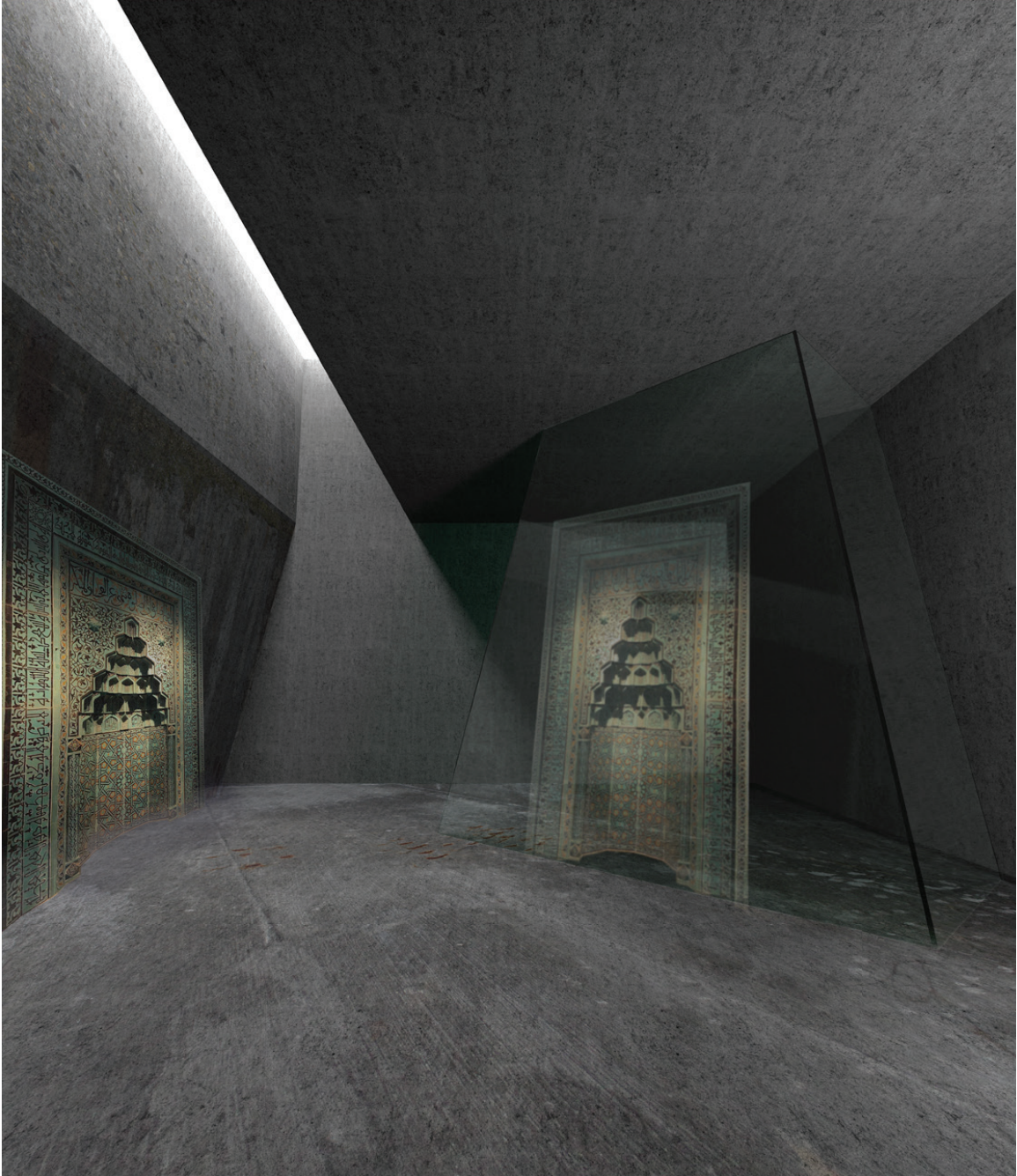

Figure 42: Rendering of the deception gallery

RELIGION

Other times, religion is a motivator of looting. Objects with religious value typically have a higher cultural and monetary value. In the case of Hobby Lobby, the retailer purchased looted goods for a biblical museum.⁷³ Still, in other cases, looters target buddha heads and temples throughout southeast Asia.⁷⁴ The objects are appropriated in their new context as relics. In a space designed to tell the story of the role of religion in looting, the experience must be object-oriented to recall holiness. Like objects at an altar or reliquary, the objects should reside in carefully designed plinths, alone. With light directed toward the object and the object raised on a plinth, the visitor can experience the entire object and the meaning of the object is dramatized. In this proposal, the plinths are modeled after the historic gun pads from the site. This type of display might posit visitors to consider how religious objects have been appropriated and oversold. (Figure 43)

73 Bacon, John. "Hobby Lobby antiquities returned to Iraqi officials." USA Today, May 4, 2018, 06A

74 Mackenzie, Simon and Tess Davis. "Temple Looting in Cambodia Anatomy of a Statue Trafficking Network." British Journal of Criminology 54 (2014)



Figure 43: Rendering of the religion gallery

TRANSACTIONS AND THE GLOBAL ECONOMY

As described above, stable profitability is likely the single most significant factor contributing to looting. Looting is documented as an income generating strategy for crime cartels and terrorist operations.⁷⁵ In a space designed to tell the story of the complexity of the transaction within the context of looting, the experience must be large in scale and relay depth. In this space, the objects are layered in depth to create visual connections and saturate the visitor. This gallery uses floor, wall, and plinth hosting to create a spatial collage. This experience is meant to mirror the strategy used at Sir John Soane's museum in which the various rooms have visually lapped objects.⁷⁶ (Figure 44)

75 Campbell, P. (2013). The Illicit Antiquities Trade as a Transnational Criminal Network: Characterizing and Anticipating Trafficking of Cultural Heritage. *International Journal of Cultural Property*, 20(2), 113-153. doi:10.1017/S0940739113000015

76 Observed February 2019



Figure 44: Rendering of transactions and the global economy gallery

ICONOCLASM AND CULTURAL CLEANSING

In other cases, iconoclasm and cultural cleansing is a motivator for looting and destruction. In the case of the Mosul Museum, ISIS targeted the museum and its collection to seize and display power. ISIS produced a destruction video to connect these objects with cultural cleansing and create an image of their power.⁷⁷ In a space designed to tell the story of the role of iconoclasm in looting, the experience must be perverse. In this space, the objects are completely obscured and can be viewed through apertures and cages. This experience mirrors a peep show; the objects are considered illicit or acknowledged to be perverse. This type of display might posit visitors to feel guilty or recognize the perversity of illicit antiquities. (Figure 45)

⁷⁷ José Antonio González Zarandona, César Albarrán-Torres & Benjamin Isakhan (2018) Digitally Mediated Iconoclasm: the Islamic State and the war on cultural heritage, *International Journal of Heritage Studies*, 24:6, 649-671, DOI: 10.1080/13527258.2017.1413675



Figure 45: Rendering of transactions and the main hallway and iconoclasm and cultural cleansing gallery

CONCLUSION

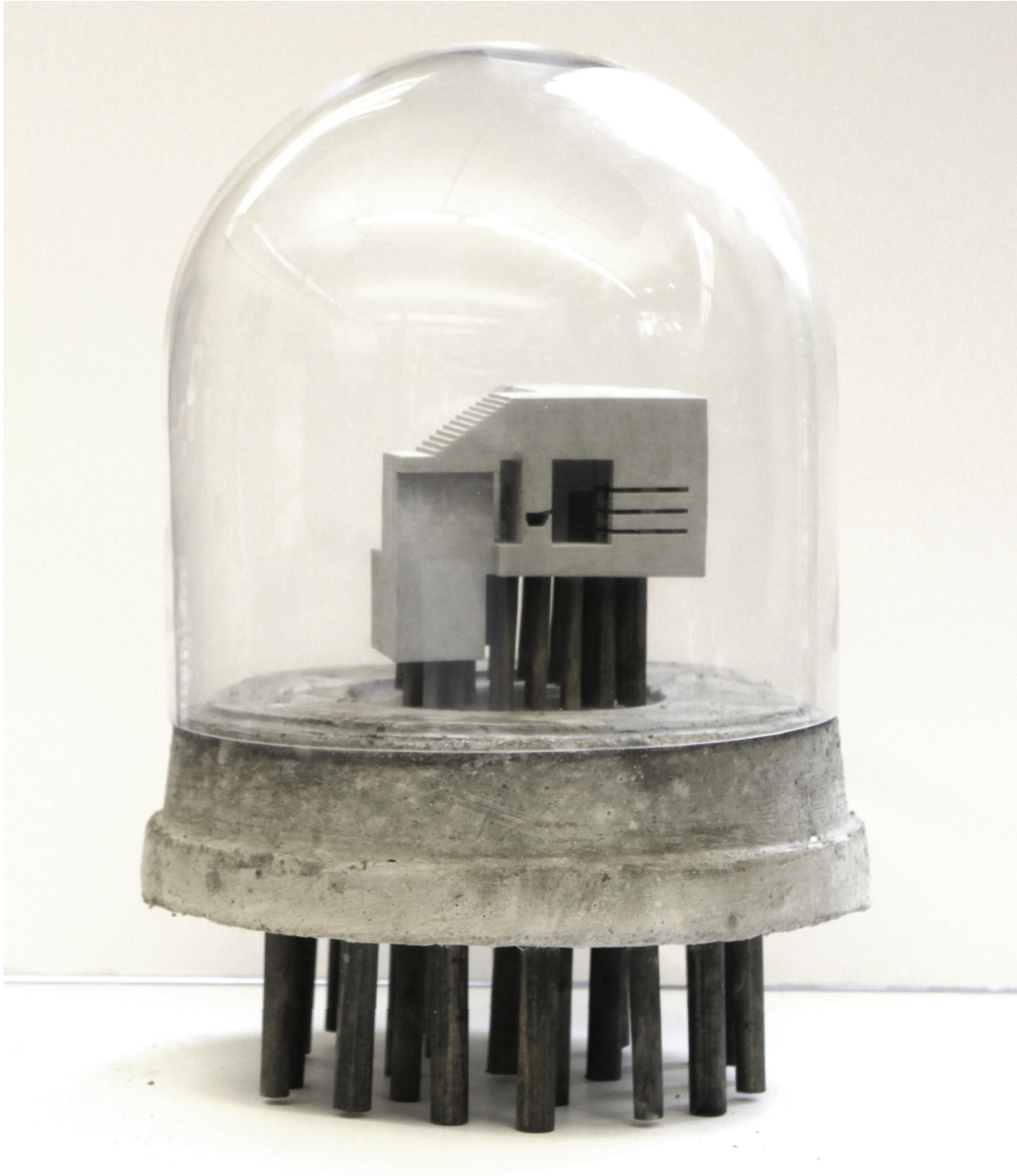

Figure 46: Speculative fragment model

CONCLUSION

After composing the vignettes, I began to think about the types of spaces this produced as fragments and as systems. I crafted a series of models that cut through multiple galleries and bunker spaces. These fragmented "chunks" divorce the galleries from the project and create isolated architectural follies. This frees the chunks to be recontextualized, reconfigured, and reimagined. As I continue to question the relationship between object, architecture, and story, Looking forward, the project raises questions that prompt further exploration. I ask :how does the interpretation change based on context? Could these architectural stories have a life outside of this context, an alternate understanding? Are there other narratives that exist outside of the original characterization? Moreover, how do story-telling moments estrange the design? In endeavouring to understand the relationships between storytelling and architecture, these strategies could and should be tested in alternative proposals. The work for this thesis serves as a starting point and presents an opportunity for further iteration.

In the end, the project questions the bounds of contemporary curation and poses a series of architectural strategies for storytelling. The proposal asserts that architecture is a medium for storytelling. This assertion is tested in an imagined US Center for Illicit Antiquities. In order to justify a spatialized proposal for looted antiquities, the design speculates on an alternative civic infrastructure to enable display, public education, and storage. In both representation and design, the project hopes to provoke discussion on the capacity for architecture to communicate narratives and question spatial interpretation.



Figure 47: Speculative fragment model

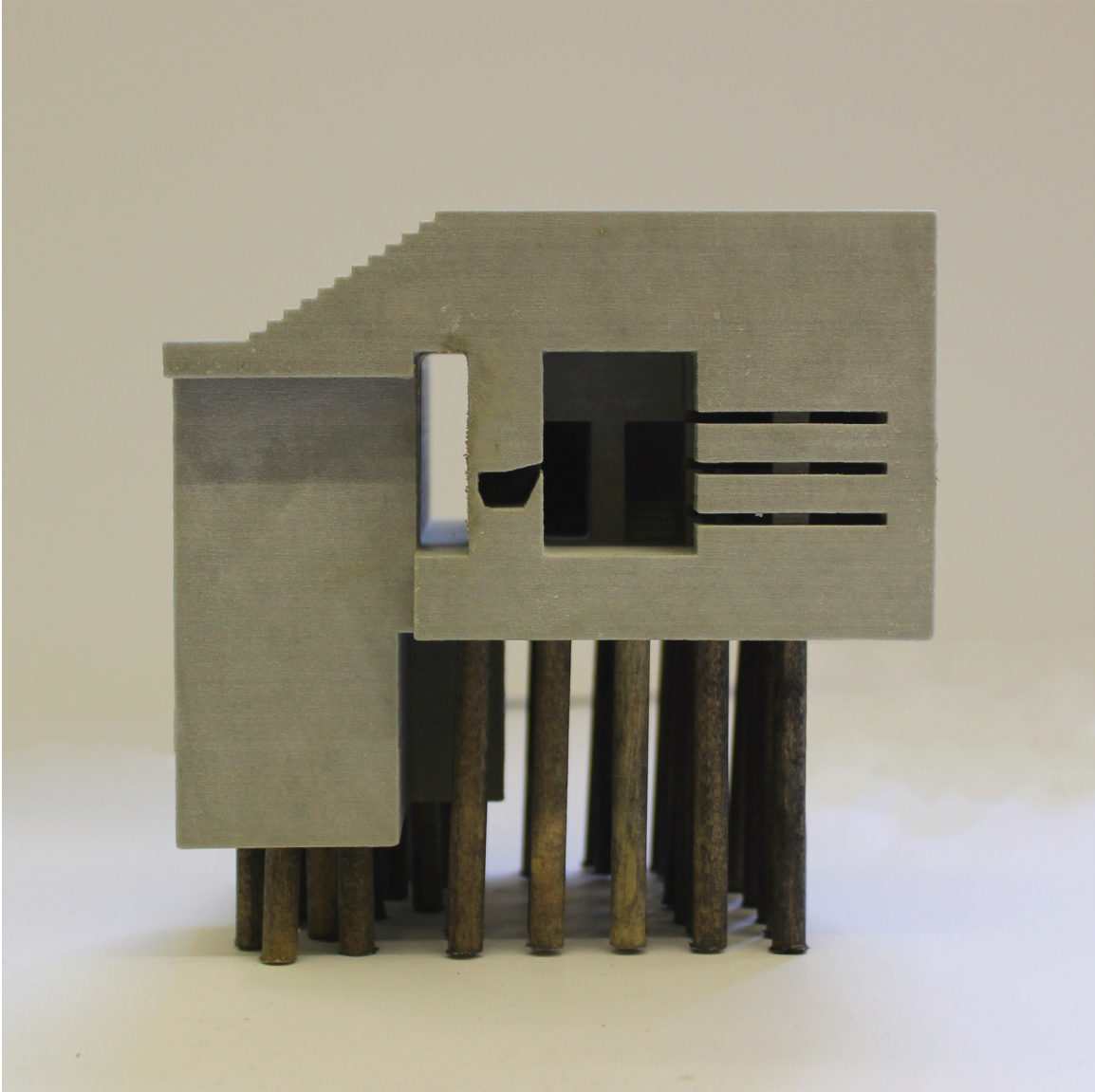

Figure 48: Speculative fragment model



Figure 49: Speculative fragment model

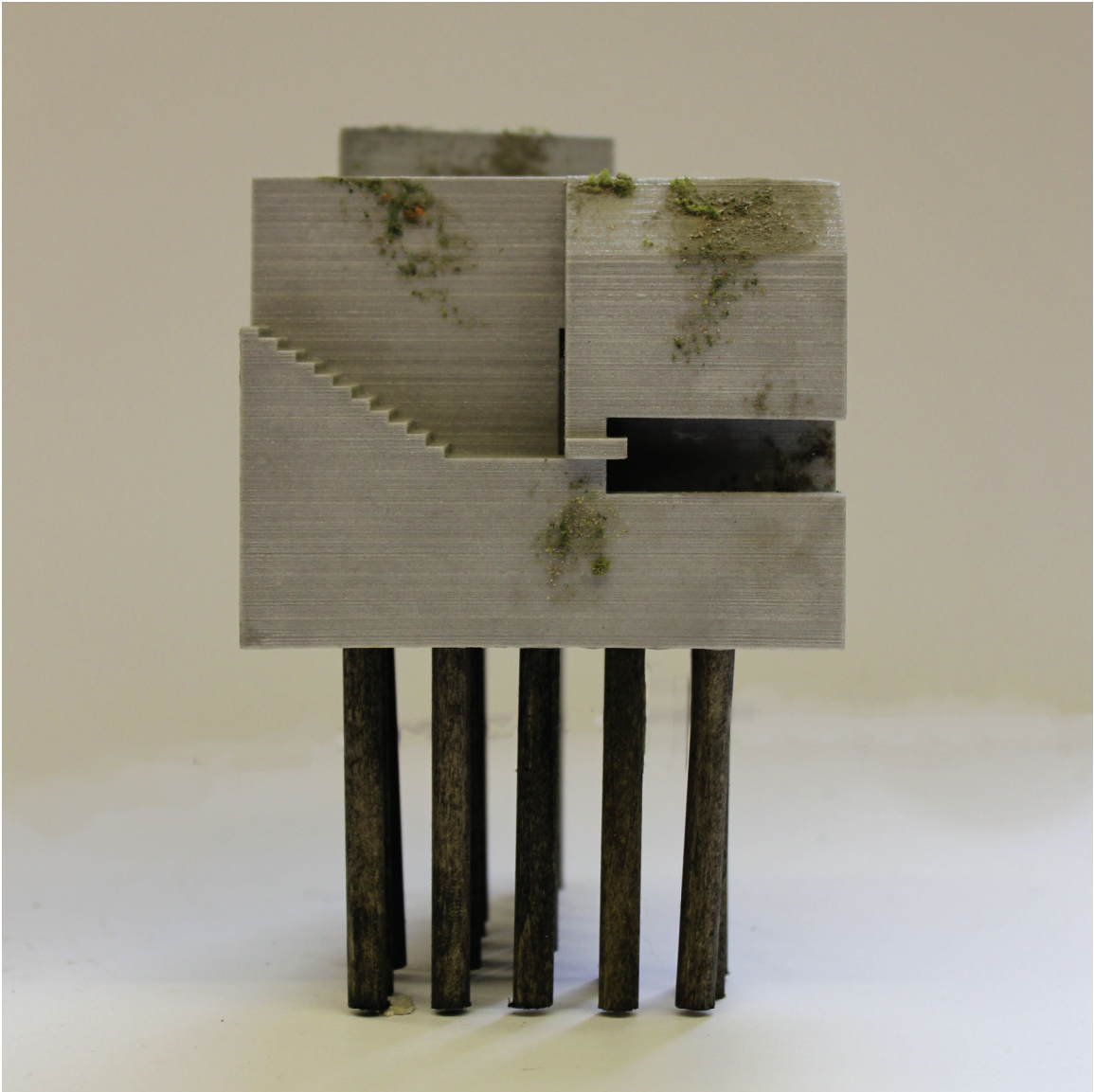

Figure 50: Speculative fragment model

BIBLIOGRAPHY

- A New Description of Sir John Soane's Museum. 9th rev. ed. London, The Trustees, 1991
- "About", (Anonyme Project 2014) <https://anonymeuntitled.wixsite.com/blockhaus/about>
- Alessandro Chechi, Anne Laure Bandle, Marc-André Renold, "Case Egyptian Archaeological Objects – United States v. Frederick Schultz," Platform Artemis (<http://unige.ch/art-adr>), Art-Law Centre, University of Geneva.
- Almqvist, Kurt, and Louise Belfrage. Cultural Heritage At Risk: The Role of Museums In War and Conflict.
- Atwood, Roger. Stealing History : Tomb Raiders, Smugglers, and the Looting of the Ancient World 1st ed. New York: St. Martin's Press, 2004.
- Bacon, John. "Hobby Lobby antiquities returned to Iraqi officials." USA Today, May 4, 2018, 06A
- Beven, Robert. The Destruction of Memory: Architecture at War. Chicago: The University of Chicago Press, 2006
- Bogdanos, Matthew, and William Patrick. Thieves of Baghdad: One Marine's Passion for Ancient Civilizations and the Journey to Recover the World's Greatest Stolen Treasures. 1st U.S. ed. New York, NY: Bloomsbury Pub., 2005.
- Britton, John, 1771-1857. The Union of Architecture, Sculpture, And Painting: Exemplified by a Series of Illustrations, With Descriptive Accounts of the House And Galleries of John Soane, London: The author, 1827
- Brodie, Neil. Archaeology, Cultural Heritage, and the Antiquities Trade Gainesville, FL: University Press of Florida, 2006.
- Brodie, Neil., and Tubb, Kathryn Walker. "Illicit Antiquities : the Theft of Culture and the Extinction of Archaeology " London ;; Routledge, 2002.
- "Bunker 599 / RAAAF + Atelier Lyon" 25 Jul 2012. ArchDaily. Accessed 14 May 2019.
<<https://www.archdaily.com/256984/bunker-599-rietveld-landscape/>> ISSN 0719-8884
- Campbell, P., "The Illicit Antiquities Trade as a Transnational Criminal Network: Characterizing and Anticipating Trafficking of Cultural Heritage" International Journal of Cultural Property, 20(2), 2013 113-153
- Caple, Chris. Objects : Reluctant Witnesses to the Past London ;; Routledge, 2006.
- Charney, Noah. Art and Crime : Exploring the Dark Side of the Art World Santa Barbara, Calif.: Praeger/ABC-CLIO, 2009.
- Clarke, Colleen Margaret, and Eli Jacob Szydlo. Stealing History: Art Theft, Looting, and Other Crimes against Our Cultural Heritage.
- "Cultural Property, Art and Antiquities Investigations." ICE, 11 Sept. 2018, www.ice.gov/features/cpa.

- Cuno, James. *Who Owns Antiquity?: Museums and the Battle Over Our Ancient Heritage*. Princeton: Princeton University Press, 2010.
- Foucault, Michel, and Jay Miskowiec. "Of Other Spaces." *Diacritics* 16, no. 1 (1986): 22-27. doi:10.2307/464648.
- Gage, Mark Foster. "Killing Simplicity: Object-Oriented Philosophy in Architecture." *Log*, no. 33, 2015, pp. 95–106.
- Grinke, Paul. *From Wunderkammer to Museum*. Rev. and expanded ed. London: Quairitch, 2006.
- Gerstenblith, Patty. "Controlling the International Market in Antiquities: Reducing the Harm, Preserving the Past" *Chicago Journal of International Law* 8 (2007): 169-195
- Gerstenblith, Patty "The Destruction of Cultural Heritage: A Crime Against Property or a Crime Against People," *The John Marshall Review of Intellectual Property Law*, no. 15 (2016)
- Hardy, Samuel Andrew. *Illicit Trafficking, Provenance Research, and Due Diligence: the State of Art*. UNESCO 2016
- Hedrick, Casey "State, Territory, and Commonwealth Beach Nourishment Programs A National Overview" (Office of Ocean & Coastal Resource Management, National Ocean Service National Oceanic & Atmospheric Administration, U.S. Department of Commerce, OCRM Program Policy Series Technical Document No. 00-01 March 2000)
- Hinman, E. (n.d.). *Defensive design: Design for security and mitigating potential terrorist attacks. The Routledge companion for architecture design and practice: established and emerging trends* /. New York, NY:: Routledge,. doi:10.4324/9781315775869
- Kreder, Jennifer Anglim, and Jason Nintrup, *Antiquity Meets the Modern Age: eBay's Potential Criminal Liability for Counterfeit and Stolen International Antiquity Sales*, 5 *Case W. Res. J.L. Tech. & Internet* 143 (2014)
- Mackenzie, Simon and Tess Davis. "Temple Looting in Cambodia Anatomy of a Statue Trafficking Network." *British Journal of Criminology* 54 (2014)
- Mancini, J.M., and Keith Bresnahan, eds. *Architecture and Armed Conflict: The Politics of Destruction*. New York: Routledge, 2015. Print.
- Merryman, John Henry, and Albert Edward Elsen. *Law, Ethics, and the Visual Arts*. 4th ed. London: Kluwer Law International, 2002.
- Monteyne, David. *Fallout Shelter: Designing for Civil Defense In the Cold War*. Minneapolis [Minn.]: University of Minnesota Press, 2011
- Moussavi, Farshid. *Function of Ornament*. Actar/birkhauser, 2009.
- Mueller, Tom. "How Tomb Raiders Are Stealing Our History." *National Geographic*, National Geographic, 13 May 2016, www.nationalgeographic.com/magazine/2016/06/looting-ancient-blood-antiquities/.
- National Register of Historic Places, Battery 223, Cape May Point, Cape May County, New Jersey, National Register #1024-0018.

National Stolen Property Act Agencies Et Seq, <https://coast.noaa.gov/data/Documents/OceanLawSearch/Summary%20of%20Law%20-%20Na>

Nicholas, Lynn H. *The Rape of Europa: The Fate of Europe's Treasures In the Third Reich and the Second World War*. New York: Knopf, 1994.

Parcak, Sarah, David Gathings, Chase Childs, Greg Mumford, and Eric Cline. "Satellite Evidence of Archaeological Site Looting in Egypt: 2002–2013." *Antiquity* 90, no. 349 (2016): 188–205. doi:10.15184/aqy.2016.1.

Roehrenbeck, Carol A. (2010) "Repatriation of Cultural Property—Who Owns the Past? An Introduction to Approaches and to Selected Statutory Instruments," *International Journal of Legal Information*: Vol. 38: Iss. 2, Article 11

Rothfield, Lawrence. *Antiquities Under Siege: Cultural Heritage Protection After the Iraq War*. Lanham, MD: AltaMira Press, 2008.

Schwartz, Alan, "Rethinking the Laws of Good Faith Purchase" (2011). Faculty Scholarship Series. 4166. https://digitalcommons.law.yale.edu/fss_papers/4166

Steedman, Marijke, and Grant H. Kester. *Gallery as Community: Art, Education, Politics*. London, Whitechapel Gallery, 2012.

Stone, Peter G., eds. *Cultural Heritage, Ethics and the Military*. Woodbridge, Suffolk: Boydell Press, 2011. Print

Soane John. *Crude Hints Toward an History of My House in Lincoln's Inn Fields*, 2013.

Thompson, Erin L., author. *Possession : the Curious History of Private Collectors from Antiquity to the Present* /. New Haven ; Yale University Press, 2016.

Terrill, W. Andrew. *Antiquities Destruction and Illicit Sales as Sources of Isis Funding and Propaganda*. Strategic Studies Institute and U.S. Army War College Press. April 2017 (17-32)

Turku, Helga. *The Destruction of Cultural Property as a Weapon of War: Isis in Syria and Iraq*.

Van Schaik, Leon. *Meaning in Space: Housing the Visual Arts, or, Architectures for Private Collections*. Kew, Victoria, Lyon Housemuseum, 2011.

Virilio, Paul. *Bunker Archeology*. Princeton Architectural Press, 2012.

Vytuleva, X. "How to Preserve a Bunker 1 × Unknown (2012-)." *Future anterior : journal of historic preservation history, theory and criticism* / 12, no. 2 (2015): 109–115

Wakounig, Marija. *From the Industrial Revolution to World War II in East Central Europe* /. Berlin :: Lit, 2011.

Wilson, David M, *The British Museum: A History* (London: The British Museum Press, 2002)

Zarandona, José Antonio González, César Albarrán-Torres & Benjamin Isakhan (2018) *Digitally Mediated Iconoclasm: the Islamic State and the war on cultural heritage*, *International Journal of Heritage Studies*, 24:6, 649–671, DOI: 10.1080/13527258.2017.1413675

APPENDIX A: REFERENCE PROJECTS + SITES

- Acropolis Museum
 - Bernard Tschumi
 - Athens, Greece
- Anonyme Project
 - Dunkirk, France
- Atlantic Wall Bunkers
 - Dunkirk, France
- Archive of Affinities
 - Andrew Kovaks
- Barnes Museum
 - Todd Williams & Billie Tsien Architects
 - Philadelphia, PA
- British Museum
 - London England
- Bunker 599
 - RAAAF + Atelier de Lyon
 - Muiden, Netherlands
- Cite de
 - Egyptian Museum
 - Cairo, Egypt
- Isabella Stewart Gardner Museum
 - Renzo Piano Building Workshop
 - Boston, MA
- Feuerle Collection
 - John Pawson
 - Berlin, Germany
- Louvre Lens
 - SANAA
 - Lens, France
- Neues Museum
 - Berlin, Germany
 - David Chipperfield Architects
- Penn Museum
 - Philadelphia, PA
- Pergamon Museum
 - Berlin, Germany
- Sir John Soanes Museum
 - London, England
- Svalbard Global Seed Vault
 - Longyearbyen, Norway
- Zeitz MOCAA
 - Heatherwick Studio
 - Cape Town, South Africa

APPENDIX B: PROGRESS WORK

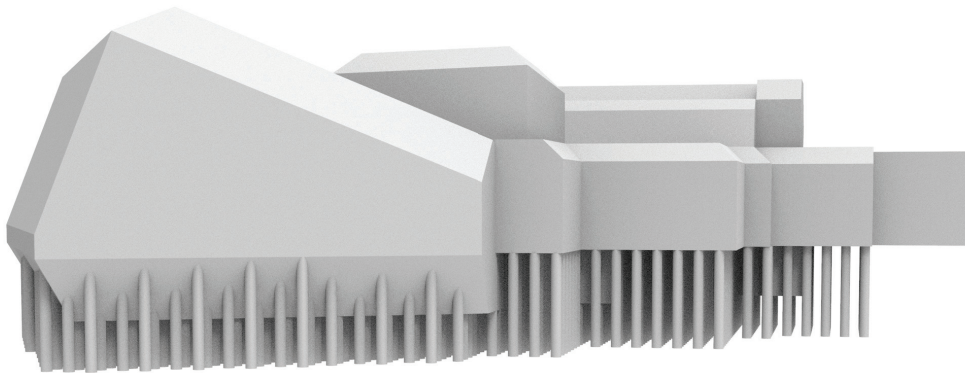
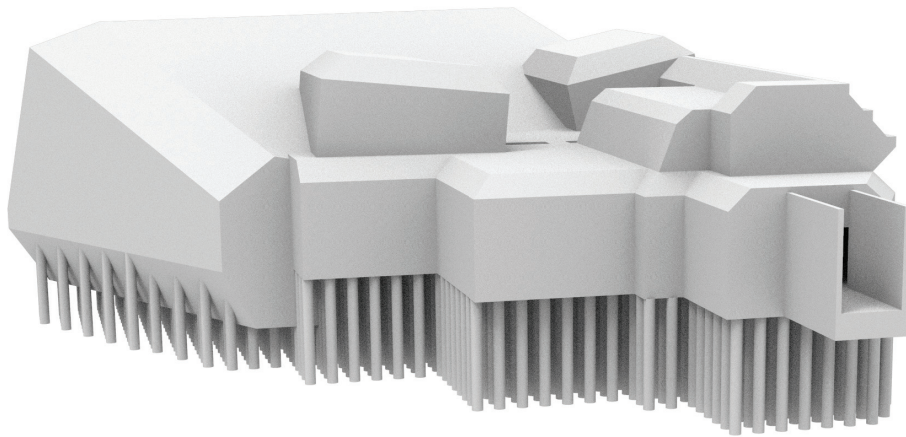
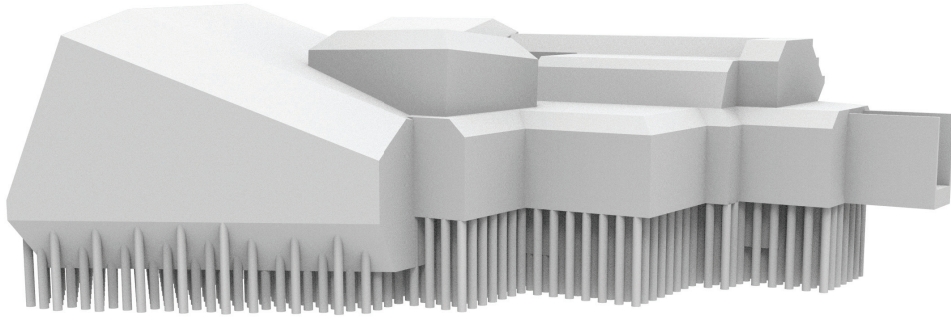

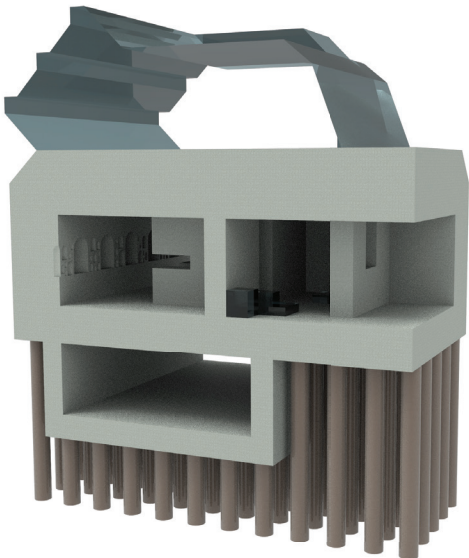
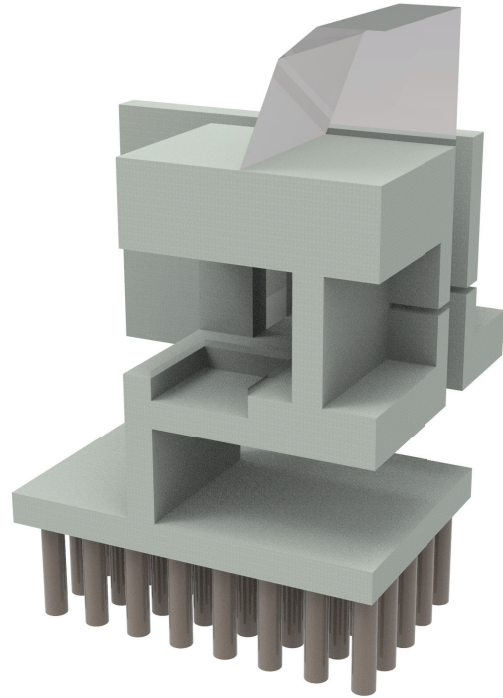
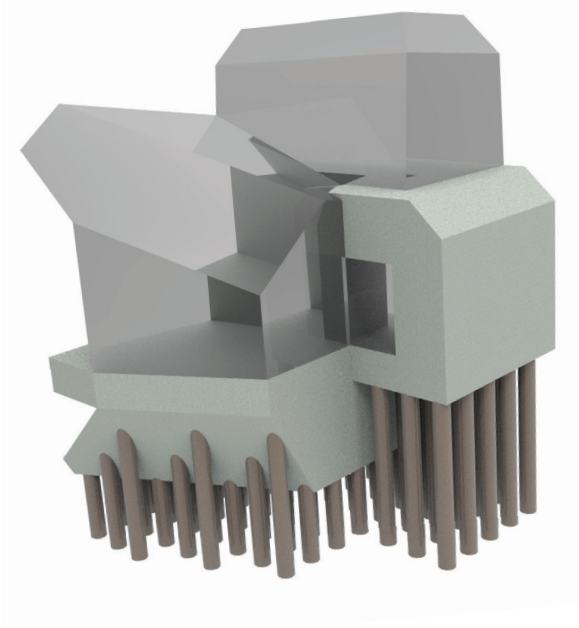

since 1989, the state has added over
33 million cubic yards of sand
to replenish beach erosion



1995



2006



2016

The state has spent over **\$100 million**
on beach replenishment which makes it the largest beach
replenishment program in the country

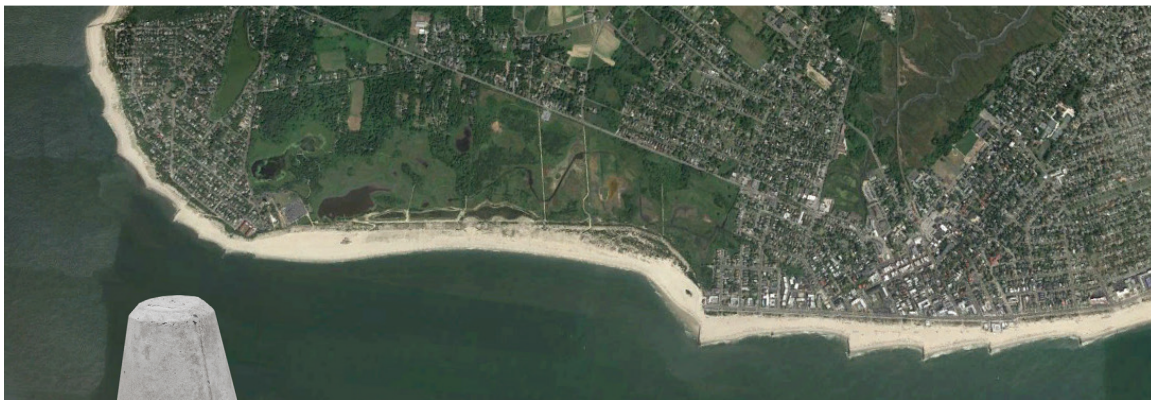

tetrapods
last longer, cost less, and prevent erosion
and wave damage

