

ADAPTED TRAILER HITCHING SYSTEM

FINAL DESIGN REVIEW

PRESENTED BY

Team Hitch

Max Cossalter
mcossalt@calpoly.edu

Joe Hearn
jnhearn@calpoly.edu

Eric Ringsrud
eringsru@calpoly.edu

Max Selna
mmselna@calpoly.edu

Mechanical Engineering Department
California Polytechnic State University

San Luis Obispo

September 2018-June 2019

PREPARED FOR

QL+ Sponsor

Challenger Taylor Morris

Statement of Disclaimer

Since this project is a result of a class assignment, it has been graded and accepted as fulfillment of the course requirements. Acceptance does not imply technical accuracy or reliability. Any use of information in this report is done at the risk of the user. These risks may include catastrophic failure of the device or infringement of patent or copyright laws. California Polytechnic State University at San Luis Obispo and its staff cannot be held liable for any use or misuse of the project.

Table of Contents

Abstract.....	1
1 Introduction	2
2 Background.....	3
2.1 CUSTOMER RESEARCH	3
2.2 PRODUCT RESEARCH	4
2.2.1 Existing Products	4
2.2.2 Existing Patents.....	7
2.2.2.1 Rotating Multiple Ball Trailer Hitch US5560630A [6].....	7
2.2.2.2 Interchangeable Towing Ball Assembly US5085452A [7].....	7
2.2.2.3 Monolithic, double-ball hitch US7125036B2 [8].....	7
2.2.2.4 Motorized directionally steerable trailer tongue jack US677961B1 [9].....	7
2.2.2.5 Folding ball hitch with recessed safety chain attachment US5788258A [10]... 8	
2.2.3 Standards.....	8
2.2.3.1 Trailer Couplings, Hitches, and Safety Chains—Automotive [16].....	8
3 Objectives	9
3.1 Problem statement:.....	9
3.2 Boundary diagram:.....	9
3.3 Customer needs and wants	9
3.4 Quality Function Development	10
3.5 Specification Table.....	10
4 Concept Design.....	12
4.1 Function Decomposition	12
4.2 Ideation.....	12
4.3 Concept Modeling	12
4.3.1 Function: Attaching Safety Chains	12
4.3.2 Function: Inserting Hitch Pin.....	13
4.3.3 Function: One-handed operation of electrical connector weather cover	13
4.3.4 Function: Changing Ball Sizes.....	13
4.3.5 Function: Attaching Safety Chains	15
4.3.6 Additional Concept: “Black Box”	15
4.4 Decision Matrices.....	16
5 Final Design.....	17
5.1 Changing Ball Sizes: “Tri-Ball Rotator” Sub-System	17

5.1.1	Design Justification: Tri Ball Rotator	18
5.1.2	Safety, Maintenance and Repair: Tri Ball Rotator.....	18
5.2	Activating Coupler: “coupler Lever” Sub-System.....	19
5.2.1	Design justification: Tongue lever.....	21
5.2.2	Safety, Maintenance and Repair: Tongue Lever.....	22
5.3	Installing Hitch Pin: “Pin Retainer” Sub-System.....	22
5.3.1	Background Information: Hitch Pins	22
5.3.2	Our final design: Pin Retainer System.....	22
5.3.3	Design Justification: Hitch Pin Retainer.....	24
5.3.4	Safety, Maintenance and Repair: Pin Retainer	25
5.4	Attaching Safety Chains.....	26
5.5	Connecting Trailer Lights: “Electrical Receptacle” Sub-System	26
5.5.1	Design justification: Electrical Receptacle	26
5.5.2	Safety, Maintenance and Repair: Electrical Receptacle	26
5.6	Potential Issues.....	27
6	Manufacturing	28
6.1	Procurement	28
6.2	Manufacturing	28
6.2.1	Electrical Receptacle Manufacturing.....	28
6.2.1.1	Electrical receptacle modifications.....	28
6.2.1.1	Electrical Receptacle Cages.....	28
6.2.1.1	Mounting the Electrical Receptacle Cages	29
6.2.2	Tri-Ball Rotator Manufacturing	29
6.2.2.1	Modifying the Tri-Ball Hitch	29
6.2.2.2	Making the Sliding Block.....	30
6.2.2.3	Adding the Receiver Extension	31
6.2.3	Pin Retainer System Manufacturing	32
6.2.3.1	CNC Machining the Notch Plate, Notch Plate Carrier, and Base Plate	32
6.2.3.2	Making the Pull Handle.....	33
6.2.3.3	Modifying the Receiver to Accept the Pin Retainer System	34
6.2.4	Tongue Lever Manufacturing	35
6.2.5	Tongue Lever Version Two Manufacturing (Tongue Lever B)	38
6.2.5.1	Manufacturing the incline.....	38
6.2.5.2	Manufacturing the tongue lever body.....	38

6.3	Assembly.....	38
6.3.1	Tri-Ball Rotator Assembly.....	38
6.3.2	Pin Retainer System Assembly.....	43
6.3.3	Electrical Receptacle Assembly.....	46
6.3.4	Tongue Lever Assembly.....	47
7	Design Verification.....	51
7.1	Testing.....	51
7.1.1	Timed Test/Oven-Mitt Test	51
7.1.2	Corrosion Resistance Test.....	52
7.1.3	Force Tests	53
7.1.3.1	Force Test Statistical Analysis	55
7.1.3.2	Force Test Conclusions	55
7.1.4	Pinch points.....	55
8	Project Management.....	56
8.1	Design process.....	56
8.1.1	Problem Definition.....	56
8.1.2	Conceptualization	56
8.1.3	Detail Design	56
8.1.4	Manufacturing.....	57
8.1.5	Testing.....	57
8.2	Key activities and milestones.....	58
8.3	Gantt chart with timeline.....	58
9	Conclusion.....	58
9.1	Next Steps	59
10	References.....	60
11	Appendix A: House of Quality	62
12	Appendix B: Gantt Chart	63
13	Appendix C: Design hazards checklist	67
14	Appendix D: Project budget.....	69
15	Appendix E: Decision matrix/Pugh Matrices	72
16	Appendix F: Analyses.....	75
17	Appendix G: Design Verification Plan.....	81
18	Appendix H: FMEA.....	82
19	Appendix I: Risk Assessment	84

20	Appendix J: Operator’s Manual.....	85
20.1	Towing Capacity	85
20.2	Operation of Adapted Hitch Receiver.....	85
20.2.1	Using the custom hitch pin retaining system to remove and install the hitch pin ..	85
20.2.2	Using the modified electrical receptacle.....	87
20.2.3	Using the hitch rotation mechanism	88
20.2.4	Using the trailer coupler actuation lever.....	90
20.2.5	Proper safety chain attachment	92
21	Appendix K: Drawing Package	93

Table of Figures

Figure 1: Association of trailer hardware nomenclature to respective devices.	4
Figure 2: CURT Switch-Ball with J-groove locking mechanism [1]	5
Figure 3: Safety Hitch 2 [2]	5
Figure 4: Tow and Stow Magnum Receiver Hitch Ball Mount [3]	6
Figure 5: ARKSEN© Electric Power Tongue 12v - 3500 LBS, Trailer Camper Jack [4]	6
Figure 6: All States Ag Parts Trailer Hitch Aluma-Tow 3 Ball Hitch [5].....	7
Figure 7: Boundary diagram for project scope [11].....	9
Figure 8: Concept model and concept CAD for modified safety chain hook.....	12
Figure 9: Concept model and concept CAD for receiver with captive hitch pin.....	13
Figure 10: Concept model for electrical connector weather cover.	13
Figure 11: Concept model (a) and CAD (b) for ball changing mechanism.....	14
Figure 12: Concept model for alternative safety chain locking mechanism.....	15
Figure 13: Concept model of the "Black Box"	16
Figure 14: Isometric view of rotating hitch assembly	17
Figure 15: Section view of rotating hitch assembly in towing position (top) and extended for rotation (bottom)	18
Figure 16: Taylor’s Trailer Couplers: (a)without measurements (b) with measurements	19
Figure 17: CAD of the Coupler Lever	20
Figure 18: CAD model views of the Fail-Safe Coupler Lever	21
Figure 19: CAD model views of the pin retainer system.....	23
Figure 20: Detail view of ball detent restraining mechanism	23
Figure 21: Hitch pin retainer component identification.....	24
Figure 22: Hitch Pin Retainer structural prototype in the open (left) and closed (right) configuration	24
Figure 23: Electrical receptacle cage	27
Figure 24: CAD model views of electrical receptacle with cages mounted (left) and an exploded view (right).....	27
Figure 25: Electrical receptacle cage in the vise of the CNC mill.....	28
Figure 26: Mounting the electrical receptacle cages.....	29
Figure 27: Tapped hole in end of Tri-Ball hitch	29
Figure 28: Completed sliding block with shoulder bolt inserted through .501” reamed hole	30
Figure 29: Sliding block with loop welded on to receive cable.....	30
Figure 30: Receiver extension as welded to the OEM Mopar hitch receiver.	31
Figure 31: Receiver extension welded completely on	31
Figure 32: CAM toolpaths for the Notch plat	32
Figure 33: a) CAM operations and b) machining of the notch plate carrier.	33
Figure 34: a) CAM operations and b) machining of the base plate	33
Figure 35: Milling the retaining groove in the end of the pull handle	34
Figure 36: Water Jet Production of the tongue lever flanges.....	35
Figure 37: CAM toolpaths for the tongue lever body	36
Figure 38: Machining of the tongue lever body.....	36
Figure 39: Turning the handle for the tongue lever	36
Figure 40: An example of one of the 3D printers used to make the collar	37
Figure 41: Completed Tri-Ball rotation assembly	38

Figure 42: Shoulder bolt greased and inserted into sliding block.....	39
Figure 43: Applying thread-locker to shoulder bolt threads.....	39
Figure 44: Attaching shoulder bolt and sliding block to Tri-Ball Hitch. Also shown is the crimped cable attached to the correct points.....	40
Figure 45: Eye bolt attachment to hitch receiver and cable length adjustment	40
Figure 46: Proper cable length adjustment results in this maximum Tri-Ball hitch extension.....	41
Figure 47: Proper placement of stopper plates so that Tri-Ball hitch always slides the correct distance into the receiver tube.....	41
Figure 48: Wire wrapped around cable to keep it from moving around.....	42
Figure 49: Components necessary to assemble the pin retainer system.	43
Figure 50: Locating to notch plate within the notch plate carrier.....	44
Figure 51: Properly locating the compression spring to retain the notch plate within the notch plate carrier	44
Figure 52: Installing the pull handle	45
Figure 53: Installing the pin retainer system on the hitch receiver.....	45
Figure 54: Neodymium magnets in the receptacle cage	46
Figure 55:Electrical receptacle with the cage attached.....	46
Figure 55:Flange-Coupler Body Connection.....	47
Figure 55:Crimping the bead with the spring in tension.....	48
Figure 55: Securing the Incline to the Collar.....	49
Figure 55: Securing the Incline to the Collar.....	50
Figure 56: OEM Jeep hitch receiver mounted to receiver test stand.	51
Figure 57: Saltwater residue on hitch pin mechanism, four days after corrosion test	52
Figure 58: Sample photos from the force test.....	54
Figure 59: Pugh matrix for safety chains	72
Figure 60: Pugh Matrix for Coupler Lever	73
Figure 61: Pugh Matrix for Installing Hitch Pin.....	74
Figure 62: Notched hitch pin. Tow Ready #63240.....	85
Figure 63	86
Figure 64	86
Figure 65	89
Figure 66	89
Figure 66	90
Figure 66	91
Figure 66	91
Figure 67	92

Table of Tables

Table 1: Trailer hitch specifications table.....	11
Table 2:Timed hitch up trial data.....	52
Table 3: Force data collected for the various operations in using the system.	53
Table 4: Force test distributions data.....	55
Table 5: Key activities and milestones	58
Table 6: Procurement Information for Adapted Trailer Hitch Confirmation Prototype.....	69

ABSTRACT

This report highlights the entire design process of an adapted trailer hitching system for Taylor Morris: a navy veteran and quadruple amputee. This begins with problem definition through customer and product research. Objectives are generated after the problem is defined and the boundary of the project is set. This outcome of the project focuses on modifications/improvements to the vehicle side of the problem and leaves the trailers untouched. Engineering specifications are developed to constrain the concept design direction, which ultimately dictates the outcome of the final design. The final design is used as a basis to manufacture a structural prototype and ultimately a final (confirmation) prototype of the system. The confirmation prototype is tested to verify the functionality of the design against the previously defined specifications and to identify potential safety issues. The final design meets all pre-determined specifications in the testing phase.

1 INTRODUCTION

Taylor Morris is a veteran explosive ordnance technician who served in the Navy. He was involved in a severe accident in 2012 involving an IED (Improvised Explosive Device). The accident led to quadruple amputations. Taylor uses a prosthetic arm on his right side and prosthetic legs, which have enabled him to be independent despite his physical disability. Taylor enjoys getting out and being active.

Taylor has three trailers which he uses for recreation and work, and tows using a 2014 Jeep Grand Cherokee. Each of his three trailers requires a different tow ball size, which makes the process of switching trailers extremely difficult for him. Team Hitch is a group of senior mechanical engineering students at California Polytechnic State University who designed, manufactured, and tested an adapted trailer hitching system to make the trailer hitching process more effective. The members of Team Hitch are Max Cossalter, Joe Hearn, Eric Ringsrud and Max Selna. The goal for us in this project was to design a system specific to Taylor's needs that will rotate the trailer hitch to the correct ball size, simplify the process of plugging in the trailer wiring harness, improve the trailer coupling process, and improve the process for attaching the trailer and safety chains to the vehicle.

Although initially desired by Taylor, the project did not include any modifications to trailer hardware or vehicle hardware/software since it would not have been possible given the timeframe of this project. A semi-automated system would be better executed in phases by sub-system to allow adequate time to create a reliable solution to the problem.

As a team, we narrowed our scope in the concept design phase of our project and decomposed the problem into five main functions which are detailed in the concept design section. The final design section highlights the physical layout of the final design and includes detail design and analysis of custom parts that make up the final design. The manufacturing section shows the manufacturing operations used to produce the confirmation prototype in detail. Once the device was manufactured, it was tested against the engineering specifications determined in the initial objectives of the project. The confirmation prototype met all of the specifications with satisfactory results.

2 BACKGROUND

2.1 CUSTOMER RESEARCH

Our project is intended specifically for Taylor Morris. We began our investigation of his needs and his ability to interface with our design with the QL+ project description, including the video of Taylor describing the challenges of hooking up a trailer using his prosthetic. We also did internet research including Taylor's TED talk and website. On October 19th we got the opportunity to speak with Taylor on the phone and ask him specific questions about his trailers and the difficulties he encounters interfacing with them.

Taylor uses three hitch-ball sizes (one for each of his three trailers). All the required sizes are attached to his tri-ball-hitch. Installing the hitch and changing between sizes requires lifting and rotating it, which is difficult to do with one prosthetic arm. His arm has a three-finger pinching motion, with an approximate grip strength of 22lbs. Taylor says that objects shaped like the handlebar of a bike are the easiest for him to grip. He has a hard time lifting heavy objects and says that the maximum weight he would be comfortable lifting is 40lbs, though 'the lighter the better' is a good guideline.

Taylor says he also has trouble removing and installing the cotter pins and hitch pin. He described using his prosthetic arm as "like wearing a mitten and a wrist restraint so that you cannot turn or move your wrist." The Arm cannot supinate or pronate (rotate his arm at the elbow), so turning operations are difficult. Taylor can use a tool for adjusting his prosthetics that requires a little twisting, but he does so with his elbow and shoulder.

Once the trailer is resting on the ball, there are several other difficult steps. Taylor says that lifting and closing the tongue lever on the coupler is challenging for him, especially when the lever is corroded. We know from our own experience that this step can be frustrating. Even with two hands, getting an old tongue lever to sit in place requires dexterity, effort and the occasional mallet.

Taylor also asked for something to help him actuate the carabiners on the safety chains, so that he can remove them to from his jeep. Additionally, he wants something to help him hold the weather cover up for the electrical connection on his jeep.

In his video, Taylor mentions that he has trouble turning the crank for the trailer jack, but he recognizes that automatic trailer jacks already exist as a product. On the phone, he said that his current way to hook up a trailer is to use the variable ride height on his 2014 Jeep Grand Cherokee to get the ball in the socket, but this only works if he stages the trailer correctly when it is parked. It would be ideal if he could hook up to any trailer, regardless how it was staged. Additionally, Taylor wants to be able to hook up a trailer without exiting his vehicle. A fully automated trailer hitching process would be ideal. However, we have decided that a fully automated system is outside of the scope for this project and would not be feasible in our timeframe.

Figure 1 below identifies common components of a trailer hitching system that we refer to in this document.

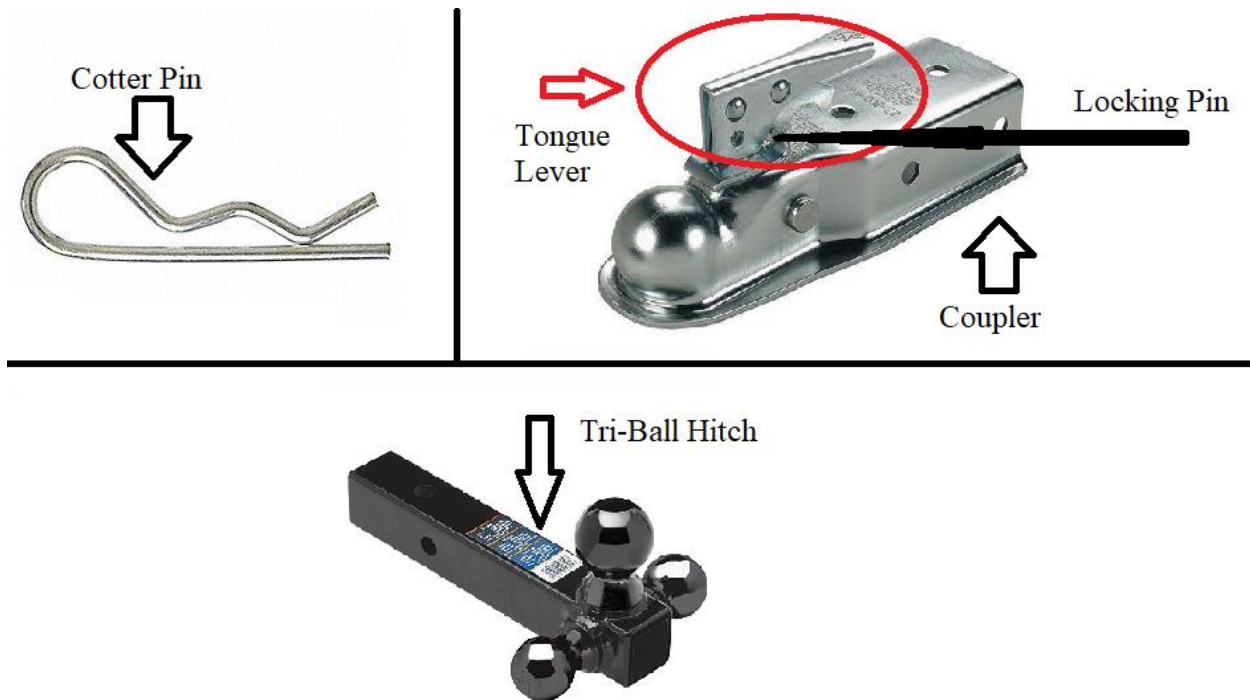


Figure 1: Association of trailer hardware nomenclature to respective devices.

2.2 PRODUCT RESEARCH

2.2.1 Existing Products

To better understand the problem, we investigated products currently on the market aimed at solving similar problems. Thinking of how some of these products would work in our situation (with a prosthetic arm), some of these are more applicable than others. We used the best attributes of each product to create targets that our product should eventually satisfy. Our research found many products that solve one or possibly two of our problem tasks but none of them integrate a solution to all the problems into a single product.

One of the first products encountered during research was the CURT Switch-Ball [1]. This eliminates the need to remove the hitch to change ball sizes. Different sized balls can be removed and attached to the same shank. Balls are removed by twisting and lifting on them. We like how the balls can be switched without needing tools or pins, but we are concerned with the dexterity required to detach and attach the balls. There have also been reports from customers who have gotten the ball stuck on the shank.



Figure 2: CURT Switch-Ball with J-groove locking mechanism [1]

Another product that simplifies the trailer hitching process is the SafetyHitch 2 [2], shown in Figure 3. This product modifies the tongue of the trailer by attaching a small winch and replacing the ball catch mechanism. Trailers are hooked up to the car by attaching the winch cable to the bottom of the ball shank. Then the winch pulls the trailer towards the car until the latching mechanism hits the ball and encloses it securely. This product is effective because it eliminates the need to back up in line with the trailer, lower the tongue on the ball, and secure the latch on the ball. All the user has to do is press a button on a remote to start and stop the winch. The downside to this system is that it is all installed on the trailer. Taylor frequently uses three trailers, so it is not feasible for us to install a system like this on all of them. We need a more integrated solution that installs on the car and hitch receiver rather than the trailer tongue.



Figure 3: Safety Hitch 2 [2]

A product that we thought was interesting was the Tow and Stow receiver [3] shown in Figure 4. This product allows the balls to be switched without removing the hitch from the receiver. With the removal of what looks like a spring pin the balls can be easily rotated on the hitch. This is a good design, but it would need to be modified for Taylor because one of the things he struggles with is the pins. This product also requires two hands to operate effectively.



Figure 4: Tow and Stow Magnum Receiver Hitch Ball Mount [3]

The Ultra-Tow 12 Volt Swivel Electric Trailer Jack [4] can raise or lower a trailer with the push of a button. It runs off the car battery and its 1,500lb tongue weight capacity is greater than that rated for a class IV trailer hitch. It costs just \$130 at northerntool.com and it is just one of many automatic tongue jacks available online. If we were to include a specially built tongue jack in our scope of work, it could easily result in a product that is less refined and more expensive. Furthermore, designing one would take up time and energy that could be used to design solutions to Taylor's other trailer hitch needs. In the QL+ video provided, Taylor acknowledges that this is a solution that is already available. We have decided to exclude the tongue jack from our scope of work.



Figure 5: ARKSEN© Electric Power Tongue 12v - 3500 LBS, Trailer Camper Jack [4]

The All States Ag Parts Hitch [5] in Figure 6 was very interesting because it has the height adjustable pin stack and the totally separate balls that you seem to just place in the slot with no locking mechanism. This is a different approach than the other products because there is no rotational aspect to this design, instead you just pick up and drop in the correct balls. It would be interesting to see if Taylor has the level of accuracy to drop the balls into the slot and remove them efficiently.



Figure 6: All States Ag Parts Trailer Hitch Aluma-Tow 3 Ball Hitch [5]

2.2.2 Existing Patents

The following patents are used to help identify existing solutions to parts of our problem statement.

2.2.2.1 Rotating Multiple Ball Trailer Hitch US5560630A [6]

This patent is for a receiver-mounted trailer hitch fitted with a turntable containing two towing ball sizes. The turntable rotates about a pivot bolt and is secured from rotating using a pin and spring clip. The patent could serve to solve the part of our problem involving changing between ball sizes. This design only has the capability to change between two balls, however.

2.2.2.2 Interchangeable Towing Ball Assembly US5085452A [7]

The interchangeable tow ball assembly is a different concept where the top portion of the ball is a bolt and to change the size of the ball you simply unbolt the ball assembly and change the diameter of the towing ball. This concept has some aspects that make it very easy to use and some features that would make it inconvenient for our purposes. It is a good reference for brainstorming though.

2.2.2.3 Monolithic, double-ball hitch US7125036B2 [8]

The monolithic, double ball hitch may consist of more than 2 trailer hitch balls, extending in distinct directions around a center stem rotating within a monolith. The stem is prevented from rotating using a pin and clip.

2.2.2.4 Motorized directionally steerable trailer tongue jack US677961B1 [9]

A trailer tongue jack that can be steered and driven using a controller. The device uses a motorized acme-threaded rod for height adjustment. It uses a ring-and-pinion system for steering. This device could serve useful for positioning the trailer above the towing ball. Most importantly, it would simplify the current process Taylor uses to lower the trailer on to the ball.

2.2.2.5 Folding ball hitch with recessed safety chain attachment US5788258A [10]

A trailer hitch with a folding ball and safety chain latching mechanism. This patent is relevant to our project mainly for the safety chain latching mechanism, as that could be integrated into a potential solution to improve the simplicity of unlatching the safety chains from Taylor's vehicle.

2.2.3 Standards

We have performed research into SAE standards for everything relating to the loads that each component is required to bear and the proper safety requirements.

2.2.3.1 Trailer Couplings, Hitches, and Safety Chains—Automotive [16]

This document holds all the SAE standards required for the load bearing requirements of the various components of the hitch and receiver system as well as specifications for safety chains and the various pins that could be used. It also specifies the testing requirements for new products of each type.

3 OBJECTIVES

3.1 PROBLEM STATEMENT:

To become more independent, Taylor Morris, who has one prosthetic arm and limited fine motor skills with his prosthetic hand, would like to have a minimally interactive and easier way to connect and disconnect trailers from his vehicle. The tri-ball hitch he uses is too heavy to lift with one hand, and Taylor currently needs the help of another person to switch ball sizes. The trailer safety chains are easy to put on but difficult to take off, and there is not a good way to lower the trailer on to the tow ball. Right now, the process involves using the vehicle air suspension to lift the trailer off the tongue jack, and then folding the tongue jack out of the way. Finally, Taylor has trouble connecting the wiring harness for the trailer lights due to a spring-loaded weather cover on the vehicle.

3.2 BOUNDARY DIAGRAM:

We have decided to limit our boundary diagram [11] to the receiver, the hitch, the safety chains and the electrical plugs. We decided to not include the tongue jack because there are electric ones available on the market that can be purchased and installed. We decided to not include any modifications to the trailer or the car for the sake of time and inaccessibility. We decided to limit our boundaries to these because they encapsulate the steps of the hitching process which are currently the most difficult for Taylor. Figure 7 below shows the drawing.

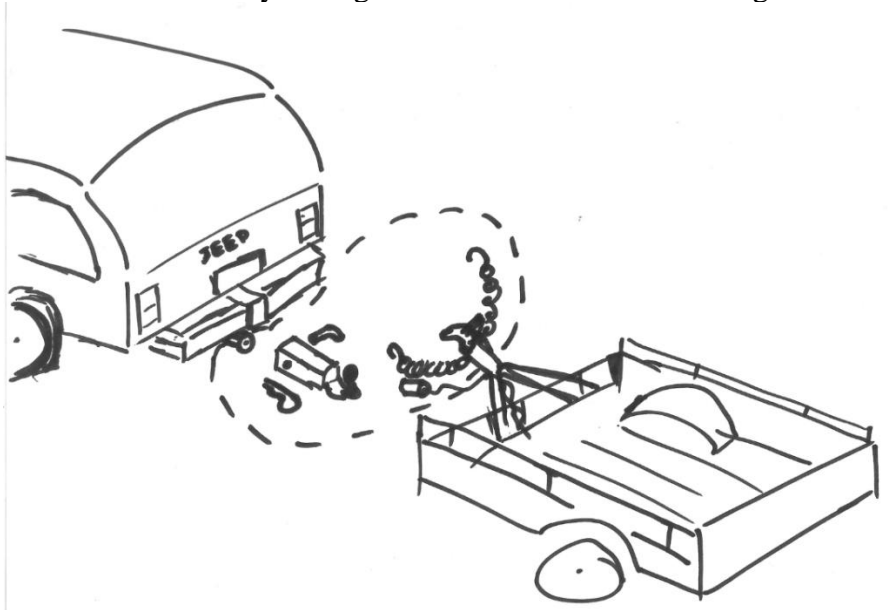


Figure 7: Boundary diagram for project scope [11]

3.3 CUSTOMER NEEDS AND WANTS

Taylor Morris is the end user for the trailer hitching system we will develop. Consequently, he is the primary customer to be considered. The needs and wants we obtained from Taylor are as follows:

- Simplify the trailer hitching process

- Rotate the tri ball without the help of another person, and without dexterous motion.
 - The cotter pin is difficult to remove and reinstall and is easily lost in the trailer hitching process.
- Improve the way the tongue lock is actuated.
 - Taylor currently uses a rock to latch it and struggles to unlatch it.
 - There is a small cotter pin on the tongue lock that is difficult for him to manage.
- Improve the tongue lowering process.
 - This currently involves using the vehicle air suspension to lift the tongue off the tongue jack, and then folding the tongue jack out of the way. The air suspension is then lowered again to bring the trailer back to leveled height.
- Make the wiring harness plug-in process only require one hand.
 - The process currently involves holding the spring-loaded weatherproof latch open with one hand and plugging the harness in with the other.
- Make the safety chain hook-up process only require one hand.
 - The process currently requires two hands to unlatch the carabineers to remove the chains.
- If feasible within the timeframe, make the trailer hitching process automated and remotely controlled from within the vehicle.

3.4 QUALITY FUNCTION DEVELOPMENT

The quality function development (QFD) process revolves around finding appropriate engineering specifications to meet with Taylor's needs. The process of assembling the QFD takes into account the biggest needs for the project as well as the users less important wants for the project. It then allows us to see these things that are absolutely necessary along with the things that may be less important. The critical specifications that we want to include in the QFD have to do with lifting weight and wrist movements. It is important that Taylor does not need to pick up more than 25 pounds and that he does not need to use any complex wrist movements with his prosthetic. There are some specifications that we added to the house of quality that we thought would be beneficial to the overall project but are not necessarily crucial. These include the cost and maintaining the current color scheme. Refer to Appendix A: House of Quality in order to see what we have come up with.

3.5 SPECIFICATION TABLE

Table 1 outlines the required specifications of our finished product based on the QFD analysis. For our project to be successful these specifications must be met. Each need from the QFD has transformed into a specification we can measure. Required strength is the maximum force required by the user when using the hitch system to hook up the trailer.

Table 1: Trailer hitch specifications table

Spec. #	Parameter Description	Requirement or Target	Tolerance	Risk	Compliance
1	Force required by user	25 lbf	max	M	T, A
2	Trailer Attachment Time	10 min	max	L	T
3	Weather Resistant	Corrosion Resistant materials and coatings	N/A	L	I
4	Simple Use/Accessible	Little Dexterity Req	N/A	M	T
5	Safe to Use	No pinch points	N/A	M	I

Since Taylor only has the use of one prosthetic arm, the force required to operate the hitch must be kept low. To test this target, we can attach a spring scale to any levers or buttons that need to be pressed. The risk for this specification is labeled as M, meaning there is a medium risk we miss this goal. In the compliance column, T and A mean we can use tests and analysis to determine if the goal is met. Other goals can be evaluated by inspection (I) and by looking at similar existing products (S). For durability, we want our product to last about 5 years. This can be evaluated with tests, analyses, and by looking at similarities to existing designs. This goal is high risk because it is hard for the first release of a product to be without flaws. We also do not have enough time after construction of the product to complete enough tests to guarantee a long life. Another high-risk goal is the affordability of the product. Since it is a one-off design, parts could be expensive from not buying in bulk. Our first priority is making the product work for Taylor. It is not important to us whether it is affordable to other people who want the product for themselves. Another important specification is that the product must withstand all types of weather. Since it spends most of its life on the roads in Iowa it must resist corrosion from water and salt.

4 CONCEPT DESIGN

4.1 FUNCTION DECOMPOSITION

Our creative design process was done in phases. We began by decomposing our scope into its key functions. The main functions of the project include rotating the triple-ball hitch, implementing a new hitch pinning system to eliminate the cotter pin, and making it easier to attach the safety chains, to hook up the electrical connector, and to lock the tongue latch. We eventually determined that secondary functions, like helping to position the trailer, were less important. Many of these were included in the function decomposition phase and carried through the ideation phase but were not explored further once deemed unimportant.

4.2 IDEATION

Once the functions were defined, we were ready to brainstorm. In the ideation phase we used a variety of methods to come up with many potential ways to solve our functions. These brainstorming methods were crucial in developing a variety of solutions to each problem function. Exercises included “7-Ways”, in which we all came up with seven unique solutions to accomplish a function. Brain Writing was also used, in which we all came up with a couple ideas and then passed our notebooks around so that we could add to, or modify each other's ideas, and the S.C.A.M.P.E.R. method. The S.C.A.M.P.E.R. method involves substituting, combining and rearranging different ideas together to stimulate the creation of new solutions.

4.3 CONCEPT MODELING

Of the dozens of ideas generated in ideation, about twenty were modeled in the concept modeling phase. In this phase, we used simple arts and crafts supplies such as cardboard, tape, toothpicks, corks and LEGO® to build basic models of our most developed ideas. The goal was to build on the ideas we had already generated; the concept modeling phase served an important role in idea generation. Once physical models were built, solutions that were not obvious on paper became apparent. We were also able to find problems with concepts that we thought were viable by building simple models.

4.3.1 Function: Attaching Safety Chains

Figure 8a shows a concept model developed for attaching the safety chains to the vehicle with limited dexterity. The stacked corks represent a grab handle that can easily be gripped with a prosthetic hand. Figure 8b shows a CAD model of the same concept.

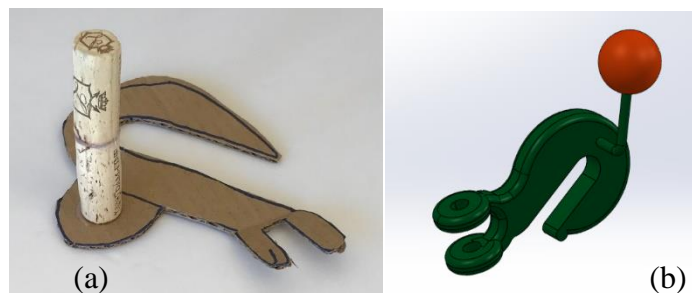


Figure 8: Concept model and concept CAD for modified safety chain hook.

4.3.2 Function: Inserting Hitch Pin

Figure 9a shows a concept model for a hitch receiver fitted with a captive hitch pin. The concept eliminates the need for a cotter pin since it incorporates a retainer that is attached to the receiver.

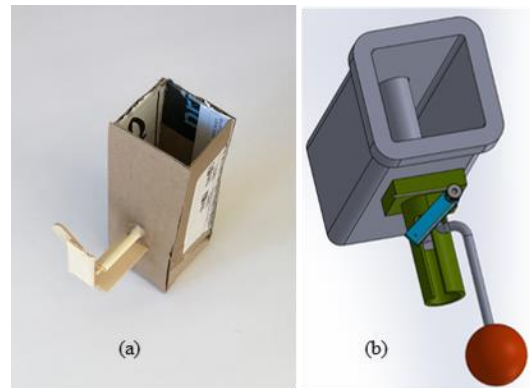


Figure 9: Concept model and concept CAD for receiver with captive hitch pin

4.3.3 Function: One-handed operation of electrical connector weather cover

Figure 10 shows a concept model for keeping the electrical plug doors open. The bits of foil and marks on popsicle sticks represent magnets that will hold the door either open, so the plug can be accessed, or closed, to keep contaminants out when not in use.



Figure 10: Concept model for electrical connector weather cover.

4.3.4 Function: Changing Ball Sizes

Figure 11 shows a picture of our concept models for the function of changing ball sizes. Figure 11a uses different size balls on a rotating platter. We wanted an axis of rotation in line with the

hitch, so concept Figure 11c was made. For our final design, we chose something similar, but with different means of supporting the hitch. Figure 11b is the CAD model for our chosen design direction.

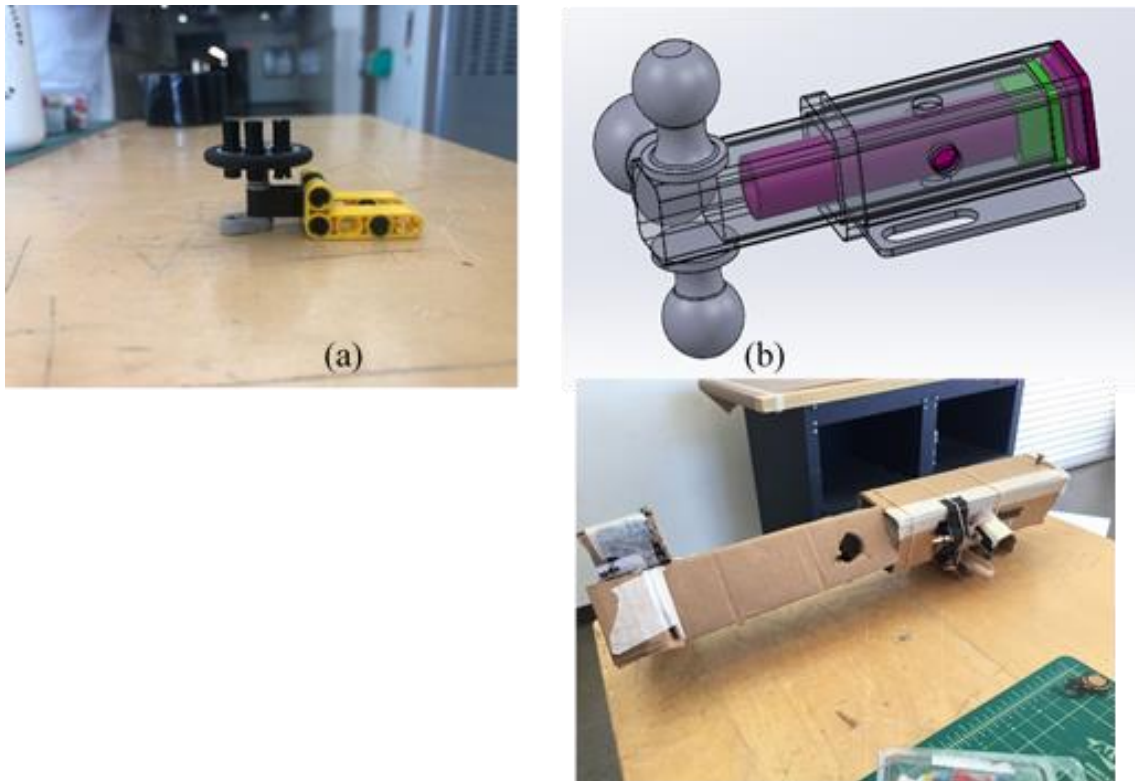


Figure 11: Concept model (a) and CAD (b) for ball changing mechanism.

4.3.5 Function: Attaching Safety Chains

When discussing the safety chain problem, we thought about completely changing the safety retention system. Figure 12 is a concept model of a system that uses rods that get inserted and locked in a hole to keep the trailer attached in case of an emergency. After making the model and discussing the problem more thoroughly, we decided it was best to go with the simpler and more obvious solution to the problem: hooks.

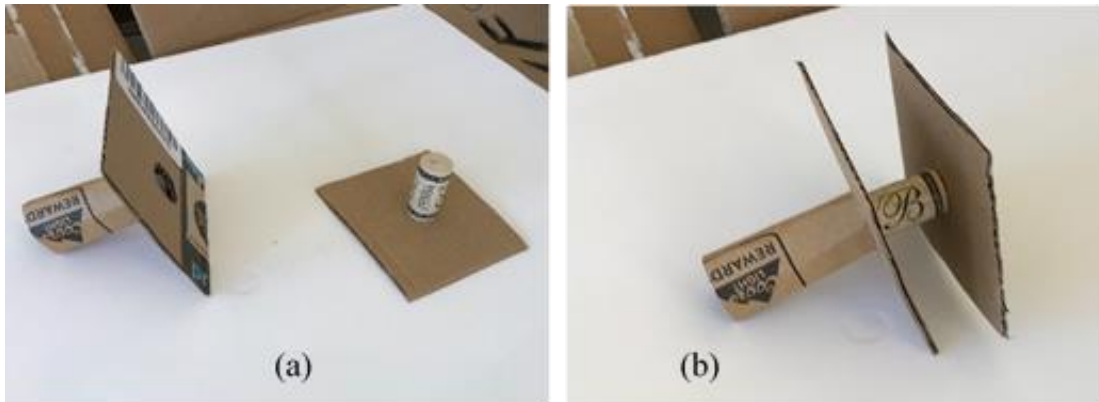


Figure 12: Concept model for alternative safety chain locking mechanism.

4.3.6 Additional Concept: “Black Box”

The concept model in Figure 13 is an idea that we explored for a mobile and self-contained trailer attachment machine. The “black box”, as we call it, is meant to be attachable to the trailer coupler without any tools. Once attached, it is used to position the coupler above the trailer ball, lower the coupler onto the ball, and actuate the tongue lever to lock the coupler to the ball. We chose to exclude this function from our project once we performed preliminary analysis on its functions. Trailer coupler designs vary widely, depending on the type and manufacturer of trailer. Consequently, it would be infeasible to develop a “black box” that would fit all trailers. Since electric tongue jacks (see Figure 5) are available at reasonable cost, it will be more economical to simply replace Taylor’s current tongue jacks with electric ones. Moving forward, we will focus on solutions to the more obscure problems associated with hitching a trailer to Taylor’s tow vehicle.

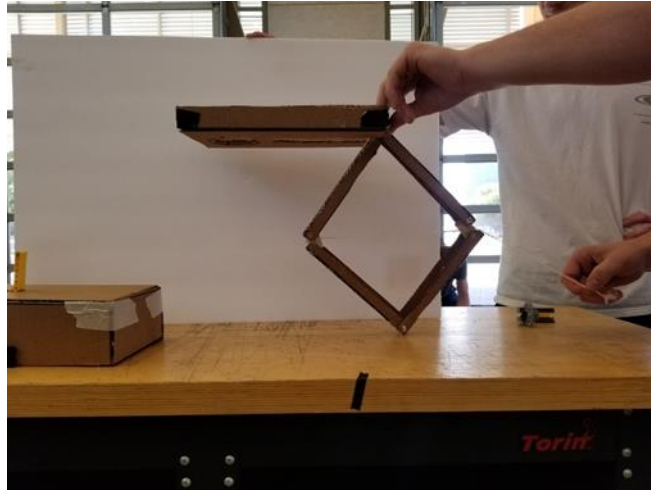


Figure 13: Concept model of the "Black Box"

4.4 DECISION MATRICES

Once the design concepts were narrowed down to the best three or four for each function, we used decision matrices to evaluate designs against both each other and relevant criteria. The first round of decision matrices involved using Pugh matrices, which are binary systems that evaluate each concept against a datum concept. The datum concept is usually a pre-existing one. Values were assigned as better (1), worse (-1) or the same (0) for various criteria pertinent to the function. The purpose was to verify that the front running idea deserved to be there. The secondary purpose was to promote idea generation. The Decision and Pugh matrices can be found in Appendix E. A decision matrix was used to compare our best ideas based on their qualities with weighted criteria. These qualities come from our specifications list. The final selections were modeled in CAD. The decision matrix helped us evaluate ideas that would contribute to the optimal performance for the entire system. Some ideas, including the one we refer to as “The Black Box” advanced to the CAD stage before we realized there was a better solution.

5 FINAL DESIGN

5.1 CHANGING BALL SIZES: "TRI-BALL ROTATOR" SUB-SYSTEM

The mechanism for changing ball sizes has evolved since preliminary design. Instead of a spindle that supports the hitch when it overhangs the end of the receiver, there will be a sliding block and a shoulder bolt that supports the hitch and allows it to rotate. This takes up less space and supports the hitch with less cantilever, resulting in less vertical deflection of the hitch when it is extended. The process for Taylor remains the same, he can still slide it out of the receiver, turn it and slide it in again without having to pick it up or support the weight of the hitch.

shows an isometric view of the Rotating Hitch subassembly.

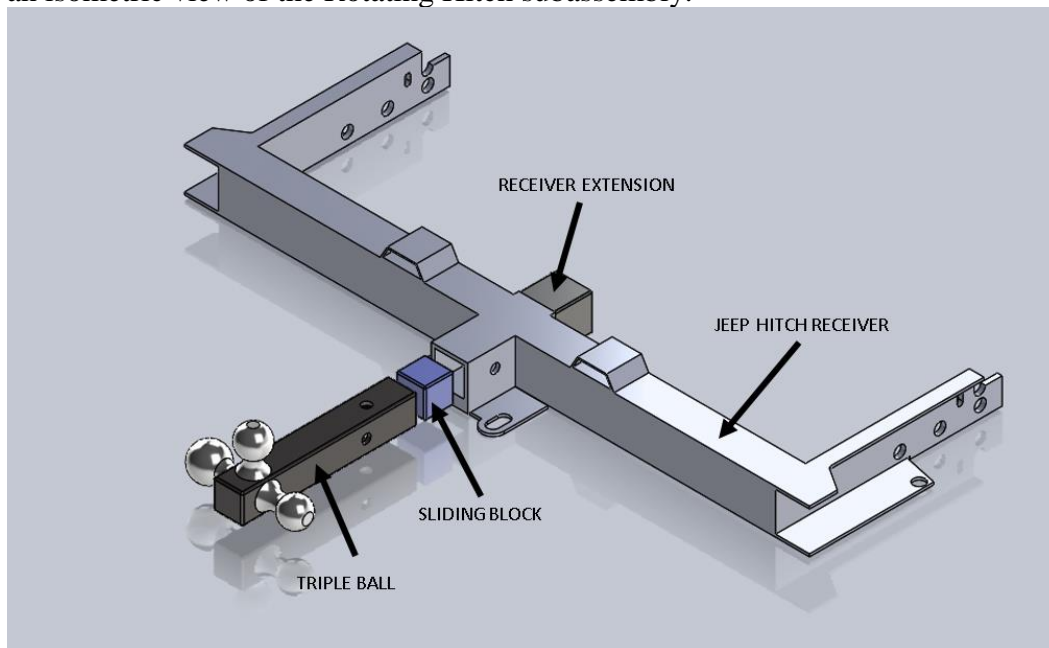


Figure 14: Isometric view of rotating hitch assembly

Error! Reference source not found. shows a section view of the hitch extended and stowed in towing position. The shoulder-bolt will be stainless steel to protect from corrosion and wear. It connects to the tri ball with a threaded hole which will be drilled and tapped in the end of the tri ball. The length of the shoulder is 1.5 inches, long enough to let the tri ball extend past the receiver so it can rotate, but not too long so the moment it carries is minimized. The ½-inch shoulder of the bolt and the 1-inch length of contact it makes with the sliding block ensure that the tri ball will be supported securely for the entire life of the product. The sliding block is constructed from 2-inch square steel tube with 1-inch steel plate inserted and welded in one side. Then a ½ inch hole is drilled in the center and then reamed to .501 inches so the shoulder of the bolt can slide easily and still be supported. Attached to the sliding block is a steel cable that connects to the hitch receiver and limits the block from sliding completely out of the receiver tube. This cable uses one carabiner in the connections so that the cable can be removed and the whole assembly can slide out. Removal of the entire assembly should only be necessary if a component needs to be repaired. The combined length of the tri ball and the sliding block require the receiver tube to be extended so the sliding block never fully comes out of the receiver tube.

This extension will be made with 2 inches of 2.5-inch steel square tube and then welded onto the rear of the receiver tube.

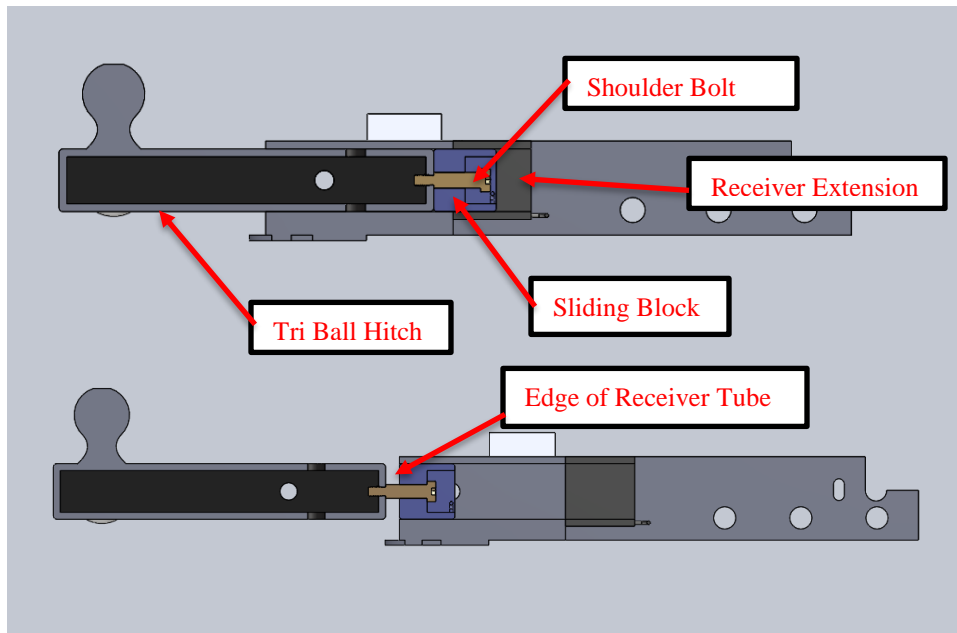


Figure 15: Section view of rotating hitch assembly in towing position (top) and extended for rotation (bottom)

To ensure these parts meet our requirement to be weatherproof, stainless steel will be used where possible and bare metal surfaces will be coated with durable paint. All parts carrying a load (sliding block and shoulder bolt) are over-built to ensure they last a lifetime without deforming or breaking. Also, all parts that we need to fabricate ourselves can be made very cheaply from raw materials. The whole assembly shown below will cost approximately \$300, with the jeep hitch receiver accounting for most of it (\$250).

5.1.1 Design Justification: Tri Ball Rotator

One of the main goals is to minimize the lifting process for Taylor. This system is designed to eliminate all lifting of the tri ball. We did some rough hand calculations that showed us that our ½ inch shoulder bolt would be effective at holding the 11-pound Tri ball for the duration of the products lifetime without deflecting. All Taylor must do is pull it out, rotate it, and push it back in. Through tests with the force gauge we found these actions only require a force around 10 lbf, well within Taylor’s ability. Also, through inspection we can see that these functions can be easily done with one hand in a short amount of time. To make sure all parts of this assembly are corrosion resistant we will use corrosion resistant materials or coatings. Aside from the shoulder bolt, which is stainless steel, all the parts are mild steel. To prevent these from rusting we plan on powder coating them in the CAED shop on campus. A powder coat will protect the parts from contaminates, rust, and scratches.

5.1.2 Safety, Maintenance and Repair: Tri Ball Rotator

The only safety concern with the tri ball rotating system is if the entire thing slides out of the receiver and falls to the ground, possibly damaging Taylor’s prosthetic legs. The only way this

could happen is if the limiting cable snaps. The cable will be made of braided stainless steel and will carry no significant load, so it is safe to assume that there is no way for the tri ball to fall out. There are no safety concerns associated with the actions of pulling out, rotating, and pushing back in the receiver.

We do not anticipate this assembly to need maintenance or repair. The shoulder bolt threads have Loctite holding them and making sure the bolt will not loosen over time. The tri ball can be completely removed if necessary, by detaching one end of the limiting cable using the eye bolt. Removal of this piece could be for repair of a broken part or to clean and lubricate the moving parts that have gathered in the receiver tube.

5.2 ACTIVATING COUPLER: “COUPLER LEVER” SUB-SYSTEM

Locking and releasing the tongue lever is difficult with a prosthetic hand. The motion requires strength and dexterity. Using a force gage and a coupler we bought for testing we determined that closing the coupler over a 2-inch ball requires 85 inch-lbs of torque with a pristine coupler. We know from photos that at least one of Taylor’s trailers is extremely corroded. It was important that we design something with significant mechanical advantage so that it would no longer be necessary for Taylor to hit the coupler tongue with a rock.

A major obstacle to designing the tongue lever was a lack of information on the couplers it was being designed for. Couplers come in many sizes and configurations. Of Taylor’s three trailers we received pictures of two and measurements of one. The other two trailers were covered in snow and so we were told it would not be possible to get measurements of them. Taylor communicated to us that if the lever worked for coupler with the measurements, it would be good enough. To us, this was too simple given the time we had and we decided to move forward with a design that will hopefully work on a range of coupler geometries; at a minimum it will at least work for the coupler shown in Figure 17. Thankfully, this coupler is a lot like the one we have for testing.



Figure 16: Taylor's Trailer Couplers: (a) without measurements (b) with measurements

Our original design for the coupler lever works by pinching the trailer coupler handle near the fulcrum. The two flat surfaces on either side of the mechanism are common to most of the coupler designs we have seen. An internal spring system in the body of the lever provides enough grip force that the lever will hold itself in place (see Figure 17). As Taylor slides the collar forward, the plain profile on the sides of the collar pulls the wings in and increases the grip force in the flanges. The grip force deforms the rubber pads on the inside faces of the flanges resulting in a tight, distributed grip on the coupler. When the collar is moved to its maximum forward position the coupler release lever rides along the incline until releases. The result is a two-step, one-handed operation to attach the lever to the coupler.

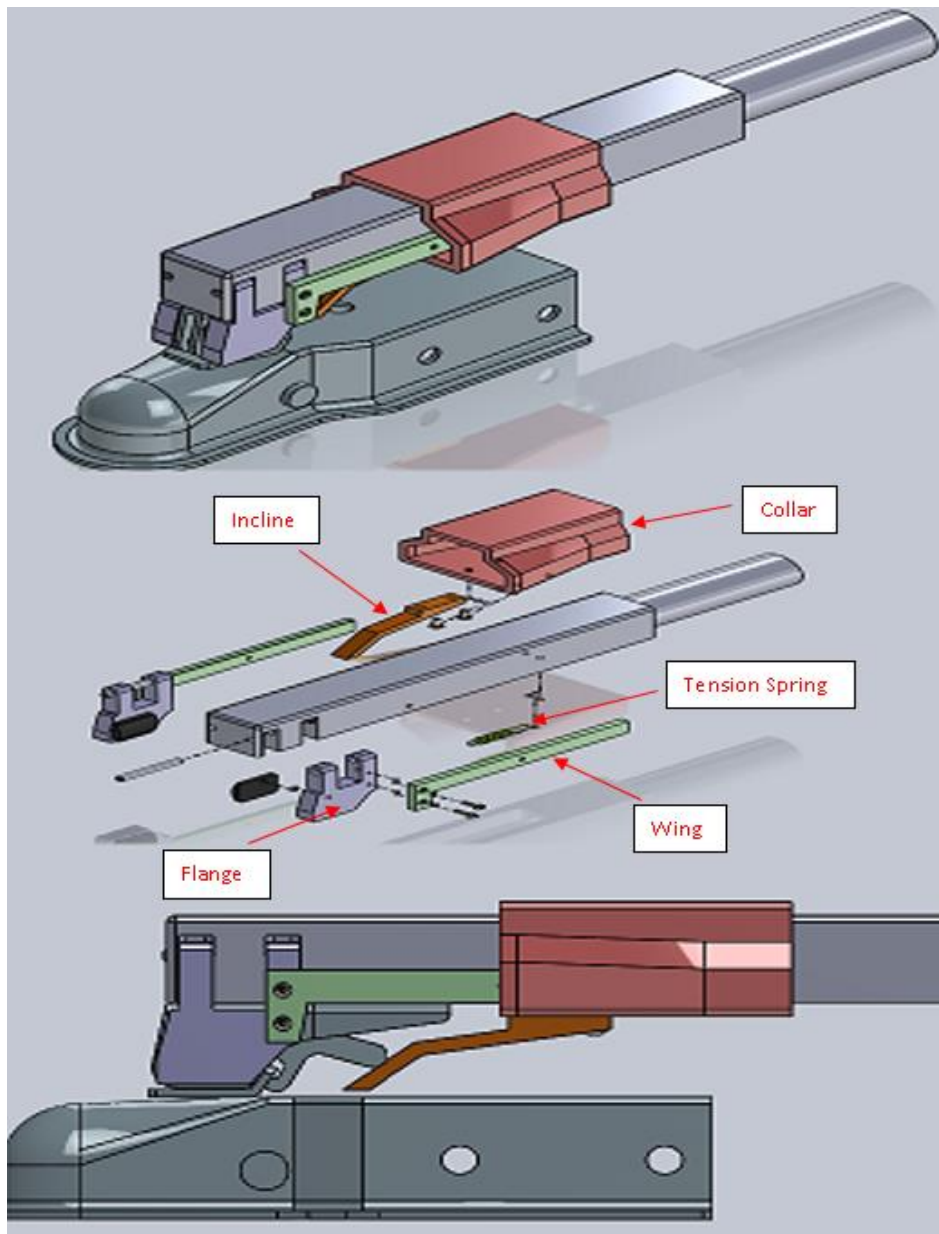


Figure 17: CAD of the Coupler Lever

Though we expected the design above to function, we had concerns that it would not be simple enough to work with just one prosthetic arm. Once we built a functional prototype, we found that it was difficult to use and did not meet our force specification. In the event that the original coupler lever is not practical for Taylor to use, we have created a second failsafe design for the couple lever the will require less dexterity to operate but will only work with the single most common type of coupler.

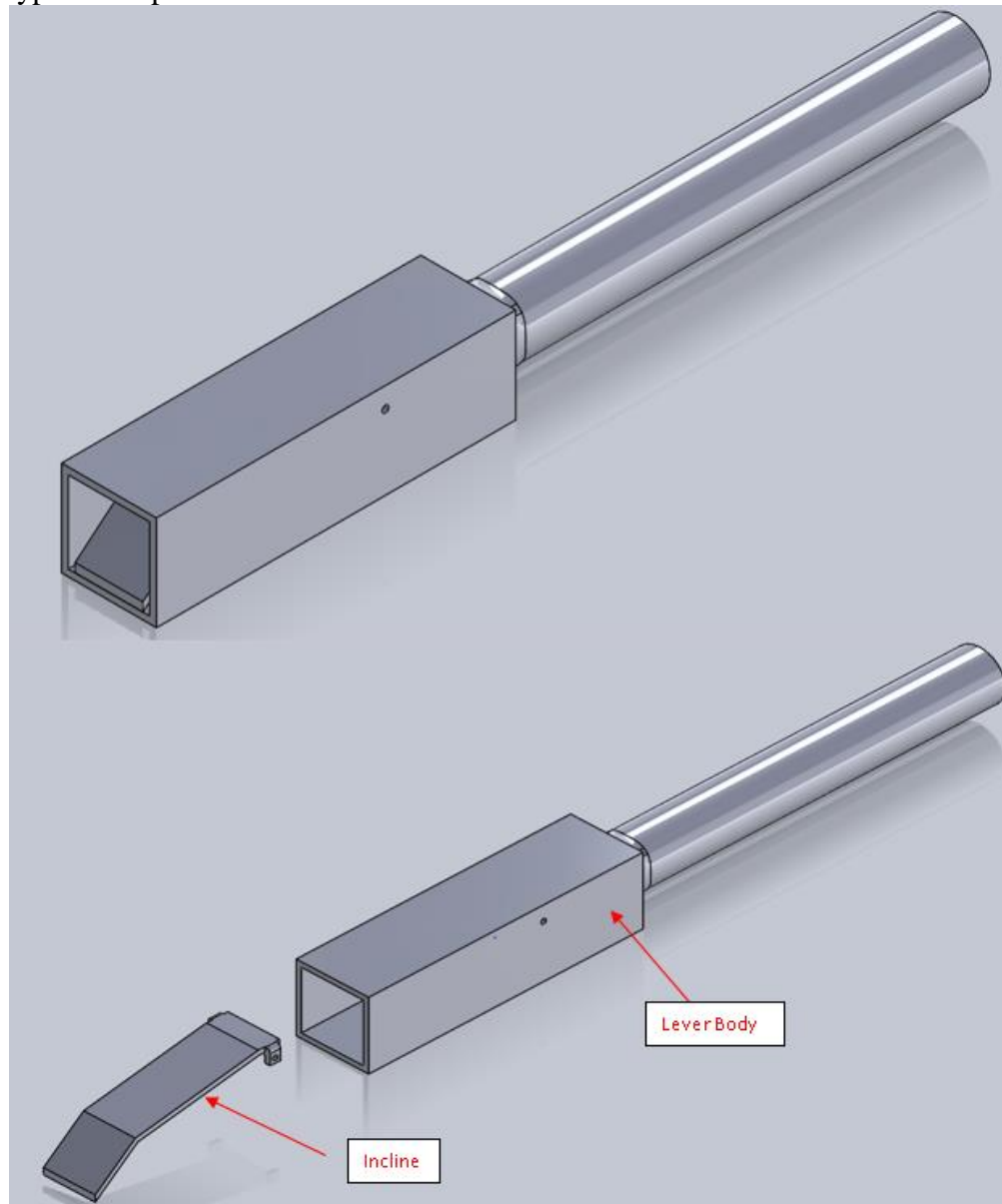


Figure 18: CAD model views of the Fail-Safe Coupler Lever

5.2.1 Design justification: Tongue lever

The design in Figure 17 can accomplish closing and opening the coupler around the ball with one hand and with no electromechanical components. The deformability of the pads and the

clamping action of the wing/collar assembly means that this design should work with a variety of different widths of the coupler lever. It should work with both couplers (a) and (b) from Figure 17. Additionally, the 18-inch lever arm only requires 5lbf applied to its handle to generate an 85 in-lbf moment to close the tongue lever. The material section for the tongue lever was not based on the factor of safety. We chose material because they were sturdy and easy to work with. The yield stress for 6061 Aluminum is 40,000 psi. If you refer to *Appendix 16* you will see that the max bending stress in the coupler lever due to the design criteria of 25lbs of force is 928 psi. This gives us a safety factor against static yield of 43.

5.2.2 Safety, Maintenance and Repair: Tongue Lever

The coupler lever will not be on the trailer during towing, so it is not a safety hazard. Early in the design process Taylor expressed concern that some of our ideas for this part could damage one of his prosthetic arms. We do not believe any of the motions required to operate the couple lever could damage one of his prosthetics. The design in Figure 177 is robust and simple. It will likely not require much repair or maintenance since corrosion resistant materials and methods of production (i.e. Stainless steel, aluminum, painting vulnerable surfaces). It is possible that the internal spring may wear out over time, but if it is kept accessible someone close to Taylor could easily replace it. Weight savings is a goal of future iterations of the design, but if we build the mechanism with a conservative safety factor it should last a long time without needing major repairs.

5.3 INSTALLING HITCH PIN: “PIN RETAINER” SUB-SYSTEM

5.3.1 Background Information: Hitch Pins

A hitch pin is used to retain the trailer hitch inside the vehicle-mounted receiver. Typically, it is retained using a cotter pin (shown in Figure 1), which is essentially a spring-loaded clip that prevents the hitch pin from sliding out during use. Taylor’s prosthetic does not enable him to easily remove and keep track of a cotter pin.

5.3.2 Our final design: Pin Retainer System

The pin retainer system we have designed seeks to retain the hitch pin with a mechanism that can be operated with one hand. It uses fully captive components (so they cannot be lost during use). The one exception to this condition is the hitch pin itself, which is not captive. The rationale behind leaving the pin free-floating stems from the idea that the hitch pin is a standard part which wears over time and requires periodic inspection. Should the pin need replacement, no tools will be required. The pin can simply be replaced with a new one.

Figure 19 shows CAD model views of the *open*, *closed*, and *exploded* views of the hitch pin retainer. Refer to Figure 21 for pin retainer component identification. In the *open* state, the notch plate is clear of the groove in the hitch pin, permitting it to be removed from the receiver in preparation to change the tow hitch (Tri-Ball). In the *closed* state, the notch plate interlocks with the groove in the hitch pin. The notch plate is designed such that the groove in the hitch pin will never make radial contact with the notch plate, to reduce cyclic loading of the spring and pin retainer components. The only loading that the notch plate experiences is axial (along the axis of the hitch pin).

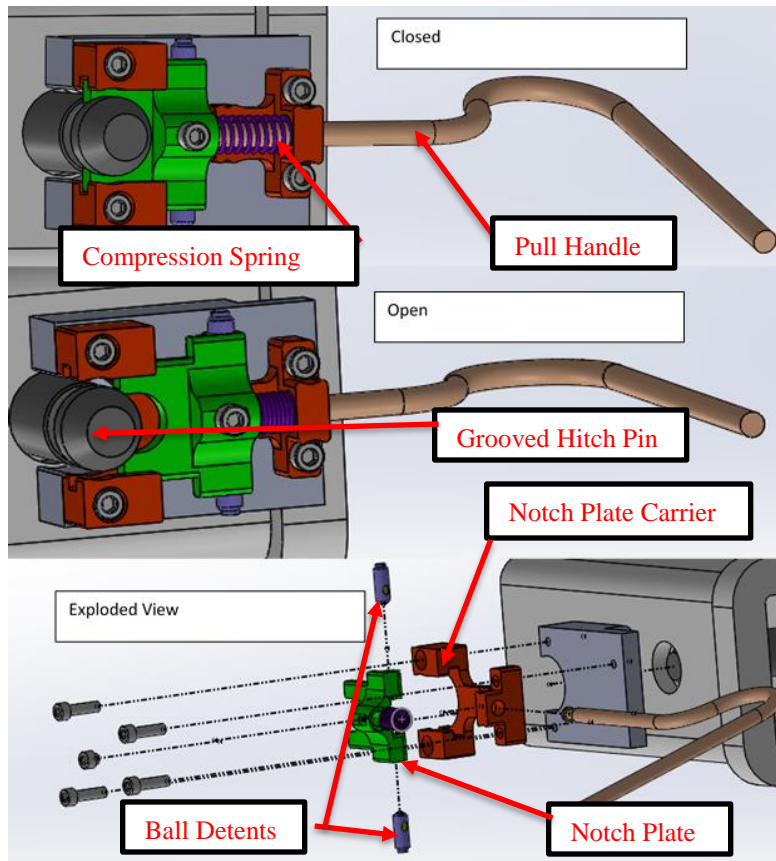


Figure 19: CAD model views of the pin retainer system

When using the trailer hitch system, Taylor can only perform one-handed operations. This means that the hitch pin retainer must lock in the open position so that it stays open while the hitch pin is removed. In Figure 20, a close-up view of the locking mechanism which serves said purpose is shown. Ball detents (QTY 2) are mounted in the notch plate and click into divots located in the notch plate carrier. The net force sustained by the ball detents along the sliding axis is slightly larger than that carried in the compressed spring, enabling the ball detents to hold the mechanism open. Refer to Figure 21 for hitch pin retainer component identification.

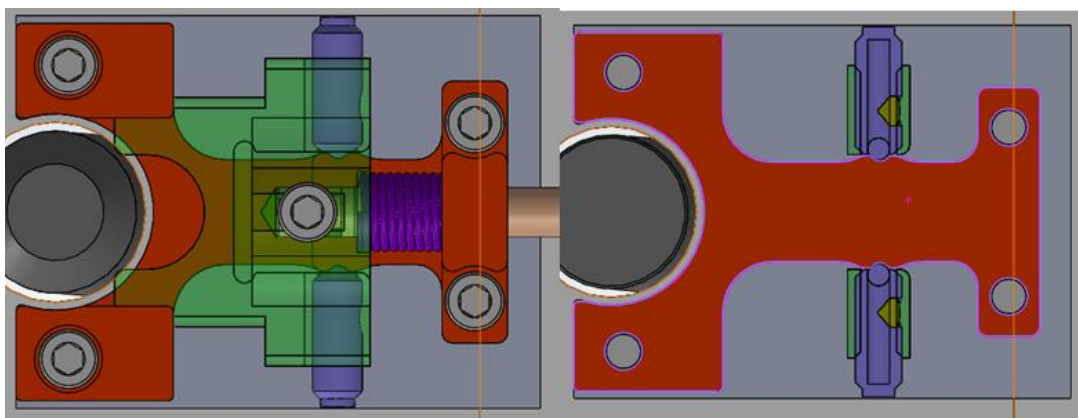


Figure 20: Detail view of ball detent restraining mechanism

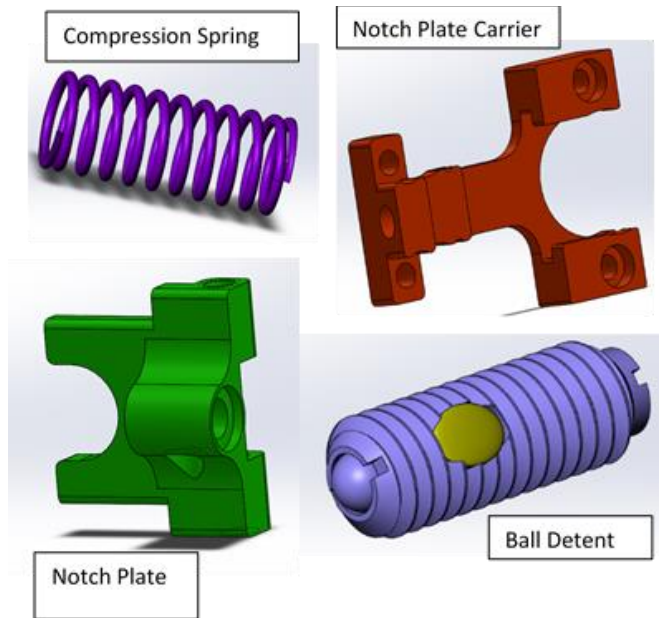


Figure 21: Hitch pin retainer component identification

Figure 22 shows the structural prototype in the open state (left) and closed state (right). A machine screw is used in lieu of the custom pull handle due to time constraints. The notch plate carrier is fastened to the base plate using four (4) #6-32 machine screws. This enables easy removal of the custom pin retainer system so that an alternate hitch pin can be used should the need arise, and so the system can be refurbished with new components if the notch plate and notch plate carrier wear over time.

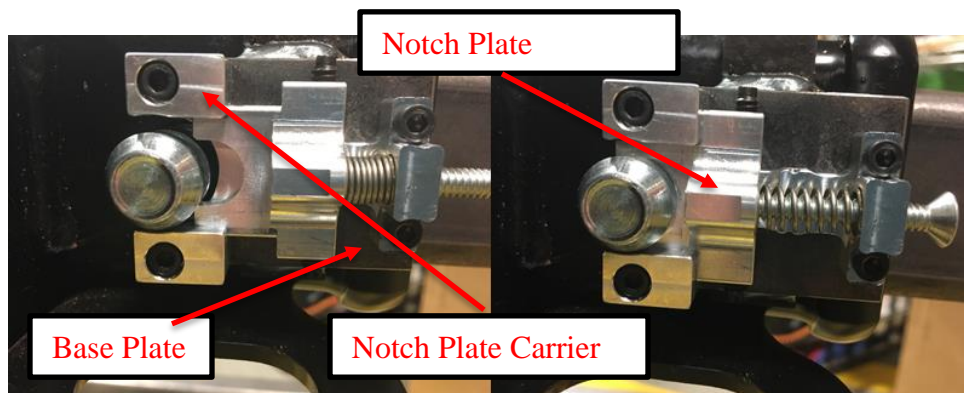


Figure 22: Hitch Pin Retainer structural prototype in the open (left) and closed (right) configuration

5.3.3 Design Justification: Hitch Pin Retainer

The main engineering specifications that are relevant to this system are 1) the input force required by the user and 4) Accessibility/Simplicity in use. Specifications 2), 3), and 5) in Table 1: Trailer hitch specifications table are less critical but still important for the safety and longevity of the system.

To estimate the maximum input force by the user, the critical load case was considered. The critical load case occurs when the user is opening the mechanism (compressing the spring) and clicking the ball detents into their notches. Detailed hand calculations are included in Appendix

F: Analyses. The analysis model used for the force exerted by the ball detent during preload is shown, along with a free body diagram of the notch plate with the compressed spring force and ball detent force. The estimate for the required user input force is 10.5 lbf. A simple force test was performed using a force gauge on the notch plate and resulted in a required 11.2 lbf to actuate the mechanism. This result indicates that the force analysis has good validity as a baseline estimate, and that the mechanism meets specification 1 for a maximum user applied force less than 25 lbf.

The capacity of the pin retainer in the sense of its ability to retain a pin is more difficult to model than the actuation force. A baseline calculation was performed on one side of the notch plate, treating it as a cantilever beam. This proved to be quite inaccurate, as it did not account for the load distribution across the surface of the notch plate and consequently under-estimated the bending stress in the notch plate. FEA in SolidWorks was also performed and showed that the notch plate will be able to support an axial load of approximately 100 lbf in its current configuration. Compared to the capacity of a cotter pin (also estimated in the analysis section), this is a low number. There is not a specification on the required force sustained by the pin retaining system (whether it be a cotter pin or other) [16], and 100 lbf is far more than the retaining system will see under normal operating conditions. The hitch pin only tends to slide out due to inertial forces resulting from vehicle cornering, and from vibration.

Stainless steel was chosen for the notch plate, notch plate carrier, machine screws, compression spring, and handle. This will ensure the pin retainer will meet specification 3: weather resistant. The moving parts also need to be made of a material that is wear resistant, and stainless steel is a better choice than aluminum in that case, although aluminum is easier to machine and less expensive. The plate that mounts the notch plate carrier to the hitch receiver needs to be mild steel so that it can be welded. This is not detrimental to the weather resistance of the system, since the plate can be painted before assembly to match the rest of the receiver.

5.3.4 Safety, Maintenance and Repair: Pin Retainer

The main concern for maintenance in the pin retainer system is the divot in the notch plate carrier which interlocks with the ball detents. The aluminum prototype shows slight wear after testing and exercise of the mechanism. The stainless steel we chose is much harder than aluminum, so the wear issue should be mitigated for the confirmation prototype. A potential safety issue with the mechanism could arise with pinch points between the notch plate and notch plate carrier; this issue is mostly eliminated by the pull handle attached to the notch plate which keeps the operator's hand far away from moving parts.

5.4 ATTACHING SAFETY CHAINS

Taylor's problem removing the carabiners from the connection points on the receiver had a simple solution that involved purchasing new hooks. Most safety chains come with open ended hooks rather than carabiners. Research has been performed regarding the legal requirements of trailer safety chains. Our research has led us to the conclusion that safety latches are not required on safety chain hooks. With that confirmed, we have selected some certified, open-ended towing hooks to replace Taylor's carabiner hooks.

The safety chain hooks are painted for corrosion resistance and weigh far less than 25 lbf. No testing or analysis has been performed for this subsystem,

5.5 CONNECTING TRAILER LIGHTS: "ELECTRICAL RECEPTACLE" SUB-SYSTEM

Currently, connecting the trailer's lights to the car is a two-handed operation that Taylor struggles with. The door to the plug must be held open while the plug is inserted. To make this a one-handed operation, we removed the torsional spring that constantly applies a force that keeps the door closed. We took a different approach to either side of the receptacle. On the smaller side of the receptacle we were able to find space on the receptacle itself where we can modify the housing and place the magnet directly in the part. On the other side of the receptacle we could not find the appropriate amount of space needed to place the magnet inside the receptacle. So instead of heavily modifying the receptacle we have designed a cage that will hold the magnets on either side of the receptacle and allow the magnets to make contact with the hitch receiver. The cage will be glued down to the top of the larger door of the receptacle. The cage by itself can be seen in Figure 23. The cost of these modifications and additions are very low. The cost of each part can be found in Table 6: Procurement Information for Adapted Trailer Hitch Confirmation Prototype.

5.5.1 Design justification: Electrical Receptacle

We have performed a pull test on the Electrical receptacle doors and have found that the torsion springs hold the doors closed with approximately 3 pounds of force. We have selected a neodymium magnet that has a two-and-a-half-pound pull force that we will install on both sides of the electrical receptacle.

5.5.2 Safety, Maintenance and Repair: Electrical Receptacle

The receptacle will remain safe if it is kept weatherproof. With the magnets we have chosen, the seal will be compressed, and the weatherproofing will be maintained. The receptacle requires little maintenance and should not need to be repaired. If it needs to be replaced, the cage and magnets could be reused. Some modifications would have to be done to the replacement.

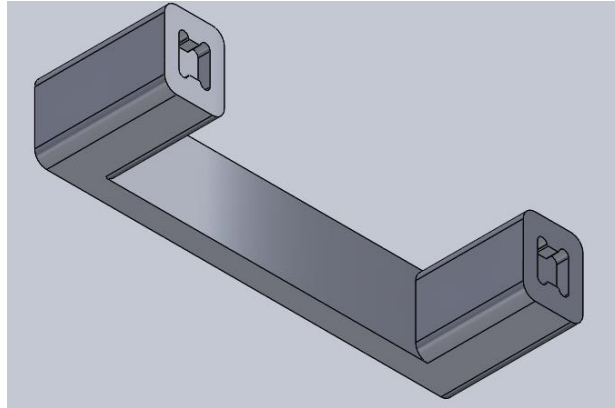


Figure 23: Electrical receptacle cage

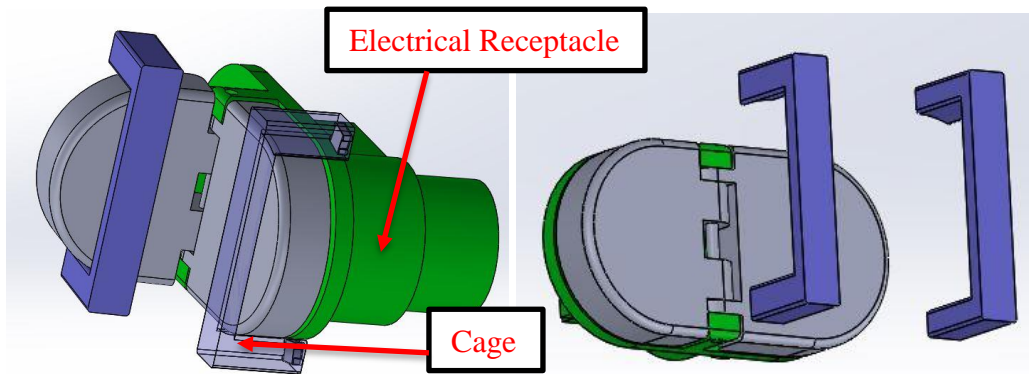


Figure 24: CAD model views of electrical receptacle with cages mounted (left) and an exploded view (right)

5.6 POTENTIAL ISSUES

As mentioned previously, we are not modifying any important structural components of the towing system to avoid partaking in extensive testing procedures outlined by the SAE (Society of Automotive Engineers) and DOT (Department of Transportation) organizations. The potential issues that we now see are testing our solutions to the different functions. We have developed with some testing ideas and criteria, but we may run into various issues in the testing phase. For example, we may find that some components are not weatherproof and do not hold up to the weatherproofing standard. As we begin more of our manufacturing, we may run into some issues with making several of the parts which is a concern. Specifically, some parts for the tongue lever parts may be difficult to manufacture and may need to be re-designed. There are a few safety hazards associated with this design. Appendix C contains a checklist of possible hazards and how we plan on preventing them in our design.

6 MANUFACTURING

6.1 PROCUREMENT

All specified materials for this project are tabulated in Appendix D: Project budget. Links to necessary purchasing websites are included. The total cost of purchased materials and components for this project is \$1014.50. All the stock material was purchased from McMaster-Carr. Some of our parts, including the hitch receiver and the force gauge, were ordered from outside vendors and those sources are noted in Appendix D: Project budget.

6.2 MANUFACTURING

All manufacturing operations detailed in this section were performed in the Mustang '60 Machine Shop unless otherwise specified.

6.2.1 Electrical Receptacle Manufacturing

6.2.1.1 Electrical receptacle modifications

The OEM receptacle from Mopar was modified by removing the door-close spring and adding a magnetic “Electrical Receptacle Cage” to the outside of each door.

6.2.1.1 Electrical Receptacle Cages

The electrical receptacle cages were CNC milled with reference to detail drawing TH3021 in Appendix K: Drawing Package. Figure 25 shows the part in the CNC mill after the last operation was complete.

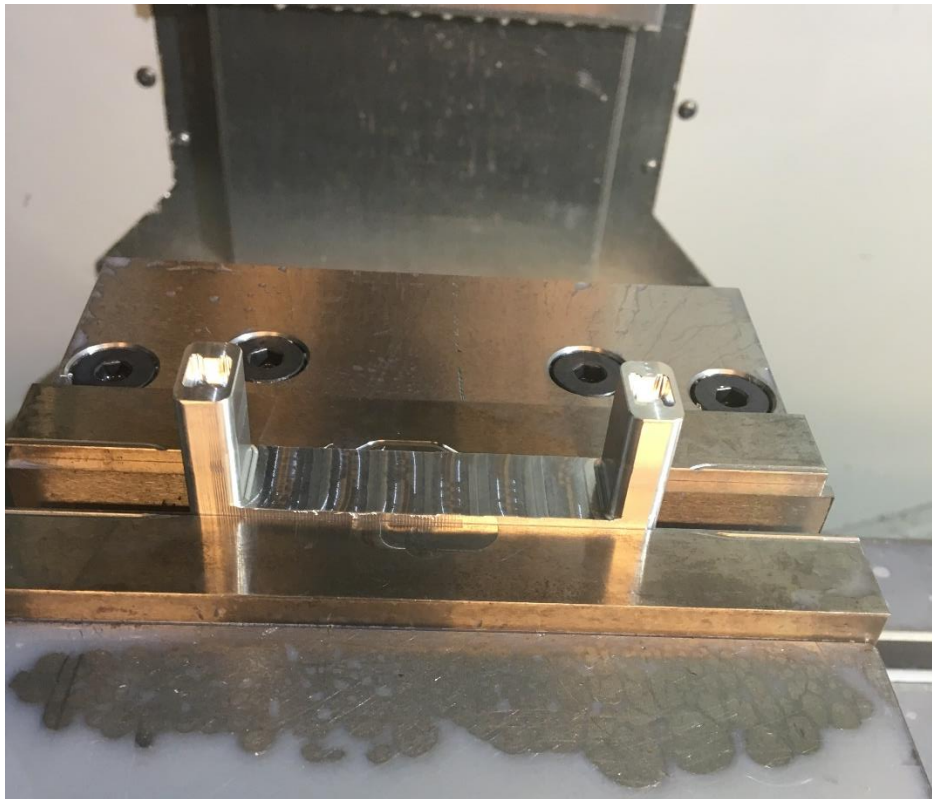


Figure 25: Electrical receptacle cage in the vise of the CNC mill.

6.2.1.1 Mounting the Electrical Receptacle Cages

The electrical receptacle cages were initially mounted as shown in Figure 26. The figure shows use of hot glue which was used to verify the functionality of the cages before permanently attaching them. After verifying the fit, the hot glue was removed and the cages re-mounted with two-part epoxy.

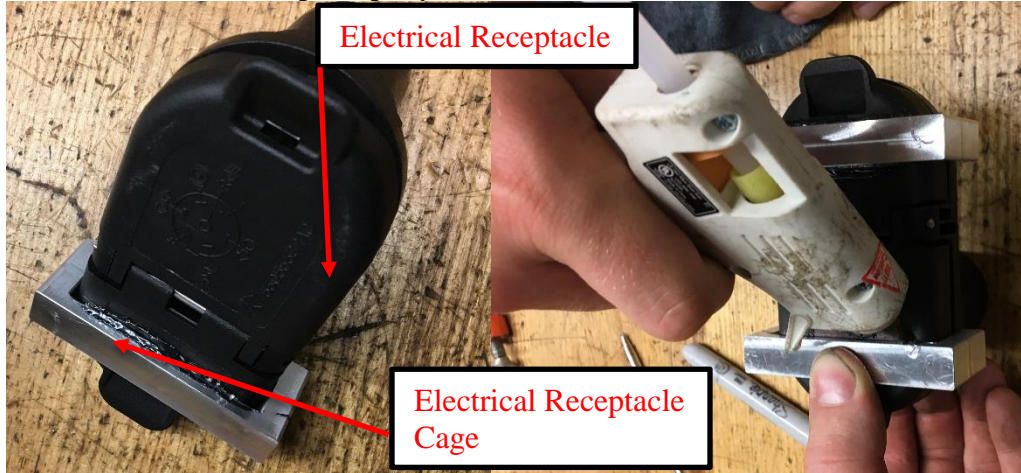


Figure 26: Mounting the electrical receptacle cages.

6.2.2 Tri-Ball Rotator Manufacturing

Refer to the assembly drawing TH2000 in Appendix K: Drawing Package for process drawings on the following operations.

6.2.2.1 Modifying the Tri-Ball Hitch

The Tri-Ball hitch was modified by adding a 3/8"-16 tapped hole in the end to receive the shoulder bolt.

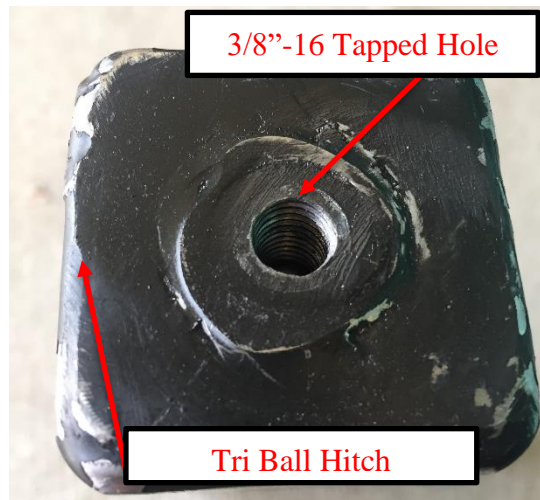


Figure 27: Tapped hole in end of Tri-Ball hitch

Operations Included:

- Clamping the Tri-Ball to a mill table and locating the center of the end face as the zero point
- Drilling a 5/16" pilot hole for tapping

- Tapping the hole with a 3/8"-16 cutting tap, utilizing tapping fluid

6.2.2.2 Making the Sliding Block

The sliding block was made from 2" square tubing fitted with 1" thick steel plate in one end. A small wire loop is welded behind the plate to connect the limiting cable.

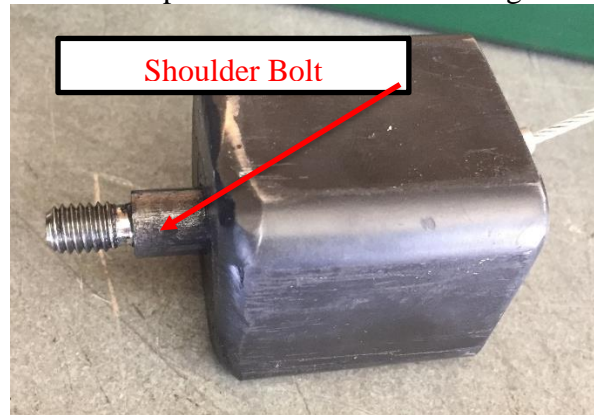


Figure 28: Completed sliding block with shoulder bolt inserted through .501" reamed hole

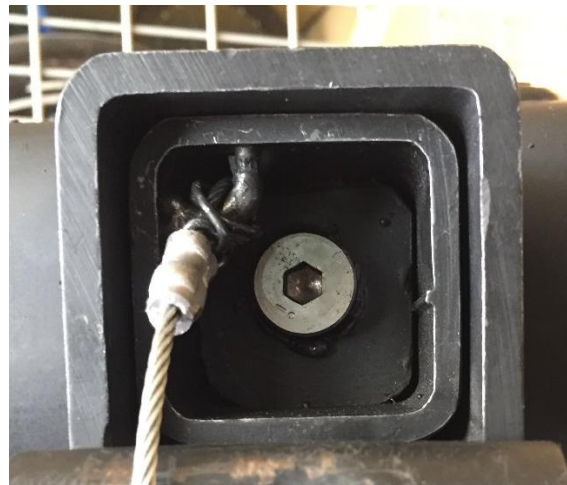


Figure 29: Sliding block with loop welded on to receive cable

Operations Included:

- Cutting 2" square tube to 2" length and de-burring edges
- Using an angle grinder to cut a 1.1" x 1.1" square out of the 1" steel plate
- Locating the steel plate into one end of the tube so it protrudes approximately 1/4"
- Welding the two pieces together with the MIG welder using a fillet weld all around
- Placing the weldment in the mill with the plate facing the spindle. Indicate the tubing walls parallel to the spindle axis
- Facing the end perpendicular to the walls
- Drilling and reaming the .501" hole for a slip fit on the shoulder bolt
- Welding 1/8" diameter wire loop behind plate
- Cleaning and sandblasting outer surfaces
- Painting and allowing to dry 24 hours

6.2.2.3 Adding the Receiver Extension

A receiver extension was added to the factory built Mopar receiver that fits a 2014 Jeep Grand Cherokee. It serves as a location to anchor the sliding block, and an implement to maintain its orientation when the tri-ball is in its towing (stowed) position. Figure 30 shows the receiver extension aligned with the main receiver tube before full welding was completed.

Operations Included:

- Cutting receiver tubing to length using an abrasive chop saw
- Preparing the factory-built receiver for welding extension
- Welding the extension on
- Painting the welded joint

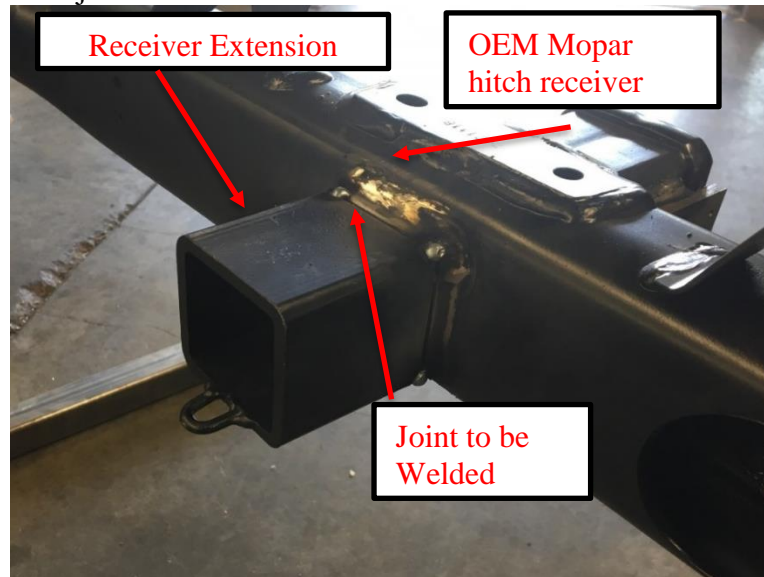


Figure 30: Receiver extension as welded to the OEM Mopar hitch receiver.



Figure 31: Receiver extension welded completely on

6.2.3 Pin Retainer System Manufacturing

6.2.3.1 CNC Machining the Notch Plate, Notch Plate Carrier, and Base Plate

The notch plate, notch plate carrier, and base plate were CNC (computer numerical control) milled on a 3-axis Haas VMC (Vertical Machining Center). All toolpaths for the machining were generated using the HSMWorks™ add-in for SolidWorks™. In-depth details of the operations are not provided as the information is not relevant to the procurement of future parts. If reproduction is necessary, provide the assembly and detail drawings from packet TH2010 along with the corresponding part detail drawings to a machine shop.

Notch Plate Operations:

Figure 32 shows the CAM toolpaths used for machining the notch plate. Operation a) of the figure is the first operation, which occurs from rough stock. Operation b) shows the part oriented in a position to machine the excess material from the back side, which was used to grip the rough stock in part a). Operation c) is performed twice (once for each of the cross-drilled holes). Operation d) finishes the machining process for the notch plate.

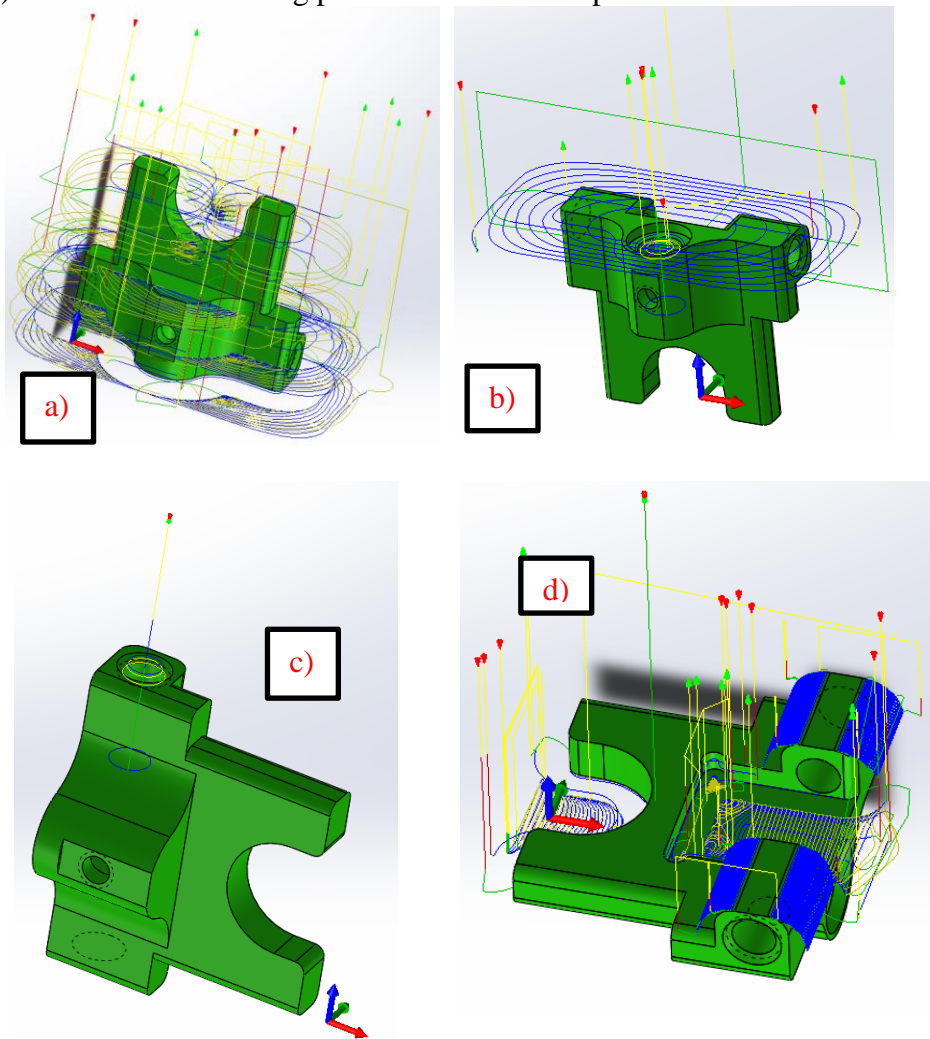


Figure 32: CAM toolpaths for the Notch plat

Notch Plate Carrier Operations:

Figure 33 shows the single machining operation for the notch plate carrier. The operation used a semi-sacrificial fixture (shown in gray in part a) of the figure) that the part was fastened to after the mounting holes were drilled and counter bored with the stock material clamped to the fixture (not shown).

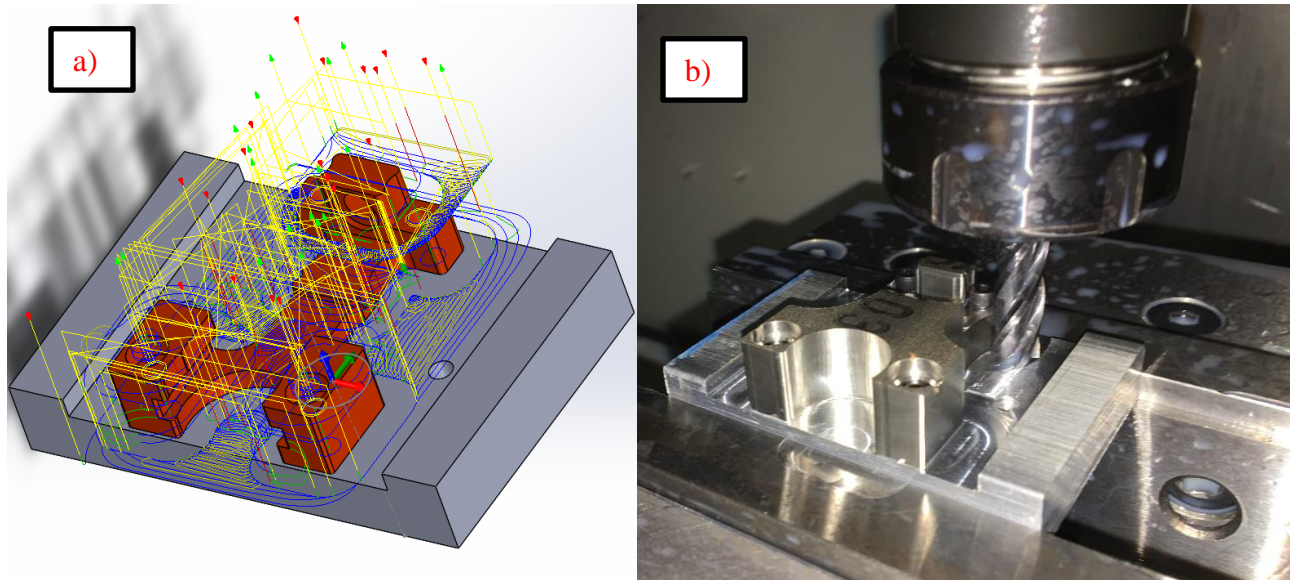


Figure 33: a) CAM operations and b) machining of the notch plate carrier.

Base Plate Operations:

In Figure 34, the base plate operations are shown. Part a) of the figure shows the CAM toolpaths that were generated for machining the part in two operations. Part b) shows the setup for the 2nd operation in the CNC mill.

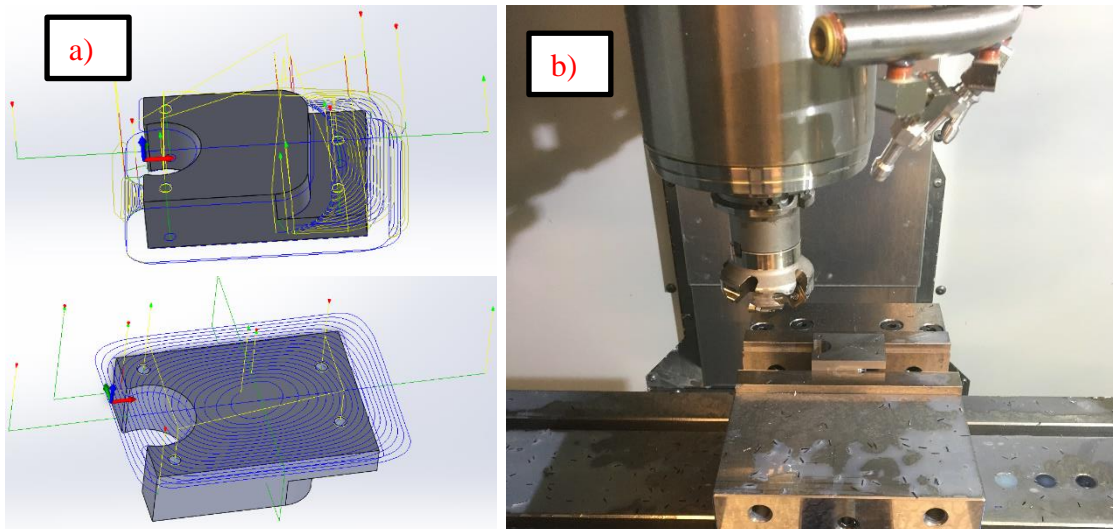


Figure 34: a) CAM operations and b) machining of the base plate

6.2.3.2 Making the Pull Handle

The pull handle was made with reference to drawing TH3014 in Appendix K: Drawing Package
Operations Included:

- Cutting the stainless-steel rod to the finished overall length (specified in the drawing).
- Using a key-seat milling cutter to create the retaining groove as shown in Figure 35.

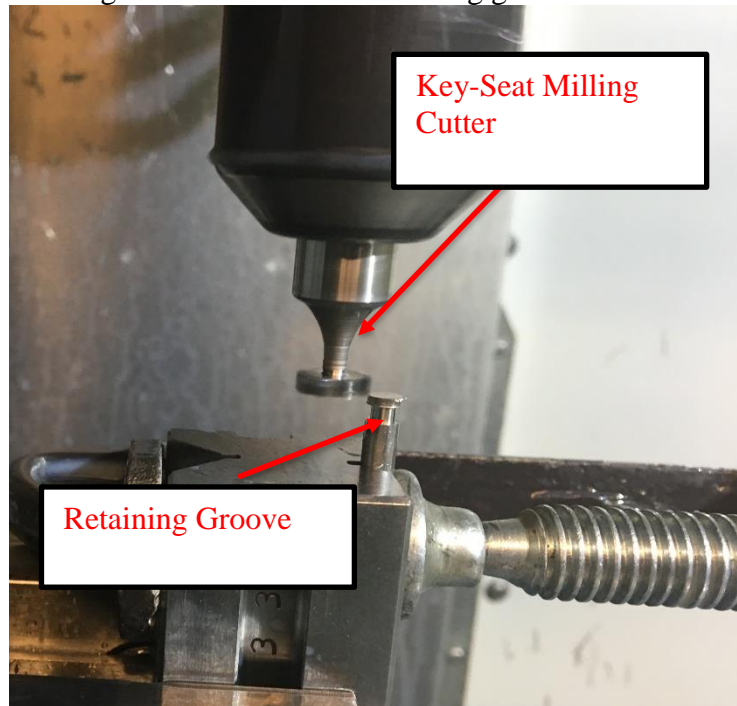


Figure 35: Milling the retaining groove in the end of the pull handle

- Bending the rod into the shape shown in the detail drawing.

6.2.3.3 Modifying the Receiver to Accept the Pin Retainer System

Referring to the process drawing for the pin retainer system, the receiver was prepared for welding. This involved removing any oils/paint from the weld vicinity. GMAW (Gas Metal Arc Welding) was used to weld the base plate to the receiver with the welds specified. The bare metal surfaces were then painted to resist corrosion.

6.2.4 Tongue Lever Manufacturing

6.2.4.1 Manufacturing of the Flanges, Wings and Incline.

Refer to tongue lever detailed drawings. (TH1010 & subsequent drawings listed)

The flanges, wings and incline are all parts with complex profiles in two dimensions and flat in the third. They were made from ½” thick aluminum bar stock. The right and left flanges and wings are the same part with holes and counter bores on the opposite side. These parts were cut using a waterjet and hinge holes were drilled as a post-processing operation. The waterjet used is in the Industrial Technology support shop at Cal Poly.

Operations for Flanges Included:

- Cutting the profiles out of ½ inch thick 6061 Aluminum with a water jet.

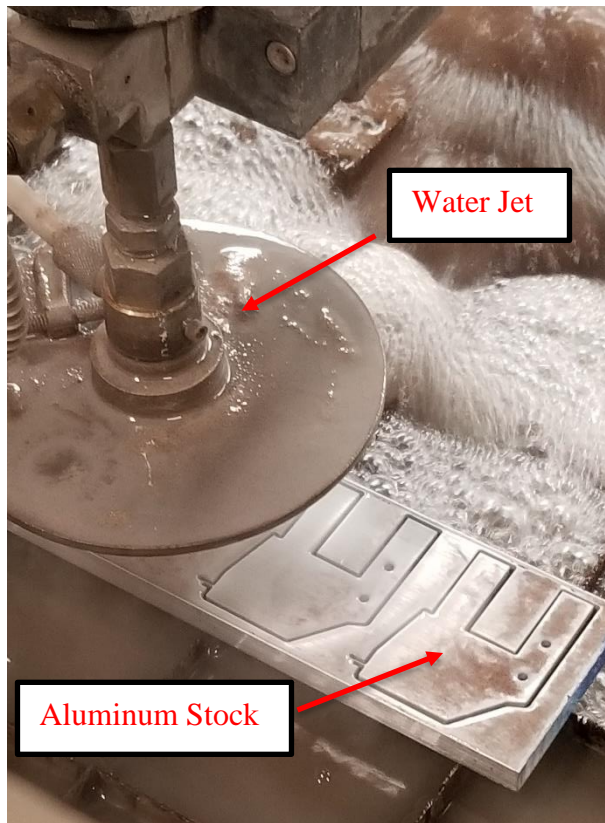


Figure 36: Water Jet Production of the tongue lever flanges

- Drilling the hole for the ¼ inch diameter shoulder bolt.
- Drilling and tapping the two #6-32 holes in the part.

Operations for the wings include:

- Cutting the profile out of ¼ inch thick mild steel with a water jet.
- Drilling and counter boring thru holes where the wing attaches to the flange using a drill press.
- Drilling the tension wire attachment hole on the wing body.

Operations for the incline include:

- Cutting the profile out of ½ inch 6061 Aluminum with the waterjet.
- Drilling and tapping the mounting holes using a manual milling machine.

6.2.4.2 Manufacturing the tongue lever body

Refer to drawing TH3031.

The pockets and holes bored in the tongue lever body were machined using a CNC mill from 1-3/4-inch square bar stock. In-depth details of the operations are not provided as the information is not relevant to the procurement of future parts.

Operations Included:

- CNC milling the lever body out of 1-5/8-inch bar stock.

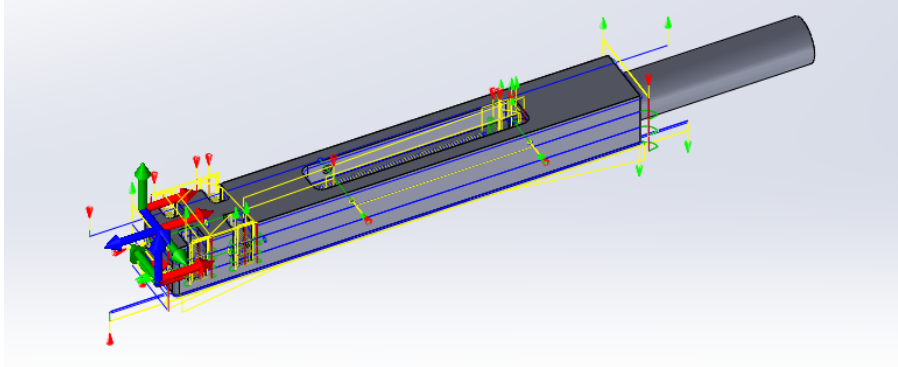


Figure 37: CAM toolpaths for the tongue lever body

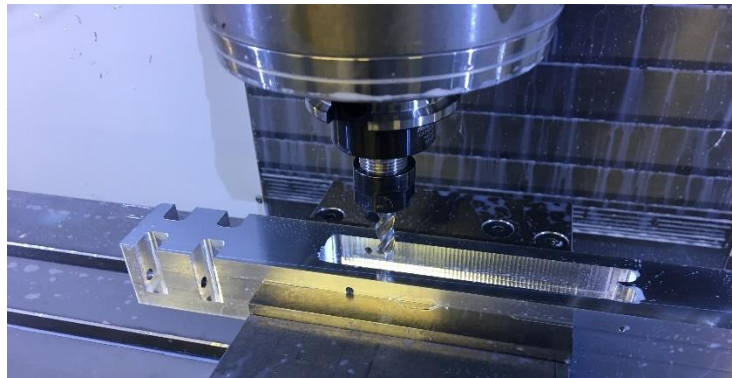


Figure 38: Machining of the tongue lever body

- Turning the end of the bar stock down to a 1-1/4-inch diameter on the lathe.



Figure 39: Turning the handle for the tongue lever

6.2.4.3 Manufacturing the Collar.

Refer to tongue lever detailed drawings TH3051

- The collar was 3D printed out of PLA.

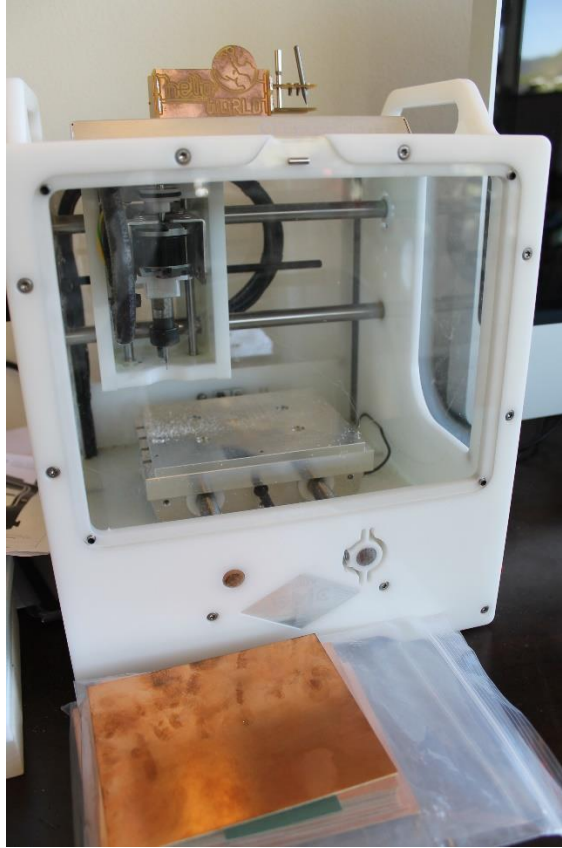


Figure 40: An example of one of the 3D printers used to make the collar

6.2.5 Tongue Lever Version Two Manufacturing (Tongue Lever B)

6.2.5.1 Manufacturing the incline

Refer to drawing TH3061.

Operations for the incline included:

- Using a Dremel with a cut-off disk to cut relief into the back of the bends
- Using a vise and a protractor to bend aluminum according to spec.
- Drilling and tapping holes in flanges.
- TIG welding flanges to the side of the incline.

6.2.5.2 Manufacturing the tongue lever body

Refer to drawing TH3062.

Operations for the incline included:

- TIG welding a piece of 6061 aluminum to the back of the section of square tube.
- TIG welding a section of aluminum tubing to the back.

6.3 ASSEMBLY

6.3.1 Tri-Ball Rotator Assembly

The Tri-Ball Rotator was assembled with reference to assembly drawing TH200 in Appendix K: Drawing Package.

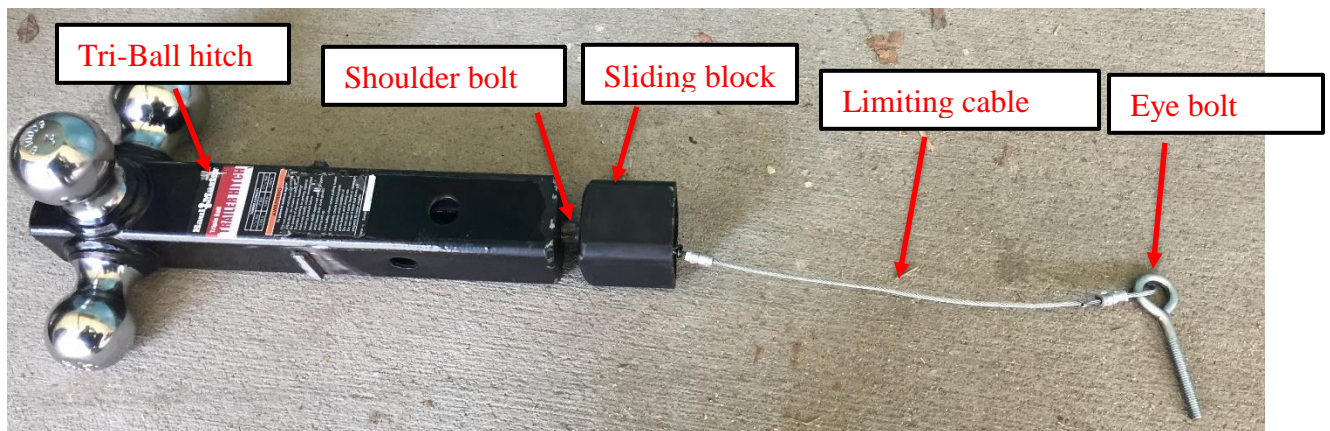


Figure 41: Completed Tri-Ball rotation assembly

Assembling the sliding block mechanism:

- Apply grease around the shoulder of the shoulder bolt

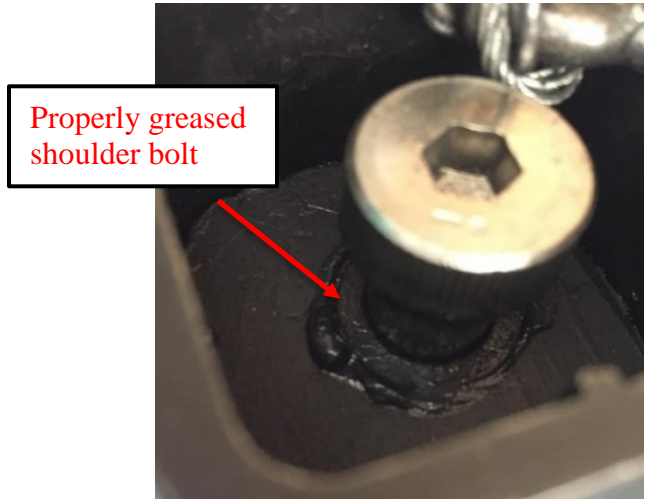


Figure 42: Shoulder bolt greased and inserted into sliding block

- Slide the shoulder bolt through the sliding block
- Apply a few drops of red thread-locker (available in the machine shop) to the threads

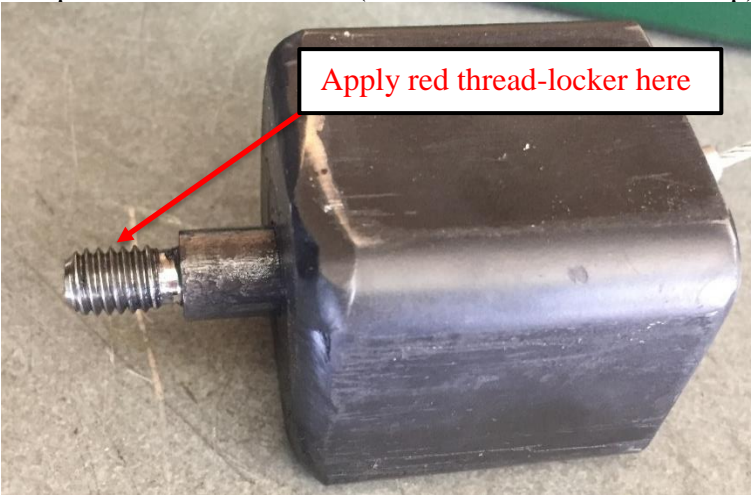


Figure 43: Applying thread-locker to shoulder bolt threads

- Thread the shoulder bolt into the Tri-Ball and tighten to 35 ft-lb
- Crimp one end of the limiting cable to the sliding block, leaving ~2ft of slack
- Measure the distance to the anchor location and crimp another loop into the cable through the eye bolt

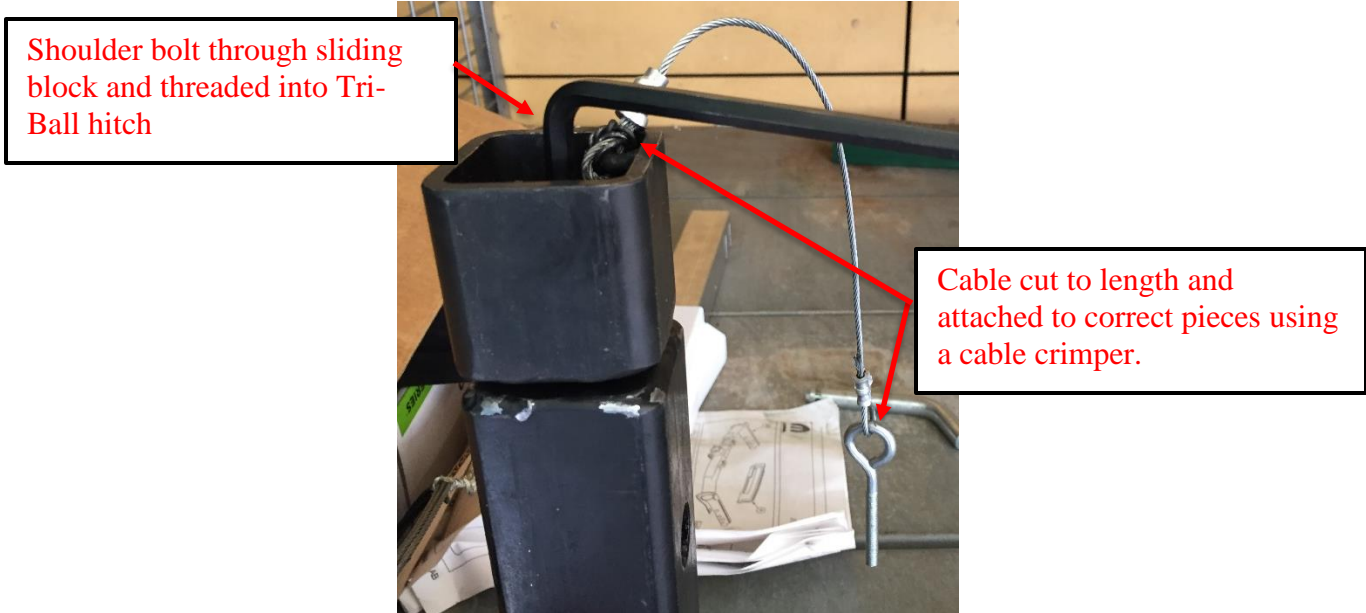


Figure 44: Attaching shoulder bolt and sliding block to Tri-Ball Hitch. Also shown is the crimped cable attached to the correct points

- Secure eye bolt to bottom of hitch receiver using two nuts
- Adjust length of the cable using the two nuts until the triple ball hitch just slides completely out of receiver tube

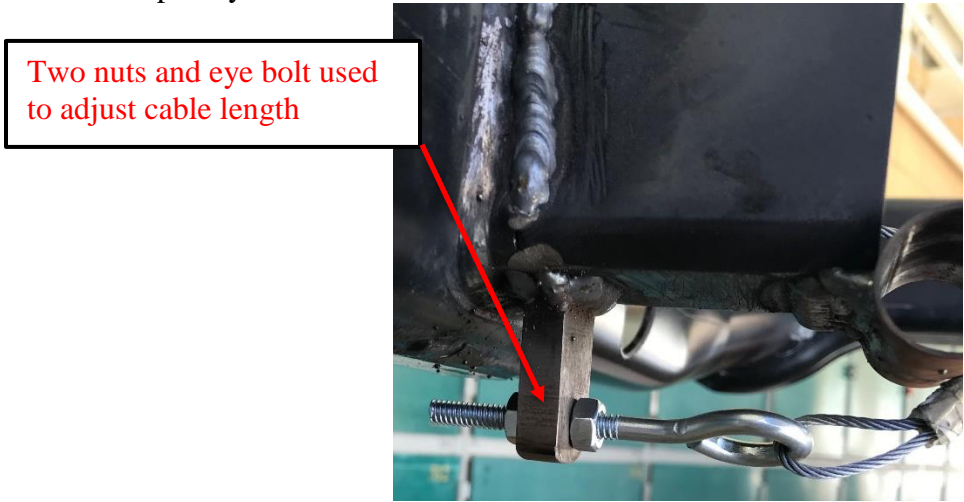


Figure 45: Eye bolt attachment to hitch receiver and cable length adjustment



Figure 46: Proper cable length adjustment results in this maximum Tri-Ball hitch extension

- Weld on small metal pieces to sides of Tri-Ball hitch so it stops in the receiver tube when the holes are aligned
- Weld 1" long piece to bottom of receiver tube so that when rotated 90 degrees the hitch stops when the proper holes are aligned

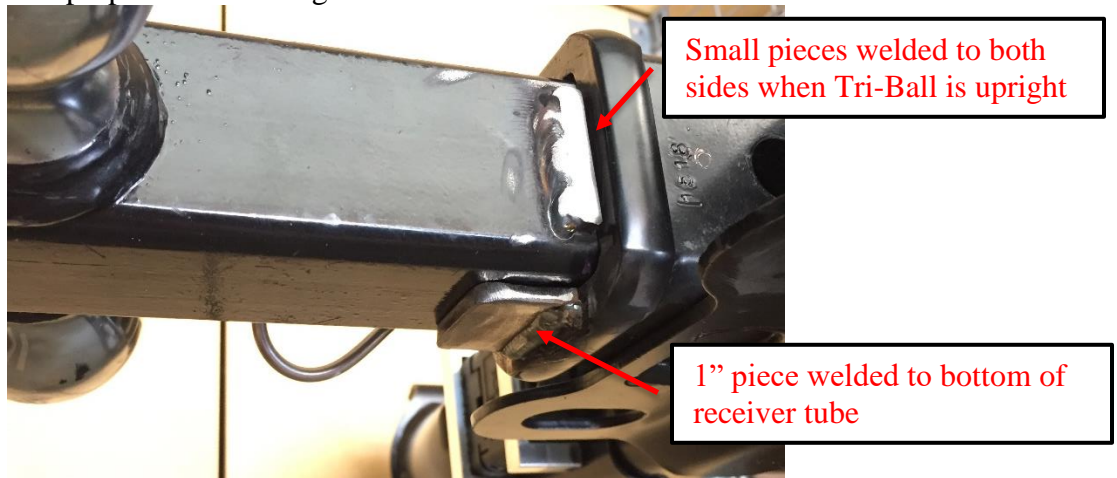


Figure 47: Proper placement of stopper plates so that Tri-Ball hitch always slides the correct distance into the receiver tube

The cable length was initially very hard to get correct because the length had to be perfect after the loops were crimped on each side. To fix this issue we instead attached one loop to an eye bolt. This eye bolt attaches to the receiver through a plate welded to the bottom. Using two nuts, the eye bolt can be fixed in place and the cable length can be adjusted to the exact length required so that the Tri-Ball slides out of the receiver just enough.

Another issue we had with the cable was the loop around the sliding block getting jammed in-between the sliding block and the receiver tube while sliding the Tri-Ball hitch back and forth. To fix this we wrapped thick wire around the cable loop and its attachment point so that it always points up and out of the tube, rather than swinging around and hitting the walls of the receiver tube.

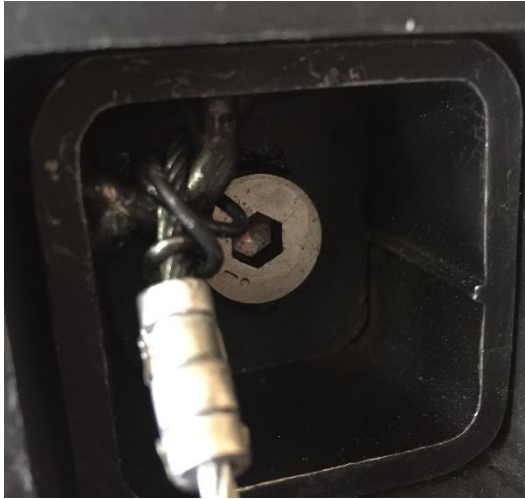


Figure 48: Wire wrapped around cable to keep it from moving around

6.3.2 Pin Retainer System Assembly

Refer to assembly drawing TH2010 when assembling the pin retainer system. Figure 49 shows the physical parts laid out and labeled “SHCS” is an acronym for Socket Head Cap Screw.

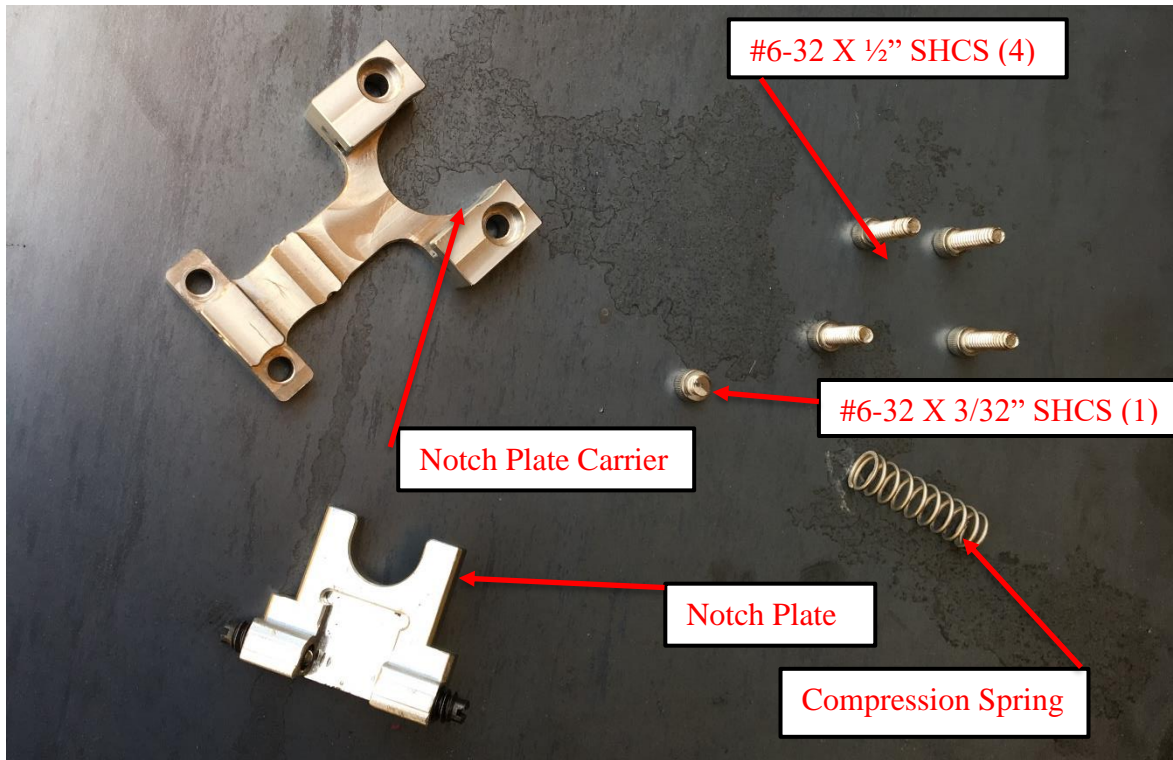


Figure 49: Components necessary to assemble the pin retainer system.

Figure 50 shows how to install the notch plate within the notch plate carrier. Some resistance will be encountered as the ball detents slide past the indentations in the notch plate carrier.

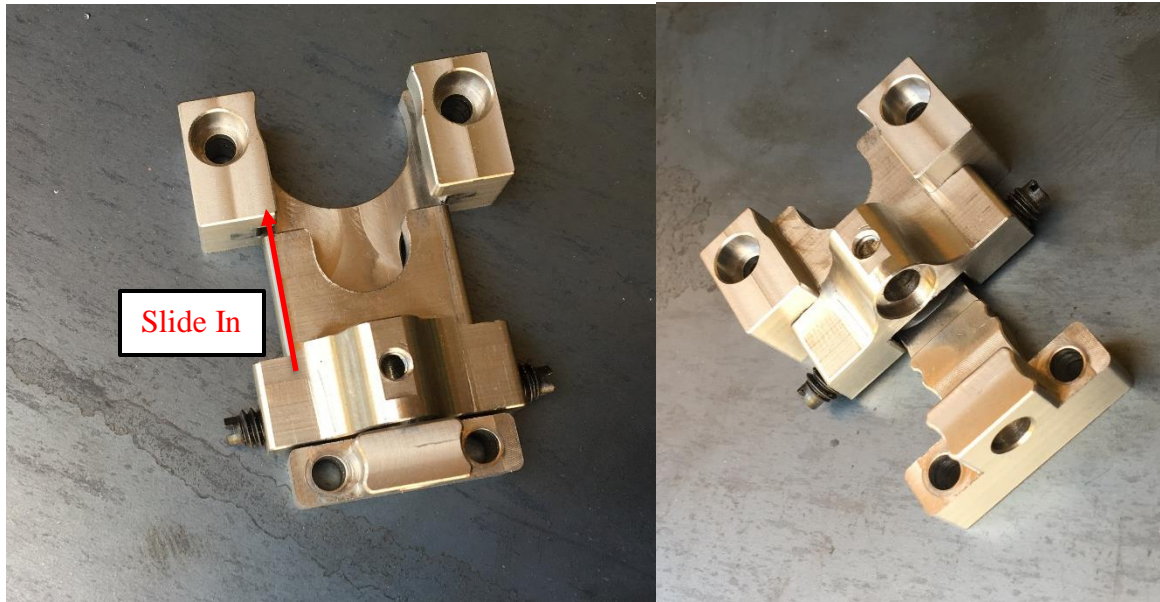


Figure 50: Locating to notch plate within the notch plate carrier

When inserting the compression spring as shown in Figure 51: Properly locating the compression spring to retain the notch plate within the notch plate carrier. Figure 51, seat the spring in the bore of the notch plate carrier first, and then compress it by hand and seat it in the notch plate.

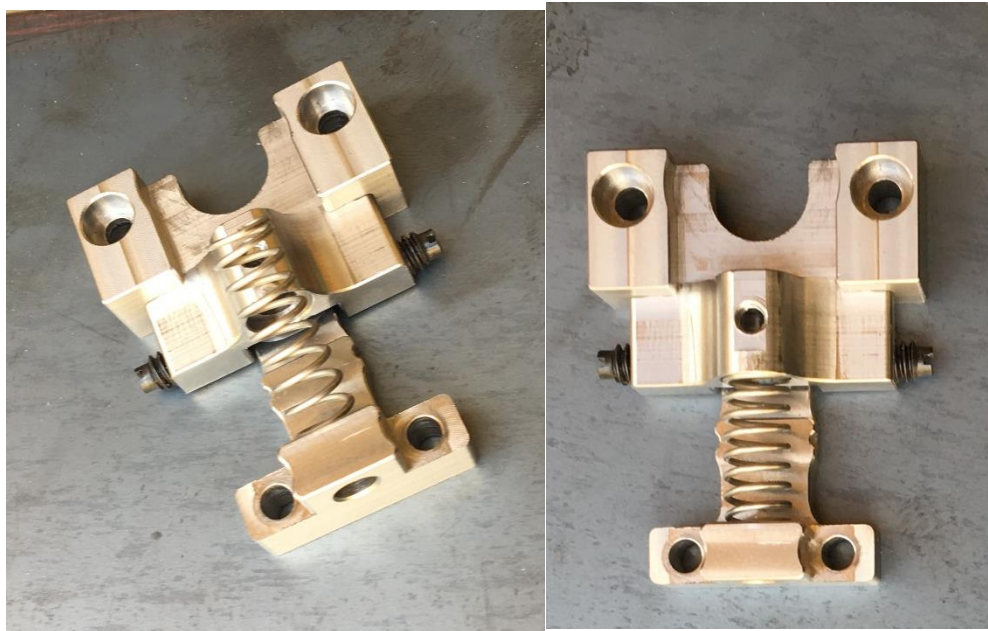


Figure 51: Properly locating the compression spring to retain the notch plate within the notch plate carrier

The pull handle is fastened using a short SHCS which interlocks with a groove. Snug the screw with the allen wrench as shown in Figure 52. Do not over tighten.

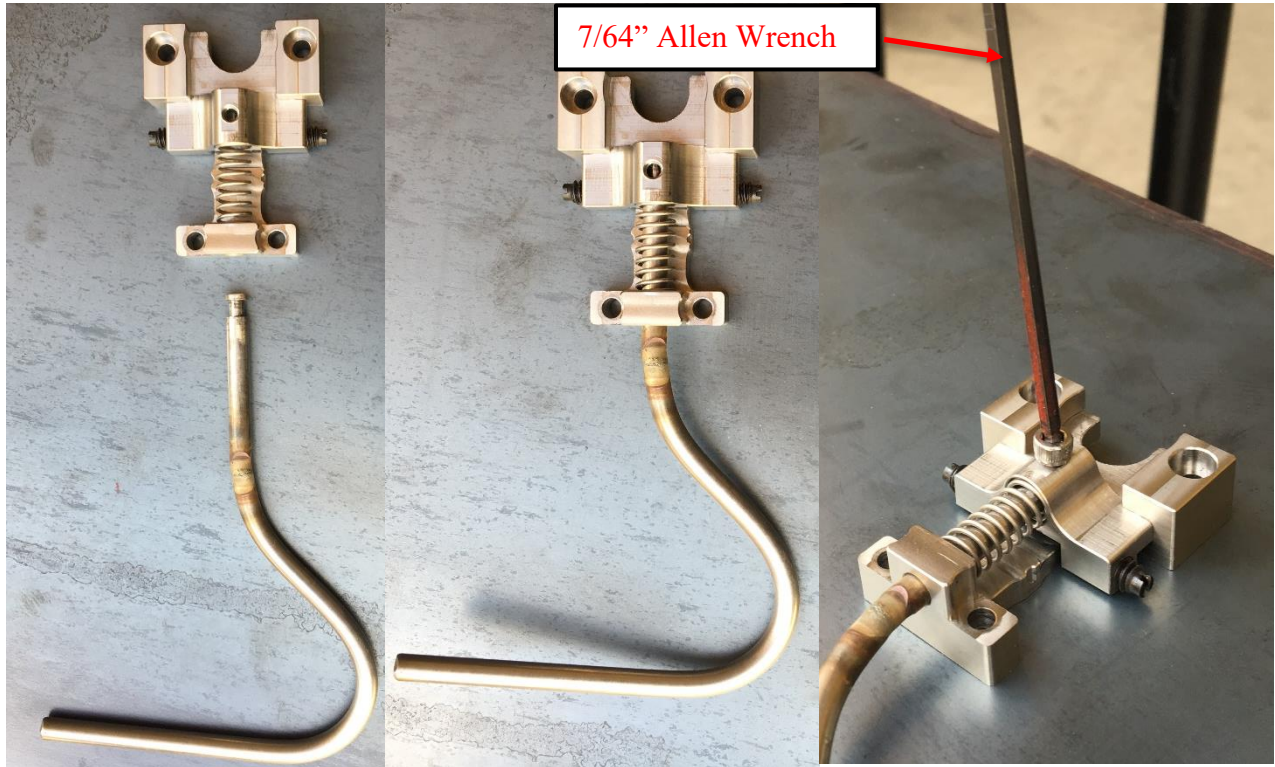


Figure 52: Installing the pull handle

When attaching the pin retainer system to receiver, use the four SHCS as shown in Figure 53. Tighten the screws gently using the allen wrench, being sure not to over-tighten.

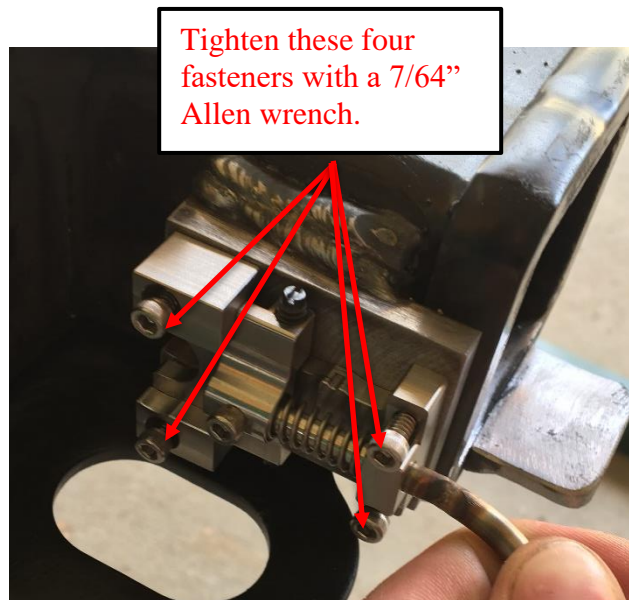


Figure 53: Installing the pin retainer system on the hitch receiver

6.3.3 Electrical Receptacle Assembly

- Disassemble electrical receptacle and remove torsional spring
- Epoxy Neodymium magnets into cage pockets



Figure 54: Neodymium magnets in the receptacle cage

- Glue down the electrical receptacle cages to the doors (while disassembled).
- Reassemble electrical receptacle without torsional spring.

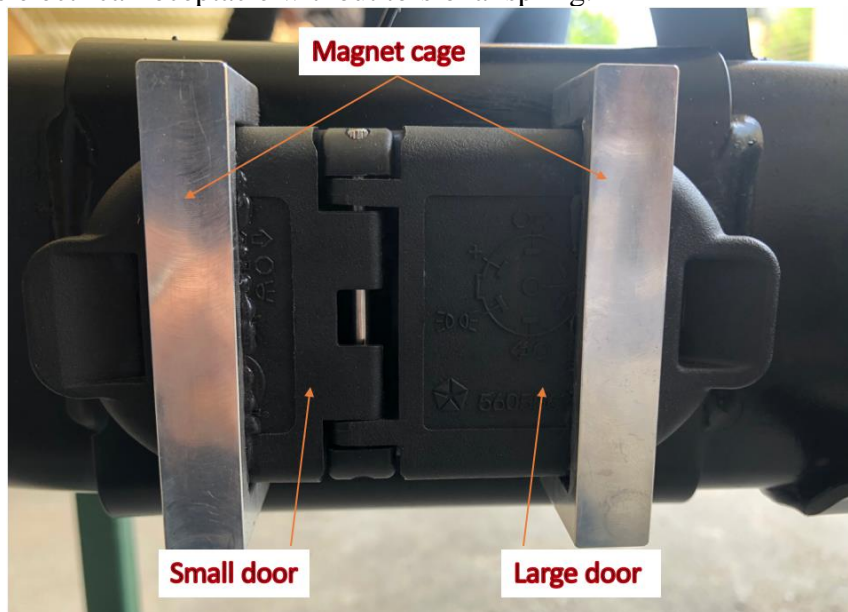


Figure 55: Electrical receptacle with the cage attached

- Snap the electrical receptacle into the OEM Jeep receiver in the correct orientation

6.3.4 Tongue Lever Assembly

- Epoxy the pads to the interior side of the flanges and neoprene to the Coupler body
- Use fasteners to attach the flanges to the body of the lever

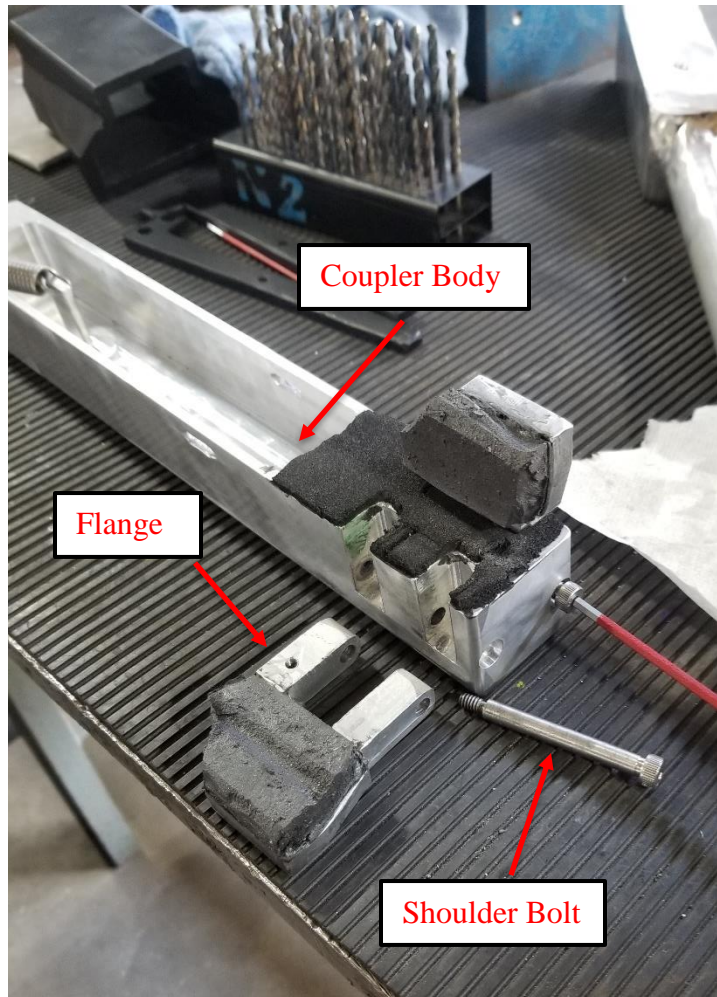


Figure 56: Flange-Coupler Body Connection.

- Use fasteners to attach the wings to the flanges.
- To install the internal spring system in tension be sure to that you have adequate excess steel cord crimp a bead on one end of the cord. Feed the other end of the cord through one wing, through the slot in the side of the coupler body, through the end of the tension spring and through the body and wing on the other side. Thread another crimping bead onto the end of the cord. Pull the cord until the spring is expanded then have another person crimp the bead close to the coupler body. Cut off the excess cord and sand down the frayed ends.

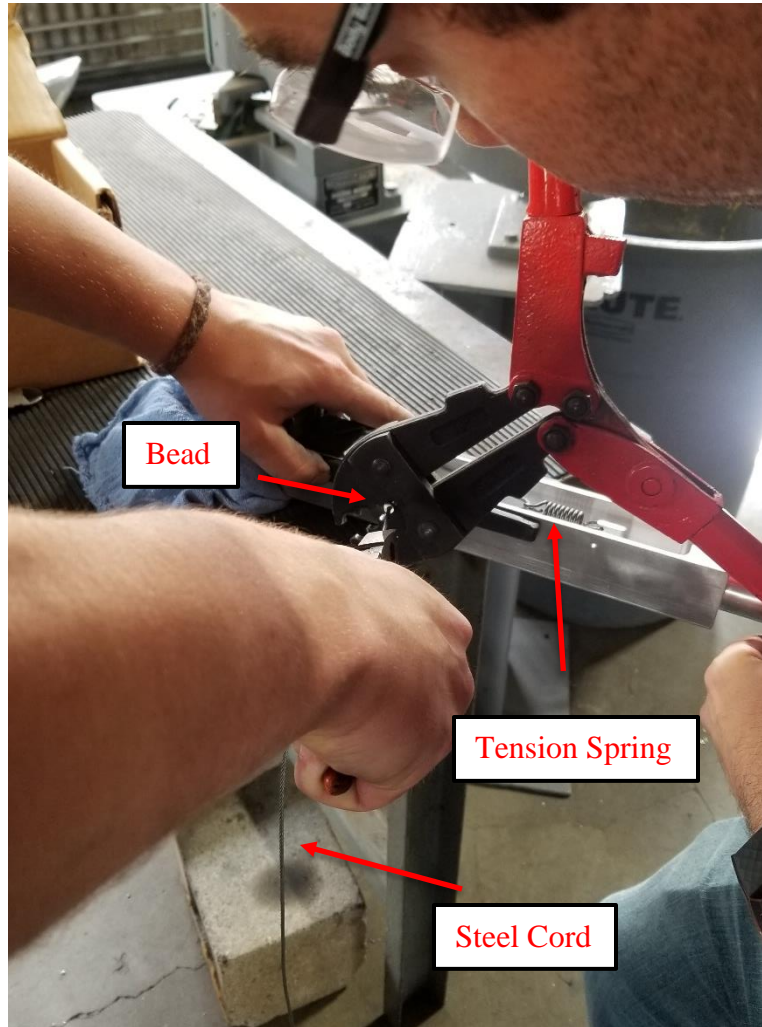


Figure 57: Crimping the bead with the spring in tension.

- Put fasteners through the holes in the bottom of the collar and screw them into the incline.



Figure 58: Securing the Incline to the Collar.

- Slide collar onto the coupler lever body and secure the set screw into the body behind it so that the collar cannot slide off.

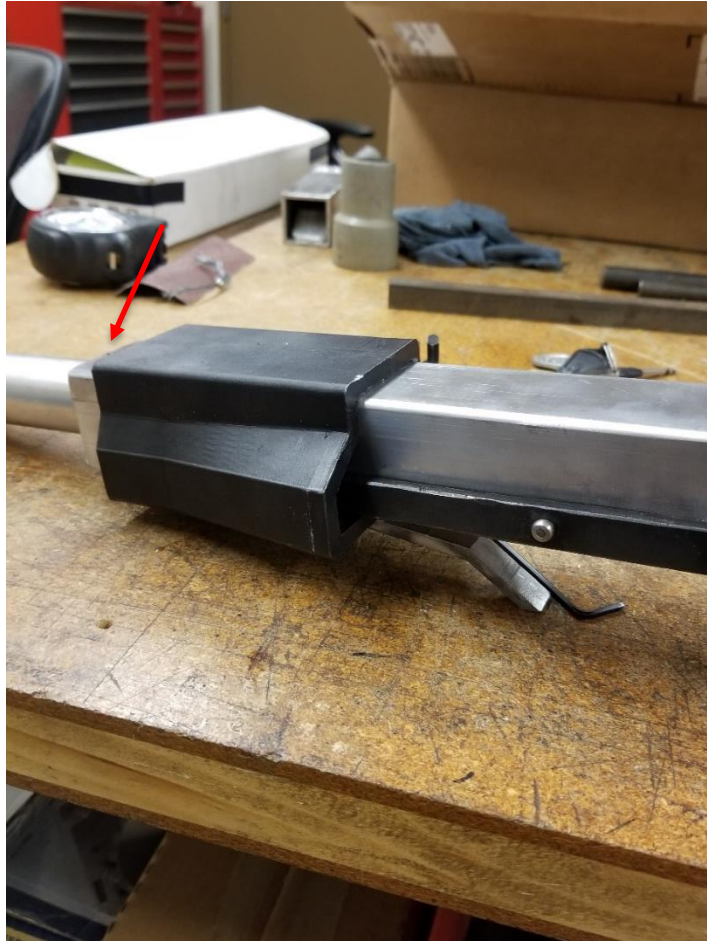


Figure 59: Securing the Incline to the Collar.

7 DESIGN VERIFICATION

7.1 TESTING

Testing has been carried out using our fabricated test stand which supports the OEM Jeep hitch receiver as if it were mounted to the vehicle. We made this stand in the workshop with 1.5” steel square tubing. Drawings and designs of this weldment are not included in this report because it is not part of the final product that will be sent to Taylor. Refer to Appendix G: Design Verification Plan for a DVP spreadsheet.



Figure 60: OEM Jeep hitch receiver mounted to receiver test stand.

7.1.1 Timed Test/Oven-Mitt Test

Although originally considered as two separate tests, it was realized during testing that the timed test and the Oven-Mitt test can be combined. The oven mitt test had the intent of verifying the functionality of the design with minimal dexterity. Satisfactory completion of the timed test implies satisfactory completion of the Oven Mitt test, as the design could not pass the timed test without meeting dexterity requirements.

To ensure that the tri-ball hitch can be extended and rotated by Taylor, we went through the whole trailer hitching process using only one hand with an oven mitt on. This simulated Taylor’s motor ability. In order to verify Taylor could perform these functions we had a video conference with him while we performed the testing. Taylor had some feedback about how the hooks attached, but overall liked how simple our design is. To find the approximated hitching time we gave each team member three trials and then averaged all our time trials.

Table 2: Timed hitch up trial data

Max C	Trial 1	Trial 2	Trial 3	Mean
Time (s)	39.03	39.06	33.66	37.25
Max S	Trial 1	Trial 2	Trial 3	Mean
Time (s)	36.08	1:02.33	43.45	39.765
Eric R	Trial 1	Trial 2	Trial 3	Mean
Time (s)	46.88	38.32	46.83	44.01
Joe H	Trial 1	Trial 2	Trial 3	Mean
Time (s)	39.43	1:09.85	54.15	46.79

7.1.2 Corrosion Resistance Test

To simulate rough road conditions and harsh weather, we dumped a saltwater solution on the entire assembly. We then waited four days and proceeded through the entire hitching process multiple times while looking for potential issues like rust spots, paint chips, or collections of debris in critical areas. After the test, none of the systems were impaired at all, there was some surface rust in non-critical areas and some salt residue that can be seen in Figure 61. Based on the amount of rust we saw during this test we determined that our functions were weatherproof.

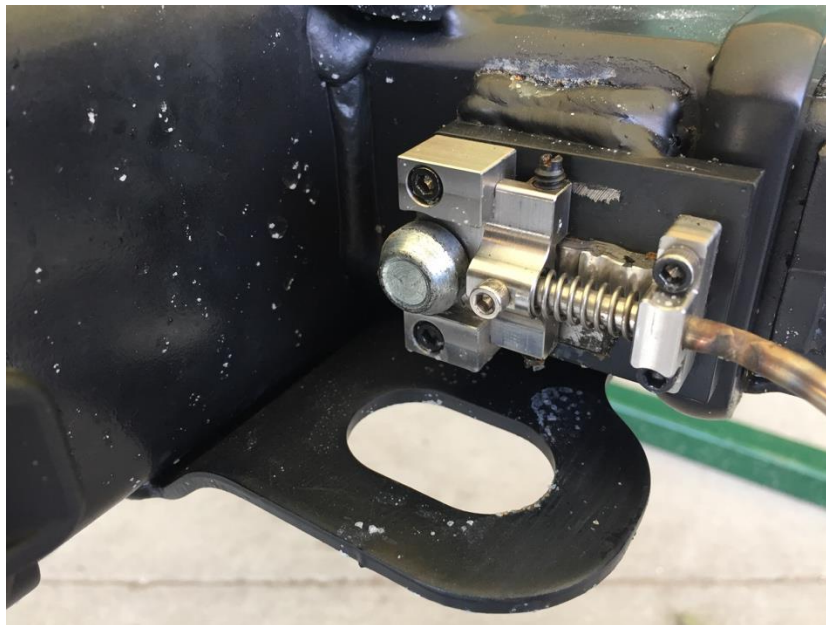


Figure 61: Saltwater residue on hitch pin mechanism, four days after corrosion test

7.1.3 Force Tests

To determine the forces required to use our system, we purchased a push/pull force gauge for our testing that has a capacity of 44 lb_f, exceeding the maximum allowable force of 25 lb_f. The gauge was used to test the following actions: pulling out the tri ball, rotating the tri ball, pulling handle to release pin, opening electrical connection doors, and activating tongue lever. In these tests we collected multiple data points for each function and performed statistical analysis to make sure the statistical range of the data remains below the maximum force. The collected data can be seen in Table 3, and the statistical analysis is summarized in Table 4.

Table 3: Force data collected for the various operations in using the system.

Hitch Rotation	Trial 1	Trial 2	Trial 3	Trial 4	Trial 5	Mean [N]	Mean [lbf]
1 (out) [N]	60.0	70.0	47.0	52.0	53.0	56.4	12.7
2 (rotation) [N]	38.0	40.0	62.0	31.0	90.0	52.2	11.7
3 (back in) [N]	40.0	49.0	53.0	50.0	42.0	46.8	10.5
Pin Retainer	Trial 1	Trial 2	Trial 3	Trial 4	Trial 5		
1 (remove pin) [N]	5.00	5.00	5.00	5.00	5.00	5.00	1.12
2 (pull handle) [N]	60.0	60.0	52.0	62.0	63.0	59.4	13.4
3 (bump handle) [N]	4.00	9.00	7.00	7.00	8.00	7.00	1.57
Electrical Receptacle	Trial 1	Trial 2	Trial 3	Trial 4	Trial 5		
1 (open door) [N]	6.00	5.00	6.00	4.00	6.00	5.40	1.21
Coupler Lever (A)	Trial 1	Trial 2	Trial 3	Trial 4	Trial 5		
1 (Push down) [N]	130.	130.	95.0	90.0	90.0	107.	24.1
2 (clamp) [N]	70.0	80.0	80.0	60.0	120.	82.0	18.4
3 (unlock) [N]	8.00	8.00	8.00	8.00	8.00	8.00	1.80
Coupler Lever (B)	Trial 1	Trial 2	Trial 3	Trial 4	Trial 5		
1 (Slide On) [N]	50.0	80.0	100.	98.0	60.0	77.6	17.45
2 (lock) [N]	4.00	4.00	4.00	4.00	4.00	4.00	0.899
3 (unlock) [N]	7.00	8.00	8.00	7.00	7.00	7.40	1.66

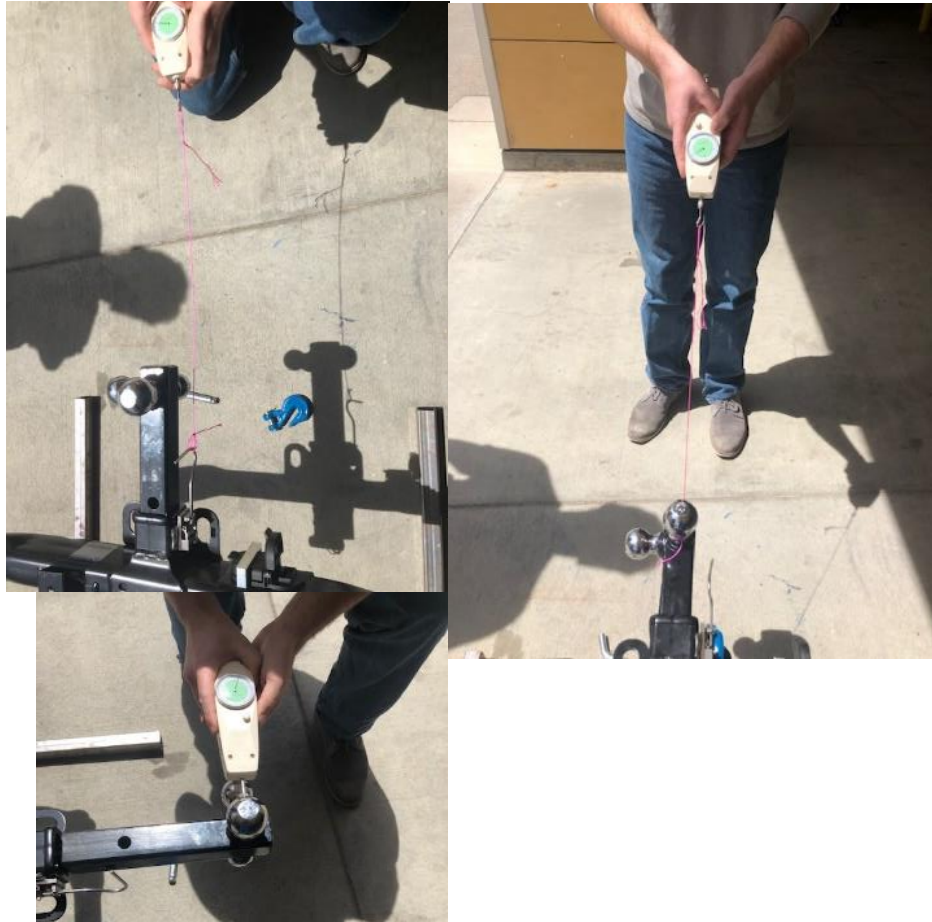


Figure 62: Sample photos from the force test.

7.1.3.1 Force Test Statistical Analysis

Table 4 shows the mean, standard deviation, and 95% confidence interval for each of the movements in the force test. No sensible test could be designed for this project which involved uncertainty propagation analysis, so this analysis uses the 95% confidence interval to determine an expected range of force values for each of the motions under normal conditions. To account for the uncertainty in the measurement instrument (the force gauge), the amplitude of the 95% confidence interval was combined with the worst-case measurement error using RSS (root sum-square). The “Expected Range” in Table 4 is determined by taking a range around the mean of each data set with an amplitude of the RSS combination.

Table 4: Force test distributions data

Hitch Rotation	Mean [lbf]	Std. Deviation [lbf]	95% Conf. Interval [lbf]	Expected Range [lbf]
1 (out)	12.7	2.00	10.18-15.14	10.18-15.14
2 (rotation)	11.7	5.41	5.00-18.4	5.00-18.4
3 (back in)	10.5	1.25	8.96-12.1	8.96-12.1
Pin Retainer				
1 (remove pin)	1.12	0.000	1.12-1.12	1.07-1.18
2 (pull handle)	13.4	0.973	12.13-14.54	12.13-14.54
3 (bump handle)	1.57	0.420	1.05-2.09	1.05-2.10
Electrical Receptacle				
1 (open door)	1.21	0.201	0.963-1.46	0.957-1.47
Coupler Lever (A)				
1 (Push down) [N]	24.0	4.74	18.1-29.9	18.1-29.9
2 (clamp) [N]	18.4	5.12	12.0-24.8	12.0-24.8
3 (unlock) [N]	1.80	0.000	1.80-1.80	1.74-1.85
Coupler Lever (B)				
1 (Slide On) [N]	17.45	5.01	11.2-23.6	11.2-23.6
2 (lock) [N]	0.898	0.000	0.898-0.898	0.842-0.954
3 (unlock) [N]	1.66	0.123	1.51-1.81	1.50-1.82

7.1.3.2 Force Test Conclusions

After performing these tests (see Table 3), we found that only one of our loads exceed the 25 lbf limit in our specifications table. The largest force that is expected is 29.9 lbf and is for pushing the Coupler lever (A) onto the trailer coupler. Although this does not meet the force specification, the comparable test for Coupler Lever (B) does, with a maximum expected force of 23.6 lbf. This shows that our design requires reasonable input forces that will likely not strain or damage a prosthetic limb and that it passed the force test. With some tuning and optimization, Coupler Lever (A) could be made to meet the specifications.

7.1.4 Pinch points

Another potential issue in the design is pinch points, which could potentially injure the user. This issue can be evaluated by inspection. We operated the device many times with our bare hands

and did not find any significant pinch points. Although we did not experience issues with any of these hazards ourselves, potential pinch points have been identified in the operator's manual to promote user awareness of safety.

8 PROJECT MANAGEMENT

8.1 DESIGN PROCESS

The process we have used to develop a design for this problem had 5 main phases. These phases were problem definition, conceptualization, detail design, manufacturing, and testing.

8.1.1 Problem Definition

In the problem definition phase, we interviewed our sponsor and customers to determine their needs and wants, and what resources they could provide for the project. These resources included funding and experience with similar challenges. We also performed product and technical research to determine if there were existing solutions to our problem and identify standards that our design must meet. The problem was further refined as these three research categories were performed. If the project were to be carried out again, it would be beneficial to start this stage earlier with more time buffer before deliverables are due. The problem definition phase was of educational benefit to our project management and communication skills. We were less proactive than would have been optimal when communicating with our challenger.

8.1.2 Conceptualization

In the conceptualization phase, we took the results of our research and problem definition and used them to generate ideas for potential solutions. Various brainstorming techniques, such as brain writing, and SCAMPER were used to generate lots of ideas very quickly. Concept models were also used in this phase to visualize concepts. We then chose and further refined concepts in CAD models and did preliminary calculations to determine the feasibility of the potential designs. This was all to prepare for concept prototyping; it was our goal to have a decent prototype of one promising concept by the end of the first quarter.

8.1.3 Detail Design

The second quarter of senior design project marked the beginning of the truly detailed design that we performed. The project was broken into five main subsystems, four of which required intensive design. At this point, we decided on a final design and proceeded with detailed CAD that included critical dimensions and tolerancing. We also performed stress analysis and FEA on our design to ensure components were sized properly. Interim design review took place before critical design review and provided an opportunity to change and improve the design before critical design review. During this phase, we had communication issues with our challenger, Taylor. These issues resulted from our failure to follow up promptly when we needed information from him. We mainly needed dimensions of the trailer couplers that Taylor uses on his trailers; without the information we were ineffective at designing a practical coupler lever that would operate the trailer couplers effectively. This hiccup in the design process was a good lesson that will be useful later in our careers when we are designing products for clients on a tight schedule; it is important to communicate with the customer early and often, especially when

things are behind schedule. Regarding scheduling, it would have helped to be more thoughtful in our scheduling process and to adhere to the predetermined schedule as much as possible. This ensures that the buffer time built into the schedule is preserved for unforeseen circumstances.

8.1.4 Manufacturing

Once our device was designed, we entered the manufacturing phase of the project in the third quarter. All machining and assembly took place in the Mechanical Engineering Student Shops (Mustang '60 and Aero Hangar). While some of our parts were manufactured early in the 2nd quarter (such as the test stand for our hitch receiver), we still needed to make many of the other components during quarter 3. Each team member manufactured the components for the subsystem that they designed.

8.1.5 Testing

Testing was the last main phase that the project underwent before the senior project expo at the end of May. A test stand was fabricated in the 2nd quarter to support the receiver and facilitate testing. We previously identified four main tests to evaluate the prototype against our predetermined engineering specifications. The tests were relatively simple in that they did not require special facilities and equipment. Procedures were written for each test early in the third quarter to ensure safe and consistent testing was carried out. This ensures the test data is sensible and the risk of injury/damage to equipment is low. Our test stand was set up in the yard of the machine shop and was been used in every test. Our tests ensured that our system functioned as planned (force tests) and The testing phase also involved our challenger, Taylor, when we used FaceTime to show him all functions of the device and verified that he is capable of doing them. We were happy to receive his confidence of being able to perform all actions. He also gave feedback on a few small things that could be improved (such as the attachment of safety chains). To improve attachment of the safety chains, we ground the sharp edges off the attachment points to reduce snagging of the hooks. He expressed concern about storage of the hitch pin during use, as he must set it somewhere. A small perch was added to the hitch receiver where the pin can be placed and easily gripped once again. This will hold the pin when it is removed so Taylor does not have to pick it up off the ground.

8.2 KEY ACTIVITIES AND MILESTONES

Table 2 below gives an overview of deadlines that were met to complete this project successfully.

Table 5: Key activities and milestones

Key Deliverables	Due Date
Manufacturing/Test Review	3/14/19
Assembly	4/23/19
Testing	5/16/19
Final Design Review	5/30/19
Project Expo	5/31/19

8.3 GANTT CHART WITH TIMELINE

This project spans several months and has key deliverables for each design phase that we delivered on the dates outlined in Table 5 above. In order to visualize the project plan and keep all team members up to date, we constructed a Gantt chart using TeamGantt. With this chart, project events can be planned in sequence and based on projected time requirements. The Gantt chart has been filled with all tasks completed for this project and is located in Appendix B: Gantt Chart.

9 CONCLUSION

The adapted trailer hitching system is a significant evolution from the original ideas for the trailer hitch project. The design process began with customer research and product research; the customer research revealed the wants and needs of the challenger and the product research provided a baseline from which to move forward with our modifications. Initially, our challenger (Taylor Morris) wanted a trailer hitching system that did not require the user to exit the vehicle during use; it would grip the trailer and locate the trailer coupler over the trailer hitch automatically. Considering the timeline of the project, we decided to propose a simpler design. We chose a design that adds devices to standard trailer hardware to make it easier to use, rather than designing fully custom devices that would require special certifications. Taylor was understanding of our decision given the timeframe of this project.

During the first quarter, we built concept models that provided good direction to the project. Our concept design initially had a “black box” device which was intended to be used over the trailer coupler to lower the trailer on to the tri-ball hitch and actuate the coupler mechanism. This proved to be a difficult mechanism to design with the variety of trailer configurations that exist. As a result, our project scope was further reduced to mostly the vehicle side of the interface. Our final design was mostly completed by the end of the 2nd quarter and consisted of a customized

pin retaining system, a modified electrical receptacle with a door that remains open until pushed closed, a rotating mechanism for the triple ball hitch, and a customized lever for using the trailer coupler.

If this project were to be done over, more attention and consideration would be dedicated to the design of an effective coupler lever. As a team, we had communication issues with Taylor that were a result of our failure to reach out soon enough and follow up promptly when we had questions. Many days during the 2nd quarter of the project, one or more team members made little design progress as a result of the communication issues. This inefficient use of time placed our team on a tight schedule in the third quarter, resulting in less analysis and refinement than would have been optimal. The coupler lever could have been designed, prototyped earlier and refined to meet the predetermined project specifications. Unfortunately, coupler lever design A does not meet the force specification of 25lb_f max. The possibility that the initial coupler lever design would not meet the specifications was considered prior to its completion, since little analysis was performed to develop a baseline of its functionality. A back-up coupler lever was built that would likely meet the design specifications and would be simple to manufacture. This coupler lever meets the force specification but only works for one style of trailer coupler and is not adaptable to other trailer coupler designs. This is satisfactory for Taylor's requirements, but we would have liked to make version A (the more adaptable one) work well enough to satisfy all design specifications and be feasible to use. Aside from the few set-backs mentioned above, we are happy to hear that Taylor is satisfied with our designs and appreciates our focus on keeping the solutions simple. We know that in order for this system to work reliably for many years in an outdoor environment the functions need to be simple and robust.

9.1 NEXT STEPS

Moving forward, there are a few things that need further refinement to fully optimize the functionality of the trailer hitching system. This primarily includes the coupler lever, which technically meets the specifications, but has not been critiqued by Taylor. In using the device, it seems that it will be difficult to operate with one prosthetic arm, since many of the motions require rotating one's wrist and gripping wide. In addition to the coupler lever, the safety chain hooks need to be field tested to ensure that they will stay attached without safety latches. Hooks were chosen without the safety latches to make them easier to remove when disconnecting the trailer from the vehicle.

10 REFERENCES

- [1] “Curt Switch Ball Sets.” StackPath, www.curtmfg.com/towing-accessories/trailer-balls/switch/sets.
- [2] “Automated Attachment System for Bumper Pull Trailers.” Innovative Towing Systems, Inc., 11 Nov. 2014, www.safetyhitch2.com/the-automated-safety-hitch/automated-attachment-system-for-bumper-pull-trailers/.
- [3] “B&W TS10048B Tow & Stow®.” Tow & Stow® | B&W Trailer Hitches, bwtrailerhitches.com/product/tow-stow.
- [4] “Ultra-Tow 12 Volt Swivel Electric Trailer Jack” Northern Tools, www.northerntool.com/shop/tools/product_200685145_200685145?cm_mmc=Google-pla&utm_source=Google_PLA&utm_medium=Trailers%2B%2B%2BTowing%2B%3E%2BTrailer%2BJacks&utm_campaign=UltraTow&utm_content=57406&gclid=CjwKCAjw3qDeBRBkEiwAsqeO7sORY0r1drjUzQCxKok9Emw6_or1NDkwIIPbqcyJ6fz6cY2Wt3thoCZM0QAvD_BwE.
- [5] “Trailer Ball Mount Hitches.” Trailer & Towing | Trailer Ball Mount Hitches | All States Ag Parts, www.tractorpartsasap.com/farm-shop-supplies/trailer-towing/trailer-ball-mount-hitches.html.
- [6] Phares, Benny E, and Ronald R Marthaler. Rotating Multiple Ball Trailer Hitch. 1 Oct. 1996.
- [7] Janeiro, Joseph. Interchangeable Towing Ball Assembly. 2 Feb. 1992.
- [8] Moss, Newell, Bowers, Jack and H. Wing. Monolithic, double-ball hitch. 24 Oct. 2006.
- [9] Brown, Clifford. <https://Patents.google.com/Patent/US6779616>. 24 Feb. 2004.
- [10] Gill, George P. Folding Ball Hitch with Recessed Safety Chain Attachment. 4 Aug. 1998.
- [11] Ringsrud, Eric. Team Hitch Boundary Diagram. 2018, Cal Poly.
- [12] “MOPAR 7-Way and 4-Way Trailer Harness Connector by Mopar.” Jeep Knowledge Center, www.morris4x4center.com/mopar-7-way-trailer-harness-connector-56055632ac-m.html?gclid=CjwKCAjwyOreBRAYEiwAR2mSktnl3OQBz7LXWAdoEK2b6mYdjMFeqWGNiBn8c1q4-uEYQDXvQR4KGBocdlYQAvD_BwE&gclsrc=aw.ds
- [13] “Hitch Receiver.” Mopar CAP | Official Mopar Site, www.mopar.com/en-us/store/accessories/product/82212180AC/Hitch+Receiver.html.
- [14] “Triple Ball Trailer Hitch.” Harbor Freight Tools, www.harborfreight.com/triple-ball-trailer-hitch-61914.html.

[15] "5/8 In. x 3 in. Hitch Pin with Clip." Harbor Freight Tools, www.harborfreight.com/5-8-eighth-inch-x-3-inch-hitch-pin-with-clip-65432.html.

[16] SAE International. "Trailer Couplings, Hitches, and Safety Chains—Automotive Type (J684 Ground Vehicle Standard) - SAE Mobilus." SAE MOBILUS, 30 May 2014, saemobilus.sae.org/content/J684_201405/. Accessed 14 Nov. 2018.

11 APPENDIX A: HOUSE OF QUALITY

Correlations
 Positive +
 Negative -
 No Correlation

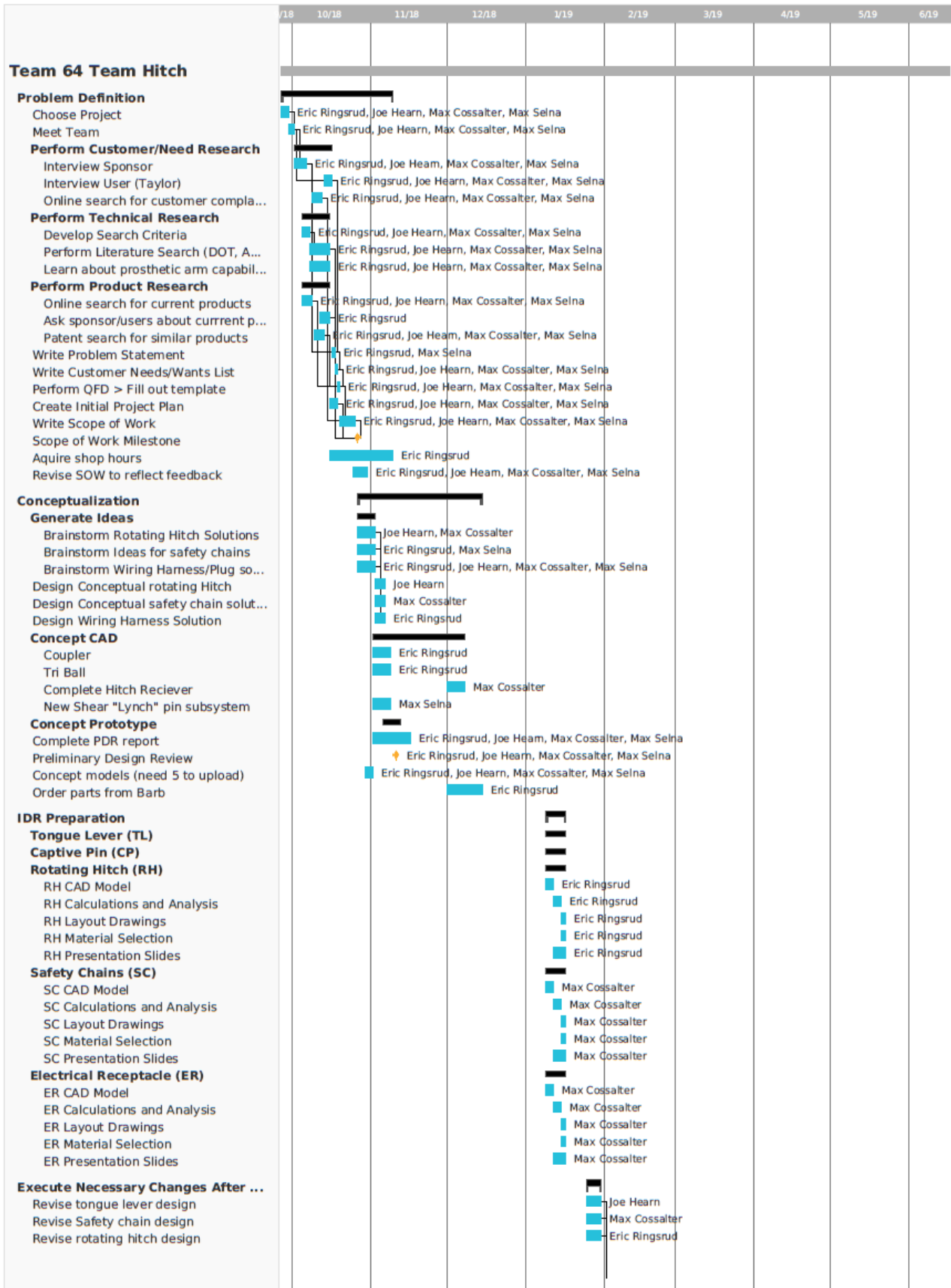
QFD House of Quality
 Project: Trailer hitch
 Revision Date: 10/11/2018

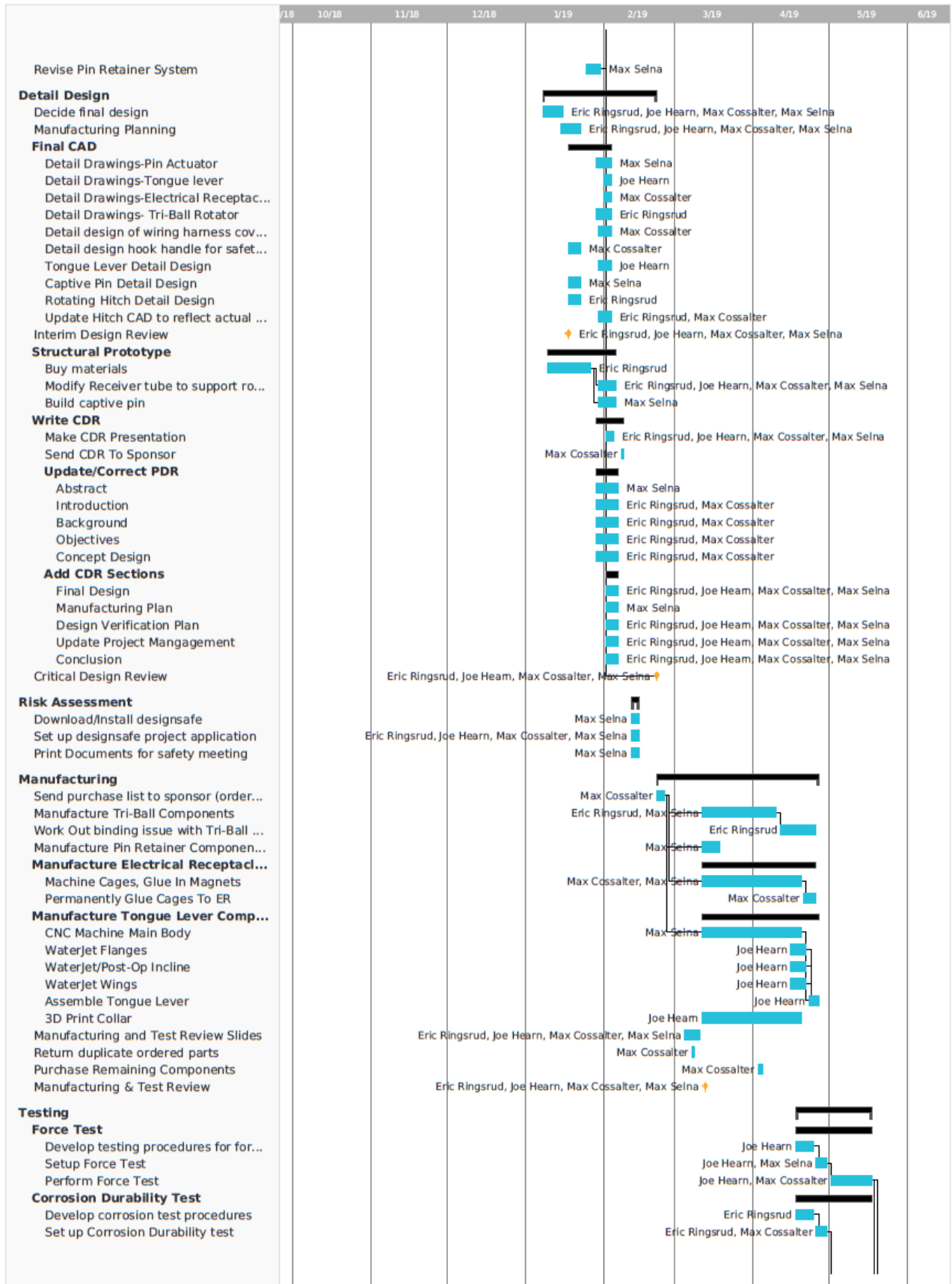
Relationships
 Strong ●
 Moderate ○
 Weak ▽

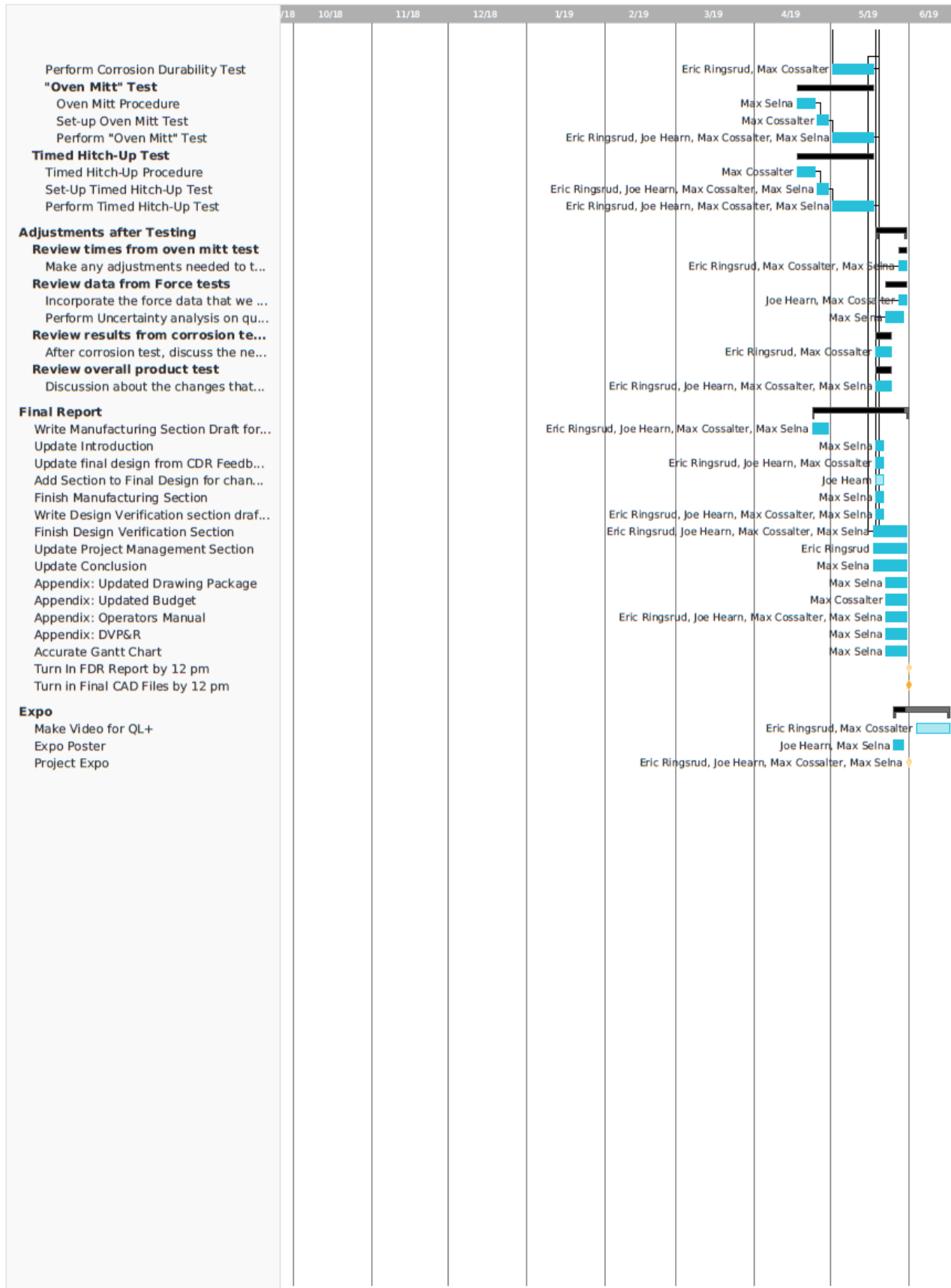
Direction of Improvement
 Maximize ▲
 Target ◇
 Minimize ▼

Row #	WHQ: Customers					WHAT: Customer Requirements (Needs/Wants)	HOW: Engineering Specifications (Tests)																NOW: Curr. Products				Row #											
	Weight Chart	Relative Weight	Taylor Morris	Lance Lunker	People with Disabilities		Current Trailer Users	Maximum Relationship	Column #	1	2	3	4	5	6	7	8	9	10	11	12	13	14	15	16													
1	8	8	9	8	8	9	Safe To Use		○	○	○	▽	▽	▽	▽	○	○														4	4	5	5				
2	9	8	9	7	9	9	Simple		▽	▽	○	○	○	○	○	○	○														3	4	4	3				
3	7	7	6	8	9	9	Durable		▽	○	○	○	○	○	○	○															5	4	4	4				
4	7	8	6	8	8	9	Weatherproof		▽	○	○	○	○	○	○	○															3	3	4	2				
5	6	8	5	8	9	9	Looks Nice		▽	▽	▽	▽	○	○	○															4	3	5	3					
6																																						
7	4	5	8	8	8	9	Reasonable Cost to replicate		▽	▽	▽	○	○	○	○	●														4	3	3	1					
8	9	8	8	6	6	9	Easy To Use		●	▽	○	○	○	○	○	○														1	4	5	5					
9																																						
10																																						
HOW MUCH: Target Values							requires no force >15 lbs	9	9	9	9	9	9	9	9	9																						
Technical Importance Rating							meets standards																															
Relative Weight							yes																															
Max Relationship							no pinch points	9	9	9	9	9	9	9	9	9																						
Curr. Products							very resistant																															
							dark colors and chrome																															
							<\$500																															

12 APPENDIX B: GANTT CHART







13 APPENDIX C: DESIGN HAZARDS CHECKLIST

DESIGN HAZARD CHECKLIST

Team: **Hitch** Advisor: **Rossman** Date: **11/14/2018**

YN

- 1. Will the system include hazardous revolving, running, rolling, or mixing actions?
- 2. Will the system include hazardous reciprocating, shearing, punching, pressing, squeezing, drawing, or cutting actions?
- 3. Will any part of the design undergo high accelerations/decelerations?
- 4. Will the system have any large (>5 kg) moving masses or large (>250 N) forces?
- 5. Could the system produce a projectile?
- 6. Could the system fall (due to gravity), creating injury?
- 7. Will a user be exposed to overhanging weights as part of the design?
- 8. Will the system have any burrs, sharp edges, shear points, or pinch points?
- 9. Will any part of the electrical systems not be grounded?
- 10. Will there be any large batteries (over 30 V)?
- 11. Will there be any exposed electrical connections in the system (over 40 V)?
- 12. Will there be any stored energy in the system such as flywheels, hanging weights or pressurized fluids/gases?
- 13. Will there be any explosive or flammable liquids, gases, or small particle fuel as part of the system?
- 14. Will the user be required to exert any abnormal effort or experience any abnormal physical posture during the use of the design?
- 15. Will there be any materials known to be hazardous to humans involved in either the design or its manufacturing?
- 16. Could the system generate high levels (>90 dBA) of noise?
- 17. Will the device/system be exposed to extreme environmental conditions such as fog, humidity, or cold/high temperatures, during normal use?
- 18. Is it possible for the system to be used in an unsafe manner?
- 19. For powered systems, is there an emergency stop button?
- 20. Will there be any other potential hazards not listed above? If yes, please explain on reverse.

For any “Y” responses, add (1) a complete description, (2) a list of corrective actions to be taken, and (3) date to be completed on the reverse side.

Description of Hazard	Planned Corrective Action	Planned Date	Actual Date
The triple ball hitch will be cantilevered out of the receiver tube when it is being rotated. This is not terribly dangerous; the hitch will be constrained from falling off the spindle.	Design the spindle with a conservative factor of safety against (1) separation from the receiver and (2) fatigue failure due to bending moment on the spindle when the tri ball is cantilevered out.	Dec-Jan '19	Jan '19
The system will be exposed to cold weather and salted roads, as well as snow and ice.	The system will be designed with weather resistance in mind. Sliding and precise metal components will be made of corrosion resistant materials such as stainless steel.	Mar-May '19	Apr '19
The system can be used in an unsafe manner, if the pin is not properly inserted, or the tongue lever is used improperly as to impose a slip hazard.	Implement detailed instructions and warning labels on the hardware to ensure it is used safely and properly.	Mar-Apr '19	Apr '19

14 APPENDIX D: PROJECT BUDGET

Notes:

- Each purchase part # doubles as a hyperlink to product literature.

Table 6: Procurement Information for Adapted Trailer Hitch Confirmation Prototype

Description	Vendor	Vendor Part#	Dependent BOM Part#	Purchase Method	Purchase Date	Received date	Total Cost
Rare Earth Magnets	McMaster Carr	7048T24	7048T24	By Sponsor	2/26/19	2/26/19	\$23.22
Safety Chain Hooks	Amazon	Temco TH0047	Temco TH0047	By Sponsor	2/26/19	2/26/19	\$60.54
6061 Aluminum Bar	McMaster Carr	9008K51	TH 3031, TH 3051	By Sponsor	2/26/19	2/26/19	\$50.68
6061 Aluminum Bar	McMaster Carr	8975K513	TH 3041, TH 3043	By Sponsor	2/26/19	2/26/19	\$29.13
Low-Carbon Steel Bar	McMaster Carr	8910K551	TH 3042, TH 3044	By Sponsor	2/26/19	2/26/19	\$12.65
3/32" Wire Rope	McMaster Carr	3332T51	TH 3002	By Sponsor	2/26/19	2/26/19	\$7.70
3/32" Wire Rope Compression Sleeve	McMaster Carr	3896T32	3896T32	By Sponsor	2/26/19	2/26/19	\$8.41
303 SS Bar	McMaster Carr	9084k68	TH 3011, TH 3012	By Sponsor	2/26/19	2/26/19	\$32.62
Mopar Electrical Plug	Morris 4x4	56055632AC-M	56055632AC-M	By Sponsor	12/13/18	1/8/19	\$99.98
OEM Jeep Hitch Receiver	Mopar	82212180AC	82212180AC	By Sponsor	12/13/18	1/22/19	\$262.00
Tri-Ball	Harbor Freight	Haul Master 61914	Haul Master 61914	By Sponsor	12/13/18	1/8/19	\$33.99
6-32 SHCS	McMaster Carr	92196A148	92196A148	By Sponsor	1/22/19	1/30/19	\$5.41
3/16" Stainless Rod	McMaster Carr	89535K84	TH 3014	By Sponsor	1/22/19	1/30/19	\$5.36
Grooved Hitch Pin	Amazon	Tow Ready 63240	Tow Ready 63240	By Sponsor	1/22/19	2/4/19	\$8.95
10-24 Ball Detents	McMaster Carr	3408A521	3408A521	By Sponsor	1/22/19	1/30/19	\$18.48

Compression Springs	McMaster Carr	9435K61	9435K61	By Sponsor	1/22/19	1/30/19	\$6.84
½" Shoulder Bolt	McMaster Carr	90298A716	90298A716	By Sponsor	1/22/19	1/30/19	\$7.55
Force Gauge	Amazon	NK-200	N/A	By Sponsor	1/22/19	1/31/19	\$62.00
Wire Rope End Fittings	McMaster Carr	3869T62	N/A	By Sponsor	4/4/19	4/9/19	\$29.12
18-8 Stainless Steel Shoulder Screws	McMaster Carr	90298A548	N/A	By Sponsor	4/4/19	4/9/19	\$19.38
18-8 Stainless Steel Button Head Hex Drive Screws	McMaster Carr	97763A143	N/A	By Sponsor	4/4/19	4/9/19	\$3.31
Hitch Pin	McMaster Carr	Haul Master 65432	N/A	By Sponsor	12/13/18	1/22/19	\$7.98
Receiver Tube	McMaster Carr	2507T63	N/A	By Sponsor	12/13/18	1/22/19	\$19.99
0.188" Wall Thickness, 2" x 2" Outside Size 3ft long	McMaster Carr	6527K514	TH3001	By Sponsor	12/13/18	1/22/19	\$35.78
0.120" Wall Thickness, "1-1/2" x 1-1/2" Outside Size, 6ft Long	McMaster Carr	6527K374	N/A	By Sponsor	12/13/18	1/22/19	\$70.72
Trailer Coupler	McMaster Carr	2743T5	N/A	By Sponsor	12/13/18	1/22/19	\$14.47
Multipurpose 6061 Aluminum Rectangular	McMaster Carr	6546K6	N/A	By Sponsor	5/13/19	5/15/19	\$26.82

Tubes 1.5"							
Multipurpose 6061 Aluminum Sheets and Bars with Certification 2"X24", 1/8" thick	McMaster Carr	9015T271	N/A	By Sponsor	5/13/19	5/15/19	\$21.08
Super-Cushioning Abrasion-Resistant Polyurethane Rubber Sheets and Strips	McMaster Carr	8514K54	TH3045	By Sponsor	5/13/19	5/15/19	\$10.32
Extension Springs with Loop Ends	McMaster Carr	9654K317	N/A	By Sponsor	5/13/19	5/15/19	\$9.86
Corrosion-Resistant Extension Springs with Loop Ends	McMaster Carr	9065K365	N/A	By Sponsor	5/13/19	5/15/19	\$10.16
Total Cost							\$1014.50

15 APPENDIX E: DECISION MATRIX/PUGH MATRICES

		Idea #1	Idea #2	Idea #3	Idea #4	Datum
Characteristics	Weights	Idea A				Current process
Ease of use	5	-1	1	-1	1	-1
Speed	2	0	1	0	1	-1
Safety	4	0	0	0	0	1
weatherproof	3	0	0	0	0	0
Cost	2	-1	-1	-1	1	1
Ease of manufacturing	3	-1	0	-1	1	0
Weighted sum of the +1		0	7	0	9	6
Weighted sum of the -1		-10	-2	-10	0	-7
Weighted total		-10	5	-10	9	-1

	Idea A	Idea B	Idea C	Idea D
Coupling	Black box	improved lever	Black Box	Modified Coupler
Rotating	track rotator	Telescoping rotator	Telescoping Rotator	telescoping
Pins	torsion pin	Compression spring pin	Torsion shear Pin	torsion shear pin
Hooks	hook with handle	Modified safety chains	Hook with handle	hook with handle
Electrical	Magnetic weather cover	friction washer	Magnetic weather cover	Magnetic weather cover

FUNCTION: ATTACH SAFETY CHAINS

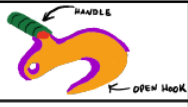

CONCEPTS CRITERION	DATUM (CARIBINERS)		
LITTLE DEXTERITY REQ'D	S	+	+
FLEXIBLE FOR USE w/ DIFF. TRAILERS	S	S	+
MECHANICAL SOUND	S	S	-
*PLUG AND PLAY w/ VEHICLE	S	S	-
ACCESSIBLE	S	S	+
EASY TO MFG.	S	S	-
TOTAL	- -	+1	0

Figure 63: Pugh matrix for safety chains

	Datum	large lever	Block box	auto lock	Motion?
Speed	S	+	-	+	+
ease	S	+	+	+	+
leverage	S	+	-	-	-
Space	S	-	-	-	-
Cost	S	-	-	-	-
Stowing	S	-	-	-	-
pmch points	S	-	+	+	-
flexibility	S	+	-	-	-
manufacturability	S	-	-	-	-

Figure 64: Pugh Matrix for Coupler Lever

FUNCTION: INSTALL HITCH PIN

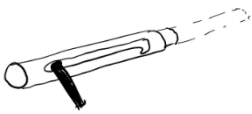
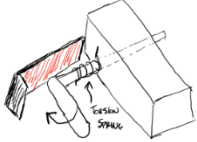
CONCEPTS CRITERION	DATUM LYNCH & COTTER PIN		
LITTLE DEXTERITY REQ'D	S	+	+
NO LOOSE PARTS	S	+	+
	S		
	S		
	S		
EASY TO MFG.	S	-	+
TOTAL	--	+1	0

Figure 65: Pugh Matrix for Installing Hitch Pin

16 APPENDIX F: ANALYSES

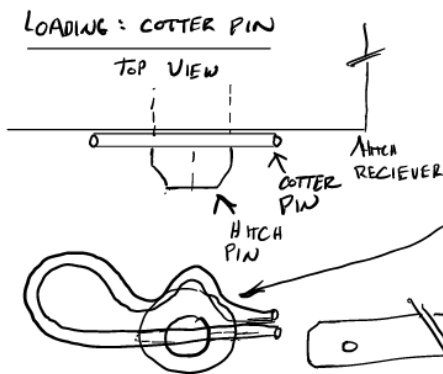
ANALYSIS: CAPTIVE PIN "PIN RETAINER"

1/12/18 28

This analysis is performed with the goal to verify the reliability of a new hitch pin retainer for a trailer hitch. To begin, I will estimate the breaking strength of the current cotter pin used widely across trailer hitches.

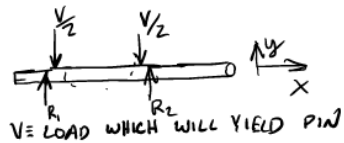


FIGURE 1: COTTER PIN (LEGACY)



FBD → COTTER PIN

SINCE THE TOP SECTION OF THE COTTER PIN IS FREE TO SLIDE, ASSUME IT CARRIES NO SHEAR.



$$R_1 = R_2 = \frac{V}{2}$$

$$\tau_{max} = \frac{4(\frac{V}{2})}{A_{cs}} = \tau_{YIELD}$$

$$V = \frac{3}{2} A_{cs} \tau_y$$

ASSUME PIN IS HIGH STRENGTH ALLOY STEEL → GIVES A HIGH ESTIMATE OF STRENGTH TO DUPLICATE.

4140 STEEL, NORMALIZED

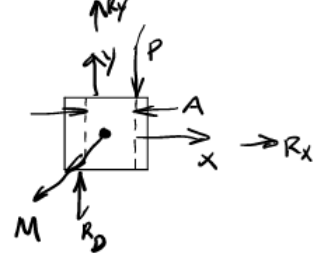
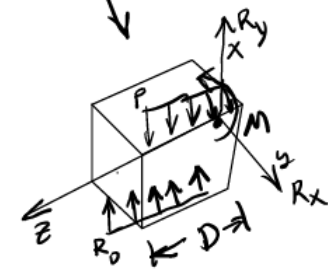
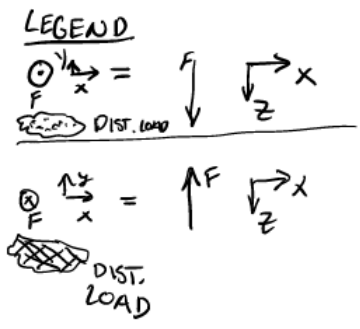
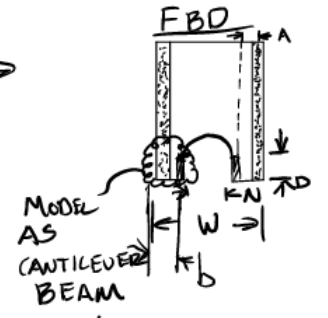
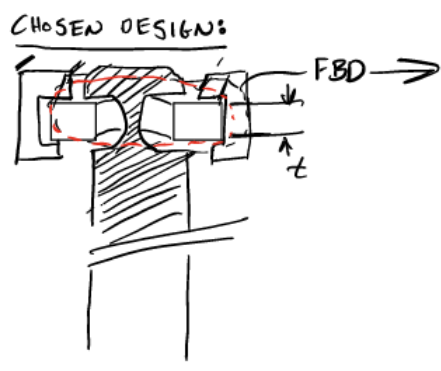
$$S_y = 95 \text{ KSI} \Rightarrow \tau_y = 55 \text{ KSI}$$

$$V = \frac{3\pi}{2} d^2 (55 \text{ KSI}) =$$

$$V = \frac{3\pi}{8} (.156 \text{ in})^2 (55 \text{ KSI})$$

$$V = 1577 \text{ LB}$$

This analysis is being performed to develop a baseline from which to design a pin retainer. It is not meant to establish a factor of safety.

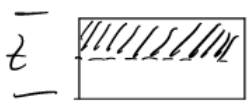


$R_x = R_y = 0$

$R_0 = P$

$M = PA$

$A = .086 \text{ in}$



$I = \frac{1}{12} D t^3$

$Q = \frac{t}{4} \left(\frac{D t}{2} \right) = \frac{D t^2}{8}$

$\tau_{max, cs} = \frac{P Q}{I D}$

$P = \frac{V}{2}$ FROM PREV. PAGE

$\tau_{max, cs} = \frac{3P}{2 D t}$

$D = .15 \text{ in}$

$t = .156 \text{ in}$

$\tau_{max, cs} = \frac{3(788 \text{ lb})}{2(.15 \text{ in})(.156 \text{ in})} = 59,513 \text{ PSI}$

$\tau_{max, TORSION}$

$M = (788 \text{ lb})(.086 \text{ in})$

$M = 67.7 \text{ lbf-in}$

FOR NONCIRCULAR SECTION,

$\tau_{max} = \frac{M}{\alpha b c^2}$

$b = .21$

$c = .156$

$\alpha = .22$

$\tau_{max} = \frac{67.7 \text{ lbf-in}}{(.22)(.21)(.156 \text{ in})^2} = 60,214 \text{ PSI}$

$\sigma_{vm} = \sqrt{3} \tau_{max} = 104.3 \text{ KSI}$

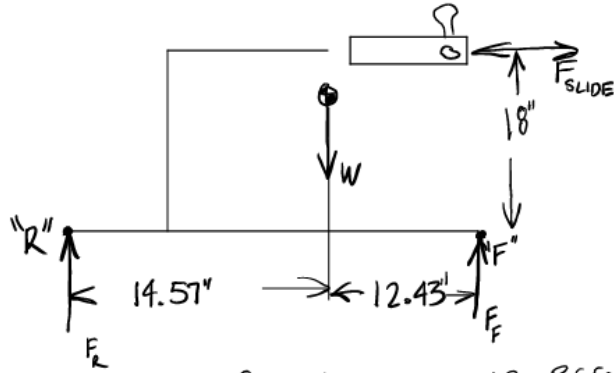
303 STAINLESS:

$S_y = 60,200 \text{ PSI}$

$V_{max} = \frac{S_y}{\sigma_{vm} F_{s,y}} V = 1577 \left(\frac{60,200}{104,300} \right) = 910 \text{ lbf}$

STATIC ANALYSIS: TEST FRAME

33



FINDING MAX LOAD BEFORE TIPPING

$$\sum M = 0$$

$$F_R = 0$$

$$W(12.43") - F_{SLIDE}(18") = 0$$

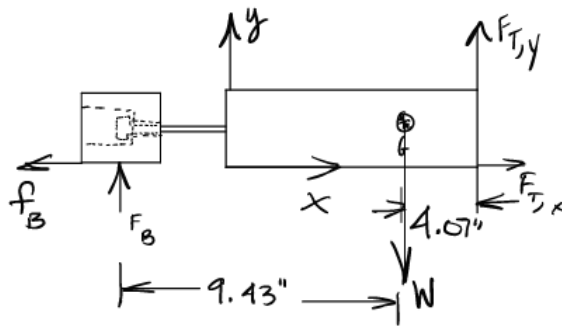
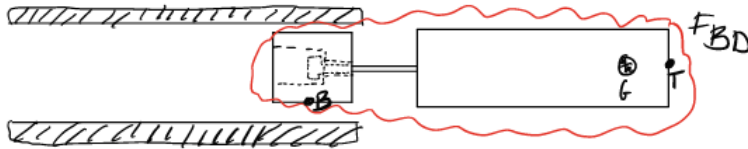
$$W = 61.65 \text{ lb}$$

$$F_{SLIDE} = W \left(\frac{12.43"}{18"} \right)$$

$$F_{SLIDE \text{ MAX}} = \left(\frac{12.43}{18} \right) 61.65 \text{ lb}$$

$$F_{SLIDE \text{ MAX}} = \underline{42.5 \text{ lb}}$$

$F_{SLIDE} \ll 42 \text{ lb} \Rightarrow$ THIS DESIGN WILL
 BE SUITABLE FOR TESTING,
 SEE SUBSEQUENT PAGES 34-35
 FOR ESTIMATES OF ACTUAL
 F_{SLIDE} VALUES IN VARIOUS TESTS



STEEL ON STEEL:

$$\mu_s = 0.7$$

$$f_B = \mu_s F_B$$

$$W = 11.14 \text{ lbf}$$

$$\sum M_B = 0$$

$$F_{T,y} (13.5") - W (9.43") = 0$$

$$F_{T,y} = W \left(\frac{9.43}{13.5} \right)$$

$$F_{T,y} = .699W \quad \text{Y-COMPONENT OF USER-APPLIED FORCE}$$

$$F_B = .301W$$

$$f_B = 0.7(.301)W$$

$$f_B = .211W$$

$$\sum F_x = 0$$

$$F_{T,x} = f_B$$

$$F_{T,x} = .211W$$

$$|F_T| = W \sqrt{(.211)^2 + (.699)^2}$$

$$|F_T| = .73W$$

$$|F_T| = 8.13 \text{ lbf}$$

PREDICTED APPLIED FORCE BY USER AT LONGEST EXTENSION

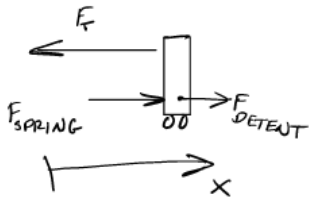
ASIDE: F_{DETENT}

REPRESENTATIVE BALL DETENT CLIMBING A RAMP TO ITS NOTCH

- ① $F_N = \frac{F_{DETENT,S}}{\cos \theta}$
- ② $F_{DETENT} = F_N \sin \theta$
- ③ $F_{DETENT} = F_{DETENT,S} (\tan \theta)$
- $F_{DETENT,S} = 2(5lb)$ ← 2 DETENTS USED IN ANTI-OPPOSED CONFIG...
- ④ $F_{DETENT,S} = 10lb$
- ⑤ $\theta = 26.65^\circ$ (FROM CAD)
SUPPLY ④ & ⑤ INTO ③
- $F_{DETENT} = 10lb (\tan(26.65^\circ))$

$F_{DETENT} = 5.02 lb$

CONTINUE TO FIND F_T : FORCE TRANSMITTED BY USER



$F_{SPRING} = 5.5lb$ (MAXIMUM)
 $F_{DETENT,S} = 5 lb$ (MAX.) EACH (2x)

$$F_T = F_{SPRING} + F_{DETENT}$$

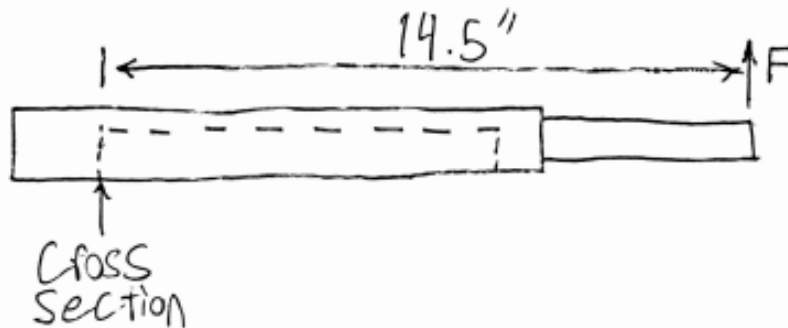
$$F_T = 5.5lb + 5.02lb$$

$F_T = 10.52lb$

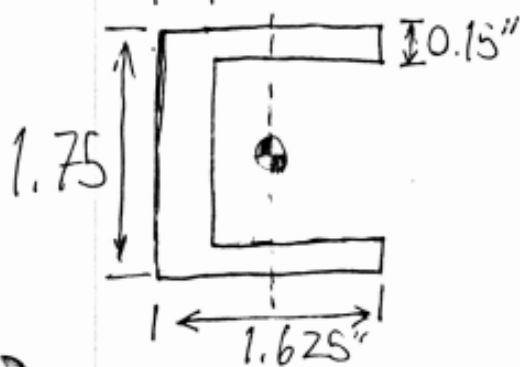
← MAXIMUM APPLIED FORCE TO RELEASE MECHANISM

Bending Stress in the Coupler Level

- The Design Criteria is 25lb of actuating Force.
- The smallest crosssection is in the Pocket, so the maximum bending stress will be at the point in the pocket farthest from the applied force.



$$M = (14.5 \text{ inches})(25 \text{ lb}) = 362.5 \text{ in-lb}$$



$$\sigma_{\text{bend, max}} = \frac{M c}{I}$$

$c \equiv \perp$ distance to neutral axis
 $I \equiv$ Moment of inertia of cross-section about the neutral axis

www.amesweb.info

$$I = 0.205 \text{ in}^4$$

$$c = 0.525 \text{ in}$$

$$\sigma_{\text{bend}} = \frac{(362.5 \text{ in-lb})(0.525 \text{ in})}{(0.205 \text{ in}^4)} = 928.35 \text{ Psi}$$

17 APPENDIX G: DESIGN VERIFICATION PLAN

Date: 05/28/2019										Team: 64: Trailer Hitch										Sponsor: CL+										Senior Project DVP&R										DVP&R Engineer: Max Selva									
Description of System: Adapted Trailer Hitch for improved usability with a single prosthetic arm																																																	
TEST PLAN																				TEST REPORT																													
Item No.	Specification #	Test Description	Acceptance Criteria	Test Responsibility	Test Stage	SAMPLES	TIMING	TEST RESULT	TEST RESULTS	NOTES																																							
1	1	Force Test	25lbf max	All	FP	4 Sub	4/2/2019	5/10/2019	Pass	12	1	Redundant Test failed, Plan B Passed									"QTY" is total number of trials																												
2	4.2	Oven Mitt Test/Timed Test	Usable	All	FP	3 Sub	4/2/2019	5/10/2019	Pass	12	0																																						
3	3	Corrosion Resistance	Later Functionality	All	FP	1 Sub	4/2/2019	5/10/2019	Pass	1	0																																						

18 APPENDIX H: FMEA

Team	System / Function	Potential Failure Mode	Potential Effects of the Failure Mode	Severity	Potential Causes of the Failure Mode	Current Preventative Activities	Occurrence	Current Detection Activities	Detection	RPN	Recommended Action(s)	Responsibility & Target Completion Date	Actions Taken	Detection Results		
														Severity	Occurrence	Criticality
	Tri Ball/Rotate Tri-Ball	Misalignment/Binding in support tube	Shoulder Bolt Deflection/Yield	5	Shoulder Bolt too small/ too long	1) Design for stiffness and strength	3	User report of operator smoothness	1	15	Account for adverse loading during carrier/wed layout	1/15/19	Large factor of safety against shoulder bolt yield was achieved by opting for a large bolt.			
		Retention Cable Malfunction	Cable tangle	4	Slack cable gets trapped between receiver and hitch tube	1) Use a cable larger than gap between tubes 2) free space behind receiver is used as a place for cable to loop	5	Customer feedback	2	40	1) Spring, Tension the cable to eliminate slack 2) Use a rigid retainer	1/15/19	Large open space behind receiver allows for cable looping			
	Wiring harness	Difficult to open	time and hassle	3	Current mechanism magnets	magnet selection and testing	2	Response from user	1	6	Test magnet pull strength and pull strength of Taylor	1/15/19	Retaining magnets have been selected to reflect the force exerted by the original torsion spring			
		Is not weatherproof	short term life/ electrical failure	5	not a good enough seal/ not enough force		3	Response from user: electrical failure water found inside of door	8.0	120	try water testing to make sure seal is still intact with magnets instead/ torsion spring and check for different possible seals	1/15/19	Magnets have been selected to create the same damping force on the seal as the torsion spring			
	Safety Chains/ Retain Trailer	Hooks detach from receiver	chains drag on ground	2		1) Proper hook design 2) Proper hooking procedure	2	inspector user response	6	24	Through testing find hooks that don't come out easy	1/25/19				
			trailer disconnects from car	10	1) Rough road 2) Inappropriate hooks	1	20	extensive testing of hooks driving over different surfaces	1/25/19							
		chain snaps	trailer fully disconnects from car	10	Failure of hitching system followed by: 1) corroded chains 2) worn down chains 3) improper hook-up	Proper hook-up and maintenance	1	Repeated load/ fatigue testing	2	20	use well maintained chain with high factor of safety	1/25/19	The safety chains are selected for the max gross trailer weight so that one (1) is sufficient in restraining the trailer should the coupler disengage.			
		Bend or break	Limited utility and function	7	excess force- Poor design or material.	high factor of safety	4	testing and examination of part	4	112	robust design and thorough testing	1/25/19	The safety Chain hooks are designed to support more than the load of the trailer after a 5:1 safety factor.			
	Chester Bar	Incorrectly sized	Chester bar fails to perform its intended purpose.	6	bad design. Variation in coupler latches	detailed design analysis	4	testing on a variety of couplers	4	96	mechanism path analysis	1/25/20				

Action Results																
System / Function	Potential Failure Mode	Potential Effects of the Failure Mode	Severity	Potential Causes of the Failure Mode	Current Preventative Activities	Occurrence	Current Detection Activities	Detection	RPN	Recommended Action(s)	Responsibility & Target Completion Date	Actions Taken	Severity	Occurrence	Criticality	RPN
	Incorrectly sized	cheater bar fails to perform its intended purpose.	6	bad design. Variation in coupler latches	detailed design analysis	4	testing on a variety of couplers	4	96	mechanism path analysis	1/25/20					
	Mallet surface isn't secured correctly.	mallet surface bend or flaps off, limiting utility.	4	bad construction. Poor choice of materials.	research and testing	6	testing and examination of part	3	72	robust design and thorough testing	1/25/21					
Cheater Bar	release latch tab isn't supported correctly	tab bends and no longer serves its intended purpose.	5	bad design. External damage.	informed choice of production method. High factor of safety.	4	testing and examination of part	3	60	robust design and thorough testing	1/25/22					
									0							
	Inconvenient/ hard to use	frustration by user / help required	5	motion of pin/ locking mechanism	simple motions and procedure	4	customer response	1	20	test with limited mobility to simulate bayors motions	1/15/19					
	comes loose in transit	potential catastrophic failure	10	locking mechanism insufficient	testing of locking mechanism and designing for loads	2	testing and designing	4	80	make this specific process with a high safety factor	1/15/19	A locking mechanism has been designed to withstand vibration and heavy				
Pinning system	does not hold load	potential catastrophic failure	10	pin failure because of loading	make sure pin is up to sae standards and nothing is done to compromise those standards	1	testing and meeting standards	7	70	do not compromise pin	1/15/19	A standard hitch pin has been selected and our design requires no modifications				

19 APPENDIX I: RISK ASSESSMENT

Trailer Hitch

2/12/2019

designsafe Report

Application: Trailer Hitch

Analyst Name(s):

Description: 5-operation adapted trailer hitch system for quadruple amputee.

Company:

Product Identifier:

Facility Location:

Assessment Type: Detailed

Limits:

Sources:

Risk Scoring System: ANSI B11.0 (TR3) Two Factor

Guide sentence: When doing [task], the [user] could be injured by the [hazard] due to the [failure mode].

Item Id	User / Task	Hazard / Failure Mode	Initial Assessment		Risk Reduction Methods /Control System	Final Assessment		Status / Responsible /Comments /Reference
			Severity /Probability	Risk Level		Severity /Probability	Risk Level	
1-1-1	All Users Common Tasks	mechanical : pinch point spring loaded slider, trnball rotating mechanism	Minor Remote	Negligible	Safety labels	Minor		
1-1-2	All Users Common Tasks	electrical / electronic : water / Minor wet locations Short due to wet electrical terminals	Remote	Negligible	Electrical receptacle is sealed with a gasket which is compressed with a magnetic lock.	Minor		
1-1-3	All Users Common Tasks	ergonomics / human factors : Minor posture Some functions require operator to lean over	Likely	Low	Amend handle design for reduced chronic fatigue	Minor		
1-1-4	All Users Common Tasks	ergonomics / human factors : Minor lifting / bending / twisting Some functions require operator to apply force away from their body	Likely	Low	Amend handle design	Minor		

20 APPENDIX J: OPERATOR'S MANUAL

This user manual contains instructions and guidelines to promote safe operation of the adapted trailer hitching system. **Read this manual carefully before use to avoid personnel injury and/or damage to the product.**

20.1 TOWING CAPACITY

The basis for the adapted trailer hitching system is an OEM receiver frame intended for use on 2014 Jeep Grand Cherokee. **Refer to the operator's manual for the receiver and the vehicle owner's manual for specific information pertaining to the towing capacity of the receiver/vehicle combination and for installation instructions.**

20.2 OPERATION OF ADAPTED HITCH RECEIVER

20.2.1 Using the custom hitch pin retaining system to remove and install the hitch pin

The hitch pin retaining system has been custom designed for use with a 5/8" diameter groove style hitch pin as shown in Figure 66. The system eliminates the need for a cotter pin and instead uses a retaining plate that interlocks with the notched pin.

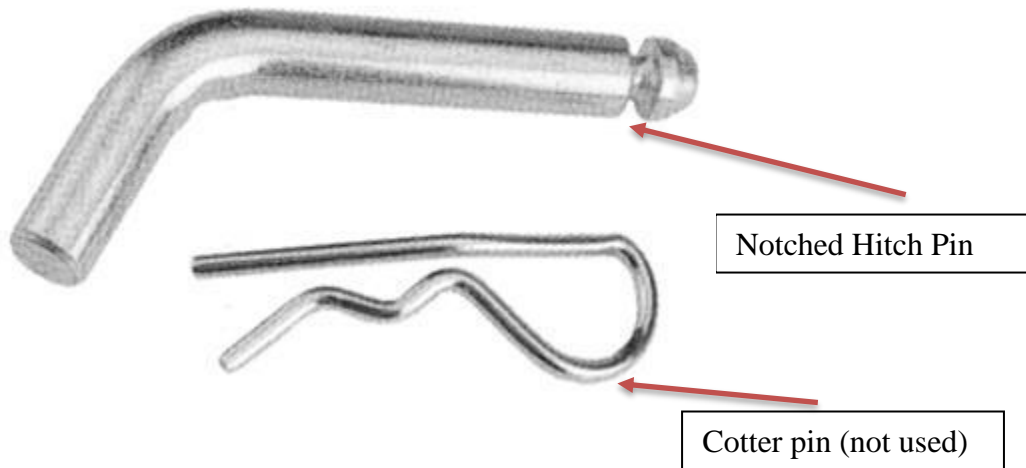


Figure 66: Notched hitch pin. Tow Ready #63240

Operation Sequence:

1. Releasing the pin
 - a. Use the pull handle to unlock the retaining plate from the groove in the hitch pin. The plate will click into its open position as in Figure 67.

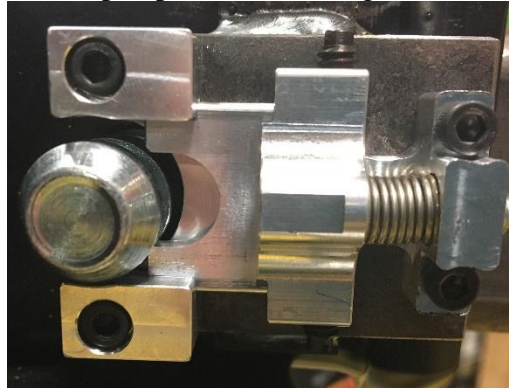


Figure 67

- b. Remove the hitch pin and allow it to hang from its retaining cable.
2. Re-Installing the pin
 - a. Line up the pin holes in the hitch receiver with those in the hitch.
 - b. Slide the pin in so that the retaining plate is lined up with the notch on the pin.
 - c. Press the pull handle in, ensuring the retaining plate fully seats in the closed position. See Figure 68.



Figure 68

3. Maintenance

The moving components of this system are machined from stainless steel and are resistant to corrosion. Dirt and grime will accumulate in the sliding interface over time and may cause it to bind or hang up. The mechanism can be disassembled and cleaned using rubbing alcohol if necessary. Use a rust inhibitor during re assembly; the ball detents are made of steel and can rust. Rust buildup will make the mechanism difficult to open and close.
4. Safety
 - a. Keep Fingers clear of the sliding components.
 - b. Failure to properly secure the hitch pin (as shown in Figure 68) can result in the trailer becoming detached from the vehicle.

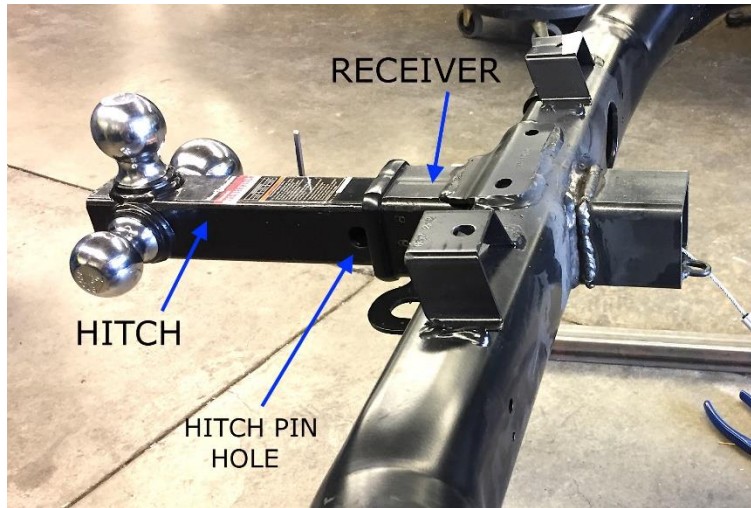
20.2.2 Using the modified electrical receptacle

1. Opening and closing the doors
 - a. The operation of the doors has not changed, they still swing open on their hinges.
2. Things to note.
 - a. The doors will now be completely open, or completely closed.
 - b. Make sure that the doors are closed when the receptacle is not in use in order to maintain weatherproof seal.
 - c. Make sure that all magnets are present when you are attaching brake lights.
 - d. Do not slam the doors.



3. Maintenance
 - a. Replacing the magnets should they fall out or get lost
 - i. Clear any debris from slot where magnet resides
 - ii. Use epoxy to reattach magnet
 - iii. If new magnet is necessary, ordering information is below.
 - b. Magnet part number: 7048T240
 - c. Link: <https://www.mcmaster.com/catalog/125/3606>
4. Safety
 - a. Failure to completely close the electrical receptacle doors may cause corrosion that will damage the contacts. Damaged contacts may cause loss of brake light functionality and unsafe towing conditions.

20.2.3 Using the hitch rotation mechanism



1. Remove hitch pin by following the procedure for the pin retaining system.
2. Pull out the hitch until it is completely suspended outside the hitch receiver.



3. Rotate the hitch until the desired ball size is oriented upward as shown in Figure 69.



Figure 69

4. Slide the hitch back into the receiver until the holes for the hitch pin on the hitch and the receiver are lined up as shown in Figure 70.

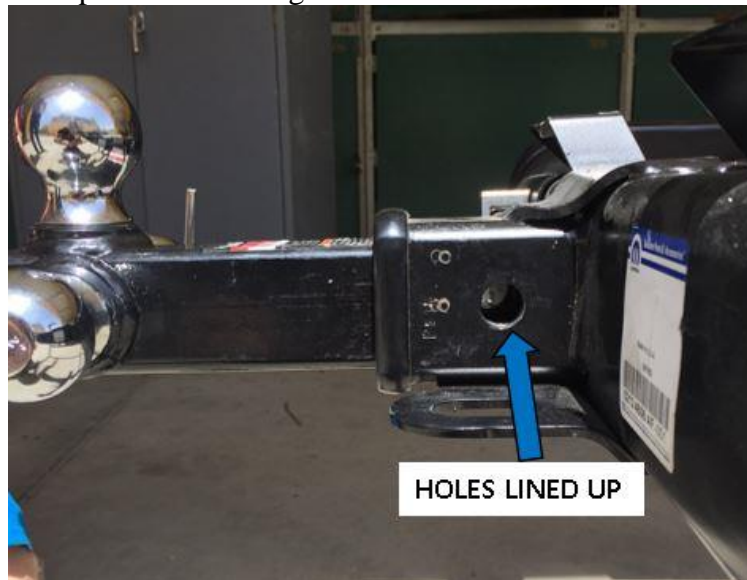


Figure 70

5. To re-insert the hitch pin, follow the procedure above for operating the pin retaining system.

Maintenance:

If the motions are difficult, apply grease to the square shaft of the hitch and the round shoulder of the bolt supporting the hitch.

Safety:

1. Periodically inspect the retaining cable for corrosion and fraying, and replace if necessary.
2. Watch out for pinch points between the trailer hitch and receiver.

20.2.4 Using the trailer coupler actuation lever

The coupler actuation lever is a device that should be stored within the vehicle or kept in proximity with the trailer for easy use.

1. Unlocking the coupler
 - a. Attach actuation lever to trailer coupler by positioning it above the release and pushing down.

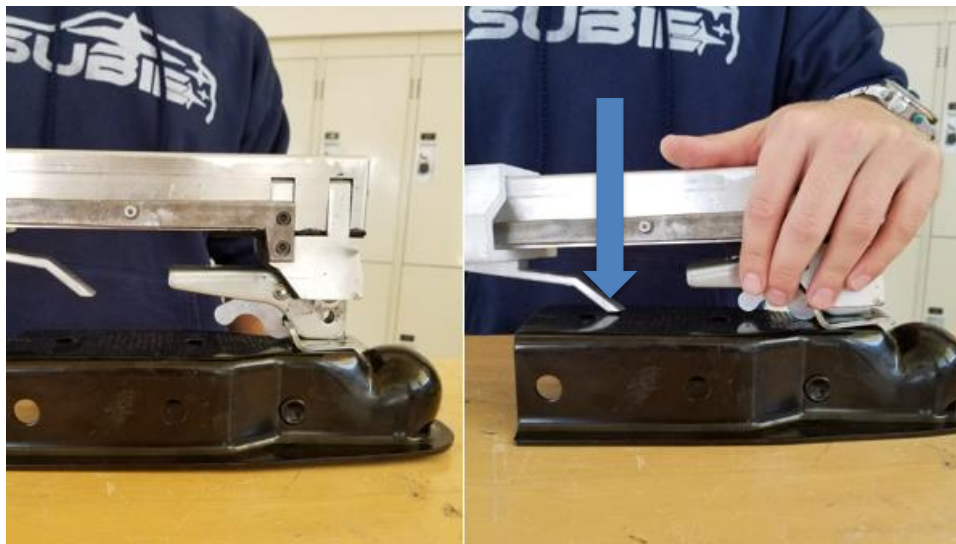


Figure 71

- b. Move the slider toward the coupler to lock in the grips

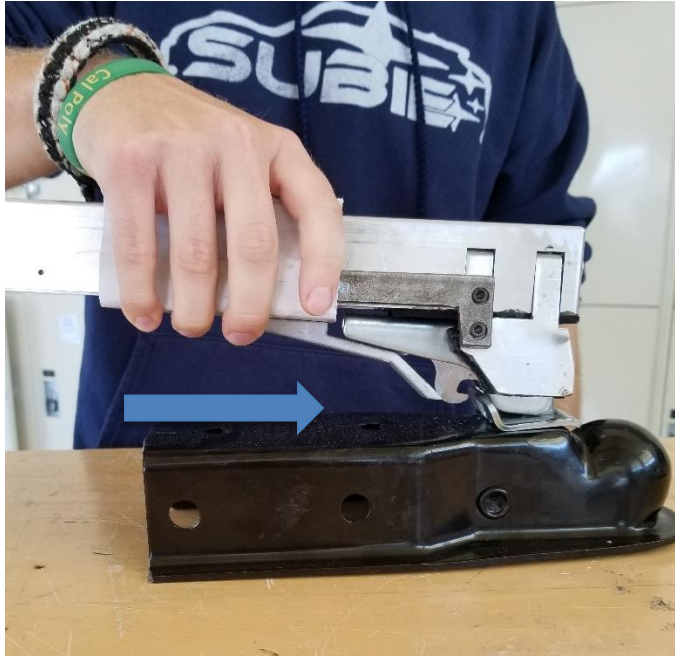


Figure 72

- c. Lift the handle to actuate the coupler



Figure 73

- d. Move slider away from coupler
- e. Remove actuation lever
2. Locking the coupler
 - a. Attach actuation lever to trailer coupler

- i. May need to apply pressure to ensure grip
- b. Move the slider toward the coupler to lock in the grips
- c. Push the handle down toward the trailer to actuate coupler
- d. Move slider away from coupler
- e. Remove actuation lever
Push the

20.2.5 Proper safety chain attachment

1. Attach the safety chains to the trailer.
2. Attach the safety chains to the eyelets on your vehicle.
 - a. Make sure that you cross the chains under the tongue of the trailer
3. Make sure that the hooks are secured in the eyelets as shown in Figure 74.



Figure 74

21 APPENDIX K: DRAWING PACKAGE

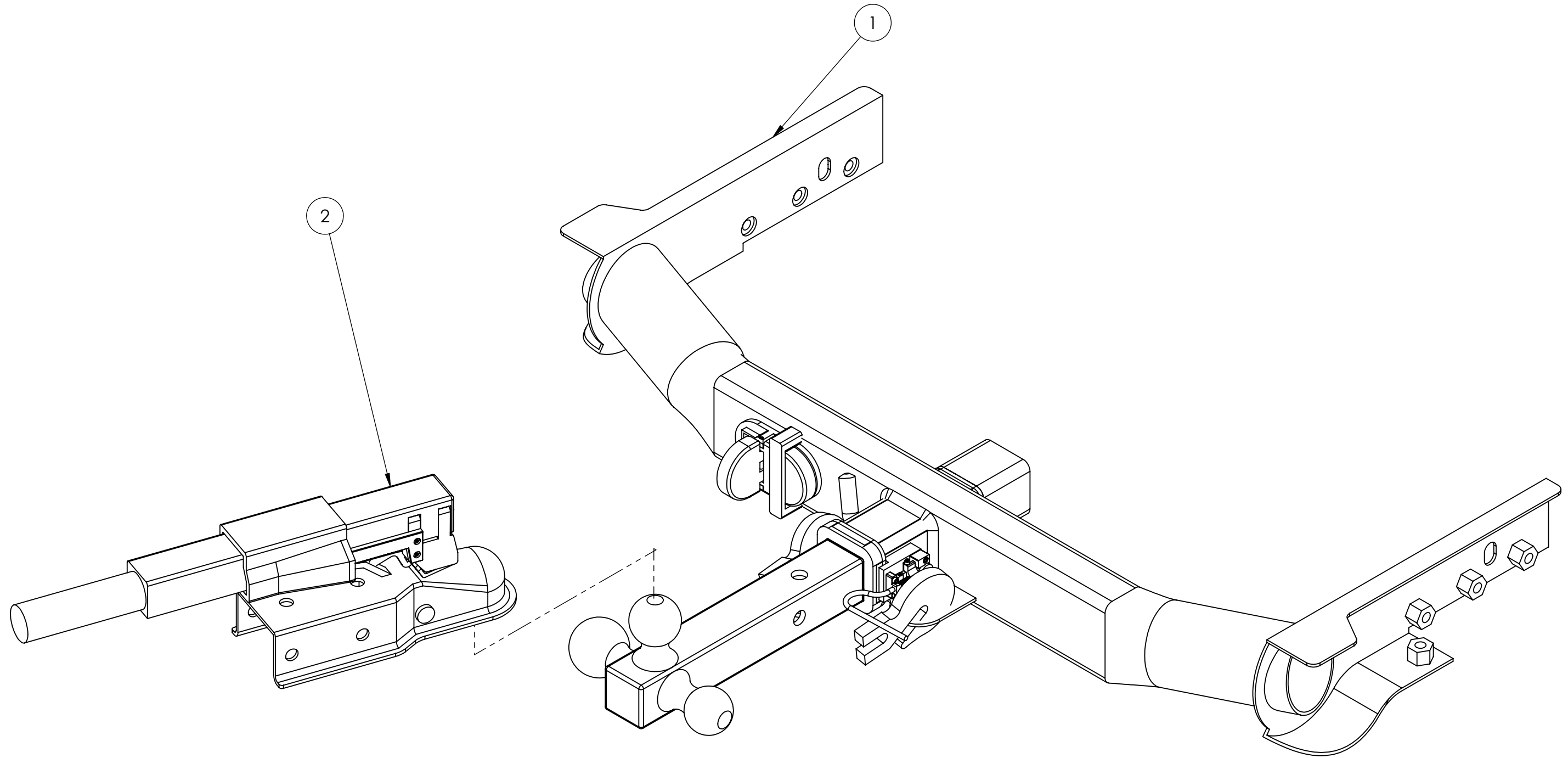
The next 27 pages contain the drawing package for this project.

Adapted Trailer Hitch Assembly BOM

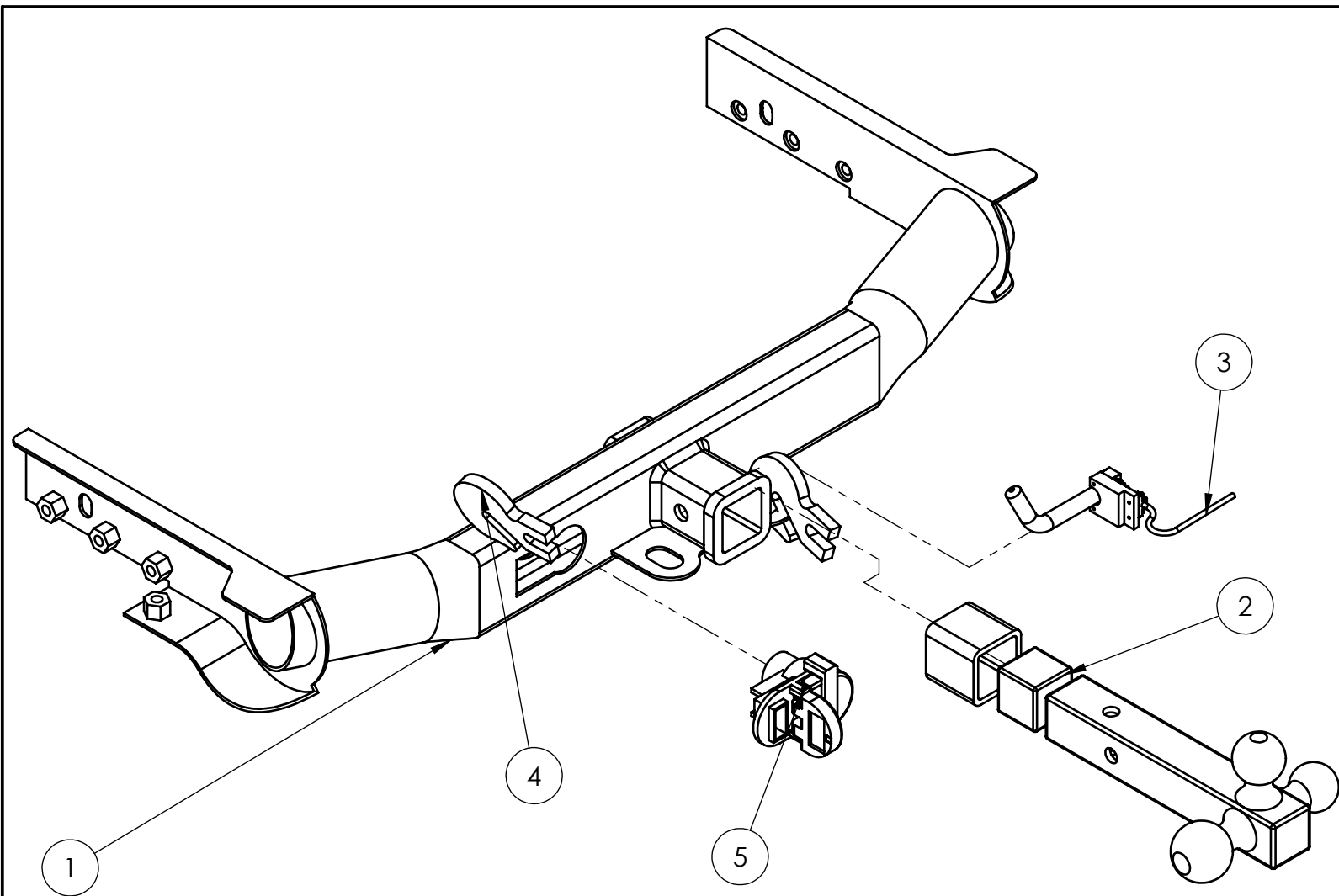
Assy Level	Part Number	Description				Material	Vendor	Qty	Cost	Total Cost
		Lvl 0	Lvl 1	Lvl 2	Lvl 3					
0	TH0	Complete Trailer Hitch Assembly								
1	TH1000		Receiver with Accessories							
2	Mopar 82212180AC			Standard Jeep Hitch Receiver		Steel	Mopar.com	1	\$262.00	\$262.00
2	TH2000			Tri-Ball Rotator				1		\$0.00
3	Haul Master 61914				Tri-Ball Hitch	Steel	Harbor Freight	1	\$33.99	\$33.99
3	McMaster 90298A716				Shoulder Bolt, 1/2" Sh.x 1 1/2" long, 3/8"-16 Threads	SST 18-8	McMaster Carr	1	\$7.55	\$7.55
3	TH3001				Sliding Block, 2"x2"x2"	Mild Steel	----	1		\$0.00
3	TH3002				Reciever Extension w/ cable loop	Mild Steel	----	1		
3	TH3003				Limiting Cable	Steel	McMaster Carr	1		\$0.00
3	TH3004				Cable Clamp with thimble	Steel	McMaster Carr	2		\$0.00
2	TH2010			Pin Retainer System				1		\$0.00
3	Tow Ready 63240				5/8" Hitch Pin w/ groove	Steel	Amazon	1	\$8.95	\$8.95
3	TH3011				Notch Plate	SST 303	-----	1		\$0.00
3	TH3012				Notch Plate Carrier	SST 303	-----	1		\$0.00
3	TH3013				Notch Plate Carrier base Plate	Mild Steel	-----	1		
3	McMaster 9435K61				Compression Spring	SST 302	McMaster Carr	1	\$1.37	\$1.37
3	McMaster 3408A521				Ball Detent	Steel	McMaster Carr	2	\$4.62	\$9.24
3	TH3014				Pull Handle	SST 303	-----	1	\$0.00	\$0.00
3	McMaster 92196A148				6-32 SHCS 1/2" Length	SST 18-8	McMaster Carr	4	\$0.05	\$0.20
2	McMaster 92196A953				6-32 SHCS 3/32" Length	SST 18-8	Mcmaster Carr	1	\$2.68	\$2.68
3	TH2020		Modified Electrical Receptacle							
3	56055632AC-M			Mopar Trailer Hitch Electrical Receptacle		Plastic	Mopar.com	1	\$49.99	\$49.99
3	TH3021			Receptacle Cage Assembly						
	Mcmaster 7048T24				Lock Magnet	Neodymium	McMaster Carr	4	\$3.87	\$15.48
	TH3022				Cage	6061-T6 Aluminum		2		
1	TH3021					Mild Steel	-----	2		\$0.00
2	Temco TH0047			Grab Hook		High Strength Steel	Amazon	6	\$10.09	\$60.54
1	TH1010		Tongue Lever							\$0.00
2	TH2030			Coupler Lever Handle		Mild Steel	-----			\$0.00
3	TH3031				Handle Main Body			1		
3	TH3032				Shoulder Bolt	Stainless Steel	McMaster Carr	2	\$3.23	\$6.46
2					Spring					
3	TH2040			Flange		Mild Steel	-----			\$0.00
3	TH3041				Left Flange Body	6061-T6 Aluminum	----	1		
3	TH3042				Left Wing	Mild Steel	----	1		
3	TH3043				Right Flange Body	6061-T6 Aluminum	----	1		
3	TH3044				Right Wing	Mild Steel	----	1		
2	TH3045				Pad	Rubber	----	2		
3	TH2050			Collar						
3	TH3051				Collar Body	PLA	----	1		
	TH3052				Incline	6061-T6 Aluminum	----	1		
	TH1020		Tongue Lever (B)							
	TH2060			Main Body (B)		6061-T6 Aluminum	----	1		
	TH2061			Incline (B)		6061-T6 Aluminum	----	2		

TOTAL \$458.45

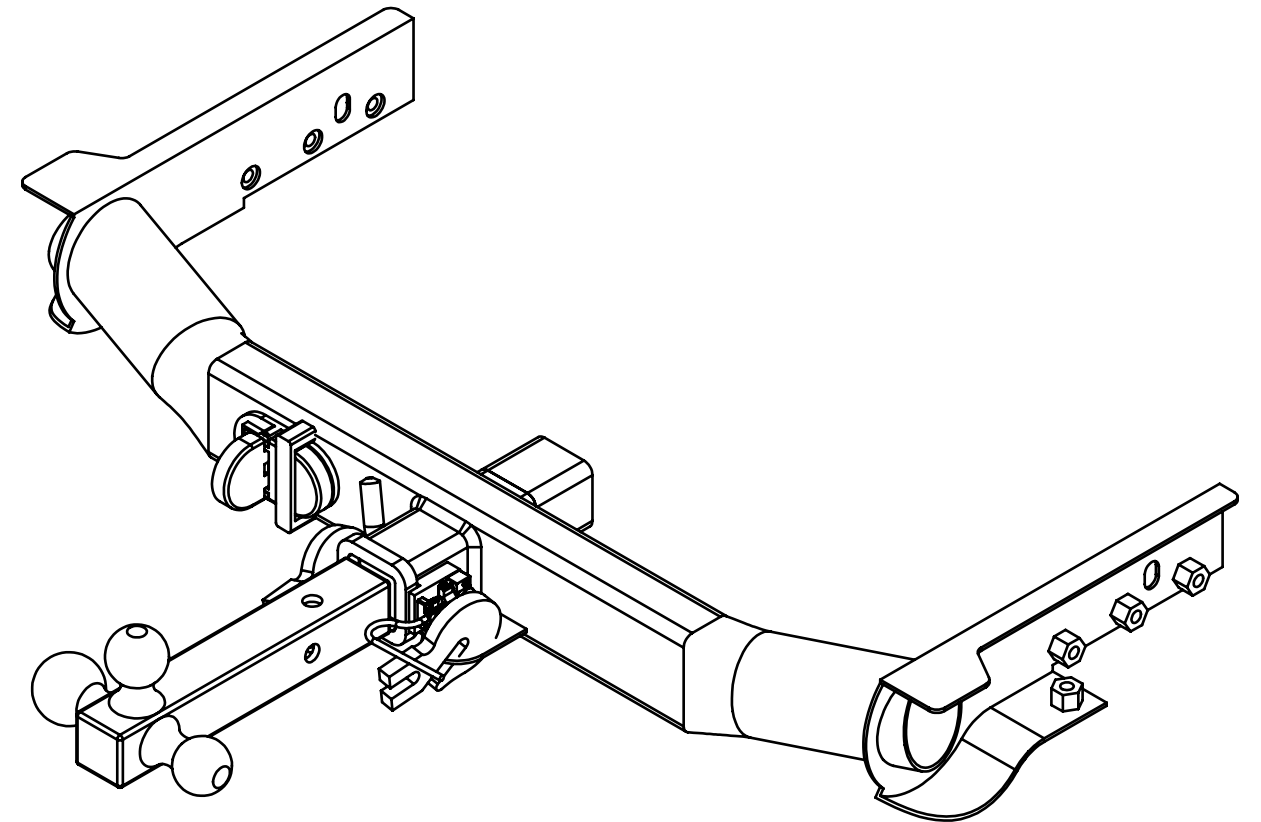
ITEM NO.	PART NUMBER	DESCRIPTION	QTY.
1	TH1000	RECEIVER WITH ACCESSORIES	1
2	TH1010	TONGUE LEVER	1



Cal Poly Mechanical Engineering ME 429 - WTR 2019	Lab Section: 06	MATL: VARIOUS	Title: COMPLETE TRAILER HITCH ASM	Drwn. By: M. SELNA (64 HITCH)
	Dwg. #: TH0	TOP LEVEL	Date:02/07/2019	Scale: 1=4 Chkd. By: ERIC RINGSRUD



ITEM NO.	PART NUMBER	DESCRIPTION	QTY.
1	MOPAR 82212180AC	STANDARD JEEP HITCH RECEIVER	1
2	TH2000	TRI-BALL ROTATOR	1
3	TH2010	PIN RETAINER SYSTEM	1
4	TEMCO TH0047	GRAB HOOK	2
5	TH 2020	MODIFIED ELECTRICAL RECEPTACLE	1



Cal Poly Mechanical Engineering
ME 429 - WTR 2019

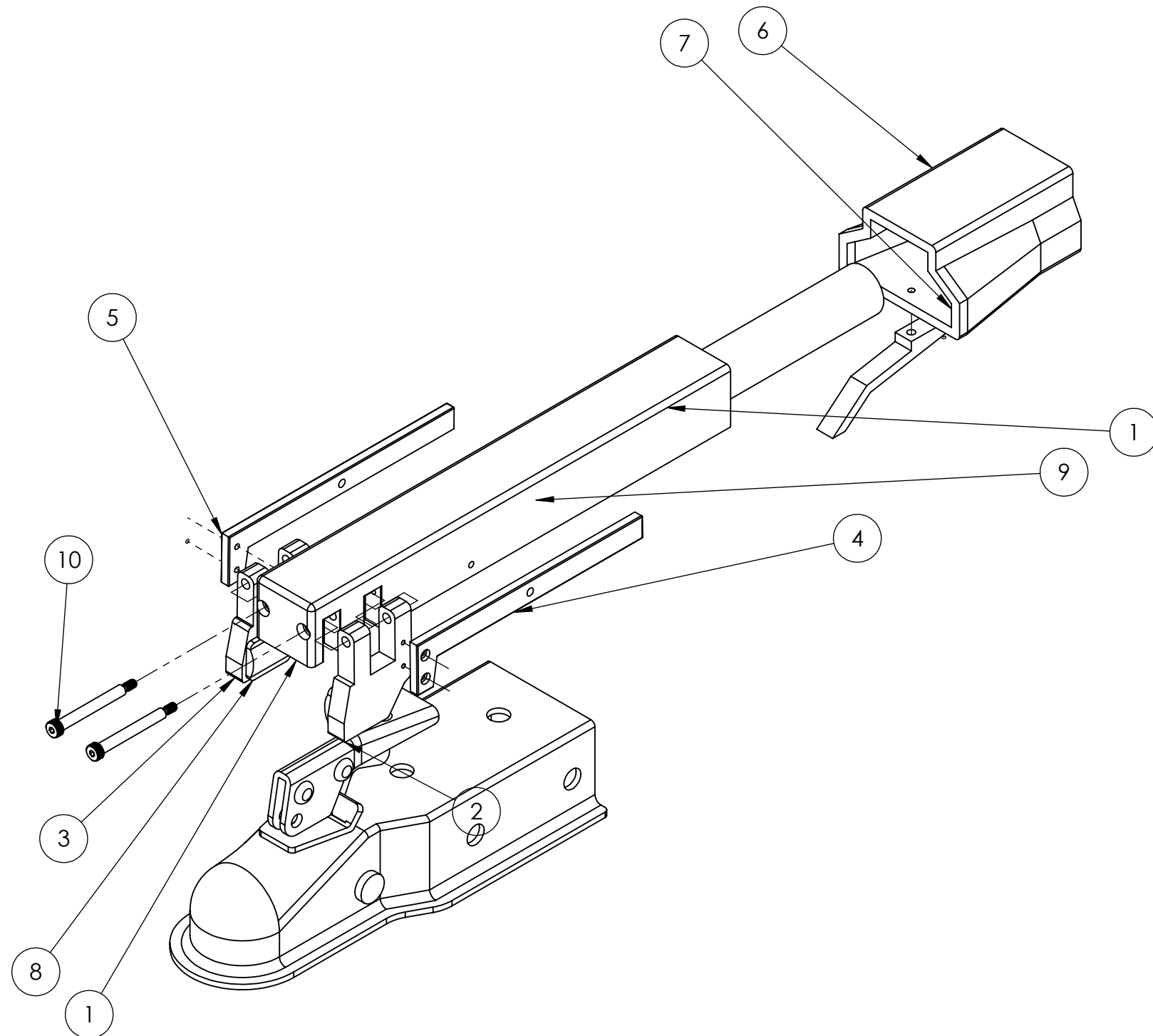
Lab Section:06
Dwg. #:TH1000

MATL: VARIOUS
Nxt Asb:TH0

RECEIVER WITH ACCESSORIES
Date:2/6/2019 Scale: 1=6

Drwn. By: M.SELNA (64 HITCH)
Chkd. By: ERIC RINGSRUD

ITEM NO.	PART NUMBER	DESCRIPTION	QTY.
1	TH3031	Coupler Lever Handle	1
2	TH3041	Left Flange Body	1
3	TH3043	Right Flange Body	1
4	TH3042	Left Wing	1
5	TH3044	Right Wing	1
6	TH3051	Collar	1
7	TH3052	Incline	1
8	TH3040	Pad	2
9	96605K32	Spring	1
10	90298A548_18-8 STAINLESS STEEL SHOULDER SCREW		2



Cal Poly Mechanical Engineering ME 429 - WTR 2019	Lab Section: 06	MATL: VARIOUS	Title: Tongue Lever	Drwn. By: JOSEPH HEARN
	Dwg. #: TH1010	Nxt Asb: TH0	Date: 02/04/2019 Scale: 1:5	Chkd. By: MAX SELNA

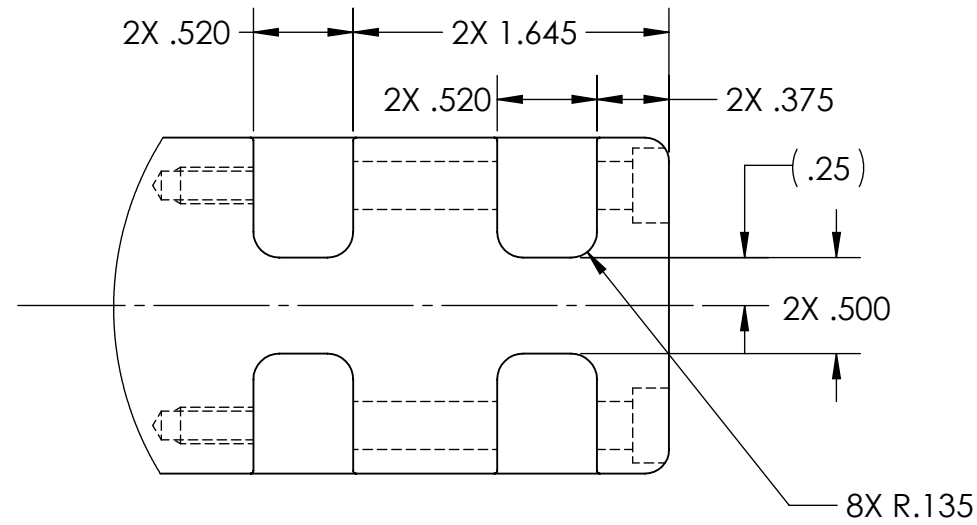
NOTES:
 SEE DETAIL C FOR TAPPED HOLE DEPTH REFERENCE
 UNLESS OTHERWISE SPECIFIED:

1) DIMENSIONS IN INCHES

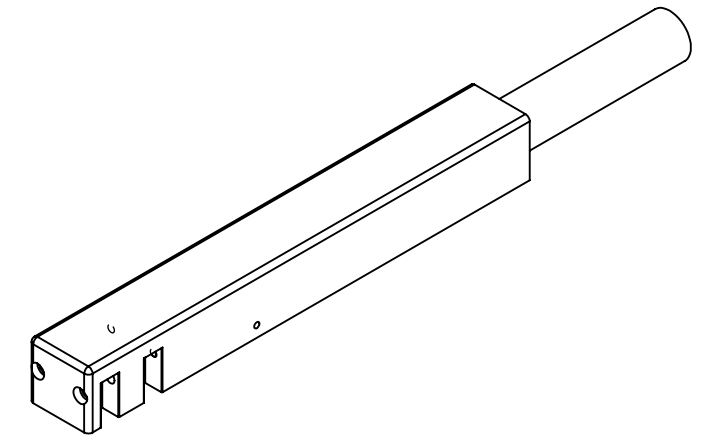
2) TOLERANCES:
 • X.XX ±.01
 • X.XXX ±.005
 • ANGLES ±.2°

3) BREAK ALL SHARP EDGES .005 MAX

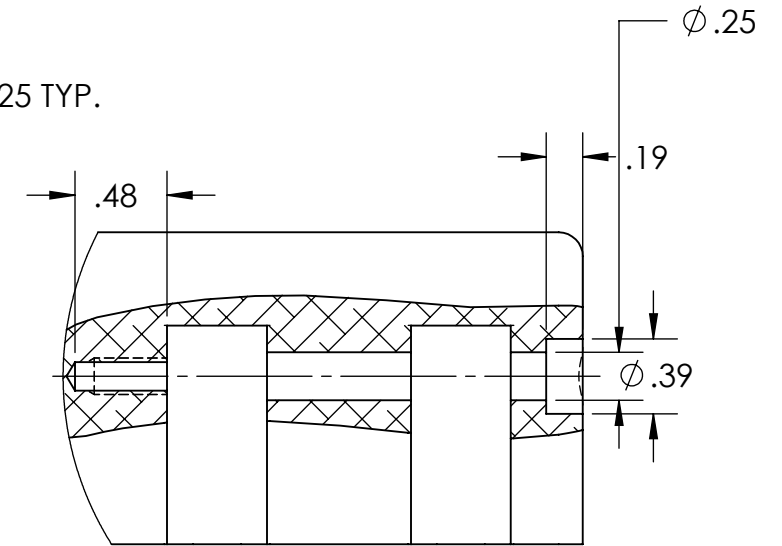
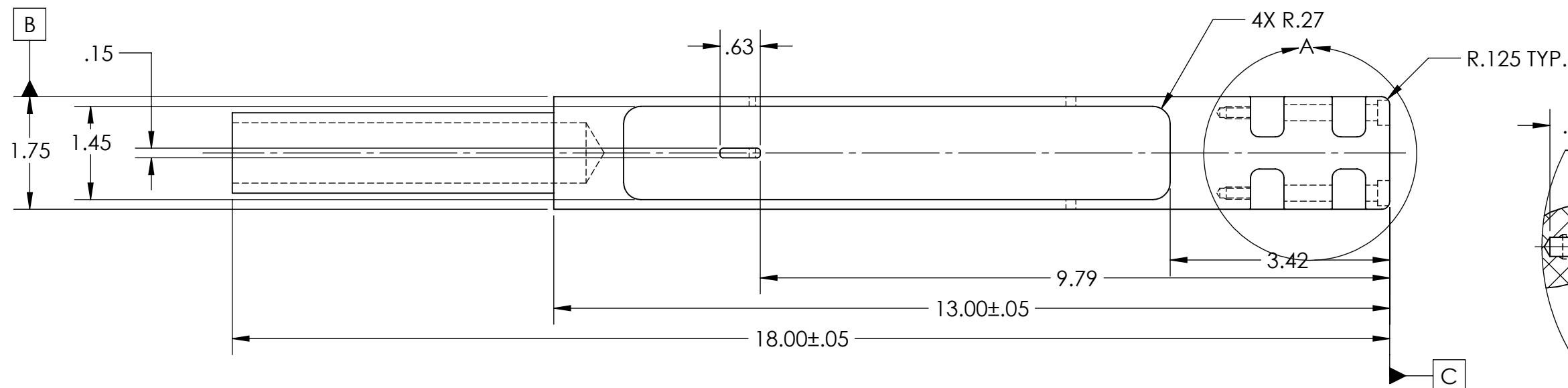
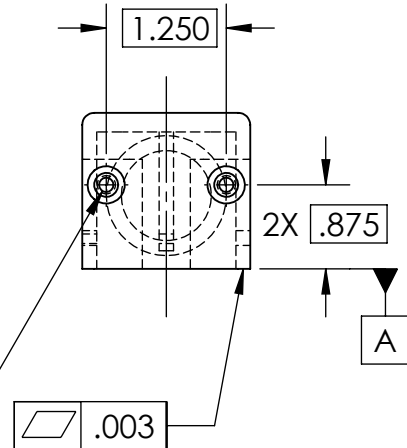
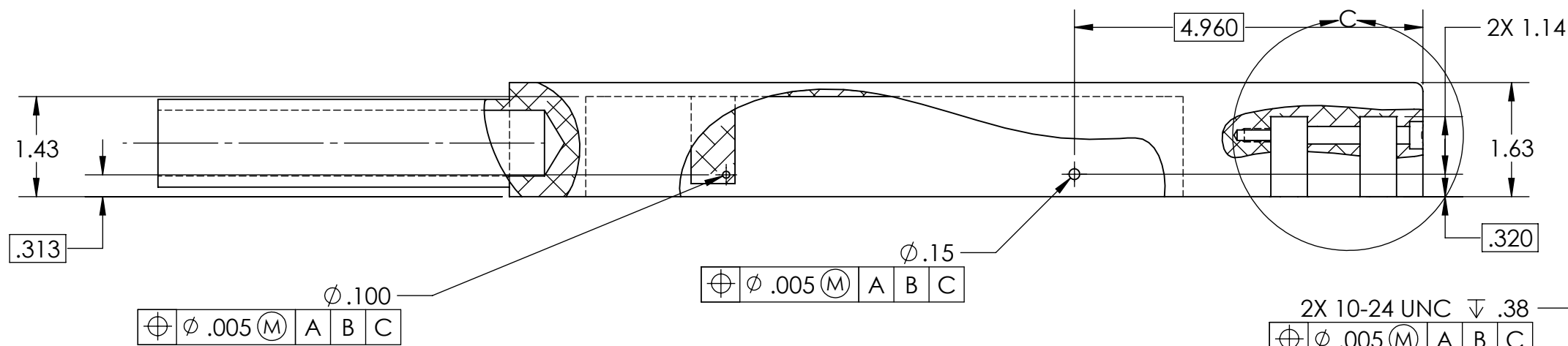
4) $63\sqrt{\text{FAO}}$



DETAIL A
 SCALE 1:1



SCALE 1:4



DETAIL C
 SCALE 1:1

Cal Poly Mechanical Engineering ME 429 - WTR 2019	Lab Section: 06 Dwg. #:TH3031	MATL: 6061 AL Nxt Asb:TH1010	Title:COUPLER LEVER HANDLE Date:02/04/2019	Scale: 1:2	Drwn. By: JOSEPH HEARN Chkd. By: MAX SELNA
--	----------------------------------	---------------------------------	---	------------	---

NOTES:
UNLESS OTHERWISE SPECIFIED:

1) DIMENSIONS IN INCHES

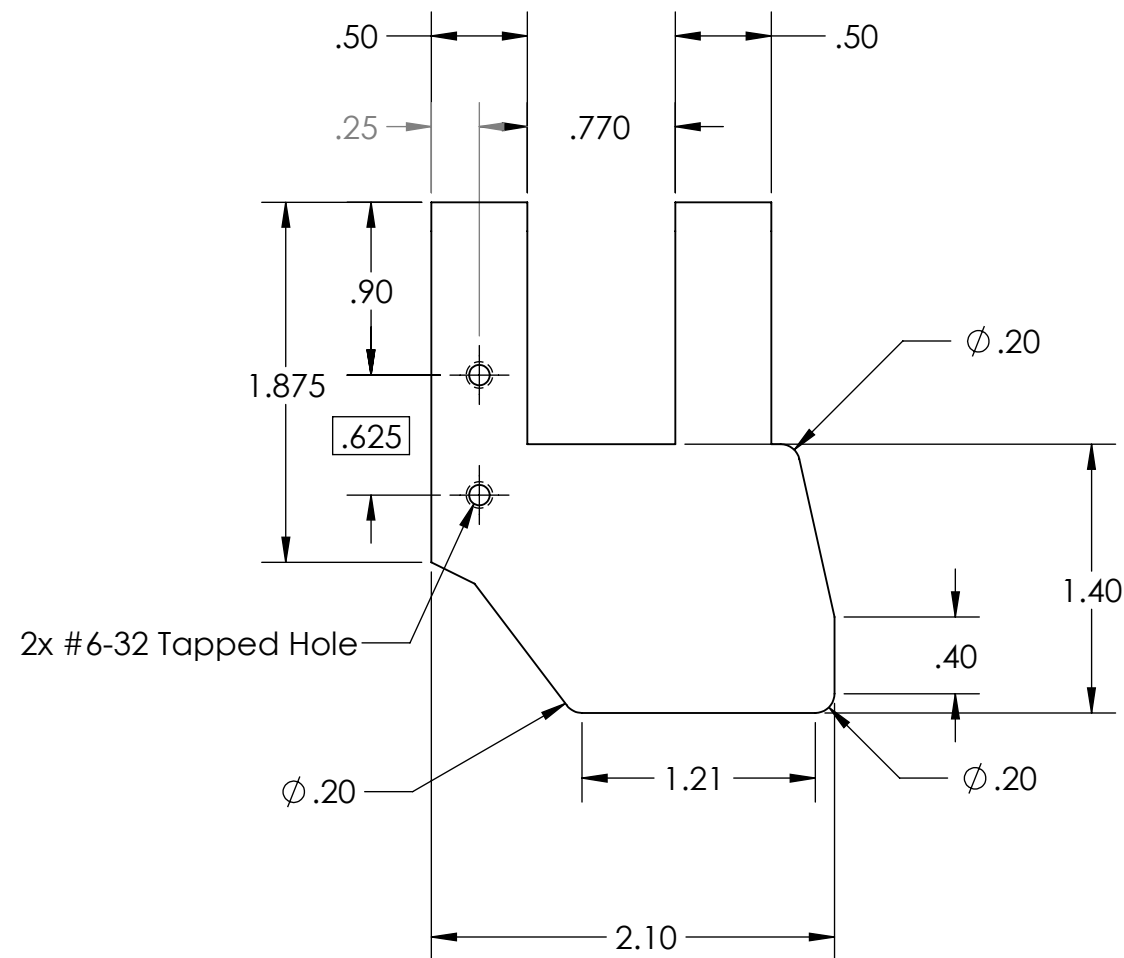
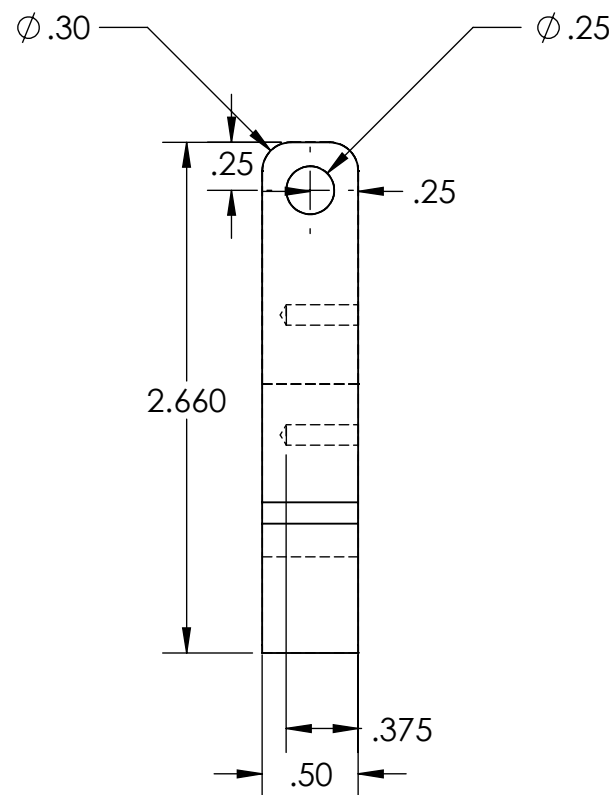
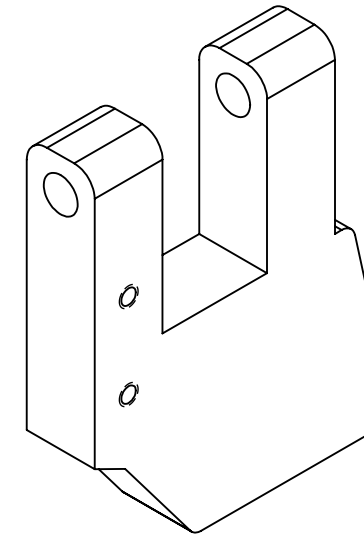
2) TOLERANCES:

- X.XX ±.01
- X.XXX ±.005
- ANGLES ±.2°

3) BREAK ALL SHARP EDGES .005 MAX

4) $63\sqrt{\text{FAO}}$

5) FOR TH3041 DRILL TAPED HOLES IN THE OTHER SIDE



Cal Poly Mechanical Engineering ME 429 - WTR 2019	Lab Section:06 DWG.#: TH3041	MATL: 6061 AL Nxt Asb:TH1010	Title: FLANGE BODY Date:02/04/2019	Scale: 1:1	Drwn. By: JOSEPH HEARN Chkd. By: MAX SELNA
--	---------------------------------	---------------------------------	---------------------------------------	------------	---

NOTES:
UNLESS OTHERWISE SPECIFIED:

1) DIMENSIONS IN INCHES

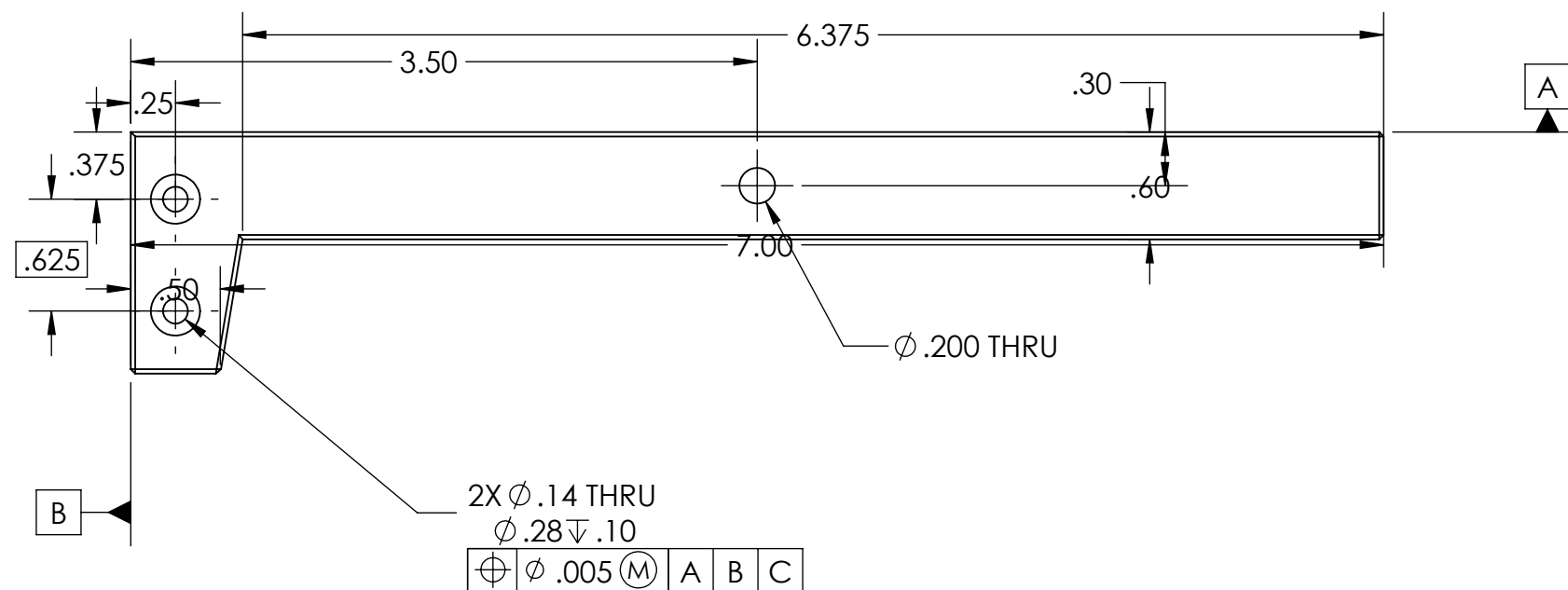
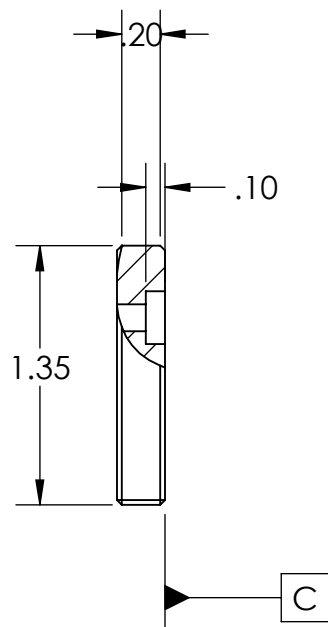
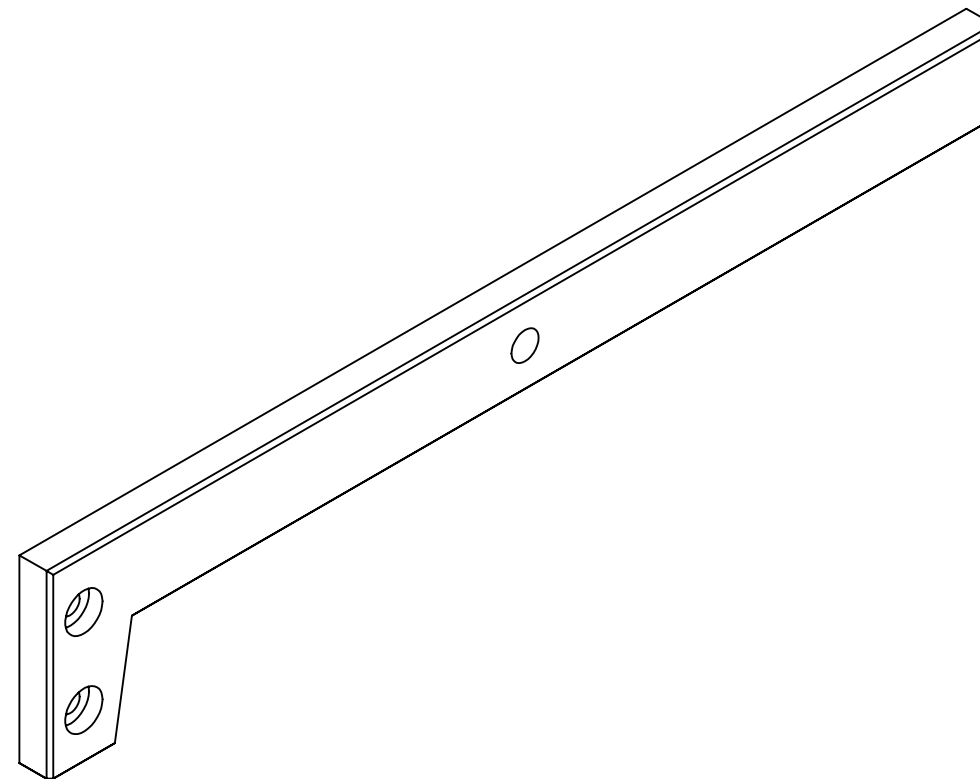
2) TOLERANCES:

- X.XX ±.01
- X.XXX ±.005
- ANGLES ±.2°

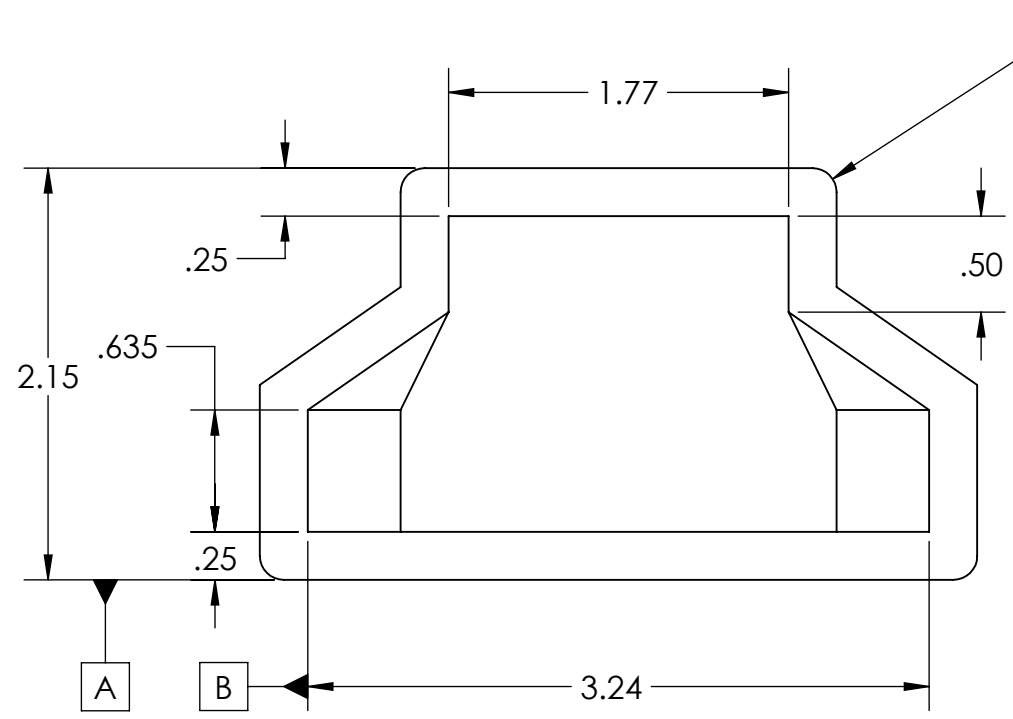
3) BREAK ALL SHARP EDGES .005 MAX

4) $63\sqrt{\text{FAO}}$

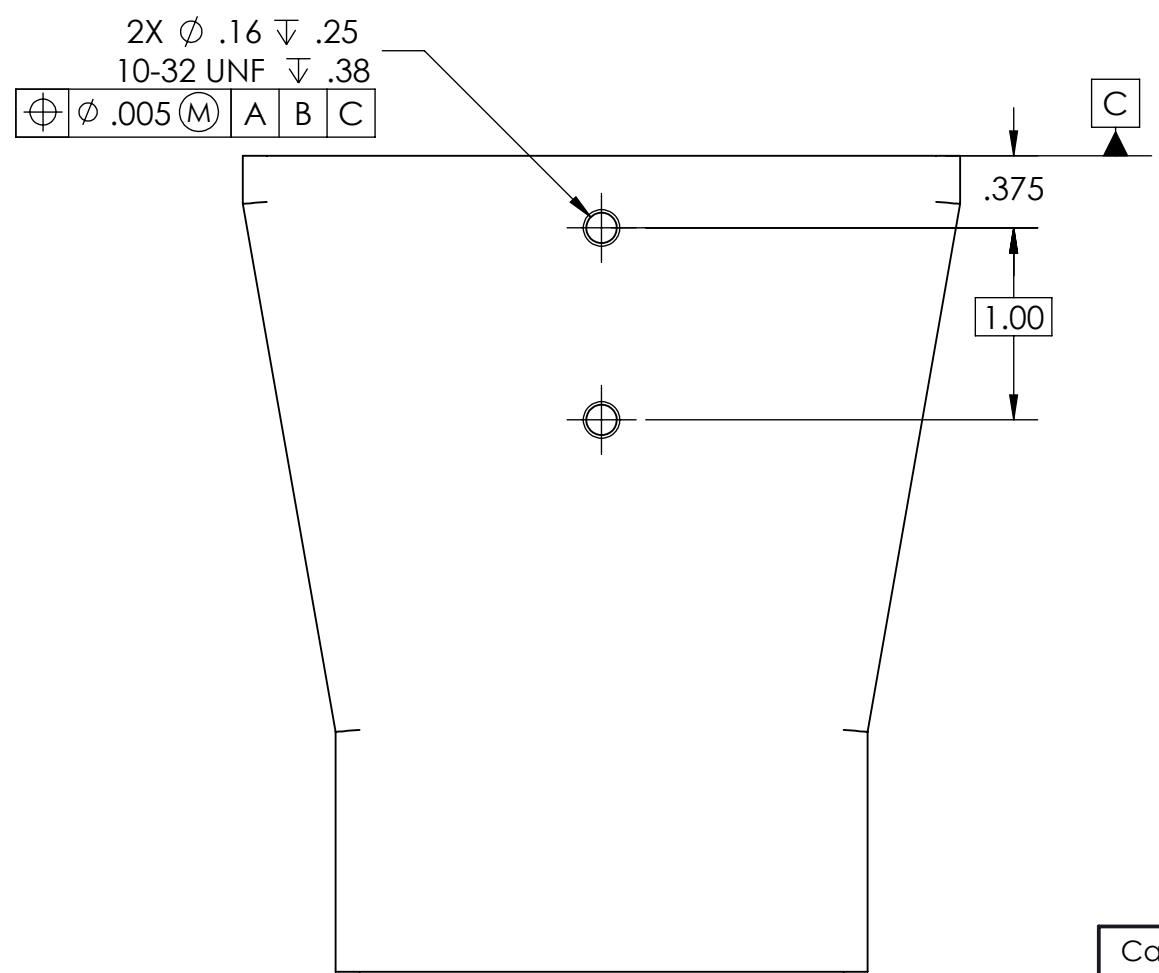
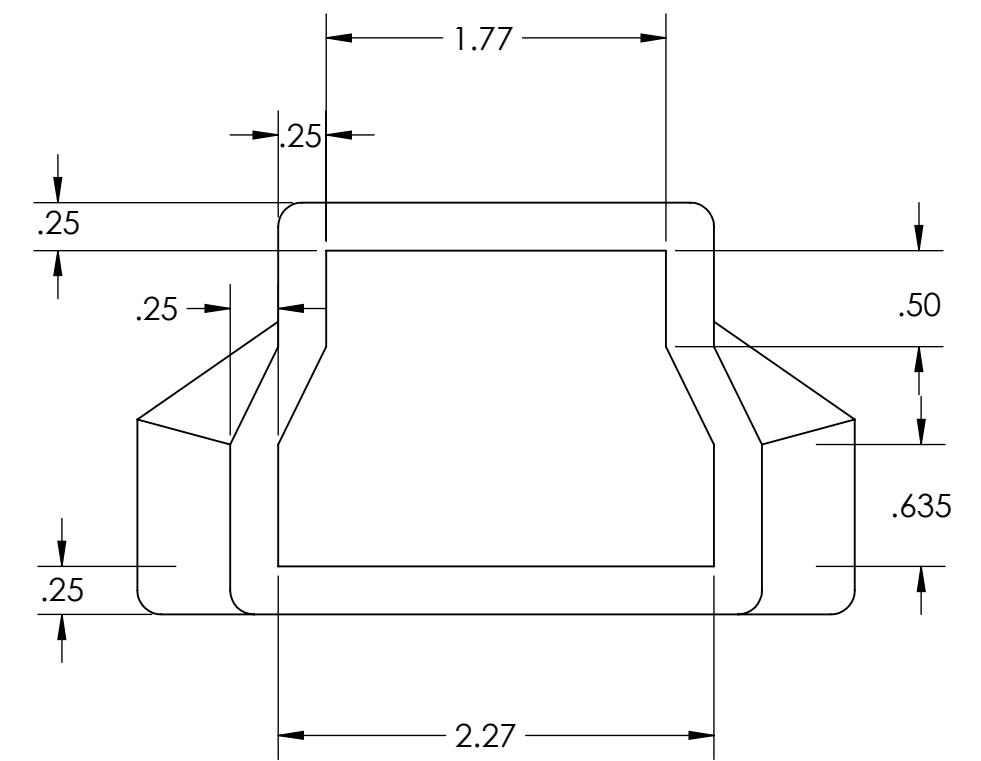
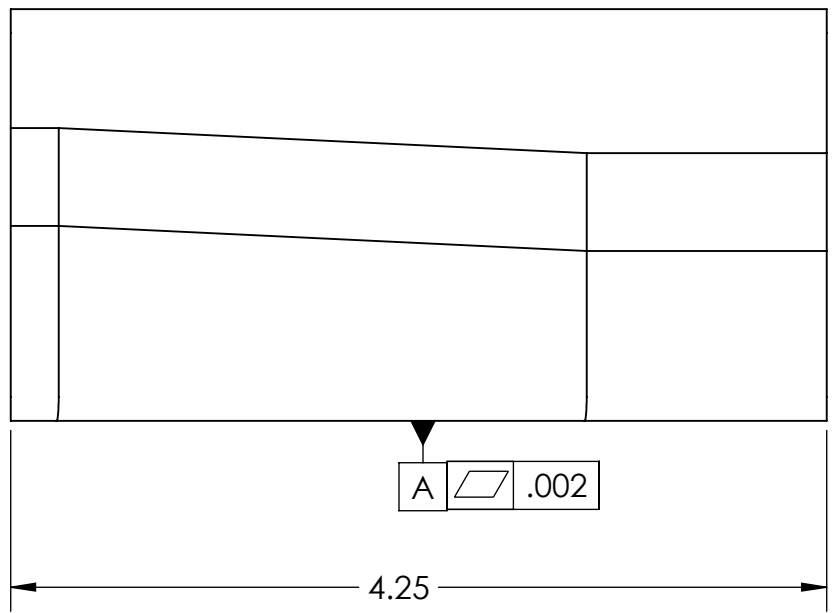
5) FOR TH3044, COUNTERSINK THE OTHER SIDE



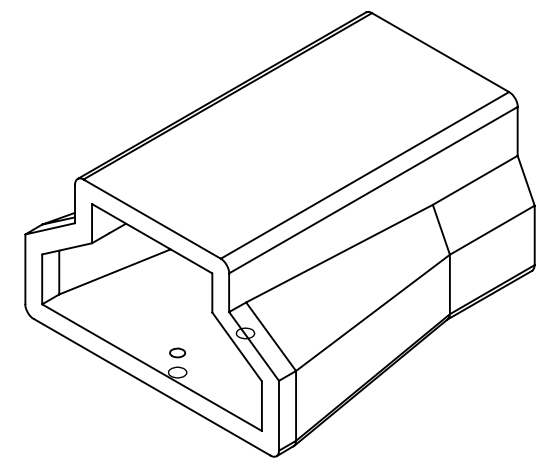
Cal Poly Mechanical Engineering ME 429 - WTR 2019	Lab Section:06	MATL: MILD STEEL	Title:WING	Drwn. By: JOSEPH HEARN
	Dwg. #:TH3042	Nxt Asb:TH1010	Date: 02/04/2019 Scale: 1:1	Chkd. By: MAX SELNA



4X R.125

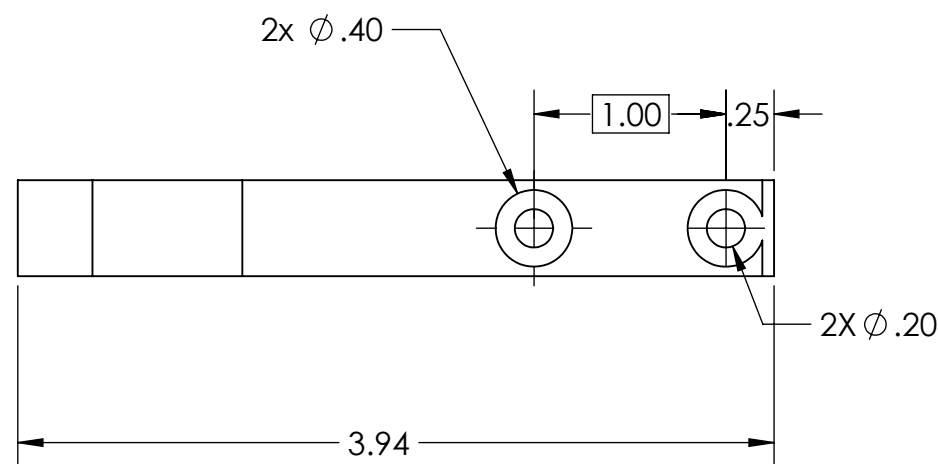
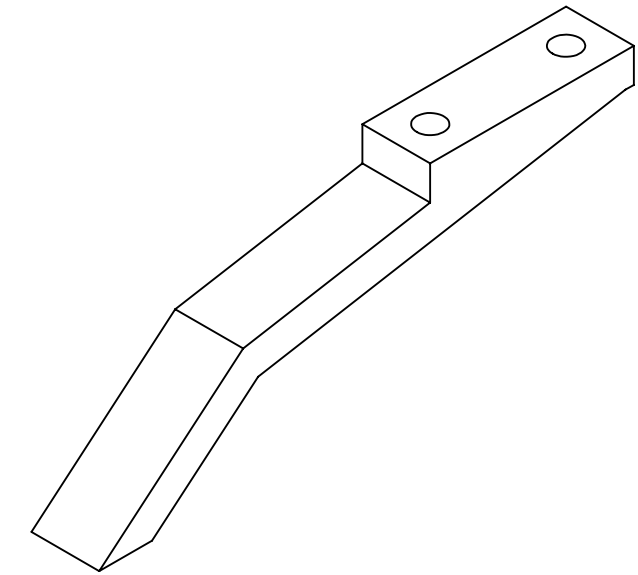
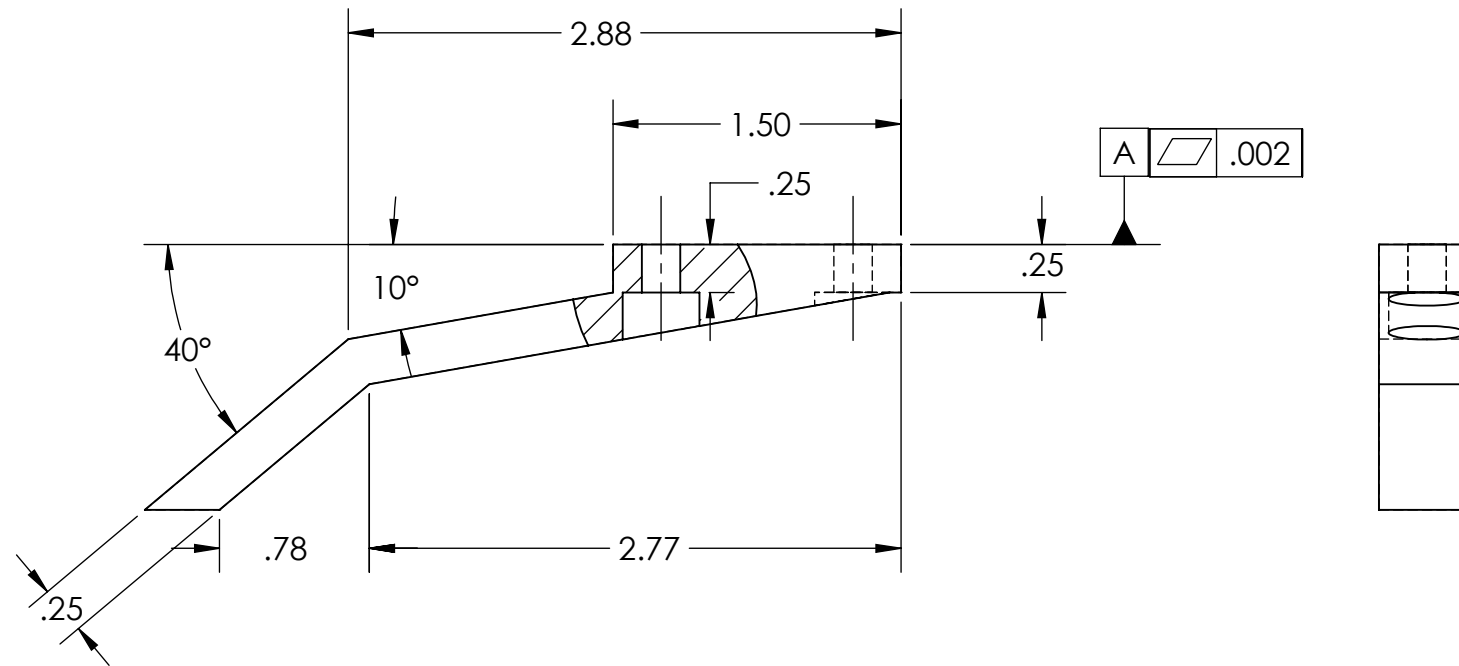
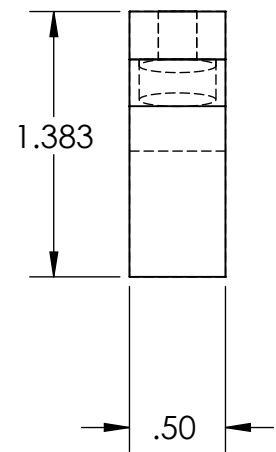


- NOTES:
UNLESS OTHERWISE SPECIFIED:
- 1) DIMENSIONS IN INCHES
 - 2) TOLERANCES:
 - X.XX ±.01
 - X.XXX ±.005
 - ANGLES ±.2°
 - 3) BREAK ALL SHARP EDGES .005 MAX
 - 4) 63√FAO



SCALE: 1:2

Cal Poly Mechanical Engineering ME 429 - WTR 2019	Lab Section:06	MATL: 6061 AL	Title: COLLAR		Drwn. By: JOSEPH HEARN
	Dwg. #:TH3051	Nxt Asb: TH1010	Date:02/04/19	Scale:1:1	Chkd. By: MAX SELNA



NOTES:
UNLESS OTHERWISE SPECIFIED:

1) DIMENSIONS IN INCHES

2) TOLERANCES:
• X.XX ±.01
• X.XXX ±.005
• ANGLES ±.2°

3) BREAK ALL SHARP EDGES .005 MAX

4) $63\sqrt{\text{FAO}}$

Cal Poly Mechanical Engineering
ME 429 - WTR 2019

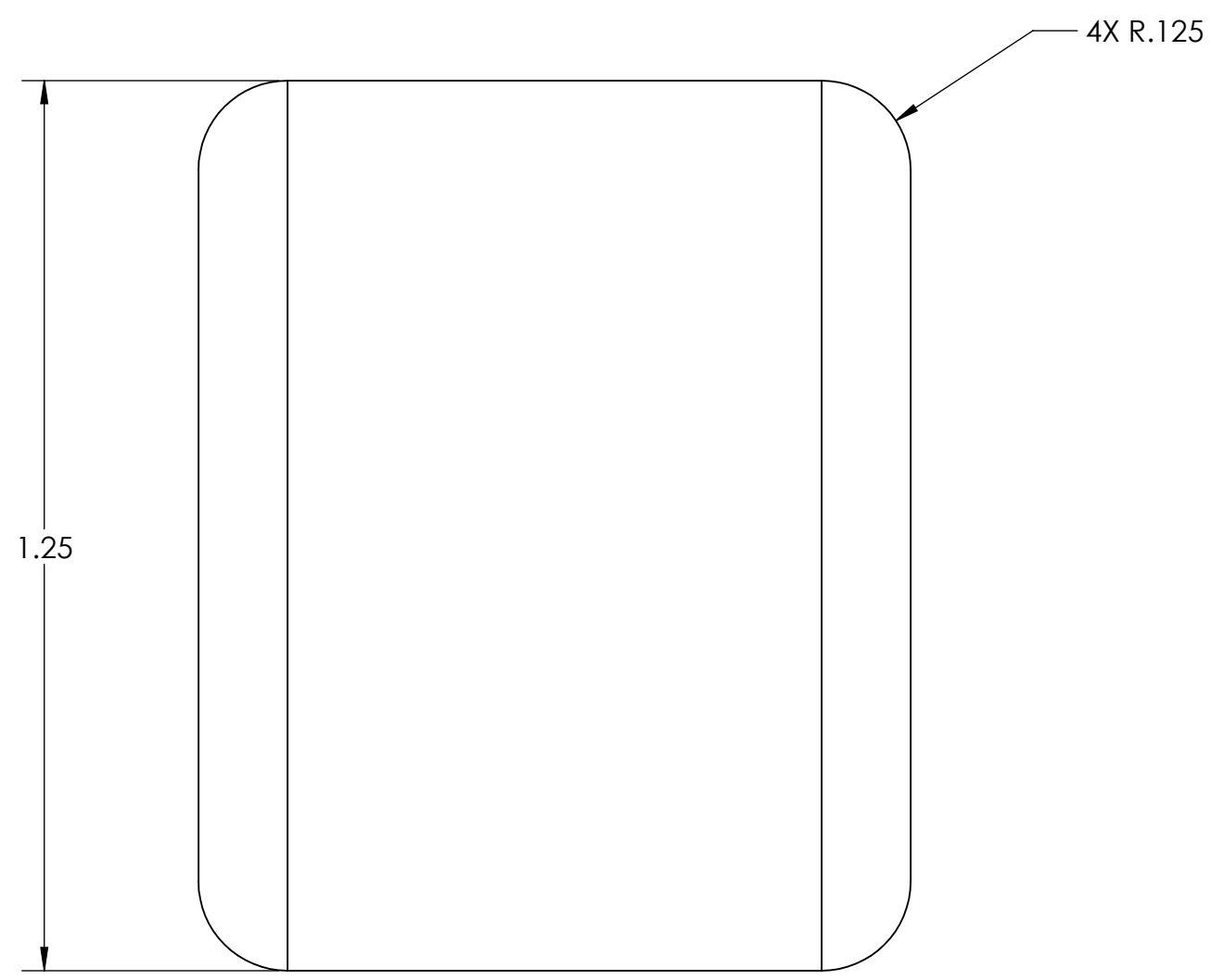
Lab Section:06
Dwg. #: TH3052

MATL: 6061 AL
Nxt Asb:TH1010

Title: INCLINE
Date:02/06/2019

Scale: 1:1

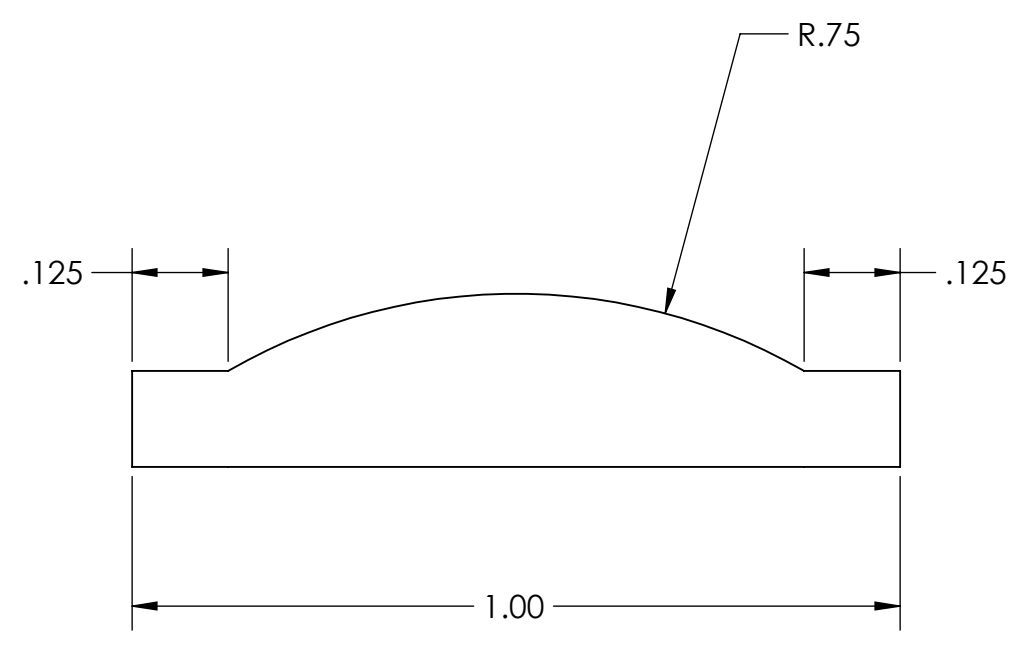
Drwn. By:JOSEPH HEARN
Chkd. By: ME STAFF



NOTES:
UNLESS OTHERWISE SPECIFIED:

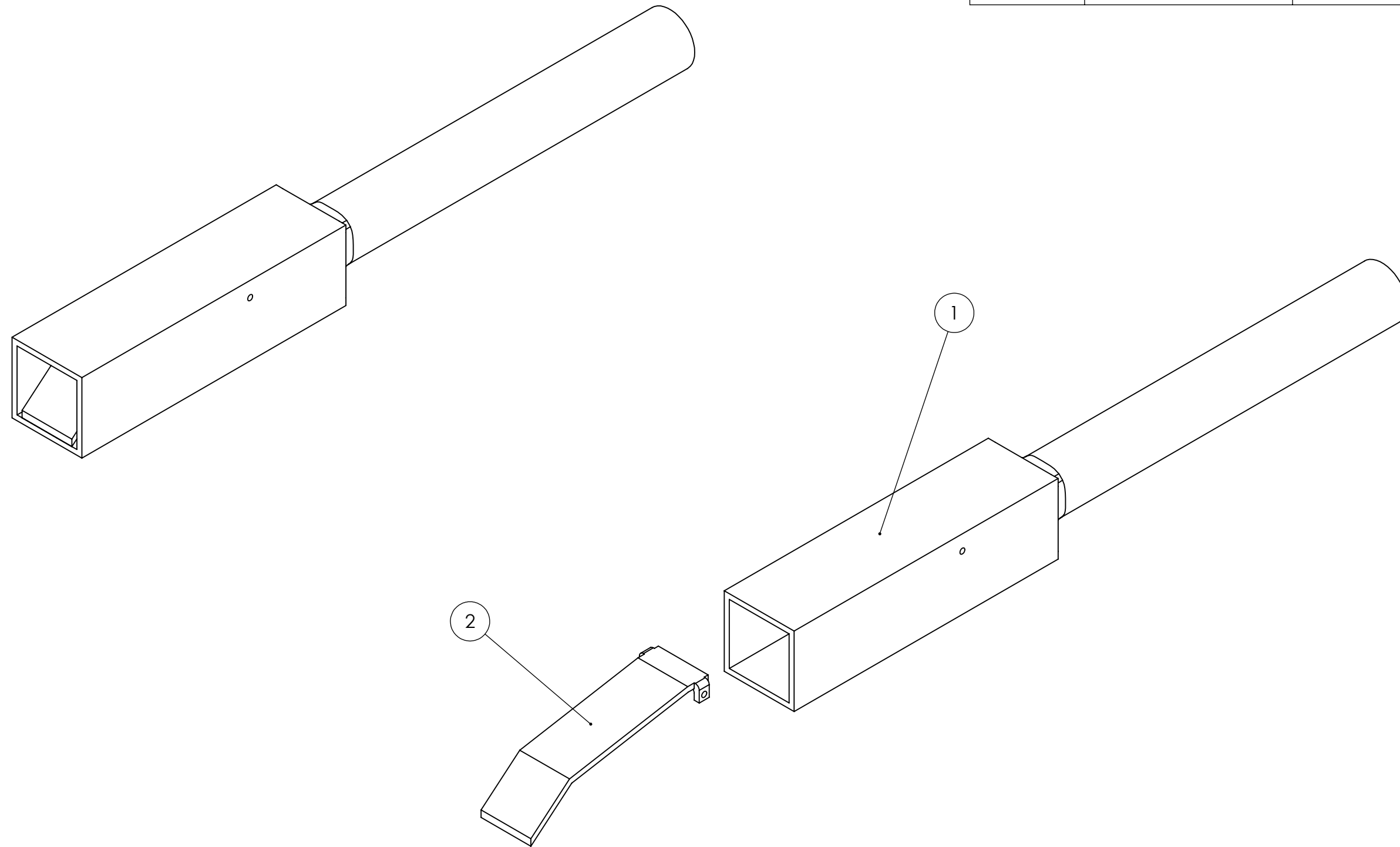
- 1) DIMENSIONS IN INCHES
- 2) TOLERANCES:
 - X.XX ±.01
 - X.XXX ±.005
 - ANGLES ±.2°
- 3) BREAK ALL SHARP EDGES .005 MAX

4) $63\sqrt{\text{FAO}}$



Cal Poly Mechanical Engineering ME 429 - WTR 2019	Lab Section:06	MATL:NEOPRENE	Title: PAD		Drwn. By: JOSEPH HEARN
	Dwg. #: TH3040	Nxt Asb:TH1010	Date: 02/06/19	Scale:4:1	Chkd. By: ME STAFF

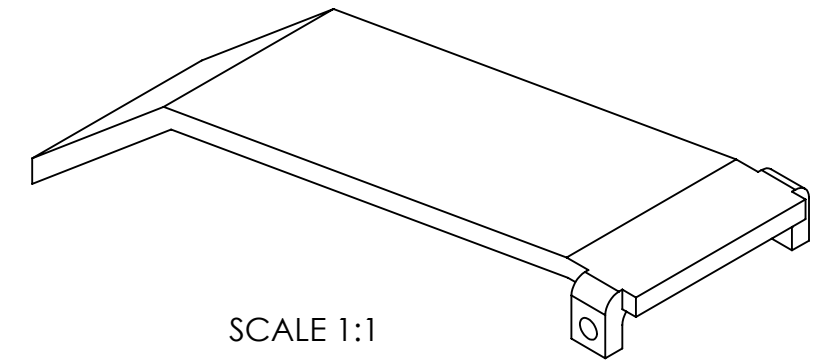
ITEM NO.	PART NUMBER	DESCRIPTION	QTY.
1	Mark 2 Main Body		1
2	Incline mark 2		1



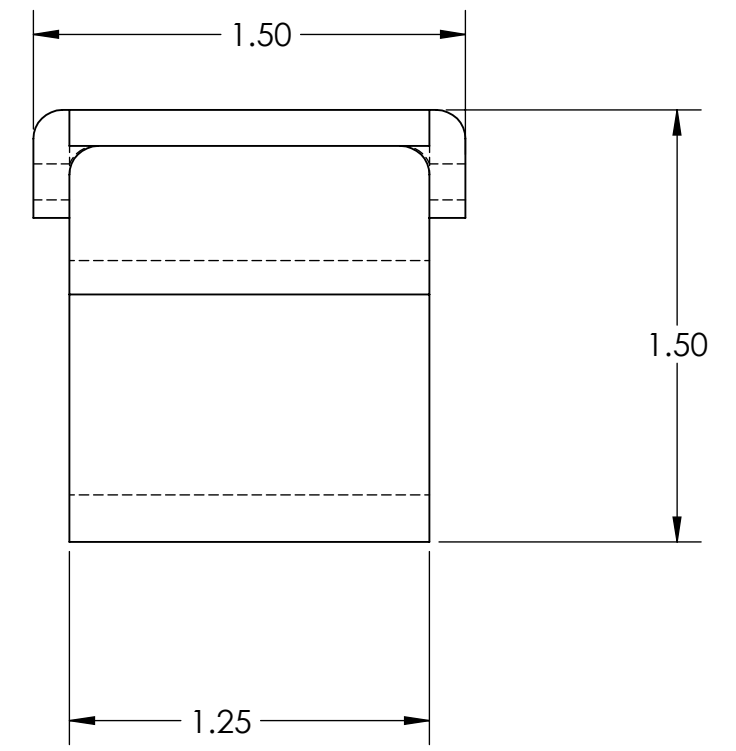
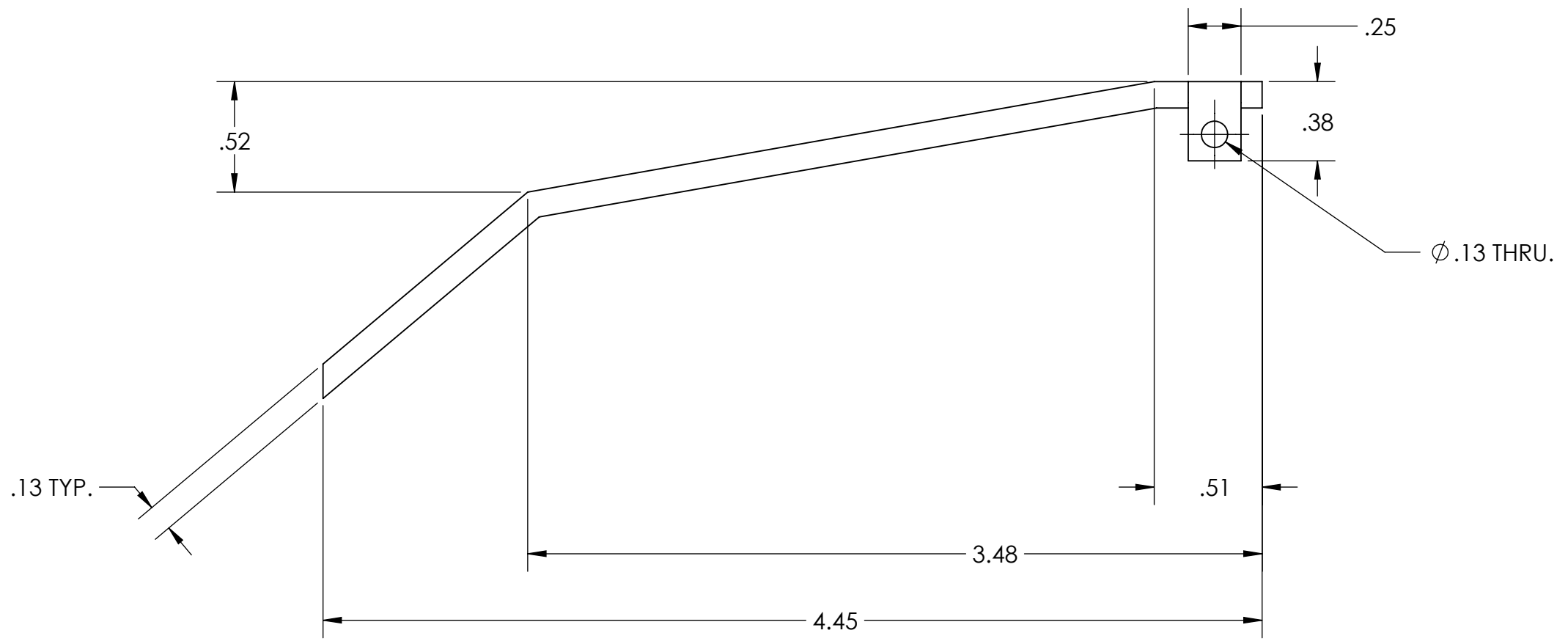
Cal Poly Mechanical Engineering ME 430 - SPRING 2019	Lab Section: 06	MATL: N/A	Title: TONGUE LEVER (B)	Drwn. By: MAX SELNA
	Dwg. #: TH1020	Nxt Asb: TH0	Date:05/28/2019 Scale: 1:2	Chkd. By: ERIC RINGSRUD

NOTES:
UNLESS OTHERWISE SPECIFIED:

- 1) DIMENSIONS IN INCHES
- 2) TOLERANCES:
 - X.XX ±.01
 - X.XXX ±.005
 - ANGLES ±.2°
- 3) BREAK ALL SHARP EDGES .005 MAX
- 4) $63\sqrt{\text{FAO}}$



SCALE 1:1



Cal Poly Mechanical Engineering ME 430 - SPRING 2019	Lab Section: 06	MATL: 6061 T6	Title: INCLINE (B)	Drwn. By: MAX SELNA
	Dwg. #: TH2061	Nxt Asb: TH1020	Date:05/28/2019	Scale: 3:2
				Chkd. By: ERIC RINGSRUD

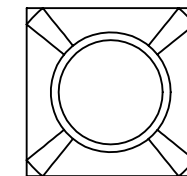
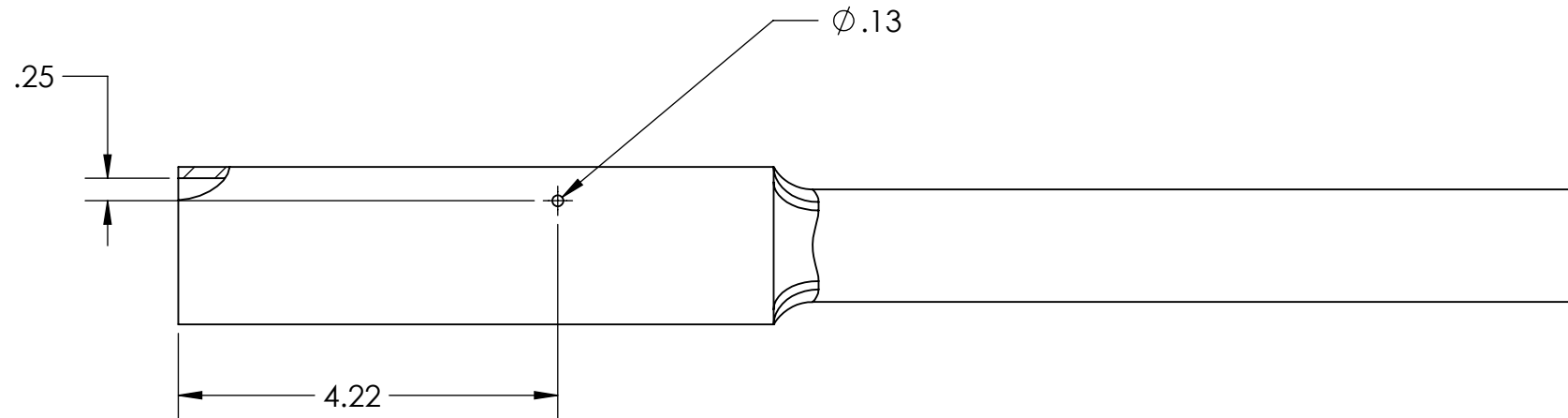
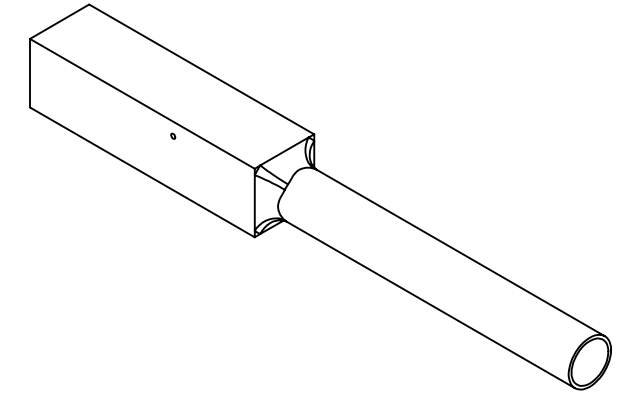
NOTES:
UNLESS OTHERWISE SPECIFIED:

1) DIMENSIONS IN INCHES

- 2) TOLERANCES:
- X.XX \pm .01
 - X.XXX \pm .005
 - ANGLES \pm .2°

3) BREAK ALL SHARP EDGES .005 MAX

4) $63\sqrt{\text{FAO}}$



Cal Poly Mechanical Engineering ME 430 - SPRING 2019	Lab Section: 06 Dwg. #: TH2061	MATL: 6061 T6 Nxt Asb: TH1020	Title: INCLINE (B) Date: 05/28/2019	Scale: 1:2	Drwn. By: MAX SELNA Chkd. By: ERIC RINGSRUD
---	-----------------------------------	----------------------------------	--	------------	--

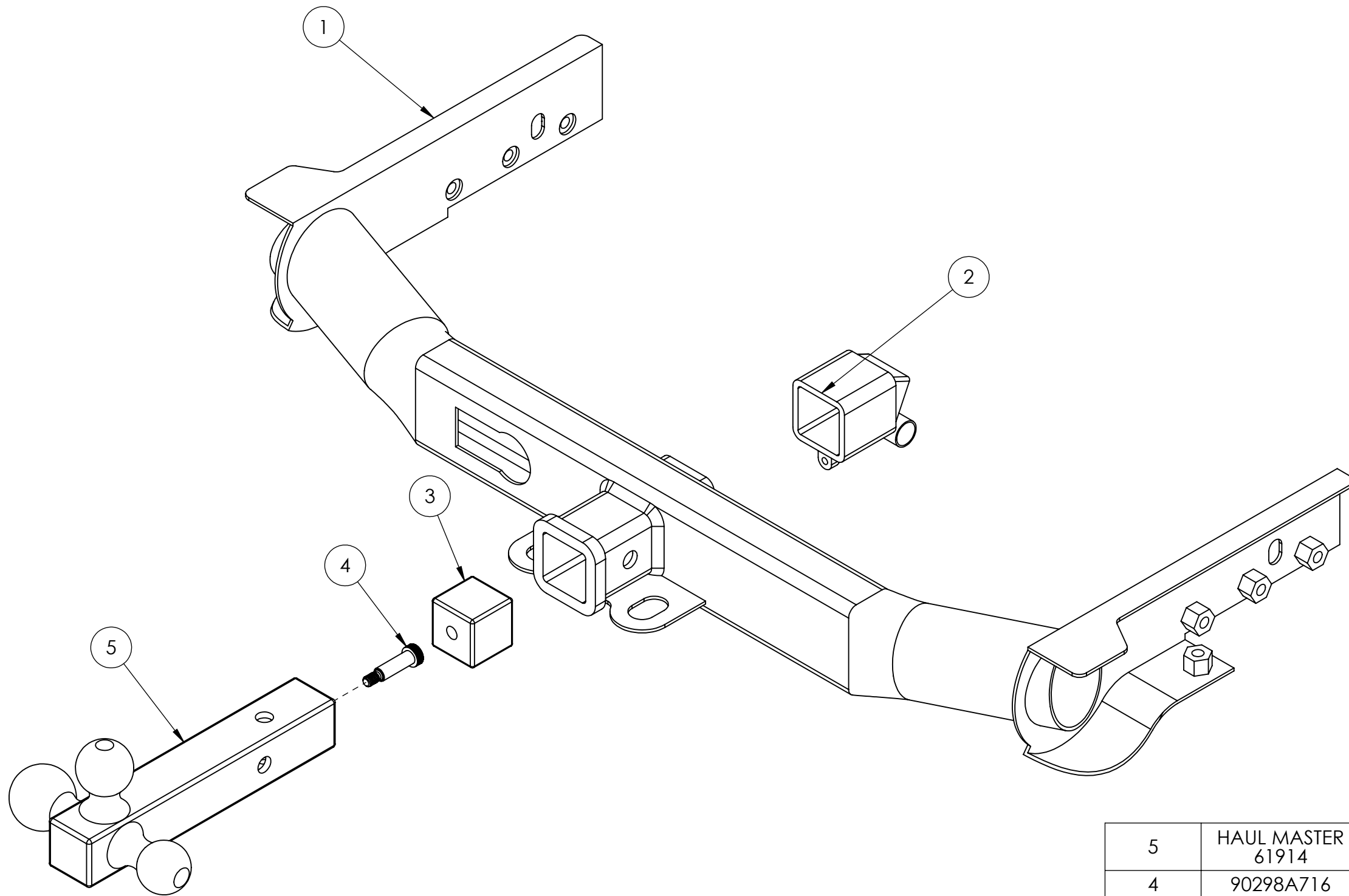
NOTES:
UNLESS OTHERWISE SPECIFIED:

1) DIMENSIONS IN INCHES

2) TOLERANCES:
 • .XX ± .01
 • .XXX ± .005
 • ANGLES ± 2°

3) BREAK ALL SHARP EDGES .005 MAX

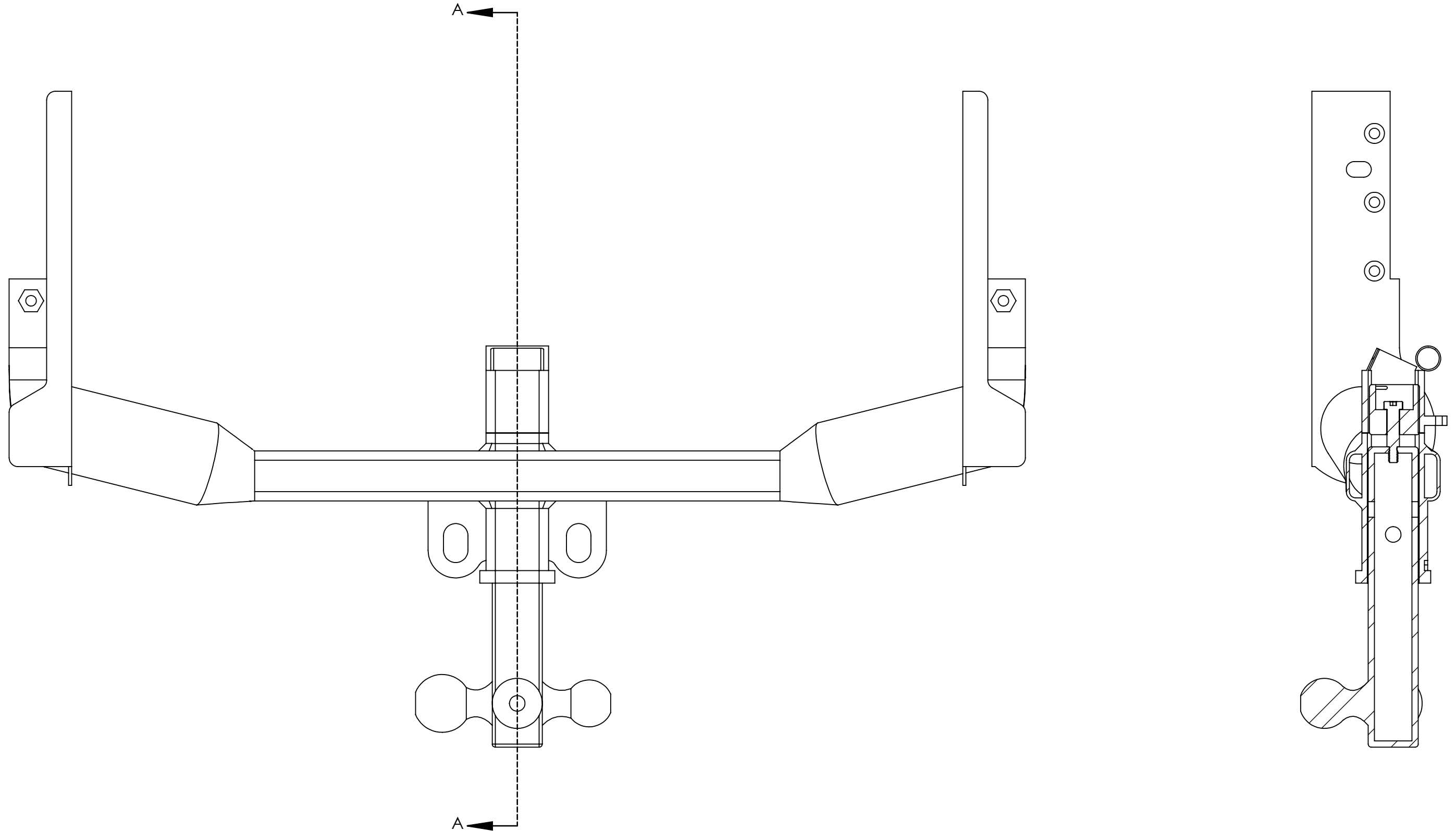
4) $63 \sqrt{\text{FAO}}$



5	HAUL MASTER 61914	MODIFIED TRIPLE BALL HITCH	1
4	90298A716	SHOULDER BOLT	1
3	TH2001	SLIDING BLOCK	1
2	TH2002	RECIEVER EXTENSION	1
1	TH1000	2014 JEEP GRAND CHEROKEE HITCH RECIEVER	1
ITEM NO.	PART NUMBER	DESCRIPTION	QTY.

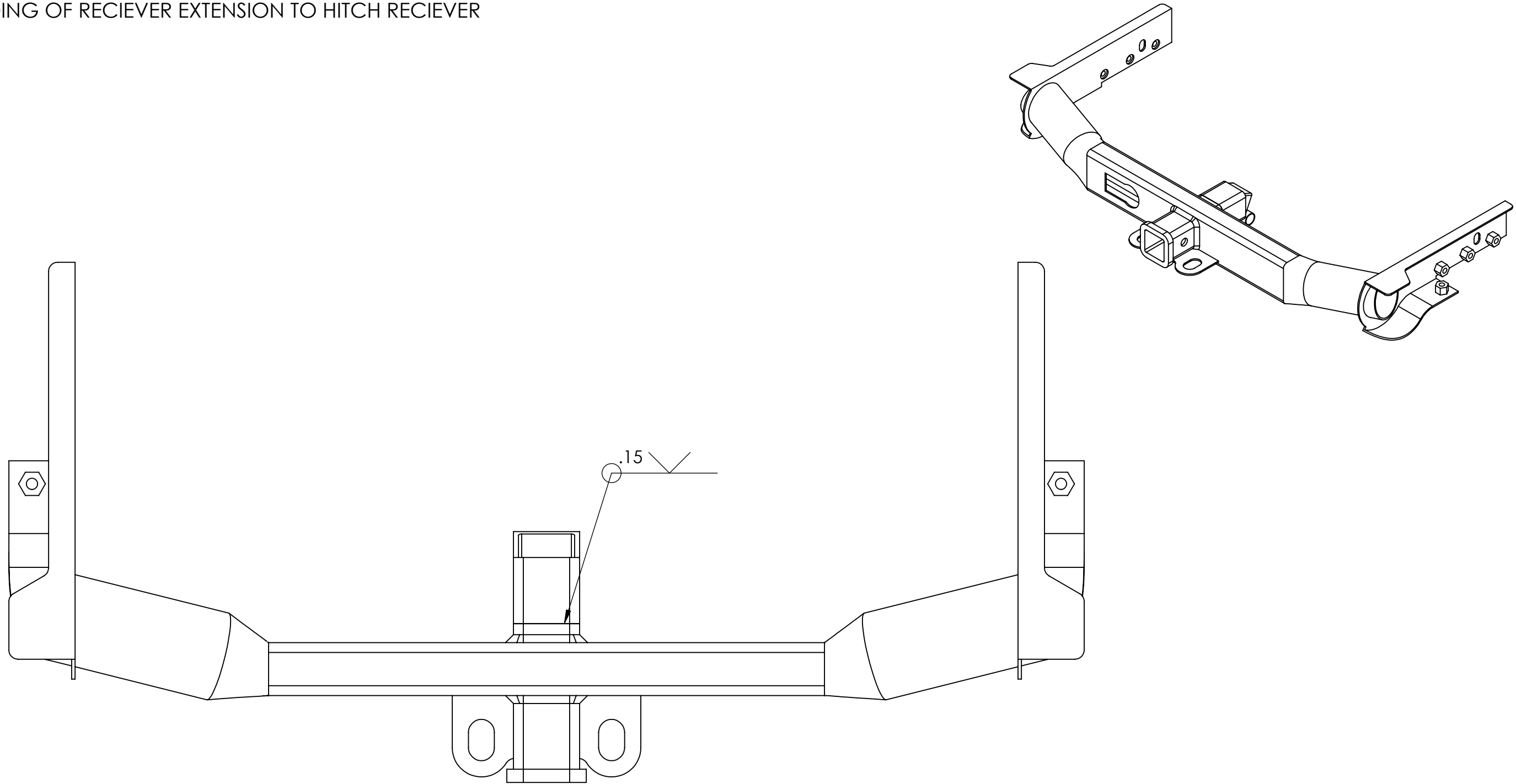
Cal Poly Mechanical Engineering ME 429 - WINTER 2019	Lab Section: 06	MATL: N/A	Title: ROTATING HITCH ASSEMBLY	Drwn. By: ERIC RINGSRUD
	Dwg. #: TH2000	Nxt Asb: TH1000	Date: 02/01/2019 Scale: 1:4	Chkd. By: MAX SELNA

HITCH IN TOWING POSITION



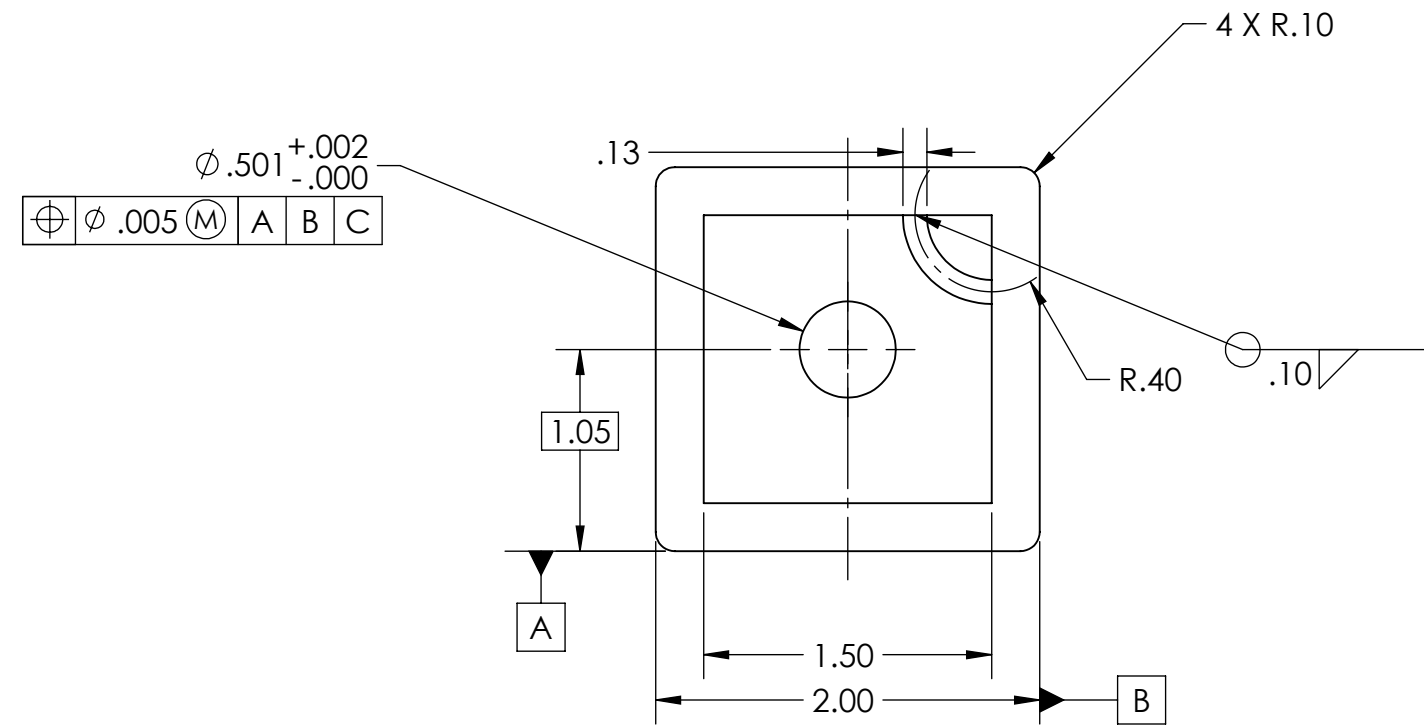
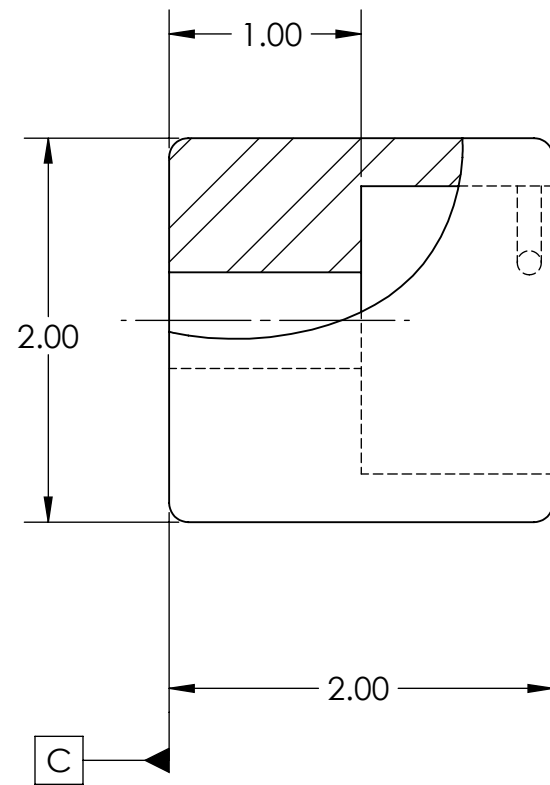
Cal Poly Mechanical Engineering ME 429 - WINTER 2019	Lab Section: 06	MATL: MILD STEEL	Title: ROTATING HITCH ASSEMBLY	Drwn. By: ERIC RINGSRUD
	Dwg. #:	Nxt Asb:	Date: 2/1/2019	Scale: 1:4
				Chkd. By: MAX SELNA

WELDING OF RECIEVER EXTENSION TO HITCH RECIEVER



Cal Poly Mechanical Engineering ME 429 - WINTER 2019	Lab Section: 06	MATL: MILD STEEL	Title: ROTATING HITCH ASSEMBLY	Drwn. By: ERIC RINGSRUD
	Dwg. #:	Nxt Asb:	Date: 2/1/2019	Scale: 1:4
				Chkd. By: MAX SELNA

TH2001 SLIDING BLOCK DETAIL DRAWING



Cal Poly Mechanical Engineering
ME 429 - WINTER 2019

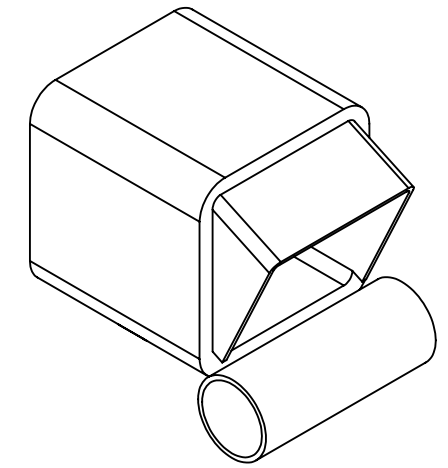
Lab Section: 06
Dwg. #: TH3001

MATL: MILD STEEL
Nxt Asb: TH2000

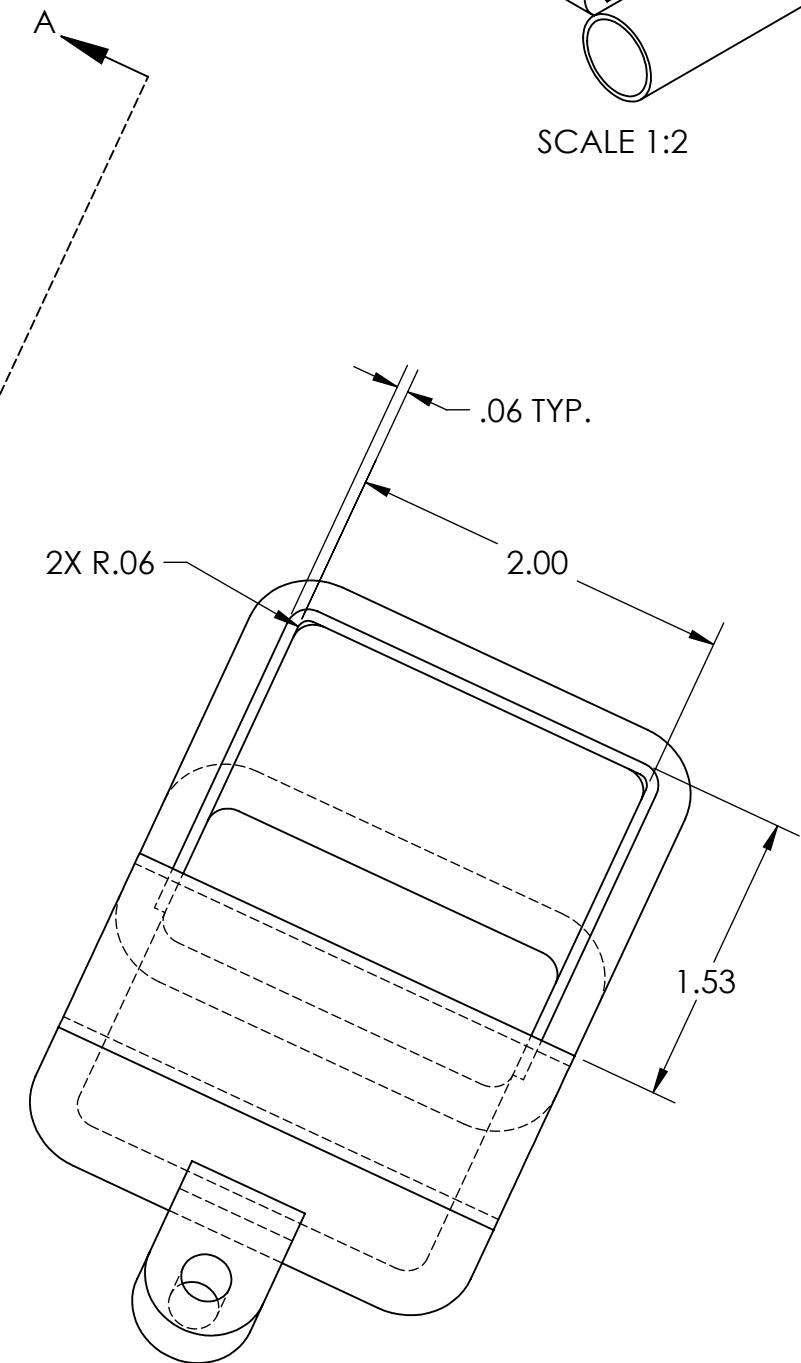
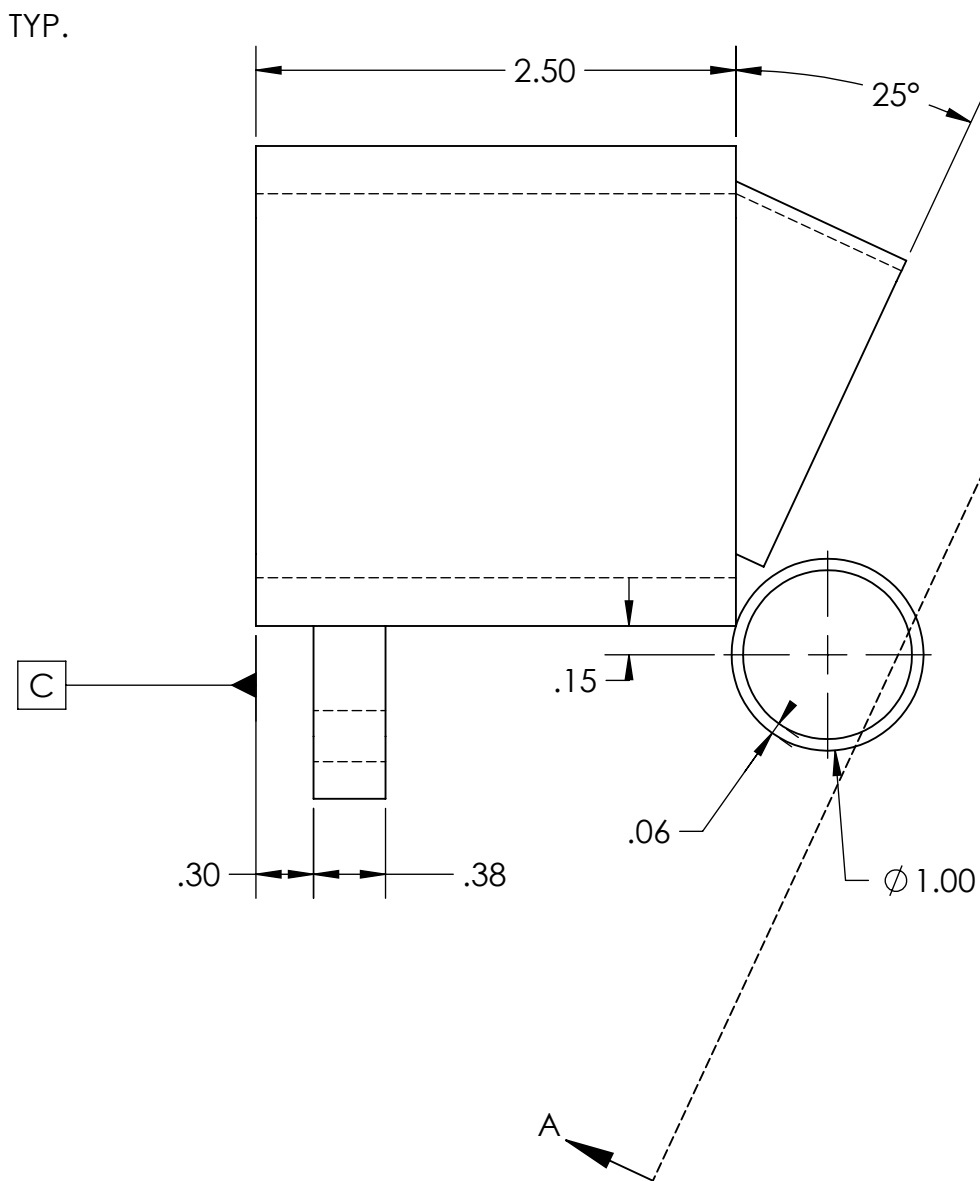
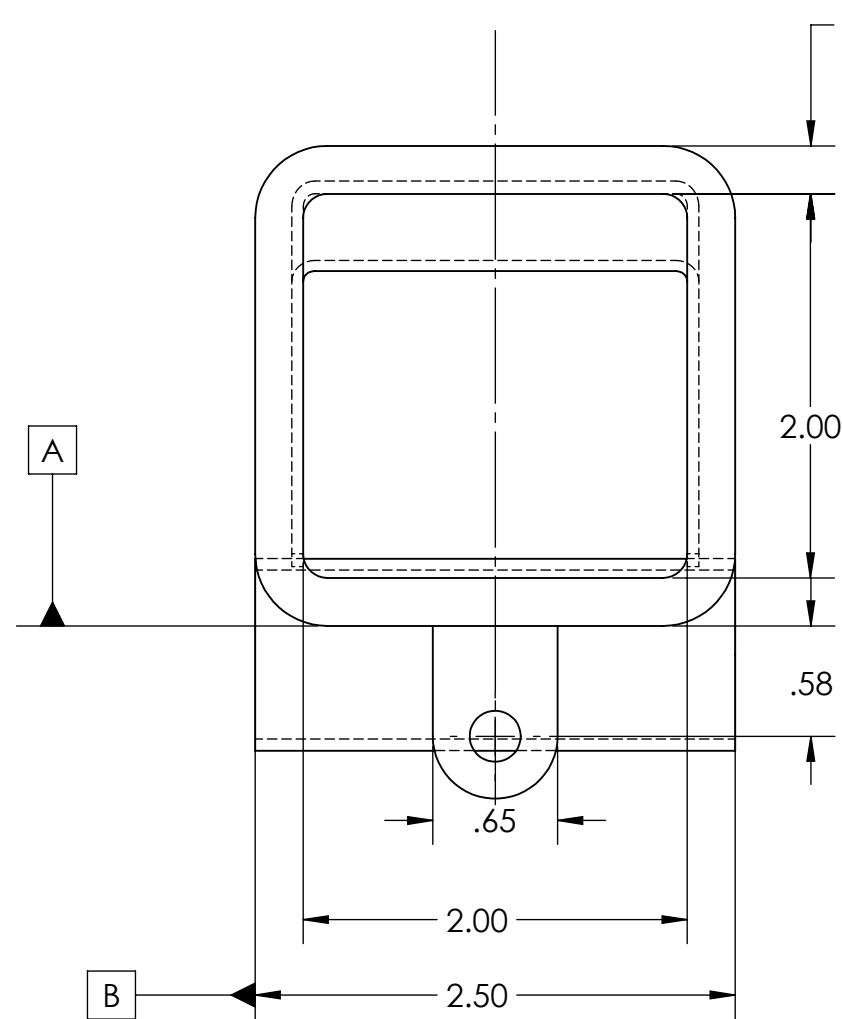
Title: ROTATING HITCH ASSEMBLY
Date: 02/01/2019
Scale: 1:1

Drwn. By: ERIC RINGSRUD
Chkd. By: MAX SELNA

TH2002 HITCH RECIEVER EXTENSION DETAIL DRAWING

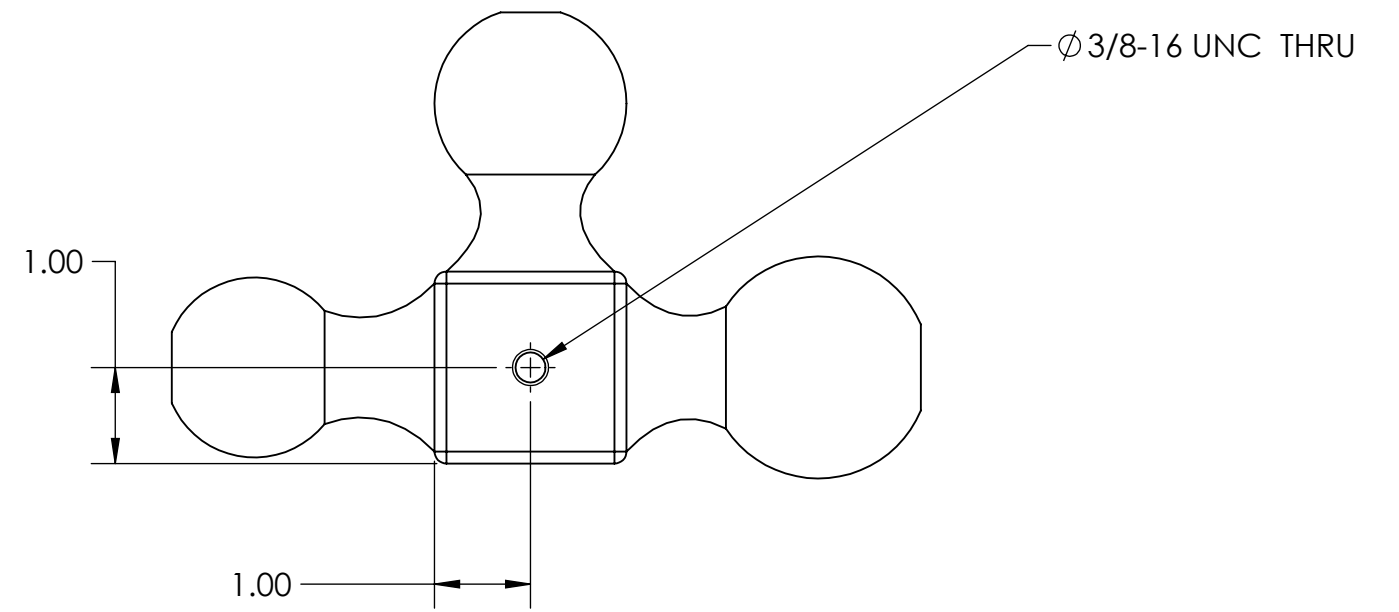
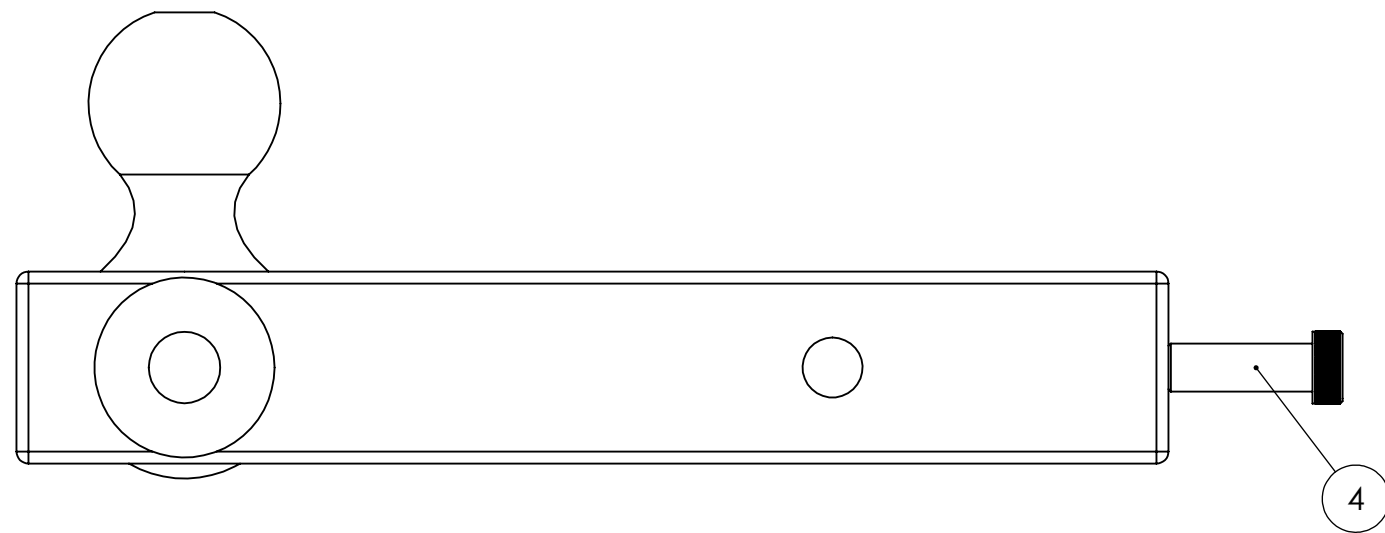


SCALE 1:2

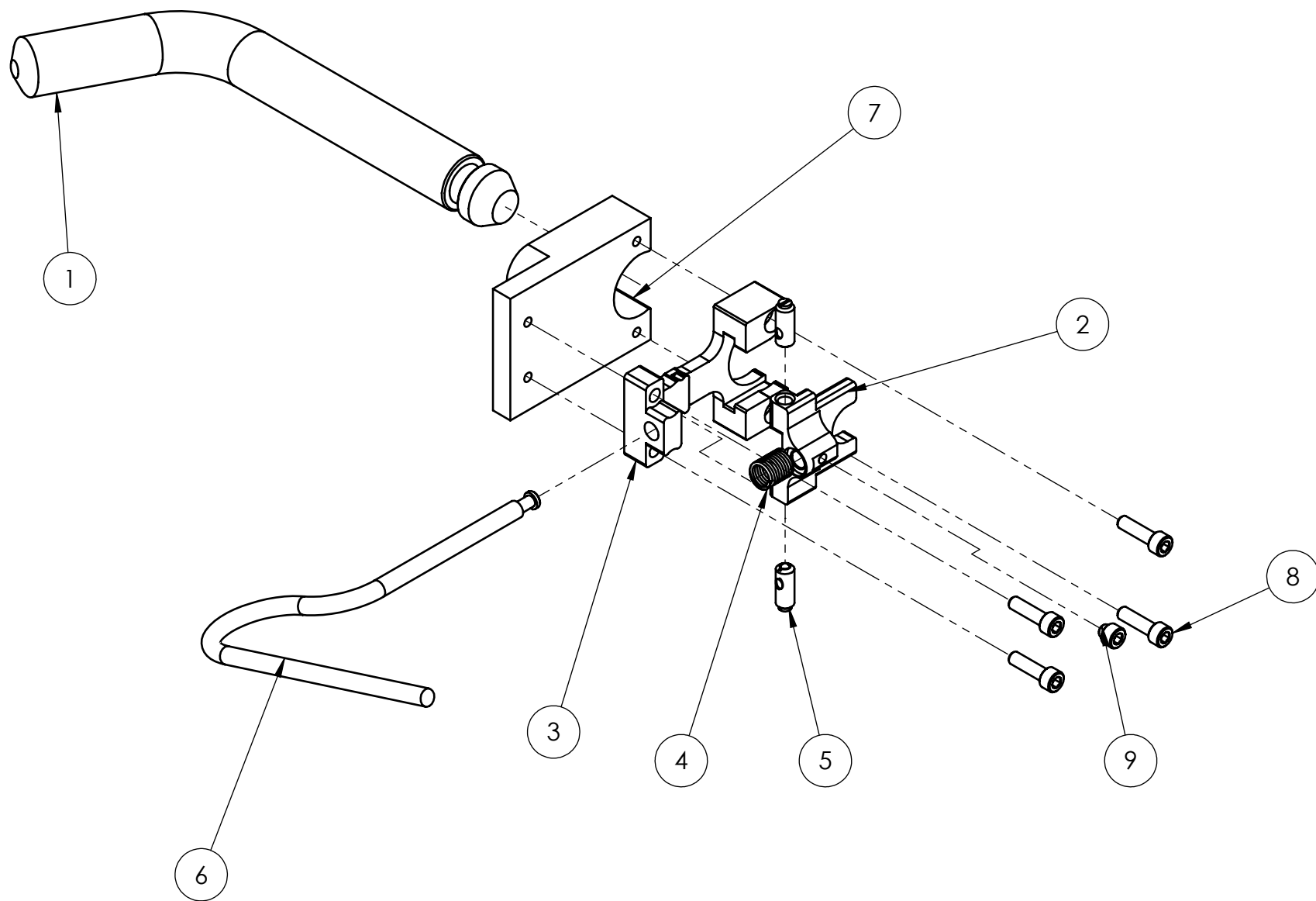


Cal Poly Mechanical Engineering ME 429 - WINTER 2019	Lab Section: 06 Dwg. #:TH3002	MATL: MILD STEEL Nxt Asb:TH2000	Title: ROTATING HITCH ASSEMBLY Date: 02/01/2019	Scale: 1:1	Drwn. By: ERIC RINGSRUD Chkd. By: MAX SELNA
---	----------------------------------	------------------------------------	--	------------	--

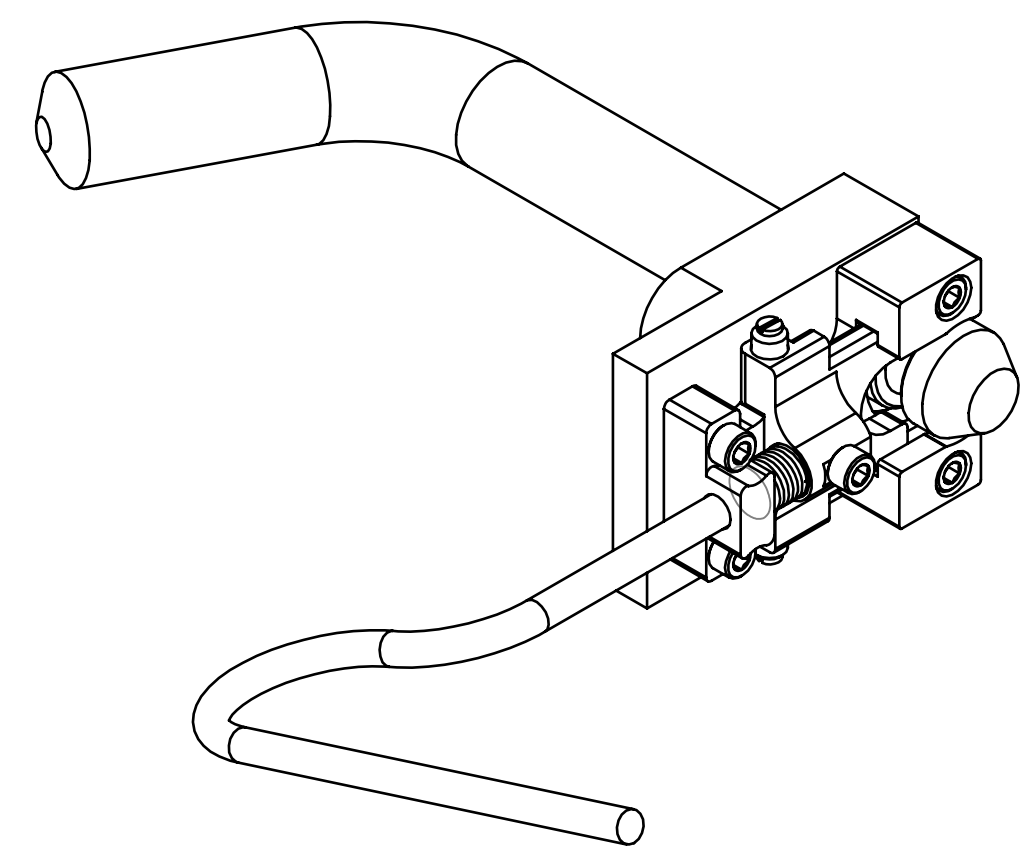
MODIFICATIONS TO HAUL MASTER TRIPLE BALL HITCH



Cal Poly Mechanical Engineering ME 429 - WINTER 2019	Lab Section: 06 Dwg. #:61914	MATL: MILD STEEL Nxt Asb:TH2000	Title: ROTATING HITCH ASSEMBLY Date: 2/1/2019	Scale: 1:2	Drwn. By: ERIC RINGSRUD Chkd. By: MAX SELNA
---	---------------------------------	------------------------------------	--	------------	--

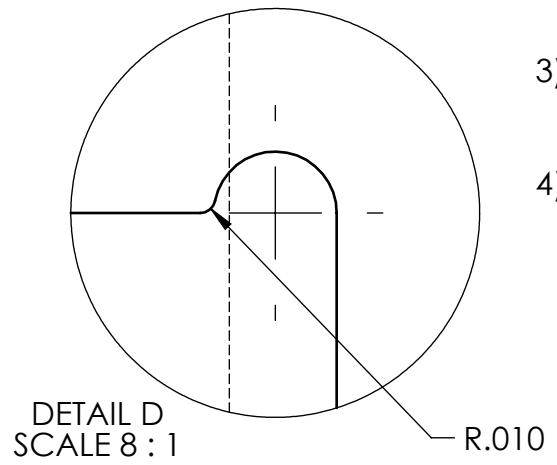
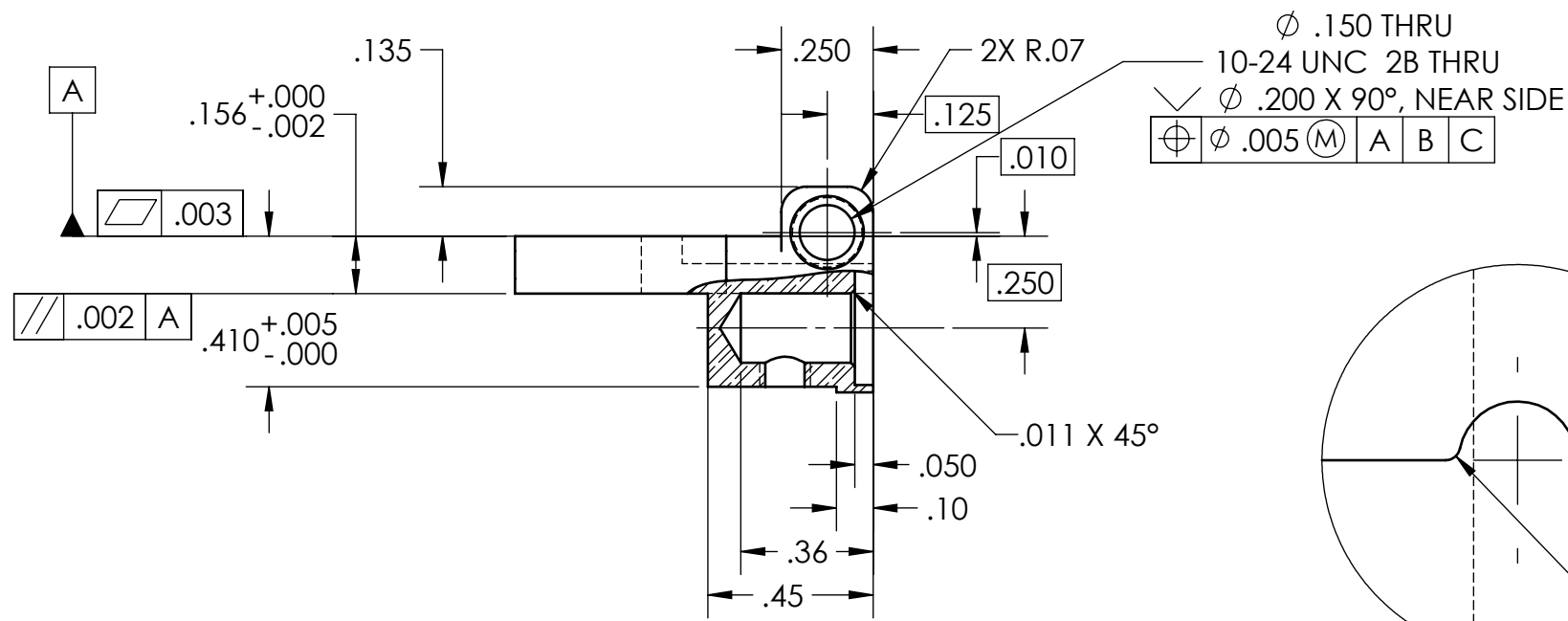


ITEM NO.	PART NUMBER	DESCRIPTION	QTY.
1	TOW READY 63240	GROOVED HITCH PIN	1
2	TH3011	NOTCH PLATE	1
3	TH3012	NOTCH PLATE CARRIER	1
4	McMaster Carr 9435K61	COMPRESSION SPRING	1
5	McMaster Carr 3408A523	BALL DETENT	2
6	TH3014	PULL HANDLE	1
7	TH3014	BASE PLATE	1
8	McMaster Carr 92196A148	#6-32 SHCS X 1/2"	4
9	McMaster Carr 92196A953	#6-32 SHCS X 3/32"	1



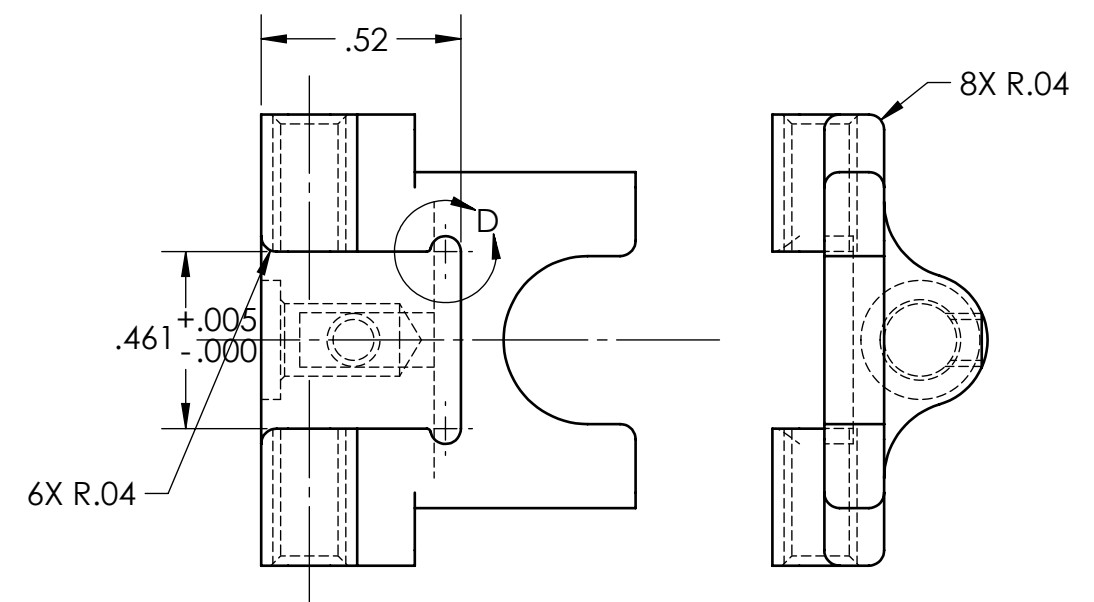
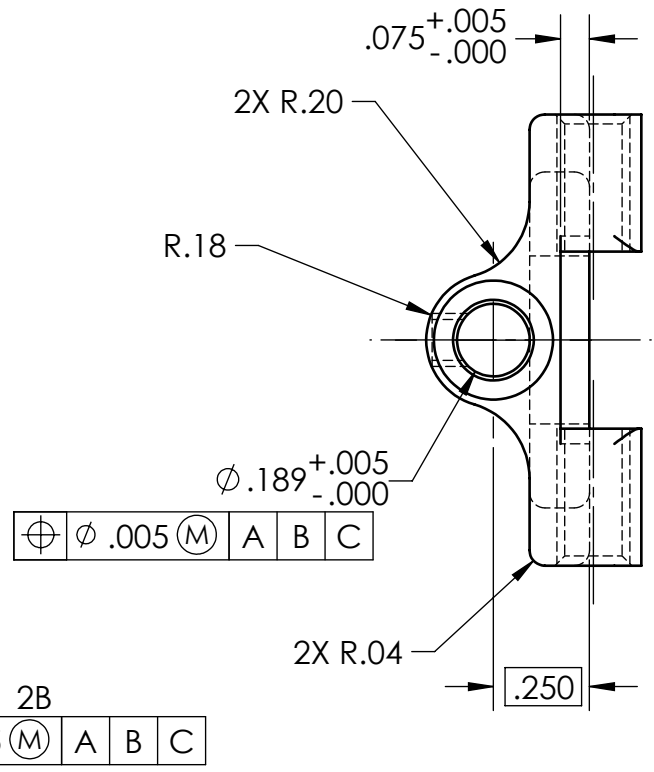
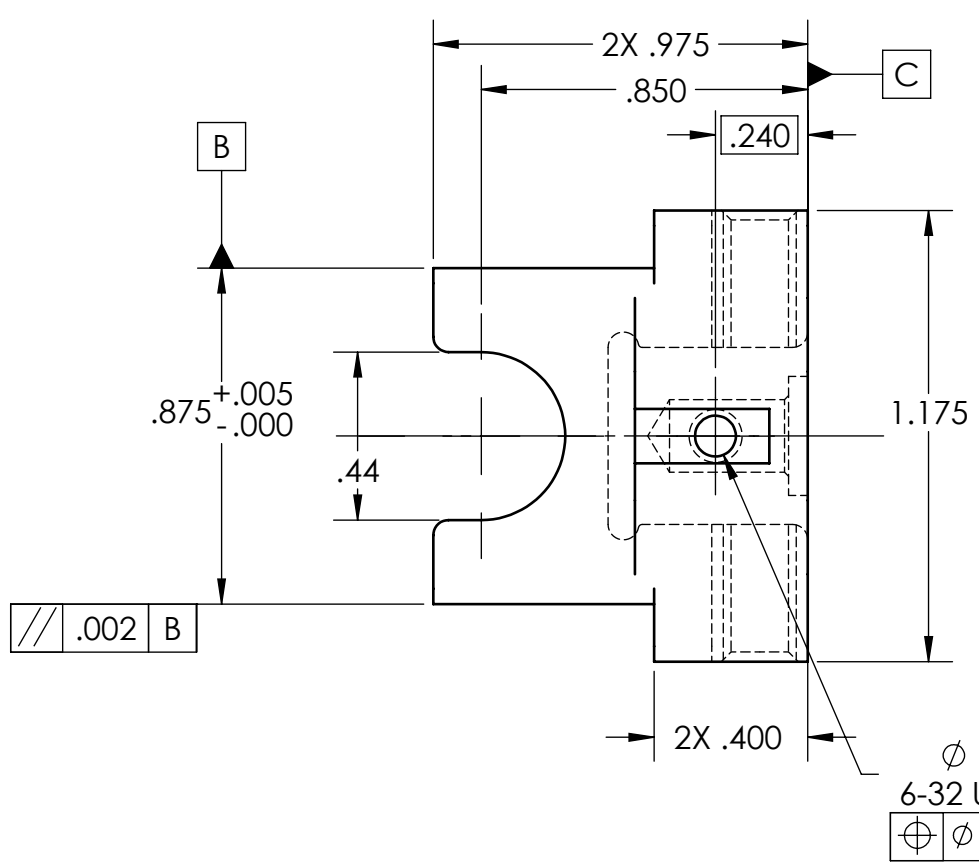
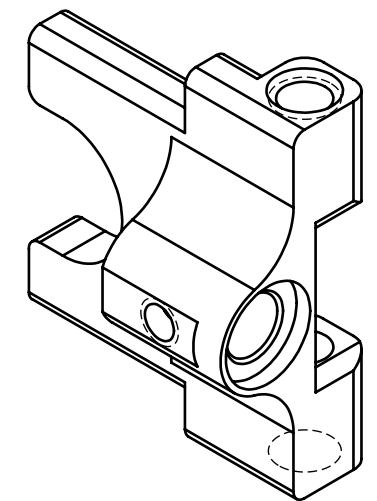
SCALE: 1=1

Cal Poly Mechanical Engineering ME 429 - WTR 2019	Lab Section: 06 Dwg. #: TH2010	MATL: VARIOUS Nxt Asb: TH1000	Title: PIN RETAINER SYSTEM Date: 01/29/2019	Scale: 2=3	Drwn. By: M. SELNA (64 HITCH) Chkd. By: ERIC RINGSRUD
--	-----------------------------------	----------------------------------	--	------------	--

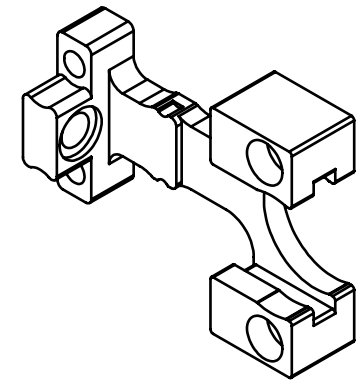


NOTES:
UNLESS OTHERWISE SPECIFIED:

- 1) DIMENSIONS IN INCHES
- 2) TOLERANCES:
 - X.XX ± .01
 - X.XXX ± .005
 - ANGLES ± .2°
- 3) BREAK ALL SHARP EDGES .005 MAX
- 4) 63 $\sqrt{\text{FAO}}$



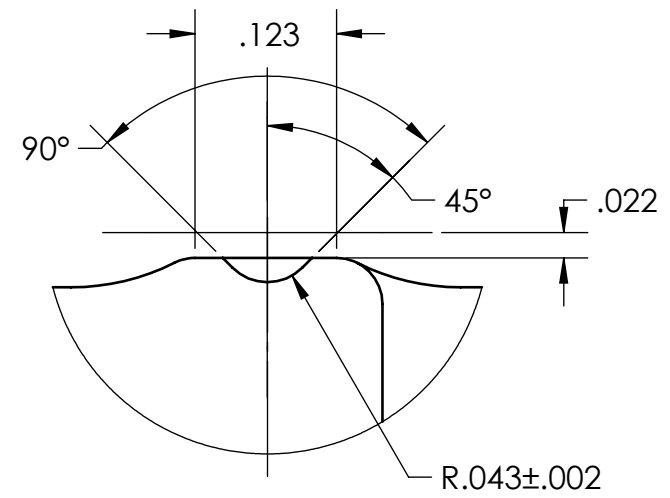
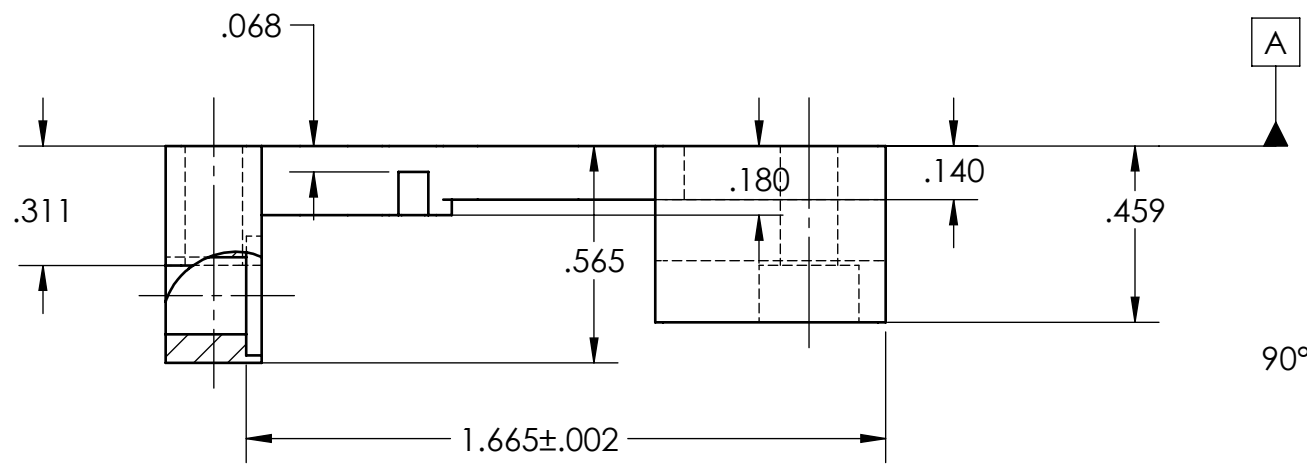
Cal Poly Mechanical Engineering ME 429 - WTR 2019	Lab Section: 06	MATL: SST 303	Title: NOTCH PLATE		Drwn. By: M. SELNA (64 HITCH)
	Dwg. #: TH3011	Nxt Asb: TH2010	Date: 1/29/19	Scale: 2=1	Chkd. By: ERIC RINGSRUD



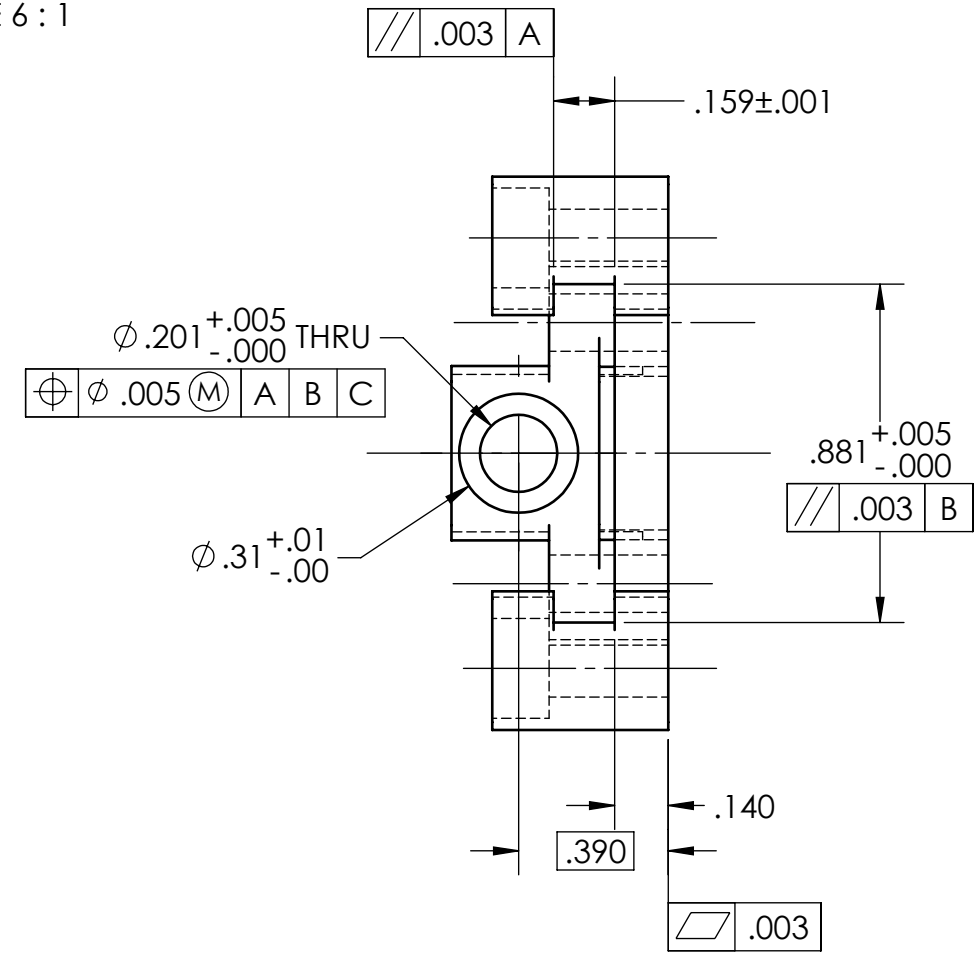
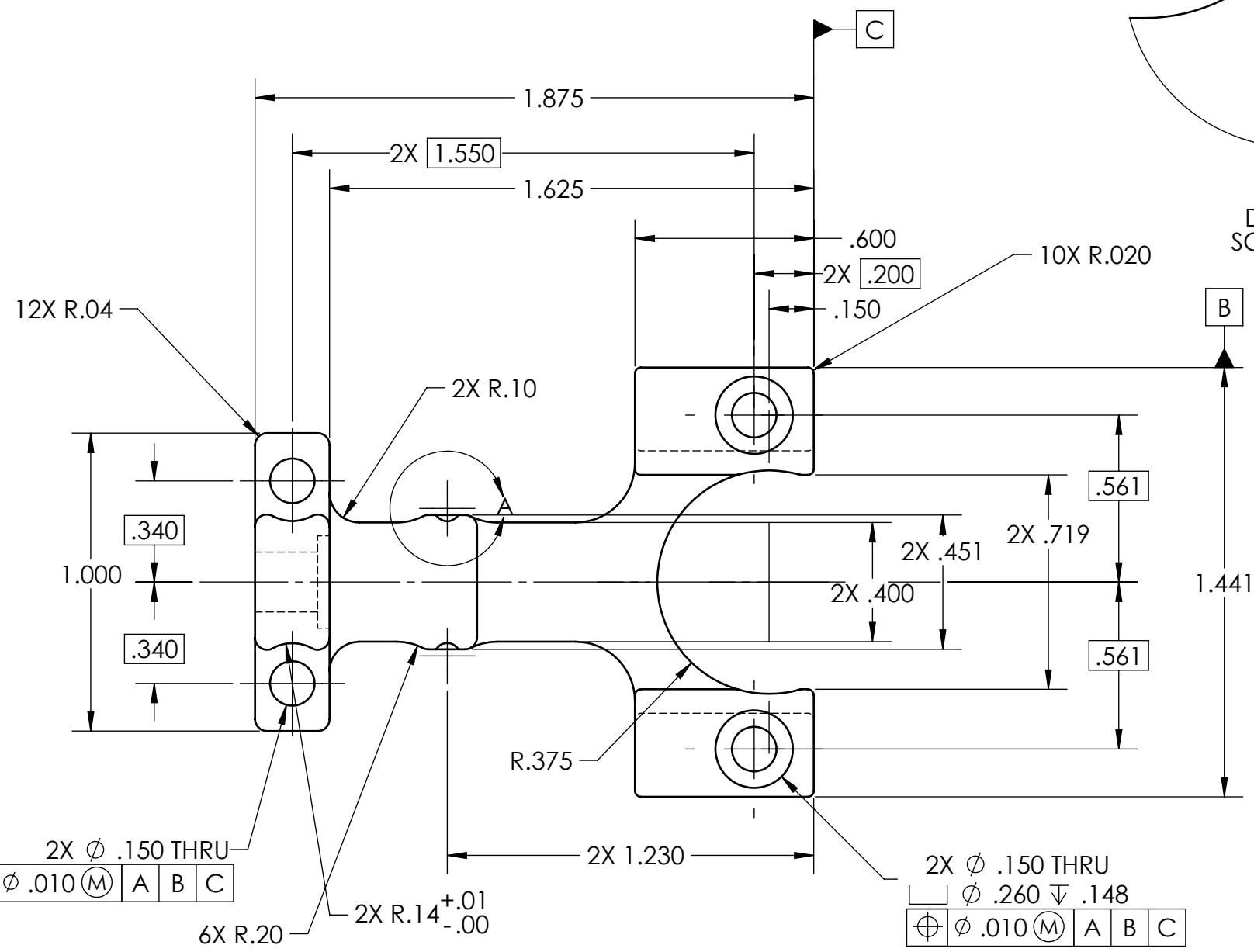
SCALE: 1=1

NOTES:
UNLESS OTHERWISE SPECIFIED:

- 1) DIMENSIONS IN INCHES
- 2) TOLERANCES:
 - X.XX±.01
 - X.XXX±.005
 - ANGLES ±.2°
- 3) BREAK ALL SHARP EDGES .005 MAX
- 4) 63 $\sqrt{\text{FAO}}$



DETAIL A
SCALE 6:1

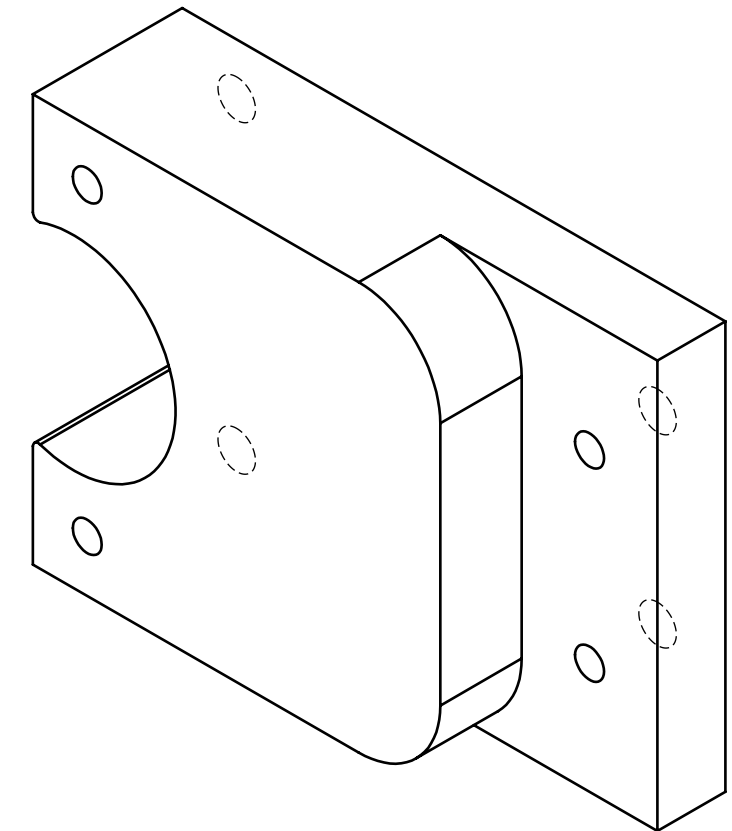
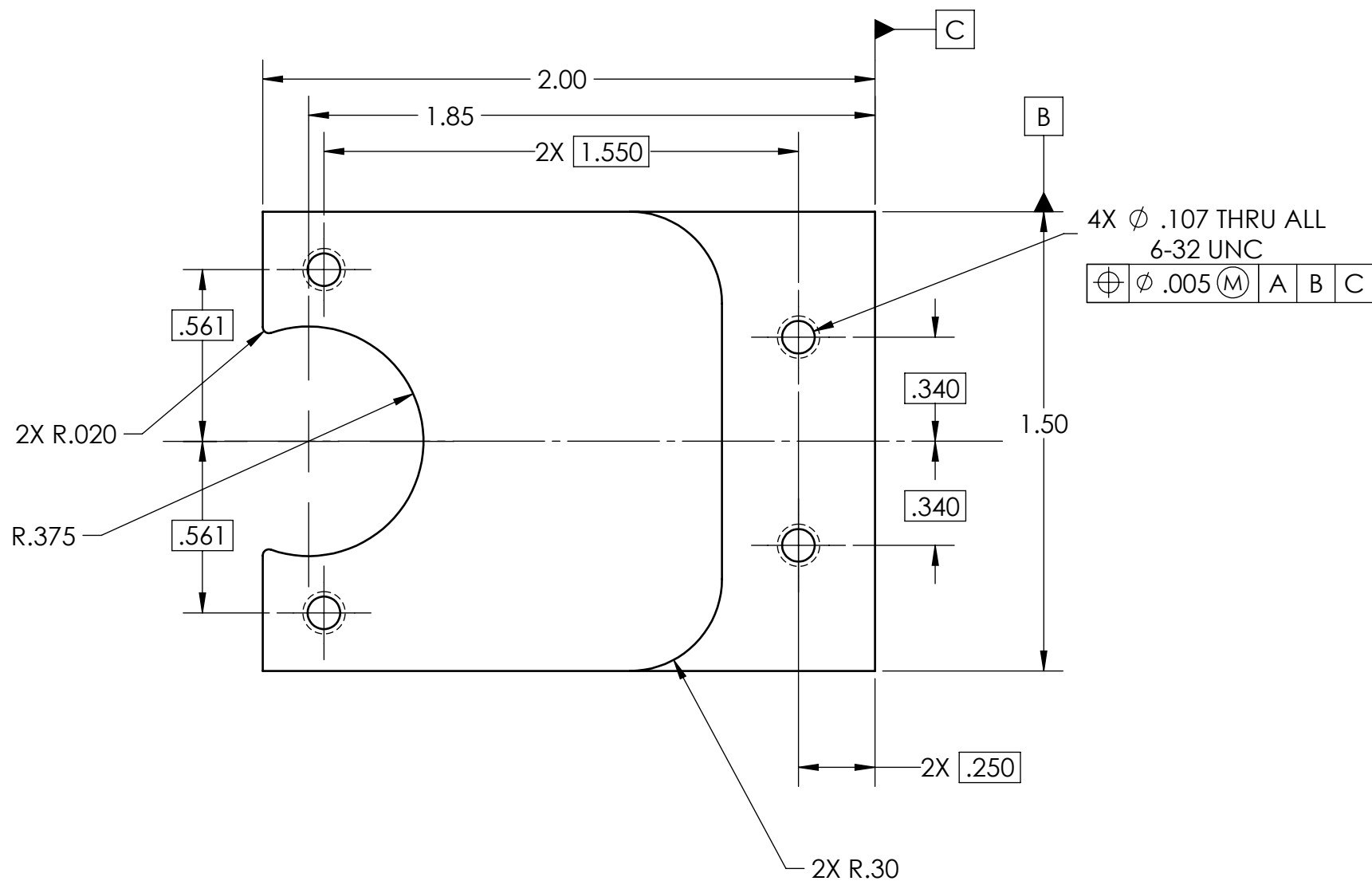
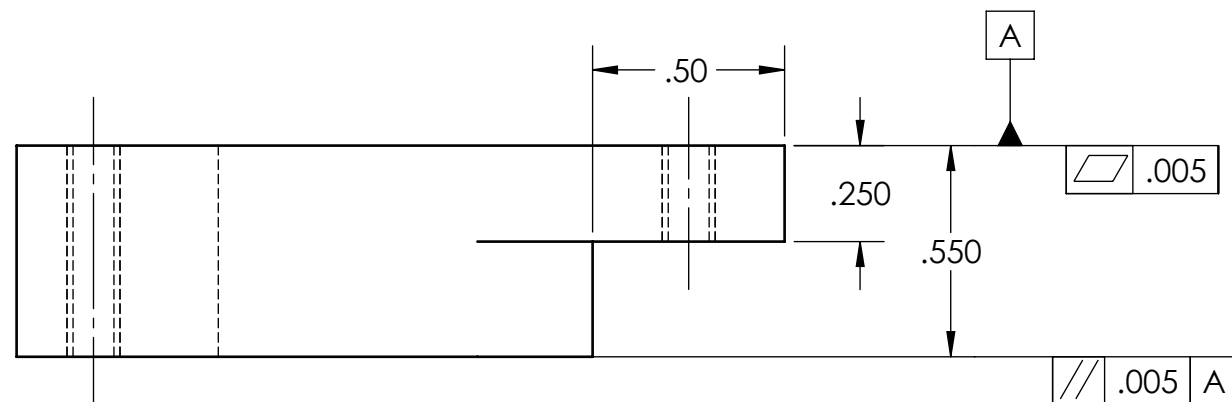


2X ϕ .150 THRU
 $\oplus \phi$.010 (M) A B C

2X ϕ .150 THRU
 $\oplus \phi$.260 ∇ .148
 $\oplus \phi$.010 (M) A B C

ϕ .201^{+.005}/_{-.000} THRU
 $\oplus \phi$.005 (M) A B C

Cal Poly Mechanical Engineering ME 429 - WTR 2019	Lab Section: 06	MATL: SST 303	Title: NOTCH PLATE CARRIER	Drwn. By: M. SELNA (64 HITCH)
	Dwg. #: TH3012	Nxt Asb: TH2010	Date: 01/30/2019 Scale: 2=1	Chkd. By: ERIC RINGSRUD



NOTES:
UNLESS OTHERWISE SPECIFIED:

- 1) DIMENSIONS IN INCHES
- 2) TOLERANCES:
 - X.XX ±.01
 - X.XXX ±.005
 - ANGLES ±.2°
- 3) BREAK ALL SHARP EDGES .005 MAX

4) 63 $\sqrt{\text{FAO}}$

NOTES:
UNLESS OTHERWISE SPECIFIED:

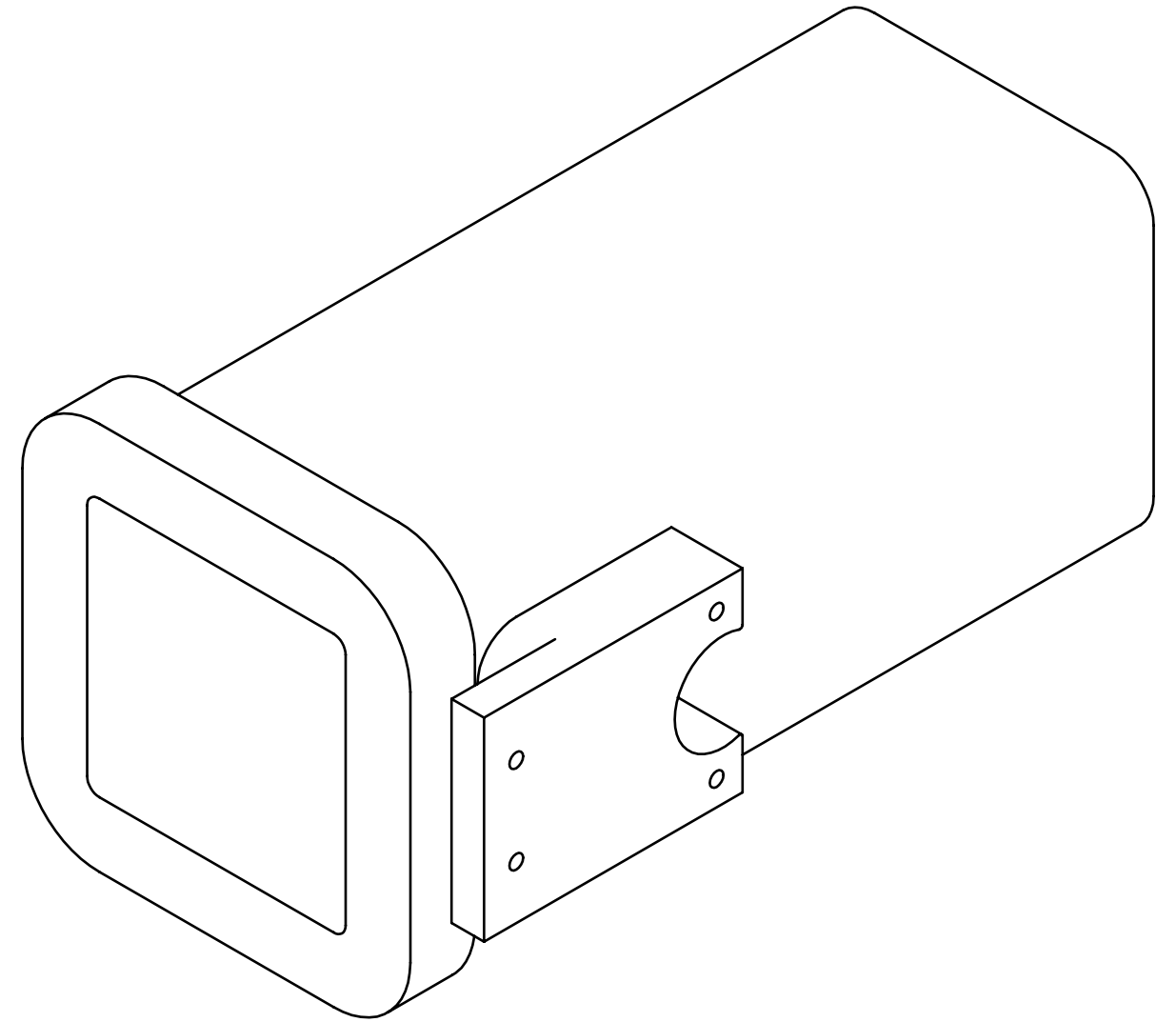
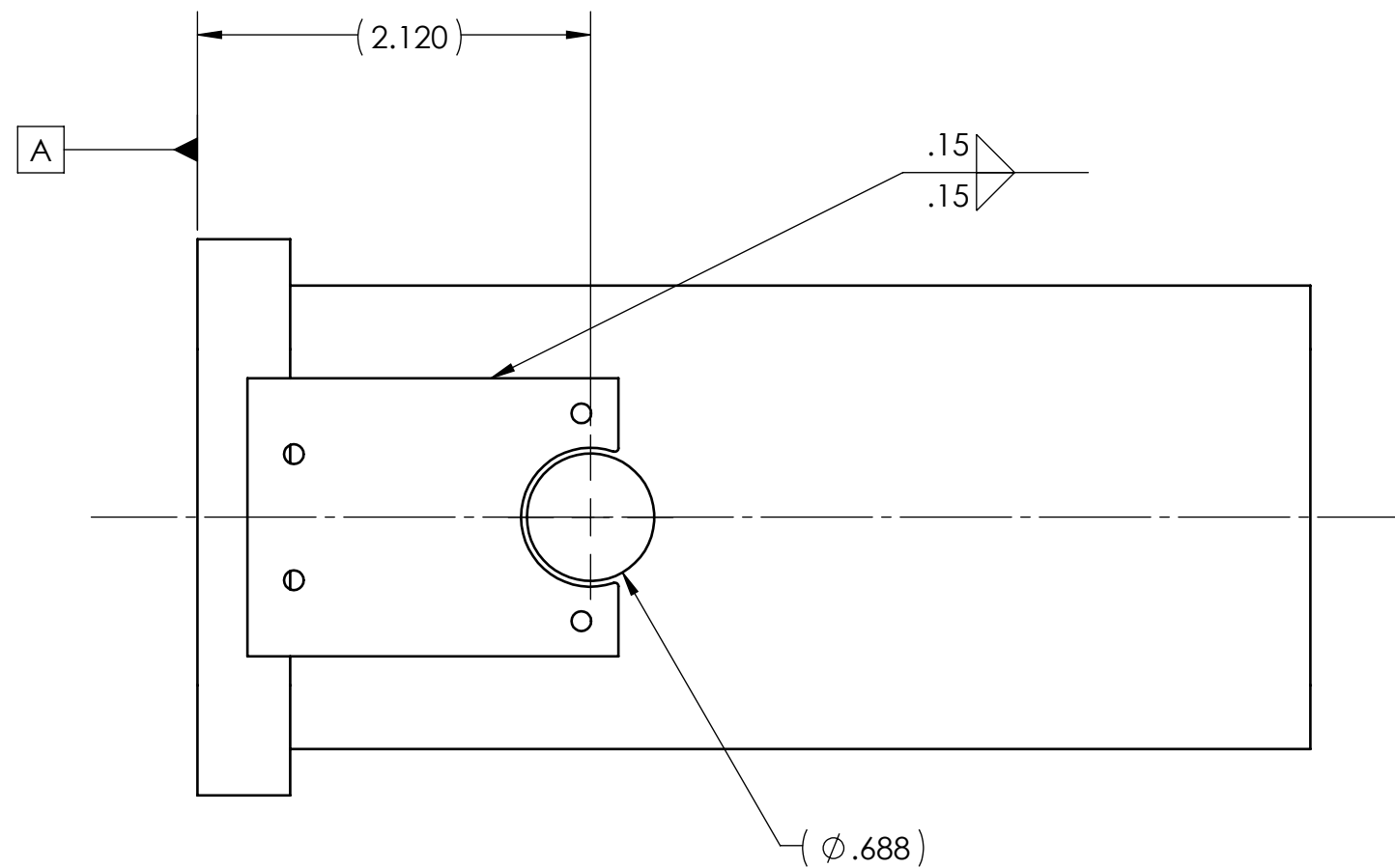
1) DIMENSIONS IN INCHES

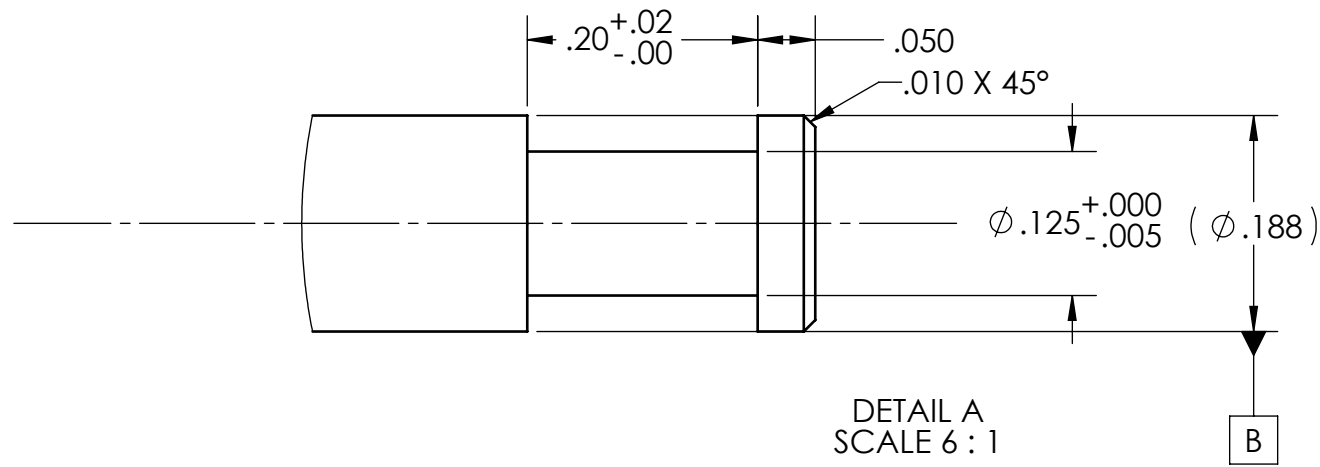
2) TOLERANCES:

- X.XX±.01
- X.XXX±.005
- ANGLES ±.2°

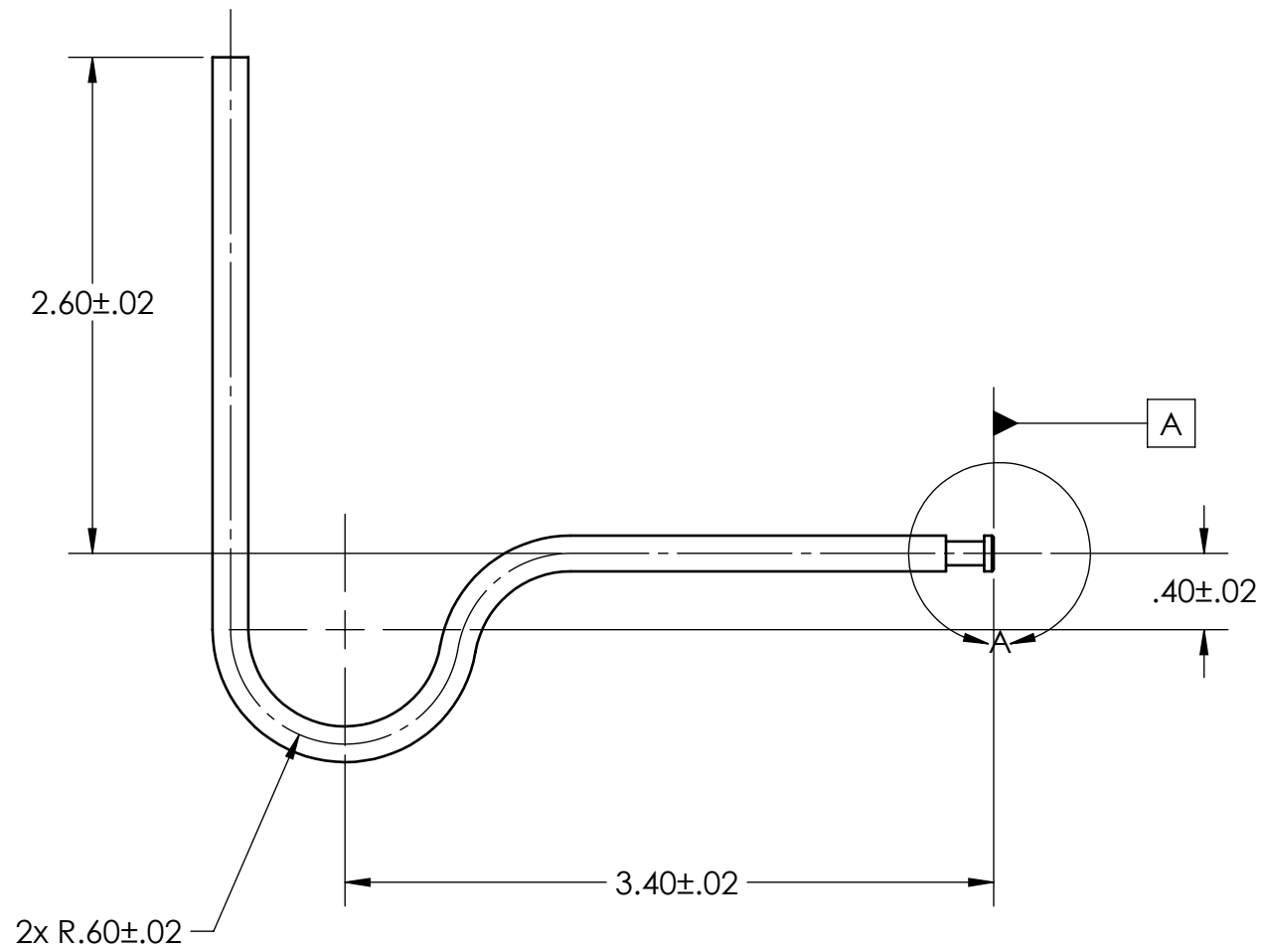
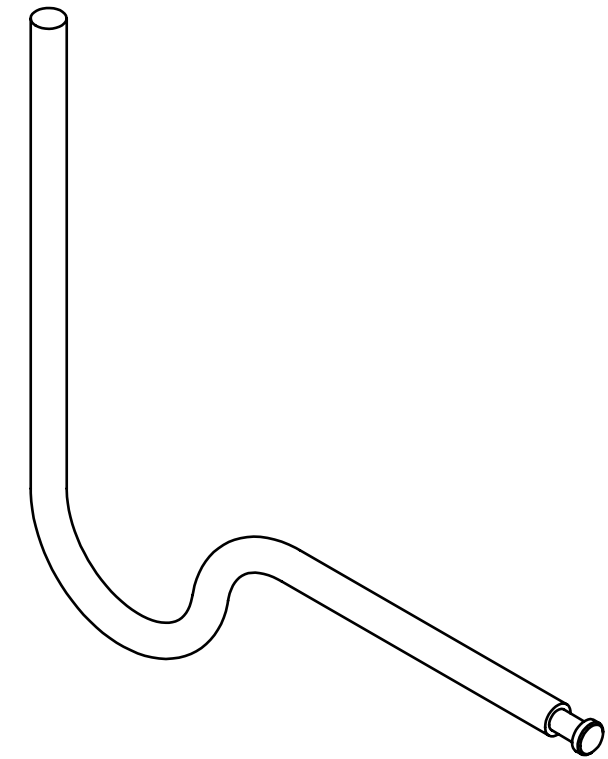
3) BREAK ALL SHARP EDGES .005 MAX

4) $63 \sqrt{\text{FAO}}$





USE NOMINALLY SIZED 3/16" ROUND BAR



TOTAL CUT LENGTH: 7.84

NOTES:
UNLESS OTHERWISE SPECIFIED:

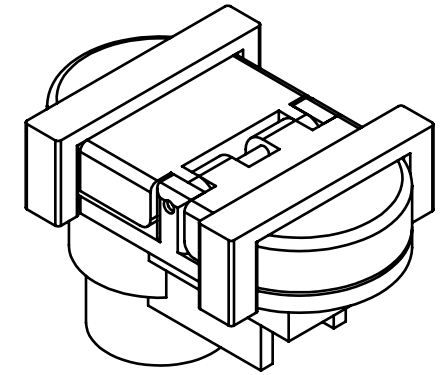
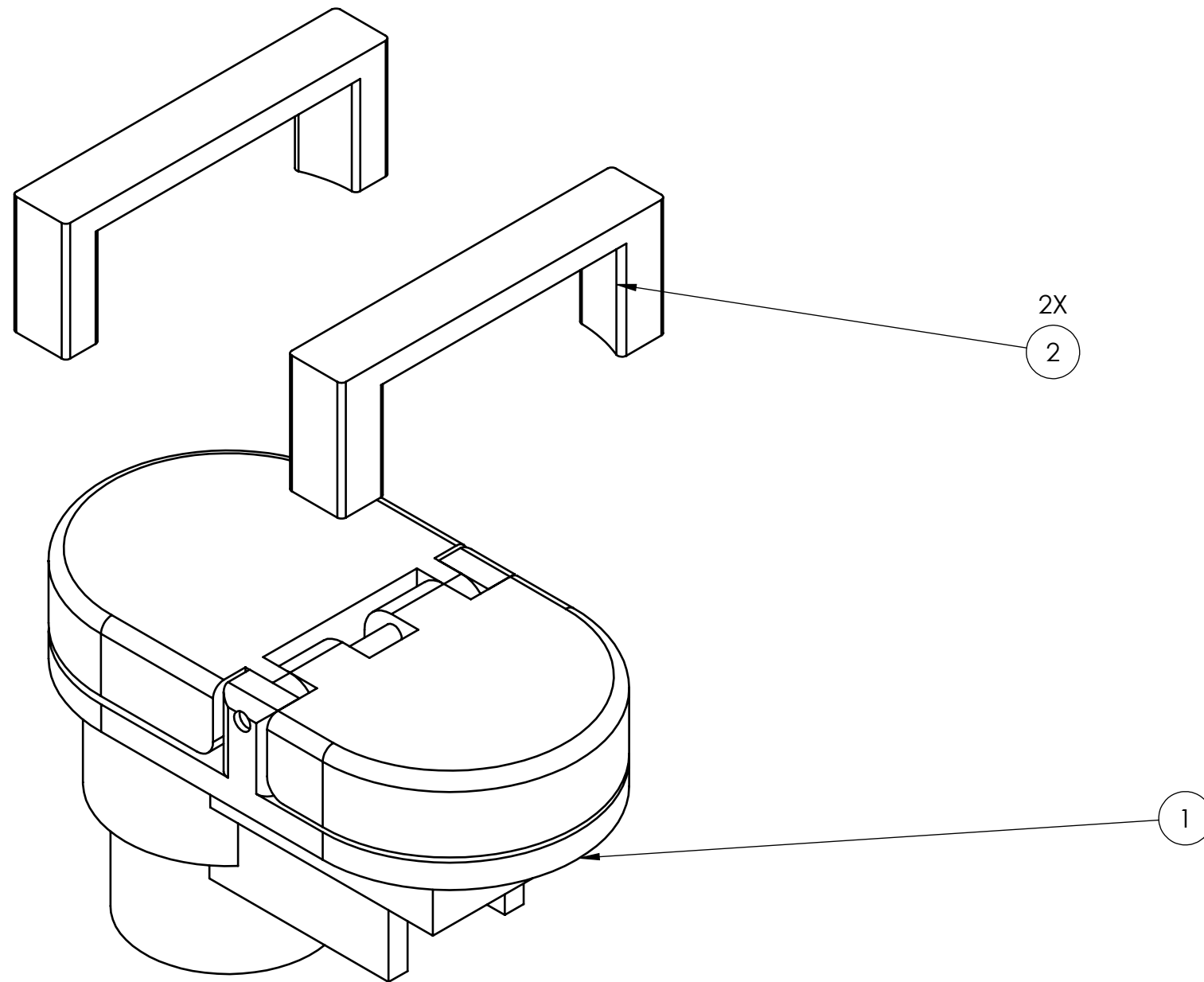
1) DIMENSIONS IN INCHES

2) TOLERANCES:

- $X.XX \pm .01$
- $X.XXX \pm .005$
- ANGLES $\pm .2^\circ$

3) BREAK ALL SHARP EDGES .005 MAX

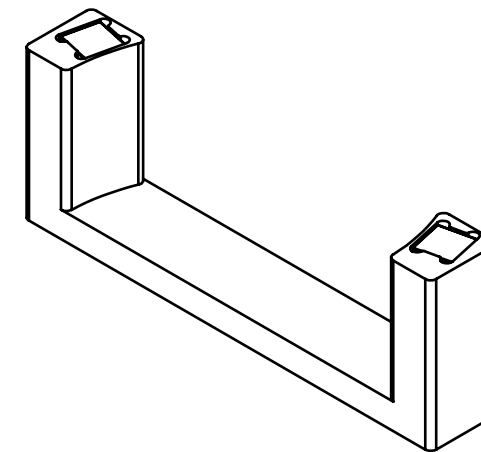
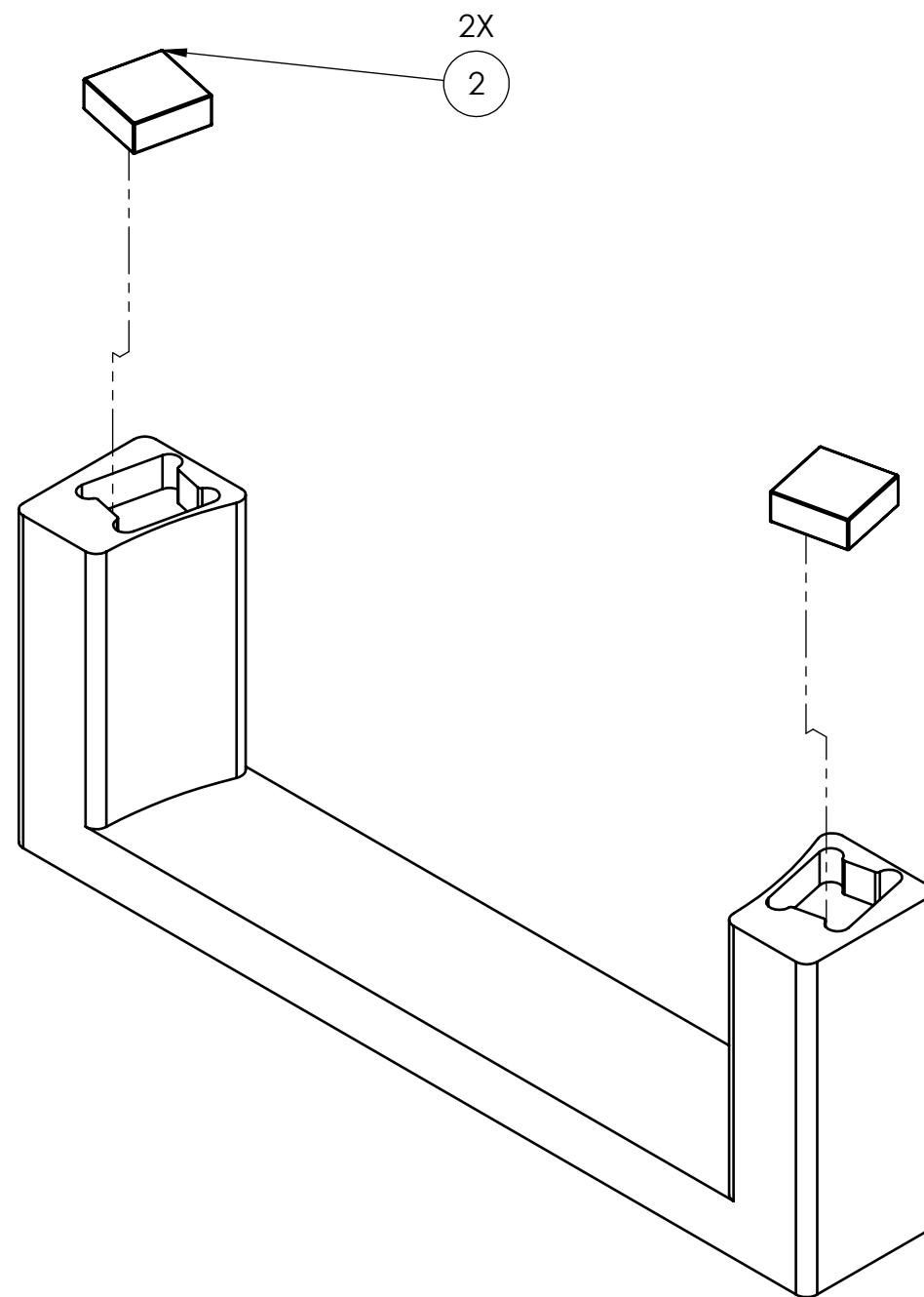
4) $63 \sqrt{\text{FAO}}$



SCALE 1:2

2	TH 2020	RECEPTACLE CAGE ASSEMBLY	2
1	56055632AC-M	ELECTRICAL RECEPTACLE ASSEMBLY	1
ITEM NO.	PART NUMBER	DESCRIPTION	QTY.

Cal Poly Mechanical Engineering ME 429 - WINTER 2019	Lab Section: 06	MATL: VARIOUS	Title: ER WITH CAGE	Drwn. By: MAX COSSALTER
	Dwg. #: TH2020	Nxt Asb: TH1000	Date: 02/02/2019 Scale: 1:1	Chkd. By: ERIC RINGSRUD



SCALE 1:1

2	7048T24	LOCK MAGNET	2
1	TH3022	CAGE	1
ITEM NO.	PART NUMBER	DESCRIPTION	QTY.

Cal Poly Mechanical Engineering ME 429 - WINTER 2019	Lab Section: 06	MATL: VARIOUS	Title: RECEPTACLE CAGE ASSY	Drwn. By: MAX COSSALTER
	Dwg. #:TH3021	Nxt Asb: TH2020	Date: 02/02/2019	Scale:2:1
				Chkd. By: ERIC RINGSRUD

NOTES:
UNLESS OTHERWISE SPECIFIED"

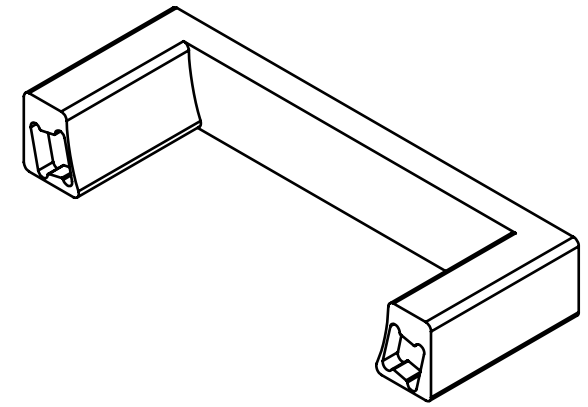
1) DIMENSIONS IN INCHES

2) TOLERANCES

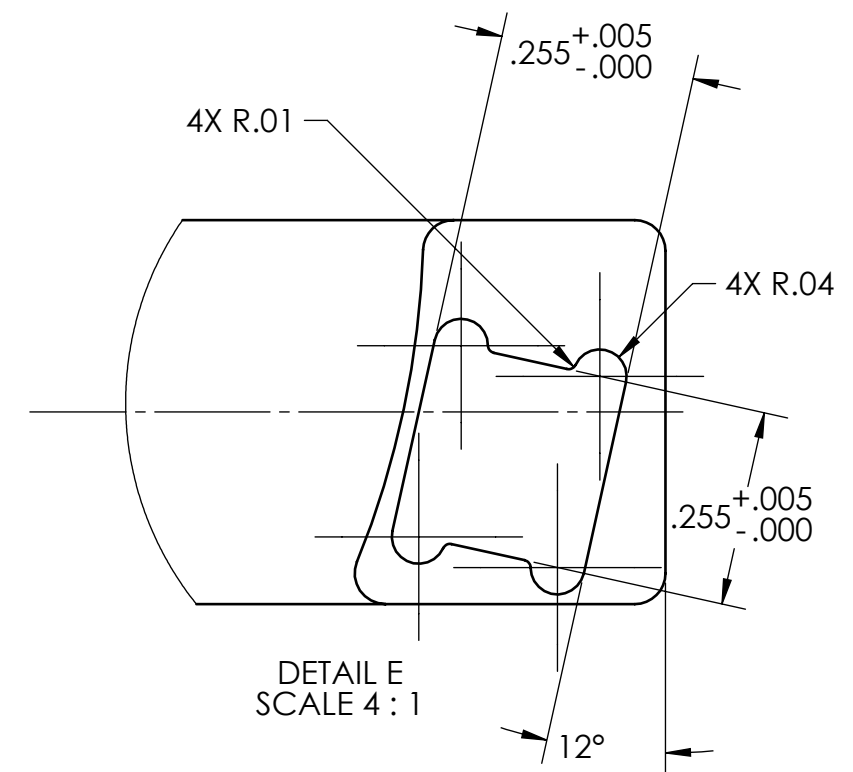
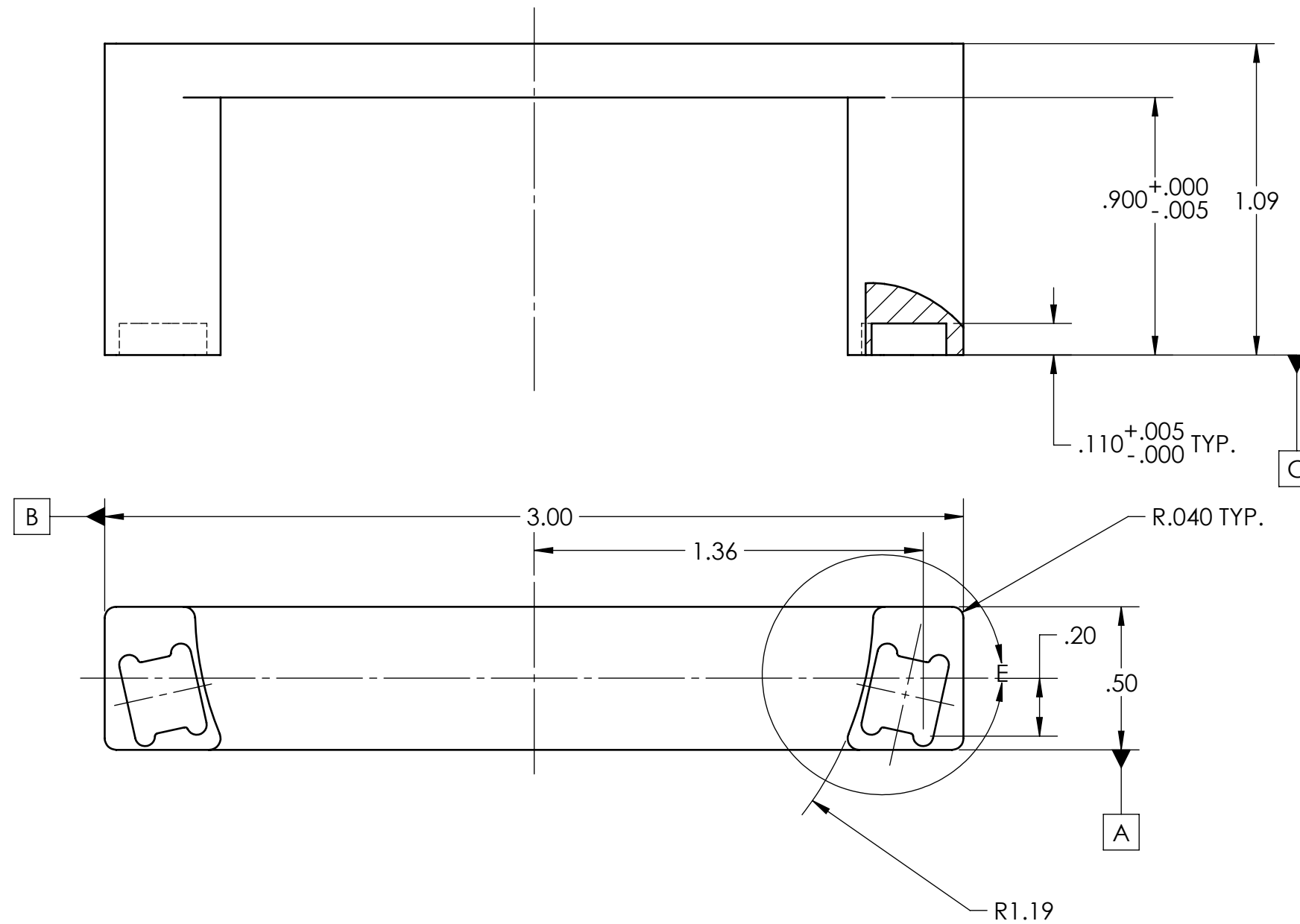
- X.XX=±.01
- X.XXX=±.05
- ANGLES±.2°

3) BREAK ALL SHARP EDGS .005 MAX

4) $63\sqrt{\text{FAO}}$



SCALE 1:1



Cal Poly Mechanical Engineering
ME 429 - WINTER 2019

Lab Section: 06
Dwg. #:TH3022

MATL: 6061 T6
Nxt Asb: TH3021

Title: RECEPTACLE CAGE ASSY
Date: 02/02/2019

Scale:2:1

Drwn. By: MAX COSSALTER
Chkd. By: ERIC RINGSRUD