

Gravity Drip Irrigation System

Final Design Review

Presented By

Cole Presson

Ryan Waldron

Josh Plaskett

gravitydripcp@gmail.com

Mechanical Engineering Department
California Polytechnic State University

San Luis Obispo

Spring 2019

Prepared For

Tina Creel

Statement of Disclaimer

Since this project is a result of a class assignment, it has been graded and accepted as fulfillment of the course requirements. Acceptance does not imply technical accuracy or reliability. Any use of information in this report is done at the risk of the user. These risks may include catastrophic failure of the device or infringement of patent or copyright laws. California Polytechnic State University at San Luis Obispo and its staff cannot be held liable for any use or misuse of the project.

Abstract

A gravity-fed, drip irrigation system prototype has been developed for use in raised garden beds and other small-scale crop irrigation applications. The original developer of the prototype and sponsor of the project, Tina Creel, is seeking to refine it into a functional consumer product through the implementation of technical engineering and standard manufacturing processes. The scope of the project includes the tank support system and supply of water to the sponsors current piping subsystem. It does not include any modifications to the bed, piping system or water tank itself. The target specifications of the system include its load capacity, dimensions, susceptibility to leakage, durability, and assembly time. Numerous potential design concepts were ideated and compared so that a design direction could be established. This document serves as a complete outline of the project and includes the initial design/research proceedings, concept design process, explanation of the chosen design, and the manufacturing process as well as the testing results for the prototype design.

Table of Contents

1	Introduction	1
2	Background	1
2.1	Customer/Need Research	1
2.2	Product Research.....	3
2.3	Technical Research.....	4
2.3.1	Pressure	5
2.3.2	Emitters	6
2.3.3	Frictional Losses	7
3	Objectives	7
3.1	Design Considerations	8
3.2	Quality Function Deployment	9
3.3	Engineering Specifications	9
4	Concept Design	11
4.1	Concept Design Process.....	11
4.1.1	Top Concepts	12
4.2	Chosen Concept	14
4.3	Concept Risks and Challenges	15
5	Final Design.....	15
5.1	Design Description.....	15
5.2	Design Justification	21
5.3	Safety	21
5.4	Maintenance and Repair.....	22
5.5	Failure Modes and Effects Analysis.....	22
5.6	Cost Summary	23
6	Manufacturing	24
6.1	Material Procurement.....	24
6.2	Manufacture.....	24
6.3	Assembly	31
7	Design Verification	32
7.1	Specifications and Tests	32
7.2	Test Results.....	35
8	Project Management.....	35
9	Conclusion	36
	Works Cited.....	38
	Appendix A - QFD Table	40
	Appendix B – Preliminary Analysis	41

Appendix C – Design Hazards Checklist.....	44
Appendix D – FMEA.....	46
Appendix E – Expanded Bill of Materials.....	47
Appendix F – Links to Sourced Product Literature	48
Appendix G – Drawing Package	1
Appendix H – Test Plans.....	1
Appendix I - Design Verification and Report.....	7
Appendix J - Gantt Chart.....	8
Appendix K - Operators Manual	9

List of Figures

Figure 1. Current Prototype System; Developed by Tina Creel.....	2
Figure 2. Diagram of the basic functionality of a swale. [6] Manufactured variations of swales exist for water collection and could potentially be employed in the Gravity Drip System for stormwater collection as is done in the patent for ‘ <i>Elevated Swale...</i> ’ [7].....	3
Figure 3. Automated sprinkler control panel, requiring power for operation as well as significant head. User input is needed for the device to operate properly. [8].....	4
Figure 4. Example of battery powered watering timer product. [9].....	4
Figure 5. Relationship between water level and pressure. [12].....	5
Figure 6. Test of uniformity of a drip irrigation system operating at under 2 psi. [13].....	5
Figure 7. Example of various drip emitter styles. [16]	6
Figure 8. Graph depicting the operating pressure of the current prototype system. [17]	7
Figure 9. Boundary Diagram Sketch. Design considerations include the support system for the tank and the front facing manifold to which hoses are connected.....	8
Figure 10. Box Stand Concept	12
Figure 11. Telescoping legs concept design.....	13
Figure 12. Telescoping arms concept design.	13
Figure 13. Front-Facing Manifold Concept	14
Figure 14. Full compact assembly of frame and piping connections.....	16
Figure 15. Exploded view of welded support frame and telescoping arms.....	17
Figure 16. Telescoping arm and locking mechanism.....	17
Figure 17. Piping Sub-system assembly, compact (left) and exploded view (right).....	18
Figure 18. Example of a pneumatic manifold made of anodized aluminum.	19
Figure 19. Manifold prototype, constructed of thick wall steel tubing with capped ends.....	19
Figure 20. Manifold faceplate with drilled holes for hose adapters and flathead bolts.....	20
Figure 21. Garden Hose Thread to Pipe Thread adapter which pulls the faceplate flush against the manifold when fully threaded.....	20
Figure 22. Abbreviated BOM.....	24
Figure 23. Cutting of system cross frame and legs to their appropriate lengths.....	25
Figure 24. Tacked cross frame.....	26
Figure 25. Cross frame with welded leg supports.....	27
Figure 26. Frame with welded leg brackets.....	27

Figure 27. Welding Frame Base.....	28
Figure 28. Welded base frame with telescoping arms inserted.....	29
Figure 29. Manifold with located and tacked weld bungs.....	30
Figure 30. Fully welded frame assembly.....	31
Figure 31. Water loaded barrel with attached load scale.....	33
Figure 32. Preparing digital calipers to measure frame displacement under load.....	34

List of Tables

Table 1. System Specifications and Target Values.....	10
Table 2. Simplified Bill of Materials.....	23
Table 3. Summary of Test Results.....	35
Table 4. Project Deliverables and Key Deadlines.....	36

1 Introduction

We are a group of three mechanical engineering students, Cole Presson, Ryan Waldron, and Josh Plaskett, from California Polytechnic State University San Luis Obispo. The Gravity Drip Irrigation system outlined in the following pages is being completed as our senior design project. Our sponsor, Tina Creel, has tasked us to design and manufacture this irrigation system for her personal use in her home garden, and as a marketable product that can be sold to others in need of a more efficient system. The end goal of the design process was to present the sponsor with a polished, marketable, and innovative Drip Irrigation System that she can take to market. The timeline for the design spanned the entire 2018-19 academic year. The project began in late September and concluded on May 31st with a project expo. This report will include background research of our product, outline our objectives, describe how we established a design direction, and walk through the process by which we manufactured and tested our chosen design. This document builds on the Critical Design Review document; sections 6 and 7 include new content regarding manufacturing and test review and other sections have been revised to reflect the project's completion.

2 Background

Our initial research began with researching three aspects of the product, the customer/need research, existing product research, and technical research. Customer/need research consisted of a meeting with the sponsor in order to determine the wants and needs of the final product and general research into the overall problem that the product is meant to solve. The product research focused on benchmarking similar products and other solutions to the problem. Finally, the technical research focused on the applicable technology that will be used in order to complete the project.

2.1 Customer/Need Research

Agriculture encompasses 70% of the world's fresh water usage. Since it is limited resource, it is important to ensure water is used as efficiently as possible throughout the irrigation process. Drip irrigation is an alternate option to traditional flood irrigation techniques that is much more efficient and even results in a greater yield. A study conducted in Umakot, Pakistan showed that drip irrigation saved 56.4% more water and resulted in a 22% greater yield when compared to furrow irrigation [1]. This greater efficiency is achieved through targeting the roots specifically rather than soaking the leaves and stems and leaving them prone to rot [2]. Although passive drip irrigation is extremely efficient and cost effective, it is not widely used. As part of our customer research we interviewed our sponsor in order to determine the vision she has for turning this irrigation method into a marketable product. Our sponsor specified the following goals for the final product:

- Can be operated with minimum input from the user
- Can reliably provide flow throughout irrigation process
- Can hold up to 10 gallons of water
- System is quick to assemble/disassemble
- Easily repairable (replaceable parts)
- Targeted towards the irrigation of raised beds
- Modular/adjustable so to work for varying bed heights/dimensions
- Front facing manifold for easier line connections
- Durable – Cannot deteriorate from sun exposure
- Marketable as a Do-It-Yourself irrigation kit

Currently, the sponsor is using a self-made drip irrigation system. The system is functional, but needs to be refined so that it can be brought to market. The current system is pictured in Figure 1.



Figure 1. Current Prototype System; Developed by Tina Creel.

Many of the sponsor's goals are not met by this system. The manifold is located on the bottom of the container, making it difficult to set up [3]. The life cycle of these type of containers pose an issue for the system because they deteriorate after about a year due to weather damage. Standard drip irrigation emitters [4] are used to dispense water to each plant in the garden bed; these emitters are constructed of cheap plastic, are difficult to handle and are easily broken. The only means to adjust height is by placing the container on different stands. Finally, the overall system needs to be polished so it can be appealing to consumers.

2.2 Product Research

When conducting product research for this project, we set our focus on small-scale irrigation solutions that are currently on the market, while still considering components and subsystems that are utilized in large-scale irrigation systems. After conducting research, we determined that products in this market could be broken into three key watering system groups; passive, active and hybrid.

The first category, passive, includes systems that water plants/crops without the use of power or extensive input from the user. This category of systems encompasses landscape manipulation and rainwater collection as means of irrigation, examples include: Swales (Figure 2), Contour gardening, Check-Log Terracing [5], etc. Many of the ‘products’ in this category are Do-It-Yourself solutions to small-scale irrigation and don’t fully satisfy watering needs due to their reliance on rainwater collection.



Figure 2. Diagram of the basic functionality of a swale. [6] Manufactured variations of swales exist for water collection and could potentially be employed in the Gravity Drip System for stormwater collection as is done in the patent for ‘*Elevated Swale...*’ [7].

The second, and most common, type of system used for small-scale irrigation is active. This category of irrigation solution includes systems that meet at least one of the following criteria:

- Requires connection to large-scale power supply, i.e. AC plugin
- Requires significant user interaction to function properly

Based on these criteria established during the research process, systems such as sprinklers, drip irrigation and most irrigation flow controllers are included in the active category. The vast



majority of systems that are currently on the market fall into this category and often hit both of the criteria listed above as demonstrated by the standard sprinkler control panel in Figure 3.

Figure 3. Automated sprinkler control panel, requiring power for operation as well as significant head. User input is needed for the device to operate properly. [8]

Category three, hybrid systems, is the target for the Gravity Drip System upon the completion of this project. This category of system blends the positive attributes of passive and active systems and incorporates them into a single comprehensive solution. Products that do not hit the criteria listed for active systems but still require some form of user or power input are what we consider to be hybrid solutions. The scope of this category is limited to very few products. Currently, the only solutions that we considered to be hybrid battery powered watering timers that require minimal setup from the user before watering passively (Figure 4), and the prototype for the Gravity Drip System.



Figure 4. Example of battery powered watering timer product. [9]

In order to supplement product research, a search of related patents was conducted. Due to the nature of the product, many components, such as emitters, piping [10], and valves will be sourced. The patents for these components are listed in works cited. While the system will utilize these sourced components, the overall function of the design will be unique. The sponsor's current prototype, is very similar to the drip irrigation system under US Patent 7048010B2 [11]. This patent specifies a distribution pipe with numerous distribution lines branching off of it. Each smaller distribution line is tipped with an emitter that applies water directly to the soil. This water delivery subsystem will most likely be implemented in our iteration of the product.

2.3 Technical Research

The technical research for this project can be broken down into three major topics. Water pressure is the main area for research as very low pressure systems are uncommon and drip irrigation systems have to be specifically designed to operate at low pressures. The second topic focuses on drip irrigation emitters. Lastly, frictional losses and the resulting pressure loss in the system and how they can be minimized to effectively use the limited head pressure available.

2.3.1 Pressure

Hydrostatic pressure or head pressure is defined as the pressure produced as a result of a difference in elevation between the water level in the water storage unit and the water outlet. Water pressure declines linearly as the height of the water level decreases with flow out of the tank. For a gravity fed drip irrigation this change in height is the source of the pressure for the entire system. The volume of water at an elevated height does not increase head pressure, only the total volume of water that can be supplied at that specific pressure.

Hydrostatic pressure in a liquid can be calculated as

$$p = \rho g h \quad (1)$$

where

p = pressure in liquid (N/m², Pa, lb_f/ft², psf)

ρ = density of liquid (kg/m³, slugs/ft³)

g = acceleration of gravity (9.81 m/s², 32.17405 ft/s²)

h = height of fluid column - or depth in the fluid where pressure is measured (m, ft)

Figure 5. Relationship between water level and pressure. [12]

An irrigation system that is specifically designed to operate at ultra-low water pressures in the 1-2 psi pressure range has been shown to be capable of supplying up to ¼ acres with uniform application of water [13]. Figure 6 depicts a test being conducted by the University of Kentucky to investigate how the low pressure water source affects emitter flow rate and uniformity of the flowrate at each emitter.



Figure 6. Test of uniformity of a drip irrigation system operating at under 2 psi. [13]

2.3.2 Emitters

Drip irrigation emitters use several different methods of decreasing pressure to reduce flow rate at the outlet. Flow rate data for many emitters does not go below 10 psi, shown in Figure 8, as they are intended to be used with higher pressure systems with a regulator that maintains a set pressure. Figure 7 shows just a few of the different style of emitters available. The NC, or non-compensating, Flag emitter is what is the sponsor's current prototype uses. This style emitter has the ability to be disassembled for cleaning. Clogged emitters are more prevalent in drip irrigation systems that do not use a filter due to low pressure. A laboratory experiment took place in the Experimental Hall of the China Agricultural University that tested emitter clogging based on type of emitter [14]. From this experiment it was concluded that turbulent flow emitters, such as the flag emitters, are the most successful at preventing clogging.

Pressure compensating (PC) emitters deliver constant flow rate for a specified range of operating pressures to compensate for minor elevation changes in output of the system. At ultra-low pressures the flow rate through non pressure compensating emitters and more complex PC emitters are very similar. The pressure range of these PC emitters are typically 10-40 psi or 30-50 psi but do not maintain a constant flow below the minimum pressure. The operating pressures of a gravity fed irrigation system with limited head pressure is too far below the PC emitters operating range to expect a control of flow. An experiment was undertaken at Agriculture Science Center at Farmington (ASCF) in 2010 to determine which emitters would be suitable for use in low-pressure systems [15]. The experiment tests the uniformity of various emitter models in low pressure drip systems and shows the relationship between flowrate and uniformity. The experiment showed that NC emitters were proficient at uniformly supplying water at low pressures.



Figure 7. Example of various drip emitter styles. [16]

Model #	Color	GPH @ 15 PSI
● DTA1	Black	1.0
● DTA2	Blue	2.0
● DTA4	Green	4.0

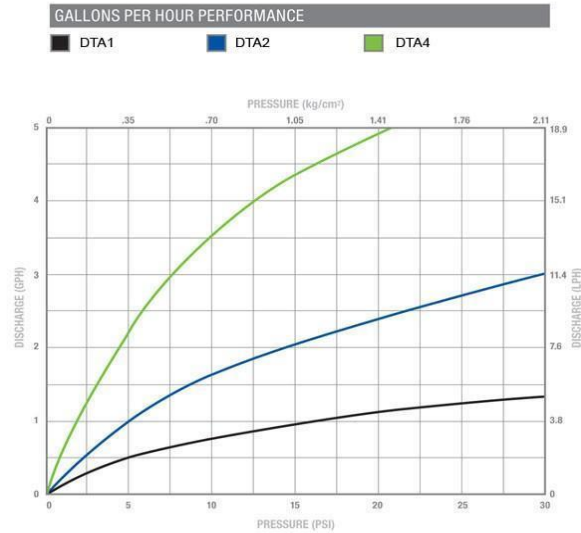

Figure 8. Graph depicting the operating pressure of the current prototype system. [17]

2.3.3 Frictional Losses

Frictional losses are present in all standard irrigation systems. Frictional loss is the loss of pressure due to the friction of water moving inside the pipe. This loss of pressure reduces the actual head pressure that reaches the outlet of the drip emitter. Pressure loss is also caused by other disturbances in the flow such as fitting connections and the interface between the drip line and the emitter [18]. To limit these losses, larger than normal, one and a half-inch or larger drip lines are used. This reduces the frictional loss in the piping by increasing the distance from the center of the pipe where there is full flow to the pipe wall. Increasing the pipe diameter also decreases the pressure loss due to how the emitter is attached to the pipe [6].

3 Objectives

A personal, home-garden, irrigation system needs an updated support structure, and manifold to effectively deliver water throughout the garden at low pressures (<10 psi). The support structure should be modular to accommodate a variety of water tanks/containers, ranging up to a 55-gallon drum with a bulkhead fitting outlet. Any irrigation component used should be able to interface with standard parts found at retail hardware stores. The project sponsor, Tina Creel would like

an inexpensive, fully-refined system that can be introduced to the consumer market. The system should be simple to use, durable, adjustable, and be able to reliably deliver water to plants/crops.

In order to accurately capture the scope of the project, a boundary diagram of the system was drawn. This diagram specifies which aspects of the product are included in the design. Everything within the dotted boundary is included in the scope of this project and everything that lies on the outside is not. This diagram is pictured in Figure 9.

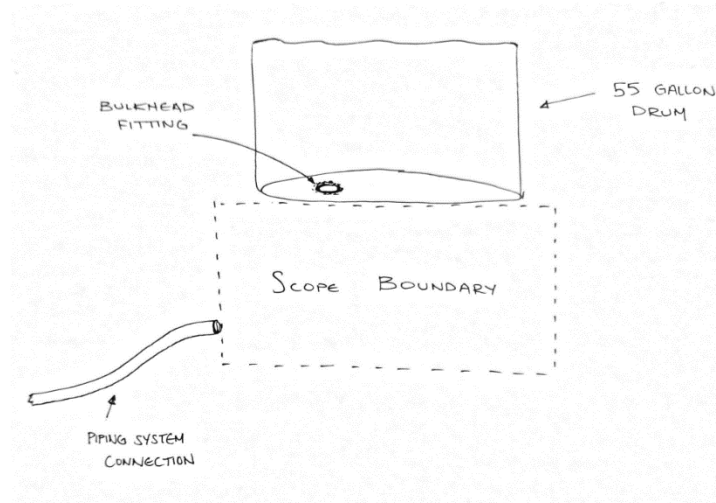

Figure 9. Boundary Diagram Sketch. Design considerations include the support system for the tank and the front facing manifold to which hoses are connected.

3.1 Design Considerations

Our interview with our sponsor provided us with specific needs and wants for the end product. The “needs” are aspects of the completed design that the project will not function without. The “wants” are aspects of the design that are not necessarily crucial for the product to function but are instead features that enhance the product and may set it apart from similar products.

The product must of course have the ability to reliably supply water to the soil. For this to happen, the system must have adequate head pressure and therefore must be elevated above the bed. The supports must have the ability to safely support a full 55-gallon drum barrel which weighs approximately 550 lbs. The barrel should be firmly supported without any chance of buckling or tipping. The stand should however have the ability to adjust to fit tanks of a lesser diameter and volume.

The system will not require any external connections to water or power. The only input from the user will be filling the tank with the desired volume of water and opening the valves to begin

flow. The system will be able to store water through the use of valves in the case that watering is not desired until a later time.

The system will have a manifold on which to connect the water lines on the front face of the storage tank. This will allow for a much easier set up and maintenance of the system. The tank will be custom made so that the manifold can sit on the lower front face of the tank and uniformly distribute water to the lines.

This product will be easily assembled/disassembled and easily repairable. In order to accomplish this, the majority of parts will be sourced so they are easily replaced. The system will not experience any loads besides its own weight and does not require significant pressure in order to function, so most interconnections between parts will either be threaded or snap fit. This will allow any malfunctioning parts to be easily removed and replaced with an off the shelf item.

3.2 Quality Function Deployment

In order to ensure that our project plan meets the required specifications, a QFD (Quality Function Deployment) table was developed. This table can be referenced in Appendix A. The QFD process began with determining who will be using our product; in our case, small irrigation users, garden supply, and florists. Next, the project goals such as water storage, reliable water delivery, durability etc. taken from our sponsor were inputted. If the design goals are able to be quantified through testing, the test is listed at the top of the QFD table. Goals that are not quantifiable through product testing our still taken into consideration. This table also allows us to compare existing products to ours so that we can ensure that ours more accurately solves the design problem. This table provides us with a concise overview of our customer, their wants and needs, and how they will be tested to ensure they meet specifications. The results of the QFD table suggests that zero leakage is the primary specification that must be accounted for. This makes sense because leakage will not only affect the pressure the system supplies, it will also lead to water waste. Another conclusion drawn from the table is systems that utilize electronic flow controllers are better at meeting some of the design goals than the current product, albeit at a higher cost. The possibility of implementing electronics into the system will be explored in the ideation phase of the project.

3.3 Engineering Specifications

The engineering specifications are the product “wants” and “needs” that are quantifiable through testing. These specifications are categorized as being either low, medium, or high risk. The higher the risk, the more likely the group will fail to deliver within spec. For this project, the most important specification is the system’s ability to sustain a sufficient head pressure. This is a fundamental function of the system and is needed for the system to operate. However, we don’t consider this a high-risk specification because the head pressure is simply a function of tank height above the bed. The tank need only be raised if it fails to initially supply the required

pressure. The complete list of engineering specifications to be tested are presented in Table 2. The table also contains our requirement and tolerance for each specification, as well as the specifications compliance, or how it will be examined to ensure it meets the specification. The methods used will be by testing (T), analysis (A), inspection (I), and similarity to existing products (S).

Table 1. System Specifications and Target Values.

Parameter Description	Requirement	Tolerance	Risk	Compliance
Head Pressure Supplied	1 psi	Min	L	T,A
Load Supported	550 lbs	Min	H	T,A
Height	3 feet	Max	M	I
Width	2 feet	Max	L	I
Depth	2 feet	Max	L	I
Weight	40 lbs	Max	H	I
Leakage During Full Tank Drain	0 mL	Max	L	T,A
Assembly Time	15 mins	Max	M	T,S
Drop Test	5 feet	Min	L	T

Two high-risk specifications we have listed are the weight parameter and the system’s ability to support 550 lbs. The sponsor desires the system to be able to support a completely filled 55-gallon drum (about 550 lbs) and therefore it will most likely have a metal support structure. The weight of the metal could add up quickly and result in the system becoming too heavy. The justification for the weight parameter is to ensure the system will be able to be carried comfortably by a single person. These parameters were listed as high-risk because the design of a sturdy support system will result in higher weight, while a lightweight design sacrifices strength. Designs which minimize the weight of the support system while maintaining load security will be explored in the ideation stage. The rest of the engineering specifications include the designs dimensions, assembly time, and its ability to survive a drop. The dimensions are included as a target specification in order to minimize the size of the system. A large system requires more materials, is generally more expensive, and will take up more space in the user’s garden.

Minimizing assembly time to more than 15 minutes was also included as a target specification. A simple to use, quick to set up system is much more marketable than one that requires hours of setup time or special tools. A drop test was included to ensure the robustness of the system. The system may experience drops and other forms of abuse due to it being located outdoors.

4 *Concept Design*

The concept design process began shortly after presentation of the Preliminary Design Review. This iteration of the design process was used to present some possible design solutions to the newly scoped project. It was used to narrow down which concepts might serve as viable design solutions, as well as to highlight some of the pitfalls that each concept presents.

4.1 *Concept Design Process*

The process for generating potential system designs started with three brainstorming sessions. The goal of these sessions was to foster creative thought within the group so that as many solutions as possible could be put forward. Ideas ranged from elementary solutions to outlandish and extravagant ones. The goal of these sessions was more focused on *quantity over quality*.

The three brainstorming sessions consisted of two ‘classic’ brainstorming sessions and one brainwriting session. For the classic brainstorming sessions, the critical functions of the system (supports tank, controls water, moves water) were first written on a whiteboard. Next, each group member wrote as many potential solutions to one of the functions as they could on sticky notes and placed them on the board underneath the corresponding function. This process allowed group members to be inspired or build off ideas put forward by the other members. When the group ran out of ideas, the process restarted with the next critical function.

The brainwriting was a less structured ideation session. Each group member took five minutes to draw out any idea they wanted. The drawing could either be the entire system, or an idea for a specific function. This process was repeated three times so a total of nine ideas were drawn out in the span of fifteen minutes.

In the previous iteration of the design process, rough concept models were created at this time to better visualize how concepts would look in three dimensions. However, due to lack of time, this iteration concepts were created in Solidworks in order to be compared and analyzed. Top concepts following brainstorming are presented in the following section.

4.1.1 Top Concepts

The following figures are 3D renderings of top concepts following the change of the project scope. The first concept is presented below in Figure 10.

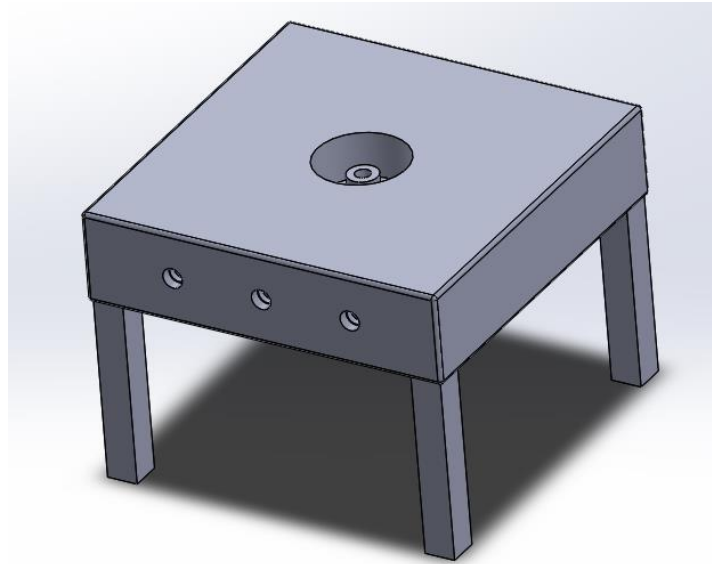

Figure 10. Box Stand Concept

This concept represents a method for supporting the water tank and providing an easily accessible location for the hookup of hose lines. One benefit of this design is it has a sturdy shape that is also easily manufactured. Additionally, it would not be difficult to modify the legs so that they could fold up into the box so the system could collapse down into a compact shape for easy carrying. An issue with this concept is its ability to secure a drum barrel. The bottom of drum barrels is oftentimes not flat and has a slight taper. A barrel placed on top of this stand would have the tendency to rock back and forth in high winds or with a slight bump. This could result in the bulkhead connection in the center snapping and a heavy barrel toppling over the stand. Modifications would have to be made to the stand in order to ensure the barrel is secured in place. Another concept is presented below in Figure 11.

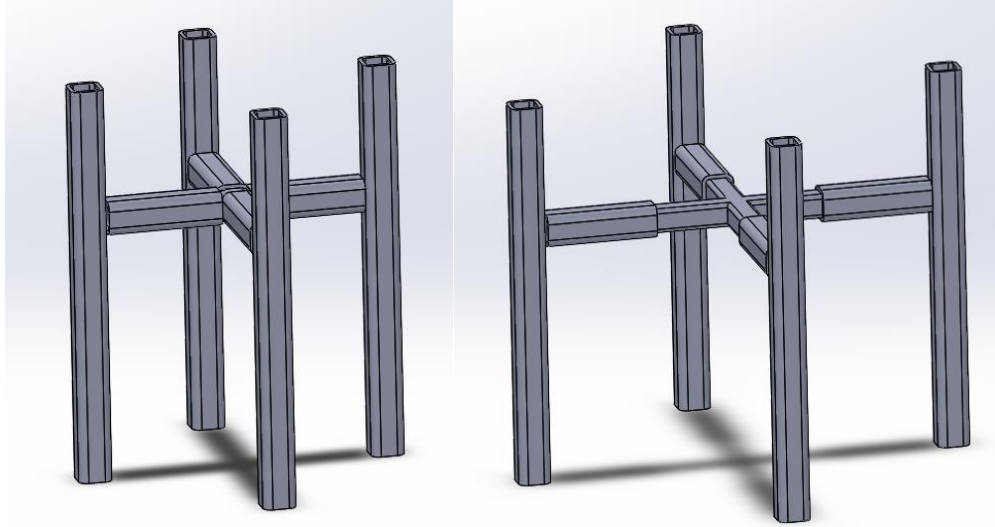

Figure 11. Telescoping legs concept design.

This concept presents another solution for the support of the water tank. This design features telescoping members with arms that allow for the support of various sized tanks/barrels. One issue with this design is the location of the front facing manifold. Since the majority of members are not fixed, it would be difficult to find a location to place the manifold. The benefit of this design is the increased base of the support that is provided when larger tanks are secured into the system. This results in a stand that is less prone to tipping. The final top concept is similar to this design and is presented below in Figure 12.

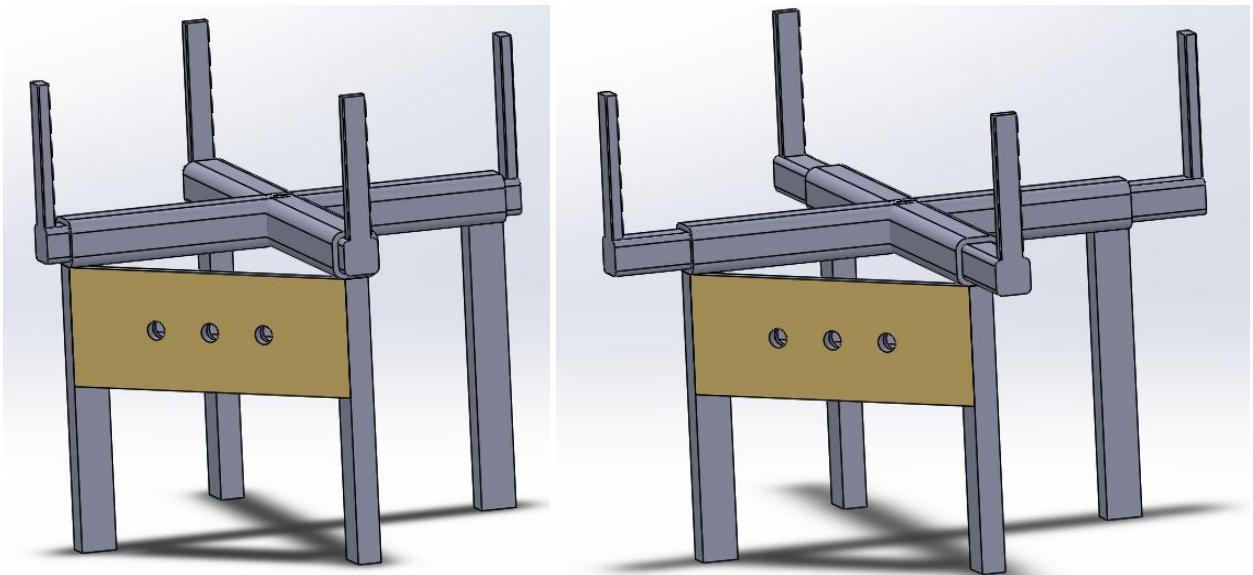

Figure 12. Telescoping arms concept design.

This concept represents an alternate method to secure the tank via telescoping. With the legs now being fixed in place, the manifold can now be easily secured across the front of two legs. This also opens up the option to fix up to four manifolds across the front of each of the four sides. A downside to this approach is its danger to tipping when the arms are fully extended, and a large tank is secured inside. Unlike the previous concept, the base of support does not widen.

4.2 Chosen Concept

After much discussion and analysis, the telescoping arms concept was determined to be the design best suited to fulfill the sponsor's requirements. This option yielded the greatest theoretical functionality for the system and met all of our highest weighted criteria at a satisfactory level. The advantage it has over the box concept is its ability to accommodate varying bucket sizes with ease. The advantage it has over the telescoping stand concept is the ease in which adjustments can be made to the width of the support arms. This is because the telescoping legs are in contact with the ground the stand must be lifted in order to make adjustments. Another advantage this design has over the telescoping legs concepts is the ease in which a manifold could be installed. With the legs being fixed in place, a manifold plate could either be welded or bolted across the front of two legs. Hoses could then be easily attached and detached from the manifold by the user. The manifold setup is shown below in Figure 13.

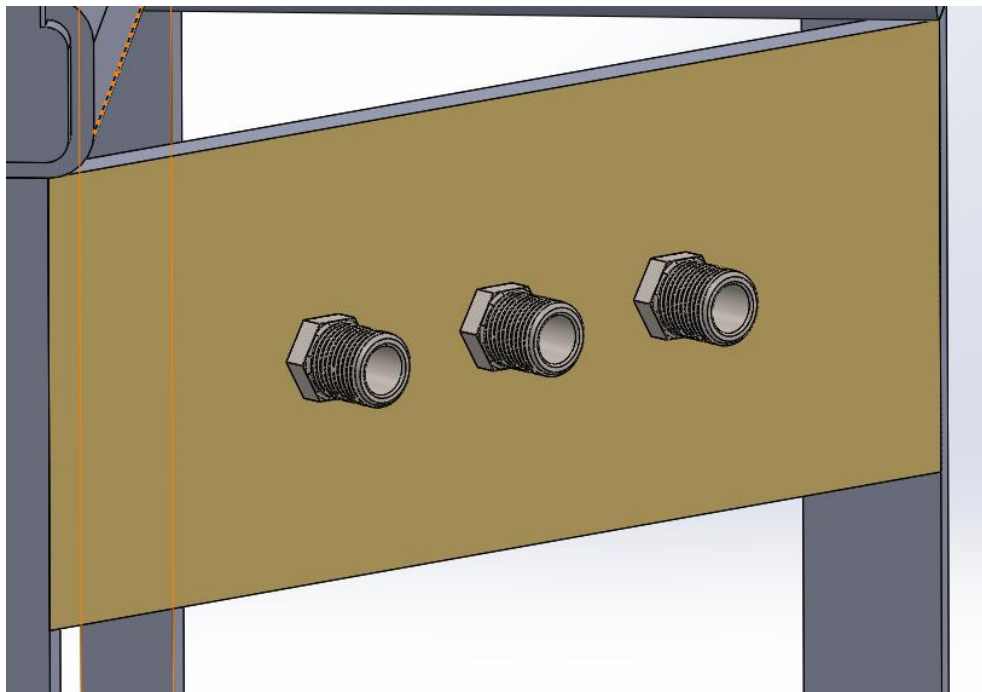

Figure 13. Front-Facing Manifold Concept

To control flow to separate lines, the option is available to install ball valves on the manifold outlets before reaching the hoses. This allows the user to dictate which sections of their garden to target with watering or will allow the user to stop flow completely if no watering is desired at the time.

4.3 Concept Risks and Challenges

There are a few risks associated with this design direction. As previously discussed, the base of support does not widen along with the arms. This may result in a support system that is not as sturdy when coupled with a large diameter barrel. The challenge will be to design the frame to be secure even when the largest compatible barrels are placed inside. Modifications to the frame that increase its support will be explored in future iterations. Another challenge associated with the chosen concept is the weather proofing of all materials. The structural members need to be resistant to corrosion and rust so that their strength will not degrade overtime. Additionally, any components that may contain standing water must be treated so that they don't corrode. The final design challenge is limiting the weight of the design. Since the support system will be made entirely out of steel, there is a risk of the design becoming too heavy for easy use. The team is confident that all of these design challenges will be worked out as the last details of the final design are established.

5 Final Design

The final design for the Gravity Drip Irrigation is a further refined version of the chosen concept presented in the previous chapter. In this chapter, the overall design will be explained and the subsystems that make up the design will be broken down and analyzed. Following this, a discussion of the evidence collected that supports choices made during the design process will be presented. Safety concerns will be addressed along with a discussion of maintenance repair for the overall system. Finally, a cost breakdown of the entire system will be presented.

5.1 Design Description

The driving factors in the design of the gravity drip irrigation system are the two main design criteria specified in the re-scoping of the project. The support of a full 55-gallon barrel, and the delivery of water from the barrel's bulkhead outlet to a front-facing manifold to which hose lines could be connected.

Since the sponsor expressed interest in a modular design, the support system was designed to integrate barrels of varying dimension. This is accomplished through the use of telescoping support arms. These arms allow for user flexibility when choosing what size water tank they

want to implement into the system. The arms interface with a sturdy base which is used to elevate the barrel above ground so that adequate head pressure can be supplied downstream. Another feature of the design is a front facing manifold that allows the user to easily connect and disconnects hose lines. The standard size threaded outlets leave the option open to the user to implement ball valves before the connection of hoses. A 3D rendering of the final design can be seen below in Figure 14.

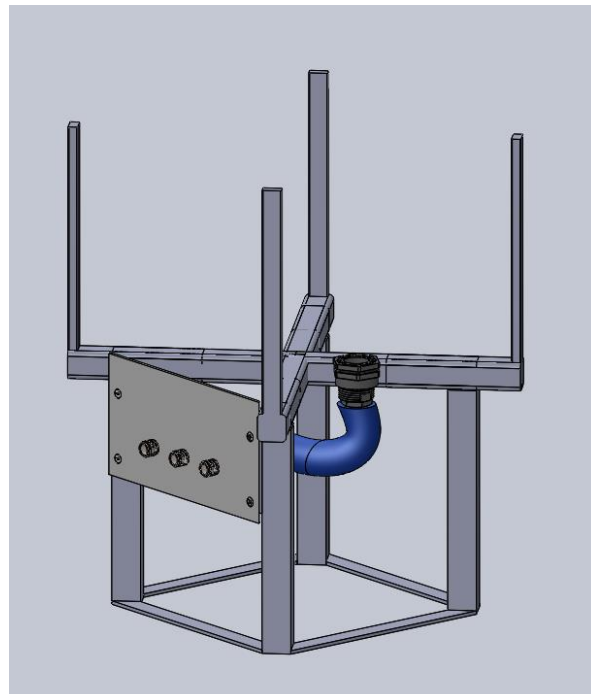

Figure 14. Full compact assembly of frame and piping connections.

The final design contains two major subsystems that work concurrently in order to meet the sponsor's desired system parameters. The first subsystem is the modular support system for the water tank. The support system is made mainly out of stock mild steel tubing cut to size and welded to shape. The only exception being the flat base at the bottom which is 3/16" mild steel bar stock. The support subsystem is shown in Figure 15.

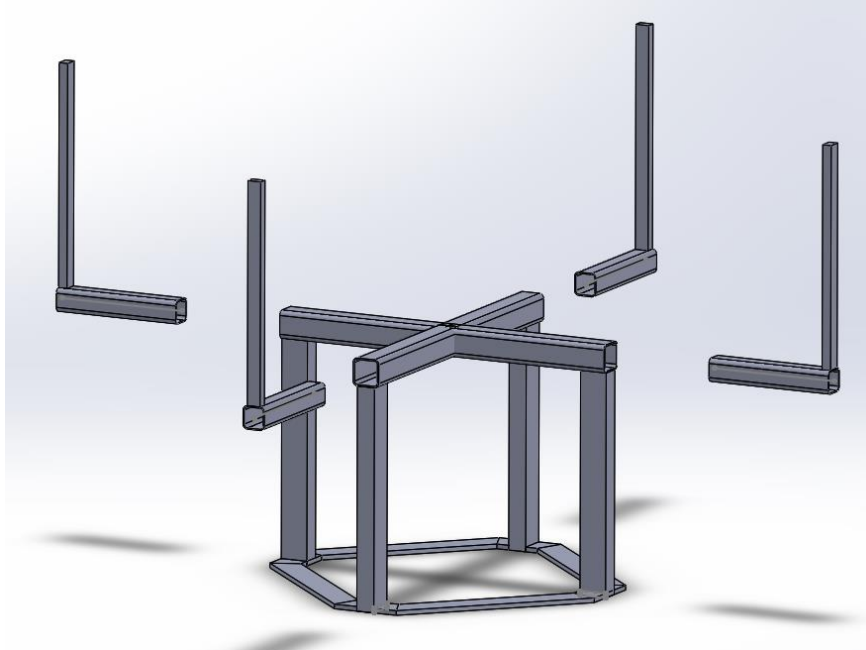

Figure 15. Exploded view of welded support frame and telescoping arms.

The top cross section of the base on which the water tank will rest is made out of 1.5x1.5x0.083-inch mild steel square tubing. The support arms are the next size smaller so that they can telescope in and out of the stand. The support system is able to support drum barrels ranging in size from 30-gallon drums all the way up to 55-gallon drums. Extra travel is included in the arms so that barrels of non-conventional shape and slightly larger dimension may be inserted into the system. Once the arms are secured in the desired position, they will be locked in place using a star knob. A close up rendering of the locking mechanism is shown below in Figure 16.

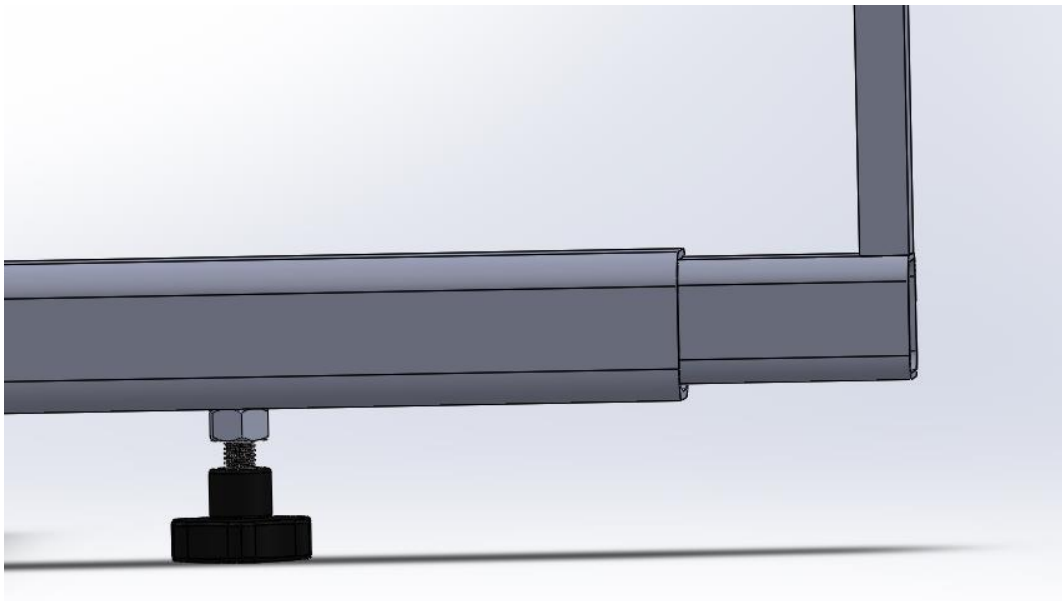

Figure 16. Telescoping arm and locking mechanism.

The locking mechanism consists of a 3/8-inch hex nut welded to the outside of the square tubing. A sourced star knob is threaded into the nut and through the square tubing where it will contact the inner tube, locking it into place. The user will be able to easily adjust the width of the support arms by loosening each of the four star knobs, sliding the arms into place, and retightening the knobs until the arms are secured in place.

The second subsystem in this design is the piping subsystem. The piping subsystem's essential function is delivering water from the bulkhead outlet located on the underside of the drum barrel to the front face of the manifold. A compact and an exploded view of the piping subsystem is shown below in Figure 17.

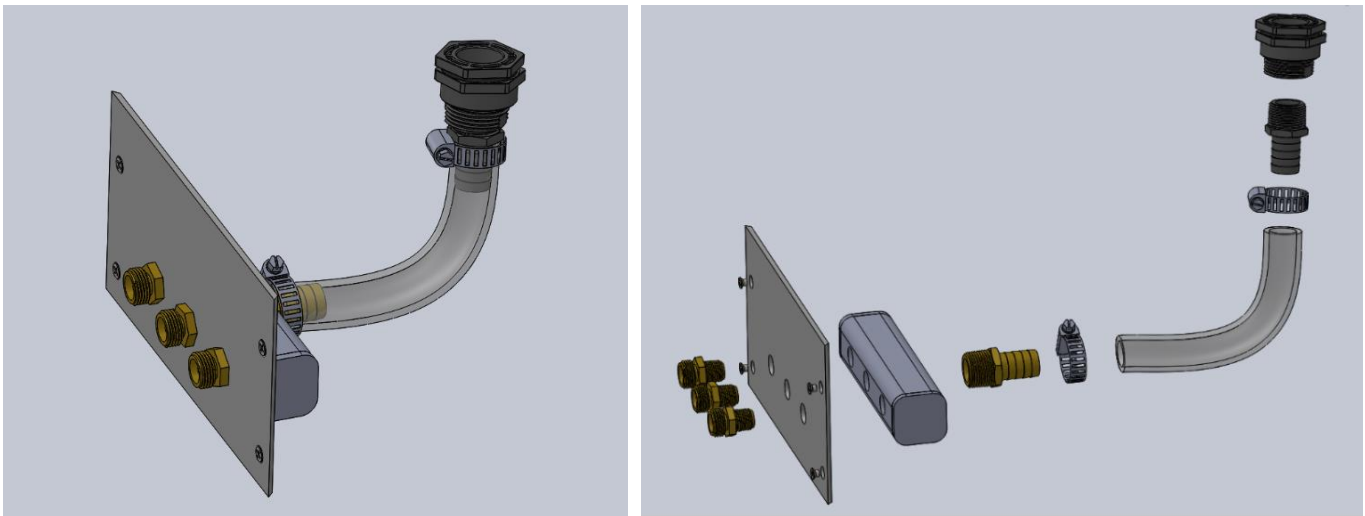

Figure 17. Piping Sub-system assembly, compact (left) and exploded view (right)

For the piping sub-system, there were two primary objectives,

1. Design the system to minimize the number of custom manufactured parts.
2. Design the system to be fully detachable from itself as well as the frame/bucket

Meeting these two objectives optimized the cost and the modularity of the piping sub-system. Sourcing as many stock parts as possible for the system, instead of custom manufacturing, significantly decreases cost, as most basic irrigation components are inexpensive and can be replaced easily. Choosing this method of component selection also increases system modularity, as stock irrigation components are generally detachable and reusable.

The entry of the piping system only consists of basic irrigation components. A standard bulkhead is attached to the bucket and acts as the water's inlet to the system which is then connected to

threaded barb adapter, a 1-inch tube, another threaded barb adapter, and is secured by a hose clamp over either barb. This simple piping section leads into the manifold which is the first custom manufactured part.

The manifold for the system is modeled after aluminum block manifolds that are commonly used in pneumatics for fluid flow splitting, shown in Fig. 18.



Figure 18. Example of a pneumatic manifold made of anodized aluminum.

Due to the tight tolerances held in this type of manifold, their costs are higher than what the project budget can afford. However, if the sponsor chooses to move forward with this design concept, manufacturing drawings and plans will be created outlining requirements for production of an aluminum or plastic manifold that is more directly suited for irrigation purposes.

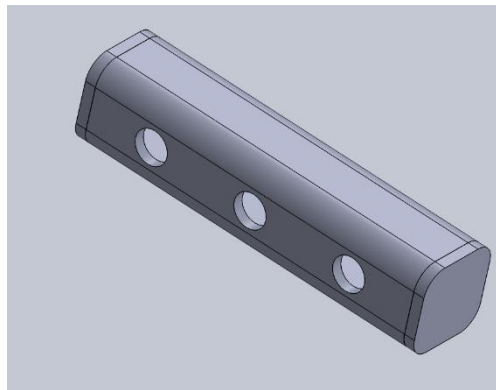

Figure 19. Manifold prototype, constructed of thick wall steel tubing with capped ends.

Since the pneumatic manifold isn't an acceptable solution for this system, a prototype manifold will be manufactured instead to demonstrate the functionality at a lower cost. The prototype

manifold will be made with thick-wall ($>.25''$) steel tubing capped off and $\frac{3}{4}''$ holes tapped with pipe threads shown in Fig 19. This will simulate functionality for the prototype but is not a reasonable solution for high volume production. To prevent the prototype from experiencing significant corrosion when installed in the piping system, steel-finishing techniques such as galvanizing will be explored during manufacturing.

At the front of the manifold, a faceplate shown in Fig. 20 and three garden hose adapters attach via pipe threads.

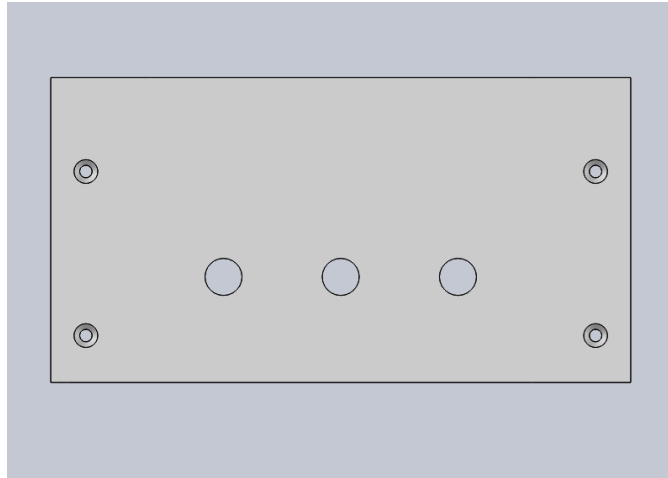

Figure 20. Manifold faceplate with drilled holes for hose adapters and flathead bolts.

The faceplate, which is secured to the frame sub-system, acts only as a locator (ie. non-threaded, clearance holes) for the manifold holes and will be pulled flush against the manifold by threading the hose adapters into the manifold holes. The standard adapter outlets will be male ends with garden hose threads shown in Figure 21, but a user could easily source replacement adapters of any size if their piping system contains connections of a different size.

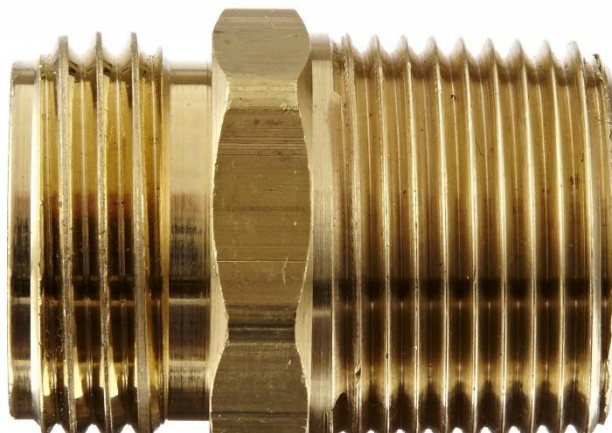

Figure 21. Garden Hose Thread to Pipe Thread adapter which pulls the faceplate flush against the manifold when fully threaded.

5.2 Design Justification

The project as a whole was driven largely by the design requirements and budget, and because of this, some elements of the prototype are overdesigned. This is particularly evident in the frame sub-system, which utilizes thick-wall, steel tubing that has strength properties that far exceed the requirements for this project. However, selecting steel tubing for the frame presents a few considerable advantages to other solutions and materials, which are the ability to telescope, weldability, and cost. All three of these advantages made overdesigning the frame the correct decision in comparison to optimizing the structure's dimensions and materials for the anticipated loads which would have resulted in drastically increased costs. With these considerations in mind, we moved forward with multiple design calculations, which are outlined in detail in Appendix B, anticipating that the structure would meet and exceed our design specifications.

Support legs were the first components considered and they were checked for buckling under the full weight of the bucket, approximately 550 lbs. By applying the entire bucket weight to a single support leg, any eccentric loading (ie. placing the frame on an uneven surface) was accounted for and a conservative Factor of Safety could be determined. After carrying out the calculations, the Factor of Safety for the support legs was greater than 600 which confirmed that the frame support-structure significantly exceeds the design specifications.

The next considerations were the butt and fillet welds that connect the short members to the cross-frame that directly supports the bucket. These weld groups are the most likely place for shear failure to occur in the structure, so in order to confirm that the welds would hold, an unfavorable loading scenario was applied to the cross-members that resulted in both transverse and bending shear in the welds. Even under these unlikely loading conditions, the Factor of Safety for weld failure was approximately 20 which further ensures the structural integrity of the frame. For reference, typical Factors of Safety for a design similar to this would be much lower, likely between 1.5 and 3.

Finally, and most importantly, is the potential safety concern of tipping. This was the most critical design specification due to the potential for a loaded 500 lb barrel to fall on and injure someone. We designed the leg base so that when the barrel is between 50% and 100% full, an average adult male is unable to exert enough force to push over the bucket/frame. This will be a focal point of further testing upon the prototype's completion.

5.3 Safety

The gravity drip irrigation system does not include any moving parts, electricity, pressurized gases, or toxic material and is therefore a very low risk design. A checklist of potential design hazards associated with the design of products is presented in Appendix C. One hazard

associated with the system is the heavy weight of the water tank elevated off the ground. This represents a possible dangerous situation in which the system tips over while holding a full water tank. The tipping tank could cause injury to a user standing nearby the system. The planned preventive for the tipping hazard is extensive testing of the confirmation prototype to ensure that any potential forces that the system will undergo will not result in the tipping or collapse of the base.

The second and final hazard marked in the Design Hazard Checklist is the products' exposure to extreme environmental conditions such as fog, humidity, and cold/high temperatures. Due to the nature of the product, it will spend almost the entirety of its life outdoors and uncovered. This raises questions about the safety of the system following degradation from weather exposure. The planned preventive measure for this hazard is a weather-proofing treatment of all materials used in the system.

5.4 Maintenance and Repair

In order to ensure a long lifetime for the Gravity Drip irrigation system, the design has been simplified so that it uses many off the shelf components. This allows the user to easily isolate and replace damaged or malfunctioning components. The exception to this being the tank support subsystem. The structural members of the support system are made entirely out of steel and will be weather-proofed to protect against extreme weather conditions. This ensures that this subsystem will have a satisfactory lifetime with normal use.

5.5 Failure Modes and Effects Analysis

Failure Modes and Effects Analysis (FMEA) is the process by which possible circumstances in which the system may fail and their resultant effects are broken down and analyzed. A detailed FMEA for the Gravity Drip irrigation system is presented in Appendix D. The FMEA allows for all potential failure modes and their severity to be quantified so that preventive actions may be prioritized. The priority for preventive measures is determined by three variables, the severity of the failure mode, likelihood of occurrence, and the ease in which it is detected. The highest priority failure mode for the Gravity Drip system is the collapse of the support system base. The possible effects of this failure mode are the potential injury to the user as discussed in section 5.3, or the damage of the user's garden/property. The potential causes of this failure mode are the buckling of the stands legs or the failure of welds between structural members. While this failure mode carries a high severity rating, it is easily preventable via load and weld analysis and extensive stress testing of the stand.

5.6 Cost Summary

Every component in the irrigation system is either modified from inexpensive stock metal suppliers or sourced from irrigation suppliers. The budget for the entire project including prototyping materials totals \$500. A simplified bill of materials that accounts for planned purchasing for the confirmation prototype is presented in Table 2 below.

Table 2. Simplified Bill of Materials

No.	Subassembly	Cost
Stand		
1	1.5"x1.5"x0.083" Mild Steel Square Tubing	\$14.00
Locking Mechanism		
2	3/8" Square Nut	\$0.96
3	3/8" Star Knob	\$15.99
Base		
4	3/16"x1" Mild Steel Bar Stock	\$7.50
Arms		
5	1.25"x1.25"x0.065 Mild Steel Square Tubing	\$7.40
6	3/16"x1" Mild Steel Bar Stock	\$5.00
Manifold		
7	1.5"x1.5"x0.083" Mild Steel Square Tubing	\$1.75
Faceplate		
8	6"x12"x0.1875" Mild Steel Sheet	\$5
Tabs		
9	3/16"x1" Mild Steel Bar Stock	\$1.25
Piping		
10	1"x1" Brass Barb x MPT Adapter	\$6.48
11	PolyCarbonate Tubing	\$2.19
12	Garden Hose Adapter	\$14.79
13	1" NPT x 1" Hose ID Black HDPE Adapter	\$1.07
14	1" Polypropelyne Bulkhead Tank Fitting 2-1/4"	\$8.41
15	1-3/4 in Stainless-Steel Clamp	\$2.20
Estimated Cutting Costs		\$20.00
Estimated Shipping Costs		\$15.00
Total		\$128.99

The simplified bill of materials also contains an estimate of cutting costs charged by steel suppliers. Although the bill of materials also contains estimated shipping costs, the team is confident most parts can be sourced locally. It was included so that the overall cost reflected a more conservative total. The total cost comes in well under the budget of \$500 and leaves room for the exploration of finishing processes on materials used in the irrigation system. An expanded bill of materials that includes more detail, as well as supplier information and part numbers can be referenced in Appendix E. Additionally, product literature for all sourced parts can be found in Appendix F.

6 Manufacturing

The following plan outlines all information required for the manufacturing of the confirmation prototype. Material procurement, manufacturing processes, and assembly are broken down step by step so that the manufacture of the confirmation prototype could be easily replicated.

6.1 Material Procurement

The Gravity Drip Irrigation System is made entirely of either stock steel cuts that can be found at most any steel supply shop and general irrigation components that can be found at home depot. The abbreviated bill of materials showing the final budget for the prototype is shown below in Figure 22.

No.	Subassembly	Quantity	Cost
Stand			
1	1.5"x1.5"x0.083" Mild Steel Square Tubing	8 ft	\$14.00
Locking Mechanism			
2	3/8" Square Nut	4	\$0.92
3	3/8" Star Knob	4	\$15.99
Base			
4	3/16"x1" Mild Steel Bar Stock	6 ft	\$7.50
Arms			
5	1.25"x1.25"x0.065 Mild Steel Square Tubing	4 ft	\$7.40
6	3/16"x1" Mild Steel Bar Stock	4 ft	\$5.00
Manifold			
7	2"x2"x0.250" Mild Steel Square Tubing	5 ft	\$35.71
Piping			
8	1"x1" Brass Barb x MPT Adapter	1	\$6.48
9	PolyCarbonate Tubing	2	\$5.98
10	Garden Hose Adapter	3	\$14.79
11	Banjo HB100 Hose Fitting, Adapter, 1" NPT Male x 1"	1	\$5.29
12	Banjo TF100 Bulkhead Tank Fitting, 1" NPT Female	1	\$9.79
13	1-3/4 in Stainless-Steel Clamp	2	\$3.98
Total			\$133.12

Figure 22. Abbreviated BOM

Note: The expanded bill of materials is located in Appendix E.

6.2 Manufacture

The following section goes through the step by step procedure used to construct the prototype. Additionally, the machinery necessary to complete each step is described. Detailed part drawings for all manufactured parts discussed can be found in Appendix G.

M1 – Cut stock material to length using a circular saw to form cross frame, legs, and arms.

Material: 1.5”x1.5”x0.065” Square mild steel tubing – 8’ total needed.

1. Quantity (2) – (9”) 90 degree cut on both ends to form opposing members of cross frame.
2. Quantity (1) – (18”) 90 degree cut on both ends to form central member of cross frame.

Material: 1.25”x1.25”x0.65” Square mild steel tubing – 6’ total needed
1.25”x1.25”x0.65” Square mild steel tubing – 6’ total needed.

1. Quantity (4) – (12”) 90 degree cut on both ends to form vertical support portion of arm.
2. Quantity (4) – (9”) 90 degree cut on both ends to form inner telescoping portion of arm.



Figure 23. Cutting of system cross frame and legs to their appropriate lengths.

M2- Cut leg brackets to size.

Material: 1.5”x0.1875 Flat stock mild steel - 4’ total needed

1. Quantity (4) – Cut 18’ lengths with 45 degree cuts at each end.

M3 – Assemble welding fixtures.

A simple welding fixture attached to a welding table is required to keep angular and distance relations between parts accurate during welding.

Fixture 1- Aligns the three pieces of the cross frame to keep relative angles at 90 degrees. The fixture allows the part to be removed and reattached to complete all welding as required. The same fixture can be used to weld the arms and keep the relative angles at 90 degrees.

Fixture 2- A vertical section of square tubing or angle iron used to hold the legs of the frame at 90 degrees while they are welded.

M4 – Welding the cross frame.

1. Place the two smaller cross frame sections on either side of the long one inside Fixture 1 and clamp down.
2. Tack both small sections one at a time to the long section.
3. Ensure that the sections are oriented 90 degrees with respect to the long section.
4. Clamp the frame back into the fixture and complete the welds. To minimize warping, welding should be completed by alternating between different areas in the frame.
5. Allow frame to cool in the fixture.



Figure 24. Tacked cross frame.

M5- Welding the legs.

1. Transfer the cross frame to Fixture 2. This fixture allows the legs to be secured and held at 90 degrees to the base while being welded.
2. Like the previous process, first tack the legs, verify that they are oriented at 90 degrees, and then finish each of the welds, alternating sides throughout.
3. Allow the frame to cool in the fixture.



Figure 25. Cross frame with welded leg supports.

M6- Welding the leg brackets.

1. Place the frame on a table and locate the brackets between the legs. The brackets should hold the legs square.
2. Tack and weld each of the brackets to the legs.
3. Let frame cool.



Figure 26. Frame with welded leg brackets.

M7- Drilling the arm lock and welding the lock nut.

Materials: 3/8" hex nut – 4 total needed

1. 3" from the outside edge of the cross frame on each arm, centerpunch, predrill, and final drill a 1/2" hole centered on the tubing.
2. Weld a 3/8" hex nut centered over each hole. Later a star knob with a 3/8" bolt is inserted into each hole and will be used to lock the telescoping arms in place.



Figure 27. Welding Frame Base

M8 – Welding the arms.

1. Secure the inner telescoping section of an arm and the vertical support section into Fixture 1.

2. Like the other processes, first tack the arms, verify that they are oriented at 90 degrees, and then finish each of the welds, alternating sides throughout.
3. Let arm cool in the fixture before removing.
4. Repeat for the three other arms.



Figure 28. Welded base frame with telescoping arms inserted.

M9 – Constructing the manifold. The manifold used in the prototype is a 2”x2”x0.25” wall tubing to simulate a machined manifold out of a solid aluminum block.

Materials: 2”x2”x0.095” steel tubing – 6” total needed

1. Cut the manifold to length using a ban saw.
2. Weld a cap over each open end.
3. For the inlet hole, drill a 1 5/32” hole tapped to 1”-11.5 NPT threads or drill an oversized hole and weld in a 1” bung as shown in Figure 29. Location specified in part drawings.

4. For the outlet holes, drill three 15/16" holes tapped to 3/4" -14 NPS threads or drill an oversized hole and weld in a 3/4" bung as shown in Figure 29. Location specified in part drawings. (Note: Tapping the tube wall or using a weld bung will both successfully create the manifold, however tapping requires a thick wall tube.)



Figure 29. Manifold with located and tacked weld bungs.

M10- Welding the manifold to the legs.

1. Lay the frame on its side on a table.
2. Lay the manifold on the backside of the legs and tack into place.



Figure 30. Fully welded frame assembly.

6.3 *Assembly*

A1 – Assembling the frame.

1. Set frame with legs down on the ground.
2. Slide each of the 4 arms into the tubes of the cross frame.
3. Insert the star nut bolt into the hex nuts on the underside of the cross frame.
4. Thread bolt in until arms lock into place.

A2 – Assembling the piping system.

1. Apply Teflon tape or pipe thread compound to the threads of all fittings.
2. Thread hose adapters into each of the holes on the front of the manifold.
3. Thread in the 1"x1" Brass Barb x MPT Adapter to the backside of the manifold.
4. Secure one end of the hose over the barb on the adapter and tighten with a hose clamp,
5. On the other end of the hose, insert the Banjo HB100 Hose Fitting, Adapter, 1" NPT Male x 1" and tighten down with the other hose clamp.

A3 – Assembling the Barrel

1. Locate and drill a 2 3/16” hole off center on the bottom of a drum barrel with a hole saw.
2. Insert the bulkhead fitting into the hole and tighten.
3. Thread the hose barb fitting into the bulkhead and tighten.

A faceplate was not included in the final assembly (as shown in concept design), our group felt that the aesthetics of the manifold alone was preferable over the larger faceplate.

7 *Design Verification*

This chapter explains how the prototype will be tested to ensure that it meets the specifications listed in Table 1. Each specification and its corresponding test plan will be discussed individually. Additionally, equipment needs for each planned test will be discussed. Detailed test plans can be referenced in Appendix H and a Design Verification plan summarizing all tests and results can be found in Appendix I.

7.1 *Specifications and Tests*

Tipping Test – Greater than 70 lbf required to tip at center of mass.

How prone the system is to tipping will be tested to ensure safety for those who will be using the product. Our research determined that an adult male is able to generate a lateral force of about 70 lbf from a standing position. The barrel will be tested to ensure that a force greater than this is required to push the barrel over. The test will be conducted by first tying a rope in line with a hook scale around the barrel and then pulling the barrel until tipping occurs. This test requires a level, open area, a towing winch, rope or straps, and a hook scale. Figure 31 shows the experimental setup.



Figure 31. Water loaded barrel with attached load scale.

Head Pressure Supplied – 1 psi

The head pressure supplied to the piping system will be tested to ensure water will be delivered to the entire length of the sponsors piping system and the emitters within the piping system will function properly. To conduct this test, a pressure gauge compatible with hose threads will be connected to one of the hoses leading out of the front manifold. The barrel will be filled with water and allowed to drain completely through the remaining two outlets. The pressure supplied to the hose line will be recorded as the tank transitions from being 100% full to completely empty. This data will be analyzed to determine the pressure supplied throughout the draining process is consistent with the required parameter.

Load Supported – 550 lbs

The ability to support the load of a full 55-gallon drum is the system's most critical parameter. With additional time and resources, the confirmation would be tested until failure to discover the max load that it is able to support. In this case, it will only be tested to the target weight. The test will consist of loading the support system with a full 55-gallon drum identical to what will be used during typical use of the product and measuring the deflection of the cross frame at its center point using a caliper. Any warping or sagging of the frame will indicate the system is near failure and unsafe. No additional equipment is required to conduct this test other than the 55-gallon drum and a caliper. Figure 32 below shows the test setup.



Figure 32. Preparing digital calipers to measure frame displacement under load.

System Dimensions – 2ft length x 2ft width x 3ft height

This parameter is low risk and is easy to test. The testing procedure is self-explanatory and only requires a tape measure.

System Weight – 40 lbs

This parameter is also easy to test. The weight of the system will be determined by having a group member stand on a scale holding the assembled system and then subtracting off the group members weight.

Leakage – 0 ml lost throughout full tank drain

The leakage parameter is critical to system function and will be tested thoroughly. A fully filled 55-gallon drum will be loaded into the prototype and the prototype will be connected to the sponsors piping system. The water will be allowed to fully drain out of the tank and through the hose connections. Obvious leakage points will be able to be identified through observation. To detect more subtle leakage points that may occur many hours into the drain, receptacles will be placed underneath each component interconnection. Any receptacle that contains water at the conclusion of the drain indicates a non-sealing interconnection above it. The only equipment required for this test is the sponsor's current piping system and receptacles to catch any leaking water.

Assembly Time – 15 mins

The assembly time parameter is in place to ensure the system is easily assembled by a typical user. To test the average assembly time, three volunteers will be provided with an instruction manual on how to assemble the prototype. The time it takes each volunteer to completely assemble the prototype after given the manual will be recorded. The data from ten trials will then be averaged to determine the typical user's time to assemble. This test requires no additional equipment and only needs the help of ten volunteers.

7.2 Test Results

The results for all tests outlined in the previous section are presented below in Table 3.

Table 3. Summary of Test Results

Test	Parameter	Result	Pass/Fail
Load/Deflection Test	<0.05 in No weld cracks	0.01 in No weld cracks	Pass
Tipping Test	<70 lbf at COM	110 lbs	Pass
Weight	<40 lb	20.3 lb	Pass
Dimensions	24 in width 24 in length 36 in height	14.5 in width 14.5 in length 25.5 in height	Pass
Leak Test	0 ml leakage	0 ml leakage	Pass
Pressure Supplied	>1 psi	1.1 psi	Pass
Assembly Time	<15 mins	2.5 mins	Pass

As shown in the table, all tests met the required parameters. However, the tip test was also conducted at varying heights along the barrel and it was found that it tipped at 70 lbf when the barrel was pulled from the very top. While this still qualifies as a pass for the tipping test, it should be noted that there is still a risk for tipping. In commercial use, warning labels would need to be displayed on the device to help prevent user injury and recommendations for reducing the tipping hazard will be included in section 9.

8 Project Management

The design and manufacture of the irrigation system took place over three quarters. The first quarter focused on defining the problem, background research, the ideation of designs, and finally the selection of a design. In the second quarter we finished the design, prototype, and

built the product. In the final quarter, the build was completed and tested. The timeline of key deliverables and events that took place throughout the project are presented below in Table 3.

Table 4. Project Deliverables and Key Deadlines.

DATE	Deliverable
11/6/2018	Concept CAD
11/8/2018	Concept Prototype
11/16/2018	Preliminary Design Review
1/22/2018	Structural Prototype
2/8/2018	Critical Design Review
3/14/2018	Manufacturing and Test Review
4/25/2018	Hardware/Safety Demo
5/31/2018	Final Prototype

In addition to these key deliverables, a Gantt chart is included in Appendix J that lays out a detailed schedule of all manufacturing and testing events. The Gantt chart includes all project tasks required to meet each deliverable, how much time they took, and which group member completed each task. The process that we followed throughout the year worked extremely well for our group. Having each task categorized and assigned to a group member resulted in clear communication of expectations. This resulted in our manufacturing process taking less time than expected and opened more time for design verification and testing. One aspect of the design process that our group would like to change would be to more accurately define the scope of the project before beginning design. This would have allowed for more time iterating a design that fits the scope perfectly.

9 Conclusion

This final design report outlines our team’s entire vision of the gravity drip frame and manifold system. The outcome of this project is a functional and multi-purposed prototype that can be utilized for potential marketing/sales development opportunities. The design requirements set for the project have all been successfully met and the prototype will be given to the sponsor for future use and design work. If we were to go back and do the project over again, there are a few aspects of the project that we would change. The first being that we would like to incorporate a

wider base of support for the frame. One possibility would be a trapezoidal shaped base with legs that angle out. This would help the system be less prone to tipping but comes with the cost of a more complex manufacturing process. Another aspect that we would alter in future iterations would be the implementation of a plastic manifold. The plastic manifold could be produced cheaply using injection molding and has the benefit of being both rust proof and light.

Works Cited

1. Tager, A., et al. Comparative Study of Drip and Furrow Irrigation Methods at ...International Journal of Agricultural and Biosystems Engineering, 2012.
2. Kidambi, Misha. Drip Irrigation: Getting More Out of Less. , IAEA, 21 Mar. 2010, www.iaea.org/newscenter/news/drip-irrigation-getting-more-out-less.
3. Georgiadis, Robert G. Jokey Plastik Wipperfurth GmbHGeorgiadis, Injection molded plastic bucket with an integrally moulded carry handle, US5526954A, United States Patent and Trademark Office, 1997-03-04
4. Marans, Elaine. Rain Bird Corporation. US 5820029A, United States Patent and Trademark Office, 1997-03-04
5. Stross, Amy. "5 Passive Irrigation Techniques That Make Watering Easier." Hobby Farms, 10 June 2016, www.hobbyfarms.com/5-passive-irrigation-techniques-that-make-watering-easier/.
6. Buckley, Adrian. "Water Harvesting and Storage." The Permaculture Research Institute, 3 June 2016, permaculturenews.org/2010/05/20/water-harvesting-and-storage/.
7. Kania, Bruce G., et. al, Fountainhead LLC, US20100200480A1, United States Patent and Trademark Office, 2009-02-10
8. Spring-Green. "Get Smart with Your Sprinkler System | Spring-Green." Spring Green, Spring-Green, 28 Feb. 2018, www.spring-green.com/blog-get-smart-with-your-sprinkler-system/.
9. Rain Bird. "1ZEHTMR - Electronic Garden Hose Watering Timer." Rain Bird, store.rainbird.com/1zehtmr-electronic-garden-hose-watering-timer.html.
10. Caers, et. al. Plasticised polyvinyl chloride. US7297738B2. United States Patent and Trademark Office, 25 September 2011.
11. Golan, et. al, Drip irrigation system.US7048010B2. United States Patent and Trademark Office, 2003-05-08.
12. Engineering ToolBox, (2010). Hydrostatic Pressure . [online] Available at: https://www.engineeringtoolbox.com/hydrostatic-pressure-water-d_1632.html

13. Jacobsen, Krista, and Brent Rowell. "On The Grid: Ultra-Low Pressure Drip Irrigation and Rainwater Catchment for Small Plots and High Tunnels." University of Kentucky HO-120 College of Agriculture, Food and Environment Cooperative Extension Service, www2.ca.uky.edu/agcomm/pubs/HO/HO120/HO120.pdf.
14. Haijun, Liu, and Huang Guanhua. "Laboratory Experiment on Drip Emitter Clogging with Fresh Water and Treated Sewage Effluent." *Agricultural Water Management*, Elsevier, 24 Dec. 2008, www.sciencedirect.com/science/article/pii/S0378377408002795#aep-bibliography-id27.
15. Smeal, Dan, et al. Performance of Drip Irrigation Emitters at Low Pressure. 15 Nov. 2014, aces.nmsu.edu/aes/agroforestry/documents/low_pressure_drip_utopia.pdf.
16. "[Hot Item] China Watering Plastic Dripper Irrigation Emitters." Made-in-China.com, qingcheng2010.en.made-in-china.com/product/PSfnKjbAbUpF/China-China-Watering-Plastic-Dripper-Irrigation-Emitters.html.
17. "Dig Water Matters." DIG TOP Twelve Outlet Drip Irrigation Manifold Head with ½ Inch FPT, digcorp.com/professional-irrigation-products/12-outlet-top.
18. Bagarello, V., et al. "Evaluating Pressure Losses in Drip-Irrigation Lines." ASCE Library, American Society of Civil Engineers , 1 Jan. 1997, [ascelibrary.org/doi/abs/10.1061/\(ASCE\)0733-9437\(1997\)123:1\(1\)](http://ascelibrary.org/doi/abs/10.1061/(ASCE)0733-9437(1997)123:1(1)).

Appendix A - QFD Table

Correlations	
Positive	+
Negative	-
No Correlation	

Relationships	
Strong	●
Moderate	○
Weak	▽

Direction of Improvement	
Maximize	▲
Target	◇
Minimize	▼

QFD House of Quality
 Project: Gravity Drip Irrigation
 Revision Date: 16 October 2018

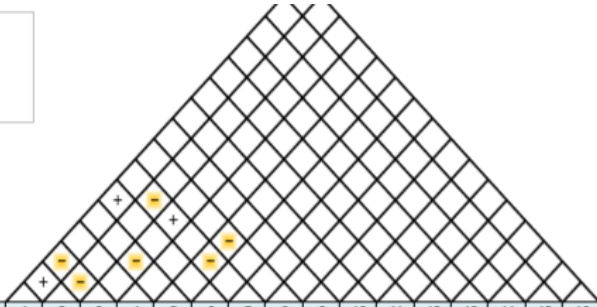

Row #	WHO: Customers						WHAT: Customer Requirements (Needs/Wants)	HOW MUCH: Target Values																NOW: Curr. Products				
	Weight Chart	Relative Weight	Small Irrigation Users	Garden Supply	Florists	Hobby Farmers		Maximum Relationship	10 Gallons	5 PSI	Zero Leakage	15 Minutes	\$100	4 Cubic Feet	270 lbf	Survives 5 foot Drop	Our Current Product	Automated System	Direct Spigot Hookup	Sprinklers	Hand Watering	Row #						
1	14%	9	9	9	9	9	Hold Water	●	○	●	▽	▽	●	●	▽	8	8	1	1	1	1	1						
2	14%	9	9	9	9	9	Airtight	▽	●	●	○	○	▽	●	○	7	6	5	5	8	2	2						
3	14%	9	9	9	9	9	Supply Water	▽	●	○	▽	○	▽	▽	▽	8	9	8	6	5	3	3						
4	8%	5	7	4	4	9	Modular/Adjustable	▽	▽	○	●	○	○	▽	○	7	9	7	3	9	4	4						
5	10%	8	5	6	7	9	Easy Assembly/Disassembly	▽	▽	▽	●	○	○	▽	▽	7	6	8	5	9	5	5						
6	9%	6	8	5	5	9	Polished/Refined	○	○	○	○	●	▽	○	○	7	9	6	5	4	6	6						
7	11%	6	8	7	6	9	Cheap	▽	○	○	▽	●	○	○	○	8	4	9	6	9	7	7						
8	9%	7	4	6	7	9	Durable	▽	○	●	○	●	○	●	●	9	7	8	6	9	8	8						
9	11%	8	6	5	8	9	Easy Maintenance/Service	▽	▽	○	●	○	▽	○	○	8	8	9	5	7	9	9						
10	0%																					10						
11	0%																						11					
12	0%																						12					
13	0%																						13					
14	0%																						14					
15	0%																						15					
16	0%																						16					

Curr. Products	HOW MUCH: Target Values							
	10 Gallons	5 PSI	Zero Leakage	15 Minutes	\$100	4 Cubic Feet	270 lbf	Survives 5 foot Drop
Max Relationship	9	9	9	9	9	9	9	9
Technical Importance Rating	231.4	412.2	305	393.1	447.7	288.5	461.3	279.7
Relative Weight	8%	14%	17%	13%	15%	10%	15%	9%
Our Current Product	5	5	4	5	5	5	4	3
Automated System	5	5	3	1	2	5	4	2
Direct Spigot Hookup	5	5	3	3	4	5	4	5
Sprinklers	5	5	1	1	2	5	2	5
Hand Watering	1	1	4	5	5	5	3	2
Column #	1	2	3	4	5	6	7	8

Appendix B – Preliminary Analysis

APPENDIX B

BUCKLING + WELD LOADS

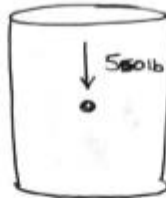

$$V = 65 \text{ GAL.}$$

$$F = 65 \cdot 8.34 \frac{\text{lb}}{\text{GAL}}$$

$$= \boxed{550 \text{ lb}}$$

FOR BUCKLING... ASSUME EACH SUPPORT LEG SEES $\frac{1}{4}$ OF THE TOTAL LOAD.

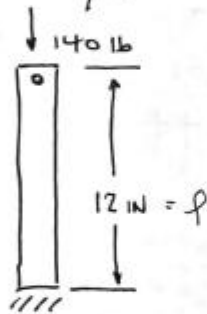

USE EULER COLUMN BUCKLING FORMULA...

$$C = 1.2 \text{ FIXED-ROUNDED (WELDS)}$$

$$K = .579 \text{ IN}^3 \text{ RADIUS OF GYRATION}$$

$$A = .470 \text{ IN}^2 \text{ AREA OF TUBE WALL}$$

$$E = 29 \times 10^6 \text{ psi STEEL}$$

$$P_{CR} = \frac{C \pi^2 EA}{(l/k)^2}$$

$$P_{CR} = \frac{(1.2) \pi^2 (29 \times 10^6 \text{ lbf/in}^2) (.470 \text{ in}^2)}{(12 \text{ in} / .579)^2}$$

$$P_{CR} = 375812 \text{ lbf}$$

WELD LOADS ON CROSS MEMBERS

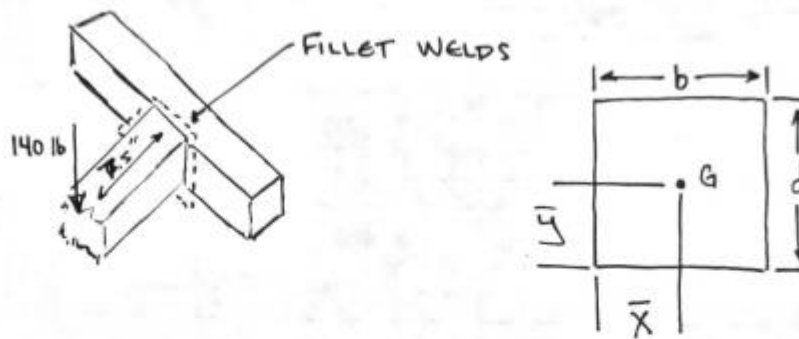

DIMENSIONS:

$$\begin{aligned} b &= 1.5'' \\ d &= 1.5'' \\ \bar{y} &= .75'' \\ \bar{x} &= .75'' \end{aligned}$$

$$\begin{aligned} A &= 1.414(b+d)h = 1.59 \text{ in}^2 \\ I_u &= \frac{d^3}{6}(3b+d) = 2.25 \text{ in}^3 \\ I &= .707hI_u = 0.597 \text{ in}^4 \end{aligned}$$

PRIMARY SHEAR:

$$\tau' = \frac{F}{A} = \frac{140 \text{ lb}}{1.414(1.5+1.5)(.375) \text{ in}^2}$$

$$\tau' = 88 \text{ psi}$$

SECONDARY SHEAR:

$$\tau'' = \frac{Mr}{I} = \frac{(140 \text{ lb})(8.5'')(0.75'')}{0.597 \text{ in}^4}$$

$$\tau'' = 1494 \text{ psi}$$

TOTAL SHEAR:

$$\tau = (88^2 + 1494^2)^{1/2} = 1497 \text{ psi}$$

$$\eta = \frac{S_{xy}}{\tau} = \frac{0.577(50000) \text{ psi}}{1497 \text{ psi}} = \boxed{19.3}$$

TIPPING LOAD OF DRUM / STAND

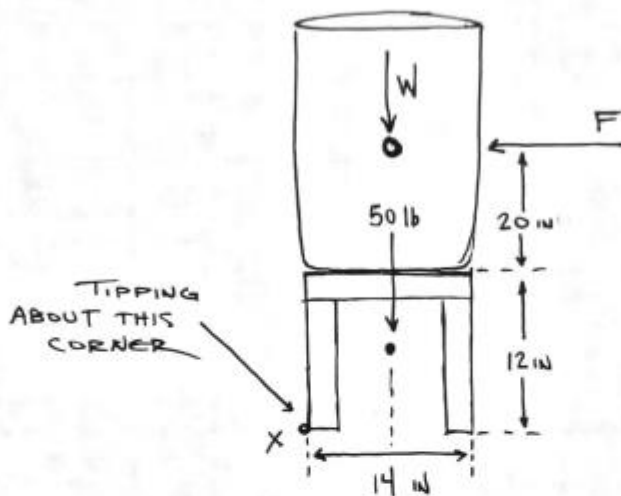

$$\sum M @ X = 0 :$$

$$(50 + W)(7 \text{ in}) - F(32 \text{ in}) = 0$$

$$F = (50 + W) \cdot \frac{7}{32}$$

BUCKET WEIGHTS (W)

$$100\% \text{ FULL} = 550 \text{ lb}$$

$$50\% \text{ FULL} = 275 \text{ lb}$$

$$25\% \text{ FULL} = 140 \text{ lb}$$

REQUIRED FORCE:

F (lb)	% FULL
131	100
82	50
41.7	25
10.9	0

Appendix C – Design Hazards Checklist

DESIGN HAZARD CHECKLIST

Team: GRAVITY DRIP Advisor: 2/1/19 Date: _____

- | Y | N | |
|-------------------------------------|-------------------------------------|--|
| <input type="checkbox"/> | <input checked="" type="checkbox"/> | 1. Will the system include hazardous revolving, running, rolling, or mixing actions? |
| <input type="checkbox"/> | <input checked="" type="checkbox"/> | 2. Will the system include hazardous reciprocating, shearing, punching, pressing, squeezing, drawing, or cutting actions? |
| <input type="checkbox"/> | <input checked="" type="checkbox"/> | 3. Will any part of the design undergo high accelerations/decelerations? |
| <input type="checkbox"/> | <input checked="" type="checkbox"/> | 4. Will the system have any large (>5 kg) moving masses or large (>250 N) forces? |
| <input type="checkbox"/> | <input checked="" type="checkbox"/> | 5. Could the system produce a projectile? |
| <input checked="" type="checkbox"/> | <input type="checkbox"/> | 6. Could the system fall (due to gravity), creating injury? |
| <input type="checkbox"/> | <input checked="" type="checkbox"/> | 7. Will a user be exposed to overhanging weights as part of the design? |
| <input type="checkbox"/> | <input checked="" type="checkbox"/> | 8. Will the system have any burrs, sharp edges, shear points, or pinch points? |
| <input type="checkbox"/> | <input checked="" type="checkbox"/> | 9. Will any part of the electrical systems not be grounded? |
| <input type="checkbox"/> | <input checked="" type="checkbox"/> | 10. Will there be any large batteries (over 30 V)? |
| <input type="checkbox"/> | <input checked="" type="checkbox"/> | 11. Will there be any exposed electrical connections in the system (over 40 V)? |
| <input type="checkbox"/> | <input checked="" type="checkbox"/> | 12. Will there be any stored energy in the system such as flywheels, hanging weights or pressurized fluids/gases? |
| <input type="checkbox"/> | <input checked="" type="checkbox"/> | 13. Will there be any explosive or flammable liquids, gases, or small particle fuel as part of the system? |
| <input type="checkbox"/> | <input checked="" type="checkbox"/> | 14. Will the user be required to exert any abnormal effort or experience any abnormal physical posture during the use of the design? |
| <input type="checkbox"/> | <input checked="" type="checkbox"/> | 15. Will there be any materials known to be hazardous to humans involved in either the design or its manufacturing? |
| <input type="checkbox"/> | <input checked="" type="checkbox"/> | 16. Could the system generate high levels (>90 dBA) of noise? |
| <input checked="" type="checkbox"/> | <input type="checkbox"/> | 17. Will the device/system be exposed to extreme environmental conditions such as fog, humidity, or cold/high temperatures, during normal use? |
| <input type="checkbox"/> | <input checked="" type="checkbox"/> | 18. Is it possible for the system to be used in an unsafe manner? |
| <input type="checkbox"/> | <input checked="" type="checkbox"/> | 19. For powered systems, is there an emergency stop button? |
| <input type="checkbox"/> | <input checked="" type="checkbox"/> | 20. Will there be any other potential hazards not listed above? If yes, please explain on reverse. |

For any "Y" responses, add (1) a complete description, (2) a list of corrective actions to be taken, and (3) date to be completed on the reverse side.

Description of Hazard	Planned Corrective Action	Planned Date	Actual Date
6. THE TANK IS ELEVATED ABOVE THE GROUND AND IS HEAVY ENOUGH TO CAUSE INJURY IF TIPPED	EXTENSIVE TESTING OF CASE TO ENSURE TIPPING FORCES FALL WITHIN A SAFE RANGE		
17. THE SYSTEM WILL SPEND THE MAJORITY OF ITS LIFE OUTDOORS AND UNCOVERED.	TREATING OF ALL MATERIALS IN ORDER TO PREVENT CORROSION AND RUSTING.		

Appendix D – FMEA

System / Function	Potential Failure Mode	Potential Effects of the Failure Mode	Severity	Potential Causes of the Failure Mode	Current Preventative Activities	Occurrence	Current Detection Activities	Detection	Priority	Recommended Action(s)
Base support / elevate tank	Stand breaks	System Collapses, Injury to user occurs. Damage to property	9	1) Legs Buckle 2) Welds fail	1) Load analysis 2) Weld Analysis	2	Stress Testing	2	36	None needed
Arm Support / Secure Bucket	Arms lock	a) Arms lock in current position b) New tanks can no longer be inserted.	3	1) Warping of tubing 2) Debris between tubing	1) Treatment of metal.	4	Observation	2	24	Fixturing of tubing when welding to prevent warping.
Piping System / Water Delivery	Leaks in Piping	a) Loss of water to hoses b) Loss of pressure to hoses	6	1) Pipe threads not sealing 2) adapters not sealing 3) manifold not sealing	1) Flow analysis	4	Leak Testing	1	24	Use of high tolerances threads.

Appendix E – Expanded Bill of Materials

No.	Subassembly	Quantity	Cost	Purchaser
Stand				
1	1.5"x1.5"x0.083" Mild Steel Square Tubing	8 ft	\$23.20	Plaskett
Locking Mechanism				
2	3/8" Square Nut	4	\$0.92	Plaskett
Base				
3	3/16"x1" Mild Steel Bar Stock	6 ft	\$13.52	Plaskett
Arms				
4	1.25"x1.25"x0.065 Mild Steel Square Tubing	4 ft	\$10.61	Plaskett
Manifold				
5	2"x2"x0.250" Mild Steel Square Tubing	5 ft	\$58.60	Plaskett
Piping				
6	1"x1" Brass Barb x MPT Adapter	1	\$6.48	Waldron
7	PolyCarbonate Tubing	2	\$5.98	Presson
8	Garden Hose Adapter	3	\$14.79	Waldron
9	Banjo HB100 Hose Fitting, Adapter, 1" NPT Male x 1"	1	\$5.29	Presson
10	Banjo TF100 Bulkhead Tank Fitting, 1" NPT Female	1	\$9.79	Presson
11	1-3/4 in Stainless-Steel Clamp	2	\$3.98	Presson
12	Expo Supplies	NA	\$11.21	Waldron
Total			\$164.37	

Appendix F – Links to Sourced Product Literature

Steel Tubing

<http://www.prwsteel.com/wp-content/uploads/2016/06/prwsteelcatalog.pdf> , pg. 38

Steel Bar Stock

<http://www.prwsteel.com/wp-content/uploads/2016/06/prwsteelcatalog.pdf> , pg. 18

Star Knob

<https://www.amazon.com/8x16-Thru-Hole-Star-Knob/dp/B000UH31KO>

1"x1" Brass Barb x MPT Adapter

<https://www.homedepot.com/p/Apollo-1-in-x-1-in-Brass-Barb-x-MPT-Adapter-POLYBIM1/203041864>

Polycarbonate Tubing

<https://www.usplastic.com/catalog/item.aspx?itemid=23791>

Garden Hose Adapter

<https://www.homedepot.com/p/Everbilt-Lead-Free-Brass-Garden-Hose-Adapter-3-4-in-MGH-x-3-4-in-MIP-x-Tapped-1-2-in-FIP-801709/300095988>

1" NPT x 1" Hose ID Black HDPE Adapter

<https://www.usplastic.com/catalog/item.aspx?itemid=27809&catid=>

1" Polypropylene Bulkhead Tank Fitting 2-1/4"

<https://www.usplastic.com/catalog/item.aspx?itemid=65992>

1-3/4 in Stainless-Steel Clamp

<https://www.homedepot.com/p/Everbilt-1-3-4-in-Stainless-Steel-Clamp-6720595/202309386?keyword=202309386&semanticToken=200300000+%3E++st%3A%7B202309386%7D%3Ast+cn%3A%7B0%3A0%7D+cnb%3A%7B9%3A0%7D+oos%3A%7B0%3A1%7D+qu%3A%7B202309386%7D%3Aqu>

Appendix G – Drawing Package

ITEM NO.	PART NUMBER	DESCRIPTION	QTY.
1	Frame Base	1.5" X 1.5" X .083" Mild Steel Tubing	1
2	Support Arm	1.25" X 1.25" X .065" Mild Steel Tubing W/ Welded .25" Stock	4
3	0.5 BSP Stainless Steel Hose Tail RS-499-3754	Stock Component; 3/4" MPT to 3/4" GHT Hose Adapter	3
4	Manifold	1.5" X 1.5" X .25" Mild Steel Tubing W/ Welded Caps & 3/4" Holes	1
5	Brass Barbed Adapter	ADAPTER; BRASS; 3/4 BARB X 3/4 MPT	1
6	Bulkhead Fitting	2" HDPE Bulkhead Fitting	1
7	HDPE Barbed Adapter	ADAPTER; HDPE; 3/4 BARB X 3/4 MPT	1
8	Tubing	1' Section of 1" ID Polyethylene Tubing	1
9	Manifold Plate	6.5" X 12" X 3/16" Mild Steel Stock	1

Cal Poly Mechanical Engineering ME 429 - Winter '19	Lab Section:	Assignment #	Title: Grav Drip Exploded Assembly	Drwn. By: Ryan Waldron	
	Dwg. #:	Nxt Asb:	Date: 2/7/19	Scale: 1:9	Chkd. By:

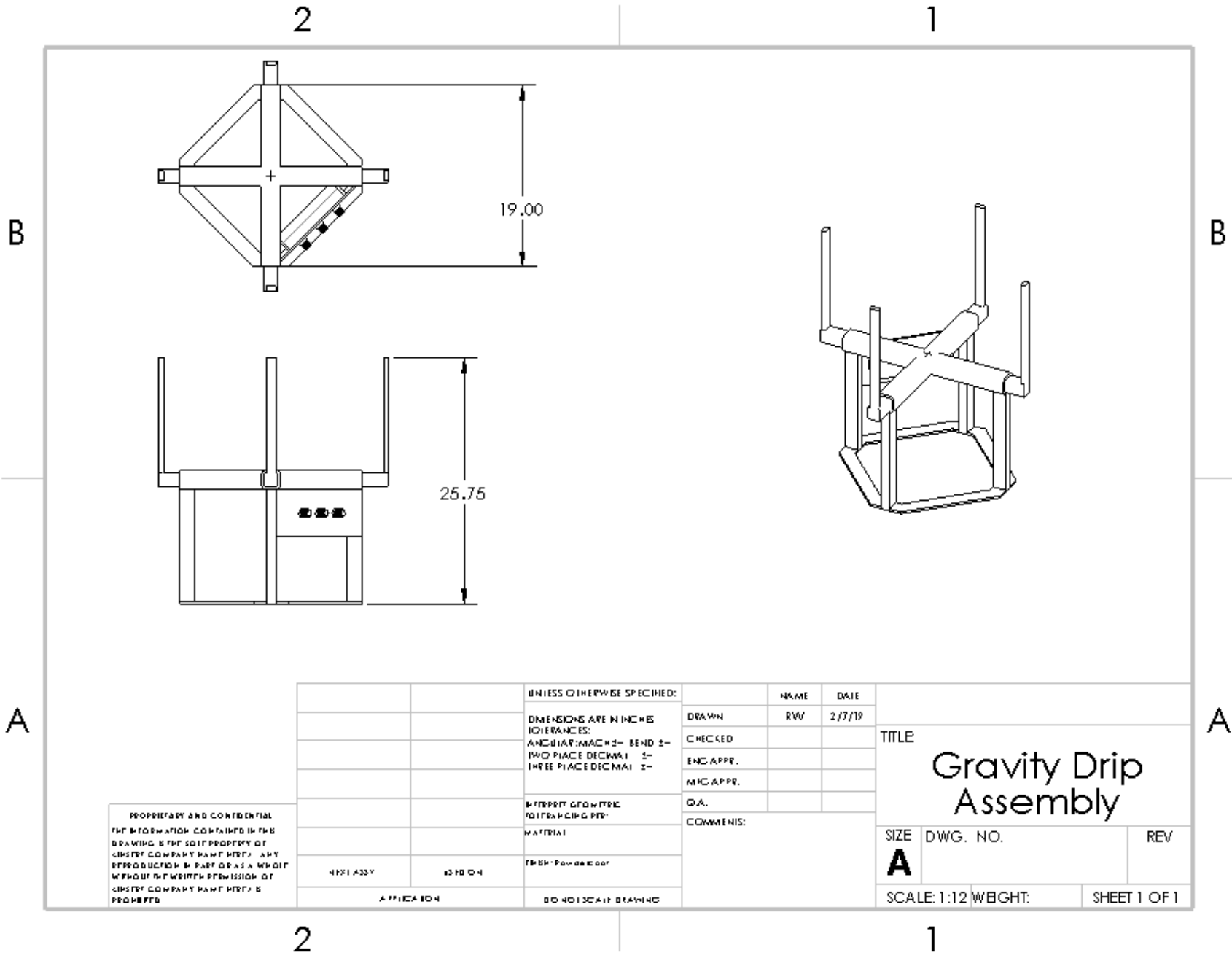

PROPRIETARY AND CONFIDENTIAL
 THE INFORMATION CONTAINED IN THIS
 DRAWING IS THE SOLE PROPERTY OF
 GINSEY COMPANY NAME HERE. ANY
 REPRODUCTION IN PART OR AS A WHOLE
 WITHOUT THE WRITTEN PERMISSION OF
 GINSEY COMPANY NAME HERE IS
 PROHIBITED.

		UNLESS OTHERWISE SPECIFIED:		NAME	DATE
		DIMENSIONS ARE IN INCHES	DRAWN	RW	2/7/19
		TOLERANCES:	CHECKED		
		ANGULAR: MACH— BEND ±—	ENG APP.		
		TWO PLACE DECIMAL ±—	MTC APP.		
		THREE PLACE DECIMAL ±—	Q.A.		
		FINISH: DRAWING	COMMENTS:		
		MATERIAL			
		FINISH: Powder Coat			
NEXT ASSY	ASSEMBLY	DO NOT SCALE DRAWING			

TITLE		
Gravity Drip Assembly		
SIZE	DWG. NO.	REV
A		
SCALE: 1:12 WEIGHT:		SHEET 1 OF 1

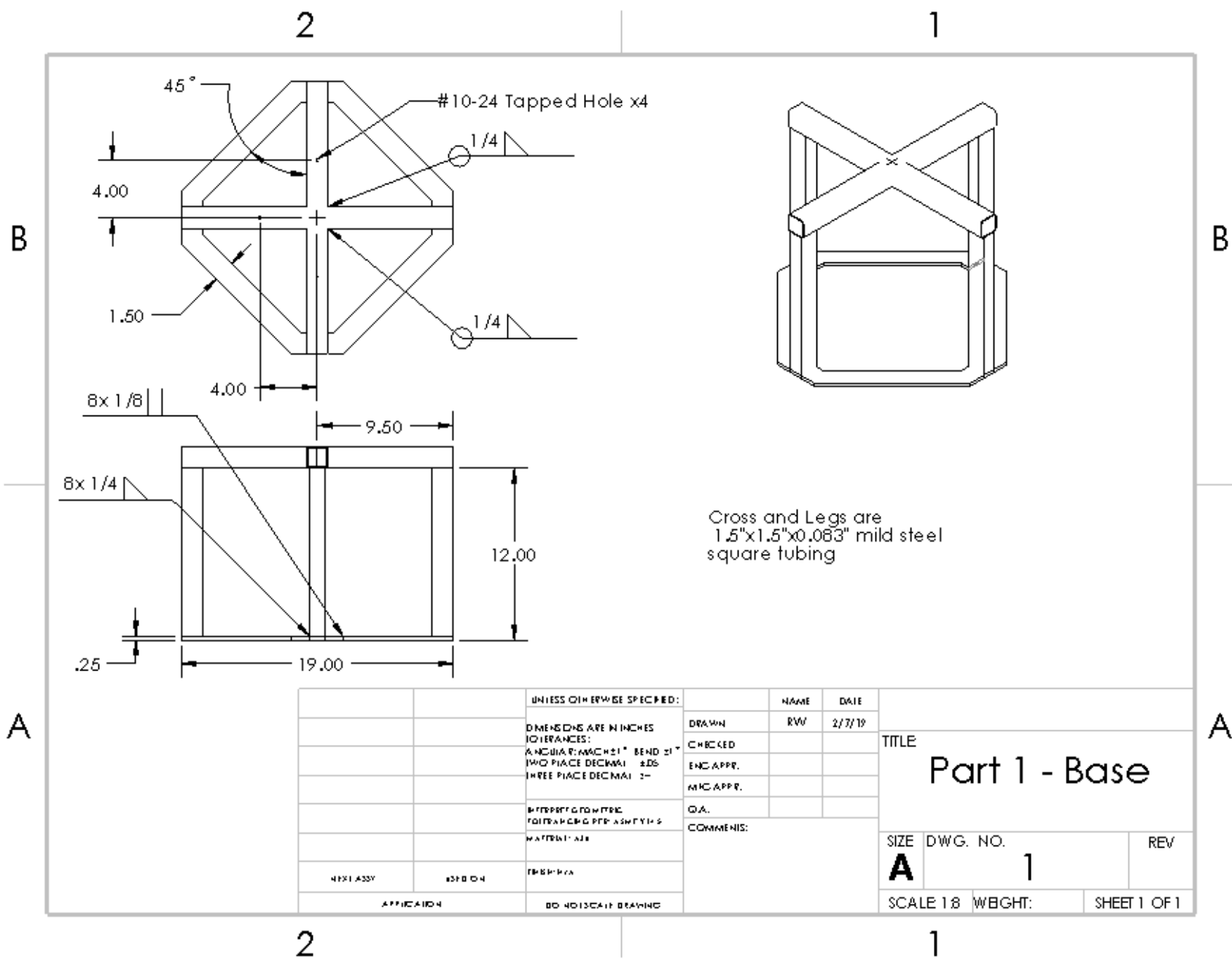

Cross and Legs are
1.5"x1.5"x0.083" mild steel
square tubing

		UNLESS OTHERWISE SPECIFIED:		NAME	DATE
		DIMENSIONS ARE IN INCHES		DRAWN	RW
		TOLERANCES:			2/7/19
		FRACTIONS: FRACTIONS		CHECKED	
		DECIMALS: TWO PLACE DECIMALS		ENG. APPR.	
		THREE PLACE DECIMALS		MIC. APPR.	
		FIT: FREE FIT		Q.A.	
		FINISH: AS SHOWN		COMMENTS:	
NEXT ASSY	BY	DATE			
APPLICATION					

TITLE		
Part 1 - Base		
SIZE	DWG. NO.	REV
A	1	
SCALE 1:8	WEIGHT:	SHEET 1 OF 1

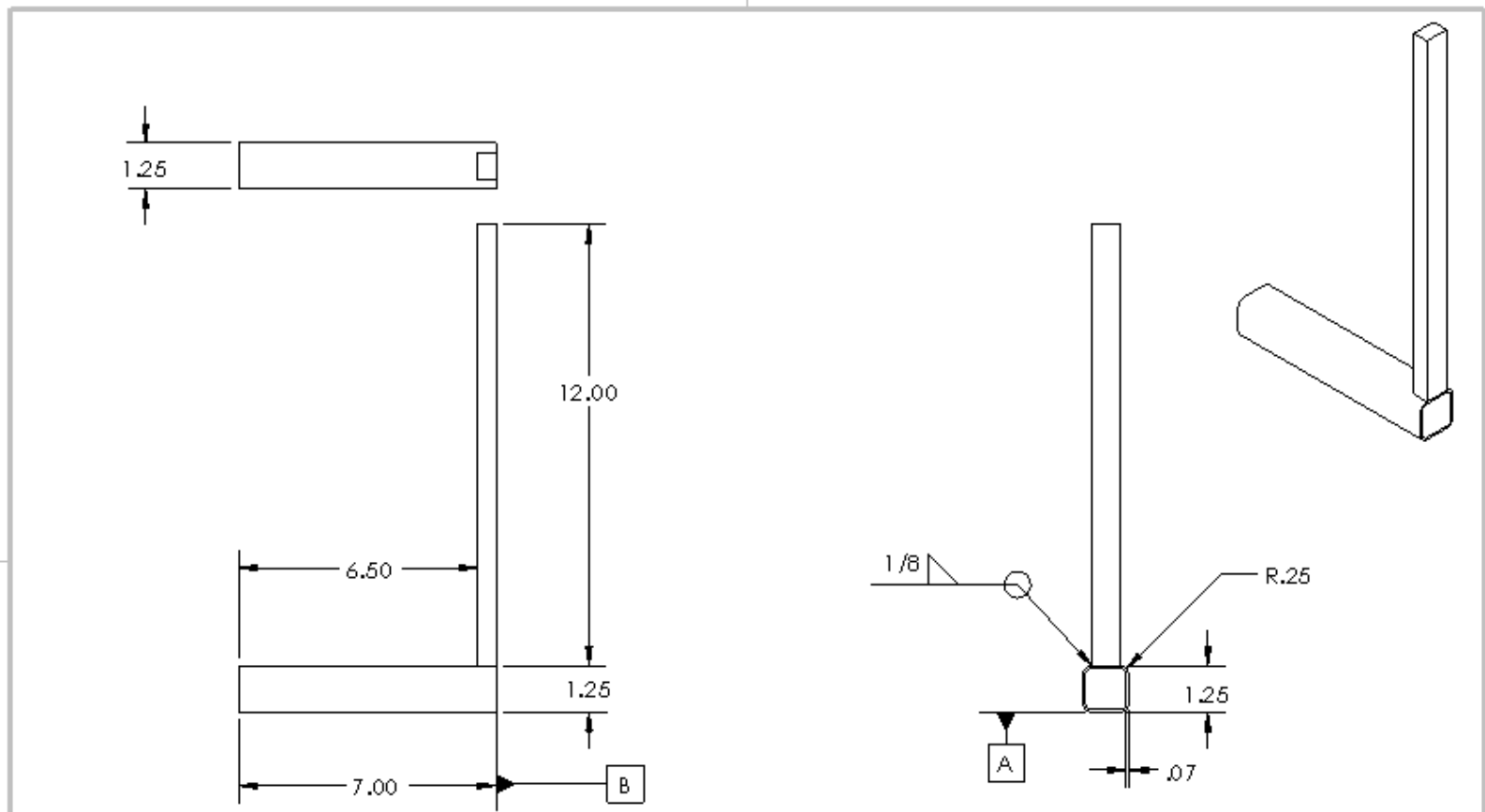

PROPRIETARY AND CONFIDENTIAL
 THE INFORMATION CONTAINED IN THIS
 DRAWING IS THE SOLE PROPERTY OF
 CINCINNATI COMPANY PART NUMBER ANY
 REPRODUCTION IN PART OR AS A WHOLE
 WITHOUT THE WRITTEN PERMISSION OF
 CINCINNATI COMPANY PART NUMBER IS
 PROHIBITED

		UNLESS OTHERWISE SPECIFIED:	NAME	DATE
		DIMENSIONS ARE IN INCHES	DRAWN	RW
		TOLERANCES:	CHECKED	2/7/19
		ANGULAR: MACH $\pm 1^\circ$ BEND $\pm 1^\circ$	ENG APPR.	
		TWO PLACE DECIMAL $\pm .010$	MIC APPR.	
		THREE PLACE DECIMAL $\pm .005$	Q.A.	
		MATERIALS	COMMENTS:	
		FINISH		
NEXT ASSY	ASSEMBLY	DO NOT SCALE DRAWING		

TITLE:		
Part 2 - Support Arm		
SIZE	DWG. NO.	REV
A	2	
SCALE: 1:4	WEIGHT:	SHEET 1 OF 1

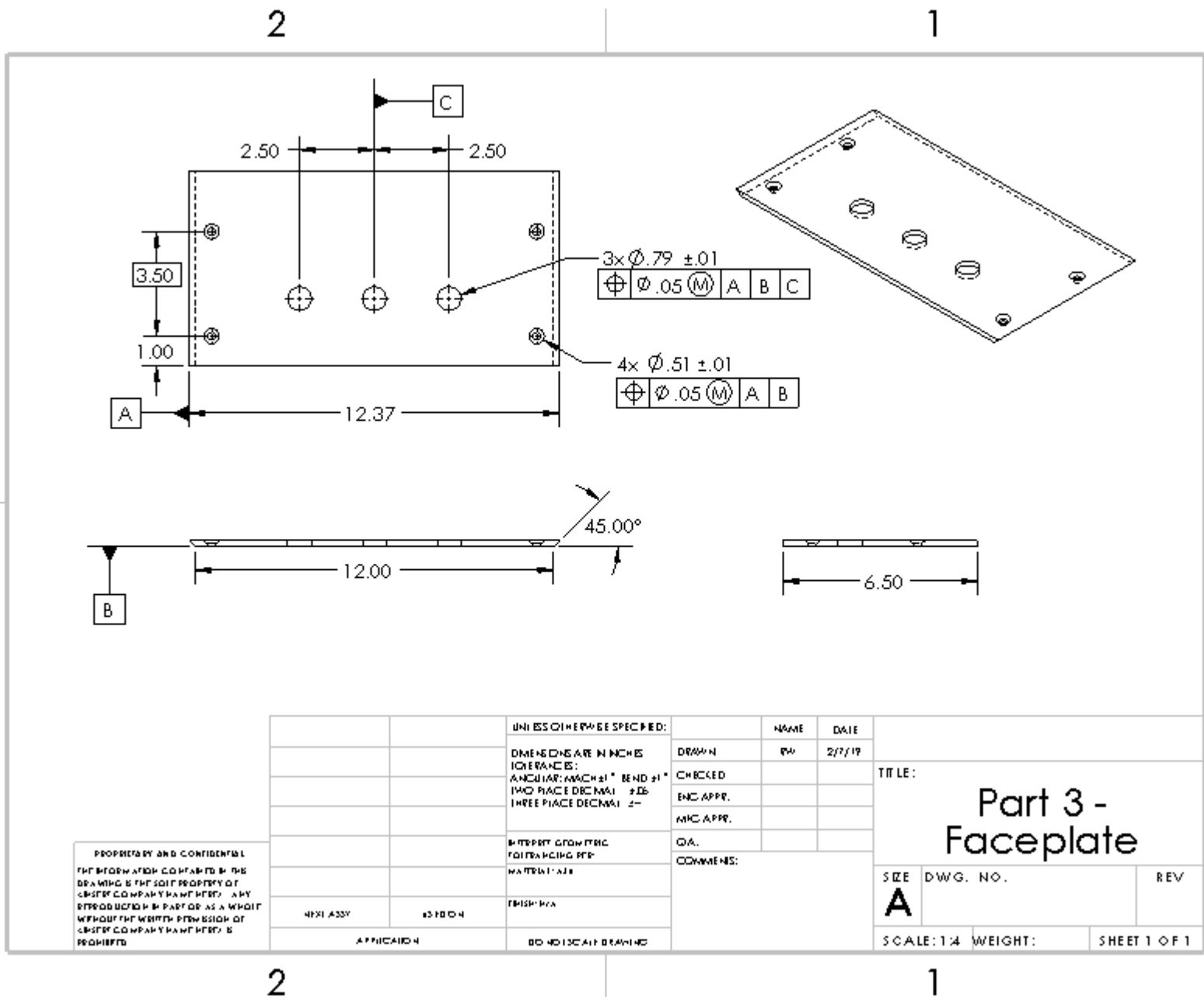

PROPRIETARY AND CONFIDENTIAL
 THE INFORMATION CONTAINED IN THIS
 DRAWING IS THE SOLE PROPERTY OF
 CUMMINS COMPANY LIMITED. ANY
 REPRODUCTION IN PART OR AS A WHOLE
 WITHOUT THE WRITTEN PERMISSION OF
 CUMMINS COMPANY LIMITED IS
 PROHIBITED.

		UNLESS OTHERWISE SPECIFIED:	NAME	DATE		
		DIMENSIONS ARE IN INCHES	DRAWN	RW	2/7/19	TITLE: Part 3 - Faceplate
		TOLERANCES:	CHECKED			
		ANGULAR: $\pm 0.0001^\circ$ BEND $\pm 1^\circ$	ENG APPR.			
		FINO: FFACE DECIMAL ± 0.05	MFG APPR.			
		THREE PLACE DECIMAL ± 0.001	QA.			SIZE A
		PROPERTY GROUPING FOR MARKING REF.	COMMENTS:			DWG. NO.
		MATERIAL: ALU				REV
NEXT ASSY	ASSEMBLY	FINISH: PA				
APPROVALS		DO NOT SCALE DRAWING			SCALE: 1:1	WEIGHT:
					SHEET 1 OF 1	

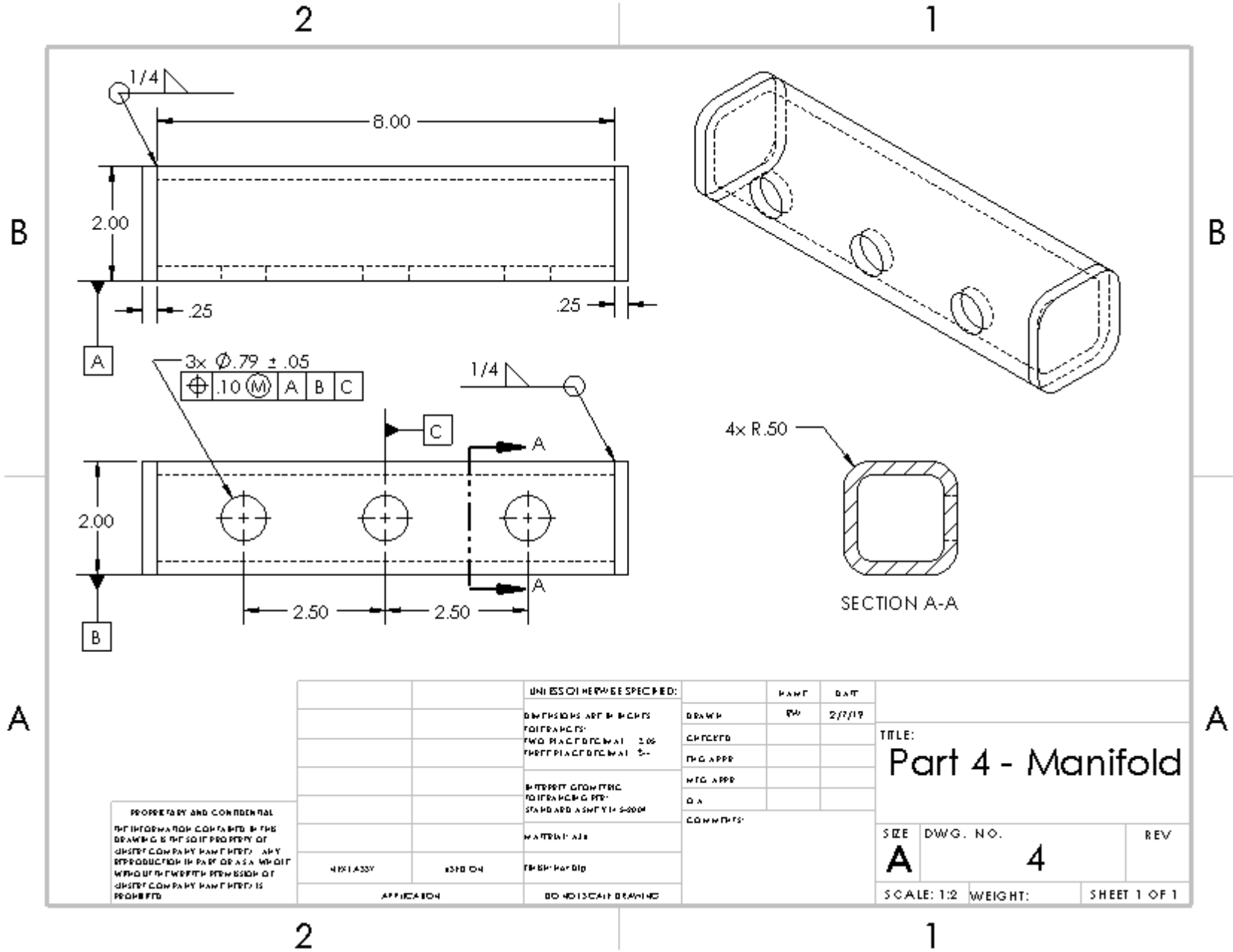

PROPERTY AND CONFIDENTIAL
 THE INFORMATION CONTAINED IN THIS DRAWING IS THE SOLE PROPERTY OF JENSEN COMPANY PART HEREOF. ANY REPRODUCTION IN PART OR AS A WHOLE WITHOUT THE WRITTEN PERMISSION OF JENSEN COMPANY PART HEREOF IS PROHIBITED.

		UNLESS OTHERWISE SPECIFIED:		PART	DATE
		DIMENSIONS ARE IN INCHES	DRAWN	RW	2/7/19
		TOLERANCES:	CHECKED		
		FRACTIONS: FIVE PLACE DECIMAL	ENG APPR		
		DECIMALS: TWO PLACE DECIMAL	MFG APPR		
		ANGLES: AS SHOWN	D.A.		
		FINISH: AS SHOWN	COMMENTS:		
NEXT ASSY	ASSEMBLY	MATERIAL			
		FINISH: HARD DIP			
	APPLICATION	DO NOT SCALE DRAWING			

TITLE:
Part 4 - Manifold

SIZE	DWG. NO.	REV
A	4	
SCALE: 1:2	WEIGHT:	SHEET 1 OF 1

Appendix H – Test Plans

Item 1: Minimum Deflection Under Load

Description of Test:

Load stand with fully loaded barrel. Inspect legs and all welds. Measure deflection at center of cross frame.

Minimum Acceptance Criteria:

No measurable deflection and no cracks present in welds.

Required Materials:

1. 55-Gallon Barrel
2. Water Source
3. Scrap Wood
4. Dial Gauge
5. Level Surface

Testing Protocol:

1. Place stand on level ground with inserted 55-gallon barrel.
2. Stack scrap wood underneath frame until a dial gauge can be fitted in between wood and bottom of the cross frame.
3. Zero dial gauge at current cross frame location.
4. Completely fill barrel
5. Check gauge for any deflection
6. Inspect welds for any cracks.

Data:

Deflection:	0.01 inches
Welds:	P/F

PASS / FAIL

Item 2: Tipping Test

Description of Test:

Load stand with full barrel. Pull barrel till tipping occurs and measure required tipping force.

Minimum Acceptance Criteria:

At least 70 lbs of lateral force before tipping.

Required Materials:

1. 55-Gallon Barrel
2. Water Source
3. Rope
4. Spring and hook scale
5. Level Surface

Testing Protocol:

1. Place stand on level ground.
2. Insert empty 55-gallon barrel.
3. Completely fill barrel.
4. Attach hook scale midway up support arms (6 inches above cross frame).
5. Tie rope to the other end of the hook scale.
6. Slowly pull barrel with rope with gradually increasing force.
7. Record Force required to start tipping.
8. Repeat test 10 times for accuracy

Data:

Trial	1	2	3
Force [lbf]	110 (CM)	125 (CM-8in)	70 (CM+12in)
Average [lbf]	101.6		

PASS / FAIL

Item 3: Weight and Size

Description of Test:

Measurement of system dimensions and weight.

Minimum Acceptance Criteria:

50 lbs and 2' by 2' with 3' height. (Without Barrel)

Required Materials:

1. Scale
2. Tape Measure

Testing Protocol:

1. Weigh all components individually before assembly with scale.
2. Sum weights of all components to find total system weight.
3. Measure dimensions (total height, distance across support arms) with tape measure.

Data:

Weight [lbs]	20.3
Height [in]	25.5
Width [in]	14.5
Length [in]	14.5

PASS / FAIL

Item 4: Leak Test

Description of Test:

Let barrel drain from completely full to empty. Check for any leak points and catch any leaking water for measurement.

Minimum Acceptance Criteria:

No visible leakage. 0 ml of lost water during full barrel drain.

Required Materials:

1. 55-Gallon Barrel
2. Water Source
3. Graduated Receptacles (to catch water)

Testing Protocol:

1. Completely fill 55-Gallon Drum.
2. Place receptacles underneath potential leak points
3. Open valves to let system drain out hose ends.
4. Initially check for any obvious leak points.
5. After full drain, check receptacles for any caught leakage.

Data:

Water leakage [mL]	None
--------------------	------

PASS / FAIL

Item 5: Pressure Supplied

Description of Test:

Measure pressure supplied to the secondary lines located on the ground.

Minimum Acceptance Criteria:

At least 1 psi supplied to lines.

Required Materials:

1. 55-Gallon barrel
2. Water Source
3. 0.5" hose
4. 0.5" threaded pressure gauge

Testing Protocol:

1. Completely fill 55-Gallon barrel.
2. Connect hose to outlet manifold and connect pressure gauge to hose.
3. Begin tank drain through other two outlets.
4. Record pressure at various points throughout drain.

Data:

Pressure [psi]	1.1
----------------	-----

PASS / FAIL

Item 6: Assembly Time

Description of Test:

Record average time of assembly by typical user.

Minimum Acceptance Criteria:

Less than 10 mins.

Required Materials:

1. Unassembled Gravity Drip System
2. User Manual
3. Stop Watch
4. Three Volunteers

Testing Protocol:

1. Hand volunteer user manual and components.
2. Begin stop watch.
3. Observe volunteer to check for any aspects of the assembly they struggle with.
4. Record time to complete.
5. Ask for user feedback on the assembly process or user manual.

Data:

Volunteer #	1	2	3
Time [mins]	3.0	2.2	2.4
Avg [mins]	2.5		

PASS / FAIL

Appendix I - Design Verification and Report

Senior Project DVP&R													
Date: 2/6/19		Team: Grav Drip		Sponsor: Tina Creel			Description of System: Gravity Drip Irrigation System				DVP&R Engineer: Cole Presson Ryan Waldron Josh Plaskett		
TEST PLAN								TEST REPORT					
Item No	Specification #	Test Description	Acceptance Criteria	Test Responsibility	Test Stage	SAMPLES		TIMING		TEST RESULTS			NOTES
						Quantity	Type	Start date	Finish date	Test Result	Quantity Pass	Quantity Fail	
1	2	Measure deflection under 550 lb load and inspect all welds.	<0.05 in No weld cracks	J. Plaskett	SP	1	SUB	4/2/2019	4/9/2019	0.01 in No cracks	Pass		
2	9	Force required to tip bucket at center of mass.	>70 lbf	R. Waldron	SP	1	SYS	4/16/2019	4/23/2019	110 lbf	Pass		70 lbf at CM+12 in 125 lbf at CM - 8in
3	6	Weight of System	<40 lb	C. Presson	SP	1	SYS	4/2/2019	4/2/2019	20.3 lb	Pass		
4	3>5	System Dimensions	2 ft W x 2 ft L x 3 ft H	C. Presson	SP	1	SYS	4/9/2019	4/9/2019	25.5 in H 14.5 in W 14.5 in L	Pass		
5	7	Leak Test Through Piping System	0 mL	J. Plaskett	SP	1	SUB	4/16/2019	4/23/2019	No Leak	Pass		
6	1	Pressure Supplied To Main Lines	>1 psi	R. Waldron	SP	1	SYS	4/16/2019	4/23/2019	1.1 psi	Pass		
7	8	Assembly Time of System	<10 mins	C. Presson	FP	1	SYS	4/30/2019	5/7/2019	2.5 mins	Pass		
8													
9													
10													

Appendix J - Gantt Chart

Final Manufacturing/Testing Timeline Gantt Chart

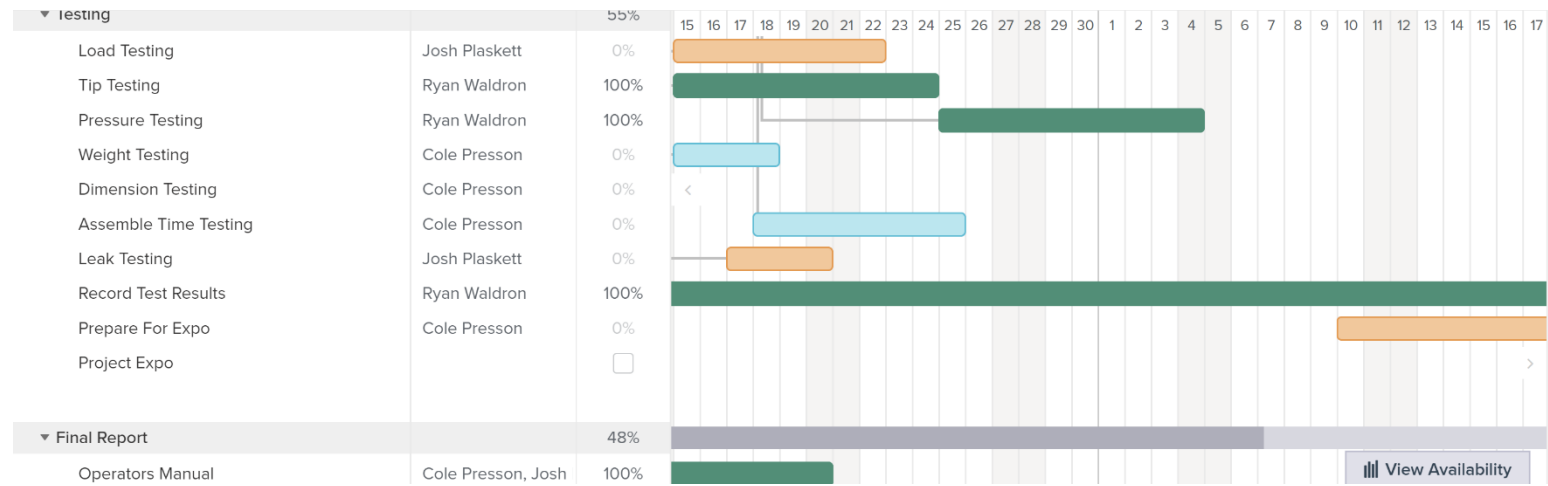
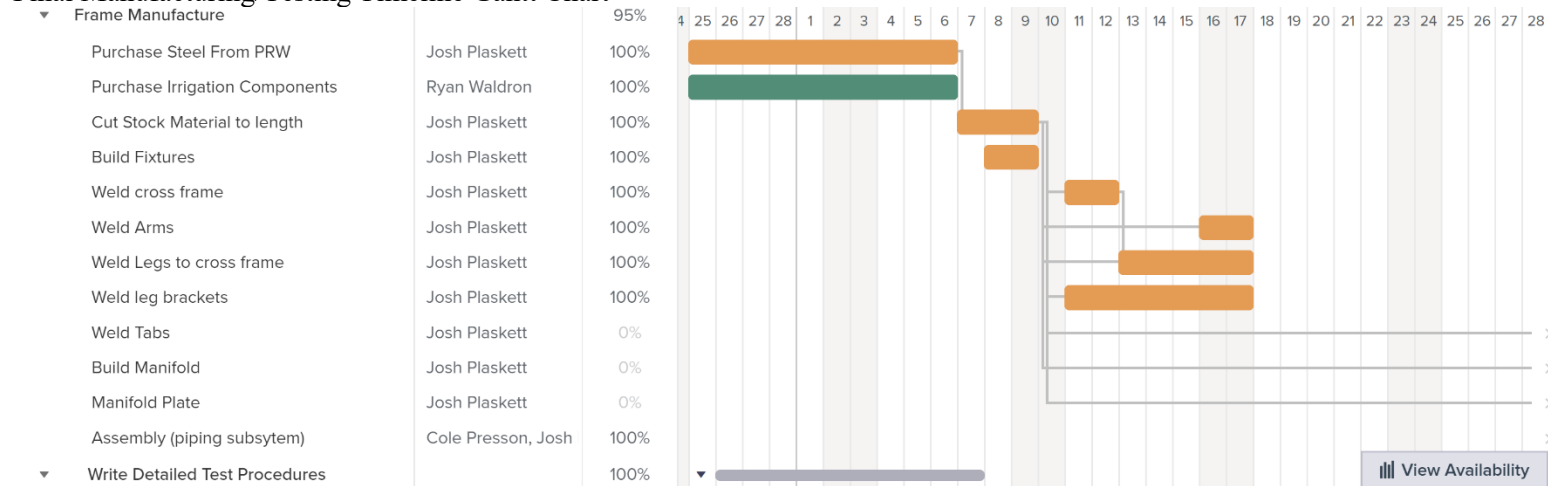

Gravity Drip User Manual

Important: This product is meant for use as an irrigation tool only.

This user's manual includes instructions for product use and important safety information. Read this section entirely including all safety warnings and cautions before using the product

Assembly – The following section will walk through the steps necessary to construct the gravity drip irrigation system.

Frame Assembly

1. The first step when constructing the gravity drip irrigation system is assembling the frame. To do this, the support arms must first be inserted into the cross frame.
2. Next, the hex bolts must be inserted into the nuts on the underside of the cross frame. The hex bolts will be tightened after the empty barrel is loaded onto the frame.

Note: The Gravity Drip irrigation system supports standard drum barrels ranging from the 30 to 55 gallon sizes.

Barrel Assembly

1. Drill through the bottom of a chosen barrel with a 2 inch hole saw.
2. Insert the empty barrel into the frame assembly.

Piping System Assembly

1. Before the piping system is assembled, the assembled barrel must be loaded onto the cross frame and secured with the support arms. The outlet fitting on the bottom of the barrel must be aligned with one of the four open areas of the frame, allowing the barrel to sit flush with the frame. Tighten the hex bolts to lock the support arms and the barrel in place.
2. Insert the inlet fitting into the manifold.
3. Attach the (1") outlet hose to the barrel outlet fitting and secure with a hose clamp. Attach the other end to the inlet fitting of the manifold and secure with a hose clamp.
4. Align the faceplate with the mounting tabs on the frame and secure with hex bolts.
5. Align the three manifold holes with the holes of the faceplate. Insert the (¾") outlet fittings through the faceplate and thread into the manifold. Start to thread all three outlet fittings into the manifold before tightening fully.

Frame Safety

1. Ensure that the frame rests on a flat surface (<2° Slope) to prevent the frame assembly from tipping under load.
2. Ensure that at least 2 inches of each telescoping arm are engaged inside of the base frame tubing. There are '2 inch' markings are denoted on each arm by a strip of red tape, noting the maximum length of the arm.
3. Make sure all arms are set to the same position to prevent the bucket from being loaded off-center of the frame.

WARNING When adjusting the support arms, take caution to keep fingers clear of pinch points and remember to retighten the bolts after the adjustment is complete.

Filling the Barrel

1. Before filling the barrel, ensure that the flow valves are closed.
2. Fill the barrel with the desired volume of water.

WARNING The system will be extremely heavy when loaded with water. Do not push or jostle the bucket or frame.