

Human Sensing Expansion for a Rolling Robot

By

Eric Hanson

Advisor: Dr. Dennis Derickson

Senior Project

ELECTRICAL ENGINEERING DEPARTMENT

California Polytechnic State University

San Luis Obispo

June 2019

Table of Contents

List of Tables and Figures	4
Abstract	5
Chapter 1: Introduction	6
Chapter 2: Project Planning	7
Customer Needs Assessment	7
Requirements and Specifications	7
Functional Decomposition	8
Level 0 Block Diagram	8
Level 1 Block Diagram	9
Timeline	10
Cost Estimates	11
Chapter 3: Project Design	13
Thermopile Sensor	13
Primary Sensor: Adafruit AMG8833 Panasonic Grid-Eye Breakout	14
Secondary Sensors: Melexis MLX90614	15
Adafruit METRO 328 – (Arduino Uno Clone)	15
Chapter 4: Project Development	17
Communication between Arduinos	17
Sensor Prototype	17
Chapter 5: Testing and Design Verification	22
Test platform Design	22
Results	24
Final Cost of Materials	25
Future Improvements	26
Chapter 6: Conclusion	27
References	28
Appendix A: Building a BB-8 Droid from Star Wars	29
Build choices	29
Ball Design	29
Interior Drive Design	30
3D Printing	30

Acquiring Parts	31
3D Printing Parts	32
Build Process	35
Final Assembly	39
Further Work	42
BB-AZ	43
WonderCon Anaheim 2019:	44
Star Wars Celebration Chicago 2019:	44
Appendix C: Analysis of Senior Project Design	46
1. Summary of Functional Requirements	46
2. Primary Constraints	47
3. Economic	47
4. If Manufactured on a Commercial Basis:	47
5. Environmental	48
6. Manufacturability	48
7. Sustainability	48
8. Ethical	49
9. Health and Safety	49
10. Social and Political	50
11. Development	50

List of Tables and Figures

Table 1: Human Sensing Expansion for a Rolling Robot Requirements and Specifications	7
Table 2: Human Sensing Expansion for a Rolling Robot Deliverables	8
Table 3: Human Sensing Expansion for BB-8 Functionality	9
Table 4: IR Temperature sensors from Level 1 block diagram	10
Table 5: 64 Pixel IR temperature sensor from Level 1 block diagram	10
Table 6: Arduino Microcontroller from Level 1 block diagram	10
Table 7: Initial Cost Estimates	12
Table 8: Final Cost of Sensor Project	25
Table 9: Cost of Test Setup	25
Table 10: Results of Sensor Project compared to the Specifications	25

Figure 1: Level 0 Human Sensing Expansions for BB-8 functionality block diagram	8
Figure 2: Level 1 sensor expansion block diagram	9
Figure 3: Winter Quarter 2019 Estimated Timeline	11
Figure 4: Spring Quarter 2019 Estimated Timeline	12
Figure 5: Thermopile Voltage Diagram	13
Figure 6: Diagram of a Thermopile	14
Figure 7: Panasonic Grid-Eye Breakout from Adafruit	14
Figure 8: Melexis MLX90614	15
Figure 9: Adafruit METRO 328	15
Figure 10: Schematic of Connection Between Sensor and Dome Arduinos	17
Figure 11: Prototype Created for Sensor Testing	18
Figure 12: Field of View Diagram of Four Sensor Prototype	19
Figure 13: Final Sensor Field of View Diagram	20
Figure 14: Image of Sensor Placement in Dome	20
Figure 15: Sensors Wired in Dome	21
Figure 16: Schematic of Sensors	21
Figure 17: Bracket to Attach Dome to Servo	22
Figure 18: Image of Test Device Used	24
Figure 19: Image of Dome Being Tested	25

Abstract

For the past twenty years, fans of the Star Wars movies have been building their own replica robots or “droids” that they fell in love with on the big screen. This project takes an existing design for the BB-8 droid and integrates sensors that can detect people and then interact with them. This design uses six IR sensors and one main 8x8 IR sensor grid to be able to detect the closest person and turn BB-8’s dome towards them as though they are looking at them.

Chapter 1: Introduction

The first builders club was started by Dave Everett [1] as the R2-D2 Builders Club on the Yahoo Groups community in 1999 about the time “Star Wars: Episode I” was released in theaters. The club had the goal of supporting each other in the process of building their own replica R2-D2. For many years, the club existed as a community on Yahoo Groups before eventually moving to their own forums at Astromech.net. [2] They used all the resources available like studying the images of R2-D2 in the movies but also were able to get real measurements from some of the actual R2-D2 models used. From there, they were able to create a set of standardized club blueprints. Part runs were created where a club member could organize a shop to create dozens of a specific part for other club members to purchase as a group. For instance, the dome of R2-D2 is unique in its shape and how panels are cut out of it. A club member could organize a shop to custom make dozens of the R2-D2 dome made with the panels laser cut and sell them to other club members. This changed the way people could make their own R2-D2 because instead of trying to build a complete droid on your own, you have a standard set of blueprints to follow and the ability to buy custom parts that would be difficult to have produced individually by each builder.

The club continued to grow and in 2015, when BB-8 rolled onto the stage at Star Wars Celebration (a five day long convention only about Star Wars) promoting Star Wars: The Force Awakens, a group of builders decided to spin off a new club to build their own replica BB-8 [3]. There would be new design challenges as R2-D2 had plenty of room for motors, electronics, and batteries. Now, all of that had to fit inside and roll a 20” diameter ball. Many builders have been working over the past four years on drive designs for BB-8. Some drives are being beta tested by small groups of people, but there are two drives that are available for everyone to build. The first is “Joe’s Drive” made by Joe Latiola, which has a Facebook community of over 1,300 members in it [4]. It is an open source project that is designed to use 3D printed and off the shelf parts to construct the drive. The other public drive design is the “Cary Christie V1 Drive” designed by Cary Christie. The drive requires the purchase of a set of custom cut aluminum parts to have access to the build guide and the 3D printing files. The purchase of a custom electronic kit made by Stephane Beaulieu is also required to build the completed drive.

The BB-8 Builder’s Club has their own web forums [5] and their own Facebook Group [6] and I have been a member of the BB-8 Builder’s Club since December of 2015. Seeing the progress the club has inspired me to build my own BB-8 but I also wanted to be able to add something new that the club has not developed yet. About a year ago, I asked around if anyone had done any work on lightweight sensors and no one had for BB-8 so they encouraged me to do further research. This project will take an existing design for BB-8 and develop sensors that can integrate into the BB-8 drive.

Chapter 2: Project Planning

Customer Needs Assessment

The BB-8 Builders Club exists to help its members construct a working BB-8 or BB-style droid and with the club settling on a couple main designs, now is a good time to expand functionality and add features. After talking to the electronics designer of the drive system, Stephane Beaulieu, of the Cary's V1 Drive, he agrees that additional sensing ability would be a useful addition to the drive electronics. Using the expansion inputs on the dome electronics microcontroller, builders of the Cary drive BB-8 could add sensors to their BB-8 that would help it interact with people.

Requirements and Specifications

To add people sensing abilities to the Cary V1 Drive System designed by Cary Christie and Stephane Beaulieu. The expansion kit must integrate with the electronics in the dome of BB-8 as the dome microcontroller already connects via Bluetooth to the main drive system microcontroller. The two main constraints will be the weight of the additional electronics as well as the external appearance of the sensors. The dome of BB-8 sits on rollers and held on by magnets. Excess weight makes the dome harder to stay on so the weight of the additional electronics should be limited to eight ounces.

The appearance of the sensors must also blend in to the design of BB-8. The club prides itself on making BB-8 as screen accurate as possible, meaning the BB-8 they build looks as close as possible to the BB-8 show in the movies. Club members shouldn't sacrifice the design of BB-8 for the additional sensors. The package of the sensors must be small enough to mostly hide in the existing look of the BB-8 dome. Multiple features should be possible with the additional sensors, but it must detect people around it and look towards a person without guidance from the builder.

Table 1:
Human Sensing Expansion for a Rolling Robot Requirements and Specifications

Marketing Requirements	Engineering Specifications	Justification
1	Utilize expansion inputs on drive systems	Allows builders to add new features to their BB-8
3	Minimize external appearance	Builders want a screen accurate BB-8
2	Additional electronics must weigh less than eight ounces	Minimize the risk of the dome falling off
4	Detects a person within two feet	BB-8 can interact with a person without control of the builder
1, 3	Fit and package electronics with the dome	Must work with existing club design
1, 2	At least one-hour runtime on the battery	Needs a usable runtime without swapping the battery
5	Total cost under \$200	The cost should not price itself out of the

		market
4	Look at a person close to itself	Most common action a builder does when controlling a BB-8 around people
Marketing Requirements <ol style="list-style-type: none"> 1. Simple integration with Cary V1 Drive System 2. Wont risk damage to dome 3. BB-8 maintains screen accuracy 4. Allows BB-8 to interact with people 5. Affordable upgrade 		

Table 1 shows the requirements that the sensor expansion must follow and explains why these requirements are important. Most requirements are the result of the project needing to integrate into an existing BB-8

Table 2:
Human Sensing Expansion for a Rolling Robot Deliverables

Delivery Date	Deliverable Description
February 16 th	Mock Up for Drive Designers
March 22 nd	EE 461 Demo
March 22 nd	EE 461 Report
June 10 th	EE 462 Demo
June 13 th	ABET Sr. Project Analysis
June 13 th	EE 462 Report

Table 2 shows the main deadlines and milestones for this project

Functional Decomposition

Level 0 Block Diagram

The level 0 block diagram shows the overview of the system. It senses people around the BB-8 droid with Infrared sensors

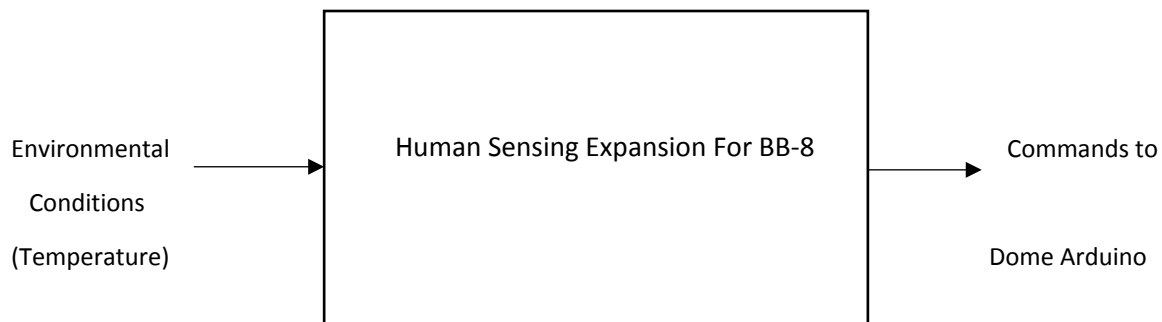

Figure 1: Level 0 Human Sensing Expansions for BB-8 functionality block diagram

Figure 1 shows the project level 0 block diagram that shows the project reading various temperatures and then outputting a directional heading for the dome Arduino

Table 3:

Human Sensing Expansion for BB-8 Functionality

Module	Human Sensing BB-8 Expansion
Inputs	The system measures the temperature around BB-8 with Infrared sensors
Outputs	Commands to move the dome or emit noise will be sent to the dome microcontroller
Functionality	Allows BB-8 to sense people 360 degrees around, find a person, and send a command to move the dome to look at the person

Table 3 explains more about the Level 0 block diagram and the functionality of this project

Level 1 Block Diagram

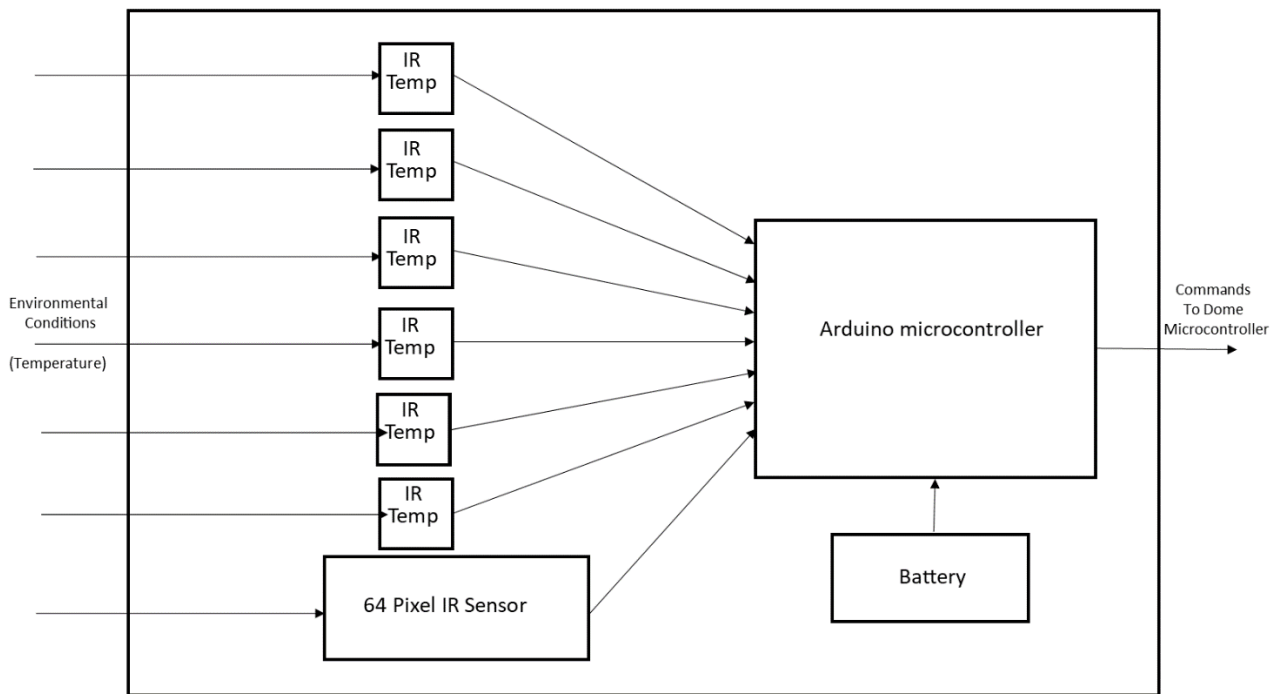

Figure 2: Level 1 sensor expansion block diagram

Figure 2 shows the sensor expansion block diagram. The Infrared temperature is being measured by the Melexis sensors and the 64-pixel Grid-Eye sensor

Table 4:

IR Temperature sensors from Level 1 block diagram

Module	IR Temp
Inputs	Six IR sensors measure the average temperature in 90-degree angles around BB-8
Outputs	I2C Bus signal with the average temperature and the ambient temperature
Functionality	When a person is close enough, the IR sensor will detect a temperature above the ambient level

Table 4 shows the functionality of the IR Temperature Sensors in this project. They will detect a person from the Infrared radiation being emitted and then output the temperature over the I2C bus.

Table 5:
6 Pixel IR temperature sensor from Level 1 block diagram

Module	64 Pixel IR Sensor
Inputs	An 8x8 IR sensor grid detects sixty-four temperature points in a 60-degree angle in the front of BB-8
Outputs	I2C Bus signal outputs the temperature of all sixty-four pixels
Functionality	The IR grid sensor will be able to detect the rough shape of a person and find the center of the heat source

Table 5 shows the functionality of the 64 Pixel IR sensor in this project. This sensor contains 64 individual Infrared sensors that will measure the temperature of an object and output the temperature data from each pixel via the I2C bus

Table 6:
Arduino Microcontroller from Level 1 block diagram

Module	Arduino Microcontroller
Inputs	Uses the I2C Bus to receive temperature data from each sensor
Outputs	Uses Software Serial to send heading data to dome Arduino
Functionality	Processes temperatures readings to determine where a person is and then send that location heading to the dome Arduino

Table 6 shows how the Arduino microcontroller functions in the Level 1 block diagram. It will take all the temperature readings from the sensors, perform calculations on them, and then output a directional heading for the dome Arduino

Timeline

Building a BB-8 droid and building a sensor system for it in two quarters is a very compressed time frame. I need to be working on construction of the drive while also working on the sensor project simultaneously.

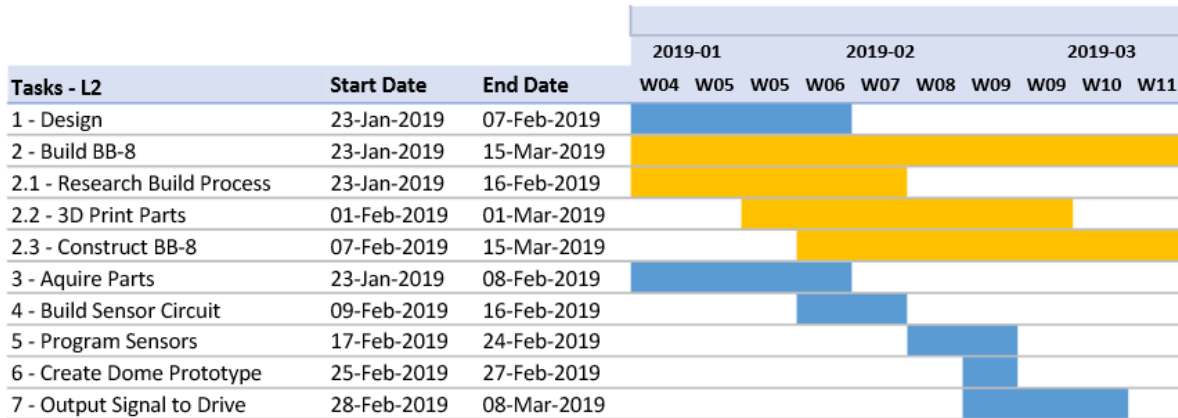

Figure 3:
Winter Quarter 2019 Estimated Timeline

Figure 3 shows the estimated progress that will be made in the Winter quarter. Since this project requires construction of a BB-8, I've made those tasks in orange and the tasks related to this project in blue.

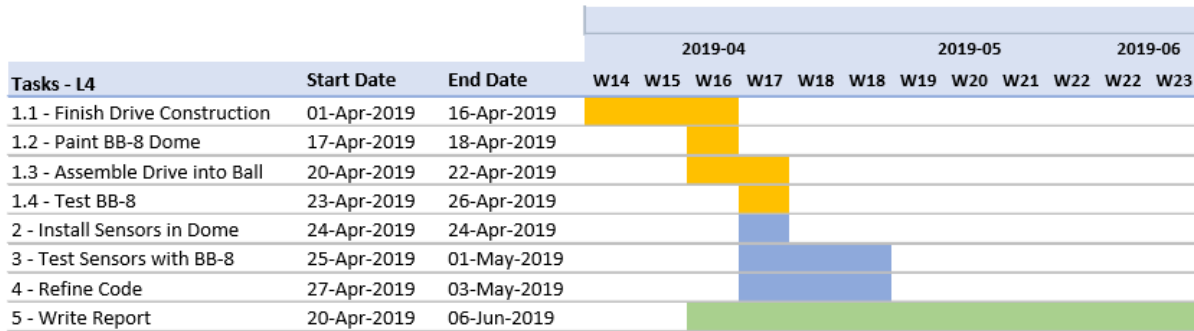

Figure 4:
Spring Quarter 2019 Estimated Timeline

Figure 4 shows the estimated progress that will be made in the Spring quarter. BB-8 tasks remain in orange, tasks involving the sensors are in blue, and writing up the report is in green.

Cost Estimates

At first, I thought I would only need four of the Melexis sensors, but in the end six were used. This was the initial cost estimate.

Table 7:
Initial Cost Estimates

Item	Quantity	Cost	Total
Arduino Microcontroller	1	\$20	\$20
IR Temperature Sensor Melexis MLX90614 3V	4	\$16	\$64
Adafruit Grid-Eye IR Array Breakout AMG8833	1	\$41	\$41
350 mA Lithium Ion Battery	1	\$10	\$10
		Total	\$135

Table 7 shows the initial cost estimates for the sensor project.

Chapter 3: Project Design

This section describes the parts that were chosen for installing sensors into the dome of BB-8

Thermopile Sensor

Both types of sensors being used in this project are based on thermopile technology. A thermopile sensor is a type of non-contact sensor that can measure the temperature of an object based on Infrared radiation being emitted by the object. The Infrared radiation from the object gets absorbed by a thin membrane on the surface of the sensor and the membrane then heats up or cools off. This causes a temperature difference between the thin membrane absorbing the Infrared radiation and the isolated mass of the rest of the chip. A voltage is then created from the difference in temperature and by comparing it to the sensor temperature, the object temperature can be calculated. [7]

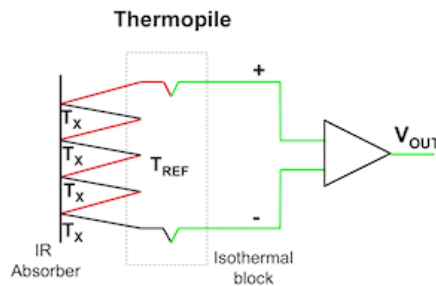

$$V_{OUT} = N \cdot S \cdot (T_x - T_{REF})$$

S: Seebeck coefficient

N: Number of thermocouples

Figure 5[7]

Thermopile Voltage Diagram

Figure 5 shows how the temperature difference between the IR Absorber membrane and the rest of the chip create an output voltage that can be measured and then used to find the temperature of the object.

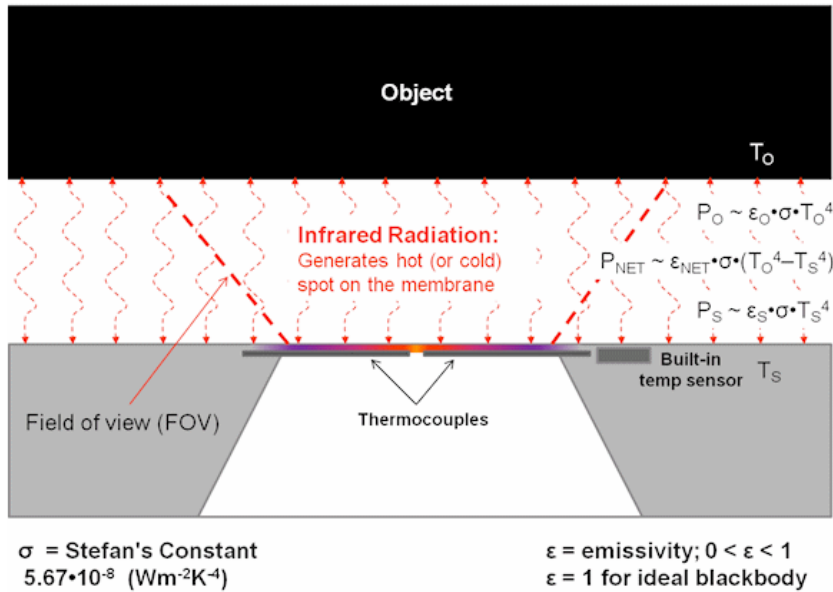

Figure 6[7]
Diagram of a Thermopile

Figure 6 shows how the Infrared radiation of an object warms up the thin membrane of the thermopile and its temperature is compared to the built-in temperature sensor in order to calculate the temperature of the object.

Primary Sensor: Adafruit AMG8833 Panasonic Grid-Eye Breakout

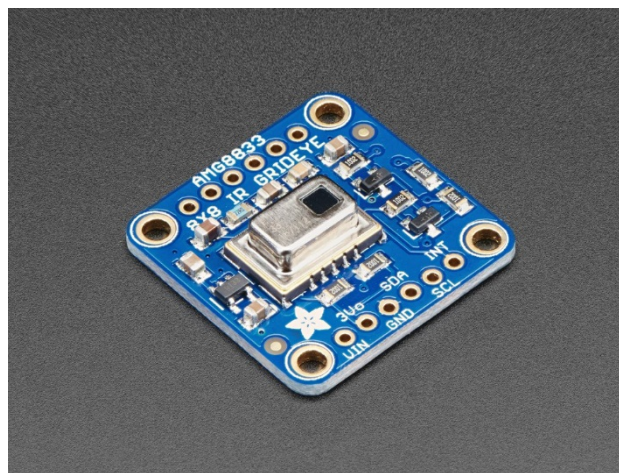

Figure 7 [8]:
Panasonic Grid-Eye Breakout from Adafruit

The primary sensor is a Panasonic Infrared Grid-EYE sensor combined with a breakout board that allows it to be powered by either 3.3V or 5V that will scale the output to the input voltage. The

Panasonic Infrared Grid-EYE sensor is an 8X8 pixel array (eight horizontal by eight vertical) of thermopile sensors that form a 60 degree field of view in the horizontal and vertical directions. Each pixel has approximately a 5.5 field of view.

Secondary Sensors: Melexis MLX90614



Figure 8 [9]:
Melexis MLX90614

The Melexis MLX90614 is a thermopile infrared detector with a signal conditioning circuit in a single package. It can measure both the object temperature and the ambient temperature and output the data via the I2C bus.

The Melexis sensors use the I2C bus for communication as well but each sensor comes with the same I2C address. However, one feature of this sensor is that a desired new I2C address can be written to the sensor and it keeps the address in the memory. Using the resources that [blank made](#), I was able to set the address of each Melexis sensor so that each one could be address individually by the Arduino.

Adafruit METRO 328 – (Arduino Uno Clone)

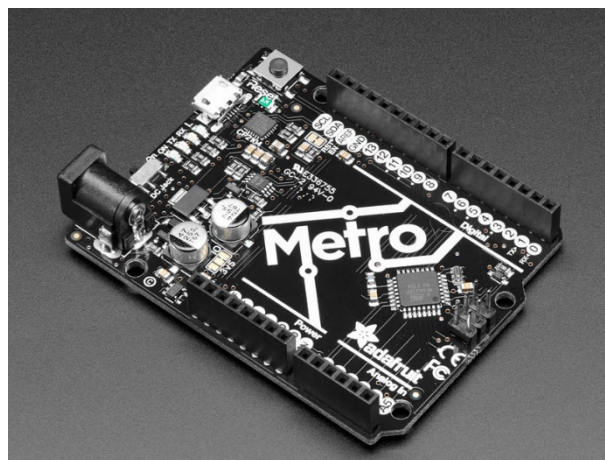

Figure 9[10]:
Adafruit METRO 328

This Arduino board was used because it looked to be very flexible for the project and could be purchased with the sensors at the same time. Most other Arduino boards should be work just as well for this project.

Chapter 4: Project Development

Communication between Arduinos

The first step was determining the best method of communication between the sensor project Arduino and the existing dome Arduino, or even directly to the drive Arduino. Then, Stephane and I had to figure out how he would like the direction signal to be formatted. After meeting in person at the Star Wars Celebration convention and messaging via Facebook Messenger, we determined that Software serial using the NeoSWSerial [11] would work best. The existing serial connection of the dome Arduino was being used by the Bluetooth transmitter which was communicating to the drive Arduino. NeoSWSerial also has the benefit of working on user definable output pins. This would be flexible to integrate with the dome Arduino which already had pins in use to control lights inside the dome.

The decision about how the signal would be formatted was up to Stephane since he knew the system I had to integrate with, and he is the only one with access to the code that operates the drive. He determined that he would prefer to receive a signal with the desired heading from 0 to 359.

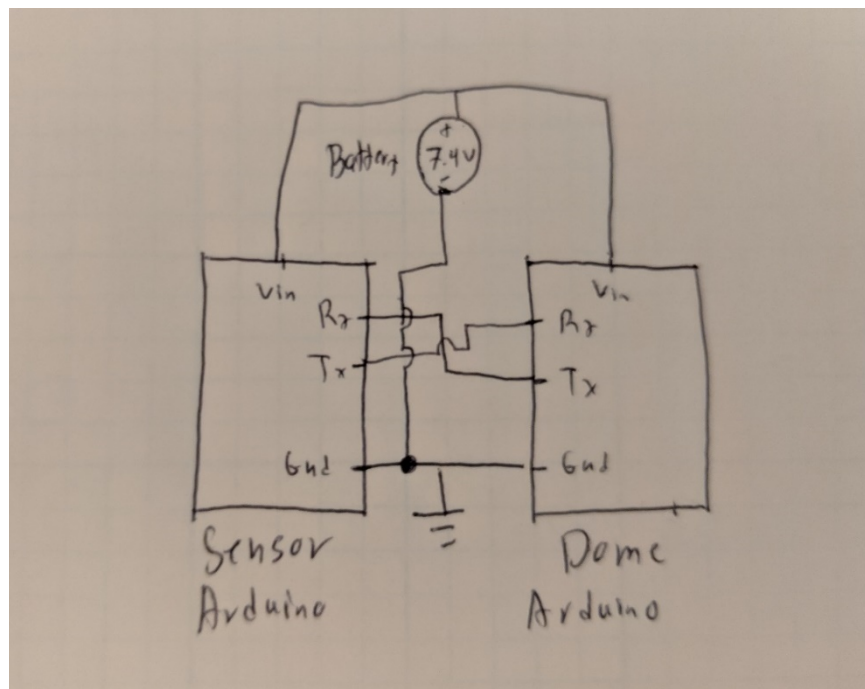

Figure 10:
Schematic of Connection Between Sensor and Dome Arduinos

Figure 10 shows how the Sensor and Dome Arduinos are connected via Software Serial

Sensor Prototype

The prototype was built with a clear plastic version of the BB-8 dome which I purchased from a builder at the builders' workshop I went to in Arizona. It was a perfect way to sample mounting the sensors without using the main BB-8 dome. Four Melexis sensors were mounted to the front, back, and sides of the BB-8 dome and the primary Grid-Eye sensors was mounting to the front of BB-8 where his "eye" is. The numbers are the blue tape indicate the pixel number that is located in that corner of the



sensor package.

Figure 11
Prototype Created for Sensor Testing

At first, I used four sensors because each sensor had a 90-degree coverage and I wanted to see if that would be sufficient to cover the area around the dome. For this prototype, I also made a test program adapted from the Adafruit [12] and Sparkfun examples [13] using existing software libraries that would check which Melexis sensor detected the biggest difference in temperature above the ambient temperature and would find which pixel from the Grid-Eye sensor detected the most heat.

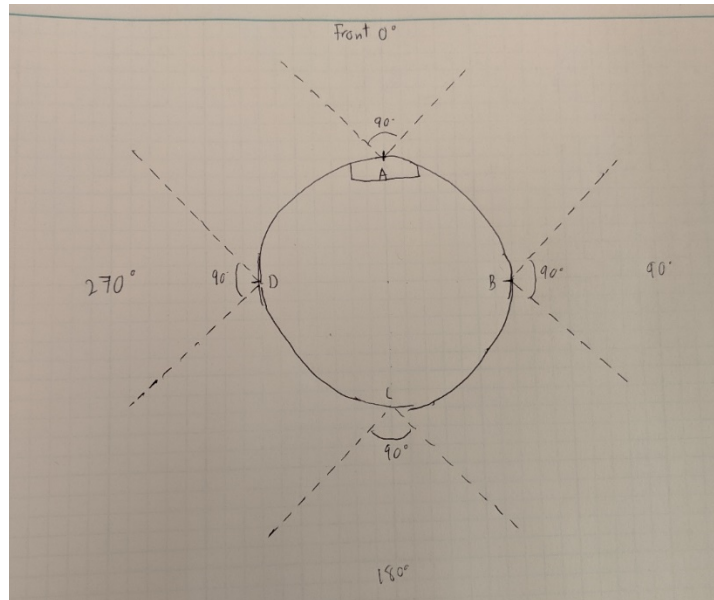

Figure 12:
Field of View Diagram of Four Sensor Prototype

Figure 12 shows the field of view of the four Melexis sensors on the prototype. There is a gap between the field of views because the sensors are at a distance apart from each other.

The sensors were able to pick up a person completely around the dome, but the performance wasn't best in the small gap in coverage between each sensor. For the final installation in the dome, I decided to use six sensors placed 60 degrees apart instead. There would be coverage overlap between the sensors and the Arduino would have a better understanding of where a person was around the dome and the initial movement of the dome to point to someone would be more accurate. The height of the Melexis sensors were determined by where the front Melexis sensor looked best inside BB-8 eye which ended up being about 3" above the silver ring. The sensors at that placement area were pointed upward slightly which also seems to work well.

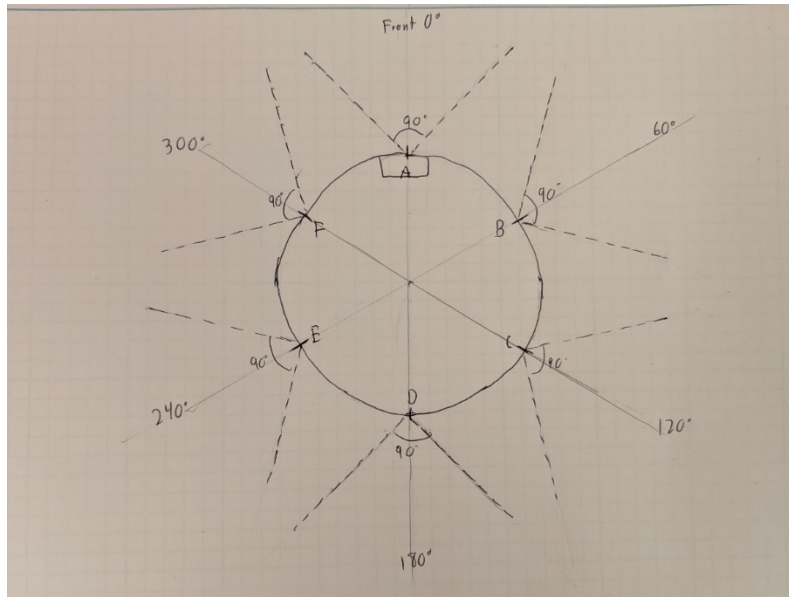

Figure 13:
Final Sensor Field of View Diagram

Figure 13 shows the field of view from all six sensors. The coverage gap is only very close to the dome and will not affect performance



Image of Sensor Placement in Dome

Figure 14 shows where two of the Melexis sensors and the Grid-Eye sensor are placed on the dome. Melexis Sensor F is in the left part of the image. Melexis Sensor A and the Grid-Eye sensor are in the eye of BB-8.



Figure 15
Sensors Wired in Dome

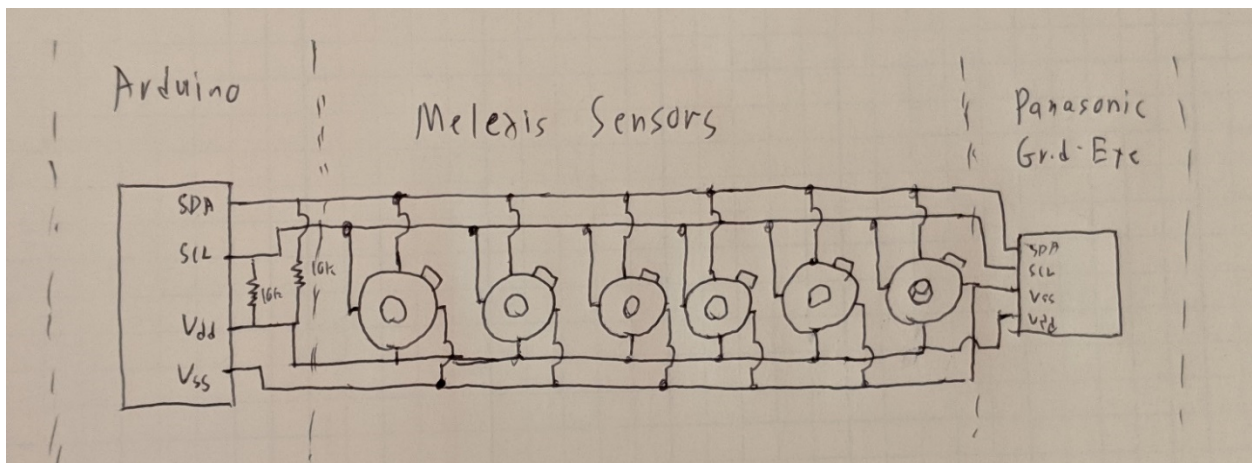

Figure 16
Schematic of Sensors

Figure 16 shows how the sensors are wired to the Arduino using the I2C bus. There are 10k Pull Up resistors on the SDA and SCL lines.

Chapter 5: Testing and Design Verification

The goal of this project was to have the drive of BB-8 itself be able to turn the head and test the sensors. However, Stephane had other more pressing matters and was unable to finish the code for the drive and dome Arduinos to integrate into my system and to test it. Instead of being able to test the sensor project directly on BB-8, I had to make a test platform to verify the operation of the sensors.

Test platform Design

I was limited with what I could design since the platform had to be able to take the signal that Stephane and I already agreed on and be able to turn the dome 360 degrees. Since most servos have a maximum range of 180 degrees, I thought about having to use gears for a servo to be able to turn in a complete 360-degree range. However, I found one servo that is used for winches to control the sails on some RC boats and can rotate eight turns [14]. This servo is also used in my BB-8 drive to tilt the drive inside the ball. I used the exact same Arduino Nano that would be used in the dome to receive the signal from my sensor Arduino and control the test platform servo. I used left over parts from my BB-8 build and printed another bracket that the BB-8 head can mount on to.



Figure 17:

Bracket to Attach Dome to Servo

Figure 17 shows the mechanism for how I attached the dome to the servo. The white piece is a part normally used inside BB-8 and was attached it to a servo hub via a rod.

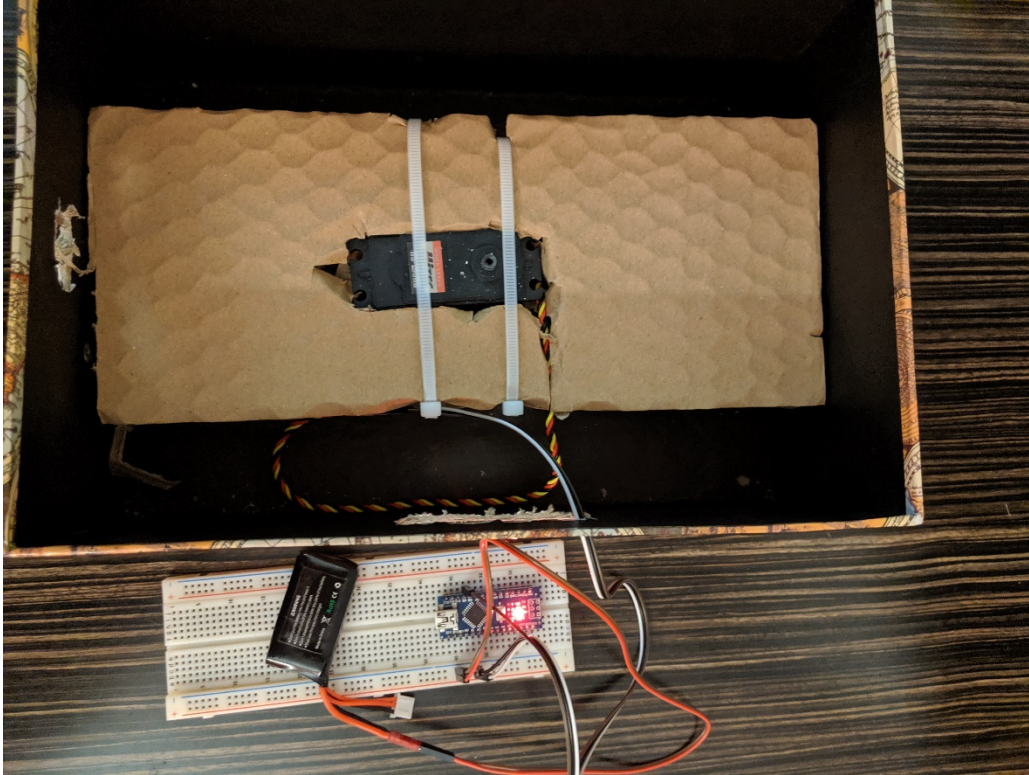
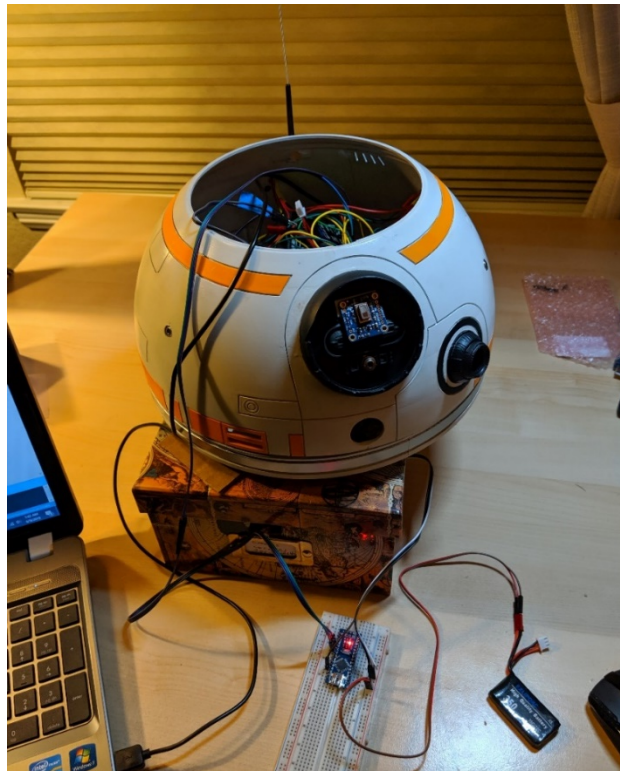

Figure 18

Image of Test Device Used

Figure 18 shows the simple test setup I used. The servo is in a box and the dome of BB-8 will attach to the servo gear which is being powered but the Arduino and an additional battery.

The code used to turn the servo using the Software Serial input from the Sensor Arduino was adapted from a servo test program written by "ZoomKat" [15].



Results

The ambient room temperature is a key factor in the performance of these sensors. In a cool, air-conditioned room, the Melexis sensors could detect a person about two feet away and the front Grid-Eye sensor could pick out from a similar distance. However, my final test was done in a room at around 80 degrees and the distance the Melexis sensors could detect a person was only about a foot. The warmer the environment, the less temperature difference a person is above the surrounding air and so it is harder to detect a person.

The Grid-Eye sensor also seemed to not be able to settle on one spot on the sensor and so the output heading from it seem to move around a bit. The sensor does perform some data averaging already, but I think some more coding work needs to be done

The Melexis sensors do blend in nicely with the dome. They are very small, lightweight and most people will not realize they are sensors. The Grid-Eye sensor in the front does fit in the eye of BB-8. However, BB-8 usually has a clear plastic lens in front of its eye. Since glass and most types of plastics completely block Infrared radiation, I had to leave the clear lens off of BB-8. Some people may notice the missing dome, but many will not.

Final Cost of Materials

Table 8:
Final Cost of Sensor Project

Item	Quantity	Cost	Total
------	----------	------	-------

METRO Arduino Microcontroller	1	\$18.86	\$18.86
IR Temperature Sensor Melexis MLX90614	6	\$17.24	\$103.44
Adafruit Grid-Eye IR Array Breakout AMG8833	1	\$43.10	\$43.10
350 mA Lithium Ion Battery	1	\$10.78	\$10.78
Hookup wire pack	1	\$17.44	\$17.44
		Total	\$193.62

Table 8 shows the final cost of just the sensor project. The costs were greater than the estimates because two additional Melexis sensors were used in the final setup

Table 9:
Cost of Test Setup

Item	Quantity	Cost	Total
Arduino Nano Microcontroller	1	\$5.00	\$5.00
Hitech HS-785HB Servo	1	\$53.88	\$53.88
Clamping D-Hubs (0.25")	2	\$7.54	\$15.08
1/4" Stainless Steel D-Shafting 3" long	1	\$2.36	\$2.36
Standard Hitec Hub Horn	1	\$6.47	\$6.47
350 mA Lithium Ion Battery	1	\$10.78	\$10.78
Misc. Breadboard Hookup Wire	1	\$5.39	\$5.39
			\$98.96

Table 9 shows the additional costs of the test setup I made to test the sensors. These expenses would not be needed if someone were to integrate the sensors into the dome.

Table 10:
Results of Sensor Project compared to the Specifications

Marketing Requirements	Engineering Specifications	Results
1	Utilize expansion inputs on drive systems	Yes, using Software Serial on Arduino
3	Minimize external appearance	Melexis sensors are very small and the Grid-eye mounts inside the eye. No lens possible however in front.
2	Additional electronics must weigh less than eight ounces	Sensors, Arduino, and battery only added 2.5 ounces
4	Detects a person within two feet	Yes, in a cooler room only
1, 3	Fit and package electronics with the dome	Yes, plenty of room inside dome for sensors
1, 2	At least one-hour runtime on the battery	Yes, the battery lasts well over an hour.
5	Total cost under \$200	Yes, but very close when using six Melexis sensors
4	Look at a person close to itself	It needs further improvement, but it does work well

Marketing Requirements

1. Simple integration with Cary V1 Drive System
2. Wont risk damage to dome
3. BB-8 maintains screen accuracy
4. Allows BB-8 to interact with people
5. Affordable upgrade

Table 10 shows the results compared to the specifications laid out at the beginning of the project. The project fulfills all the specifications except that the performance of the sensors requires a cooler room for proper performance.

Future Improvements

The most work needs to be done on the performance of the Grid-Eye sensor. Coding work may be done for heat mapping the pixels to hopefully get better results from the sensor. A different type of sensor may be an alternative as well, but it would have to follow the same specifications for this project. The Melexis sensors could be moved to the lower ring of BB-8 if the dome is adapted to be a solid piece. Right now, the dome spins above the silver ring so it was not possible to put the sensors in the ring for this project.

The sensor project also needs to be fully tested with the actual BB-8. The time frame of this project made it hard for the new drive code to be written in time. Stephane will have to make significant changes to his code to allow for signals to be sent from the dome Arduino to the drive Arduino. Right now, the dome only receives data from the drive Arduino. I will continue to work with Stephane after the completion of this project to see out the full goal of this project.

Chapter 6: Conclusion

The project was successful in being able to add people detecting sensors to the dome of BB-8 and have them mostly blend in with the established look of BB-8. The weight was also key to the design and only 2.5 ounces was added to the total weight of the BB-8 dome, well below the initial goal.

One of the limiting factors in this design was the nature of thermopile-based sensors. They read the object temperature based on the infrared radiation being emitted and compare it to the surrounding ambient temperature. This works well when the ambient temperature is an air-conditioned room, but the performance is much less in a warm room. The Melexis IR sensors do work well even with this limitation to surround the dome of BB-8 and give it a rough idea of where a person is, but it is worth researching into a different primary sensor for the front of the BB-8 dome and have it still meet the requirements laid out in this project.

This project has meant a lot to me as I have dreamed of having my own replica droid from Star Wars for years now and it has allowed me to give something back to the BB-8 builders community for others to use and build on. The BB-8 Builders Club and the other droid building communities rely on each other for support and growth since no single person can design and build a droid without any assistance. There has been interest in adding sensors to BB-8 for a while now so I hope this project is a useful starting place for those builders and is a resource for them. I plan on remaining active in the community, so I welcome anyone to reach out to me on the BB-8 Builders forum or BB-8 Builder's Facebook group.

BB-8 and this project have also rekindled my love of engineering. There was a large gap of time where I was working in a different industry before I was able to do this project and finish my degree. While I enjoyed what I did, this project reminded me why I wanted to be an Electrical Engineer in the first place and motivates me to change my career path. A large part of the droid builders community involves STEM outreach for children and I plan to use this passion to show young people what is possible and to hopefully inspire future engineers. Seeing BB-8 in person for the first time gave me a giant smile so I want to spread that joy to other people with BB-8

References

- [1] "Meet the Man from Down Under. R2 Builders Founder Dave Everett", *R-Series Magazine*, Vol. 1, Dec. 2004. [Online]. Available: <https://astromech.net/droidwiki/images/2/22/R-Series-Vol.1Dec04.pdf>
- [2] <https://astromech.net/forums/index.php> [Accessed: June 2019].
- [3] <http://bb8builders.club/wiki/index.php?title=About> [Accessed: June 2019]. Registration is required to view.
- [4] <https://www.facebook.com/groups/JoesDrive/> [Accessed: June 2019].
- [5] <http://bb8builders.club/forum/> [Accessed: June 2019]. Registration is required to view.
- [6] <https://www.facebook.com/groups/BB8BuildersClub/> [Accessed: June 2019]. Member approval required.
- [7] <https://www.sensormag.com/components/demystifying-thermopile-ir-temp-sensors> [Accessed: June 2019].
- [8] <https://www.adafruit.com/product/3538> [Accessed: June 2019].
- [9] <https://www.adafruit.com/product/1747> [Accessed: June 2019].
- [10] <https://www.adafruit.com/product/2488> [Accessed: June 2019].
- [11] <https://github.com/SlashDevin/NeoSWSerial> [Accessed: June 2019].
- [12] https://github.com/adafruit/Adafruit_AMG88xx [Accessed: June 2019].
- [13] https://github.com/sparkfun/SparkFun_GridEYE_Arduino_Library [Accessed: June 2019].
- [14] <https://www.servocity.com/hs-785hb-servo> [Accessed: June 2019].
- [15] <https://forum.arduino.cc/index.php?topic=96504.0> [Accessed: June 2019].
- [16] <https://www.facebook.com/groups/1081301168600069/> [Accessed: June 2019].
- [17] <https://www.caryeng.com> [Accessed: June 2019].
- [18] <https://www.facebook.com/groups/484001088771454/> [Accessed: June 2019]. Private Facebook group
- [19] "Carys BB8 V1 Drive Assembly Guide Revision 8"
- [20] <https://www.tinymachines3d.com/> [Accessed: June 2019].
- [21] <https://www.printedsolid.com/blogs/news/we-are-ending-our-relationship-with-creality> [Accessed: June 2019].
- [22] <https://atomicfilament.com/> [Accessed: June 2019].
- [23] <https://enviroliteracy.org/special-features/its-element-ary/silicon/> [Accessed: June 2019].

[24] <https://www.creativemechanisms.com/blog/learn-about-polylactic-acid-pla-prototypes> [Accessed: June 2019].

Appendix A: Building a BB-8 Droid from Star Wars

I have been a member of the BB-8 Builders Club since 2015 and while I was not actively building a BB-8 robot, I was following along the progress of other builders. This design project was motivation build my own BB-8. This appendix shows an overview of the build choices I made and the build progression of BB-8.

Build choices

There are two main choices that must be made. First, you must decide on what type of ball design you are going to use for BB-8's main body. The second choice is the type of internal drive system that moves the ball and moves the dome rolling on top of it

Ball Design

At first some builders in the club used a clear, 20" diameter polycarbonate sphere for the body of BB-8. However, these spheres were hard to work with and proved hard to work on the drive while it was inside the ball. Since then, most builders have gone either with a skeleton frame inside the ball with exterior 3D printed panels or the "Vonjet Sphere" design [16] which uses thicker 3D printed panels as an exoskeleton. While the Vonjet Sphere is a very popular design, I still was not confident enough in my 3D printer for weeks of printing the Vonjet Sphere requires. Vonjet panels also require more finishing work to join the panels together and I had a very condensed time frame in which to build BB-8. Instead I purchased an injection molded skeleton kit from Cary Christie [17] and would 3D print the exterior shell.

Figure A2[17]:
Injection Molded Skeleton Kit

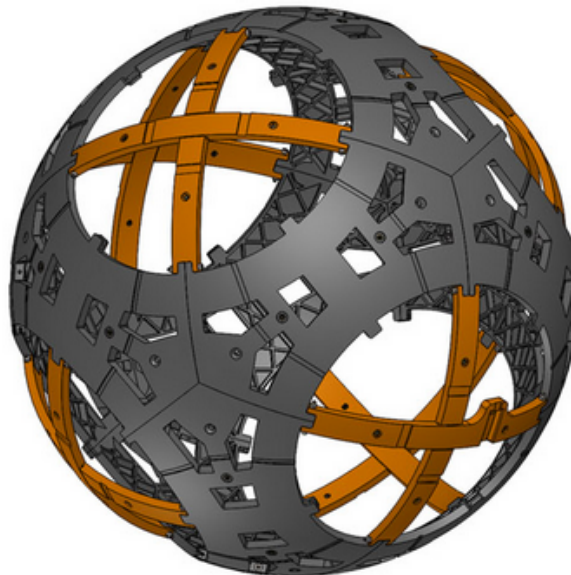

Interior Drive Design

The design of BB-8 makes designing a drive very difficult. Everything must be able to fit inside a rolling ball. The club builders have spent the last four years working on drive designs and only two have been public for others to build. One choice is “Joe’s Drive” [4] designed by Joe Latiola and has been made fully open source. The other is “Cary Christie’s V1 Drive” [18] designed by Cary Christie which requires the purchase of custom cut aluminum parts to have access to the build guide and the 3D print files required to build the drive. The drive also requires the purchase of a custom electronics kit designed by Stephane Beaulieu. There are other drive designs that have been partially finished or are still being developed so there may be other public drive options in the future.

I chose the Cary Christie drive as it appeared to have more documentation how to build it and people were able to construct their Cary Drive BB-8 in just a few months. Since time was very limited, it was important to see that others were able to build a BB-8 in a short period of time.

Figure A2 [19]
3D rendering of completed Cary V1 Drive

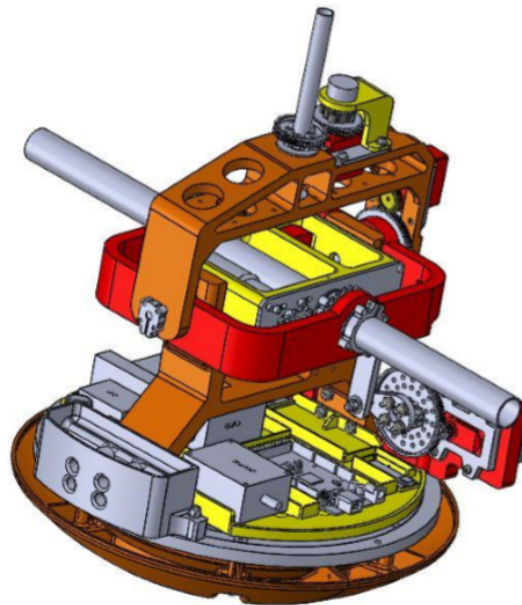

3D Printing

The most difficult requirement to build a BB-8 is that you need access to a 3D printer with at least a 12”X12”X12” build volume to be able to print all of the pieces required for both the drive and the exterior shell of BB-8. This is actually a very large build area for a 3D printer and severely limits that options available. Luckily, one of the more recently popular 3D printers made by Creality has the required build volume; the Creality CR-10s. I purchased the printer from Tiny Machines [20] where they test the printers they sell before they send them out. The Creality CR-10s can be purchased for cheaper

elsewhere but Creality machines have been known to need adjustments or even have faulty parts straight out of the box [21]. Since I was new to 3D printing, I decided it was worth the premium to purchase the printer from Tiny Machines since it was still much cheaper than other printers with a similar build volume. The 3D printer was purchase in early September of 2018 before I had begun work on BB-8 since I know how important it was going to be for the building process.

Figure A3:
Creality CR-10s 3D Printer Purchased and Setup

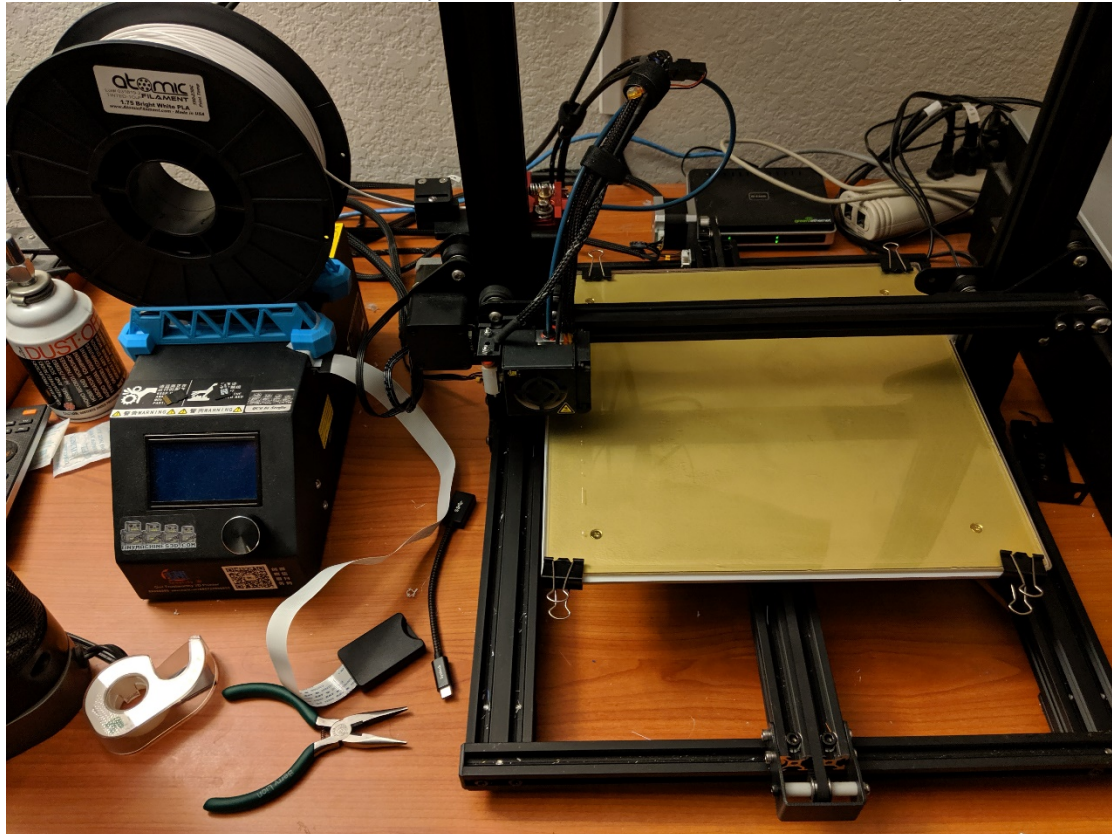

Acquiring Parts

After getting the go ahead for the senior project. Large orders were placed at ServoCity, Adafruit, Amazon, and McMaster-Carr for the parts listed in the Cary Drive Bill of Materials. The BoM was not 100% complete so additional orders were placed with various vendors during the duration of the project but thankfully nothing help up progress of the drive construction for more than a day or two.

Figure A4:
Majority of Drive Parts Labeled and Organized



3D Printing Parts

The first work was to start printing the pieces required for the drive. Most pieces took between 15 and 40 hours to print. 3D Printer filament is a PLA type ordered from Atomic Filaments [22]. In the end about one roll of blue, two rolls of gray, two rolls of orange, and about five rolls of white were used to print the drive pieces as well as the outer shell of BB-8. Much filament was wasted from failed prints that required trouble shooting the printer but that is the current nature of 3D printing.

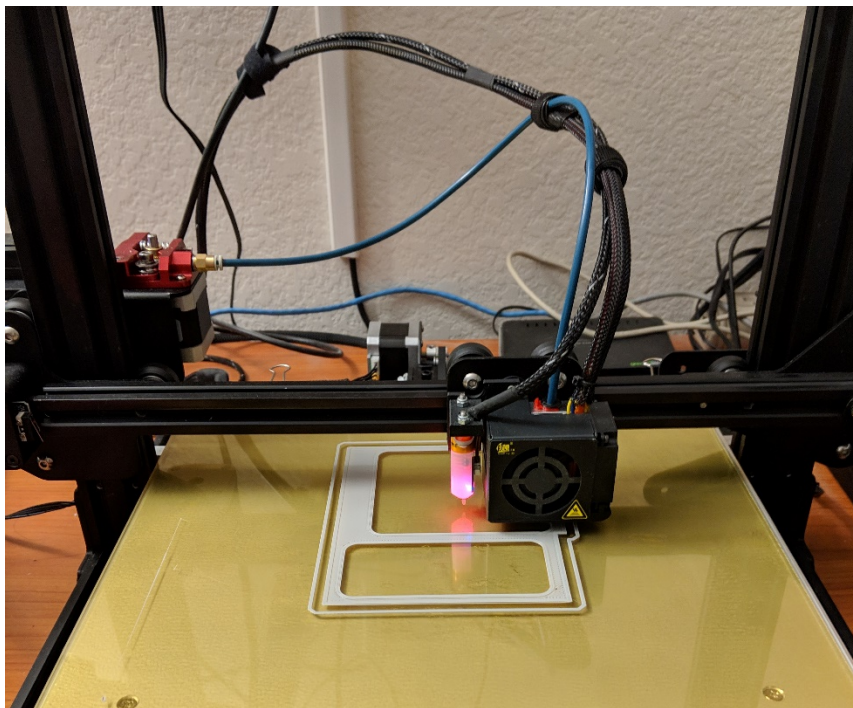
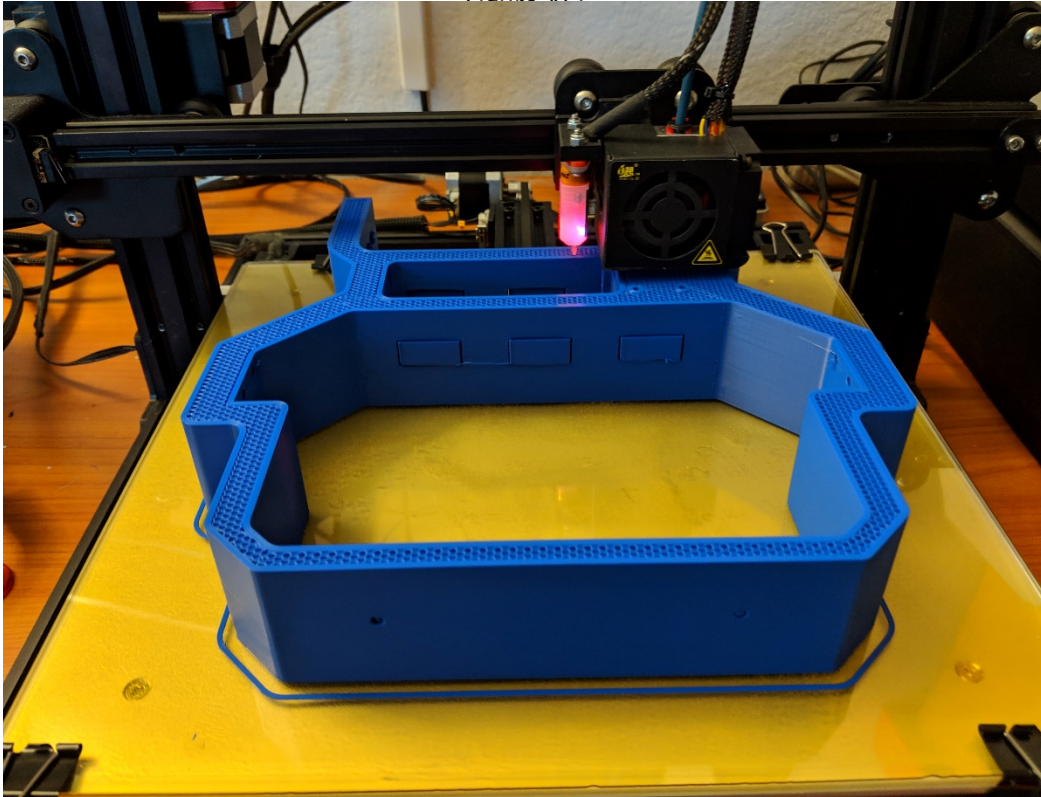
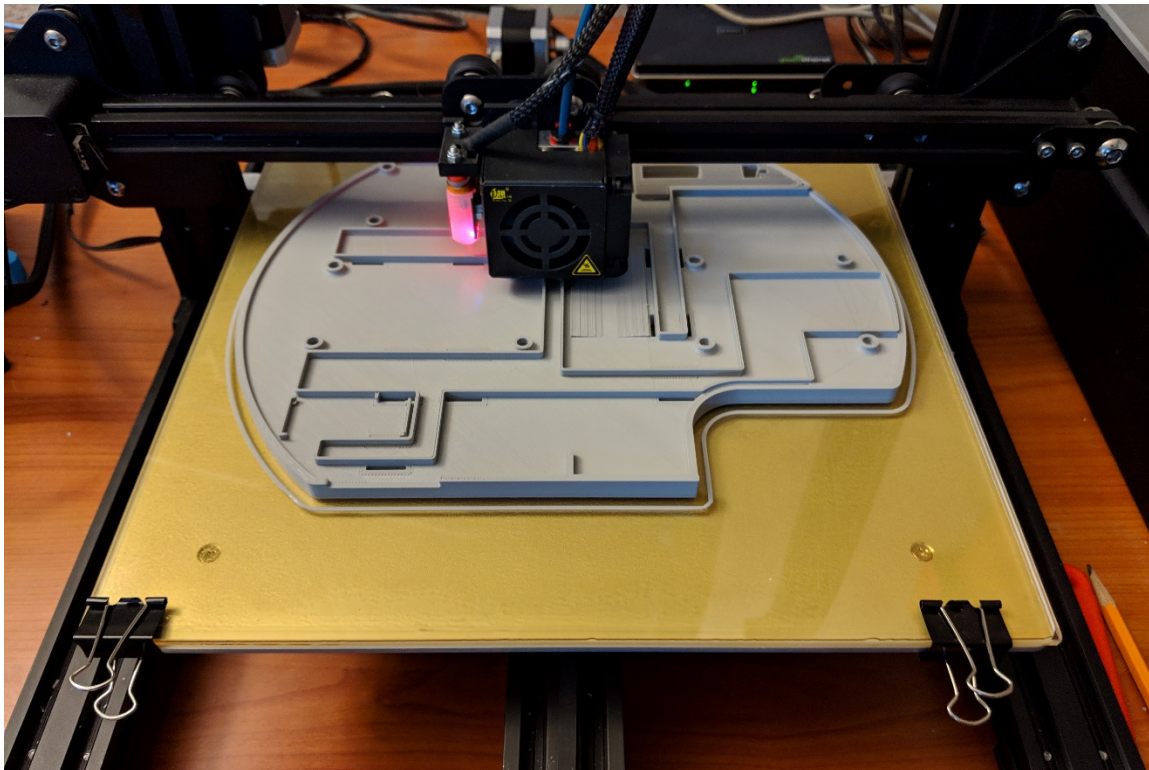

Figure A5:
It Begins: First Drive Piece Being Printed



Main Body Piece Being Printed

Figure A7:



Electronics Platform Being Printed
Figure A8:

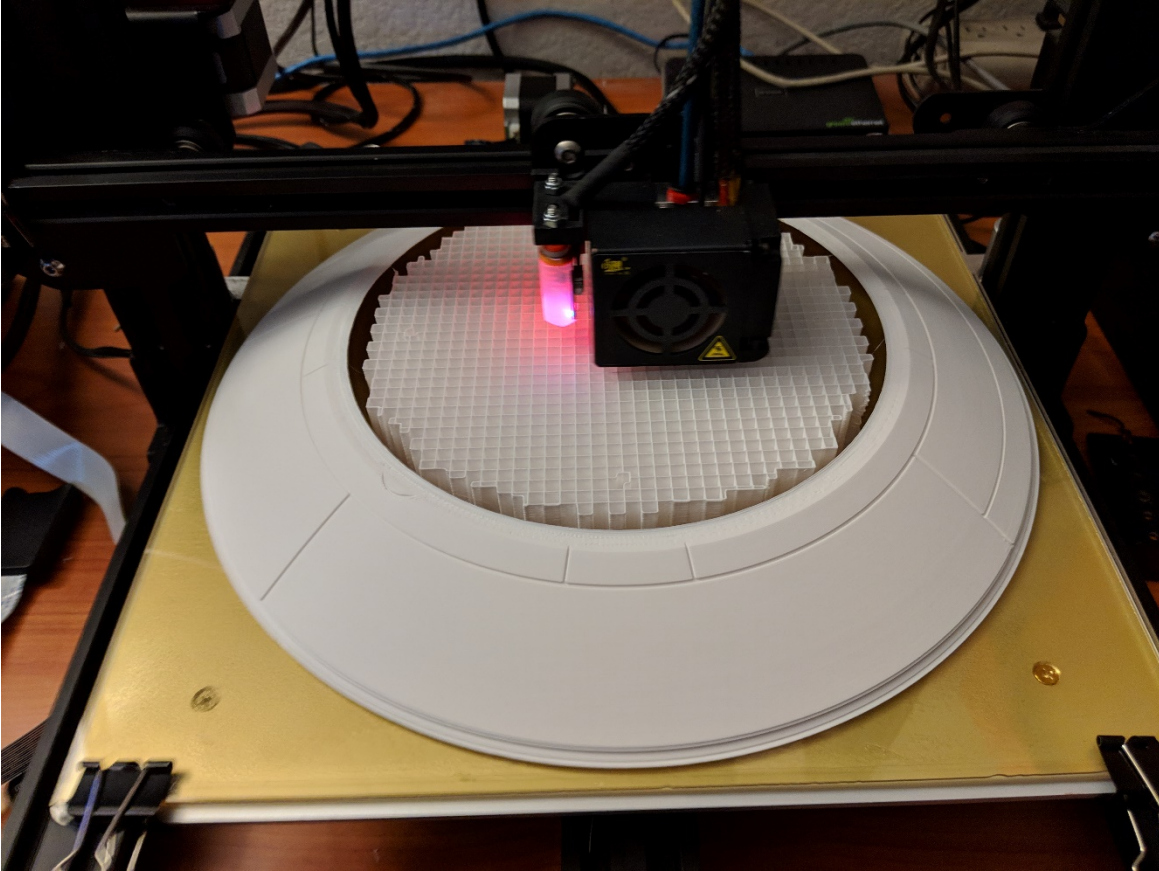

"Circle" Piece of BB-8's Exterior Shell

Figure A9:

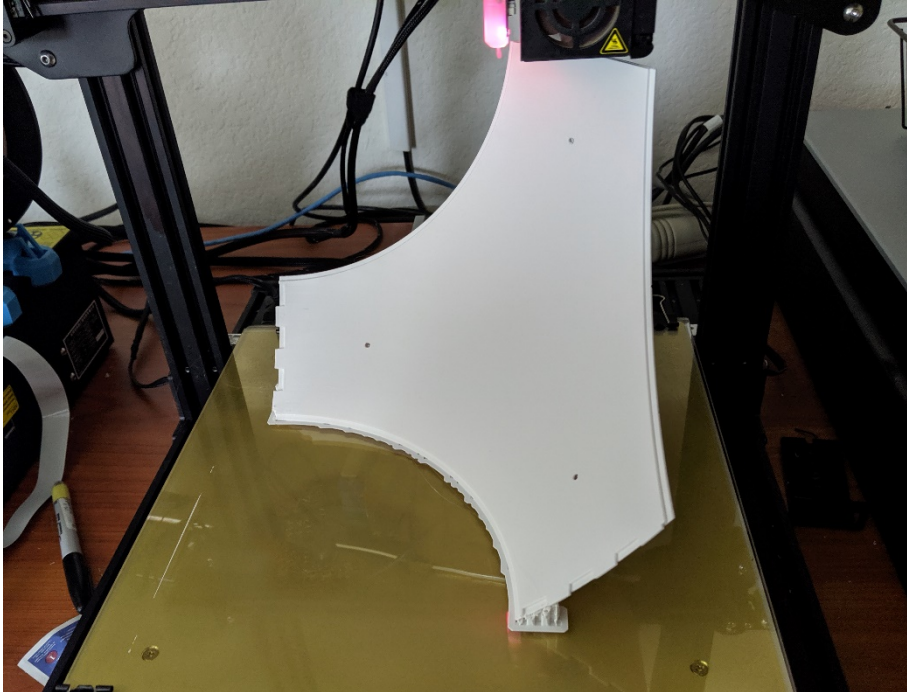

“Triangle” Piece of BB-8’s External Shell

Build Process

The assembly guide for the Cary Drive BB-8 was clear and well written, but still was a very time consuming process. Here are some pictures I took during the drive construction. All the aluminum pieces had to be filed for proper fitment and sometimes proved to be very time consuming since there would be issues if too much material was filed off. Most screws were secured with Loctite Adhesive once the proper fitment was assured. This prevents parts from wiggling loose during normal operation of BB-8. The ends of most screws also had to be cut off with a Dremel tool so that they would not get in the way of other moving drive parts. The wiring of the electronics platform was less guided, and I had to rely on the schematic and other examples I saw in the group to assemble and wire the platform. I also assembled the battery pack using ten 1.2 V NiMH cells. The battery pack sit at the base of the drive below the electronics platform.

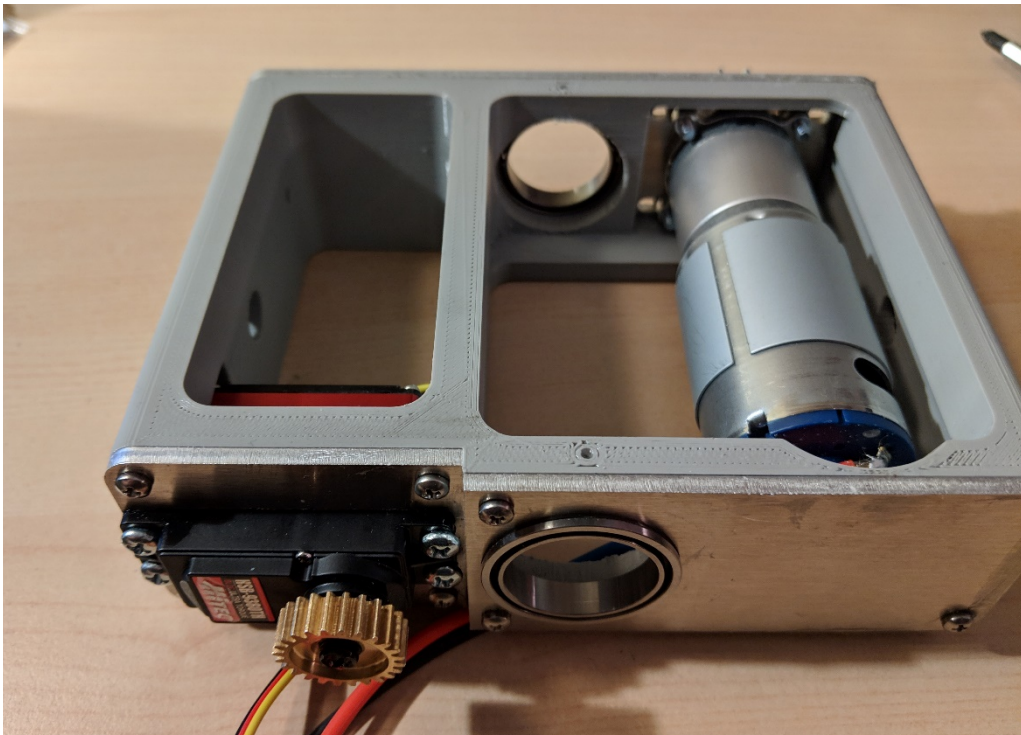
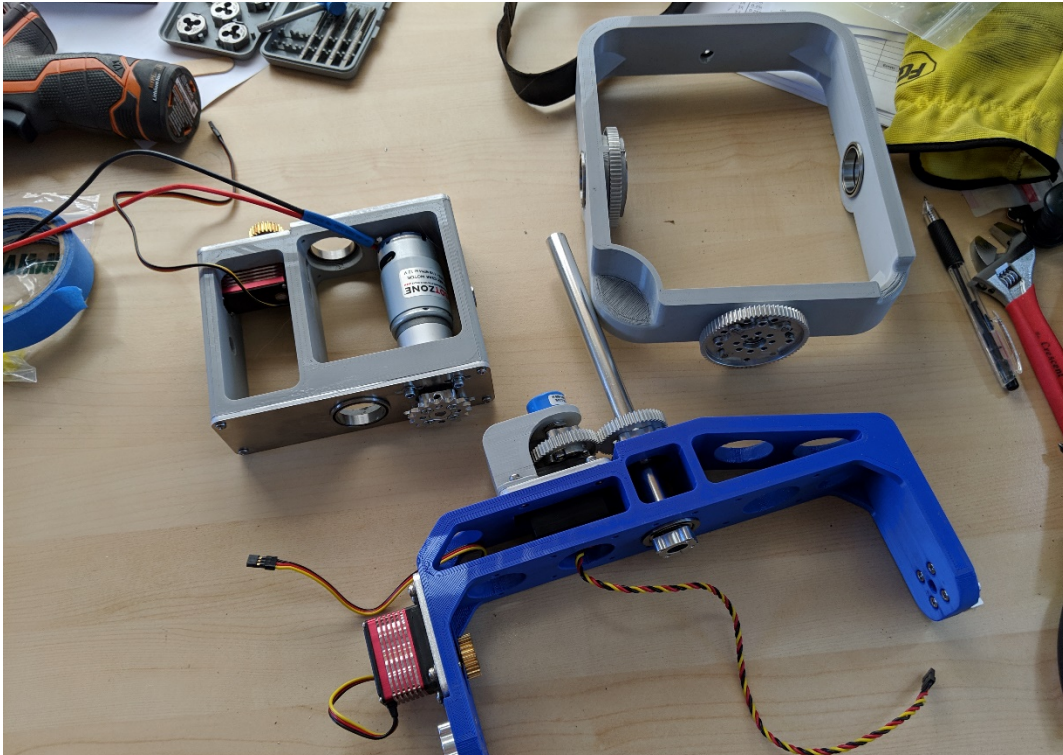

Figure A10:
First Major Drive Piece Assembled

Figure A11:



Three Pieces of Assembled Drive

Figure A12:



Piece of Constructed Drive Frame
Figure A13:

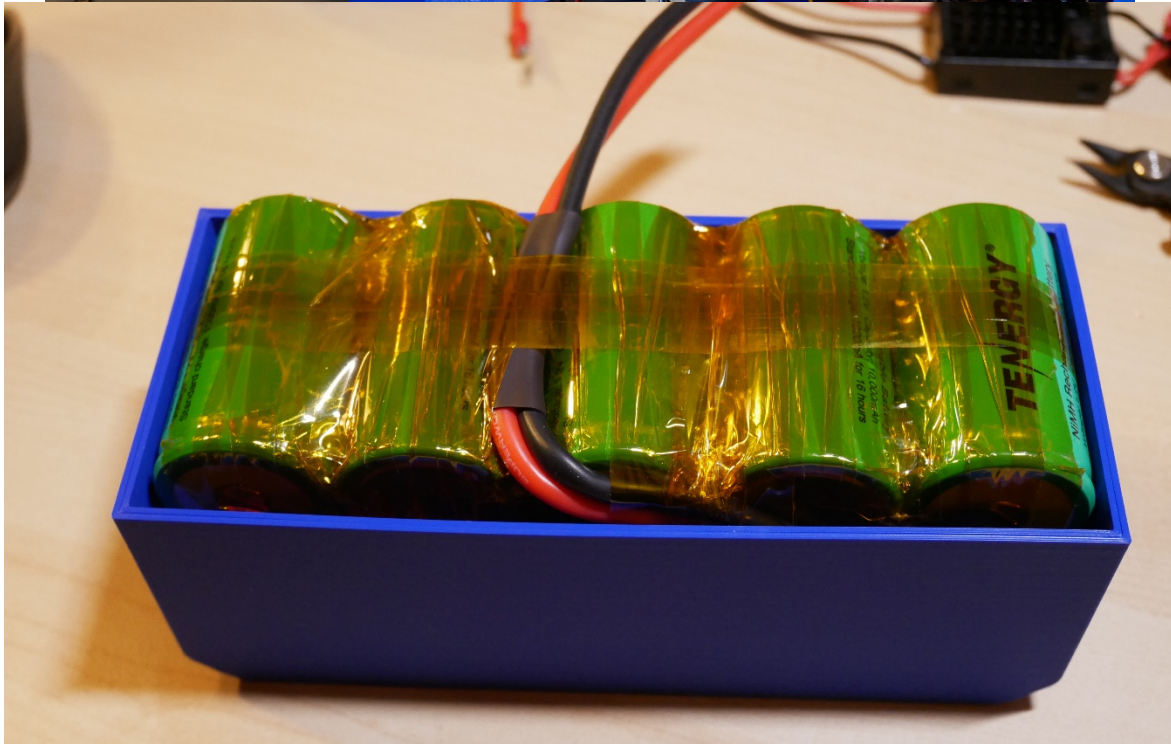
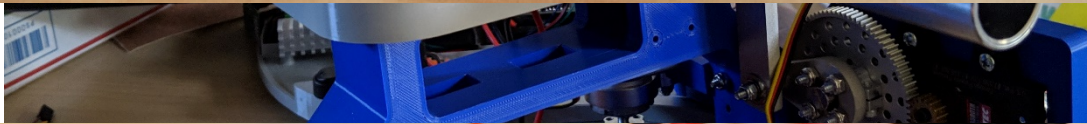
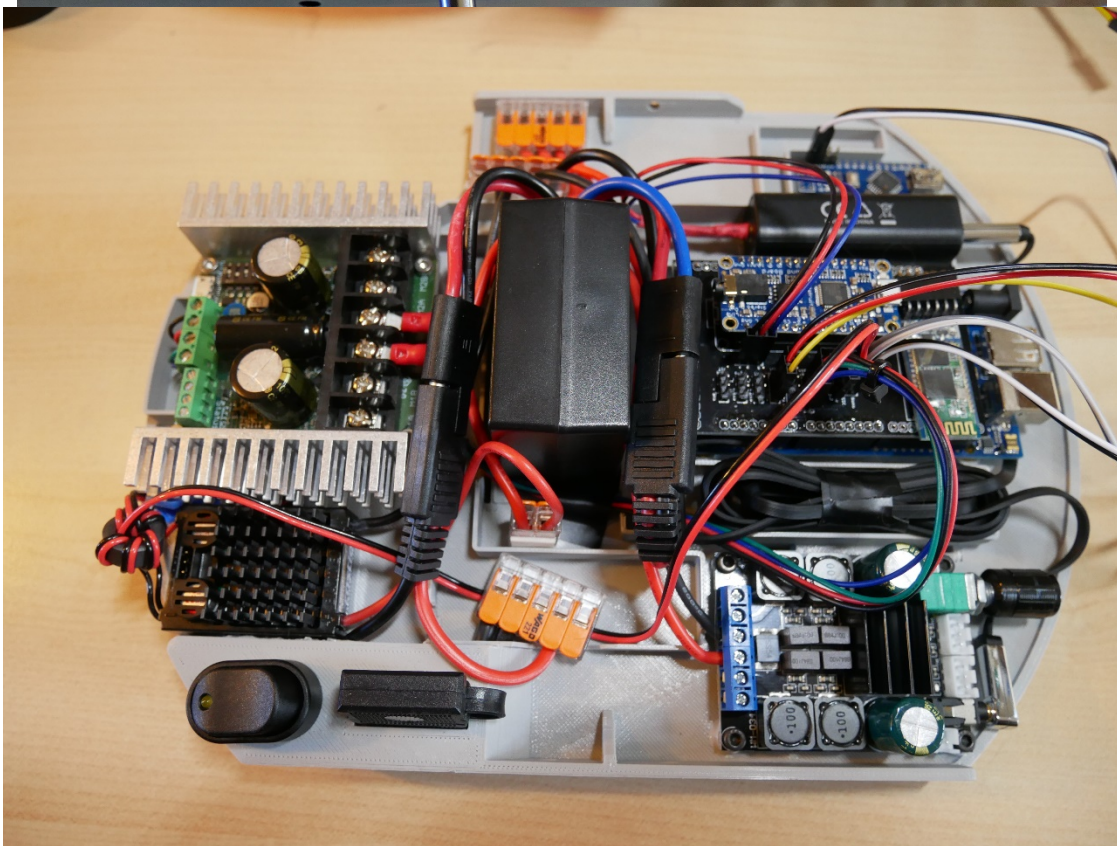

Battery Pack Assembled
Figure A16:

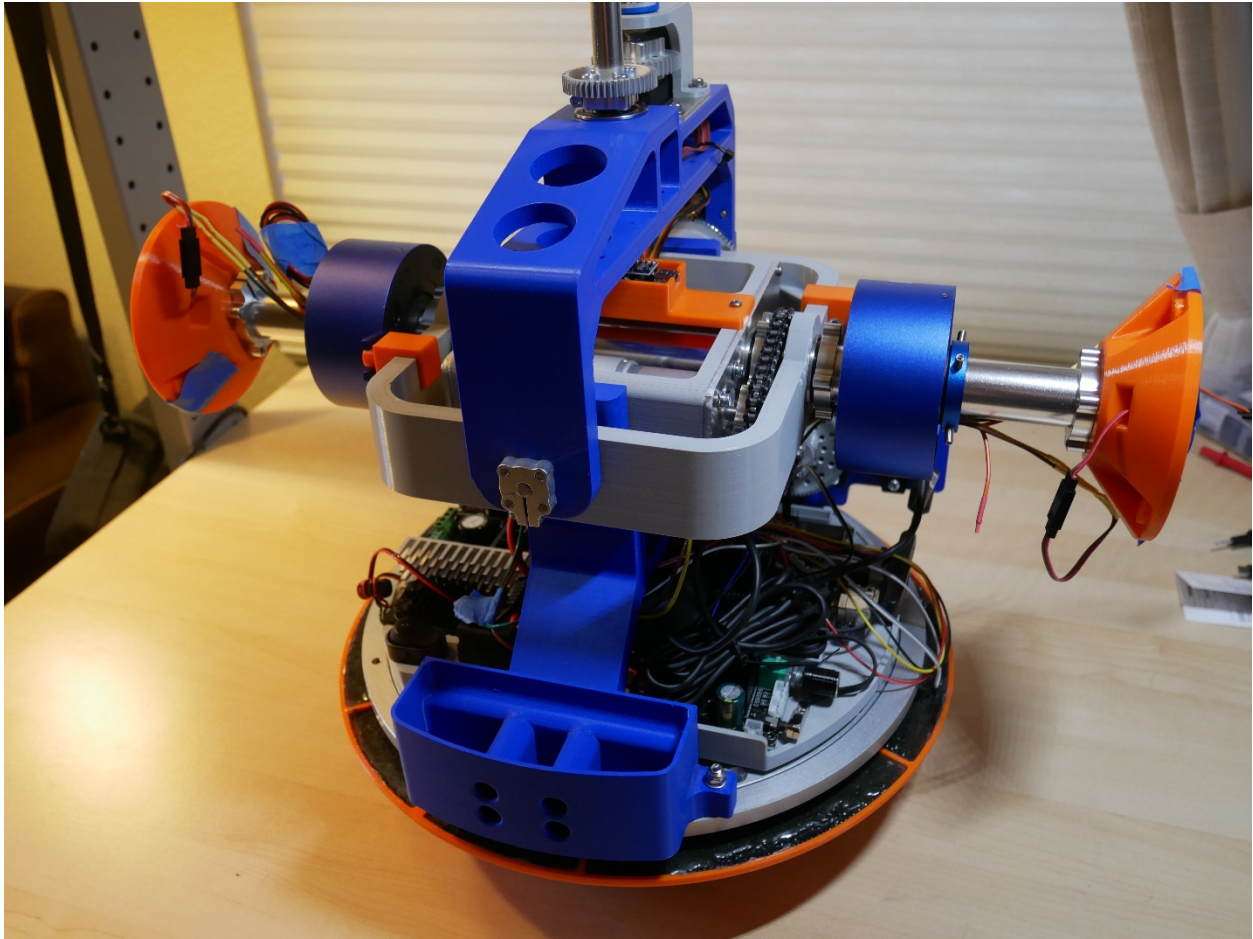

Drive Fully Assembled and Wired

Final Assembly

At this point the drive is done, but it still needs to be installed inside the skeleton and the panels need to be attached to the exterior of the skeleton. The skeleton is first filed and sanding to make sure it is at the proper diameter. If there are rough parts, the panels will not lay completely against the skeleton and gaps between the panels will form. Holes also had to be drilling out at the ends of the skeleton. The holes allow the transducers to be mounted to the panels directly giving the sounds of BB-8 more volume. Since I ran out of time to properly finish the exterior shell, the panels remain unfinished and unpainted.

Figure A17:

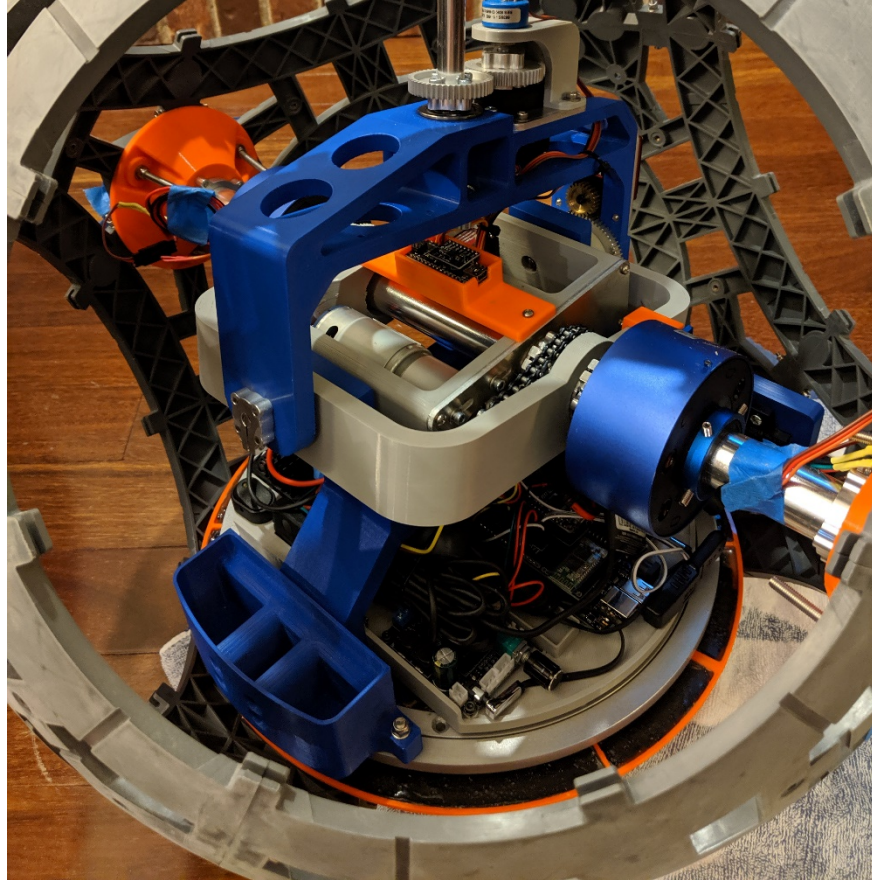
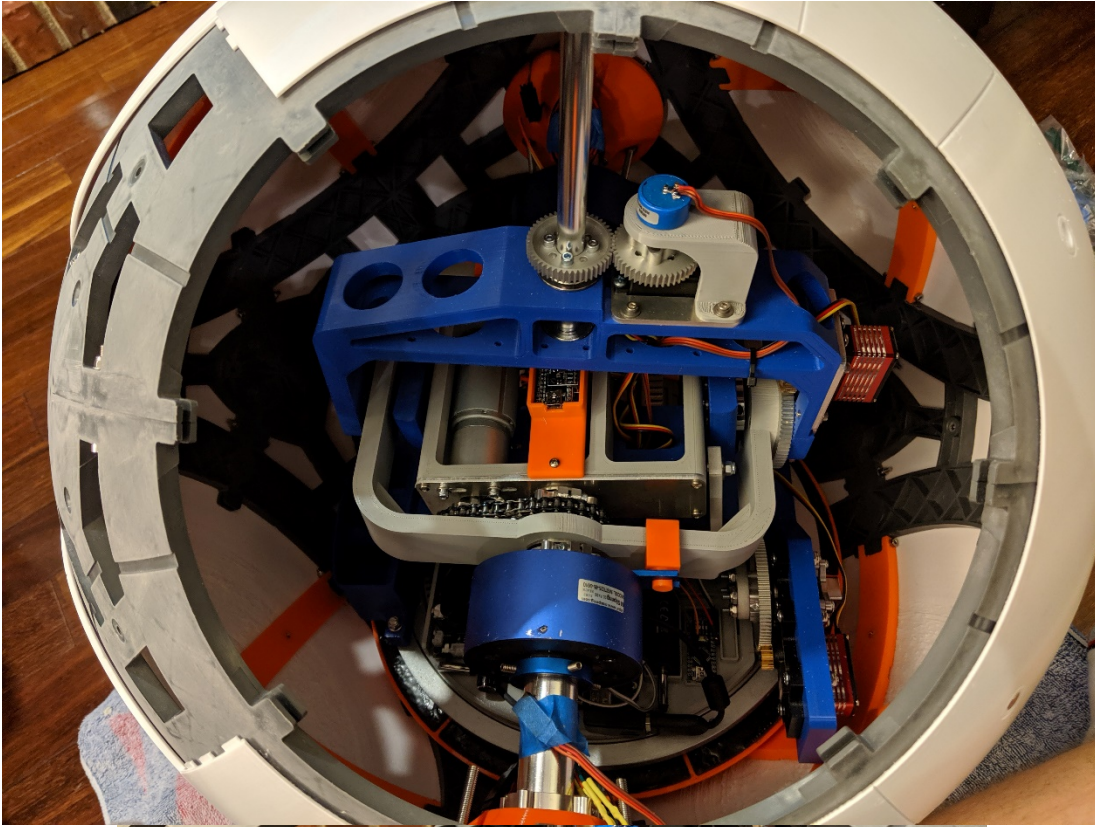

Figure A20:
BB-8 Access Panel Open

Figure A21:
Fully Assembled BB-8



Further Work

A builder is typically never completely done with their droid because there are always parts to change out or new features to add. I still need to finish the outer shell but that also involves wiring LEDs to the inside of the panels. A new quick way of charging BB-8 has also been developed and eventually I will install that in my BB-8. Parts also can wear out or break so I'm sure I will be doing a lot more work in the future on BB-8.

Appendix B(B-8): Meeting the Builders

During the past six months while working on this project, I was lucky enough to meet many of the wonderful droid builders during multiple events. They were a massive help to me and completely welcomed me into their group even though I had never met any of them in person before. Now I consider many of them to be my friends. Here are the events where I was able to meet the builders in person.

BB-AZ

While only a few weeks into the project, I was able to attend BB-AZ, which is a free workshop that Cary Christie has personally hosted for the past two years. Although I had not yet started construction of my BB-8 when I attended, I was able to talk to builders who were in the process of constructing or had already constructed their BB-8. This was a huge resource for me, and I saved countless hours from being warned about pitfalls and other difficult parts of the build process that other builders had encountered and solved.

Figure B1:
Group Photo of Builders at BB-AZ



WonderCon Anaheim 2019:

WonderCon is a convention put on by the same people who do the giant San Diego Comic Con. This con is like a mini-SDCC so it's less intense and easier to talk to people, but still a fun convention to attend. I would recommend it for anyone's first convention.

Figure B2:
R2-D2 Builders Club Booth



Star Wars Celebration Chicago 2019:

This is a massive five-day Star Wars convention that I was fortunate enough to attend this year. I was able to talk to many droid builders from all over the world and get to know the club a bit better. This was where I was able to talk to Stephane a bit more about my sensor project. I was also lucky to be able to meet Brian Herring, the puppeteer for BB-8 in the Star Wars movies. It is a massive convention though and a lot of fun to be surrounded by Star Wars fans. In 2020, Star Wars Celebration will be in Anaheim and I recommend people in the area to go for at least a day. The last day of the convention is usually quieter and more enjoyable to new convention goers.

Figure B3:

Some of the Droids Brought to Celebration
Figure B5:



Photo of Builder's R2-D2 on Convention Floor
Figure B6:



Photo of Me with Brian Herring, the Real BB-8 Puppeteer



Appendix C: Analysis of Senior Project Design

1. Summary of Functional Requirements

This project is an expansion of the Cary Christie designed BB-8 drive system that gives the drive microcontroller the ability to detect a person. The added sensors must be light enough to not affect the

stability of the head and must try to blend in with the existing design of BB-8. The dome must be able to detect a person and output a signal to the drive microcontroller so that the drive can turn the head towards the person.

2. Primary Constraints

The added sensors to BB-8 are secondary to the primary goal of having a working replica BB-8 robot so the appearance of the sensors must be able to blend in with the look of BB-8. The other main constraint is that the project must be as lightweight as possible. The club has spent much of their time and energy reducing the weight of the BB-8 dome. A heavier dome means the magnets keeping it on must be stronger. Instead of the dome gliding over the ball, the uneven surface of the ball catches the wheels of the dome and no longer makes it look like it floats on the ball. A heavier dome is also much more likely to fall off the ball and while the dome is strong, every drop onto a hard surface creates the chance of a crack or something breaking inside the dome.

3. Economic

The cost of the sensor upgrade is under \$200 and while that is not a small amount of money, most droid builders have already spent about \$3,000 constructing their BB-8 already so builders may feel it is a worthy expense. The cost of the project was paid for by myself including the cost of building BB-8. I was working a full-time job, so I was able to justify the expense as an investment in me finishing my degree. BB-8 was also a project I had been wanting to build for years so eventually I would have built one. This project was motivation for me to finally take the jump and build a droid in a short period of time. I spent around 220 hours on the entire sensor project and at least 150 hours in the construction of BB-8, not counting the weeks the 3D printer almost non-stop.

There will be no profit made from this project except for the makers of the sensors and the distributor where they are purchased from. The club does not want builders to profit from other builders so this project was not made with the intention of anyone in the club making money off of it. It is possible that Cary Christie and Stephane Beaulieu may sell a few more of their kits if people decide on the Cary drive because it has this sensor expansion. However, it's unlikely that this sensor expansion will be the determining decision in purchasing the Cary drive parts for many builders so it's unlikely that Cary or Stephane will see more sales as a result. Since the project is public, it is also free to be adapted in use by the open source Joe's Drive or by any other future BB-8 drive if another builder spends the time and effort to do so.

4. If Manufactured on a Commercial Basis:

The market for an expansion kit for the Cary Drive BB-8 is very limited. As of June of 2019, there are 110 members of the Cary V1 Drive Facebook group [18] and since you must buy the aluminum parts to have access to the Facebook group and the required files linked from there, we can assume that at most there are that many people who would potentially want to purchase an expansion kit for their Cary Drive BB-8. However, this project was intended to always be open for others to use freely. The parts are easy and simple to acquire from a single vendor (Adafruit) and the code will be available to anyone who

wants it. There are currently about 1,300 members of the Joe's Drive Facebook group [4] so I hope that my sensor project could be adapted for use for a Joe's Drive BB-8 as well. I will not profit from this project as I feel the work done is a small token of appreciation for the droid builders community and it also would violate the rules of the club. The sensors and Arduino board can be purchased for about \$175 including tax and shipping.

5. Environmental

The impact of the project mostly involves the raw materials required to make the sensors and the environmental cost to have a package shipped from New York City to California. Silicon used in the sensors requires mining [23] which greatly impacts the environment. BB-8 itself requires a large amount of plastic to produce. However, all the 3D printed pieces I made for BB-8 including the drive and outer shell were printed using the PLA type of 3D filament. This type of plastic is a bioplastic and made from biomasses such as corn starch and sugar cane. It is even biodegradable under certain conditions. [24]

6. Manufacturability

The sensors must be installed in the dome of BB-8 so it would be difficult to manufacture since each builder makes their own BB-8 dome. It is possible that I could work with the designers who created the 3D printing files of the BB-8 dome to create a version of the BB-8 dome 3D printing file that has the holes for the sensors already cutout and ready for installation. That would make things much easier for builders, but it would also mean that a builder would have to make a new BB-8 dome. Hours are spending sanding and painting the BB-8 dome so starting over may not be worth it for some people. Otherwise, the project is easy for other builders to reproduce for their own BB-8 if they so desired.

7. Sustainability

The sensors themselves will not wear out or need to be maintained. However, typically a builder continues to upgrade or change out parts so these sensors may need to be installed, uninstalled, and reinstalled again into a new dome. Even while working on this project, the design of my dome rotation has become outdated and the rotation mechanism has been upgraded to be lighter and more stable. I will want to upgrade to this style of dome rotation eventually and that will mean I will have to change how the wires lay inside the dome. It is possible that new revisions to the dome itself come out or my dome may fall off the ball one too many times and a crack could form. Cracks are sometimes reparable, but sometimes would require a fresh dome to be made.

Future production issues of both the BB-8 drive design and the parts themselves are a possibility. This sensor project also is based on the Cary V1 Drive and while Cary Christie has made no indication that he will stop selling parts for the drive, it is possible that eventually he will stop making them at some point. The sensors would then have to be adapted for whatever the current drive design is. Electronic parts go out of production and these sensors are no exception, or updated versions of them may be produced instead. Future versions of these parts should hopefully work but there is no guarantee that they will still be appropriate for installing in a BB-8.

8. Ethical

The main ethical concerns with this project are related to the entire droid builders community. The community exists with the support of Disney because the club agrees to follow the guidelines that Disney has set up. When in public, BB-8 must act like BB-8 and not behave out of character. BB-8 cannot play music for example even though it is easily capable of doing so. BB-8 must also not endorse another company or product, which means I couldn't attach a baseball team's hat to his dome out in public or have him pose for pictures in front of company logos. I cannot also receive any money for bringing BB-8 to an event or have someone advertise an appearance by BB-8. By being part of the droid community, I agree to follow these guidelines set by Disney even though the public may not understand them. The design and likeness of BB-8 is their property and the community is very careful to respect that because it depends on Disney allowing designs to be shared within the club. Not following these guidelines jeopardizes the community and would open myself up to legal action by Disney.

One concern also with a people detection system is the fact that the height of BB-8 makes any sort of system that could capture and process images completely out of the question. The height and angle of the front of BB-8 would have the likelihood of capturing illegal images of people if such a system were used. My front sensor uses very low-resolution IR sensitive thermopiles and my project has no way of recording any data so there is no danger of it being misused.

This project is available to everyone and does not discriminate. Although I built this project with members of the club in mind, access to my project is not restricted to just club members and is available to anyone. The club limits their designs to club members out of respect to Disney's licensed property, but my sensor project does not reproduce anything licensed by Disney. Everyone is welcome to join a builders club and all that is required is to give a short explanation of why you want to join when you register for an account, mostly to make sure you aren't a bot. No real approval is required to be a member and everyone is welcome.

9. Health and Safety

The sensors in this project are only in use when BB-8 is stationary and it has no control over the moving the ball itself. Only the head can spin but this does not pose any danger to the public. Since the dome is held on by magnets, if the dome were to try to spin while a person was touching it with force, the dome would pop off the ball instead of hurting the person. BB-8 does not move autonomously so there is no danger of it making contact with a child or adult. The person with the controller is the only thing capable of moving BB-8 in a dangerous way and this project does not change that. Also, the BB-8 operator always wears a remote kill switch when operating BB-8 in the very unlikely event that they lose control over BB-8.

There is some safety risk when installing these sensors as I used a power drill to make the holes in the dome of BB-8. However, each builder has already done plenty of drilling and used other workshop tools by the time they have finished making a BB-8 so this is very little additional risk when installing the sensors. The club reminds everyone to use the proper safety protection when doing any build work.

10. Social and Political

This project expands on the countless hours others have spent developing a working BB-8 droid and the droid builders themselves are the direct stakeholders in this project. It is a collaborative effort required by everyone for part development and to help new members build their own droid. I hope this project benefits the club and its members, and can help guide anyone looking to follow from avoiding some pitfalls in making a sensor project for BB-8 or another droid. I open the project up completely to all builders to use or expand however they wish.

The people BB-8 meets in public are always smiling and enjoy seeing BB-8 up close and in action and they are the indirect stakeholders of this project. I was able to drive another builder's BB-8 at the Star Wars Celebration convention for about an hour and people would not stop asking to take photos with BB-8. The builder of this BB-8 said it took him three hours to get from one end of the convention floor to the other because BB-8 was almost always being stopped for pictures and for interacting with people. These sensors make BB-8 a little more lifelike when interacting with people and can help people forget that the BB-8 they are seeing is essentially a fancy remote-controlled toy.

BB-8 also is a huge outreach for getting children interested in STEM fields at a young age. They already know BB-8 from the movies but find it cool that they can be built in real life as well. Even in the short time I've been building a BB-8, I have already been invited to present BB-8 at a STEM workshop at a local school. I am already used to interacting with young children at work so I know I would enjoy sparking the love of engineering in kids.

11. Development

This project involves more than just my sensors and required me to construct a fully, working BB-8, which I had never done before. I was familiar with most of the tools used but there were some new skills I learned like tapping holes in the aluminum pieces for screws. The project gave me an appreciation of the different fields of engineering required to build a working BB-8 and how each one is essential. I thought about how each component is used in BB-8 and why it was selected. As a result, I learned a lot more about motor and servo controllers than I had known before.

I also bought a 3D printer a few months before starting BB-8 so I was very inexperienced with 3D printing when I started. I had to learn how to troubleshoot issues with the 3D printer and know what settings to use for my printer for the parts to come out well. My first recommendation for anyone who wants to build a BB-8 is to make sure they have a good working 3D printer that they know how to use and troubleshoot. The circle shell pieces of BB-8 alone took 55 hours each, and I had to print six of them. Some of the pieces used in the drive also took almost two days to print. I had issues at times and had many failed prints, but by the end, my printer was a workhorse and was reliably making these multi-day prints successfully.

I also had to learn more about Arduino and how to code for it. I had done some simple projects before, but I had never used I2C or Software Serial with Arduino so I had to spend time researching how to implement that.