

# Paint Line Test Stand: Final Design Review



**Sponsored by Nigel Abraham**

## **Project Advisor**

Eltahry Elghandour      [eelghand@calpoly.edu](mailto:eelghand@calpoly.edu)

## **Design Team**

Sidney Wong      [swong58@calpoly.edu](mailto:swong58@calpoly.edu)

Taylor Best      [tabest@calpoly.edu](mailto:tabest@calpoly.edu)

Aaron Fisher      [aafisher@calpoly.edu](mailto:aafisher@calpoly.edu)

December 6, 2018

## Statement of Disclaimer

Since this project is a result of a class assignment, it has been graded and accepted as fulfillment of the course requirements. Acceptance does not imply technical accuracy or reliability. Any use of information in this report is done at the risk of the user. These risks may include catastrophic failure of the device or infringement of patent or copyright laws. California Polytechnic State University at San Luis Obispo and its staff cannot be held liable for any use or misuse of the project.

## **Table of Contents:**

Executive Summary.....	1
Introduction.....	2
Background.....	2
Customer Needs.....	2
Existing Products.....	3
Other Research.....	6
Objectives.....	7
Problem Statement.....	7
Needs/Wants Discussion.....	7
Boundary Diagram.....	8
Quality Function Deployment Process.....	9
Specifications.....	9
Concept Design Development.....	10
Concept Development Process and Results.....	10
Concept Selection Process and Results.....	18
Concept Designs.....	21
Selected Concept.....	24
Concept Functionality.....	25
Risks and Unknowns.....	25
Final Design.....	25
Design Updated.....	26
Overall Description and Layout.....	27
Final Design.....	27
Detailed Design Description.....	28
Analysis Description and Results.....	31
Cost Analysis.....	33
Choices of material/geometry/components.....	35
Safety and Maintenance/Replacement.....	35

Manufacturing.....	37
Procurement.....	37
Manufacturing Plan.....	37
Challenges.....	40
Future Recommendations.....	40
Design Verification Plan.....	41
Testing Plan.....	41
Testing Results.....	42
Project Management.....	43
Overall Design Process.....	43
Timeline.....	44
Special Techniques.....	45
Conclusion.....	46
References.....	47
Appendix A: QFD House of Quality.....	48
Appendix B: Decision Matrices.....	49
Appendix C: Final Analyses/Testing Details.....	51
Appendix D: Final Analyses.....	63
Appendix E: Safety Hazard.....	76
Appendix F: Gantt Chart.....	78
Appendix G: Complete Drawings Package.....	79

## **List of Figures:**

2.1. SolidWorks model of the Pac-Man device connected to a motor.....	3
2.2. Model 24-SL-020 motor.....	4
2.3. L200 Lab Jack.....	4
2.4. Model WINL47C-10/1-H318.....	5
2.5 Timing belt and pulley assembly.....	5
2.6. Chain and sprocket system for power transmission.....	6
2.7. Sketch of drive block lifting system.....	7
3.1. Boundary diagram displaying the focus of this project.....	8
4.3. Parallel shaft layout with belt and pulley.....	12
4.4. Parallel shaft layout with chain and sprocket.....	12
4.5. Perpendicular shaft layout with bevel gears.....	13
4.6. Perpendicular shaft layout with a worm gear.....	13
4.7. Vertically adjustable table that uses telescopic hydraulic columns.....	14
4.8. Vertically adjustable table that uses folding scissor links.....	14
4.9. Pac-Man device is driven by a worm gear drivetrain.....	17
4.10. Pac-Man device is driven by a belt and pulley drivetrain.....	17
4.11. Pac-Man device is driven by a chain and sprocket system.....	18
4.12. Concept 1.....	22
4.13. Concept 2.....	23
4.14. Cardboard prototype representing concept 2.....	24
4.15. SolidWorks model representing concept 2.....	24
5.1. Updated design.....	26
5.2. Updated assembly view.....	27
5.3 Final Design View.....	28
5.4. Speed – Torque data.....	29
5.5 Control Panel for motor.....	30
5.6 Taper Lock Bushing for Disk/Shaft.....	31
5.7. Bending stress notch radius.....	32
5.8 Torsional Shear stress notch radius.....	32

6.1. Disk Machining Process.....	37
6.2. Pac-Man housing manufacturing process.....	38
6.3. Speed Control Panel Used.....	38
6.4. Shaft Support Legs After Assembly.....	39
6.5. Baseplate Drilling Process.....	39
6.6. Acrylic Housing Manufacturing.....	40

**List of Tables:**

3.1. Customer Needs and Wants.....	8
3.2. Summary of Specifications and Targets.....	9
4.1. Reduced Morphological Table with the Most Feasible ideas.....	16
4.2. Reduced Morphological Table.....	19
5.1. Bill of Materials.....	33
8.1. Quarterly Key Deliverables.....	44
8.2. Available Project Resources.....	45

## **Executive Summary:**

The roofing manufacturer GAF located in Shafter, CA is in pursuit of a mechanism with the ability to improve the quality of paint lining applied on a dynamic roll of roofing shingles. The mechanism must consist of an alignment system along which a paint line applicator can be adjusted in the vertical direction and operate at a certain range of speeds. Other requirements for the mechanism demand that it is feasibly portable, reasonably durable, capable of accurate alignment, mountable to the ground, and within a budget of \$15,000. With the customer's design requirements established and understood, a one-year project has been outlined with details on how the objectives assigned to the Cal Poly 2018 senior project team will be satisfied. The first quarter was spent researching, brainstorming ideas, drafting a Quality Functional Deployment chart and producing different design concepts from which a final design would be made. After finalizing the design concept, it was presented to GAF for evaluation where approval and feedback were provided. After evaluating the feedback from GAF, the team proceeded with the project doing an Interim Design review to finalize the design by deciding which parts of the design concept can remain in use, and identifying parts that needed to be changed or added to. Some of the original structural components were modified in an effort to help improve the quality of paint application. Additionally, the Pac-Man device is driven by a belt and pulley coupled to a motor while maintaining the use of a mill table and hydraulic scissor link table for horizontal and vertical position adjustability respectfully. Throughout the second quarter the team was tasked with conducting a critical design review which involved calculations needed for design verification. Also the majority of the quarter was spent on planning for the manufacturing and testing part of the following quarter. The third and final quarter was spent doing a final design review where the team concludes the project with the last round of design modifications, followed by a hardware and safety demo. From there the project was assembled and tested after all parts were ordered, manufactured, and assembled. This was then followed by the project exposition where it has been presented and shown to viewers what it was designed for and how it operates.

## **Chapter 1: Introduction**

GAF, the largest roofing manufacturer in the United States, has a roofing shingle manufacturing plant located in Shafter, CA. Currently at one stage along the production line, a small white line is applied to the sheets of shingles as they are manufactured. This is done for four sections spaced apart from one another on the same sheet of roofing shingles. This line is to assist construction workers in locating where they should nail the shingles down. Currently, the line that is applied is too faint and is often misaligned. A 2017 senior project team from Cal Poly San Luis Obispo was tasked with designing a new paint line applicator. The design that was created from this project has been named the Pac-Man applicator due to its housing shape. In order to implement this design on the GAF shingle manufacturing line, the 2018 senior project team, consisting of Taylor Best, Aaron Fisher, and Sidney Wong, is tasked with designing an assembly that incorporates the Pac-Man applicator, can be vertically adjusted and fixed to the ground. A drivetrain must be designed and installed between the selected motor and the Pac-Man device to ensure that the disk is rotating at the correct angular velocity. With this project completed, the GAF team will be closer to replacing their current paint application system.

## **Chapter 2: Background**

It is critical in the design process that the team has a clear understanding of what requirements need to be met and how one will go about meeting said requirements. The key approaches to this involve maintaining communication with the customer and making inquiries about the project to get information about the customer's needs. Such needs may include: constraints, the project's operating environment, important dimensions, and other features that must be considered in the design. Additionally, research will play an important role in helping the team decide how to proceed with the design process based on what the customer requires. By looking at existing products that are similar to the application of the team's project, the same methods found in a similar product could help generate new ideas leading to an approach that can be used to finalize a prototype.

### **2.1 Customer Needs**

In order to better understand the goals of the design sought by GAF, the team conducted an in-person interview with Ricardo Quiroz at the GAF plant in Shafter, CA followed by a tour of the roofing shingle manufacturing area. Prior to the meeting, the team drafted some questions in preparation for the project development pertaining to constraints that had to be followed. This information consisted of details regarding the previous project that the team is tasked with continuing and further clarification on the needs of GAF. During the in-person interview, the team was shown the current method used to apply paint lines on the roofing shingles. They were also shown how the previous senior project team approached designing and testing the Pac-Man device which is shown below in Figure 2.1. In that discussion, the team learned that the continuation of the project involved several key aspects: designing a drivetrain to control the speed at the edge of the paint application disk and a mechanism to allow vertical adjustability. This is for one single assembly and the design must be made so that there is allowable room for a certain number of units to be placed side by side from one another.



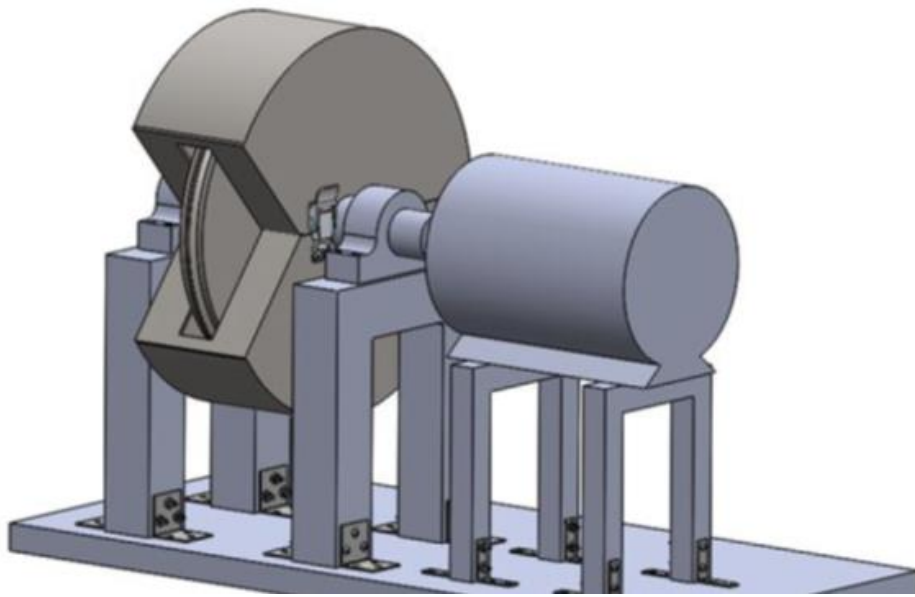

Figure 2.1. SolidWorks model of the Pac-Man device connected to a motor.

## 2.2 Existing Products

With the objectives understood, the team proceeded to research how a vertical adjustor could be feasibly incorporated into the fixture by comparing existing products with similar functions. From there, research was done on applications with drivetrains on a variety of different machines. The following products concerning vertical adjustor research include a spiral scissor mechanical lift used for powered vertical actuation and a linear translation stage used for manual vertical actuation. From there, research was done on drivetrains to help determine which choice of a drivetrain would be best for transmitting power from the motor to the Pac-Man device while controlling the speed of the disk.

### *Vertical Adjustment -*

One certainty is that the Pac-Man device may be repeatedly adjusted in the vertical direction. This may occur on some occasions whether it is for finding the proper placement of the disk, maintenance, or temporary removal of the device. The Model 24-SL-020 spiral lift table shown below in Figure 2.2 is designed for periodic repeated use. The table can descend to as low as 11 inches from the ground and can ascend to as high as 71 inches. It has a table area of 95 by 32 inches and is designed to lift objects with a capacity of up to 2000 lbs. According to the manufacturer of this device, it can provide a high degree of precision with its vertical positioning and can be used in single or multiple columns to vary load capacity [1]. A motor located at the base of the actuator can be programmed to predetermined work elevations by the user's choice. The user can program those settings using a transducer, encoder, or a PLC motor controller. The dimensions can be customized if needed and the price of this device, in particular costs around \$10,000. This price may be changed depending on the parameters that are modified.



Figure 2.2. Model 24-SL-020 motor driven spiral lift table with vertical adjustment when the helical column is rotated to change the table's height.

Figure 2.3 shown below is an image of another product known as the L200 Lab Jack. This product is also vertically adjustable but is controlled manually rather than electronically through a microcontroller. According to the manufacturer, a turning knob that is connected to a lead screw is used to close the angle between the opposing pairs of supporting struts. The axles and connecting rods are made of stainless steel and allow for the jack to hold loads of up to 75 lbs. for a smooth elevation gain over its entire range. The top and bottom plates each have an array of nineteen 1/4"-20 (M6) tapped mounting holes on 1" centers [2]. It has a 4 inch by 7 inch mounting surface and can be ascended to approximately 4.5 inches from the ground. Given its dimensions and other parameters, this mechanism in particular costs \$609.96.



Figure 2.3. L200 Lab Jack that is manually driven with the turn of a knob to change the table height vertically.

## *Drive Trains -*

In researching drivetrains, the goal was to find one that is a reasonable price, lightweight, and meets the design needs. Figure 2.4 shown below is a Model WINL47C-10/1-H318 gear reducer coupled with a 75 HP motor. It has a weight of 390 lbs., a cost of \$1,587, a gear ratio of 10:1, and has low vibration and temperature specifications [3]. This would be an item worth considering since, at the moment, there is a large amount of vibration while the device is running. Therefore, vibration control may be necessary. The gear box is designed to allow a range of speed control with the use of helical gears and a motor speed of 1800 RPM.



Figure 2.4. Model WINL47C-10/1-H318 gear reducer coupled with a Hyundai Crown Triton motor.

Another option that was researched for a drivetrain was using a timing belt that could be coupled between the motor and the Pac-Man device. Typically, these are used in car engines for synchronizing the rotation of the crankshaft and camshaft of the engine for proper timing of valve function [4]. For this project, a timing belt and pulley drivetrain is the ideal choice as opposed to a standard belt and pulley that does not use teeth. Belt drivetrains are known to be able to operate in dirty environments and are very inexpensive to maintain or replace. Additionally, a timing belt is less likely to slip than a standard belt and therefore yields a better rating for efficiency. The downside to using a belt, however, is that they need to be tensioned correctly and over time, they continue to elongate. As a result, they would require further tensioning which may continue to the point where the belt begins to fail. Figure 2.5 shown below shows the belt type that could be used as a drivetrain.



Figure 2.5. Timing belt and pulley assembly with teeth shown on both the belt and pulley.

The last idea for a drive train considered by the team is incorporating a chain and sprocket system. This is a commonly used drivetrain for many applications and it functions much like the belt and pulley system. Unlike belts however, they can be designed to have the multiple speed reduction ratios by incorporating cassette sprockets. One limitation the team would face with this choice is that it would only be applicable if the shafts were oriented in a parallel configuration. Because this drivetrain can operate in dirty environments, it is worth considering since the project will be used in a dirty environment. When it comes to maintenance, this choice is the most demanding because lubrication is needed to maintain optimum performance and if not tensioned properly, it may not last as long as its rated life [5].



Figure 2.6. Chain and sprocket system for power transmission.

### **2.3 Other Research**

To further generate ideas, the team conducted patent research concerning mechanisms similar to what needs to be designed for the project using the United States Patent and Trademark Office website as the search source.

#### Patent Application Information:

Date published: June 15, 2017

Investors: Long; William T, Krueger; David E, Paddock; Ryan Evan

Patent Number: 9637361

Shown below in Figure 2.7 is an assembly that uses a vertical jack connected to members which move along a railing alignment system. In this assembly, the members of the vertical jack are made of an outer sleeve and a sliding inner portion that has the capability of being vertically driven along the alignment of the rails. The drive system uses a jack screw and a drive block on which the object of interest could be ascended or descended. The jack members and the entire structure is stabilized with the use of diagonal cross bracing [6].

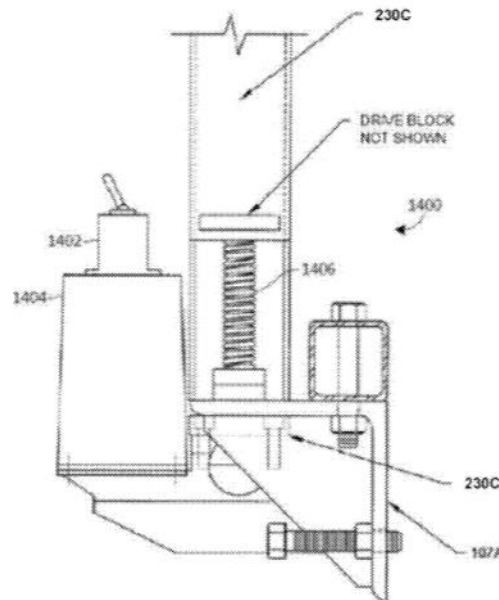

Figure 2.7. Sketch of the lifting system where a drive block constrained by railing is driven vertically by a jack screw.

### **Chapter 3: Objectives**

After sufficient background research was conducted, the team's focus shifted to accurately defining the problems to be solved. To do so, a problem statement was written to act as a broad summary of the requirements which are important to the customer. From there, the specifications desired by the customer were further examined. The needs and wants were separated and their importance relative to one another were surveyed. This exercise allowed the team to identify specifications fundamental to the project's success. Next, the project was analyzed using the QFD process. This method requires the designer to closely examine who the customers are, what they want, and which specifications will most effectively solve the problems presented. Target weights are assigned to the various categories to help identify which factors should be the group's main focuses.

#### **3.1 Problem Statement**

The roofing shingle manufacturer, GAF, currently needs an assembly capable of integrating a previous senior project's paint applicator design. This assembly must be height adjustable and capable of supporting the design's current horizontal adjustability. A drivetrain between the motor and Pac-Man device must also be incorporated to ensure that the paint application wheel travels at the optimum speed while remaining spatially conservative.

#### **3.2 Needs/Wants Discussion**

After examining the previous senior project group's work and meeting with the GAF professionals, the desired characteristics expected to accompany the new design were identified. These features were separated into wants and needs. The needs represent characteristics that are vital to the product's functionality or deemed nonnegotiable by the customer. On the other hand,

wants are traits that would preferably, but not necessarily, be included in the final design. The distribution between the wants and needs found in this project can be seen in Table 3.1. As a result of this exercise, the team has determined four characteristics to be in the wants category. First, the budget presented to the team was set at \$15,000. This metric is placed in the want category because it is not expected that the project will reach anywhere near this value. Second, the GAF team expressed that in the future more Pac-Man devices may be added alongside one another. To promote this possible integration, the system will be designed to be spatially conservative. This will allow for more devices to be placed in series. Finally, the last two wants were determined to be designing the system to be easily maintained and to have a prolonged life. While these specifications do not directly impact the functionality of the device, they are certainly notable points to be considered.

Table 3.1. Customer needs and wants.

Customer Needs	Customer Wants
Horizontal Adjustability	Budget of \$15,000
Vertical Adjustability	Spatially Conservative
Disk Travels at Correct Speed	Ease of Maintenance
Portability	Prolonged Life
Safety	-

### 3.2 Boundary Diagram

The boundary diagram below shows the physical extent of the current project scope. Since the project outlined thus far only indicates the need for a vertically adjustable stand and drivetrain, there are only two areas marked and much of the previous Pac-Man design is excluded. All that is enclosed in these areas is the mount which will support the assembly and the connection between the motor and Pac-Man device.

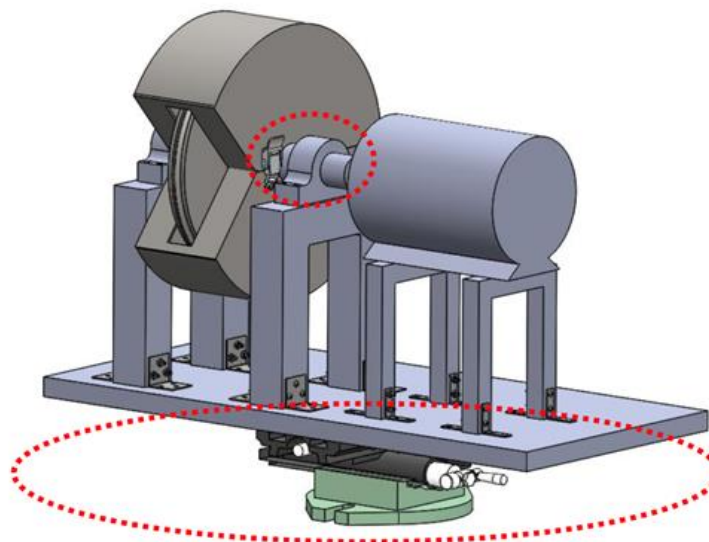

Figure 3.1. Boundary diagram displaying the focus of this project.

### 3.3 Quality Function Deployment Process

The QFD process is a method utilized by designers to accurately identify customers and weigh their requirements. First, the actual customers were defined to be the GAF associates and the construction workers who install the roofing shingles. From there, the project's main concerns were listed as they were communicated to the team through the initial presentation and on-site meeting. These needs were ranked on a scale of 1 to 5 where a need with a level 5 indicates that it is of greatest importance. The project's specifications were then determined and placed in the vertical columns at the top of the chart. These specifications were compared to each design requirement to determine how effective each would be at meeting the needs. Each of these relationships were rated as being strong, medium, or weak. This helps identify which specifications will be the most effective at solving the problem and which specifications are irrelevant. At this point, targets were also assigned to each applicable specification to provide the team with helpful goals for each design decision. Lastly, some existing solutions were compared to see which methods proved to be most effective and to identify where they could be improved. The QFD process helped the team identify which specifications should be their lead concerns and taken into consideration as the design process moves forward. The QFD house of quality is attached in Appendix A.

### 3.4 Specifications

Table 3.2. Summary of specifications and targets.

Spec #	Parameter Description	Target	Tolerance	Risk
1	Drivetrain Design	20 lbs.	+/- 10 lbs.	M
2	Method of Transportation	Able by Forklift	N/A	M
3	Method of Adjustment	2 ft. of Range	+/- 1 ft.	H
4	Base Structure	6 ft <sup>2</sup>	MAX	M
5	Cost	\$15,000	MAX	H

Table 3.2 above depicts the five specifications that have been awarded target values. These target values serve as goals which the team will aim to meet to produce a favorable product. For example, the drivetrain will need to be capable of taking power from the motor and turning the paint application wheel at the correct speed. The target for this specification is for the final drivetrain assembly to weigh about 20 pounds or less. The final product must also be designed with its potential relocation in mind. The target for this consideration is to make an assembly that can be easily transported by a forklift or humans. Similarly, the team must also ensure that the wheel is able to reach the shingles in the correct location on the cooling roll. For this reason, a target for approximately 2 feet of range will be set for the vertical adjustability. The base structure must also be closely monitored. If this design proves to be successful, multiple Pac-Man applicators will be added to the line next to each other. Due to limited space, the team has assigned a target of 6 square feet for the resulting base footprint. Lastly, the cost of the finished assembly is not to exceed \$15,000. The total amount spent on the project will be closely scrutinized to ensure this result.

## **Chapter 4: Concept Design Development**

### **4.1 Concept Development Process and Results**

#### **Brain Sketching:**

The team initiated the concept design development by generating a variety of ideas through two types of brainstorming sessions during group meetings. The first round of ideas generated by the team were acquired in a brainstorming session using a technique known as brain-sketching. Brain-sketching involves the team members each generating their own ideas, combining them, and then giving feedback to finalize a design idea. Before brain sketching is conducted the team first establishes clear understanding of the problem statement defined and the design requirements that are to be satisfied. From there brain sketching commences with a set timer allowing the team five minutes to individually sketch the ideas they think would best serve meeting the design requirements. After the first five minutes, the team passes their sketches to the member next to them where they are then allowed another five minutes to interpret the sketches and impose comments to point out possible mistakes or improvements. This step is repeated until all members have seen each sketch where all have been interpreted and been given feedback. This is a valuable technique to incorporate into the design process because it allows all team members to present their ideas visually, and then to clear out any confusion verbally should there be no clear understanding at first. It also allows the team to narrow the ideas down to the most feasible possibilities and then select the final idea upon agreement.

#### **Primary Components:**

After reviewing the problem statement, it is recognized that the overall design's primary components may consist of a reducer to be coupled between the motor and the Pac-man device. All of these components may be placed on mechanical stands. These three items are defined as the primary components since the primary goal is to have the edge of the disk rotate with a certain angular velocity. The first brain-sketching session for this part of the design process only focused on how the primary components would be configured. All the team members sketched the same two possibilities for an assembly layout. One consisted of the Pac-Man device's shaft connecting all components in line as shown in Figure 4.1. The other layout had the motor shaft perpendicular to the reducer shaft as shown in Figure 4.2. Note that these chosen layouts shown in Figures 4.1 and 4.2 are meant to represent shaft alignment and do not represent the actual placement of each primary component as they can be done in a variety of ways for each shaft alignment. For instance, the motor in the parallel alignment diagram, Figure 4.1, could be flipped to sit behind the Pan-Man device and reduce the width of the overall base.



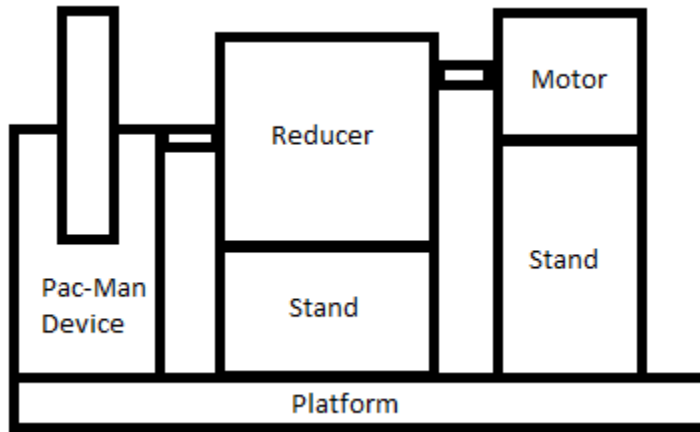

Figure 4.1. Layout of the motor shaft and the Pac-Man device shaft where they will remain in a parallel alignment to one another.

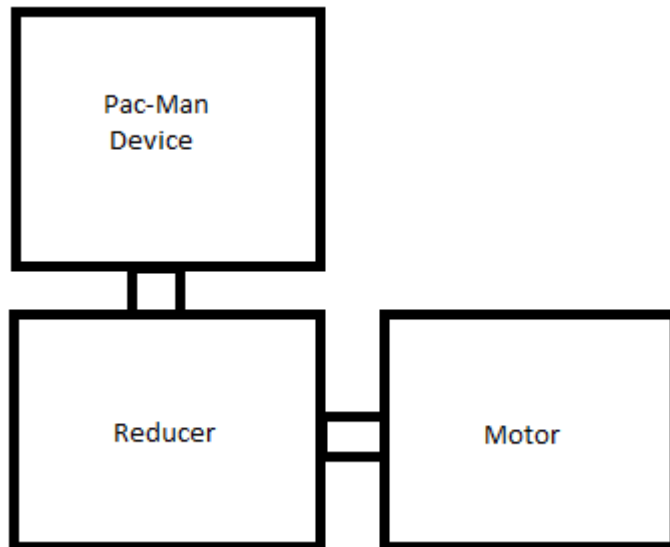

Figure 4.2. Layout of the motor shaft and the Pac-Man Device shaft where the shafts will remain in a perpendicular alignment.

#### *Parallel Shaft Configurations -*

With the two possible configurations defined, the team then conducted a second brain sketching session to generate ideas on how the reducer and motor would be placed as well as what type of drivetrain could be used to connect them. The session focused on the possible layouts that could be used for input and output shafts configured in a parallel arrangement. Figures 4.3 and 4.4 shown below represent a possible parallel shaft configuration where the motor is placed behind the Pac-Man device and coupled by either a belt or chain respectively.

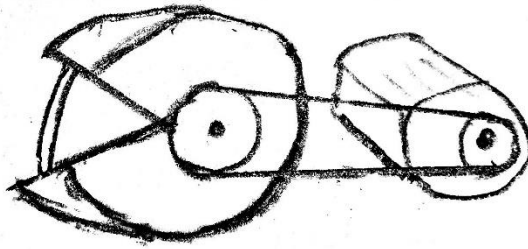

Figure 4.3. Parallel shaft layout where the input and output shafts are coupled between the reducer which consists of a belt and pulley drivetrain.

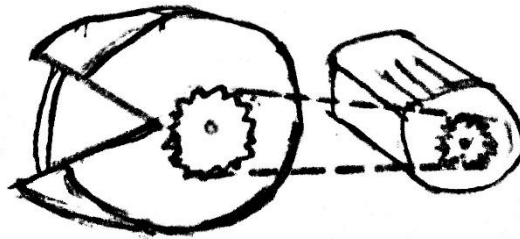

Figure 4.4. Parallel shaft layout where the input and output shafts are coupled between the reducer which consists of a chain and sprocket drivetrain.

### *Perpendicular Shaft Configurations -*

The third brain-sketching session was conducted in the same manner as before but with the focus on the perpendicular arrangement between the shafts. Given the nature of energy transmission between perpendicular shafts, the sketches drawn during this session both involve the use of gears. Figures 4.5 and 4.6 below show the sketches obtained where perpendicular shafts are driven using bevel gears and a worm gear respectively.

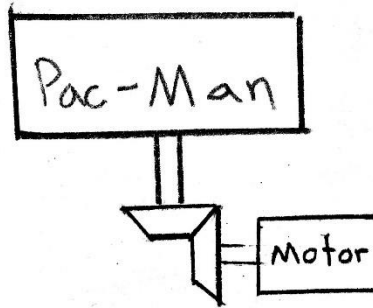

Figure 4.5. Perpendicular shaft layout where the input and output shafts are coupled between the reducer which consists of a bevel gear drivetrain.

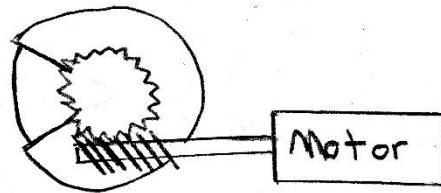

Figure 4.6. Perpendicular shaft layout where the input and output shafts are coupled between the reducer which consists of a worm gear drivetrain.

Secondary Components:

The fourth round of brain-sketching was done to generate ideas for the secondary components of the assembly. This consists of the type of vertical adjuster that is to be incorporated under the assembly. After all of the research done on tables with vertical adjustability, the team focused on selecting tables that were capable of lifting using either hydraulic columns or scissor links. Upon completion of the brain-sketching session, the team sketched a hydraulic column lifting table and a scissor link table as shown in Figures 4.7 and 4.8, respectively.

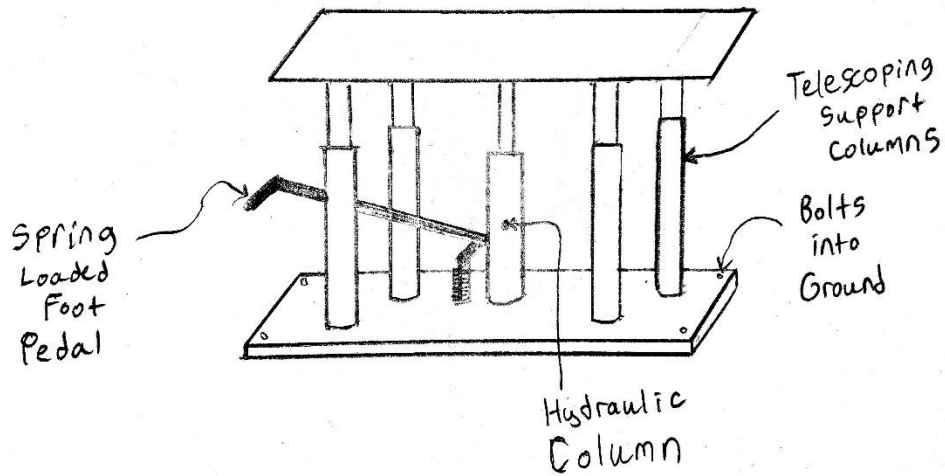

Figure 4.7. Vertically adjustable table that uses telescopic hydraulic columns that change the height of the table.

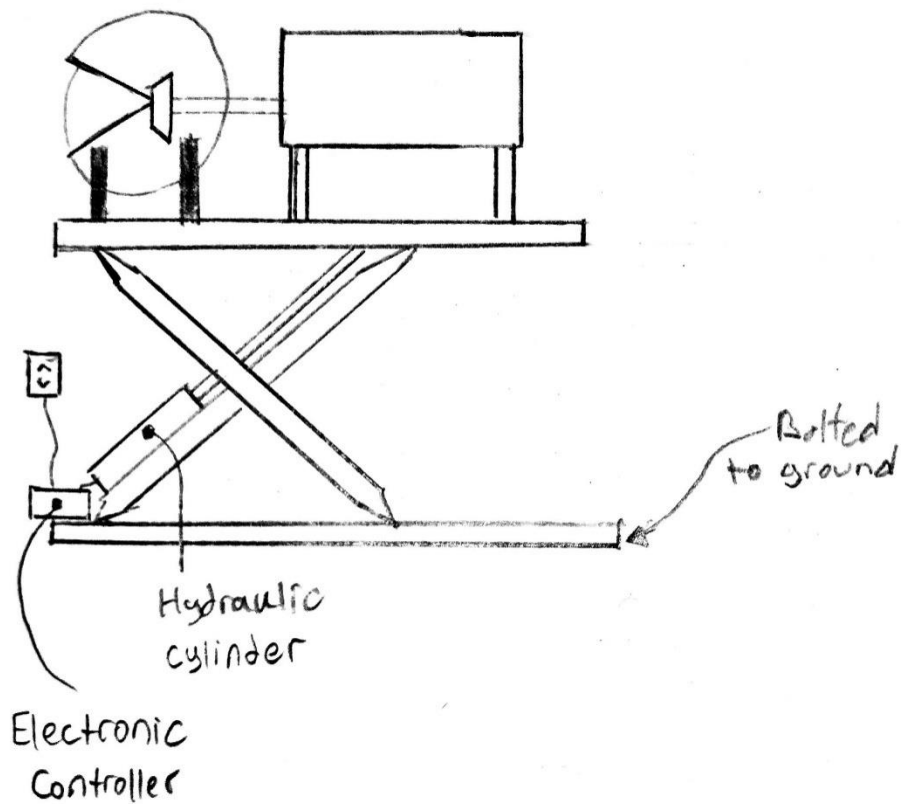

Figure 4.8. Vertically adjustable table that uses folding scissor links to change the table height powered by an electronic controller.

## S.C.A.M.P.E.R.:

After the final round of brain-sketching, the team then proceeded to the next brainstorming session where a technique known as S.C.A.M.P.E.R. was incorporated. This technique is used to evaluate existing products on which the basis of the design project could be established. From these products, certain parts can be altered or kept to be used in the design. The S.C.A.M.P.E.R. session was primarily focused on the main functions of the overall assembly above the vertically adjustable table. This includes the horizontal adjustability and the drivetrain for the Pac-Man device. The name of this technique is an acronym that consists of the following words representing each of its approaches: substitute, combine, adapt, modify, put to another use, eliminate, and reverse. However, given the circumstances of this design project and the requirements tasked to the team, the last four approaches in S.C.A.M.P.E.R. were not applicable to this project.

The Pac-Man device is the first of its kind. There are no similar products that match it, though there are other methods that match what the Pac-Man device is designed for. As a result, when considering the "modify" and "put to another use" approaches, the team is not able to find changeable products with one function that could be used for a different function for the Pac-Man device. There is nothing to eliminate from the Pac-Man device since this is the device on which S.C.A.M.P.E.R was based. Finally, the "reverse" approach is disregarded since no known products can be reverse engineered to find useful applications for the Pac-Man device. The following sections explain how the S.C.A.M.P.E.R. session was performed for each approach.

### *Substitute -*

Due to the limited options for paint applicators used in industry, none of them matched the functions of the Pac-Man device. Because of this, no existing devices were taken to make substitutions for the design basis. Instead, the team took the current Pac-Man device and motor and made a couple of changes. The first change is possibly modifying the horizontally adjusting mill table located below the main platform of the Pac-Man device. With the way it is designed now, it is positioned so that it can move the platform and the device in their current configuration. This may cause the assembly to pivot about the horizontal adjuster which warrants for the possibility of incorporating a new, wider horizontal adjuster. A replacement for this under current consideration could be to incorporate a mill table with a platform area close to or at the same area of the platform below which it will be mounted.

### *Combine -*

In deciding how the components would be coupled, the two focuses were the shaft from the motor to the Pac-Man device and the method of mounting the components to the platform on which they sit. For the shafts as they stand now, the shaft of the Pac-Man device is much larger in diameter than the shaft of the motor and so the couplings would be used to connect the shafts where they differ in diameter. The next focus was how each of the components would be secured onto the platform, and some ideas presented by the team included using fasteners and 90-degree brackets to link them together or welding the components onto the platform upon completion of their design and assembly with the rest of the components.

*Adapt -*

When considering adaptation, the focus was put on the component that acts as a drivetrain to meet the disk speed requirement of 800 fpm. The current design of the Pac-Man device is set up to where that the shaft that rotates the disc is coupled to the motor which controls the speed. The change to be made could be adding a reducer which would be used to take the rotational speed of the motor and to convert it into the linear speed at the outer edge of the disk. However, there are different methods for creating a system that can act as a speed reducer. Currently, the options under consideration are gears, belts with pulleys, and chains with sprockets. The next adaptation the team considered involves taking the vertically adjustable table below the base of the assembly and modifying it to be able to fix itself to the ground where it is stationed. The mobile table could be modified to have fasteners in them where they could be used to secure the table into the ground and place the assembly by the roofing shingles.

### Morphological Analysis:

After S.C.A.M.P.E.R was used to brainstorm over the main functions of the design project, the team then proceeded to morphological analysis with the goal of producing a variety of ideas for the individual components of the design concept. The steps taken in this involved identifying the design features of the assembly that have an influence on the primary function of the Pac-Man device and then accounting for the secondary components. The primary design features were identified as the configuration, type of drivetrain, the type of bearings that would be used to retain the shafts. Then the secondary design feature was identified as the method of vertical adjustability. Table 4.1 shown below shows how many ideas were generated for each of the mentioned design features that could be used in the final design concept. None of these ideas were subjected to criticism or evaluation until after they were presented. The purpose of a morphological table is to accumulate as many ideas as possible so that when all potential approaches are identified, the list of options can be narrowed down to the ideas that are more feasible.

Table 4.1. Morphological table with ideas presented by the team.

<b>Configuration</b>	<b>Drivetrain</b>	<b>Vertical Adjustor</b>
Parallel	Gears	Scissor Link Table
Perpendicular	Belt & Pulley	Hydraulic Column Table
Underlapping	Chain & Sprocket	Attach 4 Adjustable Legs
-	-	Car Jack
-	-	Pulley/Lift

After completion of the morphological table, the team then proceeded to each draw their own design concept by choosing from the table. It should be noted that the following concepts do not show the horizontal adjustor that would sit between the base of the Pac-Man Device and the top of the vertical adjustor table.

The first design concept shown below in Figure 4.9 was sketched by Aaron and the items used from the table were a perpendicular configuration, a worm gear to act as the drivetrain in the reducer, and a hydraulic column table for vertical adjustability. The table on which the assembly rests is capable of being fixed to the ground. Since it uses hydraulic columns, it is able to be vertically adjusted with a high degree of accuracy, as hydraulic columns are meant to carry large loads. The shaft of the motor is perpendicular to the shaft of the Pac-Man device and the worm gear in the reducer is used to transmit the rotational movement from the motor and through the shaft of the Pac-Man device.

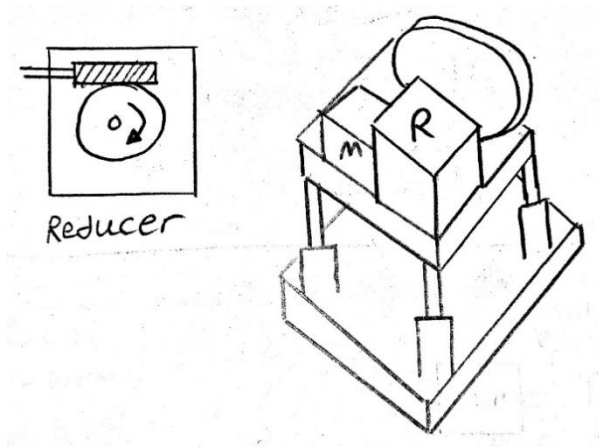

Figure 4.9. Pac-Man device is driven by a worm gear drivetrain speed reducer in a perpendicular configuration and uses a telescoping height adjustment table.

In this second design that was sketched by Sidney, shown in Figure 4.10, the motor was placed underneath the table to minimize the area needed along with the amount of paint being splashed on the motor. A belt drive system was incorporated for simplicity and to lower the cost of maintenance. For clarity, the lifting table was not sketched.

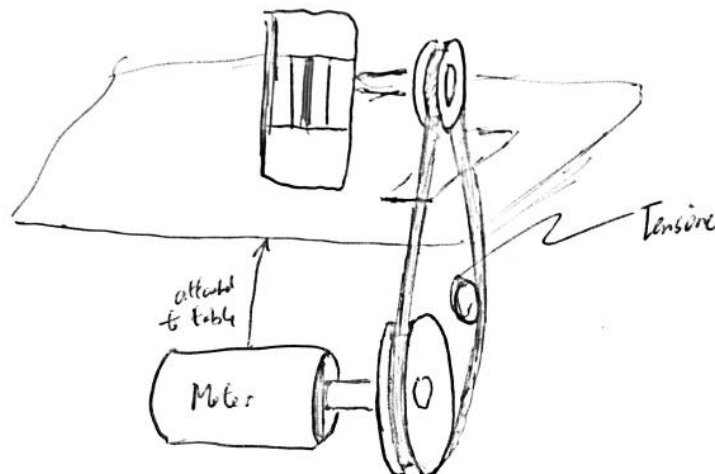

Figure 4.10. Pac-Man device is driven by a belt and pulley drivetrain with the motor placed underneath the platform to reduce space occupied on top.

The final drawing shown in Figure 4.11 was sketched by Taylor. It places the motor behind the Pac-Man device to minimize the width of the overall design. Due to the large distance between the two parallel shafts, a chain and sprocket system was employed in this instance. The required vertical adjustability was obtained by using a hydraulic scissor link table.

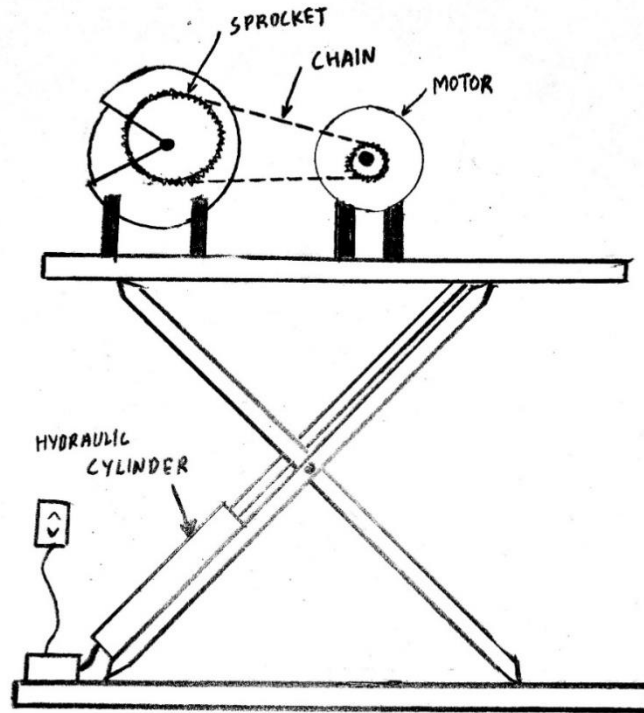

Figure 4.11. Pac-Man device is driven by a chain and sprocket system and height is adjusted with a scissor link table driven by a hydraulic cylinder.

## 4.2 Concept Selection Process and Results

After populating a morphological table with various design ideas, the team then proceeded to deciding which ideas in the table would be kept or eliminated. The basis under which this was conducted was feasibility since some of the ideas could carry out the intended function but would also violate some of the established constraints. Table 4.2 shown below is a Reduced Morphological table that shows the remaining design ideas agreed upon by the team. These ideas are subject to further evaluation while finalizing the design concept. With the feasible options known, the development of Pugh matrices came next to assist the team in deciding the best idea that would satisfy the design's primary functions. Since the drivetrain in the assembly is the core component in the primary function, two Pugh matrices were developed to evaluate the assembly's shaft configuration and the drivetrain design. These Pugh matrices can be found in Appendix B with a legend that shows how each idea was ranked, leading to the final determination.



Table 4.2. Reduced Morphological table that shows ideas that were deemed the most feasibly as agreed by the team.

<b>Configuration</b>	<b>Drivetrain</b>	<b>Vertical Adjustor</b>
Parallel	Gears	Scissor Link Table
Perpendicular	Belt & Pulley	Hydraulic Column Table
-	Chain & Sprocket	-

### Shaft Configuration:

When considering the main function of the design the team had to first decide which possible shaft configuration would be the best choice. As previously mentioned it was found that the only possible configurations are where the shafts are aligned in parallel to one another or perpendicular. After spending time brainstorming objectives that should be met by the configuration and sketching different ideas as shown in previous sections, a Pugh matrix for the shaft configuration was finalized. Through the brainstorming sessions, the design requirements and other factors necessary for functionality were reviewed to establish design objectives which were:

- How well each configuration meets the spatial requirements.
- How simple one is compared to the other.
- The ease of maintenance for each.

### *Spatial Requirements -*

When the team filled in the first Pugh matrix, both configurations were ranked as variable. This was decided because each choice of the drivetrain component that will be tied into the configuration will result in variation with the amount of space that gets taken. Multiple iterations were required to narrow down the choices in order to select a configuration for this objective.

### *Simplicity -*

Next, simplicity was evaluated to see which configuration would be the simplest to design. The team agreed that having a parallel shaft configuration would be the simplest between the two choices. It was discussed that aligning the axis of rotation for the shafts would be easily accomplished compared to perpendicular alignment which was found to have more room for error. Also having a parallel shaft would be allow for more options to choose for a drivetrain than with a perpendicular configuration. For example, a chain and sprocket drivetrain would only be able to accommodate a parallel configuration as no design exists for a perpendicular configuration.

### *Ease of Maintenance -*

Finally, when considering the ease of maintenance, each shaft orientation yielded different results based on the drivetrain mechanisms used. However, regardless of which mechanism is examined, the maintenance required for a parallel drivetrain system was determined to be less than that for a perpendicular system.

### Drivetrain:

Upon completion of evaluating shaft configuration, the team proceeded to determining the best choice of a drivetrain to use the motor speed to get the disk speed specified by the user. When choosing between using gears, a belt & pulley, or a chain & sprocket, the team once again reviewed the main design requirements to fully understand what needed to be accomplished by the choice of the drivetrain. The team found the required design objectives of the drivetrain to be:

- Initial Cost
- Maintenance Cost
- Reliability
- Efficiency
- Spatial Requirements

### *Initial Cost-*

The various drivetrain mechanisms also vary vastly by the initial costs required to build them. Belt and chain driven systems are relatively low cost when compared to gear driven systems. This is because any gears used would require a moderate degree of machining to make them. This machining, based on the particular speed reduction ratio required, would raise the cost of the assembly.

### *Maintenance Cost-*

The cost of maintaining a gear or chain driven system is more than that for a belt driven system because periodic lubrication is required. For belt and chain driven systems, additional tensioning is also needed over time.

### *Reliability -*

From the research conducted, it was concluded that gears are the most reliable mechanisms out of the three as well. Belts tend to slip and stretch over time which can lead to failure. Chain and sprocket systems can experience stress damage that also leads to failure if it is not properly lubricated or if there is any misalignment. Conversely, gear driven systems tend to last much longer than both of its counterparts.

### *Efficiency -*

Given that all three of the mechanisms considered have efficiencies ranging from 97-99%, each of these options were given the highest consideration in this category.

### *Spatial Requirements-*

Given the orientation of the motor and Pac-Man that would minimize the width of the entire assembly, the drivetrain must be capable of spanning the distance between the two shafts. Considering how large the Pac Man device is, belts and chains appear to be the more logical choice. If a gear driven system was to be used, the gears would either have to be fairly large or an idler gear would have to be added.

### **4.3 Concept Designs**

At the end of the Pugh matrix process, the team further narrowed the options presented in the reduced morphological matrix and then proceeded towards concluding the final concept selection. In this process, each team member sketched their own final concept to propose to the team. Upon presentation, all propositions were evaluated by each team member. Each concept sketched covers all components that will be used. This includes the configuration, the drivetrain, and the choice of a vertically adjustable table. The evaluations were conducted with the use of a weighted decision matrix also shown in Appendix B. The following figures are the proposed concept design sketches drawn by the team members. It should be noted that the horizontal adjusting mechanism is not shown since the sketches only elaborate on the drivetrain and vertical adjustability. Due to the similarity between two members' proposed concepts, only two are represented below.

#### *Concept 1 -*

Figure 4.12 is Concept 1 drawn by Aaron Fisher. It utilizes a vertically adjustable table with hydraulic columns that are controlled by a mechanical spring-loaded foot pump. The motor is oriented behind the Pac-Man device mounted on an elevated stand and connected by a belt and pulley system between the two parallel shafts. The table also can be lifted by a forklift with the inserts at the base of the table allowing it to be transported from one location to another.

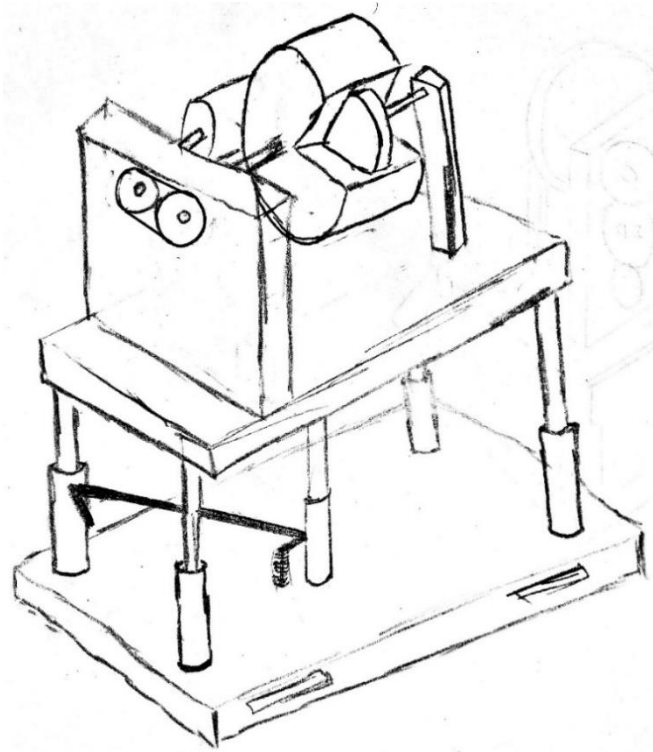

Figure 4.12. Concept 1 utilizes a belt and pulley system as the drivetrain with a parallel shaft configuration and a telescopic column table for vertical adjustment.

*Concept 2 -*

Figure 4.13 is Concept 2 sketched by Sidney Wong. The motor was also placed directly behind the Pacman device to prevent collision with the x-y adjusting mechanism underneath the table, as observed from an earlier design. By placing the motor behind the applicator, spatial consumption was minimized, allowing for easy access to the motor and multiple units to be placed side by side. A housing shall enclose the belt and toothed pulley but was omitted in the sketch to provide details of the belt drive. Like the previous figure, the horizontal adjustor would be fitted between the top of the table platform and the bottom of the base of the Pac-Man device.

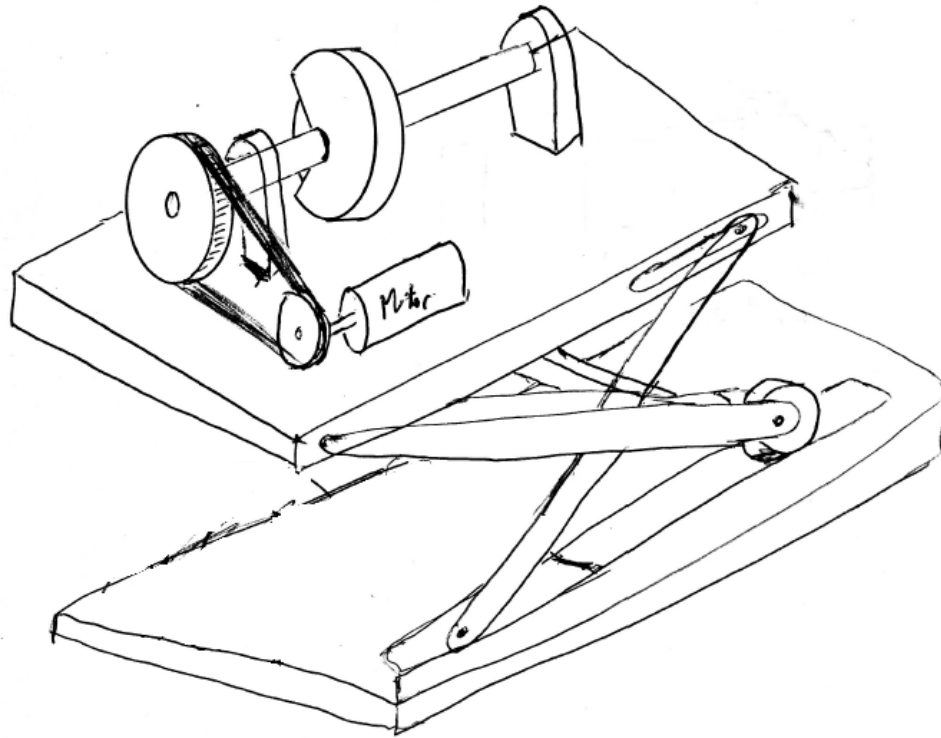

Figure 4.13. Concept 2 utilizes a belt and pulley system as the drivetrain with a parallel shaft configuration and a scissor link table for vertical adjustment.

After considering the possible concepts, the weighted decision matrix was used to find out that Concept 2 would be the best choice of a design to name the official concept. Besides the choice of a vertically adjustable table, the only real difference between the two is that Concept 1 has the motor resting on an elevated stand whereas Concept 2 has the motor resting on the platform behind the Pac-Man device. Although it is believed that a scissor link table will be most likely incorporated into the final design, the team will be putting its focus on the assembly that rests on the table first. The team will wait to assess the outcome of the assembly weight and configuration so that better judgement can be used in selecting a table for optimum cost effectiveness and performance. Figure 4.14 shows the final prototype that represents the concept design direction the team is headed.

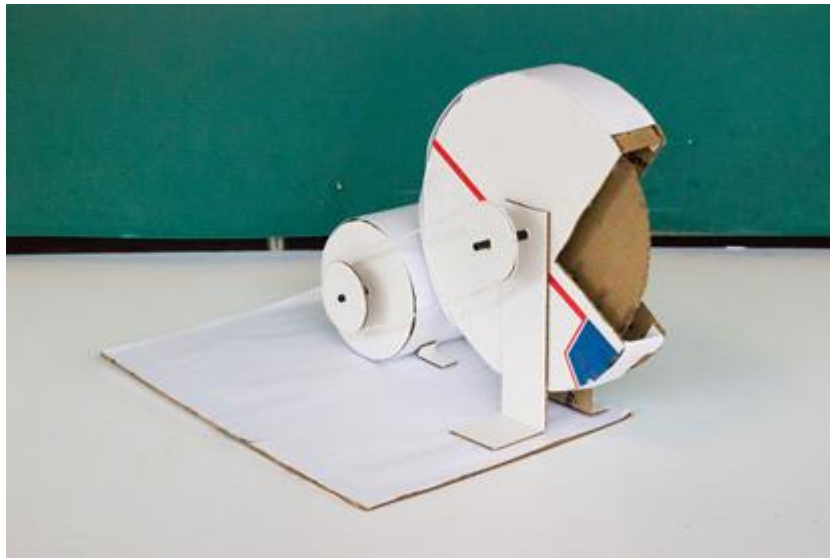

Figure 4.14. Cardboard prototype representing a physical concept model of Concept 2 which uses a belt and pulley with the motor mounted to the platform.

#### 4.4 Selected Design Concept

The design concept model, in Figure 4.15, shows a SolidWorks assembly of the existing Pac-Man device with motor drive system to verify the placement of the components. In this model, the assembly has been rearranged and coupled with a belt and toothed pulley system that transfers torque to the disk. Since the height adjustment table depends on the total weight and balance of the device, it was agreed upon by the team that the adjustment table will be purchased once the components above the mounting plate have been finalized. Therefore, the table has been omitted from the prototype models until further progress has been made. Although this is not the official design, it represents the direction in which the team will go with finalizing the design.

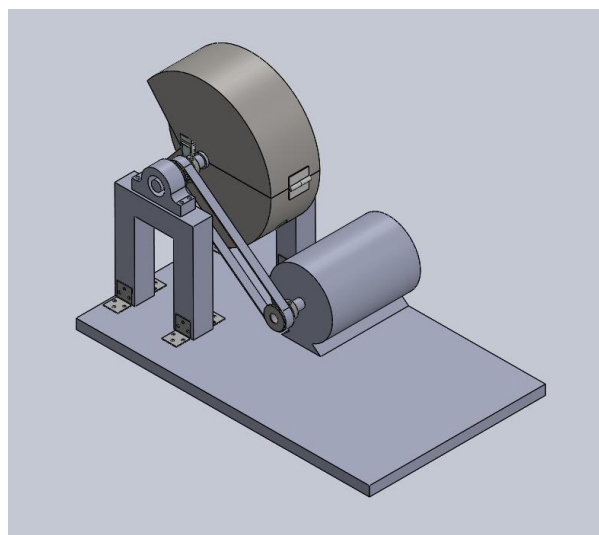

Figure 4.15. SolidWorks model representing Concept 2 without the vertically adjustable table shown.

## 4.5 Concept Functionality

The primary function of this device is to apply a visible, correctly placed paint line to a moving sheet of roofing shingles. To accomplish this, several smaller functionalities will be achieved. To promote a vibrant paint line, the paint application wheel must be accelerated to and sustained at the correct speed. The motor and the belt and pulley system by which it is attached will control this speed. By using a variable speed motor, the overall angular speed of the system will also be able to be controlled by the user. The belt and pulley system will be capable of transferring torque from the motor to the rest of the assembly. To ensure that the line is placed in the proper horizontal location along the sheet, the mill table underneath the Pac-Man device and motor will act as a horizontal translator. This adjustability will allow the paint line to be located correctly to within the required tolerance. The vertical adjustability will be achieved through the height adjustable table that the group intends to purchase as a completed product. This table will use an electrically or mechanically controlled hydraulic system to be able to raise and lower as needed. The base of the table will be secured to the ground upon completion and installation of the product. This will prevent the risk of possible tipping and misalignment.

## 4.6 Risks and Unknowns

### *Speed Control -*

In this model, the belt and toothed pulley system may act as a speed reduction system as well. The motor selected by the previous senior project team was determined to be able to accelerate the disk to the required speed range with the proper controller. For this reason, it is expected, though not confirmed, that the speed reduction ratio between the motor and the disk will be near 1:1. Additional research and calculations will be done to verify the required ratio.

### *Structure -*

Given the belt and toothed pulley system are the choice for the speed reducer, there are some structural factors that will be considered later in the project. One notable factor is that the way the motor and speed reducer are coupled to the Pac-Man device may cause torsion on the Pac-Man devices legs due to the driving force taking place in the motor and speed reducer. At this point it is not clear if the current mounting for the Pac-Man device is susceptible to failure due to the torsional stresses that will vary with motor speed. Further testing will be needed in order to determine if some mounting reinforcement will be necessary or not.

### *Mill Table -*

The Pac-Man device and motor also weigh a considerable amount and lifting this assembly off the ground may promote tipping. Special concern will be awarded to avoid this possibility. Since the overall weight of the assembly will be relatively centered and the mill table contributes a significant amount of weight to the same area, this concern will likely be resolved in the chosen design. This will also be combated by securing the device to the ground.

## Chapter 5: Final Design

### 5.1 Design Updated

The design was then updated from the previous quarter and several more details were finalized.

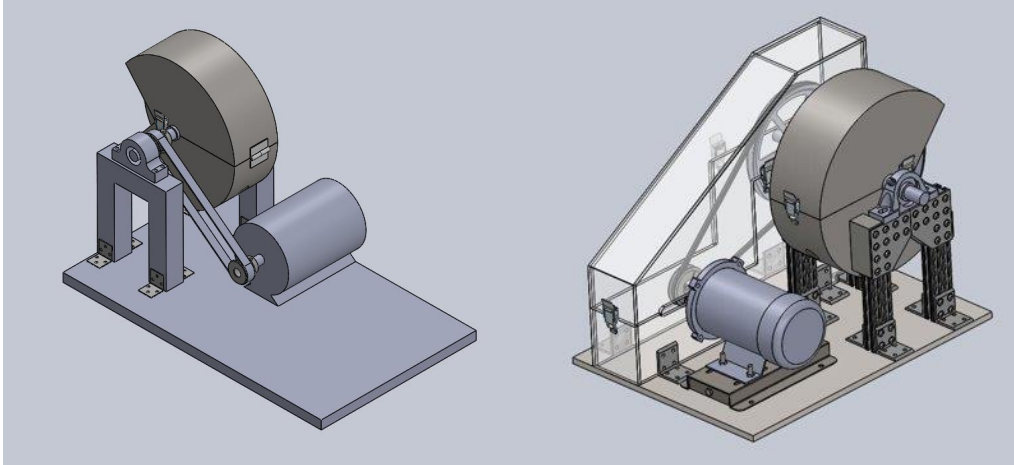

Figure 5.1. The left image represents the concept model and the right image represents the improved design after further analysis.

Since the chosen design opted to use a belt and pulley drivetrain, the shaft which the previous team intended to support the disk had to be redesigned. New shaft diameters, lengths, and notch sizes were calculated based off of the appropriate force and stress analysis conducted.

The input and output pulleys sizes were also finalized. The resulting sizes will yield a speed reduction ratio of approximately 1:3. To keep the belt and pulley system properly tensioned, a sliding base was selected to support the motor. This will allow for periodic tensioning in the system.

To eliminate safety concerns, a housing to enclose the belt and pulleys was incorporated into the assembly as well. This design features two separate halves where the top can be unlatched and removed from the bottom.

The stands which support the Pac-Man device were chosen to be made from aluminum extrusion bars. The bars will be assembled using brackets, braces, and fasteners which come standardized with aluminum extrusions.

Lastly, the Pac-Man shaped housing was also altered. Flaps were added to either side of the housing which will be capable of being fastened to the aluminum extrusion support stands. This was done to make the housing easier to work with and assemble. Originally, the housing was only supported from the bottom by being placed on top of two wooden blocks.



## 5.2 Overall Description and Layout

The entire finalized design can be seen below. This assembly mainly has four different subassemblies.

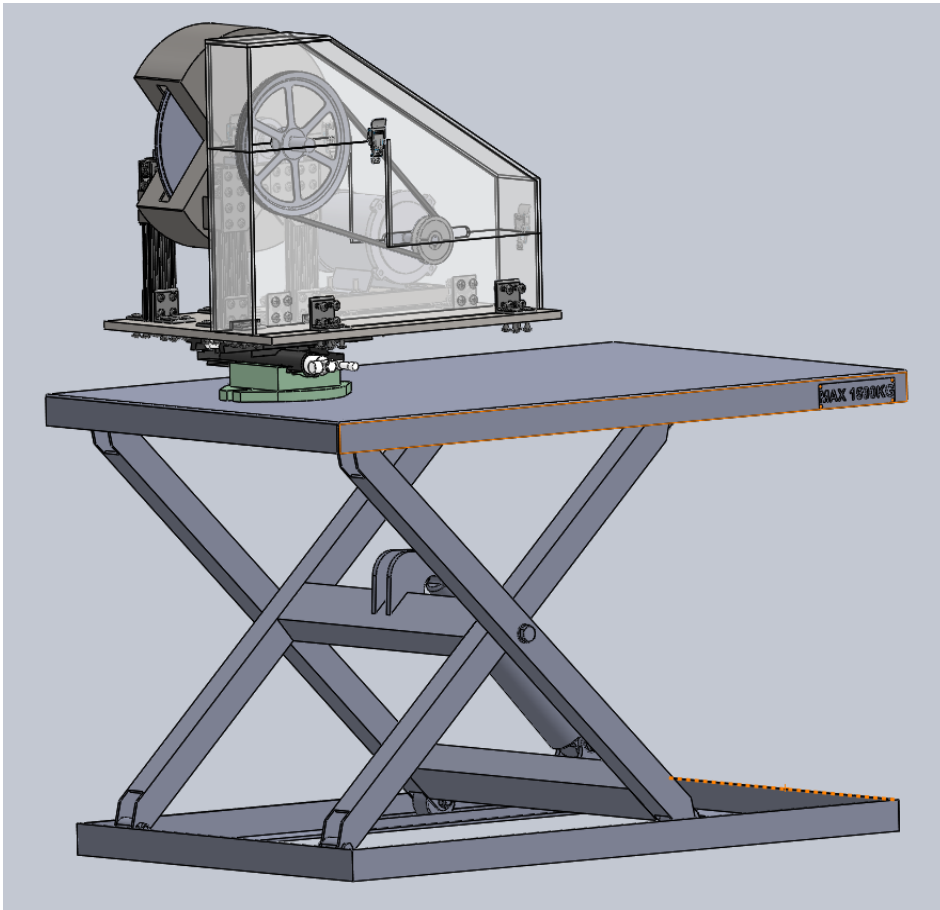

Figure 5.2. A view of the entire finalized assembly with all components included.

First, the scissor lift table and the mill table make up the base of the entire structure. The powertrain then includes both pulleys, the belt, VFD, and motor. The stands which support the output shaft and Pac-Man housing are also their own subassembly. Lastly, the shaft, disk, bearings, and retaining rings make up the final subassembly. Since each of the components in the subassemblies shared the same concerns, the following section will be broken into these four parts.

## 5.3 Final Design

After completion of part orders, manufacturing and successful assembly, the design shown below in figure 5.3 shows what it looks like. The only difference between this one, and the last updated design is the choice of a lift table used. The previous update had no wheels on it and was thus immobile, and so to meet the portability requirements, a wheeled lift table was used in place of the one without wheels.

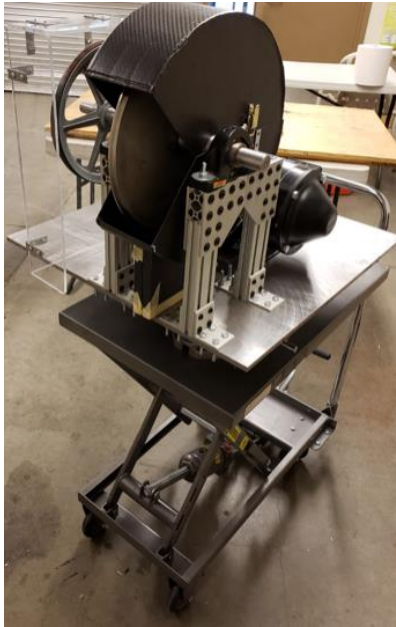

Figure 5.3. A view of the entire finalized assembly.

## 5.4 Detailed Design Description

### Base

The purpose of the base subsystem is to provide the device with the ability to move in the x, y, and z directions. The scissor lift table will be able to lift the entire assembly up and down. Even though the entire Pac-Man assembly is of considerable weight, these types of tables come with rated load capacities up to 2000 lbs and will be more than capable of supporting the desired loads. This will be controlled by a remote which comes included with the scissor lift table. The mill table which rests on top of the scissor lift table will allow the device to be position forward to back and side to side.

### Powertrain

The powertrain subsystem will consist of the input and output pulleys, motor, VFD, and belt. By examining the speed torque curves which apply to the chosen motor, it was found that a speed reduction would be necessary to get the edge of the paint application disk to run at the desired line speed.

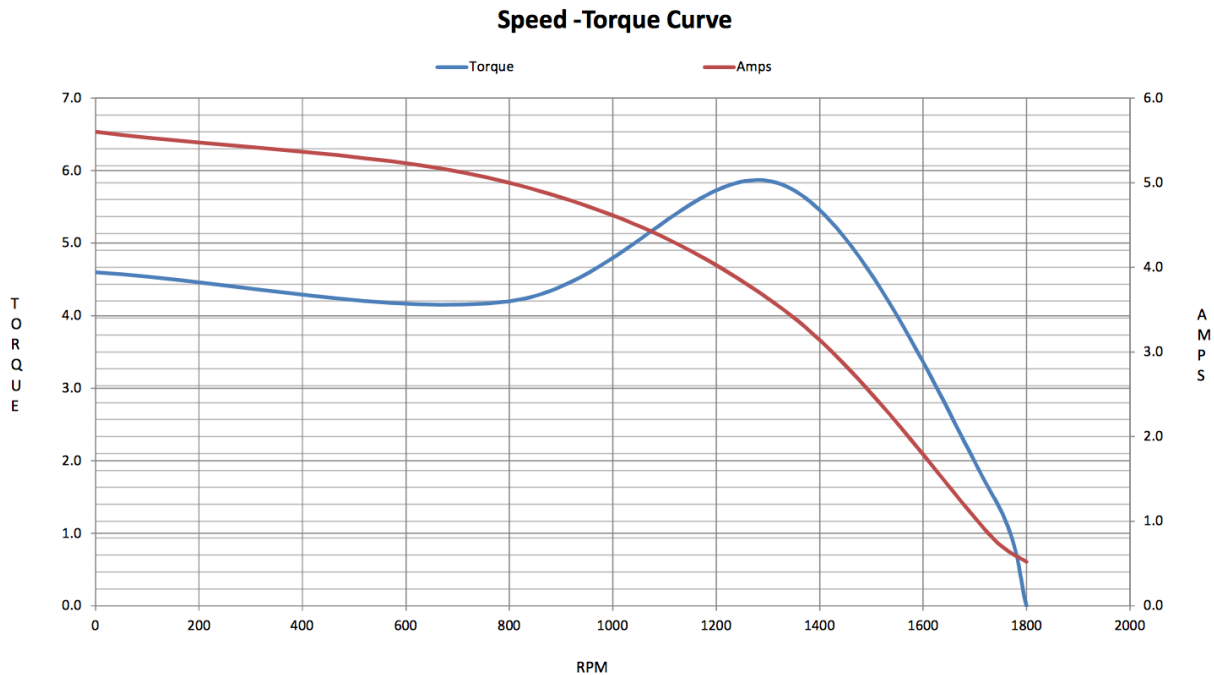

Figure 5.4. Speed – Torque data of the motor used for determining the input torque and it's corresponding angular velocity.

Since the torque greatly reduces at speeds greater than 1300 rpm, it would be preferable for the motor to not operate near that point. To get the edge of the disk to operate at the desired speed, about 800 fpm, it would have to be rotating around 260 rpm. A speed reduction ratio of 3:1 was chosen to meet these two requirements. The output pulley will be 9 inches in diameter and the input pulley will be approximately 3 times smaller.

### Power Control

The motor that drives the belt and pulley drivetrain is powered with a 120 V source and has a speed controller as shown below in figure xx. Given the simplicity of this control box compared to the other options the team sorted through, this one is able to run the motor close enough to the desired speed and is compatible with our 3-phase induction motor. The only downside of this choice is that it cannot be initiated at a starting speed lower than the 40 mark on the speed settings.



Figure 5.5. KBMA-24D Black (9533) AC Drives, Nema-1 speed controller

### Output Shaft Support

The stands which support the output shaft have been chosen to be redesigned from the previous year's senior project. Aluminum extrusion bars were chosen over the square steel bars currently in use so that the alignment and manufacturability of the stands would be improved. Since the redesigned shaft has the same dimensions at the bearings as the previous one, the same bearings can be used for the new stands as well.

### Output Shaft

Since a belt and pulley drivetrain have been chosen, the shaft from last year's senior project had to be redesigned. All forces acting on the output shaft were found and taken into consideration when deciding on new diameters. A MATLAB program was written to allow the user to input any diameter and receive the factor of safety for the point of highest stress along the shaft. The hand calculations and code for this process can be found in Appendix H.

### Shaft/Disk Fitting

In the assembly process of fitting the disk to the shaft one complication was encountered but was resolved with the use of a taper lock bushing as shown below in figure 5.6. The problem we had was that the shaft and disk were machined and sent to our work station, had too much clearance between them. This caused the disk to wobble a lot when in free rotation and given the amount of clearance, the key kept falling out. The reason the taper lock bushing was used is because the small extruded diameter has a slight angle to it that allows for it to be inserted into the disk to a certain point while simultaneously tightening its grip on the shaft to ensure zero clearance and the best grip. The fasteners are then inserted to secure the bushing to the disk once the fitting is satisfied.



Figure 5.6 Qd Bushing, Qt, 1-3/16" B Dia., 1.250" L used to fit the disk to the shaft.

## 5.5 Analysis Description and Results

To ensure that our selected dimensions for some of the components allow for the satisfaction of the design requirements, calculations were conducted with the use of knowledge obtained in previously taken courses at Cal Poly State University. Additionally, MATLAB was used to assist in changing dimensions with iterations until satisfactory results were obtained. The calculations can be found in Appendix H and focus was mostly on the shaft and the drivetrain when:

- Calculating the critical speed of the paint applicator shaft
- Shaft notch radius analysis
- Shaft sizing

### *Shaft Critical Speed -*

Since the shaft that rotates the disk has loads on it, there are small but considerable amounts of deflection that need to be accounted for when the shaft is in rotational motion. As the shaft rotates it further deflects more than in its static state as a result of the centripetal force that is exerted on it, which varies depending on the shaft's rotational speed. This combined amount of deflection is a concern because there is a point to where the shaft will deflect too much and begin to destabilize if the speed exceeds what is known as the critical speed. The critical speed is the rotational speed limit to which the shaft can be run before instability occurs. Calculations were done to seek out our shaft's critical speed to determine if the dimensions selected will allow for it to operate at the required angular velocity without causing problems to the system. Based off the dimensions chosen for the shaft and with the use of methods used in the Shigleys Mechanical Design textbook [7], a critical angular velocity of approximately 507 RPM was calculated, which is twice the amount at which the disk needs to be rotated.

### *Notch Radius Analysis -*

When considering the types of loads that would be imposed on the shaft from the drivetrain, the team discovered that the shaft would have stress concentrations located at each diameter change point along the shaft. These stress concentrations would result in quick failure at the diameter change points with even a small load imposed on the shaft for a prolonged period of time. In order to mitigate this problem, the Shigleys textbook was used to calculate the

dimensions of the notch radius values that would be needed to deal with certain loads imposed on the shaft. Based on how the powertrain transmits energy from the motor, it was found that the shaft would be subjected to torsion from the twist of the large pulley and bending from the forces in the belt. Using relationships between large diameters, their neighboring small diameters, and chosen  $K_t/K_{ts}$  values, the team calculated the notch radii that would be needed for each diameter change points. At each respective change point, the radius that had the higher value from one load type compared to the other load type would be used since the larger radius is the limiting factor. Figure 5.7 and figure 5.8 shown below were used in determining the radius values for each load type

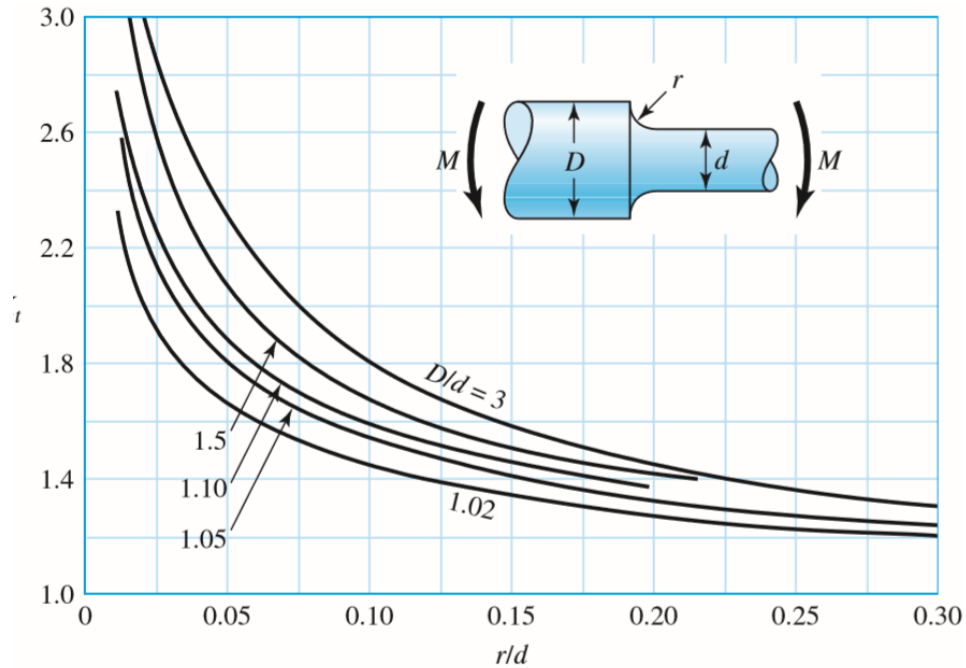

Figure 5.7. Graph used for determining  $r$  when shaft is subjected to bending stresses with  $K_t = 1.6$

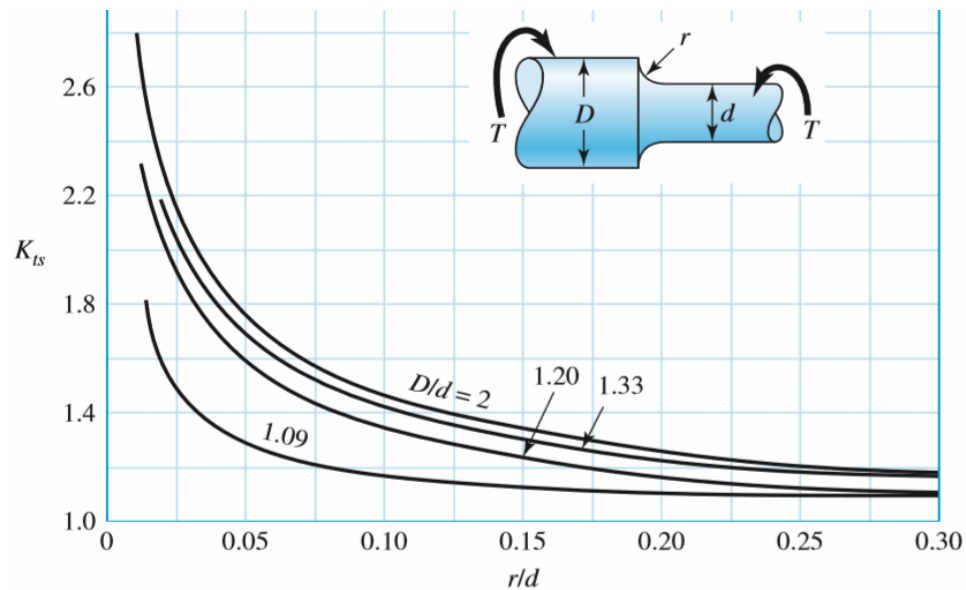

Figure 5.8. Graph used to  $r$  when shaft is subjected to bending stresses with  $K_{ts} = 1.4$

## Shaft Sizing –

The approach to shaft sizing was done with different iterations of shaft lengths and diameters that would be used in stress analysis with the known loads that would be applied at their locations. In the analysis shear moment diagrams were used to identify the greatest normal and shear stresses that would be imposed on the shaft, and the calculations done found them to be applied in the XZ and YZ directions as seen in the calculations found in Appendix H. The maximum stresses calculated would verify that our chosen shaft diameters would allow for the loads to not exceed the ultimate strength of the shaft material. In the analysis, the same  $K_t$  and  $K_{ts}$  values were used as in the notch radius calculations.

## 5.6 Cost Analysis

Table 5.1. Bill of materials and procurements list

Bill of Materials						
Items	Source	Item Number	In Hand?	QT Y	COST/ UNIT	TOTAL COST
Double Standard Rails—T-Slotted Aluminum, 2"x1", 6ft	McMaster Carr	47065T107	Yes	1	\$30.39	\$30.39
Extended Corner L Brackets	McMaster Carr	47065T253	Yes	8	\$7.91	\$63.28
Corner Surface Brackets	McMaster Carr	47065T274	Yes	8	\$14.77	\$118.16
Inner Corner Braces for Single Rails	McMaster Carr	47065T216	Yes	4	\$4.96	\$19.84
Standard End-Feed Fasteners, Pack of 4	McMaster Carr	47065T142	Yes	40	\$2.30	\$92.00
Low Carbon Steel Sheet, 1/2" Thick, 24"x24"	McMaster Carr	1388K281	Yes	1	\$253.08	\$253.08
1/2 HP Induction Motor	Marathon Motors	Y280	Yes	1	\$649.49	\$649.49
3" V-belt Pulley	McMaster Carr	6245K33	Yes	1	\$11.16	\$11.16
9" V-belt Pulley	Grainger	3LC23	Yes	1	\$31.73	\$31.73
V-belt	McMaster Carr	6186K142	Yes	1	\$32.60	\$32.60
Motor Tensioner Mounting Base	Global Industrial	WGB381983	Yes	1	\$15.25	\$15.25
KBMA-24D Black (9533) AC Drives, Nema-1	KB-Controls	9533	Yes	1	\$168.00	\$168.00
Qd Bushing, Qt, 1-3/16" B Dia., 1.250" L	Grainger	5UHZ7	Yes	1	\$10.55	\$10.55
Drop in Fastener With Stud 1/4"-20 Thread	McMaster Carr	47065T233	Yes	4	\$1.52	\$2.31
Silver Straight Surface Bracket, 2" Long for 1" High Rail	McMaster Carr	47065T255	Yes	2	\$6.07	\$12.14

Key Stock for Pulley	McMaster Carr	98491A117	Yes	1	\$1.19	\$1.19
Latches	McMaster Carr	1794A55	Yes	2	\$11.18	\$22.36
16/3 8' Black Power Tool Cord	Home Depot	N/A	Yes	1	\$9.98	\$9.98
3 in Zinc Butt Hinge	Harbor Freight Tools	N/A	Yes	1	\$1.89	\$1.89
Shaft/Disk Labor & Materials	B&G Machine & Welding	N/A	Yes	1	\$1,625.00	\$1,625.00
Bearings	McMaster Carr	557099	Yes	2	\$74.54	\$149.08
Key Stock for Disk	McMaster Carr	98491A136	Yes	1	\$1.48	\$1.48
Lift Table	Pittsburgh Automotive	61405	Yes	1	\$169.99	\$169.99
Mill Table	McMaster Carr	5234A1	Yes	1	\$563.97	\$563.97
2 Oz. Epoxy J-B Welds	Home Depot	N/A	Yes	1	\$5.67	\$5.67
5/8" Galvanized Cut Washers	Home Depot	N/A	Yes	2	\$0.46	\$0.92
1/2"D - 13"X2" Carriage Bolt	Home Depot	N/A	Yes	2	\$0.46	\$0.92
1/2"D Galvanized Hex Nut	Home Depot	N/A	Yes	2	\$0.38	\$0.76
1/4"D - 3"X1/2" Hex Bolt	Home Depot	N/A	Yes	4	\$0.46	\$1.84
1/4 x 1/2 Hex Bolt	Home Depot	N/A	Yes	32	\$0.17	\$5.44
Hex Nuts-USS 1/4	Home Depot	N/A	Yes	29	\$0.06	\$1.74
5/16 x 1 Hex Bolt	Home Depot	N/A	Yes	4	\$0.17	\$0.68
5/16" Cut Washers	Home Depot	N/A	Yes	4	\$0.12	\$0.48
3/4" Cut Washers	Home Depot	N/A	Yes	20	\$0.40	\$8.00
<b>Estimated Project Spending:</b>						<b>\$4,072.21</b>
<b>Allowed Sponsor Budget</b>	<b>\$15,000</b>					
<b>Remaining Sponsor Budget</b>	<b>\$10,928</b>					



## **5.7 Choices of material, geometry, and components**

Since the previous design was too heavy, various parts have been redesigned to be lighter weight. Therefore, the decision to replace the steel Pacman support legs with T-slotted aluminum extrusions. In addition, the Pacman disk has been made thinner along with the Pacman housing, which will be constructed with carbon fiber composites. The low carbon steel base plate will also be replaced with a sheet of aluminum. All the components replaced will have the same general geometry they were originally designed with minor adjustments.

## **5.8 Safety and Maintenance/Replacement**

From the final design there are some safety precautions that need to be taken into consideration when approaching the device while it is in operation. Some of the moving parts may cause loose material on clothes or other items to get caught in them which may result in bodily harm and damage to the device. Some components on the design also require maintenance which mostly involves nothing more than changing fluid and occasional replacement of worn down parts. This is a factor that cannot be put off since all moving components are inner-connected and failure of one may result in failure in other components.

### *Safety -*

Based on what is viewed from the CAD model some notable hazards include the moving disk, the lift table's scissor links, and the mill table. The following three paragraphs will elaborate further on these hazards and provide some recommendations to mitigate the dangers that they pose.

The hazards posed by the rotating disk are of the most concern because there is a danger where if something were to get snagged into the disk, it will likely get tangled and may cause the rotating disk to jam. This would also be a dangerous scenario because if the motor is still running when this occurs it may overstrain the motor and cause too much stress on the output shaft or inner motor components. Additionally, bodily harm is a potential hazard because there is the risk that items on the user's clothes will get caught and it may pull them closer to the hazard. Since the design lacks an emergency stop mechanism, it is highly recommended that gloves are worn at all times to protect the user's fingers, and no loose items such as jewelry or very loose clothing be worn when in operation.

The hazards posed by the table scissor links mostly include pinch points that could cause bodily harm no greater than minor injuries; there are pinching points for both cases where the table height is raised and lowered. As the table is lowered, it causes the scissor link corners on the left and right side of the intersecting points to close together which is where the pinching will occur. As the table is raised, the scissor link corners above and below the intersecting points are closed together and this is where the pinching points will be found. In addition to the bodily harm that may come from this, it is also important that the user ensures that nothing else gets snagged between the pinch points so that there is no overstress on the scissor links. Failure to do so will cause the links to fail which in turn will most likely result in the entire unit falling off since these links bear the load of said unit. It is recommended that the user ensure that these corners are clear of any items that may get caught, and to keep hands away from that region of the table when height adjustment is underway.

The hazards posed by the mill table are minimal compared to the previously mentioned hazards. One notable hazard is that it shifts the bulk of the design's weight around which contributes to the change in the center of gravity of the paint application unit. This is relevant because there exists a tipping hazard that may occur if the bulk of the weight is shifted too far forward when not properly fixed into the ground. It is recommended that the mill table be adjusted to where the weight is near the center of the table but not to the point where it causes too much bending stress on the mill table as the weight goes further back.

#### *Maintenance -*

For this design, there are a number of components that will require maintenance and replacement after a certain time period has gone by from prolonged use. Among the most important components that need to be kept track of for maintenance are the bearings, the lift table's hydraulic column, and the drivetrain belt.

- The bearings are secured in a pillow block that contains them and they allow the shaft to rotate between the outer part of the bearing and the inner part of the pillow block casing. Lubricant is contained between the bearing and the casing to allow the shaft to rotate freely as it is being driven, however overtime the lubricant becomes dirty and its ability to overcome friction becomes less effective. In order to mitigate this problem, the user must check the bearings performance to see how much friction exists and replace the lubrication when necessary.
- The hydraulic column bears a significant amount of the load due to the paint applying unit when it is stationary and in motion, and as long as it has clean and proper hydraulic fluid, it won't have any issues with adjusting the height. Like the bearings, friction can be an issue if the fluid is not taken into consideration when maintenance is required and so it is important that the column stays properly lubricated to mitigate failure due to friction wear.
- The drivetrain belt must be properly tensioned at all times when in use in order to get the desired output pulley speed for the paint application process. To extend the life of the drivetrain belt, it is recommended that the belt be loosened when not in operation to minimize the amount of strain put on the belt so that it can be used longer. Replacement of the belt in the event of failure is feasible since the adjuster on which the motor sits allows for easy insertion of a new belt when needed.

## **Chapter 6: Manufacturing**

### **6.1 Procurement**

Majority of the components, such as stock material, brackets, and fasteners, will be sourced from McMaster-Carr or Home Depot. More specialized components, like the variable speed drive, were purchased from smaller distributors. Parts that were acquired from the previous senior project team included a ½ HP, 3-phase induction motor, pillow block bearings, and a mill table. The project began with a budget which was approximately \$15,000. Now that it is reaching completion, it is clear to see that the project is under budget while costing \$4,084.

### **6.2 Manufacturing Plan**

#### Manufactured Components:

##### *Shaft:*

The shaft was designed and then sent to GAF to be machined. The final product was received during the 3<sup>rd</sup> week of fall quarter.

##### *Disk:*

The disk was designed and then sent to GAF to be machined. The final product was received during the 3<sup>rd</sup> week of fall quarter. The disk received was not machined to the desired specifications. Instead, it was missing nearly 0.5” worth of extruded volume along the length of the shaft.

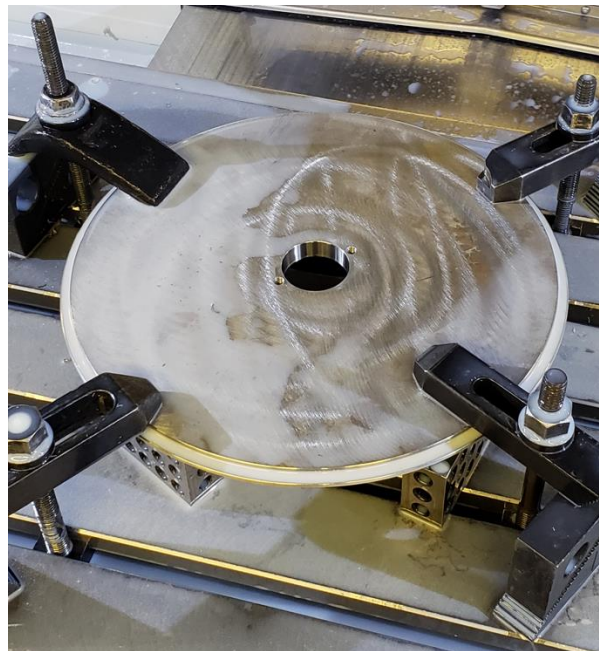

Figure 6.1. The disk bore being widened for the tapered bushing

A tapered bushing was used to ensure that the new shaft's dimensions would work with the shaft and rest of the design. The bore size had to be increased to fit this new bushing and cut at the same small angle that the taper lock bushing had to ensure proper fitting into the disk which in turn would guarantee grip on the shaft.

*Pac-Man Housing:*

The Pac Man housing was remade out of carbon fiber. With the help of Dr. Elghandour, the team managed to find enough scrap foam material to carve the mold's shape. A half circle was formed by cutting and filing the foam. Next, the material was covered with a layer of plastic and non-stick lubricant. These layers would layer help the carbon fiber detach easily from the foam.



Figure 6.2. The carbon fiber mold being prepared and the finished housing

The mold was then layered with multiple sheets of carbon fiber set in resin. Once these layers were attached and smoothed, the entire piece was placed in the furnace to cure. After the pieces were hardened, the two halves of the Pac-Man housing were secured together with latches and a hinge. These were attached using a hand drill and standard fasteners from Home Depot.

*110V/230V Black Box:*



Figure 6.3. The variable frequency speed drive used

This speed controller was wired to the required specifications by a Cal Poly Electrical Engineer. This VFD was chosen because it is capable of converting the standard 110V power source from any wall outlet to 230V to work with our motor.

### Assembled Components:

#### *Legs:*

The legs which support the shaft, bearings, and disk were rebuilt using T-slotted aluminum extrusion bars. The bars were cut close to the required lengths using a chop saw and then the remaining material was removed using a mill.

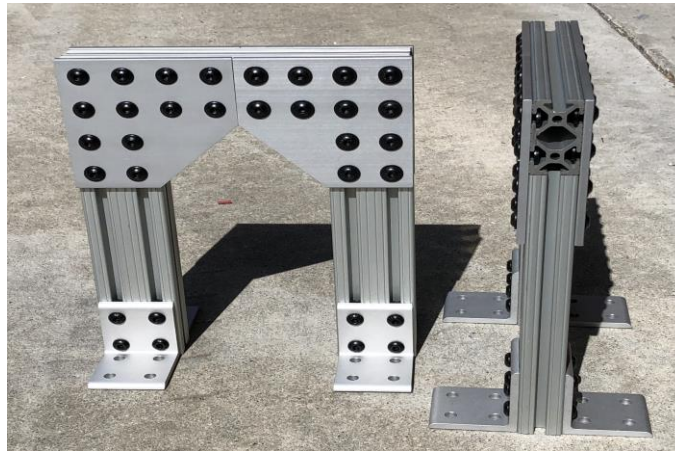

Figure 6.4. The shaft support legs without the bearings.

This was done to ensure a flat bottom which will have no problem sitting flush with the plate. By rebuilding these legs with more precise materials, the shaft will be better aligned. Once fully assembled, the bearings were attached to the top of the legs.

#### *Base Plate:*

Once all of the components were received, the team was able to locate where on the base plate everything needed to be secured.

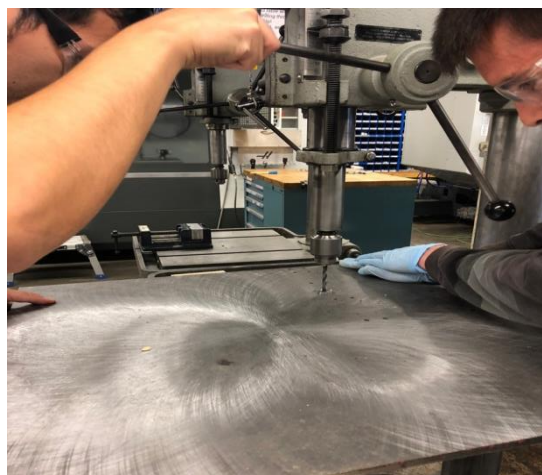

Figure 6.5. Drilling the holes into the base plate

After measuring the distances between the motor mount, shaft support legs, and mill table fasteners, the desired locations were marked and drilled using a drill press. The fasteners were then installed once all drilling was completed.

#### *V-belt Installation:*

After securing each of the components to the base plate, the V-belt was attached by adjusting the motor mount to lessen the distance between the two shafts. Once the belt was installed, the motor was moved away from the other shaft to tighten it.

#### *Belt Housing:*

The belt housing was made once all of the components were attached to the base plate and the distance between the two shafts could be measured. First, a sheet of acrylic was cut into rectangular and trapezoidal shapes using a band saw.



Figure 6.6. Cutting the panels for the belt housing.

The resulting pieces were then attached together using brackets, fasteners, and a hand drill. The brackets which support the housing were attached to the baseplate using JB weld.

### **6.3 Challenges**

A few unforeseen challenges were encountered during this project. First, the team was not prepared for the issues that it faced with the power supply. It should have been recognized that operating at a higher voltage would raise some additional problems. Also, the team was caught off guard when the disk was received machined incorrectly. Although the incorrect dimension was critical, with the help of on campus faculty, the team was able to bring a solution to fruition.

### **6.4 Future Recommendations**

Any design teams who might inherit this project should keep a few details in mind. The connection between the largest pulley and the shaft is not secure enough. It may be required to pursue a method of securing it axially along the shaft against the step. Additionally, for this prototype to be realistically successful, a pumping system must be designed and incorporated into the Pac-Man housing to replenish the paint

## **Chapter 7: Design Verification Plan**

Upon complete assembly of the design, the team will proceed to conducting a series of tests to verify that the design operates as intended and satisfies all specified design requirements. All of this must be accomplished while aiming to achieve the optimum quality of paint lining to be applied to the roofing shingles. It is anticipated that the likelihood of running into problems when testing the design will be due to the vibration of the operating motor and the change in weight distribution as the horizontal adjuster changes the location of most of the weight. Observations will be made to see if these anticipated problems occur through the planned tests. Once the structural integrity has been assured the team will move on to checking to see if the device has been designed properly to be feasibly transported to satisfy the portability requirement and if it can be feasibly fixed into the ground when ready to be used. Finally, the team concludes the testing series by using the same technique the previous team used with a treadmill that takes the place of the roofing shingles which is ran at 9 mph to match the speed of the disk edge. This test will be conducted multiple times to identify the recommended distance the unit should be moved forward for optimum paint line quality.

### **7.1 Testing Plan**

The first round of tests are done by checking to see if the fully manufactured design meets the portability requirements and is fixable into the ground. In doing this the feasibility will be rated and depending on the rating, it will be determined if changes are needed after confirming the changes not causing too much of a burden in some redesign that may take place. First the team will test the portability with the unit fully assembled to see if the changes made that reduced the weight allow for the entire unit to be moved feasibly as one. If this cannot be done, the next step will be to see how feasible the design can be transported with the unit that sits on top of the lift table separated from the lift table. This alternative test involves separately transporting the lift table and the rest of the design and seeing how feasibly they can be rejoined when ready to be operated. Lastly the entire assembly is mounted into the ground with fasteners going through the base of the lift table into the ground and the team will observe to see how it holds.

The second round of tests include ensuring that structural integrity is maintained when the motor is in operation so that it can be assured the components are meshed together properly for all variations of motor speed. Since the motor is almost guaranteed to cause the entire design to vibrate, the objective is to make sure that none of the components are overstressed by the vibration with the way the device has been designed. From that the aim is to have the fasteners remain intact for prolonged use of the motor. The way this is planned is to have the motor run for a certain period of time at a speed of 260 RPM to get a disk edge speed of 800 fpm and observe how the structure holds up in at its initial position for a period of time. The same thing will be repeated for different increments of unit position change with the mill table and lift table in an effort to seek out which outward distances and height start to show problems that arise from the motor running.

The third and final round of testing is done with checking to see how well the design applies a line of paint using the same treadmill the previous team used when the Pac-Man device was made. This will be done by running the treadmill at 9 mph and the motor at 260 RPM to get

800 fpm which is equivalent to 9.09 mph. Although the speed will be off by roughly 10%, the disk should not be hindered by too much depending on how intense the vibration from the motor is. Multiple tests will be done doing this with each test having a different distance that is changed with the mill table and the lift table. The goal of this test is to see how far out and high the tables needs to be adjusted for the best paint line quality. This will be followed by multiple tests to check for variation in paint line width as the optimum positioning is sought out.

#### Testing Resources Needed:

- Treadmill
- White paint for testing (Supplied by GAF)
- The proper electrical outlet for the motor in use
- Eye protection
- Wipes/Cleaning material

## **7.2 Testing Results**

The following explanations of each testing round correspond to the description of the testing plans for the completely assembled and powered design project. It should be first noted that the team faced some unfortunate circumstances with the testing and lost a lot of time to perform all planned tests as a result of the initial shaft and disk fitting fiasco.

#### First Round:

For the fixation into the ground, given the time shortage we faced, there was not enough time to take the wheeled lift table and modify it to where it could be fixed to the ground. We proceeded to other parts of testing upon that conclusion, but a recommendation for this problem is stated in the concluding paragraph of this report.

The choice of a lift table used for vertical position adjustment makes the design meet the portability requirement given the wheels used to transport the assembly on the ground. The design weight is not excessively heavy though some precautions should be taken, and the team was able to move the project around on a flat surface. We found that with the Pac-Man device mounted and fixed onto the portable lift table, all components held together well enough when moving it around. However, with this project, it is highly recommended that the user only move the design around while the Pac-Man device is lowered to the lift table's lowest position to avoid tipping and mitigate injury that could result from that.

#### Second Round:

Upon connecting the motor to the power box linked to the needed 120 V source, we were able to get the motor to operate normally when the speed control knob is set between 40 and 100. It was found that between the minimum and maximum speed, the motor does not cause the entire assembly to vibrate. This outcome eliminates the concern that the vibration would pose a hazard to the user, cause structural damage, and cause the entire assembly to fall over or make the lift table move its position on the ground. Additionally, when changing the positions of the lift table and the mill table, the motor was able to properly function while maintaining structural integrity.



Though ideally one would not adjust the vertical positioning during operation, this shows how reliable the structural integrity of the design is. However it's suggested not to adjust the mill table more than halfway to its maximum limits in either direction. The only issue that was encountered with the motor in operation was that some slight wobble was noticed on the output pulley. This was further inspected to find that there is a slight excess of clearance between the shaft and the pulley that may require another taper lock bushing like what was used on the disk.

### Third Round:

Given the limited amount of time we had to get the motor powered to a control box, we were only able to accomplish that on the day before the project was to be presented at the senior project expo at Cal Poly. As a result of this we were not able to test the effectiveness of the disk delivering a line of paint on the treadmill we planned on using.

## **Chapter 8: Project Management**

In this section, the overall approach to completion of the design project is discussed from the start of the first quarter to the end of the third quarter. A timeline is shown depicting the main deliverables that pertain to the project which is intended to use as a briefing to show how the project is progressing. A list of resources that are to be used in all phases of the project are displayed to elaborate on methods the team will utilize to meet the project goal. Furthermore, it states the responsibilities of each team member involved and concludes with the next step to follow from the completion of the current quarter.

### **8.1 Overall Design Process**

#### *First Quarter -*

The project began with the team introduction and the development of the project statement of work. During the introduction process, each team member is assigned responsibilities to the project and this was followed by reviewing the customer's requirements. Upon gathering a complete understanding, the next step was establishing a team contract by which the team follows mutually agreed upon rules. The remainder of the four weeks were spent communicating with GAF to review and confirm the task the team has been assigned to and development of the statement of work which requires client approval before proceeding. The statement of work involved customer, literature, and technical research and communicated the team's strategy and progress to the customer. Upon approval of the statement of work, the next step was the development of the preliminary design review, where ideation generation and finalization of a design concept took place with the use of brainstorming, Pugh matrices, and decision matrices. The preliminary design got documented with a report that covers all the content in the preliminary design review which was submitted to GAF for approval to proceed with the project. The quarter concluded with Failure Mode and Effects Analysis which is evaluated based on the final concept prototype to seek out any hazards that should be accounted for and dealt with for future development.

### *Second Quarter -*

The project transitioned to critical design analysis where it was further evaluated to make the necessary changes to allow for the team to meet its goals. The first deliverable in this process was the Interim Design Review. This is an informal presentation to the class about the project and all the major decisions. Once all major and key decisions were confirmed, the team then proceeded to the construction of a structural prototype which will be used to establish the foundation of another prototype. This was to be a functional prototype that is designed to carry out the designated function based on how the structural prototype was designed. This is done so that feasible methods for assembly and component manufacturing can be sought out. The next phase was the Critical Design Review which is the continuation of the Preliminary Design Review from the first quarter but done with deeper analysis to finalize the design. After the team agreed to the final design, risk assessment was conducted to identify any hazards that may cause harm to the user. This is accounted for so that the team can find ways to mitigate any safety hazards and make any necessary changes until the design can be finalized and reassessed with optimum safety. The quarter ended with a manufacturing and test review where the team shows the manufacturing status and provides details on how testing the design's function was conducted.

### *Third Quarter -*

In the third quarter, the prototype is complete, and the team has completed the manufacturing and test review that was initiated in the second quarter. Throughout most of the quarter, the team sought out the most efficient methods to manufacturing the components to the project as well as continuous testing which is intended to ensure safety to the user and that it functions as designed. Upon completion of the project, the Final Design Review and the design at the Senior Project Expo have been presented.

## **8.2 Timeline**

The key deliverables, as shown in Table 8.1, divide the project year into three quarters. Each quarter has been broken down with milestones so that progress can be charted. Ricardo Quiroz will be notified of upcoming deadlines and events of review. In order to collaborate on a timely matter to meet deadlines, a Gantt chart was created and attached in Appendix D.

Table 8.1. Quarterly Key Deliverables

<b>Quarter 1</b>	<b>Quarter 2</b>	<b>Quarter 3</b>
Statement of Work	Interim Design Review	Hardware & Safety Demo
Preliminary Design Review	Critical Design Review	Final Design Review
-	Manufacturing & Test Review	Senior Project Expo

### 8.3 Special Techniques

This team has been organized with roles for each member, as follows:

Project Manager - Sidney Wong

Treasurer - Aaron Fisher

Manufacturing - Taylor Best

Testing - Aaron Fisher

Editor – All members

Throughout the year long project, the team will have access to useful resources to aid in making progress on the design. These resources include software, engineering approaches, and other non-technical resources. Software will be useful mostly for calculations, communicating results with graphic images, data analysis, and iterations. The team will take advantage engineering approaches learned in previous classes that pertain to the objectives of the design project so that the customer's requirements are mapped out. Lastly, campus resources are available for non-technical issues related to the project for issues like prototypes, advice, and planning. Table 8.2 below shows the specific resources that will be available to the team.

Table 8.2. Available Project Resources

<b>Software</b>	<b>Engineering Approaches</b>	<b>Campus Resources</b>
SolidWorks	Mechanics of Materials	Campus Workshops
MATLAB	Statics/Dynamics	Campus Travel Funding
Adams View	Design Mechanics	Senior Project Advisor Assistance

With distribution of responsibilities, and resources available to the team, it is expected that every member has an opportunity to lead a different aspect of the project. A team contract was also created so that all team members will abide to agreements listed as a set of structured operations for procedures

## **Chapter 9: Conclusions & Recommendations**

The document is meant to show how the team concluded the design project from the preliminary design phase. It further details on the final concept design with some additional changes deemed necessary by the team in order to effectively meet the design goals. Additionally, provides insight on what materials, expenditures, and manufacturing processes will be required to meet the goal of the design. In the previous phase of the design process, calculations were done to obtain the dimensions and other parameters that would be necessary and validated before the team could declare the design to be realistically manufactured. Overall this gives the entire scope of the reexamined and improved design concept to show how certain features needed to be changed and why some features remained intact. With the testing that the team was able to accomplish, it can be concluded that most design requirements have been met except for those that were not met due to the time shortage encountered. Additionally, the project was completed well within the allowed budget. In concluding the project, some recommendations should be made before testing this prototype on an actual roll of moving roofing shingles. Since the design does not have a way to be fixed to the ground, we recommend designing a slot like structure that gets fixed into position next to the roofing shingles so that the lift table can slide right into it and be fixed with it.

## **References:**

- [1] *Spiral Lift Mechanical Scissor Lifts*, Autoquip, Accessed 31 Jan. 2018.  
<https://www.autoquip.com/Products/mechanical-lifts/spiral-scissor-mechanical/>.
- [2] *L200 - Heavy Duty Lab Jack*, Thorlabs, Accessed 29 Jan. 2018.  
<https://www.thorlabs.com/thorproduct.cfm?partnumber=L490#ad-image-0>.
- [3] *Gearmotors*, Worldwide Electric, Accessed 30 Jan. 2018.  
<https://www.worldwideelectric.net/product-category/gear-reducers/garmotors/>.
- [4] Rosoff, Dean, and Stanley Rosoff. *Timing Belts*, Dealer Automotive Services, Accessed 3 Mar. 2018. <https://www.dealerautomotive.com/product/timing-belts-hopkins-mn/>.
- [5] *Chain Drive*, Muscle Car DIY, 29 May 2016, Accessed 1 Mar. 2018.  
<https://www.musclecardiy.com/performance/how-to-blueprint-engines-timing-systems-guide/>.
- [6] Long; William T, Krueger; David E, and Paddock; Ryan Evan. 2NDSTORYPLUS, LLC. Patent 9637361. 17 Jun. 2017.
- [7] Shigley, Joseph Edward. *Mechanical Engineering Design*. North Ryde, N.S.W.: McGraw-Hill Australia, 2007. Print



## Appendix B: Decision Matrices

Legend	
+	Good
o	Neutral
-	Bad
*	Varies

Table B-1. Legend that defines each symbol used in the Pugh matrices when ranking each function.

### Shaft Configuration

Objective	Parallel	Perpendicular
Spatial Requirements	*	*
Simplicity (eg. Number of Components)	+	o
Ease of Maintenance	+	-

Figure B-2. Pugh matrix used in deciding which shaft configuration would be most feasible for the design.

### Drivetrain

Objective	Gears	Belt	Chain
Cost	+	o	-
Reliability	+	-	o
Ease of Maintenance	+	-	o
Efficiency	+	-	o
Simplicity	o	+	+
Durability	+	-	o

Figure B-3. Pugh matrix used in deciding which drivetrain would be most feasible to incorporate.

<b>Concept Selection</b>					
<b>Objective</b>	<b>Raw Score (1-5)</b>		<b>Weight Factor</b>	<b>Weighted Score</b>	
	<b>Concept 1</b>	<b>Concept 2</b>		<b>Concept 1</b>	<b>Concept 2</b>
Portability	4	4	3	12	12
Ease of Maintenance	4	5	4	16	20
Simplicity	4	5	4	16	20
Durability	4	4	4	16	16
Meet Spatial Requirements	5	4	5	25	20
Safe Use	5	5	5	25	25
			<b>Total</b>	110	113

Figure B-4. Weighted decision matrix used for selecting the proposed design that best meets design requirements with relation to the design objectives.



## Appendix C: Final Analyses/Testing Details

### C.1 Critical Speed Analysis (Shaft)-

Critical Speed

- Critical speed analysis only focuses on weight between the two bearings. The weight of the pulley outside of the bearing is negligible compared to the disk.

Schematic: (Not to Scale)

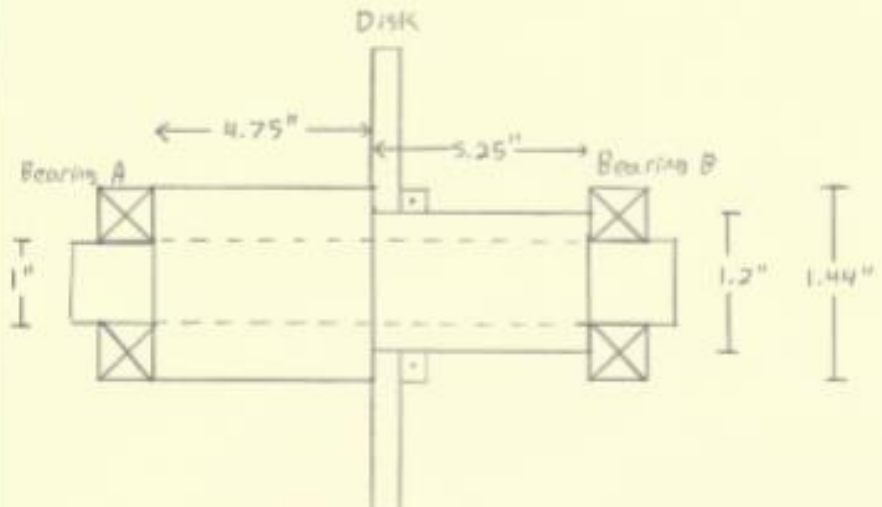

The schematic shows a horizontal shaft supported by two bearings, Bearing A on the left and Bearing B on the right. A vertical disk is mounted on the shaft between the bearings. The distance from Bearing A to the disk is 4.75 inches, and the distance from the disk to Bearing B is 5.25 inches. The shaft has a diameter of 1 inch. The disk has a diameter of 1.2 inches. The bearings have a diameter of 1.44 inches.

- The analysis is done by assuming the shaft to be a uniform 1 inch diameter shaft and the larger diameters will be the weight difference.
- The weights will all be accounted for and a Free body diagram is drawn to show where the loads take place.

FBD:

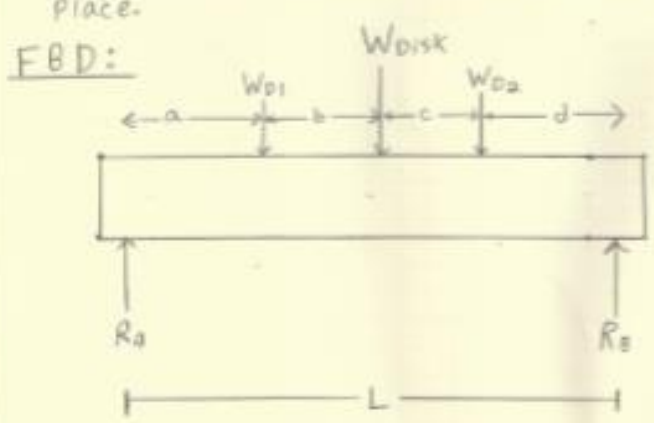

The FBD shows a horizontal bar representing the shaft. The total length of the shaft is  $L$ . The weight of the disk,  $W_{Disk}$ , is shown as a downward force at the center. The weight of the shaft between Bearing A and the disk,  $W_{01}$ , is shown as a downward force at a distance  $a$  from Bearing A. The weight of the shaft between the disk and Bearing B,  $W_{02}$ , is shown as a downward force at a distance  $c$  from the disk. The reaction forces at the bearings are  $R_A$  at the left end and  $R_B$  at the right end.

Data:  $E = 29,700 \text{ ksi}$   
 $L = 10''$   $\rho_{\text{steel}} = 0.284 \text{ lbf/in}^3 = \rho$   
 $D_1 = 1.44''$   $L_{01} = 4.75''$   $a = 2.375''$   
 $D_2 = 1.2''$   $L_{02} = 5.25''$   $b = 2.75''$   
 $D_3 = 1.0''$   $W_{\text{disk}} = 12.35 \text{ lbf}$   $c = 2.25''$   
Analysis:  $d = 2.625''$

• The analysis will be handwritten in symbolic form and will then be calculated numerically using MATLAB.

Weight:

$$W_{01} = \rho V_{01}$$

$$V_{01} = A_{01} L_{01}$$

$$A_{01} = \frac{\pi (D_1 - D_3)^2}{4}$$

$$W_{02} = \rho V_{02}$$

$$V_{02} = A_{02} L_{02}$$

$$A_{02} = \frac{\pi (D_2 - D_3)^2}{4}$$

Critical speed: (Shigleys used)

$$W_{cr} = \sqrt{\frac{g \sum W_i y_i}{\sum W_i y_i^2}}$$

$$W_{cr} = \left( \frac{g [W_{01} y_{01} + W_{02} y_{02} + W_{\text{disk}} y_{\text{disk}}]}{W_{01} y_{01}^2 + W_{02} y_{02}^2 + W_{\text{disk}} y_{\text{disk}}^2} \right)^{\frac{1}{2}}$$

$$y_{01} = W_{01} \delta_{11} + W_{02} \delta_{12} + W_{\text{disk}} \delta_{13} \quad \text{in}$$

$$y_{02} = W_{01} \delta_{21} + W_{02} \delta_{22} + W_{\text{disk}} \delta_{23} \quad \text{in}$$

$$y_{\text{disk}} = W_{01} \delta_{31} + W_{02} \delta_{32} + W_{\text{disk}} \delta_{33} \quad \text{in}$$

$$S_{11} = \frac{(L-a)(a)[L^2 - (L-a)^2 - a^2]}{6EIL} \quad \frac{1n}{16F}$$

$$S_{22} = \frac{(L-a+b)(a+b)[L^2 - (L-a+b)^2 - (a+b)^2]}{6EIL} \quad \frac{1n}{16F}$$

$$S_{33} = \frac{(L-a+b+c)(a+b+c)[L^2 - (L-a+b+c)^2 - (a+b+c)^2]}{6EIL} \quad \frac{1n}{16F}$$

$$S_{12} = \frac{(L-a+b)(a)[L^2 - (L-a+b)^2 - a^2]}{6EIL} \quad \frac{1n}{16F}$$

$$S_{21} = S_{12}$$

$$S_{23} = \frac{(L-a+b+c)(a+b)[L^2 - (L-a+b+c)^2 - (a+b)^2]}{6EIL} \quad \frac{1n}{16F}$$

$$S_{13} = \frac{(L-a+b+c)(a)[L^2 - (L-a+b+c)^2 - a^2]}{6EIL} \quad \frac{1n}{16F}$$

$$S_{31} = S_{13} \quad \frac{1n}{16F}$$

$$S_{32} = S_{23} \quad \frac{1n}{16F}$$

• The numbers are calculated with MATLAB

```
%Take the smallest diameter of the shaft and assume that to be the uniform
%shaft where the other step ups are treated as elements in addition to the
%pulley and disk. Get thier weight from the difference in volume from the
%smallest shaft diameter.
```

```
%Shaft Dimensions/Properties
```

```
d = 1; %in
Done = 1.44; %in
Dtwo = 1.2; %in
```

```
I =[(pi*d^4)/64]; %in
EM = 29700; %ksi
E = EM*1000;
g = 386.4 %in/s^2
Rho = 0.284; %lbf/in^3
```

```
L = 10; %ft
LDone = 4.75; %in
LDtwo = 5.25; %in
Wdisk = 12.35 %in
```

```
%Diameter properties for weight analysis
```

```
ADone = pi*[(Done - d)^2]/4; %in^2
VDone = ADone*LDone; %in^3
```

```
ADtwo = pi*[(Dtwo - d)^2]/4; %in^2
VDtwo = ADtwo*LDtwo; %in^3
```

```
%Element Weights
```

```
Wone = Rho*VDone; %lbf
Wtwo = Rho*VDtwo; %lbf
```

```
%Load distances
```

```
a = 2.375; %in
b = 2.75 %in
c = 2.25 %in
d = 2.625 %in
```

```

%Load Influence Coefficients

deloo = (L-a)*(a)*[L^2 - (L-a)^2 - a^2]/(6*E*I*L); %in/lbf
delot = (L-a+b)*(a)*[L^2 - (L-a+b)^2 - a^2]/((-1)*6*E*I*L); %in/lbf
deloth = (L-a+b+c)*(a)*[L^2 - (L-a+b+c)^2 - a^2]/((-1)*6*E*I*L); %in/lbf

delto = delot;
deltt = (L-a+b)*(a+b)*[L^2 - (L-a+b)^2 - (a+b)^2]/((-1)*6*E*I*L); %in/lbf
delthh = (L-a+b+c)*(a+b)*[L^2 - (L-a+b+c)^2 - (a+b)^2]/((-1)*6*E*I*L); %in/lbf

deltho = deloth;
deltht = delthh;
delthth = (L-a+b+c)*(a+b+c)*[L^2 - (L-a+b+c)^2 - (a+b+c)^2]/((-1)*6*E*I*L); %in/lbf

%Deflections

YDone = Wone*deloo + Wtwo*delot + Wdisk*deloth; %in
YDtwo = Wone*delto + Wtwo*deltt + Wdisk*delthh; %in
Ydisk =Wone*deltho + Wtwo*deltht + Wdisk*delthth; %in

%Critical Speed

A = Wone*YDone + Wtwo*YDtwo + Wdisk*Ydisk; %lbf*in
B = Wone*(YDone^2) + Wtwo*(YDtwo^2) + Wdisk*(Ydisk^2); %lbf*in

Wcr = sqrt(g*A/B)

```

Wcr =

507.8612

## C.2 Notch Radius Analysis (Shaft)-

Stress Factor:

$$K_{ts} = 1.4$$

- The figure used for determining the appropriate notch radius for all of the steps in our shaft are found in figure A-15-8 on pg 1036 of Shigley's.

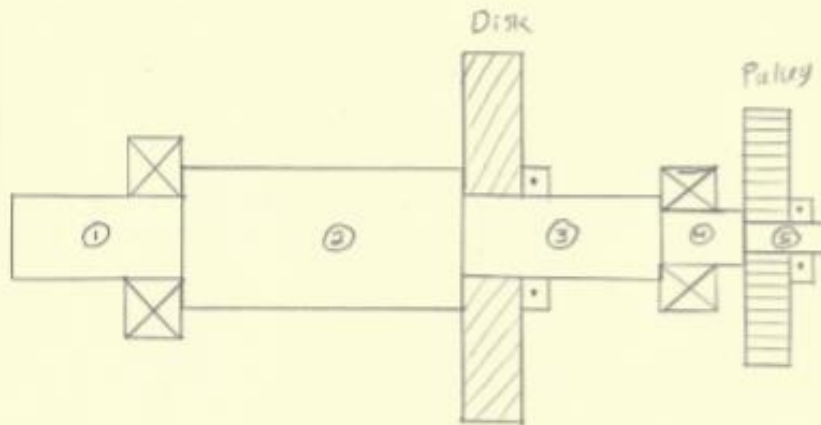

Data:

Diameter	Size
①	1.000"
②	1.440"
③	1.200"
④	1.000"
⑤	0.875"

- The notch radius analysis will be done from the left to the right.

$$d_1 : D_2 -$$

$$\frac{D_2}{d_1} = \frac{1.44 \text{ in}}{1.00 \text{ in}} = 1.44$$

- On the figure where  $K_{ts} = 1.4$  we get  $\frac{r}{d_1}$  of approximately 0.068.

$$\frac{r}{d_1} = 0.068 \Rightarrow r = 0.068 d_1 = 0.068 (1.00) \text{ in}$$

$$\underline{r = 0.068 \text{ inches}}, \text{ between } D_1 \text{ and } D_2$$

$d_3 : D_2 -$

$$\frac{D_2}{d_3} = \frac{1.44 \text{ in}}{1.20 \text{ in}} = 1.2$$

- On the figure where  $K_{ts} = 1.4$  we get  $\frac{r}{d}$  of approximately 0.03125.

$$\frac{r}{d_3} = 0.03125 \Rightarrow r = 0.03125 d_3 = 0.03125(1.2) \text{ in}$$

$$\underline{r = 0.0375 \text{ inches}}, \text{ between } D_2 \text{ and } D_3$$

$d_4 : D_3 -$

$$\frac{D_3}{d_4} = \frac{1.2 \text{ in}}{1.0 \text{ in}} = 1.2$$

- On the figure where  $K_{ts} = 1.4$  we get  $\frac{r}{d}$  of approximately 0.05225.

$$\frac{r}{d_4} = 0.05225 \Rightarrow r = 0.05225 d_4 = 0.05225(1.0) \text{ in}$$

$$\underline{r = 0.05225 \text{ inches}}, \text{ between } D_3 \text{ and } D_4$$

$d_5 : D_4 -$

$$\frac{D_4}{d_5} = \frac{1.000 \text{ in}}{0.875 \text{ in}} = 1.143$$

- On the figure where  $K_{ts} = 1.4$  we get  $\frac{r}{d}$  of approximately 0.0325.

$$\frac{r}{d_5} = 0.0325 \Rightarrow r = 0.0325 d_5 = 0.0325(0.875) \text{ in}$$

$$\underline{r = 0.0284 \text{ inches}}, \text{ between } D_4 \text{ and } D_5$$

Calc's

Notch Radii

Bending

Stress Factor:

$$K_t = 1.6$$

- The figure used for determining the appropriate notch radius for all of the steps in our shaft are found in figure A-15-9 on pg 1036 of shigleys.

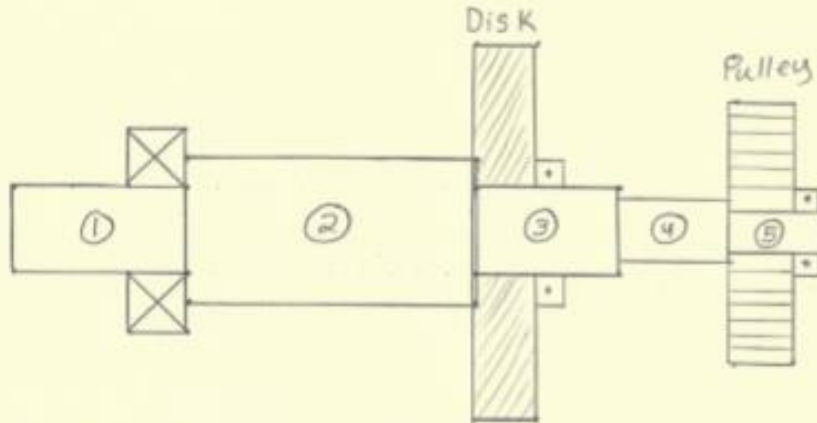

Data:

Diameter	size
①	1.000"
②	1.440"
③	1.250"
④	1.000"
⑤	0.875"

- The notch radius analysis will be done from the left to the right.

$$d_1 : D_2 -$$

$$\frac{D_2}{d_1} = \frac{1.440}{1.000} = 1.44$$

- On the figure where  $K_t = 1.6$  we get  $\frac{r}{d}$  of approximately 0.075 ←

$$\frac{r}{d_1} = 0.075 \Rightarrow r = 0.075d_1 = 0.075(1.0) \text{ in}$$

$$\underline{r = 0.075 \text{ inches}}, \text{ between } D_1 \text{ and } D_2$$



$d_3 : D_2 -$

$$\frac{D_2}{d_3} = \frac{1.44}{1.25} = 1.152$$

- On the figure where  $K_t = 1.6$  we get  $\frac{r}{d}$  of approximately 0.06125

$$\frac{r}{d_3} = 0.06125 \Rightarrow r = 0.06125d_3 = 0.06125(1.25) \text{ in}$$

$r = 0.0766 \text{ inches}$ , between  $D_2$  and  $D_3$

$d_4 : D_3 -$

$$\frac{D_3}{d_4} = \frac{1.25}{1.00} = 1.25$$

- On the figure where  $K_t = 1.6$  we get  $\frac{r}{d}$  of approximately 0.07

$$\frac{r}{d_4} = 0.07 \Rightarrow r = 0.07d_4 = 0.07(1.0) \text{ in}$$

$r = 0.07 \text{ inches}$ , between  $D_1$  and  $D_2$

$d_5 : D_4 -$

$$\frac{D_4}{d_5} = \frac{1.000}{0.875} = 1.143$$

- On the figure where  $K_t = 1.6$  we get  $\frac{r}{d}$  of approximately 0.06

$$\frac{r}{d_5} = 0.06 \Rightarrow r = 0.06d_5 = 0.06(0.875) \text{ in}$$

$r = 0.0525 \text{ inches}$ , between  $D_4$  and  $D_5$

C.3 Shaft Sizing Calculations -

$R_{Pt} = \dots @ \dots$   
 $R_{Py} = \sin(\dots) R_{Pt}$   
 $R_{Px} = \cos(\dots) R_{Pt}$   
 $D/d = 1.2$

$$\sum F_x = R_{Ax} - R_{Bx} + R_{Px} = 0$$

$$\sum F_y = R_{Ay} - R_{Pcy} + R_{By} - R_{Py} = 0$$

$$\sum M_A = -R_{Bx}(z_B) + R_{Px}(z_P) = 0$$

$$R_{Bx} = R_{Px} \frac{z_P}{z_B}$$

$$\sum M_{Ay} = -R_{Pcy}(z_{Pcy}) + R_{By}(z_{By}) - R_{Py}(z_P) = 0$$

$$R_{By} = R_{Pcy} \frac{z_{Pcy}}{z_B} + R_{Py} \frac{z_P}{z_B}$$

$$\sum F_x: R_{Ax} = R_{Bx} - R_{Px}$$

$$\sum F_y: R_{Ay} = R_{Pcy} - R_{By} + R_{Py}$$

assume:  
 1020 CD Steel  $S_{ut} = 68 \text{ ksi}$  Pg 34  
 $S_e = 0.5 S_{ut}$   
 $S_e = K_a K_b K_c K_d K_e S_e'$   
 $K_a = a S_{ut}^b \rightarrow a = 2.7 \quad b = -0.265$   
 $K_b \approx 0.9$   
 $K_c = K_d = K_e = 1$   
 Assume:  
 $K_f = K_g = 1.6$   
 $K_H = K_B = 1.4$

$$\sigma_a' = (\sigma_a^2 + 3\tau_a^2)^{1/2} \quad \sigma_m' = (\sigma_m^2 + 3\tau_m^2)^{1/2}$$

$$\frac{1}{n} = \frac{\sigma_a'}{S_e} + \frac{\sigma_m'}{S_{ut}}$$

$$\sigma_a = K_f \frac{32 M_m}{\pi d^3} \quad \sigma_m = K_f \frac{32 M_m}{\pi d^3}$$

$$\tau_a = K_{fs} \frac{16 T_m}{\pi d^3} \quad \tau_m = K_{fs} \frac{16 T_m}{\pi d^3}$$

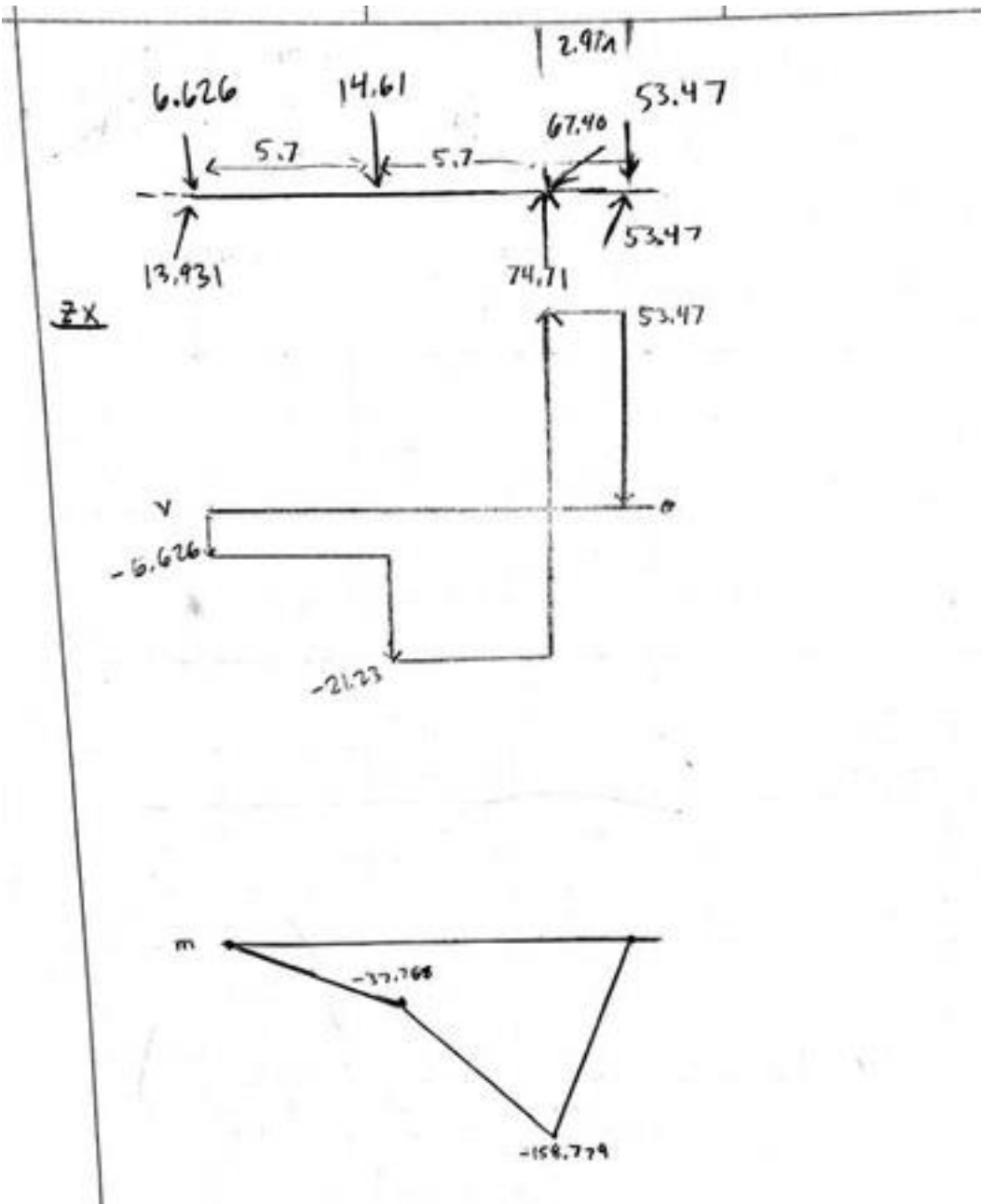

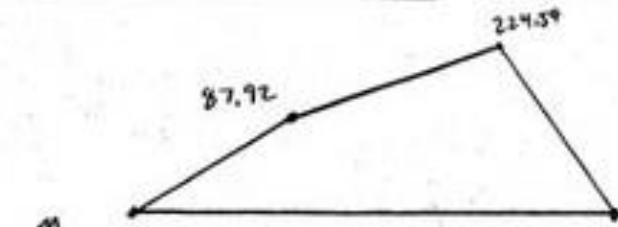
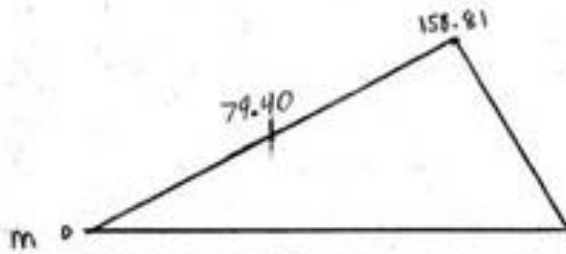
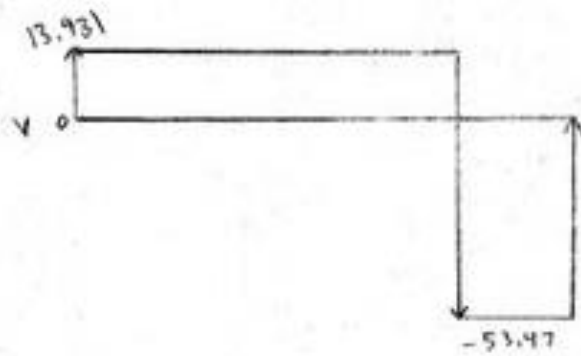
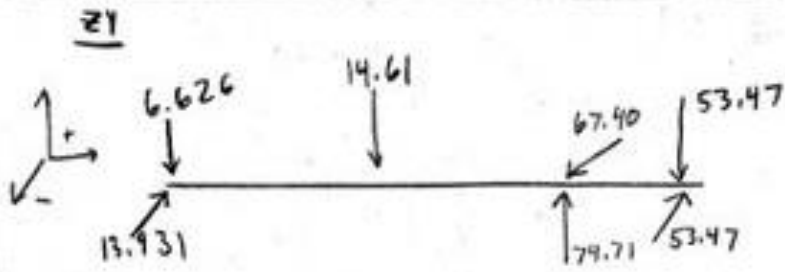

$M$   
total

$$M_a = 224.57 \text{ lb}\cdot\text{in} = 18.71 \text{ lb}\cdot\text{ft}$$

$$\bar{T}_m = T_m \cdot N = 6 \text{ ft} \cdot 16 \cdot 2.91 = 17.46 \text{ ft}\cdot\text{lb}$$

# Mechanical Paint Line Test Stand User Manual

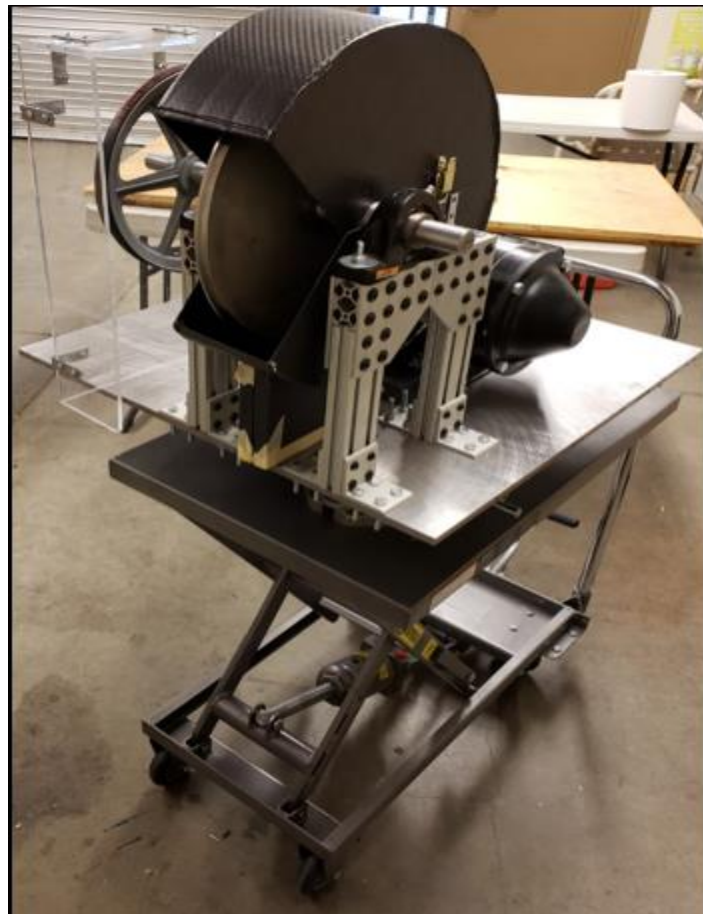

By:

Aaron Fisher

Sidney Wong

Taylor Best

## **Table of Contents:**

### **1. Structural Integrity**

- a. Leg security
- b. Pac-Man housing security
- c. Motor and mount security
- d. Shaft integrity
- e. Lift Table functionality
- f. Mill Table functionality

### **2. Component Operational Instructions**

- a. Mill Table
- b. Lift Table
- c. Opening/Closing Pac-Man housing
- d. Motor Mount instructions
- e. Activation of the motor.

### **3. Assembly Operational Instructions**

- a. Initial Positioning
- b. Vertical Adjustment
- c. Test contact before operation
- d. Adding paint
- e. VFD instructions for operation
- f. Paint application procedure

#### 4. Maintenance and Replacing Parts

- a. Paint disposal
- b. Bearing maintenance
- c. Mill Table maintenance
- d. Belt preservation
- e. Component replacement

## **Mechanical Paint Line Test Stand Instructions:**

The following content describes the instructions on how to set up and operate the Mechanical Paint Line Test Stand. Please follow the instructions in the order presented in the Table of Contents and also acknowledge the safety warnings:

**Note:** This device is primarily used for the application of a paint line on a moving roll of roofing shingles and must not be used for anything else for safety reasons.

### 1. Structural Integrity:

Verify that the components are all in tact together before proceeding to operation. The following should be checked:

- a. Both legs are secure to the base plate, there should be no wobbling.
- b. The Pac-Man housing is fixed in place so that it does not rotate or slide along the shaft.
- c. The motor mount is properly fixed onto the plate and the motor is able to slide on the mount without being removed.
- d. While belt is not tensioned, rotate the shaft with your hand to see how the disk rotates freely.

**WARNING:** If the disk or shaft show a lot of resistance or does not rotate at all, do not use this device.

- e. Make sure lift table adjusts properly to its full capacity in both vertical directions.



- f. Make sure mill table at the bottom of baseplate is able to adjust in both of the longitudinal and lateral directions without any jamming.

**WARNING:** If the mill table jams in either direction do not use this device.

**WARNING:** Do not move the mill table to its max limits, as this increases the risk of a crush hazard from the Pac-Man device tilting over.

#### 4. Component Operational Instruction

Follow the instructions below to know how to operate the individual components of the Paint Line Test Stand. Make sure to acknowledge the warnings in each segment.

- a. To adjust the Pac-Man device longitudinally and laterally, the mill table has two knobs for each direction desired. To make longitudinal adjustments (forward and backwards) as shown in the figure below, use the knob that rotates about the forward and backwards directions of the Pac-Man device. To make lateral adjustments (left and right) as shown in the second figure below, use the knob that rotates about the left and right directions of the Pac-Man device.

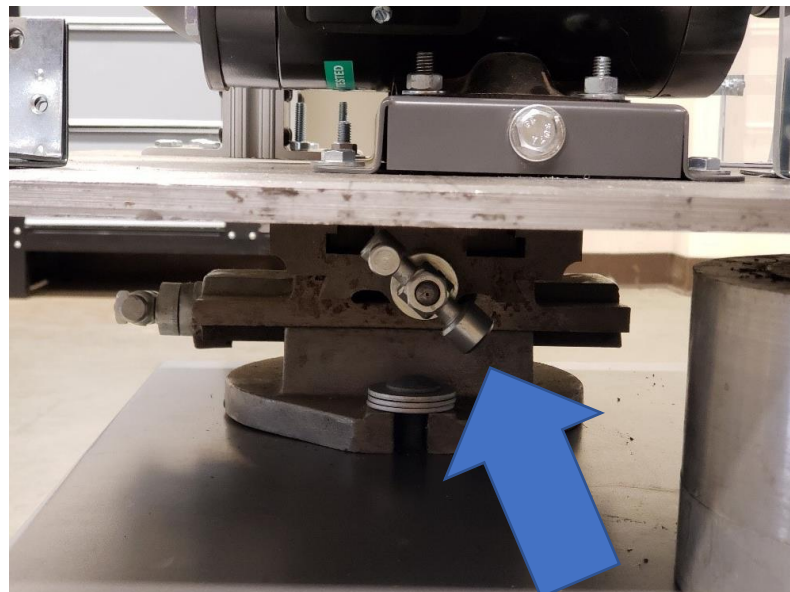

- b. To raise the height of the lift table, use your foot to press down on the foot lever then release and press down again once the foot lever has returned to its original height. Do this continuously until you have reached your desired height for the Pac-Man device. To lower the height of the lift table, use the hand lever to the right of the push handle and gradually pull it inwards to lower the table.

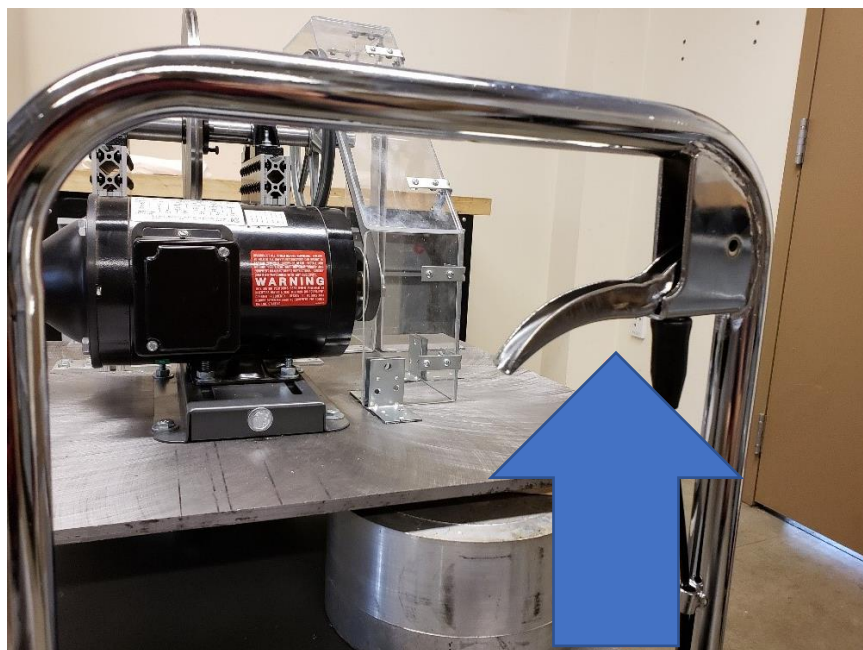
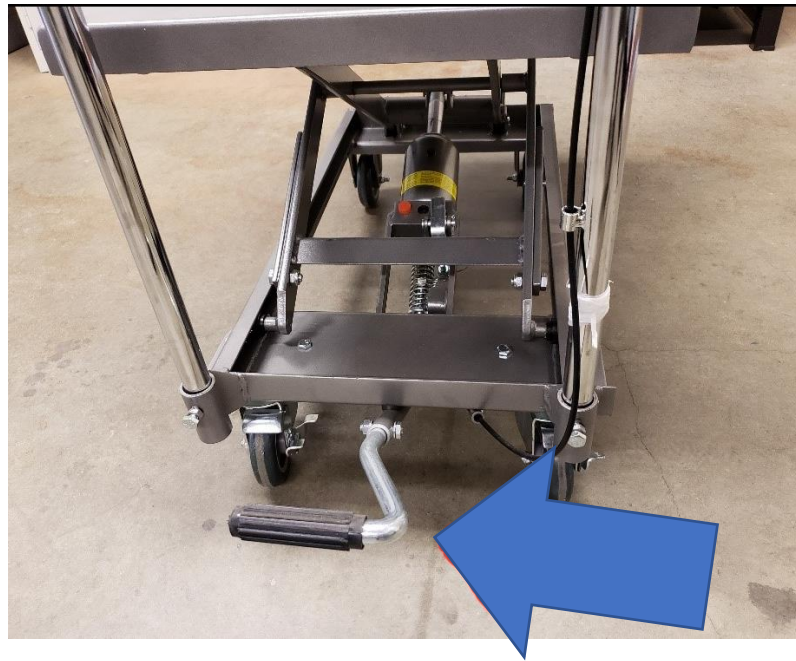

**Warning:** Do not pull on the lever fast as this will cause the lift table to drop quickly and the heavy load on top of the table may cause damage to the lower components of the lift table and potentially injure the user. For safest use, slowly lower the lift table with a gradual pull of the lever.

- c. To add the Pac-Man housing to the Pac-Man device, open the housing and place it into the device so that the bore to the housing encloses the shaft when the housing is closed. Make sure the metal tabs around the housing are mounted on top of the aluminum extrusion as shown by the blue arrow. Finally close down both latches and fasten down the black fasteners where the housing is positioned so that they compress on the tabs and hold them in place.

To remove the Pac-Man housing, loosen the black fasteners to release the metal tabs and then open both latches so that the housing can be opened and removed from the device. Slowly remove the housing from that point.



- d. The motor mount is used to add and remove tension in the belt of the Pac-Man devices drive train. Before tightening or loosening make sure the belt is positioned on both pulleys. To tighten it take a wrench that fits around the aft most nut

and crank it clockwise to move the motor away from the Pac-Man device. To loosen it crank it counter clockwise to move it towards the Pac-Man device. The nut used for adjusting is shown in the figure below.



- e. To turn on the motor, first make sure make sure the speed control box is plugged into a power source. Once verified turn the switch to the on position starting at 40 and adjust the speed using the knob shown in the figure. Flip the switch to the off position when finished using.



**Warning:** Do not start the motor at a speed below 40 or this will overload the circuit in the control box. Only vary the speed between 40 and 100 when operational.

### 3. Assembly Operational Instructions:

After programming the Control Box for the motor, the device is now ready to use and the following steps are to be followed:

- a. Place the Mechanical Paint Line Test Stand in position so that the edge of the disk is anywhere from 1 inch to 2 inches close to the roll of roofing shingles to be painted.

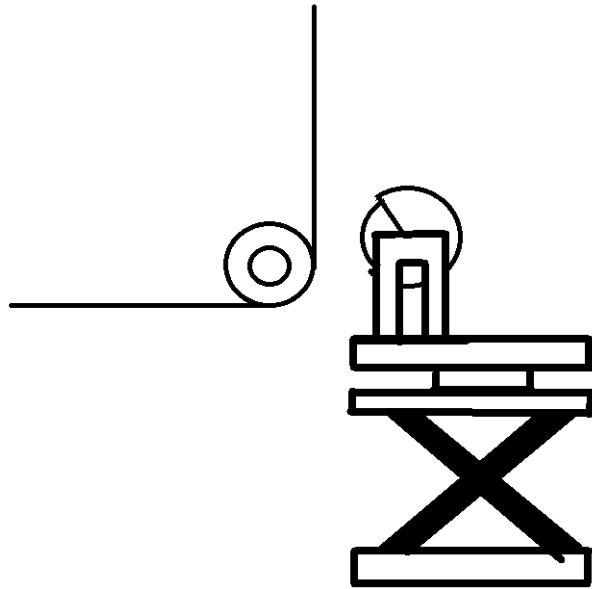

- b. Adjust lift table to the desirable height.
- c. Move the non-active disk towards the roofing shingles using the mill table to make contact, and reposition or rotate the device as needed so that the edge of the disk is flush with the roofing shingles. Then move the device back to its original position.

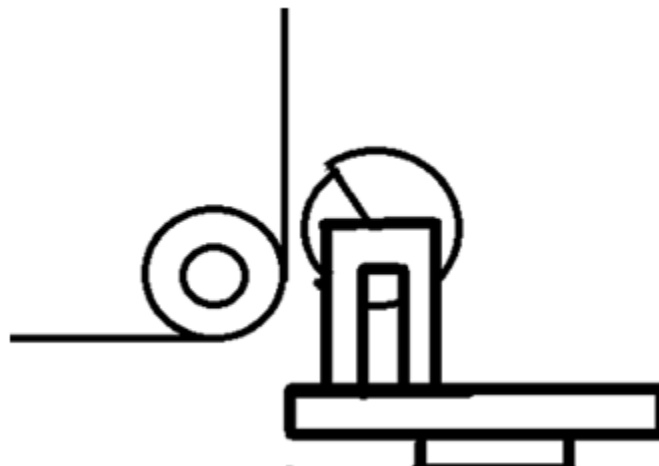

- d. Pour paint into the Pac-Man housing so that it fills  $\frac{1}{4}$  of the volume of the lower half of the housing.

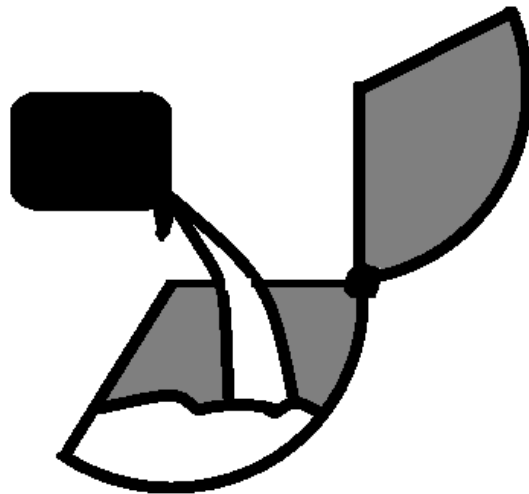

- e. Activate the motor so that it operates at 260 RPM to match the speed of the roofing shingles roll.
- f. Once the test stand is operational, slowly adjust the Pac-Man device towards the moving roofing shingles with the mill table until the disk comes in contact with it.

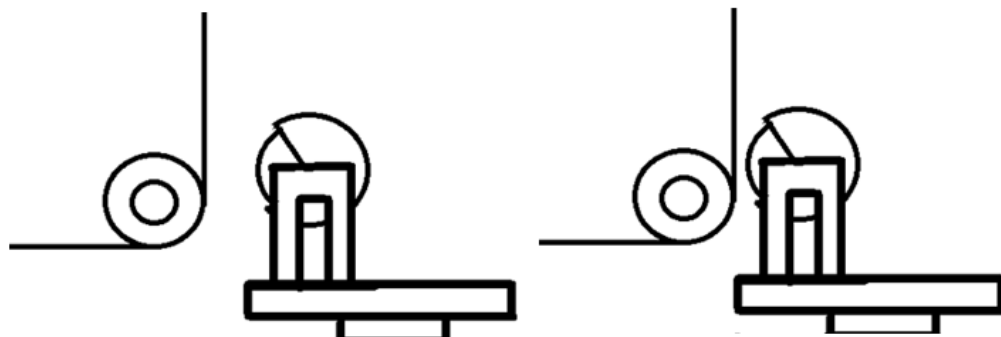

#### 4. Maintenance and Replacing Parts:

After use or when parts begin to fail complete the following:

- a. Remove the Pac-Man housing with the paint in it by opening the latches on both sides and properly dispose of the paint. Wipe off and dry the disk and the part of the shaft that has



been covered in paint to prevent it from drying on the surface and potentially causing corrosion.

- b. Depending on the frequency and duration of each use, monitor the performance of the bearings. If resistance of shaft rotation shows, it may need more grease added to maintain smooth rotation.
- c. If the device is operating in a dusty environment, it is advisable that the mill table slots be lubricated to prevent jamming between each use.
- d. To make the belt last longer, do not leave it tensioned on the motor mount. At the end of the session, release the motor mount to relieve the belt of the tension.
- e. If any parts need to be replaced, refer to the procurements section on the final page to reorder those parts and properly dispose of the broken parts.

## Appendix E: Safety Hazard

### DESIGN HAZARD CHECKLIST

Team: Team 5: The White Stripes Advisor: Dr. Elghandour Date: 03/08/2018

Y N

- ✓  1. Will the system include hazardous revolving, running, rolling, or mixing actions?
- ✓ 2. Will the system include hazardous reciprocating, shearing, punching, pressing, squeezing, drawing, or cutting actions?
- ✓ 3. Will any part of the design undergo high accelerations/decelerations?
- ✓  4. Will the system have any large (>5 kg) moving masses or large (>250 N) forces?
- ✓  5. Could the system produce a projectile?
- ✓  6. Could the system fall (due to gravity), creating injury?
- ✓ 7. Will a user be exposed to overhanging weights as part of the design?
- ✓  8. Will the system have any burrs, sharp edges, shear points, or pinch points?
- ✓ 9. Will any part of the electrical systems not be grounded?
- ✓ 10. Will there be any large batteries (over 30 V)?
- ✓  11. Will there be any exposed electrical connections in the system (over 40 V)?
- ✓ 12. Will there be any stored energy in the system such as flywheels, hanging weights or pressurized fluids/gases?
- ✓ 13. Will there be any explosive or flammable liquids, gases, or small particle fuel as part of the system?
- ✓ 14. Will the user be required to exert any abnormal effort or experience any abnormal physical posture during the use of the design?
- ✓ 15. Will there be any materials known to be hazardous to humans involved in either the design or its manufacturing?
- ✓ 16. Could the system generate high levels (>90 dBA) of noise?
- ✓ 17. Will the device/system be exposed to extreme environmental conditions such as fog, humidity, or cold/high temperatures, during normal use?
- ✓  18. Is it possible for the system to be used in an unsafe manner?
- ✓  19. For powered systems, is there an emergency stop button?
- ✓ 20. Will there be any other potential hazards not listed above? If yes, please explain on reverse.

Figure F-1. Check list of the design's hazards to be made aware of for the customer.

Description of Hazard	Planned Corrective Action	Planned Date	Actual Date
1) Since the system will be belt driven, there is a possibility for the system to have an exposed belt.	Moving parts shall be enclosed in a housing.	10/04/18	10/04/18
4) The Pac-Man device has a large rotating aluminum disk that applies the paint to the shingles.	The disk is enclosed in the Pac-Man shaped housing	05/24/18	05/24/18
5) In case of a belt failure, the belt may be flung away from the pulleys.	Moving parts shall be enclosed in a housing.	10/04/18	10/04/18
6) The entire Pac-Man assembly will be raised and lowered with a vertically adjustable table. Raising this heavy of a weight would make the assembly prone to tipping.	The overall layout of the design will attempt to center the weight as much as possible. Also, the table will be mounted to the ground.	10/11/18	10/11/18
8) Test and support stands may include sharp edges and pinch points, as described in Description 2.	Pinch points shall be covered by bellows. Sharp edges shall be grinded down and rounded off.	11/29/18	11/29/18
11) The motor speed controller and power supply may have exposed wiring.	All wiring and electrical components shall be protected by a housing	11/30/18	11/29/18
18) The system, having several moving parts, could be used in an unsafe manner if the user was to put themselves in harm's way.	All moving parts with the potential for causing bodily harm shall be enclosed. The device will be designed to be intuitive to operate.	10/04/18	10/04/18
19) In case of emergency, all moving parts may have to be stopped quickly.	The system must include emergency stopping features for all components that may require it to comply with OSHA requirements.	11/29/18	11/29/18

Figure F-2. List of hazards described and the necessary corrective actions to be taken.

# Appendix F: Gantt Chart

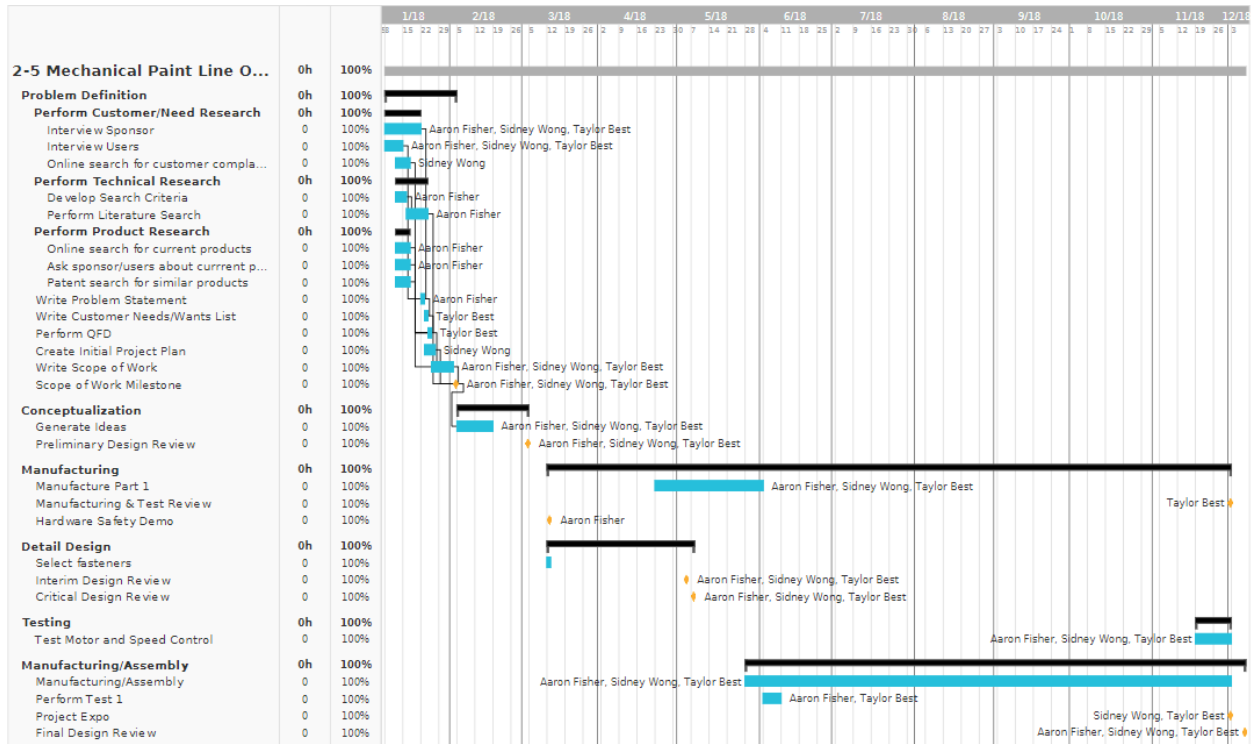

Figure G-1. Gantt Chart showing the senior project team’s agenda

**Appendix G: Complete Drawings Package**

Prefix	DWG #:	Suffix	Item:
-	0.00	-	Drawing List
M	1.00	A	Machine Assembly
M	1.01	EX	Machine Exploded
M	1.10	PT	Base Plate
S	2.00	A	Support Assembly
S	2.01	EX	Support Exploded
S	2.10	PT	Aluminum Extrusions
S	2.20	PT	Bearings
S	2.30	PT	L Brackets
S	2.40	PT	Corner Surface Brackets
S	2.50	PT	Inner Corner Brace Bracket
S	2.60	PT	Fastener 1
S	2.70	PT	Fastener 2
S	2.80	PT	Fastener 3
PM	3.00	A	Pac-Man Assembly
PM	3.01	EX	Pac-Man Exploded
PM	3.10	PT	Shaft Part
PM	3.20	PT	Disk Wheel
PM	3.30	PT	Key
PM	3.40	PT	9" Pulley
PMH	4.00	A	Pacman Housing Assembly
PMH	4.01	EX	Pacman Housing Exploded View
PMH	4.10	A	Pacman Housing Upper Assembly
PMH	4.11	EX	Pacman Housing Upper Exploded
PMH	4.12	PT	Pacman Housing Upper Sheet 1
PMH	4.13	PT	Pacman Housing Upper Sheet 2
PMH	4.20	A	Pacman Housing Lower Assembly
PMH	4.21	EX	Pacman Housing Lower Exploded
PMH	4.22	PT	Pacman Housing Lower Sheet 1
PMH	4.23	PT	Pacman Housing Lower Sheet 2
PMH	4.30	PT	Latches
DT	5.00	A	DT Assembly
DT	5.01	EX	DT Exploded
DT	5.10	PT	Motor Part
DT	5.20	PT	3" Pulley
DT	5.30	PT	Key
DT	5.40	PT	Base Mount
DT	5.50	PT	Fastener 1
DT	5.60	PT	Fastener 2
DTH	6.00	A	Drivetrain Housing Assembly
DTH	6.01	EX	Drivetrain Housing Exploded View
DTH	6.10	A	Drivetrain Housing Upper Assembly
DTH	6.11	EX	Drivetrain Housing Upper Exploded View
DTH	6.12	PT	Drivetrain Housing Upper Acrylic Plate 1
DTH	6.13	PT	Drivetrain Housing Upper Acrylic Plate 2
DTH	6.14	PT	Drivetrain Housing Upper Acrylic Plate 3

DTH	6.15	PT	Drivetrain Housing Upper Acrylic Plate 4
DTH	6.16	PT	Drivetrain Housing Upper Acrylic Plate 5
DTH	6.17	PT	Drivetrain Housing Upper Acrylic Plate 6
DTH	6.18	PT	Drivetrain Housing Upper Acrylic Plate 7
DTH	6.19	PT	Drivetrain Housing Upper Acrylic Plate 8
DTH	6.20	A	Drivetrain Lower Assembly
DTH	6.21	EX	Drivetrain Housing Lower Exploded View
DTH	6.22	PT	Drivetrain Housing Lower Acrylic Plate 1
DTH	6.23	PT	Drivetrain Housing Lower Acrylic Plate 2
DTH	6.24	PT	Drivetrain Housing Lower Acrylic Plate 3
DTH	6.25	PT	Drivetrain Housing Lower Acrylic Plate 4
DTH	6.26	PT	Drivetrain Housing Lower Acrylic Plate 5
DTH	6.27	PT	Drivetrain Housing Lower Acrylic Plate 6
DTH	6.28	PT	Drivetrain Housing Lower Acrylic Plate 7
DTH	6.29	PT	Drivetrain Housing Lower Acrylic Plate 8
DTH	6.30	PT	Conveyor Brush
DTH	6.40	PT	L Brackets
DTH	6.50	PT	Fasteners to Ground
HA	7.01	EX	Mill Table
EE			Motor Electrical
EE			Motor Specifications

4

3

2

1

ITEM NO.	PART NUMBER	DESCRIPTION	Default/ QTY.
1	M 1.10 PT	BASE PLATE	1
2	S 2.00 A	SUPPORT ASSEMBLY	1
3	S 3.00 A	PACMAN ASSEMBLY	2
4	PMH 4.00 A	PACMAN HOUSING ASSEMBLY	1
5	DT 5.00 A	DRIVETRAIN ASSEMBLY	1
6	PMH 6.00 A	PACMAN HOUSING ASSEMBLY	1

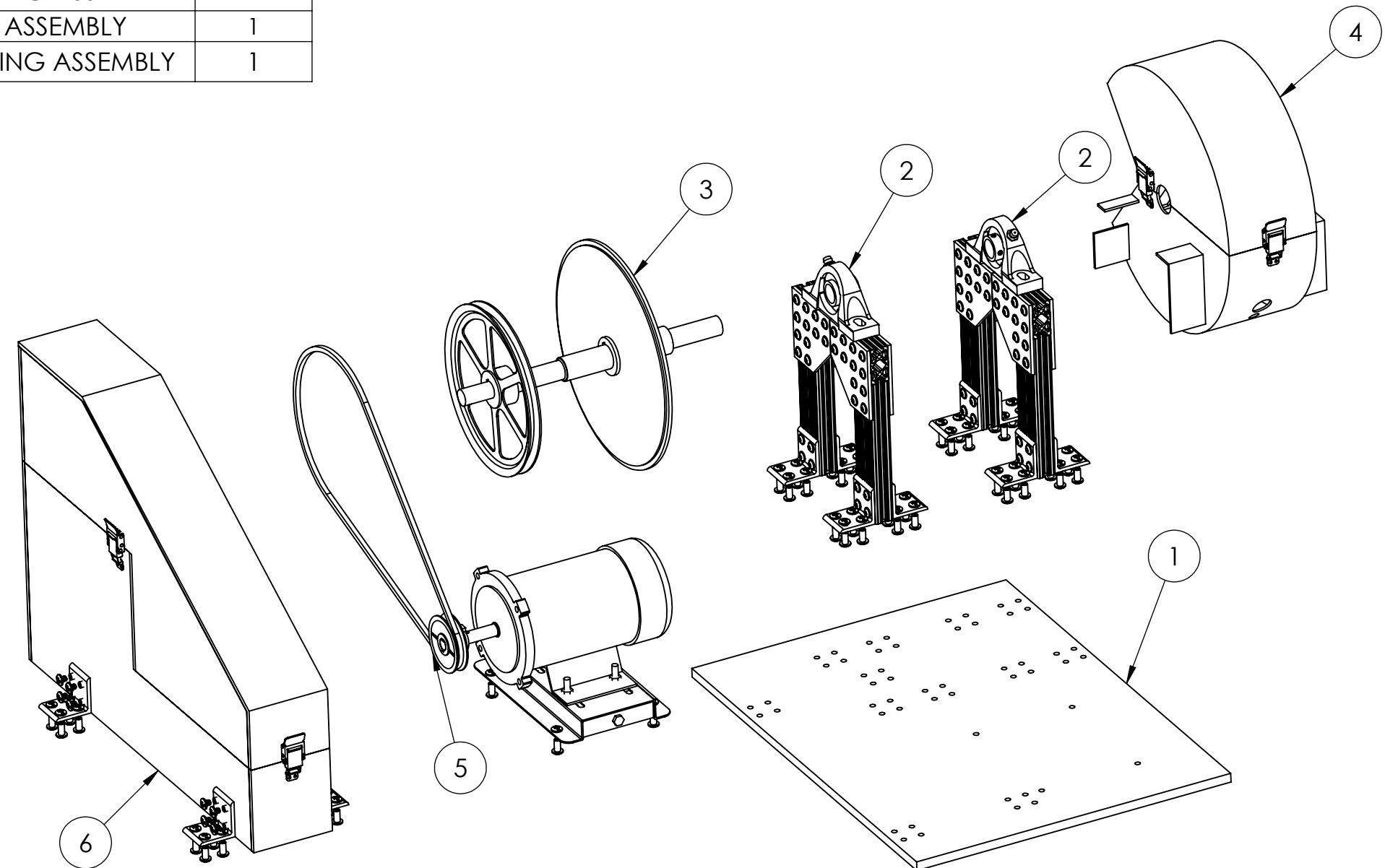

UNLESS OTHERWISE SPECIFIED:		NAME	DATE
DIMENSIONS ARE IN INCHES		DRAWN	SW 05/02/2018
TOLERANCES:		CHECKED	
X.XX = ± 0.01		ENG APPR.	
X.XXX = ± 0.001		MFG APPR.	
INTERPRET GEOMETRIC TOLERANCING PER:		Q.A.	
MATERIAL		COMMENTS:	
FINISH			
DO NOT SCALE DRAWING			
TITLE: <b>MACHINE EXPLODED</b>			
SIZE	DWG. NO.	REV	
<b>B</b>	<b>M 1.01 EX</b>	<b>1</b>	
SCALE: 1:7		WEIGHT:	SHEET 1 OF 1

3

2

1





4

3

2

1

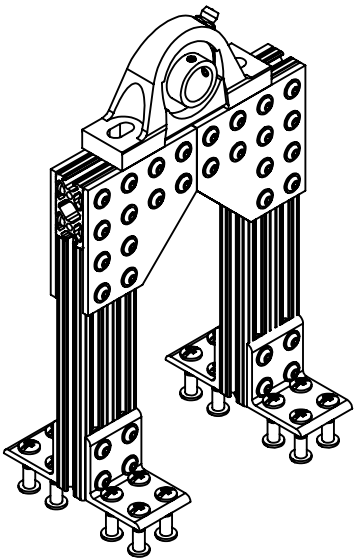
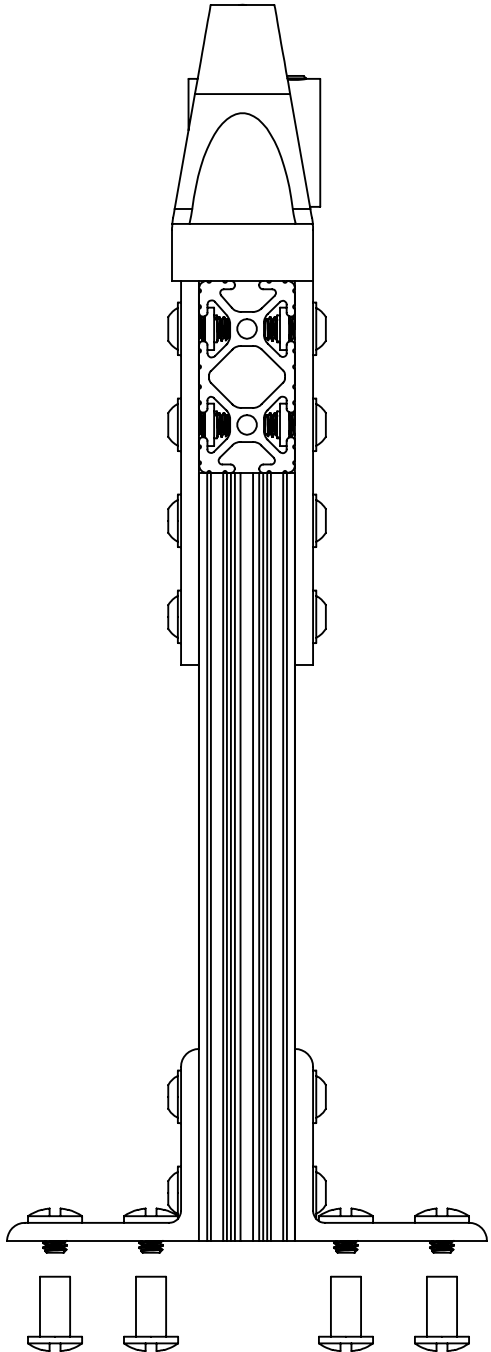
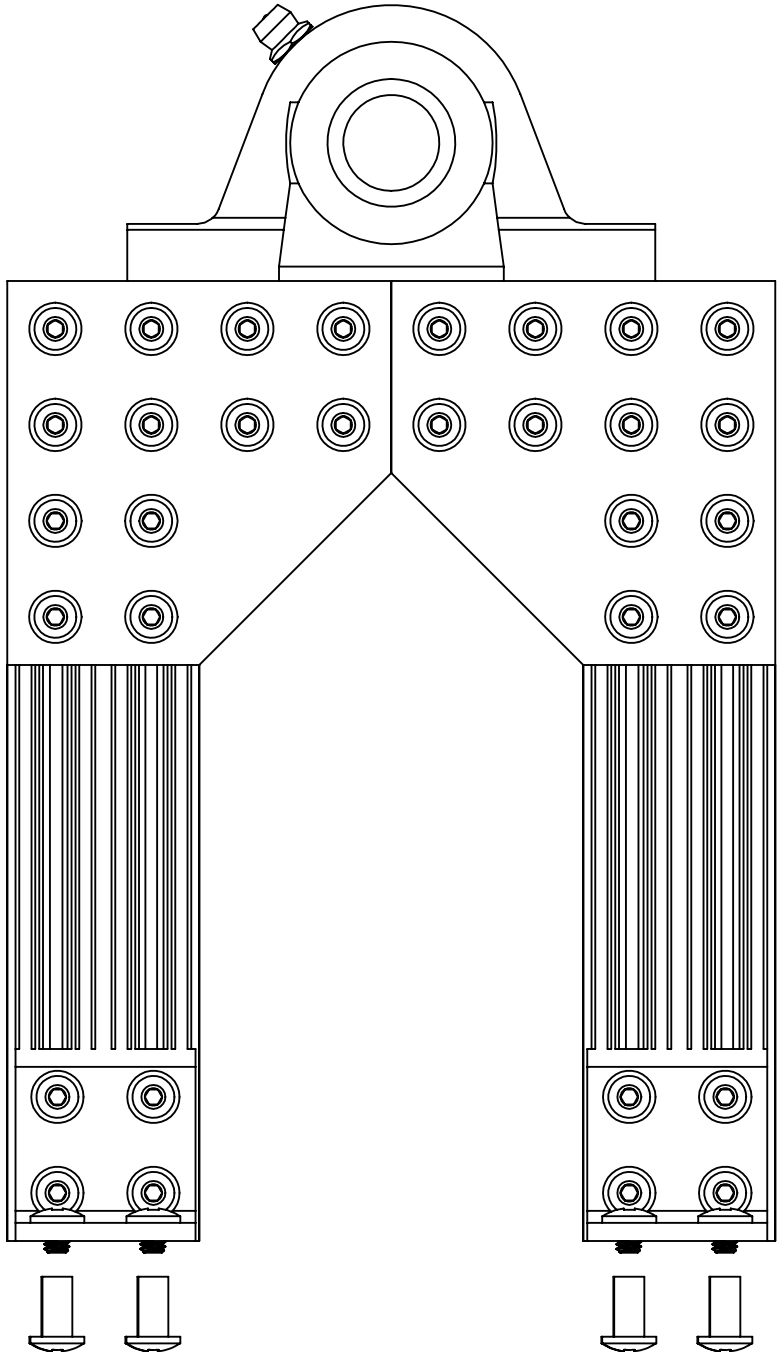

B

B

A

A

		UNLESS OTHERWISE SPECIFIED:		NAME	DATE
		DIMENSIONS ARE IN INCHES		DRAWN	SW 05/02/2018
		TOLERANCES:		CHECKED	
		TWO PLACE DECIMAL ± 0.01		ENG APPR.	
		THREE PLACE DECIMAL ± 0.001		MFG APPR.	
		INTERPRET GEOMETRIC TOLERANCING PER:		Q.A.	
		MATERIAL		COMMENTS:	
NEXT ASSY	USED ON	FINISH		<b>SUPPORT ASSEMBLY</b> TITLE: SIZE <b>B</b> DWG. NO. <b>S 2.00 A</b> REV <b>1</b> SCALE: 1:2 WEIGHT: SHEET 1 OF 1	
APPLICATION		DO NOT SCALE DRAWING			

4

3

2

1

4

3

2

1

ITEM NO.	PART NUMBER	DESCRIPTION	Default/ QTY.
1	S 2.10 PT	T-SLOTTED AL EXTRUSION	3
2	S 2.20 PT	TIMKEN PILLOW BLOCK BEARING	1
3	S 2.30 PT	L-BRACKETS	4
4	S 2.40 PT	CORNER SURFACE BRACKET	4
5	S 2.60 PT	RAIL FASTENERS	64
6	S 2.70 PT	BASE FASTENERS	16

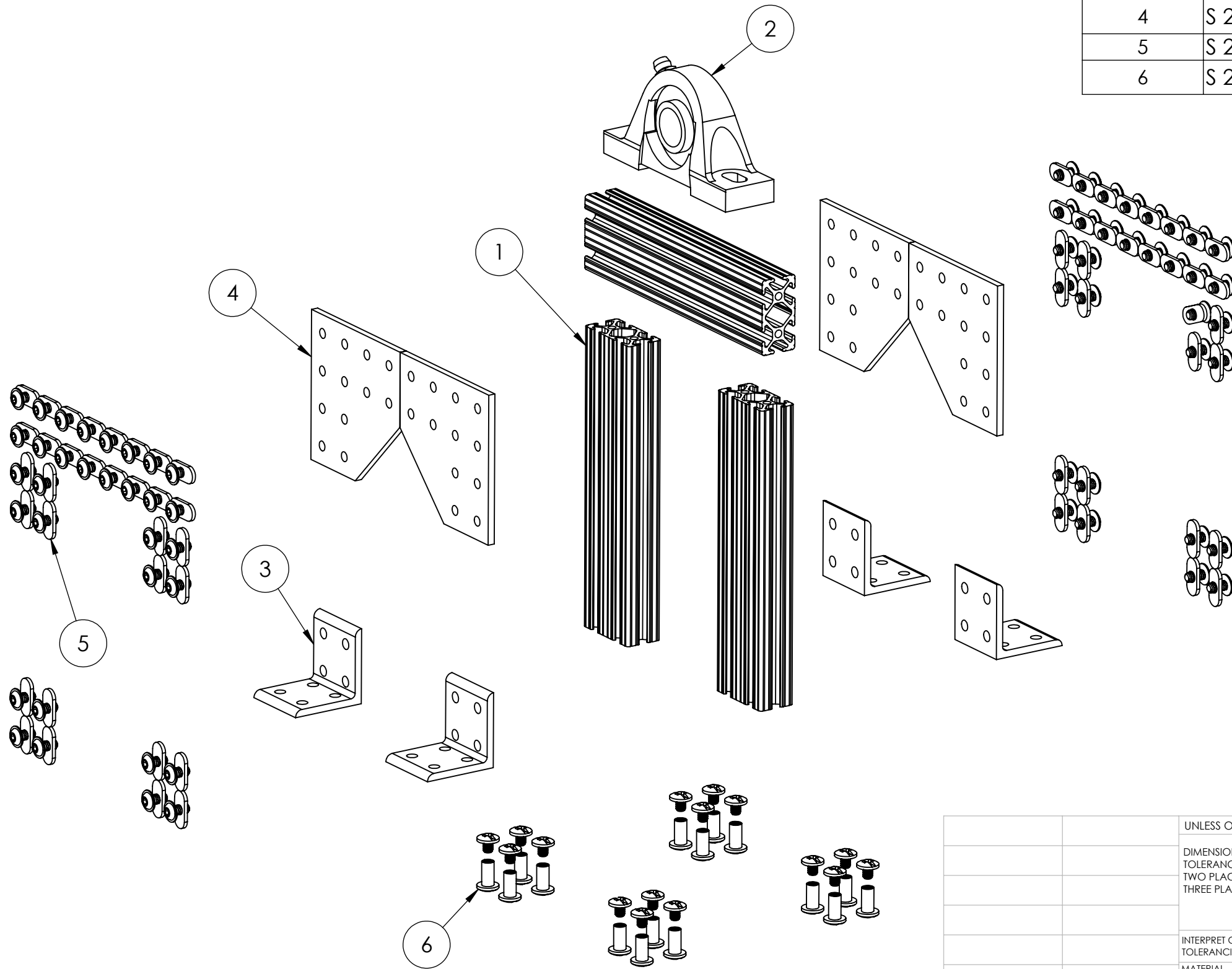

		UNLESS OTHERWISE SPECIFIED:		NAME	DATE
		DIMENSIONS ARE IN INCHES		DRAWN	SW 05/02/2018
		TOLERANCES:		CHECKED	
		TWO PLACE DECIMAL ± 0.01		ENG APPR.	
		THREE PLACE DECIMAL ± 0.001		MFG APPR.	
		INTERPRET GEOMETRIC TOLERANCING PER:		Q.A.	
		MATERIAL		COMMENTS:	
NEXT ASSY	USED ON	FINISH		<b>SUPPORT EXPLODED</b> SIZE DWG. NO. REV <b>B S 2.01 EX 1</b>	
APPLICATION		DO NOT SCALE DRAWING			
				SHEET 1 OF 1	

3

2

1

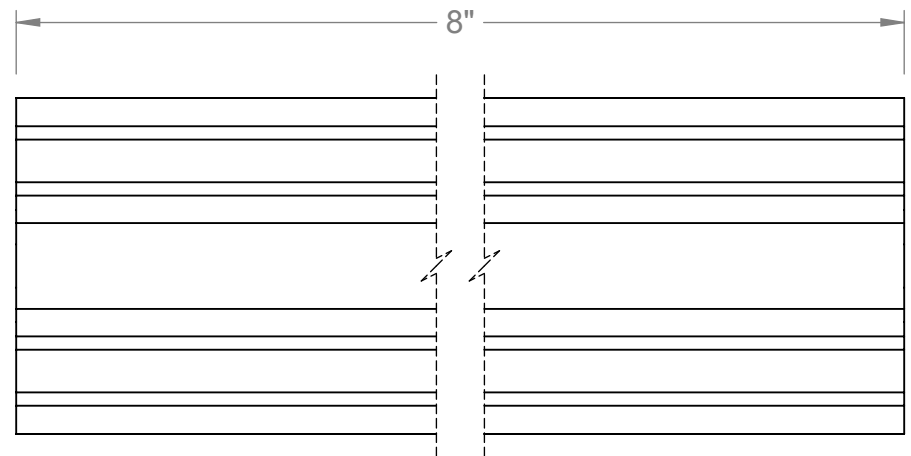
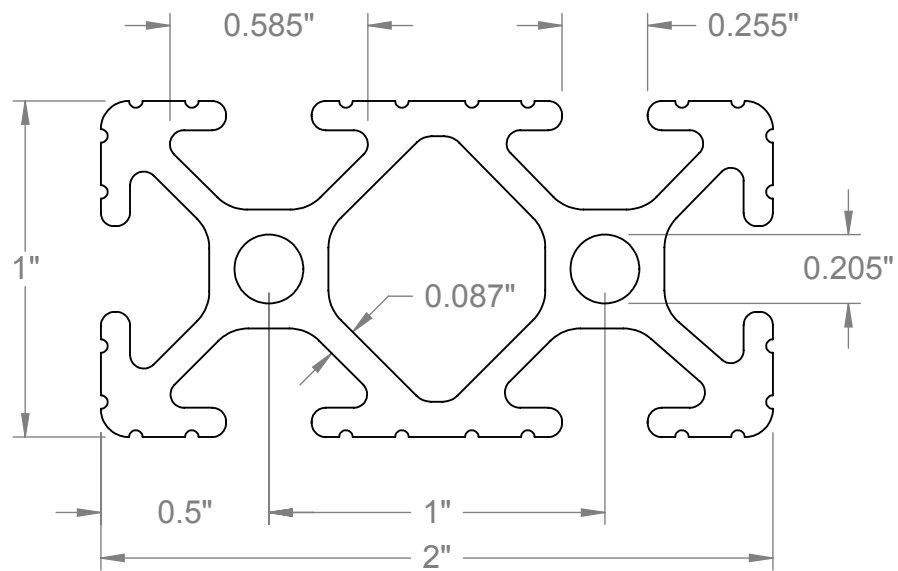
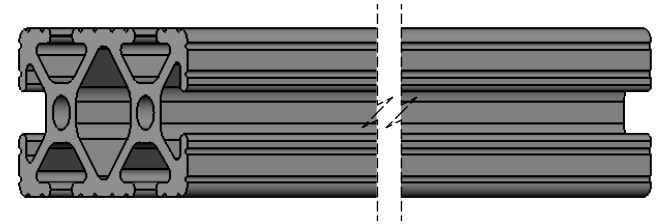

<b>McMASTER-CARR</b> <small>CAD</small> <a href="http://www.mcmaster.com">http://www.mcmaster.com</a> © 2015 McMaster-Carr Supply Company Information in this drawing is provided for reference only.	PART NUMBER	<b>S 2.10 PT</b>
	Aluminum T-Slotted Framing	

5/16"-18 x 3/8" Long  
Set Screw

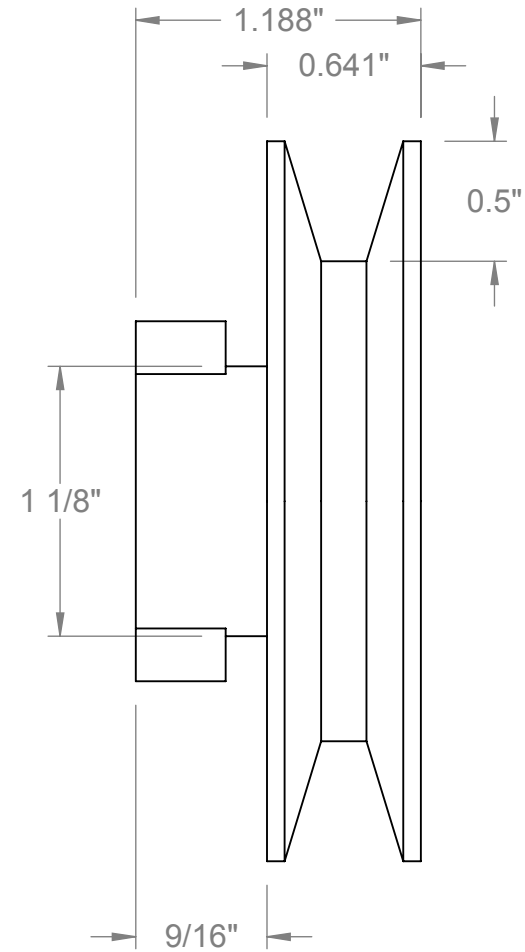
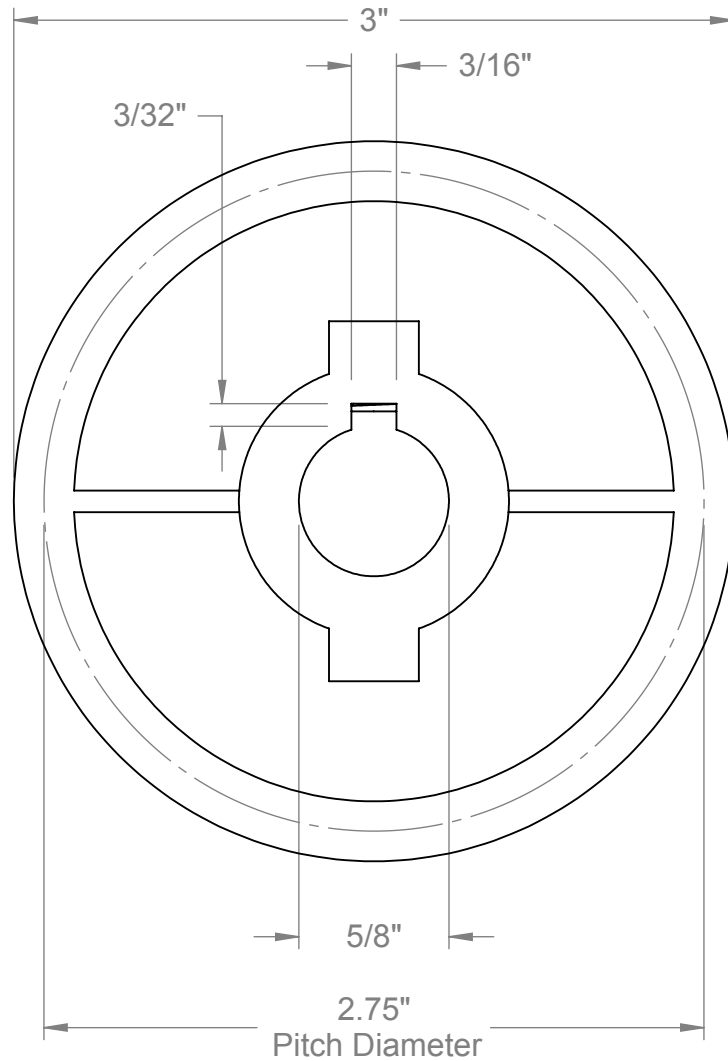
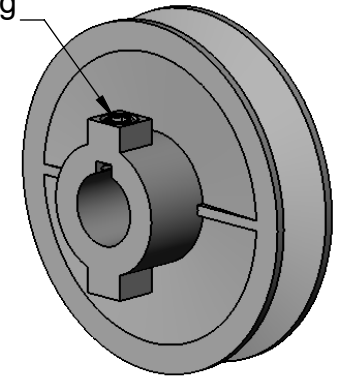

For V-Belt: A-Section (4L and A)

**McMASTER-CARR** CAD

PART  
NUMBER

**DT 5.20 PT**

<http://www.mcmaster.com>  
© 2014 McMaster-Carr Supply Company

V-Belt  
Pulley

Information in this drawing is provided for reference only.

ITEM NO.	PART NUMBER	DESCRIPTION	QTY.
1	PM 3.10 PT	SHAFT	1
2	PM 3.20 PT	DISK	1
3	PM 3.40 PT	9" PULLEY	1

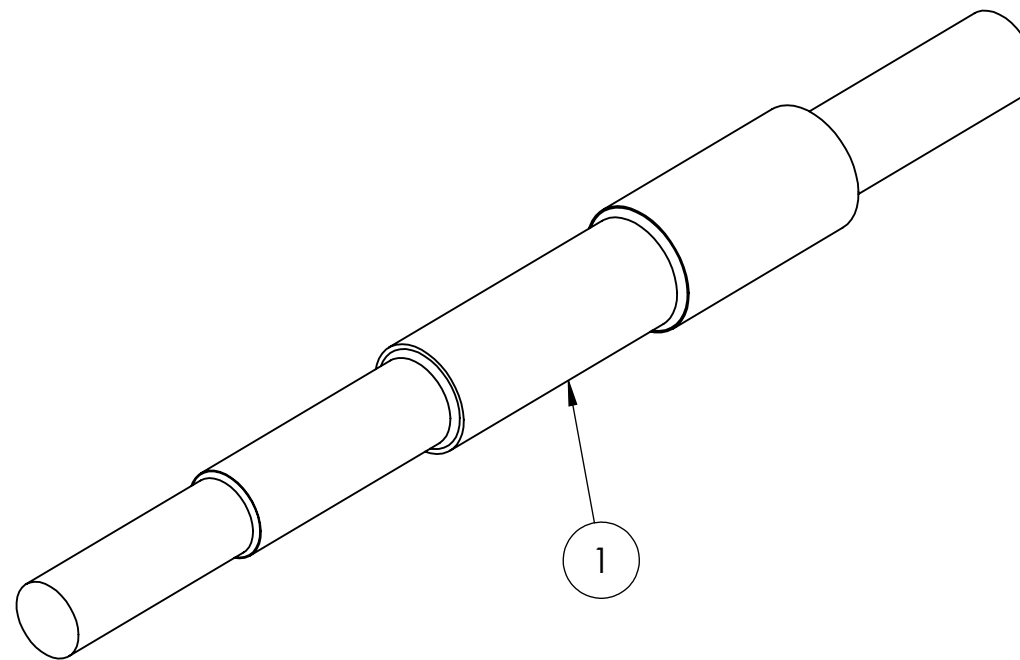
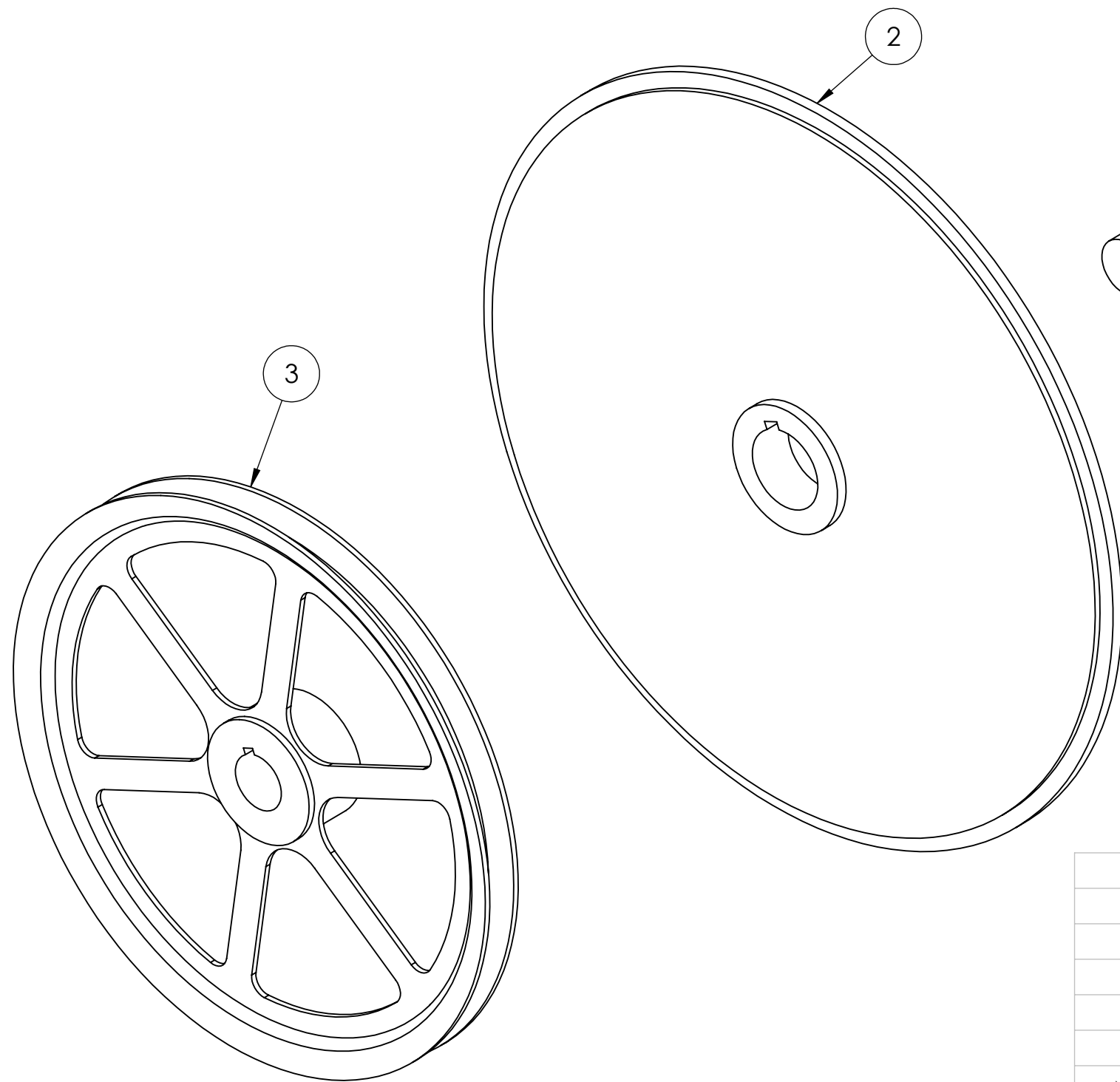

		UNLESS OTHERWISE SPECIFIED:	NAME	DATE		
		DIMENSIONS ARE IN INCHES	DRAWN	SW	05/02/2018	TITLE: <b>PACMAN EXPLODED</b>
		TOLERANCES:	CHECKED			
		INTERPRET GEOMETRIC TOLERANCING PER:	ENG APPR.			
		MATERIAL	MFG APPR.			
		FINISH	Q.A.			SIZE DWG. NO. REV <b>B PM 3.01 EX 1</b>
NEXT ASSY	USED ON	DO NOT SCALE DRAWING	COMMENTS:			
APPLICATION					SCALE: 1:2	WEIGHT:
						SHEET 1 OF 1

4

3

2

1

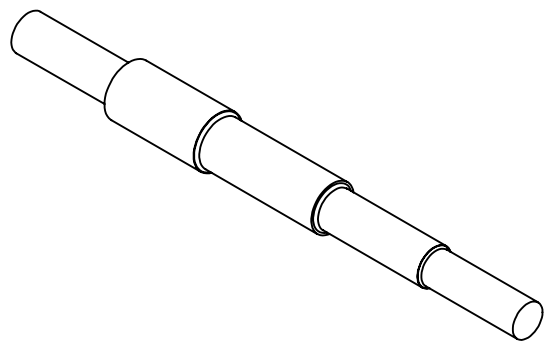

B

B

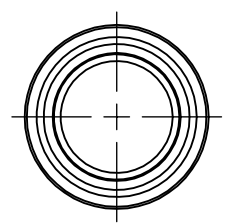
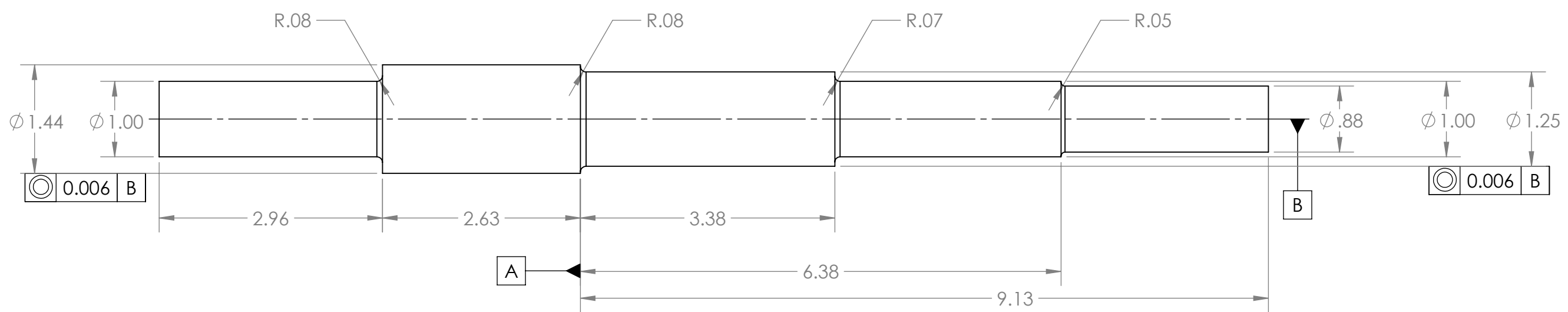

A

A

UNLESS OTHERWISE SPECIFIED:		NAME	DATE		
DIMENSIONS ARE IN INCHES		DRAWN	SW	05/02/2018	
TOLERANCES:		CHECKED			TITLE:
X.XX = ± 0.01		ENG APPR.			<b>SHAFT</b>
X.XXX = ±0.001		MFG APPR.			
INTERPRET GEOMETRIC TOLERANCING PER:		Q.A.			SIZE
MATERIAL		COMMENTS:			DWG. NO.
FINISH					REV
DO NOT SCALE DRAWING					<b>B</b>
					<b>PM 3.10 PT</b>
					<b>1</b>
					SCALE: 2:3
					WEIGHT:
					SHEET 1 OF 1

3  $\text{0.01}$

2

1

4

3

2

1

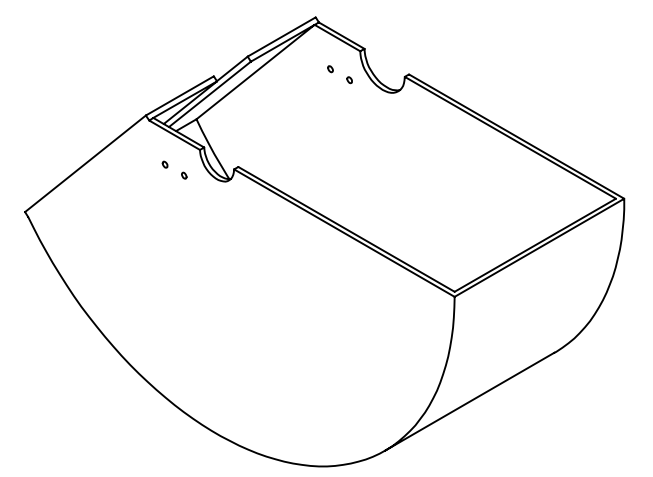
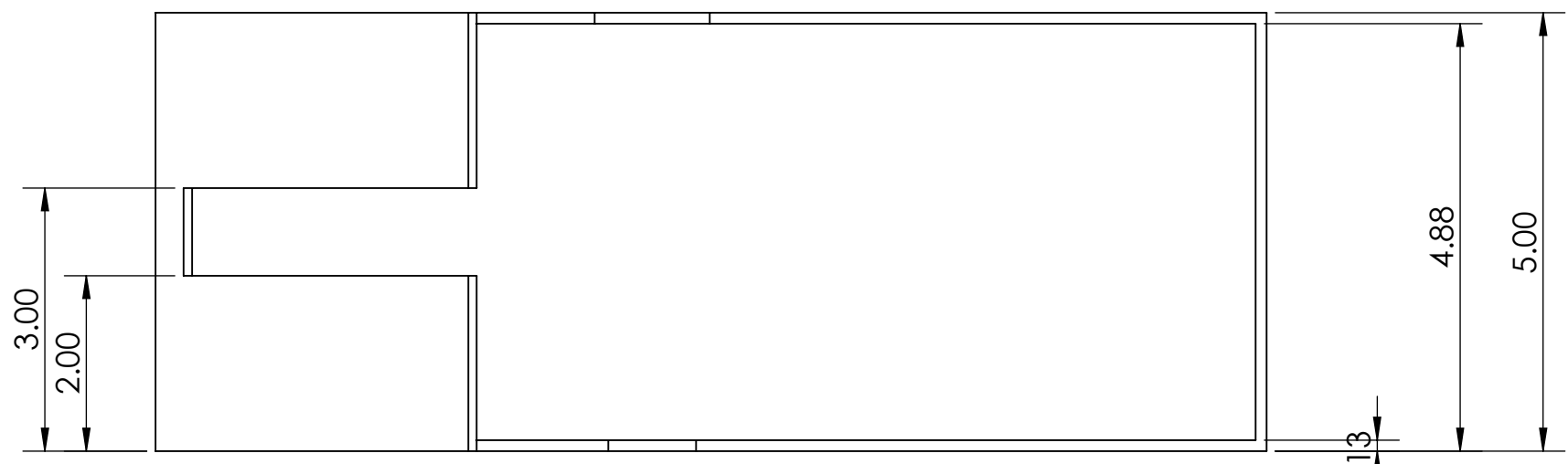

ISOMETRIC VIEW  
(For Reference Only)

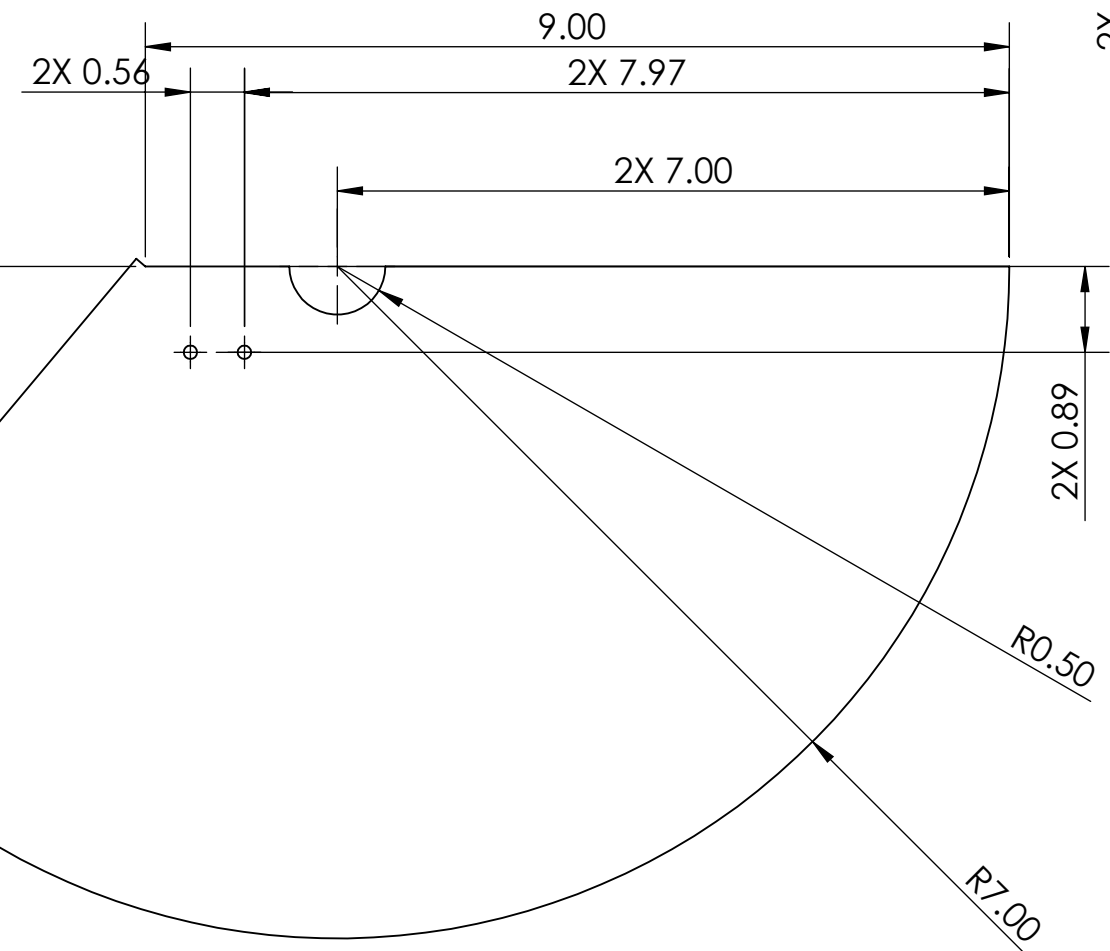

B

B

A

A

NOTE:

1. MATERIAL: 1/4" AISI 304 SHEET UNLESS OTHERWISE NOTED.
2. ALL FILLETS R.10 UNLESS OTHERWISE NOTED.
3. TOLERANCE: ±.01 INCH
4. GRIND U-SHAPE PORTION TO PARALLEL WITH TOP OF CASING.

		UNLESS OTHERWISE SPECIFIED:		NAME	DATE
		DIMENSIONS ARE IN INCHES		DRAWN	MC 05/03/2018
		TOLERANCES:		CHECKED	
		FRACTIONAL ±		ENG APPR.	
		ANGULAR: MACH ± BEND ±		MFG APPR.	
		TWO PLACE DECIMAL ±		Q.A.	
		THREE PLACE DECIMAL ±		COMMENTS:	
		INTERPRET GEOMETRIC TOLERANCING PER:			
		MATERIAL			
		FINISH			
NEXT ASSY	USED ON				
APPLICATION		DO NOT SCALE DRAWING			
TITLE:			PACMAN HOUSING UPPER		
SIZE	DWG. NO.	REV			
<b>B</b>	PMH 1.10 A	1			
SCALE: 1:2		WEIGHT:	SHEET 1 OF 1		

4

3

2

1



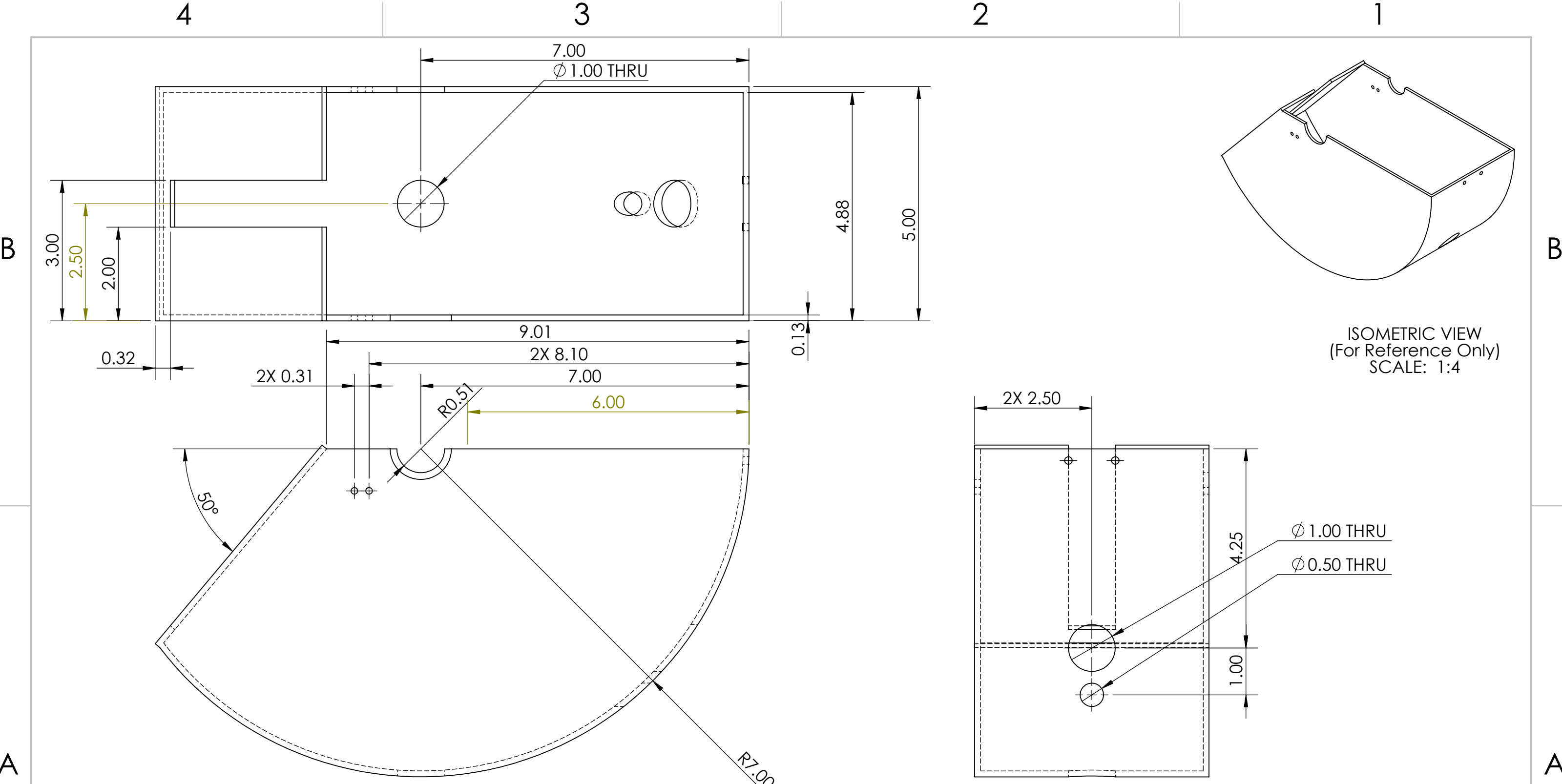

NOTE:

1. MATERIAL: 1/4" AISI 304 SHEET UNLESS OTHERWISE NOTED
2. ALL FILLETS R.10 UNLESS OTHERWISE NOTED
3. TOLERANCE: ±.01 INCH
4. GRIND U-SHAPE PORTION TO PARALLEL WITH TOP OF CASING.

**PROPRIETARY AND CONFIDENTIAL**  
 THE INFORMATION CONTAINED IN THIS DRAWING IS THE SOLE PROPERTY OF <INSERT COMPANY NAME HERE>. ANY REPRODUCTION IN PART OR AS A WHOLE WITHOUT THE WRITTEN PERMISSION OF <INSERT COMPANY NAME HERE> IS PROHIBITED.

		UNLESS OTHERWISE SPECIFIED:		NAME	DATE
		DIMENSIONS ARE IN INCHES		DRAWN	MC 05/02/2018
		TOLERANCES:		CHECKED	
		TWO PLACE DECIMAL ± 0.01		ENG APPR.	
		THREE PLACE DECIMAL ± 0.001		MFG APPR.	
		INTERPRET GEOMETRIC TOLERANCING PER:		Q.A.	
		MATERIAL		COMMENTS:	
NEXT ASSY	USED ON	FINISH			
APPLICATION		DO NOT SCALE DRAWING			
TITLE: <b>PACMAN HOUSING LOW</b>					
SIZE	DWG. NO.	REV			
<b>B</b>	<b>PMH 4.20 A</b>	<b>1</b>			
SCALE: 1:2		WEIGHT:		SHEET 1 OF 2	

4

3

2

1

B

B

A

A

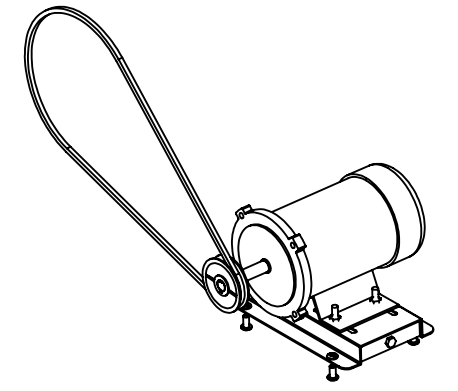
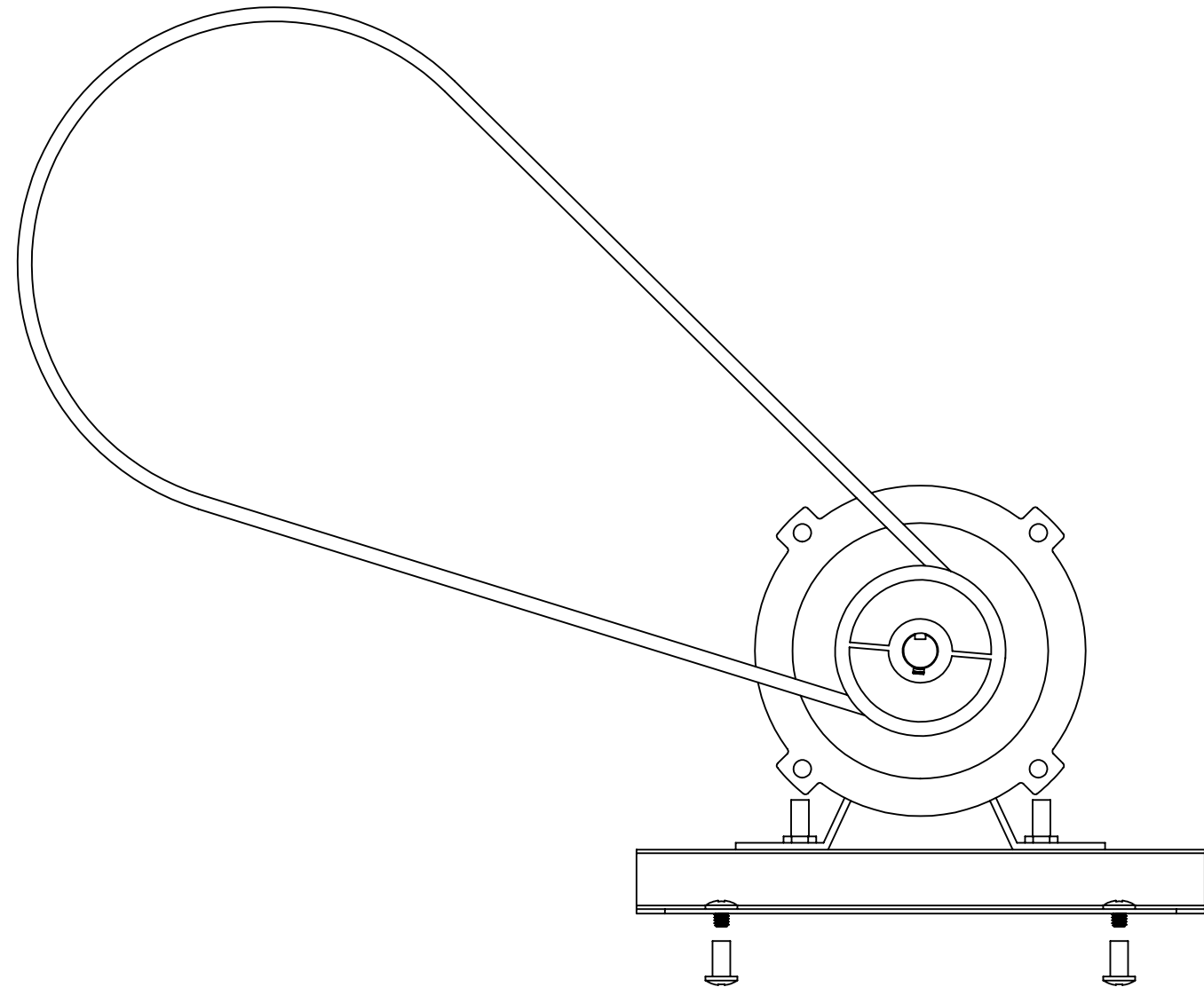
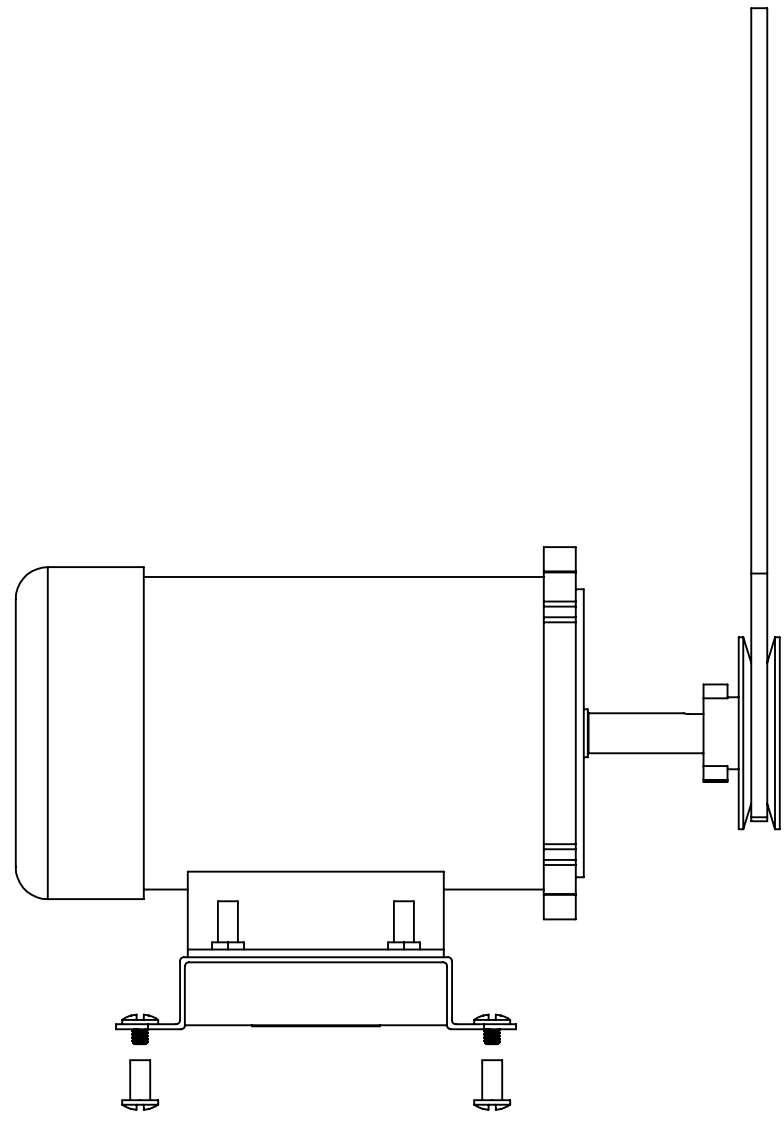

		UNLESS OTHERWISE SPECIFIED:		NAME	DATE
		DIMENSIONS ARE IN INCHES TOLERANCES:		DRAWN	SW 05/02/2018
		INTERPRET GEOMETRIC TOLERANCING PER:		CHECKED	
		MATERIAL		ENG APPR.	
		FINISH		MFG APPR.	
NEXT ASSY	USED ON			Q.A.	
APPLICATION		DO NOT SCALE DRAWING		COMMENTS:	
				TITLE:	
				DRIVETRAIN ASSEMBLY	
SIZE	DWG. NO.			REV	
<b>B</b>	DT 5.00 A			1	
SCALE: 1:3		WEIGHT:		SHEET 1 OF 1	

4

3

2

1

4

3

2

1

ITEM NO.	PART NUMBER	DESCRIPTION	QTY.
1	DT 5.10 PT	MOTOR	1
2	DT 5.20 PT	3" PULLEY	1
3	DT 5.40 PT	MOTOR BASE TENSIONER	1
4	S 2.70 PT	BASE FASTENER	4
5	-	V-BELT	1

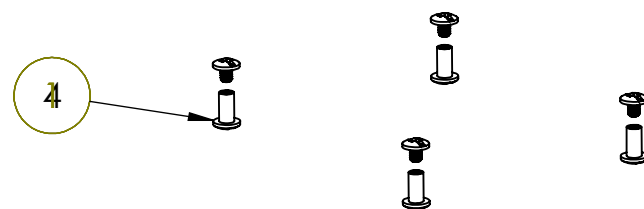
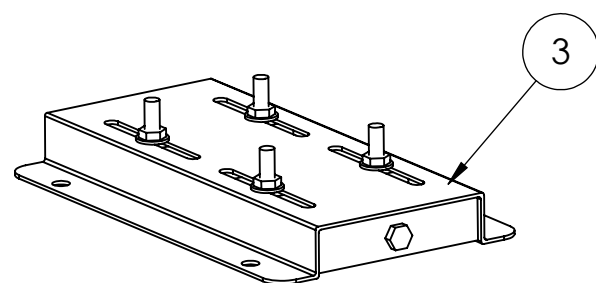
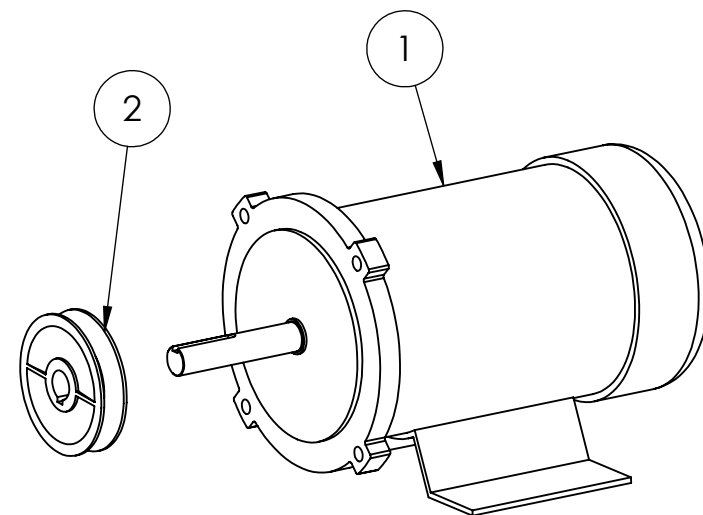
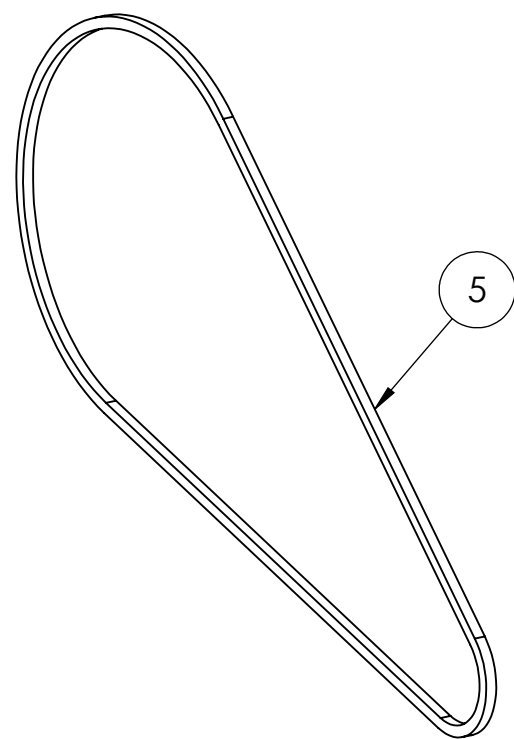

		UNLESS OTHERWISE SPECIFIED:	NAME	DATE	TITLE: <h1>DRIVETRAIN EXPLODED</h1>	
		DIMENSIONS ARE IN INCHES	DRAWN	SW		05/02/2018
		TOLERANCES:	CHECKED			
			ENG APPR.			
			MFG APPR.			
		INTERPRET GEOMETRIC TOLERANCING PER:	Q.A.			
		MATERIAL	COMMENTS:			
NEXT ASSY	USED ON	FINISH			SIZE DWG. NO. REV <b>B</b> DT 5.01 EX 1	
APPLICATION		DO NOT SCALE DRAWING		SCALE: 1:4	WEIGHT: SHEET 1 OF 1	

3

2

1

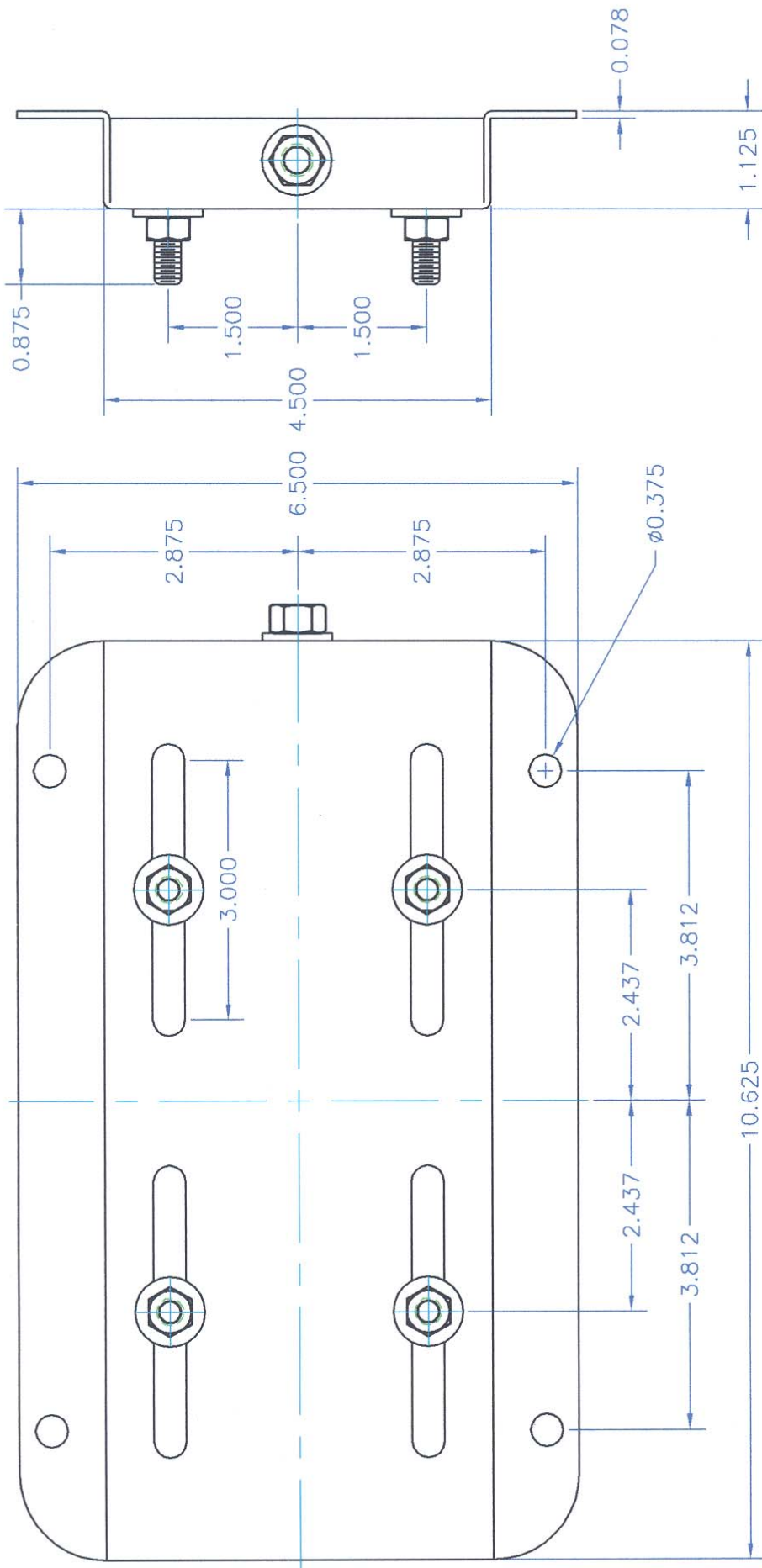

TOLERANCES (EXCEPT AS NOTED)		REVISIONS	
FORMAL	FRACTIONAL	NO.	DATE
±		1	
±		2	
±		3	
±		4	
±		5	

OVERLY HAUTZ MOTOR BASE COMPANY 215 SOUTH WEST STREET LEBANON, OHIO 45036		DESIGNED BY E.J.B.	
<b>56 MOTOR BASE</b>		CHECKED BY R. GORSUCH	
UNITS INCHES	N.T.S.	DATE 04/03/06	APPROVED BY E.J.B.
DT 5.40 PT			

THIS DRAWING IS THE PROPERTY OF THE OVERLY HAUTZ MOTOR BASE COMPANY OF LEBANON, OHIO AND IS LOANED SUBJECT TO THE CONDITION THAT IT IS NOT TO BE USED IN WHOLE OR IN PART TO ASSIST IN MAKING OR TO FURNISH ANY INFORMATION FOR THE MAKING OF ANY OTHER DRAWING OR PARTS THEREOF WITHOUT WRITTEN PERMISSION. THE LIABILITY OF THE OVERLY HAUTZ MOTOR BASE COMPANY AND ITS SUCCESSORS IS LIMITED TO THE WARRANTIES WHICH EXTEND BEYOND THE DESCRIPTION ON THE FACE HEREOF.

4

3

2

1

12.00

16.44

23.00

5.83

0.58

4.00

4.13

4.58

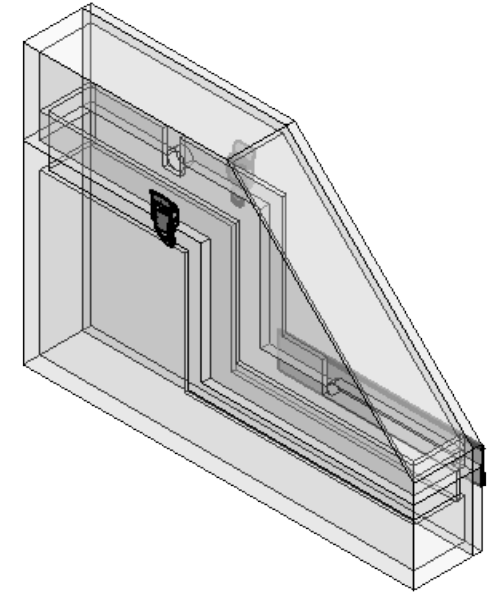

B

B

A

A

		UNLESS OTHERWISE SPECIFIED:		NAME	DATE
		DIMENSIONS ARE IN INCHES		DRAWN	SW 05/02/2018
		TOLERANCES:		CHECKED	
		TWO PLACE DECIMAL ± 0.01		ENG APPR.	
		THREE PLACE DECIMAL ± 0.001		MFG APPR.	
		INTERPRET GEOMETRIC TOLERANCING PER:		Q.A.	
		MATERIAL		COMMENTS:	
NEXT ASSY	USED ON	FINISH			
APPLICATION		DO NOT SCALE DRAWING			
				TITLE:	
				DT HOUSING ASSEMBLY	
SIZE	DWG. NO.	REV			
<b>B</b>	DTH 6.00 A	1			
SCALE: 1:20			WEIGHT:	SHEET 1 OF 1	

4

3

2

1

4

3

2

1

ITEM NO.	PART NUMBER	DESCRIPTION	QTY.
1	DTH 6.20 A	LOWER COVER	1
2	DTH 6.10 A	UPPER COVER	1
3	DTH 6.30 PT	CONVEYOR BRUSH	1
4	PMH 4.30 PT	DRAW LATCH	2

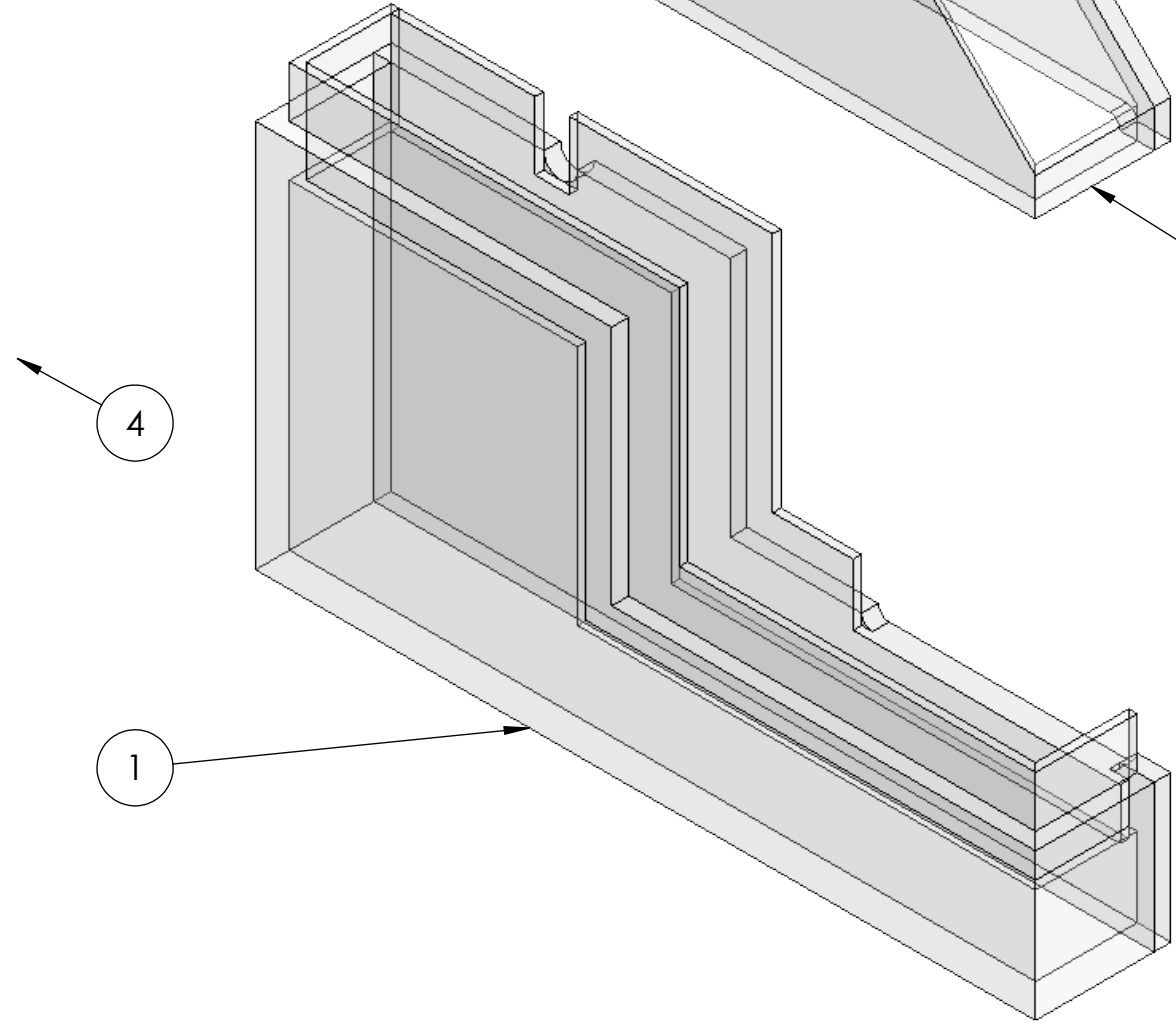
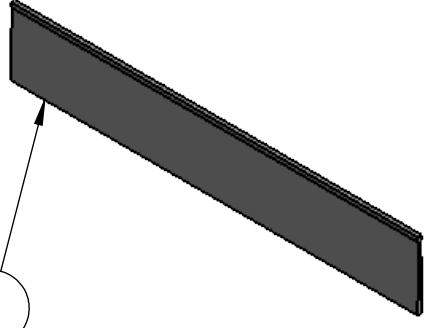
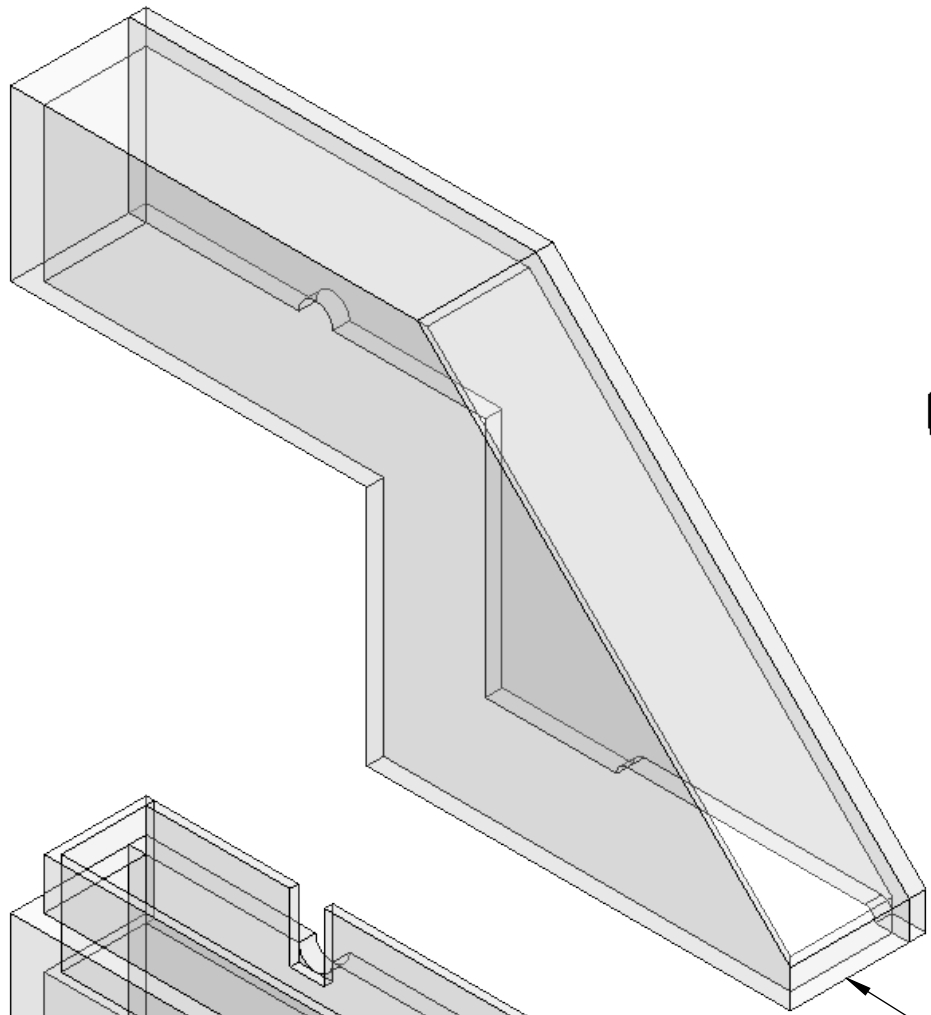

3

2

4

1

		UNLESS OTHERWISE SPECIFIED:	NAME	DATE	TITLE: <b>DT HOUSING EXPLODED</b>
		DIMENSIONS ARE IN INCHES TOLERANCES:	DRAWN	SW 05/02/2018	
			CHECKED		
			ENG APPR.		
			MFG APPR.		
		INTERPRET GEOMETRIC TOLERANCING PER:	Q.A.		SIZE DWG. NO. REV <b>B DTH 6.01 EX 1</b>
		MATERIAL	COMMENTS:		
NEXT ASSY	USED ON	FINISH			SCALE: 1:20 WEIGHT:
APPLICATION		DO NOT SCALE DRAWING		SHEET 1 OF 1	

4

3

2

1

4

3

2

1

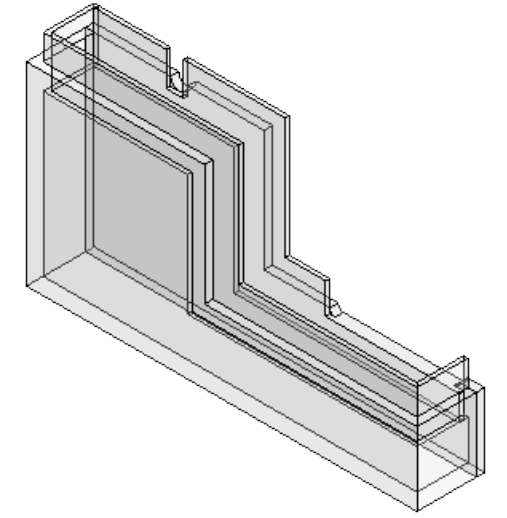

B

B

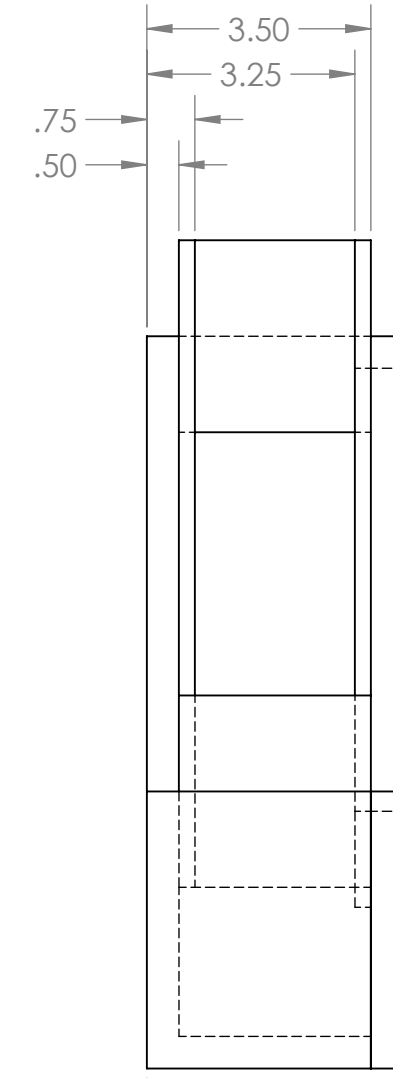
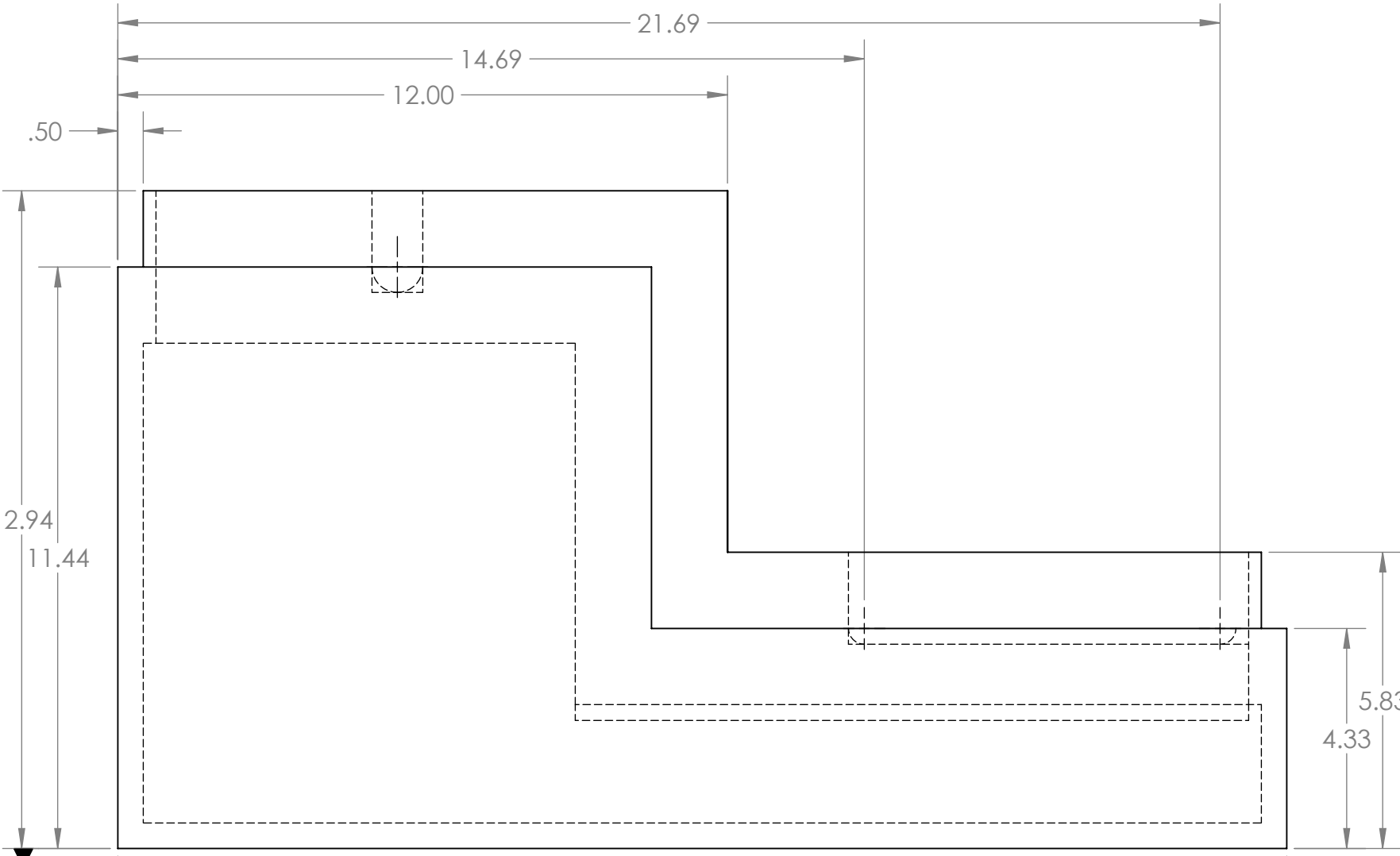

A

A

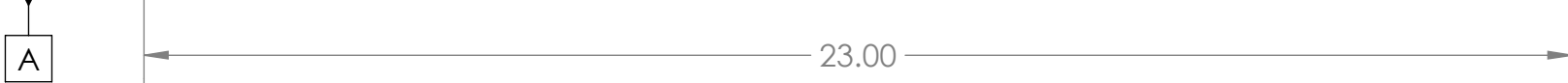

A

B

		UNLESS OTHERWISE SPECIFIED:		NAME	DATE
		DIMENSIONS ARE IN INCHES		DRAWN	SW 05/02/2018
		TOLERANCES:		CHECKED	
		TWO PLACE DECIMAL ± 0.01		ENG APPR.	
		THREE PLACE DECIMAL ± 0.001		MFG APPR.	
		INTERPRET GEOMETRIC TOLERANCING PER:		Q.A.	
		MATERIAL		COMMENTS:	
NEXT ASSY	USED ON	FINISH			
APPLICATION		DO NOT SCALE DRAWING			
				TITLE:	
				DT HOUSING LOWER	
SIZE	DWG. NO.	REV			
<b>B</b>	<b>DTH 6.20 A</b>	<b>1</b>			
SCALE: 1:5		WEIGHT:		SHEET 1 OF 1	

4

3

2

1

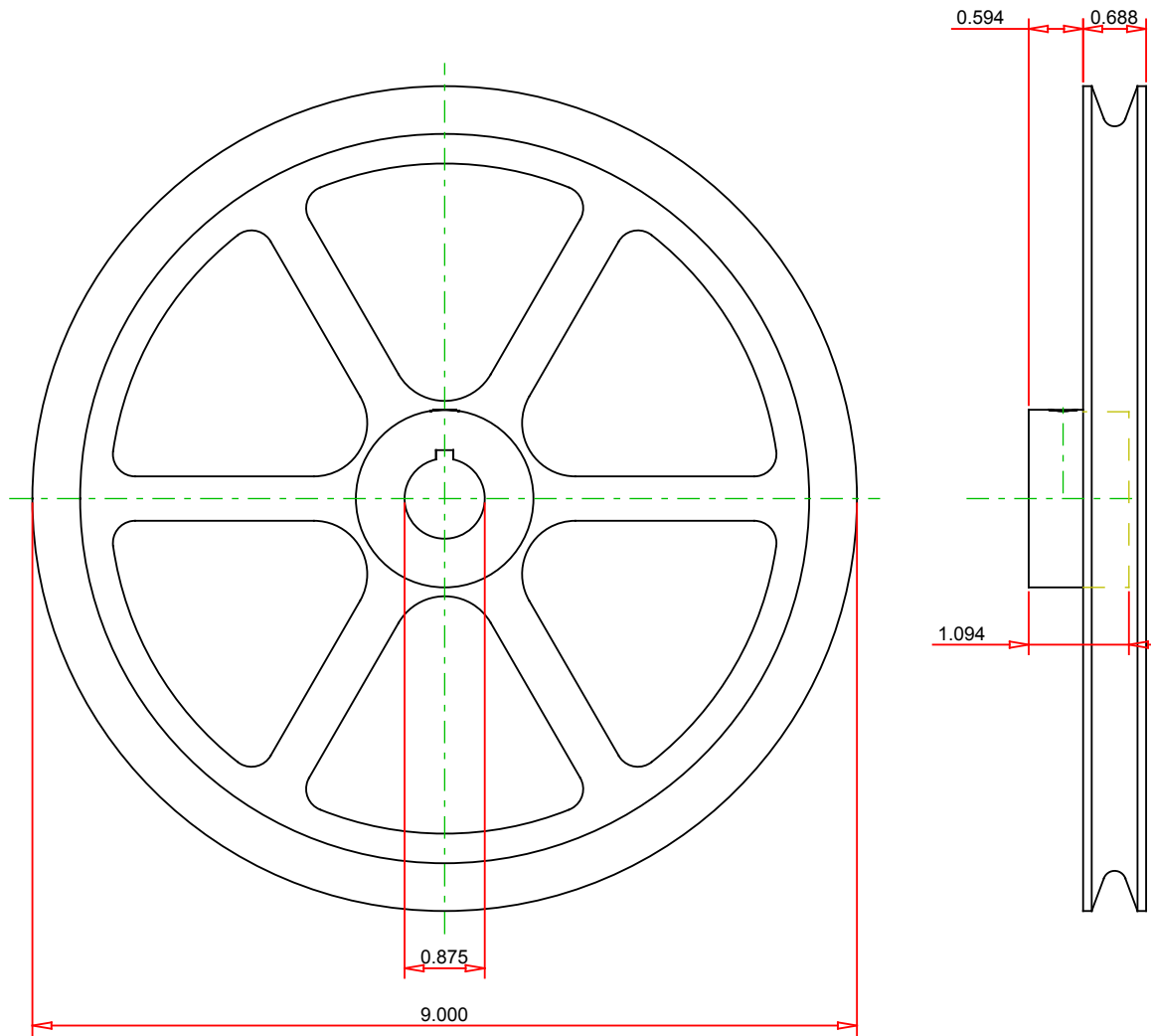

Screw : Hex Socket Set Screw, 5/16-18

Note : - Drawing not to Scale

Part No. :  
PM 3.40 PT

Material :  
Zamak-3 Zinc

Finish :  
Plain

Description :  
A Groove Pulleys

**Congress Drives**  
 Address : Congress Drives  
 2501 Brombeck Street  
 Ennis, TX 75119  
 Phone: 972-875-6060 Fax: 972-875-6160  
 Email : sales@congressdrives.com  
 Web : www.congressdrives.com

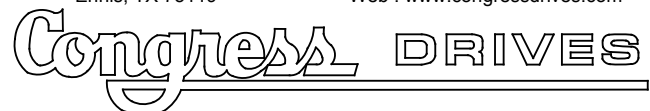



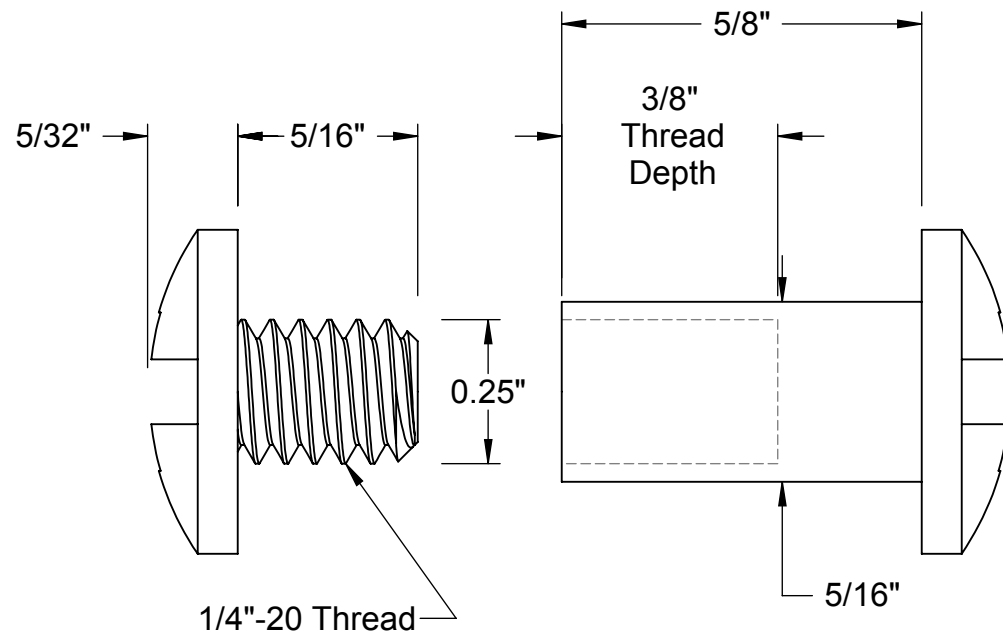
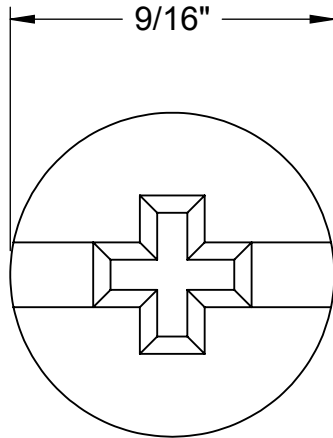
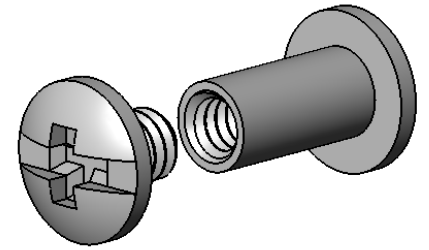

5/8"-3/4" Material Thickness

<b>McMASTER-CARR</b> <small>CAD</small> <a href="http://www.mcmaster.com">http://www.mcmaster.com</a> © 2013 McMaster-Carr Supply Company Information in this drawing is provided for reference only.	PART NUMBER <b>S 2.70 PT</b>
	Binding Post

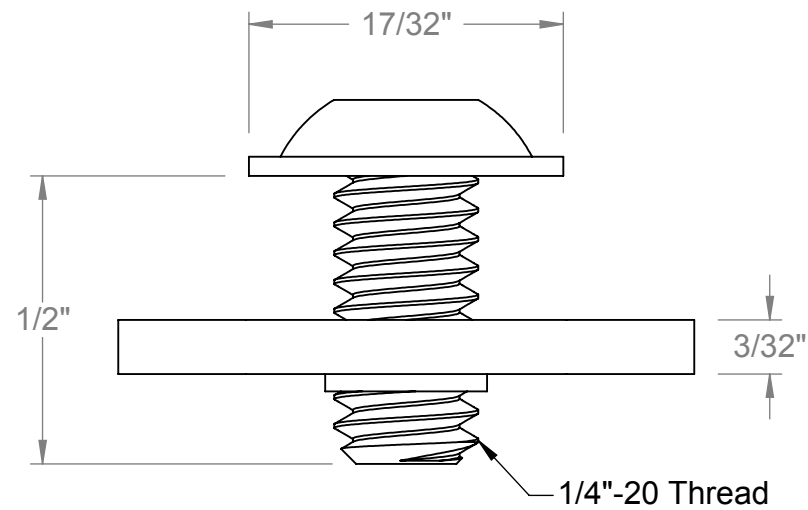
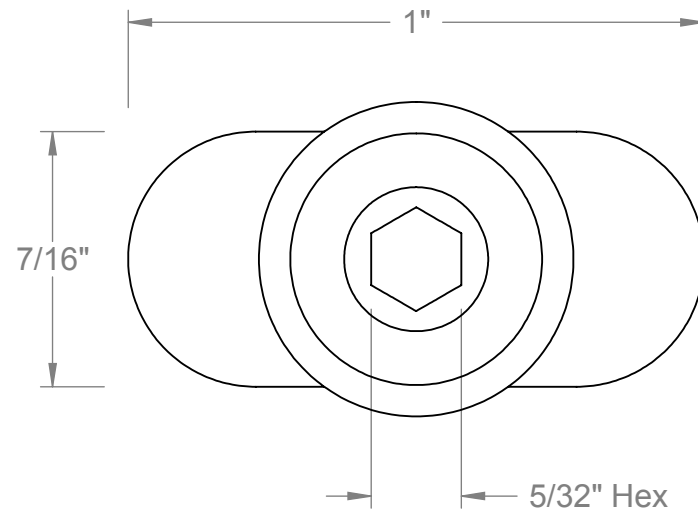
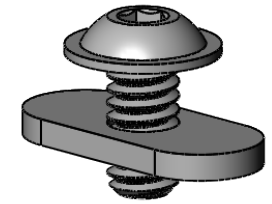

**McMASTER-CARR** CAD

PART  
NUMBER

**S 2.60 PT**

<http://www.mcmaster.com>  
© 2015 McMaster-Carr Supply Company

End-Feed Fastener for  
Aluminum T-Slotted Framing

Information in this drawing is provided for reference only.

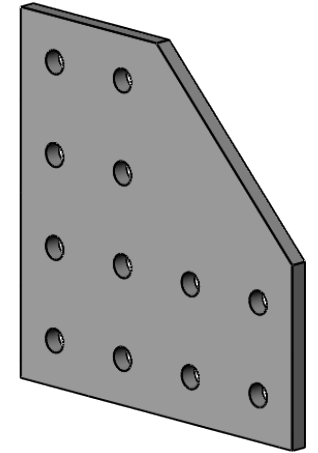
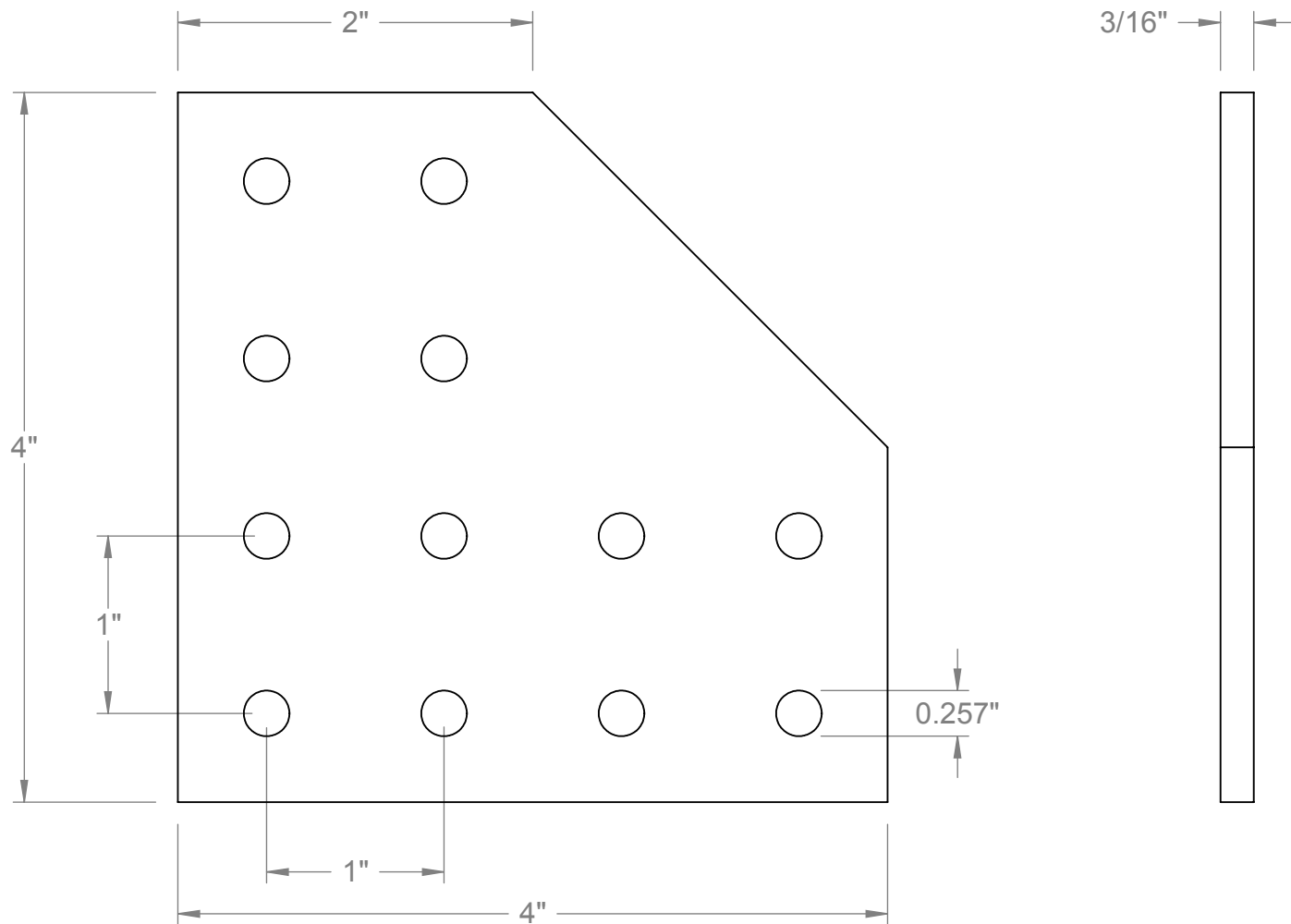

<b>McMASTER-CARR</b> <sup>CAD</sup> <a href="http://www.mcmaster.com">http://www.mcmaster.com</a> © 2015 McMaster-Carr Supply Company Information in this drawing is provided for reference only.	PART NUMBER	<b>S 2.40 PT</b>
	90° Plate for Aluminum T-Slotted Framing	

4

3

2

1

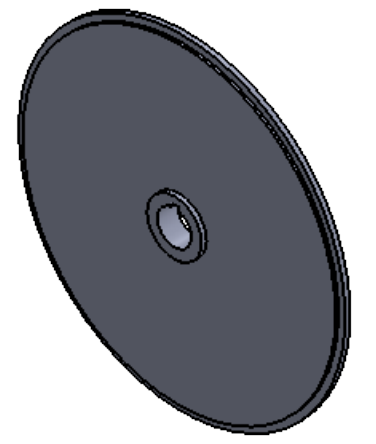
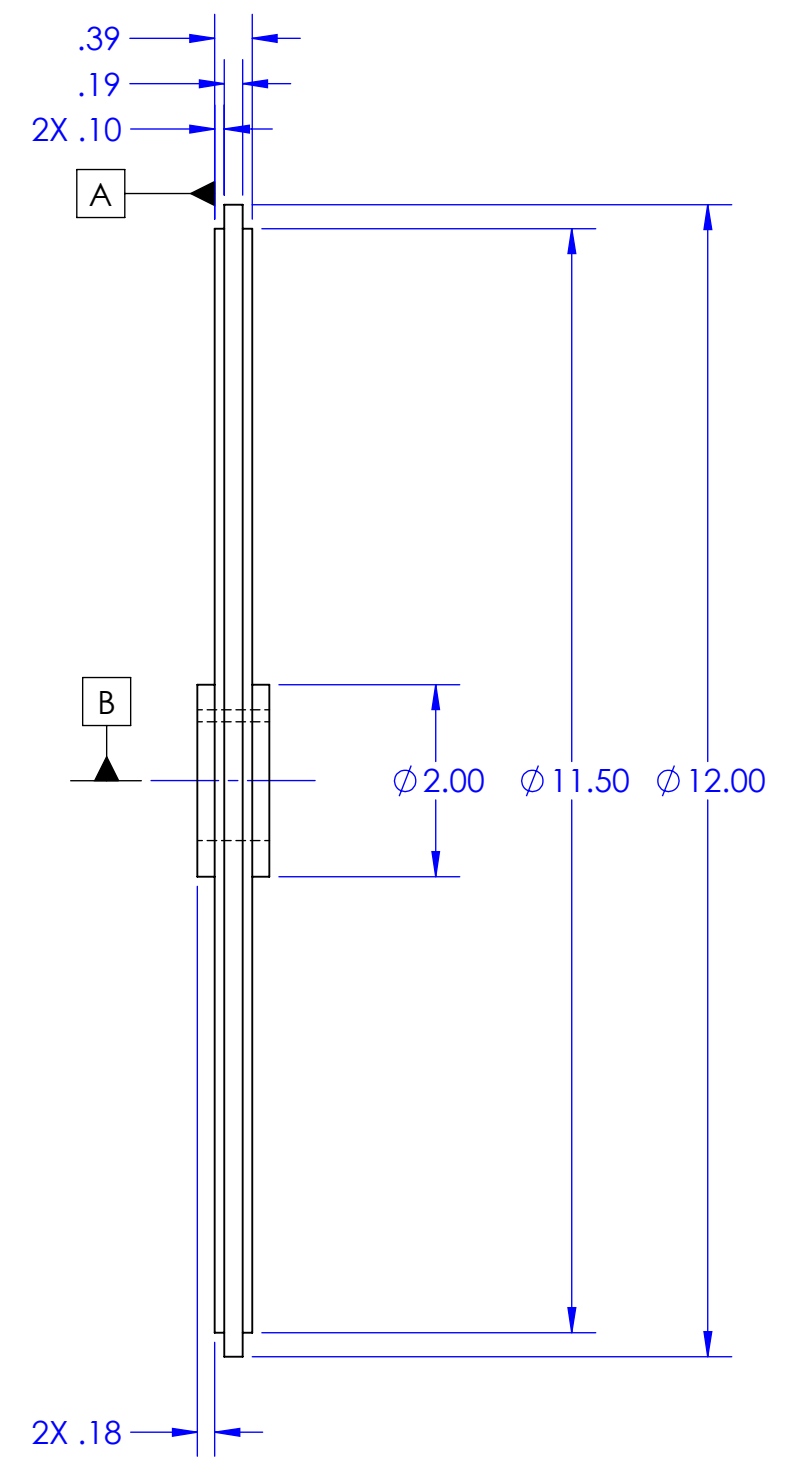
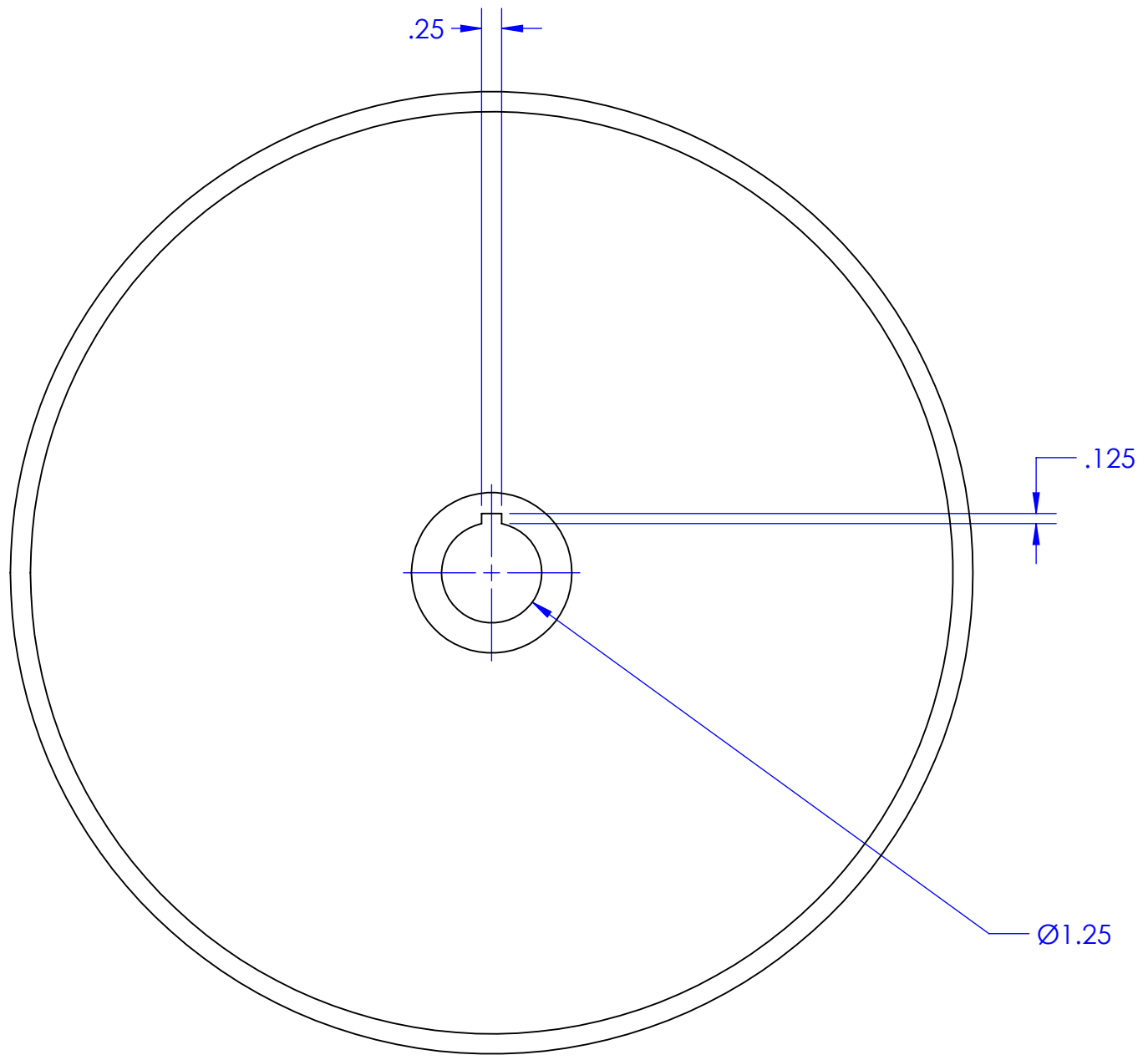

UNLESS OTHERWISE SPECIFIED:		NAME	DATE	TITLE: <b>DISK</b>	
DIMENSIONS ARE IN INCHES		DRAWN	SW		04/29/2018
TOLERANCES: X.XX = ±0.01 X.XXX = ±0.001		CHECKED			
		ENG APPR.			
		MFG APPR.			
MATERIAL AISI 304 SS		COMMENTS:		SIZE	
FINISH				DWG. NO.	
DO NOT SCALE DRAWING				<b>B PM 3.20 PT</b>	
				REV	
				<b>1</b>	
				SCALE: 1:2	
				WEIGHT:	
				SHEET 1 OF 1	

4

3

2

1

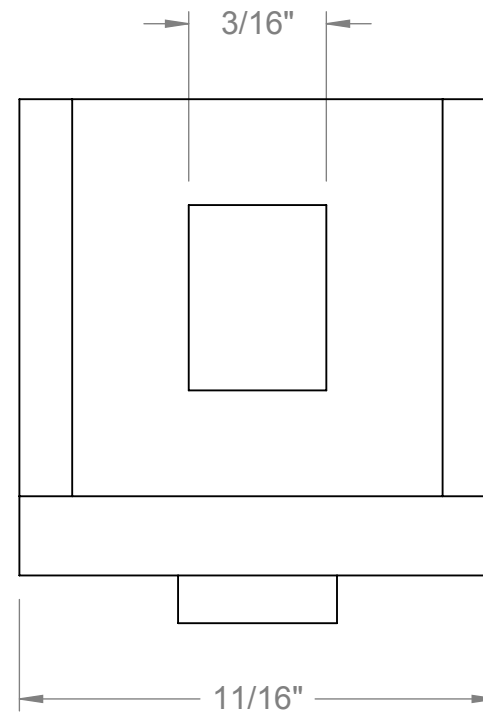
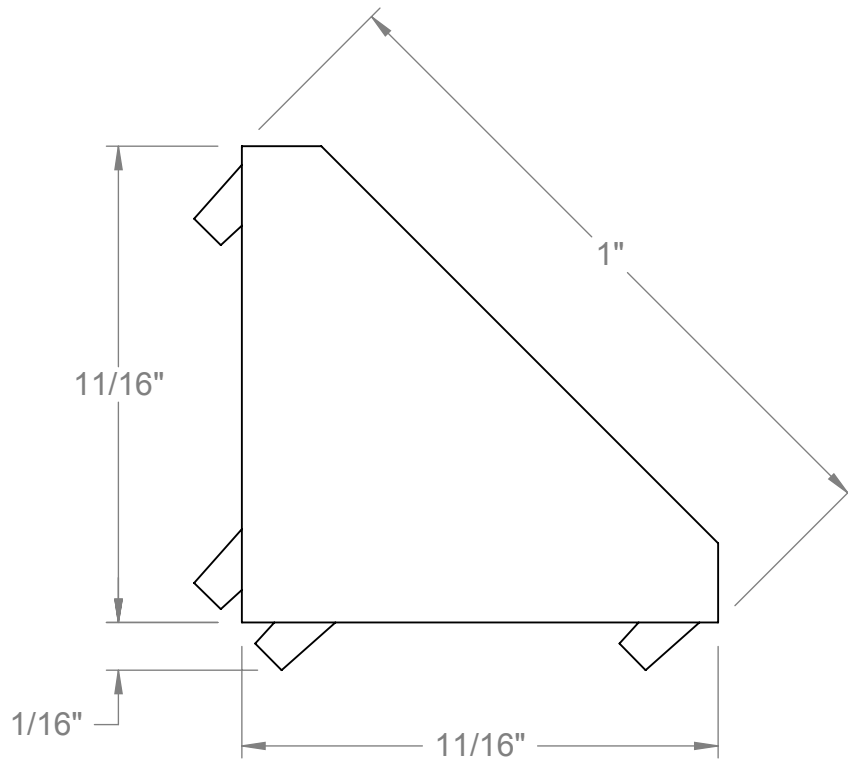
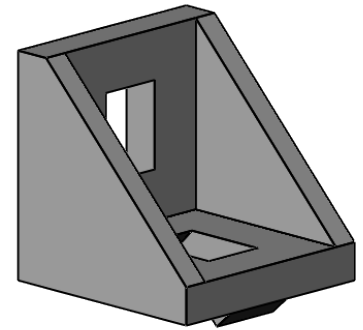

**McMASTER-CARR** CAD

PART NUMBER

**S 2.50 PT**

<http://www.mcmaster.com>  
 © 2015 McMaster-Carr Supply Company

90° Brace for  
 Aluminum T-Slotted Framing

Information in this drawing is provided for reference only.

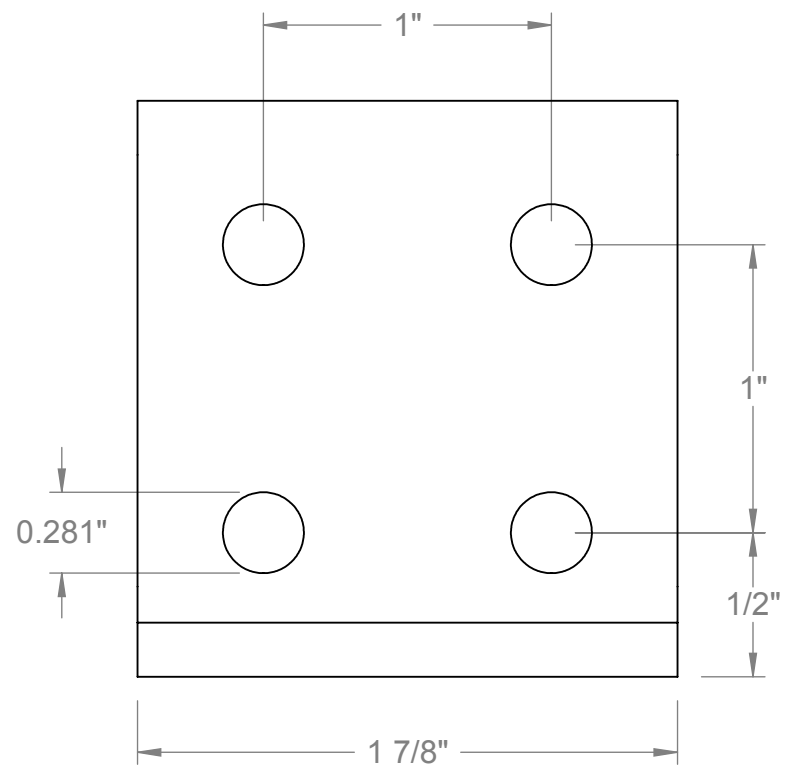
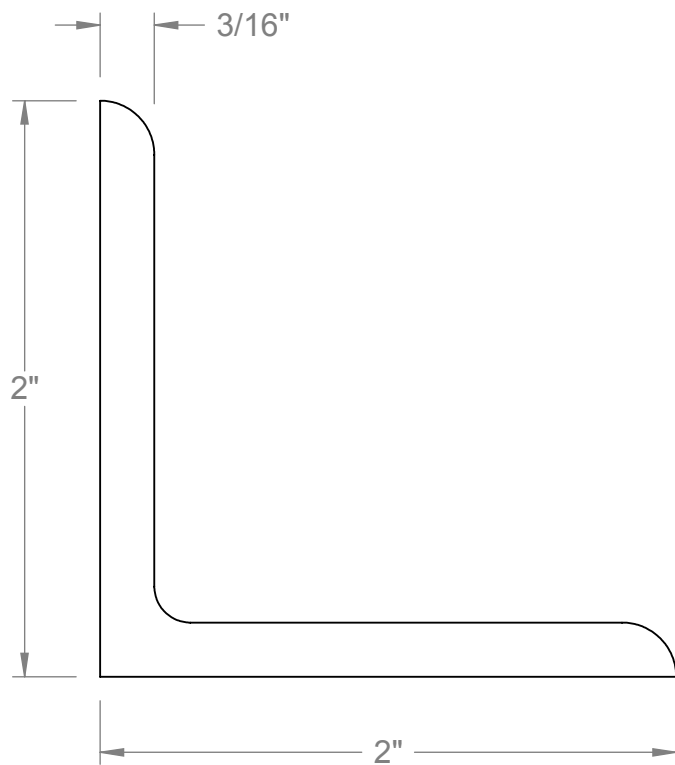
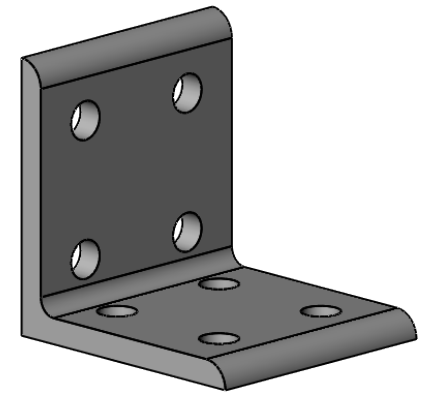

**McMASTER-CARR** CAD PART NUMBER **S 2.30 PT**

<http://www.mcmaster.com>  
© 2015 McMaster-Carr Supply Company

Information in this drawing is provided for reference only.

Extended 90° Bracket for  
Aluminum T-Slotted Framing

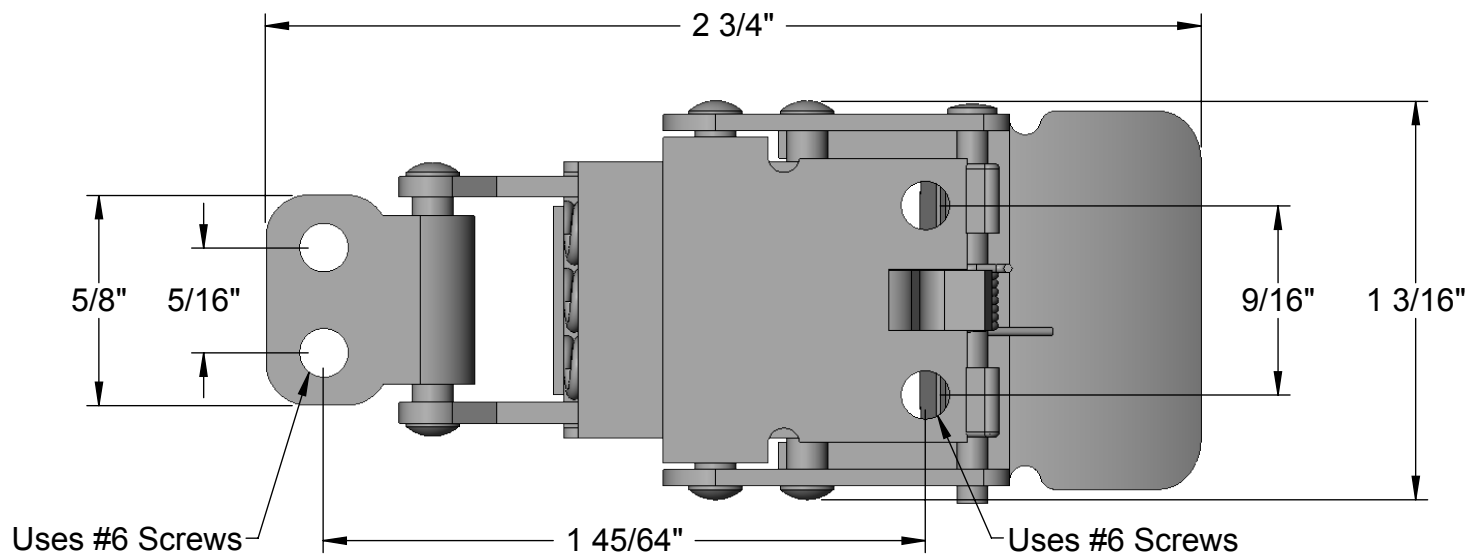
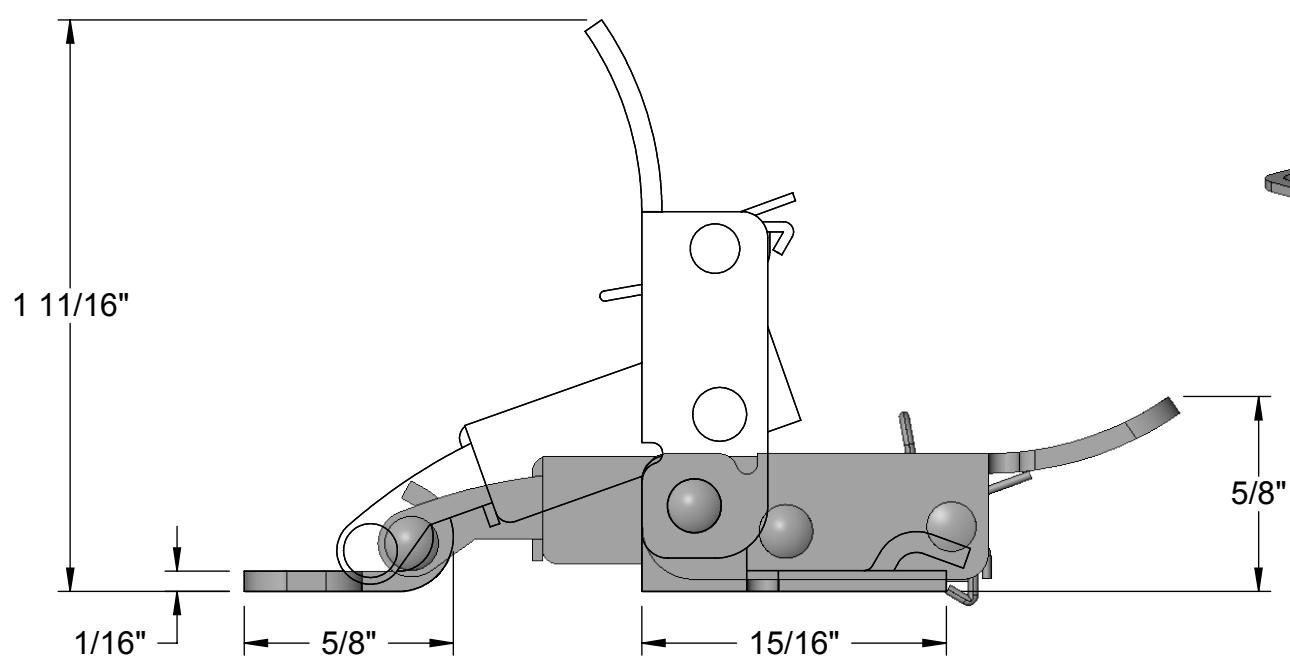

Latch Distance is 1 5/16"

**McMASTER-CARR** CAD

PART NUMBER

**PMH 4.10 PT**

<http://www.mcmaster.com>  
© 2012 McMaster-Carr Supply Company

Spring Tension  
Draw Latch

Information in this drawing is provided for reference only.

# G5757 Parts Breakdown and List

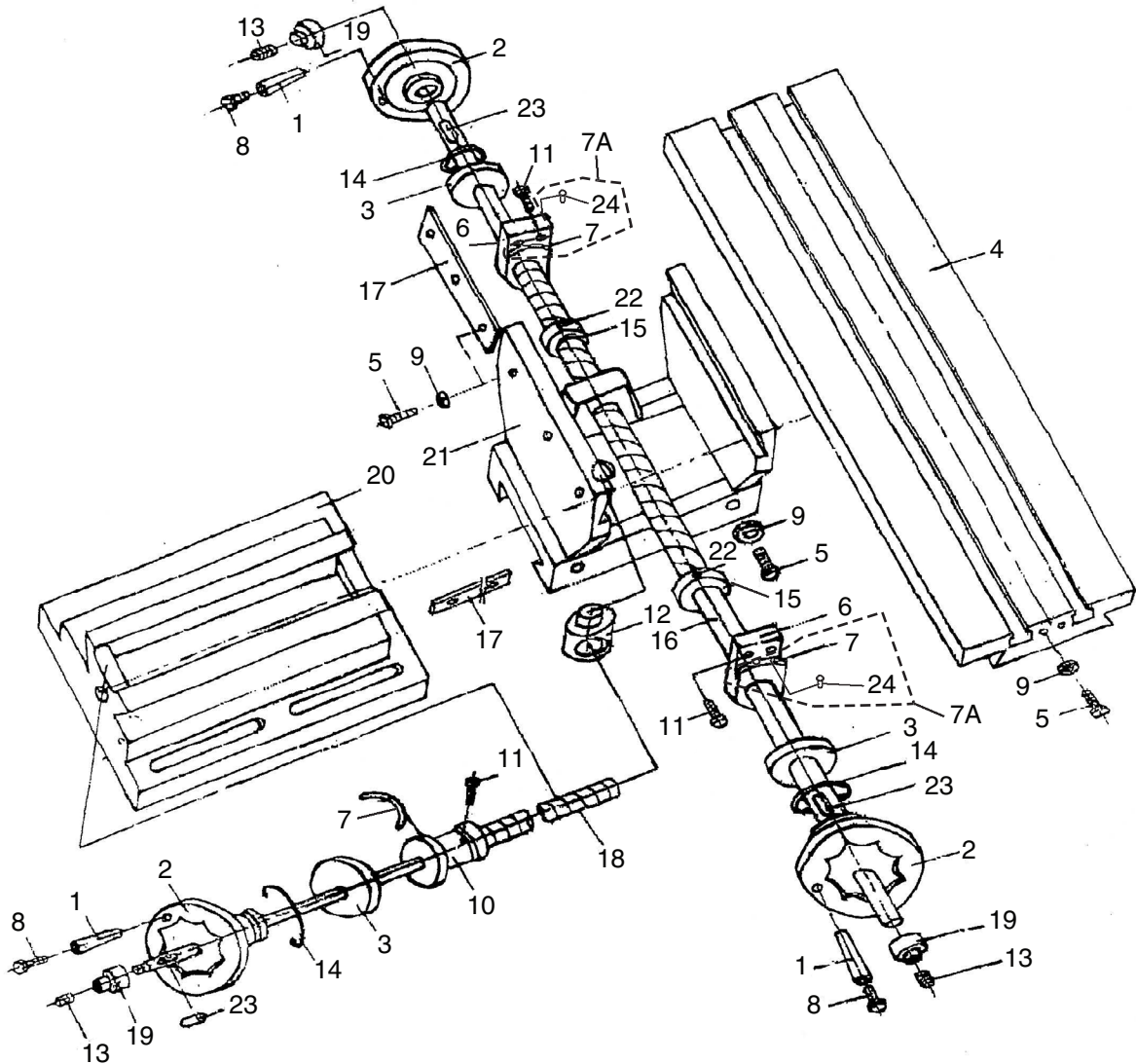

REF	PART #	DESCRIPTION
1	P8750001	HANDWHEEL HANDLE
2	P8750002	HANDWHEEL
3	P8750003	GRADUATED DISC
4	P8750004	TABLE
5	PSS28M	SET SCREW M6-1 X 30
6	P8750006	LEADSCREW SUPPORT BLOCK
7	P8750007	INDICATOR SCALE
7A	P8750007A	SCALE W/RIVETS 1" SET
8	P8750008	HANDWHEEL HANDLE SCREW M6-1 X 47
9	PN01M	HEX NUT M6-1
10	P8750010	CROSS LEADSCREW FLANGE
11	PCAP14M	CAP SCREW M8-1.25 X 20
12	P8750012	CROSS LEADSCREW NUT

REF	PART #	DESCRIPTION
13	PSS17M	SET SCREW M8-1.25 X 6
14	P8750014	STEEL SPRING
15	P8750015	STOP COLLAR
16	P8750016	LONGITUDINAL LEADSCREW
17	P8750017	GIB
18	P8750018	CROSS LEADSCREW
19	P8750019	LOCK NUT
20	P8750020	BASE
21	P8750021	CROSS SLIDE
22	PSS02M	SET SCREW M6-1 X 6
23	PK05M	KEY 4 X 4 X 10
24	P8750024	ALUMINUM RIVET 2.3 X 3.65MM

Parts breakdown provided for reference only. Not all parts shown are available for purchase.



DRAWING NO.  
HA 7.01 EX



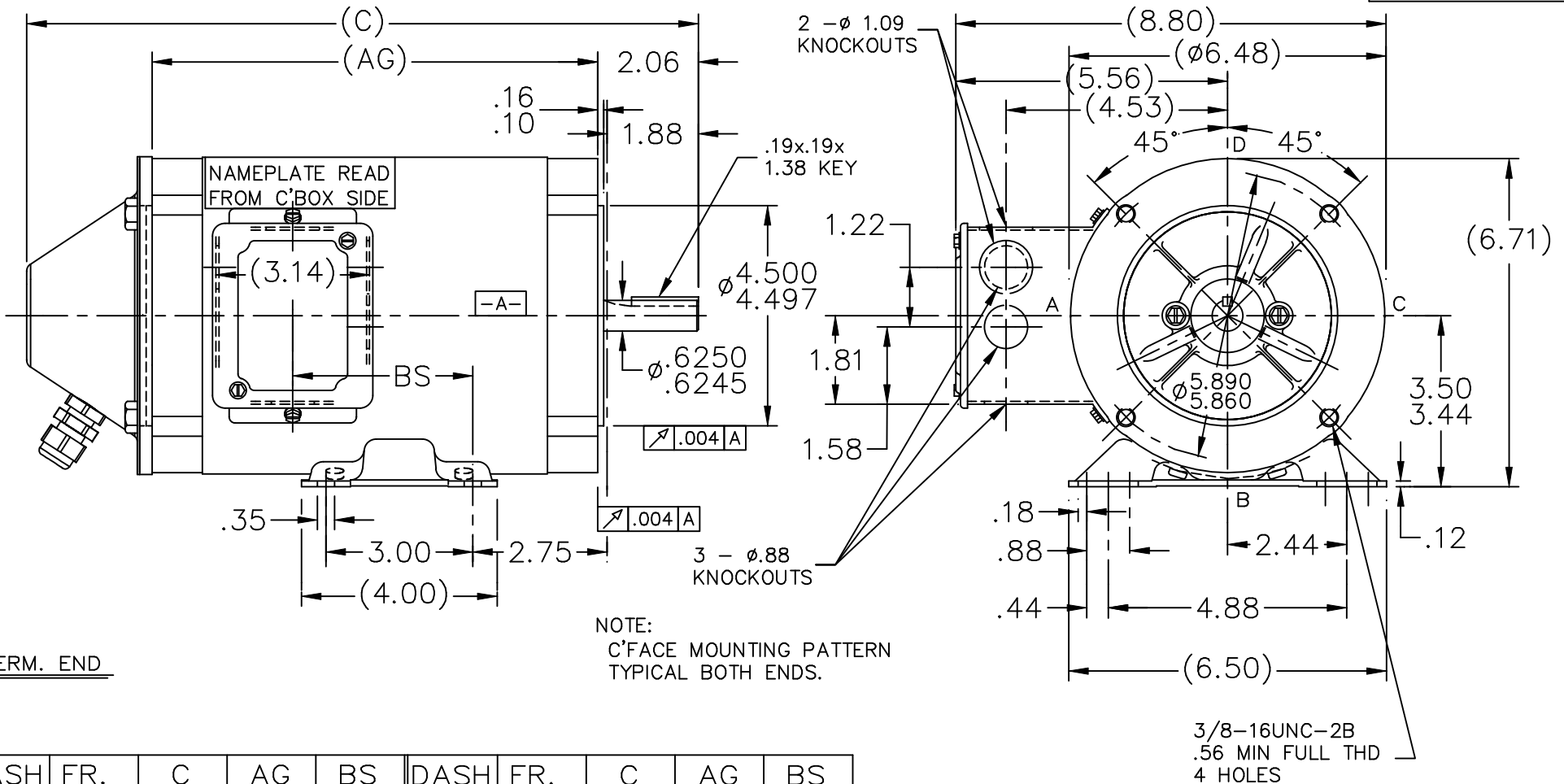

NOTE:  
C'FACE MOUNTING PATTERN  
TYPICAL BOTH ENDS.

TERM. END

DASH	FR.	C	AG	BS	DASH	FR.	C	AG	BS
					756	56-75	14.24	9.61	4.25
606	56-60	12.74	8.11	2.75	806	56-80	14.74	10.11	4.75
656	56-65	13.24	8.61	3.25	856	56-85	15.24	10.61	5.25
706	56-70	13.74	9.11	3.75					

NOTES:  
1. REMOVABLE BASE  
2. CONDUIT BOX CAN BE ROTATED 180°.

				TOLERANCES UNLESS SPECIFIED			DRAWN JJB 03-26-2008			
				DEC.	INCHES		CHK ML 03-27-2008			
				.X	±.1		APPD GK 03-27-2008			
				.XX	±.03		SCALE 5=16			
				.XXX	±.005		REF 104043A			
				.XXXX	±.0005	TITLE OUTLINE - HS 20 TACH. 56 FR. - TENV - BB - DBL. C'FACE	FMF MU86303			
				ANG	±7'30"	MAT'L.	PREV ME080078			
NO.	REVISION			BY & DATE		FINISH	RFP			
THIS DRAWING IN DESIGN AND DETAIL IS OUR PROPERTY AND MUST NOT BE USED EXCEPT IN CONNECTION WITH OUR WORK ALL RIGHTS OF DESIGN AND INVENTION ARE RESERVED THIS IS AN ELECTRONICALLY GENERATED DOCUMENT - DO NOT SCALE THIS PRINT						CAD FILE 107388	SIZE A	DRAWING NO. 107388	PAGE OF	REV.
						DIST WP				

EE7308

THREE PHASE  
DUAL VOLTAGE MOTOR

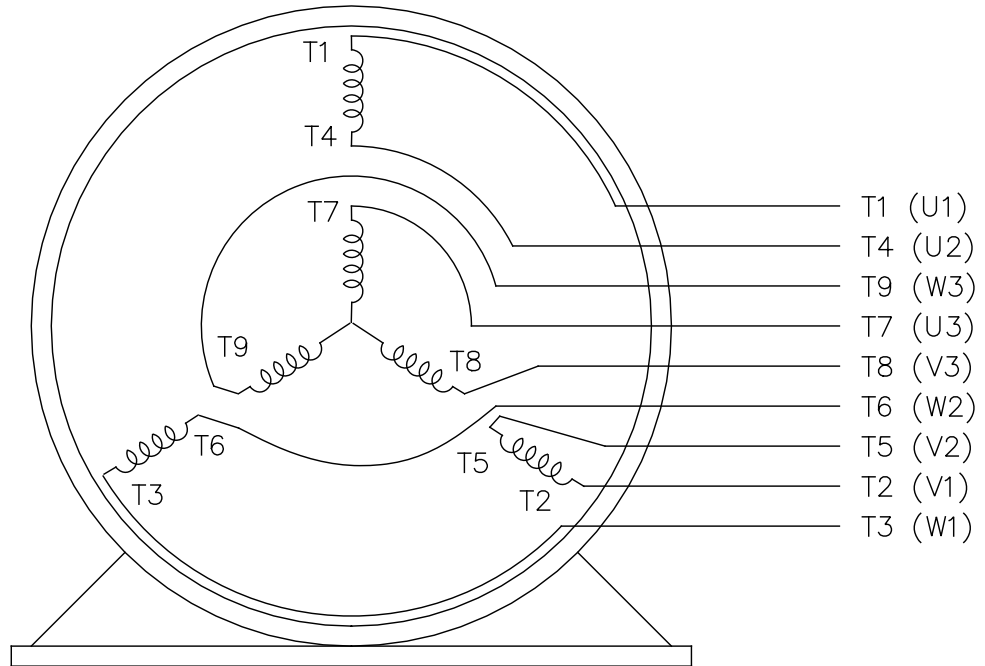
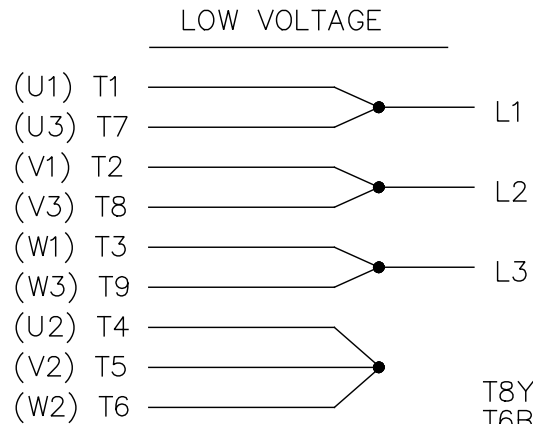
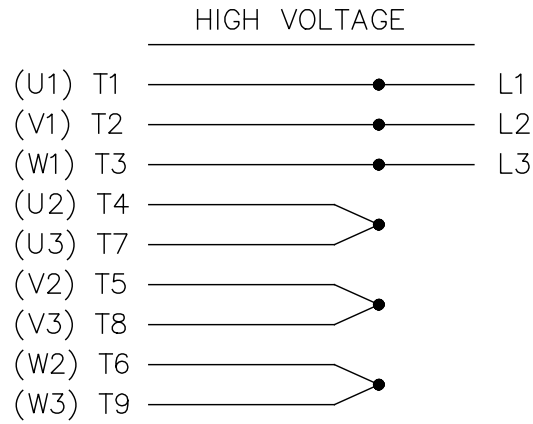

VIEW OF TERMINAL END

REF.  
WINDING DIAGRAM

T8Y, T2Y, T2BL, T4BX, T2EC, T2G  
T6BZ, T2B, T6BL, T4AV, T6B, T4B

OPTIONAL CORD  
CONNECTION

L1 — WHITE  
L2 — RED  
L3 — BLACK

NO.	REVISION	BY & DATE	CHK	ANG	TOLERANCES UNLESS SPECIFIED		FINISH	DRAWN RM 11/20/1990				
					DEC.	INCHES						
5	CHG TO REGAL LOGO	SL 09/10/2015	AB					CHK ML 11/21/1990				
4	REVISED IEC NOTATIONS	MSG 11/15/2011	CMN	.X	±.1			APPD SAS 04/24/2003				
3	ADDED IEC NOTATIONS... (U1), (V1) ETC. MU95194	MSG 5/10/2010	MJS	.XX	±.02		TITLE CONNECTION DIAGRAM	SCALE 1=1				
2	ADDED THE OPTIONAL CORD CONNECTION MU46318	RDH 04/24/2003	DRS	.XXX	±.005		3Ø - DUAL VOLTAGE MOTOR	REF				
1	REDRAWN	RM 11/20/1990		.XXXX	±.0005		MAT'L.	FMF				
					±7'30"			PREV				
THIS DRAWING IN DESIGN AND DETAIL IS OUR PROPERTY AND MUST NOT BE USED EXCEPT IN CONNECTION WITH OUR WORK ALL RIGHTS OF DESIGN AND INVENTION ARE RESERVED THIS IS AN ELECTRONICALLY GENERATED DOCUMENT - DO NOT SCALE THIS PRINT							RFP	CAD FILE ee7308	SIZE A	DRAWING NO. EE7308	PAGE OF 5	REV. 5
							DIST WP					

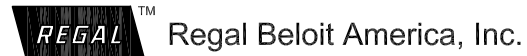

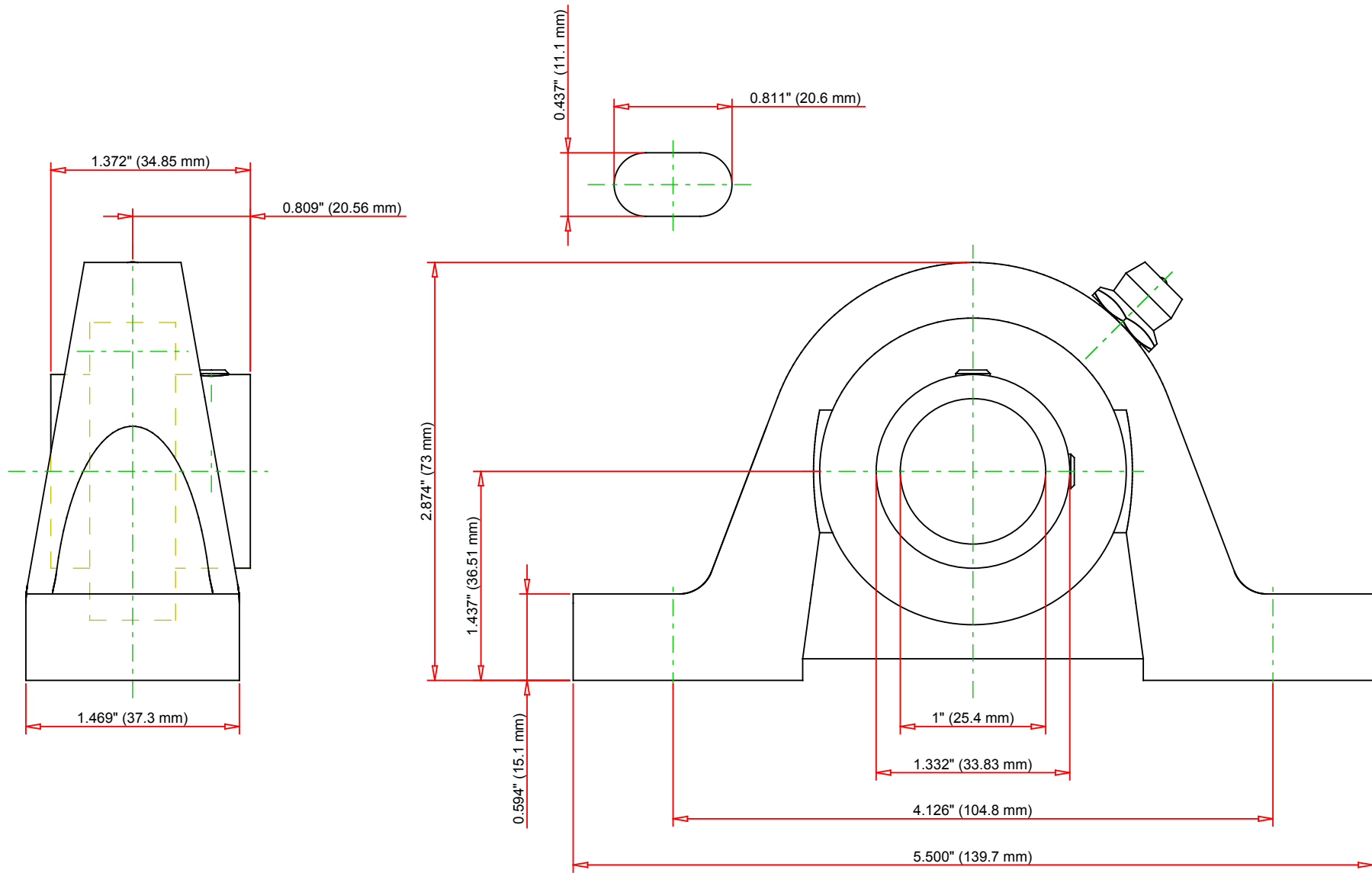

Bearing Number	GY1100KRRB SGT			
Load Ratings - C <sub>r</sub>	3550	lbf	15800	N
Load Ratings - C <sub>0r</sub>	1730	lbf	7700	N
Weight	2.102	lb	0.9535	kg
Bolt Size	M6x1			

**TIMKEN**

THE TIMKEN COMPANY  
NORTH CANTON, OHIO USA

**S 2.20 PT**  
Fafnir® Pillow Block Units Setscrew Locking

Every reasonable effort has been made to ensure the accuracy of the information contained in this writing, but no liability is accepted for errors, omissions or for any other reason.

**FOR DISCUSSION ONLY**

4

3

2

1

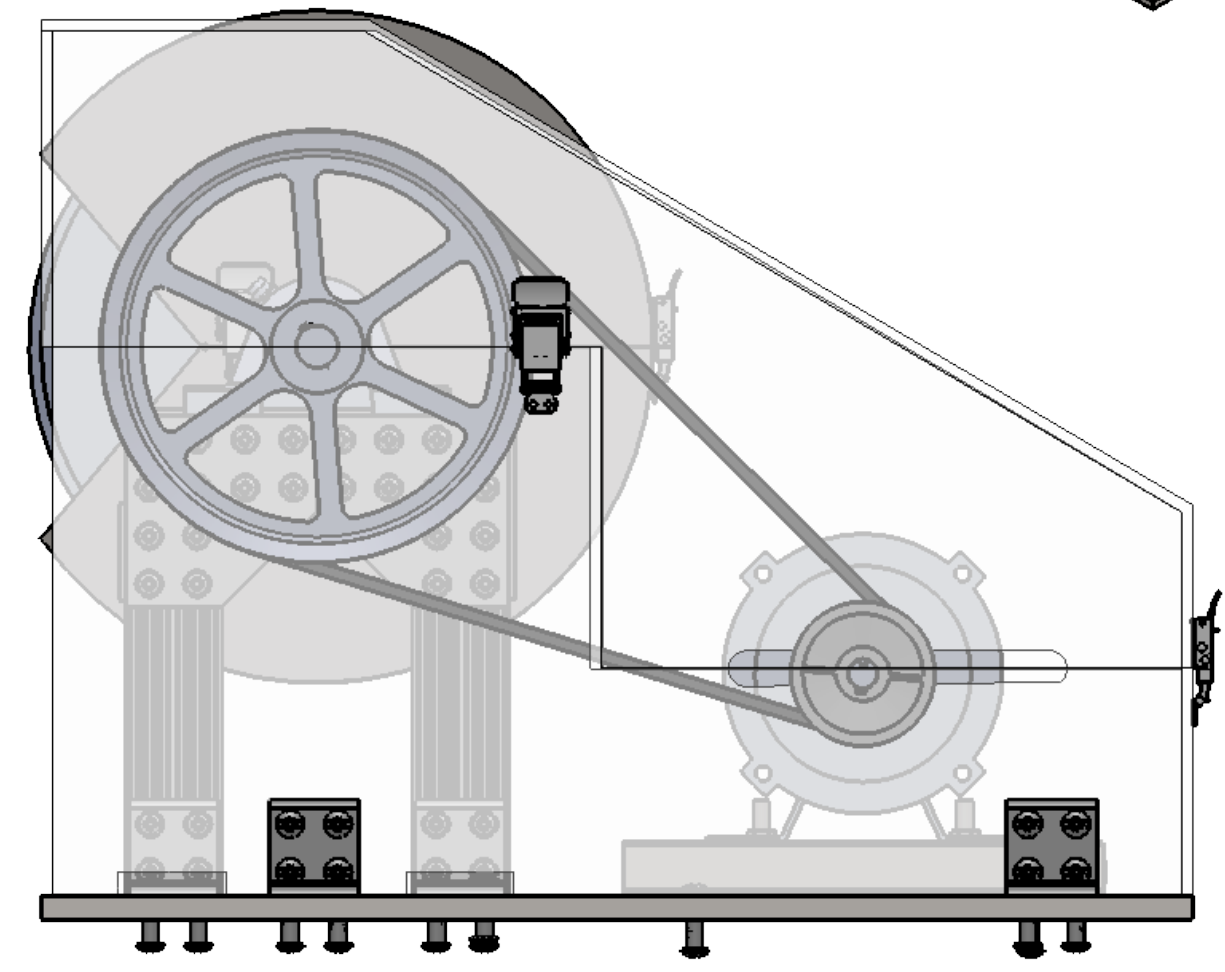
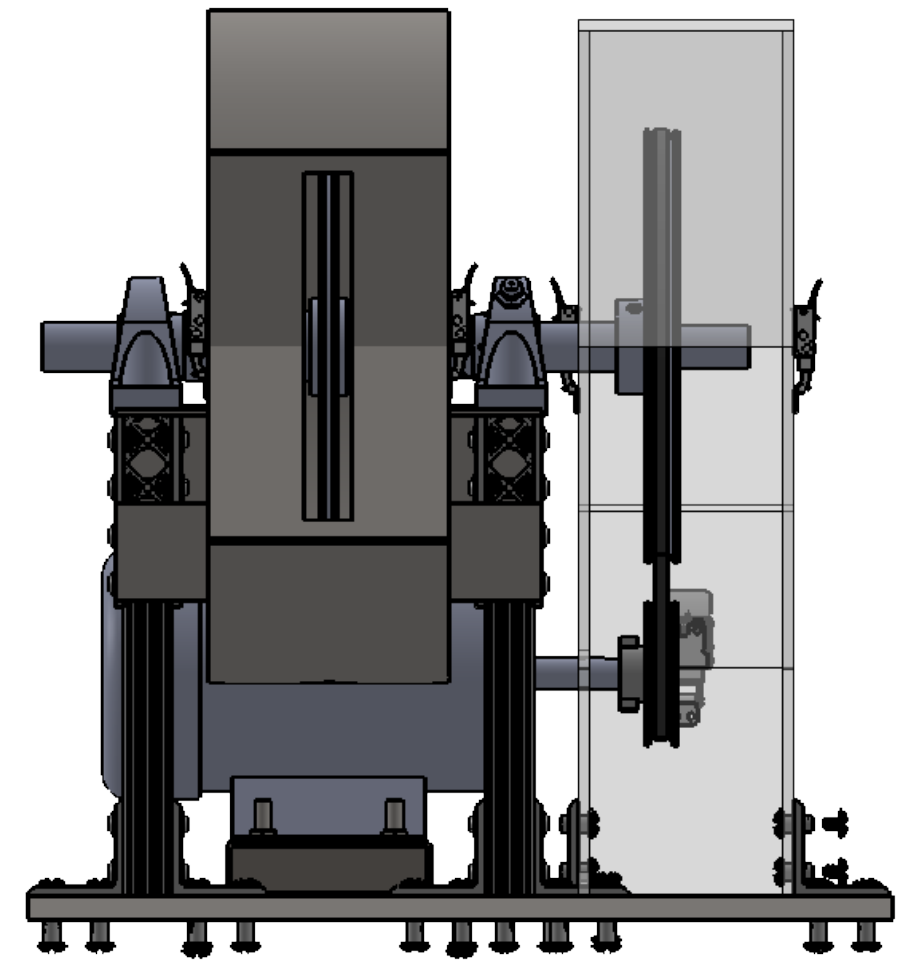
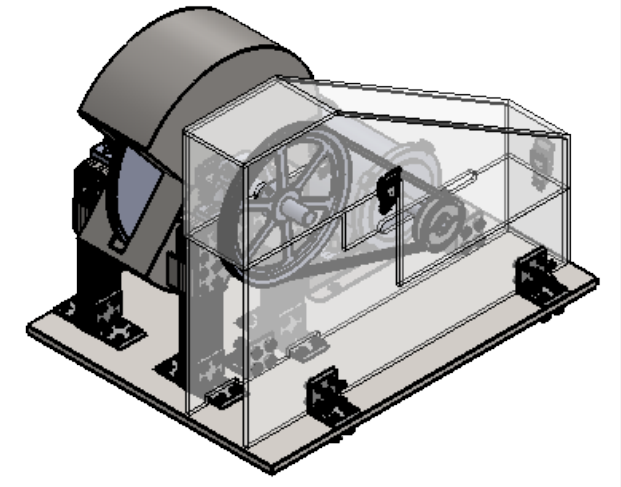

B

B

A

A

UNLESS OTHERWISE SPECIFIED:		NAME	DATE
DIMENSIONS ARE IN INCHES TOLERANCES: X.XX = ±0.01 X.XXX = ±0.001		DRAWN	SW 05/02/2018
INTERPRET GEOMETRIC TOLERANCING PER:		CHECKED	
MATERIAL		ENG APPR.	
FINISH		MFG APPR.	
DO NOT SCALE DRAWING		Q.A.	
		COMMENTS:	
TITLE:			<b>MACHINE ASSEMBLY</b>
SIZE	DWG. NO.	REV	
<b>B</b>	<b>M 1.00 A</b>	<b>1</b>	
SCALE: 1:4		WEIGHT:	SHEET 1 OF 1

4

3

2

1

# PRODUCT INFORMATION PACKET

Model No: 056H17T15526  
Catalog No: Y280  
1/2, 1800, TENV, 56C, 3/60/230/460  
1000:1 with Encoder



Regal and Marathon are trademarks of Regal Beloit Corporation or one of its affiliated companies.

©2018 Regal Beloit Corporation, All Rights Reserved. MC017097E





### Nameplate Specifications

Output HP	<b>0.5 Hp</b>	Output KW	<b>0.37 kW</b>
Frequency	<b>60 Hz</b>	Voltage	<b>230/460 V</b>
Current	<b>1.6/0.8 A</b>	Speed	<b>1725 rpm</b>
Service Factor	<b>1</b>	Phase	<b>3</b>
Efficiency	<b>80 %</b>	Duty	<b>CONTINUOUS</b>
Insulation Class	<b>H</b>	Design Code	<b>INV</b>
KVA Code	<b>L</b>	Frame	<b>56C</b>
Enclosure	<b>TENV</b>	Overload Protector	<b>NOT</b>
Ambient Temperature	<b>40 °C</b>	Drive End Bearing Size	<b>6203</b>
Opp Drive End Bearing Size	<b>6203</b>	UL	<b>Recognized</b>
CSA	<b>Y</b>	CE	<b>Y</b>
IP Code	<b>43</b>		

### Technical Specifications

Electrical Type	<b>SQ CAGE INV DUTY</b>	Starting Method	<b>INVERTER ONLY</b>
Poles	<b>4</b>	Rotation	<b>REV</b>
Mounting	<b>BOLT-ON</b>	Motor Orientation	<b>HORIZONTAL</b>
Drive End Bearing	<b>BALL</b>	Opp Drive End Bearing	<b>BALL</b>
Frame Material	<b>ROLLED STEEL</b>	Shaft Type	<b>STANDARD 56</b>
Overall Length	<b>13.74 in</b>	Frame Length	<b>7.06 in</b>
Shaft Diameter	<b>0.63 in</b>	Shaft Extension	<b>2.06 in</b>
Assembly/Box Mounting	<b>F1 ONLY</b>		
Outline Drawing	<b>A-107388-706</b>	Connection Diagram	<b>A-EE7308</b>

This is an uncontrolled document once printed or downloaded and is subject to change without notice. Date Created: 04/05/2018

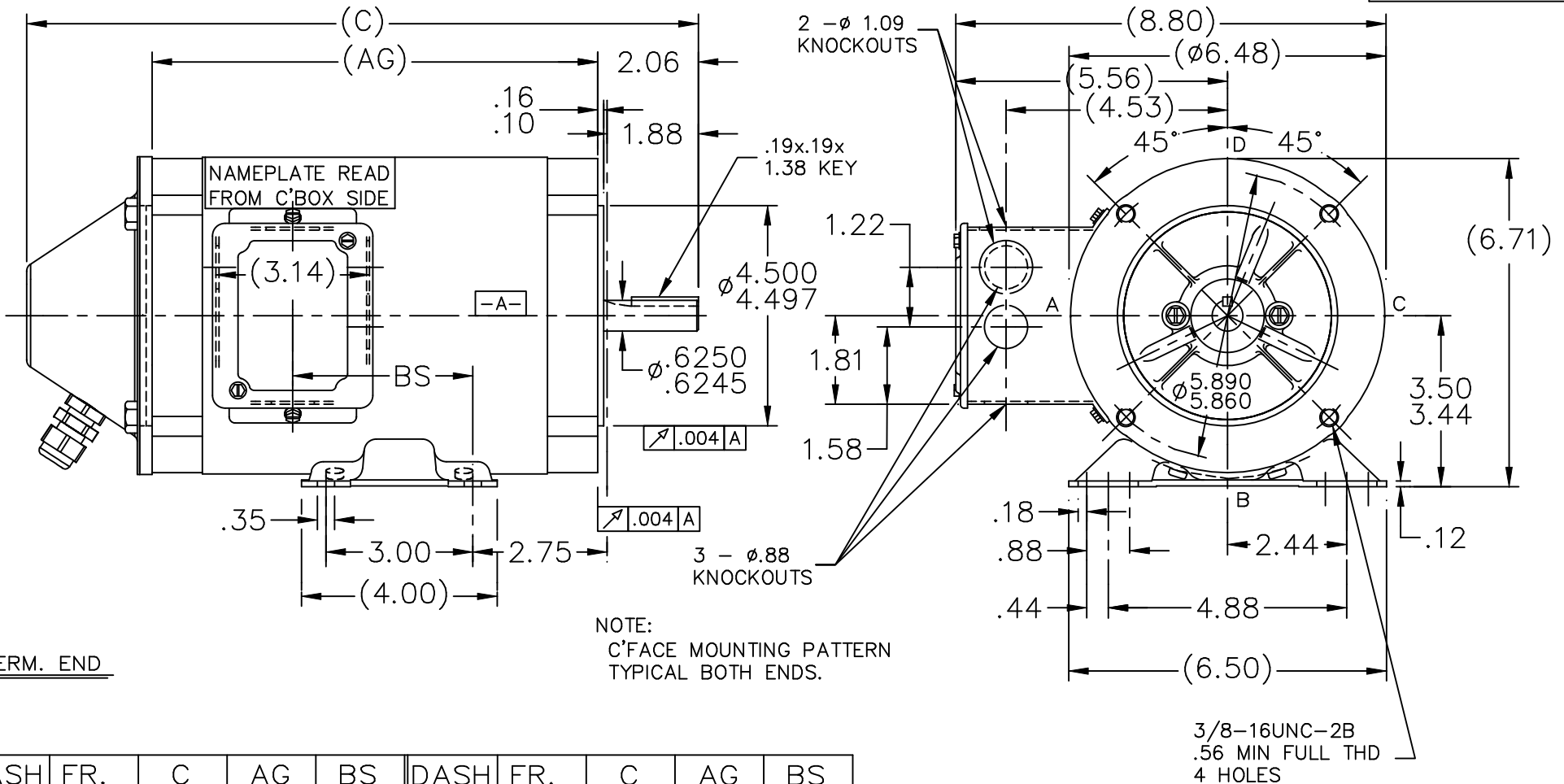

TERM. END

DASH	FR.	C	AG	BS	DASH	FR.	C	AG	BS
					756	56-75	14.24	9.61	4.25
606	56-60	12.74	8.11	2.75	806	56-80	14.74	10.11	4.75
656	56-65	13.24	8.61	3.25	856	56-85	15.24	10.61	5.25
706	56-70	13.74	9.11	3.75					

- NOTES:  
 1. REMOVABLE BASE  
 2. CONDUIT BOX CAN BE ROTATED 180°.

				TOLERANCES UNLESS SPECIFIED			DRAWN JJB 03-26-2008				
				DEC.	INCHES		CHK ML 03-27-2008				
				.X	±.1		APPD GK 03-27-2008				
				.XX	±.03		SCALE 5=16				
				.XXX	±.005		REF 104043A				
				.XXXX	±.0005	TITLE OUTLINE - HS 20 TACH. 56 FR. - TENV - BB - DBL. C'FACE	FMF MU86303				
NO.	REVISION	BY & DATE	CHK	ANG	±7'30"	MAT'L.	PREV ME080078				
THIS DRAWING IN DESIGN AND DETAIL IS OUR PROPERTY AND MUST NOT BE USED EXCEPT IN CONNECTION WITH OUR WORK ALL RIGHTS OF DESIGN AND INVENTION ARE RESERVED THIS IS AN ELECTRONICALLY GENERATED DOCUMENT - DO NOT SCALE THIS PRINT				RFP		CAD FILE 107388	SIZE	DRAWING NO.	PAGE	OF	REV.
				DIST	WP		A	107388			

EE7308

THREE PHASE  
DUAL VOLTAGE MOTOR

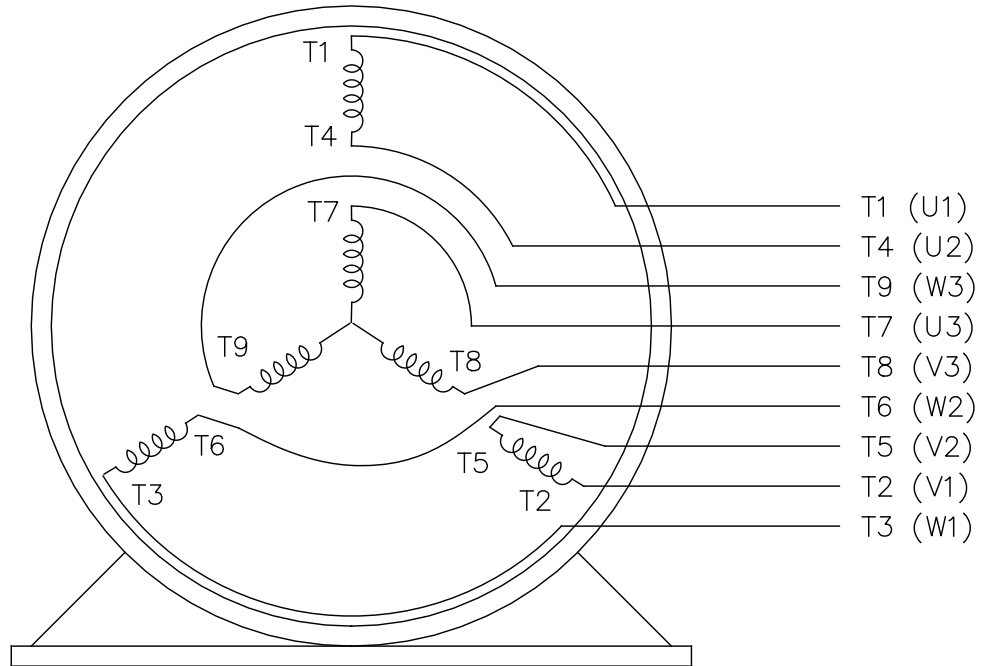
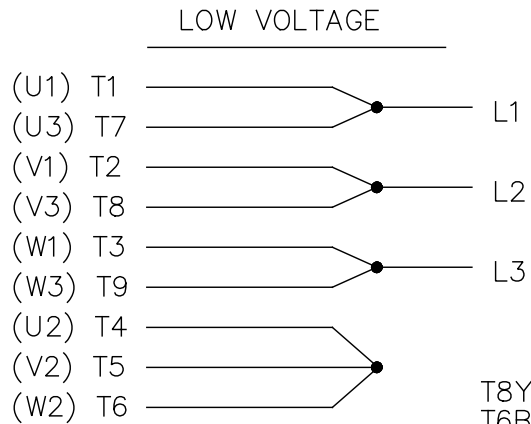
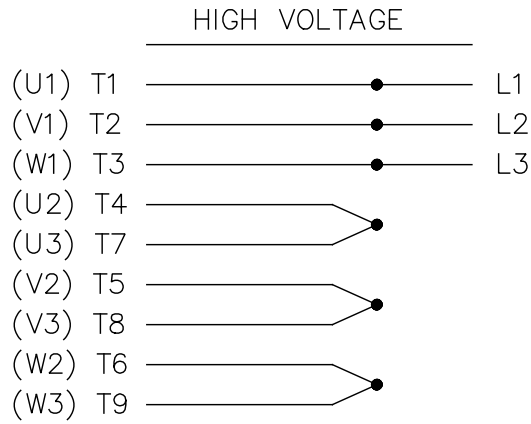

VIEW OF TERMINAL END

REF.  
WINDING DIAGRAM

T8Y, T2Y, T2BL, T4BX, T2EC, T2G  
T6BZ, T2B, T6BL, T4AV, T6B, T4B

OPTIONAL CORD  
CONNECTION

L1 — WHITE  
L2 — RED  
L3 — BLACK

NO.	REVISION	BY & DATE	CHK	ANG	TOLERANCES UNLESS SPECIFIED		FINISH	DRAWN RM 11/20/1990				
					DEC.	INCHES						
5	CHG TO REGAL LOGO	SL 09/10/2015	AB					CHK ML 11/21/1990				
4	REVISED IEC NOTATIONS	MSG 11/15/2011	CMN	.X	±.1			APPD SAS 04/24/2003				
3	ADDED IEC NOTATIONS... (U1), (V1) ETC. MU95194	MSG 5/10/2010	MJS	.XX	±.02			SCALE 1=1				
2	ADDED THE OPTIONAL CORD CONNECTION MU46318	RDH 04/24/2003	DRS	.XXX	±.005		TITLE CONNECTION DIAGRAM 3Ø - DUAL VOLTAGE MOTOR	REF				
1	REDRAWN	RM 11/20/1990		.XXXX	±.0005		MAT'L.	FMF				
					±7'30"			PREV				
THIS DRAWING IN DESIGN AND DETAIL IS OUR PROPERTY AND MUST NOT BE USED EXCEPT IN CONNECTION WITH OUR WORK ALL RIGHTS OF DESIGN AND INVENTION ARE RESERVED THIS IS AN ELECTRONICALLY GENERATED DOCUMENT - DO NOT SCALE THIS PRINT							RFP	CAD FILE ee7308	SIZE A	DRAWING NO. EE7308	PAGE OF 5	REV. 5
							DIST WP					

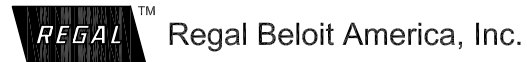





NONE	P/N	NONE	
NONE	NONE		
NONE FT-LB	NONE V	NONE Hz	

DATE: 06/28/2017 01:07:04 AM  
FORM 3531 REV.3 02/07/99  
\*\* Subject to change without notice.

Data Sheet

Date: 3/1/2018  
 Customer: \_\_\_\_\_  
 Attention: \_\_\_\_\_  
 Submitted by: \_\_\_\_\_



56H17T15526

Submittal

Data @ 460 V

Motor Load Data

Load	0%	25%	50%	75%	100%	115%	125%	LR
Current (Amps)	0.52	0.55	0.60	0.70	0.80	0.95	1.00	5.6
Torque (ft-lb)	0.00	0.37	0.75	1.10	1.52	1.70	1.90	4.6
RPM	1800	1785	1775	1760	1735	1,735	1725	0
Efficiency (%)		63.5	75.0	78.5	80.0	80.1	79.5	
P.F. (%)	11.0	33.5	50.5	63.0	72.0	71.5	77.0	69.5

Motor Speed Data

	LR	Pull-Up	BD	Rated	Idle
Speed (RPM)	0	800	1330	1735	1800
Current (Amps)	5.6	5.0	3.5	0.80	0.52
Torque (ft-lb)	4.6	4.2	5.8	1.52	0.00

Information Block				
HP	0.5			
Sync. RPM	1800			
Frame	56			
Enclosure	TENV			
Construction	TTR			
Voltage	230/460 V			
Frequency	60 Hz			
Design	B			
LR Code letter	L			
Service Factor	1.15			
Temp Rise @ FL	55 °C			
Duty	CONT			
Ambient	40 °C			
Elevation	1,000 feet			
Rotor/Shaft wk <sup>2</sup>	0.06 Lb-Ft <sup>2</sup>			
Ref Wdg	ZT471 F			
Sound Pressure @ 1M	62 dBA			
VFD Rating	CONSTANT 1000:1			
Outline Dwg	A-107388-706			
Conn. Diag	A-EE7308			
Additional Specifications:				
0				
0				
EQUIV CKT (OHMS / PHASE)				
R1	R2	X1	X2	Xm
22.3070	17.0280	24.1230	18.1630	532.9760

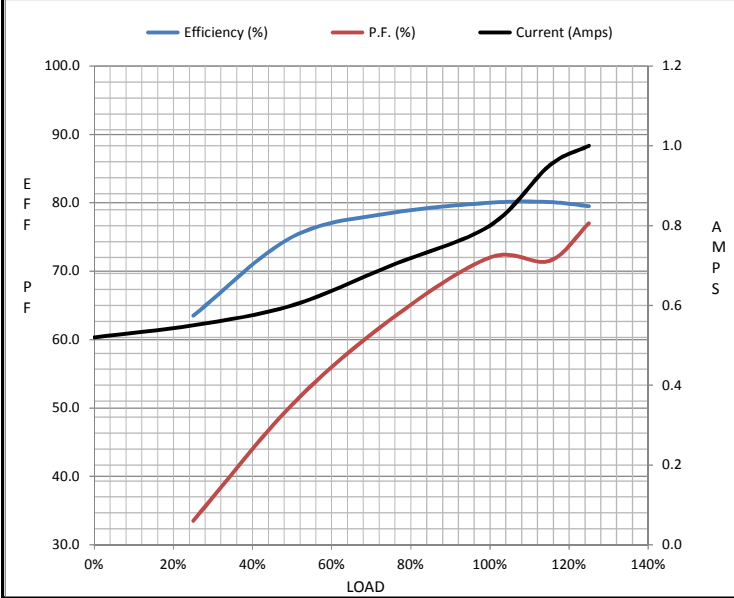

Speed - Torque Curve

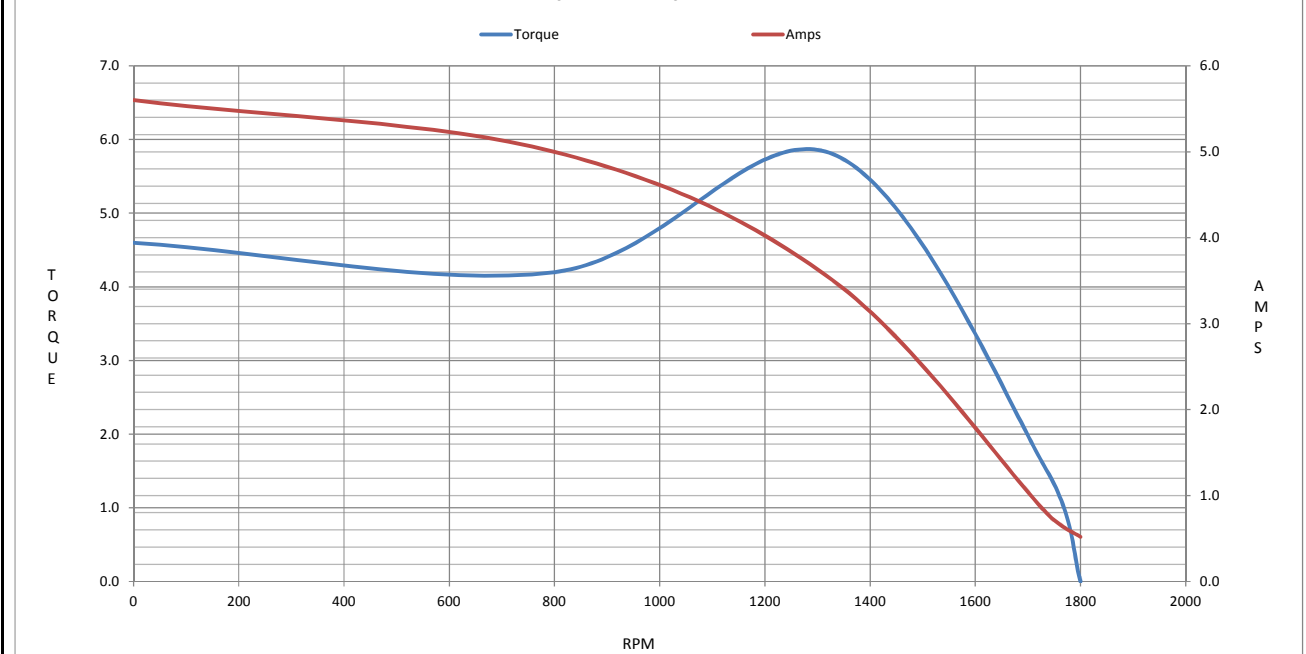

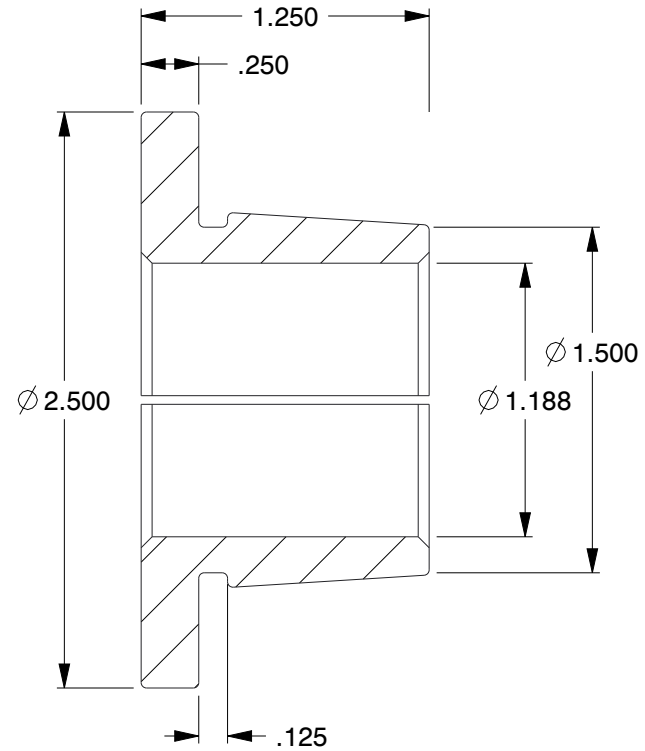
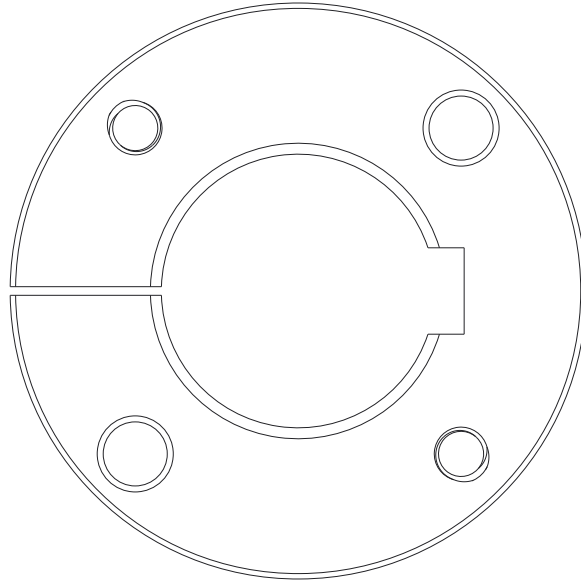
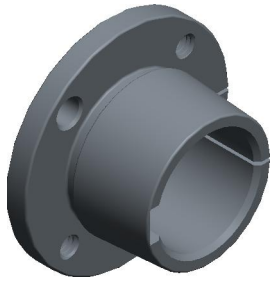

**NOTES:**

1. Bushing Size: QT
2. Bolt Circle Dia: 2"
3. Bolt Size: 1/4-20" x 1"
4. Taper Angle: 3/4" Per ft. On Diameter
5. Length: 1-1/4"
6. Material: Steel
7. SAE Grade: 5
8. Package Quantity: 1
9. Includes: Cap Screws
10. Power Transmission Type: QD Bushing

<b>COMPONENT</b>		<b>QUICK DETACHABLE BUSHING</b>	
<h1>5UHZ7</h1>		<b>UNIT</b>	INCH
		<b>SHEET</b>	1 of 1
		QD Bushing, Series QT, Bore Dia 1-3/16 In	



100 Grainger Parkway, Lake Forest, Illinois 60045-5201  
 1-(800) GRAINGER, 1-(800) 472-4643, (847) 535-1000  
 www.grainger.com

This file and any associated information and specifications are provided for reference and evaluation purposes only, and is subject to change without notice. Grainger makes no representations, warranties or guarantees as to the appropriateness, accuracy, completeness, or suitability for any purpose, of the file, information or specifications. You are solely responsible for the use of the file, information or specifications.

This drawing is the property of GRAINGER. It contains confidential, proprietary information that is GRAINGER property. Do not disclose to or duplicate for others except as authorized by GRAINGER.

**SCALE** 1.20