

# *“Rusty” the Mustang*

*California Polytechnic State University, San Luis Obispo  
Architectural Engineering*

*By: Ryan Llamas & Jack Tenley*

*Adviser*

*Dr. Craig Baltimore, PhD, SE*

*June 2017*

## Table of Contents

<b>Table of Contents</b>	<b>1</b>
<b>1.0 Introduction</b>	<b>2</b>
1.1 Reasons for doing this Project	3
1.2 What We Set Out to Accomplish	3
1.3 Approach to the Design Process	3
<b>2.0 Structural Design Process</b>	<b>4</b>
2.1 Assessing the First Draft	4
2.2 Analysis of Loading on the Sculpture	5
2.3 Lateral Loads	5
2.3.1 Seismic Loading	6
2.3.2 Wind Loading	7
2.4 Loading from People	8
2.5 Design of Footing and Anchorage	9
2.6 Constructability Considerations	14
<b>3.0 Final Submittal for Facilities</b>	<b>15</b>
3.1 Permit Process	15
3.1.1 Site Approval	15
3.1.2 Calc Package Submittal	16
<b>4.0 Final Construction</b>	<b>18</b>
4.1 Pre-Construction Planning	18
4.2 Material Acquisition	19
4.3 Site Preparation	21
4.4 Foundation Construction	22
4.5 Rusty Installation	25
<b>5.0 Reflection</b>	<b>28</b>
<b>5.0 Works Cited</b>	<b>29</b>
<b>6.0 Appendix</b>	<b>29</b>

## 1.0 Introduction

*"Rusty" the mustang was a senior project in the Spring of 2016 where sixteen students worked together to design and build the steel sculpture with the help of artist Ivan McLean. The project was completed in ten weeks, and put on display in Kennedy Library as a part of "The Living Library" exhibit. Once the exhibit was over, the sculpture was disassembled and stored outdoors near building 21. In Fall 2016 two architectural engineering students made it their goal to find a permanent home for the sculpture somewhere on campus as part of their senior project. Their project consisted of analyzing the loading on the sculpture, designing a foundation for it, and working with Cal Poly facilities, the University Art Acquisition Committee, and different colleges to get the project permitted and installed. This initial permitting process provided valuable lessons and proved to take the entire effort of the team, however, due to delays during this process, "Rusty" the mustang never found that permanent home on campus. See reference section for the citations of published reports for these two projects.*

*In Spring 2017, a pair of architectural engineering students, Jack Tenley and Ryan Llamas, continued work on the sculpture as their senior project in order to finally place it somewhere on campus as part of the campus art collection. The scope of the project was to experience the phases of a real project through a microcosm, the Cal Poly protocols. Through collaboration between the students and campus facilities, "Rusty" the mustang was successfully installed between building 21 and building 186.*



*Figure 1: "Rusty" the Mustang final installation in front of the North face of building 21*

### *1.1 Reasons for doing this Project*

*After watching the first two teams of students work diligently to create "Rusty" and then try and find the sculpture a home, it seemed wrong that the work of art might not go on display permanently. Jack and Ryan believed they could build upon lessons learned and assist in bringing this project to completion. One of the hopes for this project was that it would serve as an example to future students of Cal Poly's learn by doing attitude.*

### *1.2 What We Set Out to Accomplish*

*The end goal of this project was to finally install "Rusty" the mustang permanently on campus in one of the planters between building 21 and building 186. Before this final goal could be met, many other milestones had to be accomplished. These milestones included designing the foundation for the sculpture, creating a package of calculations to be submitted to Cal Poly facilities, receiving a building permit, excavating the site, and pouring the concrete foundation. All of this needed to be completed in a timely manner in order to maintain the April to June timeline.*

### *1.3 Approach to the Design Process*

*Since this group of students was the third group to work on "Rusty" the mustang, a preliminary design for the sculpture's placement and foundation were available. This first draft was taken into consideration but was heavily revised for the final design. Much of the design process focused on the site constraints as well as the sculpture's constructability. After these two issues had been resolved the shape, orientation, and overall design of the foundation was considered. Several possible load cases were analyzed and applied to the sculpture while the foundation was being designed in order to come up with a product that was both safe and efficient.*

## 2.0 Structural Design Process

### 2.1 Assessing the First Draft

Before any new design was started, this team of students first looked at the work prior students had done on the design of the sculpture's foundation. One of the first concerns regarding the previous work that had been done were the loads used to design the dimensions of the foundation. These loads seemed suspiciously large, and upon further investigation were found to be an overestimate of the actual loads felt by the structure. Another concern this team had about the first draft of the foundation was the means of anchoring that had been called out. Originally the anchor bolts used to fasten the sculpture to the foundation were to be epoxied into the foundation after the concrete had been poured. Although this method of anchorage provides sufficient strength, it only does so if the drilled bolt holes are completely free of dust and debris. If the holes were not adequately clean, then there is a chance that the epoxy would not adhere correctly to the foundation causing its strength to significantly drop. After taking all of these concerns into account, it was decided that the layout of the foundation as well as the method of anchorage needed to be updated.

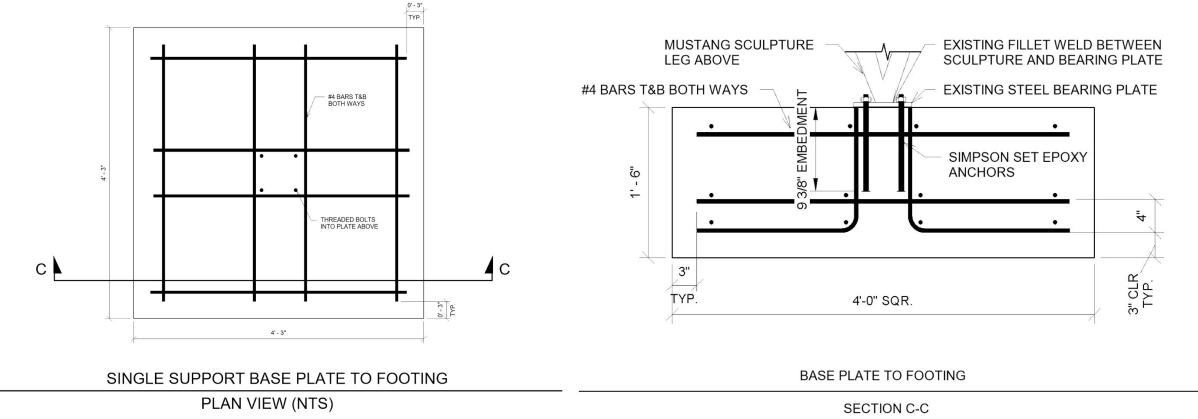

Figure 2: Previous foundation design

## 2.2 Analysis of Loading on the Sculpture

*In order to address the concerns stated in section 2.1 of this report, the sculpture needed to first be exposed to the different loads it might experience. This was done by using a model of the sculpture created by a past team of students in RISA, a structural analysis software. All loads and calculations were done in accordance with ASCE 7-10, and applied to the sculpture in RISA.*

*The model of the sculpture was essentially a series of members connected by nodes to create a truss system. This method of modeling was chosen because it most accurately represented what the physical sculpture looked like. Each member was assigned the correct shape and material so that the results could be as correct as possible. Assigning the correct structural properties to each member also allowed the team to get an idea of how much the sculpture weighed as well as where its center of gravity was. The center of gravity calculated by RISA was confirmed using hand calculations. Once this data had been correctly inputted, the students proceeded to load "Rusty".*

*Although all load cases were analyzed in RISA, the three cases that had the most significant effect on the sculpture were wind, seismic, and human loading. Applying these loads to the sculpture allowed the team to see what kind of reactions would occur at the three locations where the mustang would be anchored. Once these reactions had been recorded, they would be used to design the size and layout of the foundation. The next two sections of this report go into more detail on how these loads were applied.*

## 2.3 Lateral Loads

*Both wind and seismic loading were taken into consideration when determining the governing lateral force to apply to "Rusty". These forces were calculated by hand using equations from chapters 13 (seismic) and 29 (wind). Once both forces had been calculated, they were applied to the sculpture in RISA to determine which one produced the largest reactions at the base. Reactions recorded as uplift forces were the main concern for the team since the presence of these forces meant that the sculpture had the tendency to tip over.*

### 2.3.1 Seismic Loading

When calculating the seismic load, the sculpture was considered to be nonstructural since it is not a direct threat to human life in the event of an earthquake. Since this consideration was made, chapter 13 of the ASCE 7-10 (Seismic Design Requirements for Nonstructural Components) was used to calculate the design load. After calculating this load, the force was applied to the sculpture at its center of gravity using RISA. After analyzing the resulting reactions due to the seismic force, the team of students determined that seismic loading was not the governing lateral force. More detailed information on how this was determined can be found on pages 5-8 of the calculation package included in the appendix of this report.

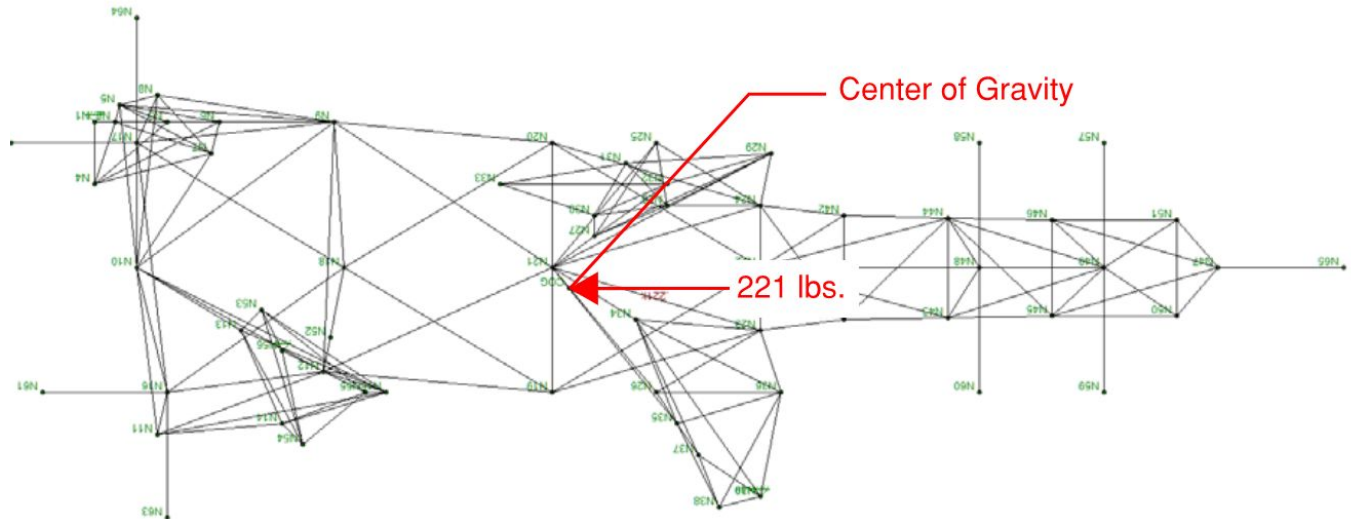

Figure 3: Placement of seismic force on sculpture

### 2.3.2 Wind Loading

The design wind load was calculated using chapter 29 of the ASCE 7-10 (Wind Loads on Other Structures and Building Appurtenances - MWFRS). The reason the team decided to use this chapter to determine the design wind load was because “Rusty” was considered to be open lattice framework. This definition felt most appropriate since the sculpture consisted of a series of trusses. Once the design wind load was calculated, the force was applied to the sculpture’s center of geometry using RISA. The resulting reactions created by the wind load proved that this force caused the largest uplift at the base of the sculpture, making it the governing case used to design the final foundation. More detailed information on how this was determined can be found on pages 5-8 of the calculation package included in the appendix of this report.

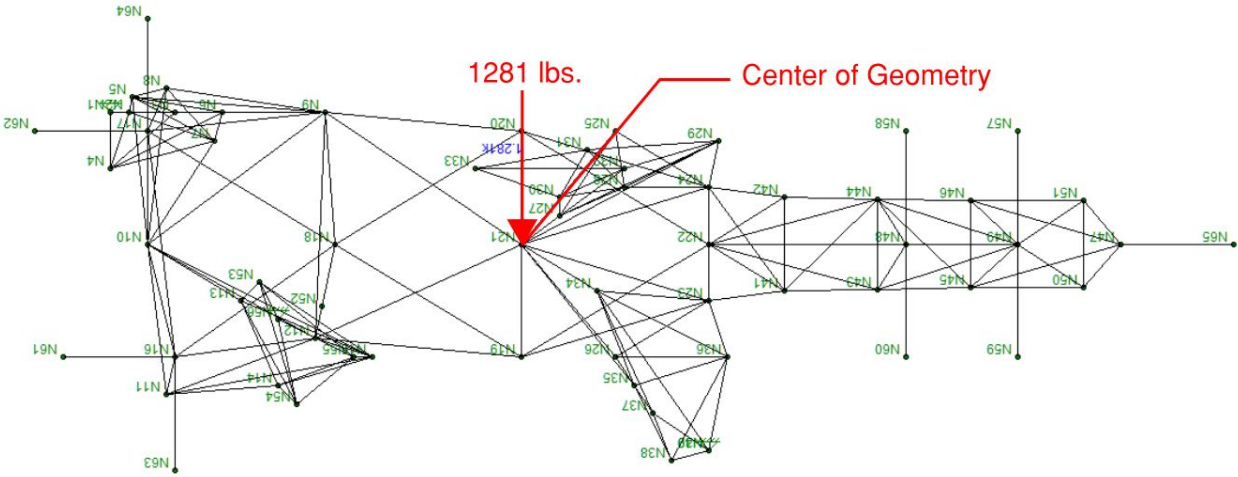

Figure 4: Placement of wind force on sculpture



### 2.4 Loading from People

Since “Rusty” the mustang would be placed on campus, there was concern that students may misuse the sculpture and attempt to hang from it or climb on top of it. Although building codes do not address issues such as these, the team felt it was necessary to take this load case into account because it potentially cause harm to the public. Analyzing situations like these allowed the team to exercise some engineering judgement as well as forced them to think critically about possible scenarios that may not occur on every project. Ultimately this load case did not govern the design of the sculpture’s foundation. More detailed information on how this was analyzed can be found on pages 6-7 of the calculation package included in the appendix of this report.

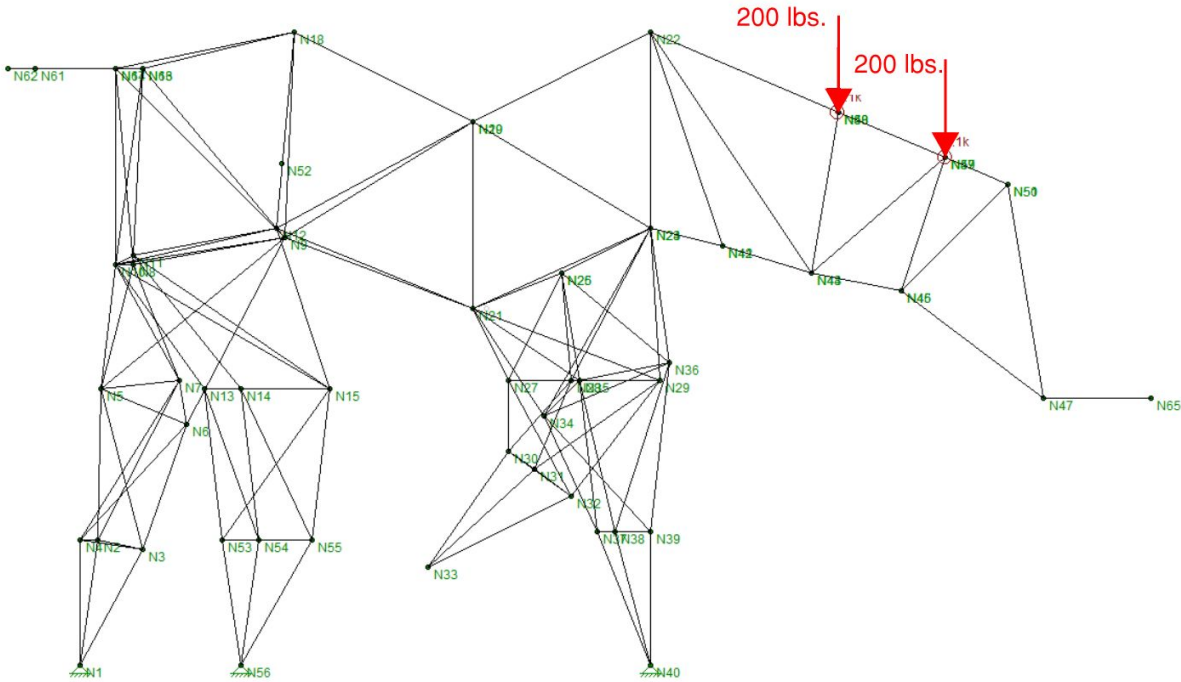

Figure 5: Placement of forces due to people climbing on sculpture

## 2.5 Design of Footing and Anchorage

Once all load cases were analyzed and the reactions occurring at the sculpture supports were determined, the team began designing the footing and anchorage for "Rusty". The first decision the team made was to build two independent pad footings, one large one for the back two legs and one small one for the front leg (See figures 6 and 7). This layout was chosen because of several different reasons, one being that the vertical loads produced by the sculpture were relatively small and could be easily distributed. This also meant that differential settlement would not be an issue because there was no large concentration of vertical load. Another reason for this layout was that the mass of the sculpture varied from front to back meaning that overturning loads at the legs of the sculpture needed to be addressed at the source. The final reason for choosing to build two separate footings was ease of construction since having two separate footings would use fewer materials than one large one. Since no soil report was available for the proposed site, minimum soil bearing values from table 1806.2 in the IBC were used. Each footing was designed to be 12" thick, with the large one being 4.0'x8.0' and the small one being 3.5'x3.5'. These sizes proved to be adequate for spreading the vertical loads from the sculpture without failing the bearing capacity of the soil.

The next design decision was to use cast-in place anchors rather than epoxy anchors. As stated in *Assessing the First Draft* (section 2.1 of this report), epoxy anchors can lose strength if they are not installed correctly. Even at the professional level this issue can occur and since all foundation construction would be done by the students, they chose to proceed with caution and use cast-in-place anchors. Choosing this method of anchorage gave the team confidence that there would be no issues with the anchor bolts since they would be part of a continuous, monolithic system

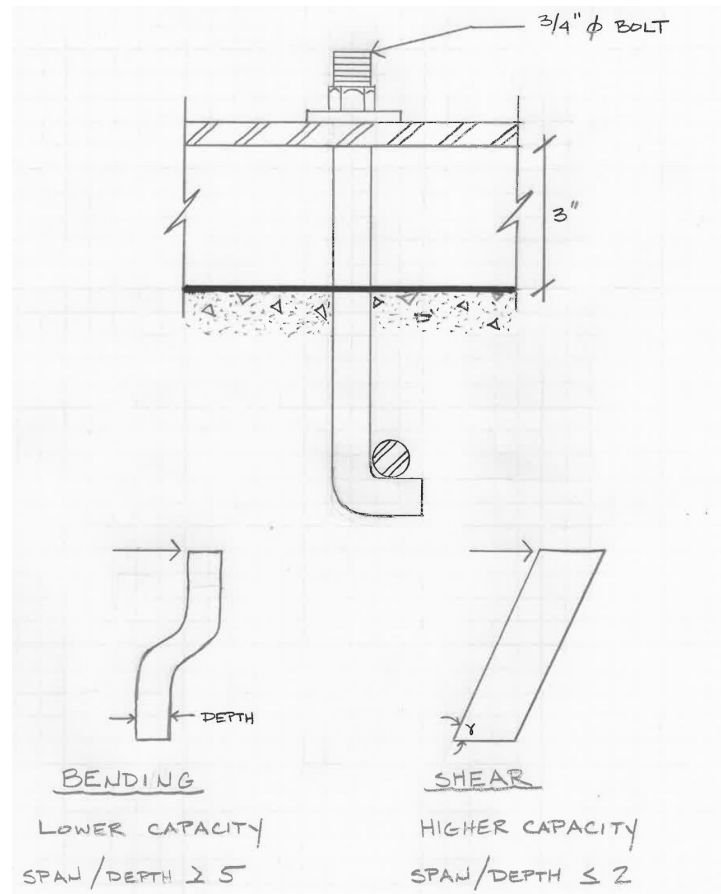

Figure 5.1: Anchor bolt behavior diagram

Another issue the team had to consider when choosing the size of anchor bolts to use was the potential for the bolts to bend (see figure 5.1). The steel plate that the sculpture's legs attach to sat about 3 inches above the top of the footing which meant that the bolts would be protruding at least this much above the concrete surface. Using 0.75" diameter bolts meant that the span to depth ratio for these protruding sections of the bolts would be 4. This meant that when lateral forces were applied to "Rusty", those exposed lengths of bolts would most likely have the tendency to bend. In order to resolve this issue, the team calculated the bending strength of a 0.75" diameter bolt assuming that it was made out of common A36 steel (See page 13 of the calculation package). This calculation showed that the allowable bending stress for the bolt was much higher than the demand bending stress, meaning that the size of bolt chosen was more than adequate for the design loads. Once the strength of the bolt had been checked, a deflection calculation needed to be done in order to determine if the sculpture would shift under the demand lateral loads (See page 13 of the calculation package). It was determined that the deflection of the bolts would be less than an inch

*under the design lateral loads which more than satisfied the design criteria of the project.*

*The last design consideration was the amount of reinforcement needed for each footing to resist cracking. This issue was solved by making sure the selected amount of steel reinforcement met the criteria provided in table 7.6.1.1 in ACI 318-14. More detailed information on how each component of the design was chosen can be found in pages 9-16 of the calculation package included in the appendix of this report.*

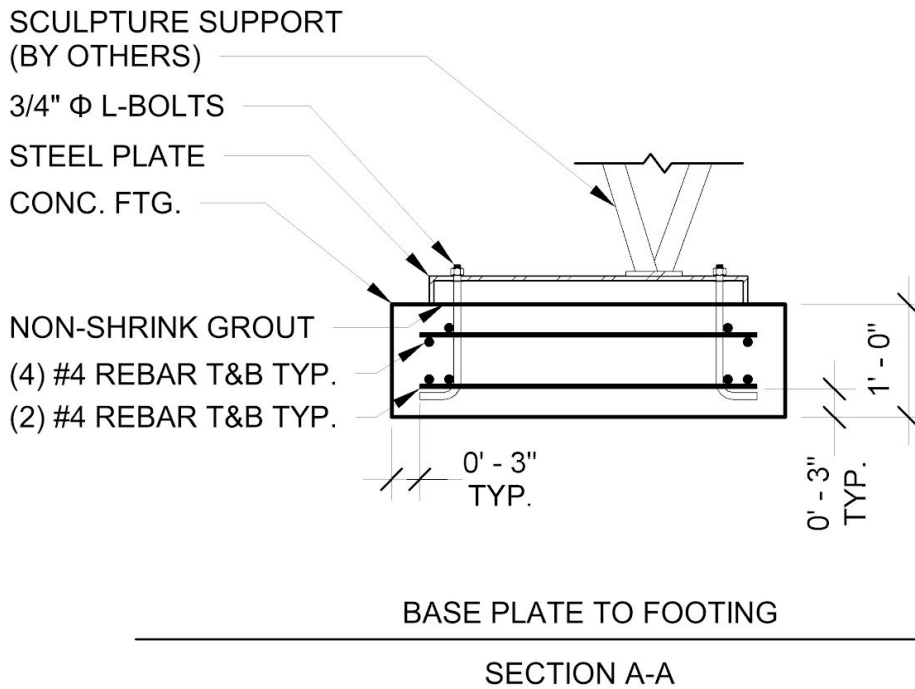
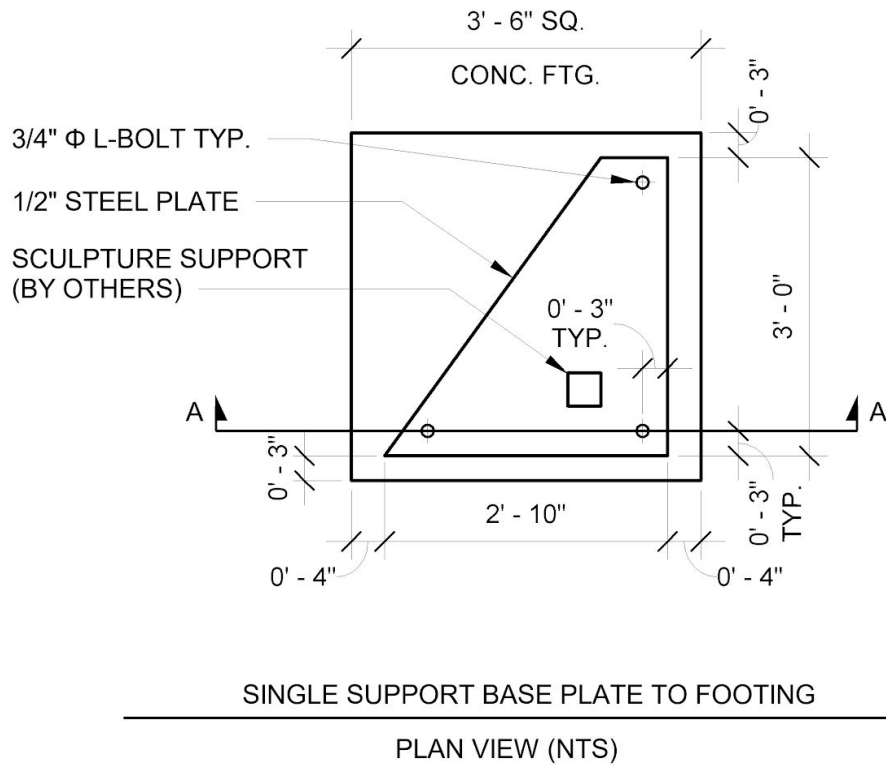

Figure 6: Details for small pad footing

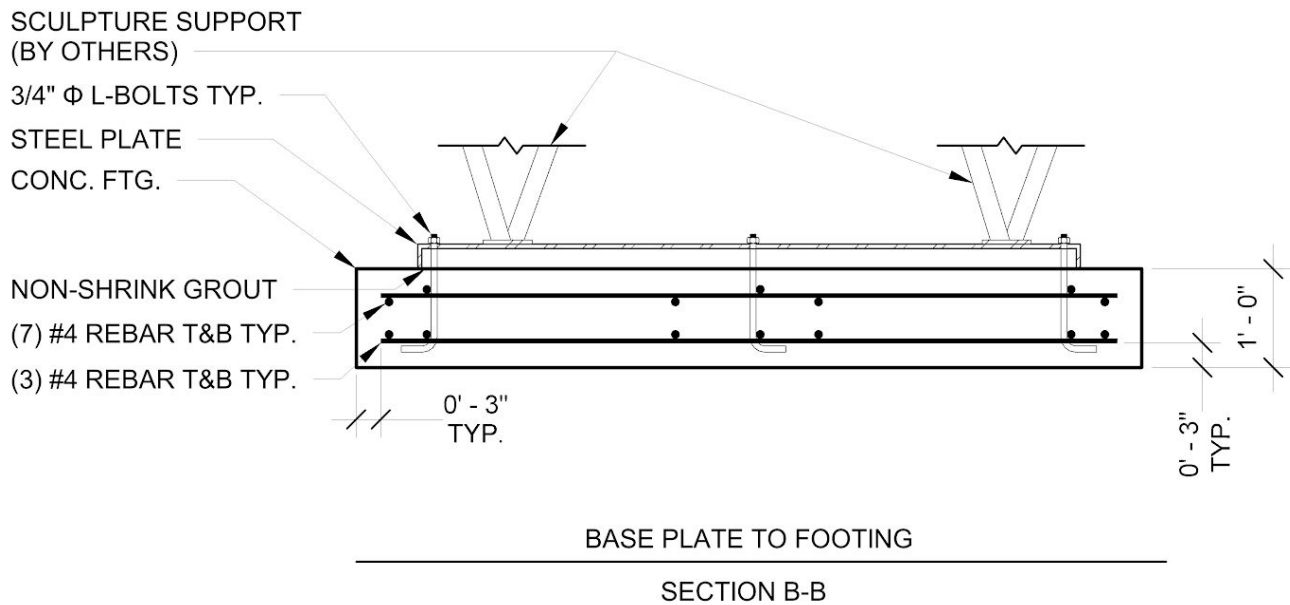
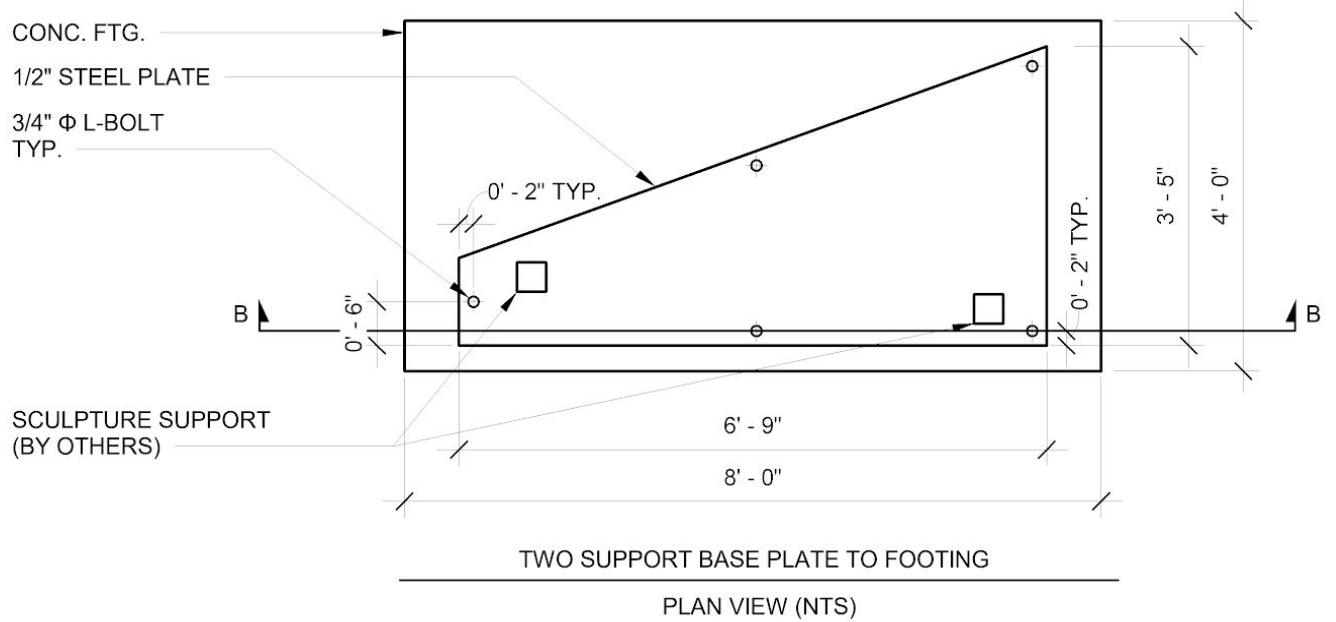

Figure 7: Details for large pad footing

## 2.6 Constructability Considerations

*During the structural design process the team made sure to be constantly considering how the foundation design would be executed in the field. A couple of major considerations were:*

- *Availability of materials such as rebar and concrete*
- *The depth and size of the excavation that would have to be dug by hand*
- *Any pre-existing utility lines beneath the site*
- *Cost of materials and labor*
- *Disposal of excavated materials*
- *Scheduling of others to help erect the sculpture*

*In order to maintain budget, the team chose to excavate by hand rather than pay for digging equipment which meant that the designed dimensions of the foundation needed to be as small as possible. Another constructability consideration was how "Rusty" the mustang would be transported to the site. Carrying the sculpture with help from students was the decided method of delivery which meant that the chosen site location needed to be close to where "Rusty" was stored.*

### 3.0 Final Submittal for Facilities

#### 3.1 Permit Process

*In order to install the temporary sculpture on the Cal Poly Campus, a permit was required along with the approval from campus organizations such as:*

- Cal Poly Facilities*
- The Campus Art Acquisition Committee*
- The College of Architecture and Environmental Design*
- Campus Landscape Services*

*A structural package including the foundation calculations and plans detailed in Section 2.0 was required to be checked by a certified structural engineer in order to ensure the safety of all students, faculty, and public that could potentially interact with the sculpture. The second approval that was required prior to install was a site agreement with the Campus Arts Committee. This process proved to be more time consuming than initially estimated. Due to the students' limited pre-construction experience, the project schedule had to be moved from Fall of 2016 to Spring of 2017.*

##### 3.1.1 Site Approval

*The Fall 2016 project team had been approved by the Campus Arts Committee to install the sculpture in the large planter to the east of the bridge connecting Bldg. 21 to the Construction Management building. However come Spring 2017, new trees and irrigation lines were scattered around the site. Luckily, the planter to the west of the bridge was a mirror image of the east planter and had the same soil type so approval for relocating the site only took a few days as opposed to several weeks.*



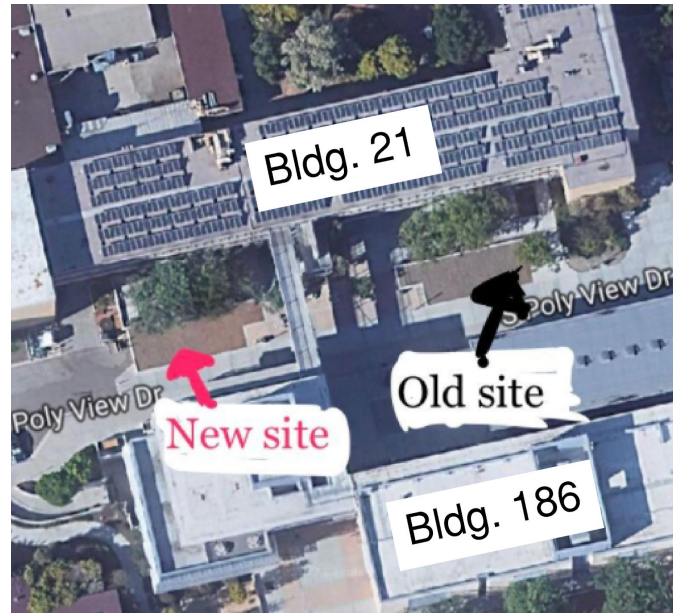

Figure 8: Fall(2016) and Spring(2017) Site Plans

### 3.1.2 Calc Package Submittal

The greatest effort in the approval process was acquiring a permit from the campus construction inspector, Mike Hogan. The required structural package for the permit included calculations for the foundation design, foundation plans, and connection detailing. For greater detail into the structural design refer to Section 2.0. Once submitted to campus facilities, an outside structural engineering firm, Degenkolb, was hired to check the structural package to ensure a safe design. The team submitted the package in week three of Spring quarter but didn't receive approval until week nine. Figure 9 shows the approved permit including all of the conditions that the campus construction inspector required for the project.

Description: PERMIT: MUSTANG SCULPTURE - BLD 21

Enter User:	CYMOST	Schedule Date:	28-APR-2017
Type:	PERMIT	Due Date:	28-APR-2017
Status:	ASSIGNED	Modify Date:	09-JUN-2017
Priority:	5	Start Date:	28-APR-2017
Method:	IN_HOUSE	Req Type:	Service
Crew:	292	PJ Number:	SR0274229
Craft:		Requestor:	TENLEY, JACK, L.
Assigned To:	1083292 HOGAN, MIKE	Telephone:	208/861-1098
Site:	SLO	Mail Code:	
Building:	021	Department:	STUDENT
Bldg Desc:	ENGINEERING WEST	Permit Status:	APPROVED
Floor:		Approval Date:	
Room:			

Conditions/Exceptions

PERMIT: MUSTANG SCULPTURE - BLD 21

LONG TERM TEMPORARY INSTALLATION OF A STUDENT BUILT MUSTANG SCULPTURE.

MY NAME IS JACK TENLEY AND I AM CURRENTLY A 4TH YEAR ARCHITECTURAL ENGINEERING STUDENT AT CAL POLY. I HAVE BEEN WORKING ON A SENIOR PROJECT THAT INVOLVES TEMPORARILY INSTALLING A LARGE STUDENT BUILT STEEL MUSTANG SCULPTURE ON CAMPUS AND WANTED TO APPLY FOR A BUILDING PERMIT. I HAVE ATTACHED THE NECESSARY DETAILS AND CALCULATIONS NEEDED FOR THE FOUNDATION AND ANCHORAGE OF THE SCULPTURE, FEEL FREE TO CONTACT ME OR MY PARTNER, RYAN LLAMAS, IF THERE ARE ANY QUESTIONS.

THANK YOU,  
JACK TENLEY

ARCHITECTURAL ENGINEERING UNDERGRADUATE  
CAL POLY, SAN LUIS OBISPO  
(208)-861-1098

ADDITIONAL CONDITIONS/REQUIREMENTS:

RETAIN A COPY OF THIS BUILDING PERMIT BECAUSE CONTRACTS AND PROCUREMENT MAY REQUEST A COPY BE INCLUDED IN THE PURCHASE ORDER REQUISITION PROCESS.

1. OBTAIN HAZMAT REVIEW RESULTS AND PERFORM WORK ACCORDINGLY. IF HAZARDOUS MATERIAL DO EXIST AND WILL BE DISTURBED, WORK MUST BE PERFORMED BY QUALIFIED PERSONNEL USING APPROPRIATE WORK PRACTICES AND PROTECTIVE EQUIPMENT.

REGARDING THIS JOB NO HAZARDOUS MATERIAL WILL BE DISTURBED

2. ANY MODIFICATION TO EXISTING ELECTRICAL OR ANY NEW ELECTRICAL INSTALLATION REQUIRED FOR PROPER OPERATION OF SYSTEM MUST BE ACCOMPLISHED BY FACILITIES SERVICES ELECTRICIANS VIA A SERVICE REQUEST OR IF A PROJECT, THROUGH THE PROJECT MANAGER ASSIGNED.

3. CONTACT SCOTT LOOSLEY AT 756-2816 TO ASCERTAIN IF ANY UNDERGROUND IRRIGATION WILL BE DISTURBED WITH EXCAVATION.

4. SCULPTURE SHALL BE INSTALLED AS PER APPROVED PLAN.

ADDITIONAL CONDITIONS/REQUIREMENTS REGARDING CONCRETE WORK:

1. CONCRETE SLAB SHALL BE INSTALLED AS PER APPROVED PLAN.

2. STUDENTS SHALL WEAR THE APPROPRIATE PERSONAL PROTECTION EQUIPMENT (PPE) WHILE PERFORMING WORK ON THIS JOB. PPE SHALL INCLUDE LONG PANTS, CLOSED TOED SHOES, EYEPROTECTION, AND LEATHER GLOVES.

3. ANY FORM BOARD CONCRETE STAKES UTILIZED NOT IN THE HORIZONTAL POSITION SHALL BE COVERED WITH CONCRETE STAKE PROTECTIVE CAPS.

Figure 9: Approved Construction Permit

## 4.0 Final Construction

### 4.1 Pre-Construction Planning

*In the year between the library installation and the final semi-permanent campus installation everyone from the original project team had graduated and moved away. Because of this, one of the first tasks the final project team had to do was erect the sculpture in High Bay Lab in order to understand how all the connections lined up, and formulate a plan for the best way to connect the base plates to the foundation. After using the crane in High Bay Lab to erect the sculpture, the project team realized the true scale of the sculpture and decided it best to design each base plate to its own footing (See figure 10).*

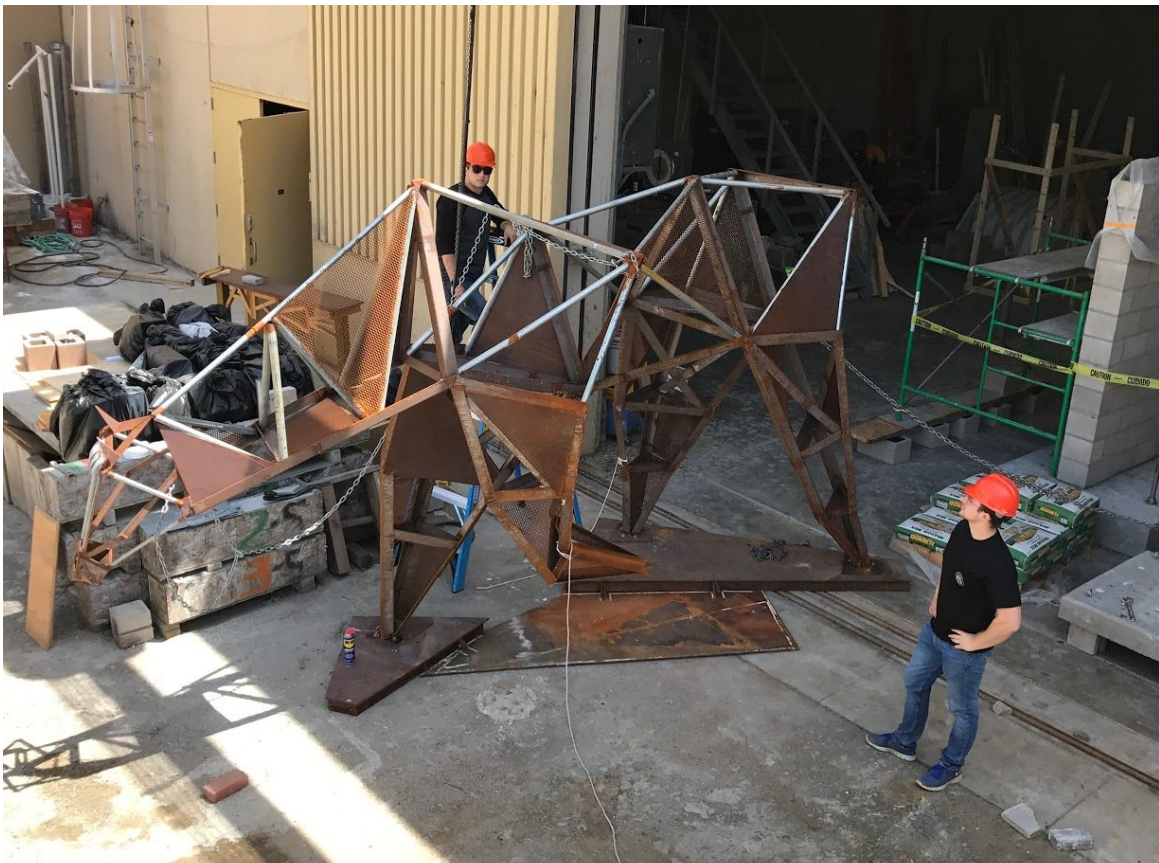
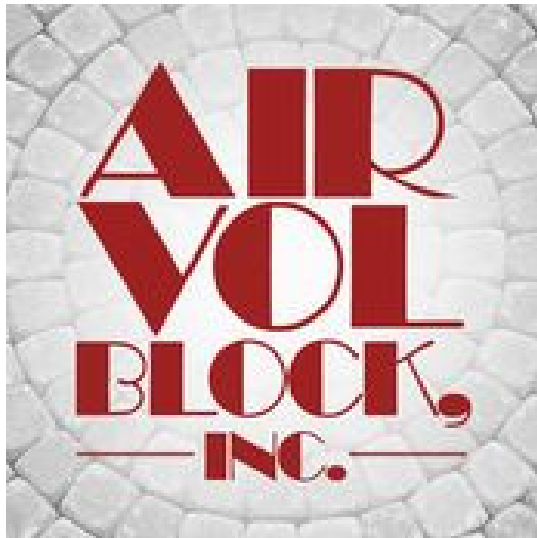

Figure 10: Practice Installation

## 4.2 Material Acquisition

*Due to having a tight schedule, the project team began purchasing and preparing materials while the structural package was out for permitting. The tables in figure 11 (imported from Excel) were used to estimate the volume of concrete and linear feet of rebar needed per footing as well as track the money spent on the entire project. The estimated 1.64 cubic yards that was needed to pour the two footings was generously donated by CalPortland saving the project about \$275. It was estimated that 150 linear feet of #4 rebar would be required to fabricate the two rebar cages for the foundations. All the rebar was purchased from AirVol Block in 4' and 8' lengths for \$75. The only other cost that incurred on the project was a \$25 mag drill rental which was necessary to finish the project on schedule. See references for addresses of the businesses mentioned in this section.*



Mustang Cost

<i>Volume Concrete</i>	<i>w</i>	<i>l</i>	<i>h</i>	<i>ft^3</i>	<i>yd^3</i>
<i>footing #1</i>	4	8	1	32	1.19
<i>footing #2</i>	3.5	3.5	1	12.25	0.45
<i>Total</i>					1.64

<i>Rebar #4</i>	<i>ftg length</i>	<i>ftg width</i>	<i>spacing</i>	<i># of bars</i>	<i>rebar length (ft)</i>
<i>ftg #1</i>	4	8	1.5	10	40
	8	4	1.5	6	48
<i>ftg #2</i>	3.5	3.5	1.5	6	21
	3.5	3.5	1.5	6	21
<i>extra</i>					20
<i>Total</i>					150

<i>Product</i>	<i>Units</i>	<i>\$/unit</i>	<i>\$</i>
<i>Concrete</i>	1.64	0	0
<i>Rebar # 4 (20')</i>	150	0.5	75
<i>Mag Drill Rental</i>	1	25	25
<i>total</i>			\$100.00

*\*Donated*

Figure 11: Price Estimation

### 4.3 Site Preparation

*In terms of impact to the final installation, the site preparation was the step that required the greatest amount of precision. This was due to the sculpture's initial design having a front and back half that were bolted in the center at three locations. Since each half of the sculpture was fastened to separate base plates that each rested on their own footings, a fraction of a degree of rotation or a difference of less than an inch laterally or vertically between each footing would have made the final connection between the two pieces impossible.*

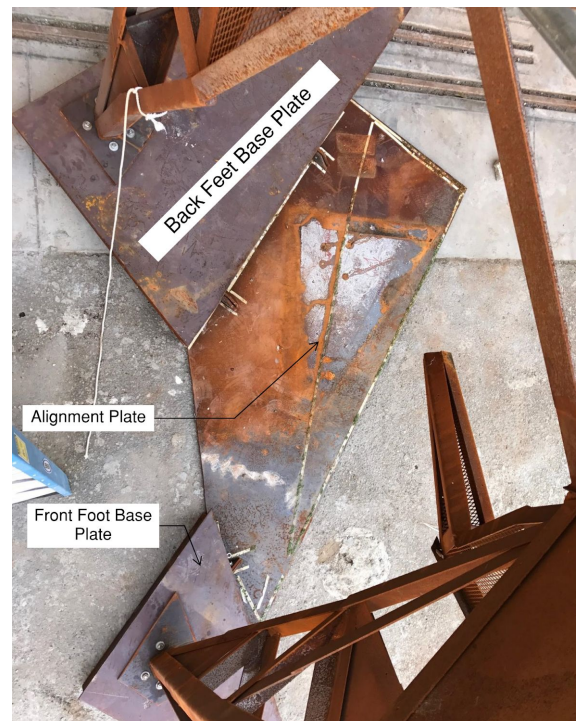

*Figure 12: Sculpture base plate alignment*

*To mitigate these risks, templates of each base plate, footing, and spacer plate were created out of  $\frac{3}{4}$ " cardboard. The base and spacer templates ensured that the final base plate placement would perfectly line up so the two halves of the sculpture could be bolted at the center. The footing templates were also critical to the planning because they were used as guides for the placement of the anchor bolts to make certain they would fit within the border of the plates. All of the templates were brought to the site to help orient the sculpture in relation to the site. Once an orientation was agreed upon between the project team, senior project advisor, and Campus Art Committee the footings were staked out.*



Figure 13: Base and Spacer Plate Templates Oriented on Site with Construction Fence

*The last step in the site preparation process after staking out the footings was to erect construction fence around the perimeter to keep people away from potential injury. Two 2-cubic yards tote bags were placed on wooden pallets so the excavated soil could be easily forklifted offsite at the conclusion of the project.*

#### 4.4 Foundation Construction

*Once the site was fenced off and the permit was officially approved by all parties, construction began. The project team took on new roles as laborers and self-performed the construction both to save costs and to live up to Cal Poly's learn by doing motto. It took two days to excavate the 1.62 cubic yards of soil and clear the holes of loose debris. The rebar cage for each footing was built per the structural design. Once the top and bottom layers of each foundation were tied they were placed on top of the base plate template to mark the location where the anchor bolts were to be tied (See figure 15 below). Each rebar cage was then transported to the site and hung from 2x4s that span the excavation in order to achieve the cover specified by the design. The anchor bolts were bolted to the 2x4s hanging over the excavation for better stability during the concrete pour as well as to ensure the required depth into the foundation (See figure 15 below). Within four days from the erection of the construction fence, CalPortland was*

onsite pouring the concrete for the footings (See figure 16 below). In the middle of each foundation pour a concrete cylinder was poured to be tested for adequate strength before the final sculpture installation could occur (See figure 17 below).

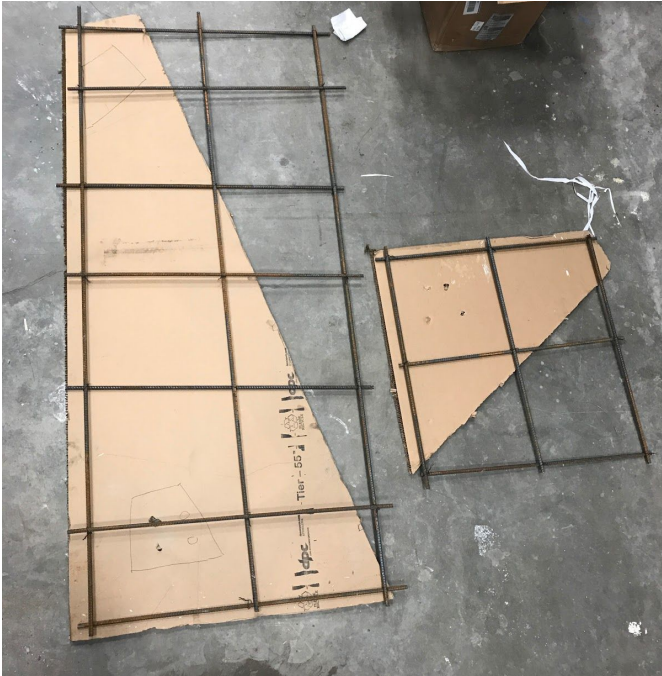

Figure 14: Constructing the Rebar Cages



Figure 15: Rebar Cage and Anchor Bolt Positioned in Excavation





Figure 16: Concrete Pour



Figure 17: Concrete Cylinders for Compression Tests

#### 4.5 Rusty Installation

*After five days of curing, the cylinders were tested to find that the concrete had gained adequate strength to support the sculpture. The formwork was removed and the base plates were fork lifted over to the site. Using the base plate templates, the as-built location of each anchor bolt was accurately measured and marked on each steel base plate. A mag drill was used to drill five holes in the large back base plate and three holes in the smaller front plate (See figure 18).*



Figure 18: Mag Drilling Hole in Base Plate

*Due to the careful planning, only two of the holes had to be slotted to fit the anchor bolts through (See figure 19).*



Figure 19: Base Plate on Foundation

Once the base plates were fastened into place the sculpture could be lifted into place. The crane in High Bay Lab was used to lift the hind legs into a position that a forklift could grab the piece and carry it down to the site. After the hind legs were attached to its base plate the same process was repeated for the front piece (See figure 20). Just as planned the two pieces perfectly met in the middle and were bolted together with ease (See figure 21).



Figure 20: Hind Legs Attached, Front Half Forklifted to site



Figure 21: Fully Erected Sculpture

## 5.0 Reflection

*Upon completing the final installation of "Rusty" the Mustang, the team had gained a better insight into the building industry. Although this project was done on a small scale, the steps needed to complete it reflected the process necessary for almost all real-world construction jobs. It started with Jack and Ryan learning how to formulate a well-developed and concise calculation package that could be understood and reviewed by other engineers and construction inspectors. The team then had the opportunity to work with these consultants in order to move towards receiving a building permit. It was during this process that they learned just how time consuming the permitting process was but also how important it is to ensure a safe design. After receiving their permit, Jack and Ryan got to experience first hand the construction and coordination needed to complete their project while also maintaining a schedule. Although each one of these steps proved to be challenging in their own way, the team was able to conquer these challenges and gain an appreciation for the construction industry as a whole. Overall, installing "Rusty" the Mustang on Cal Poly's campus served as a true "Learn by Doing" experience, and Jack and Ryan hope that others will see it as a physical representation of this motto.*



Figure 22: "Rusty" the Mustang sculpture 9 months after construction (Jack Tenley in front)

## 5.0 Works Cited

- [1] Petrarca, Nicholas J, et al. "The Built ENVIRONMENT." *DigitalCommons@CalPoly*, June 2016, [digitalcommons.calpoly.edu/arcesp/17/](http://digitalcommons.calpoly.edu/arcesp/17/).
- [2] Gibbons, Natalie, and Jordan Gates. "The Mustang Sculpture." *DigitalCommons@CalPoly*, Dec. 2016, [digitalcommons.calpoly.edu/arcesp/27/](http://digitalcommons.calpoly.edu/arcesp/27/).
- [3] Air-Vol Block, 1 Suburban Rd, San Luis Obispo, CA 93401
- [4] Cal Portland, 219 Tank Farm Rd, San Luis Obispo, CA 93401

## 6.0 Appendix

Use to request authorization for Department-directed jobs



**CAL POLY**

SAN LUIS OBISPO

**Facilities Customer  
and Business Services**

**BUILDING PERMIT  
APPLICATION FORM**

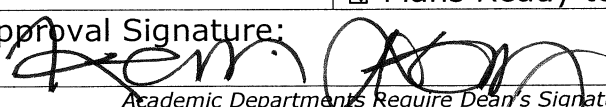
Send completed permit application to:  
Email: [facilities-CBS@calpoly.edu](mailto:facilities-CBS@calpoly.edu)  
Fax: 756-6114 Attn: Facilities Help Center

Applicant's Name: Jack Tenley, Ryan Llamas <i>(Applicant will be the primary contact for this project)</i>		Today's Date: 04/24/17	
Phone Number: (208)-861-1098 (JACK)		Department: ARCHITECTURAL ENGINEERING	
Alternate Phone Number: (714)-767-8951 (RYAN)		Email Address: jtenley@calpoly.edu, rllamas@calpoly.edu	
Optional: Names and Phone numbers of other involved parties <i>(Supervisor, Dean, Advisor etc.)</i>		CRAIG BALTIMORE (ADVISOR) cbaltimo@calpoly.edu, (805)-756-6384	
Project Name: MUSTANG SCULPTURE		Bldg. Name: between building 21 and 186, in planters	
Who is doing the work? <i>(Check all that apply)</i>		Room #: N/A	
<input type="checkbox"/> Contractor	<input checked="" type="checkbox"/> Student Project	<input type="checkbox"/> Other <i>(Explain)</i>	
<input type="checkbox"/> Department Labor			
Source of Funding:		Estimated Cost/Budget: \$710	
Description of Project: Long-term temporary installation of a student built mustang sculpture			
** <b>Email supporting documents</b> such as scope, plans, specifications, location, etc. to: <a href="mailto:facilities-CBS@calpoly.edu">facilities-CBS@calpoly.edu</a> <b>and</b> Mike Hogan at <a href="mailto:mhogan@calpoly.edu">mhogan@calpoly.edu</a>			
Status of Project:		<input type="checkbox"/> Proposal <i>(We can only review the concept, not issue a permit)</i>	
		<input checked="" type="checkbox"/> Plans Ready to Review	
		<input type="checkbox"/> Under Construction <i>(oops!)</i>	
Approval Signature: 		Kevin Dong	
<i>(Academic Departments Require Dean's Signature Non-Academic Departments Require Division or Department Head Signature)</i>		<i>(Please Print Name)</i>	
Project Number:		SR _____	
Time Window:			
REV 9/14			
Return Application Form to Facilities Customer and Business Services			
		FAC-10A	



<b><i>Table of Contents</i></b>	<b><i>Page</i></b>
<i>Project Proposal</i> .....	<i>1</i>
<i>RISA Model</i> .....	<i>2-3</i>
<i>Dead Load Takeoff</i> .....	<i>4</i>
<i>Lateral Loads</i> .....	<i>5-8</i>
<i>Foundation Design</i> .....	<i>9-17</i>
<i>Renderings</i> .....	<i>18</i>

<b><i>Table of Figures</i></b>	<b><i>Page</i></b>
<i>Figure 1: Site Location</i> .....	<i>1</i>
<i>Figure 2: Elevation of Sculpture</i> .....	<i>2</i>
<i>Figure 3: Plan view of sculpture</i> .....	<i>3</i>
<i>Figure 4: Elevation of Sculpture and Area Calculation</i> .....	<i>3</i>
<i>Figure 5: Elevation of Human Loading on Sculpture</i> .....	<i>7</i>
<i>Figure 6: Plan View of Human Loading on Sculpture</i> .....	<i>7</i>
<i>Figure 7: Plan View of Wind Loading on Sculpture</i> .....	<i>8</i>
<i>Figure 8: Plan View of Seismic Loading on Sculpture</i> .....	<i>8</i>
<i>Figure 9: West Elevation Rendering</i> .....	<i>17</i>
<i>Figure 10: South Elevation Rendering</i> .....	<i>17</i>

---

### **Proposal Summary:**

The following proposal includes the details and calculations for the base plate connection and foundation needed for the long-term temporary installation of the mustang sculpture in the large planter between building 21 and building 187. Currently the sculpture has three supports, two back legs and one front leg. The two back legs of the sculpture will bear on a 4'x8'x1' deep concrete footing while the front leg will bear on a 3'-6" square x 12" deep concrete footing. The footings are reinforced with #4 bars at the top and bottom.  $\frac{3}{4}$ "  $\varnothing$  threaded L-bolts will be placed in each footing to secure a steel plate at the base of each support to the footing. Calculations and details for the concrete footings appear in this package, as well as renderings of the final product.

Calculations appear in the order as follows:

- RISA (structural analysis software) model input: sculpture with dimensions and dead loads
- Dead load takeoff
- Seismic loads per ASCE 7-10
- Wind loads per ASCE 7-10
- RISA analysis output: reactions at supports and load case summary
- Foundation design
- Steel base plate check
- Foundation Plans/Sections
- Finished project renderings

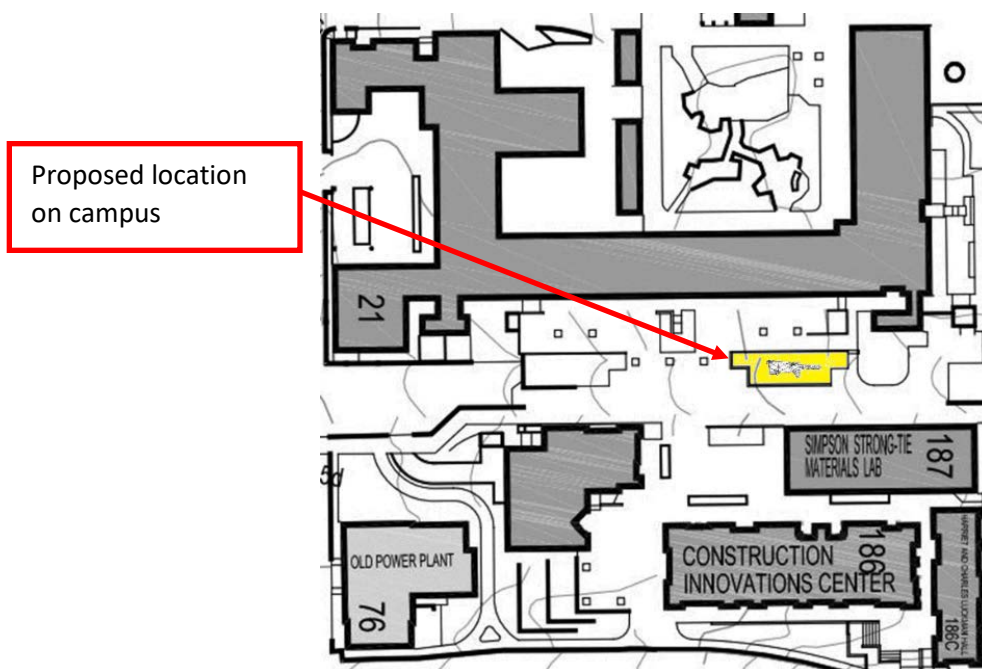

Figure 1: Site location

**Dead Load Takeoff**

The sculpture was constructed using recycled steel and includes several reoccurring steel components such as pipes, plates, and angles. The weight and thickness for each steel component was taken from the AISC Steel Construction Manual, 14<sup>th</sup> Edition. The average length for each component was measured and recorded for the dead load estimation. A 43 pound miscellaneous load is included in the dead load takeoff to account for any slight inaccuracies during the weight estimation of the sculpture.

<b>Dead Load Takeoff</b>						
Material	Thickness (in)	Average Length (in)	Weight	# of Members	Total Weight	Reference
Pipe 1 1/2" Std.	0.145	48	2.72 lb/ft	24	261 lb	AISC Tbl. 1-14
Pipe 1" Std.	0.133	24	1.68 lb/ft	6	20 lb	AISC Tbl. 1-14
L 2 1/2" x 2 1/2" x 1/4"	0.250	30	4.10 lb/ft	30	308 lb	AISC Tbl. 1-7
Plate 2 1/2"	0.250	24	490 lb/ft <sup>3</sup>	16	68 lb	AISC Tbl. 17-12
Total Weight of Sculpture =	657 lb					
Misc. =	43 lb					
<b>Design Weight to be Used =</b>	<b>700 lb</b>					

The dead load of the sculpture was analyzed using RISA (structural analysis software) to make sure that the weight of the sculpture was close to what was estimated in the dead load takeoff. The negative values represent loads in tension while the positive values represent loads in compression. After summing the loads in the Y-direction, the sculpture was found to weigh 601 pounds, which means the estimated weight from the dead load takeoff is conservative by about 100 pounds.

<i>Dead Load Only</i>			
<b>Joint Label</b>	<b>X (kips)</b>	<b>Y (kips)</b>	<b>Z (kips)</b>
N1	0.034	0.525	-0.273
N56	0.110	-0.489	0.184
N40	-0.145	0.565	0.090

**Horse Dimensions:**

The mustang sculpture was modeled in RISA (structural analysis software) using actual dimensions taken in the field. Each material used in the real sculpture was modeled in RISA so a correct center of gravity calculation could be made using the center of gravity function. The model was then imported into Bluebeam (pdf editing software) and scaled appropriately so additional measurements could be taken. The element in bold was measured as 5'-4" in the field which proves that the model was scaled correctly.

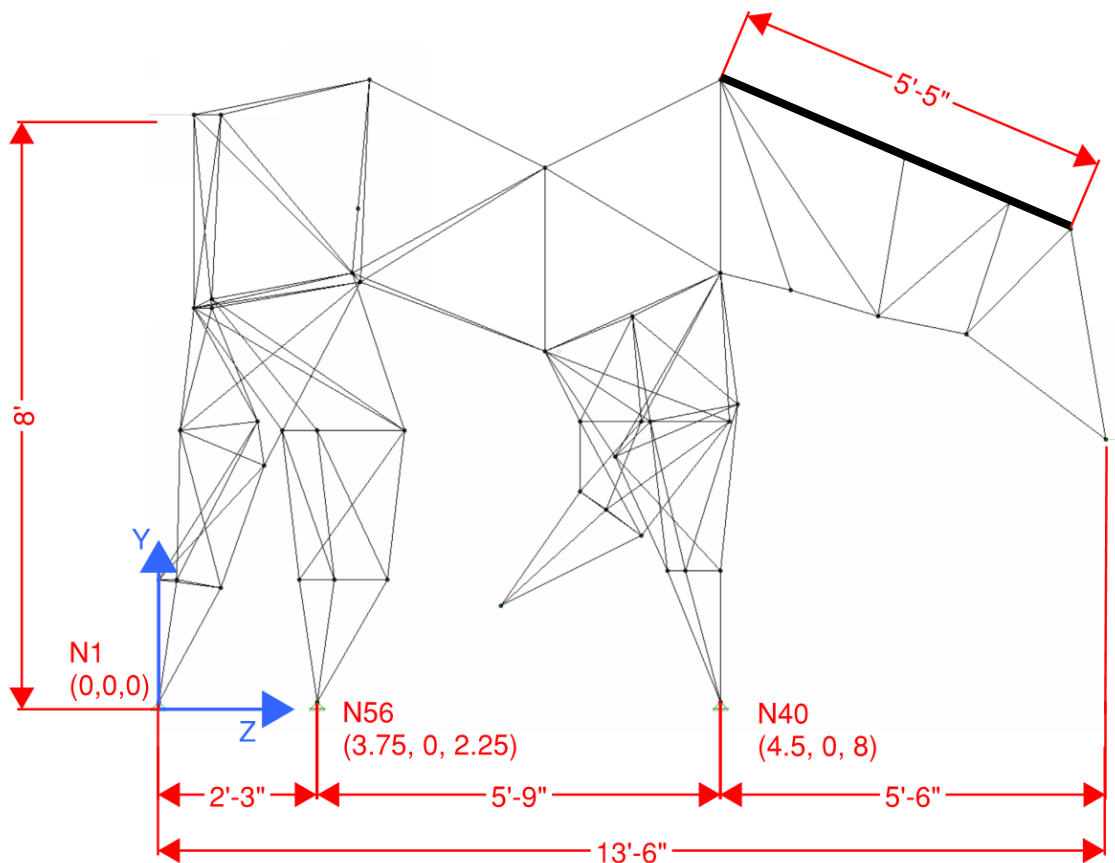

Figure 2: Elevation View of Sculpture with Dimensions

### **Area Calculation**

After scaling the model, the center of geometry and the area of the elevation of the sculpture was recorded using the area measurement function in Bluebeam. Since the sculpture is assumed to be a rigid structure, the wind load was calculated using this area and placed at the geometric center.

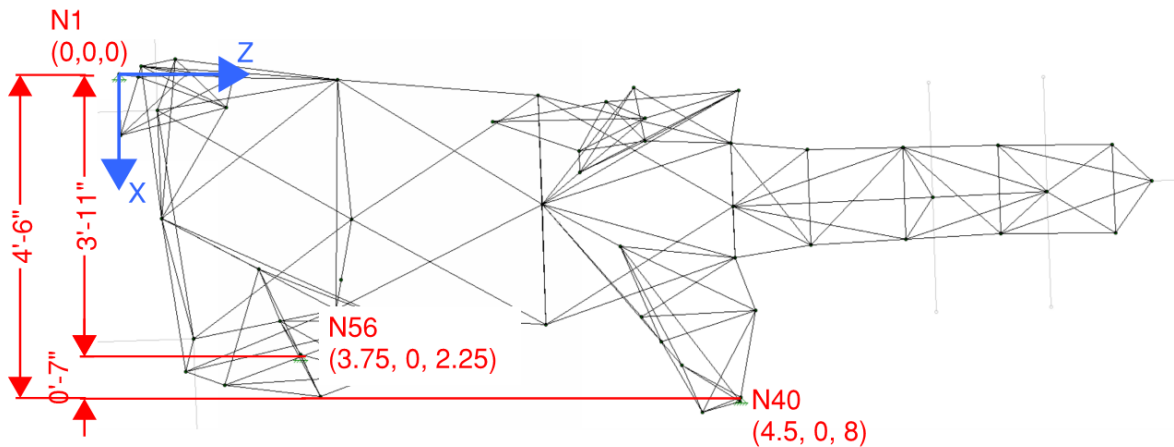

Figure 3: Elevation of Sculpture and Area Calculation

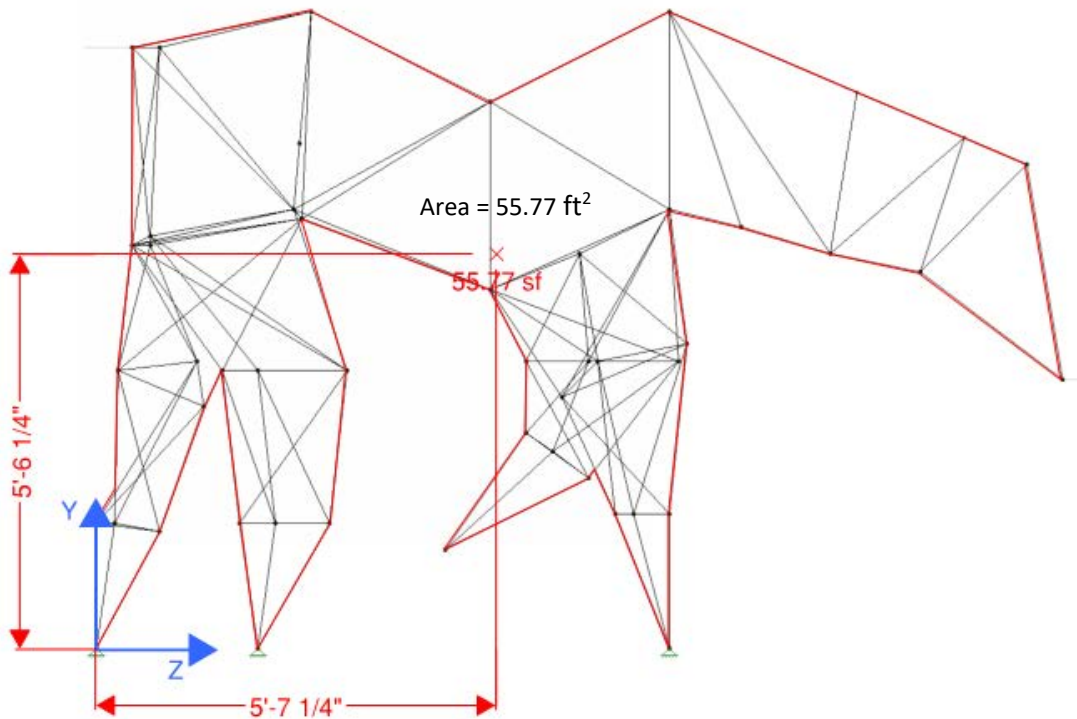

Figure 4: Area Calculation of Sculpture Elevation

**Seismic Loading per ASCE 7-10**

		Units	Reference
Design Seismic Load	$F_p = [0.4 \cdot a_p \cdot S_{ds} \cdot W_p / (R_p / I_p)] \cdot [1 + 2 \cdot (z/h)]$	lb	Eqn. 13.3-1
Upper Limit	$F_{pmax} = 1.6 \cdot S_{ds} \cdot I_p \cdot W_p$	lb	Eqn. 13.3-2
Lower Limit	$F_{pmin} = 0.3 \cdot S_{ds} \cdot I_p \cdot W_p$	lb	Eqn. 13.3-3
$S_{ds} =$	0.790		USGS Seismic Design Maps
$a_p =$	2.5		Tbl. 13.5-1
$W_p =$	700	lb	Dead Load Takeoff
$R_p =$	2.5		Tbl. 13.5-1
$I_p =$	1.0		Section 13.1.3
$z =$	0	ft	Height from base to connection
$h_{avg} =$	8	ft	See Elevations
$F_p$	221	lb	
$F_{pmax}$	885	lb	
$F_{pmin}$	166	lb	
<b>**All equations and references in accordance with chapter 13 of ASCE 7-10</b>			

**Wind Loading per ASCE 7-10**

		Units	Reference
Design Wind Load	$F = q_z \cdot G \cdot C_f \cdot A_f$	lb	Eqn. 29.5-1
Velocity Pressure, $q_z$	$q_z = 0.00256 \cdot K_z \cdot K_{zt} \cdot K_d \cdot V^2$	lb/ft <sup>2</sup>	Eqn. 29.3-1
Exposure Category	B		Section 26.7
Velocity Pressure Exposure Coefficient, $K_z$	0.57		Tbl. 29.3-1
Topographic Factor, $K_{zt}$	1.0		Section 26.8
Directionality Factor, $K_d$	0.85		Tbl. 26.6-1
Gust-Effect Factor, $G$	0.85		Section 26.9.1
Force Coefficient	1.8		Figure 29.5-2
Basic Wind Speed	110	mph	Figure 26.5-1
Projected Area Normal to Wind, $A_f$	55.8	ft <sup>2</sup>	
$q_z =$	15.0	psf	
$F =$	1281	lb	
<b>**Structure defined as lattice framework category in ASCE 7-10, chapter 29</b>			

**Load Case Summary:**

Wind and seismic loads were placed on the computer model of the sculpture in RISA (structural modeling software) and the reactions at each support were recorded. The dead load of the structure was also taken into account as well. All load cases are ASD.

Human loads due to people hanging on the sculpture were also analyzed by placing two 200-pound point loads on the sculpture where the moment would be maximized, however the load case that includes these loads did not govern. (See page 7-8 for diagram of load placement)

- 1) D
- 2) D + L
- 3) D + (Lr or S or R)
- 4) D + 0.75L + 0.75(Lr or S or R)
- 5) D + (0.6W or 0.7E)
- 6a) D + 0.75L + 0.75(0.6W) + 0.75(Lr or S or R)
- 6b) D + 0.75L + 0.75(0.7E) + 0.75S
- 7) 0.6D + 0.6W **Governing Load Case**
- 8) 0.6D + 0.7E **Governing Load Case**

Wind loading governs in East/West direction (See page 5)

Seismic loading governs in North/South direction (See page 5)

**\*\*Note:** Governing load cases shown below are Allowable Stress Design load combinations. Reactions represent resultant loads on joints at the foundation.

**\*\*\*Note:** Negative forces are in tension and positive forces are in compression.

0.6D + 0.6W			
Joint Label	X (kips)	Y (kips)	Z (kips)
N1	-0.124	-0.915	0.505
N56	-0.384	1.708	-0.565
N40	-0.769	0.289	0.06

0.6D + 0.7E			
Joint Label	X (kips)	Y (kips)	Z (kips)
N1	0.043	0.832	-0.445
N56	0.149	-0.588	0.214
N40	-0.192	0.838	0.076

Location of Human Loading

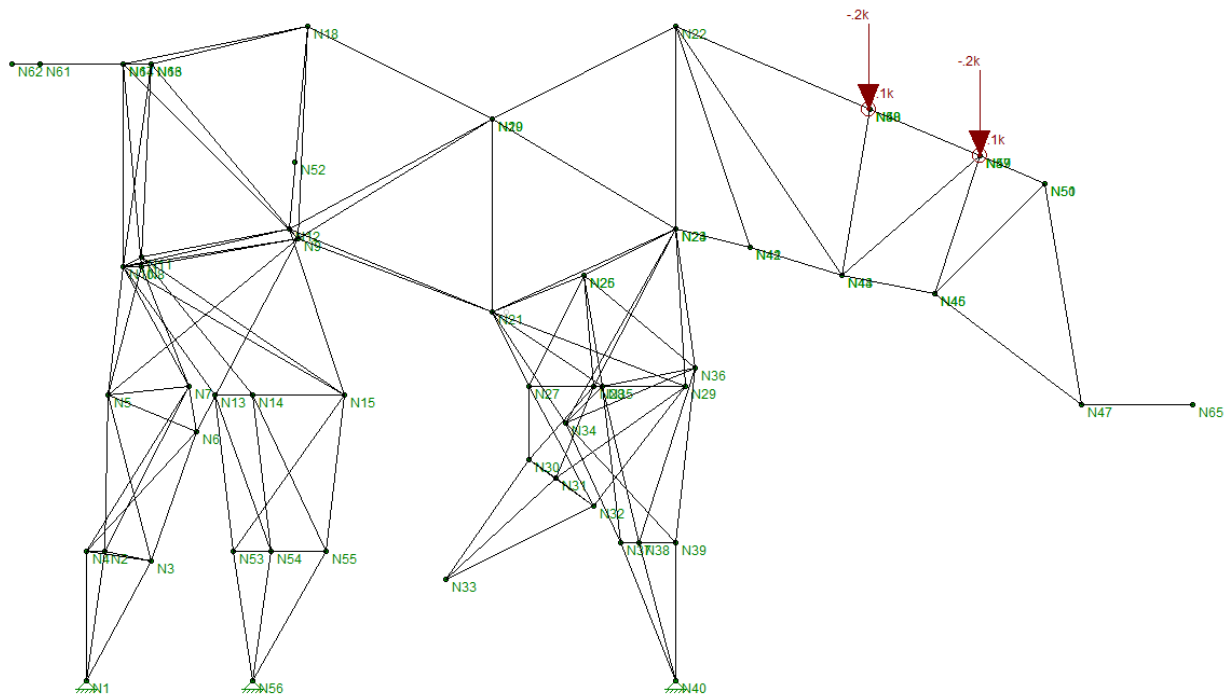

Figure 5: Elevation of Human Loading on Sculpture

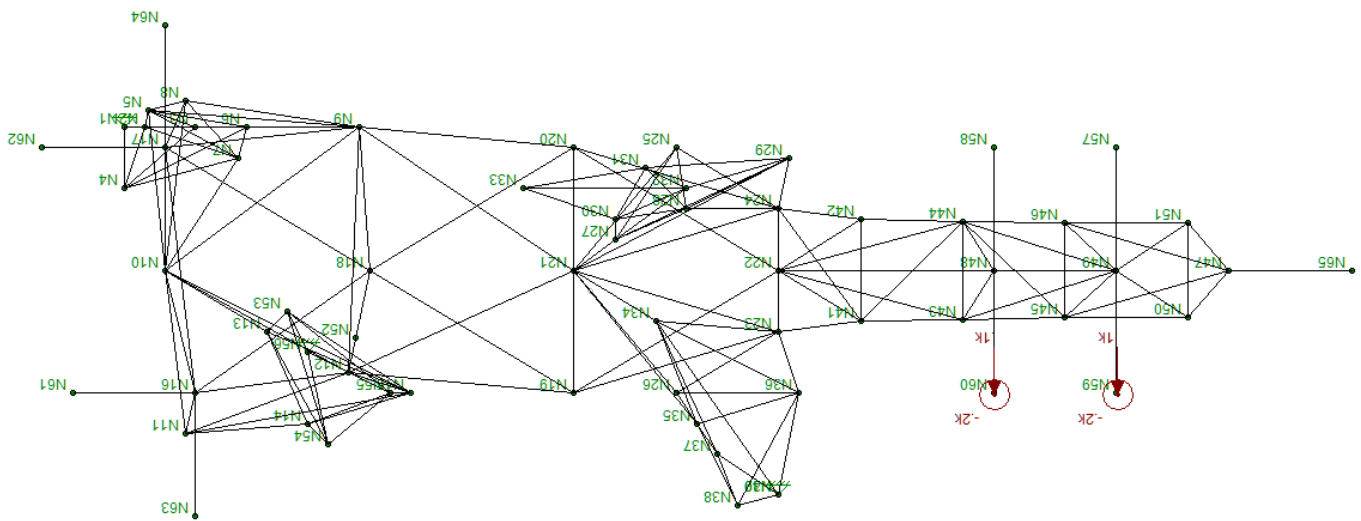
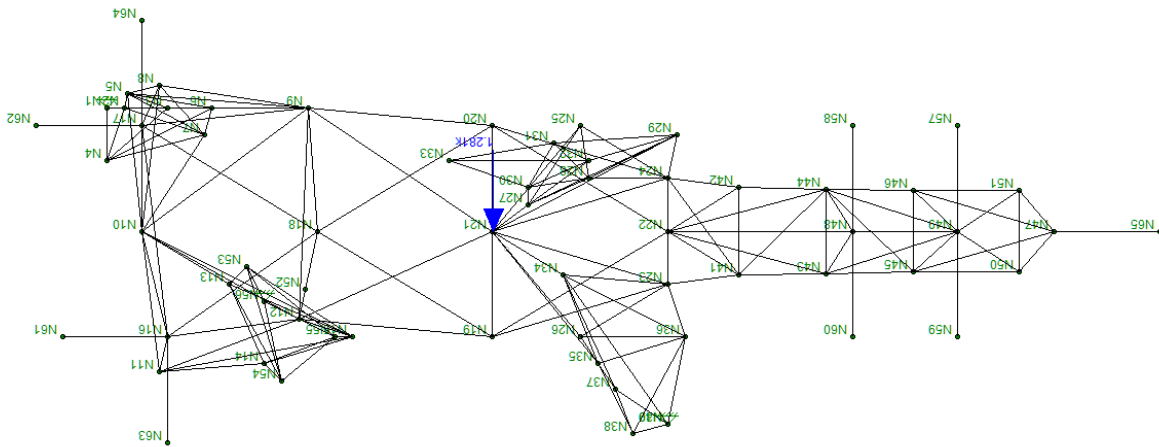

Figure 6: Plan View of Human Loading on Sculpture



*Location of Wind Load at Center of Geometry*



*Figure 7: Plan View of Wind Loading on Sculpture*

*Location of Seismic Load at Center of Mass*

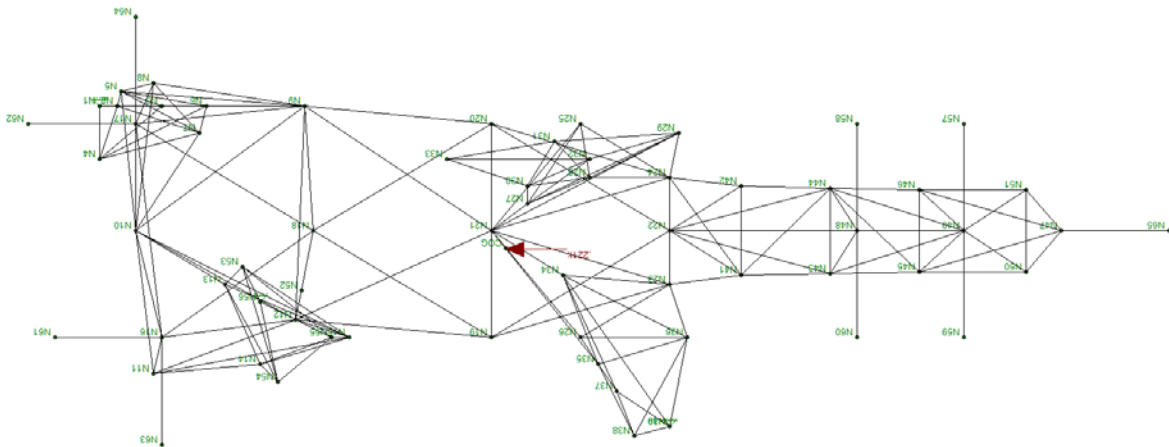

*Figure 8: Plan View of Seismic Loading on Sculpture*

**Foundation Design:**

Two pad footings are to be used for the foundation in order to prevent uplift, one supporting the back two legs of the sculpture in bearing and uplift, and one supporting the front leg of the sculpture in bearing and uplift.

**Factored Design Loads:**

Maximum Bearing Load = 1708 lb [see page 6]

Maximum Uplift Load = 915 lb [see page 6]

**Rectangular Pad Footing Design:**

CHECK WT. OF FOOTING TO RESIST UPLIFT

TRY 8' LONG x 4' WIDE x 1' THICK CONC. FTG.

LOAD CASE:  $0.6D + 0.6W$

$T = 0.915^k$  UPLIFT

$C = 1.708^k$  BEARING

NOTE: UPLIFT CAUSES THE SCULPTURE TO TOPPLE OVER SO WE WILL TAKE THIS FORCE INTO ACCOUNT FOR THE OVERTURNING MOMENT

$$\text{FTG. WT.} = 150 \text{ pcf} (1') (8') (4') \\ = \underline{4800 \#}$$

$$4.8^k > 0.915^k \quad \text{O.K.}$$

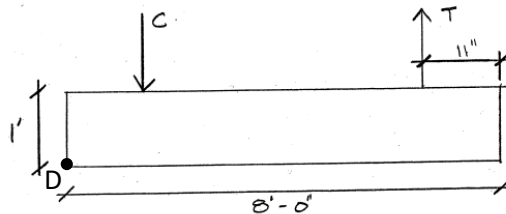

FIND OVERTURNING AND RESISTING MOMENTS

MOMENTS ARE SUMMED ABOUT POINT D

$$M_{OT} = 0.915^k (8' - \frac{11"}{12}) = \underline{6.48^k \cdot \text{FT}}$$

$$M_R = 4.8^k (4') = \underline{19.20^k \cdot \text{FT}} > 6.48^k \cdot \text{FT} \quad \text{O.K.}$$

\* WT. OF FTG. CAN RESIST OVERTURNING

FACTOR OF SAFETY:

$$F.S. = \frac{19.20^k \cdot \text{FT.}}{6.48^k \cdot \text{FT.}} = 3.0$$

CHECK BEARING PRESSURE ON SOIL

$$x = \frac{19.2 \text{ k}\cdot\text{ft} - 6.48 \text{ k}\cdot\text{ft}}{1.8 \text{ k}} = 2.65' \quad l = 3(x) = 8'$$

$$\text{SOIL BEARING, } f_{\text{BEAR.}} = \frac{4.8 \text{ k} + 1.71 \text{ k}}{8' (4')} = 0.203 \text{ ksf}$$

$$f_1 = 0.203 \text{ ksf} \quad f_2 = \left( \frac{8' - 11''/12''}{8'} \right) 0.203 \text{ ksf} = 0.180 \text{ ksf}$$

$$f_{\text{BEAR. AVG.}} = (0.203 \text{ ksf} + 0.180 \text{ ksf}) / 2 = 0.192 \text{ ksf}$$

$$\text{ALLOWABLE BEARING} = 1.5 \text{ ksf} > 0.192 \text{ ksf} \quad \text{o.k. [IBC Tab. 1806.2]}$$

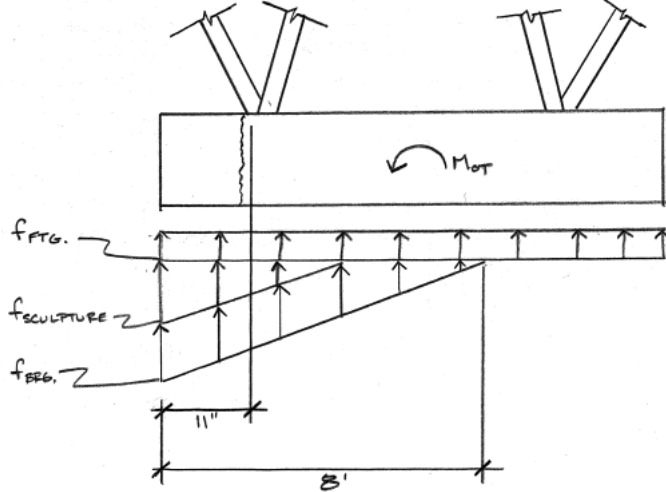

CHECK FTG. FOR SHEAR

$$V_u = 0.192 \text{ ksf} (4' \times 11''/12) = 0.704 \text{ k}$$

$$V_c = 2 \lambda \sqrt{f'_c} b_w d \quad [\text{ACI 318 Eqn. 22.5.5.1}]$$

$$V_c = 2 (1) \sqrt{2500 \text{ psi}} (4' \times 12'') (12' - 3' - 3'')$$

$$V_c = 28.8 \text{ k} > 0.704 \text{ k} \quad \text{o.k.}$$

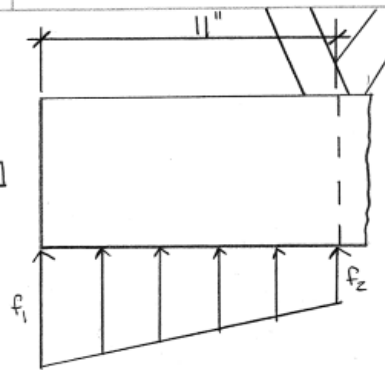

CHECK SHEAR BTWN. SUPPORTS

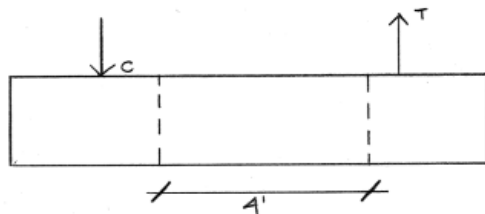

$$C = 1.71 \text{ k} \quad * \text{ WILL CAUSE THE MOST SHEAR FORCE}$$

$$V_c = 2 \lambda \sqrt{f'_c} b_w d \quad [\text{ACI 318 Eqn. 22.5.5.1}]$$

$$V_c = 2 (1) \sqrt{2500 \text{ psi}} (4' \times 12'') (12' - 3' - 3'')$$

$$V_c = 28.8 \text{ k} > 1.71 \text{ k} \quad \text{OK.}$$

FIND REINFORCEMENT NEEDED FOR BENDING  
DESIGN FOR  $M_{OT}$  EVEN THOUGH  $M_R$  IS LARGER

$$M_u = \rho b d^2 f_y \left(1 - \frac{0.59 \rho f_y}{f'_c}\right)$$

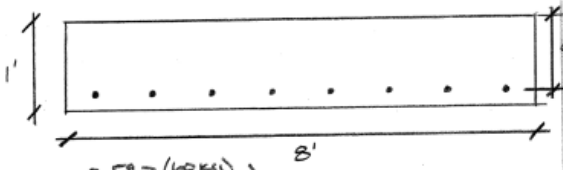
$$f'_c = 2500 \text{ psi}$$

$$6.48 \text{ k}\cdot\text{ft} = \rho (8' \times 12'') (9'')^2 (60 \text{ ksi}) \left(1 - \frac{0.59 \rho (60 \text{ ksi})}{25 \text{ ksi}}\right)$$

$$\rho = 0.000167$$

$$A_s = \rho b d$$

$$A_s = 0.000167 (8' \times 12'') (9'') = 0.144 \text{ in}^2 \text{ REQ'D}$$

$$A_{smin} = 0.0018 b d$$

$$A_{smin} = 0.0018 (8' \times 12'') (9'') = 1.556 \text{ in}^2 \text{ REQ'D} \leftarrow \text{GOVERNS}$$

TRY (8) #4  $\sim A_s = 1.6 \text{ in}^2 > 1.556 \text{ in}^2$  O.K.

USE (4) #4 T # B

Square Pad Footing Design:

Footing will act as a "dead man" under front leg.

Assume a footing depth of 12"

**Bearing Check:**

$$P/\bar{\delta}_{conc.} = 1708 \text{ lb}/150 \text{ pcf} = 11.4 \text{ ft}^3$$

$$11.4 \text{ ft}^3/1 \text{ ft} = 11.4 \text{ ft}^2$$

Use 3.5' Sq. Concrete Footing

$$P/A = 1708 \text{ lb}/(3.5 \text{ ft} \times 3.5 \text{ ft}) = 139.4 \text{ psf} < 1500 \text{ psf} \quad \text{O.K.} \quad [\text{IBC Tbl. 1806.2}]$$

**Uplift Check:**

$$(3.5 \text{ ft})^2 \times 1 \text{ ft} \times 150 \text{ pcf} = 1837.5 \text{ lb} > 915 \text{ lb} \quad \text{O.K.}$$

**Addition of Rebar to Meet Code Minimum:**

$$A_{smin} = 0.0018 \times A_g$$

$$= 0.0018 \times 12'' \times 42'' = 0.91 \text{ in}^2$$

Use 3 (#4) Top & Bottom

Note: #4 bars will be used both for transverse and longitudinal reinforcement

Steel Plate Bending Check:

UPLIFT FORCE  $T = 915 \text{ lb}$

BEARING FORCE  $C = 1708 \text{ lb}$

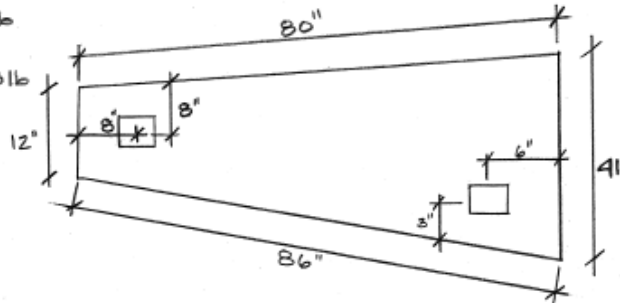

\*\* NOTE: BOLTS ARE TO BE PLACED 2" FROM EACH EDGE OF PLATE U.N.O.

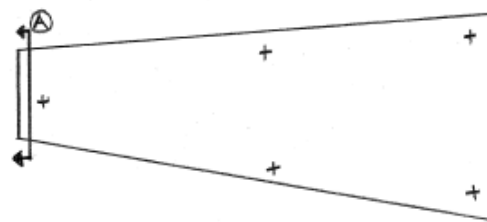

→ ASSUME CONDITION IS PINNED @ LOCATION OF BOLTS

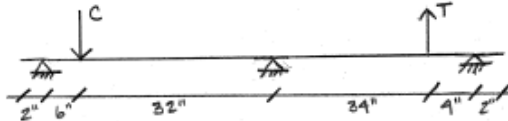

$$M_{max} = Pab / L \quad \text{[AISC Tab. 3-23]}$$

$$M_{max} = [915 * (34) * (4)] / 38 = 3275 \text{ lb} \cdot \text{in.}$$

#	A	$\bar{Y}$	$A\bar{Y}$
1	$0.75 \text{ in}^2$	$1.5"$	$1.125 \text{ in}^3$
2	$2.63 \text{ in}^2$	$2.875"$	$7.547 \text{ in}^3$

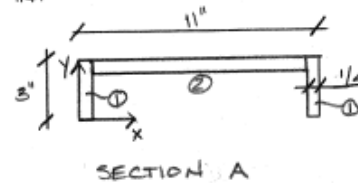

$$\bar{Y} = [2(1.125 \text{ in}^3) + 7.547 \text{ in}^3] / [2(0.75 \text{ in}^2) + 2.63 \text{ in}^2]$$

$$\bar{Y} = 2.38"$$

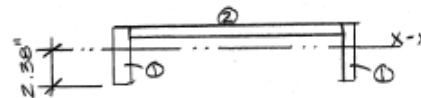

$$I_{xx} = \frac{1}{12} bh^3 + Ad^2$$

$$I_{xx①} = \frac{1}{12} (0.25") (3")^3 + (0.75 \text{ in}^2) (2.5" - 2.38")^2 = 0.5733 \text{ in}^4$$

$$I_{xx②} = \frac{1}{12} (10.5") (0.25")^3 + (2.63 \text{ in}^2) (3" - 0.125" - 2.38")^2 = 0.6581 \text{ in}^4$$

$$I_{xx} = 2(0.5733 \text{ in}^4) + (0.6581 \text{ in}^4)$$

$$I_{xx} = \underline{1.805 \text{ in}^4}$$

CHECK BENDING STRESS

$$\sigma = M y / I$$

$$\sigma = (3275 \text{ lb}\cdot\text{in} \times 2.38") / 1.805 \text{ in}^4 = 4.32 \text{ ksi} < 36 \text{ ksi} \quad \text{O.K.}$$

CHECK DEFLECTION

NOTE: WE MAY BE ABLE TO ASSUME THE BOLT IS A FIXED CONNECTION

FLEXURE OCCURS WHEN:  
 SPAN / DEPTH > 5

$$6" / 3/4" = 8 > 5 \therefore \text{BOLT WILL BEND}$$

DEFLECTION CALC WILL ASSUME BOLT IS PINNED CONNECTION NOT FIXED

$$\Delta_{\text{max}} = [P a b (a + 2b) \sqrt{3a(a + 2b)}] / 27 E I L$$

$$\Delta_{\text{max}} = \frac{[0.915 \text{ k} (39") (4") (39" + 2(4")) \sqrt{3(39") (39" + 2(4"))}] }{27 (29,000 \text{ KSI}) (1.805 \text{ in}^4) (38")}$$

$$\Delta_{\text{max}} = 0.0081" \quad \text{O.K.}$$

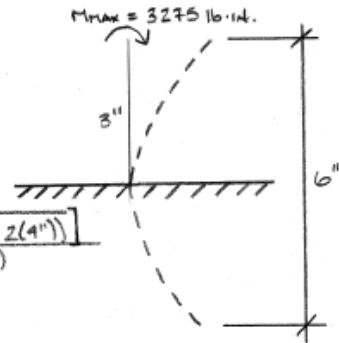
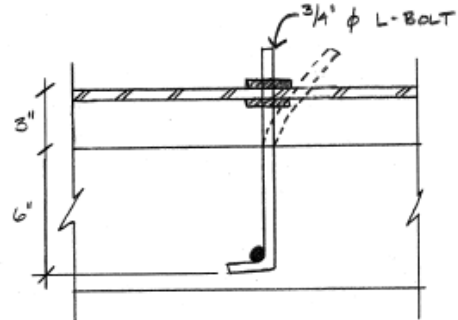

L-Bolt Pull-Out Check:

CHECK PULL-OUT STRENGTH OF L-BOLTS

USE  $3/4"$   $\phi$  L-BOLTS TO SECURE STEEL  $\overline{P}$  TO FOUNDATION

EMBEDMENT LENGTH,  $h_{EMB} = 6"$

SHEAR STRENGTH CONC. ( $f'_V$ )

$$f'_V = 800 \text{ psi}$$

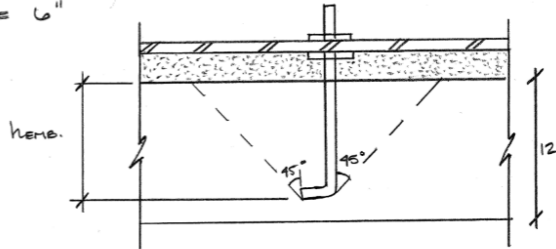

NOTE: IN ORDER TO DETERMINE PULL-OUT STRENGTH WE MUST FIND THE SURFACE AREA OF THE SHEAR CONE

SURFACE AREA OF CONE w/  $45^\circ$  SIDES:

$$SA_{\text{CONE}} = 1.4142 \pi h_{EMB}^2$$

$$SA_{\text{CONE}} = 1.4142 \pi (6")^2 = 159.9 \text{ in}^2$$

$$F_{\text{PULLOUT}} = f'_V \times SA_{\text{CONE}}$$

$$F_{\text{PULLOUT}} = 800 \text{ psi} (159.9 \text{ in}^2) = \underline{127.9 \text{ k}}$$

$$T = \underline{0.915 \text{ k}} \quad [\text{FROM LOAD CASE SUMMARY}]$$

$$127.9 \text{ k} \gg 0.915 \text{ k} \quad \text{O.K.}$$

USE  $3/4"$   $\phi$  L-BOLT w/  $h_{EMB} = 6"$

NOTE: SHEAR CONE FOR EACH BOLT DOES NOT OVERLAP w/ ANOTHER, WHICH MEANS SHEAR CONE SURFACE AREA WILL NOT BE REDUCED

**Anchoring Condition for Front Support**

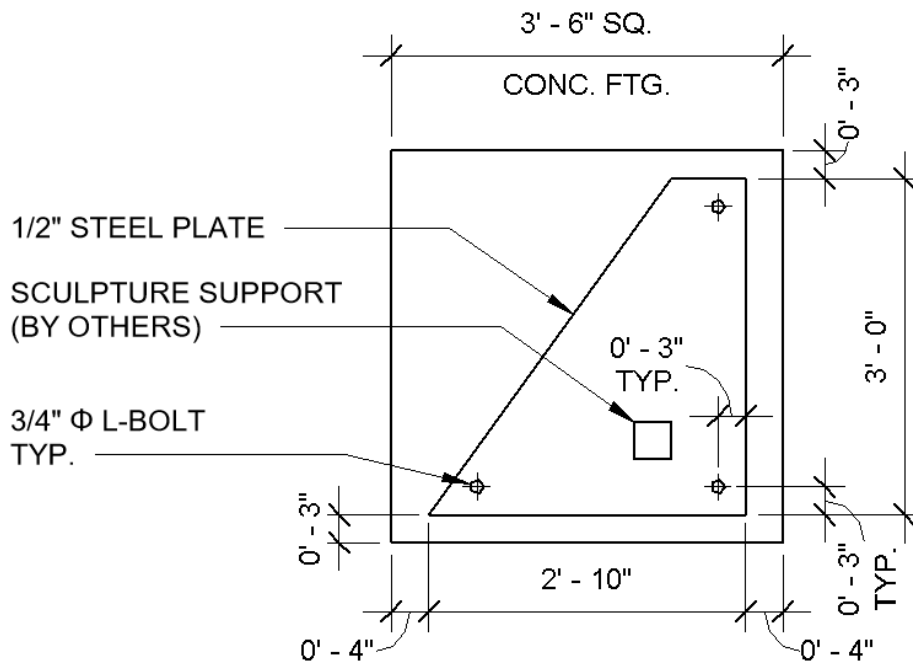

SINGLE SUPPORT BASE PLATE TO FOOTING DETAIL

PLAN VIEW

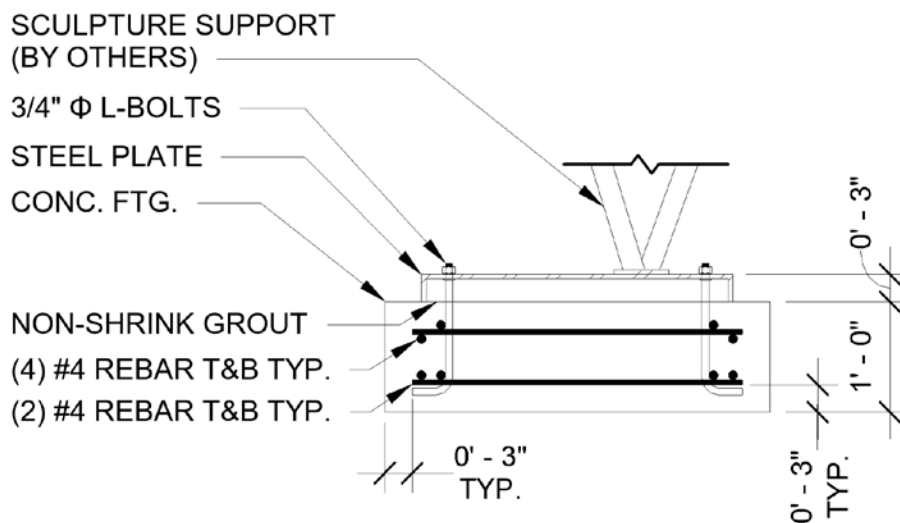

BASE PLATE TO FOOTING DETAIL

SECTION VIEW



**Anchoring Condition for Back Two Supports**

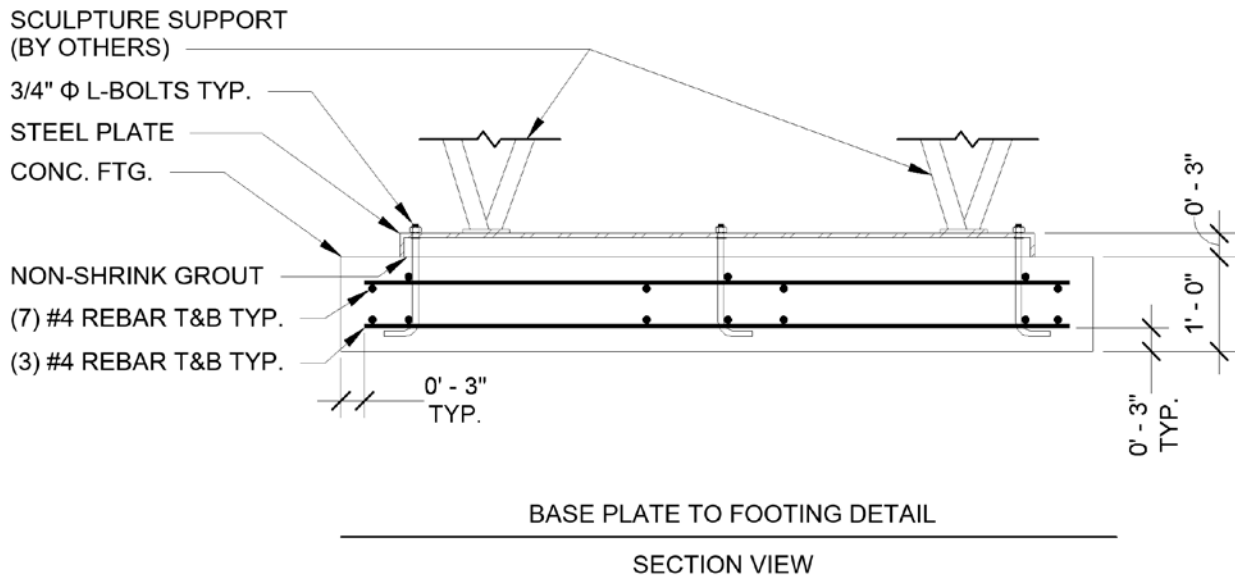
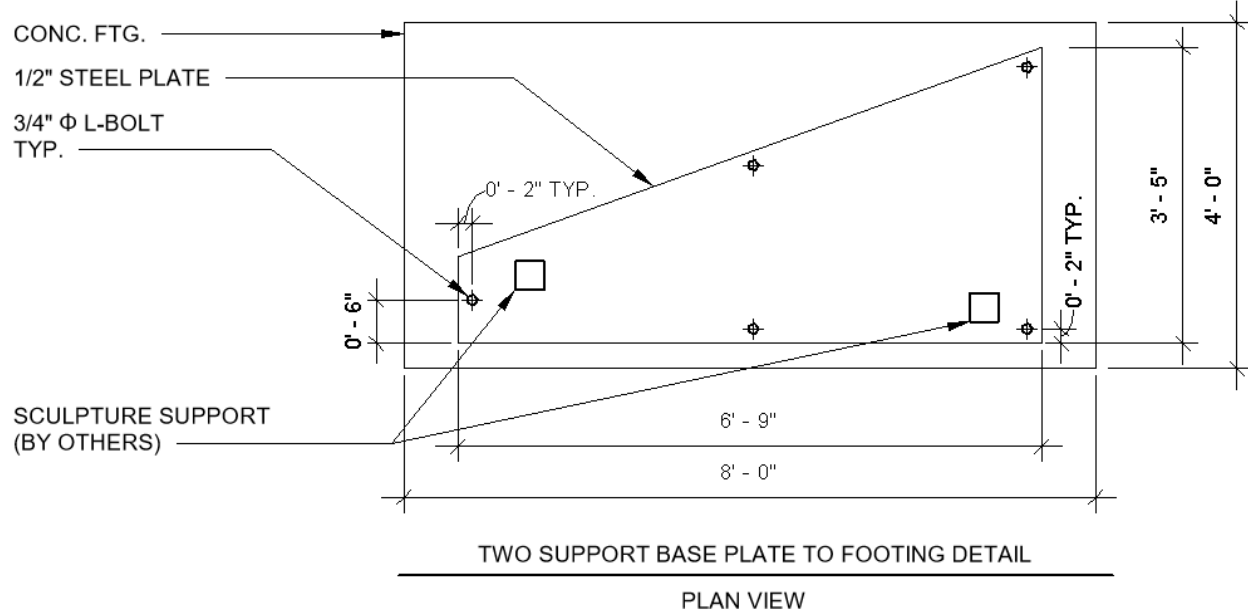

**Horse Location on Plan**

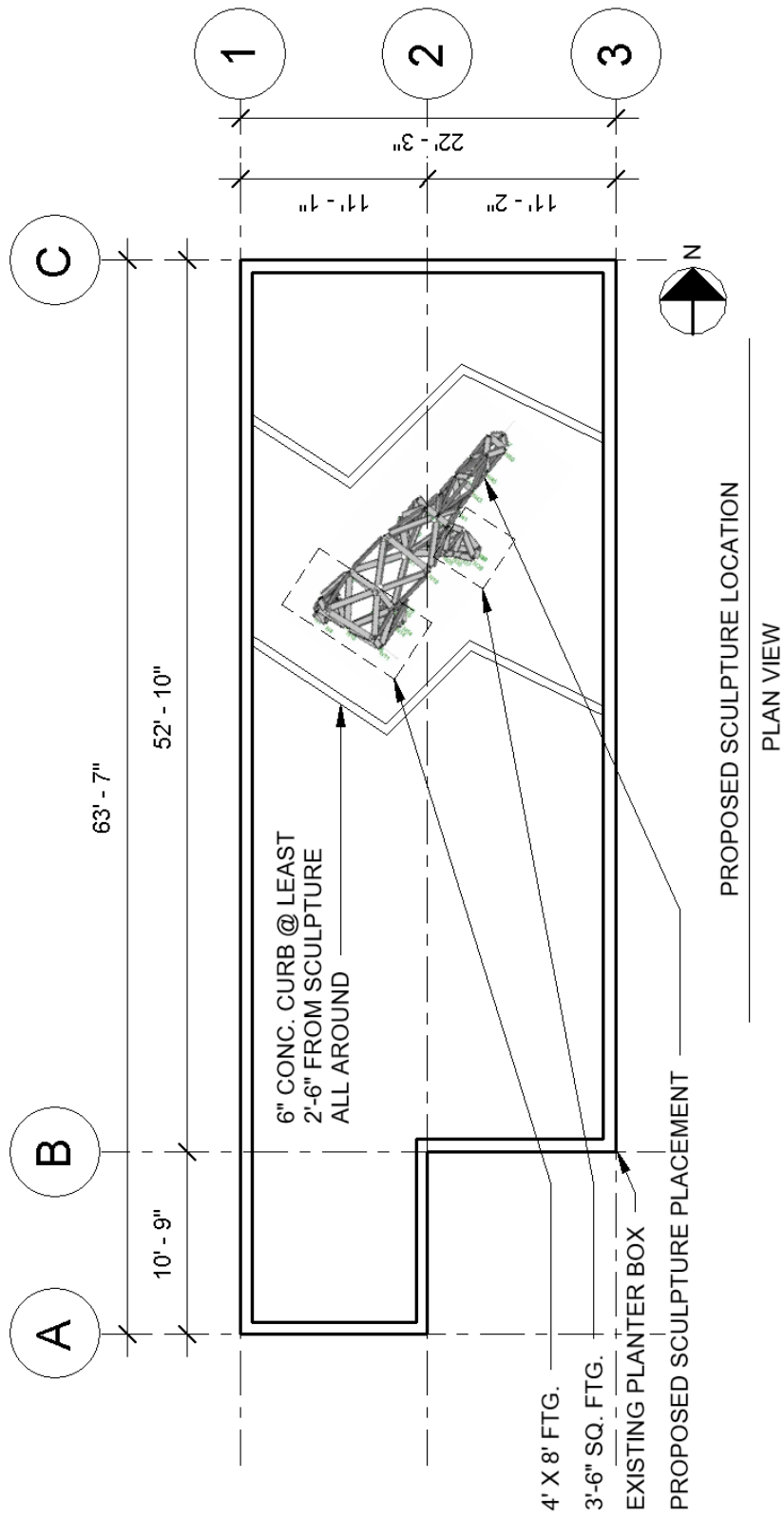

**Renderings of Finished Project**



*Figure 9: West Elevation Rendering*



*Figure 10: South Elevation Rendering*