

**REMOTELY-OPERATED VEHICLE ANIMAL TRACKING
TELEMETRY SYSTEM**

by

Kevin Silken and Amanda Strand

Senior Project

ELECTRICAL ENGINEERING DEPARTMENT

California Polytechnic State University

San Luis Obispo

2018

Table of Contents

<i>Section</i>	<i>Page</i>
Acknowledgements	iv
Abstract	iv
I Introduction	1
II Background	1
III Requirements	2
III-A ROV Types	3
III-A1 PUMA	4
III-A2 NOVA	4
III-A3 RMAX	5
III-B Transmit Antenna Requirement	6
III-C Project Focus Changes	6
IV Experimental Design	6
IV-A Receive Antenna	7
IV-B Amplifiers	8
IV-C Mixer (IF, LO, RF)	9
IV-C1 IF Port	10
IV-C2 LO Port	11
IV-C3 RF Port	11
IV-D Voltage-Controlled Oscillator (VCO)	11
IV-E Transmit Antenna	11
IV-F Low Dropout Voltage Regulator (LDO)	12
IV-G Power Supply	12
V Test Plans	13
V-A 165 MHz Amplifier	13

V-B Mixer 13

V-C VCO 14

V-D LDO 15

V-E Antenna 15

VI Development and Construction 17

 VI-A Costs and Benefits of Using the Milling Machine 17

 VI-B Using the Reflow Oven 19

VII Integration and Results 20

VIII Conclusion 22

Appendix A: Senior Project Analysis 24

Appendix B: Parts List and Costs 27

Appendix C: PC Board Layout 27

Appendix D: Hardware Configuration/Layout 29

Appendix E: Schedule - Time Estimates 30

List of Figures

<i>Figures</i>	<i>Page</i>
1 Holohil MI-2M Animal Tracking Collars	3
2 PUMA ROV	4
3 PUMA ROV with Wings	4
4 NOVA ROV	5
5 RMAX Front View	5
6 Biotrack Yagi-Uda Antenna	8
7 Airblade TX Antenna	12
8 Milling Machine Attempts	18
9 ProtoFlow E Reflow Oven	19
10 Biotrack Yagi-Uda E and H Plane Beamwidth	21
11 Integrated VCO and LDO	22
12 Mixer PCB Layout	28
13 LNA PCB Layout	28
14 LDO PCB Layout	29
15 Level 1 Block Diagram	29

List of Tables

<i>Table</i>	<i>Page</i>
I Sample Collar Verification	3
II Parts List	7
III Yagi-Uda Antenna Specifications	8
IV Operating Current and Voltage Characterization	9
V Range and Calculated Receive Power	10
VI Supply Components and Required Currents	12
VII VCO Characterization	22
VIII Bill of Materials	27

ACKNOWLEDGMENTS

We would like to acknowledge and give thanks to the people who have given their time and effort in support of this project. In particular, we give recognition to Khulan Orgil for her support during the late nights of testing. Thank you for looking at our project with a new set of eyes. We would also like to thank Jack McGee and Wyll Sol for being patient with us and giving information regarding the PUMA and NOVA remotely-operated vehicles (ROVs). We would like to thank Dr. Dean Arakaki for the invaluable advice and constructive criticism he gave during the course of this project. We thank him for proofreading all of our reports. Dr. Marc Horney is the last but not the least individual we thank for contributing to this project. He supported us through all decisions. He also put in the initial effort to make this project a possibility. Finally, we would like to thank the Electrical Engineering Department at California Polytechnic State University, San Luis Obispo for providing funding and equipment that were crucial for this project.

ABSTRACT

This paper's design focus is a Remotely Operated Vehicle (ROV) payload receiver system. An ROV is a remote control vehicle operated from a nearby position. This project's ROV is an aerial vehicle flown by a crew of at least four operators. The ROV receiver is needed to The receiver system receives a 165 MHz collar beacon signal, upconverts the signal to 3.4 GHz, then transmits the 3.4 GHz signal to the ROV operator. The collar beacon signal indicates the location of a tracking collar placed on an animal, fishers in this instance. The transmitted signal is received by the ROV operator and indicates the beacon signal's direction. The ROV is directed by the operator toward the beacon signal's location. This improves animal tracking efficiency, saving hours. The result of the project is a transceiver system capable of receiving a signal from approximately 3,500 meters maximum range, processing the signal, and transmitting the signal a maximum 915 meters (1000 yards) back to the ROV operator. The maximum distance between the operator and ROV is 1000 yards due to remote control limitations.

I. INTRODUCTION

TRADITIONAL animal tracking methods require biologists in the field scanning for animal collars. The field biologist is usually unaware of nearby animal collars and most often begins out-of-range. Therefore, this tracking method could require between 3 and 12 hours per day. Remotely-Operated Vehicles (ROVs) reduce the time to between 0.5 and 4.0 hours. Biologists can fly ROVs over large areas and scan habitats for animal collars. Traditional methods can further be improved by implementing a system that enables tracking the direction in which the animal collar is relative to the ROV.

The project goal is to design an ROV telemetry system that directs ROV operators toward animal collars. The system detects collar beacon signals that indicate an animal's location. The telemetry system receives the beacon signal through a receive antenna, then upconverts (165 MHz to 3.4 GHz) and re-transmits the signal through a separate transmit antenna to the ROV operator at the ground station. This upconversion is required to enable use of a re-purposed drone IR camera's 3.4 GHz transceiver system. To determine design constraints the project team used the Aerospace Department's NOVA ROV, a glider, which can carry a maximum payload of 3.7 lbs.

The final project result is a transceiver system designed to receive the beacon signal through a 165 MHz Yagi-Uda antenna, upconvert it to 3.4 GHz, and transmit the signal through the 3.4 GHz airblade antenna.

Future product goals include tracking fishers, a relative of the weasel that lives in the Sierra Nevada Mountains. The collars collect data such as ambient temperature and humidity and record the animals' coordinates through GPS communications. Fisher tracking documents animal movement patterns, habitat utilization, population demographics, and snaring and poaching incidents. The system receives collar model LiteTrack40 and LiteTrack60 beacon signals at 164.7 MHz and 165.8 MHz, respectively. The system detects collar signals between 164 and 168 MHz. The goal is a maximum drone-to-collar range of 3,500 meters.

II. BACKGROUND

Wildlife biologists collect weather and Global Positioning System (GPS) data about animals and their habitats in order to understand how species migrate and evolve over time [1]. Animal movement is used in

conjunction with data, such as the current temperature at time of update, to determine the effects of climate change and habitat loss, evaluate a specie's recovery from poaching, and other activities. An effective data collection method is low profile animal collars, typically 10% of the animal's body weight. The collar stores current temperature, humidity, and GPS data measured and uploaded via satellite. This data informs biologists of the animals' movements and habitat conditions (i.e. climate). Researchers wirelessly collect animal collar data at periodic intervals. The data is collected through field research because the collar stores data within itself rather than uploading the data to a computer. Other systems utilize a satellite to measure and upload the data to a computer at a remote station. The data is then available to researchers through the database [1]. Database storage systems tend to be more expensive than storing data on the collar. This makes transition away from the collar collecting and storing its own data more difficult. The current data download system used to upload data from the collar has a maximum 1,000 meter range. This project's receiver system must be capable of guiding the operator to within the 1,000 meter radius around the collar. This doubles the original maximum data download distance to approximately 2,000 meters

One of the most time consuming problems for data collectors is finding the animal subject. A potential solution is to use an ROV with a mounted telemetry system that helps the operator track the collar's signal. This feedback allows the operator to steer the ROV toward the collar and collect the data more efficiently.

III. REQUIREMENTS

The purpose of the system is to aid the ROV operator in navigating the ROV toward the animal collar. The system design is influenced by multiple conditions. The collar beacon frequency determines the system receive frequency. The ROV on which the system will be mounted determines the system weight and size limitations. The Aerospace Department's 3.4 GHz transceiver system determines the transmit frequency. Most collars used to track the animals have antennas that operate between 150 MHz and 180 MHz. Two sample Holohil MI-2M collars are shown in Fig. 1 below. These sample collars had been tested prior to being delivered and are labeled with their measured frequencies. The Holohil collars were tested upon arrival and verified operational at the labeled frequencies, shown in Table I. The collar beacon signals were measured with an Air802 antenna and the power levels calculated by solving the Friis Transmission Formula (equation 1) for P_t .

The collars were turned on and placed 10 cm from the Air802 antenna. The Air802 antenna was connected to an HP 8593E Spectrum Analyzer. P_r was recorded from the spectrum analyzer with the cable loss added. Cable loss was stated in the Air802 datasheet [2]. The gain of a monopole antenna was used for G_t because the collar uses a wire monopole. G_r was obtained from the Air802 datasheet. No expected transmit power level was provided in the datasheet [3] with which to compare. The results are displayed in Table V.

$$P_r \text{ (dBm)} = P_t \text{ (dBm)} + G_t \text{ (dB)} + G_r \text{ (dB)} + 20 \log_{10}\left(\frac{\lambda}{4\pi R}\right) \quad (1)$$

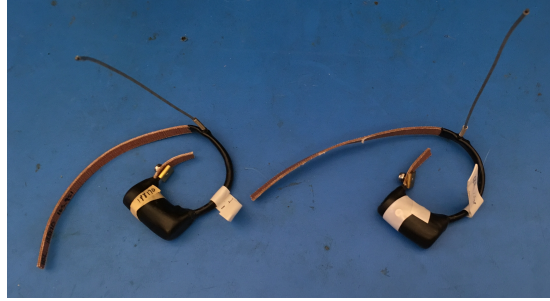

Fig. 1: Holohil MI-2M Animal Tracking Collars

TABLE I: Sample Collar Verification

Collar Part No.	Labeled Operating Frequency [MHz]	Measured Operating Frequency [MHz]	Frequency Percent Error (%)	Measured Power Level [dBm]
188170	165.951	165.960	0.95	-20.46
129338	164.839	164.850	1.31	-14.12

A. ROV Types

The Cal Poly Aerospace Department has three ROVs: the PUMA, shown in Fig. 2; the NOVA, shown in Fig. 4; and the RMAX, shown in Fig. 5. The ROVs are kept in the Building 007 UAV Lab. One of these drones will be mounted with the receive antenna, repeater system, and transmit antenna designed for the telemetry system. The Aerospace Department and the flight environment determine which drone is used. For tracking fishers, the ROV flies through a wooded environment, requiring a small frame, such as a glider.

1) *PUMA*: Pictured in Fig. 2 below, it has a length of 1.4 meters, wingspan of 2.8 meters, speed of 25 to 45 knots, and weighs 14 lbs. It can carry a maximum weight limit of 2 lbs and flies at a height of 152 meters. The payload box has maximum dimensions of 12 cm x 18 cm x 18 cm with respect to the xyz coordinate system (all following dimensions use this format unless otherwise specified, the coordinate system is defined in the figure with the +y-axis going into the picture). The maximum antenna dimensions are 1 ft x 1 ft x 2 in positioned above the payload (see Fig. 2 and 3). These were chosen to help prevent additional wind resistance and changes to the center of gravity.

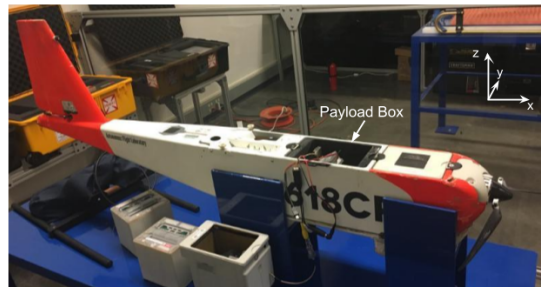

Fig. 2: PUMA ROV Demonstrating Payload Position



Fig. 3: PUMA ROV with Wings Attached

2) *NOVA*: Pictured in Fig. 4 below, it has a length of 1.45 meters, wingspan of 2.77 meters, speed of 30-58 knots, and weighs 17 lbs. The payload weight limit is 3.7 lbs. The payload lid, outlined by a purple box in the figure, is held onto the NOVA by a screw at each corner. This lid has no extra holes drilled into it that enable cables running to or from the payload. Holes are necessary to run cables from antennas to the transceiver system as well as mounting the antenna on top of the ROV. The maximum antenna dimensions are 1 ft x 1 ft x 2 in positioned above the payload (see Fig. 4). These dimensions were chosen for the same reasons as the PUMA. The NOVA lands by sliding to a halt. To prevent damage to the antenna, it can not be mounted underneath the NOVA.

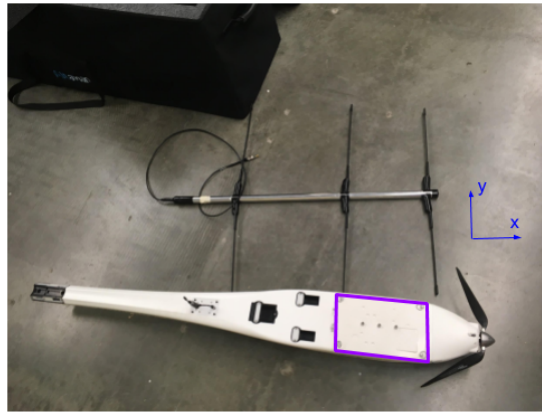

Fig. 4: NOVA without Wings compared to Biotrack 165 MHz Yagi-Uda Antenna

3) *RMAX*: Pictured in Fig. 5 below, it is much more robust than the PUMA or NOVA and is capable of carrying a payload of 66 lbs. The length, width, and height are 3.63 meters, 0.72 meters, and 1.08 meters respectively. The telemetry system payload box maximum dimensions are 13 in x 21 in x 24 in (the y-axis is going into the figure). Due to the slower flying speed of 8 to 13 knots, the antenna dimensions are not strict. The effects of the antenna on center of gravity and air resistance are insignificant. The antenna can be any design that does not interfere with correct operation of the *RMAX*. Correct operation is defined as the ability to fly and land without damage to the *RMAX* or crew.



Fig. 5: RMAX Front View

B. Transmit Antenna Requirement

The Aerospace Department has a small, IBCrazy airblade antenna that operates at 3.4 GHz. No datasheet is available for this antenna, but can be found at [4]. This antenna was used in an IR camera system that was mounted to the drone. The airblade antenna has been re-purposed to act as the transmit antenna along with its receiver system, which will be used to receive the signal at the operator. This antenna is utilized because it is small (the diameter is 70 mm), lightweight (it weighs 16.4 g), and the Aerospace Department has a working receiver system for the 3.4 GHz antenna.

C. Project Focus Changes

Late during the winter quarter 2018, Dr. Horney purchased two Yagi-Uda antennas from Lotek. At this time, the senior project group was told that the PUMA had a maximum payload of 5 lbs, the Aerospace Department did not yet have the NOVA, and the RMAX was considered the ROV the project group would use to implement the prototype tracking system. Though the PUMA is the ROV for which the final result will be designed, the RMAX was determined as the starting point for the design because of the higher payload weight limit. The Yagi-Uda antennas were chosen because they operate at 165 MHz and they are lightweight (800 g). The system was planned for implementation on the RMAX so, even though the antennas had larger dimensions, they could be used for the design. After the antennas were ordered and received, Dr. Drake, the Aerospace Department drone manager, informed the project group that it could not use the RMAX as the project ROV. The RMAX is too large to easily maneuver through trees in the Sierra Nevada mountains to track the fishers and is too loud. The loud motor increases the chances of scaring away the animals when tracking them. At this point the project group decided to use the PUMA since it had a weight limit of 5 lbs. Halfway through the spring quarter 2018, the project group was informed that the weight limit for the PUMA was 2 lbs. At this time the Aerospace Department received the NOVA drone. This has a weight limit of 3.7 lbs so the project group switched to designing on the NOVA.

IV. EXPERIMENTAL DESIGN

This design is inspired by the EE 440 and EE 480 Wireless Communications lecture and laboratory classes. In EE 480, the final project was to create a wireless transmit and receive system using equipment in the

Cal Poly Microwaves Lab. The system transmits and receives at 3.4 GHz and 165 MHz respectively.

TABLE II: Parts List

Component	Part Number
Receive Antenna	N/A
Mixer	LT5579IUH
Transmit Antenna	4700
Amplifier	MAAL-010704
VCO	HMC388LP4
LDO	LT3061EMS8E
Power Supply	N/A

A. Receive Antenna

The receive antenna is designed to receive the beacon signal from the LiteTrack 40 and 60 collars. The beacon frequencies are 164.7 MHz and 165.8 MHz. Due to the wavelength around these frequencies ($\lambda = 1.8 \text{ meters}$), the antenna needs to be comparable in size. The elements on the antenna and the boom are approximately $\lambda/2$ in length. The boom is the main support beam, which holds the active and parasitic elements. The parasitic elements are the reflector and directors, which aid in increasing gain and directivity. The Yagi-Uda antenna chosen for the project has a 4 MHz bandwidth. The antenna is designed to operate between 164 and 168 MHz, so it is able to receive each collar's beacon signal.

A directional antenna is needed to determine the direction of the received signal. Directional antennas have beamwidth limits. These limits determine the origin of the received signal. This makes directional antennas useful for locating a beacon with greater accuracy than an omnidirectional antenna. For an antenna to be directional, most of the power in the radiated signal lies in a small area. The Biotrack Yagi-Uda antenna's half-power beamwidth is 80 degrees as seen in Fig. 10.

Yagi-Uda antenna's gain and directivity increase by using more directors. The size of the Yagi-Uda increases as more directors are added. Yagi-Udas tend to be larger antennas (about one wavelength long for the boom and $\frac{1}{5}$ to $\frac{3}{4}$ a wavelength for each element). The total area used by the Yagi-Uda at 165 MHz

is 100 cm long by 95 cm wide. The exact element lengths are provided in Table III and a picture of the Biotrack Yagi-Uda antenna is provided in Fig. 6.

Another antenna option not explored in this project, but potentially useful for future work is a half-wave wire dipole. The dipole antenna's null is used to pinpoint the beacon's direction. Due to the omnidirectional characteristics of a dipole, nulls in the radiation pattern are more prominent than the peak signal. Additionally, the wire dipole is lighter compared to the Yagi-Uda antenna. The disadvantage is determining how to use the null of the antenna rather than the peak power level.



Fig. 6: Biotrack Yagi-Uda Antenna (from left to right: director, active element, reflector)

TABLE III: Yagi-Uda Antenna Specifications

Antenna Parameter	Value
Boom	100 cm
Reflector	85 cm
Active Element	75 cm
Director	65 cm
Weight	800 g
Gain	6 dBd

B. Amplifiers

The MAAL-010704 is a wide-band amplifier that can amplify signals between 0.1 and 3.5 GHz and can be used to amplify signals at the RF and IF mixer ports. The circuit design at each port only varies by

changing the passive component values to set each port’s operating frequency.

C. Mixer (IF, LO, RF)

The mixer must upconvert from 165 MHz to 3.4 GHz and requires a 3.235 GHz LO. The LT5579 mixer was recommended to the senior project team by Analog Device’s staff because the datasheet listed the matching network components and could operate at the design frequencies. Additionally, the minimal detectable signal (MDS) is -72.3 dBm. This was calculated using equation 2 from the Pozar book [5]. The LO drive level is -1 dBm but can operate with a maximum LO power of 10 dBm.

During the initial testing procedure, the mixer did not work as specified by the datasheet. The RF output followed the LO input signal rather than yielding a mix of the LO and IF input signals. The test was set up using parameters specified in the datasheet: $V_{CC} = 3.3 V$, $f_{IF} = 0.165 GHz$ at -10 dBm, and $f_{LO} = 3.235 GHz$ at -1 dBm. Given these parameters, the mixer should operate as detailed in the datasheet [6]. During the last week the project group found the VCOs output a higher power signal when given greater current. This led to the belief that the mixer was not receiving sufficient current from the bench power supply. The mixer was tested again with a current limited power supply and proved proved the mixer was not drawing sufficient current. The mixer operated correctly and mixed the input signals. At the time of this discovery, insufficient time remained to characterize the mixer. Table IV lists the supply current and voltage needed for correct operation.

TABLE IV: Operating Current and Voltage Characterization

V_{CC} [V]	I_{CC} [mA]	P_{RF} [dBm]	f_{RF} [GHz]
3.001	77.6	N/A	N/A
3.11	83.7	N/A	N/A
3.199	95.3	-35.58	3.4
3.298	101.4	-35.52	3.4
3.401	107.9	-35.49	3.4
3.497	113.8	-35.4	3.4

$$MDS [dB] = 10 \log_{10}(kT_0) + 10 \log_{10}(B) + F (dB) + \frac{S_o}{N_o} \quad (2)$$

$$k = 1.38 * 10^{-23} \frac{m^2kg}{s^2K}$$

$$T_0 = 290K$$

$$B = 930 MHz$$

$$F = 12 dB$$

$$S_o = -5 dBm$$

$$N_o = -5.355 * 10^{11} dBm$$

$$MDS = -72.3 dBm$$

Another point to note regarding the mixers is the poor output power. The selected mixer is an active mixer. It should have an insertion gain around 2-4 dB rather than insertion loss around 20 dB. A possible cause of this discrepancy is the transmission line design on the PCB. The datasheet specifies the need for specific characteristic impedance between the input ports and the mixer IC. The designed tracewidths meet the width required to match the characteristic impedance at the port input frequency. The problem, which may cause large reflections in the traces is the rapid tracewidth decrease as it approaches the IC. With more time and research, an optimal design which gradually reduces the tracewidth and minimize return loss is possible.

1) *IF Port*: The amplifier between the receive antenna and IF port requires high gain around 20 dB to increase the receive range. The MDS is -72.3 dBm. The MAAL-010704 has a gain of 22 dB at the 165 MHz IF frequency. The minimum receive power from the antenna must be -94.3 dBm to operate above the mixer's MDS. Using equation 1 and assuming the collar's transmit antenna is a dipole, the maximum range this system could detect is about 3,500 m.

TABLE V: Comparison of Ranges to Expected Receive Power

Case	P_t (dBm)	G_t (dB)	G_r (dB)	λ (m)	R (m)	P_r (dBm)
1	-14.12	1.76	6	1.818	1,000	-83.16
2	-14.12	1.76	6	1.818	3,500	-94.04

2) *LO Port:* The voltage controlled oscillator (VCO) 3.235 GHz output is directly compatible with the LO port. Two sample VCOs were tested and output 3.235 GHz signals at -0.4 dBm and -0.3 dBm. The mixer requires between -1 dBm and 10 dBm. At 3.235 GHz, the gain of the MAAL-010704 amplifier is about 10 dB and would raise the VCO's power to between 9.6 dBm and 9.7 dBm. The VCO does not need an amplifier to drive the LO port.

3) *RF Port:* Adding amplifiers to the RF port will supply the transmit antenna with more power and increase the range between the operator and ROV within the limits of the remote control. The gain of the MAAL-010704 amplifier at 3.4 GHz is about 10 dB. Further testing needs to be done with the Aerospace Departments receiver system to determine its MDS and the attainable range resulting from that value.

D. Voltage-Controlled Oscillator (VCO)

The mixer requires a minimum -1 dBm power level. To upconvert the signal to the correct frequency, the mixer's LO must receive a 3.235 GHz signal and at least -1 dBm power level. The HMC388 was chosen as the VCO because one of the project group members had used the HMC385, a similar component, previously and the part worked within specifications at 2.4 GHz. The HMC388 can be tuned between 3.15 and 3.4 GHz. Additionally the datasheet output power is 4.9 dBm. This VCO is capable of directly driving the mixer LO port.

E. Transmit Antenna

The transmit antenna, shown in Fig. 7 below, has been supplied by the Cal Poly Aerospace Department. The antenna is a 3.4 GHz airblade antenna. The Aerospace Department did not give the receiver system so it could not be tested for receiver gain characteristics. However, according to the department, the drone must always be within 1,000 yards (915 meters) of its controller.

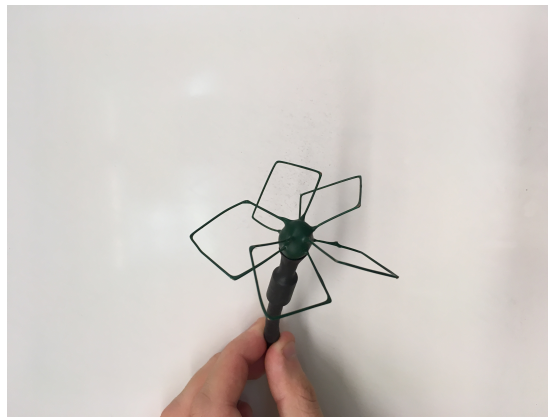

Fig. 7: Airblade TX Antenna

F. Low Dropout Voltage Regulator (LDO)

The LDOs will source the appropriate voltage and current to all the components in the system. The LDO input voltage range is 1.6 V to 45 V while its output voltage range is 0.6 V to 19 V.

TABLE VI: List of system components and required LDO supply current

Component (Voltage supplied by LDO)	Number of LDOs	LDO Voltage [V]	Required Source Current [mA]
Mixer (V_{CC})	3	3.30	226.00
Amplifiers (V_{CC})	2	3.00	60.00 (each)
VCO (V_{CC})	1	3.00	39.00
VCO (V_{tune})	1	2.63	0.01

Total current: 385 mA

G. Power Supply

The power supply will consist of one battery pack. The senior project group suggests purchasing the Energizer 4-Pack AAA Rechargeable Nickel Metal Hydride Battery because it is rated at 850 mAh; therefore, the system would last about 2 hours before the battery would need to be recharged.

V. TEST PLANS

A. 165 MHz Amplifier

- 1) Verify pinout reliability
- 2) Measure gain over frequency range 140 MHz to 190 MHz
 - a) Set signal generator to output a 165 MHz signal at -10 dBm power level
 - b) Measure input signal power directly on Spectrum Analyzer through an SMA-to-SMA cable - used to determine the cable loss
 - c) Increment input frequency in 2 MHz steps recording the output power level
 - d) Add cable loss to the input power and all output power measurements
 - e) Plot output power vs. frequency to evaluate performance and compare to datasheet values
- 3) Measure Return Loss at input and output ports
 - a) Calibrate VNA for 1 port reflection only measurements across 140 MHz to 190 MHz
 - b) Connect the amplifier's input port to VNA port 1 and place 50 Ω load on amplifier's output port
 - c) Record tabular data using VNA Capture
 - d) Switch to measure the amplifier's output port: connect the amplifier's output port to VNA port 1 and place 50 Ω load on amplifier's input port
 - e) Record tabular data using VNA Capture
- 4) Measure effects of decreased power supply (V_{CC}) on performance
 - a) Initially set $V_{CC} = 5$ V [absolute maximum value is 5.5 V according to datasheet] and input a 165 MHz signal at -10 dBm
 - b) Decrease V_{CC} in 0.2 V steps to 1 V [typical value is 3 V according to datasheet] and record the output signal power level

The same procedure will be followed for 3.4 GHz amplifier, but over a 100 MHz bandwidth instead of the 50 MHz bandwidth used for the 165 MHz amplifier.

B. Mixer

- 1) Verify pinout reliability

- 2) Input 0.165 GHz at -10 dBm to the IF port, 3.235 GHz at -1 dBm to the LO port, and connect the RF port to the spectrum analyzer
- 3) Record the first and third order spurious frequency power levels
- 4) Measure the MDS: Decrease the IF power level in 5 dB steps until no signal is perceivable at the spectrum analyzer
 - a) Decrease the step size in the range of minimum signal to improve the resolution
- 5) With 0.165 GHz signal at -10 dBm input at the IF port, input a 3.235 GHz signal at 8 dBm to the LO port (maximum input LO signal is rated for 10 dBm)
 - a) Decrease LO input in 1 dB steps to -10 dBm or until no signal is discernible recording the output power level
- 6) Measure Conversion Loss:

$$ConversionLoss = P_{RF}[dBm] - P_{IF}[dBm] \quad (3)$$

- a) Using equation 3 calculate the conversion loss and compare with datasheet value [-1 dB to 0 dB according to datasheet]
- 7) Measure effects of varied power supply (V_{CC}) on performance
 - a) Initially set $V_{CC} = 3.15$ V [minimum value according to datasheet] and input a 165 MHz signal at -10 dBm
 - b) Increase V_{CC} in 0.05 V steps to 3.6 V [maximum value according to the datasheet; absolute maximum is 4 V] and record the output signal power level

C. VCO

- 1) Determine V_{tune} voltage required to output 3.235 GHz
- 2) Measure effects of varied power supply (V_{CC}) on performance
 - a) Initially set $V_{CC} = 2.5$ V and input V_{tune} found in step 1 [$V_{tune} = 2.67$ V]
 - b) Increase V_{CC} in 0.05 V steps to 3.25 V [absolute maximum is 3.5 V according to the datasheet] and record the output signal power level

D. LDO

- 1) Determine turn-on voltage
 - a) Begin with input voltage $V_{in} = 0$ V
 - b) Increase V_{in} in 0.2 V steps until an output voltage near V_{in} is measured (indicates LDO is tracking the input)
- 2) Determine maximum differential voltage - Voltage Headroom
 - a) Set V_{in} so the design output voltage is observed $-V_{in,opt}$
 - b) Increase V_{in} in 0.2 V steps until a 0.2 V deviation from the design output is measured and record the V_{in} voltage, which represents the maximum V_{in} for desired operation
 - c) Reset V_{in} to the value prior to increase
 - d) Decrease V_{in} in 0.2 V steps until a 0.2 V deviation from the design output is measured and record the V_{in} voltage, which represents the minimum V_{in} for desired operation
 - e) Calculate the differential voltage using equations 4 and 5

$$V_{pos,dif} = V_{in,max} - V_{in,opt} \quad (4)$$

$$V_{neg,dif} = V_{in,opt} - V_{in,min} \quad (5)$$

E. Antenna

- 1) Visually inspect antenna for defects such as bent elements
- 2) Measure $|S_{11}|$ (Return Loss)
 - a) Calibrate the VNA for single port, reflection only across the desired frequency range
 - b) Connect antenna to VNA port 1
 - c) Record return loss data provided through VNA Capture application
- 3) Measure E-Plane Beamwidth
 - a) Attach a known antenna to the stationary mount in the Building 20-116 anechoic chamber. This is the transmitting antenna.
 - b) Attach the antenna to be measured to the mount on the servo motor. This is the receive antenna
 - c) Align the antennas so the receive antenna sweeps the E-Plane and the transmit antenna matches polarization - Co-Pol Measurement

- d) Open the AMS Labview application
- e) Under the Radiation Pattern tab
 - i) Set the polarization
 - ii) Set CW Frequency at the desired frequency
 - iii) Set the desired azimuth angle across which to sweep the antenna
 - iv) Press Run Rad Pattern Test
- f) Record the resulting radiation pattern
- g) Rotate the transmit antenna 90 *degrees* on its center axis - Cross-Pol Measurement
- h) Repeat steps d - f
- i) For each recorded plot, measure the Half-Power Beamwidth (HPBW) using equation 6.

$$HPBW = \theta_{-3dB}^+ - \theta_{-3dB}^- \quad (6)$$

4) Measure H-Plane Beamwidth

- a) Attach a known antenna to the stationary mount in the Building 20-116 anechoic chamber. This is the transmitting antenna.
- b) Attach the antenna to be measured to the mount on the servo motor. This is the receive antenna
- c) Align the antennas so the receive antenna sweeps the H-Plane and the transmit antenna matches polarization - Co-Pol Measurement
- d) Open the AMS Labview application
- e) Under the Radiation Pattern tab
 - i) Set the polarization
 - ii) Set CW Frequency at the desired frequency
 - iii) Set the desired azimuth angle across which to sweep the antenna
 - iv) Press Run Rad Pattern Test
- f) Record the resulting radiation pattern
- g) Rotate the transmit antenna 90 *degrees* on its center axis - Cross-Pol Measurement
- h) Repeat steps d - f
- i) For each recorded plot, measure the HPBW using equation 6

VI. DEVELOPMENT AND CONSTRUCTION

Before ordering the circuit boards through Bay Area Circuits, the hangar milling machine was used to mill the mixer. The substrate used for the milling process is described below.

Rogers Corps. RT/duroid 5870

$$\epsilon_r = 2.33$$

$$\text{Thickness} = 62 \pm 2 \text{ mil}$$

A. Costs and Benefits of Using the Milling Machine

Eagle CAD creates traces which are not directly compatible with CircuitCAM software due to additional traces lined on the board in the Gerber file. The additional traces represent intersections between component soldering pads and the traces connecting components, which resulted in extra lines milled and discontinuity between the trace and soldering pad caused by the extra lines, shown in Fig. 8b below. These traces are not visible when the file is viewed with a Gerber file viewer [7], shown in Fig. 12 below. Care needs to be taken when choosing trace widths due to added complication from the method Eagle uses to place traces as well as milling machine limitations. The milling machine limitations consist of a minimum 30 mil trace width which it is able to mill without error.

Working with Eagle is easier with respect to finding component layouts with accurate pin-outs and component sizes when compared with ADS in which the user may need to create the component design. Eagle permits the user to place physical components in a circuit then translates the components to their soldering pads automatically when producing the Gerber files.

The milling process took 5.5 hours and four etched designs to learn how the milling machine software CircuitCAM defines milling paths. The primary obstacle was finding a method to correct problems with Eagle CAD conversion and correctly mill the desired traces. *Open Path* lines were used to create an outline around the Eagle traces and pads as a method to mitigate additional trace lines added during conversion from the Eagle Gerber design files.

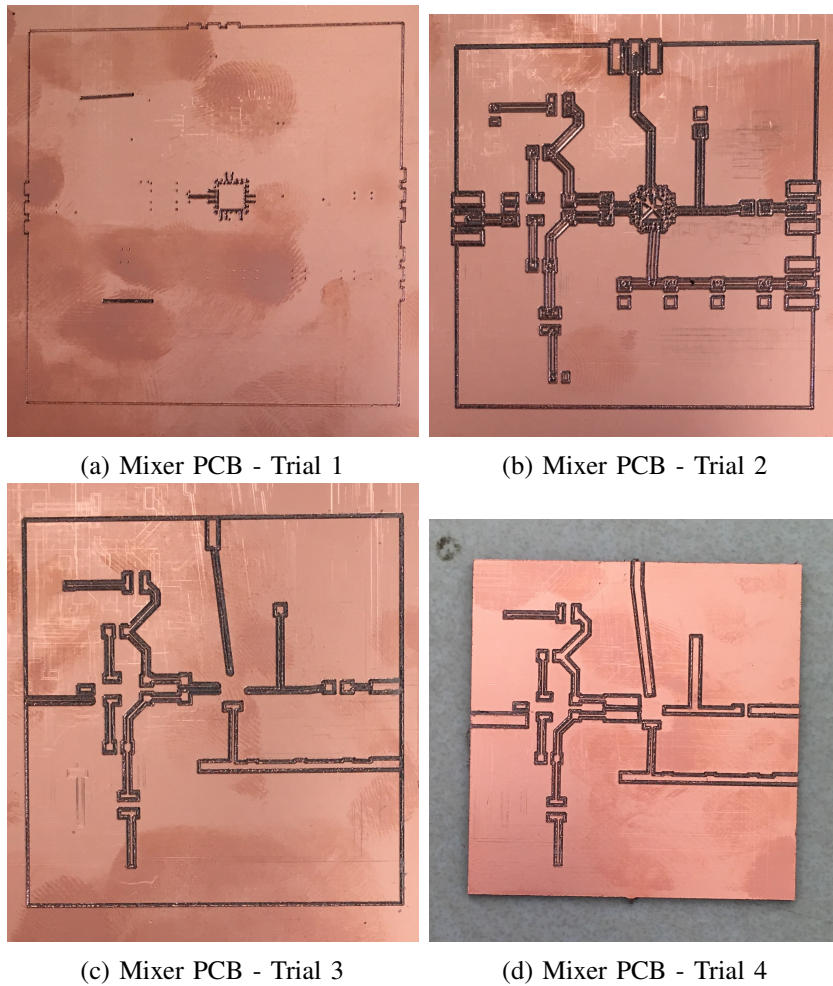

Fig. 8: Milling Machine Attempts

Trial 1, pictured in Fig. 8a, demonstrates how selected traces would be milled out. The following figures represent the rest of the learning process: attaining the whole circuit along with additional lines, first utilizing *Open Path* lines to outline Eagle traces (insufficient tracewidths, discontinuous), using *Open Path* lines with wider profiles to prevent trace discontinuity.

The IF (top port on the right edge of the board) needs a 70Ω transmission line. Linecalc in ADS was used to determine the line width needed is about 60 mil. The minimum trace width on the board design, 12 mil, is used for the mixer solder pads. Additionally, the distance between the mixer solder pads is about 14 mil. The milling machine can not mill these lines without compromising them (accurate up to 30 mil), so the design was sent to a board manufacturer. The gerber files for this board were sent to Bay Area Circuits to be manufactured with greater precision. Bay Area Circuits is capable of milling traces a minimum 6 mil width.

B. Using the Reflow Oven

The mixer printed circuit boards (PCBs) arrived on May 21 from Bay Area Circuits. On May 23 Jaime Carmo taught the project group how to use the ProtoFlow E reflow oven, shown in Fig. 9, in the Computer Engineering Society (CPES) club room. Project group proceeded to use the reflow oven to surface mount components to one mixer PCB. The mixer PCB was tested on May 24. Prior to mounting components, all trace connections were verified and the RF port was not connected to ground. After mounting the components and during testing, the RF port was probed and found to be connected to ground. The remainder of the mixer boards were checked and verified to have correct trace connections for all traces.



Fig. 9: ProtoFlow E Reflow Oven

Reflow Oven Operating Procedure

- 1) Prepare the PCB
 - a) Probe all traces and verify connections
 - b) Apply adhesive paste to all SMT pads
 - c) Add SMT components
- 2) Toggle on/off switch to ON position
- 3) Press right arrow key for ENTER function
- 4) Select appropriate board size using up and down arrow keys
- 5) Set oven support bars to width necessary to hold board
- 6) Press right arrow key for ENTER function
- 7) Allow machine to warm up until prompted by LCD screen
- 8) Open drawer and place board when prompted then close drawer

- 9) Wait time specified on LCD screen
 - a) Oven heats board to initial temperature of 170 *degrees C*
 - b) Temperature increases for reflow process
- 10) Open oven drawer when prompted and wait specified time to allow cool down
- 11) Carefully remove board
- 12) Close drawer and toggle on/off switch to OFF position

On May 25, the reflow oven was used to surface mount components to another mixer PCB. Prior to inserting PCB into reflow oven, all connections were checked via continuity probe to check for short circuits and none were found. The PCB was put in the reflow oven. Upon finishing, the PCB was rechecked via continuity probe. The RF and IF ports were grounded. It is unknown why, but it seems the reflow oven process is shorting random surface pads to ground. Jaime Carmo, Equipment Technician III and Electro-Mechanical Manager in the EE building, was asked if this as a recurring problem. He said the shorted leads was not a recurring problem, but that it was a possibility. He also gave advice regarding removal of the components which had already been re-flowed onto the board

The manufacturer was contacted and they replied that ESD might be the cause of the problem. The mixer will now be surface mounted using an ESD pad and grounding strap then retested. After careful consideration of the datasheets for the mixer, VCO, and amplifiers, the senior project group used a current limited power source to power these devices. The mixer and VCO work within specification of the datasheet.

VII. INTEGRATION AND RESULTS

The Biotrack Yagi-Uda antenna beamwidth and gain was verified by recording the E and H Co-Plane characteristics shown in Fig. 10. The directivity of the antenna is calculated using equation 7. From Fig. 10 it is seen that $HPBW_E = HPBW_H = 80degrees$. When input in the directivity equation, the result is 6.44 dB. The directivity is only 0.44 dB above the 6 dB gain given in the datasheet [8]. This indicates the antenna is not very lossy.

$$D = \frac{4\pi}{\omega_A} = \frac{41,253}{HPBW_E * HPBW_H} \quad (7)$$

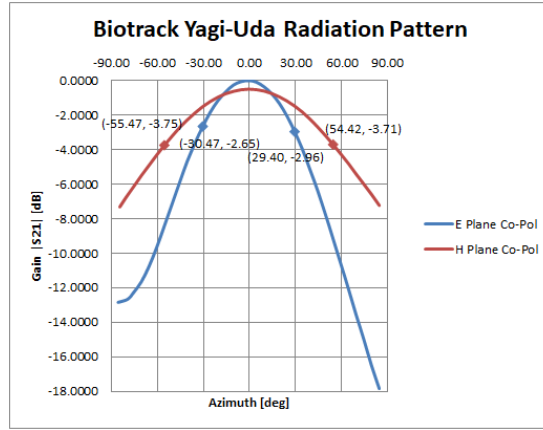

Fig. 10: Biotrack Yagi-Uda E and H Plane Beamwidth

The VCO and LDO controlling V_{tune} were integrated. The project group characterized the VCO and found V_{tune} needs to be 2.67 V to output the 3.235 GHz LO input. The VCO characterization results are shown in Table VII. VCO output power seen in this table is approximately 5 dB lower than the 5 dBm typical output power stated in the datasheet but is still within data sheet specifications [9]. The project group purchased additional amplifiers in case the output of the VCO could not drive the mixer's LO port. The LDO was designed with $V_{tune} = 2.67$ V to use VCO DUT 2 in the system. Using equation 8 from the LDO datasheet, surface mount resistors were used to tune the LDO [10].

$$V_{out} = V_{ADJ} \left(1 + \frac{R_2}{R_1} \right) - (I_{ADJ} * R_2) \quad (8)$$

$$V_{ADJ} = 0.6 \text{ V}$$

$$I_{ADJ} = 15 \text{ nA at } 25 \text{ degrees C}$$

These two modules were integrated and produced the output pictured in Fig. 11.

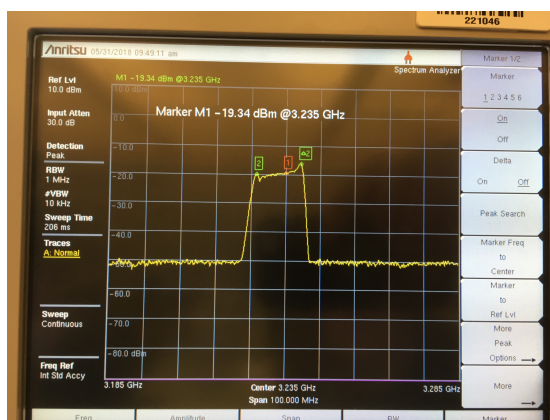

Fig. 11: Integrated VCO and LDO with LDO as the V_{tune} Input

The resulting VCO output contains greater noise than when tested with power supplies controlling both voltage inputs. The bandwidth is 12.9 MHz.

TABLE VII: VCO Characterization

	V_{CC} [V]	f_{out} [GHz]	V_{tune} [V]	Power Level [dBm]
DUT 2	3.021	3.235	2.67	-0.32
DUT 8	3.028	3.235	2.63	-0.40

Future projects need to finish integrating the rest of the system. Everything except the MAAL amplifier circuits work within specification at each device's operating frequency. If devices do not appear to work, make sure the power supply can source enough current. To fix problems encountered with the amplifiers further electrostatic discharge (ESD) precautions will be taken. These precautions consist of using rubber mats and grounding straps while handling and soldering the components. If the source of the defective amplifier circuits is not found, either the amplifiers were or circuit were defective.

VIII. CONCLUSION

This project has a long future ahead of it and has many aspects that can be improved. First and foremost, the communications system needs to be verified to see if signals transmit through the system when mounted on the ROV. With the current system, if the signal power arriving at the receive antenna is above -94.3 dBm, the transmit antenna should transmit a 3.4 GHz signal. Once the system design is verified, the 165 MHz receive antenna should be miniaturized so that the Aerospace Department can mount the antenna on either

the PUMA or NOVA. The components then need to be integrated together on a single board layout to further miniaturize the board, which is currently modular and spans a large area. The receive system for the 3.4 GHz system needs to be adjusted so the drone operator can receive intuitive feedback that will help guide the drone closer to the animal collar. Finally, software should be developed to make feedback more user friendly. All components have been given to Dr. Horney. He will give the results of this project to the next senior project group.

This senior project team had problems communicating with the Aerospace Department. Future senior projects should have a dedicated Aerospace Engineering student invested in the project or as a member of the senior project team to aid communication and offer guidance regarding how components will affect or be affected by the ROV. The affect of the component's weight on the ROV's center of gravity is a problem the Aerospace student could help minimize. Collaboration meetings between the disciplines is necessary to accurately design the system. Knowledge regarding limitations of the receiver system along with limitations of ROV alterations would help design the system to operate optimally on an ROV. The ROV alteration limitations consist of changes to center of gravity and payload weight limits. These limitations play a significant role in designing the receive antenna for use with the ROV as well as mounting the antenna on the ROV. Receiver system limitations consist of MDS, antenna gain, and effects of the ROV on the antennas radiation pattern. If more parts are needed to adjust the system, the senior project team should order them as free samples from Analog Devices HMC series.

APPENDIX A
SENIOR PROJECT ANALYSIS

Project Title: Remotely Operated Vehicle Animal Tracker

Student Names: Kevin Silken, Amanda Strand

Advisor's Name: Dean Arakaki

Summary of Functional Requirements:

A receiver system is mounted on a Remotely Operated Vehicle (ROV). The system consists of a receive antenna, amplifiers, mixer, voltage controlled oscillator (VCO), low drop out voltage regulators (LDO), battery supply, and transmit antenna. The system receives a 165 MHz signal from a fisher animal tracking collar, amplifies it, upconverts the signal to 3.4 GHz, and transmits the 3.4 GHz signal to a support ground team.

Primary Constraints:

Factors that inhibited project progress were lack of practical knowledge about RF systems and lack of communication with the Aerospace Department. During the first quarter of senior project, the team did not have any experience with wireless communications, antenna design, antenna limits, antenna mounting, or affects of additional equipment added to ROVs. This factor was partly alleviated by taking RF classes in wireless communications and antenna design during Winter and Spring quarters, 2018. The team is unclear on the best way to integrate the receiver system and ROV flight system but is working with the Aerospace Department to develop a solution. Lack of communication with the Aerospace Department is a constraint. The project stalled because there was disagreement on which ROV to use. Additionally, late in the project, new weight limits with greater constraints were defined for the PUMA, NOVA, and RMAX ROVs. This information eliminated using the PUMA ROV due to the decreased payload from the initial 5 lbs to 2 lbs. The project team should have convened a full meeting with the Electrical, Animal Science, and Aerospace Departments and discussed design constraints affecting every aspect of the system.

Economic:

- 1) Human capital is the collection of skills, knowledge, or other intangible assets of people that create economic value for the individuals, their employers, or their community. This project redistributes human capital from searching for animals to more suited jobs. Wildlife biologists would be able to

work on other projects and jobs are produced in the sales and drone support industries.

- 2) Financial capital is assets needed by a company to offer goods or services that are measured in terms of monetary value. This project costs financial capital to buy the parts needed to make a working system. Since this product is not set to be sold commercially, more financial capital is not needed to profit.
- 3) Natural capital is the world's stock of natural resources which includes mineral, soil, water, and living things. This project requires materials such as copper and semiconductor devices and therefore some of the earth's natural capital. At the cost of natural capital, human capital is conserved and can be re-purposed.
- 4) Costs: see Table VIII

Environmental: There are two main environmental considerations for this project. The first consideration is that mining and refining materials are toxic to the environment. Components are taken from the earth and used to build hardware such as the mixer and amplifiers. This process produces waste. The second consideration is that the project produces a smaller footprint while in use. Since the project is mounted on a drone that produces nearly no noise and flies high above the fishers, they are not intruded upon in their territory. This also has the benefit of preventing additional break down to the environment caused by foot traffic in the natural habitats.

Manufacturability: Board modules were either milled by a fabricator or obtained as evaluation boards from Analog Devices. The boards can not be milled on campus because the machines do not have the tolerance needed to mill the smallest trace widths or trace spacing. Current capabilities on campus are sub 20 mil.

Sustainability:

- 1) The greatest issue in maintaining the completed project is broken or worn out parts. If a component on one of the printed circuit boards breaks in the field, the broken part can not be easily replaced (while still in the field). ROV support teams also may not have the electrical test equipment needed to verify which module is defective. One way to minimize this issue is to have the system undergo stress testing before being used in the field.
- 2) This project has a negative impact on the sustainable use of resources. Semiconductor components such as mixers and amplifiers require industrial mining to be produced. This type of mining releases

toxic chemicals into the environment and can decrease the rate other sustainable resources regenerate.

- 3) There are upgrades that would improve this project. The 165 MHz antenna could be miniaturized to fit within the Aerospace Department's specifications. The system could become more compact by integrating all component modules (amplifiers, mixers, LDOs, etc.) on a single board. This would also reduce potential for broken parts due to the larger space needed to hold the modular boards.
- 4) Upgrading the design could be challenging. The first challenge is miniaturizing the 165 MHz receive antenna. The antenna is constrained by the dimensions set by the Aerospace Department. Additionally, when mounted on the ROV, the radiation pattern must encompass where the collars will be located, ie. towards the ground ahead of the ROV. An additional challenge is caused by integrating all the modules onto one board. The ROV support team needs to safely store these boards and needs to be trained in prevention of electrostatic discharge. The team would also need equipment to test if the system works after it is repaired.

Ethical: The main ethical concern is that hunters and poachers may use the tracking system to hunt and kill fishers wearing tracking collars. This is minimized because the tracking system is only for use by the United States Forest Service. Another concern is that aerial ROVs invade the airspace, but this means terrestrial creatures are not as affected. This is a benefit because using an aerial ROV compared to using humans decreases the total amount of time people invade wildlife habitats.

Health and Safety: While testing the system, the project team took appropriate electrostatic discharge measures to ensure the safety of the components. Another problem Dr. Horney, the Animal Science advisor, revealed was that people should be a suitable distance away from the ROVs during operation. One recounted accident was a helicopter ROV falling from about 80 feet high and crashing due to battery failure. In addition to the impact zone, shattered components may scatter and injure people in the surrounding area.

Social and Political: This project is pro environmental conservation because it contributes to less foot traffic in remote areas of nature. The project directly benefits wildlife biologists and indirectly benefits fishers. This project initially favors wildlife biologists over fishers because it immediately saves wildlife biologists time. Over time fishers benefit more because records are kept and humans can monitor if fishers are thriving or are negatively impacted without impacting the natural habitat of the fishers.

Development: Two new tools were used during the course of this project. The first tool was the anechoic chamber while the second tool was the milling machine. The anechoic chamber enabled the project team

to record antenna characteristics and extrapolate the gain of the receive antenna. The milling machine was initially used to fabricate the mixer board, but, because some of the line traces were too small, the boards had to be fabricated at a board manufacturer capable of milling as small as 6 mil tracewidths.

APPENDIX B
PARTS LIST AND COSTS

TABLE VIII: Bill of Materials

Part No.	Description	Distributor/Manufacturer	Price per Unit [\$]	Quantity	Total Price [\$]
HMC388LP4	3.15-3.40 GHz VCO Sample Boards	Analog Devices	0.00	2	0.00
LT3061EMS8E	1.6-45.0 V LDO Voltage Regulator	Mouser	3.39	5	16.95
LT5579IUH	1.5-3.8 GHz Mixer	Mouser	12.02	6	72.12
MABAES0061	2-800 MHz Audio Transformer	Mouser	2.03	2	4.06
MAAL-010704	0.1-3.5 GHz LNA	Richardson RFPD	1.47	10	14.70
132322	50Ω, 62 mil SMA End Launch Connector	Amphenol Connex	6.09	20	121.80
441 [Product ID]	0805 SMT 5% Resistor and Capacitor Book	Adafruit Industries	39.95	1	39.95
TS391SNL	15 g Solder Paste	Mouser	16.95	1	16.95
Circuit Board	FR-4 PCB	Bay Area Circuits	49.61	3	148.83
Yagi-Uda Antenna	165 MHz Antenna	Lotek	315.00	2	630.00
Animal Collar	160-170 MHz Animal Tracking Collar	Lotek	1690.00	1	1690.00
Sum Total					2755.36

APPENDIX C
PC BOARD LAYOUT

This mixer PCB layout follows the LT5579 Evaluation board schematic and is provided in the datasheet [6]. The design is set for IF input frequency between LF and 1.00 GHz, LO input frequency between 0.75 GHz to 4.30 GHz, and output RF frequency between 0.90 GHz and 3.90 GHz. According to the manufacturer, LF stands for Low Frequency and usually indicates a minimum frequency around 0.10 GHz. The typical V_{cc} is 3.3 V and the supply current is 226 mA.

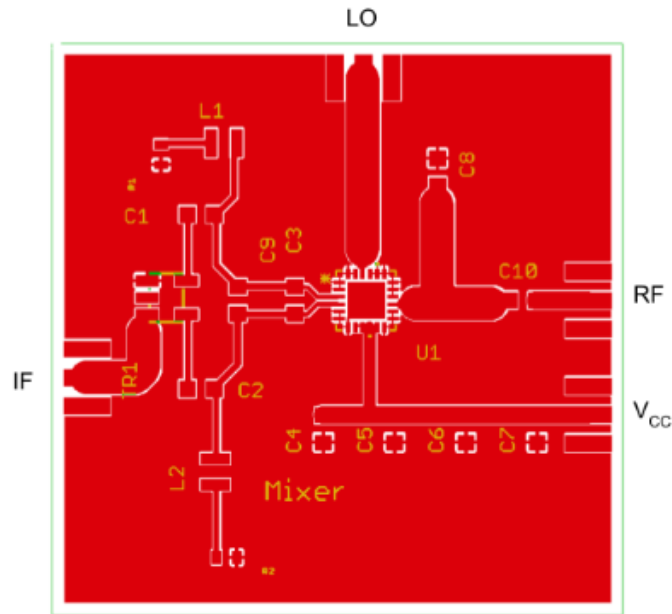

Fig. 12: Mixer PCB Layout

This low-noise amplifier (LNA) PCB layout follows the MAAL-010704 Evaluation board schematic and is provided on p. 10 in the datasheet [11]. According to Macom, the manufacturer of the PCB, this layout can be used for the IF, LO, and RF frequencies set by the mixer with changes to passive component values. The typical supply voltage is 3 V and the supply current is 60 mA.

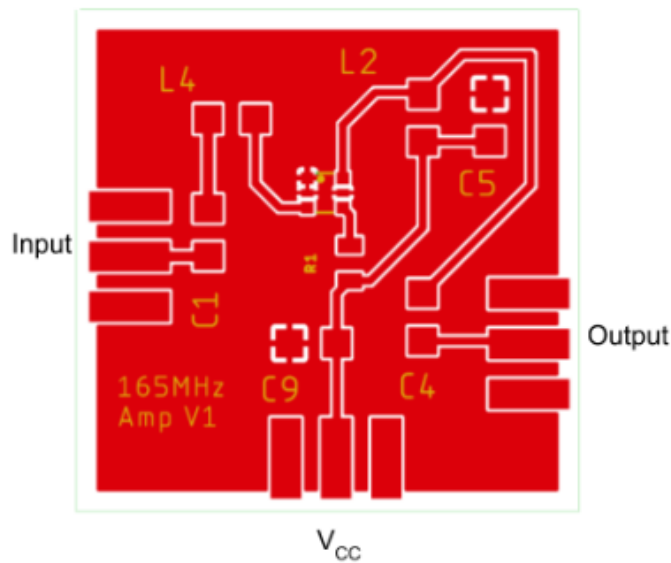

Fig. 13: LNA PCB Layout

This low dropout voltage regulator (LDO) PCB layout follows the LT3061 Evaluation board schematic

and is provided in the datasheet [10]. The input voltage can range between 1.6 V and 45 V and can output between 0.6 V and 19 V. The maximum input current is 102 mA while the typical output current is 100 mA. One LDO can power each of the components except for the mixer, which requires three LDOs in parallel to supply up to 300 mA.

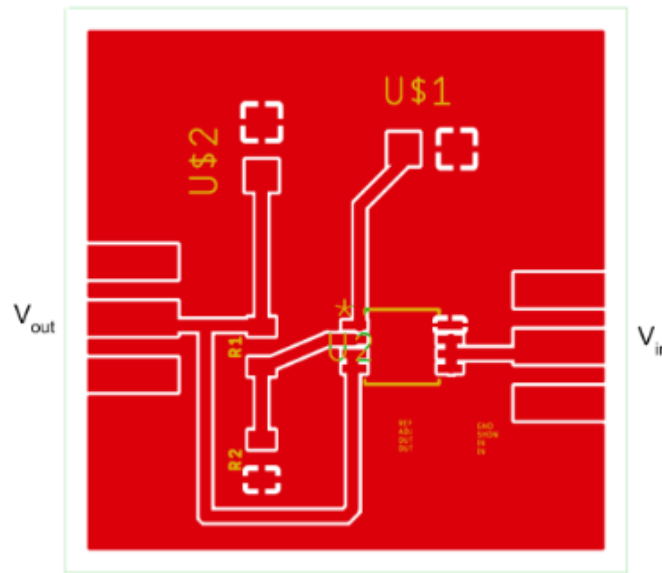

Fig. 14: LDO PCB Layout

APPENDIX D

HARDWARE CONFIGURATION/LAYOUT

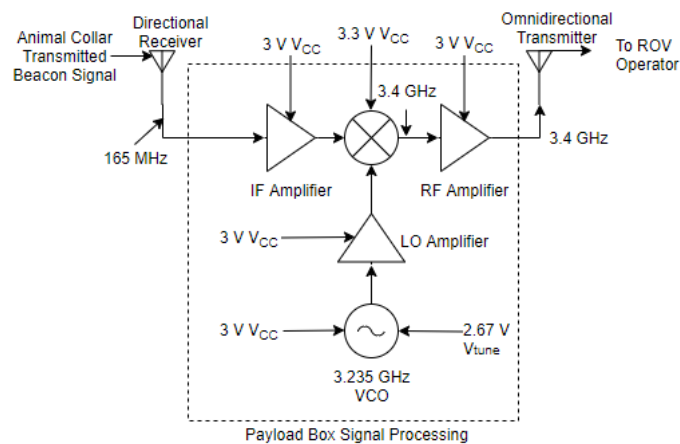
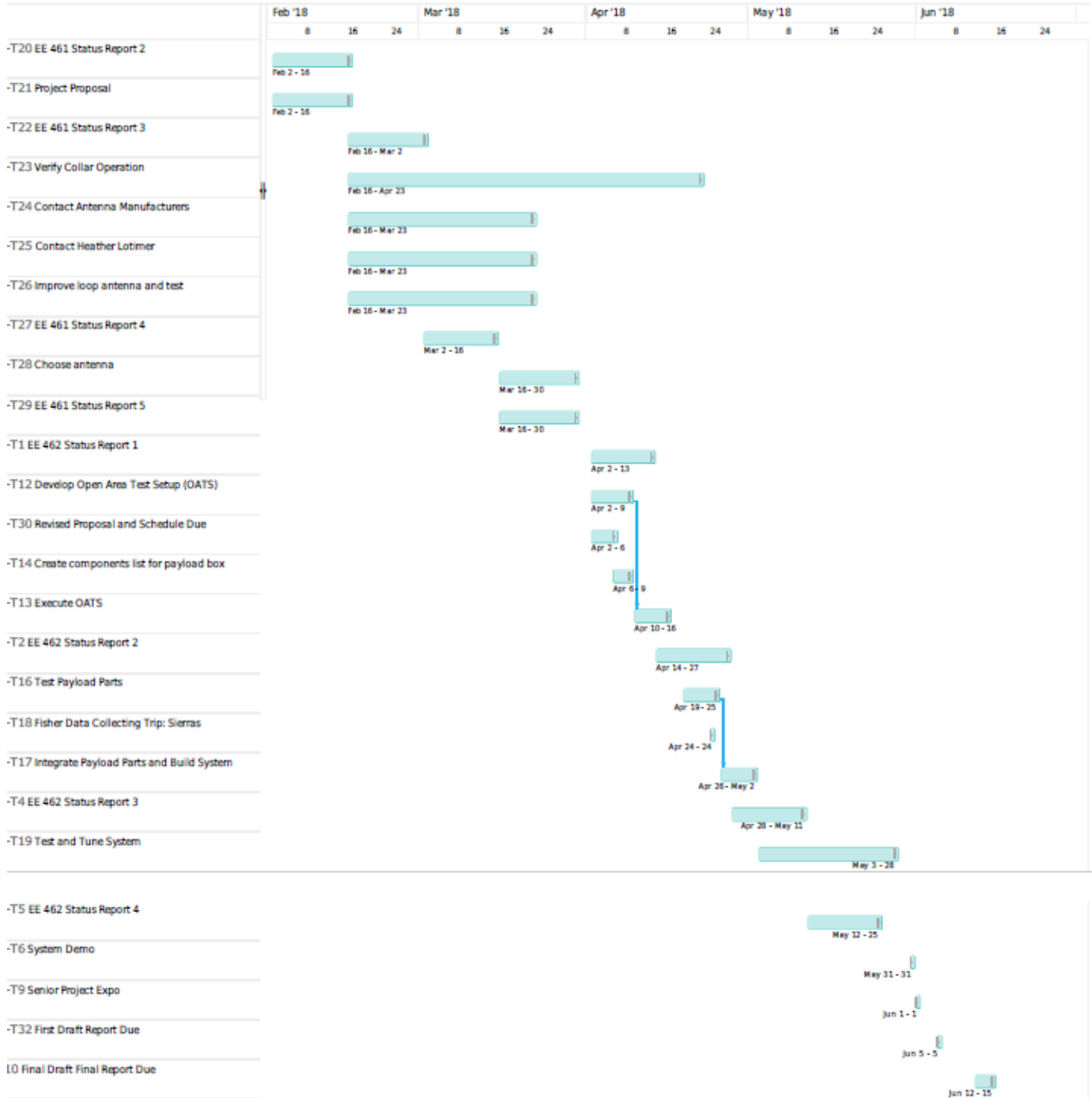

Fig. 15: Level 1 Block Diagram

APPENDIX E

SCHEDULE - TIME ESTIMATES

Senior Project Gantt Chart



Task notes:

Contact Antenna Manufacturers: Ask about antenna recommendations.

Contact Heather Lotimer: Request information about Biotrack Yagi-Uda antenna.

Improve loop antenna and test: Create a better match by adjusting the spacing between ends of the loop as well as radius of the loop.

Choose Antenna: Determine which of potential antennas works best for the system.

Test Payload Parts: Verify components operate within datasheet specifications as they are received.

Integrate Payload Parts and Build System: Run further verification tests to ensure components integrate with each other correctly in the designed layout.

Test and Tune System: Make any necessary adjustments to passive component values to attain designed operation.

REFERENCES

- [1] Movebank. (Jun. 2018). What is Animal Tracking? [Online]. Available: <https://www.movebank.org/node/857>.
- [2] *450 to 470 MHz Mobile Magnetic Mount 1/4 Wave Antenna with 3.2 dBi Gain and TNC Plug Male Connector*, ANMM4X03, AIR 802, 2012.
- [3] *LiteTrack Collars*, LiteTrack 40/60, Sirtrack, Aug. 2016.
- [4] IBCrazy. (Apr. 2018). 3.4 GHz LHCP Airblade Antenna Set, [Online]. Available: <https://www.getfpv.com/ibcrazy-3-4ghz-lhcp-airblade-antenna-set.html>.
- [5] D. Pozar, *Microwave and RF Design of Wireless Systems*. New York, NY: John Wiley and Sons, 2001.
- [6] *1.5 GHz to 3.8 GHz High Linearity Upconverting Mixer*, LT5579, Rev. A, Linear Technology, Jun. 2010.
- [7] (May 2018). Online Gerber-Viewer, PCB-Investigator, [Online]. Available: <http://www.gerber-viewer.com/>.
- [8] *Yagi Antennas*, LT5579, Biotrack, Jan. 2018.
- [9] *MMIC VCO w/ Buffer Amplifier, 3.15 - 3.4 GHz*, HMC388LP4, Rev. 02, Analog Devices, May 2008.
- [10] *45V, Micropower, Low Noise, 100mA LDO*, LT3061, Rev. B, Analog Devices, Nov. 2017.
- [11] *Low Noise Amplifier 0.1-3.5 GHz*, MAAL-010704, Rev. V4, Macom.