

**INVESTIGATION OF ORTHOGONAL FREQUENCY
DIVISION MULTIPLEXING BASED POWER LINE
COMMUNICATION SYSTEMS**

ALI HOSSEINPOUR

**A thesis submitted in partial fulfilment of the requirements for the degree
of Doctor of Philosophy at the School of Architecture Computing &
Engineering, University of East London**

February 2015

Abstract

Power Line Communication (PLC) has the potential to become the preferred technique for providing broadband to homes and offices with the advantage of eliminating the need for new wiring infrastructure and reducing the cost. Power line grids, however, present a hostile channel for data communication, since the fundamental purpose of the power line channel was only the transmission of electric power at 50/60 Hz frequencies. The development of PLC systems for providing broadband applications requires an adequate knowledge of the power line channel characteristics. Various types of noise and multipath effects are some of the limitations for power line channels which need to be considered carefully in designing PLC systems. An effect of an impulsive noise characterized with short durations is identified as one of the major impairment in PLC system. Orthogonal Frequency Division Multiplexing (OFDM) technique is one of the modulation approaches which has been regarded as the modulation technique for PLC systems by most researchers in the field and is used in this research study work. This is because it provides high robustness against impulsive noise and minimizes the effects of multipath. In case of impulsive noise affecting the OFDM system, this effect is spread over multiple subcarriers due to Discrete Fourier Transform (DFT) at the receiver. Hence, each of the transmitted communication symbols is only affected by a fraction of the impulsive noise. In order to achieve reliable results for data transmission, a proper power line channel with various noise models must be used in the investigations. In this research study work, a multipath model which has been widely accepted by many researchers in the field and practically proven in the Tanzanian power line system is used as the model for the power line channel.

The effects of different scenarios such as variations in direct path length, path number, branch length and load on the channel frequency response are investigated in this research work. Simulation results indicate the suitability of multi-carrier modulation technique such as an OFDM over the power line channels. To represent the actual noise scenario in the power line channel, an impulsive noise and background noise are classified as the two main noise sources. A Middleton class A noise is modelled as an impulsive noise, whereas the background noise is modelled as an Additive White Gaussian Noise (AWGN). The performance of PLC system based on OFDM is investigated under Middleton Class A and AWGN noise scenarios. It is observed that Bit Error Rate (BER) for the impulsive noise is higher than the background noise. Since channel coding can enhance the transmission in a communication system, Block code and convolutional codes have been studied in this research work. The hamming code chosen as a type of the block code, whereas the Trellis Coded Modulation (TCM) selected from the category of the convolutional channel codes and modelled in Matlab2013b. Although TCM code produces improvements in the Signal-to-Noise Ratio (SNR), they do not perform well with Middleton class A noise. A rectangular 16-QAM TCM based on OFDM provides better BER rate compared to the general TCM.

Keywords

AWGN, block codes, Bit Error Rate (BER), convolutional coding, data transmission, Hamming code, Impulsive noise, Middleton Class A noise, multicarrier modulation, orthogonal frequency division multiplexing (OFDM), power line channel, Power line communications (PLC), Quadrature Amplitude Modulation (QAM), rectangular 16-QAM TCM, Trellis Coded Modulation (TCM).

Preface

Advances in digital communications technologies have made it possible to access high speed Internet by simply plugging your electronic digital devices to the wall socket in your home. PLC technology exploits the widespread electric power infrastructure to provide broadband services to and within the home or office.

This research study is the result of my study work as a post graduate student at School of Architecture, Computing and Engineering (ACE) at University of East London (UEL). Parts of this thesis have been presented/accepted at conferences are:

- Hosseinpournajarkolaei,A, Lota,J, Hosny,W. (2015). *Bit Error Rate Performance in Power Line Communication Channels with Impulsive Noise*. IEEE International Conference on Mathematical/Analytical Modelling and Computer Simulation, AMSS 17th, Cambridge University (Emmanuel College), UK.
- Hosseinpournajarkolaei,A, Jahankhani,H, Hosseinian-Far,A. (2013) *Vulnerability Considerations for Power Line Communication's (PLC) Supervisory Control and Data Acquisition*. Int. J. Electronic Security and Digital Forensics, Vol. 6 No. 2,pp.104-114. July 2014.
- Hosseinpournajarkolaei,A, Lota,J, Hosny,W. (2012) *Challenges Facing The Design of Broadband Power Line Communication (BPLC) systems*, IEEE conference in Power Engineering, 47th UPEC 2012, Brunel University of London.

- Hosseinpournajarkolaei, A. Hosseinian-Far, A. (2012) *Channel Characterization for Broadband Power Line Communication System*. 6th SASTech Intl. Symposium, KL, Malaysia.
- Hosseinpournajarkolaei,A, Lota,J, Hosny,W. (2012) *Design of Broadband Power Line Communication system for UK Power line system* , AC&T 2012,University of East London.

Under progress Journal paper:

- Hosseinpournajarkolaei,A, Lota,J, Hosny,W. (2015). *Modeling and Analyzing Trellis Coded Modulation on Power Line Communication Systems*. On progress to be submitted for at IEEE journal.

These papers correspond to the work presented in Chapter 3 and 4 were done during my Ph.D. at University of East London. Results in chapter 5 are in progress to be submitted as an IEEE journal.

The thesis starts with a quick introduction to PLC system followed by some literatures in the field and ends with conclusions and some further works.

Reviewed publication:

The author served as a reviewer for the following journal:

- International Journal of Numerical Modelling: Electronic Networks, 2014

Ali Hosseinpour
2015

Table of Contents

ABSTRACT	I
KEYWORDS	III
PREFACE	IV
LIST OF FIGURES.....	VIII
LIST OF TABLES.....	XII
ABBREVIATIONS	XIII
ACKNOWLEDGMENT	XV
DEDICATION	XVI
CHAPTER 1.....	1
INTRODUCTION	1
1.1. <i>Background and Motivations</i>	1
1.2. <i>Power line distribution systems</i>	4
1.3. <i>Digital communications</i>	6
1.4. <i>Thesis Objectives</i>	9
1.5. <i>Summary</i>	15
1.6. <i>Thesis Organization</i>	15
CHAPTER 2.....	19
LITERATURE REVIEW.....	19
2.1. <i>Introduction</i>	19
2.2. <i>Power Line Communications</i>	20
2.3. <i>Characteristics of power lines</i>	36
2.4. <i>Power line communication access network</i>	42
2.5. <i>Applications of power line communication</i>	54
2.6. <i>Modulation techniques over PLC</i>	58
2.7. <i>Different types of noises effecting PLC</i>	66
2.8. <i>Channel coding and error correction</i>	67
2.9. <i>Transformers</i>	76
2.10. <i>Electromagnetic compatibility of PLC systems</i>	77
2.11. <i>Security of power line communication</i>	78
2.12. <i>Feasibility of power line communication</i>	79
2.13. <i>Summary</i>	80
CHAPTER 3.....	82
DATA TRANSFER OVER POWER DISTRIBUTION NETWORKS	82

3.1.	<i>Introduction</i>	82
3.2.	<i>Transmission line model</i>	83
3.3.	<i>Power distribution networks</i>	84
3.5.	<i>Simulation results</i>	86
3.6.	<i>Summary</i>	93
CHAPTER 4		94
	BIT ERROR RATE PERFORMANCE IN POWER LINE COMMUNICATION CHANNELS WITH IMPULSIVE NOISE	94
4.1.	<i>Introduction</i>	94
4.2.	<i>Impulsive noise modelling</i>	96
4.3.	<i>BER performance in PLC under an impulsive noise</i>	104
4.4.	<i>Summary</i>	110
CHAPTER 5		112
	DATA TRANSFER IMPLEMENTED BY TRELLIS CODED MODULATION ON PLC BASED OFDM	112
5.1.	<i>Introduction</i>	112
5.2.	<i>Trellis Coded Modulation (TCM)</i>	113
5.3.	<i>System model</i>	116
5.4.	<i>Summary</i>	126
CHAPTER 6		127
	VALIDATION, DISCUSSIONS AND CRITICAL ANALYSIS	127
6.1.	<i>Introduction</i>	127
6.2.	<i>Interpretation and reporting</i>	127
6.3.	<i>Critical analysis and validations</i>	128
CHAPTER 7		139
	CONCLUSIONS AND FURTHER RESEARCH.....	139
7.1.	<i>Summary of the results</i>	140
7.2.	<i>Suggestion for further Works</i>	143
REFERENCES		144
	APPENDICES	155
	<i>MATLab codes</i> :.....	157

List of Figures

Figure 1.1.	Available modulation approaches	3
Figure.1.2.	Overview of End-to-End Access PLC System	6
Figure.1.3.	A digital communication system for the power line channel	7
Figure.1.4.	Impairments present on the power line	8
Figure.1.5.	A simplified model of the power line channel	8
Figure.1.6.	PLC operating bands in Europe	9
Figure.1.7.	PLC model for this research study work	10
Figure.2.1.	General structure of a PLC system for energy related services	21
Figure.2.2.	Power Line Communications network	30
Figure.2.3.	LV PLC access network	32
Figure.2.4.	The influence of various disturbance sources	33
Figure.2.5.	Shared transmission medium in PLC access network	35
Figure.2.6.	Typical topology of power line transmission line	40
Figure.2.7.	A multipath propagation data from A-C	40
Figure.2.8.	Multipath PLC channel model	42
Figure.2.9.	The typical PLC access network	43
Figure.2.10.	Structure of a PLC in-home network	46
Figure.2.11.	Functions of the PLC modem	47
Figure.2.12.	Function of typical PLC base station	48
Figure.2.13.	A function of PLC repeater	49
Figure.2.14.	PLC network with repeater	50
Figure.2.15	Subscriber connection over gateway	52

Figure2.16.	Direct connection of the PLC subscriber	52
Figure 2.17.	Gateway in the PLC access network	53
Figure.2.18.	The Smart Metering System	56
Figure.2.19.	PLC with different system architecture	58
Figure.2.20.	OFDM transmitted signal	60
Figure.2.21.	Realisation of an OFDM system	61
Figure.2.22.	OFDM transmitter configuration	64
Figure.2.23.	OFDM receiver configuration	65
Figure.2.24.	Classification of noise in PLC	67
Figure.2.25.	The main FEC classes: block codes and convolutional code	70
Figure.2.26.	An alternative description of the Hamming code	72
Figure.2.27.	The generic turbo encoder	73
Figure.2.28.	General TCM system with various code rate and out puts	75
Figure.3.1.	Elementary cell of a transmission line	83
Figure.3.2.	A simple LV Power Line network configuration	85
Figure.3.3.	Topology of sample network	86
Figure.3.4.	Frequency response for LV channel, effect of the direct length from transmitter to receiver (AC varies as 100m,200m,400m,800m) , $Z_L=Z_s=50\Omega$.	89
Figure.3.5.	Frequency response for the LV channel with one branch; effect of varying the length of AC with one branch BD of 20m. AC varies as 100m, 200m, 400m, 800m.	90
Figure.3.6.	Variation in the frequency response for the LV voltage channel with change in branch of length.	91
Figure.3.7.	Variation in the LV channel frequency response with change	92

in branch from 40Ω to 80Ω .

Figure.3.8.	Multipath channel model with number of path=4	92
Figure.3.9.	Multipath channel model with number of path=10	93
Figure.4.1.	a) An unit-area pulse (b) The pulse transforms into an impulse since $\epsilon \rightarrow 0$; (C) The spectrum of the impulsive function.	96
Figure.4.2.	Pdf of the impulsive noise with impulsive index $A=0.01$	102
Figure.4.3.	Pdf of the Middleton Class A noise with impulsive variable index A	103
Figure.4.4.	Pdf of the Middleton Class A variable Γ	103
Figure.4.5.	The PLC model	105
Figure.4.6.	Diagram of an OFDM system consisting of a transmitter, a PLC channel and a receiver	107
Figure.4.7.	Illustrates the input signal Vs output affected by AWGN and Impulsive noise	107
Figure.4.8.	BER Vs SNR for different value of index (A) of Middleton Class A for the PLC channel	108
Figure.4.9.	SNR Vs BER for multipath PLC channel	109
Figure.4.10.	Input signal to the channel Vs output with the effect of AWGN	109
Figure.4.11	Illustrates the input signal affected by an Impulsive noise	110
Figure.5.1.	A rate 2/3 convolutional encode	114
Figure.5.2.	Trellis Coded Modulation	115

Figure.5.3.	Rectangular 16-QAM TCM	116
Figure.5.4.	System model with rectangular 16-QAM TCM	117
Figure.5.5.	The schematic of OFDM modulation	119
Figure.5.6.	OFDM symbol; a) without cyclic prefix, and b) with cyclic prefix	120
Figure.5.7.	Schematic of OFDM demodulator	123
Figure.5.8.	Decoding of rectangular QAM TCM	124
Figure.5.9.	Simulation results for TCM and rectangular QAM TCM	125
Figure.6.1.	Phase response for a typical power line link one branch (a) 4 Km, (b) 2 Km, (c) 1 Km, (d) 500m.	129
Figure.6.2	Simulation results for a typical channel of 4 Km with one branch of length (a) 10, (b) 20, (c) 40 and (d) 80m	130
Figure.6.3.	Performance of the PLC system with different load impedances	131
Figure.6.4	BER of OFDM/64QAM over power line and AWGN channel	135
Figure.6.5.	BER Vs SNR comparison of TCM and Convolutional	138

List of tables

Table.2.1.	CENELEC bands for power line communications	32
Table.3.1.	Model Parameters of the transfer function	86
Table.3.2.	Signal propagation paths of the examined network	88
Table.5.1.	Proposed system parameter set	121

Abbreviations

AHP:	Analytic Hierarchy Process
ASK:	Amplitude Shift Keying
ATP-EMTP:	Alternative Transient Program - Electromagnetic Transient Program
AWGN:	Additive White Gaussian Noise
BER:	Bit Error Rate
BPL:	Broadband Power Line
BPSK:	Binary Phase Shift Keying
CDMA:	Code Division Multiple Access
CISPR:	Comite International Special des Perturbations Radioelectriques
CP:	Cyclic Prefix
DSL:	Digital Subscriber Lines
dB:	Decibel
ETSI:	European Telecommunications Standards Institute
FSK:	Frequency Shift Keying
FFT:	Fast Fourier Transform
GI:	Guard Interval
HV:	High Voltage
IDFT:	Inverse Discrete Fourier Transform
IFFT:	Inverse Fast Fourier Transform
ISI:	Inter Symbol Interference
IV:	Indoor Voltage
LLC:	Logical Link Control

LV:	Low Voltage
MAC:	Medium Access Control
MAP:	Maximum A posteriori Probability
MCM:	Multilevel Coded Modulation
MHz:	Mega Hertz
MLL:	Maximum Log Likelihood
MMSE:	Minimum Mean Square Error
MV:	Medium Voltage
OFDM:	Orthogonal Frequency Division Multiplexing
OSI:	Open Systems Interconnection
PAM:	Pulse Amplitude Modulation
PEP:	Pairwise Error Probability
PLC:	Power Line Communications
Pdf:	Probability Density Function
PSK:	Phase Shift Keying
QAM:	Quadrature Amplitude Modulation
QPSK:	Quadrature Phase Shift Keying
SISO:	Soft-Input Soft-Output
SNR:	Signal to Noise Ratio
SP:	Set Partitioning
TCM:	Trellis Coded Modulation
WLAN:	Wireless Local Area Networks
WLL:	Wireless Local Loop

Acknowledgment

This project is by far the most significant accomplishment in my life and it would be impossible without people who supported me and believed in me.

It is a pleasure to thank those who made this thesis possible. I would like to express my deepest gratitude to my senior supervisor Dr Wada Hosny from department of Architecture Computing Engineering (ACE) for his intensive supervision, guidance and trust through my candidature at the University of East London. His door was always open for his PhD students during his time at UEL University and his energy and enthusiasm in research has been a major source of motivation.

My sincere appreciation is extended to Dr. Jaswinder Lota who was my co-supervisor through my PhD candidature. His knowledge and priceless advices have largely contributed in finding my way through the research world. Without his support and inspirations, this thesis would likely not have matured.

I would like to thank all my friends for all the thoughtful and mind stimulating discussions we had. I have enjoyed their companionship so much during my stay at the University of East London.

Last but not least I would like to express my gratitude to my beautiful wife, my lovely parents and also My uncle, Mr Abdullah Hosseinpour, whose love and encouragement have supported me throughout my education. Particular mention goes to my wife for improving on my best by doing her best. I love you all.

Dedication

I would like to dedicate this Doctoral dissertation to my lovely parents and my kind and beautiful wife. There is no doubt in my mind that without their constant loves, endless supports and encouragements I could not have completed this process.

ماحصل آموخته هایم را تقدیم می کنم به آنان که مهر آسمانی شان آرام بخش آلام
زمینی ام است
به استوارترین تکیه گاهم، دستان پرمهر پدرم
به سبزترین نگاه زندگیم، چشمان سبز مادرم
به همسرم؛ که سایه مهربانیش سایه سار زندگیم می باشد، او که اسوه صبر و تحمل
بوده و مشکلات مسیر را برایم تسهیل نمود.
که هرچه آموختم در مکتب عشق شما آموختم و هرچه بکوشم قطره ای از دریای بی
کران مهربانیتان را سپاس نتوانم بگویم
امروز هستی ام به امید شماست و فردا کلید باغ بهشتم رضای شما
بوسه بر دستان پرمهرتان

Chapter 1

Introduction

1.1. Background and Motivations

Demand for broadband multimedia applications has been rising significantly in the past few years, and is still growing. Broadband internet access has now become a necessity for businesses and homes and is highly in demand. There are a lot of communication technologies that are used for broadband connectivity in homes and offices. Among those communication technologies, power line communications (PLC) appears to be a preferred multimedia connectivity solution and receives a huge amount of research interest by the researchers.

PLC exploits the power line infrastructure to provide high-speed broadband to customers. Hence a PLC system does not require new wiring installation in the building which is a great cost saving. The concept of using power line for communication services is not one that has just emerged recently. The first application of PLC in fact was used hundred years back when analogue communications were used for home automation and remote metering. Hence, the power supply utilities were required to have a stable communication link to maintain the operation of high voltage power lines. The attention, however, has shifted to the PLC technology for the purpose of high-speed internet access and various other services of broadband multimedia in the past decade (Cacciaguerra, 2003).

Although there are various advantages of the PLC, the power line channel was actually never designed for data transmission. There are essential structural and physical differences between the power lines and the other communication channels such as a coaxial cables and fibre optics. Therefore, it is important to understand these properties in order to design PLC systems (Dostert, 2001).

Multipath affects, attenuation and noise are the most significant factors affecting communications over power lines. Power line cables suffer from frequency-dependent attenuation. This attenuation increases with high frequencies and can be severe for long distance communications. Signal reflection is caused by impedance mismatching which increases the multipath fading. The noise that is produced by various appliances that are connected or linked to PLC transmission channel, is one more impairment found in PLC systems. The noise that comes at from the power outlet (plugs or sockets) is basically the noise produced by various appliances that are connected to the line. There are five common noises that can be found in the power line channels. They are narrowband noise, periodic impulsive noise asynchronous to the main frequency, coloured background noise, periodic impulsive noise synchronous to the main frequency and asynchronous impulsive noise. Coloured background noise, narrowband noise, periodic impulsive noise asynchronous to the mains frequency are known as background noise, while the other are known as impulsive noise.

An impulsive noise is a created from switching transients in power appliances. These impulses are of short durations with high amplitudes. The Power Spectral Density (PSD) of such noise can reach up to 50dB higher than that of the background noise.

Because of the impulsive noise as well as other interference characteristics of power line grids, it is important that a suitable modulation technique is selected for the PLC system. There are various available modulation techniques, Figure 1.1, such as a Multi Carrier Modulation (MCM), single carrier and spread spectrum modulation. An MCM technique such as an OFDM is a modulation technique of choice for PLC systems because of having better performance in comparison with a single carrier modulation and its performance in impulsive noise environments.

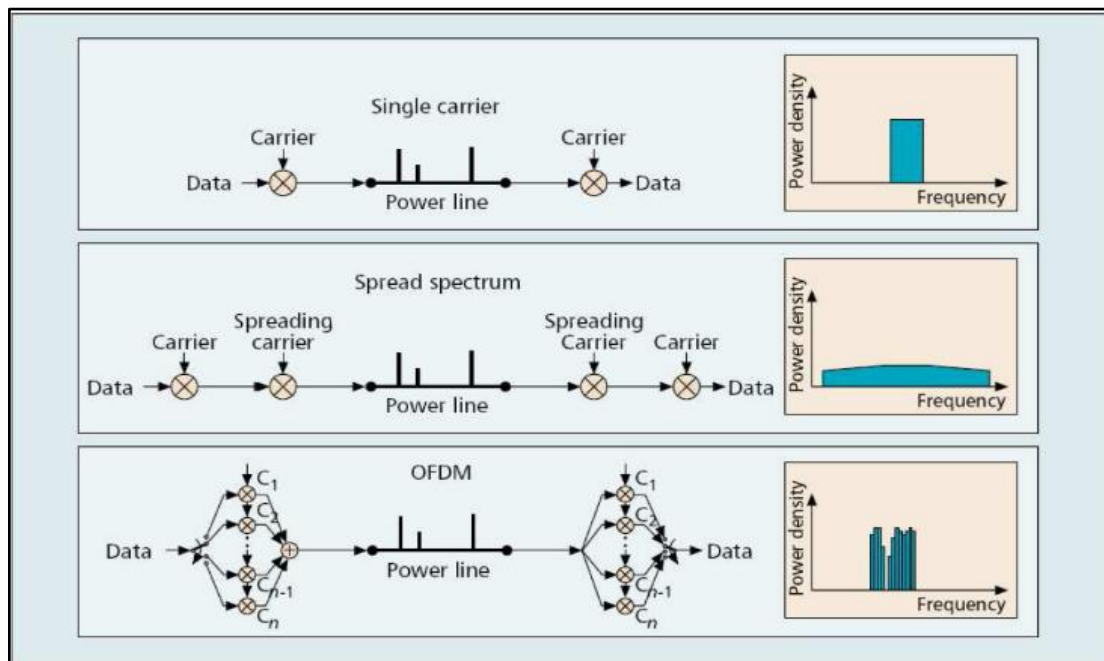

Figure.1.1. Available modulation approaches (Gotz, et al., 2004)

The problem of multipath can be eliminated by adding a cyclic time guard as it can be more discussed in later chapters. Furthermore, the influence of impulsive noise is also reduced because the received OFDM signal with added noise is divided by the number of sub channels through the discrete Fourier transform operation in the receiver (Biglieri & Toino, 2003).

Forward Error Correction (FEC) can be utilized to improve the reliability of the data transmission systems. To tackle errors caused by burst disturbance and

make the system more efficient, interleaving is required because of the occurrence of impulsive noise in the power line channels.

As it has been discussed earlier, the impulsive noise has more effects on the PLC system than any other sort of noises. A considerable performance degradation can occur in OFDM based PLC, due to the high power impulsive noise. Hence, it is very important to investigate its influence on data communications. There is also a need to bring ways that can limit its damage and enhance PLC performance in severe environments.

The focus of this research study is on the power line as a communication channel with the aim to improve the performance of the current PLC system with the use of an OFDM and FEC techniques. This objective is achieved by first tackling the problem of impulsive noise and presenting ways of limiting its effect on communication signals. Secondly, the research work includes the application of suitable methods of modulation and FEC channel coding techniques that, as will be demonstrated here, increase the reliability of PLC systems as well as maximizing the data rate.

1.2. Power line distribution systems

A power plant generates the electric power, then transports it through High Voltage (HV) cables to Medium Voltage (MV) substations. The substations transform the Medium Voltage into Lower Voltage (LV) and then distributes it to a large number of LV grids. Typical voltage values for HV, MV and LV transmission lines respectively, are 425 KV, 33 KV and 11 KV.

Every LV grid contains one substation. This substation delivers the voltage, which is transformed into 400V line voltage, to all the households that are connected through LV lines. PLC works through electrical signals. These

signals carry information over the power line. A communication channel can be explained as a physical path that exists between two communicating nodes.

The type of communication that takes place through the power line channels determines the quality of the channel. The channel quality is generally a factor of the level of the noise at the receiver and the attenuation of the electrical signal at different frequencies. It is harder to detect the received signal when the noise level is high due to possible interrupted signals. If the signals get attenuated on their ways to the receiver, the quality of the channel deteriorates further due to the fact that the signal gets more hidden by the existing noise.

The noise on the power line is generated by every load (electrical devices), which is linked to the grid. The power line is considered as a very harsh environment due to the time variant attributes of the noise and the attenuation. However, this also prevails in most communication systems and limits the performance that can be achieved.

PLC systems comprise different components which function together to provide internet connectivity services to consumers in their houses, offices or buildings. The data is carried by either fibre optic or telephone lines to avoid HV transmission power lines. As it is illustrated in Figure.1.2. the data is injected onto the MV power distribution grid and special electronic devices, known as repeaters, re-amplify and re-transmit the signal because the signal loses strength as it travels along the MV power line. Other technologies are used to detour the signal around transformers.

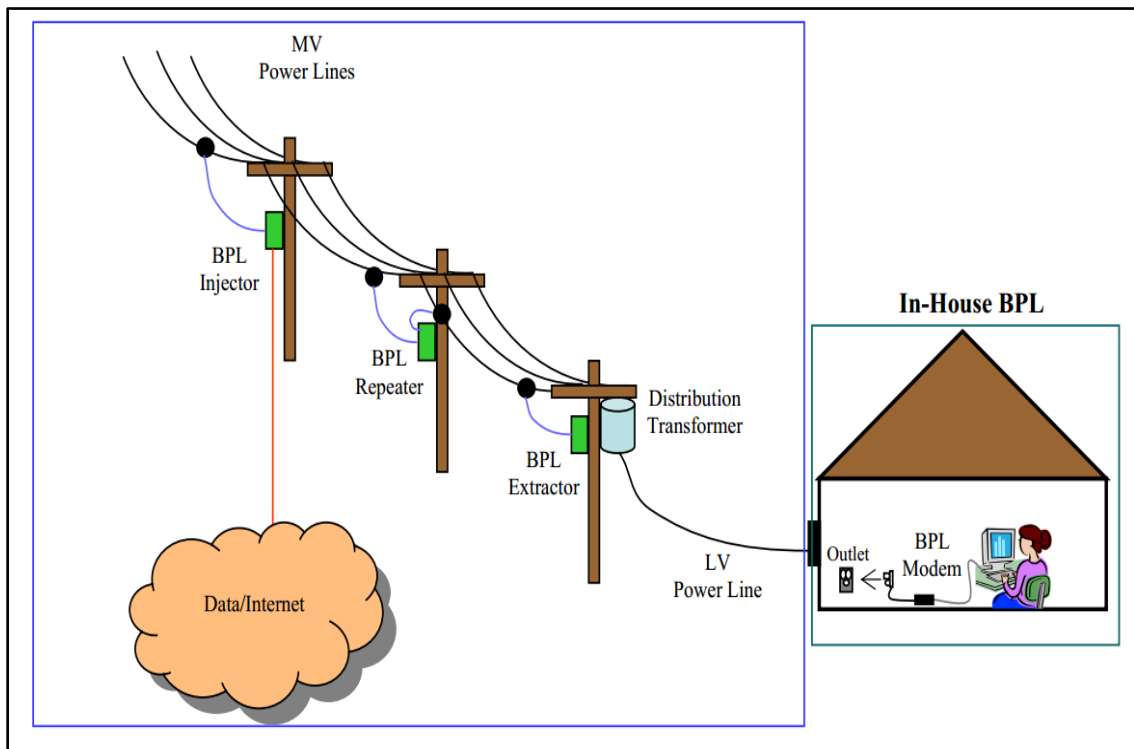

Figure.1.2. Overview of End-to-End Access PLC System (SMSE, 2005)

An Access PLC system uses either a combination of LV and MV power lines or LV power lines only. It also uses repeaters, injectors and extractors to deliver internet service to customers. In this case the Broadband Power Line (BPL) (another name for PLC which is normally used in Europe) data is injected onto and carried by the MV power line. The BPL signal is then transferred to the LV power line via couplers or through the LV transformer and delivered directly to the end-user. In the case of LV only BPL systems, the BPL signal is injected onto the LV power line at the transformer or the utility meter (SMSE, 2005).

1.3. Digital communications

Figure.1.3. illustrates a digital communication system, which uses the power line as its communication channel. The output impedance, Z_t , of the transmitter,

and the receiver's input impedance, Z_I , are the most significant elements of the Power line channel system.

The communication system is connected to the power line through a coupling circuit. There is a twofold purpose of the coupling circuits;

- 1) To provide the specific signal transmission with the appropriate bandwidth, i.e. it makes sure that most of the part of the transmitted signal remains within the frequency band which is used for the communication.
- 2) The safety level required by the applicable domestic or international standard, i.e. It is responsible for the prevention of the 50 Hz, from entering the equipment.

This ensures that the receiver's dynamic range is increased and no interfering signals are introduced by the transmitter, on the channel (Wang, 2006).

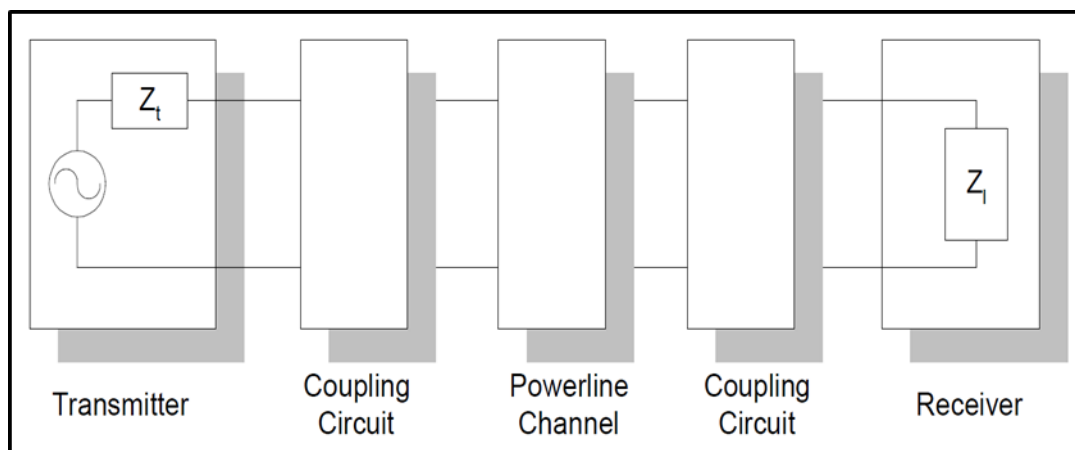

Figure.1.3. A digital communication system for the power line channel

The performance of a PLC system can be reduced because of the following:

- Impedance mismatching at the transmitter, $H_{in}(f,t)$.
- Attenuation of the Channel, $H_{channel}(f,t)$.
- Noise, $N(t)$.
- Impedance mismatching at the receiver, $H_{out}(f,t)$.
- Time-variations of the Impairments.

A power line channel model is shown in Figure.1.4. All elements in this model, apart from the noise, can be modelled as time variant linear filters (Proakis, 1995).

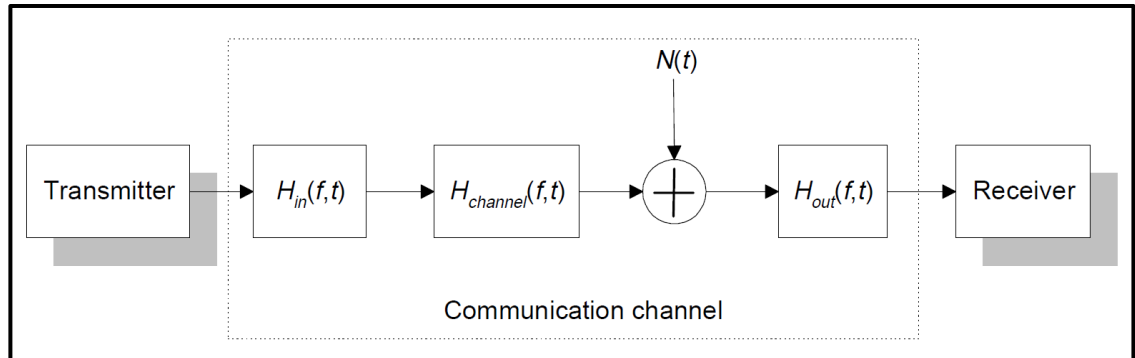

Figure.1.4. Impairments present on the power line (Proakis, 1995)

As it is shown in Figure.1.5. all the above mentioned impairments can be formed into a single time variant filter $H(f,t)$.

Although, this model is quite simple, it still covers the properties that are important to the design of the communication system and its related performance. The noise and the transfer function can be estimated by theoretical analysis or even through measurement (Proakis, 1995).

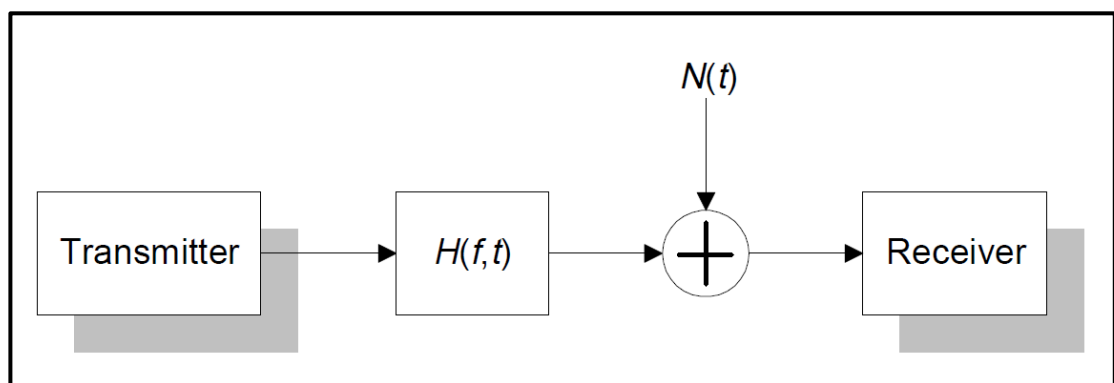

Figure.1.5. A simplified model of the power line channel

The *Comité Européen de Normalisation Électrotechnique* (CENELEC) is the European Committee for Electrotechnical Standardization that certifies the

bandwidth on regions in Europe. The allowed frequencies by the standard is only between 3 kHz to 148.5 kHz which might not support the high bit rate data transmission. The required bandwidth for data transmission with higher bit rate is between 1 to 30 MHz (Brown, 1998). An interference with any other communication system such as a radio and airplane navigation within the part of this frequency band requires more consideration. It means that these communication systems might disturb the communication on the power line or vice versa. (Yang, et al., 2009). PLC operating bands are shown in Figure 1.6.

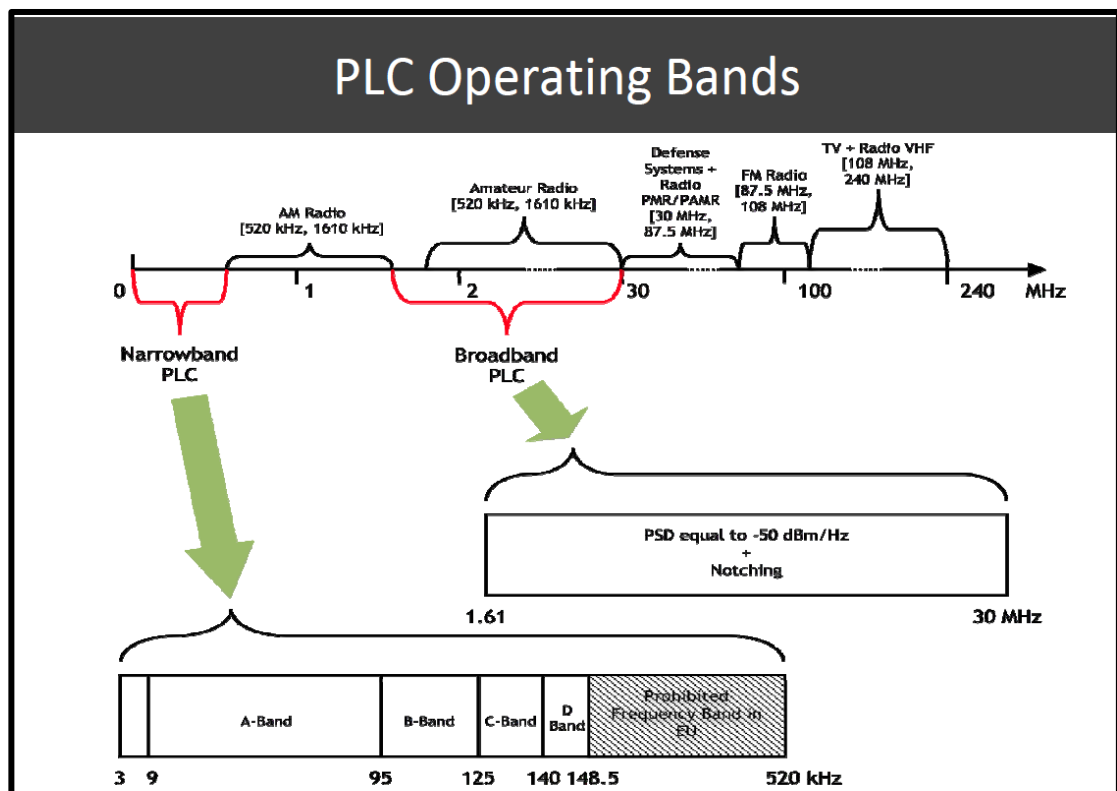

Figure.1.6. PLC operating bands in Europe (Yang, et al., 2009)

1.4. Thesis Objectives

Today, there is a huge interest in the PLC system to provide internet access to customers in their homes and offices. There is a great potential for PLC technology to provide high speed broadband over the most ubiquitous wired

network without the need for any additional new wiring which is a great save on cost. However, power line grid were originally only designed for the distribution and transmission of electrical signal at 50/60 Hz. Therefore, they are harsh environments for the purpose of data transmission. Hence, different types of noise, attenuation and multipath fading are some of the most undesirable characteristics of the power line channels. The multipath model for channel with various effected topologies such as variation in loads, branch and length is investigated. Middleton class A noise which is closest to the real impulsive noise has been chosen for this research study and modelled in Matlab. One of the available modulation approach for PLC is an OFDM technique which can minimise the effect of inter symbol interference caused by multipath propagation. The data might get lost during the data transmission when the power line is interfered by switching on/off the electrical devices. OFDM technique uses a number of subcarriers for small packets of data to deliver within the home. Thus, losing one subcarrier only implies losing a small portion of data rather than the whole data. Channel coding such as hamming code, TCM and rectangular QAM TCM has been modelled and applied to the PLC system to enhance the quality of the data transmission. Figure 1.7 illustrates the extent of the research work carried out in this thesis.

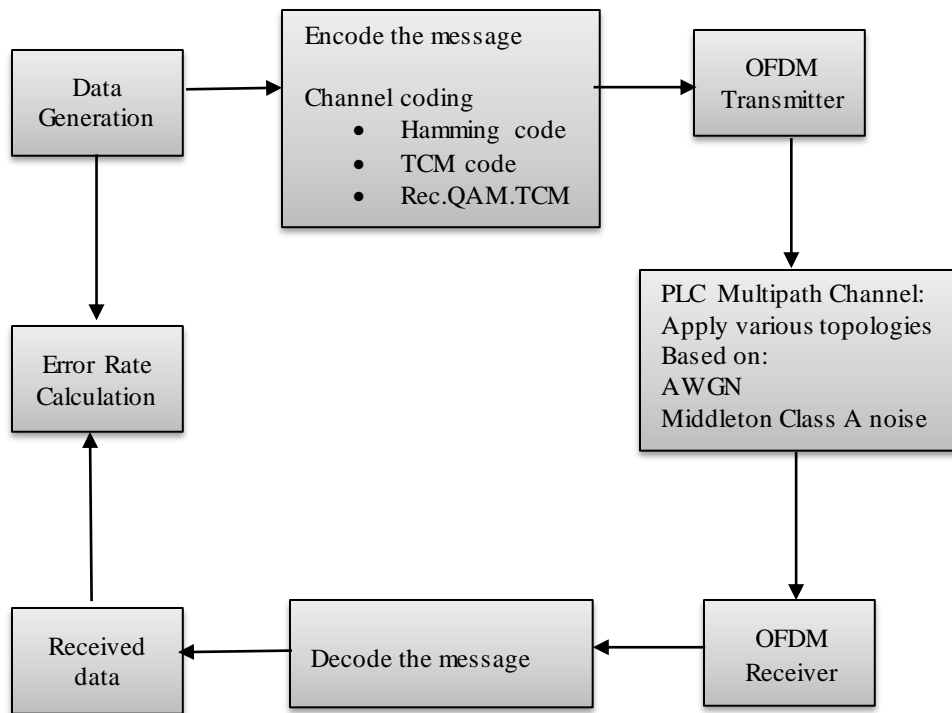

Figure.1.7. PLC model for this research study work

1.4.1. Research Questions

The research questions will be addressed on the following specific objectives to fulfil the overall objective:

- What is the best suitable channel model to describe the characteristics of the power line channel with the contain noises?
- How does the number of branches contribute to the total data transfer response?
- How does the line length from transmitter to the receiver and branched line length influence the frequency response?
- How do the terminal load (infinite and low) impedances influence the signal response?
- How can the effect of impulsive noise in PLC be reduced?

- How efficient are channel coding techniques such as hamming and TCM in reducing the effect of impulsive noise in PLC systems?
- How can we maximize the data rate in PLC system and achieve acceptance BER?

Currently, there is no complete systematic approach conducted to provide answers for the above questions due to the complexities and uncertainties involved in the adopted PLC modelling. In this thesis a number of case studies have been carried out for different channel topologies in order to provide guidelines for a possible future optimal planning and design of PLC systems.

1.4.2. Research Aim

The specific objectives arising from the above questions have been addressed.

These can be summarised as follows:

- (i) Investigate the use of the frequency response of PLC channels.
- (ii) Develop accurate PLC models for various power line topologies (different loads and various numbers of branches).
- (iii) Investigate efficiency of high data rate modulation techniques such as OFDM over various PLC.
- (iv) Develop a model to mitigate the effect of an impulsive noise on the PLC system.
- (v) Apply different channel coding schemes and find the best suitable coding approach to enhance the transmission over the power line channel.

1.4.3. The Research Methodology and Design

The research process plays a central role in science. To support research and researchers, it is necessary to understand the research process and its phases. Although the literature offers different research processes, these are often focused on specific research paradigms and methods.

This research study will ease the use of an existing power line channel for communication purposes such as getting an access to the internet from the power line grid. There are different methods for doing research;

- I. The deductive research where the findings are derived using a theory
- II. An inductive approach builds theories based on the findings

Considering the methods adopted in the previous researches (in the literature), designing a model for data transmission over the power line channel in this thesis requires both inductive and deductive approaches. The deductive approach in this research begins with gathering data from specified document, analysing existing power line channel models, deriving mathematical equations for the capacity of the power line grid and testing theories. Based on the results and outcomes from the deductive method, an inductive method is applied to design a new model for enhancing the data transmission over the power line channel.

The research begins with analysing the existing knowledge and the latest development about PLC systems and formulating the main research questions and design problems. A model system for a PLC channel with different scenarios such as varying the length from the transmitter to receiver, the number of branches and etc. is designed. Then PLC channel characteristics in presence of an impulsive noise and background noise, based on OFDM

modulation technique are investigated. A Middleton class A is modelled in Matlab as an impulsive noise, whereas an AWGN noise modelled as a background noise. In order to reduce the effect of noise and enhance the data transmission various channel coding techniques such as a hamming, TCM and Rectangular QAM TCM are also designed and applied into the PLC system. As an alternative to experimental design, the results are validated by critical comparison to existing case studies and literatures.

1.4.4. Original Contributions

This research study contributes a number of original works in the digital communication field with the main focus in PLC based on OFDM, under AWGN and Middleton class A noise. Various channel coding such as hamming, TCM and rectangular QAM TCM have been used to enhance the performance of the data transmission in the PLC. The main contributions in this research investigation are summarised below:

a) Main contribution of the PhD research work:

- The use and validation of applying different topologies such as varying the loads, number of branches and etc. with the use of the Multipath channel model for LV European power lines.
- Applying and analysing the effect of hamming code in OFDM based PLC system. The approach was studied under the multipath channel model in the presence of an impulsive noise (Middleton class A) and different conditions.
- Perform analysis of OFDM based PLC system under Middleton Class A noise and AWGN.

- Performance evaluation for TCM / rectangular 16-QAM TCM using OFDM modulation is explored with the Viterbi decoding and puncturing scheme to improve the BER of the PLC.

b) Development/external contribution:

- Modelling and Performance analysis for PLC with AWGN and impulsive noise. Middleton Class A is used as an impulsive noise.

1.5. Summary

In this section the current research focused on the characteristics of the power-line as a communication channel and the development of effective communication methods was discussed and analysed. The channel characteristics of a power line are important to design PLC systems. The development of PLC system requires detailed knowledge of the power line channel properties, interference scenarios and suitable transmission methods.

A quick introduction to the digital communication system and power line distribution was also presented.

1.6. Thesis Organization

This thesis comprises seven chapters. The first chapter serves as an introduction to the research study whereas the second chapter presents a quick literature survey of the PLC and related topics. The dissertation is organized as follow:

Chapter 2: Literature Review

A Literature survey on PLC systems is made in chapter two. Originally power lines were not designed for high speed data communication purposes, therefore the chapter begins by outlining the basic structures and physical properties of

power line networks and a quick background of communications over power lines. A review of the previous work/researches done in modelling PLC systems and related fields, and the existing impulsive noise in the PLC is given in this chapter. The use of OFDM modulation in PLC applications is also explained. Applying different channel coding to enhance the data transmission is also given. The chapter finishes by presenting some of the common security approaches for more reliable PLC technology as well as the feasibility of such a system.

Chapter 3: Data Transfer over Power Distribution Networks

PLC systems were not designed for the purpose of high-speed data transmission as they consist of various branches and power line elements such as bridges, taps, transformers and capacitor banks. Therefore, the power line transmission medium not only introduces noise, but is also adverse to high-speed data transfer in terms of the channel bandwidth. In this section a power line channel has been modelled using Matlab and the effects of variations in the direct length, branch length, different number of paths and branch load on the channel frequency response are investigated. Simulations indicate the suitability of multi-carrier transmission over the power line channels.

Chapter 4: Bit Error Rate Performance in Power Line Communication

Channels with Impulsive Noise

As a major impairment for PLC transmission, impulsive noise and various available modes are investigated in this section. Middleton class A is chosen as a best suitable model for an impulsive noise. The mathematical model is discussed in the first section of this chapter. The performance of PLC degrades due to the presence of different types of noise interferences generated by

electrical appliances. This section investigates the BER performance of a higher-order 16-QAM constellation with orthogonal frequency multiplexing modulation (OFDM) in presence of impulsive noise modeled as Middleton Class A over a multipath PLC. It is observed that BER for the impulsive noise is higher than the background noise. The BER further deteriorates on increasing the level of the impulsive noise, even while being injected into the PLC channel at a lower rate. Investigations would assist applying methods to mitigate and reduce the effect of impulsive noise over PLC systems for higher constellations with a view to increase the data rates.

Chapter 5: Trellis Coded Modulation on PLC based OFDM

This chapter gives an overview of the TCM technique that is typically decoded by use of Trellis and Viterbi based decoding technique. Convolutional codes, especially TCM/rectangular QAM TCM based on an OFDM system in PLC are modelled in Matlab/Simulink and discussed. The reconstructed rectangular QAM TCM provides better BER performance compare to the general TCM for PLC multipath channel in presence of a Middleton Class A noise and AWGN.

Chapter 6: Validation, discussions and critical analysis

The obtained results in the previous chapters are presented and critically discussed in here. The chapter incorporates a balanced presentation of this research work compared to the existing readings. It carefully evaluates literature and provides an academic argument for the validity of other studies versus the one presented in this thesis.

Chapter 7: Conclusions and Future Work

This chapter summarises the main conclusions of this dissertation and presents possible future direction. This research study work is about power Line

communication channels which has interested several researchers and utilities during the last decade, trying to achieve more reliable communication over the power lines with higher bit rates.

Chapter 2

Literature Review

2.1. Introduction

Today Internet technology has become an important factor in business, academia, and daily life. Wired internet network (such as XDSL and cable networks) and wireless internet networks (such as a wireless local area network) are readily available urban areas rather than rural areas for commercial reasons. A PLC system therefore becomes an attractive option for high speed data transfer for communication. Broadband over power line can provide internet access over the power line system. A laptop or any other devices can be plugged into any power outlet (by use of PLC modem) in building to get access to high-speed internet (Cacciaguerra, 2003). The main advantage is to use the existing infrastructure of power line grid resulting in economising the infrastructure cost and providing internet to customers in rural areas who do not have access to cable modems. However, power line cables are not designed for transfer of data; therefore there are limiting factors such as electromagnetic interference, degrading the system such as from noise loads and other devices connected to the power line grid. Although, several approaches have previously been attempted to avoid these issues, such gaps still exist in providing high bit-rate transmission through power lines. The aim of the research is to develop and evaluate suitable technique and PLC properties for the design of PLC systems to reduce the effect of noise and also to maximise the data transmission over power line. In this chapter a survey of the

quick literature on PLC is provided. Undoubtedly in design any PLC model, adequate knowledge of the structure and properties of the power line channel is required (Anatory, et al., 2008). The chapter starts with outlining the history behind the development of PLC and the current advance in this technology followed by available modulation techniques and channel modelling for PLC technology. Over all this chapter serves an extensive knowledge of PLC that will be used in later chapters of the thesis to investigate the available approaches and develop new techniques to enhance and improve the performance of PLC applications.

2.2. Power Line Communications

2.2.1. History development of PLC

The idea of communication over a power line network dates back to the 1920s. It was introduced by the energy providers, to establish communication between their plants, Figure 2.1 The basic idea was to use the existing networks for communication such as narrow band tele-remote relay applications, public lighting and home automation rather than to establish a new one. Mid 1980s saw beginning of research on use of electrical power lines to support data transmission between the 5 – 500 KHz bands. In 1997 the first bidirectional data transmission over the power line network was tested and companies like Ascom (Switzerland) and Norweb (UK) began their researches on this field. Subsequently first tests were carried out by France and North America. It was observed that PLC systems have some limitations on data transmission (Cacciaguerra, 2003).

The main reason for development of communication over PLC channel was the need for a communication link to maintain the function of HV transmission systems. Companies for tasks such as monitoring, operations management, and fault finding required to create a new fast bidirectional flow of information between power plants, switching gears, transformer stations and coupling points. Due to the unavailability of telephone lines in all required communication points and also unreliability of the telephone lines (often caused serious interruptions during necessary communications) it was necessary to use the HV lines to fulfil the communication tasks. (G.Lazaropoulos, 2012) & (Schartz, Jan.2009).

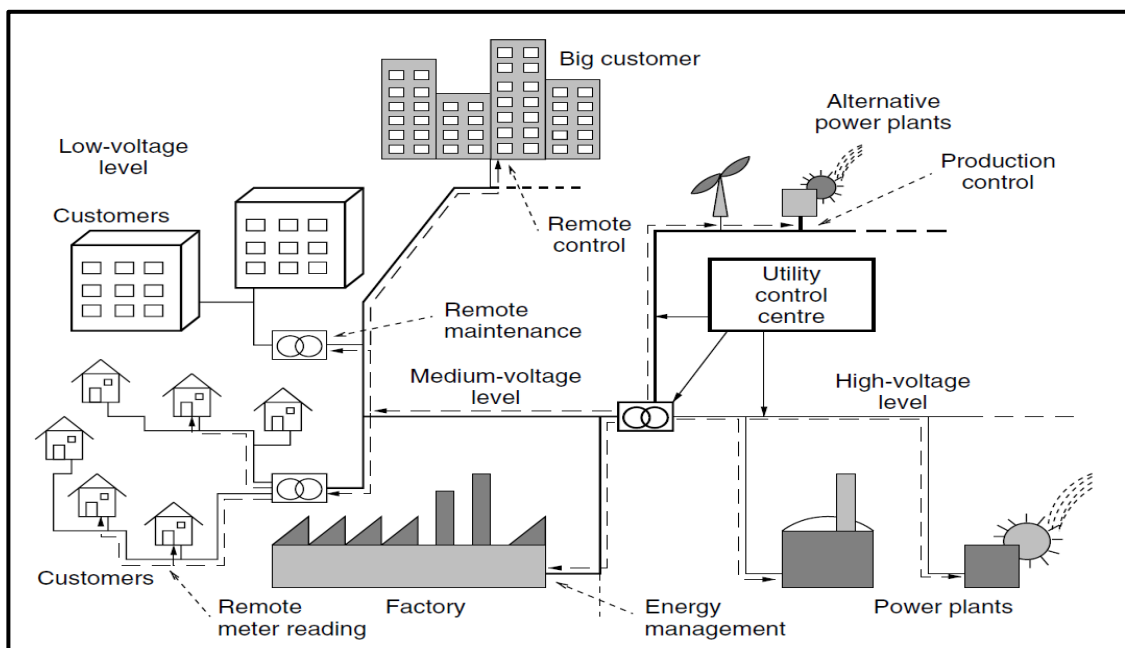

Figure.2.1.General structure of a PLC system for energy related services

Channel models are useful for design and modelling of communication systems. There are several power line channels available for PLC systems as the Philipps model, Zimmermann, Dostert model and the Anatory model. (Anatory, et al., 2008).

There are number of challenges facing transmission of data through power line system. Power line topology i.e. geometry and transmission voltage levels vary from region to region and country to country. For example in Tanzania the MV, LV and Indoor-Voltage (IV) systems have a potential to supply a broadband services through power line network to end users whereas in UK the potential of these has not been confirmed yet. The Comité International Spécial des Perturbations Radioélectriques (CISPR) (the special international committee on radio interference) after five years of study was unable to produce any conclusion which would guarantee reliable transmission of data through PLC.

(Zimmermann & Dostert, 2002) indicated that the maximum distance for a lossless data transmission through power grid is about 300 m. But later on it has been found that researches are still necessary to better understand and improve the performance of power lines for higher bit rate transmission (Pavlidou, et al., 2003). Some investigations have been done regarding the variation in time/frequency responses due to the influence of load impedance, branches and line length. But none of them mention the exact contribution of each parameter to the stochastic behaviour of channel responses.

One such example is the test and simulation done in Tanzania for a MV/LV line in which it is observed that as the line length increases there are rapid changes in the signal phase response. This could perhaps limit the available transmission bandwidth of the MV channel (Anatory & Theethayi, 2010).

Later on in (Hassina, et al., 2005) the influence of load impedance, branch line length, effect of number of branches and direct line length of transmitter to the receiver point on the performance of a LV power line network system is presented. In this work a deterministic model based on the transmission line

theory is presented for PLC systems. The main focus for this research was to signal degradations caused by the time variant connections of electrical devices on the power line grids. It has been established that the channel condition changes when customers switch on/off their electrical devices to power line socket. These observations can be helpful in suitable design for the BPL systems for reliable high-rate data transfer. (Hassina, et al., 2005)

(Anatory, et al., 2008) Conducted a laboratory experiments to validate PLC model by comparing the channel transfer functions. From these experiments, a good agreement between the PLC model based on transmission line (TL) theory and experiments are found for channel frequencies up to 100 MHz. Based on the model developed by (Anatory, et al., 2008) which was validated by using time-domain simulations using the alternative transient program - electromagnetic transient program (ATP-EMTP). A standard model was developed for a communication system with TL interconnections and distributed TLs along the line connecting the transmitting and receiving end. As simulations from their model indicate that the model can be used satisfactorily for determining of the transfer function of a power line grid with interconnections and branches.

According to (Olsen, 2008) an attenuation, delay spread due to multipath propagation, input impedance, different types of noise, interference from narrow band signals and modulation of the input impedance by the power lines are some of the challenges facing the designers of PLC systems. These challenges require the best suited modulation technique that can withstand these challenges.

An investigation done in many research studies such as in (Amirshahi & Kavehrad, 2007) for performance of OFDM modulation for high data rate transmission over PLC channels indicates that for better performance in data transmission of PLC systems, the OFDM is a well suited modulation technique for power line networks. In this modulation data are transmitted on a number of sub-carriers within the usable spectrum thereby increasing the data rate of transmission in a multi-path environment. Another advantage of OFDM is that frequencies/sub-carriers susceptible to interference can be turned off to avoid any interference. The obtained results from simulations show the single carrier schemes require complex non-linear equalizers to mitigate the effects of multipathing. It also shows that adding a linear equalizer to the system results in increasing the noise level rather than eliminating an intersymbol interference (ISI). As in other communication systems, coding increases the overall performance in terms of Bit Error Rate (BER). Block codes, and convolution codes such as hamming code and turbo coding repeatedly can be incorporated to improve the PLC performance.

In many papers such as (Andreadou & Pavlidou, 2010) and (Meng, et al., 2005) theoretical and practical model for noise in PLC are proposed and investigated. The noise in PLC system is divided in five categories which are then grouped into two main classes: background and the impulsive. The effect of each class in PLC system in term of BER was obtained.

In (Maneerung, et al., 2011) the characteristic of PLC multipath channel in presence of noise model with OFDM for smart grid system was investigated. The simulation results showed that use of OFDM can improve the performance of such a system with better data transmission.

High peak to average power ratio (PAPR) in OFDM system for PLC is investigated in (Adebisi, et al., 2007). For PLC system with a high ISI introduced by power line channel, a suitable channel coding and equalisation scheme is required. The authors investigated the effect of turbo coding in PLC application. The simulation results show that, after performing a number of iterations, the performance of a Turbo Code orthogonal frequency multiplexing division (TCOFDM) system can possibly enhance the transmission over PLC system.

In (Anon., 2010) the performance of double binary turbo coded OFDM system in term of error probability in presence of Bernoulli-Gaussian noise in PLC system is analysed and simulated. The results showed that the double binary turbo coding technique offers considerable coding gain as well as encoding complexity and the system performance can be substantially improved by increasing the number of iterations.

In (Singh & Singh, 2012) convolutional coding technique with OFDM is used to overcome the multipath fading. Although such a system can combat the effect of multipath fading but it also increases the complexity of the system. In this work turbo coding technique error correcting approach is used. The BER performance of the TCOFDM under Binary Phase Shift Keying (BPSK) and Quadratic Phase Shift Keying (QPSK) and under Additive White Gaussian Noise (AWGN) channel is investigated. Simulation results demonstrated that the TCOFDM system with 4 iterations is sufficient to provide a good BER performance for PLC systems. Additional number of iterations do not have noticeable difference. It is also shown that the TCOFDM system achieves large coding gain with lower BER performance with a reduction in iterations number, thereby leading to higher data rate.

According to (Nakano, et al., 2003) power line channel suffers from impulsive noise interferences generated by electronic appliances which results in degradation of such a system. Middleton Class A noise as an impulsive noise model was chosen and its effects on a PLC system based on OFDM and Viterbi decoding is investigated. The computer simulation results showed that Viterbi decoding enhances the performance of the PLC system in the presence of Middleton Class A noise.

In (Bert, et al., 2011) the existing noise model, background and impulsive noise in PLC system has been reviewed. The effect the Middleton class A noise model for an impulsive noise in PLC system has been investigated. The obtained simulation results illustrated that the Middleton class A noise has a certain coloured spectrum related to the average path loss of the propagation channel which can have an effect on decoding process.

Many researches, based on Turbo Trellis Coded Modulation (TTCM) and applying OFDM into communication system have been studied. In (Wang & Wei, 2006) the effect of the impulsive noise on performance of the TTCM based on OFDM system has been investigated. The BER performance of TTCM based on OFDM for both AWGN and Ultra Wideband (UWB) channel in presence of an impulsive noise has been evaluated by simulations. Although the constructed punctured parity turbo trellis code with lower complexity using 64-QAM constellation proved to offer higher spectral efficiency in such a system, there are still several requirements to be considered to achieve higher data rate transmission for a communication channels in the presence of an impulsive noise.

Therefore, there is no completed research done for the investigation of a suitable data transmission over the PLC system. In this thesis hamming, TCM and rectangular QAM TCM coding systems based on OFDM under Middleton class A and AWGN for PLC are designed in MATLAB/Simulink and investigated.

2.2.2. Advantages of using power line communication system

PLC can provide extra services compare to XDSL and cable modem which would be a key element for a business model for internet service providers. Some of these potential list of customer services are listed below (Wook Kwon, 2009), for which an LV PLC network is used, Figure.2.2.

- Billing data and energy consumption data.
- Real-time building security monitoring/reporting.
- Automated inventory tracking of various goods such as fuel stocks.
- Dynamic price information.
- Video on demand.
- Streaming audio.
- Voice over Internet telephony.
- Automated monitoring and control of end-use equipment, including demand response and load shedding.
- Real-time, interconnected Internet-based games.
- Transmission of data/telephone/fax without multiple fixed lines.
- Triple play services; voice/data/video (Wook Kwon, 2009).

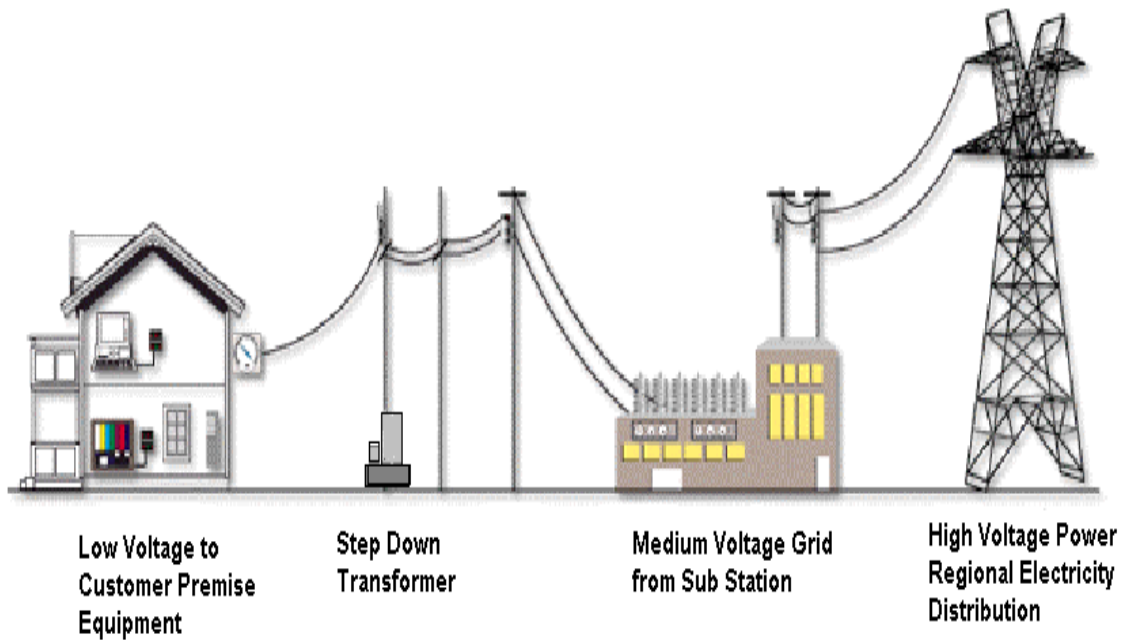

Figure.2.2. Power Line Communication network

2.2.3. Power Supply network

Three different network levels are present in an electrical power system which can be utilized as a transmission media. The three levels are (Hrasnica, et al., 2004):

- **High Voltage:** HV refers to voltages in between 110 and 380kV. HV networks are used where long distance connection is required like connecting continents, states, cities, countries, etc. for exchange of power. HV networks are utilized for connecting power stations with customers that require high power and voltage and also for supplying power to large supply regions. Overhead cables are used for implementing HV networks.
- **Medium Voltage:** MV refers to voltages in between 10 and 30kV. MV networks are used to supply power to customers' at large distances but these distances are considerably smaller in comparison to the distance in which HV networks run. They are used to supply power to industries,

large cities or commercial customers that operate at MV. Both overhead and underground cables can be used for implementing MV network.

- Low voltage: LV refers to 230/400 V in the UK and 110 V in the USA. LV networks are utilized for supplying power to customers within a few hundred meters. LV networks are used by small customers that are usually residential customers. Underground cables are used for implementing LV networks in urban areas whereas over-head cables are used in rural areas. LV networks are present both inside the house and outdoors. The outdoor LV network includes the connection from the house to transformers and is the property of electrical supply utilities. The indoor connections are connected to the outdoor network via a meter unit (M).

In LV networks huge numbers of customers are connected and therefore the implementation of the PLC in such networks is quite useful as this technology will help to efficiently manage the provision of broadband to customers. The so called “last mile” in telecommunications can also be easily implemented using the PLC technology because the “last mile” is the connection between the customers and transformer unit which is usually covered by low voltage networks as it is shown in Figure.2.3. (Hrasnica, et al., 2004)

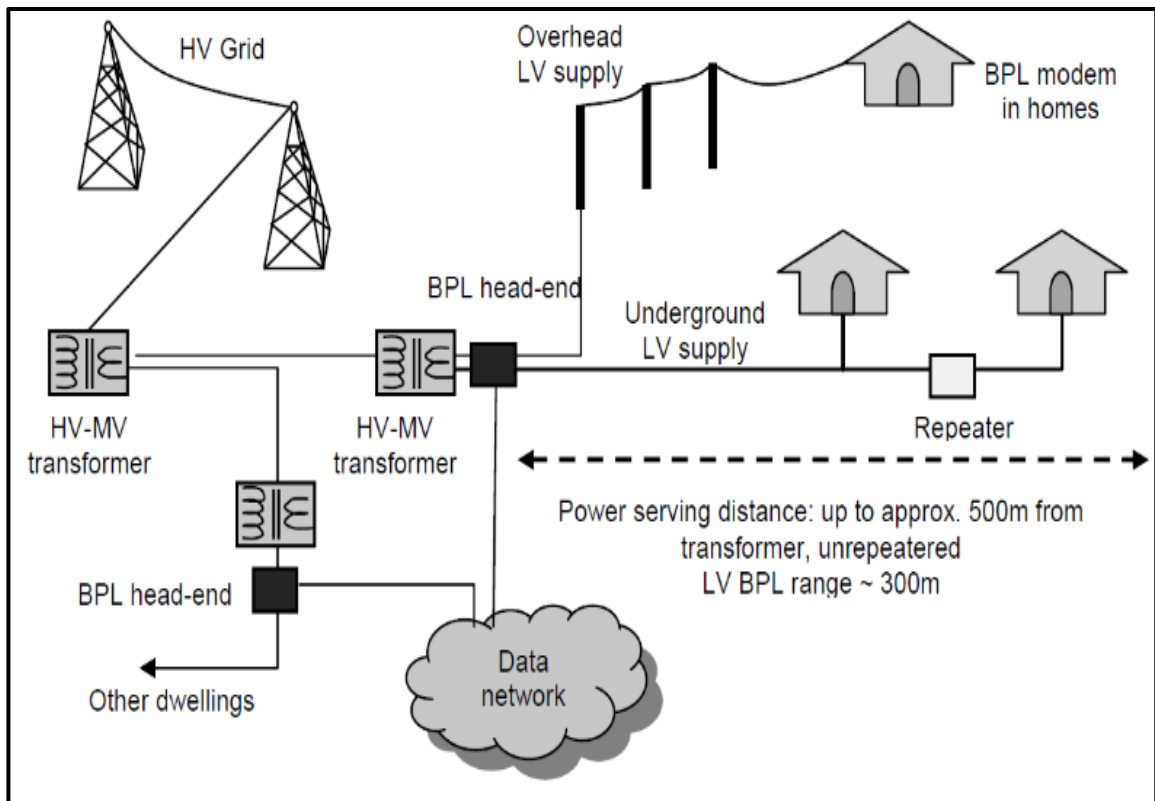

Figure.2.3. LV PLC access network (Wook Kwon, 2009)

2.2.4. Power line communication Standards

A number of standards have been developed for electrical power line channels. The various standards include the European standard, American and Japanese standards. The American and Japanese standards provide a frequency range up to 500 kHz. The European standard- CENELEC EN 50065 provides a frequency range from 9 to 140 kHz.

The European standard- CENELEC EN 50065 allows data rates up to several thousand bits per second only, which can be utilized in data transmission that use very low bit rate such as implementation of voice channels and some metering functions like remote meter reading, load management in electrical networks, etc (Hrasnica, et al., 2004).

The PLC systems need to function in higher frequency ranges (up to 30 MHz)

for allowing data rates for the communication to be possible. But no standards have yet been specified which allows the PLC systems to operate in frequency bands greater than that specified by the standards like the CENELEC. A number of bodies are working on standardization of broadband PLC networks, some of which include:

- The PLC forum is one of the international organization that works on providing a platform for research in PLC. This organization has approximately 50 members including electrical supply utilities, research organizations, manufacturer companies, network providers and many others. For smooth and efficient working of the organization, this organization have been divided into four groups namely regulatory, in house, technology and marketing groups.
- The Home Plug Power line Alliance. This organization is closely related to the PLC forum and is a non-profit organization working on in- home PLC solutions. Its aim is to provide platform for people to work on developing high speed home power line networking products and services.
- European Telecommunications Standards Institute (ETSI) and CENELEC as in table I also work on standardizing the broadband PLC technology (Hrasnica, et al., 2004).

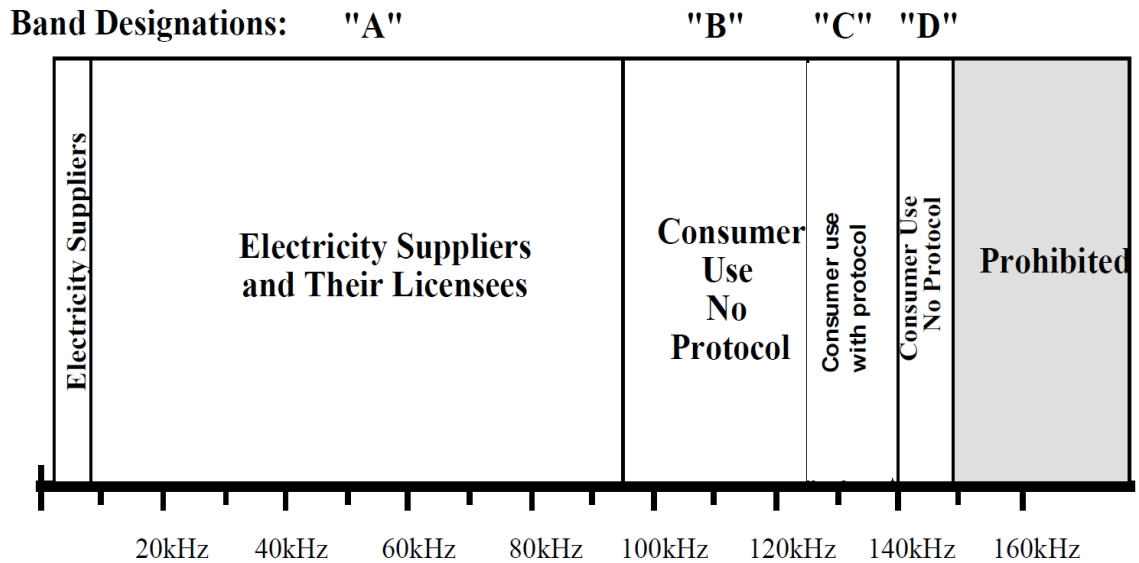

Table.2.1. CENELEC bands for narrowband PLC network (Sutterlin & Downey, 2005)

2.2.5. Impact of interference and data rate limitation

Due to the increased sensitivity, PLC cannot be implemented over long distances. The interferences to the PLC system come from both the components of the PLC system and from other services like short wave radio, etc. in which the operating frequency is below 30 MHz. Interferences from within the system include the use of heavy machineries like TV and computer monitors, electromotor, and frequent switching of appliances and phase angle control devices also result in disruption in the network. Other than the interferences caused by components within the PLC system and other services, interference can also result from the adjacent PLC systems. Different techniques must be employed for resolving this problem to ensure an effective and reliable PLC system. Chapter 4 discusses in detail the various noise and disturbance in PLC systems and the different interference model that have been designed for illustrating the noise in PLC systems. Several error handling techniques have been developed for handling the interferences to allow error

free transmission. One such a technique is the use of forward error correction in which the original data can be recovered even in the presence of noise. Another technique that can be used is the Automatic Repeat Request (ARQ) mechanism in which extra transmission capacity is again utilized for retransmission of the defective data and this retransmission of data also introduces transmission delays (Hrasnica, et al., 2004).

The data rate of the PLC systems is low and they are further slowed down by the use of error handling mechanisms. These error handling mechanisms are a necessity in PLC systems to ensure effective and consistent error free transmission. Another reason for decreased data rate is that the PLC networks link a number of subscribers using low voltage networks for transmission. A PLC network thus can be considered as a network having a shared medium for transmission but all the customers are dealt independently. This is one of the major reasons for reduced PLC system capacity (Hrasnica, et al., 2004)

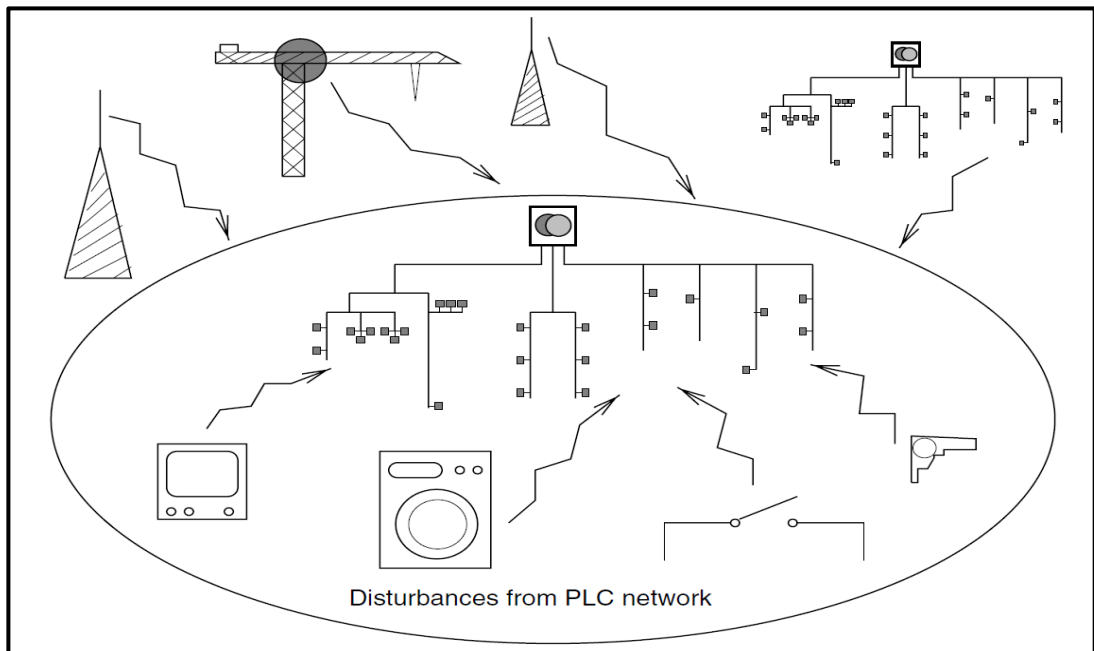

Figure.2.4. The influence of various interference sources.

2.2.6. Realization of broadband PLC transmission systems

The data transfer is accompanied with interferences and noise which include colored noise, echoes, impulsive, along with the additional effect of narrow band interferences. Therefore the modulation technique that is to be utilize enough to handle all sorts of disturbances is required. The suitable modulation techniques for PLC system include OFDM techniques and Direct Sequence Spread Spectrum (DSS) (Del Re, et al., 2001) & (Tachikawa , et al., 2002).

DSS provides a number of advantages including the possibility of implementation of Code Division Multiple Access (CDMA), reduction in Electromagnetic Compatibility (EMC) problems, possibility of functioning at low power spectrum and shield from narrowband interferences (Schulz & Schwarze, 2007).

Along with numerous advantages, the DSS technique also has some disadvantages; the sensitivity to frequency selective fading, low spectral efficiency and low pass characteristic are some of these drawbacks. Due to these drawbacks, PLC networks require complex signal equalization (Dotert, 2001). OFDM technique provides higher bandwidth because of the spectral overlapping and orthogonality of the subcarrier. OFDM also provides increased resistance for signal distortions and reduces channel equalizer complexity. The frequency ranges that get influenced by narrow band interferences can also be easily avoided using the OFDM technique. Due to these advantages, OFDM is an optimum option for implementing in PLC networks (Ma, et al., 2005).

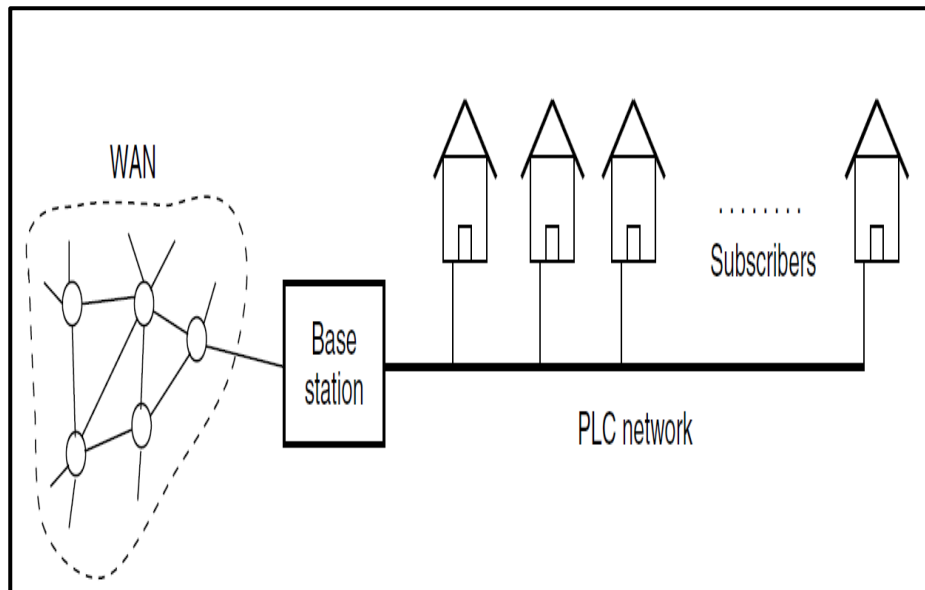

Figure.2.5. Shared transmission medium in PLC access network

The power line impedance varies with the frequency reliant on the appliance and the location and the value can fluctuate from a few ohms to few kilo-ohms. The discontinuities in the impedance result in multiple reflections in the cables due to which the power line can be considered as a multipath channel. The impedance of the cables is affected by a number of factors; some of them are the topology of the part of the network under consideration, the nature of electrical loads connected, and the characteristic impedance of the cables. The results of some of the measurements conclude that for the entire spectrum the average value of impedance varies in between 100 and 150 Ω . In the case when frequency is below 2 MHz the average value of impedance is much lower and lies in between 30 and 100 Ω . Due to these varying impedances, there are transmission losses in the PLC networks.

The channel model of the power line can be explained using various approaches. The approach which has been discussed in the thesis has been designed taking into consideration the PLC as a multipath channel because of

the multipath nature for the power line. The multipath nature is because of the existence of impedance mismatch and branches that results in reflections.

The medium which is used for data transmission selects the modulation technique that is to be used in a communication system. As it has been discussed earlier, power line provides a number of parameters for data transmission like noise, channel selectivity, multipath, etc. Therefore, the modulation technique applied in the PLC systems must be able to handle all these issues along with being reasonable in cost.

The modulation being used must be able to overcome the non-linear characteristics of the channel. The non-linearity in the channel must be handled because it will result in increased complexity and cost of demodulator. Therefore, the modulation technique must be capable enough of dealing this issue without utilizing complex equalization. Another problem that the modulation technique can deal with is the impedance mismatch; this results in echo which ultimately causes delay in data transmission. The modulation technique being used must be flexible enough to pick or eliminate any desired frequency because there are certain frequencies that are greatly affected by noise and interferences or some frequencies may be assigned for various other purposes, thus, making the frequencies unavailable for the PLC communication (Hrasnica, et al., 2004).

2.3. Characteristics of power lines

The main purpose of PLC system is to use the existing electrical power line system to transmit high speed data. The earlier power lines were only a medium for electric transmission and distributions at 50/60 Hz. Later on the power line was used for low speed communication such as in for operation

management that provide the needs of electrical power supply utilities and also a remote metering. Until recently, with a fast development of technology the demand for high speed broadband over power line channel has increased (Carcelle, 2006).

The power line system distributes electrical power to various electrical devices connected to the power grid. Each of these electrical devices is characterized with capacitance (C), an inductance (L) and also depends on the current (I) that runs through the circuits. The inductance is actually the value of magnetic flux that is caused by the current that runs through the electrical circuit.

If an electric current (I) produces a magnetic flux (Φ), the inductance (L) of the circuit can be defined by (Carcelle, 2006):

$$L = \frac{\Phi}{I} \quad (2.1)$$

In the case of an alternating current (AC) with the Voltage (V) at a frequency (f), the above expression can be rewrite as:

$$L = \frac{V}{j2\pi f I} \quad (2.2)$$

The capacitance of the electrical circuit can also be defined in terms of the voltage (V) between the two surfaces and an electric charge (Q);

$$C = \frac{Q}{V} \quad (2.3)$$

The capacitance (C) for the AC voltage in the power line system can be defined as below:

$$C = \frac{I}{j2\pi f V} \quad (2.4)$$

An impedance is the overall opposition to the flow of the current in (AC) circuits. The impedance (Z) of a cable is made of capacitive, resistive and inductive components and can be define as (Carcelle, 2006):

$$Z = R + jL2\pi f + \frac{I}{jC2\pi f} \quad (2.5)$$

In case of a direct current running through the electrical circuit, the impedance of the circuit would be equivalent to a pure resistance. In power grid network, electrical devices are continuously turn on and off from the system. Therefore the input impedance for such a network is variable. This variation makes the modelling for the proper power line communication very difficult (Carcelle, 2006).

2.3.1. Power line channel model

For the development of any communication system, an adequate knowledge of the characteristics of the transmission channels are required. Based on the Channel Transfer Function (CTF) and its capacity the transmission technique and other design parameters can be then chosen. The suitable model for such a system needs to be able to describe the transmission behaviour over the PLC system.

In addition there are some other facts that affect the transmission in PLC channels such as;

- a) different types of noise (such as an AWGN and Impulsive noise),
- b) an effect of branching due to the complicated power line distribution structures.
- c) signal propagation along power lines as they do not only take a single path from the transmitter to the receiver.

d) reflections from load points.

There are several power line channels available for PLC systems such as the Philipps model, Zimmermann, Dostert model and the Anatory model (Anatory, et al., 2008). The multipath model has been used for this research study.

2.3.2. The multipath model

The structure and topology of power line are not the same as any other available telecommunication systems. In power line, the link between a substation and the consumers at their places is not presented by a point-to-point connection as it is structured in the telecommunication systems. In other word the propagation of data signal in power line networks follow a multipath channel very similar to wireless signals in cellular transmission networks not the same as a telephone line in a single path communication system (Zimmermann & Dostert, 2002).

As it is shown in Figure.2.6. the power line from a transformer substation is a single distribution line with house connections and various lengths/loads of branches from distributor cable (Tx is the transmitted point and Rx is the receiving point). In the Power line an impedance mismatches and various branching cause numerous reflections that leads to a multipath propagation with frequency selectivity. In addition signal attenuation resulted by coupling losses (depends on the transmitter design) and line losses (depends on length of the cables) has to be carefully considered in design of modelling PLC channel (Khalife, 2011). Due to the fact that there are different electrical devices with constantly being switched on and off which cause changes in the transfer function, therefore the channel transfer function is time-varying and depends on the location of the receiver (Biglieri & Toino, 2003).

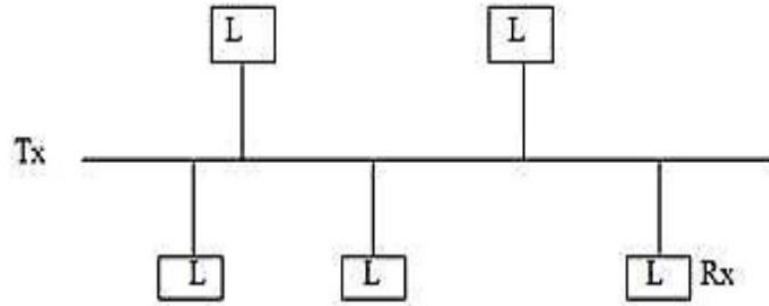

Figure.2.6. Typical topology of power line transmission line (Khalife, 2011)

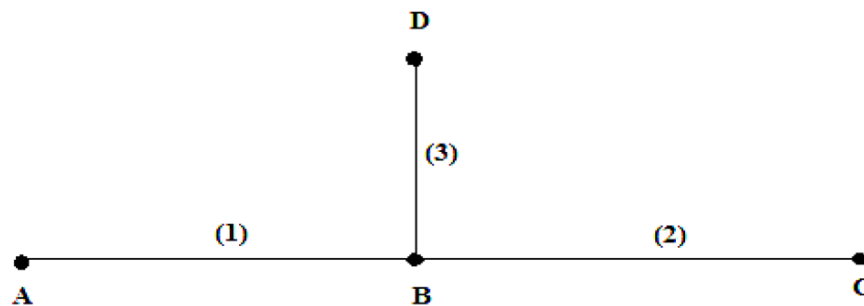

Figure.2.7. A multipath propagation data from A-C

In Figure.2.7. Let A be the transmission point and C be the receiving point. The signal generated at point A could take any of the possible following routs:

- A → B → A
- A → B → C
- A → B → D → B → A
- :
- :
- A → B → D → B → D → B → C

The bit error rate and the signal power of received signal at point C depends to the path selected and also the length of it. Multipath propagation is also responsible for delay (τ_i) in PLC system, which is given by:

$$\tau_i = \frac{d_i \sqrt{\epsilon_r}}{c_0} = \frac{d_i}{v_p} \quad (2.6)$$

Where C_0 is the speed of the light, d_i is the path length and $\sqrt{\epsilon_r}$ is the dielectric constant of insulating material.

The frequency response of the channel between two points is (f) . $A(f, d_i)$ are losses of the cable (in form of heat or signal leakage). (f) is the frequency of operation, g_i is weight factor which is directly proportional to number of reflections and the selected path:

$$H(f) = \sum_{i=1}^N g_i \cdot A(f, d_i) \cdot e^{-j2\pi f \tau_i} \quad (2.7)$$

$$|g_i| \leq 1 \quad (2.8)$$

Refer to the investigation in (Ma, et al., 2004) an experimental data $A(f, d_i)$ can be mathematically approximated by the formula for attenuation factor (α) ; Where a_0 and a_1 are attenuation parameters;

$$\alpha(f) = a_0 + a_1 \cdot f^k \quad (2.9)$$

therefore:

$$A(f, d) = e^{-\alpha(f) \cdot d} = e^{-(a_0 + a_1 \cdot f^k) \cdot d} \quad (2.10)$$

Based on all above given mathematic expression and Using $A(f, d_i)$ in $H(f)$ the mathematic multipath model, as it is shown in Figure.2.8., for PLC can be written as (Anatory & Theethayi, 2010) & (Hrasnica, et al., 2004):

$$H(f) = \sum_{i=1}^N g_i \cdot e^{-(a_0 + a_1 f^k) d_i} \cdot e^{-j2\pi f d_i / v_p} \quad (2.11)$$

Where:

g_i is the weighting factor,

$e^{-(a_0 + a_1 f^k) d_i}$ is an attenuation portion and

$e^{-j2\pi f d_i / v_p}$ is delay portion.

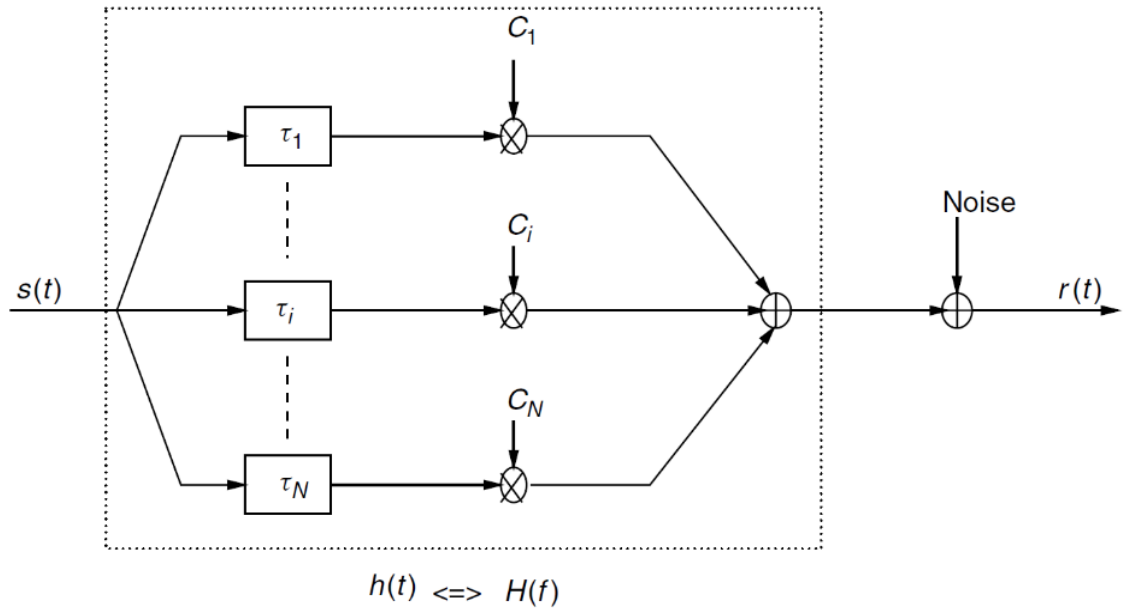

Figure.2.8. Multipath PLC channel model

2.4. Power line communication access network

2.4.1. Structure of PLC access networks

Access PLC uses power distribution line as a medium to deliver high speed broadband to the consumers in their homes. They are connected to the backbone communication networks (Wide-Area Network: WAN) via a Base Station (BS) usually just before transformers as it is shown in Figure.2.9. They use repeaters, injectors, and extractors to provide internet service to the customer. The communication signals from the backbone need to be converted into the form that makes the transmission over LV distribution line possible. This conversion normally being done in a BS of the PLC system.

The PLC subscribers are normally connected to the network via a PLC modem that is placed in either;

- the electrical power meter unit, the subscribers within a house or a building are connected to the PLC modem using another communications technology (e.g. DSL, WLAN).
- or connected to any socket in the internal electrical network, the internal electrical installation is used as a transmission medium that leads to the so-called *in-home PLC solution*.

The PLC modem deals with conversion of the received information from the network into a standard form which then can be processed by conventional communications systems. On the user side, standard communications interfaces (such as Ethernet) are usually offered. Within a house, the transmission can be realized via a separated communications network or via an internal electric installation (in-home PLC solution). In this way, a number of communications devices within a house can also be connected to a PLC access network (Hrasnica, et al., 2004).

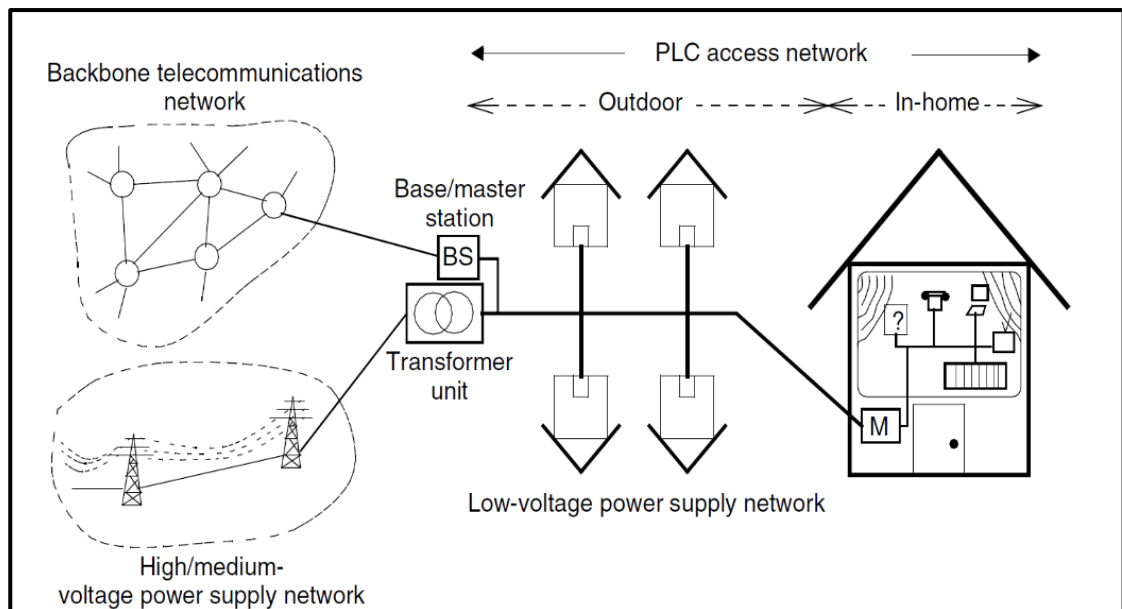

Figure.2.9. The typical PLC access network

2.4.2. In-home PLC networks

In-home PLC (indoor) systems use the electrical system as the transmission medium for the purpose of transmitting electrical signals. Telephones, computers, video devices, printers and other kinds of electrical devices can also be connected to the PLC systems installed within a house. This could save a lot of money because new communication cables would not have to be installed. Automation services are being increasingly used in the industrial and commercial sectors and large buildings. They are also being used in the houses of ordinary common people and automation services such as automatic light control, heating control and security observation are being employed. Electro-motors, sensors, cameras, lights and other types of electrical devices are interconnected to establish these automatic systems. The households and buildings which do not have an adequate communication system can possibly make use of the PLC technology to create automated networks.

The PLC access systems based on low voltage networks are quite the same as the PLC networks installed indoors. These systems have a base station which links the system to the area outdoors. The meter unit, or some other appropriate place in the indoor PLC system, can be the site for the location of the base station and PLC modems, like the PLC access network subscribers, are used to interconnect the different devices in the PLC network installed within the household as it is shown in Figure.2.10.

The power supply sockets in the wall are used to provide electrical power to the modems and the various communication devices can be linked to the PLC network installed in the house through the power outlets in the walls. The independent PLC networks are meant only for a single house or a building and

the PLC services within the structure cannot be used from far away, but the remote controlled PLC systems within the households can provide effective automation functions like security and energy management. A WAN communication system can be used to enable the users of an indoor PLC network to benefit from many telecommunication services from the electrical power outlets in the house. The PLC access systems can easily be linked to the PLC networks installed inside the house and other kinds of communication systems can also be accessed by the PLC networks. A power utility controlled access network can provide additional metering services by using the PLC networks. The remote electrical meter reading devices save cost and energy and a favourable tariff structure can be introduced (Hrasnica, et al., 2004).

The liberalization of the telecommunications market can benefit the indoor PLC network users and the broadband indoor systems can also be implemented by using other kinds of cost effective communications systems. Data transmission rates over 20 Mbps are provided by the Wireless Local Area Network (WLAN) networks. The WLAN also enables the users to use remote services, like cordless telephony, and it is easier to handle the communication devices used for such kinds of networks as they are portable.

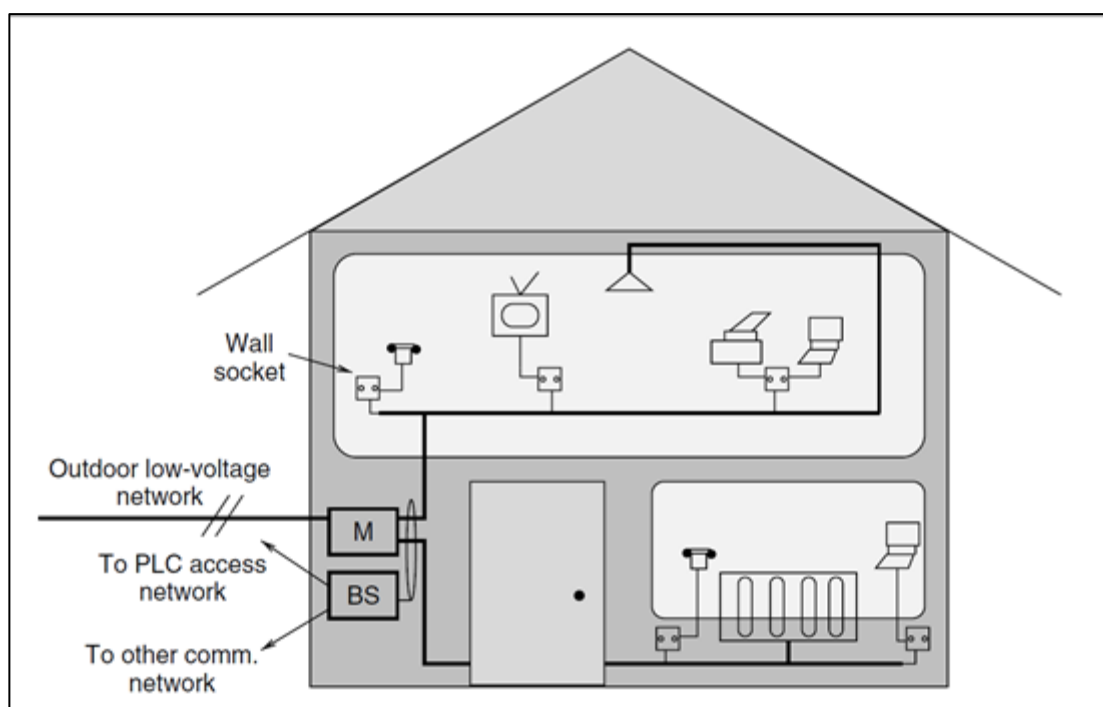

Figure.2.10. Structure of a PLC in-home network

2.4.3. PLC network elements

Data is transmitted by the PLC networks through the electricity supply system. Different kinds of communication and automation services can also be provided through the electrical power systems by converting the communication signals into a form which is appropriate for transmission through the power networks. This conversion is done by certain network elements in the PLC systems.

2.4.3.1. Basic network elements

Communication through the electrical power systems is possible because of the PLC network elements which convert the communication signals and transmit them over the power lines. These elements are also responsible for receiving signals. Any PLC access network will have the following two devices:

- PLC modem
- PLC base/master station.

The subscribers use standard communication devices which are connected to the electrical power lines through a PLC modem and standard interfaces can be provided by the user side interface. The Ethernet and Universal Serial Bus (USB) interfaces can be used for the transmission of information. A coupling technique is used to link the PLC modem with the power grid and the communications signals can be sent and received through the power lines. A safe galvanic separation must be provided by the coupling method so that only signals greater than 9 KHz are transmitted and the 50 or 60 Hz electrical power frequencies are filtered out (Hrasnica, et al., 2004) as it shown in Figure.2.11.

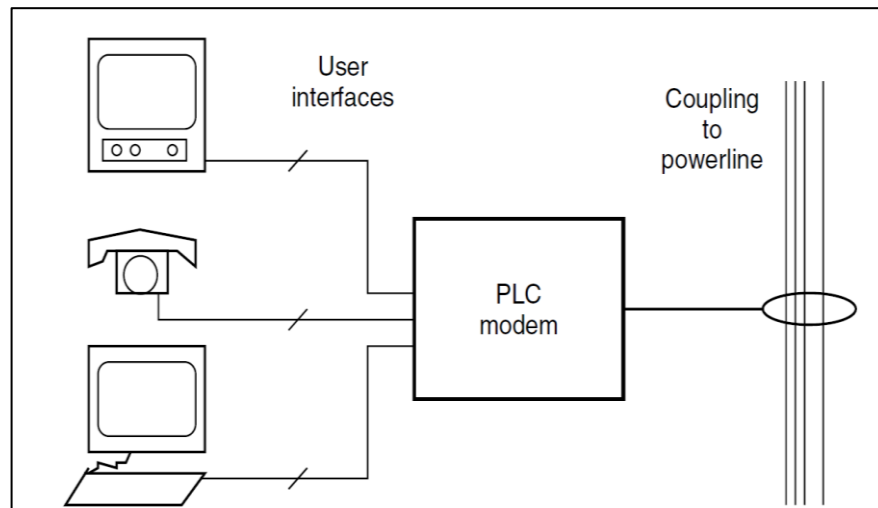

Figure.2.11.Functions of the PLC modem (Hrasnica, et al., 2004)

The coupling is done in the middle of the two phases in the access area and between the neutral conductor and a phase in the area within the house to reduce the electromagnetic emission as it is shown in Figure.2.12. (Dotert, 2001). Modulation, coding and other functions of the physical layer are carried out by the PLC modem. The data link layer exists inside the modem and the MAC (Medium Access Control) and LLC (Logical Link Control) sub-layers

(according to the OSI (Open Systems Interconnection) reference model are present inside it (Walke, 1999).

The link between the backbone network and the PLC access system is provided by the PLC base/master station, but the individual subscriber devices are not connected to the backbone system through the base station. Many interfaces for network communications, like Synchronous Digital Hierarch (SDH) and xDSL, are provided by the base station. These interfaces can be used to connect with a high speed network. Wireless Local Loop (WLL) can be used to connect with a wireless interconnection network. Different kinds of communication technologies can be connected to the backbone network by using the PLC base station.

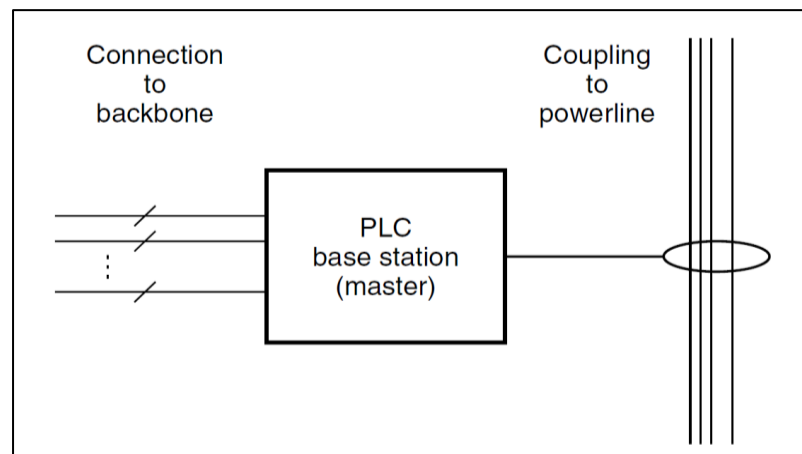

Figure.2.12. Function of typical PLC base station

The PLC access networks are controlled by the base station, but certain functions of the network can be controlled by other elements. The PLC modems can, sometimes, control the functioning of the network and connect it to the backbone network. In this way, certain functions of the network can be carried out or controlled by other elements of the network.

2.4.3.2. Repeater

If the distance between the base station and the individual subscribers, or the distances between the different PLC subscribers in a low voltage supply network, are too long, the PLC access system will not be able to function and a repeater could be used for the operation of long range networks. The PLC access network is separated into different network segments by the repeaters and these networks are divided into various time slots or bands of frequency. Transmission is possible inside the first segment by using a time slot and the second segment can be utilized by choosing a different time slot as it is shown in Figure.2.13.

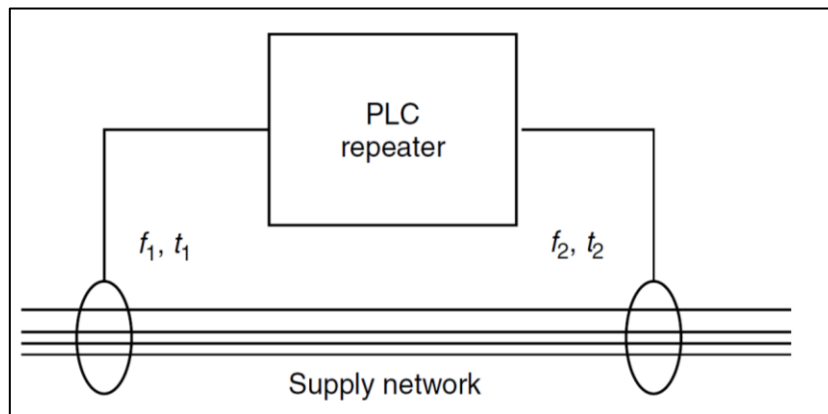

Figure.2.13. A function of PLC repeater

The network segment based on frequency has a repeater which receives the transmission signal having a frequency f_1 . This signal is amplified and fed into the network with a frequency f_2 . The transmission occurring in the other direction switches the frequency from f_2 to f_1 . The repeater can be used to modulate and demodulate the transmitted signal and it can also use a higher network layer to process the signal, but the information carried by the signal cannot be changed by the repeater and it passes unchanged through all the segments of the PLC access system's network (figure.2.14).

The transformer unit has a base station in and the first repeater is also located in the first network segment. The transmitted signal has a frequency f_1 . The signal has a frequency f_2 in the second segment. The two branches of the network are both used to send the signal in both directions and the transmission is not affected by the topology of the physical network.

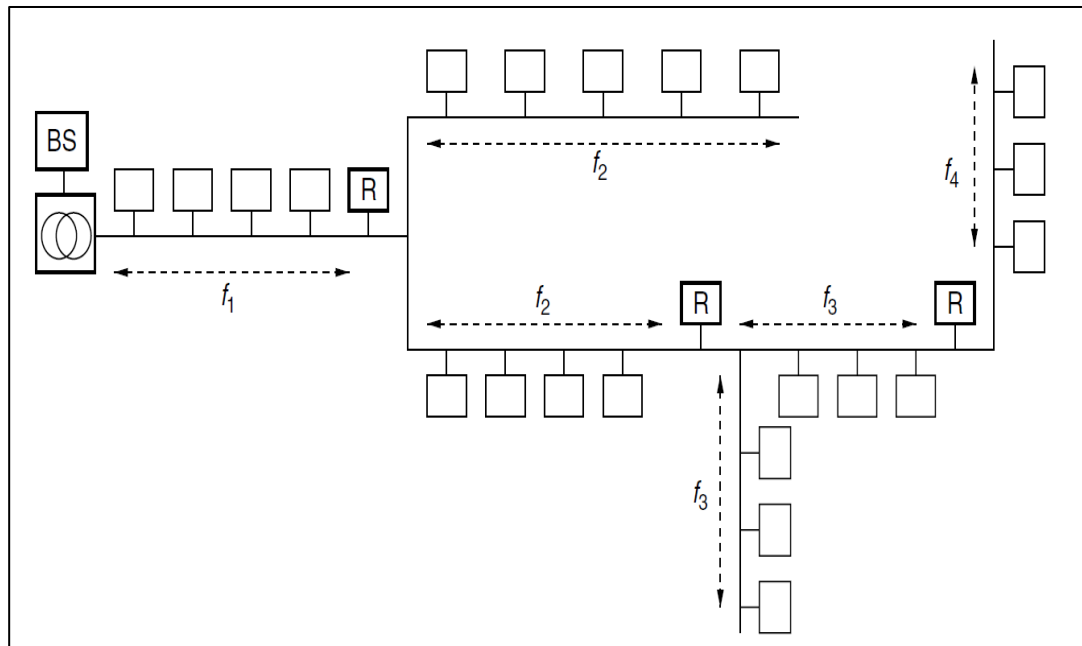

Figure.2.14. PLC network with repeater

The frequency f_1 could be utilized for the third segment of the network, in theory, but the signals from the first segment interfere with the signals from the third segment and this is the reason for selecting a frequency f_3 for the third segment of the network and a different frequency f_4 is used for the fourth segment. The PLC systems can only utilize frequencies up to the limit of 30MHz. This limit is set by the regulatory bodies for communication networks.

Various ranges of frequencies are used for the communication networks the capacity of these networks is decreased by separating the bandwidth into small segments and a limited number of frequencies can be utilized by the PLC

access networks. The network distances can be increased by using repeaters, but the cost of the network also increases due to the expenditures on purchasing equipment and installing it. This is the reason why a minimum number of repeaters must be used for the PLC access networks (Hrasnica, et al., 2004).

2.4.3.3. PLC gateway

The PLC subscribers can connect to the PLC access network through the wall sockets in two different ways:

- Direct connection
- Indirect connection over a gateway.

The first case consists of PLC modems which direct connections to the PLC base stations and the complete low voltage network (figure.2.15). The indoor and outdoor areas are not separated and the power meter unit serves as a medium for the transmission of the communication signal. There are certain problems related to the electromagnetic compatibility and the properties of the PLC transmission channel. These problems occur due to the difference in the indoor and outdoor power networks. The indoor PLC network can be separated by the PLC access network by using a gateway which converts the frequencies used for the transmission of the signals between the indoor areas and the access areas. The gateways are often placed next to the house meter unit as it is shown in Figure.2.16. The logical network division of the indoor and access areas can also be done by using a PLC gateway.

The data input into the access area is not needed for the internal communication between the PLC modems linked in an indoor network. The

PLC gateway acts as a local base station and it manages the communication between the internal devices, the PLC access network and the internal PLC modems (Hrasnica, et al., 2004).

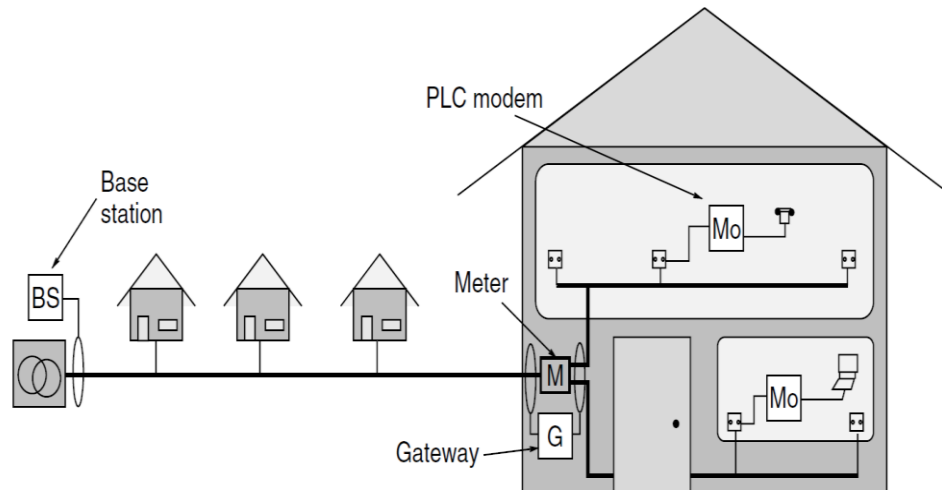

Figure.2.15. Subscriber connection over gateway

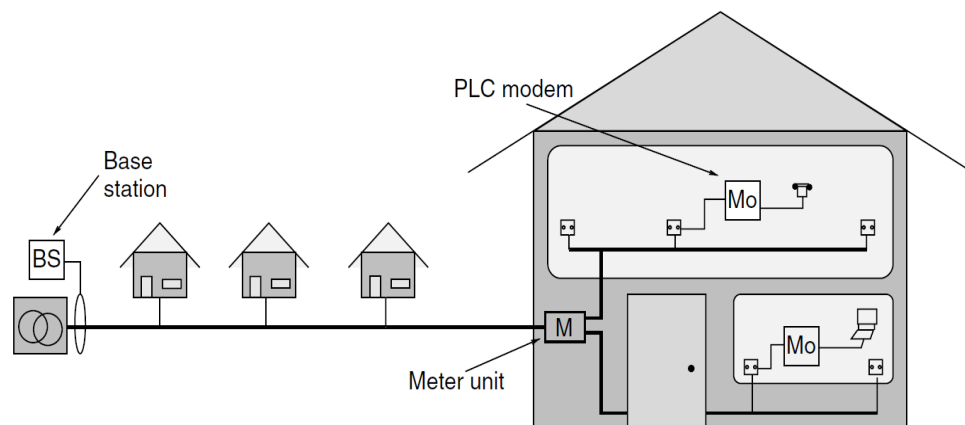

Figure.2.16. Direct connection of the PLC subscriber

The network division on the logical level and the signal regeneration (repeater function) can be achieved by a gateway which is located in a PLC access network. Many sub-networks are created by the division of the PLC system and they all use the low voltage network as a medium for transmission. They

operate independently of each other and the gateways (G) act as PLC repeaters and the signals within the frequency range of f_1 and f_2 , or time slots t_1 and t_2 , are converted by these repeaters. The frequencies between f_2 and f_3 (or t_2 and t_3) are also converted by these repeaters. The sub-networks II and III are operated by the gateways. The sub-network's internal communication is managed by the gateways and the remaining portion of the PLC access network functions normally. This is not very different to the operation of the indoor networks which employ gateways.

A specified gateway controls the communication between the base station and the sub-network, but the base station can also influence several subscribers (sub-network I) if the network is configured for this purpose.

The connection of the gateways to the network is not very different from the way in which the repeaters are connected as it is shown in Figure.2.17.

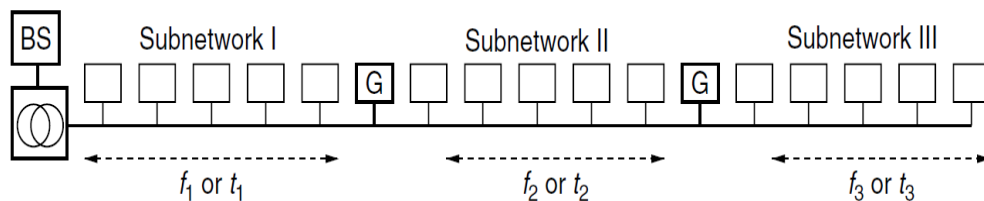

Figure 2.17. Gateway in the PLC access network

The capacity of the network decreases when the number of gateways is increased in the PLC access network. The cost of the network also increases. When a simple signal is forwarded by the repeaters from one network segment to another, the resources of the network can be effectively managed by the gateway and this makes the network perform better (Hrasnica, et al., 2004).

2.4.3.3. Connection to the core network

A PLC access network covers the so-called “last mile” of the telecommunications access area. This means that the last couple of hundred meters of the access networks are covered by the PLC access network when low voltage supply networks are used as the medium of transmission and these PLC access networks are joined with the backbone network by using the communications distribution networks. A local exchange is linked with the PLC base station through a distribution network. The network provider controls the local exchange. A new telecommunications network does not need to be established when the PLC technology is used and this saves money. Backbone networks are used to connect the PLC access network to the WAN and this increases the cost. The PLC backbone network must be implemented with minimum costs so that it is able to compete with the various access technologies used by the PLC networks (Hrasnica, et al., 2004).

2.5. Applications of power line communication

Due to the increasing importance of communication, the power line channel has been considered as a good candidate for the communication medium. PLC is using an existing power line system, i.e., this is a great saving in cost and time. The general idea of PLC system is to modulate a radio signal with data and transmit it through power line channels in a different band of frequencies that are not used for supplying electricity. PLC technology can be divided into two categories; the narrowband and Broadband communication. The frequency range of up to 150 kHz is for narrowband with the theoretical bit rate of kilobits (up to 2 Mbit/s). The frequency range for Broadband technology is between

1.61-30 MHz with theoretical bit rate up to 200 Mbit/s. Remote switching of public lights (single- directional communication), gas/electric meter reading and home automation application such as fire detection and intruder alarm (bidirectional application) are some of the narrowband application for PLC. Nowadays due to increase in demand for high speed data broadband, PLC technology provides a wide range of application such as video, voice, multimedia and networking to customers at their houses (Agrawal, et al., 2011). This section provides an overview of the narrowband and broadband technologies and some of their applications in PLC.

2.5.1. Narrow band over PLC (Smart metering)

The narrowband PLC are normally used in automation systems. The automation systems based on PLC technology are implemented with no any additional insulation of communication networks, which results substantially reduction in costs for the installation and realization of the new network within the existing buildings. The automation system in this system can be used in (Fernandes & Dave, 2011):

- i) Central control of various home system such as controlling doors/windows
- ii) Controlling connected devices to the internal wiring such as lighting, air conditions
- iii) The Security function, sensor control

Another application for narrowband technology is called smart metering. The smart meter system includes meters at the consumer site, communication medium between a service provider and consumer, such as a gas, an electric, or water, and data management systems in a service provider site

that make the information available. The smart meter transmits the collected data through PLC to a Meter Data Management System for data analysis and billing (Consumer Focus UK GOV, 2013).

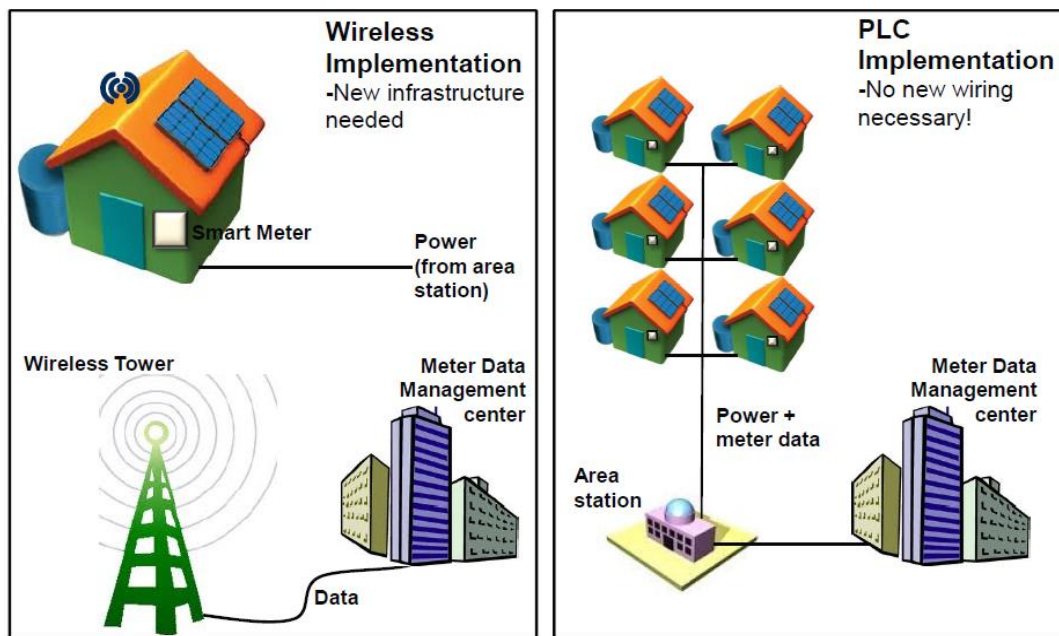

Figure.2.18. The Smart Metering System (Fernandes & Dave, 2011)

If you get a smart meter in your house/building you should get the following benefits:

- a) Accurate bills; the smart meter sends information to your energy provider on how much energy you have exactly used, so no more estimated bills.
- b) Could help to save money; by knowing what you're using, and having an idea of which appliances use the most energy, you may be able to reduce your energy usage and save money.
- c) A standard in-home energy display; has a small screen which shows your energy usage at any one time with no any additional cost.

- d) Reduced theft of energy; the energy theft detection is more easily, therefore it can be easily prevented, meaning you won't have to pay for stolen energy (Consumer Focus UK GOV, 2013).

2.5.2. Broadband over PLC

Today internet technology has become an important factor in business, academia, and daily life. Wired internet network and wireless internet networks are readily available urban areas rather than rural areas for commercial reasons.

A PLC network therefore becomes an attractive option for high bit-rate data transmission. A PLC system is emerging as an alternative to the broadband access network. Broadband power line can provide internet access over an ordinary power line. A laptop or any other device can be plugged into any power outlet (by use of PLC modem) in building to get access to high-speed internet. The main advantage is to use the existing infrastructure of power line networks resulting in economising the infrastructure cost and providing internet to customers in rural areas who do not have access to cable modems. About twenty four million homes in the UK will be required to have a smart meter for gas and electricity by 2020. It would be cost effective to install PLC at the same time (Fernandes & Dave, 2011).

Today's broadband over power line grids has three primary parts (Gellings & George, 2004) :

- 1) Internet access as the substation connected via backhaul, which can be fixed wireless, fiber optic or any other communication systems.
- 2) Use repeater/extractor on the MV line enable digitised data to be conveyed through the distribution power line.

- 3) Use devices such as Modem, couplers or extractor to move the data around or through the transformers to connect to the consumer premises.

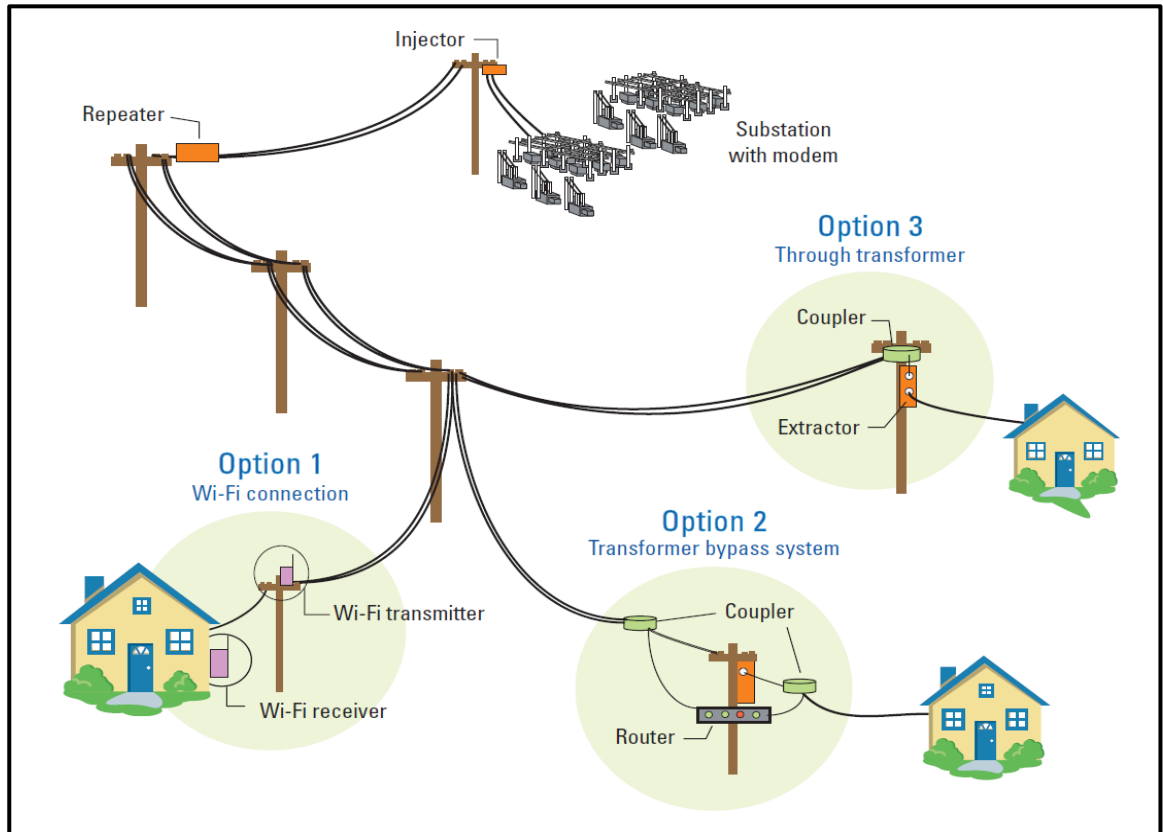

Figure.2.19. PLC with different system architecture (Gellings & George, 2004)

2.6. Modulation techniques over PLC

The used frequencies and the modulation scheme are two main factors which have a significant influence on the efficiency of the PLC system. The properties of the power line grid and its vulnerability to different types of noise requires for the best suitable modulation technique to be used in the PLC. Some of the major issues to be considered for the selecting the best modulation technique for PLC are listed below (Biglieri & Toino, 2003);

- a. The PLC channel is known as a time varying channel with frequency selectivity.
- b. Due to presence of possible electromagnetic, the transmit power in PLC systems can possibly be limited to relatively low levels.
- c. The susceptibility to various types of noise such as an impulsive noise with relatively high noise power resulting to lower SNR.

2.6.1. Orthogonal Frequency Division Multiplexing (OFDM)

OFDM is one of the multi-carrier modulation approach that transmits signals through multiple carriers (subcarriers) with different frequencies. These subcarriers are orthogonal to each other. In other word OFDM splits up the original high bit information stream into a large number of parallel lower rate information which results smaller bandwidth for the subcarriers compared with the bandwidth of the original channel. It is a combination of modulation and multiplexing (Okab, 2004).

As it is shown in Figure.2.20. in the normal Frequency Division Multiplexing (FDM) technique, the carriers are spaced apart in such a way that signals can be received by use of demodulators and conventional filters. At the receiver side, guard bands are required between the different carriers which then results in lowering of the frequency in the frequency domain. However, in OFDM system, this issue can be resolved by arranging the signal carriers in a way that the sidebands of the individual carriers overlap and the signals can still be received without adjacent carrier interference (Cowley, et al., 2002). In other word the deleterious effect of fading is spread over many bits, therefore, it is

more likely that the channel fading have slightly effects on several bits instead of a few adjacent bits being completely destroyed by the fading .The other advantage of OFDM technique is its efficient spectral usage by allowing overlapping in the frequency domain (reducing the bandwidth by squeezing subcarriers until they overlap with each other) and multi-path delay spread tolerance (Nikookar & Nathoeni, 2002)

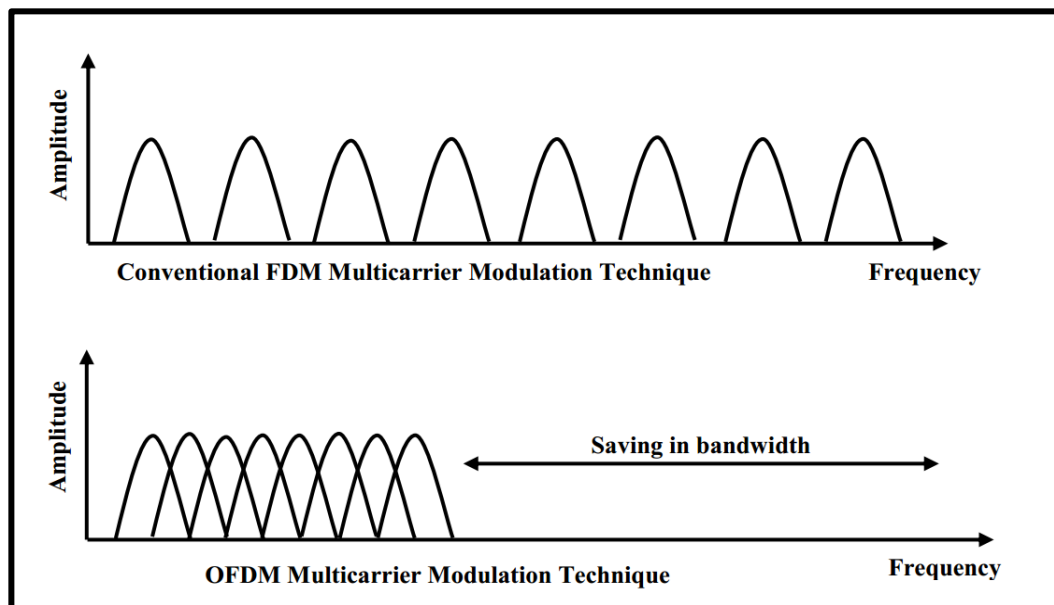

Figure.2.20. OFDM transmitted signal (Hassan, 2007)

OFDM technique has recently been applied in both wired and wireless communications systems, such as the Digital Audio Broadcasting (DAB) and the Asymmetric Digital Subscriber Line (ADSL).In this technique the probability of error in received information is reduced by dividing the channel property into a few narrowband flat fading sub-channels. In general, OFDM techniques are less sensitive to an impulsive noise compared with the single carrier techniques (Hassan, 2007).

2.6.1.1. Realization of OFDM

The information bits must undergo a number of complementary operations before they can be sent for the IFFT processing, as depicted in Figure.2.21.

One of the early steps to ensure that transmission takes place over the actual channels is coding of the primary information. The reason for this is the distortion. When there is interleaving of the encoded information, the extensive error bursts that restrict the ability of the error rectifying codes for detection and rectification of errors are curtailed. The bit-loading process is used in the more intricate OFDM system attainment. In this bit-loading, the quality of the subcarrier determines the extent of information (or bits) that can be transmitted over a certain sub-carrier. In this situation, the bit rate attained over those subcarriers that are influenced to a large extent by the disturbances is less than the bit rate attained over distortion-free subcarriers.

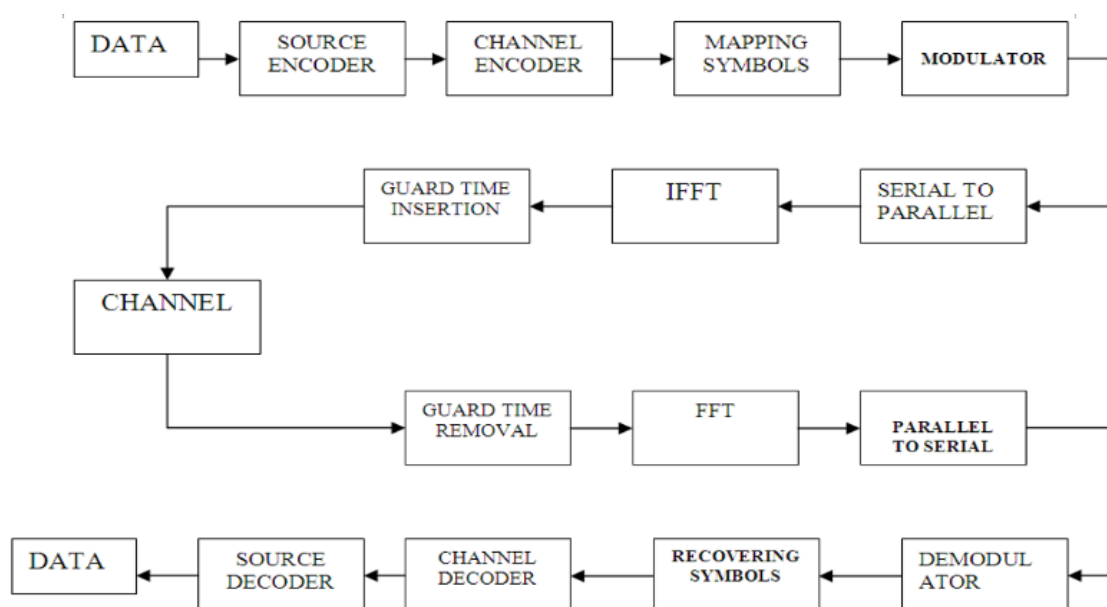

Figure.2.21. Realisation of an OFDM system (Sekhararao, et al., 2013)

2.6.1.2. Generation of OFDM signals

The OFDM symbols can be produced by dividing the data stream into several sub-streams and a subcarrier signal is used for the modulation process. The transmission takes place after the multiplexing of the signals and the inverse of the duration of the signalling symbol is used for the separation of the modulating subcarriers. The frequency multiplexed subcarriers can be independently separated. The subcarrier frequencies related to the basic idea of orthogonality, and OFDM implementation, have a zero frequency spectrum of the individual subcarriers (Cimini, 1985).

N parallel data elements are used to represent the data stream and the spacing between them is $t=1/f_s$ (f_s is the symbol rate required). N subcarrier frequencies are modulated by N serial elements and the frequency division multiplex technique is used. The symbol interval becomes Nt and it improves the delay spread which is produced by the channels. The interval separating the subcarrier frequencies is given by the equation:

$$\Delta f = \frac{1}{N \cdot \Delta t} \quad (2.16)$$

Multiples of $1/T$ are used to separate the subcarrier frequencies and the subcarriers are orthogonal in nature for the duration of the symbol. This is only possible if there are no distortions. The OFDM symbol duration is represented by T and it does not include the T_{cp} in this phase.

2.6.1.3. OFDM transmitter configuration

The configuration of an OFDM transmitter is shown in Figure.2.22. Firstly, at the transmitter side, the transmitted high speed data is converted to parallel data of N sub channels and then the data of each parallel sub channel undergoes PSK

modulation. Consider a quadrature modulated data sequence of the N channels ($d_0, d_1, d_2 \dots d_{N-1}$) and d_{In} and d_{Qn} (I and Q axis) are $\{1, -1\}$ in QPSK and $\{\pm 1, \pm 3\}$ in 16-QAM. These modulated data are then served as an input to the inverse fast Fourier transform (IFFT) circuit and then an OFDM signal is generated. Since OFDM is a low rate modulation scheme, so the symbols are comparatively long as compared to the channel time characteristics. So they don't suffer much from inter-symbol interference which is caused due to multipath. This is an advantage of using the OFDM technique as it transmits a many low rate streams in parallel rather than single high rate stream. For removing the inter symbol interference a guard interval can be introduced in between the OFDM symbols. The long duration of each symbol facilitates this insertion. This guard interval comes with lots of benefits. The sensitivity to time synchronization problems get diminished by the guard interval. The cyclic prefix is also transmitted during this interval. The OFDM signals are not stringently band limited; this is obvious from the fact that the sub-channels spread their power into the adjacent channel because of multipath fading. Each of the sub-channels can be separated and the orthogonality of the sub-channels in the absence of ISI and inter-carrier interference (ICI) can be maintained by placing an FFT circuit at the receiver end. The signals can suffer interference because of the delay of the signal with the delay time being greater than symbols time. This problem can be overcome by either increasing the number of carriers or the symbol duration. This problem however has a drawback considering the carrier stability in contradiction to FFT size and Doppler frequency. An alternate solution for eradicating ISI is inserting cyclically extended guard interval due to

which each of the symbol is followed by an extension of the signal (Sekhararao, et al., 2013).

As it has been discussed earlier the symbol consists of two parts. Thus the total symbol duration can be given as $T_{total} = T_g + T_n$, where T_g = guard time interval. This active symbol consists of the complete signal and this is also repeated at the beginning of every symbol, it is called as the guard interval. The guard interval inserted in the symbol reduces the data throughput. The ISI can be easily removed by keeping the guard interval longer than the channel impulse response or multipath delay. Conversely, the ICI still exists. Ratio of guard interval and useful symbol duration depends upon the application (Sekhararao, et al., 2013).

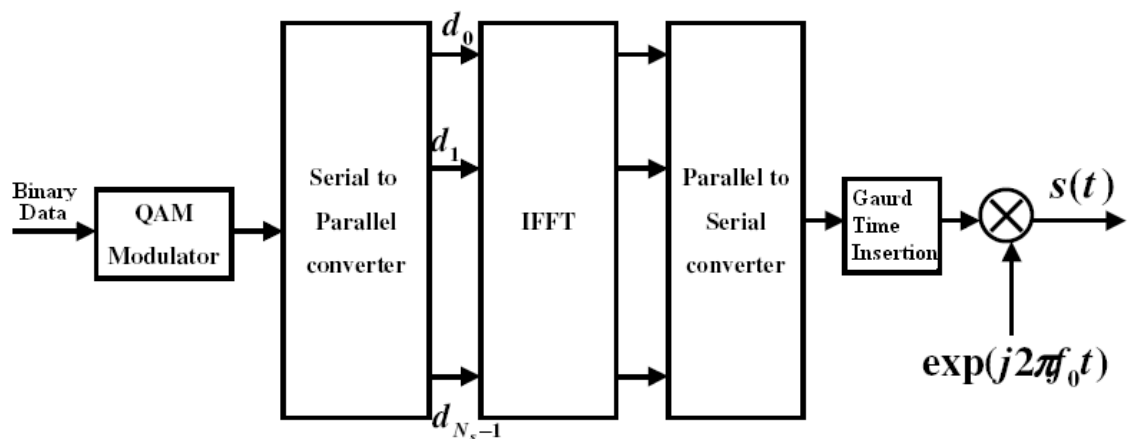

Figure.2.22. OFDM transmitter configuration (Sekhararao, et al., 2013)

2.6.1.4. OFDM receiver configuration

The arrangement of an OFDM receiver has been shown in Figure.2.23. The band pass filter is used for filtering of the received signal $r(t)$ at the receiver end. This band pass filter is expected to have a wide pass band so that it can prevent any distortion in the signal. After this the signal is down converted to FFT band using an orthogonal detector. This is followed by the FFT circuit for

attaining the Fourier coefficients during the observation. The modulation scheme of the sub channel decides the BER performance and the orthogonality is maintained in the OFDM transmission. The BER is varied with the noise of the receiver (Sekhararao, et al., 2013).

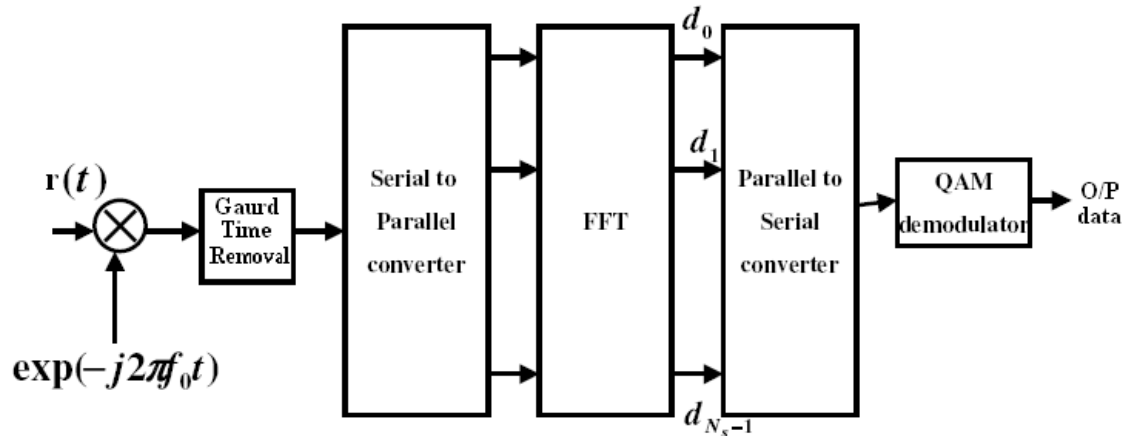

Figure.2.23. OFDM receiver configuration (Sekhararao, et al., 2013)

2.6.1.5. Coded OFDM

Coded OFDM (COFDM) refers a system with the combination of the forward error coding system and OFDM modulation technique. The major step in a COFDM technique is to interleave and code the bits prior to the IFFT. The aim is to take the adjacent bits in the source information/data and spread them across multiple subcarriers. The interleaving section at the transmitter spreads out the contiguous bits in a way that the bit errors become spaced far apart in time which makes it easier for the decoder at the receiver section to correct the errors (Katsis, et al., 2007).

2.6.1.5.1. Benefit of COFDM

COFDM systems can achieve excellent performance on frequency selective channels due to their combined benefits from coding and multicarrier modulation technique. In COFDM the inserted redundant bit into the bit stream

at the transmitter section allows great error correction codes at the receiver section, resulting a reduction in BER of the system. The more bits used for error correction the better the error correction would be, however the useful data rate is decreased (Katsis, et al., 2007).

2.7. Different types of noises effecting PLC

Normally in a power line, the source of the noise can be internal (inside the network) or external (outside the network). Overall in PLC channels the additive noise normally classified into five different classes (Chariag, et al., 2011);

- i) Coloured background noise: has very low Power Spectral Density (PSD) which also varies with the variation in frequency and resulted by summation of a number of different noise sources with very low power.
- ii) Narrow band noise: normally has sinusoidal signals with modulated amplitudes and caused by ingress of broadcast station in short wave broadcast bands and the medium.
- iii) Periodic impulsive noise asynchronous to the mains frequency: have a repetition rate between 50 kHz to 200 KHz in most cases and normally resulted by switching power supplies.
- iv) Periodic impulsive noise synchronous to the mains frequency: with the repetition rate of 50Hz or 100 Hz and are synchronous to the mains cycle and normally created by the power supplies operating synchronously with the mains cycle.
- v) Asynchronous impulsive noise: which sometimes has a very high PSD value of more than 50 dB above the background noise and is normally caused by switching transients in the network.

The first three type's noises (i-iii) are stationary over time periods and normally assumed as a background noise. The other two types (iv and v) are time variant. According to (Ma, et al., 2004) the noise modelling can be divided into;

- a) Time domain which is based on measurement of real-valued noise waveforms over the time.
- b) Frequency domain which is based on the measurement of the noise frequency spectral density.

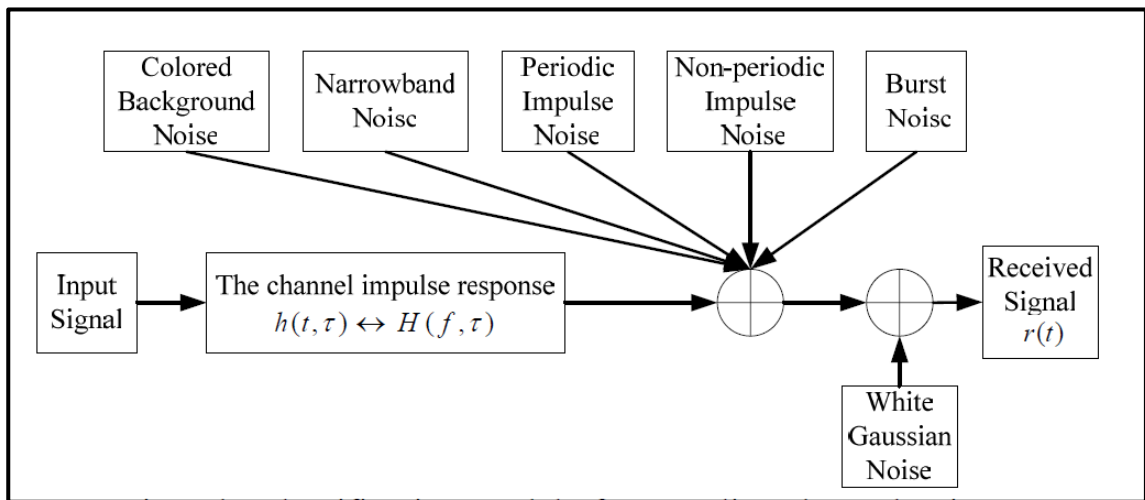

Figure.2.24. Classification of noise in PLC (Chariag, et al., 2011)

Note that the background noise can only be modelled in the frequency domain approach (it produced by very low – power noise source and its value can normally be reduced by the increasing of frequency) while the impulsive noise can be modelled in both frequency and time approaches.

2.8. Channel coding and error correction

In order to achieve reliable communication through a channel affected by noise in the digital system, the code-words required to be different from each other conspicuously enough. This difference reduces the probability of each single symbol to be taken for another symbol. The conversion of the message with this

purpose is defined as a channel coding in digital communication system. However it might cause some side effects such as an increase in needed channel bandwidth, decline of data transmission rate and an increase of complexity in the encoder/decoder (Yang, et al., 2009).

In other word the purpose of using channel coding is to encode the information sent over digital communication channel in such a way that in presence of other interferences and noise, the error can be detected and possibly corrected. There are two distinguish approaches;

2.8.1. Backward Error Correction (BEC)

This approach only deals with error detection process. In case of detecting an error, the sender is requested to retransmit the information again. This approach is very simple and has low requirements for code error correcting properties. The drawback of this technique is that it requires duplex communication, resulting undesirable delays in transmission process (Yang, et al., 2009).

2.8.2. Forward Error Correction (FEC)

One of the most commonly used techniques to enhance the quality of connection in digital communications and storage systems is the Forward Error Correction (FEC). This term refers to the rectification of transmission errors on the receiver side without requiring any further information from the transmitter. The FEC essentially seeks to involve some degree of redundancy to the information that is to be transferred, which can then be used by the receiver to adjust transmission errors that are a result of channel disturbance and noise (Hrasnica, et al., 2004).

According to Shannon's mathematical theory of communication, there is a theoretical maximum capability of every transmission channel and this is determined by the bandwidth and the SNR.

Implemented systems have a much lower capability most of the times, as compared to the largest possible value determined by the theory. This is why appropriate codes have to be used so that the bandwidth efficiency can be further enhanced (Hrasnica, et al., 2004).

According to Shannon's capacity theory, the following formula provides the highest reliable (error-free) transmission rate for channel:

Where R refers to the communication bit rate in bits per second (bps), B refers to the channel bandwidth, P denotes the transmitted power and N_0 is the power spectral density of the noise.

$$R \leq B \cdot \log_2 \left(1 + \frac{P}{N_0 B} \right) \quad (2.17)$$

The minimum E_b/N_0 needed for reliable communication can be obtained as a function of R/B by rearranging the expression given above:

$$\frac{E_b}{N_0} \geq \frac{\frac{R}{B} - 1}{\frac{R}{B}} \quad (2.18)$$

It is when R/B , referred to as "bandwidth efficiency", moves towards zero that the least value for E_b/N_0 is obtained. This gives the lowest value for E_b/N_0 beyond which it is not possible to carry out "reliable" communication. This is referred to as the "Shannon limit":

$$\frac{E_b}{N_0} \geq 10 \log_{10}(\log_e 2) \quad (2.19)$$

$$\frac{E_b}{N_0} = -1.6 \text{ dB} \quad (2.20)$$

For instance, when the bandwidth efficiency is $R/B = 1$ bps/Hz, the limit at which reliable communication occurs is 0 dB (Hrasnica, et al., 2004).

There are two key categories of FEC codes: block codes and convolutional codes, also referred to as trellis codes. Block codes include a constant amount of parity bits into a block of information bits which are of a constant length, however, convolution codes create an adjusted output bit stream that has a greater rate as compared to the input stream. These code classes are explained in this section, along with their principles, features and instances of realization.

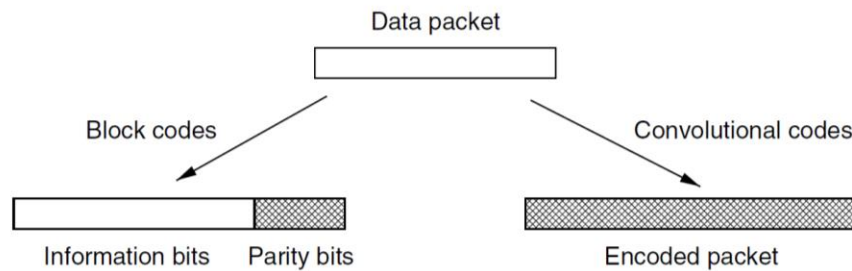

Figure.2.25. The main FEC classes: block codes and convolutional code (Hrasnica, et al., 2004)

Different codes possess different properties regarding error rectification function and decoding intricacy. Furthermore, for an actual system, design aspects like block size and scalability face practical limitations. However, the following specifications need to be fulfilled by channel codes, or at least some trade-off between them should be attained.

- To attain the highest data throughput, channel codes should have a high rate.
- To reduce the energy required for transmission, channel codes should have an appropriate bit error rate performance at the required SNR.

- Channel codes need to have less encoder/decoder intricacy so that the size and cost of the transceiver can be curtailed, and
- There should be least delays exhibited by channel codes, particularly during voice communication, so that any deterioration of signal quality is not noticeable.

2.8.2.1. Hamming code

Hamming codes are a popular simple category of block codes which are quite appropriate for low-speed indoor PLC (Dostert, 2001). Hamming codes have the ability to correct all individual errors and determine combinations of two or fewer errors in a single block (Sklar, 2001).

A Hamming code for any positive integer $m \leq 3$ has the parameters given below:

- Code length: $n = 2^m - 1$
- Number of information symbols: $k = 2^m - m - 1$
- Number of parity symbols: $n - k = m$
- Error correction ability: $t = 1$, since $d_{\min} = 3$.

Figure 2.26. Illustrates the representation of the hamming code. The three big circles in this figure represent the three parity check equations defining the hamming code and the seven small regions are representing the seven bits in a codeword. The hamming equation requires an even numbers of ones in each big circle. If not, there is an error. If an error is a single error, depending to its location it can be fixed by flipping a single bit in the appropriate region. In practice codes used are longer and more complicated, but the basic principle is the same. There are different way of employing redundancy bit for error

correction. Although researchers are still looking for some new ways but up to now the hamming code is known as more efficient than others (Aydin, 2007).

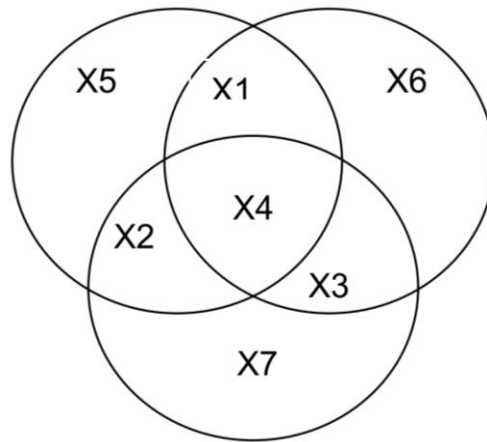

Figure.2.26. An alternative description of the Hamming code (Aydin, 2007)

2.8.2.2. Turbo coding system

The first turbo code, based on convolutional encoding, was introduced in 1993. Many schemes have been introduced over the years and the turbo codes now refer to the block codes and the convolutional codes. When an interleaver separates two codes and a parallel concatenation of these codes takes place, the turbo code is produced (Berrou, et al., 2003).

It is shown in the Figure.2.27. that the turbo code's generic design which are usually developed according to the concepts in (Berrou, et al., 2003), but the selection of the encoders and the interleaver can also be done freely;

- Identical encoders are commonly used.
- The output contains the input bits and a systematic representation is chosen for the code.
- The order in which the bits are read is pseudo random.

The design of the turbo code is greatly influenced by the type of interleaver which has been selected (Käsper, 2005). An interleaved input into the second

encoder makes its output different from the output of the first encoder a low weight code word at one of the outputs does not ensure a low weight code word at the other output. A decoder works efficiently with higher weight code words and the divide and conquer strategy can be used for the decoding problem because a parallel concatenation is used for the two codes. A scrambled input in to the second decoder will produce a different output and there will be no correlation with the first encoder's output and the two decoders involved will benefit from the exchange of data (Käsper, 2005).

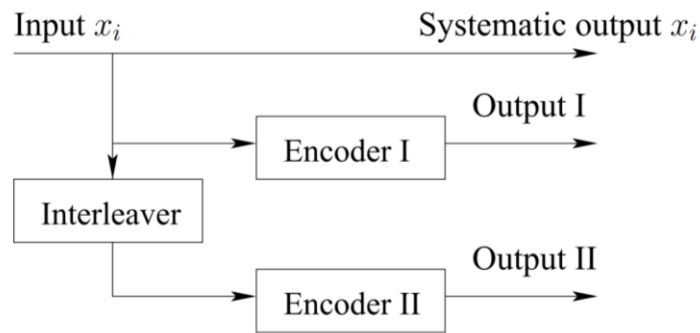

Figure.2.27. The generic turbo encoder (Käsper, 2005)

2.8.2.3. Trellis Coded Modulation (TCM) concepts

2.8.2.3.1. Euclidean Distance

An Euclidean distance is a straight line (shortest distance) between any two constellation points. For instant for two points $P_1 (x_1,y_1)$ and $P_2 (x_2,y_2)$ the Euclidean distance can be defined by familiar formula (Langton, 2004):

$$\sqrt{(x_1 - x_2)^2 + (y_1 - y_2)^2} \quad (2.22)$$

The Euclidean distance is an analog concept. For signals the Euclidean distance can be defined in I and Q plane. Euclidean distance can also been

used between sequences by comparing distances between corresponding points of the sequences (Langton, 2004).

2.8.2.3.2. Hamming distance

Hamming distance is a distance between two binary numbers. For instance the hamming distance between two binary numbers 011011 and 101101 is the number of places these two numbers differ. i.e the hamming distance is 4. In case of two digital numbers with the same patterns the hamming distance would be zero (Langton, 2004).

2.8.2.3.3. Trellis Coded Modulation (TCM)

The term of TCM is a combination of coding and modulation technique and the word of Trellis stands for using trellis code.

As it can be seen in Figure.2.28. the coding system adds just one extra bit to the symbol bit size. The symbol size increases from k bits to k + 1 bits. If the coding increases the bit rate by 1 extra bit, the constellation size need to be doubled to accommodate this bit as it can be seen below:

$$2^{L+1} = 2 \times 2^L \quad (2.23)$$

L is the original number of bits per symbol. So if the original signal is BPSK, then the output from the TCM encoder will be QPSK. If the original signal is QPSK the output will be 8PSK and if 8PSK was selected then the output will be 16QAM.

As it can be seen in Figure.2.28. by varying a number of bit (k) in TCM system, QPSK, 8PSK or any other higher signal can be created (Molisch, 2012).

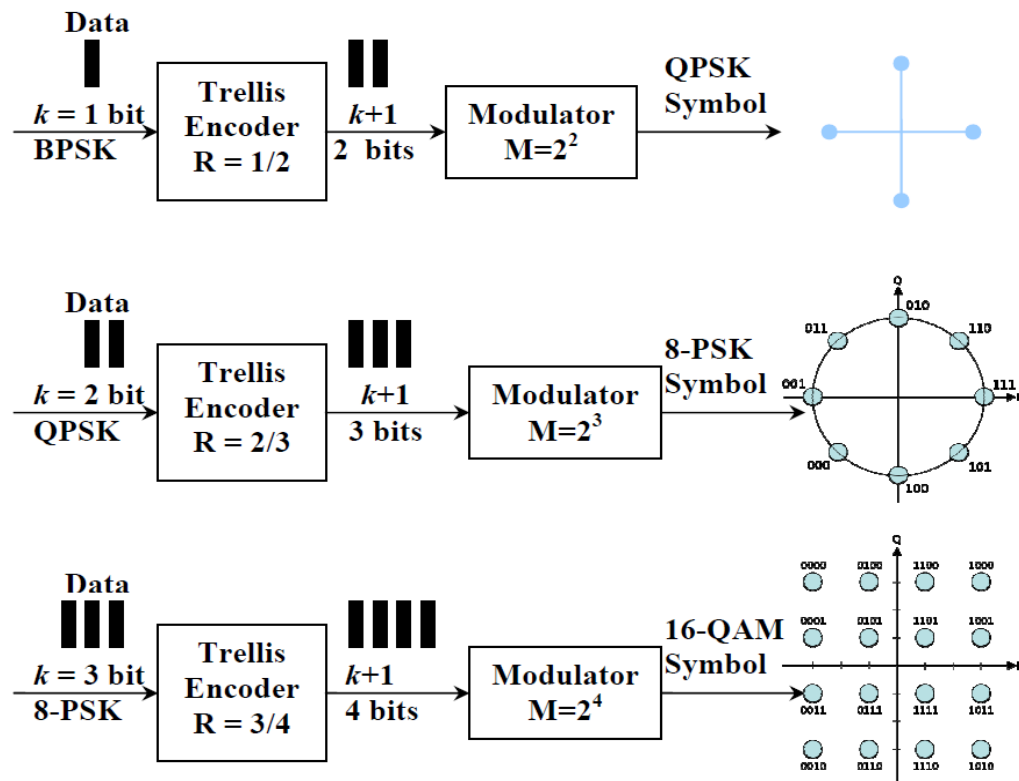

Figure.2.28. General TCM system with various code rate and out puts (Molisch, 2012)

As the constellation increases the signal energy remains the same, but the distance between the symbols is reduced and this decreases the performance of the system.

A few key benefits of using the TCM method are as follows (Molisch, 2012):

- The TCM functions as bandwidth efficient modulation since it makes use of convolution coding and also multiplies the number of constellation points of the signal. This also leads to an improvement in bit rate with the symbol rate staying the same.
- All incoming bits do not undergo coding, which is in contrast to a true convolution coding system.

- When the constellation size is increased, Euclidean distances between the constellation points are decreased, however, there is a sequence coding which counters the power drawback of moving towards the increased constellation.
- It is possible to determine performance by coding gain over un-coded signals.
- It is not the Hamming distance that is the decoding metric; rather it is the Euclidean distance.
- The TCM was initially put forward by Ungerboeck which employed set-partitioning and fewer states that had code rates that were in accordance with the kind of input signal.

2.9. Transformers

The transformers have a complex effect on the propagation of high frequency signals. A shunt capacitance connected to a transformer experiences a short circuit in case of high frequency signal. The shunt capacitance is connected in parallel to the inductance and it causes resonance and high impedance for certain frequencies. So as a result, the transmission of these high frequency signals is a very strong function of the frequency. The attenuation values range from 10 to 20 dB across the transformer of these high frequency signals and the attenuation values depend on the frequency.

There are no recently updated references about the impedance of power transformers at different carrier frequencies. The discussion, below, on the topic is completely general and based on past experiences. However, the results may completely differ.

Power transformers are considered as high shunt impedance at carrier frequencies. Their effect on the carrier channel performance depends on their location in the carrier channel. A power transformer that connects two transmission lines of different voltage levels is accepted to constitute a blocking device of broad band high frequency that prevents carrier frequency to travel from one line to another. Hence, a power transformer at the terminal location of the carrier channel appears as a trap to the carrier signal.

Extractors can be used to retransmit the signal when PLC signals loses their strength as they pass through the transformers. In addition couplers can also be used in LV and MV to bypass the transformers and deliver the signal to customers.

2.10. Electromagnetic compatibility of PLC systems

The power grid is used to transfer information signals in the PLC technology. When the electrical PLC signal is included in the power cables, there is radiation of an electromagnetic field in the environment, and the power cables start functioning like antennas. This field appears to serve as a disturbance for the environment, and hence, it is prohibited to go beyond a certain prescribed level so that *electromagnetic compatibility* is attained. This means that the PLC system needs to function in an environment without upsetting the working of other systems present in the same environment (Hrasnica, et al., 2004).

This research does not take into account deep consideration of EMC because several other noises are assumed to be interferences.

2.11. Security of power line communication

One of the major issue in any telecommunication system is a Security. This is even bigger issue in the case of using a shared medium/channel such as a power line channel. However, in theory the PLC system is more secure compare to the wireless system due to the fact that the physical medium of power line channel is not easy to get accessed. For instance, with suitable tools, the Wi-Fi system which uses a shared channel with its accessibility for people in the coverage area the network traffic can possibly be intercepted and even any electronic device connected to the network can also be reconfigured (Al Mawali, 2011).

Another advantage of security aspect for PLC is its potential for involved danger due to the presence of the AC electrical signal (Carcelle, 2006).

Although in theory the power line systems are more resistant to attacks, but they are not fully protected and need some software security to reach to the acceptable security levels against possible attacks such as an (Al Mawali, 2011);

- a) attacks for damaging the available working network
- b) attack to prevent the system operation,
- c) attack that aims to access to the devices connected to the network

These possible treat can possibly be countered by use of (Al Mawali, 2011):

- a) **Authentication** is one of the possible software security approach that can possibly be used in PLC system as well as any other wired/ wireless systems. This security approach authorise the user to access to the network only after identifying the user.

- b) **Cryptography** is an approach that can be used in PLC network to deny hackers access to the information in the network. An encryption key is used to encode the information before transmission through the channel. The encoded information makes the signals incomprehensible to the hackers. A decoding key then required to retrieve the coded information carried in the signal at the receiver side.
- c) **Integrity control** is used to identify if the sent information through the power line network has been modified during transmission. Electronic signatures can be used to check if the received information has been any changed or modified during the transmission over the power line networks.

2.12. Feasibility of power line communication

The feasibility of PLC system has been investigated in (Fink & Jeung, 2008). Due to importance of energy for living, electricity are ever-present in most of the residential (urban and rural) areas compared to telephone systems. Therefore, it would be a good idea to provide high speed data to consumers at their homes as it comes cheaper compare to providing high speed data with the coaxial or telephone cables. Especially in areas where a DSL or a cable is not available, power line grid can be a cost effective connectivity solution.

Obviously, using an existing infrastructure for high speed data transmission would be a great reduction in the network deployment cost.

The feasibility of such a system has been investigated for a few countries. In rural areas the provision of the PLC system for data transmission in place of the current alternative technologies (wireless/satellite) ,such as a backhaul and last mile, has been considered.

From the technological perspective, the basic idea of PLC system is just to modulate a radio signal with data and send it through the power lines in a range of frequencies which are not used for supplying electricity. As it was mentioned earlier, the frequencies used and the encoding approach have a significant influence on the efficiency and the speed of PLC technology. From the customer's perspective, the equipment needed to set up PLC in the building (home/office) is cheaper compared to other broadband solutions such as cable and DSL modems due to the need for additional wiring or installation.

Although the PLC system does not appear to represent the major distribution technology in competitive markets, it is very suitable for rural areas and can be considered as the major strategy for future policy. In addition any progress in the PLC system with high speed data transmission can be a great aid for the transmission of narrow band system such as those used in smart meter technologies (gas and electricity). (Fink & Jeung, 2008).

2.13. Summary

This chapter provides a brief overview about the historical developments of PLC systems and also a literature survey covering all the aspects of a PLC system. The structures of power line systems, their physical properties and applications were explained. In addition, the chapter outlined the available models for a PLC channel and sources of noise. Different modulation techniques and their applicability in PLC were also reviewed to enable the reader to identify which modulation approach is more suitable for the PLC system. The superiority of OFDM and the need for adaptive modulation have been described. Various Channel coding techniques were also reviewed.

A short overview about the security of the PLC technology was provided. In addition a survey of the past, current and future PLC standards were included. The chapter ends by reviewing feasibility of the PLC system.

Chapter 3

Data Transfer over Power Distribution Networks

3.1. Introduction

PLC communication systems are fast emerging as a cost-effective solution for broadband access networks. As it was discussed earlier the main advantage of a PLC system is to use the existing infrastructure of power line networks for providing data network services to customers in areas without access to wired medium such as telephone or fibre optics cables. (Zimmermann & Dostert, 2002). The high data rate signal undergoes attenuation due to line loss and impedance mismatches of the power line elements such as branches and loads. In addition, these elements are a source of noise and interference in the transmission medium. The topology of the PLC system can vary according to distribution network in use (Chandna & Zahida, 2010). This section discusses a typical topology of the distribution network where a LV European power line is used as the transmission channel. The topology of the LV distribution network may differ from country to country and even from region to region. It is dependent on several factors such as user density, the distribution network length, location (commercial or residential) and the topological designs (the length of the branch, number of branches, etc.). In this section a multipath power line channel has been modelled using Matlab and the effects of variations in the direct length, branch length and branch load on the channel frequency response are investigated. A power line with typical European

specifications is considered (Ferreira, et al., 2006). Results and information in this chapter has been published in IEEE conference paper (Hosseinpournajarkolaei, et al., 2012).

3.2. Transmission line model

There are different methods to study and simulate the transmission line behaviours. Most of these methods are obtained from the time dependent telecommunication equations which are for the elementary line transmission cell, as it is shown in Figure.3.1:

Where;

x represents the longitudinal direction of the line,

R' is per unit length resistance (Ω/m),

L' is an inductance with unit of (H/m),

G' is the conductance of the line (S/m) and

C' is the capacitance with unit (F/m).

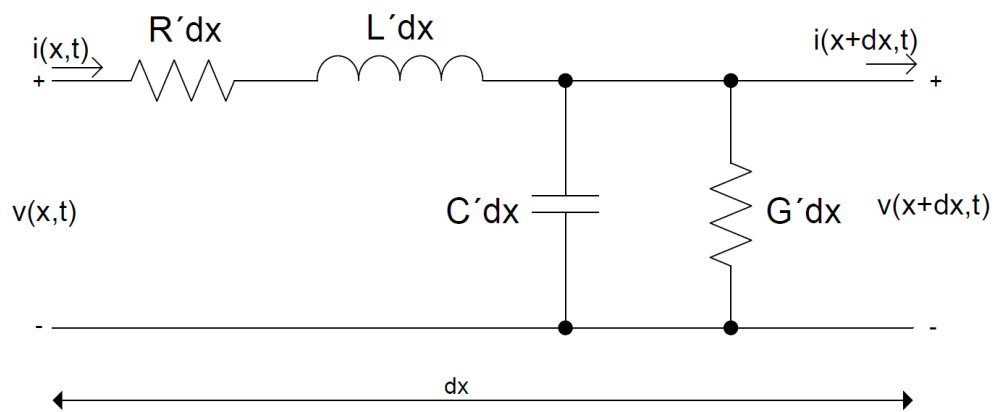

Figure.3.1. Elementary cell of a transmission line (Mlynek, et al., 2010)

$$\frac{\partial v(x,t)}{\partial x} + R' i(x,t) + L' \frac{\partial i(x,t)}{\partial t} = 0 \quad (3.1)$$

$$\frac{\partial v(x,t)}{\partial x} + G' v(x,t) + C' \frac{\partial v(x,t)}{\partial t} = 0 \quad (3.2)$$

The electric quantities are normally geometric and also constitutive dependent. The channel characteristic impedance Z_c and the propagation constant γ are the two main parameters to describe a transmission line which are given as (Mlynek, et al., 2010):

$$Z_c = \sqrt{\frac{R' + j\omega L'}{G' + j\omega C'}} \quad (3.3)$$

$$\gamma = \alpha + j\beta = \sqrt{(R' + j\omega L')(G' + j\omega C')} \quad (3.4)$$

the transfer function of the line with the length l can be defined as:

$$H(f) = \frac{V(x=l)}{V(x=0)} = e^{-\gamma l} = e^{-\alpha(f)l} e^{-j\beta(f)l} \quad (3.5)$$

3.3. Power distribution networks

As HV lines are not suitable for data transfer, conventional fibre optics or wireless radio-links are used for transmission of data over the existing power lines with repeaters used in MV networks to mitigate the effects of noise interference. Couplers then can be used to by-pass transformers when the power is lowered from MV to LV. In (Anatory, et al., 2007) the effects of changes in the power distribution network topologies on the power line channel frequency response are investigated for systems used in Tanzania. This section investigates the effects of variations in the direct length, branch length, number of the path and branch load on the LV power line channel frequency response for European power distribution networks. A simple topology for such a power distribution network is shown in Figure.3.2. The length of the power line between the transmitter and the receiver is AC . The branch length is given by

BD, where B is assumed as the midpoint of AC. The source and load impedances are given by Z_s and Z_l respectively.

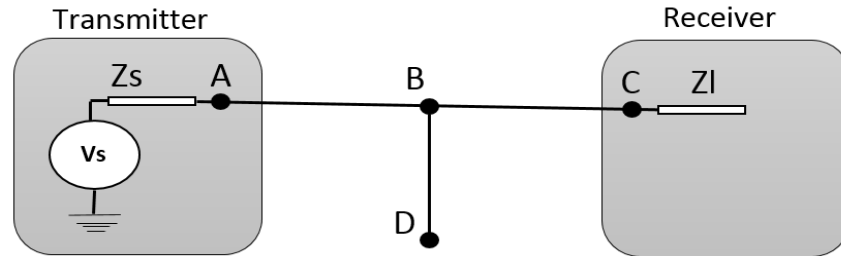

Figure.3.2. A LV power line network configuration

According to (Ferreira, et al., 2006) the characteristic impedances of the power lines are connected in parallel. A typical indoor power line has characteristic impedance value which lies between 40-80 Ω . Therefore, a house connection, with 10 lines connected in parallel, has approximately a 4 Ω equivalent impedance. However, in practice the number of lines connected in parallel will be larger, thus causing the equivalent impedance to be close to zero at this point. In this investigation, the type of the cable used is NAYY150SE (cable specification, R' , L' , G' , C' , Z_c and γ parameter, has been taken into account).3.4. Channel model for power line communication.

The various power line channel models available are the Zimmermann and Dosteret model, Philipps model and the Anatory et al. model (Anatory, et al., 2007). The multipath model proposed by Philipps and Zimmermann is a widely used model for investigating the data transmission over power lines. Where $H(f)$ is the frequency response of the channel and the various parameters used in equation (3.6) are given in Table.3.1. The weighting factor g_i and the length of the data transmission path d_i for various path numbers is given in Table 3.2. where N is the total number of paths.

$$H(f) = \sum_{i=1}^N g_i \cdot e^{-(a_0+a_1 f^k) d_i} \cdot e^{-j2\pi f \frac{d_i}{v_p}} \quad (3.6)$$

Parameter	Description
i	Number of the Path. The path with the Shortest delay has the index $i=1$
a_0, a_1	Attenuation parameters
k	Exponent of the attenuation factor (usual values between 0.2 and 1)
g_i	Weighting factor for path i , in general Complex, can be physically interpreted as the Reflection/transmission factors of that path
d_i	Length of path i
t_i	Delay of path i

Table.3.1. Model parameters of the transfer function

3.5. Simulation results

A distribution network topology with one branch and segments (1),(2) and (3) with the length l_1 , l_2 and l_3 and also characteristic impedance Z_{C1} , Z_{C2} and Z_{C3} is presented in Figure.3.3.

The transmitter and receiver are impedance matching. This means $Z_A=Z_{C1}$, $Z_C=Z_{C2}$. The appliance on the branch BD has different impedance than the cable which then causes the reflection.

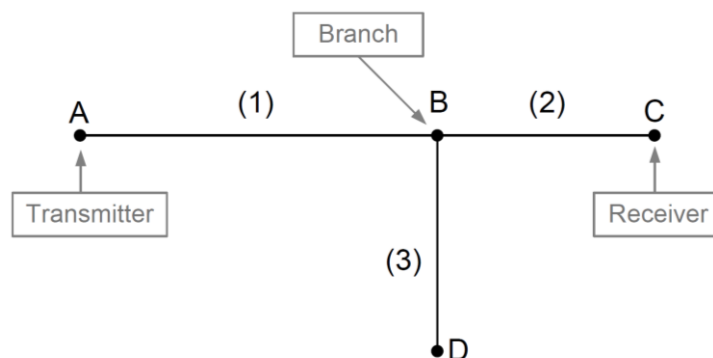

Figure.3.3. Topology of sample network

Based on the parameters on the topology of the distribution network, the characteristic impedance, propagation constant and reflection factors for each network segment can be calculated.

Due to the difference in impedance of the cable and the branch, there would be the reflection points B and D with the reflection factor of r_{1B} , r_{3D} , and r_{3B} (Mlynek, et al., 2010) & (Zimmermann & Dostert, 2002).

$$\Gamma_{1B} = \frac{\frac{Z_{C2} \cdot Z_{C3}}{Z_{C2} + Z_{C3}} - Z_{C1}}{\frac{Z_{C2} \cdot Z_{C3}}{Z_{C2} + Z_{C3}} + Z_{C1}} \quad (3.7)$$

$$r_{3D} = \frac{Z_D - Z_{C1}}{Z_D + Z_{C1}} \quad (3.8)$$

$$r_{3B} = \frac{\frac{Z_{C2} \cdot Z_{C1}}{Z_{C2} + Z_{C1}} - Z_{C3}}{\frac{Z_{C2} \cdot Z_{C1}}{Z_{C2} + Z_{C1}} + Z_{C3}} \quad (3.9)$$

From (3.7) – (3.9) the transmission factor, t_{1B} and t_{3B} , can be calculated (Mlynek, et al., 2010);

$$t_{1B} = 1 - |r_{1B}| \quad (3.10)$$

$$t_{3B} = 1 - |r_{3B}| \quad (3.11)$$

Each of these i possible propagation paths from transmitter to receiver has a weighting factor g_i which is the product of the transmission factor and the reflection (Mlynek, et al., 2010).

The delay τ_i of a path can be calculated from the length d_i , the speed of light c_0 and the isolation relative permittivity ϵ_r (Mlynek, et al., 2010):

$$\tau_i = \frac{d_i \sqrt{\epsilon_r}}{c_0} \quad (3.12)$$

The possible propagation paths from transmitter to the receiver are shown in Table.3.2.

Path No	Pathway	Weighting factor g_i	Length of Path d_i
1	A→B→C	t1B	L1+L2
2	A→B→D→B→C	t1B.r3D.t3B	L1+2L3+L2
-	-	-	-
-	-	-	-
N	A→B(→D→B) ^{N-1} →C	t1B.r3D.(r3B.r3D) ^{N-2} t3B	L1+2(N-1).L3+L2

Table.3.2. Signal propagation paths of the examined network

This section gives the simulation results for the effects on the frequency response of the LV power line channel due to variation in length for the direct line with and without a branch; variation in length and load for the branch BD. The simulations are undertaken in Matlab 2013b.

3.5.1. Variation in the direct line length from the transmitter to the receiver

The topology in Figure.3.1 without a branch BD was employed to investigate the effects of change in the direct line length on the power line channel i.e. $N=1$. The length AC between the transmitter and the receiver was varied as 100m, 200m, 400m and 800m. Points A and C are matched with the characteristic impedance of the cable. The frequency response of the power line channel is shown in Figure.3.4. It is observed that the direct line channel topology exhibits no reflection points, i.e. there is no multi-path fading as the channel response is

a linear function of the frequency. The receiver can, therefore, recover the data transmitted using a single-carrier modulation transmission. As the length of the direct line increases the channel bandwidth decreases indicating a direct line length of up to 100m is suitable for data transmission up to 10 MHz, even though the European specifications indicate a maximum length of 1 Km for power transmission for the length AC (Hosseinpournajarkolaei, et al., 2012).

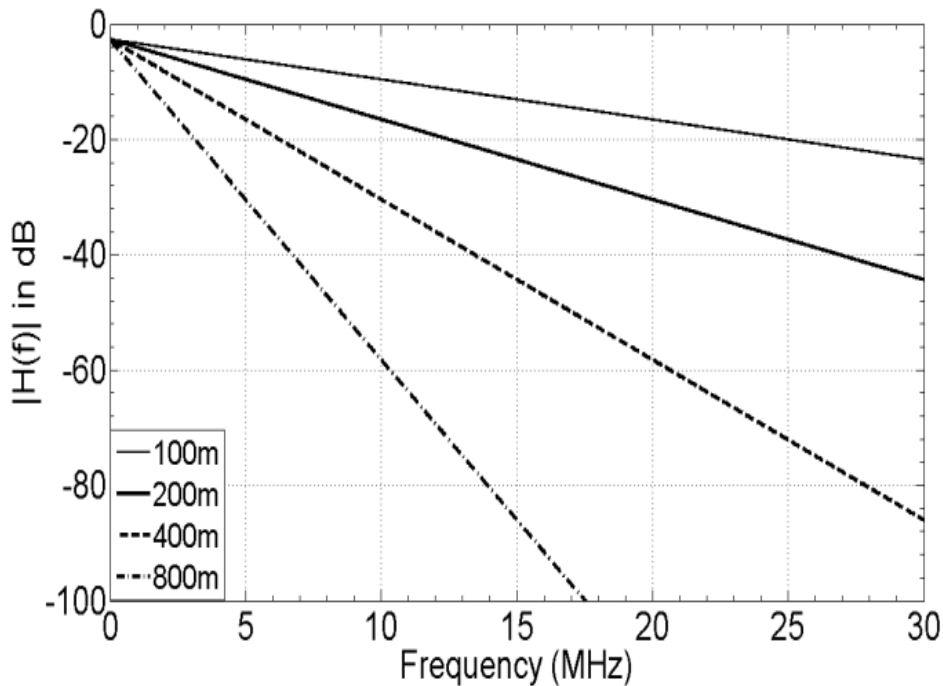

Figure.3.4. Frequency response for LV channel, effect of the direct length from transmitter to receiver (AC varies as 100m,200m,400m,800m) , $Z_L=Z_s=50\Omega$

3.5.2. Effect of varying the length AC with one branch

The direct line length AC was varied as 100m, 200m, 400m and 800m with a single branch BD at constant length of 20m, i.e. $N=2$. The point D was left open leading to a reflection factor equal to 1. The multi-path behaviour of the power line channel can be observed as the notches in the frequency response and is shown in Figure.3.5.

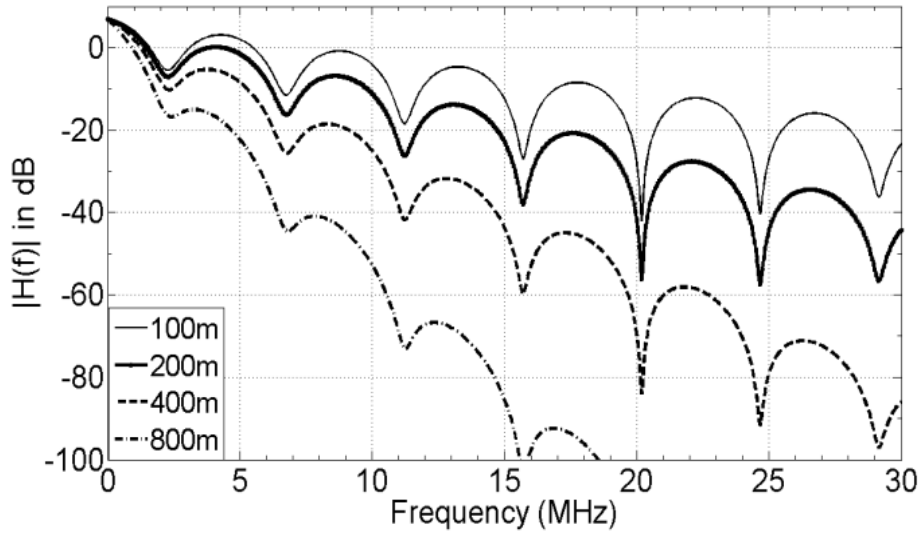

Figure.3.5. Frequency response for the LV channel with one branch; effect of varying the length of AC with one branch BD of 20m. AC varies as 100m, 200m, 400m, 800m.

The multi-path behaviour in Figure.3.5. indicates that multi-carrier transmission would be suitable for data transmission over the power line channel with this topology. As each frequency notch is spread over a spacing of 5 MHz, each sub-carrier therefore would be required to have a maximum bandwidth of 5 MHz to ensure frequency flat fading. The increase in the direct line length AC reduces the channel bandwidth and its effect on frequency response is similar to the no-branch case, the difference being that the frequency notches are superimposed on the frequency response in Figure.3 4.

3.5.3. Effect of varying the branch's length

The length of the branch BD was varied from 10m to 100m, while the transmitter-receiver length AC was kept constant at 100m. The branch BD was terminated at a typical value of 70Ω. The effects of change in BD with AC kept constant at 100m are shown in Figure.3.6. From Figure.3.6 it is observed that increasing the branch length BD increases the power line attenuation which is

especially noticeable in higher frequencies (Hosseinpournajarkolaei, et al., 2012).

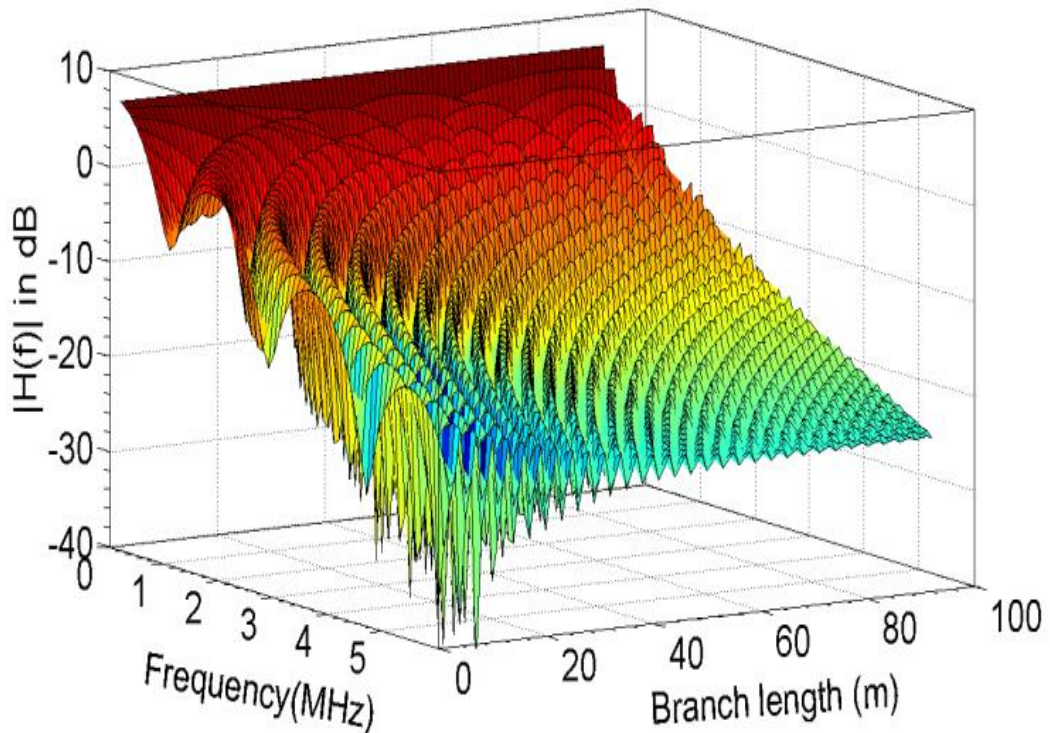

Figure.3.6. Variation in the frequency response for the LV voltage channel with change in branch of length.

3.5.4. Effect of varying the branch's load

The frequency response for the branch load values of 40Ω and 80Ω is shown in Figure.3.7. The direct line length AC and the branch length BD were kept constant at 100m and 20m respectively. The branch load considered is at the termination point D of the branch. It observed from Figure.3.7 there is marginal change in the frequency response as the branch load is changed from 40Ω to 80Ω .

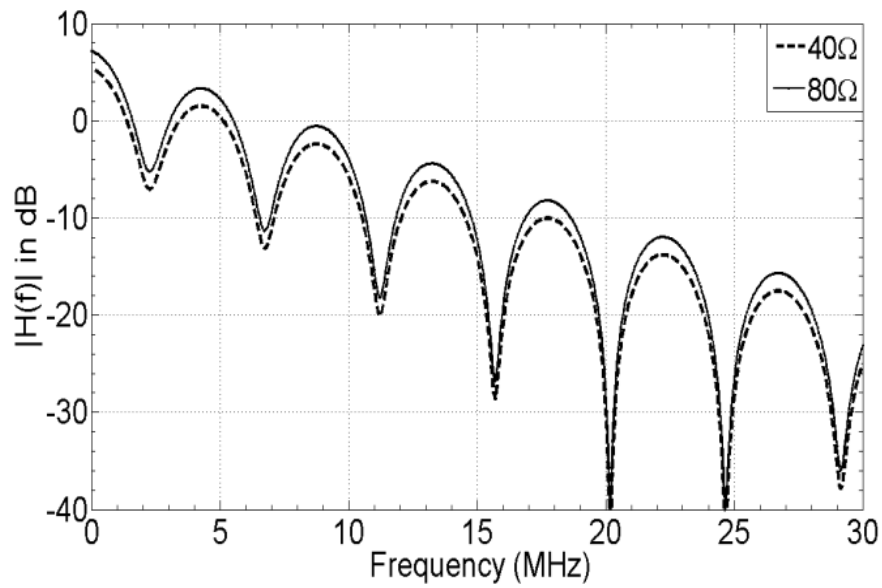

Figure.3.7. Variation in the LV channel frequency response with change in branch from 40Ω to 80Ω .

3.5.5. Effect of varying number of the path

In case of multipath with different numbers of paths, from the simulation results for number of path 4 and 10 shown in figures below, it can be observed that the position of notches do not change. But as the number of paths increases from 4 to 10 the attenuations of notched points and signal distortion tend to increase.

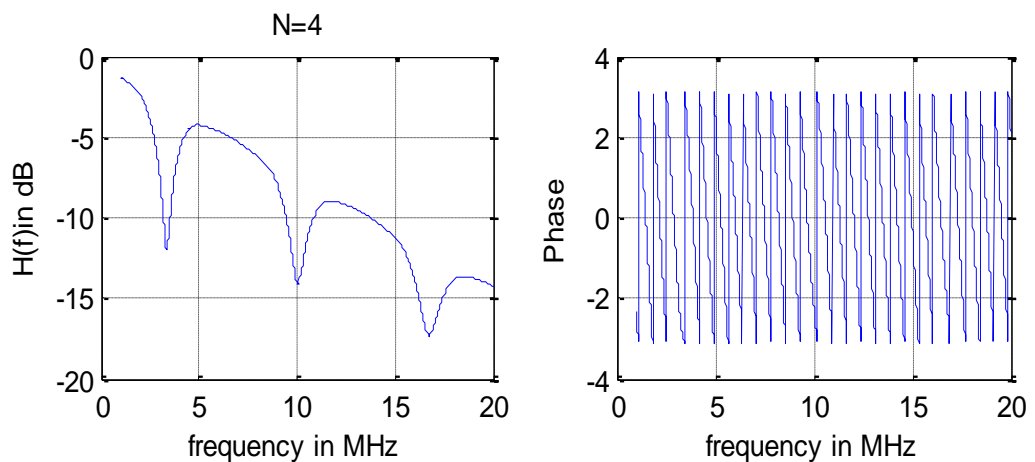

Figure.3.8. Multipath channel model with number of path=4.

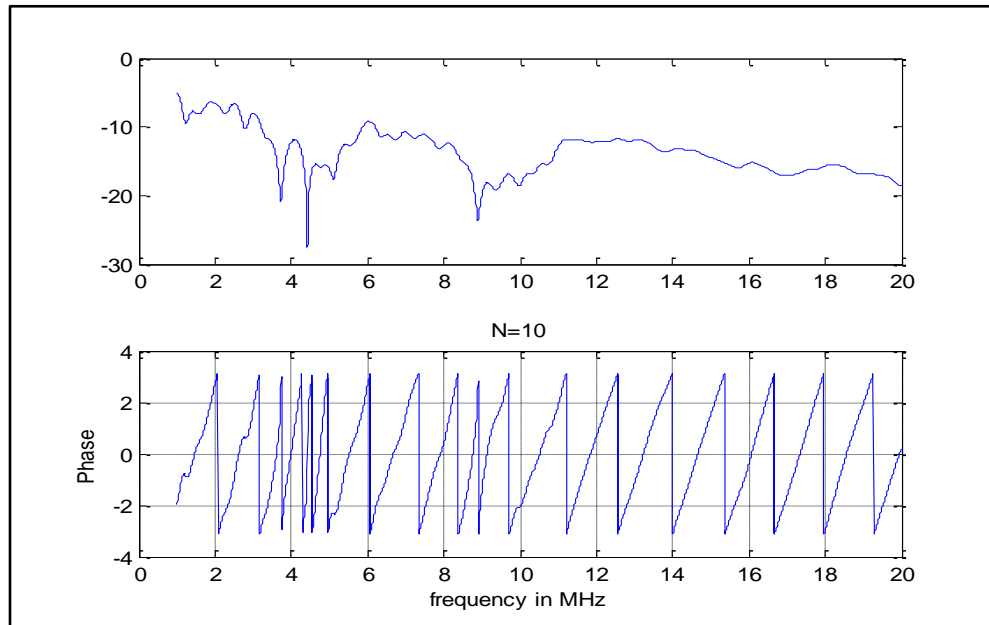

Figure.3.9. Multipath channel model with number of path=10

3.6. Summary

Various studies undertaken in Africa have indicated that PLC systems can use the existing LV power distribution networks as the 'last mile' alternative for network data transfer. In this chapter the channel frequency response for the European LV power distribution networks is investigated. The frequency response indicates a multi-path transmission which is as expected due to various branches present in the transmission path. Multi-carrier transmission therefore is a suitable transmission scheme for data transfer over such networks. The effects on the frequency response for more complex topologies for power distribution networks, including different noise interferences is been investigated and is presented in later chapters.

Chapter 4

Bit Error Rate Performance in Power Line Communication Channels with Impulsive Noise

4.1. Introduction

Noise can be defined as an unwanted signal that interferes with measurements, communication, perceptions, and processing of information bearing. The noise itself is also considered a signal which contains the information regarding the source of the noise. There are several sources of noise which may be inherent in electrical current flows, interferences due to varying levels of impedance and attenuation, thermal noise intrinsic to electric conductors or many more. In a digital communication system, the data transmission capacity becomes limited due to presence of noise amongst several other issues such as attenuation and multipath effects. Hence, it is highly recommended to carry out a thorough analysis on the modelling and removal of noise within general data communication systems and particularly for power line communications. (Vaseghi, 2006)

Noise has a significant effect on data transmission in PLC systems. Several noise sources are responsible for the noise present in the PLC. The channel between any two outlets in any building has a transfer function with a complex transmission line network and several stubs that terminate loads of several impedances. The phase and amplitude responses of these systems fluctuate extensively with frequency. Some signals may be distorted by the noise or some frequencies may observe little attenuation in the transmitted signal.

Furthermore, the PLC channel transfer function has a time varying characteristic due to the fact that at any point of time, the consumer may plug a new electrical device into the electrical power line or some appliances may consist of time-varying load impedance. This is mostly caused by small electrical motors or switching power supplies. Impulsive noise is induced into the power line channel when inadequately designed switching power supplies are connected to the power grid system. These power lines consist of high harmonic content that is linked with the supply switching frequency. Hence, the power line channel presents a non-Gaussian noise environment due to its noise diversity consequence (Anon., 2003).

The PLC channel noise can be divided as impulsive and background noise as stated in (Zimmermann & Dostert, 2002). Stationary characteristics are present for background noise, but for impulsive noise there are short intervals that have a high power spectral density (PSD) of up to 40 dB existent above the background noise. Due to this impulsive noise is the main source error for data transmission over power lines. It is more difficult for PLC transceivers to handle the impulsive noise in comparison with background noise. The disturbance does not affect data when the disturbance is shorter than the transmitted symbol duration. However, in an opposite situation, the data would be distorted by noise.

A mathematical model for impulsive noise in PLC systems is useful for providing relevant solutions for data transmission.

4.2. Impulsive noise modelling

The digital and analogue mathematical concepts have been presented as part of this section. In Figure.4.1(a) the unit-area pulse, $p(t)$, is defined. The pulse transforms into an impulse since the pulse width tends to zero. In Figure.4.1(b), the impulse function is shown as a pulse with an infinitesimal time width, whereas figure.4.1.(c) shows the spectrum of the impulsive function. (Vaseghi, 2006).

$$\lim_{\varepsilon \rightarrow 0} p(t) = \begin{cases} 1/\varepsilon, & |t| \leq \varepsilon/2 \\ 0, & |t| > \varepsilon/2 \end{cases} \quad (4.1)$$

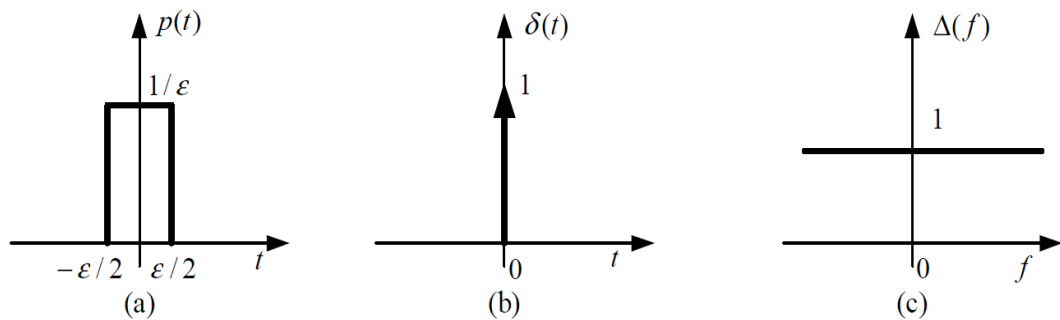

Figure.4.1.

(a) An unit-area pulse

(b) The pulse transforms into an impulse since $\varepsilon \rightarrow 0$;

(c) the spectrum of the impulsive function.

The integral impulsive function is presented as follows:

$$\int_{-\infty}^{\infty} \delta(t) dt = \varepsilon \times \frac{1}{\varepsilon} = 1 \quad (4.2)$$

The Fourier transform of the impulse function is presented as follows:

$$\int_{-\infty}^{\infty} \delta(t) e^{-j2\pi f t} dt = e^0 = 1, -\infty < f < \infty \quad (4.3)$$

Where the frequency variable is denoted as f .

A signal with an 'on' duration of a single sample is known as the digital impulse, $\delta (m)$. It can be stated as:

$$\delta (m) = \begin{cases} 1, & m = 0 \\ 0, & m \neq 0 \end{cases} \quad (4.4)$$

Where the discrete-time index is denoted as m . The frequency spectrum of digital impulse, with the help of the Fourier transform relation, is given by.

$$\sum_{-\infty}^{\infty} \delta(m) e^{-j2\pi m} = 1, -\infty < \omega < \infty \quad (4.5)$$

In communication systems, a real impulsive-type noise has a duration that is usually more than a single (one) sample long. This impulsive noise origination takes place from within space and time, then propagates from the channel to the receiver. The characteristics of impulsive noise include the random positions of occurrence, binary-state sequence of impulses with random amplitudes and non-stationary. The non-stationary nature of impulsive noise can be seen by considering a few impulses per second of the power spectrum of the noise process. In case of the noise being absent, the process has zero power, and when an impulse is present the noise power is the power of the impulse. Hence, it can be stated that the power spectrum and autocorrelation impulsive noise is a time-varying and binary state process (Vaseghi, 2006).

4.2.1. Statistical models for impulsive noise

The statistical models that help with the characterization of impulsive noise is presented in this section. The characteristics of impulsive noise includes $n_i(m)$ which consists of short duration pulses of random amplitudes, durations and times of occurrence. Its model has been presented as the output of a P-tap filter (Vaseghi, 2006):

In this case,

- h_k is the impulse response of a filter that models the duration and the shape of each impulse
- $n(m)$ is a continuous-valued random process that models the impulse amplitudes
- $b(m)$ is a binary-valued random sequence modelling the time of occurrence of impulsive noise.

$$n_i(m) = \sum_{k=0}^{P-1} h_k n(m-k) b(m-k), \quad (4.6)$$

The Bernoulli-Gaussian and Poisson-Gaussian processes are the two essential statistical processes that are used for impulsive noise modelling.

4.2.2. Bernoulli-Gaussian Model

Within a Bernoulli-Gaussian model, the random time of occurrence of the impulses is modelled by the binary Bernoulli process, $b(m)$, and the amplitude of the impulses is modelled by a Gaussian process. The Bernoulli process, $b(m)$, is referred to as a binary-valued process which has a value of 1 and must have a probability value of α managing a probability of $1 - \alpha$. The probability mass function (pmf) of a Bernoulli process is the following (Andreadou & Pavildou, 2009).

$$P_B[b(m)] = \begin{cases} \alpha, & \text{for } b(m) = 1 \\ 1 - \alpha, & \text{for } b(m) = 0 \end{cases} \quad (4.7)$$

Gaussian probability density function (pdf) with a zero mean for the random amplitude of impulsive noise is given as (4.8), where the σ_n is the variance of the noise amplitude.

$$PN[n(m)] = \frac{1}{\sqrt{2\pi\sigma_n}} \exp\left\{-\frac{n^2(m)}{2\sigma_n^2}\right\} \quad (4.8)$$

And the pdf of impulsive noise, $n_i(m)$ as part of the Bernoulli-Gaussian model is given as (4.9), where $\delta[n_i(m)]$ is the Kronecker delta function. In the function $PN_{BG}[n_i(m)]$ there is a mixture of a discrete probability mass function $\delta[n_i(m)]$ as well as a continuous pdf $PN[n_i(m)]$.

$$PN_{BG}[n_i(m)] = (1 - \alpha)\delta[n_i(m)] + \alpha PN[n_i(m)] \quad (4.9)$$

4.2.3. Poisson-Gaussian Model

The Poisson process helps modelling the probability of occurrence of an impulsive noise event within the Poisson-Gaussian model. The Gaussian process helps modelling the distribution of the random amplitude of impulsive noise. As stated in (Papoulis & Pillai, 2002), the Poisson process is a random event-counting process. The formula for the Poisson model, the probability of occurrence of k impulsive noise events in a time interval T and rate function λ given by (Papoulis & Pillai, 2002):

$$P(k, T) = \frac{(\lambda T)^k}{k!} e^{-\lambda T} \quad (4.10)$$

λ consists of:

- $\text{Pr}(\text{one impulse in a small time interval } \Delta t) = \lambda \Delta t$
- $\text{Pr}(\text{zero impulse in a small time interval } \Delta t) = 1 - \lambda \Delta t$

The assumptions stated include that only a single impulsive noise event may take place at time interval Δt . The $n_i(m)$, in a small time interval Δt and the pdf of impulsive noise in a Poisson-Gaussian model are presented by:

$$PN_{PG}[n(m)] = (1 - \lambda \Delta t)\delta[n_i(m)] + \lambda \Delta t PN[n_i(m)] \quad (4.11)$$

Where, as before, the Gaussian pdf is: $N_{PG}[n(m)]$ (Papoulis & Pillai, 2002).

4.2.4. Classification of EMI in Middleton's theory

In Middleton's theory, there are three classes of EMI extracted.

- I. Class A – This class has been originally defined in order to compare the bandwidth of noise or keep it less than the bandwidth of the receiving system. Modifications have now been made to include the noise pulses which do not even produce transients in the receiver's front end.
- II. Class B – The noise pulses are able to produce transients within the receiver as the noise bandwidth is greater than the receiving system bandwidth.
- III. Class C – This is a linear sum of Class A and B. The derivation models concise exposition has been presented by Skomal.

Optimum reception of signals in Class A and B noise has been analysed by Spaulding and Middleton. The overlap index is A_A and as per Middleton it is the impulsive index. This is referred to as the mean number of emissions per second times the mean length of an emission in seconds. An exponential distribution power is present for noise if it consists of a Gaussian distribution (Middleton, Aug 1977) & (Middleton, Aug.1979).

4.2.5. Middleton class A noise

Middleton Class A noise model is useful in describing the statistical characteristics of impulsive noise in the PLC environments. Background and impulsive noises are both integrated within the model. Keeping a PDF, with an overall noise as a sequence of independent and identically distributed (i.i.d.) complex random variables, the Middleton Class A model has been presented in (Anon., 2006) (Andreadou & Pavildou, 2009) (Pighi, et al., 2006).

Accuracy and basic requirements of the real impulsive noise modelling has been fulfilled by Middleton's class-A impulsive noise model. Hence, this model has been widely used for PLC systems analysis (Umehara, et al., 2004) & (Ardakani, et al., 2005). This research study work is also based upon Middleton's class-A to model impulsive noise and design communications systems over power lines. Impulsive and background noise have been represented by the Poisson-Gaussian model as part of the Middleton's class-A model. According to the probability of impulsive noise, m impulsive noise events in a time interval T is given by (Ardakani, et al., 2005);

$$p = \frac{(\lambda T)^m e^{-\lambda T}}{m!} \quad (4.12)$$

The amplitudes of both background and impulsive noise are modelled by the Gaussian random process model. The impulsive index is $A = \lambda T$. Hence, Middleton's class-A impulsive noise probability density function can be presented as;

$$\sum_{m=0}^{\infty} e^{-A} \frac{A^m}{m!} \frac{1}{2\pi\sigma_m^2} \exp\left(-\frac{|n|^2}{2\sigma_m^2}\right) \quad (4.13)$$

Where, σ^2 is the total noise power for both Gaussian and impulsive.

$\Gamma = \sigma_G^2 / \sigma_I^2$, is termed as the mean power ratio of the Gaussian to impulsive noise.

Impulsiveness reduces and noise and Gaussian noise become closer when A increases. A Poisson distribution has been observed as part of the equation 4.13 of impulsive noise. With a different variance, each impulsive noise source generates a characteristic Gaussian noise.

$N_0 = 2\sigma^2$ is the one-sided power spectral density of the total white noise.

The pdf of class A impulsive noise can be written as function of A, Γ and N_0 as below (Ardakani, et al., 2005):

$$p_A(n) = \sum_{m=0}^{\infty} e^{-A} \frac{A^m}{m! \pi N_0} \frac{A(1+\Gamma)}{m+A\Gamma} \exp\left[\frac{-A(1+\Gamma)|n|^2}{(m+A\Gamma)N_0}\right] \quad (4.14)$$

In Figure.4.2. the pdf of the Middleton Class A noise is given with an impulsive index $A=0.01$.

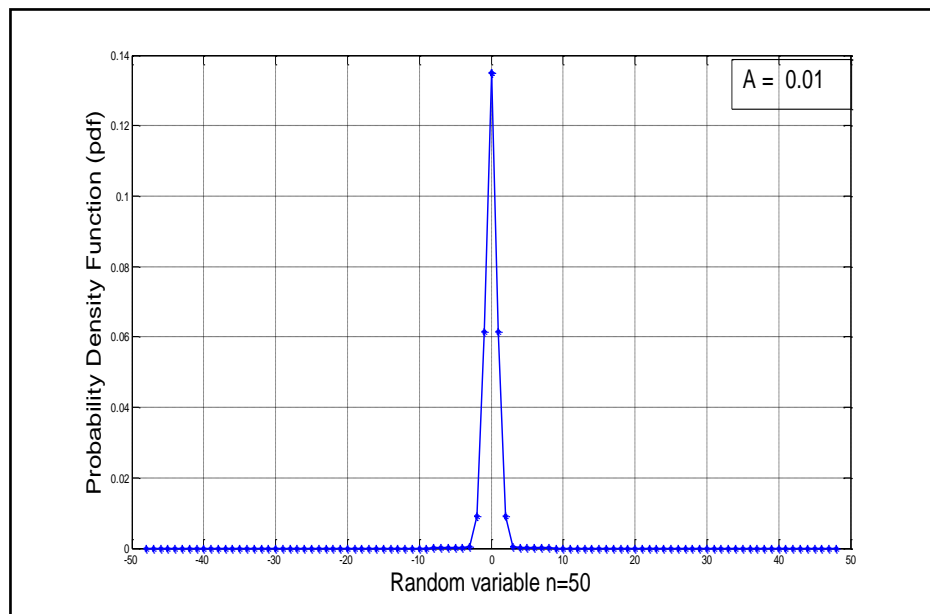

Figure.4.2. Pdf of the impulsive noise with impulsive index $A=0.01$.

The effect of variation in Middleton class A parameters A and Γ are shown in Figure.4.3. and Figure.4.4.

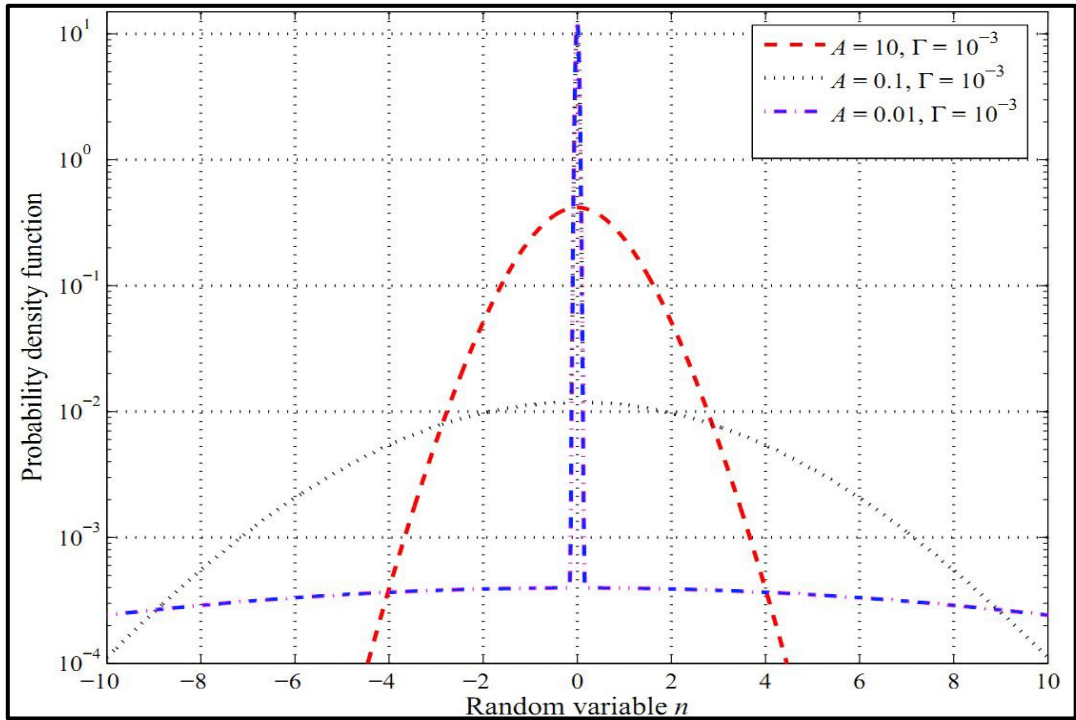

Figure.4.3. Pdf of the Middleton Class A noise with impulsive variable index A

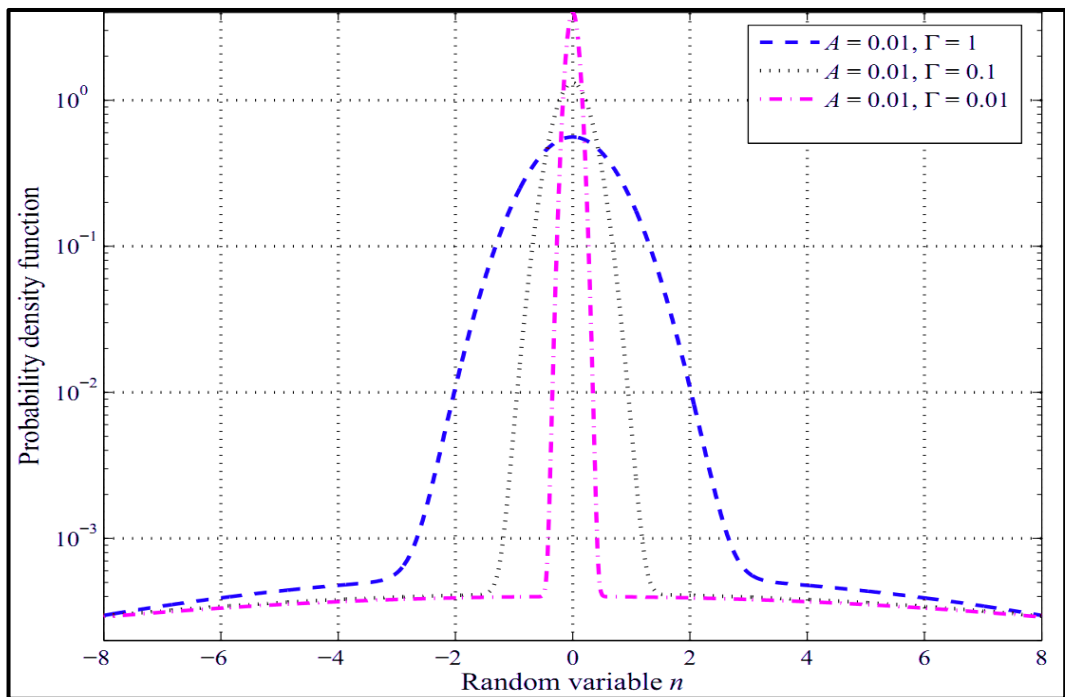

Figure.4.4. Pdf of the Middleton Class A variable Γ

4.2.6. Mitigation of the effect of impulsive noise

The characteristics of Impulsive and AWGN are different. Therefore, the same technique for mitigation of AWGN cannot be implemented to combat the effect of impulsive noise in PLC systems. To reduce the effect of impulsive noise, many of the researchers proposed to make use of:

- QAM modulation: a single carrier modulation technique with high spectrum efficiency. The effect of the QAM technique for an impulsive noise (Middleton class A) was investigated in (Proakis, 2000) & (Miyamoto, et al., 1995). The results indicate that QAM reduce the BER for the same SNR.
- OFDM: the impulsive noise effect becomes distributed across multiple spread carriers at the receiver. Hence, the effects of impulsive noise in the PLC is reduced (Dai & Poor, 2003).
- Error correcting codes: such as block and convolutional code (Haring & Vinck, p. 2003).

This research study uses the combination of all above-mentioned ways to reduce the effect of Middleton class A noise in PLC systems.

4.3. BER performance in PLC under an impulsive noise

A PLC can be modelled as in Figure.4.5. The model consists of a PLC transmitter, the PLC channel with noise and the receiver block. According to the model, the received signal $r(t)$ is given by :

$$r(t) = s(t) * h(t) + n(t) \quad (4.15)$$

where:

$s(t)$ is the signal injected into the channel by the transmitter, $h(t)$ is the impulse response of the channel and $n(t)$ is the noise in the channel.

According to (Zimmermann & Dostert, 2002) there are various models available for PLC channel such as the Zimmermann and Dostert model, Philipps model and the Anatory et al. model. The multipath model proposed by Philipps and Zimmermann is a widely used model for investigating the data transmission over power lines and is given by:

$$H(f) = \sum_{i=1}^N g_i e^{-(a_0 + a_1 f^k)^{d_i}} \cdot e^{-j2\pi f d_i / v_p} \quad (4.16)$$

where:

$H(f)$ is the frequency response of the channel, g_i is the weighting factor, d_i the length of the data transmission path, k is the exponent of the attenuation factor; d_i/v_p stands for the time delay and a_0 and a_1 are attenuation parameters.

As in PLC Frequency Shift Keying (FSK), Amplitude Shift Keying (ASK) and Phase Shift Keying (PSK) are used for low- data rate (300Kbps), for higher data rate transmission of more than 2Mbps modulations such as M-ary PSK, M-ary QAM and OFDM are used. In OFDM as the symbol duration increases for the lower rate subcarriers, the amount of dispersion in time caused by multipath delay reduces, thereby reducing the inter-symbol interference (ISI) leading to higher data rates (Bui, 2006).

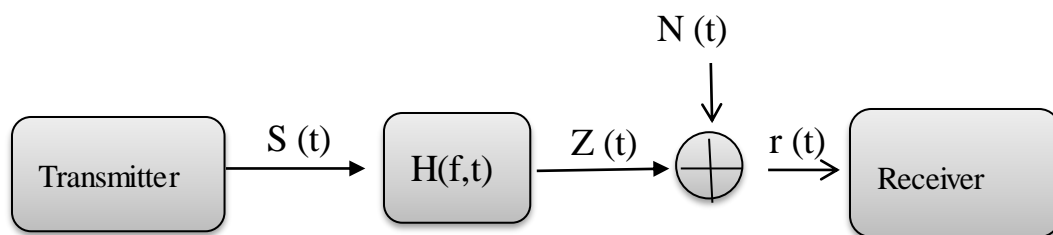

Figure.4.5. The PLC model

4.3.1. Simulation and results

Results of simulations undertaken in Matlab to quantify the BER performance of a PLC system using a higher modulation constellation of 16-QAM with Hamming code in presence of impulsive noise are given in this section. Figure.4.6. illustrates the diagram of the OFDM system used for simulation. FEC code such as the Hamming code is used to enhance the data rate. An interleaving block is used to arrange the coded bits in a way that erroneous bits will be randomly distributed over many code-words rather than only a few code-words, subsequently the data bits are sent to the QAM modulator for mapping. Next is the OFDM stage which uses pilot signals to detect the channel response. The data stream is split into 16 parallel streams (by use of serial to parallel converter) that modulate 16 subcarriers using the IFFT. The CP is inserted to reduce ISI. The multipath channel model has been used as given in (Mlynek, et al., Jul 2010). Background and impulsive noise are injected through the Channel.

The effect of background and impulsive noise on the signal amplitude is given in Figure.4.7. As observed the impulsive noise distorts the signal amplitude while propagating through the channel. For 16 QAM the effect of variation in the impulsive index A from 0.001 to 10 on the BER is shown in Figure.4.8. A high value of A corresponds to low amplitude pulses with frequent occurrences, while a low value of A corresponds to high amplitude and less frequent pulses. As A increases the BER performance improves with increasing SNR. A low value of A would correspond to a significant fault interference in the power line likely as a result of a major fault, while higher values of A would be the more regular low power interference caused due to common sources such as heating and electric motors.

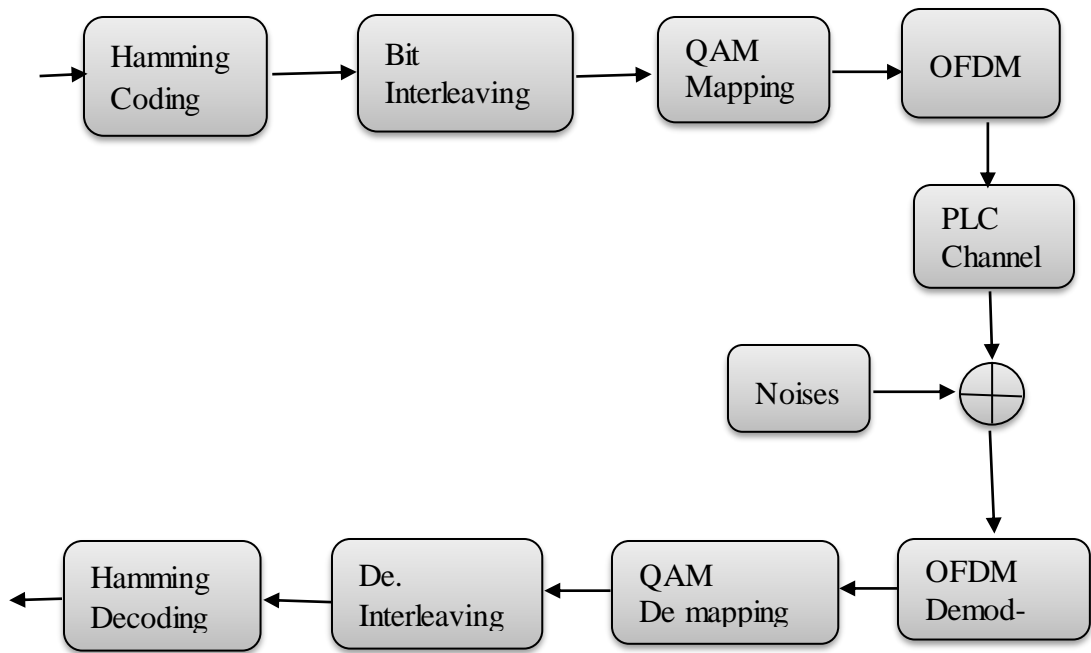

Figure.4.6. Diagram of an OFDM system consisting of a transmitter, a PLC channel and a receiver.

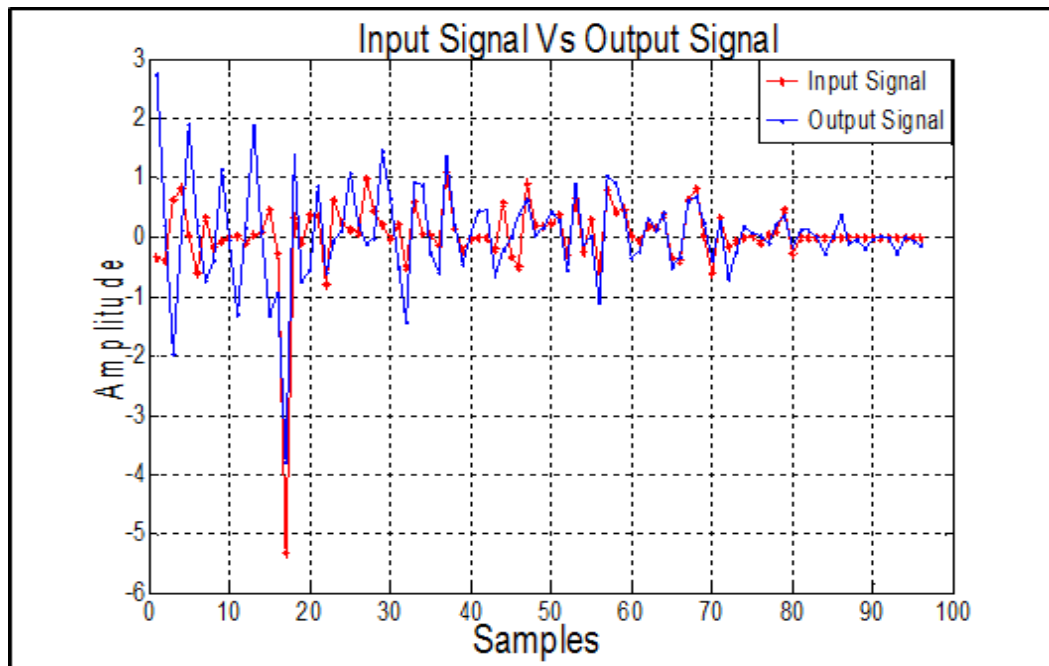

Figure.4.7. Input signal Vs output affected by AWGN and Impulsive noise

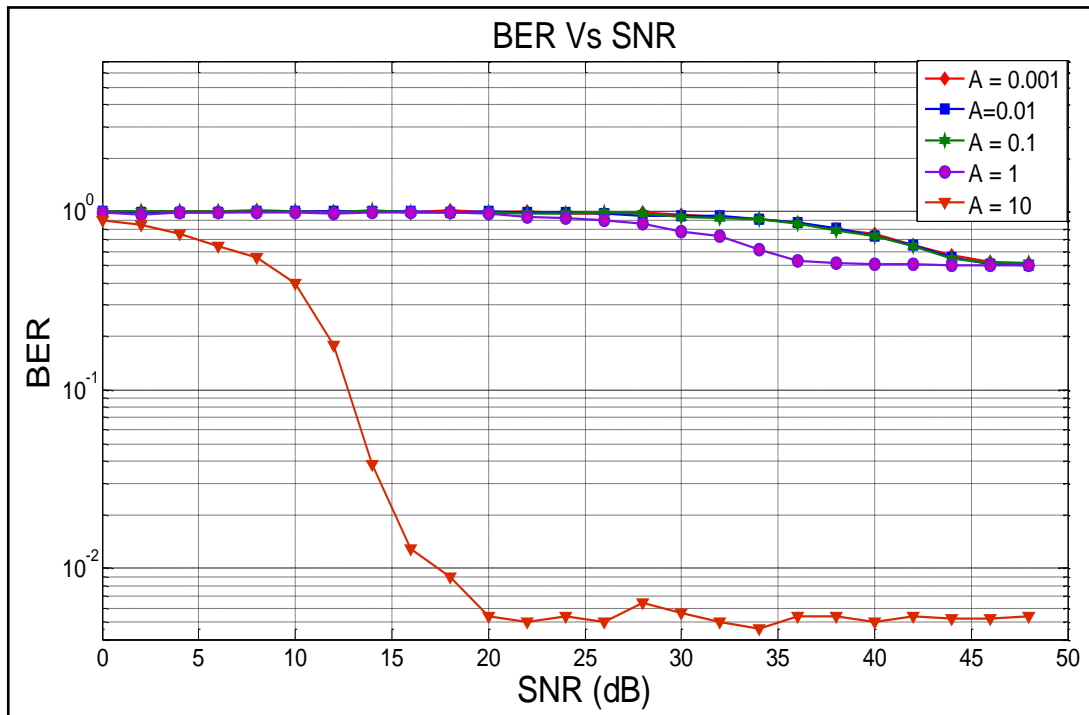

Figure.4.8. BER V.s. SNR for different value of index (A) of Middleton Class A for the PLC channel.

As it can be seen from figure.4.8. when Γ is kept constant at 10^{-3} and the impulsive index A is varied from a small value to the larger value, the characteristic distribution of impulsive noise changes, i.e. an impulsiveness reduces. In particular, when $A=0.001$ the distribution of an impulsive noise has its highest impulsive characteristic. On the other hand, at $A=10$ the distribution of impulsive noise reduces which results better BER performance for the system. Figure.4.9. shows the BER performance of the PLC through a multipath channel with background and impulsive noise. The BER performance is for $A=10$. The BER performance of the impulsive noise is worse than the background noise, even though for higher A values. The BER performance can be improved by using suitable filters. However the improvement is likely to occur for high values of A , for low A values the improvement is not likely to be the same due to a much higher level of interference

Figure.4.10. and figure.4.11. illustrate the effect of AWGN and Middleton class A noise separately on the input signal to the PLC channel.

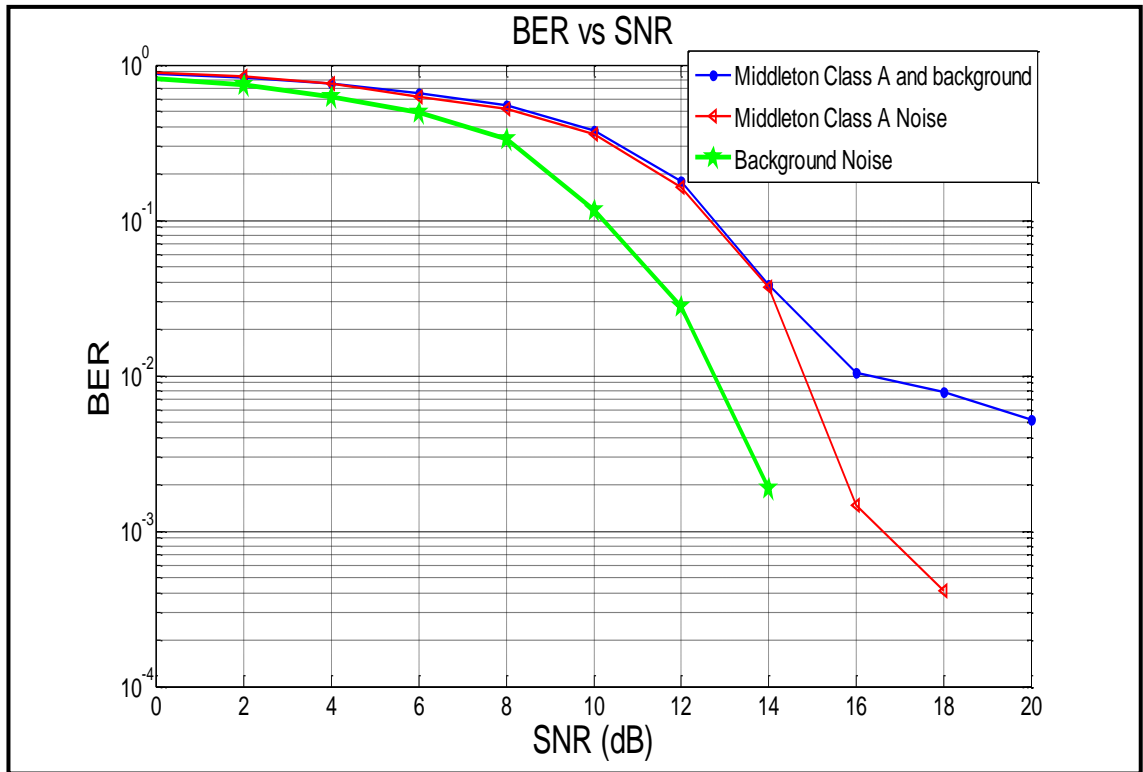

Figure.4.9. SNR Vs. BER for the multipath PLC channel

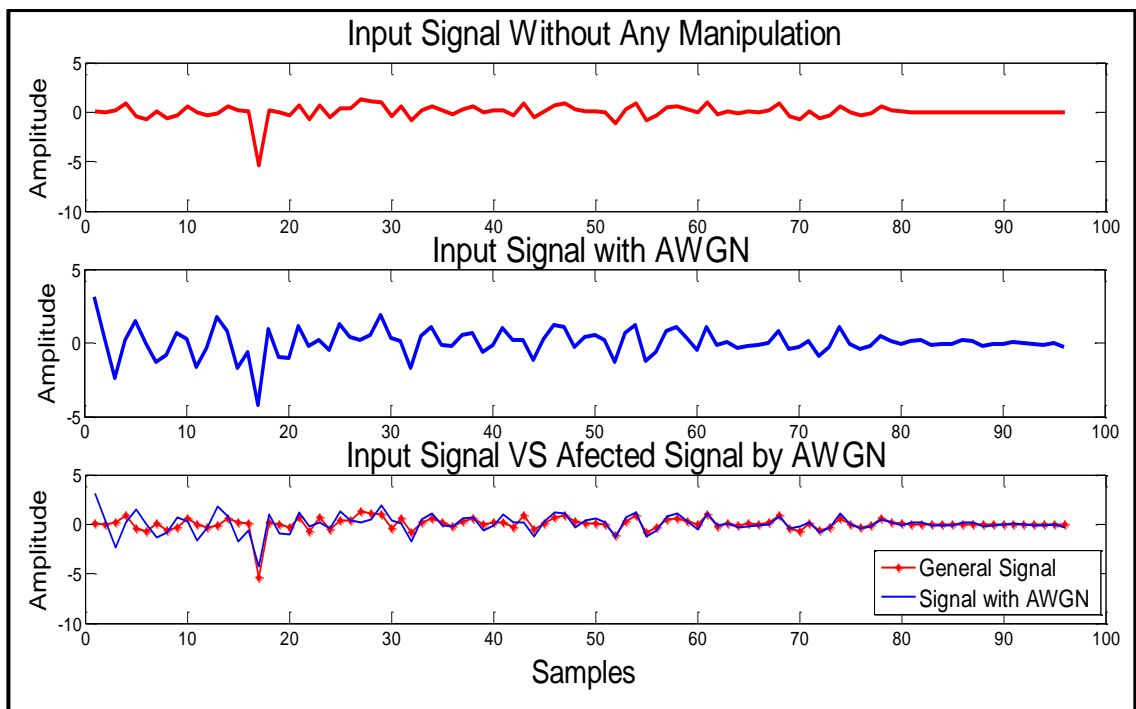

Figure.4.10. Input signal to the channel Vs output with the effect of AWGN

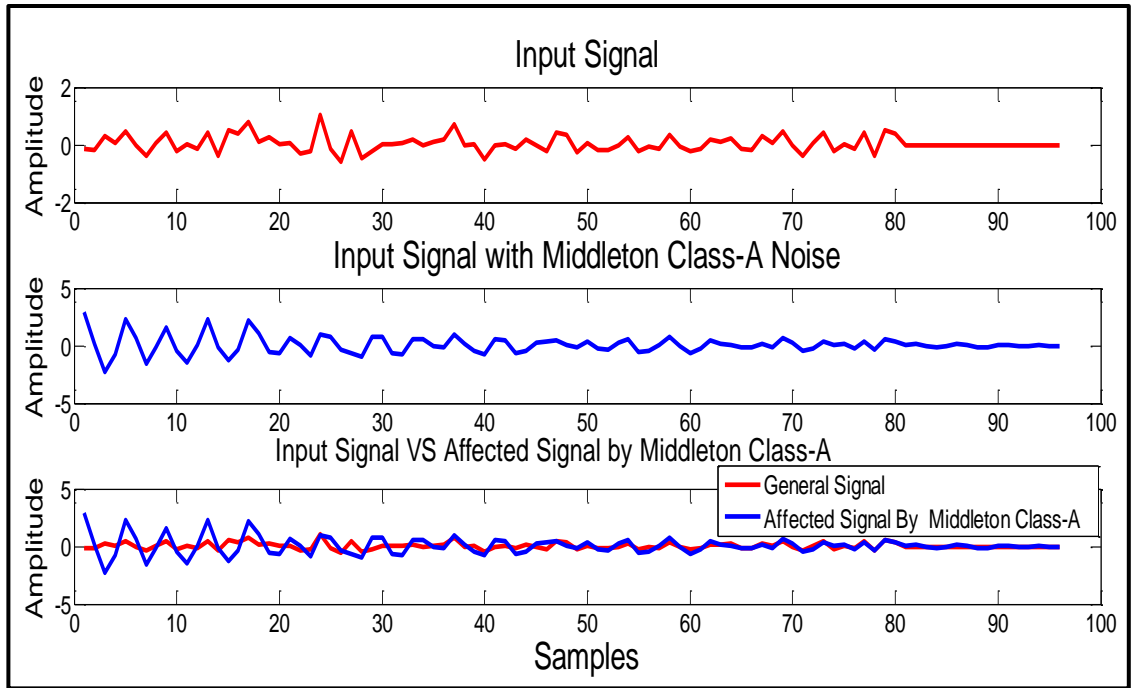

Figure.4.11. Input signal affected by Middleton Class A (Impulsive noise)

4.4. Summary

Main sources of noise in a power line are caused by the interference due to electric appliances connected to it which affect the data transfer over PLC channels. The main sources are the background and impulsive noise. In order to analyse the performance of PLC system in presence of an impulsive noise, a mathematical model for an impulsive noise is required. In this chapter various models for an impulsive noise are discussed and mathematically explained. A Middleton Class A is discussed in detail and is selected as the impulsive noise for this research study and modelled in Matlab. The BER performance of the system was investigated for a higher signal 16-QAM constellation using OFDM technique. It is observed that BER for the impulsive noise is higher than the background noise. The BER further deteriorates with increasing the level of the impulsive noise, even while being injected into the PLC channel at a lower rate. Applying methods to mitigate and reduce the effect of impulsive noise over PLC

systems for higher constellations to increase the data rates could be carried out by means of alternate FEC/ convolution codes and suitable filters would be worth investigating.

Chapter 5

Data Transfer Implemented by Trellis Coded Modulation on PLC based OFDM

5.1. Introduction

TCM is a combination of coding and modulation. The word trellis stands for the use of trellis codes. It is bandwidth efficient modulation based on the convolutional coding system by doubling the number of constellation points of the signal that results an increase in bit rate and keeping the symbol rate at the same. TCM was originally proposed for transmission over AWGN channels, but later it was further developed for applications such as in mobile, wireless and power line communications systems, where it is capable of achieving a coding gain without bandwidth expansion (Ng, et al., 2006). In (Hongchun, 2012) a comparison between TCM and Reed Solomon (RS) coding for MV electric distribution line carrier communication system showed that the TCM can have a great advantages compared to other coding methods such as Reed-Solomon (RS) in a MV power line system. Convolutional code and TCM based on OFDM for a Rician fading (Satellite) channel was considered in (Anushruti, et al., 2013). The BER performance comparison between these two illustrated that the TCMOFDM provides better performance compared to the convolutional ones. OFDM is known to cope with multipath channels and suitable for data transmission over power line (Chiang, et al., 2010). The adoption of coding and OFDM system can possibly enhance the transmission rate. A TCMOFDM, in spite of large coding delay, works the best among all the coding schemes, although

complicated in implementation. While TCM-OFDM system has the best compromise between performance and complexity (Fernando & Ragetheva, 1998).

In this section the effect of the AWGN and Middleton Class A noise on the performance of TCM OFDM and rectangular QAM TCM for PLC system is investigated.

5.2. Trellis Coded Modulation (TCM)

As it was discussed in an earlier chapter, for the purpose of error correction, an additional redundancy bits will be transmitted with a code as a consequence. This requires a wider bandwidth to keep the same data rate and the same SNR with lower BER. This is a trade-off between the bandwidth efficiency and the power efficiency. TCM which was invented by Gottfried Ungerboeck is one of existing approaches to mediate these two conflicting factors. It is a combination of modulation and coding system for more effective utilization of the bandwidth and power.

For instance a code rate $2/3$ TCM is a combination of $(N,K)=(3,2)$ convolutional coding technique and an $2^3=8$ -PSK modulation approach as it is shown in Figure.5.1 and Figure.5.2. This is a four state convolutional code. In the encoder section, the 8-PSK signal mapper creates one of the 8 PSK signals depending on 3-bits symbol $b_u = [b_1 \ b_2 \ b_3]$ which contains two uncoded message bits (b_1 and b_2) and the output bits (with an additional coded bit). Since trellis can be used as an encoding technique for such a system, for the decoding TCM coded signal, the Viterbi algorithm can be used. In order to use such technique, there are couple of things to consider (Yang, et al., 2009);

- Using a larger modulation order with the same SNR reduces the minimum distance among the code words which may also cause suffering the BER performance.
- TCM has some limitation to combat the possible degradation for BER performance which are listed below;
 - i. The convolutional coding can only allow certain paths of signal points. This causes an increase for the free distance between various signal paths in trellis.
 - ii. In decoder section, a soft decision decoding technique is normally used to find the path with minimum distance (Euclidean distance) within the trellis. This makes the trellis code design to maximize the Euclidean distance through the code words (Yang, et al., 2009).

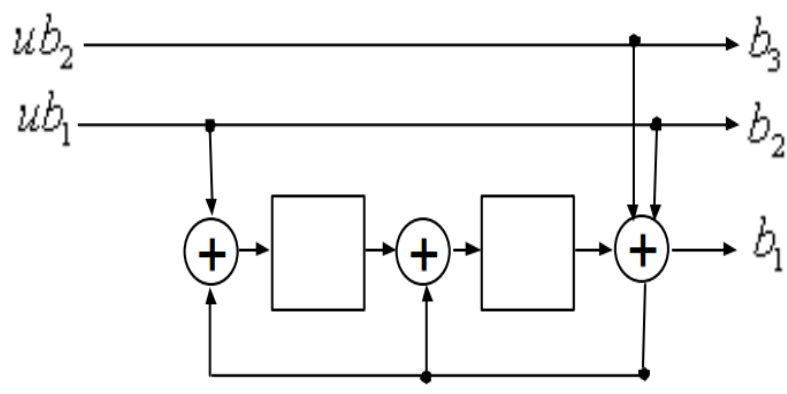

Figure.5.1. 2/3 rate convolutional encoder

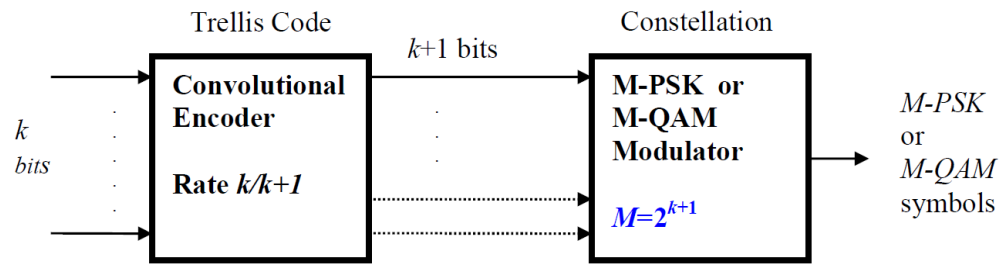

Figure.5.2.Trellis Coded Modulation (Yang, et al., 2009)

5.2.1. General information about TCM

- TCM is a bandwidth efficient modulation based on convolutional coding which conserves bandwidth by doubling the number of constellation points of the signal. This way the bit rate increases, but the symbol rate stays the same.
- Unlike a true Convolutional code, not all incoming bits are coded and only one extra bit is always added.
- Increasing the constellation size reduces Euclidean distances between the constellation points, but sequence coding offers a coding gain that overcomes the power disadvantage of going to the higher constellation.
- The decoding metric is the Euclidean distance and not the Hamming distance.
- TCM uses set-partitioning and a small number of states (Georgiadou, 2008).

5.2.2. Rectangular QAM TCM

A rectangular QAM TCM implements a TCM by convolutionally encoding the binary input signal and mapping the result to a rectangular QAM signal constellation (matlabr14b, 2014).

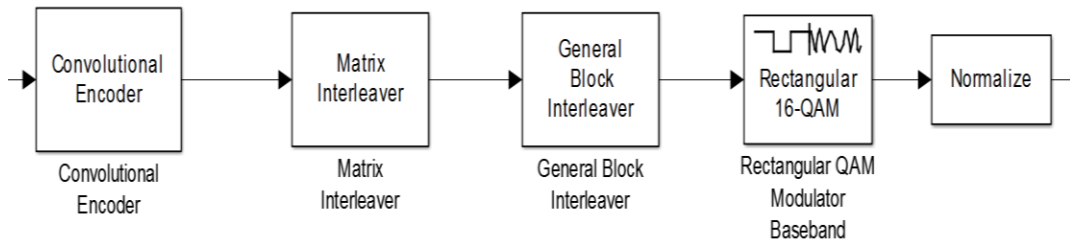

Figure.5.3. Rectangular 16-QAM TCM

In general rectangular QAM signal constellations are sup-optimal in the sense that they do not maximally space the constellation points for a given energy with the advantage of easily transmission and also demodulation.

This section investigates the performances of the TCM/Rectangular 16-QAM TCM systems for power line multipath channel under impulsive noise and AWGN. Conventionally, receivers for a TCM/rectangular 16-QAM TCM system have been designed based on Euclidean distances between signal sequences assuming their use under Gaussian, impulsive noise and multipath environments.

5.3. System model

In order to have a general view of the proposed system model being used in this section, a block diagram of the Simulink model is given in Figure.5.4. This figure shows the block diagram of the rectangular 16-QAM TCM based on OFDM for PLC system. A quick description of the individual blocks is given with the purpose of offering a better understanding.

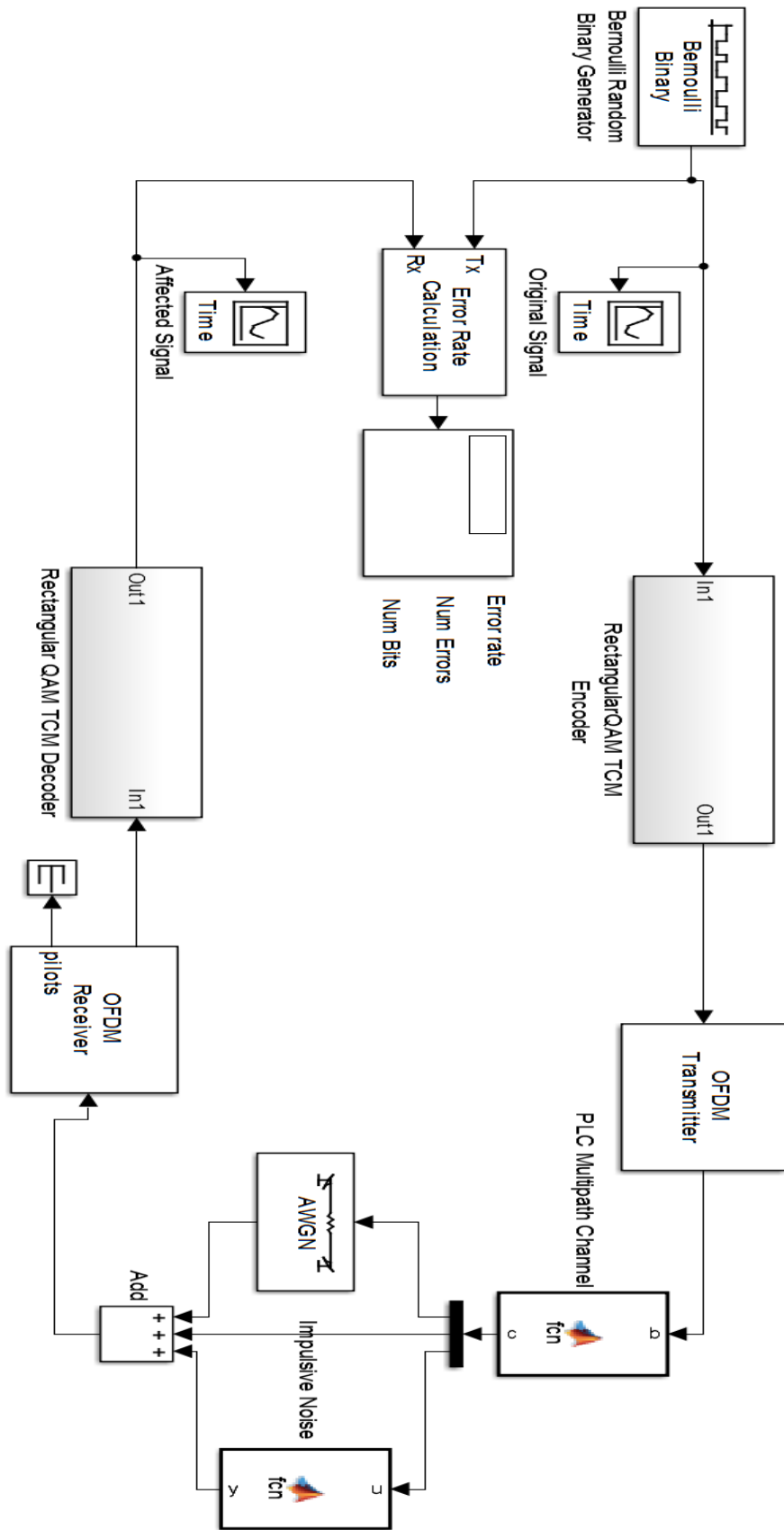

Figure.5.4. System model with rectangular 16-QAM TCM

5.3.1. Transmitter section

The Bernoulli Binary Generator block generates random binary numbers using a Bernoulli distribution. The rate of the convolutional encoder presented by k/n . This block accepts a binary-valued input signal. The output signal is a complex column vector. In a TCM / rectangular QAM TCM encoder, the added redundancy bit for error control does not increase the signal bandwidth. The mapping in transmitter encoder is done by set partitioning which increase the intra subset Euclidean distance. Each partition causes an increase in minimum distance between constellation points. Since a convolutional encoder can be presented as a state diagram with its output representing a state transition. Therefore, every state will branch out to different states depending upon the input. This fact along with the set partitioning principle is carefully used to assign symbols within same subset, which have maximum distances, to the outputs when two branches emerge or converge at a state. This selection ensures a minimum Euclidean distance between any two paths in the state trellis that emerge from a state and then re-emerge back later. As the performance of convolutional code is dominated by Euclidean distance, this careful selection of symbols and design of encoder results in improved performance.

A TCM/rectangular 16-QAM TCM as the channel coding and modulation with $\frac{3}{4}$ code rate is been used in the transmitter section. The rectangular 16 - QAM TCM encoder implements the TCM by convolutionally encoding the binary input signal and mapping the result to a QAM signal constellation. The signal constellations and mapping is done by a normalize block.

To define the encoder, the Trellis structure parameter poly2trellis (7, [171 133]) was used where 7 is a constant length of the encoder, 171 and 133 are the code generator polynomials in octal numbers.

Synchronization in OFDM systems is however needs careful considerations. Since orthogonality is maintained only when the transmitter and receiver are synchronized which thus critical to the performance of the OFDM system. Therefore, how to develop effective synchronization algorithms for satisfactory performance and less complexity is a major issue to be considered.

In the transmitter, the input serial data stream is converted into the word size needed for transmission and then shifted into a parallel format. The data is then transmitted in parallel by assigning each word to one carrier in the transmission. Then the information bits are mapped into baseband symbols. An IFFT is then used to convert this signal to the time domain, and to produce the orthogonality between subcarriers, allowing it to be transmitted.

A number of zeros can be added to the input data vector to center the spectrum. This ensures the zero data values are mapped onto frequencies close to plus and minus half the sampling rate, while the nonzero data values are mapped onto the subcarriers around 0Hz.

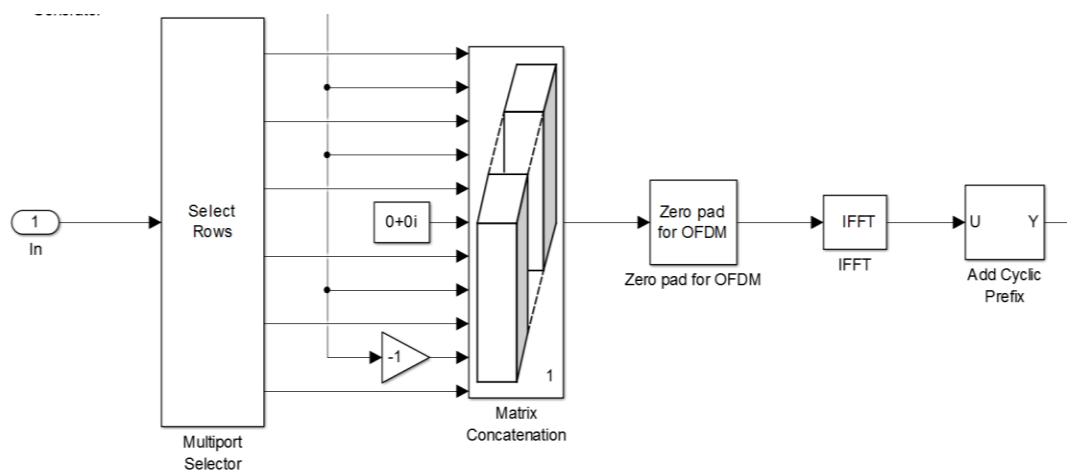

Figure.5.5. The schematic of OFDM modulation (matlabr14b, 2014)

In order to protect successive OFDM symbols from multipath a CP of length N_g is used which is a copy of the last part of the samples of a OFDM transmit block appended to the front before transmission as depicted in Figure.5.6.

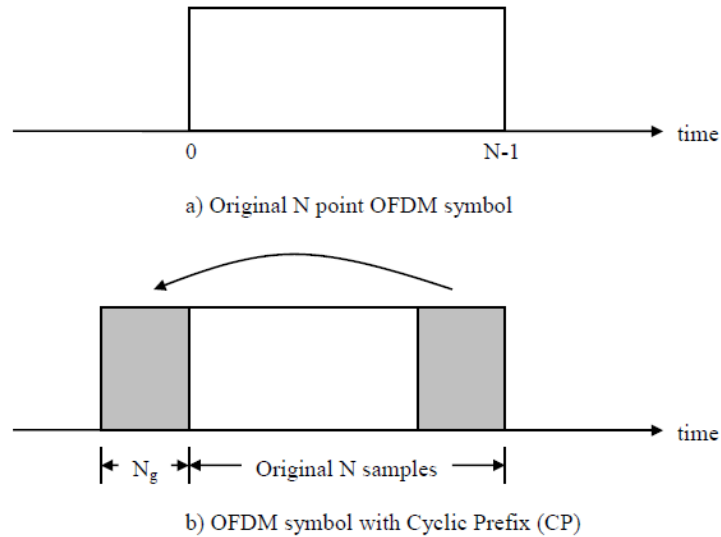

Figure.5.6. OFDM symbol; a) without cyclic prefix, and b) with cyclic prefix

The transmitted signal is therefore $N+N_g$ samples. Provided that the length of the CP is chosen so that it is longer than the longest expected delay path successive OFDM symbols will be free of ISI. In other word the main purpose of using CP is to create guard intervals by copying the last part of OFDM symbol and inserting as a first part of OFDM symbol. The benefit of CP insertion is maintained as long as the span of the time dispersion does not exceed the duration of the CP. The drawback of using CP is OFDM system is increased overhead.

The OFDM baseband signal of IFFT output using N subcarrier is:

$$x_n(j) = \frac{1}{N} \sum_{K=0}^{N-1} X_k(j) e^{j2\pi kn} \quad (5.1)$$

Where $X_k(j)$ is the modulated complex data of the K-th subcarriers in the j-th OFDM symbol, and n is the sample time. The transmitted OFDM symbol with CP is :

$$S_n(j) = \sum_{n=-G}^{N-1} x_n(j) \quad (5.2)$$

Where G is the length of CP and the received n-th sample in the j-th OFDM symbol is:

$$y_n(j) = \frac{1}{N} \sum_{k=0}^{N-1} X_k(j) e^{j2\pi \frac{kn}{N}} H_k \quad (5.3)$$

Where H_k is the channel frequency response at the k-th subcarrier.

The parameters set in proposed system with $T=0.05 \mu s$ are listed in Table.5.1.

Coding rate	$\frac{3}{4}$
Modulation technique	OFDM
Data interleaving	matrix Interleaver and General Block Interleaver
FEC Coding	TCM / Rectangular 16-QAM TCM
IFFT/FFT	16
Signal Constellations and mapping	Normalize
Puncturing rate	$\frac{4}{6}$
Sampling rate $f_s=1/T$	20 MHz
CP duration T_{CP}	$16 * T$, $0.8 \mu s$
Channel	Multipath + AWGN

Table.5.1. Proposed system parameter set

5.3.2. Channel model

The channel model for this section is same as the one being used in previous section. It is a multipath channel model which was designed in Matlab and added as a function to the AWGN channel.

5.3.3. Noise model

The noise scenario in the PLC is complicated due to the presence of different sources of disturbance. There are two possible approaches for modelling noise in PLC; a physical model which requires an individual circuit for each source, and statistical physical model which provides universal models for natural and human made sources. In order to combat against unacceptable performance, the true characteristics of the noise in power line must to be taken into account. For this reason a Middleton Class A noise and AWGN which are from statistical physical models are chosen for this part of the research work investigation. A Middleton class A noise added to the multipath channel as a written function in Matlab program as well as an AWGN model in Simulink has been used in this section. These two models have been used to develop optimum detection algorithms for a wide range of communications problems. The two main advantages of using the Middleton Class A in the system are (Middleton, 1979):

- It can be expressed as canonical form, therefore noise from various interference scenarios can be presented by the same model but with a different set of coefficients.
- It is analytically tractable and computationally manageable.

5.2.4. Receiver Section

The structure of the OFDM demodulator system is shown in Figure.5.7. The receiver generates side information about the channel conditions for use in OFDM demodulator and TCM/rectangular 16-QAM TCM decoder. The OFDM demodulator is implemented by an inverse process of OFDM modulator. In the design of the demodulator OFDM at the receiver section, at least three main synchronization issues must be considered carefully. The first is the frame

timing synchronization, which can be resolved by a careful design of the preamble. The second is the frequency synchronization, which can be estimated and then compensated by exploiting the information contained in the received preambles, pilot subcarriers, and CP. Thirdly the symbol timing and sample clock synchronization, which can be estimated by using pilot subcarriers and CP.

The purpose of using CP in OFDM modulator is to add some circular periodicity to the transmitted signal. This can be broken and removed in demodulator section by use of removing the CP block in Matlab/Simulink. The FFT used in OFDM demodulator is the inverse process of IFFT in OFDM modulator and converts the signal in the frequency domain to detect and compensate for the frequency components associated with the transmission path. The signal then is set to the frame based samples to the value of the sampling mode of the output signal parameter.

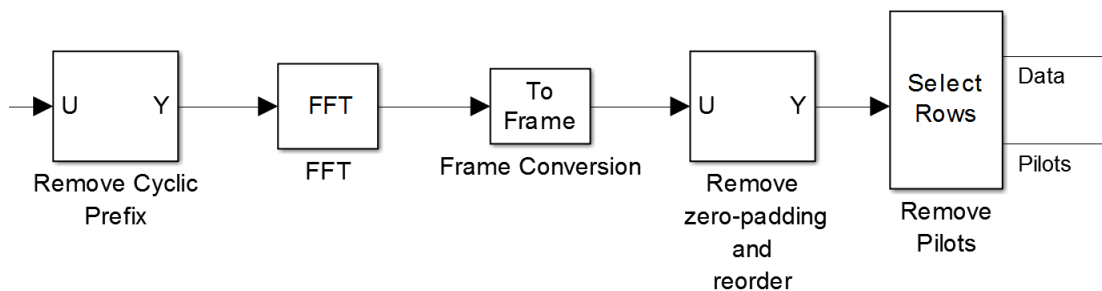

Figure.5.7. The schematic of OFDM demodulator

5.2.5. Simulation Results

Although trellis codes produce improvements in the SNR, they do not perform well with multipath power line channel and Middleton class A noise. Performance of TCM with/without impulsive noise and rectangular 16-QAM

TCM in Matlab/Simulink has been studied. Simulation results indicate that although the TCM gives better performance in BER compared to the uncoded QAM, in presence of Middleton class A noise and multipath channel, but the BER still is so much for such a channel coding system. However as it is shown in Figure.5.9. the TCM has better BER performance in presence of only AWGN. Therefore the rectangular 16-QAM TCM has been used to enhance the results. A 16- QAM achieves a great distance between adjacent points in the I-Q plane by distributing the points more evenly. The constellation points for rectangular 16-QAM TCM is spaced evenly inside the square. In this way the constellation points are more distinct which results reducing data errors. The advantage of using higher order of M array QAM is that it is able to carry more bits of data per symbol which then results an increase in the data rate. The drawback of applying higher order of M array QAM is that it can be less resilient to noise and interference. A puncturing code and interleaver applied at the encoder, and the decoder uses a Viterbi algorithm to enhance the data transmission in the rectangular 16-QAM TCM.

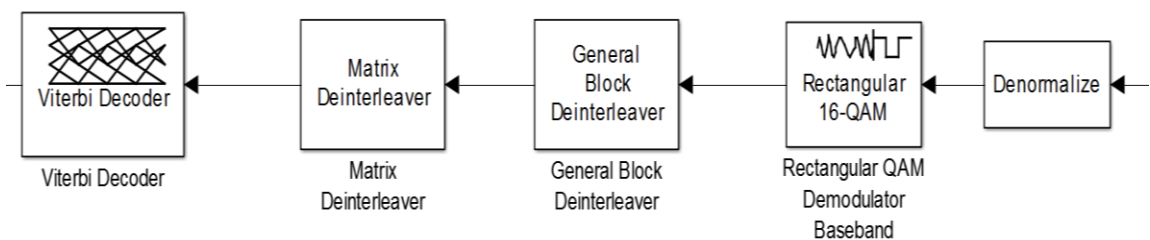

Figure.5.8. Decoding of rectangular 16-QAM TCM

Interleaving breaks the correlation and enables the decoder to eliminate or reduce local fading throughout the band and over the whole depth of the time interleaving. The punctured codes are a common way of achieving higher code

rates, i.e. larger ratios of k to n . Punctured codes are created by first encoding data using a rate $1/n$ encoder and then deleting some of the channel symbols at the output of the encoder. The process of deleting some of the channel output symbols is called puncturing. The Punctured code being used is $[1\ 1\ 1\ 0\ 0\ 1]$, where a one indicates that a channel symbol is to be transmitted, and a zero indicates that a channel symbol is to be deleted. As it is shown in Figure.5.10. applying Viterbi algorithm and puncturing code results a significant reduction in BER of rectangular 16-QAM TCM. Due to this reduction, the rectangular 16-QAM in presence of AWGN and Middleton class A noise also has better error rate in comparison with TCM in presence of even only an AWGN.

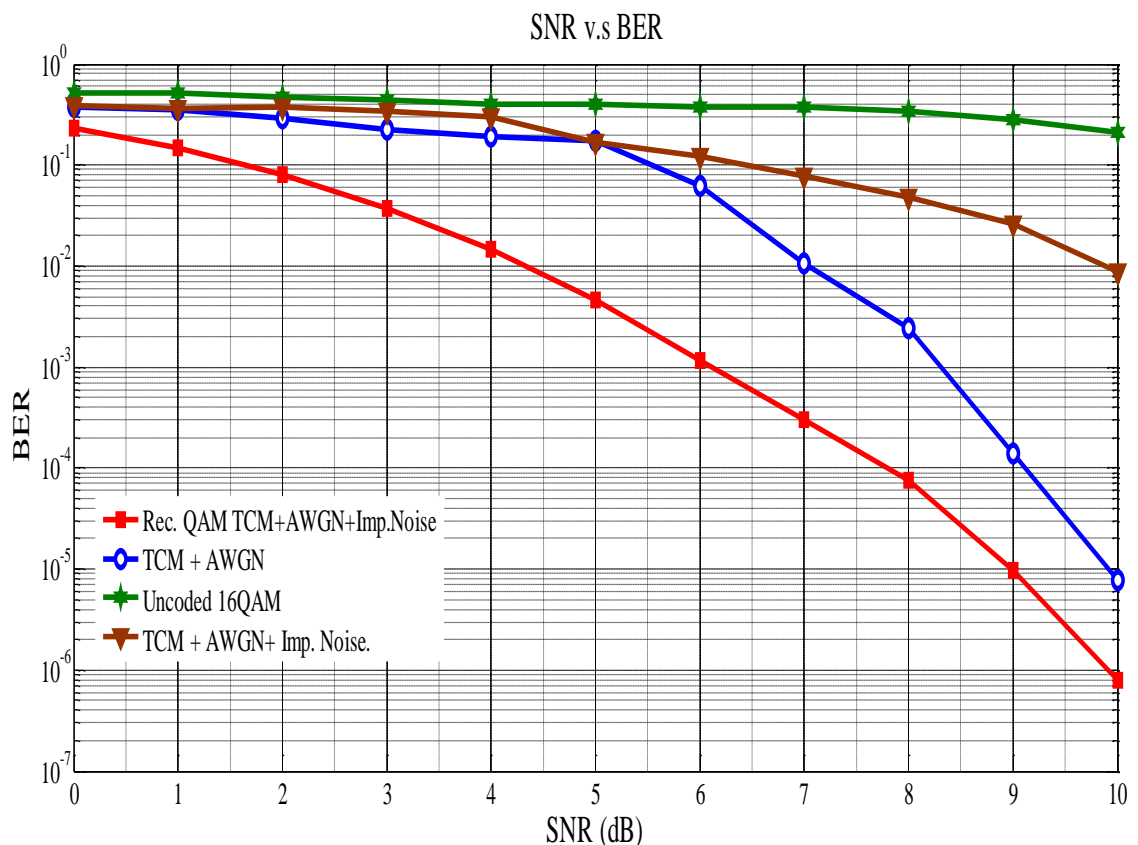

Figure.5.9. Simulation results for TCM and rectangular 16-QAM TCM

5.4. Summary

The efficiency of the TCM technique against Gaussian noise has been well known. However, its performance for impulse noises which degrade the quality communications remain unknown. Simulink/Matlab simulations are carried out to verify the efficiency of the TCM/rectangular 16-QAM TCM schemes against the impulse noise, power line multipath channel and AWGN. A TCM / rectangular 16-QAM TCM coding combined with OFDM modulation is used to combat the bursty of the Middleton Class A noise under a PLC Multipath channel model. The obtained results indicate that although TCM improves the SNR slightly better than uncoded ones, but it does not achieve a good BER performance in the presence of an impulsive noise. However, using the rectangular 16-QAM TCM based on OFDM with a puncturing technique and the Viterbi decoder in receiver section can enhance the transmission quality significantly.

Chapter 6

Validation, discussions and Critical Analysis

6.1. Introduction

This research study has followed an analytical research design in order to model and simulate the PLC system by use of the given channel characteristics. As an alternative to experimental design, the results are validated by critical comparison to existing case studies and literatures. The modelling assisted the assessment of the system in a logical way that can be used in the experimentation. There are some advantages of using model system which are listed below:

- Helps to assist in the development and analysing a large system.
- It can improve reliability and saving money by making the project easier to understand before releasing it in the real world.
- Helps to design an experimental setup that is suitable for the application.
- Minimises the risk of experiment failure.
- It can be verified with the actual measurements later.

6.2. Interpretation and reporting

Interpretation of data has been carried out to discuss the outcome of the simulation results from PLC models. After interpretations, the outcome of the research study has been reported at various conferences and in journal proceedings.

The evaluation of this research study is performed by use of Matlab/Simulink simulation and case studies. Scenarios developed for this thesis can be easily compared to the results obtained for countries like Tanzania; and simulation in different software program such as ATP EMTP, would further validate the results of this research work. Decisions taken and routes taken during the modelling of the PLC can be monitored, analysed and reviewed by use of the mentioned technique. The evaluation stage is followed by a critical discussion section which in details, outlines the arguments and analysis of the work through a comparative study. Based on the form of the simulation results in this thesis, the validation strategy is split into three parts, each of which can be validated individually with different case studies. Every sub validation is carried out by use of general arguments from the simulation results and observations gained in the different case studies.

6.3. Critical analysis and validations

The results of this research study derived from modelling of the multipath channel, a Middleton Class A noise as an impulsive noise, OFDM modulation with various channel coding such as the Hamming, TCM and the rectangular 16-QAM TCM in Matlab/Simulink. Some investigations have been done regarding the variation in time/frequency responses due to the influence of load impedance, branches and line length. But none of them mention the exact contribution of each parameter to the stochastic behavior of channel responses.

In this section, some of the existing research works are critically reviewed and discussed.

One such example is the test and simulation done in Tanzania for a power line in which it is observed that as the line length increases, there are rapid changes in the signal phase response as shown in Figure.6.1. This could perhaps limit the available transmission bandwidth of the low voltage channel (Anatory & Theethayi, 2010).

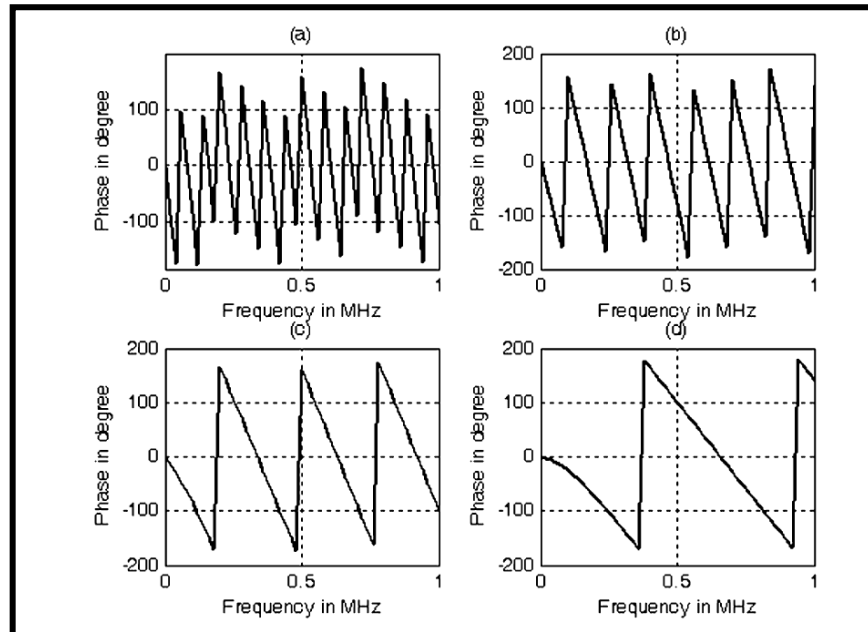

Figure.6.1. Phase response for a typical power line link one branch (a) 4 Km, (b) 2 Km, (c) 1 Km, (d) 500m. Ref (Anatory & Theethayi, 2010)

It is also observed that frequency response has also changed as the branches length is varied. As it is shown in Figure.6.2. as the length of branched line increases the number of notches increases and as the branched length becomes shorter the received signal becomes more distorted.

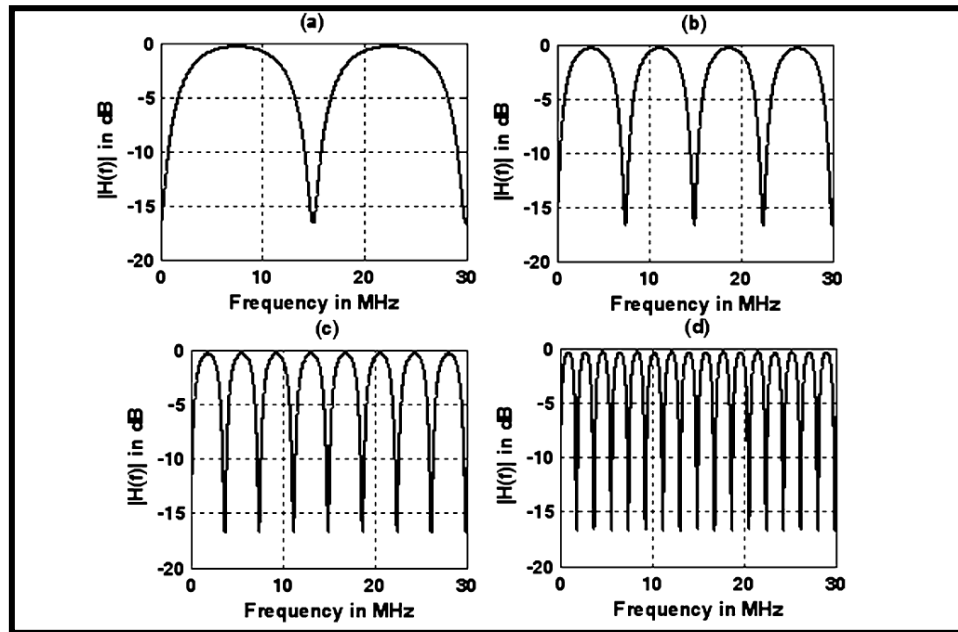

Figure.6.2. Simulation results for a typical channel of 4 Km with one branch of length (a) 10, (b) 20, (c) 40 and (d) 80m.

In (Hassina, et al., 2005), the influence of load impedance, branch line length, effect of number of branches and direct line length of the transmitter to the receiver point on the performance of a PLC system was investigated. The main focus for this research was the signal degradations caused by the time variant connections of electrical devices on the power line grids. It has been found that the channel condition changes when customers switch on/off their electrical devices (loads) to the power line socket. In (Anatory, et al., 2007) based on the effects of different loadings at different branches with the ATP EMTP programing software was shown the significant attenuations and distortions introduced in the signal when the number of branches increases. (Anatory & Theethayi, 2010) performed number of experimental studies on channel characterization of broadband communication channels and their results impeccably correspond to the simulations and analytical study in the first part of this research work. The experimental work performed by these researchers also

focuses on PLC in which they have assessed the performance of the channels with the service quality of up to 100 MHz. Based on Tanzanian power line characteristic they identified that by increasing the number of interconnections at one point the signal from the source to a point increases, which has implications to electromagnetic interference. The effect of varying topologies on the performance of a PLC network was also investigated using different number of branches, line lengths and load impedances from a transmitter to a receiver by using ATP-EMTP software. From the simulation, it is observed that with the increase in number of branches, the BER increases. Repeaters are used in order to keep BER within limits when the signal power cannot be increased beyond certain limits. The increase in the number of branches results in an increase in BER.

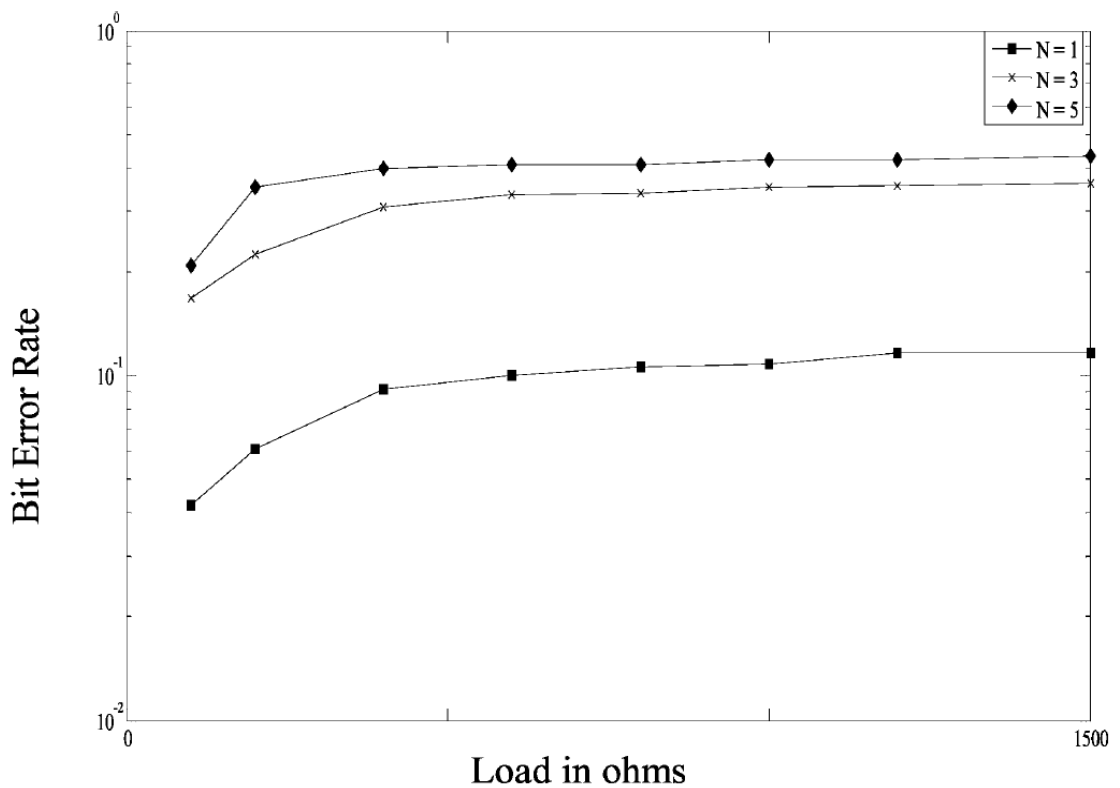

Figure.6.3. Performance of the PLC system with different load impedances (Zahida, 2010)

The simulation results for channel characteristics of a power line for this PhD research study work, has given a fine match with the studies performed by above mentioned researchers and also the experimental related work in this field. However the simulation results cannot be exactly the same due to the differences in channel characteristics for each country and even region.

Matlab/Simulink simulation results of the first part of this research study clearly illustrate that;

- There is no multi-path fading as the channel response is a linear function of the frequency in the direct line channel from the transmitter to the receiver. Therefore, even a single carrier modulation technique can be used to recover the transmitted signal.
- An increase in number of branches results and an increase in signal distortion of the channel. In other word there would be an increase in BER of the transmission. In order to keep the BER within specified limits, either the distance between the used repeaters can be reduced or the signal power of the system can be increased (which causes an increase in the SNR)
- For the case of varying the line length with a single branch, the positions of the notches and peaks are changing. Therefore multi carrier modulation technique would be better modulation option for data transmission. In theory the BER of the system will also increase and there is possibility of signal lost at some points. Therefore repeaters are required at some specified distances. These repeaters amplifies the received transmitted signal and injects them to the network again.

- The power of the incoming signal determines the distance that can be covered by the PLC systems which in turn decides the data rates. The power also introduces considerable interferences and various types of noise in the PLC. The combined effect is that when the PLC systems cover longer distances the data rates are very low because of the increased interferences and noises. If both longer distance and higher data rates are required then this can be achieved by using a repeater technique. Although, the use of repeaters helps in attaining both greater distance and higher data rates simultaneously but it increases the cost. This problem, however, can be countered by positioning the network stations properly. The ideal case is that the stations are placed in such a way that the PLC network gets divided into small network segments thus; reducing the need of greater power and interferences/noise, therefore each station can serve the purpose of repeater as well. But this arrangement increases the complexity of the station and requires intense and complex management for assigning time or frequency slot allocations in the network. With the increase in the number of repeaters the delay in the signal is increased because of the time being taken by the repeaters. Therefore, it is recommended that the number of repeaters in any network is limited.
- There is a small change in the frequency response as the branch load changes from 40Ω to 80Ω . In other hand an increase in the load results and increase in the BER. However, by increasing the number of branches in the network the effect of load reduces in the network. This is because an increase in the number of branches results reduction in the

impedance of the system due to the ability of having the large number of impedance in parallel. Therefore, the effect of loads remains hidden in such low impedance system.

An AWGN does not give a complete description of the noise on a power line channel. The channel suffers from different forms of narrow-band interferences and impulse noise. To study impulsive noise a few of the models available were presented in the research work. The impulsive noise can significantly degrade the performance of PLC systems. Hence, to provide the impairments in the hostile channel, channel coding becomes important. Not many research has been made to study the effect of Middleton class A noise on PLC systems. The main research works have been discussed below;

In (Rahman & Majumder, 2012) performance improvement of a PLC is investigated on the basis that noise is considered to be a non-white Gaussian random process. The impulsive noise causes bit errors in the signal and is considered to be time variant. It occurs for a short duration and randomly with a high Power Spectral Density (PSD). To improve the effects of fading and the impulsive noise on the signal, the OFDM modulation technique was used. According to the simulation results, noise depended on time and frequency which caused deterioration in system BER and the degradation was significant at higher bandwidth and bit rates.

In (Wang, et al., 2012) the performance of the OFDM system for PLC systems was analysed and the results were compared with a single carrier system. It was demonstrated that under AWGN, the performance of the system remains the same with or without OFDM because OFDM demodulation performs the FFT, which is actually a linear process. The additive Gaussian noise is

Gaussian distributed, even after it goes through the linear FFT process. An analysis was performed to study the influence of impulsive noise on the OFDM system and it was found that the OFDM performs better than single carrier modulation for the PLC in the presence of an impulsive noise as it is shown in Figure.6.4.

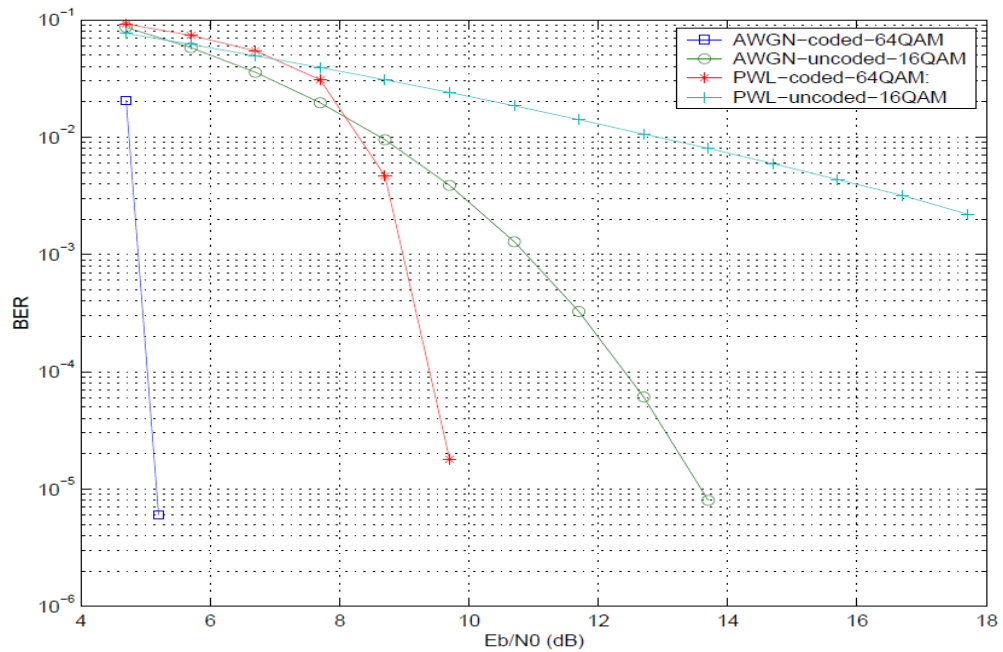

Figure.6.4. BER of OFDM/64-QAM over power line and AWGN channel.

In (Al-Mawali, et al., 2012) an impulsive noise as one of the major challenges which can cause serious problems in OFDM-based PLC system is investigated. Techniques such as error correction code, time domain and time/frequency domain are discussed to mitigate the effect of impulsive noise and enhance the performance of PLC systems. The results showed that applying error correction code had a performance that presents almost an outright elimination of impulsive noise in the PLC.

Different types of noise interferences of electrical appliances degrade the performance of PLC systems. Based on this, in the second part of this study

work, research was made on the BER performance of a 16-QAM constellation with OFDM in presence of Middleton Class A over a multipath PLC channel. The Middleton's model enables to study the noise characteristics of various devices with an advantage of the model to be constructed as an equivalent to real world noise source. To minimize the effect of the Middleton Class A noise in PLC systems, Hamming code and OFDM are combined for this part of the research study. The performance of OFDM is better than single carrier in the presence of an impulsive noise due to the fact that OFDM scatter the effect of impulsive noise over multiple symbols as a result of DFT operation. The cyclic prefix reduces the effect of multipath by dividing the transmitted bit stream into many different sub streams which are then sent over different sub channels. The number of sub streams is chosen in such way that each sub channel has a bandwidth less than the channel's coherence bandwidth so that the sub channels experience relative flat fading. The data rate on each sub channel is less than the total data rate and the bandwidth of the associated sub channel is also lesser than the total system bandwidth. Hence the ISI on each sub channel is of a small value. The sub channel saves a lot of bandwidth and simultaneously achieves high data rates so it is not necessarily contiguous. The results show that the Middleton class A noise has a higher BER in comparison with AWGN. The simulation results of the combination of the hamming code and OFDM on the PLC multipath channel show that, the data rate performance improves in the presence of the Middleton class A noise.

Normally modulation and coding are two different and independent functions. Coding is a digital function and modulation is an analogue function. However in TCM they are combined together. TCM was originally proposed for

transmission over AWGN channels, but later it was further developed for other digital communication's applications. It is capable of achieving a coding gain without bandwidth expansion. However not adequate study has been made to investigate the performance of TCM based on OFDM on PLC system in presence of an Impulsive noise. TCM OFDM has been investigated in some other digital communication system such as wireless and mobile communication (Yanxia & Lei, 2006). The results from investigation in (Miyamoto, et al., 1992) on the optimum detection and the proposed model for the TCM under impulsive noise environment show that TCM achieves better performance than the uncoded. PLC channel based on TTCM has been designed, analysed and implemented in various modulation techniques such as QAM, OFDM etc. (Anushruti, et al., 2013). In (Liew & Ng, 2003) TTCM was used due to its advantages such as higher frequency using rate, easier tolerance of phase ambiguities, better trade-off between complexity and coding gain. TTCM is a more recent proposed bandwidth efficient transmission method, with a similar structure to the family of binary turbo codes and also distinguishing itself by employing TCM schemes as component codes. Both the TCM and TTCM schemes employed set partitioning based signal labelling, in order to increase the minimum Euclidean distance between the encoded information bits (Liew & Ng, 2003). A convolutional and TCM are considered with OFDM for a Rician fading (Satellite) in (Anushruti, et al., 2013). The BER performance comparison between these two showed that the TCM OFDM provides better performance compared to the convolutional ones as it is illustrated in Figure.6.5.

In this research work study a TCM and rectangular 16-QAM TCM as a convolutional code over multipath channel in presence of AWGN and Middleton

class A noise is been designed in Matab/ Simulink and studied. Although the TCM based on OFDM for PLC multipath channel in presence of impulsive noise does not provide well performance in BER, but the simulation results proved under carefully reconstruction and chosen algorithms for decoder section, a rectangular 16-QAM TCM based on OFDM system can enhance the performance over PLC channels. The simulation results show that at higher values of SNR is advantageous to use rectangular 16-QAM TCM, because the constellation points in 16-QAM results an increase in data rate and reduction in error rate.

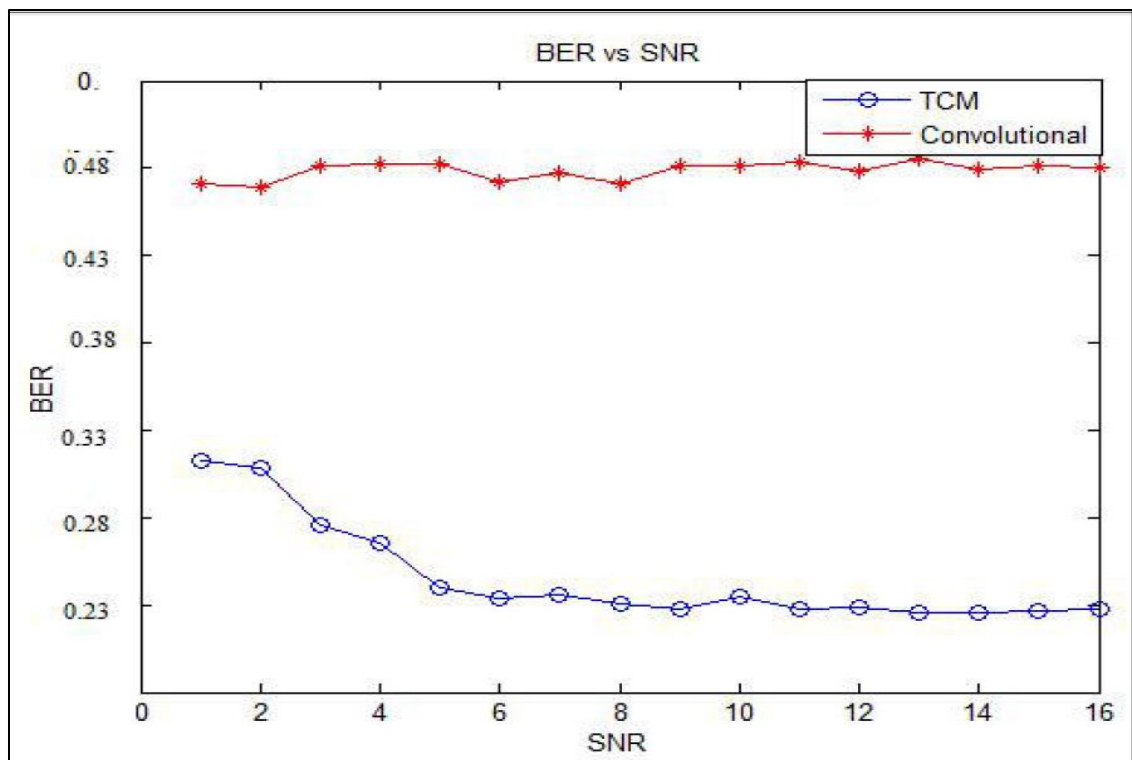

Figure.6.5. BER v.s SNR comparison of TCM and Convolutional (Anushruti, et al., 2013)

Chapter 7

Conclusions and further research

The research provides a detailed overview of the progress and advancements in PLC and the relevant parameters of the field. Data transmission has not yet been possible in electric power grids because of a number of issues. However, with advancements in technology, it has started to become a possibility. Power lines are considered as a competition to xDSL telecommunication lines and modems to provide internet access to the consumers whether residential or commercial, LV and MV of the. The main advantage of PLC is that it does not require any new wiring for the implementation of the system, therefore it is cost effective.

In areas where DSL or cable modems cannot provide data transmission to customers, and the fibre optic installation is expensive, the PLC system can be an alternative to be used to provide internet to customers. PLC system can also be used for narrowband applications such as an automation system and smart metering. The development of PLC systems requires an adequate knowledge of the power line channel characteristics. An investigation on PLC multipath channel model in presence of an impulsive and background noise indicated the suitability of MCM technique such as an OFDM over the power line channels. OFDM provides high robustness against impulsive noise and minimizes the effects of multipath by spreading it over multiple subcarriers. Therefore each of the transmitted communication symbols are only affected by a fraction of the impulsive noise. It is also observed that the BER for an impulsive noise is higher than the background noise. Various channel coding techniques such as a

hamming code, TCM and rectangular QAM TCM to enhance the data transmission are applied to the multipath PLC model. It is been observed that although TCM improves BER performance for AWGN, but they do not perform well with an impulsive noise. The proposed rectangular QAM TCM model based on OFDM with the help of puncturing technique and reconstructed Viterbi decoder provides better BER rate. This is because the space between the constellation points are not maximised with the advantage of easily transmission and also demodulation.

7.1. Summary of the results

According to the literature review of the related work, there is an increase interest in the PLC technology as an alternative for data transmission over power lines. However, ML / LV power line channels were only designed for the transmission and distribution of energy signal at 50/60 Hz, therefore they present a harsh environment for the other type of data transmission. Attenuation due to the line loss, impedance mismatch because of branches and loads, and also the dynamics of the system effect the data transmission through a PLC and change the topology of the system frequently.

In chapter two the PLC system and several parameters that affect the data communication as well as some history and background of this system was studied. It was illustrated that the quality of the power line channel varies in time, depending on the length of the channel and various numbers of loads connected to it. From this observation, it was obvious that in order to improve the power transmission system and mitigate against the time varying adverse properties of the channel, more advance communication approach is required.

In chapter three the effect of the varying number of branches, load impedances and the line lengths, between the transmitter and the receiver, on the performance of the PLC system has been studied. The channel frequency response for the LV European power distribution systems was investigated in this chapter too. The frequency response indicates a multi-path transmission which is as expected due to various branches present in the transmission path. Multi-carrier transmission is therefore suitable scheme for data transmission over such a system. The simulations generated for a power line channel indicates that as the line length increases, there are rapid changes in the signal phase response. This could perhaps cause unpredictable packet loss during the transmission. Therefore, retransmission is necessary in order to guarantee the service integrity. Although using repeaters can increase the cost, they are necessary to achieve higher data rates in longer distances. The effect of loads on the multipath PLC channel model was also studied. The results illustrated that there no much change in the BER due to linear continuous variation of load, particularly in systems containing a large number of branches. From the simulation results it was also observed that an increase in the number of branches results in an increase in BER.

Chapter four has begun with an introduction to an impulsive noise and different types of this noise. A Middleton class A was chosen as the closest type of real world noise introduced in the PLC system. The effect of variation in this type of noise parameters was investigated. The second part of the chapter investigated the new proposed model of combination of 16-QAM, Hamming code and OFDM for PLC multipath channel. It was illustrated that BER for the Middleton class A noise is higher than in the AWGN. The BER further deteriorates on increasing

the level of the Middleton Class A noise, even while being injected into the PLC channel at a lower rate. The results also illustrated that although applying hamming code combined with an OFDM modulation improves the performance of data transmission over power lines, it also results in increasing the complexity of the system. The results of the Investigation introduced in this chapter provide techniques to mitigate and reduce the effect of Middleton Class A noise over the PLC channel.

In chapter five, a proposed model based on TCM/rectangular 16-QAM TCM and OFDM under Middleton class A for the multipath PLC channel was investigated. One of the great advantages of OFDM is to convert a wideband frequency selective fading channel into a series of narrowband and frequency non-selective fading sub-channels by using parallel and multicarrier transmission. Although coding OFDM subcarriers sequentially by using TCM produce improvements in the SNR, they do not perform well with Middleton class A noise. The simulation results show that a rectangular 16-QAM TCM based on OFDM provides better BER rate in comparison with the general TCM. The advantage of applying higher order of M array QAM is to increase the number of transmission bits per symbol which results in an increase in the data rate. The drawback would be less resilient to noise and interference which needs further investigation. Interleaving is very important in channel coding as they are providing diversity in the time domain. Interleaving breaks the correlation and enables the decoder to eliminate or reduce local fading. Use of puncturing technique reduces the redundancy of the sequence to transmit by removing some of the channel coded bits at the risk of deteriorating the BER

performance, therefore the code rate increases in comparison with no puncturing technique.

7.2. Suggestion for further Works

The future research for this PhD thesis can be extended on following areas:

- (1) Investigate on effect of more than one branch at the same or different node, with the different lengths and terminated loads on the frequency response of the PLC channel.
- (2) A detailed analysis on the effect of impulsive noise (Middleton Class A) and AWGN on the OFDM system has been carried out in this research study. Further analysis of some other types of noise and mixed noise situations can possibly be made in the future.
- (3) Applying a combined turbo code with TCM in the PLC system could also be pursued as a research study. Presently, the TTCM encoder is constructed as a concatenation of the TCM inner code and simple parity check outer code by some researchers in the field. This encoder can be constructed into further complex encoding scheme to provide higher spectral efficiency and robust error correction ability.
- (4) Investigation on applying higher M-Array QAM for rectangular QAM TCM on the PLC system.
- (5) Utilisation of various types of filters to mitigate the effect of noise and enhance the data transmission in the PLC system.

References

- Adebisi, B., Giovaneli, C. L., Honary, B. & Mowlavi, M., 2007. Power Line Communications and its Applications. *ISPLC*, pp. 385-389.
- Agrawal, D. G., Paliwal, R. K. & Subramaniam, P., 2011. Effect of Turbo Coding on OFDM Transmission to Improve BER. *International Journal of Computer Technology and Electronics Engineering (IJCTEE)*, 2(1), pp. 94-102.
- Al Mawali, K. S., 2011. *Techniques for Broadband Power Line Communications: Impulsive Noise Mitigation and Adaptive Modulation*, Melbourne, Victoria: School of Electrical and Computer Engineering College of Science, Engineering and Health College of Science RMIT University.
- Amirshahi, P. & Kavehrad, M., 2007. *Broadband Access Over Medium and Low Voltage Power Lines and use of White Light Emitting Diodes for indoor Communications*. Pennsylvania, The Pennsylvania State University .
- Amirshahi, P. & Navidpour, S. M., 2006. Performance analysis of Uncoded and coded OFDM broadband transmission over low voltage power line channels with impulsive noise. *IEEE Trans. Power Delivery*, 21(4), pp. 1927-1934.
- Anatory, J. & Theethayi, N., 2010. *Broadband Power-line Communication Systems Theory & Applications*. s.l.:WIT Press.
- Anatory, J., Theethayi, N., Kissaka, M. M. & Mvungi, N. .., 2008. *Broadband PowerLine Communications: Performance Analysis*, s.l.: World Academy of Science, Engineering and Technology.
- Anatory, J., Theethayi, N. & Thottappillil, R., 2008. An Experimental Validation for Broadband Power-Line Communication (BPLC) Model. *IEEE TRANSACTIONS ON POWER DELIVERY*, pp. 1380-1383.
- Anatory, J., Thottappillil, R., Theethayi, N. & Kissaka, M. M., 2007. *THE EFFECTS OF INTERCONNECTIONS AND BRANCHED NETWORK IN THE POWER LINE COMMUNICATION*. Dar as Salam, IEEE, pp. 180-187.
- Andreadou, N. & Pavildou, F. N., 2009. PLC Channel: Impulsive Noise Modelling and Its Performance Evaluation Under Different Array Coding Schemes. *IEEE Trns. Commun*, 24(2), pp. 585-595.

Andreadou, N. & Pavlidou, N. F.-., January 2010. Modeling the Noise on the OFDM Power-Line Communications System. *IEEE TRANSACTIONS ON POWER DELIVERY*, 25(1), pp. 150-158.

Anon., 28 October 2010. Performance of double binary turbo coding for high speed PLC systems. *Consumer Electronics, IEEE Transactions on* , 56(3), pp. 1211-1217.

Anon., April, 2003. A discrete multitone transceiver at the heart of the physical layer of an in-home power line communication local-area networks. *IEEE Commun.Mag*, Volume 41, pp. 48-53.

Anon., Dec. 2003. Bit Interleaved coded modulation with iterative decoding. *IEEE Commun.Letters*, Volume 7, pp. 593-595.

Anon., Oct.2006. Performance analysis of uncoded and coded OFDM broadband transmission over low voltage power line channels with impulsive noise. *IEEE Trans.Power Delivery*, 21(4), pp. 1927-1934.

Anon., Sep.1977. Optimum Reception in an Impulsive Interference Environment-Parti:Coherent Detection. *IEEE Trans.Commun.*, 25(9), pp. 910-923.

Anushruti, J., Vyas, V. & Karthikeyan, A., 2013. Comparison of Convolutional and trellis Coded OFDM for Satellite channels. *Journal of Advanced Research in Electrical and Electronics Engineering*, 1(1).

Ardakani, M., Kschischang, F. R. & Wei, Y., 2005. *Low-density parity-check coding for impulse noise correction on power-line channels*. s.l., IEEE (International Symposium on Power Line Communications and Its Applications).

Armstrong, J. & Suraweera, H. A., Sep.2004. *Impulse noise mitigation for OFDM using decision directed noise estimation*. s.l., IEEE The 8th Int'l Symp.Spread Spectrum Techniques and Applications.

Aydin, N., 2007. *www.capital.edu*. [Online]

Available at:

http://www.capital.edu/uploadedFiles/Capital/Academics/Schools_and_Departments/Natural_Sciences,_Nursing_and_Health/Computational_Studies/Educational_Materials/Mathematics/An%20Introduction%20to%20Coding%20Theory%20via%20Hamming%20Codes.pdf

[Accessed 14 March 2014].

Bahatti, S. A. et al., Aug 2009. *Performance Analysis of a Power Line Communication System Over a Non-white Additive Gaussian Noise Channel and Performance Improvement Using Diversity Reception*. Glasgow, European Signal Processing, EUSIPCO.

Banwell, T. C. & Galli, S., 2001. *A new approach to the modelling of the Transfer function of the power line channel*. Malmö, Sweden, 5T International Symposium on Power-Line Communications and its Applications (ISPLC).

Berrou, C., Glavieux, A. & Thitimajshima, P., 2003. *Near Shannon Limit error correcting coding and decoding: Turbo codes*. Geneva, Switzerland, IEEE International Conference on Communications.

Bert, L. D., Caldera, P., Schwingshacki, D. & Tonello, A. M., 2011. *On Noise Modeling for Power Line Communication*. Udine, Italy, ISPLC, IEEE International Symposium on Power Line Communications and its Applications.

Biglieri, E. & Toino, P., 2003. Coding and modulation for a horrible channel. *Communication Magazine*, 41(5), pp. 92-98.

Brown, P. A., 1998. *Some Key Factors Influencing Data Transmission Rates in the Power Line Environment when Utilising Carrier Frequencies above 1 MHz*. Tokyo, Japan, International Symposium on Power-Line Communications and its applications.

Bui, Q., 2006. *Coded Modulation Techniques With Bit Interleaving and Iterative Processing for Impulsive Noise Channels*, Saskatchewan: University of Saskatchewan.

Cacciaguerra, F., 2003. [Online]
Available at: <http://en.kioskea.net/contents/cpl/cpl-intro.php3>
[Accessed June 2011].

Carcelle, X., 2006. *Power Line Communications in Practice*. London, Artech house.

Chandna, V. K. & Zahida, M., 2010. Effect of Varying Topologies on the Performance of Broadband over power line. *IEEE*.

Chariag, D., Guezgouz, Y., Raingeaud, J. & Lebunetel, C., 2011. *Channel Modeling and Periodic Impulsive Noise Analysis in Indoor Power Line*. s.l., s.n.

Chiang, P. H. et al., 2010. *NTU Institutional Repository*. [Online]
Available at:

<http://ntur.lib.ntu.edu.tw/bitstream/246246/2006092712274308574/1/0000000000000002.pdf>

[Accessed 5 09 2014].

Cimini, L., 1985. Analysis and simulation of a digital mobile channel using orthogonal frequency. *IEEE Transaction Communications*, Volume COM-33(7), pp. 665-675.

Consumer Focus UK GOV, 2013. *Smart meters – what are they and how can I find out more?*. [Online]

Available at: <http://www.consumerfocus.org.uk/get-advice/energy/smart-meters-what-are-they-and-how-can-i-find-out-more/benefits-and-disadvantages-of-smart-meters> [Accessed 29 Aug 2013].

Cowley, A., payne & Dawkins, M., 2002. *COFDM Tuner with Impulsive Noise Reduction*. Bulletin, European patent plication EP1180851.

Dai, H. & Poor, H. V., 2003. Advanced signal processing for power line communications. *IEEE Commun.Magazine*, 41(5), pp. 100-107.

Del Re, E., Fantacci, R., Morosi, S. & Seravalle, R., 2001. *Comparison of CDMA and OFDM systems for Broadband Downstream Communications on Low Voltage Power grid*. Malm o Sweden, 5th Internation Symposium on Power Line Communications and its Applications (ISPLC2001).

Dostert, K., 1997. *Telecommunications over the Power Distribution Grid; Possibilities and Limitations*. Essen, Germany, International Symposium on Power Line Communicationas and its Applications.

Dostert, K., 1998. *RF-Models of the Electrical Power Distribution Grid*. Tokyo, Japan, International Symposium on Power Line Communications and its Applications.

Dostert, K., 2001. *Power Line Communications*. s.l., Prentice Hall,NJ.

Fernandes, A. D. L. & Dave, P., 2011. *Power Line Communication in Energy Markets*, San Jose US: CYPRESS.

Fernando, W. & Ragetheva, R., 1998. *Performance of Coded OFDM with Higher Modulation Schemes*. s.l., ICCT.

Ferreira, C. H., Lampe, I., Newbury, J. & Swart, G. T., 2006. *Power Line communication:Theory and Applications for narrowband and Broadband Communications over power lines*. s.l.:John Wiley & sons.

Fink, D. & Jeung, R. J., 2008. *connectivity solutions based on Power Line Communication to rural and remote areas*, Korea: Information and Communication University.

G.Lazaropoulos, 2012. Broadband Transmission Characteristics of overhead High-Voltage Power Line Communication Channels. *Progress In Electromagnetics Research B*, Volume 36, pp. 373-398.

Gellings, C. W. & George, K., 2004. *Broadband Over Powerline 2004:Technology and Prospects*, Pali Alto, CA USA: Electric Power Research Institute (EPRI).

Georgiadou, D., 2008. <http://www.telecom.tuc.gr/>. [Online]
Available at:
http://www.telecom.tuc.gr/Greek/Liavas/Seminars/coding_theory/Docs/3_Trellis_Coded_Modulation.pdf
[Accessed Mid February 2014].

Gotz, M., Rapp, M. & Dostert, K., 2004. Power Line channel Characteristics and their effect on communication system design. *IEEE Communication magazine*, 42(4), pp. 78-86.

Haring, J. & Vinck, A. J., May.2003. *Iterative decoding of codes over complex numbers for impulsive noise channels*. s.l., IEEE.

Hassan, F. S., 2007. The Performance of OFDM with Blanking Nonlinearity in Impulsive and Gaussian Noise. *Journal of Engineering and Development*, 11(1).

Hassina, C., Zeddani, A. & Machmoum, M., 2005. *Broadband Power line communications: Analysis of some factors influencing the transformer function*. Boppard, German, IEEE.

Haykin, S., 2001. *Communication Systems*. 4th ed. New York: John Wiley & Sons Ltd.

Hongchun, Y., 2012. *Mid-Voltage electric distribution line carrier communication technology based on TCM*. s.l., IEEE 14th Int.Conf on Digital Object Identifier.ICCT.

Hosseinpournajarkolaei, A., Lota, J. & Hosney, W., 2012. *design of Broadband Power Line Communication system for UK power Line System*. London, University of East London.

Hrasnica, H., Hadine, A. & Lehnert, R., 2004. *broadband power line communication network design*. Chichester, West Sussex, Uk: John Wiley & Sons, Ltd.

Hrasnica, H., Haidine, A. & Lehnert, R., 2004. *Broadband PowerLine Communication Networks*. southern Gate, Chichester : John Wiley and sons,ltd.

Hrasnica, H., Haidine, A. & Lehnert, R., 2004. *Broadband Powerline communication networks*. The Atrium, Southern Gate, Chichester,: John Wiley and sons,ltd.

Johannesson, R. & Zigangirov, K. S., 1999. *Fundamentals of Convolutional Coding*. s.l., IEEE Press.

Käsper, E., 2005. *ekasper[at]tcs.hut.f.* [Online]

Available at: <http://www.mif.vu.lt/~skersys/vsd/turbo/kasper-turbo.pdf>

[Accessed 15 December 2013].

Katsis, P. L., Papadopoulos, G. D. & Pavlidou, F. N., 2007. *Comparison of Coded Orthogonal Frequency Division Multiplexing and Multicarrier Code Division Multiple Access Systems for Power Line Communications*, Thessaloniki, Greece: University of Thessaloniki.

Khalife, S. A. M., 2011. *Techniques for Broadband Power Line Communications:Impulsive Noise Mitigation and Adaptive Modulation*, Melbourne: RMIT University.

Langton, C., 2004. *Intutive Guid to Principles of Communications*.

[Online]

Available at: www.complextoreal.com [Accessed 12 October 2014].

Liew, L. & Ng, S. N., 2003. *Hanzo. Space-time block coded and IQ-interleaved TCM,TTCM, BICM AND BICM-ID assisted OFDM*. s.l., IEEE 58th. International Conference on Digital Object identifier.

Ma, H. Y., So, L. P., Gunawan, E. & Guan, L. Y., 2004. *Analysis of Impulsive Noise and Multipath Efects on Broadband Power Line Communcations*. s.l., Int.Conf.Power System Technology-POWERCON.

Maneerung, A., Sittichivapak, S. & Hongesombut, K., 2011. *Application of Power Line Communication with OFDM to Smart Grid System*. Shanghai, China, Eighth International Conference on Fuzzy Systems and Knowledge Discovery (FSKD).

matlabr14b, 2014. *Mathwork*. [Online]

Available at:

<http://uk.mathworks.com/help/comm/ref/rectangularqamtcencoder.html>

[Accessed 2 May 2014].

Ma, Y. H., So, P. L. & Gunawan, E., April 2005. *Performance analysis of OFDM systems for broadband power line communications under impulsive noise and multipath effects*. s.l., IEEE Transactions on Power Delivery.

Meng, H., Guan, Y. & Chen, S., April 2005. Modeling and Analysis of Noise Effects on Broadband Power Line Communications. *IEEE TRANSACTIONS ON POWER DELIVERY*, 20(2), pp. 630-638.

Middleton, D., 1979. Canonical Non-Gaussian Noise Models: Their Implications for Measurement and for Prediction of Receiver Performance. *IEEE Transactions on Electromagnetic Compatibility*, EMC-21(3).

Middleton, D., Aug 1977. Statistical-physical models of electromagnetic interference. *IEEE Trans. Electromagnetic Compat*, EMC-19(3), pp. 106-127.

Middleton, D., Aug.1979. Procedures for Determining the Parameters of the First-order canonical Models of Class A and Class B Electromagnetic Interference. *IEEE Trans. Electromagn. Compat*, EMC-21(3), pp. 190-208.

Miyamoto, S., Katayama, M. & Morinaga, N., 1992. *Optimum detection and design of TCM signals under impulsive noise environment*. s.l., IEEE.

Miyamoto, S., Katayama, M. & Morinaga, N., 1995. Performance of QAM system under Class A impulsive noise environment. *IEEE Trans. Electromagnetic Compatibility*, Volume 37, pp. 260-267.

Mlynek, P., Koutny, M. & Misurec, J., 2010. Multipath channel model of Power lines. *Electrorevue*, 1(2), pp. 48-53.

Mlynek, P., Koutny, M. & Misurec, J., Jul 2010. *OFDM model for power line communication*. Greece, CTT10.

Molisch, A. F., 2012. *Wireless Communication*. 2nd ed. s.l.:John Wiley & Sons Ltd.

Najarkolaei, A. H., Lota, J. & Hosny, W., 2012. *Dara Transfer Over Low-Voltage European power distribution networks*. London, Uk, IEEE.

Nakano, Y., Umbehara, D., Kawai, M. & Morihiro, Y., 2003. *Viterbi Decoding for Convolutional Code over Class A noise channel*. Kyoto, ISPLC,

7th International Symposium on Power Line Communication and Its Applications.

Newbury, J., 1999. *Technical Developments in Power Line Communications*. Lancaster, UK, 3rd International Symposium on Power Line Communications and its Applications.

Ng, S. X., Kliewer, J. & Hanzo, L., 2006. *On the Design of Turbo Trellis Coded Modulation Schemes Using Symbol-Based Exit Charts*. s.l., IEEE 64th, Conf. On Digital Object Identifier.

Nikfar, B. & Ham Vinck, A. J., 2012. *Space Diversity in MIMO Power Line Channels with Independent Impulsive Noise*. Beijing, ISPLC.Conference Power Line Comms. & its Appl..

Nikookar, H. & Nathoeni, D., 2002. *Performance Evaluation of OFDM Transmission over Impulsive Noise Channel*. s.l., IEEE.

Nomura, S., Shirai, M., Itami, M. & Itoh, K., April, 2001. *A Study on Controlling transmission power of carriers of OFDM signal*. Maim o Sweden, 5th International Symposium on Power Line Communications and its application (ISPLC).

Okab, M. E., 2004. *HF Data Transmission Using Orthogonal Frequency Division Multiplexing (OFDM)*, Baghdad: Al-Mustensiriya University.

Olsen, R., 2008. *Technical Consideration for Broadband Powerline (BPL) Communication.*, Wasington : Washington State University: School of EECS.

Papoulis, A. & Pillai, S. U., 2002. *Probability Random Variables and Stochastic Process*s. 4th ed ed. s.l.:MacGraw-Hill.

Pavlidou, N., Vinck, A. Y. J. & H. A. & Yazdani, J., 2003. Power line communications state of the art and future trand. *IEEE*, pp. 34-40.

Pednekar, R. M. & M, D. B., 2013. Design and Implementation of Convolution Encoder with Viterbi Decoder. *International Journal of Emerging technologies in Computational and Applied Science (IJETCAS)*, 6(1), pp. 84-89.

Pighi, R., Ferrari, G. & Raheli, R., Mar 2006. *Funamental performance limits for PLC systems impaired by impulsive noise*. Orlando, FL, EEE International Symposium on Power Line Communications and Its Applications.

Proakis, J. G., 1995. *Digital Communication*. s.l., McGraw-Hill.

Proakis, J. G., 2000. *Digital Communication*. 4th ed ed. s.l.:McGraw-Hill.

Rahman, M. M. & Majumder, S. P., 2012. *Analysis of a Power Line Communication System Over a Non-white Additive Gaussian Noise Channel and Performance Improvement Using Diversity Reception*. s.l., Network and Communication technology.

Rodrigues, M., 2002. *Modelling and Performance Assessment of OFDM Communication Systems in the Presence of Non-linearities*, London: University Collage.

Sandesh, M. Y. & Rambabu, K., 2013. Implementation of Convolution Encoder and Viterbi Decoder for Constraint Length 7 and Bit Error Rate 1/2. *International Journal of Engineering Research and Applications*, 3(6), pp. 42-46.

Schartz, M., Jan.2009. Carrier-Wave telephony over power lines:early history. *IEEE Communication Magazine*,, 47(1), pp. 14-18.

Schulz, W. & Schwarze, S., 2007. *Comparison of CDMA and OFDM for data Communications on the Medium Voltage Power Grid*. Limerick, Ireland, ISPLC 2007.

Sekhararao, c., Mohan Reddy, S. & Ravi Kumar, K., 2013. Performance of Coded OFDM in Impulsive Noise environment. *International journal of systems and Technologies*, 5(1).

Sekhararao, C., Reddy, S. S. & Ravikumar, K., 2009. Performance of coded OFDM in Impulsive Noise Environmen. *International Journal of Systeme, and Technologies*, 5(1).

Selander, L., 1998. *Load Profile and Communication Channel Characteristics of the Low Voltage Grid*. London, DistribuTech DA/DSM Europe 98.

Selander, L., 2000. *Data Transmission concept*, Lund, Sweden: Lund University.

Singh, R. & Singh, N., October 2012. TURBO CODES & ITS MANAGEMNT IN OFDM FOR WIRELESS LOCAL AREA NETWORK. *International Journal of Engineering & Science Research*, 2(10), pp. 1453-1461.

Sklar, B., 2001. *Digital Communication:Fundamental and application*. London, Prentice-Hall,2nd .

Sliskovic, M., July 2001. *Impulse noise detection algorithms for multicarrier Communication system-performance analysis*. Pula, IEEE.

SMSE, 2005. *Archived-Consulation Paper On Broadband Over Power Line (BPL) Communication Systems*, s.l.: Industry Canada .

Sutterlin, P. & Downey, W., 2005. *A Power Line Communication Tutorial -Challenges and Technologies*, CA USA: Palo Alto.

Tachikawa , M., Nari, M. & Hamamura, M., 2002. *Power Line data transmission using OFDM and DS/SS systems*. Athens, Greece, 6th International Symposium on Power Line Communications and its Applications (ISPLC2002).

Umehara, D., Yamaguchi, H. & Morihiro, Y., 2004. *Turbo Decoding over Impulsive Noise Channel*. s.l., Global Telecommunications Conference, GLOBECOM. IEEE.

Umehara, D., Yameguchi, H. & Morihiro, Y., 2004. *Turbo decoding in impulsive noise environment*. s.l., IEEE, Global Telecommunications Conference.

Ungerboeck, G., 1987. *Trellis-Coded Modulation With Redundant Signal Sets-Part I: Introduction*. s.l., IEEE.

Vaseghi, S. V., 2006. *Advanced Digital Signal Processing and Noise Reduction*. 3rd ed ed. s.l.:John Wiley and Sons,.

Walki, B. H., 1999. *Mobile Radio Networks-Networking and Protocols*. IBN 0-471-97595-8 ed. Chichester,UK: John Wiley & sons ltd.

Wang, L., Deconinck, G. & Van Lil, E., 2012. *Performance analysis of Broadband Power Line Communication under impulsive noise and crosstalk*. Brussels, Telecommunication and Microwaves. EAST-TELEMIC.

Wang, Y., 2006. *High Sppeed Turbo TCM for UWB and Power line system*, Orlando, Florida: University Central Florida.

Wang, Y. & Wei, L., 2006. *Turbo TCM Coded OFDM Systems for Non-Gaussian Channels*. Seattle, USA, ISIT.

Wilson, S., 1996. *Digital Modulation and coding*. London: Prentce-Hall.

Wook Kwon, B., 2009. *BROADBAND OVER POWER LINES (BPL): DEVELOPMENTS AND POLICY ISSUES*, s.l.: Secretary-General, DST/ICCP/CISP.

Yang, W. Y. et al., 2009. *Matlab Simulink for Digital Communications*. s.l.:Copyright © 2009 by A-Jin Publishing Co .

Yanxia, W. & Lei, W., 2006. *Turbo TCM Coded OFDM Systems for Non-Gaussian Channels*. s.l., IEEE.Int. Symp. On Digital Object Identifier.Information Theory.

Zahida, M. C. V. K., 2010. Effect of varying Topologies on The Performance of Broadband Over Power Line. *Power Delivery, IEEE Transaction on*, 25(4), pp. 2371-2375.

Zimmermann, M. & Dostert, K., 2002. A multipath model for the powerline channel. *IEEE Trans.commun.*, pp. 553-559.

Zimmermann, M. & Dostert, K., 2002. Analysis and modeling of impulsive noise in broad-band powerline communications. *IEEE Trans.On Electromagnetic compatibility*, Volume 44, pp. 249-258.

Appendices

Abstract: The performance of Power Line Communication (PLC) degrades due to the presence of different types of noise interferences generated by electrical appliances. This paper investigates the bit-error rate (BER) performance of a higher-order 16-QAM constellation with orthogonal frequency multiplexing modulation (OFDM) in presence of impulsive noise modelled as Middleton Class A over a multipath PLC. It is observed that BER for the impulsive noise is higher than the background noise. The BER further deteriorates on increasing the level of the impulsive noise, even while being injected into the PLC channel at a lower rate. Investigations would assist applying methods to mitigate and reduce the effect of impulsive noise over PLC systems for higher constellations with a view to increase the data rates.

Abstract: Due to the increasing importance of communication networking, the Power Line (PL) channel has been considered as a good candidate for the communication medium. Power Line Communications (PLC) term stands for the technologies for the data communication over the electrical power supply network. The PL channels were not designed to transmit high speed data; therefore they exhibit hostile medium for communication signal transmission. There are many factors such as noises, attenuation, distance and etc. affecting the quality of the transmission over PL channels. This paper presents PL model in the first sections of the work. Then it covers the security assessment of the PL system in the Supervisory Control and Data Acquisition (SCADA) context.

Abstract: Broadband power line (BPL) data transmission deals with transfer of data via the existing power line systems and is a fast emerging technology. The main advantage of BPL is being able to use the existing power line infrastructure, thereby reducing the cost. However, power line systems were not designed for high-speed data transmission as they consist of various branches and power line elements such as bridges, taps, transformers and capacitor banks. Therefore, the power line transmission medium not only introduces noise but is also adverse to high-speed data transfer in terms of the channel

bandwidth. In this paper a power line channel has been modelled using Matlab and the effects of variations in the direct length, branch length and branch load on the channel frequency response are investigated. Simulations indicate suitability of multi-carrier transmission over the power line channels.

Abstract: Broadband power line (BPL) communication systems are fast emerging as the cost-effective alternative to the broadband access networks. The main advantage of a BPL system is to use the existing infrastructure of power line networks resulting in savings and providing data network services to customers in areas without access to wired cable modems. Power line channels present a harsh environment for high frequency data transmission. The high frequency signal undergoes attenuation due to line loss and impedance mismatches because of branches and loads. In order to develop BPL communication systems, accurate estimation of the channel parameters such as capacity, noise susceptibility and the channel frequency response are required. In this paper the current research is reviewed, followed by outlining the challenges faced for high-speed data transfer over power lines and the way ahead for areas of future research in UK with respect to design of BPL communication systems is given.

Abstract: Broadband over power line grid called Broadband Power Line (BPL) communication that provides internet access over any ordinary power line. A laptop or any other computing device can be plugged into any power outlet (by use of BPL modem) in building to get access to high speed internet. The main advantage of use of BPL system over power line is to utilize the existing infrastructure of power line networks. This means great savings in wiring (cost-effective) and providing internet to customers in rural area where cannot receive cable modem or any other internet services. However, power-line systems are not designed for transferring data signal. In this paper different issue facing channel properties of BPL system will be discussed. There are some factors influencing transfer function of BPL system. The main focus of this study is to assess the effects of varying the branch's length. The success of this research would be a great forward step towards implementation of BPL system. The Integrated Development Environment (IDE) used in this study is MATLAB.

MATLab codes:

```
% Multi path PLC channel Code
% No.of branch: 1
% Variaion of load of the branch

clear all;
%***Define Constants//
ao=0;
a1=8*(1/(10^10));
k=1;
Z11=50;
Z12=Z11;
Z13=70;
Zd=1000000;
Vc=2.99*(10^8);
Vp=0.6*Vc;
L1=50;L2=50;L31=[10:100];
%***End
%***Wiegthing Factor

r1B=(( (Z12*Z13)/(Z12+Z13))-Z11)/(( (Z12*Z13)/(Z12+Z13))+Z11);
r3D=1*(Zd-Z11)/(Zd+Z11);
r3B=(( (Z12*Z11)/(Z12+Z11))-Z13)/(Z12*Z11)/((Z12+Z11)+Z13);
t1B=1-abs(r1B);
t3B=1-abs(r3B);
g1(1)=t1B;g1(2)=t1B*r3D*t3B;%g(i) is the i value of g array.
for x=1:length(L31);
    L3=L31(x);
d1(1)=L1+L2;d1(2)=L1+L2+2*L3;
N=2;

%N=[3 4 5 6 7 8 9 10];%Cannot have a value < 3;

for i=1:length(N);
g2(i)=t1B*r3D*(r3B*r3D)^(N(i)-2)*t3B;
d2(i)=L1+2*(N(i)-1)*L3+L2;
end;
g=[g1 g2];
d=[d1 d2];
%***End
%***Main Multipath Equation Implement
f1=0:1000000/2:30000*1000;
for n=1:length(f1);
f=f1(n);
for i=1:length(g);
S(i)=g(i)*exp(-(ao+a1*(f^k)*d(i)))*exp(-
(j*2*pi)*f*(d(i)/Vp));%Equation for f=1;
end;
H1(n)=sum(S);
H2(n)=abs(H1(n));
H3(n)=20*log10(H2(n));
end;
h=impz(H2);%find impulse response
H4(x,:)=H3;

end;
figure(2);
```



```

surf(H4);
hold on;
%fvtool(freqz(H2));
%figure(1);plot(f1,H3,'-r');
%figure(2);plot(h);
% figure(3);freqz(H2);

%% **** IMPULSIVE NOISE ****
%***Impulsive Noise Production Using Middleton Class A Method ***
% Data reception

m = 10 ; %input('Please enter the number of noise producer divice(s)
:\n') ;
A = 10 ; %input('Please enter the value of A :\n' ) ;
Rho = 0.001; %input ( ' Please eneter the value of Rho :\n');
sigma = 1; %input ('Please enter the value of sigma :\n' ) ;

%% Calculatons

N0 = 2 * (sigma^2) ;
nn=((numel(cext_data)))/2 ;
for i=0:nn ;
    for j=1:m ;
        temp(j)= exp(-
A) * ((A^j) / (factorial(j)*pi*N0)) * ((A*(Rho+1)) / (j+(A*Rho))) * exp(-
(A*(1+Rho)*(abs(i)^2)) / ((j+(A*Rho))*N0));
    end
    P(i+1) = sum(temp)+ (exp(-A) * ((1+Rho) / (Rho*pi*N0)) * exp(-
((1+Rho)*(abs(i)^2)) / Rho*N0));
end
% these following 3 lines make a cocurrent matrix for impulsive noise
Impulsive_Noise=ones(1,n);
Impulsive_Noise(1:(n)/2)=P(end:-1:2);
Impulsive_Noise((n)/2+1:1:end)=P(1:end-1) ;

%% Plotting the results
figure(6)
title('Impulsive Noise')
plot(0:1:nn,P, '-*')
hold on
plot(0:-1:-nn,P, '-*')
grid on

```

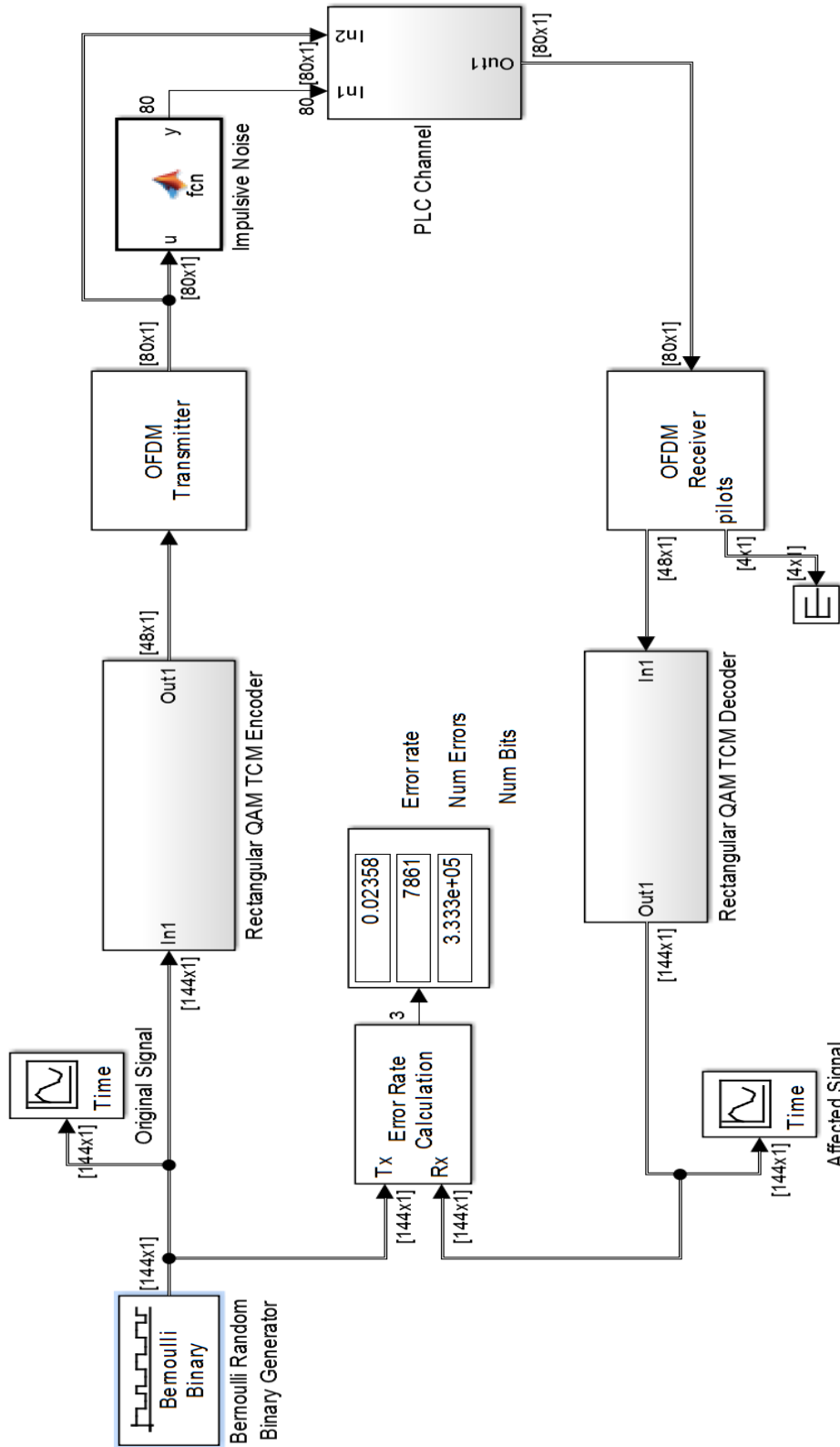

Rectangular 16 QAM TCM based on OFDM system model

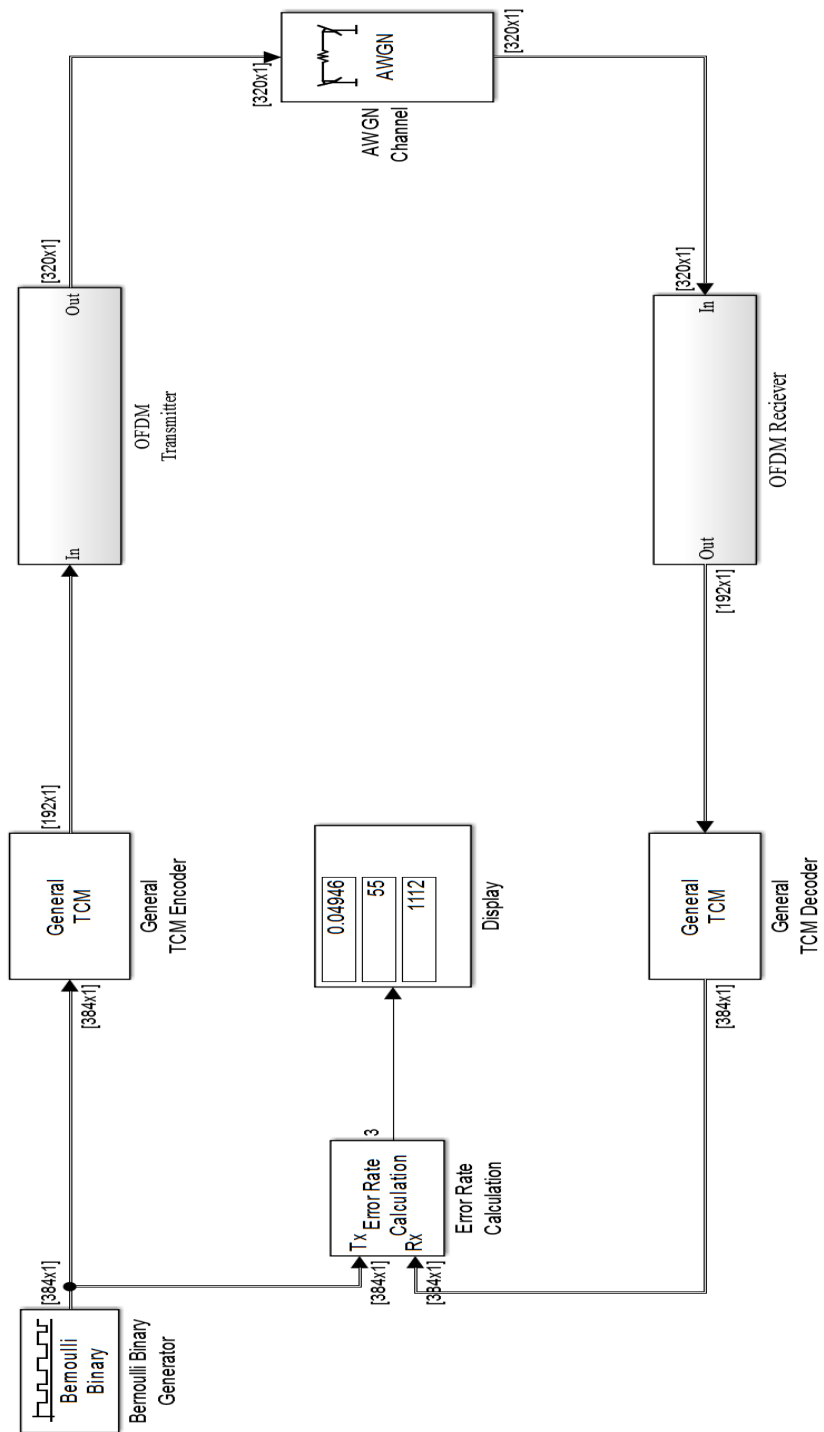

TCM OFDM model on PLC system in presence AWGN noise

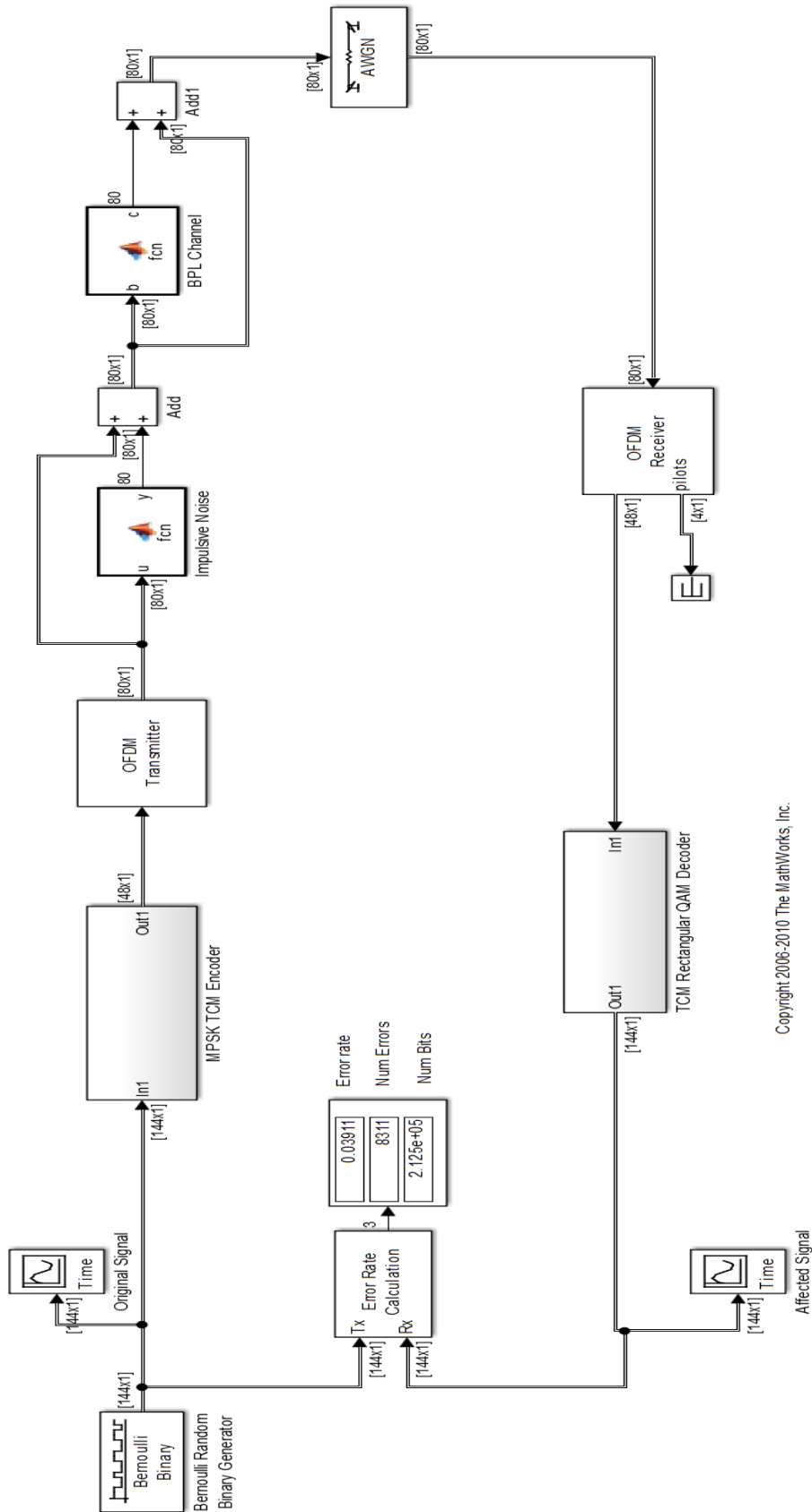

Copyright 2006-2010 The MathWorks, Inc.

TCM OFDM model on PLC system in presence of Middleton Class A and AWGN noise