



University of East London Institutional Repository: <http://roar.uel.ac.uk>

This paper is made available online in accordance with publisher policies. Please scroll down to view the document itself. Please refer to the repository record for this item and our policy information available from the repository home page for further information.

Author(s): Matieni, Xavier; Dodds, Stephen J.; Lee, Sin W.

Title: Closed-loop control using a backpropagation algorithm: a practicable approach for energy loss minimisation in electrical drives.

Year of publication: 2010

Citation: Matieni, X., Dodds, S.J. and Lee, S.W. (2010) 'Closed-loop control using a backpropagation algorithm: a practicable approach for energy loss minimisation in electrical drives.', Proceedings of Advances in Computing and Technology, (AC&T) The School of Computing and Technology 5th Annual Conference, University of East London, pp.72-78.

CLOSED-LOOP CONTROL USING A BACKPROPAGATION ALGORITHM: A PRACTICABLE APPROACH FOR ENERGY LOSS MINIMISATION IN ELECTRICAL DRIVES

Xavier Matieni, Stephen J. Dodds and Sin W. Lee

School of Computing, Information Technology and Engineering, University of East London
xamat@hotmail.com, stephen.dodds@spacecon.co.uk, s.w.lee@uel.ac.uk

Abstract: In general, optimal controls are computed off line and subsequently applied in real time but this approach is impracticable due to lack of robustness with respect to the plant modelling errors and unknown external disturbances. Closed loop versions of these optimal controls could circumvent this problem but are only available in the analytical form for very simple cases, not including minimisation of frictional energy loss in motion control systems, which is the aim of the research programme. The approach suggested by Matieni and Dodds (2009), however, overcomes this obstacle by training an artificial neural network (ANN) to reproduce the optimal control values computed off-line from given states and reference inputs, thereby yielding a closed loop solution. The purpose of this paper is to present the results of an initial simulation experiment to assess the capability of a Multilayered Perceptron (MLP), in the backpropagation mode, to perform a direct state feedback function, which, to the authors' knowledge, is new. A known linear state feedback controller for a double integrator plant is used for this purpose. The control law is used to train the MLP. Then a simulation of the closed loop system formed using this MLP is compared with a simulation of the known linear state feedback control system. The results show that the closed loop step response with the MLP closely follows that of the conventional system.

1. Introduction

The long established open loop methods of Bellman et. al. (1962), known as 'Dynamic Programming', in the USA and Pontryagin (1960), a Russian mathematician, with the 'Maximum Principle', compute optimal controls off line and apply them subsequently in real time. During the period leading up to the 21st century, these methods have been abandoned by the mainstream control researchers due to the fundamental drawback of susceptibility to plant modelling errors and external disturbances and the lack of success in overcoming this drawback by deriving closed loop versions in all but the simplest and often unrealistic cases.

Bryson et. al. (1975) in his works on the numerical solution of optimal programming

and control problems, investigated the possibility of closing the loop iteratively by the gradient method. The first-order gradient and second-order gradient methods demonstrated vast improvements in the first iterations but, unfortunately, displayed poor overall convergence, which means that the optimal solution could not be obtained fast enough for real time implementation. Also Ryan (1982) stated that explicit optimal closed-loop solutions have been obtained in a variety of cases of up to fourth order but frequently exhibit a high level of complexity, which may prove to be unacceptable in many practical applications. This is especially evident in the time-optimal feedback control laws for certain third and fourth-order plants, many of which involved logarithmic and exponential functions of the plant states which are

computationally too demanding for commonly used digital processors in many control applications. He carried out investigations of third and fourth-order linear, single-input plants, and nonlinear, multi-input plants some of which exhibited such complexity that explicit closed-loop solutions are not available at the present and unlikely to be obtained in the future. The method pursued in this research programme circumvents these difficulties.

In principle, an MLP can mimic any continuous state feedback controller yielding smooth outputs. During the training process, the parameters of the network, i.e., the neuron input weights, are being adjusted to minimise the error between the desired control input, u , and the control input, u_{nn} , generated by the neural network. The ultimate aim is to use the MLP to reproduce the function of the computed optimal controls referred to above but in a closed loop control structure with the possibility of yielding some robustness against plant modelling errors and external disturbances, as proposed by Matieni and Dodds (2009). This paper, however, is restricted to a first step in which the ability of an MLP to reproduce the behaviour of a simple linear state feedback control law for a double integrator plant is investigated.

The conventional performance measure for MLP training is the mean-square error or the sum of the squared errors over the training sample. Such a performance measure is a function of the free parameters of the system, i.e., the neuron input weights. This function may be visualized as a multidimensional error-performance surface with the free parameters as coordinates. It is important to note here that the MLP has really provided an approximation to a function of several variables. In the single input plant control application, it is the

control variable as a function of the plant state variables and the reference input.

2. Simulation of the MLP realisation of linear state feedback control of a double plant:

A linear second order plant model is accurate enough for many real applications found in the fields of spacecraft control; chemical process control, bio-engineering, aircraft control, etc. This justifies the use of a double integrator plant for this initial investigation. Fig. 1 shows the Simulink block diagram of the conventional linear state feedback control, used as a standard of comparison for the trained MLP controller.

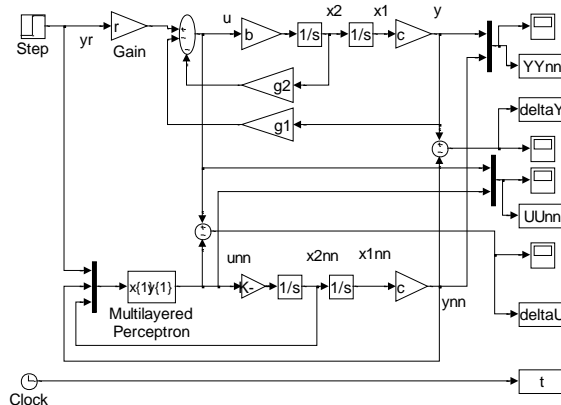

Fig. 1: Simulink diagram of MLP based control of a double integrator plant together with conventional control as bench mark.

The plant states, x_1 and x_2 are available to the conventional linear state feedback control law and the plant states, x_{1nn} and x_{2nn} , are available to the MLP based control law, together with the reference input y_r . Applying Mason's rule to derive the desired closed loop transfer function for the conventional system yields

$$\frac{y}{y_r} = \frac{rbc}{s^2 + bg_2s + bg_1} \quad (1)$$

The controller parameters are chosen to yield a non-overshooting step response with

unity DC gain and a settling time (5% criterion) using the 5% settling time formula of Dodds (2008) with n= 2:

$$T_s = 1.5 \left(1 + n \right) T_c \Big|_{n=2} = 4.5 T_c = 9/2 T_c \quad (2)$$

where T_c is the time constant of the identical first order cascaded subsystems of which the required closed loop system can be considered to be composed. Hence the desired closed loop transfer function is:

$$\frac{y}{y_r} = \frac{s}{s + 1/T_c} = \left(\frac{1/T_c}{s + 1/T_c} \right)^2 = \left(\frac{9/2 T_c}{s + 9/2 T_c} \right)^2$$

$$= \frac{81/4 T_s^2}{s^2 + 9/T_s s + 81/4 T_s^2} \quad (3)$$

Comparing (1) and (3) then yields the controller gains

$$g_1 = \frac{81}{4bT_s^2}, \quad g_2 = \frac{9}{bT_s} \quad (4)$$

and the reference input scaling coefficient

$$r = \frac{81}{4bcT_s^2}$$

The closed loop control law is then

$$u = r y_r - g_1 x_1 - g_2 x_2 \quad (5)$$

With the same plant states x_1 , x_2 and the reference input, y_r , the MLP controller will be trained to reproduce an input variable, u_{nn} , of the same value as u from the conventional controller, using (5).

The m-file used for the MLP training is as follows:

M-file

%% Position control

c=5

b=3

%% Demanded settling time [s]

Ts=0.2

g1=81/(4*b*Ts^2*c)

g2=9/(b*Ts)

r=81/(4*b*Ts^2*c)

```
yr=[1 -1 1 -1 1 -1 1 -1 1 -1 1 -1 1 -1 1 -1 1
1 1 1 0 0 -1 0 1 -1 -1 1 0 -1 -2 2 -2 2 1 2 1 1
-1 0 2 -2 2 2 -1 2 3 -3]
```

```
x1=[0 0 .0455 -.0455 .1074 -.1074 .1503 -
.1503 .1749 -.1749 .1878 -.1878 .1942 -
.1942 .2 -.2 0 0 0 1 -1 1 0 1 -1 1 -1 0 1 -1 0 1
0 -2 -2 -2 2 2 -1 -1 2 0 0 2 -2 -2 1 2 -3]
```

```
x2=[0 0 1.6466 -1.6466 1.3389 -1.3389
.8165 -.8165 0.4426 -0.4426 .2250 -.2250
0.1098 -0.1098 0 0 0 0 1 0 -1 -1 1 0 -1 1 -1 -
1 -1 1 1 0 -2 -2 0 0 2 -2 2 2 0 0 0 -2 1 -2 -2 -
1 2]
```

```
u=r*yr-g1*x1-g2*x2
```

```
%neural network controller which copies the
behavior of the conventional controller
given yr, x1 and x2
```

```
% conjugate gradient method which belongs
to a class of second -order optimisation
methods known as conjugate-direction
methods, is used in its particular version of
Fletcher-Reeves formula.
```

```
p = [yr;x1;x2];
```

```
t = [u];
```

```
net=newff(minmax(p),[30,1],{'tansig','purelin'},
'traincgf');
```

```
net.trainParam.show =49;
```

```
net.trainParam.epochs = 100;
```

```
net.trainParam.goal = 0.25;
```

```
net.trainParam.time=inf;
```

```
net.trainParam.min_grad=1e-6;
```

```
net.trainParam.max_fail=5;
```

```
net.trainParam.searchFcn='srchcha';
```

```
net.trainParam.scal_tol=20;
```

```
net.trainParam.alpha=0.001;
```

```
net.trainParam.beta=0.1;
```

```
net.trainParam.delta=0.01;
```

```
net.trainParam.gama=0.1;
```

```
net.trainParam.low_lim=0.1;
```

```
net.trainParam.up_lim=0.5;
```

```
net.trainParam.maxstep=100;
```

```
net.trainParam.minstep=1.0e-6;
```

```
net.trainParam.bmax=1;
```

```
[net,tr]=train(net,p,t);
```

```
u_nn = sim(net,p);
```

```
gensim(net,-1)
```

Table 1 shows the data used for the MLP training which defines an operational envelope within which the closed loop system will lie during execution of the step response used for the investigation. The last column shows the error between the control variable generated by the MLP and the conventional linear state feedback controller.

Table 1: Data used to produce the target values of u and the error $u - u_{nn}$

y_r	1	-1	1	-1
x_1	0	0	0.455	-0.455
x_2	0	0	1.6466	-1.6466
u	33.75	-33.75	-	6.30525
			6.30525	
u_{nn}	33.656	-33.6343	-	8.2399
	5		7.2185	
error	0.093	-0.1157	0.9132	-1.9346
	5		5	

y_r	1	-1	1	-1
x_1	0.1074	-0.1074	0.1503	-0.1503
x_2	1.6466	-1.3389	0.8165	-0.8165
u	10.04175	-10.0418	16.4299	-16.430
u_{nn}	10.2262	-10.1334	17.0444	-17.373
error	-0.18445	0.09165	0.61452	0.94283

y_r	1	-1	1
x_1	0.1749	-0.1749	0.1878
x_2	0.4426	-0.4426	0.225
u	21.20813	-21.2081	24.03675
u_{nn}	20.4464	-21.3289	24.4422
error	0.761725	0.120775	-0.40545

y_r	-1	1	-1
x_1	-0.1878	0.1942	-0.1942
x_2	-0.225	0.1098	-0.1098
u	-24.0368	25.54875	-25.5488
u_{nn}	-23.4649	25.9755	-25.4952
error	-0.57185	-0.42675	-0.05355

y_r	1	-1	1	-1
x_1	0.2	-0.2	0	0
x_2	0	0	0	0

u	27	-27	33.75	-33.75
u_{nn}	26.7435	-	33.6565	-33.63
		27.821		
error	0.2565	0.821	0.0935	-0.1157

The control value, u_{nn} , produced by the MLP controller is a fairly close approximation of the one from the conventional controller. As would be expected, this yields an MLP based control system step response that is close to the step response of the conventional control system, as is evident in Fig. 2.

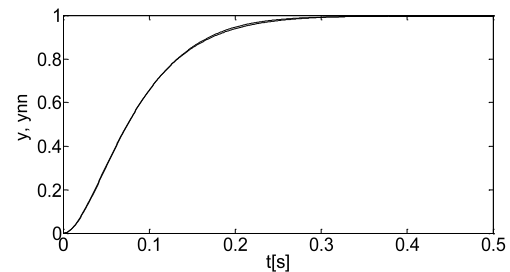

Fig. 2: Superimposed step responses of the conventional and MLP based state feedback controllers with a settling time of $T_s=0.2[s]$.

Fig. 3 shows the relatively small error between these step responses.

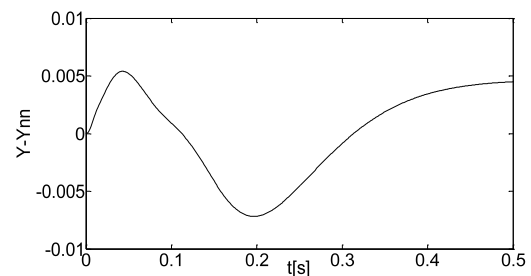

Fig. 3: Error, $y - y_{nn}$

Fig. 4 shows a plot of the corresponding control variables from the conventional and MLP based controllers.

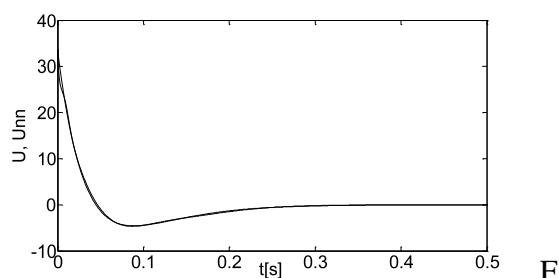

Fig. 4: Control variables from conventional and MLP based control laws

Fig. 5 shows the error between these controls.

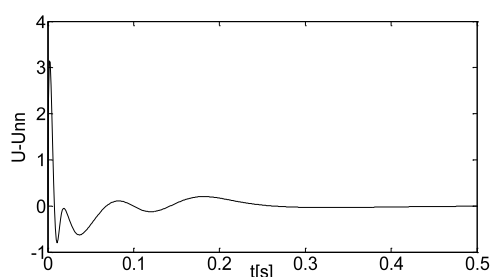

Fig. 5: Control error, $u - u_{min}$

It is important to realise that the errors shown in Table 1 are only for the training points while the errors of Fig. 5 indicate the interpolation ability of the MLP because the states presented to the MLP during the simulation are not the same as those presented to it during the training.

These results demonstrate the success of the training process. The performance, of course, is affected by the accuracy of the approximation achieved during the training and this is monitored during execution of the Matlab MLP training software by means of the plot shown in Fig. 6 which displays the mean square error versus the training time (epochs). It is evident that the error decreases very rapidly to the acceptably small value selected as an input parameter of the software.

Fig. 7 shows plots from the training software for analysis of the network response with respect to training, validation, and test. The task is to put the entire data set through the

network and then perform the linear regression between the network outputs and the corresponding targets.

In this case, the outputs are tracking the target with acceptable accuracy and the R-values, i.e., the correlation coefficients, are: Training=1, Validation=0.99412, and Test=0.9898 with an average of $R=0.99762$.

3. Further observations:

It was found that the backpropagation with the gradient descent algorithm is generally very slow because it requires small learning rates for stable learning.

From the authors experience of previous simulations, it appears that networks are sensitive to the number of neurons in their hidden layers. Too few neurons can lead to underfitting. Too many neurons can contribute to overfitting, in which all the training points are well fitted, but the fitting curve oscillates wildly between these points.

4. Conclusions and Recommendations:

The overall result shows that the MLP has been used to directly close the loop with a good approximation to the linear state feedback control law.

Since optimal control laws respecting control saturation constraints are nonlinear, the next step is to investigate the ability of the MLP to reproduce the well known time optimal state feedback control of a double integrator plant. Successful completion of this task will lead to the investigation of closed loop MLP control minimising the frictional energy wastage in an electric drive, the training data being generated from optimal control calculations using Pontryagin's method.

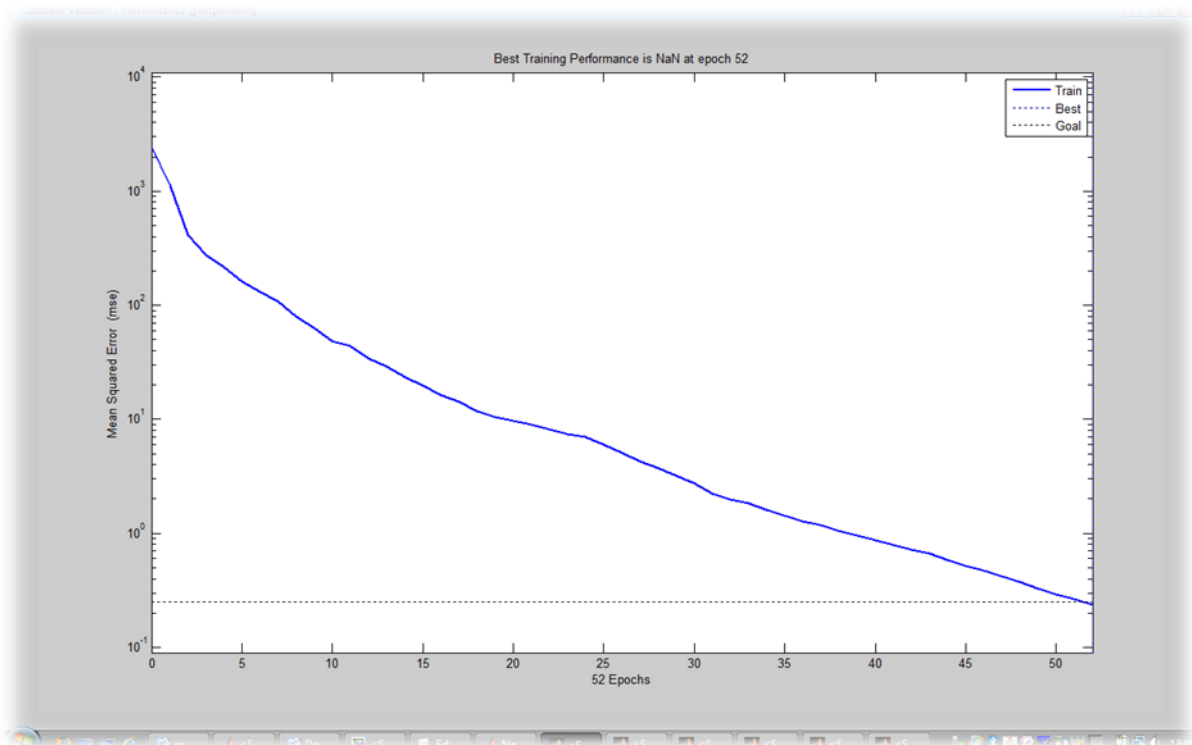

Fig. 6: Performance at 52 epochs showing that the target has been met

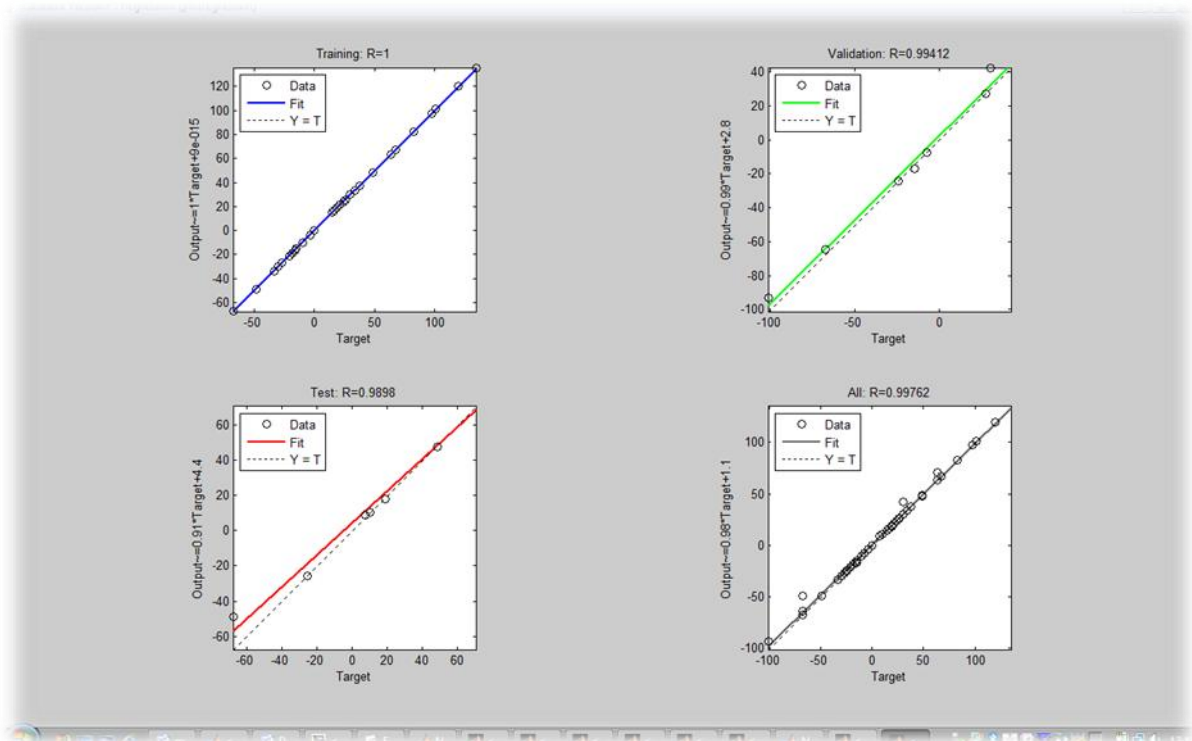

Fig 7: Linear regression

5. References:

Bellman R., Dreyfus S. E., *Applied Dynamic Programming*, Princeton University Press, Princeton, NJ, 1962.

Bryson E. A., Ho Y. C., *Applied Optimal Control: Optimization, Estimation, and Control*, Harvard University Press, Cambridge, Mass., 1975.

Matieni X., Dodds, S. J., Comparison of Fixed Final Time Optimal Control Computational Methods with the view to Closed Loop Implementation using Artificial Neural Networks, *Proceedings of AC&T*, University

of East London, 2009.

Pontryagin L. S., *The Mathematical Theory of Optimal Processes, I. The Maximum Principle*, Izv, Akad. Nauk, SSR, Ser. Mat. 24, 3, 1960.

Ryan, E. P., *Optimal relay and saturating control system synthesis*.-IEE Control Engineering Series, 1982

Dodds,,S. J., 'Settling Time Formulae for the Design of Control Systems with Linear Closed Loop Dynamics', *Proceedings of AC&T SCOT*, University of East London, UK, ISBN 0-9550008-5-8, 2008.