

Chicago-Kent College of Law

## Scholarly Commons @ IIT Chicago-Kent College of Law

---

All Faculty Scholarship

Faculty Scholarship

---

1-1-2014

### Judicial Capacities and Patent Claim Construction: An Ordinary Reader Standard

Gregory Reilly

IIT Chicago-Kent College of Law, greilly1@kentlaw.iit.edu

Follow this and additional works at: [https://scholarship.kentlaw.iit.edu/fac\\_schol](https://scholarship.kentlaw.iit.edu/fac_schol)



Part of the [Law Commons](#)

---

#### Recommended Citation

Gregory Reilly, *Judicial Capacities and Patent Claim Construction: An Ordinary Reader Standard*, 20 Mich. Telecomm. & Tech. L. Rev. 243 (2014).

Available at: [https://scholarship.kentlaw.iit.edu/fac\\_schol/874](https://scholarship.kentlaw.iit.edu/fac_schol/874)

This Article is brought to you for free and open access by the Faculty Scholarship at Scholarly Commons @ IIT Chicago-Kent College of Law. It has been accepted for inclusion in All Faculty Scholarship by an authorized administrator of Scholarly Commons @ IIT Chicago-Kent College of Law. For more information, please contact [jwenger@kentlaw.iit.edu](mailto:jwenger@kentlaw.iit.edu), [ebarney@kentlaw.iit.edu](mailto:ebarney@kentlaw.iit.edu).

# JUDICIAL CAPACITIES AND PATENT CLAIM CONSTRUCTION: AN ORDINARY READER STANDARD

Greg Reilly\*

Cite as: Greg Reilly, *Judicial Capacities and Patent Claim Construction: An Ordinary Reader Standard*,  
20 MICH. TELECOMM. & TECH. L. REV. 243 (2014).  
*This manuscript may be accessed online at repository.law.umich.edu.*

*Patent claim construction is a mess. The Federal Circuit's failure to provide adequate guidance has created significant problems for the patent system. The problems with claim construction result from the Federal Circuit's inability to resolve whether claim terms should be given (1) the general, acontextual meaning they would have to a skilled person in the field; (2) the specific meaning they have in the context of the patent; or (3) some combination of the two. The claim construction debate largely overlooks the generalist judges who must implement claim construction. This Article fills that gap, concluding that existing approaches are difficult, costly, and error prone for generalist judges because they force the judge to step into the shoes of a scientist. It is time to abandon the legal fiction that claims should be construed from the perspective of a skilled person in the field—instead, judges should construe claims from the perspective of an ordinary reader discerning meaning from the context of the patent. The ordinary reader standard is more familiar to generalist judges, easier and cheaper to apply, and less error prone. Perhaps surprisingly, it is also consistent with the nature of claim construction. Rather than eliminate technical context, an ordinary reader standard focuses on the technical context that was provided by the patentee, is publicly available to everyone, and by definition reflects the skill level, field, and time of the invention. And,*

---

\* Harry A. Bigelow Teaching Fellow and Lecturer in Law, University of Chicago Law School. Thanks to Daniel Abebe, Douglas Baird, Anya Bernstein, Alex Boni-Saenz, Vince Buccola, Tony Casey, Roger Ford, Todd Henderson, Aziz Huq, Saul Levmore, Oskar Liivak, Jonathan Masur, Jennifer Nou, John Rappaport, Erin Reilly, David Schwartz, Victoria Schwartz, Lior Strahilevitz, and participants at the University of Chicago Law School Research Colloquium, 2013 Works in Progress in Intellectual Property (WIPIP) Conference at Seton Hall University School of Law, and the Third Annual Patent Conference (“PatCon3”) at the IIT Chicago-Kent College of Law for helpful discussions and suggestions on this and earlier versions of the paper. In private practice, I participated in the following cases discussed or cited in this Article: *Arlington Industries, Inc. v. Bridgeport Fittings Inc.*; *St. Clair Intellectual Property Consultants, Inc. v. Matsushita Elec. Indus. Co.*; and *St. Clair Intellectual Property Consultants, Inc. v. Canon, Inc.* This Article relies exclusively on publicly-available information regarding these cases and reflects solely the personal views of the author.

*rather than ignore the audience for patent claims, it provides a common ground for the varied consumers of modern patent claims: skilled people, business people, patent examiners, lawyers, and judges.*

#### TABLE OF CONTENTS

|                                                                                        |     |
|----------------------------------------------------------------------------------------|-----|
| TABLE OF CONTENTS .....                                                                | 244 |
| INTRODUCTION .....                                                                     | 244 |
| I. PATENT CLAIM CONSTRUCTION .....                                                     | 249 |
| A. <i>The Anatomy of a Patent</i> .....                                                | 250 |
| 1. The Specification .....                                                             | 250 |
| 2. The Claims .....                                                                    | 253 |
| 3. Patent Prosecution .....                                                            | 255 |
| B. <i>Interpreting Patent Claims</i> .....                                             | 256 |
| 1. The Importance of Claim Construction .....                                          | 256 |
| 2. Claim Construction Rules .....                                                      | 257 |
| II. THE FEDERAL CIRCUIT'S CLAIM CONSTRUCTION SPLIT .....                               | 260 |
| A. <i>A Division Over General or Specific Meaning</i> .....                            | 260 |
| B. <i>The Importance of General or Specific Meaning</i> .....                          | 264 |
| C. <i>The Missing Question of Generalist Judges</i> .....                              | 266 |
| 1. Interpretive Choice and Judicial Capacities .....                                   | 267 |
| 2. Institutional Choice or Interpretive Choice? .....                                  | 269 |
| III. GENERALIST JUDGES AND GENERAL MEANING .....                                       | 270 |
| A. <i>Generalist Judges and "Plain" Meaning</i> .....                                  | 271 |
| 1. The Difficulties of Determining General Meaning ..                                  | 271 |
| 2. Consequences of Errors .....                                                        | 276 |
| B. <i>Generalist Judges and the Phillips Approach</i> .....                            | 277 |
| IV. GENERALIST JUDGES, SPECIFIC MEANING, AND AN ORDINARY<br>READER STANDARD .....      | 279 |
| A. <i>Generalist Judges and the Focus on the Disclosed<br/>        Invention</i> ..... | 280 |
| 1. Problems with Disclosed Invention .....                                             | 280 |
| 2. Consequences of Errors .....                                                        | 282 |
| B. <i>Generalist Judges and the Ordinary Reader Standard</i> ..                        | 283 |
| 1. Simplifying Claim Construction: An Ordinary<br>Reader Standard .....                | 284 |
| 2. Obstacles to an Ordinary Reader Standard .....                                      | 288 |
| C. <i>The Ordinary Reader Standard and Claim Construction<br/>        Values</i> ..... | 294 |
| 1. Predictability .....                                                                | 295 |
| 2. Proportionality .....                                                               | 296 |
| CONCLUSION .....                                                                       | 298 |

#### INTRODUCTION

To overcome problems resulting from file format incompatibilities between IBM PCs and Apple Macs in 1990, three inventors conceived of a digital camera that allowed the user to select, before taking a picture,

whether to save the image in a PC-compatible format, a Mac-compatible format, or a format compatible with another manufacturer's computer.<sup>1</sup> Though apparently useful at the time, the development of standardized image formats, like the now-ubiquitous JPEG, rendered this invention obsolete shortly after the inventors' first patent issued in 1992.<sup>2</sup>

Yet, over a ten-year period beginning in 2001, the owners of the inventors' patents, a patent assertion entity named St. Clair Intellectual Property Consultants, sued virtually every significant provider of digital cameras or camera phones.<sup>3</sup> St. Clair convinced the district court to adopt a broad interpretation of the patent claims that "cover[ed] electronic cameras that can save digital photographs in one of at least two file formats," including standardized formats compatible with any type of computer.<sup>4</sup> In doing so, the district court relied on the supposed "ordinary and accustomed meaning" of the claim terms, rather than the inventors' description of their invention in the patent.<sup>5</sup> Under this construction, the patents covered any product that captured both still pictures and video,<sup>6</sup> and St. Clair obtained jury verdicts of \$25 million, \$34.7 million, and \$3 million, as well as hundreds of millions of dollars in revenues from litigation-driven licenses.<sup>7</sup>

More than eight years after the district court adopted this broad interpretation, the United States Court of Appeals for the Federal Circuit reviewed and rejected it. Relying on the patent's description of the invention, rather than the claims' "ordinary meaning," to interpret the claim language, the Federal Circuit held that the patent claims were limited to a camera that offered two or more still image formats each specific to a particular type of computer.<sup>8</sup> Under this construction, none of the modern products accused by

---

1. See *St. Clair Intell. Prop. Consultants, Inc. v. Canon Inc.*, 412 F. App'x 270, 273-74 (Fed. Cir. 2011).

2. See Complaint for Patent Infringement Corrected Brief for Defendants-Appellants at 15, *St. Clair Intell. Prop. Consultants, Inc. v. Canon, Inc.*, 412 F. App'x 270 (Fed. Cir. 2011) (Nos. 2009-1052, 2010-1137, -1140) [hereinafter *Fujifilm Fed. Cir. Br.*]; see also U.S. Patent No. 5,138,459 (filed Nov. 20, 1990).

3. Complaint for Patent Infringement at 3-5, *St. Clair Intell. Prop. Consultants, Inc. v. Google, Inc.* (D. Del. Jan. 29, 2010) (No. 1:10-cv-00077-UNA) [hereinafter *St. Clair Google Complaint*].

4. See *St. Clair Intell. Prop. Consultants, Inc. v. Sony Corp.*, No. 01-557-JJF, 2002 WL 31051605, at \*1 (D. Del. Sept. 3, 2002).

5. *Id.*

6. See *Fujifilm Fed. Cir. Br.*, *supra* note 2, at 20-21.

7. Robert J. Gaybrick & Robert J. Hollingshead, Morgan, Lewis & Bockius LLP, *Fighting the Patent Troll at Shanghai Silicon IP Exchange*, Morgan, Lewis & Bockius LLP 10 (Sept. 27, 2007), available at [http://www.morganlewis.com/pubs/fightingpatenttroll\\_gaybrick\\_hollingshead20070927.pdf](http://www.morganlewis.com/pubs/fightingpatenttroll_gaybrick_hollingshead20070927.pdf); see *St. Clair Google Complaint*, *supra* note 3, at 3-5.

8. *St. Clair Intell. Prop. Consultants, Inc. v. Canon Inc.*, 412 F. App'x 270, 277-78 (Fed. Cir. 2011).

St. Clair violated the patent.<sup>9</sup> Aside from the \$3 million verdict under appeal, the Federal Circuit's opinion could not undo the verdicts, license fees, or litigation costs that had burdened both the camera and camera phone industries as a result of the district court's broad interpretation.

The *St. Clair* litigation is not an outlier. The academic literature and popular press recount stories of overbroad patents asserted widely to sweep in independently-developed products much different from that described in the patent.<sup>10</sup> Scholars have gone to great lengths to propose ways to eliminate so-called "bad patents,"<sup>11</sup> either by improving examination in the Patent Office or eliminating patents in litigation.<sup>12</sup> However, in many cases—arguably including *St. Clair*'s—the patents may not be inherently "bad"; rather, they may describe actual innovations that are narrow, economically trivial, or now obsolete. The problem comes when patentees exploit vagueness or ambiguities in claim language to broadly assert patents that were understood narrowly when issued by the Patent Office.<sup>13</sup>

For that reason, the interpretation of patent claims, known as claim construction, is "overwhelmingly the most critical patent issue in litigation."<sup>14</sup> Unfortunately, the Federal Circuit's claim construction precedent is an unmitigated disaster, causing *ex ante* unpredictability before litigation,<sup>15</sup> *ex post* uncertainty in litigation,<sup>16</sup> appellate panel dependence,<sup>17</sup> high reversal rates,<sup>18</sup> conflicting interpretive approaches,<sup>19</sup> overly broad claim scope,<sup>20</sup> un-

9. See *id.* at 278; *St. Clair Intell. Prop. Consultants, Inc. v. Matsushita Elec. Indus. Co.*, Nos. 04-1436-LPS, 06-404-LPS, 08-371-LPS, 2012 WL 1015993, at \*11-14 (D. Del. Mar. 26, 2012).

10. See, e.g., JAMES BESSEN & MICHAEL J. MEURER, *PATENT FAILURE: HOW JUDGES, BUREAUCRATS, & LAWYERS PUT INNOVATORS AT RISK* 4-5 (2008); Charles Duhigg & Steve Lohr, *The Patent, Used as a Sword*, N.Y. TIMES, Oct. 8, 2012, at A1.

11. Mark Lemley et al., *What to Do About Bad Patents?*, 28 REG. 10 (Winter 2005-2006).

12. See Roger Allan Ford, *Patent Invalidity Versus Noninfringement*, 99 CORNELL L. REV. 71, 87-93 (2013) (summarizing literature).

13. BESSEN & MEURER, *supra* note 10, at 56-58.

14. R. Polk Wagner & Lee Petherbridge, *Did Phillips Change Anything? Empirical Analysis of the Federal Circuit's Claim Construction Jurisprudence*, in *INTELLECTUAL PROPERTY & THE COMMON LAW* 125 (Shyamkrishna Balganesh ed., 2013).

15. See Jennifer R. Johnson, *Out of Context: Texas Digital, the Indefiniteness of Language, and the Search for Ordinary Meaning*, 44 IDEA 521, 528 (2004); Kristen Osenga, *Linguistics & Patent Claim Construction*, 38 RUTGERS L.J. 61, 64 (2006).

16. See Dan L. Burk & Mark A. Lemley, *Quantum Patent Mechanics*, 9 LEWIS & CLARK L. REV. 29, 53 (2005); Kimberly A. Moore, *Are District Court Judges Equipped to Resolve Patent Cases?*, 15 HARV. J.L. & TECH. 1, 27-28 (2001).

17. See R. Polk Wagner & Lee Petherbridge, *Is the Federal Circuit Succeeding? An Empirical Assessment of Judicial Performance*, 152 U. PA. L. REV. 1105, 1169 (2004).

18. Moore, *supra* note 16, at 27-28.

19. See Osenga, *supra* note 15, at 69-71.

20. See Dan L. Burk & Mark A. Lemley, *Fence Posts or Sign Posts? Rethinking Patent Claim Construction*, 157 U. PA. L. REV. 1743, 1762 (2009).

due formalism,<sup>21</sup> increased litigation,<sup>22</sup> disincentives to settle,<sup>23</sup> and high litigation costs.<sup>24</sup> Two leading commentators have identified the Federal Circuit's confused claim construction precedent as one of the primary causes of the "failure" of the patent system.<sup>25</sup>

The root of these problems is a fundamental split in the Federal Circuit over the methodology for claim construction. The various formulations that have been used to describe this split overshadow a core question at its heart, rarely directly acknowledged in the cases or scholarship: whether claim terms should be given the general meaning they would normally have to a skilled person in the field of the invention, the specific meaning that they have in the context of the patent itself, or some combination of the two. Put another way, Federal Circuit judges are divided over the proper context for interpreting the patent claims—the background knowledge and understanding in the field, the disclosure in the patent itself, or both.

One line of cases and scholarship emphasizes that because claim terms are interpreted from the perspective of a person having ordinary skill in the art at the time of the invention ("skilled person" or "PHOSITA"), the presumed audience for patents, they almost always should be given their acontextual general meaning to that person.<sup>26</sup> A competing line of thought agrees that judges interpret claim terms from the skilled person's perspective, but this view assumes that such a skilled person would reconcile her general knowledge and understanding with the specific context provided by the patent.<sup>27</sup> In recent years, a third approach has developed in the cases and scholarship that rejects any reliance on the acontextual general meaning a term would have in the field. Instead, this approach contends that terms should be given the meaning that captures the patentee's actual invention from the specific context of the patent.<sup>28</sup> Each of these approaches purports to promote one or both of two values: predictability in patent scope, and proportionality between patent scope and the patentee's contribution to the field.

Predictability and proportionality in patent scope derive from the economic justifications for the patent system and undoubtedly are important principles for patent claim construction. Yet identifying an optimal approach to claim construction is not as simple as determining how best in theory to promote one or both of these values. In the context of constitutional and statutory interpretation—equally applicable to patent interpretation—Adrian

---

21. *Id.* at 1745.

22. *See* Moore, *supra* note 16, at 27-28.

23. Burk & Lemley, *supra* note 16, at 53; Moore, *supra* note 16, at 27-28.

24. Moore, *supra* note 16, at 27-28.

25. BESSEN & MEURER, *supra* note 10, at 10, 57-58.

26. *See* Wagner & Petherbridge, *supra* note 14, at 144.

27. *See* Phillips v. AWH Corp., 415 F.3d 1303, 1312-13 (Fed. Cir. 2005) (en banc).

28. *See* Oskar Liivak, *Rescuing the Invention from the Cult of the Claim*, 42 SETON HALL L. REV. 1, 44 (2012).

Vermeule has concluded that “[t]he right question is not ‘How, in principle, should a legal text be interpreted?’ The question instead is ‘How should certain institutions, with their distinctive abilities and limitations, interpret certain texts?’”<sup>29</sup> To date, the claim construction debate largely has overlooked this crucial question: how should legally—but not technically—sophisticated generalist judges interpret patent claims?

From this perspective, requiring the judge to determine the general meaning of a claim term to a skilled person at the time of the invention is destined to be costly and error prone, undermining both predictability and proportionality.<sup>30</sup> To accurately determine the skilled person’s general knowledge and understanding at the time the invention was made, a generalist judge must resolve a series of difficult scientific questions, such as the precise field of the invention, the precise level of skill in the field, the knowledge possessed by a skilled person in the field, and the sources available to such a person. Often, the judge must make these determinations years after the time of the invention. The judge also must distinguish the skilled person’s understanding from the judge’s own, avoid attributing knowledge of subsequent developments to the skilled person, and separate the parties’ self-serving assertions about the technology from the reality at the time of the invention.

In light of these difficulties, it is not surprising that some recent opinions and commentary have deemphasized the general meaning of claim terms in the field at the time of the invention. Instead, these opinions and articles emphasize the meaning in the specific context of the patent. However, the patent-specific meaning that this line has adopted—the meaning that will best capture the patentee’s so-called actual invention—does not make claim construction any better suited for generalist judges. It requires generalist judges to define the patentee’s “invention” at a precise level of generality and to do so based on the varied, confusing, and often conflicting patent disclosure. The generalist judge then still must identify a claim meaning that captures exactly this “actual invention,” nothing more or less.

The opinions and commentary that favor construing claims to reflect the patentee’s “actual invention,” as determined from the specific context of the patent, have it half right. Claim construction should focus on the specific meaning in the patent disclosure, rather than the general acontextual meaning to a skilled person at the time of the invention. However, to make claim construction less costly, more constrained, and less error prone, a generalist judge should give a claim term the meaning that an ordinary reader would understand from how the specific claim term is used in the public record of the patent and prosecution history. This approach is simpler, more familiar,

---

29. ADRIAN VERMEULE, JUDGING UNDER UNCERTAINTY: AN INSTITUTIONAL THEORY OF LEGAL INTERPRETATION 36 (2006).

30. See *infra* Part III.

and better suited for legally—but not technically—sophisticated generalist judges.

Abandoning the skilled person's perspective in favor of an ordinary reader standard promotes the objectives of claim construction as well as, or better than, the idealized approaches. Rather than eliminating technical context, it promotes proportionality by relying only on the technical context indisputably related to the invention that is provided in the public record of the patent and prosecution history. It also promotes predictability by providing common ground for the varied consumers of patent claims: skilled people, business people, patent examiners, lawyers, and judges. Although there may be concerns about whether judges can identify claim term meaning just from the use of the term in the patent itself, mechanisms exist in the Patent Office rules to ensure that patentees sufficiently describe claim terms in the patent specification.

The Article proceeds in four parts. Part I introduces patents and patent claim construction for the uninitiated reader. Part II describes the Federal Circuit's persistent split over the relative roles in claim construction of the general meaning of claim terms in the technical field and the specific meaning terms bear in the patent itself. Part III evaluates general meaning approaches and finds them poorly suited for application by generalist judges. Part IV first evaluates the actual invention approach and finds it similarly poorly matched for the skills of generalist judges. Part IV then proposes the alternative ordinary reader approach and explains why it is both better suited for generalist judges and normatively desirable. A short conclusion follows.

## I. PATENT CLAIM CONSTRUCTION

Interpreting a patent claim is similar in many ways to interpreting a statute, contract, or other legal document. Courts and scholars addressing patent claim construction have sometimes looked to the interpretive rules and interpretive debates from these other contexts,<sup>31</sup> though probably not as much as they should.<sup>32</sup> At the same time, a patent includes unique features not easily analogized to other legal documents and claim construction has developed its own language, theories, and rules. A brief primer on patents and patent claim construction follows.

---

31. See, e.g., *Markman v. Westview Instruments, Inc.*, 52 F.3d 967, 987 (Fed. Cir. 1995) (en banc), *aff'd*, 517 U.S. 370 (1996) (statutory interpretation); *id.* at 997 (Mayer, J., concurring in judgment) (contract and deed interpretation); Craig Allen Nard, *A Theory of Claim Interpretation*, 14 HARV. J.L. & TECH. 1, 3 (2000) (contract and statutory interpretation).

32. See, e.g., Rochelle Cooper Dreyfuss, *The Federal Circuit as an Institution: What Ought We to Expect*, 43 LOY. L.A. L. REV. 827, 835 (2010).



### A. *The Anatomy of a Patent*

A United States patent has two primary parts: the written description and the claims. The Patent Act expressly connects these two parts, explaining that the patent “specification shall contain a written description of the *invention*” and “shall conclude with one or more claims particularly pointing out and distinctly claiming the subject matter which the inventor or a joint inventor regards as the *invention*.”<sup>33</sup> Although both parts are directed at the “invention,” their content and function are significantly different.

#### 1. The Specification

The written description, commonly referred to by the more generic term specification,<sup>34</sup> is “rich with invention-specific information,”<sup>35</sup> including: a description of “the precise invention” at various levels of generality, the existing knowledge and work in the technological field (known as “prior art”) and how the invention differs from it, working examples (known as “embodiments”), how to make and use the invention, and the best way the patentee knows of building or implementing the invention (known as the “best mode”).<sup>36</sup> The extensive information provided in the specification is the “*quid pro quo*” that justifies the exclusive rights granted by the patent.<sup>37</sup>

The patent begins with a title that describes the “invention” at a high level of generality in a “brief but technically accurate and descriptive” way.<sup>38</sup> The cover page also includes an abstract of the disclosure that concisely summarizes the technical disclosure and the innovative aspects of the invention.<sup>39</sup> Several illustrations—detailed figures, diagrammatic views, chemical or mathematical formulas, tables, or flow charts—normally follow the cover page to help “facilitate an understanding of the invention.”<sup>40</sup> These illustrations may be of the “invention,” but they also may illustrate specific working examples or show existing devices for the purpose of distinguishing the invention from the prior art. The following is an example from the St. Clair patent:<sup>41</sup>

---

33. 35 U.S.C. § 112(a)-(b) (2012) (emphasis added).

34. See, e.g., Christopher A. Cotropia, *Patent Claim Interpretation Methodologies & Their Claim Scope Paradigms*, 47 WM. & MARY L. REV. 49, 61 n.29 (2005).

35. Christopher A. Cotropia, *Patent Claim Interpretation & Information Costs*, 9 LEWIS & CLARK L. REV. 57, 70 (2005).

36. 35 U.S.C. § 112(a); 37 C.F.R. § 1.71(b) (2013); see Cotropia, *supra* note 35, at 69-70. *But cf.* Tun-Jen Chiang, *The Levels of Abstraction Problem in Patent Law*, 105 NW. U. L. REV. 1097, 1118 (2011) (suggesting that the specification only describes a “tangible and working embodiment” of the invention).

37. *Ariad Pharms., Inc. v. Eli Lilly & Co.*, 598 F. 3d 1336, 1345 (Fed. Cir. 2010) (en banc); Jeanne C. Fromer, *Patent Disclosure*, 94 IOWA L. REV. 539, 548-53 (2009).

38. MPEP § 606 (8th ed., Rev. 9, Aug. 2012).

39. *Id.* § 608.01(b)(B).

40. 37 C.F.R. §§ 1.81(b), 1.84(d); Cotropia, *supra* note 35, at 70-72.

41. U.S. Patent No. 5,138,459 fig. 14A (filed Nov. 20, 1990).

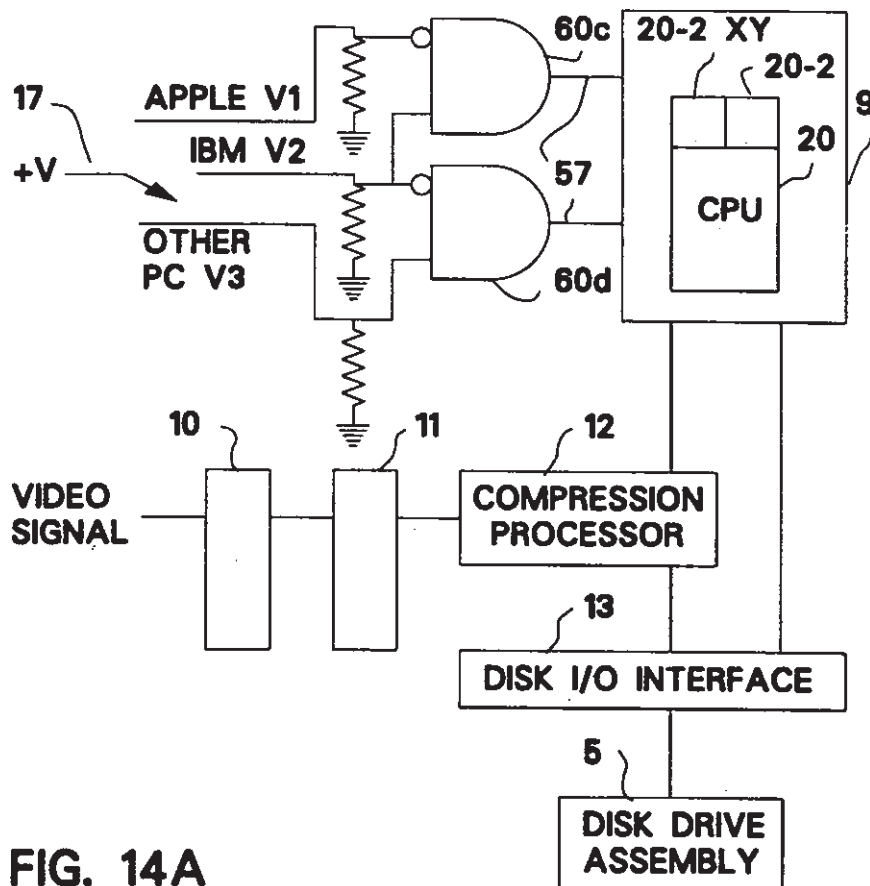

**FIG. 14A**

The core of the specification starts with a “Background of the Invention” identifying the technical field of the invention, the problem in the field that the invention addresses, existing knowledge about this problem, and prior attempts to solve it.<sup>42</sup> The following excerpts from the Background of the St. Clair patent are representative:

This invention generally relates to an electronic still video camera and in particular to an improved electronic still camera which converts a still picture of an object or scene into an operator selectable compressed digital signal format for storage utilizing a compression/decompression algorithm, such as the Joint Photographic Experts Group (JPEG) algorithm standard for example, formatted into Personal Computer (PC) compatible format retaining the images’ color information, and stored on a PC compatible memory diskette. . . .

42. 37 C.F.R. § 1.71(b); MPEP *supra* note 38, § 608.01(c).

With the current state of the art, it is expensive and time consuming to convert the analog image equivalent to a digital format for direct utilization with PC software applications.<sup>43</sup>

The Background is followed by a “Summary of the Invention” setting forth “the nature and gist of the invention or the inventive concept.”<sup>44</sup> The “Summary of the Invention” often describes the “objects” of the invention, which are the reasons that the invention is useful, and/or the key features of the invention, which are either described as features of the “present invention” or as only features of an “aspect” or “embodiment.”<sup>45</sup> Again, the following excerpt from the St. Clair patent is representative:

It is the object of this invention to provide an improved electronic still camera with operator selectable picture compression in one of a plurality of operator selectable digital data formats recordable on a standard removeable magnetic diskette common to personal computers.

It is a further object of this invention to provide an improved electronic still camera that provides digital image files for immediate and direct incorporation into popular word processing, desktop publishing, and other software programs on PCs.<sup>46</sup>

The “Detailed Description of Invention” composes the bulk of the specification.<sup>47</sup> The Detailed Description describes the invention in “such particularity as to enable any person skilled in the pertinent art or science to make and use the invention without involving extensive experimentation.”<sup>48</sup> It often includes details about materials, manufacturing or chemical processes, experiments, etc.<sup>49</sup> It also must describe completely a specific working example, or embodiment, of the invention, and it often has several such examples that describe different features or components or different commercial or industrial applications.<sup>50</sup> One of these examples normally also satisfies the requirement that the inventor disclose the “best mode,” or best way, of carrying out the invention, which often requires detailed information about dimensions, tools, preferred materials, etc.<sup>51</sup>

---

43. U.S. Patent No. 5,138,459 col. 1 ll. 8-60 (filed Nov. 20, 1990).

44. MPEP, *supra* note 38, §§ 608.01(a) ¶ 6.02(g), 608.01(d).

45. MPEP, *supra* note 38, § 608.01(d).

46. U.S. Patent No. 5,138,459 col. 2 ll. 9-19.

47. MPEP, *supra* note 38, § 608.01(g).

48. *Id.*

49. Cotropia, *supra* note 35, at 76-77.

50. 37 C.F.R. § 1.71(b) (2013).

51. *Id.* Congress recently amended the best mode requirement as part of the America Invents Act. Applicants must continue to disclose the best mode they know of carrying out the invention, but failure to do so is no longer a ground for patent invalidity in subsequent litigation. Lee Petherbridge & Jason Rantanen, *In Memoriam Best Mode*, 64 STAN. L. REV. ONLINE

Thus, the patent specification is full of useful technical information about the invention.<sup>52</sup> At the same time, it is “sanitized, modulated, or otherwise transformed by the legal pencil,” resulting in a “jumble of legal and technical assertions, making it excessively hard for the technical expert to comprehend the invention’s technical aspects through the patent.”<sup>53</sup> The specification will often use “broad or ambiguous phrasings to maximize the probability of extensive patent protection in the face of ever-changing technological conditions.”<sup>54</sup> Relatedly, the patentee may use specialized terminology, called “patentese,” developed by patent prosecutors to cast the invention in broad terms and avoid poor word choices that have unintended consequences.<sup>55</sup> Ultimately, “patentees rationally have little to no incentive to offer more information than the patent laws require and have an incentive to obfuscate information they provide whenever possible.”<sup>56</sup> Doing so limits competitors’ efforts to design around the patent, develop improvements, or practice the invention after the patent expires.

## 2. The Claims

The patent ends with one or more “claims” that “particularly point[ ] out and distinctly claim[ ] the subject matter which the applicant regards as his invention.”<sup>57</sup> “It is a bedrock principle of patent law that the claims define the invention to which the patentee is entitled the right to exclude.”<sup>58</sup> In doing so, claims perform two closely related functions. First, they substantively define the patentee’s right to exclude, so that the patentee has no rights except that which falls within the scope of the claims.<sup>59</sup> Second, they provide public notice of the exact boundaries of the patentee’s exclusive rights, so that, in theory, the public can read the claims and know what activities are reserved to the patentee and what remain open to the public.<sup>60</sup>

---

125, 126-27 (2012), available at <http://www.stanfordlawreview.org/sites/default/files/online/articles/64-SLRO-125.pdf>.

52. See Cotropia, *supra* note 35, at 84-85.

53. Fromer, *supra* note 37, at 567-68; Sean B. Seymour, *The Teaching Function of Patents*, 85 NOTRE DAME L. REV. 621, 638-39 (2010).

54. Fromer, *supra* note 37, at 568.

55. Seymour, *supra* note 53, at 633-38 (giving the example of a patent that described the simple scientific concept of “a primary or secondary alcohol” as “an alcohol having at least one hydrogen atom attached to the carbon atom bearing the hydroxyl substituent to the corresponding carbonyl compound”).

56. Fromer, *supra* note 37, at 552-53.

57. 35 U.S.C. § 112(b) (2012).

58. See *Phillips v. AWH Corp.*, 415 F.3d 1303, 1312-13 (Fed. Cir. 2005) (en banc) (internal quotation marks omitted).

59. See Cotropia, *supra* note 34, at 65.

60. See *id.* at 62-65.

Claims are numbered, single sentences—though often long and convoluted—that summarize the invention for which protection is sought.<sup>61</sup> A claim normally starts with a preamble that describes the type of invention (device, process, system, diagnostic, etc.) or the technical field of the invention and then includes a list of several “elements” or “limitations,” which are the steps or parts that the patentee considers necessary to its invention.<sup>62</sup> The patent normally includes several claims, which may vary in scope by including more or fewer limitations or vary in the words or structure they use to express and describe the invention.<sup>63</sup> By doing so, the patentee can both maximize the reach of its patent and protect itself by increasing the chances that at least one of the claims will cover a competitor’s product and not encroach on the prior art. The following claim from the St. Clair patent is representative:

For use in an electronic camera having an image pick-up unit and a storage device, a process for taking and storing digital pictures, the process comprising:

selecting one of a plurality of computer image file formats in the camera;

generating a digital image signal corresponding to an image incident on the image pick-up unit;

formatting the digital image signal in the selected computer image file format; and

storing the formatted computer image file in the storage device.

Claims are even more difficult to understand than the specification. Claims must describe complex and extensive technical concepts in a single sentence and therefore naturally use shorthand, general terminology, and incomplete descriptions, as well as unusual and difficult to follow structures.<sup>64</sup> Moreover, because claims describe technical content but have legal effect, they are often “an amalgam of multiple vocabularies and perspectives,” using ordinary English, conventions of claim drafting (*i.e.*, “patentese”), and scientific or technical words.<sup>65</sup> Patentees have the incentive to exacerbate these inherent difficulties by using vague and ambiguous terminology, which can be read narrowly to avoid the prior art when obtaining the patent

---

61. See ROBERT PATRICK MERGES & JOHN FITZGERALD DUFFY, *PATENT LAW & POLICY: CASES & MATERIALS* 26, 29 (5th ed. 2011).

62. See F. SCOTT KIEFF ET AL., *PRINCIPLES OF PATENT LAW: CASES & MATERIALS* 90-91 (5th ed. 2011).

63. See *id.* at 91.

64. See Jeanne C. Fromer, *Claiming Intellectual Property*, 76 U. CHI. L. REV. 719, 762 (2009).

65. Peter S. Menell et al., *Patent Claim Construction: A Modern Synthesis and Structured Framework*, 25 BERKELEY TECH. L.J. 711, 720 (2010).

and broadly to cover a competitor's product in subsequent licensing negotiations or litigation.<sup>66</sup> There is near-universal consensus that patent claims fail to adequately perform their public notice function,<sup>67</sup> either because of inherent difficulties in "peripheral claiming," *i.e.*, using words to define the outer boundaries of the patentee's rights,<sup>68</sup> or inadequate guidance on claim construction.<sup>69</sup>

### 3. Patent Prosecution

To obtain a patent, an inventor must file a patent application with the United States Patent and Trademark Office ("Patent Office"). The patent application is usually written by a registered patent attorney (known as a "patent prosecutor"). A patent prosecutor normally has a technical background, though his or her background may be in a different technical field than the invention and frequently will not be as extensive as people actually working in the field of the invention.<sup>70</sup> The prosecutor drafts the specification and claims with the input of the inventor.<sup>71</sup> Because the specification is directed more to a technical description of the invention, the inventor often plays an important role in the drafting of the specification. On the other hand, patent claims are legal creatures whose primary function is to demarcate legal boundaries. Therefore, the patent prosecutor—as a lawyer involved in the drafting process—will often have near-sole control over the drafting of the claims.<sup>72</sup>

The patent application is reviewed by a Patent Office examiner to determine whether it satisfies the statutory requirements for a patent. The examiner normally has some background in at least the general field of the invention but likely less than people actively working in the field.<sup>73</sup> In particular, the examiner will determine whether the invention disclosed in the patent application is an advance over the prior art and whether the patent application provides sufficient disclosure of the invention.<sup>74</sup> Following a detailed set of procedures, directions, and guidance contained in the Manual of Patent Examining Procedure, the examiner often will issue one or more "Of-

---

66. See BESSEN & MEURER, *supra* note 10, at 56-57; Burk & Lemley, *supra* note 20, at 1753.

67. Fromer, *supra* note 61, at 762.

68. See *id.* at 731-32; see also Burk & Lemley, *supra* note 20.

69. See BESSEN & MEURER, *supra* note 10, at 58.

70. See Menell et al., *supra* note 65, at 719.

71. See *id.* In corporate settings, a technical advisor will often be involved as well. The technical advisor normally will have more familiarity with the field of the invention than the prosecutor but probably less than people actively working in the field.

72. See John M. Golden, *Construing Patent Claims According to Their "Interpretive Community": A Call for an Attorney-Plus-Artisan Perspective*, 21 HARV. J.L. & TECH. 321, 369-70 (2008).

73. See Menell et al., *supra* note 65, at 720.

74. See 35 U.S.C. §§ 102, 103, 112 (2012).

“Office Actions” finding the invention unpatentable either because the disclosure is insufficient or, more commonly, because it is too close to the prior art.<sup>75</sup> The patent prosecutor will then provide a “Response,” which explains why the invention is a sufficient advance over the prior art to warrant a patent.<sup>76</sup> The prosecutor frequently also will amend the claims to narrow or clarify them in a way designed to distinguish the prior art identified by the examiner.<sup>77</sup> Normally, the specification is not amended after the filing of the patent application because, if it is, any activities between when the patent application was filed and the amendment was made, including those by the applicant, can be used as prior art to show that the draft patent does not describe a sufficient enough advance.<sup>78</sup> All of these documents exchanged during patent prosecution—referred to as the “file-wrapper” or “prosecution history”—are made publicly available when the patent issues (now for free on the Patent Office’s website<sup>79</sup>) and are part of the patent’s public record.

## B. *Interpreting Patent Claims*

### 1. The Importance of Claim Construction

Patent claims, like the words of other legal documents, require significant interpretation to perform their legal functions.<sup>80</sup> Indeed, interpretation of claim language may be even more crucial than interpretation of language in other legal documents because of the difficulties of translating complex technical concepts into brief, legal shorthand, as well as the patentee’s incentives to use the broadest, vaguest, and most ambiguous language possible.<sup>81</sup>

Claim construction is required before a court can resolve the key issues in any patent case, including whether a competitor’s product falls within the patentee’s exclusive rights (“infringes” in patent terminology)<sup>82</sup> or whether the patent is “invalid” for failing to be sufficiently novel and nonobvious to advance over the prior art<sup>83</sup> or provide adequate disclosure to satisfy the *quid*

---

75. See KIEFF ET AL., *supra* note 62, at 105.

76. See *id.* at 106.

77. *Id.*

78. See *id.*

79. Patent Application Information Retrieval, U.S. PAT. & TRADEMARK OFF., <http://portal.uspto.gov/pair/PublicPair> (last visited Nov. 10, 2013).

80. William R. Hubbard, *Efficient Definition and Communication of Patent Rights: The Importance of Ex Post Delineation*, 25 SANTA CLARA COMPUTER & HIGH TECH. L.J. 327, 336 (2009).

81. *Autogiro Co. of Am. v. United States*, 384 F.2d 391, 396-97 (Ct. Cl. 1967).

82. *Cybor Corp. v. FAS Techs., Inc.*, 138 F.3d 1448, 1454 (Fed. Cir. 1998) (en banc).

83. *Key Pharms. v. Hercon Labs. Corp.*, 161 F.3d 709, 714 (Fed. Cir. 1998).

*pro quo* for the exclusive rights.<sup>84</sup> Claim construction also is a threshold step to virtually every other patent issue.<sup>85</sup>

Claim construction can be case dispositive, such as when the parties' real dispute is not how the competitor's product operates or what existed in the field before the invention, but rather whether the patent claim reaches the competitor's product or extends beyond the prior art.<sup>86</sup> Even if not completely dispositive, claim construction tends to be case determinative by limiting the issues for summary judgment or trial, increasing settlement prospects through a narrower range of possible case evaluations, and strengthening the position of one party at the expense of the other.

Claims also must be construed by a variety of actors outside of litigation: patent examiners deciding whether to grant a patent; competitors deciding whether to proceed with a product, seek a license, or design around the patent; subsequent researchers determining whether a specific improvement or research trail remains open; patentees determining whether to make a patent assertion or bring an infringement action; and investors investing in the patentee or a potential infringer.<sup>87</sup> The legal rules for claim construction developed in litigation, at least in theory, will affect these actors' conclusions about claim scope and their resulting activities.

## 2. Claim Construction Rules

The Constitution, Patent Act, and Supreme Court precedent provide little, if any, guidance as to how to interpret patent claims.<sup>88</sup> Rather, the task of

---

84. *Atl. Research Mktg. Sys., Inc. v. Troy*, 659 F.3d 1345, 1354 (Fed. Cir. 2011) (written description); *Chiron Corp. v. Genentech, Inc.*, 363 F.3d 1247, 1254 (Fed. Cir. 2004) (enablement); *N. Telecom Ltd. v. Samsung Elecs. Co.*, 215 F.3d 1281, 1286-87 (Fed. Cir. 2000) (best mode).

85. *See, e.g., Bancorp Servs., L.L.C. v. Sun Life Assurance Co. of Can. (U.S.)*, 687 F.3d 1266, 1273-74 (Fed. Cir. 2012) (statutory subject matter); *AIA Eng'g Ltd. v. Magotteaux Int'l S/A*, 657 F.3d 1264, 1271 (Fed. Cir. 2011) (impermissible claim enlargement during reissue); *Therasense, Inc. v. Becton, Dickinson & Co.*, 649 F.3d 1276, 1291-92 (Fed. Cir. 2011) (en banc) (but-for materiality for inequitable conduct); *iLOR, LLC v. Google, Inc.*, 631 F.3d 1372, 1378 (Fed. Cir. 2011) (exceptional case and attorney's fees); *Cohesive Techs., Inc. v. Waters Corp.*, 543 F.3d 1351, 1374 (Fed. Cir. 2008) (willful infringement); *Trovan, Ltd. v. Sokymat SA*, 299 F.3d 1292, 1302 (Fed. Cir. 2002) (inventorship); *Exxon Research & Eng'g Co. v. United States*, 265 F.3d 1371, 1375 (Fed. Cir. 2001) (indefiniteness); *Eli Lilly & Co. v. Barr Labs., Inc.*, 251 F.3d 955, 968 (Fed. Cir. 2001) (double patenting); *Raytheon Co. v. Roper Corp.*, 724 F.2d 951, 956 (Fed. Cir. 1983) (inoperability).

86. *See Cotropia, supra* note 34, at 67; *see, e.g., Honeywell Int'l, Inc. v. Universal Avionics Sys. Corp.*, 493 F.3d 1358, 1366 (Fed. Cir. 2007) (infringement verdict challenged just on claim construction); *Ventana Med. Sys., Inc. v. Biogenex Labs., Inc.*, 473 F.3d 1173, 1177 (Fed. Cir. 2006) (district court claim construction led to stipulated judgment of non-infringement).

87. *Wagner & Petherbridge, supra* note 14, at 125; *see Moore, supra* note 16, at 5; Kelly Casey Mullally, *Patent Hermeneutics: Form & Substance in Claim Construction*, 59 FLA. L. REV. 333, 336 (2007).

88. *See Cotropia, supra* note 34, at 71.



defining an approach to interpreting patent claims has been left to the Federal Circuit, which has exclusive appellate jurisdiction in patent cases. The Federal Circuit summarized its precedent in the 2005 *en banc* decision in *Phillips v. AWH Corporation*, which has been widely criticized for failing to clarify claim construction standards and adopting an “anything goes” approach.<sup>89</sup>

Under this approach, claim terms are given their “ordinary and customary meaning” to a reasonable specialist in the technological field of the invention—referred to as the “person having ordinary skill in the art” or “PHOSITA” in patent terminology—because inventors are typically persons skilled in the field of the invention and patents are addressed to and intended to be read by other skilled people in the field.<sup>90</sup> But the Federal Circuit emphasized that this “ordinary and customary meaning” to a skilled person was not necessarily the skilled person’s background, general understanding of the term because the skilled person “is deemed to read the claim term . . . in the context of the entire patent, including the specification.”<sup>91</sup> *Phillips* identified four possible sources for interpreting patent claims.

*First*, the claim language itself is crucial to claim construction. Like any interpretive task, claim construction begins with the actual words being interpreted. In some cases, it also ends there, because a skilled person would share the “widely accepted meaning of commonly understood words” that is “readily apparent even to lay judges.”<sup>92</sup> But these will be unusual cases because the meaning to a skilled person “is often not immediately apparent” in cases that result in litigation.<sup>93</sup> Moreover, because a judge is not herself a skilled person in the field, the judge cannot even be confident that a skilled person would actually understand what appears to be a “commonly understood word” consistent with the “widely accepted meaning.”<sup>94</sup> For example, would a skilled person understand the term “body” in a retractable needle patent to be used consistent with its ordinary English meaning, or to be used in a specialized way in the field of needle technology?<sup>95</sup>

Beyond the actual words being interpreted, the remainder of the claim at issue, and other claims in the patent, are useful in claim construction because they provide relevant context under familiar linguistic canons used to inter-

---

89. *Phillips v. AWH Corp.*, 415 F.3d 1303 (Fed. Cir. 2005) (*en banc*); *e.g.*, Osenga, *supra* note 15, at 72, 80, 82; Wagner & Petherbridge, *supra* note 14, at 130.

90. *Phillips*, 415 F.3d at 1313.

91. *See id.*

92. *Id.* at 1314.

93. *Id.*

94. *Id.*

95. *E.g.*, *Retractable Techs., Inc. v. Becton, Dickinson & Co.*, 653 F.3d 1296, 1312 (Fed. Cir. 2011) (Rader, J., dissenting) (assuming “body” had ordinary English meaning without considering whether any technical meaning existed in field of invention).

pret any legal document or written communication.<sup>96</sup> For example, courts should adopt certain presumptions: that different words or phrases have different meanings; that terms are used consistently in different claims; and that the inclusion of additional requirements in one claim means that those requirements are not present in other claims where they are not expressly recited (“claim differentiation” in patent terminology).<sup>97</sup>

*Second*, courts should read claim terms in light of the written description of the invention in the specification, which “is always highly relevant to the claim construction analysis,” is usually “dispositive,” and “is the single best guide to the meaning of a disputed term.”<sup>98</sup> The Federal Circuit cited the specification in construing over 80% of terms in recent years.<sup>99</sup> The exact role of the specification in claim construction remains a contentious issue, despite the strong language in *Phillips*.<sup>100</sup>

*Third*, *Phillips* held that a court should consider a patent’s prosecution history if it is in evidence.<sup>101</sup> Yet the prosecution history was only referenced for 46.9% of terms that the Federal Circuit construed in the years before *Phillips* and 37.1% in the years since.<sup>102</sup> The decrease in usage of the prosecution history is consistent with the view in *Phillips* that the prosecution history often lacks clarity and is less useful for claim construction because it “represents an ongoing negotiation between the [Patent Office] and the applicant.”<sup>103</sup> Under the doctrine of “prosecution disclaimer,” the prosecution history can narrow the meaning the claim term would otherwise have when the patentee made “clear and unmistakable” statements during prosecution to avoid the prior art and obtain the patent.<sup>104</sup> *Phillips* described an additional,

---

96. 5A DONALD S. CHISUM, CHISUM ON PATENTS § 18.03[2][B][iii] (2013), available at LexisNexis; see generally ANTONIN SCALIA & BRYAN A. GARNER, READING LAW: THE INTERPRETATION OF LEGAL TEXTS (2012).

97. *Phillips*, 415 F.3d at 1314-15; CHISUM, *supra* note 96, § 18.03[2][b][iii][A].

98. *Phillips*, 415 F.3d at 1315 (quoting *Vitronics Corp. v. Conceptronic, Inc.*, 90 F.3d 1576, 1582 (Fed. Cir. 1996)). The specification sometimes has been compared to statutory legislative history, even though the claims are statutorily part of the specification and therefore part of the same “fully integrated written instrument.” *Id.* (quoting *Markman v. Westview Instruments, Inc.*, 52 F.3d 967 (Fed. Cir. 1995), *aff’d*, 517 U.S. 370 (1996)). The better analogy is to other parts of the same statute, which, under the “whole-text canon” in statutory interpretation, are important context because the interpretation of a term must be “compatible with the use of the same word or phrase elsewhere in the statute.” SCALIA & GARNER, *supra* note 96, at 167-70.

99. J. Jonas Anderson & Peter S. Menell, *Informal Deference: An Historical, Empirical, and Normative Analysis of Patent Claim Construction*, 108 Nw. U. L. REV. 1, 44 (2013).

100. See *infra* Part II.A.

101. *Phillips*, 415 F.3d at 1317 (citing *Markman*, 52 F.3d at 980).

102. Anderson & Menell, *supra* note 99, at 44.

103. *Phillips*, 415 F.3d at 1317; Anderson & Menell, *supra* note 99, at 45.

104. *Omega Eng’g, Inc. v. Raytek Corp.*, 334 F.3d 1314, 1323-26 (Fed. Cir. 2003).

more general use for the prosecution history: to show how the inventor understood and used a claim term.<sup>105</sup>

*Fourth*, the court can consider evidence external to the patent and prosecution history, such as dictionaries, treatises, prior art, and expert testimony, to provide the background information about the technical field and the terminology in that field or to show that a term has a particular established meaning in the field.<sup>106</sup> The Federal Circuit referenced extrinsic evidence in construing 33.2% of terms before *Phillips* and 26.3% since *Phillips*, with expert testimony referenced for 8.8-12.1% of terms.<sup>107</sup> The Federal Circuit's decreased usage of extrinsic evidence after *Phillips* is consistent with the warning in *Phillips* that extrinsic evidence, especially expert testimony, can be unreliable and is significantly less important than the intrinsic evidence of the claims, specification, and prosecution history.<sup>108</sup> *Phillips* thus rejected an approach to claim construction that started with an "ordinary meaning" of a claim term derived from dictionaries, treatises, or other extrinsic sources and only then looked to the specification for the limited purpose of finding an express definition, disclaimer, or other rebuttal of this "ordinary meaning."<sup>109</sup>

*Phillips* cautioned that expert testimony and other extrinsic evidence is created, or selected from a wide range of possible sources of marginal relevance, for purposes of litigation.<sup>110</sup> Moreover, extrinsic sources may not be written by or for people with the precise skill level or in the precise field of the patent, nor are experts always at the precise skill level in the precise field of the patent.<sup>111</sup> Extrinsic evidence also may not be consistent with the way that language is used in the public record of the patent and prosecution history.<sup>112</sup>

## II. THE FEDERAL CIRCUIT'S CLAIM CONSTRUCTION SPLIT

### A. A Division Over General or Specific Meaning

Commentators have long recognized a methodological split in the Federal Circuit's claim construction jurisprudence.<sup>113</sup> Even Federal Circuit judges have acknowledged a "fundamental split" as to whether claims are

---

105. *Phillips*, 415 F.3d at 1317; *see also, e.g.*, *St. Clair Intell. Prop. Consultants, Inc. v. Canon Inc.*, 412 F. App'x 270, 276-77 (Fed. Cir. 2011); *id.* at 280 (Moore, J., dissenting) (relying on how term was used during prosecution even though "St. Clair did not clearly disavow claim scope").

106. *Id.* at 1317-18.

107. Anderson & Menell, *supra* note 99, at 45-47.

108. *Phillips*, 415 F.3d at 1317-18.

109. *Id.* at 1320.

110. *Id.* at 1318.

111. *Id.*

112. *Id.* at 1318-19.

113. *See, e.g.*, Nard, *supra* note 31 (describing split in 2000).

generally given their “plain and ordinary meaning” or whether they are “redefine[d] . . . to match . . . the scope of the invention as disclosed in the specification.”<sup>114</sup> The Federal Circuit granted *en banc* review in *Phillips* to resolve this split.<sup>115</sup> Unfortunately, *Phillips* attempted to reconcile all prior cases, rather than overruling one of the competing lines, and thus can be read as supporting either side of the methodological split.<sup>116</sup> A recent empirical study confirms that the Federal Circuit’s precedent is as divided today as before *Phillips*.<sup>117</sup>

The Federal Circuit’s claim construction split has been described in a variety of ways: whether intrinsic or extrinsic evidence provides greater certainty and predictability,<sup>118</sup> whether the claims should be limited to the invention disclosed in the specification,<sup>119</sup> whether the dictionary or the specification is the best place to identify the “ordinary and customary meaning” of a term,<sup>120</sup> whether claim construction should be formalistic or holistic,<sup>121</sup> and whether the canon that claims must be read in light of the specification should trump the canon against importing limitations from the specification into the claims or vice versa.<sup>122</sup>

Though largely unrecognized in the scholarship,<sup>123</sup> the core question uniting all of these various descriptions is whether claim terms should be given the general meaning they normally possess in the field of the invention or the specific meaning with which they are used in the patent itself.<sup>124</sup> In other words, the claim construction debate is over the proper context for

114. *Thorner v. Sony Computer Entm’t Am. LLC*, 669 F.3d 1362, 1365-66 (Fed. Cir. 2012); *Retractable Techs., Inc. v. Becton, Dickinson & Co.*, 659 F.3d 1369, 1371 (Fed. Cir. 2011) (Moore, J. dissenting from the denial of the petition for rehearing *en banc*).

115. *Phillips*, 415 F.3d at 1312.

116. *See Wagner & Petherbridge*, *supra* note 14, at 130; *Compare On Demand Machine Corp. v. Ingram Indus., Inc.*, 442 F.3d 1331, 1337-38 (Fed. Cir. 2006) (contextual) *with Retractable Techs.*, 659 F.3d at 1371-72 (Moore, J., dissenting from the denial of the petition for rehearing *en banc*) (ordinary meaning).

117. *Wagner & Petherbridge*, *supra* note 14.

118. *See Nard*, *supra* note 31, at 7-10, 47.

119. *See Cotropia*, *supra* note 34, at 105-15.

120. *See Osenga*, *supra* note 15, at 77.

121. *See Wagner & Petherbridge*, *supra* note 17, at 1133-34.

122. Christopher A. Cotropia, *What is the “Invention”?*, 53 WM. & MARY L. REV. 1855, 1906 (2012).

123. *But see Cotropia*, *supra* note 34, at 114 (noting that claim-centric methodology “moves the claim term’s meaning from the context of the patent to the abstract”); *Wagner & Petherbridge*, *supra* note 17, at 1134 (referencing a dichotomy between “the abstracted ‘ordinary meaning’ of a term” and “a more localized understanding”).

124. Professors Chiang and Solum have recently suggested that the claim construction split does not result from uncertainty about linguistic meaning but rather diverging policy goals. Tun-Jen Chiang & Lawrence B. Solum, *The Interpretation-Construction Distinction in Patent Law*, 123 YALE L.J. (forthcoming 2013), available at [http://papers.ssrn.com/so13/papers.cfm?abstract\\_id=2234193](http://papers.ssrn.com/so13/papers.cfm?abstract_id=2234193). Chiang and Solum overlook the linguistic disagreement over whether the proper context for the claim construction is general knowledge in the field, the patent itself, or some combination of the two. *Id.* at 18-19, 34.

interpreting patent claims: the background knowledge and understanding of skilled people in the field,<sup>125</sup> the description of the invention in the specification,<sup>126</sup> or some combination of both<sup>127</sup>?

One line of cases and scholarship increasingly favors limiting the context for claim construction to the general meaning to a skilled person in the field of the invention. Under this view, a judge should consult the specification only in very limited circumstances.<sup>128</sup> Rather, claim terms “must be given” their ordinary meaning to skilled person in the field at the time of the invention,<sup>129</sup> or at least they bear a “heavy presumption” in favor of such meaning,<sup>130</sup> with recent cases emphasizing that this is a “plain,” or abstract, meaning.<sup>131</sup> Before *Phillips* rejected extrinsic evidence as the starting point for claim construction,<sup>132</sup> the ordinary meaning was derived from dictionaries, treatises, or other similar extrinsic sources.<sup>133</sup> Since *Phillips*, this line generally starts just with the judge’s own understanding, without any effort to corroborate this understanding with contemporaneous sources in the field of the invention.<sup>134</sup> The judge then only consults the specification to determine whether the specification satisfies the “exacting” standard for two “quite narrow” exceptions to ordinary meaning: where the patentee “clearly set forth” an express definition or used “expressions of manifest exclusion or

125. *Phillips v. AWH Corp.*, 415 F.3d 1303, 1313 (Fed. Cir. 2005) (en banc) (quoting *Multiform Desiccants, Inc. v. Medzam, Ltd.*, 133 F.3d 1473, 1477 (Fed. Cir. 1998)).

126. *Vitronics Corp. v. Conceptronic, Inc.*, 90 F.3d 1576, 1583 (Fed. Cir. 1996).

127. *Nard*, *supra* note 31, at 48-49.

128. *E.g.*, *Thorner v. Sony Computer Ent’mt Am. LLC*, 669 F.3d 1362, 1365-67 (Fed. Cir. 2012); *Wagner & Petherbridge*, *supra* note 14, at 143-44.

129. *Thorner*, 669 F.3d at 1367; *see also, e.g.*, *Interdigital Commc’ns, LLC v. Int’l Trade Comm’n*, 690 F.3d 1318, 1324 (Fed. Cir. 2012); *Retractable Techs., Inc. v. Becton, Dickinson & Co.*, 659 F.3d 1369, 1371 (Fed. Cir. 2011) (Moore, J. dissenting from the denial of the petition for rehearing en banc); *Retractable Techs., Inc. v. Becton, Dickinson & Co.*, 653 F.3d 1296, 1312 (Fed. Cir. 2011) (Rader, J. dissenting).

130. *Johnson Worldwide Assocs., Inc. v. Zebco Corp.*, 175 F.3d 985, 989 (Fed. Cir. 1999); *see also, e.g.*, *Tex. Digital Sys., Inc. v. Telegenix, Inc.*, 308 F.3d 1193, 1202-05 (Fed. Cir. 2002).

131. *E.g.*, *Thorner* 669 F.3d at 1365.

132. *See supra* Part I.B.2.

133. *Tex. Digital*, 308 F.3d at 1202-05.

134. *E.g.*, *In re Rambus, Inc.*, 694 F.3d 42 (Fed. Cir. 2012), *reh’g denied* (2012) (“memory device” in computer technology); *Thorner*, 669 F.3d at 1367 (“attached” in video game console design); *Retractable*, 653 F.3d at 1312 (Rader, J., dissenting) (“body” in medical syringes); *St. Clair Intell. Prop. Consultants, Inc. v. Canon Inc.*, 412 F. App’x 270, 278 (Fed. Cir. 2011) (Moore, J., dissenting) (“plurality of different data formats” in camera technology); *Arlington Indus., Inc. v. Bridgeport Fittings, Inc.*, 632 F.3d 1246, 1253 (Fed. Cir. 2011) (“spring metal adaptor” in electrical connectors); *Decisioning.com, Inc. v. Federated Dep’t Stores, Inc.*, 527 F.3d 1300, 1318 (Fed. Cir. 2008) (Linn, J., dissenting) (“remote interface” in financial data processing system); *Medegen MMS, Inc. v. ICU Med., Inc.*, 317 Fed. Appx. 982, 986-87 (Fed. Cir. 2008) (“plug” in intravenous medical devices); *Acumed LLC v. Stryker Corp.*, 483 F.3d 800, 805 (Fed. Cir. 2007) (“curved shank” in orthopedic devices).

restriction” that clearly and unmistakably disclaimed claim scope.<sup>135</sup> Although earlier “ordinary meaning” cases also consulted the specification when multiple “ordinary” meanings were found in extrinsic sources,<sup>136</sup> recent opinions now suggest that the court should adopt the broadest of the possible “ordinary” meanings.<sup>137</sup>

Tying claim construction to the general meaning in the field of the invention is said to promote predictability and public notice. For example, Professors Wagner and Petherbridge contend that “embrac[ing] the commonly-understood meaning of words [in the field], and plac[ing] the burden on the patent applicant to clearly explain any deviations” will ensure that “the meaning of claim language is readily apparent to patent readers.”<sup>138</sup> Predictability of patent rights, like any property right,<sup>139</sup> is crucial to permit planning<sup>140</sup> and to avoid inefficiencies from unintentional infringement that could have been cheaply avoided, omission of productive activities unprotected by the patent, payment of unnecessary royalties, and expensive litigation and missed settlement opportunities.<sup>141</sup>

A second line of cases and scholarship increasingly limits claim construction to the specific meaning in the context of the patent, regardless of how a term is otherwise used in the field of invention. Traditionally, this line has treated the specification as a dictionary that can define claim terms either expressly or implicitly.<sup>142</sup> Thus, “the specification is always highly relevant to the claim construction analysis. Usually, it is dispositive; it is the single best guide to the meaning of a disputed term.”<sup>143</sup> Under this approach, extrinsic evidence is rarely consulted and, if it is, cannot justify a broader construction than can be derived just from the intrinsic evidence.<sup>144</sup> Recent opinions and scholarship in this line have gone beyond just using the specification as a dictionary and now contend that the interpreter should first read the specification to determine the patentee’s “actual invention” and then tai-

---

135. *Thormer*, 669 F.3d at 1365-66; *Retractable*, 659 F.3d at 1371 (Moore, J. dissenting from the denial of the petition for rehearing en banc).

136. *E.g.*, *Tex. Digital*, 308 F.3d at 1203-04.

137. *E.g.*, *Thormer*, 669 F.3d at 1367.

138. Wagner & Petherbridge, *supra* note 14, at 144; *see also* Wagner & Petherbridge, *supra* note 17, at 1142 (explaining that “in the long run” this approach will yield “more predictable” results”).

139. R. H. Coase, *The Problem of Social Cost*, 3 J.L. & ECON. 1, 19 (1960); *see also* Wagner & Petherbridge, *supra* note 14, at 143 (citing Coase to support reliance on a term’s general meaning in field).

140. *See* VERMEULE, *supra* note 29, at 79; *see also* *Festo Corp. v. Shoketsu Kinzoku Kogyo Kabuskiki Co.*, 535 U.S. 722, 730-31 (2002).

141. Jeffrey A. Lefstin, *Claim Construction, Appeal, and the Predictability of Interpretive Regimes*, 61 U. MIAMI L. REV. 1033, 1041-42 (2007).

142. *E.g.*, *Vitronics Corp. v. Conceptronic, Inc.*, 90 F.3d 1576, 1582 (Fed. Cir. 1996).

143. *Id.*

144. *Id.* at 1583; *Nystrom v. Trex Co.*, 424 F.3d 1136, 1144-45 (Fed. Cir. 2005).

lor the claim construction as necessary to capture this “actual invention,” even if the court must disregard the claim language.<sup>145</sup>

Limiting claim construction to the specific context of the patent is justified as insuring that the patentee’s exclusive rights are proportional to what the patentee actually invented and contributed to the field.<sup>146</sup> Proportionality, like predictability, is reasonably grounded in the classic economic justifications of the patent system, as it ensures that the patentee incurred fixed research and development costs for a product that justify monopoly rents, and it mitigates social costs by leaving room for others to design around the patent and make improvements.<sup>147</sup>

*Phillips* sought a middle ground between general and specific meaning by embracing a skilled person’s perspective but concluding that the skilled person would interpret the claims terms in the context of the entire patent, not just using her background knowledge and understanding.<sup>148</sup> *Phillips* favored a vague standard for determining when the context of the patent was sufficient to overcome the general meaning to a skilled person, concluding that this normally would become clear “upon reading the specification” and was best resolved on a patent-by-patent basis.<sup>149</sup> The increasing tendency of the competing lines of authority to embrace either exclusively general or exclusively specific meaning reflects widespread dissatisfaction with the case-by-case adjudication endorsed by *Phillips*.

### B. The Importance of General or Specific Meaning

If patents always used terminology consistent with its general meaning in the field of the invention, the precedential split over general or specific meaning would be of minimal significance. However, “the nature of language makes it impossible to capture the essence of a thing in a patent appli-

---

145. *E.g.*, *Arlington Indus., Inc. v. Bridgeport Fittings, Inc.*, 632 F.3d 1246, 1258 (Fed. Cir. 2011) (Lourie, J., concurring in part and dissenting in part); *see also* *Retractable Techs., Inc. v. Becton, Dickinson & Co.*, 659 F.3d 1369, 1371 (Fed. Cir. 2011) (Moore, J. dissenting from the denial of the petition for rehearing en banc) (criticizing this approach); *see also, e.g.*, *Interdigital Commc’ns, LLC v. Int’l Trade Comm’n*, 690 F.3d 1318, 1335 (Fed. Cir. 2012) (Newman, J., dissenting); *Retractable Techs., Inc. v. Becton, Dickinson & Co.*, 653 F.3d 1296, 1305 (Fed. Cir. 2011); *id.* at 1311 (Plager, J., concurring); *Burk & Lemley, supra* note 20, at 1797; *Cotropia, supra* note 122 at 1907; *Liivak, supra* note 28, at 44.

146. *Retractable*, 653 F.3d at 1311 (Plager, J., concurring); *see* *Liivak, supra* note 28, at 37-44.

147. The classic utilitarian justification for the patent system is that inventions are expensive to produce but cheap to copy and without exclusive rights, and the accompanying monopoly rents, the patentee would not be able to recoup its fixed costs because competition would drive prices to marginal cost. *See* WILLIAM M. LANDES & RICHARD A. POSNER, *THE ECONOMIC STRUCTURE OF INTELLECTUAL PROPERTY LAW* 294 (2003); Dan L. Burk & Mark A. Lemley, *Policy Levers in Patent Law*, 89 VA. L. REV. 1575, 1580, 1597 (2003).

148. *Phillips v. AWH Corp.*, 415 F.3d 1303, 1313 (Fed. Cir. 2005) (en banc).

149. *Id.* at 1323-24.

ation”<sup>150</sup> and “the patent by its nature describes something novel.”<sup>151</sup> Often “words do not exist to describe” the novel invention or the “conversion of machine to words allows for idea gaps which cannot be satisfactorily filled” with existing terminology.<sup>152</sup> Patentees have to use new words,<sup>153</sup> existing words in new or unusual ways,<sup>154</sup> existing words in new or unusual combinations,<sup>155</sup> specific words in more general ways,<sup>156</sup> or general words in more specific ways.<sup>157</sup> Moreover, claims are drafted by patent prosecutors who may not be versed in the terminology in the field or may inadvertently use words incorrectly or otherwise differently from people in the field of invention.<sup>158</sup> Finally, patent prosecutors often use patentese that resembles technical terminology but has acquired a specific and established meaning in the patent prosecution context.<sup>159</sup> For these reasons, the choice between the general meaning a term normally bears in the technical field and the specific meaning with which it is used in the patent will often result in different claim constructions and therefore claim scope.

Empirical studies confirm the significance of the methodological split. The Federal Circuit’s construction depends on the judges’ preferred methodological approaches and, consequently, the Federal Circuit’s claim construc-

---

150. *Festo Corp. v. Shoketsu Kinzoku Kogyo Kabuskiki Co.*, 535 U.S. 722, 731 (2002).

151. *Phillips*, 415 F.3d at 1322.

152. *Autogiro Co. of Am. v. United States*, 384 F.2d 391, 397 (Ct. Cl. 1967); *see also* Burk & Lemley, *supra* note 20, at 1752; Amanda C. Schierz, *Monitoring Knowledge: A text-based approach*, 13 *TERMINOLOGY* 125, 125 (2007) (“Key developments in science and engineering are usually signalled by the introduction of new terms, and the exclusion of established ones. . . .”).

153. *See* Lear Siegler, Inc. v. Aeroquip Corp., 733 F.2d 881, 888-89 (Fed. Cir. 1984); *Autogiro*, 384 F.2d at 397; *see also*, Bancorp Servs., L.L.C. v. Hartford Life Ins. Co., 359 F.3d 1367, 1372 (Fed. Cir. 2004) (noting that “surrender value protected investment credits” was not a term known in the field). *But see* Schierz, *supra* note 152, at 147.

154. *See*, *Phillips*, 415 F.3d at 1322; *see also, e.g.*, ArcelorMittal Fr. v. AK Steel Corp., 700 F.3d 1314, 1320-21 (Fed. Cir. 2012) (holding that the ordinary meaning in industry was “clear,” that term “hot-rolled steel sheet” “refers to steel sheet that has not been cold-rolled,” but patent used the term to refer to steel sheet that had been hot-rolled during production even if it had also been cold-rolled).

155. *E.g.*, Osenga, *supra* note 15, at 67 (giving example of “perimeter surface”).

156. *E.g.*, *Rajah Auto Supply Co. v. Belvidere Screw & Mach. Co.*, 275 F. 761, 763-64 (7th Cir. 1921) (holding that term “soft-metal” was normally used to refer to a specific, defined group of metals, but patentee implicitly used term more generally in the patent to refer to “a material which would upset, or was adaptable to be upset, when under pressure such as is applied to a spark plug”).

157. *E.g.*, *Decisioning.com, Inc. v. Federated Dep’t Stores, Inc.*, 527 F.3d 1300, 1308-11 (Fed. Cir. 2008) (noting that broad claim term “remote interface” generally could include consumer-owned personal computer but that patent used term more narrowly in way that excluded consumer-owned personal computer).

158. *E.g.*, *Honeywell Int’l, Inc. v. Universal Avionics Sys. Corp.*, 493 F.3d 1358, 1361 (Fed. Cir. 2007) (“[T]he patentees used the term ‘heading of the aircraft’ to refer to what would normally be referred to as the aircraft’s ‘bearing[.]’”); *see* Menell et al., *supra* note 65, at 719-20.

159. *See* Menell et al., *supra* note 65, at 720.



tion is related in a statistically significant way to the composition of the panel of judges that hears an appeal.<sup>160</sup> Likewise, “disputes over claim construction outcomes found in the jurisprudence are overwhelming the result of disagreements over the methodological approach,” with up to 95% of disputes among Federal Circuit judges and 75-82% of Federal Circuit reversals of district court claim constructions resulting from different choices between the two competing methodologies.<sup>161</sup> Thus, the Federal Circuit’s methodological split is directly responsible for most of the problems commentators identify in the Federal Circuit’s claim construction precedent—high reversal rates, unpredictability before litigation, uncertainty in litigation, appellate panel dependence, disincentives to settle, and increased litigation and costs.<sup>162</sup>

### C. *The Missing Question of Generalist Judges*

The claim construction debate largely overlooks the abilities and limitations of those who must implement claim construction: primarily generalist judges.<sup>163</sup> Although this type of “institutional blindness” pervades interpretive theory generally,<sup>164</sup> judges in other contexts have some measure of inherent competence to interpret legal documents that normally use ordinary English or common legal terminology.<sup>165</sup> By contrast, claim construction requires generalist judges—the non-specialized and normally non-technically trained district court judges and the specialized but generally non-technically

---

160. See Wagner & Petherbridge, *supra* note 17, at 1163-70.

161. *Id.* at 1143-44.

162. These problems often are incorrectly attributed to the Federal Circuit’s de novo standard of review for claim construction. See Greg Reilly, *Improviently Granted: Why the En Banc Federal Circuit Chose the Wrong Claim Construction Issue*, 80 U. CHI. L. REV. DIALOGUE 43 (2013), available at [https://lawreview.uchicago.edu/sites/lawreview.uchicago.edu/files/uploads/Dialogue/Reilly\\_Online\\_Final.pdf](https://lawreview.uchicago.edu/sites/lawreview.uchicago.edu/files/uploads/Dialogue/Reilly_Online_Final.pdf).

163. See Tun-Jen Chiang, *Forcing Patentee Claims 25-27*, 41-43 (2012) (unpublished manuscript), available at [http://papers.ssrn.com/sol3/papers.cfm?abstract\\_id=2130961](http://papers.ssrn.com/sol3/papers.cfm?abstract_id=2130961) (criticizing other approaches on institutional grounds but failing to consider institutional capacities for his own proposal to give “claim text primary weight”); Mullally, *supra* note 87, at 368 (criticizing “formalism” in claim construction in part as giving too much discretion to judges). *But see* Wagner & Petherbridge, *supra* note 14, at 144-145.

164. See VERMEULE, *supra* note 29, at 9, 15-16.

165. The claim is that patents are more likely to present unfamiliar terminology to generalist judges. Of course, statutes and contracts sometimes use technical terminology with specialized meanings in specific fields. See, e.g., *Chevron U.S.A., Inc. v. Natural Res. Def. Council, Inc.*, 467 U.S. 837 (1984) (statutory interpretation accounting for specialized terminology by providing for deference to the interpretation of an administrative agency charged with implementing a specialized statute); Ronald J. Gilson et al., *Contract & Innovation: The Limited Role of Generalist Courts in the Evolution of Novel Contractual Forms*, 88 N.Y.U. L. REV. 170, 214-15 (2013) (suggesting similar deference to contractual interpretations developed by trade associations and other “contextualizing regimes”). By contrast, the Federal Circuit has declined to defer to Patent Office claim constructions. See *SRAM Corp. v. AD-II Eng’g, Inc.*, 465 F.3d 1351, 1359 (Fed. Cir. 2006).

trained Federal Circuit judges<sup>166</sup>—to interpret a mix of technical terminology, patentese, and ordinary English. The capacities and limitations of these judges are thus particularly salient for claim construction.<sup>167</sup>

### 1. Interpretive Choice and Judicial Capacities

In the analogous context of constitutional and statutory interpretation, Adrian Vermeule has provided the most sustained consideration of the relationship between judicial capacities and interpretive approaches, giving the issue book-length treatment.<sup>168</sup> Vermeule's detailed analysis of judicial capacities and interpretation thus is a useful place to start in considering how to craft a patent claim interpretation approach best suited to the capacities of generalist judges.

Vermeule suggests that idealized theories about what interpretive approach will best promote certain interpretive values (*e.g.*, predictability or proportionality in claim construction) are necessarily incomplete without considering whether the relevant institution (*e.g.*, generalist judges) can successfully implement the interpretive approach at a reasonable cost.<sup>169</sup> Vermeule calls this evaluation of the fit between interpretive approach and judicial capacities “interpretive choice.” According to Vermeule, interpretive choice must first consider of the relative rate of error and the relative costs of errors of the competing approaches.<sup>170</sup> These errors could result from a well-motivated judge who lacks information, has limited ability to process information, or is vulnerable to cognitive biases, as well as from an ill-motivated judge who is not sufficiently constrained to prevent intentional errors.<sup>171</sup> A difficulty with Vermeule's approach is that an “error” can only be defined in relation to some concept of a “correct” interpretation and competing interpretive approaches often differ on what constitutes a “correct” interpretation.

Vermeule's concern about disagreement over what constitutes a “correct” interpretation is borne out in patent claim construction. The various sides in the claim construction debate disagree as to whether a “correct”

---

166. Claim construction is conducted in the first instance by district judges, with wide ranging past experiences and dockets. Although the Federal Circuit is a specialized court, its docket also ranges far wider than patent cases, and only four of its fifteen current judges have any technical background. See *Court Jurisdiction*, U.S. CT. OF APPEALS FOR FED. CIRCUIT, <http://www.cafc.uscourts.gov/the-court/court-jurisdiction.html> (last visited Nov. 11, 2013). Even judges with technical backgrounds often will be confronted with patent cases in an unfamiliar technical field, making their technical background largely irrelevant.

167. David L. Schwartz, *Practice Makes Perfect? An Empirical Study of Claim Construction Reversal Rates in Patent Cases*, 107 MICH. L. REV. 223, 260 (2008) (noting problems created by fact that a judge cannot just use his or her own judgment to interpret claim language but rather must understand complex technology).

168. VERMEULE, *supra* note 29.

169. *Id.* at 16, 74, 77-78, 80-81.

170. *Id.* at 74, 77-78.

171. *Id.* at 78.

interpretation is the general meaning to a skilled person in the field, the specific meaning derived from the patent itself, or some combination of the two. For constitutional and statutory interpretation, Vermeule overcomes this difficulty by defining each approach's errors in reference to its own vision of a "correct" interpretation, and he explores whether each approach can succeed even on its own terms. Using a similar approach for claim construction can provide at least some traction on how well generalist judges can implement the competing approaches.<sup>172</sup>

Aside from error rates and error costs, Vermeule notes that interpretive choice also must account for the effect of a judge's errors on other actors and whether those actors will take steps to correct or avoid the mistakes or will instead exploit them, as well as the relative costs of decisions for courts, litigants, and those seeking legal advice regarding compliance *ex ante*.<sup>173</sup> Additional sources of information or steps in the methodological process may be too costly to justify any marginal impact they have on the quality of the resulting decision.<sup>174</sup>

The problem for interpretive choice, according to Vermeule, is that many of the relevant questions for constitutional and statutory interpretation are intractable empirical questions. At best, judges have limited information with which to answer these questions and—also, at best—limited cognitive abilities to process the information that is available.<sup>175</sup> Likewise, commentators in the patent context have been unable to prove whether or not the patent system promotes net social welfare or even whether consistently narrow or consistently broad patent scope is preferable.<sup>176</sup> In light of these difficulties, determining the economically optimal scope for any particular patent claim is a non-starter.<sup>177</sup> A variety of other difficult empirical questions lurk around claim construction, including whether predictability or proportionality of claim scope best promotes the economic justification for patents, how often patents use scientific terms consistent with their general meaning in the field, and whether reliance on the general meaning in the field or the disclosure of the patent makes claim scope more predictable.

Vermeule ultimately concludes that the limits of information and decision makers warrant a formalistic approach to statutory and constitutional interpretation where judges "sharply limit their interpretive ambitions, in part by limiting themselves to a small set of interpretive sources and a restricted range of relatively wooden decision-rules."<sup>178</sup> He thus concludes that

---

172. See *id.* at 80-81.

173. *Id.* at 74, 78-79; see also *id.* at 167.

174. See *id.* at 156.

175. See *id.* at 3-4.

176. See, e.g., LANDES & POSNER, *supra* note 147, at 310, 324-25.

177. Chiang, *supra* note 163, at 25.

178. See VERMEULE, *supra* note 29, at 4.

“judges should stick close to the surface-level or literal meaning.”<sup>179</sup> Parts III and IV *infra* similarly conclude that a limited and formalistic approach to patent claim construction is best suited to the abilities of generalist judges. However, these sections explain that, in the specific context of claim construction, this approach would lead to an interpretation dependent on the context provided by the patent specification and prosecution history, rather than the “ordinary” or “plain” meaning that Vermeule appears to endorse for constitutional and statutory interpretation.<sup>180</sup>

## 2. Institutional Choice or Interpretive Choice?

If an interpretive approach is not well suited to the interpreter, the choice is to either change the interpretive approach or change the interpreter. The second alternative, which can be called “institutional choice,” has received significant attention in the claim construction scholarship.<sup>181</sup> Although a full analysis of alternative institutional arrangements is beyond the scope of this Article, a brief summary shows significant shortcomings with institutional alternatives to claim construction by generalist judges.

One category of claim construction proposals focuses on changing the interpreter (*i.e.*, institutional choice) by altering specialization at different court levels. Proposals in this category would increase patent law specialization in the district court (to increase familiarity with the unique aspects of claim construction) and/or decrease specialization in the appellate courts (to decrease tunnel vision or increase variety in interpretive approaches).<sup>182</sup> However, existing empirical evidence demonstrates that experience with claim construction does not improve a district judge’s performance.<sup>183</sup> At best, increased specialization increases understanding of the legal rules and customs of patent drafting and claim construction, and perhaps of patentese, but it does not address the difficulties that arise from a non-technical judge interpreting the technical content of patents. Decreased specialization couples this same problem of non-technical judges with the additional problem of unfamiliarity with patent practice and patentese.

A second category of institutional proposals focuses on increasing the technical competence of decision makers, whether by creating patent courts with technically-trained judges or using technically-trained magistrates, special masters, or court-appointed experts.<sup>184</sup> Such proposals, if successfully implemented, could change the calculus for interpretive choice. But problems abound with these proposals. A person with a technical back-

---

179. *See id.*

180. *See id.* at 8 (noting that different variables and approaches may be appropriate for different interpretive contexts).

181. Schwartz, *supra* note 167, at 260-63 (summarizing scholarship).

182. *Id.* at 261-66 (summarizing scholarship).

183. *Id.* at 225-26.

184. *Id.* at 261.

ground (e.g., in biology) will be only marginally more capable of understanding technical content from another field (e.g., semiconductors) than a non-technically trained judge. Thus, any proposal for permanent technically-trained judges or magistrates is a non-starter, as it would require too great a range of judges with different technical backgrounds (as well as sufficient legal training, experience, and capabilities). Appointing special masters or experts on a case-by-case basis is more promising, though it raises challenges in identifying the precise field of the invention and finding a qualified master or expert in that field. There also is a risk of biases and inaccuracies if a master or expert is not from the precise field of the patent or had greater or lesser skill and knowledge than normal in the field at the time of the invention.<sup>185</sup> More importantly, unless the judge completely abdicates claim construction to the master or expert, she would still need to reach her own conclusion on claim construction, raising most of the same interpretive choice issues. Masters and court-appointed experts also often increase costs, as the parties have to present the issues to them in the first instance and then take objections or appeals to the district judge.

A final category of proposals would increase the role of the Patent Office in claim construction, even after the patent has issued.<sup>186</sup> Although this would increase competence with both technical content and patent terminology, it raises an entire body of literature about the performance, competence, and knowledge of patent examiners and the Patent Office.<sup>187</sup> The result may be to simply substitute one imperfect decision maker for another.

Ultimately, it is important to consider both institutional design and interpretive choice as ways to improve claim construction. Since new institutional arrangements for claim construction have failed to gain momentum, generalist judges are likely to continue interpreting patent claims for the time being. Tailoring a claim construction approach to their capabilities and limitations thus offers a way to improve claim construction in the near term.

### III. GENERALIST JUDGES AND GENERAL MEANING

In defending a claim construction approach focused on the general meaning the claim term ordinarily bears in the field of the invention, Professors Wagner and Petherbridge contend that this allows “the knowledge of technologists” to determine claim meaning.<sup>188</sup> Overlooked, however, is whether generalist judges can reliably determine “the knowledge of technol-

---

185. See *infra* Part III.A.1.

186. See, e.g., John F. Duffy, *On Improving the Legal Process of Claim Interpretation: Administrative Alternatives*, 2 WASH. U. J.L. & POL'Y 109 (2000).

187. See, e.g., Robert P. Merges, *As Many as Six Impossible Patents Before Breakfast: Property Rights for Business Concepts and Patent System Reform*, 14 BERKELEY TECH. L.J. 577 (1999) (summarizing complaints and proposals about Patent Office).

188. Wagner & Petherbridge, *supra* note 14, at 145.

ogists” at a reasonable cost.<sup>189</sup> This Part considers the ability of generalist judges to accurately and cheaply identify the general meaning of a claim term to a skilled person in the field of technology at the time of the invention. Part III.A focuses on the more extreme approach, increasingly popular in the case law, which treats the general meaning of a claim term as controlling, with very narrow and exacting exceptions. Part III.B addresses the more moderate position, endorsed in *Phillips*, which would require the skilled person’s general understanding and knowledge to be supplemented with the intrinsic evidence from the patent and prosecution history.

#### A. Generalist Judges and “Plain” Meaning

If, as proponents assume, determining the general or “plain” meaning of a claim term was a straightforward matter of identifying “the commonly-understood meaning” in the technical field at the time of the invention,<sup>190</sup> there would be little concern about the capacities of generalist judges. Claim construction under such an approach would require a finding of a historical fact—*i.e.*, the established meaning in the field at the time of the invention—and generalist judges are well suited to find historical facts. However, determining the general meaning of a claim term to a skilled person in the field at the time of the invention requires a series of difficult decisions, and judgment calls that introduce a serious risk of error and makes identifying the general meaning of a claim term anything but a simple finding of historical fact.

##### 1. The Difficulties of Determining General Meaning

A generalist judge attempting to identify the general meaning of a claim term in the technical field faces threshold problems in defining the inquiry and execution problems in carrying out the search for general meaning.

###### a. Threshold Problems

As a comprehensive approach to claim construction, the general or “plain” meaning perspective faces a significant threshold obstacle: some claim terms do not have a general meaning in the technical field at the time of the invention. Patentees sometimes create new words or new combinations of words to describe the new technology that the patent embodies.<sup>191</sup>

---

189. *Id.*

190. *See id.* at 28; *see also* Osenga, *supra* note 15, at 102-03 (recognizing that “it is difficult for the non-scientific district court judge, with limited experience in patent cases, to put himself into the shoes of an ordinary scientist,” but assuming understanding of PHOSITA can and should be basis for claim construction).

191. *See supra* Part II.B. Some have questioned the frequency of this. *See* Burk & Lemley, *supra* note 20, at 1752; *see also* Schierz, *supra* note 152, at 147 (concluding that in the artificial intelligence field “term usage increases in the academic community before becoming the subject of patent documents”).

Similarly, patent prosecutors have created specialized terminology, or “patentese,” that “mak[es] it excessively hard for the technical expert to comprehend the invention’s technical aspects through the patent.”<sup>192</sup> General meaning would be of little use to a judge construing these types of claim terms.

A second threshold problem is that the judge must choose which words in the claim to treat as a single interpretive unit—*i.e.*, whether to look for the general meaning in the technical field of a single word (perhaps “format” in the St. Clair example), a short phrase (“file formats”), or a longer phrase (“a plurality of computer image file formats”).<sup>193</sup> In other interpretive contexts, the judge’s familiarity with ordinary English usage will normally suffice to choose the proper interpretive unit, but the judge lacks background familiarity with technical terminology and patentese to reliably do so while construing claims. The general meaning approach does not permit the judge to consult the patent specification until after the “ordinary” or “plain” meaning is established. The judge is left to guess what words constitute a single phrase that will have a general meaning in the field, and the parties are likely to propose different combinations of words that better suit their respective interests. The likely result is that the judge will interpret claims in piecemeal fashion, since the extrinsic texts used to identify general meaning are more likely to define individual words or small phrases than longer or more complex phrases.<sup>194</sup> Because a full phrase can carry a very different meaning than the meaning derived from patching together definitions of individual words, the resulting claim construction will depart from the general meaning in the field whenever a skilled person would interpret a larger phrase together.<sup>195</sup>

Finally, the judge must determine whether an inquiry into the specialized meaning in the field is even required, or whether someone in the technical field would understand the claim term in the same way that a lay person—like the judge—would understand the term.<sup>196</sup> Due to self-interest and cognitive limitations, judges are likely to underestimate how often a term bears a specialized meaning in the technical field.<sup>197</sup> If a term does not have a specialized meaning, the judge can apply his or her own understanding, reducing the judges’ decision costs and increasing his or her time for other cases and leisure. Additionally, judges, like anyone, seek to confirm

---

192. Fromer, *supra* note 37, at 567-68.

193. Burk & Lemley, *supra* note 16, at 41-46.

194. *Id.* at 46.

195. *Id.* at 41-46.

196. See Phillips v. AWH Corp., 415 F.3d 1303, 1314 (Fed. Cir. 2005) (en banc).

197. See Menell et al., *supra* note 65, at 733-34 (“Some plain English terms can have technical meanings in particular fields.”).

their original hypotheses and beliefs (“confirmation bias”)<sup>198</sup> and be more confident that they have the right answer than they should be (“overconfidence bias”).<sup>199</sup> And to the extent that the judge’s own understanding reflects current knowledge or technology in the field, whether from learning about it in the case or from general knowledge, “hindsight bias” will cause the judge to project the current knowledge and developments in the field into the meaning at the time of the invention.<sup>200</sup> Recent opinions applying a general meaning approach support the intuition that judges tend to overestimate how often the general meaning in the field is the same as the judge’s own background understanding of a term. In these opinions, the judge simply states the “ordinary meaning,” presumably based on the judge’s own understanding, without identifying any source corroborating this as the understanding of a skilled person at the time of the invention,<sup>201</sup> even though *Phillips* suggested this would be inappropriate “[i]n many cases that give rise to litigation.”<sup>202</sup>

#### b. Execution Problems

Aside from the threshold problems, a generalist judge trying to identify the general meaning of a claim term in the technical field must undertake two legal fictions: construing claims retrospectively at the time of patent filing and stepping into the shoes of a skilled person in the technical field.<sup>203</sup> The counterfactual nature of these inquiries introduces additional sources of error.<sup>204</sup>

Originalist approaches to statutory and constitutional interpretation that look to meaning at the time of enactment similarly rely on counterfactual assumptions about the time of interpretation. In those areas, the relevant texts are often decades or even centuries old, whereas the gap between filing and interpretation in patent cases often will be a matter of only a few years

---

198. See Cass R. Sunstein, *Precautions Against What? The Availability Heuristics and Cross-Cultural Risk Perception*, 57 ALA. L. REV. 75, 99 (2005).

199. See Philip G. Peters, Jr., *Hindsight Bias and Tort Liability: Avoiding Premature Conclusions*, 31 ARIZ. ST. L.J. 1277, 1288 n.78 (1999).

200. Gregory N. Mandel, *Patently Non-Obvious: Empirical Demonstration that the Hindsight Bias Renders Patent Decisions Irrational*, 67 OHIO ST. L.J. 1391, 1402 (2006).

201. See, e.g., *In re Rambus, Inc.*, 694 F.3d 42 (Fed. Cir. 2012), *reh’g denied* (2012); *Thorner v. Sony Computer Ent’tmt Am. LLC*, 669 F.3d 1362 (Fed. Cir. 2012); *Retractable Techs., Inc. v. Becton, Dickinson & Co.*, 659 F.3d 1369 (Fed. Cir. 2011); *St. Clair Intell. Prop. Consultants, Inc. v. Canon Inc.*, 412 F. App’x 270 (Fed. Cir. 2011); *Arlington Indus., Inc. v. Bridgeport Fittings, Inc.*, 632 F.3d 1246 (Fed. Cir. 2011); *Decisioning.com, Inc. v. Federated Dep’t Stores, Inc.*, 527 F.3d 1300 (Fed. Cir. 2008); *Medegen MMS, Inc. v. ICU Med., Inc.*, 317 Fed. Appx. 982 (Fed. Cir. 2008); *Acumed LLC v. Stryker Corp.*, 483 F.3d 800 (Fed. Cir. 2007).

202. *Phillips v. AWH Corp.*, 415 F.3d 1303, 1314 (Fed. Cir. 2005) (en banc).

203. Schwartz, *supra* note 167 at 260.

204. See Osenga, *supra* note 15, at 102-03.



and generally no more than twenty-six years.<sup>205</sup> However, language used to describe new technology is likely to be more fluid than the language used in other interpretive contexts, which increases both the difficulty of identifying a source close enough to the time of filing to be reliable and the likelihood of error if the judge relies on a source from a slightly different time.<sup>206</sup>

The counterfactual need to step into the shoes of a skilled person in the technical field is a problem generally unique to patent claim construction. Identifying the exact field of the invention is fraught with difficulty and levels of abstraction problems, as inventions can open entirely new fields or, more commonly, cross between fields or expand existing fields.<sup>207</sup> The level of skill in the field is easier to articulate—it is generally treated as median or common skill—but it is as hard or harder to determine, requiring consideration of the typical education in the field, complexity of the technology, rapidity of change in the field, and existing approaches in the field.<sup>208</sup>

Thus, to reliably identify the general meaning of a claim term in the technical field at the time of invention, the judge must find a source that accurately reflects the correct skill level, the precise field, and the exact time of the invention. The odds of finding a specialized source in the exact field at the precise time of the invention are low. More likely, a judge will confront multiple potential sources, each imperfect in skill, field, and/or time, with the litigants incentivized to engage in a costly arms races to identify the most helpful sources and definitions for their position, regardless of how obscure or actually reflective of a skilled person's understanding.<sup>209</sup> This risk of “dictionary shopping” is familiar in other interpretive areas,<sup>210</sup> but is probably more acute in patent law because of the increased breadth, discretion, and range of sources that result from the additional variables of identifying the technical field and skill level.<sup>211</sup>

Even if a judge could find a reliable source for a term's meaning in the field at the time of the invention, there is no reason to think that this is the “general” meaning. As Professors Burk and Lemley have noted, a skilled person would understand a term to “have a range of meanings, from narrow

---

205. Patentees are entitled to a right to exclude for twenty years from filing of the patent application and must sue for infringement damages within six years of the infringement. 35 U.S.C. §§ 154(a)(2), 286 (2012).

206. See Johnson, *supra* note 15, at 535.

207. Burk and Lemley give the example of a patent related to DNA, which could be seen as arising in the field of biochemistry, cell biology, molecular biology, or, at a higher level of generality, biology. Dan L. Burk & Mark A. Lemley, *Is Patent Law Technology-Specific?*, 17 BERKELEY TECH. L.J. 1155, 1189 (2002).

208. *Id.*

209. With rates approaching \$400/hour for even junior associates at the firms regularly handling complex patent cases, these search costs can be substantial.

210. See FRANK B. CROSS, *THE THEORY & PRACTICE OF STATUTORY INTERPRETATION* 28 (2009).

211. See Johnson, *supra* note 15, at 535.

to broad,” so that, for example, a biotechnologist would understand the term “monoclonal antibody” but also would understand that it could be limited to “IgM mouse-derived antibodies” or extend to “any antibody, including chimeric and humanized antibodies” depending on the context in which it is used.<sup>212</sup> More recent cases applying a general meaning approach instruct courts to simply choose the broadest of possible meanings a term could bear in the field.<sup>213</sup> However, a term that is normally used narrowly may occasionally be used more broadly, and there is no reason to presume that the broadest meaning that can be derived from the wide range of possible sources, definitions, and levels of abstraction accurately reflects a skilled person’s general understanding of the term at the time of the invention, the purported goal of this approach.

Older general meaning cases did permit resort to the context of the specification and prosecution history if the judge first determined from extrinsic sources that multiple possible meanings “would have been attributed to the words of the claims by those skilled in the art.”<sup>214</sup> A judge following these instructions is likely to systematically underestimate how often a term could bear multiple meanings to a skilled person, as the judge incurs lower decision costs from identifying a single meaning from extrinsic sources, rather than identifying multiple meanings in the extrinsic sources and then having to parse through the intrinsic record to choose between them. Similarly, hindsight and confirmation biases suggest that the judge will tend to conclude that the only possible meaning is the one closest to her own understanding of the term or knowledge of the present state of technology. Finally, an outcome- or policy-motivated judge<sup>215</sup> can simply select the best meaning for his or her preferred outcome and conclude that no ambiguity exists that would justify consulting the intrinsic record.<sup>216</sup>

Expert testimony offers little help in solving the difficulties for a generalist judge in identifying the general meaning of a claim term in the technical field at the time of invention. Not only does the use of expert testimony increase litigation costs,<sup>217</sup> but the same difficulties exist in determining whether the expert had the precise (or close enough) skill in the precise (or

---

212. Burk & Lemley, *supra* note 16, at 40.

213. *E.g.*, *Thorner v. Sony Computer Entm’t Am. LLC*, 669 F.3d 1362, 1367 (Fed. Cir. 2012).

214. *Tex. Digital Sys., Inc. v. Telegenix, Inc.*, 308 F.3d 1193, 1205 (Fed. Cir. 2002).

215. Patent law may not be an area in which most district judges have strong pro-patent or anti-patent policy preferences, though some federal districts, such as the Eastern District of Texas, are regarded as having a pro-patentee bias, in order to attract litigation that boosts local economies. *See, e.g.*, Julie Creswell, *So Small a Town, So Many Patent Suits*, N.Y. TIMES, Sept. 24, 2006, at A1. Federal Circuit judges are likely to have strong policy views about patent law and the appropriate scope of protection.

216. *See Mullally, supra* note 87, at 368.

217. Technical experts in patent cases generally charge at least \$350/hour, and each hour spent by the expert is likely to be matched by the attorney managing the expert.

close enough) field at the precise (or close enough) time of the invention. An expert who had greater or lesser skill at the time of invention, was in a related field, or was skilled before or after the relevant time, may substitute—intentionally or inadvertently—his or her own understanding for that of a skilled person in the field at the time of the invention. Expert testimony also introduces errors from hindsight bias and the fact that it “is generated at the time of and for the purpose of litigation and thus can suffer from bias that is not present in intrinsic evidence.”<sup>218</sup>

Nor is a generalist judge well suited to guard against or correct these problems with expert claim construction testimony. The judge lacks the expertise or background knowledge and experience to evaluate the accuracy or reasonableness of the expert’s purported general meaning in the field and cannot use the context of the specification or prosecution history to evaluate what constitutes the “general” meaning in the field. The judge can only evaluate the expert’s performance as a witness, which favors professional experts over those actually working in the field and accentuates the litigation bias of expert testimony.

## 2. Consequences of Errors

A core assumption of the general meaning approach is that this meaning is readily identifiable and will enhance public notice and predictability in patent law.<sup>219</sup> Indeed, to proponents, the notice and predictability it offers is sufficient to tolerate the acknowledged significant risk that this approach will result in claim scope broader than warranted by the patentee’s contribution to the field.<sup>220</sup>

However, as demonstrated in the prior section, the ease of identifying the general meaning to a skilled person in the field is superficial, at best. The difficulty, variability, and unconstrained discretion introduced at each of the various stages in this inquiry create a significant possibility that a competitor predicting *ex ante* what the claim covers will reach a different outcome than the construction ultimately adopted by a generalist judge in litigation.<sup>221</sup> Patentees have incentives to exacerbate the difficulties a generalist judge has identifying the general meaning of a claim term by choosing broad, vague, and ambiguous language that increases the range of possible

---

218. Phillips v. AWH Corp., 415 F.3d 1303, 1318 (Fed. Cir. 2005) (en banc).

219. See *supra* Part II.A.

220. Wagner & Petherbridge, *supra* note 14, at 145; see *Retractable Techs., Inc. v. Becton, Dickinson & Co.*, 659 F.3d 1369, 1371-72 (Moore, J., dissenting from the denial of the petition for rehearing en banc).

221. See *Burk & Lemley*, *supra* note 20, at 1752. These stages include: choosing the interpretive unit, choosing whether to apply the judge’s own understanding or to look for a specialized meaning, identifying the field and skill level of the invention, finding a source at the skill level in the field at the time of the invention, and choosing between multiple imperfect sources and multiple meanings or levels of abstraction. See *supra* Part III.A.1.

sources and meanings and maximizes the patentee's flexibility and the potential reach in subsequent litigation.<sup>222</sup>

This unpredictability is particularly problematic because it is closer to true uncertainty ("unknown unknowns"), not just risk ("known unknowns").<sup>223</sup> Even a competitor well versed in the meaning to a skilled person at the time of the invention will have difficulty anticipating (1) how an unknown judge with an unknown background will understand the term years later; (2) the wide range of possible meanings that can be derived from tangentially relevant sources; or (3) meanings that do exist at the time of its decision and are only derived years later from hindsight bias based on subsequent technological developments or the litigation driven assertions of a paid expert. Thus, the unpredictability of a general meaning approach to claim construction is difficult to plan around, such as by factoring into the cost-benefit analysis in deciding whether to launch a product.<sup>224</sup>

### B. *Generalist Judges and the Phillips Approach*

Perhaps the line of cases that increasingly emphasizes just the general meaning of a claim term in the technical field goes too far in limiting reliance on the patent specification. Maybe generalist judges could overcome the difficulties of identifying the general meaning of claim terms in the field of the invention by supplementing the skilled person's general knowledge and understanding with the additional information provided in the intrinsic record. The resulting interpretation then would be consistent with *both* the general meaning in the field and the context of the specification. This approach could eliminate or mitigate some of the problems described above, such as the lack of an existing meaning in the field, the choice of interpretive unit, the choice between multiple meanings from several imperfect sources, and the evaluation of expert testimony.

However, this is the basic approach that the Federal Circuit has endorsed for the past twenty years, including in *Phillips*—claim terms must reflect a skilled person's understanding but also must be consistent with the

---

222. See BESSEN & MEURER, *supra* note 10, at 56-57. If the broad claim is rejected in prosecution, the patentee can cheaply narrow the claim slightly by amendment until it obtains the broadest possible language the examiner will allow. In litigation, the patentee will benefit from the presumption of validity. Nor does a general meaning approach offer any countervailing incentive for the patentee to say more about the invention, as some have suggested. See Wagner & Petherbridge, *supra* note 14, at 144. This is because "patentees rationally have little to no incentive to offer more information than the patent laws require and have an incentive to obfuscate information they provide whenever possible" so as to limit competitors' efforts to design-around the patent, develop improvements, or practice the invention after patent expiration. See Fromer, *supra* note 37, at 552-53.

223. See Richard A. Epstein, *In Defense of the Contract at Will*, 51 U. CHI. L. REV. 947, 969 (1984).

224. See *id.*

specification.<sup>225</sup> The result has been what Professors Wagner and Petherbridge call a “standardless, ad-hoc determination of claim meaning”<sup>226</sup> that has received virtually unanimous criticism from commentators.<sup>227</sup> These problems derive from two sources.

First, to construe claims from the skilled person’s perspective, the court must determine the skilled person’s background knowledge and understanding before it determines how the context of the patent and prosecution history affects this background understanding. This approach introduces many of the same difficulties, opportunities for error, and costs described in the prior section. Given these difficulties, it is unsurprising that district court and Federal Circuit judges rarely address the skilled person’s background knowledge and understanding or cite to extrinsic texts or expert testimony to understand how a term is generally used in the field.<sup>228</sup> Although doing so may reduce decision costs, it increases error costs for an approach meant to capture a skilled person’s understanding of the claim term.

The second problem is that the judge must decide when the context of the intrinsic record can limit or change the general meaning in the field. The cases and scholarship normally frame this question as whether a particular construction properly reads the claim term in the context of the specification or improperly imports a limitation from the specification into the claim.<sup>229</sup> The line between these two canons is notoriously difficult to draw,<sup>230</sup> and patentees have the incentive to blur this line to retain flexibility.<sup>231</sup> The Federal Circuit has sought to guide this inquiry with various canons: references to “the invention” or “the present invention” are defining but references to “an embodiment” or “the preferred embodiment” are merely exemplary, statements that distinguish the prior art are normally defining, statements in certain sections of the patent are more likely to be defining, and consistent and uniform usage may be defining.<sup>232</sup> These canons have had marginal impact, as they do little to target a skilled person’s perspective (the purported goal of the *Phillips* approach),<sup>233</sup> are normally discretionary not

---

225. See *supra* Part II.A; see also *Phillips v. AWH Corp.*, 415 F.3d 1303, 1321 (Fed. Cir. 2005) (en banc).

226. Wagner & Petherbridge, *supra* note 14, at 144.

227. See, e.g., Osenga, *supra* note 15, at 68-73.

228. See Anderson & Menell, *supra* note 99, at 55 (Federal Circuit); Osenga, *supra* note 15, at 103 (district courts).

229. *Phillips v. AWH Corp.*, 415 F.3d 1303, 1323 (Fed. Cir. 2005) (en banc); Cotropia, *supra* note 122, at 1866-67.

230. Cotropia, *supra* note 115, at 1867.

231. Menell et al., *supra* note 65, at 747-48.

232. See *id.* at 750-52; CHISUM, *supra* note 90, § 18.03[2][c][ix] & nn.666-670.

233. See Anderson & Menell, *supra* note 99, at 67-68, 72.

mandatory,<sup>234</sup> have been inconsistently applied,<sup>235</sup> and are easily avoided by competent patent drafters.

The basic problem with an approach that seeks to reconcile general meaning in the field and specific meaning from the context of the patent is that it is virtually impossible for generalist judges to know whether a skilled person would deem a statement in the specification as sufficiently clear and definitional to limit or alter the general understanding that the skilled person had before encountering the patent.<sup>236</sup> The suggestion in *Phillips* that this question would be clear on a case-by-case basis has not been borne out.

#### IV. GENERALIST JUDGES, SPECIFIC MEANING, AND AN ORDINARY READER STANDARD

Given the problems with identifying the general meaning of a claim term in the technical field at the time of the invention, it is not surprising that one line of Federal Circuit cases has moved towards relying only on the specific meaning of a claim term in the context of the patent, without regard to how it is normally used in the technical field. Focusing just on the context of the patent eliminates or reduces many of the problems that the general meaning approach poses for generalist judges. For example, a judge can determine what words or phrases in the claim to interpret together by looking at what words or phrases are used together in the intrinsic record. Nor would the judge encounter the cost and difficulty of finding a source at the right skill level in the right field at the right time of the invention, or choosing between several imperfect sources. The relevant source for interpretation would be the publicly-available patent and prosecution history, written near the time of the invention and, by definition, at the skill level and in the field of the invention.

The movement towards exclusive reliance on the context of the patent is promising from the perspective of tailoring claim construction to the abilities and limitations of generalist judges. As set forth below, however, Part IV.A contends that the approach adopted in these cases—construing claim terms in whatever way is necessary to reflect the invention disclosed in the specification—is no more feasible for generalist judges than the general meaning approach. Part IV.B proposes an alternative way to limit claim construction to the specific meaning in the context of the patent—giving claim terms the meaning an ordinary reader would understand based on the use of the specific term in the specification and prosecution history—and contends that this is better suited for generalist judges. Part IV.C suggests that an ordinary

---

234. See Menell et al., *supra* note 65, at 745-52.

235. See Golden, *supra* note 72, at 379.

236. Use of expert testimony leaves the judge no better off, since each side would present an expert willing to take its preferred position.

reader standard is not only suitable for generalist judges but also normatively appealing.

### A. Generalist Judges and the Focus on the Disclosed Invention

Scholars and judges emphasizing reliance on the patent specification and prosecution history in claim construction have increasingly favored a two-step approach. Under this approach, the judge would first determine what a skilled person in the field would conclude the patentee actually invented and disclosed in the specification, and, second, tailor the claim language in whatever way is necessary to capture this invention, regardless of the words actually chosen.<sup>237</sup> Proponents of this “disclosed invention” approach believe that “[i]n almost all cases, the inventors, and their patent solicitors, knew what was invented and generally disclosed their invention in competent language.”<sup>238</sup> Even assuming the first part is true, the second is overly optimistic, considering the capacities of generalist judges. In practice, the disclosed invention approach is likely to be as difficult, error prone, and costly for generalist judges as the general meaning approach.

#### 1. Problems with Disclosed Invention

There is an ahistorical tendency to the disclosed-invention approach. In the first half of the 1800s, there was no requirement for claims, with judges required to determine the patentee’s invention and the scope of its rights directly from the “full explanation of the invention” in the specification, essentially what proponents of the disclosed-invention approach suggest.<sup>239</sup> Because the specification included a mixture of information about the prior art, the invention itself, and parts or processes that operated in conjunction with the invention, the judge had to “ascertain[ ] the exact invention of the patentee by inference and conjecture, derived from a laborious examination of previous inventions, and a comparison thereof with that claimed by him.”<sup>240</sup> Congress added the claim requirement exactly because of the problems generalist judges had with this task, transferring the burden of determining the patentee’s “actual invention” to the relative experts in the Patent Office.<sup>241</sup> Proponents of the disclosed-invention approach offer no reason to think that generalist judges are better equipped to execute this task for today’s complex patents on semiconductors, software concepts, and biotech-

---

237. See *supra* Part II.A.

238. *Arlington Indus., Inc. v. Bridgeport Fittings, Inc.*, 632 F.3d 1246, 1257 (Fed. Cir. 2011) (Lourie, J., concurring in part and dissenting in part).

239. Karl B. Lutz, *Evolution of the Claims of U.S. Patents*, 20 J. PAT. OFF. SOC’Y 134, 135 (1938).

240. *Keystone Bridge Co. v. Phoenix Iron Co.*, 95 U.S. 274, 278 (1877); see *Merrill v. Yeomans*, 94 U.S. 568, 570 (1877).

241. See *Keystone Bridge*, 95 U.S. at 278.

nology than they were for the comparatively simple patents on basic machines and industrial processes.<sup>242</sup>

There is good reason to believe they are not. Defining the patentee's "actual invention" based on the disclosure in the specification is exceedingly difficult. As Professor Chiang has recognized, defining the invention presents a classic levels of abstraction problem.<sup>243</sup> Professor Chiang offers the simple, but illuminating, example of the Wright Brothers, who built and disclosed "a single barely-flying wooden glider."<sup>244</sup> How should we describe their "actual invention": a flying machine? A flying machine with wings? A flying machine with wings and rudders? A wooden flying machine with wings and rudders?<sup>245</sup> Scholars have proposed alternative ways to resolve this level of abstraction problem, variably describing the "actual invention" as "a tangible and working embodiment";<sup>246</sup> "the set of disclosed embodiments" in the specification and their shared "essential elements . . . that enable them to produce the sought after result;"<sup>247</sup> the inventor's "real-space activities and recognitions" memorialized within the patent;<sup>248</sup> or an inherent policy decision about social benefits, necessary incentives, social costs, and importance.<sup>249</sup>

Scholars have the luxury of debating this interesting question, but judges must make decisions in real-world cases.<sup>250</sup> How are they supposed to tailor claim language to the "actual invention" if scholars cannot even agree on how to define the "actual invention"? Even if scholars did coalesce around one solution to the levels of abstraction problem, terms like "essential elements," "recognitions," "importance," "social benefits," and "costs" raise difficult scientific (and economic) questions not well suited for direct determination by generalist judges in the context of litigation.

The content of the specification complicates the task of identifying the "actual invention." The specification describes the invention at various levels of generality, from its "nature and gist" to the best way the inventor knows of implementing it, exacerbating the inherent levels of abstraction problem.<sup>251</sup> Further, these varying descriptions of the invention are mixed with descriptions of the prior art, specific materials, experimental results, industrial applications, and other such peripheral content. The patentee's in-

---

242. See, e.g., Burk & Lemley, *supra* note 20; Cotropia, *supra* note 122; Liivak, *supra* note 28.

243. Chiang, *supra* note 36, at 1122-23.

244. See Tun-Jen Chiang, *Defining Patent Scope by the Novelty of the Idea*, 89 WASH. U. L. REV. 1211, 1213 (2012).

245. See *id.*

246. Chiang, *supra* note 36, at 1118.

247. Oskar Liivak, *Finding Invention*, 40 FLA. ST. U. L. REV. 57, 73-74 (2012).

248. Cotropia, *supra* note 122, at 1876-77.

249. See Chiang, *supra* note 36, at 1134-38.

250. See VERMEULE, *supra* note 29, at 2-4.

251. See *supra* Part I.A.1.



centives are to be as vague and unclear as possible about what exact content or level of generality reflects the invention, both to avoid limiting the scope of its patent and to obfuscate useful information about the invention from competitors.<sup>252</sup> Separating the parts of the specification that describe the invention and the parts that describe other information—*i.e.*, prior art or working examples—requires a detailed understanding of several technical concepts, including: existing knowledge in the field, how the invention differs from the prior art, the common principles or operation underlying each working example, and the substitutability of various features of the invention. This task is better suited for scientists than generalist judges.<sup>253</sup> Indeed, “disclosed invention” cases emphasize that the actual invention is determined from a skilled person’s perspective—*i.e.*, what the skilled person would understand to be the invention from reading the specification—introducing the same difficulties of identifying the precise field and skill level and background knowledge and understanding of the skilled person.<sup>254</sup>

Forcing judges to undertake a direct inquiry into the “actual invention” on a case-by-case basis is a recipe for error: it introduces significant risk of hindsight bias or outcome bias (*i.e.*, the invention will be defined in the way that conforms best to the current state of technology or the judge’s preferred result), offers little constraint on judicial discretion, and is prohibitively expensive.

## 2. Consequences of Errors

The disclosed-invention approach is primarily justified as necessary to ensure proportionality, *i.e.*, that the patentee’s exclusive rights do not extend beyond the contribution the patentee made to the field.<sup>255</sup> If this approach is compared to a general meaning approach, then a direct effort to construe claims to capture the invention disclosed in the specification almost by definition offers greater proportionality.

However, the difficulties a generalist judge will face in implementing the disclosed-invention approach severely undermine its promised proportionality. Patent prosecutors purposefully include broad or ambiguous language in the specification in an effort to maximize future patent scope.<sup>256</sup> For example, patentees often include broad statements about the importance or

---

252. See Fromer, *supra* note 37, at 567-68.

253. Relying on expert testimony would introduce the error and decision costs previously discussed with regard to general meaning. See *supra* Part III.A.1.

254. See Liivak, *supra* note 28, at 44.

255. See *supra* Part II.A.

256. See Fromer, *supra* note 37, at 567-68. It is optimistic to suggest, as some proponents have, that the disclosed-invention approach would “cause[ ] patent prosecutors to include more information in the specification in hopes of expanding what constitutes the disclosed invention.” Cotropia, *supra* note 34, at 132. Rather, they would have the incentive to include as broad, vague, and ambiguous descriptions as they could to exploit the difficulty generalist judges have in identifying the invention and thereby maximize future flexibility. The de-em-

achievement of the invention in the Summary of the Invention, statements that seem to be puffery or aspirational when compared to the more limited advance that the patentee describes in other portions of the patent. But, given the problems a generalist judge will have in parsing through the detailed and varied content of the specification, a judge may credit these statements as reflecting the “actual invention.” This is especially true because these broad statements often are introduced with language such as “This invention relates to . . .”, whereas the more detailed descriptions in other parts of the patent are normally characterized as describing “an embodiment” or “an example.” Hindsight bias may reinforce the tendency to credit these broader statements about the invention, as doing so is more likely to capture how the field of technology subsequently developed and what it encompasses today.

The problems a generalist judge would have implementing the disclosed-invention approach can also create underbreadth. The largest part of the patent describes specific examples—examples that often include very particular features, materials, measurements—reflecting the patentee’s “best mode” or actual commercial product. Since these descriptions are normally more concrete than descriptions of the invention at higher levels of generality, the judge erroneously may treat them as an essential part of the “actual invention.”

Balanced against the uncertain proportionality benefits of a disclosed-invention approach is the *ex ante* unpredictability created by its open-ended nature. The exclusive focus on the disclosure of the publicly-available patent document may actually enhance predictability as compared to the broad search for any tangentially relevant extrinsic source permitted when claim construction focuses on the general meaning of claim terms.<sup>257</sup> However, a wide range of possible constructions result from the need to identify the right level of abstraction for the “invention,” identify the invention at this level of abstraction from the content filled specification, and then determine the appropriate language to capture this “invention.” As a result, there is a significant possibility that a generalist judge in litigation will reach a different conclusion than a competitor would *ex ante*.

### B. Generalist Judges and the Ordinary Reader Standard

To this point, this Article has criticized existing claim construction approaches for their high error and decision costs when applied by generalist judges. Errors and decision costs are inevitable under any interpretive approach, however.<sup>258</sup> This is especially true in claim construction, where there

---

phasis on the claim language also would give patentees little reason to spend money drafting quality claims. See Chiang, *supra* note 163, at 40-41.

257. *Interdigital Commc’ns, LLC v. Int’l Trade Comm’n*, 690 F.3d 1318, 1335 (Fed. Cir. 2012) (Newman, J., dissenting).

258. See VERMEULE, *supra* note 29, at 109.

is a measure of inherent indeterminacy in converting both the technical content of the patentee's invention, and the intangible concepts of intellectual property rights, into words.<sup>259</sup> The criticisms of the various approaches are largely irrelevant unless an alternative approach exists that is better suited and less costly for generalist judges to apply.<sup>260</sup> This Section proposes such an approach: construing claim terms based on how an ordinary reader would understand a term from its use in the patent and prosecution history.

### 1. Simplifying Claim Construction: An Ordinary Reader Standard

The common problem with the various claim construction approaches is that they ask generalist judges to be scientists, not lawyers. Whether tasked with determining the meaning a term normally bears to a skilled person in the field, determining how a skilled person would reconcile the context of the patent with her background knowledge and understanding, or deriving what a skilled person would deem the patentee's "actual invention" from the varied disclosure of the specification, generalist judges are ill-suited to undertake the counterfactual role of a technical person in the field of the invention.<sup>261</sup>

Those who recognize the difficulties of asking a generalist judge to take on the perspective of a skilled technical person generally favor increasing the role of extrinsic texts and expert testimony to educate the judge about the scientific principles and the background knowledge and understanding of a skilled person.<sup>262</sup> As an empirical matter, it is unclear whether greater access to extrinsic texts and expert testimony will improve the ability of judges to step into the shoes of a technical person. It may. Greater use of extrinsic texts and expert testimony will not alleviate many of the problems a judge will have doing so, however, when he or she must identify the exact field of the invention and skill level in the field, reconcile extrinsic sources with the intrinsic record, or determine what level of abstraction constitutes the "actual invention."<sup>263</sup> Moreover, increased reliance on extrinsic sources increases incentives for strategic behavior by litigants, such as "dictionary-shopping"

---

259. See, e.g., *Autogiro Co. of Am. v. United States*, 384 F.2d 391, 396-97 (Ct. Cl. 1967); Schwartz, *supra* note 167, at 259-60.

260. See VERMEULE, *supra* note 29, at 109.

261. See, e.g., Schwartz, *supra* note 167, at 260.

262. See Anderson & Menell, *supra* note 99, at 67-68 (proposing greater use of technical experts and experts on patent drafting in claim construction); Osenga, *supra* note 15, at 103 ("[D]istrict courts must be encouraged to make factual findings about who exactly this PHOSITA is in any given case and what he knows. . . ."); Wagner & Petherbridge, *supra* note 14, at 144-45 (proposing an approach by which "the knowledge of technologists determines the meaning" of claim terms).

263. See Mark D. Janis & Timothy R. Holbrook, *Patent Law's Audience*, 97 MINN. L. REV. 72, 98-99 (2012) (noting that "a fully-fleshed PHOSITA" would not help resolve tension between general and specific meaning inherent in *Phillips* approach).

and litigation-driven expert testimony.<sup>264</sup> Thus, a greater emphasis on extrinsic evidence may result in more biased information being presented to the court, decreasing the court's ability to accurately capture the skilled person's understanding.<sup>265</sup>

The speculative gains from increased reliance on extrinsic texts and expert testimony are accompanied by definite costs. Extrinsic evidence increases the costs of claim construction, both for the litigants identifying and preparing this evidence and for the judge from processing and evaluating it.<sup>266</sup> In interpretive situations of speculative gains and definite costs, judges are wise to "restrict the range of information they attempt to collect and reduce the complexity of their behavioral repertoire."<sup>267</sup>

Rather than increase reliance on the skilled person's perspective, claim construction would be better off by eliminating it and replacing it with a more straightforward ordinary reader standard that focuses on the substantive and linguistic context provided by the publicly-available patent and prosecution history itself, and not the background knowledge or understanding of any particular person. A judge asked to interpret a claim term would determine the meaning that term would bear to the ordinary reader based on the contextual clues surrounding *the use of that specific claim term* in the publicly-available patent and prosecution history. The judge would *not* have to undertake the far more complicated, error-prone, and costly tasks of searching the scientific literature to determine the general way in which that a technical person would understand the term, or, like a peer reviewer for a scientific journal, identifying what parts of the specification represent existing knowledge and what represent the patentee's advancement.<sup>268</sup> Rather, the judge would engage in the more familiar task of determining how an ordinary reader would understand a term based on the contextual clues that surround its use in the patent document and accompanying prosecution history, which is more similar to what is required in other interpretive areas.<sup>269</sup>

---

264. See Mullally, *supra* note 87, at 368.

265. See VERMEULE, *supra* note 29, at 108 (explaining that additional information may not increase accuracy of decision-making if it is "particularly distorting, inflammatory, or burdensome when considered by a decision maker with limited capacity to absorb and evaluate the information").

266. See Cotropia, *supra* note 35, at 88-90.

267. VERMEULE, *supra* note 29, at 5.

268. See Frank H. Easterbrook, *Text, History, and Structure in Statutory Interpretation*, 17 HARV. J.L. & PUB. POL'Y 61, 69-70 (1994) ("Generalists should be modest and simple. While recognizing that specialists might produce a more nuanced approach, generalists must see that the process and error costs are much higher when they try to do the same thing.").

269. See e.g., 2A NORMAN J. SINGER & J.D. SHAMBLE SINGER, STATUTES & STATUTORY CONSTRUCTION § 45:2 (7th ed. 2007) (explaining that a word is a symbol that directs the reader to a referent and that interpretation is the effort to make the referent for a specific word in dispute as clear as possible from the information and evidence presented).

Scholars seem to assume that interpretation from a skilled person's perspective is a necessity for claim construction.<sup>270</sup> To be sure, the skilled person's perspective is a common feature of patent law—used, for example, to evaluate whether a patent was a sufficient advance so as to be non-obvious and to determine whether the specification adequately teaches how to make and use the invention—and it is inevitable that generalist judges to some extent must step into the shoes of scientists to resolve patent cases.<sup>271</sup> In other areas of patent law, the skilled person's perspective is a statutory requirement<sup>272</sup>; for claim construction, however, it is a judicially-created doctrine of recent vintage, attributable to the Federal Circuit, not Supreme Court mandate.<sup>273</sup> Aside from the statutory mandate, the skilled person's perspective is inevitable in other doctrinal areas, as it is impossible to know whether an invention is obvious in light of existing knowledge or whether a patent adequately explains how to make and use the invention except in the context of people operating in the technical field. But that does not mean that judges need to step into the shoes of scientists for every issue in a patent case if there is a viable alternative. With claim construction, the disclosure of the specification, rather than the perspective of a skilled person, can provide the court with sufficient context to interpret the term.<sup>274</sup>

The most thoughtful defenses of the skilled person's perspective for claim construction point to the basic linguistic notion that words have no inherent meaning and only acquire meaning from the shared reaction to texts of the relevant "community of readers [or listeners]."<sup>275</sup> However, the work of John Golden has driven a growing recognition that it is inaccurate to assume that skilled people are the "community of readers" of patent claims.<sup>276</sup> As an initial matter, there is the well-recognized, though probably

---

270. See Mark A. Lemley, *The Changing Meaning of Patent Claim Terms*, 104 MICH. L. REV. 105, 106 (2005); Osenga, *supra* note 15, at 101-04.

271. See Burk & Lemley, *supra* note 207, at 1185-87.

272. See 35 U.S.C. § 103 (2012) (adopting "person having ordinary skill in the art" standard for obviousness); *id.* § 112(a) (specification must enable "any person skilled in the art to which it pertains" to make and use it).

273. See Burk & Lemley, *supra* note 207, at 1187; Golden, *supra* note 72, at 348-68.

274. The unique context provided by the specification, which lacks parallel in other interpretive areas, also explains the apparent disconnect of applying an ordinary reader standard to patent claims when technical terms in statutes and contracts are normally construed from a technical perspective in the field. In those fields, there is no choice but to rely on a technical perspective because there is no accompanying description from which an ordinary reader can derive meaning for those technical terms. See SCALIA & GARNER, *supra* note 96, at 73; RESTATEMENT (SECOND) OF CONTRACTS § 202(3)(b) (1981); *id.* § 202 cmt. f (1981) (noting that technical terms should not be interpreted from technical perspective if context shows another meaning was intended).

275. See Easterbrook, *supra* note 268, at 61; Frank H. Easterbrook, *Statutes' Domains*, 50 U. CHI. L. REV. 533, 533 n.2, 536 (1983); see also Osenga, *supra* note 15, at 101-02 (relying on linguistic theory to endorse PHOSITA standard for claim construction).

276. See Anderson & Menell, *supra* note 99, at 67-68; Golden, *supra* note 72; see also Janis & Holbrook, *supra* note 263.

overstated, belief that skilled people in technical fields do not read patents.<sup>277</sup> Even if skilled people do read patents, however, it does not mean that they read, focus on, or understand the *claims*. The specification provides a substantive technical disclosure, whereas claims define the legal boundaries. A skilled person reading a patent is more likely to focus on the specification and ignore the claims for two reasons.<sup>278</sup> First, the specification bears at least a remote similarity to a scientific journal article,<sup>279</sup> while claims are unfamiliar entities unique to patent law. In instructing scientists how to read patents, one publication advises them to “ignore the claims section at the end of the patent. These are lawyers talking to lawyers; rarely is there useful data there.”<sup>280</sup>

Second, as Golden explains, “[d]ecisions that claim interpretation is meant to inform—such as whether to pursue a particular course of research and development, to launch a new product or service, to invest in another’s efforts to do either of these, or to make one’s own separate business reliant on a potentially infringing product or service—are business decisions typically made by people having little, if any, skill in the relevant technology.”<sup>281</sup> Thus, “because claims are written to define legal bounds rather than to communicate technological understanding, business decision-makers, lawyers, and patent examiners are more likely than ordinary artisans to be the real parties in interest for questions about claim meaning,” as is also true for generalist courts.<sup>282</sup>

On the other hand, Golden’s further suggestion that skilled people should not even be considered a *part* of the audience for patent claims<sup>283</sup> assumes a sophisticated company seeking to introduce a competing product in which the business decision makers are distinct from the skilled people and there is ready access to patent lawyers in choosing a course of conduct.<sup>284</sup> In many other settings—smaller companies; larger companies with limited in-house counsel; researchers at universities, hospitals, and other research organizations with limited access to counsel; and individual inventors—skilled people may have no choice but to read patent claims.<sup>285</sup> A

---

277. See Lisa Larrimore Ouelette, *Do Patents Disclose Useful Information?*, 25 HARV. J.L. & TECH. 545, 557-61, 570 (2012) (summarizing arguments that innovators do not read patents but finding that 64% of surveyed nanotechnology researchers had read patents).

278. See Golden, *supra* note 72, at 368-69.

279. See Ouelette, *supra* note 277, at 553-54.

280. Harry Robson, *How to Read a Patent*, in VERIFIED SYNTHESSES OF ZEOLITIC MATERIALS 79 (Harry Robson ed., 2d rev. ed. 2001).

281. Golden, *supra* note 72, at 370.

282. See *id.* at 369, 376.

283. See *id.* at 368-69, 383 (proposing “a patent attorney with access to the knowledge of an ordinary artisan” perspective for claim construction).

284. See *id.* at 369-73, 381.

285. See Ouelette, *supra* note 277, at 556, 574 (finding that 64% of nanotechnology researchers had read patents and 62% of those who had did so to determine whether their own work was patentable).

mixed audience thus consumes patent claims, including generalists (judges, business people, and some individual entrepreneurs), semi-specialists (patent attorneys and examiners), and skilled people (researchers, technical advisors to patent attorneys, and individual inventors). Given their divergent backgrounds and capabilities, the closest that this “community of readers” can come to a common basis for understanding claim terms is to construe the claims from the perspective of an ordinary reader and to focus on the substantive and linguistic clues exclusively provided by the context of the patent and prosecution history.<sup>286</sup>

## 2. Obstacles to an Ordinary Reader Standard

There are three legitimate, though ultimately unpersuasive, concerns about the ability of a generalist judge to give claim terms the meaning they would have to an ordinary reader in the context of the patent and prosecution history: (1) the lack of technical context for technical terms; (2) insufficient information in the intrinsic record to construe the term; and (3) insufficient guidance for the judge.

### a. Technical Context

An initial objection to an ordinary reader standard for claim construction is that it takes technical words out of their technical context and therefore provides an insufficient basis on which to understand technical terms.<sup>287</sup> As an initial matter, scholars have recognized that “[m]ost of the terms the [Federal Circuit] construes are not technical terms,” but rather ordinary English words, terms of degree (like “about”), or patentese.<sup>288</sup> The dispute in these cases is not about the general, technical meaning of the term, but instead how it is being used in the patent. For example, a dispute about the term “a dosage of about 70 mg” is really about how close to 70 mg the dosage has to be to fit within what is being disclosed in the patent. In these instances, it is not the general technical context that is important but the patentee’s description of the dosage in the context of the patent and prosecution history.

Moreover, the patent provides substantial information about the technical context.<sup>289</sup> This technical context is, by definition, in the field, at the skill level, and near the time of the invention. It also is provided at the earliest

---

286. Cf. Frederick Schauer, *Statutory Construction & The Coordinate Function of Plain Meaning*, 1990 SUP. CT. REV. 231, 251, 254-55 (1990) (advocating textualism in statutory interpretation because Supreme Court justices’ common understanding of the basic English or lawyer’s English in which statutes are written provides “a way in which people with potentially divergent views and potentially different understandings of what the context would require may still be able to agree”).

287. See Osenga, *supra* note 15, at 101-04.

288. See, e.g., Anderson & Menell, *supra* note 99, at 68; Burk & Lemley, *supra* note 16, at 53; Osenga, *supra* note 15, at 90.

289. See *supra* Part I.A.1; see also Cotropia, *supra* note 35, at 83-85.

stages of the patenting process (and rarely amended), when knowledge about how the market will develop and potential competing products is at its lowest, and therefore when the patentee has the greatest incentive to be forthright. The technical context provided in the specification thus is likely to be more reliable and less biased than technical context derived from extrinsic sources selected by the parties, or expert testimony prepared for litigation.<sup>290</sup> It also is readily available to the court and the public at no cost, unlike technical context from extrinsic sources (which would require a competitor *ex ante* to engage in a costly search of all tangentially relevant sources that a biased litigant could rely on later) or expert testimony (which is not accessible or predictable to a competitor *ex ante*).

The technical context provided in the specification is not perfect—patentees have incentives to include broad and ambiguous statements and hide key information about the invention.<sup>291</sup> But patentees must provide at least minimal information about the technical context to comply with the disclosure requirements necessary to obtain a patent. Supplementing this information with additional technical context from extrinsic sources offers only speculative gains and definite costs.

On first pass, the fact that the patent is issued, and the claims approved, by an expert technical agency—the Patent Office—suggests that courts should attempt to replicate the existing technical context in the field of the invention to insure the resulting claim scope reflects that issued by the technically sophisticated Patent Office. However, the Patent Office rules emphasize that claim terms should be understandable just from the patent itself, without resort to extrinsic sources of technical context. They provide that “[t]he meaning of every term used in any of the claims should be apparent from the descriptive portion of the specification with clear disclosure as to its import” and that “terms and phrases used in claims . . . [must] find clear support or antecedent basis in the description so that *the meaning of the terms in the claims may be ascertainable by reference to the description.*”<sup>292</sup> As a result, a patent applicant who adds a new claim term not used in the specification must amend the specification to describe the term.<sup>293</sup> Thus, when a claim construction approach allows extrinsic technical context to vary the meaning that a reader would discern from the patent itself, it fails to show due respect for the expert administrative agency that reviews and issues patent claims.

---

290. Phillips v. AWH Corp., 415 F.3d 1303, 1318 (Fed. Cir. 2005) (en banc).

291. See *supra* Part I.A.1.

292. MPEP, *supra* note 38, § 608.01(o) (emphasis added).

293. *Id.*



### b. Sufficient Information

A related concern is whether the intrinsic record will provide sufficient information with which an ordinary reader could define the claim term. Commentators have noted the “anomalous and surprisingly common situation” where a claim term “appears nowhere in the specification.”<sup>294</sup>

To satisfy the written description and enablement requirements, a patentee presumably will have to describe all major limitations of the claims in the specification, even if using different language. If terminology in the specification is clearly a substitute for a claim term, a court can rely on that to provide the necessary context for construction.<sup>295</sup> Because requiring judges to engage in this additional step increases decision costs, judicial discretion, and the risk of errors, a simpler solution is to vigorously enforce the existing Patent Office regulation that requires patentees to use the same terminology in the specification as the claims. Under this regulation, “the terms and phrases used in the claims must find clear support or antecedent basis in the description so that the meaning of the terms in the claim may be ascertainable by reference to the description.”<sup>296</sup> This requirement can be cheaply enforced during patent prosecution through text searching and a form rejection.<sup>297</sup> It is unclear why this easy-to-police requirement is not always enforced, though it may result from the Federal Circuit’s frequent emphasis on ordinary meaning over contextual meaning.

A more significant problem is that the patentee will use the claim term in the specification, but in a cursory, vague, or ambiguous way. The written description and enablement requirements mitigate this problem, though imperfectly.<sup>298</sup> Better enforcement of the Patent Office regulations could help, since they require that the meaning of the claim term “be ascertainable by reference to the description.”<sup>299</sup> During prosecution, the examiner can reject a claim if the specification does not provide sufficient, or sufficiently clear, information to understand a claim term. Patentees then would have a powerful incentive to provide sufficient information, since an amendment to the specification that is later deemed substantive would render any developments between the filing date and the amendment date prior art that could invalidate the patent.<sup>300</sup> Increased use of the indefiniteness doctrine to invali-

---

294. Menell et al., *supra* note 65, at 720.

295. See *Black & Decker, Inc. v. Robert Bosch Tool Corp.*, 260 F. App’x 284, 288 (Fed. Cir. 2008) (noting that “the specification of the patents here does not use the exact phrase ‘power conversion circuit,’” but looking to similar terms in specification like “power source converter” and “DC/DC converter” to interpret claim term).

296. 37 C.F.R. § 1.75(d)(1) (2013); MPEP, *supra* note 38, § 608.01(o).

297. See MPEP, *supra* note 38 § 608.01(o) ¶ 7.44 (providing text of form rejection).

298. See *Fromer*, *supra* note 37, at 567-68.

299. 37 C.F.R. § 1.75(d)(1); see also MPEP, *supra* note 38, § 608.01(o).

300. See *supra* Part I.A.3.

date patents that fail to use or insufficiently describe claims terms would provide an even more powerful incentive to the patentees.<sup>301</sup>

Potential shortcomings in the context provided by the specification confirm the need to also consult the prosecution history.<sup>302</sup> Because statements in the prosecution history often are made years after filing of the application, they present an increased risk of strategic behavior by the patentee. Thus, courts should be suspect of a patentee relying on the prosecution history in support of a broad claim construction. On the other hand, during prosecution, an examiner's rejection can force the patentee to discuss a particular claim limitation and particular claim terms and explain what those terms mean and why they are different than what is described in the prior art reference relied on by the examiner. The necessity of distinguishing the prior art to overcome a rejection during prosecution can cause the patentee to use a claim term in a far more concrete and informative manner than when talking about the invention in the specification.<sup>303</sup>

### c. Sufficient Guidance

A final concern with an ordinary reader standard is that it provides insufficient guidance to a generalist judge as to how to determine the meaning of a claim term from the intrinsic record.

Arguably, the specification contains technical information that a generalist judge is not well suited to wade through and understand.<sup>304</sup> But history and experience suggest this is not a substantial barrier to claim construction. The Supreme Court and the Federal Circuit's predecessors regularly construed claims based just on the specification and prosecution history, without any reference to the skilled person's perspective or extrinsic evidence.<sup>305</sup>

---

301. See *In re Hammack*, 427 F.2d 1378, 1381-82 (C.C.P.A. 1970) (holding claim indefinite that merely "serv[ed] as 'a shadowy framework' upon which are located words 'lacking in precise referents in the specification' and requiring 'elaborate explanations extraneous to both the specification and the claims'" to construe). Because the claims define the scope of the patentee's rights, they must be sufficiently clear to inform the public of the bounds of the protected invention; claims that are insolubly ambiguous are invalid as indefinite. *Biosig Instruments, Inc. v. Nautilus, Inc.*, 715 F.3d 891, 897-98 (Fed. Cir. 2013).

302. The concerns that cause some to reject reliance on legislative history in statutory interpretation are generally not present with the prosecution history. The prosecution history is collected by the Patent Office into one file and made conveniently available online at no cost. Statements by an individual patentee raise no concerns about identifying collective meaning. And its use raises no concerns analogous to concerns about the constitutional enactment process; to the contrary, granting broader patent scope than that understood by the Patent Office during prosecution raises concerns about the relationship of the Patent Office and courts. See generally WILLIAM N. ESKRIDGE, JR. ET AL., *LEGISLATION AND STATUTORY INTERPRETATION* 236-37 (2nd ed. 2006).

303. Thanks to Oskar Liivak for suggesting this point with me.

304. See *Wagner & Petherbridge*, *supra* note 14, at 143-44.

305. See, e.g., *United States v. Adams*, 383 U.S. 39, 48-49 (1966); *Merrill v. Yeomans*, 94 U.S. 568, 571-73 (1877); *Autogiro Co. of America v. United States*, 384 F.2d 391, 395-14 (Ct. Cl. 1967).

Of course, patents in the Information Age may be more complex than in the Industrial Age. However, patent specifications are not entirely technical disclosures, but rather a mix of legal and technical assertions.<sup>306</sup> Many claim construction disputes turn on the effect of a legal assertion in the specification—for example, the effect of a statement that a feature is part of “the invention,” not “an embodiment”—not the details of the technical disclosure. The judge needs to understand the rules of claim construction, not the technical disclosure, to resolve these disputes.<sup>307</sup>

The judge thus can resolve many claim construction disputes by using basic linguistic canons of construction, such as that terms are used consistently throughout a document, terms are presumed not to be superfluous, and different words have different meanings.<sup>308</sup> The judge does not actually have to define a claim term. Instead, the judge has to resolve a specific dispute between the parties about the proper definition. In many cases, the parties do not dispute the basic definition of a term—*e.g.*, both sides agree that the term “board” refers to a flat piece of building material—but dispute whether the context of the patent provides an additional restriction on the term—*e.g.*, one side argues that the “board” additionally must be made of wood.<sup>309</sup> To resolve these type of disputes where one party argues a term means “X” and the other party argues that patent uses the term to mean “X+Y”, the judge does not necessarily need a detailed knowledge of the technology—instead, she must have knowledge of the rules of claim construction and the linguistic canons of construction. As even Professors Wagner and Petherbridge—critics of contextual meaning—recognize, the task of parsing a legal document for clues about the meaning of terminology used elsewhere in the document is “uniquely lawyerly in nature,”<sup>310</sup> and generalist judges are, of course, trained lawyers.

Admittedly, situations will arise in which it is not entirely clear whether a statement in the specification is defining a claim term or just providing an example, or where the specification uses a claim term broadly in one place and narrowly in another. In many cases, basic interpretive rules and canons will dictate a construction. For example, if the term “board” is used in one place in the specification as referring just to wooden boards and in another place generically without any indication whether it is limited to wooden boards or includes other materials, a construction limiting the term to wooden boards would be consistent with the context. By contrast, if the term

---

306. See *supra* Part I.A.1.

307. If necessary, a judge could use a court-appointed expert to obtain a better understanding of what is being described in the specification.

308. See generally SCALIA & GARNER, *supra* note 96.

309. *Nystrom v. Trex Co.*, 424 F.3d 1136 (Fed. Cir. 2005).

310. See Wagner & Petherbridge, *supra* note 14, at 145 (reaching the counterintuitive conclusion that this “uniquely lawyerly” task is “a relatively poor fit for judges in the modern patent environment”).

“board” is used in one place to refer just to wooden boards and in another place to refer to synthetic boards, the construction of the term “board” must be broader than just wooden boards. Moreover, clarity as to the exact nature of the inquiry also will help avoid difficulties in applying this approach. Probably influenced by the disclosed-invention perspective, contextual meaning approaches in patent claim construction have sometimes suggested a broad use of the specification that only requires a vague “textual hook” in the claims.<sup>311</sup> Under the ordinary reader standard proposed here, however, the specification is used as a dictionary to define a specific claim term and the focus remains on the usage of that term itself.<sup>312</sup>

Professor Golden, who also favors abandoning the skilled person’s perspective, rejected a similar approach to that proposed here because he concluded that the canons of construction upon which such an approach would draw are “often conflicting and indeterminate” and that some specific person’s perspective is necessary to “break ties that the [canons] generate.”<sup>313</sup> This criticism invokes Karl Llewellyn’s famous critique of “dueling” canons of statutory interpretation.<sup>314</sup> Notably, more recent scholarship has questioned the power of Llewellyn’s critique, particularly when it comes to canons reflecting basic rules of syntax or grammar.<sup>315</sup> Regardless of the academic debate, these canons are familiar to judges, who are experienced at reconciling competing canons.<sup>316</sup> Given the extensive textual context provided by the specification, as compared to the comparatively sparse textual context of statutes and contracts, a judge will normally have multiple data points of information, whether textual descriptions or applicable canons, from which to derive meaning in claim construction. In fact, Professor Golden’s primary example of the unworkability of an ordinary reader perspective arises from the conflict between the canons that terms must be construed in light of the specification but limitations cannot be imported into the

---

311. See *Black & Decker, Inc. v. Robert Bosch Tool Corp.*, 260 F. App’x 284, 288 (Fed. Cir. 2008); see also, e.g., *Novartis Corp. v. Teva Pharms. USA, Inc.*, Nos. 04-4473(HAA)(ES), 06-1130(HAA)(ES), 2007 WL 1695689, at \*12 (D.N.J. June 11, 2007) (using claim term “dose” as hook for requirement of “physical separation” that was expressly recited in other claims).

312. See *Autogiro Co. of Am. v. United States*, 384 F.2d 391, 397-98 (Ct. Cl. 1967); see also, e.g., *Lydall Thermal/Acoustical, Inc. v. Federal-Mogul Corp.*, 344 F. App’x 607, 615-16 (Fed. Cir. 2009) (focusing on specification’s use of the term “tufts” to construe claim term “tufts of fiber” as limited by disclosure of specification); *Renishaw PLC v. Marposs Societa’ per Azioni*, 158 F.3d 1243 (Fed. Cir. 2008) (focusing on specification’s use of claim term “when” in describing contact of stylus to limit claim based on specification’s description of time of contact).

313. Golden, *supra* note 72, at 379.

314. Karl N. Llewellyn, *Remarks on the Theory of Appellate Decision and the Rules or Canons about How Statutes are to be Construed*, 3 VAND. L. REV. 395 (1950).

315. See Cass R. Sunstein, *Interpreting Statutes in the Regulatory State*, 103 HARV. L. REV. 405, 451-60 (1989).

316. See *id.* at 452-53.

claims from the specification.<sup>317</sup> As previously explained,<sup>318</sup> the conflict in these canons largely results from the dispute between general and specific meaning. The perspective adopted in this Article—that of an ordinary reader reasoning in the context of the specification—would generally resolve these two canons in favor of the first one.

After application of normal interpretive principles and linguistic canons, indeterminacy undoubtedly will remain in some cases. But criticism of an ordinary reader standard as indeterminate and pointing in conflicting directions is unpersuasive. The indeterminacy critique can only be understood in relative terms—is an ordinary reader approach likely to be more indeterminate than other approaches? Even in situations of conflicting canons or competing descriptions in the specification, the range of possible outcomes under an ordinary reader standard is likely to be quite narrow, normally binary (*e.g.*, this statement either defines the term narrowly or is only an example of a broader definition), and readily apparent from the face of the patent itself. Thus, to resolve whatever indeterminacy remains under the ordinary reader standard, a judge need only grapple with the complexities of the patent specification and accompanying prosecution history.

Other suggested approaches—whether based on the skilled person’s general understanding, a combination of general and specific meaning, the identification of the “actual invention,” or Golden’s “patent attorney with access to the knowledge of an ordinary artisan”—are more complicated, involve more variables, and require consideration of information not apparent from the face of the patent. For example, under Golden’s approach, the judge must not only grapple with the complexities of the patent specification and prosecution history but must additionally reconcile the disclosure of the patent and prosecution history with the background knowledge and understanding of a patent attorney *and* the background knowledge and understanding of a skilled person in the field. The more open-ended and complicated nature of these other approaches provide good reason to think that indeterminacy and conflict will be more frequent, with a wider range of possible outcomes and errors, than under an ordinary reader standard.<sup>319</sup>

### C. *The Ordinary Reader Standard and Claim Construction Values*

Even if an ordinary reader standard is easier and less error prone for generalist judges, the question still remains as to how well it promotes the values thought important in claim construction, primarily predictability and proportionality. There is good reason to think that an ordinary reader standard promotes both of these values as well or better than the competing approaches. An ordinary reader standard thus is desirable regardless of

---

317. Golden, *supra* note 72, at 379.

318. See *supra* Part II.A-B.

319. See Mullally, *supra* note 87, at 368.

whether predictability or proportionality is the more important value for claim construction and offers a way to improve claim construction without resolving this intractable empirical question.<sup>320</sup>

### 1. Predictability

Because conflicting statements in the specification or competing canons of construction will cause indeterminacy in some cases, claim construction will retain a measure of unpredictability under an ordinary reader standard. This unpredictability is likely less problematic than under competing approaches for three reasons, however.

First, because an ordinary reader approach is simpler and involves fewer variables than any of the competing approaches, the range of possible constructions will be less and will normally result in an “either/or” situation (this statement in the specification is defining or is exemplary). Likewise, because the ordinary reader approach limits the inquiry to the public record of the patent and each of the other approaches requires consideration of a skilled person’s (or, for *Golden*, a skilled patent prosecutor’s and a skilled person’s) background understanding and knowledge, the range of options is easier for competitors to identify. The unpredictability of the ordinary reader approach is thus more akin to a “known unknown,” or risk, rather than an “unknown unknown,” or uncertainty. This type of risk is less costly than the uncertainty created by the other approaches because it can be planned for and factored into the cost-benefit analysis when developing a particular product or taking another course of conduct.<sup>321</sup>

Second, predictability turns on whether a competitor can predict how a generalist judge will construe a claim, not just whether the competitor can understand the claim. The other approaches require the judge to take on the counterfactual role of a skilled person or skilled patent prosecutor. Even assuming these inquiries would be fairly easy for a competitor, they are likely to be very difficult for a generalist judge, generating errors. As a result, even if a competitor would be able to understand a claim more easily under another approach, there would be a significant risk that the generalist judge would not adopt this understanding in later litigation. By contrast, even if an ordinary reader inquiry is harder for a competitor, it is more likely to lead the competitor to the same result as the generalist judge.

Third, an ordinary reader standard puts all of the varied consumers of patent claims on equal footing. Using the perspective of a skilled person or a skilled patent prosecutor would require other patent claim consumers to undertake the difficult and costly task of trying to understand the skilled person or prosecutor’s background knowledge and understanding, or risk an erroneous prediction if they failed to do so. Although each consumer will bring his

---

320. See VERMEULE, *supra* note 29, at 82.

321. See Epstein, *supra* note 223, at 969.

or her own background to the interpretive task, they will be united in a common goal—trying to determine, from the objective public record, what the patentee was trying to communicate when it chose a particular term. This task is consistent with normal principles of communication and interpretation,<sup>322</sup> as well as how skilled people are likely to actually read patents.<sup>323</sup>

## 2. Proportionality

Under the ordinary reader standard, a claim term obtains its meaning solely from the description in the patent and prosecution history, thereby promoting proportionality between the resulting claim scope and the patentee's contribution to the field. The important inquiry is whether it does so as well or better than the disclosed-invention approach. Like that approach, the ordinary reader standard carries a risk of both overbreadth and underbreadth, as the court could treat a defining statement in the specification as exemplary or an example as definitional.

In theory, the disclosed-invention approach better achieves proportionality. By definition, the disclosed-invention approach construes the claim to be coextensive with the patentee's "actual invention." By contrast, the ordinary reader approach uses the specification as a dictionary to define a specific claim term. If the patentee simply omitted a key feature of the invention from the claim, the disclosed-invention approach still would creatively tailor the claim language to include this feature, but the ordinary reader approach would not. The relative proportionality benefits of the two approaches thus depend on whether the direct focus on the "actual invention" of the disclosed-invention approach provides sufficiently greater proportionality to outweigh its higher error and decision costs.

There is good reason to think it does not. Situations in which the disclosed-invention approach would offer greater proportionality—where a term or feature is completely omitted from a claim—are likely to be comparatively rare. The complete omission of a claim or feature from the claim is exactly the situation in the resulting broad claim scope would be inconsistent with the disclosure requirements and be invalid. The patentee thus has the incentive not to completely omit a feature or term but rather to describe it broadly or vaguely in the claim. But both the disclosed-invention and the

---

322. See Larry Alexander & Saikrishna Prakash, "Is That English You're Speaking?" *Why Intention Free Interpretation Is an Impossibility*, 41 SAN DIEGO L. REV. 967, 986 (2004); see, e.g., Andrei Marmor, *Textualism in Context 7* (July 18, 2012) (unpublished manuscript), available at [http://papers.ssrn.com/sol3/papers.cfm?abstract\\_id=2112384](http://papers.ssrn.com/sol3/papers.cfm?abstract_id=2112384) (associating interpretation with finding "assertive content," which "is what the speaker actually says by uttering the expression in the particular context of the speech").

323. Technical employees or inexperienced technical experts asked to interpret claims frequently say something like: "I would understand this term to mean X, but I don't think that's how the inventor is using it in this patent. I think they're trying to say Y."

ordinary reader approach would look to the specification to define and limit the broad or vague claim term.

The real question may be about when we want to police proportionality—at the claim construction stage or at the invalidity stage through the disclosure requirements of enablement and written description?<sup>324</sup> Those favoring giving claim terms their general meaning to a skilled person in the field believe that proportionality should be resolved entirely through invalidity, not claim construction.<sup>325</sup> Invalidity alone is likely insufficient to police proportionality. Many overbroad claims will escape invalidation due to the presumption of validity and accompanying clear and convincing evidence standard.<sup>326</sup> Moreover, the disclosure requirements necessitate the notoriously difficult task of proving a negative: that the specification does *not* teach how to make and use the invention or does *not* show the patentee possessed the invention. Finally, hindsight bias makes it less likely that overbroad claims will be invalidated through the enablement or written description doctrines, as subsequent developments in technology are likely to make the invention seem easier to build than it was at the time.<sup>327</sup>

By contrast, the disclosed-invention approach places the entire burden of policing proportionality on claim construction, since claims that are construed to be limited to the “actual invention” disclosed in the specification will almost certainly satisfy the enablement and written description requirements. In fact, this approach may be motivated by dissatisfaction with the inadequacies in enablement and written description in policing overbreadth. This heavy emphasis on proportionality in claim construction greatly increases the difficulty, costs, and errors of claim construction.

The ordinary reader approach described in this Article steers a middle ground between these two extremes. It gives claim construction a primary, but not exclusive, role in insuring proportionality, while making claim construction simpler and cheaper. The ordinary reader standard is likely to do a sufficient job of policing proportionality for most patents, with only the most egregious examples of disproportionality—such as the complete omission of a key feature from the claim—surviving claim construction. These are exactly the type of cases that warrant the more costly efforts necessary to ensure complete proportionality through the written description and enablement requirements. Despite their shortcomings, the disclosure requirements are likely to be most effective at policing overbreadth when a key feature of the invention has been completely omitted from the claim, rather than just vaguely or broadly described.

---

324. Thanks to Jonathan Masur for raising this point with me.

325. *Retractable Techs., Inc. v. Becton, Dickinson & Co.*, 659 F.3d 1369, 1371 (Moore, J., dissenting from the denial of the petition for rehearing en banc).

326. See 35 U.S.C. § 282(a) (2012).

327. See Mandel, *supra* note 200, at 1442 (discussing enablement).



### CONCLUSION

Claim construction is hard. “Things are not made for the sake of words, but words for things.”<sup>328</sup> The inherent difficulty in claim construction naturally causes judges and scholars to search for ways to improve this task. But, in doing so, there is great temptation to focus on idealized theorizing without giving sufficient consideration to the capacities and performance of the generalist judges who must implement claim construction. That which is simple in theory often is difficult in practice.

Each of the major approaches to claim construction—the focus on general meaning, the attempt to reconcile general and specific meaning, and the focus on the disclosed invention—presume that judges can easily implement the preferred approach. Careful consideration of these approaches suggests the opposite. These inquiries are open-ended, involve many variables, and require the judge to undertake the counterfactual role of a scientist. The result is likely to be significant errors and costs.

To reduce errors and costs, the judge should be assigned the familiar task of determining how an ordinary reader would understand the claim term, based just on its substantive and linguistic usage in the patent and prosecution history. Although some indeterminacy will remain in claim construction, there is little reason to think that more information or a more complicated approach will offer a significant enough improvement to warrant its costs. An ordinary reader standard may seem inconsistent on first glance with basic principles of patent law, but it actually promotes consistency with the relevant technical context and accurately reflects the varied modern consumers of patent claims.

---

328. *Autogiro Co. of Am. v. United States*, 384 F.2d 391, 397 (Ct. Cl. 1967).