

Regis University ePublications at Regis University

All Regis University Theses

Spring 2011

Service Delivery Utilizing Wireless Technology Within The Air Traffic Control Communication And Navigation Domain To Improve Positioning Awareness

Samuel Durbin
Regis University

Follow this and additional works at: <https://epublications.regis.edu/theses>

 Part of the [Computer Sciences Commons](#)

Recommended Citation

Durbin, Samuel, "Service Delivery Utilizing Wireless Technology Within The Air Traffic Control Communication And Navigation Domain To Improve Positioning Awareness" (2011). *All Regis University Theses*. 740.
<https://epublications.regis.edu/theses/740>

This Thesis - Open Access is brought to you for free and open access by ePublications at Regis University. It has been accepted for inclusion in All Regis University Theses by an authorized administrator of ePublications at Regis University. For more information, please contact epublications@regis.edu.

Regis University
College for Professional Studies Graduate Programs
Final Project/Thesis

Disclaimer

Use of the materials available in the Regis University Thesis Collection ("Collection") is limited and restricted to those users who agree to comply with the following terms of use. Regis University reserves the right to deny access to the Collection to any person who violates these terms of use or who seeks to or does alter, avoid or supersede the functional conditions, restrictions and limitations of the Collection.

The site may be used only for lawful purposes. The user is solely responsible for knowing and adhering to any and all applicable laws, rules, and regulations relating or pertaining to use of the Collection.

All content in this Collection is owned by and subject to the exclusive control of Regis University and the authors of the materials. It is available only for research purposes and may not be used in violation of copyright laws or for unlawful purposes. The materials may not be downloaded in whole or in part without permission of the copyright holder or as otherwise authorized in the "fair use" standards of the U.S. copyright laws and regulations.

**SERVICE DELIVERY UTILIZING WIRELESS TECHNOLOGY WITHIN THE AIR
TRAFFIC CONTROL COMMUNICATION AND NAVIGATION DOMAIN TO
IMPROVE POSITIONING AWARENESS**

A THESIS

SUBMITTED ON 12TH OF APRIL, 2011

TO THE DEPARTMENT OF COMPUTER AND INFORMATION SCIENCES

OF THE SCHOOL OF COMPUTER & INFORMATION SCIENCES

OF REGIS UNIVERSITY

IN PARTIAL FULFILLMENT OF THE REQUIREMENTS OF MASTER OF SCIENCE IN

SYSTEMS ENGINEERING

BY



Samuel Durbin

APPROVALS

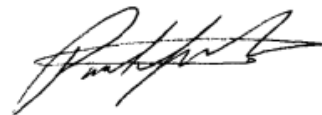

Paul Vieira, Thesis Advisor

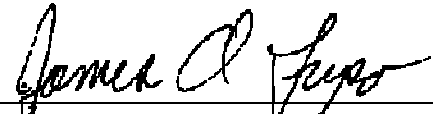

James A. Lupo

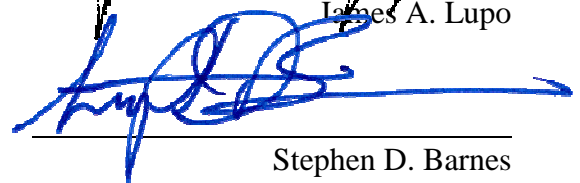

Stephen D. Barnes

Abstract

Current air traffic levels around the world have pushed the enterprise architecture deployed to support air traffic management to the breaking point. Technology limitations prevent expansion of the current solutions to handle rising utilization levels without adopting radically different information delivery approaches. Meanwhile, an architectural transition would present the opportunity to support business and safety requirements that are not currently addressable. The purpose of this research paper is to create a framework for more effectively sharing positioning information utilizing improved air traffic control navigation and communication systems.

Table of Contents

ABSTRACT	ii
LIST OF FIGURES	vi
LIST OF TABLES	viii
Chapter	
I INTRODUCTION	1
Statement of the Problem	2
Statement of Goals and Objectives	3
II REVIEW OF LITERATURE & RESEARCH	4
Service Efficiency Requirements	4
System Wide Information	6
Carrier Limitation and Saturation	7
Safety Limitations	15
ASPIRE Methodologies	19
APU Reduction	20
Just in Time Fueling	22
Requirements for Unified Architecture	24
Complications	25
Equipment Age	25
Labor Relations	26
Future Transmission Mediums	27
802.11	27
802.16e	28

802.21	30
Current Architecture	31
Framework Components	31
Communications	32
Navigational Aids	33
Phases of Flight	35
III METHODOLOGY	37
User Traffic Study	37
Current Service Framework Definition	38
Future Service Framework Development	38
IV PROJECT ANALYSIS & RESULTS	40
User Traffic Study	40
Definition of the Current Service Framework	43
Voice	43
VHF	43
Public Safety	45
Data	46
Location Information	47
Definition of the Future Service Framework	48
Voice	48
Location	51
Data	53
Refinement of the Future Service Framework	55

802.16e Service Framework	55
User Segment Bandwidth Estimation	61
802.16e Backhaul Framework	63
V CONCLUSIONS	67
REFERENCES	73
BIBLIOGRAPHY	78
ACRONYMS	96
GLOSSARY	100

List of Figures

Figure		Page
1	Expected Carrier Limitation and Saturation Points	8
2	Infrastructure Technology Results from Phase Three	14
3	Transitional Boundaries Based on Velocity and Data Rate	31
4	Navigational Architectural Domains	34
5	Phases of Flight	35
6	Correlation of Information Availability and Phases of Flight	41
7	Wireless Delivery Segments and Control Boundaries	42
8	Hourly Peak Instantaneous Aircraft Count	43
9	Example of the VHF Voice Communications Infrastructure.	45
10	Logical Example of VHF and IP Boundary	49
11	Example of Voice Stream Mixing and Virtual Talk Groups	51
12	802.16e Fundamental Wireless Framework Qualities	56
13	Calculation of the VHF VTG User Segment Bandwidth	57
14	Calculation of the P34 VTG User Segment Bandwidth	58
15	Calculation of the Positioning Solution User Segment Bandwidth	59
16	Calculation of the ATS Data User Segment Bandwidth	60
17	Calculation of Security Overhead for the User Segment	61
18	Example of 802.16e Fractional Frequency Reuse	62
19	Calculation of VTG Backhaul Segment Bandwidth	63
20	Calculation of IP Data for Backhaul Segment Bandwidth	64
21	Calculation of Security Overhead for the Backhaul Segment	65

22	Service Framework Segmentation Boundary	68
23	Extension of the Wireless Domain to Include 802.11 Technology	69
24	The Wireless Domain with 802.11 and Satellite Technology	70
25	Service Framework Supporting System Wide Information	71

List of Tables

Table		Page
1	Phase Two Considerations for Technology Replacement	12
2	Phase Three Considerations for Technology Replacement	13
3	Possible Services Delivered Via the 802.11 Segment	28
4	Primary VHF Channel Assignments	44
5	Proposed TIA-902/P34 Public Radio Bandwidth Requirements.	46
6	Common VDL Channel Assignments	47
7	10-MHz Channel Data Rates Utilizing 33% Fractional Frequencies	62
8	10-MHz Channel Data Rates without Fractional Frequency Reuse	65

Chapter 1 – Introduction

The National Airspace System (NAS) is an umbrella of isolated systems that deliver information collectively utilized for the management of aircraft operating within airspace controlled by the United States Government. Rather than a net-centric architecture, the NAS has evolved into a human-centric system that relies on multiple layers of complicated human-computer interaction models to successfully operate (Ashby, 2003). The sophistication and pace of these interactions has changed the air traffic management environment into a workplace notorious for a high-stress operational tempo.

The massive personnel costs to maintain and operate the systems are an indicating factor that the current architecture is defunct. Nearly 75% of the operational budgets during 2007 and 2008 were solely attributed to staff costs for normal operation (Eftekari, 2005). High labor costs and inefficient systems highlight the opportunity to achieve greater efficiency through modernization. While such gains could be construed to be to reduce labor requirements, they should instead be applied to increasing the operational capacity of the NAS.

Experts from the Federal Aviation Administration (FAA) and National Aeronautics and Space Administration (NASA) realized that the capacity of the NAS would require momentous improvement to meet future demands. The most substantial of these requirements is the responsibility of the air traffic management authority to maintain a safe operational airspace. Additionally, efficiency through safe operations will significantly contribute to the reaching the FAA goal of achieving a 95% on-time rate for all domestic flights.

In order to reach these efficiency goals while maintaining established safety requirements, massive restructuring of the NAS architecture is required. In 2003, the three major parties responsible for managing the NAS began researching alternative technology solutions

(Hughes, 2004). The FAA, NASA, and the Department of Defense (DoD) formulated a joint recommendation for the major components of this solution that collectively became known as NextGEN.

Statement of the Problem

Airline travel has experienced a tremendous increase in popularity over the past two decades, bringing incredible strain on the air traffic management infrastructure. In the United States, keeping pace with this explosive growth has proven incredibly difficult during periods of expansion. Failing to address these capacity issues through modernization efforts not only has significant impact on safety, but threatens economic stability in some regions (Burbank & Kasch, 2006).

The current NAS was essentially established on contractor delivered systems that were deployed during the 1960's (Burbank & Kasch, 2006). Rather than delivering an information centric architecture that is common in many current enterprises, NAS systems are typically human centric. This complex system prohibits a significant amount of interoperability at the system level and many of the subsystems are not fit for purpose when considering integration into modern communication systems.

Not only does the current architecture not offer clear migration paths, the infrastructure shows incredible signs of stress. The infrastructure operations and maintenance budget for the NAS as of 2005 was roughly \$2 billion annually (Eftekari, 2005). Under these conditions, the pressure to migrate the current architecture to a modern solution thereby increasing capacity, offering sensible migration paths utilizing current technology, and reducing operational costs are significant.

Statement of Goals and Objectives

The increased interrelation between these systems under the NextGEN architecture provides increased opportunities for addressing safety and efficiency shortfalls not previously possible. One of the most significant concerns under the current architecture is the collision of two aircraft on the airport surface. The root causes that contribute to such possibilities are the fractured structure of the architecture and the lack of service continuity that can be provided under such conditions.

More accurately, the current system lacks the functionality to share positioning information between all users and correlate that information with communication solutions in a meaningful way. Considering the size of the NAS and the collaboration required in the target workspace, the final solution must be scalable and easily reproducible. The purpose of this paper is to develop a service framework that can address these concerns by utilizing components of NextGEN modernization efforts to improve airfield safety.

Chapter 2 – Review of Literature and Research

Service Efficiency Requirements

While safety is of the utmost importance in the aviation industry, all enterprise architecture projects serve a diverse group of stakeholders. The capital expenditures required for NAS modernization are expected to produce an efficient operating environment that is capable of improving profitability. Like most other business activities, the aviation industry is largely driven by time and the cost of fuel. Utilizing the information provided through decision support systems to make profit producing activities less time consuming and more fuel efficient is a direct way to reach the goal of increased viability in the industry.

The most likely time when an aircraft is going to be idle or utilizing excess fuel is when on the ground during arrival or departure phases. Aircraft are commonly operated in these phases for a less than optimal time during periods of congestion or when waiting for activities to be completed by others. The state of outdated systems utilized to support decision making do not currently facilitated the desired processes that could optimize these operations.

The architectural vision for NAS modernization is driven by the goal to increase the number of on time flights. Barring the availability of a better methodology, the current architecture services users following a first come, first served basis. Utilizing this approach, an aircraft is entitled to departure, arrival, or airspace largely based on order of arrival rather than their ability to make the most efficient use of the asset. The detrimental effects of these conditions cause serious limitations at the airport surface.

Since time is limited asset in the aviation industry, access to limited airport resources can have far reaching effects on the operational environment. If a user cannot maintain a certain level of performance such as a departure time, controllers must manipulate conditions in an attempt to

utilize departure times in the most efficient manner possible. Considering the lack of computational ability within the current architecture, the labor of completing this activity may be less beneficial for the controller than the perceived impact.

Offloading this mundane computational requirement from the human computer interaction environment to the technology architecture enables more efficient utilization of access for the good of the user environment as a whole. Although the output of one transaction may seem insignificant, the impact of numerous users across the architecture utilizing a disproportionate level of resources produces a profound effect. . The primary requirement to support an improved decision making process is more robust communication of user location at the airport surface.

More effective location supports a clear decision making process involving factors tied to user performance. As user performance can contribute to remarkable delays throughout the architecture, effective positioning must correlate location and performance information to mitigate user impacts on the ground. This outcome supports the business case to provide access to users when they meet established performance requirements. (Sherry, Feary, & Medina, 2009).

Furthermore, changing operating conditions effect user groups differently and make performance prediction difficult. For example, weather is the largest single factor that disturbs NAS capacity yet not all aircraft are affected at the same rate. This enhanced location information would support the categorization of users based on performance rather than order of arrival or preparation for departure.

Rather than unequivocally controlling aircraft based on conditions alone, other factors such as performance of the aircraft class could be considered before the airspace utilization is

discontinued due to weather (Sherry et al., 2009). Decisions could be made on the ground to utilizing the airspace based on these factors and reduced utilization of airspace could continue. The net result could be greater utilization of airspace with more responsive routing management; however, this information is nearly impossible to correlate utilizing the current service framework.

System Wide Information

One of the core efficiency detractors within the NAS is the inability to make information from the airport surface available throughout the enterprise. Although business purpose is unified behind efficient operation, feasible and cost-effective infrastructure has limited the continuity of the technology architecture. One of the primary goals of NAS modernization at the airport surface is unification the transmission infrastructure to extend information delivery capacity throughout the operating environment.

The operating environment is currently limited by continuity of information availability can provide as users move through the network. Information sharing is further suppressed since information continuity between users connected to different segments of the technology architecture requires human computer interaction from a non-user who acts as an intermediary. The inefficient manner of information sharing at the airport surface could significantly benefit from improvement by automating the information sharing throughout the architecture.

Meanwhile, events that happen beyond the airport surface are unlikely to be available to support the decision making process. This extreme limitation fragments situational awareness to the user's current segment while hampering the immediate return on investment from trend analysis (Lockheed Martin Corporation [Lockheed], 2008). While one transport layer technology

is not likely to serve the entire architecture, the adoption of IP capable carriers with the information carrying capability required to unify the architecture will provide substantial benefit.

To support this capability, the technologies chosen to replace the physical layers at the airport surface must be capable of presenting information beyond the localized bounds. Users will have greater information demands while requiring synchronous updates to support enhanced situational awareness. Considering that many events effecting situational awareness will occur beyond the airport surface requires consideration during bandwidth prediction to receive the maximum benefit and guarantee future utilization of the solution.

Additionally, the migration path of the current technology architecture imposes significant limitation on information sharing due to the high dependence on legacy systems (Lockheed, 2008). Unifying surface communication with the overarching technology architecture simplifies future operation and initiates an operational shift from reactive to predictive operation. Similarly, fabric unification integrates users throughout the network into a focused business system (Mitchell, 2006). This thesis must produce a framework that will ensure that stakeholder needs are met by supporting service delivery throughout the domain.

Carrier Limitation and Saturation

The principal NAS technology constraint is the saturation of RF carriers utilized to manage traffic on the ground and beyond. The three primary technologies currently utilized are Very High Frequency (VHF) for voice communications, VHF Air Traffic Service (ATS) for data communications, and 1090 Extended Squitter (1090ES) for transmitting positioning data. While saturation is not a universal phenomenon, several larger airports in the US are unable to issue additional frequency assignments (Nolan, 2004).

Although these limitations may not be experienced throughout the architecture, increasing traffic levels will push the requirements for these resources to their limits in the near future. The legacy technologies that are the bedrock of the NAS infrastructure have a limited ability to support expanded user requirements. The three primary carriers involved in the process of locating and managing aircraft traffic with their projected limitation and saturation points are found in Figure 1 (Efekari, 2005).

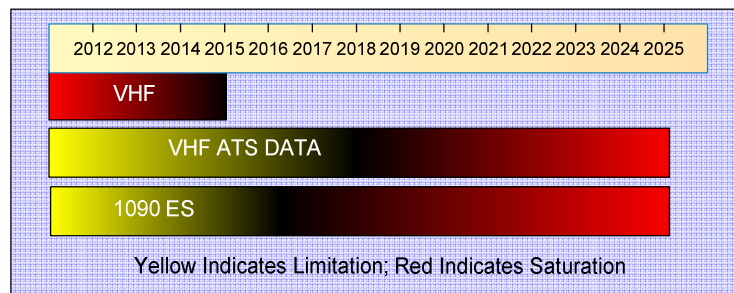

Figure 1. Expected Carrier Limitation and Saturation Points.

In addition to the likely saturation of the VHF ATS Data spectrum, securing the band has proven difficult. Many modern cryptology methods exceed the bandwidth for the underlying ATS data requirement, leaving insufficient bandwidth remaining to support such measures (Ivancic, 2006). Such limitations prevent the integration of VHF ATS data solutions into future architecture since security solutions cannot be applied uniformly throughout the technology domain.

The current best effort security measure applied to VHF ATS is security through obscurity (Ivancic, 2006). Although this method has been previously effective for this deployment, it is unlikely that this will remain the status quo in a converged environment. In all likelihood, this shortcoming could become a breach point for a potential attacker into the IP environment. Addressing the deployment of the technology architecture of segments adjacent to

the VHF ATS segment will require special attention to ensure that this deficit does not present an opportunity to a prospective aggressor.

In addition to ensuring that security shortfalls are met, deploying viable solutions is especially important. The technology architecture development must consider that the segments will be developed to integrate solutions supporting users moving between different business segments. While a majority of these business segments are confined to the US, stakeholder groups throughout the world have significant interest in how the technology domain will support their business segments.

Due to this diverse stakeholder group, the approach of cryptography and security applications should be approached from the overall architectural vision rather than an isolated technology segment development. The laws governing the development and deployment of encryption devices vary when crossing national boundaries that the new architecture will transverse. One of the most restrictive legislative directives that will affect the architectural defense approach are International Traffic in Arms Regulations (ITAR) (Ivancic, 2006). For this reason, the technology architecture should be free from devices or technology that is restricted by this and other legislation.

Not only are current technologies limiting the growth and stability of the architecture, the possibility of evolution is restricted by the massive resources required to support the transitional architecture phases. Bearing in mind the diverse stakeholder groups involved in developing standards for the technology infrastructure, the time required to reach a consensus between authorities regarding feasible solutions could be considered less than ideal. Consensus was finally reached, but execution of solutions based on Air Navigation Conference 11 (ANC/11)

directives and development of Action Plan 17 (AP-17) require significant study, collaboration, and development.

Even when concentrating on an isolated scope of the NAS such as the communications infrastructure in question, the implications of migration are still massive due to the mobility of the users through the architecture. The large number of devices that must be resourced to support the technology infrastructure are a key factor to adoption. Although phased introduction is a likely scenario, industry support to produce the required components is vital for success.

Although AP-17 outlined a preliminary solution, a full commercial off the shelf solution is not expected to support the complete technology architecture (Pouzet, 2007). This approach will require that vendors are involved to develop specialized solutions based on needs assessments. Involvement of these material providers will be a key prerequisite for meeting supply chain requirements during transition architecture deployments. If such industry involvement is not garnered, meeting transition timelines will be difficult and frustrate budget planning for reaching the target architecture.

The obligation to carefully evaluate replacement technology required the execution of a highly detailed multistep evaluation program. Technology prescreening for replacing aeronautical ground to air VHF channels was directed in AP-17 as task 3.1. The ICAO established the Aeronautical Communications Panel (ACP) to facilitate a common global solution through utilizing inputs from joint FAA and Eurocontrol research (Brudinger, Dyer, & Bruno, 2005). Although the aforementioned agencies conducted a significant amount of research with the support of NASA, the initial undertaking of the ICAO panel was to prescreen technologies in an effort to synchronize development.

The primary search factor was to identify a product that was properly positioned in its life cycle to support the technology architecture requirements and meet the organization's transitional requirements. Technologies that were strictly proprietary were not considered when an open standard equivalent was available (Brudinger et al., 2005). Utilizing a proprietary technology for development of architecture of this size could cause vendor lock that would restrict the supply channel.

Utilization of open source platforms permits a wider audience of researchers to develop solutions for the target architecture and ensures better integration of the final product. Secondly, immature technologies were eliminated if more mature solutions in the same family were available for consideration (Brudinger et al., 2005). Immaturity presents significant possibility that a technology will not deliver the capability required to support the surface communications. Requirements for interoperability and stability of a new technology are better developed further into a product's lifecycle while delivering more predictable performance.

Finally, technologies that were judged to be near their expected end of life were not considered for adoption (Brudinger et al., 2005). Lack of vendor support for the primary technology will prevent delivery of portions of the transitional architecture and ultimately the desired solution. Moreover, new solutions are unlikely to find the support required for development relying on an underlying solution that is no longer supported by a significant manufacturer base.

Following the initial thinning of the solution pool, four fundamental areas of concern were identified for consideration of the solutions that remained during phase two. Refinement of the solution search continued through more strict limitations outlined for phase two of AP-17

task 3.1. These concerns and discussion points as presented by the initial researchers who developed the limits are found in Table 1 (Brudinger et al., 2005).

Communications Capabilities	Technology has the capability to support current and anticipated requirement	Support for Voice Requirements
		Support for Datalink Requirements
		Support for Enhanced Datalink Requirements
Maturity	Technological Maturity in conjunction with the ability of the technology to assure safe operation in the aeronautical environment	Readiness Level
		Standardization
		Certification
Cost	Infrastructure cost for avionics systems and service provider	Infrastructure
		Avionics
Additional Factors	Further considerations not otherwise categorized	Spectrum Protection
		Security
		Transition

Table 1. Phase Two Considerations for Technology Replacement

Phase three was an incredibly detailed technology investigation based on principles similar to the previous stage (Brudinger et al., 2005). However, the evaluation criteria were expanded to create a more comprehensive study of the technologies in question. The goal of this exhaustive research was to create a short list of viable technologies to support the infrastructure required for the new architecture rather than describe their final purpose and utilization.

In addition, not all criteria from phase two directly correlate to those found in phase three to permit further tailoring of the technology architecture requirements. To further delineate the importance of the evaluation factors, the outcome was weighted to reflect the importance of each criterion. The identification of each criterion and the importance as ranked by the researchers can be found in Table 2 (Brudinger et al., 2005).

Most Important	Spectrum	
	Provide Air Traffic Service Air to Ground Data	Capacity
		Peak Instantaneous Aircraft Count (PIAC)
		QoS
		Environment
Very Important	Technical Readiness Level	
	Ground Infrastructure Cost	
	Avionics Cost	
	Provide Future Air Traffic Service Air to Ground Data	Capacity
		Peak Instantaneous Aircraft Count (PIAC)
QoS		
Environment		
Important	Standardization Status	
	Certification	
	Authentication and Integrity	
	Robustness to Interference	
	Transition	

Table 2. Phase Two Considerations for Technology Replacement

Spectrum viability and performance became the most important factors during the final phase of research based on the fundamental requirement to reach the future architecture. Factors rated as very important focused on ensuring the stability and performance required to deliver the expected longevity. Finally, factors rated as important relate to the likelihood that the technology will be successfully adopted by the organization although it may be a practical solution.

The solutions required to support the technology architecture differ based on the operating environments found throughout the world. Although the architecture must support uniform service levels for roaming subscribers, the unique business domains necessitate some differentiation to tailor service delivery. Although some technologies are common to both domains, they delivery may differ slightly. The phase three research results became the basis for the communications infrastructure development and can be found in Figure 2.

	Common to US & European Airspace	Unique to European Airspace
Continental Airspace	<ul style="list-style-type: none"> • TIA 902 (P34) • LDL • W-CDMA 	<ul style="list-style-type: none"> • B-AMC • AMACS • Custom Satellite
Oceanic / Remote Airspace	<ul style="list-style-type: none"> • Inmarsat SBB • Custom Satellite 	
Airport	<ul style="list-style-type: none"> • IEEE 802-16e 	

Figure 2. Infrastructure Technology Results from Phase Three.

The impact of these recommendations on surface communications is the desire to pursue 802.16 technologies for airport surface communication, the lack of support for 802.11 technologies for enterprise solutions, and the retention of the P34 infrastructure. After considering the performance of the band and the status of the current standard, the FCS members recommended to the IEEE that an unused portion of the C-band be reserved for Aeronautical WiMAX applications (Gilbert & Budinger, 2007). The framework produced by this thesis must consider these limitations to produce a solution that is compliant with these margins.

Further technology architecture recommendations were made to supplement 802.16 deployments with aeronautical satellite communication systems (Gilbert & Budinger, 2007). Although the 802 family of technologies is well suited to provide services at the airport surface, the FCS recognized that complementary technologies would be required to support a robust infrastructure. One of the products of this thesis will be to define a boundary and control mechanism between these fabrics to ensure consistent service delivery.

Considering support for WLAN utilization at the airport surface, this thesis will present a boundary which can be utilized to demark 802.11 services. This is important to create a framework that will be compliant with desires by other stakeholder groups to utilize this technology within the architecture. Additionally, this demarcation is important to mark the end of service that will be officially required for service delivery agreements.

While the P34 infrastructure is a component of the continental airspace technology, the FCS has recommended that an IP point of attachment be developed. This service should be delivered at the airport surface to ensure session continuity as the user moves throughout the architecture. Furthermore, this service will have transitional points of attachment to the P34 infrastructure or other IP frameworks.

The framework developed by this thesis will focus on the identification of appropriate IP compatible replacements for those currently offered through the carriers identified for convergence. This development will include ensuring that the migratory paths are aligned with the goal of streamlining human computer interaction at the airport surface. Moreover, this framework will be validated by a case study to ensure that the chosen solutions are viable by utilizing a sample user traffic pattern.

Safety Limitations

The capacity of voice and data carriers directly correlates to an airport's capacity to manage aircraft within their area of responsibility. Saturation of a specific carrier within an airport's area of responsibility marks the point at which no more traffic may be effectively managed. However, considering the human centric nature of the current safe operation may be significantly inhibited in a congested environment well before technology saturation.

Many NAS subsystems rely on human interaction to interpret and deliver information to other users. This shortage of predictive computational ability requires that the limitations imposed by the human component of the architecture are strictly followed to avoid exceeding computational capacity. The cognitive capacity of air traffic managers is directly applied to interpret and manage airspace contention to avoid collisions.

As the congestion of a controller's airspace increases, procedural separations must be implemented to maintain the same number of aircraft in their assigned space (Nolan, 2004). Space fluctuations in conjunction with the specialized cognitive skills required for communicating and interpreting positioning information between the controller and pilot occasionally contributes to misunderstanding. These misunderstandings can surface in the form of incorrect positioning information being conveyed and result in incorrect guidance in reply.

The result of this incorrect information exchange can result in an aircraft inadvertently entering the path of another aircraft. This type of airfield incident is referred to as an incursion, regardless if there is actual contact of the aircraft that have crossed paths (Nolan, 2004). Although incursions that do not result in a collision may not be reported under FAA rules, NASA maintains an anonymous database where aerospace professionals can report incidents without reprisal.

Incidents reported to NASA's Aviation Safety Reporting System (ASRS) are examined to perform root cause analysis and determine industry trends. The cumulative data is utilized to develop future policies and prevent patterns of incidents attributable to a manageable number of preventable causes. In 2006, the deadliest runway incursion in the U.S. occurred at Lexington, Kentucky when Comair Flight 5191 attempted to takeoff from the wrong runway (National

Transportation Safety Board [NTSB], 2006). During the month of July 2010 alone, there were three incursions reported in the United States that did not result in collisions.

More extensive searches reveal that the identified cause for the most recent ten events can be attributed to communication breakdown, inadequate situational awareness, or other human factors (Aviation Safety Reporting System, 2010). Irrespective of the findings, the condition of the technology architecture is the key underlying factor contributing to the incidents.

Redesigning the human computer interaction by delivering information through the NextGEN architecture is a fundamental progression to reducing or eliminating these types of incidents.

In fact, the National Transportation Safety Board (NTSB) has been concerned about the possibility that a taxiway or runway incursion could lead to a catastrophic incident for some time. In 1977, the deadliest incident in aviation history occurred at Tenerife, Canary Islands in which 583 lives were lost. During the incident, two aircraft operated by different carriers simultaneously proceeded to take off on the same runway in different directions. Although this catastrophe occurred outside the United States, it became the watershed event for airfield positional awareness.

Investigators concluded that two central factors contributing to the incident were poor visibility on the airfield due to fog and simultaneous voice communications that were not properly acknowledged (Grela, 1978). While the NTSB has listed the topic of runway safety as one of their most wanted safety improvements since 2000, these factors remain difficult to completely eliminate utilizing the current architecture (National Transportation Safety Board [NTSB], n.d.). The state of these factors still being a relevant part of the architecture could have tragic effects.

Ground controllers currently ensure that they are directing the correct aircraft through utilization of airport surface radar, visual observation, or aircraft crew confirmation. Although these methods are effective under most conditions, the possibility of incursion under all conditions cannot be effectively mitigated. In addition to the notable communication hurdles, airfield surface radar may have limited capability and does not provide a service directly to the air crew.

This shortfall fails to meet the NTSB requirement that aircrews are warned of crossing a runway before proceeding without requiring human intervention. Utilizing this technology, the radar is monitored by the ground controller who is also responsible for executing predictive computation. Relying on the controller alone to execute this task fails to meet the NextGEN architectural goals by providing predictive computational availability that is not currently available within the architecture.

Secondly, aircrew confirmation of position can be of limited reliability considering the human factors involved in one transaction. Variables involved with language and skill can significantly complicate the transmission and understanding of meaning. A significant number of aviation related incidents are attributed to human factors, many of which are subject to poor communication.

Finally, visual observation of aircraft has significant limitations when directing aircraft on the airfield. Although situational awareness is vital to limiting factors that contribute to safety incidents, visual acuity is not infallible as a service. Instead, visual identification of location and associated terrain should be a tertiary factor that is supported by a properly constructed decision support system to augment positional awareness.

Current aircraft have been engineered to deliver a noteworthy level of computing ability in an ergonomic fashion to support efficient operation (Knight, 2007). Significant studies have shown that increased information delivery increases safety without overburdening the crew to make them aware of potentially tragic conditions (Kramer & Busquets, May 2000). Architectural modifications during the NextGEN modernization present a significant opportunity to deliver converged services to the cockpit that are required for expanded services.

Procedures have been updated to mitigate tragedy, yet the current technology architecture does not support expanded capability mandated by NTSB requirements. Although the FAA has responded to the NTSB requirement to improve airfield safety five times, the NTSB has commented that the only acceptable response is to install moving map technology (NTSB, n.d.). While the business architecture requirements are well established, the availability of an IP infrastructure presents a significant opportunity to complete the technology architecture that is currently deficient.

One of the primary goals of this thesis is to deliver a framework that can support a more streamlined human computer interaction model. By delivering increased positioning information, air crew situational awareness could significantly increase by eliminating the requirement for a verbal request and response for information from the controller. The desire for this service is evidenced by the NTSB concurrence that moving map information in the cockpit would significantly increase airfield safety.

ASPIRE Methodologies

One of the primary acceptance criteria of any technology architecture component is its capacity to support a justifiable business case. While the business architecture for NextGEN presents multifaceted challenges, the opportunities to increase efficiency are tremendous.

Though providing immediate aircraft positioning may seem trivial from a business perspective, the economy of scale when applied to resource preservation or time management has proven to be incredible.

The employment of multiple legacy systems presents a disorganized operating picture for system users that leads to uncertainty and inefficiency (Lockheed, 2008). Under the constraints of legacy systems, acceptable parameters for the business requirement validation must be widened to ensure interoperability. In the commercial airline industry, this is evident by aircraft staying in the ready position for a longer period of time to meet departure times governed by air traffic management factors.

Time uncertainty contributes to increased passenger delays and inherent airline costs. Considering the architectural vision for increasing on time flights and ensuring cost effective operations, the mechanics of aircraft location and the associated business case must be considered to ensure congruence with the target architecture. The basis of a business case has already been researched and presented by the Asia and South Pacific Initiative to Reduce Emissions (ASPIRE).

APU Reduction

Auxiliary Power Units (APUs) are turbine or reciprocating engines that are utilized to power generators, hydraulics, and air pumps on aircraft when the main engines are not in operation (Crane, 2007). The most common state when the aircraft APU is running under normal conditions is when the aircraft is at the gate in the waiting position. According to common industry practices, the airline is responsible for operations at the gate until directed by the ground controller to enter the taxiway.

The functions powered by the APU can be provided by the airport in a much more energy efficient manner. However, time uncertainties require that the aircraft is detached from these support services and prepared for departure in advance of the time required by the ground controller. During the time between service elimination from the gate and main engine start, the APU must provide complete functionality.

The greater the positional uncertainty or load on the ground controller to perform predictive calculations, the more ambiguity there will be between planned and actual aircraft taxi times. Therefore, the aircraft will rely on APU power for a longer time to ensure that the aircraft is in the ready position to meet the departure time.

Introduction of definitive positional accuracy on the airport surface permits the streamlined delivery of taxi times to support the ASPIRE methodology to minimize APU utilization. Positioning accuracy enhanced by improve surface communications and predictive computational ability will provide dynamic crew preparatory time prior to airport taxi times. This can minimize the time between airport service elimination and main engine start to reduce aircraft fuel consumption.

The ASPIRE study focused on two primary aircraft types, the Boeing 777 (B777) and Boeing 747 (B747). The B777 utilizes approximately 60 gallons per hour while the B747 utilizes approximately 110 gallons per hour. ASPIRE implemented a human controlled system that saves approximately 60 gallons of fuel per flight at New Zealand's Auckland airport (Asia and South Pacific Initiative to Reduce Emissions [ASPIRE], n.d.) While this methodology is operated by a human in its current configuration, significant enhancement can be gained through technology architecture modernization.

It is important to note that the Auckland airport pursued a special initiative as part of their business architecture to ensure that APU replacement services were available at the gate. Supporting the scalability to support revolutionary services such as this while meeting the target architecture and maintaining configuration management of the technology segments is an important design factor. Additionally, configuration management requires that a service is aligned with the environment in which it is deployed.

Just in Time Fueling

The second aspect of the ASPIRE methodology is to apply just in time fueling procedures to commercial passenger flight operations. Although ASPIRE is a proponent of Just in Time (JIT) fueling, other agencies have similar initiatives to reduce costs based on this methodology. The US Air Force (USAF) applies lean fueling procedures to certain fleets of aircraft to decrease operating costs.

Many aircraft are fueled in advance of their intended use to ensure that fueling operations do not interfere with other ground operations closer to departure time. This approach requires the utilization of standardized fuel loads that may not be appropriate for aircraft utilization. In the case of the USAF, many KC-135 aircraft were previously being fueled with 80,000 pounds of fuel regardless of the flight requirement.

The fuel required to carry the unused fuel throughout flights at Altus Air Force Base, Oklahoma was found to cost between \$1M and \$1.5M annually (Heseltine, 2007). Aircraft weight directly impacts the amount of fuel required to operate the flight, and data availability close to departure time permits precise control of these factors. Although the USAF model requires less planning, commercial operations benefit from positional awareness and data availability directly to the flight engineer during pre-departure operations.

Two variable factors can have notable impact on commercial aircraft weight and cannot be precisely calculated until the flight is closed. These two factors are the weight of the cargo and the passenger count, both of which are widely variable until 20 minutes prior to departure (ASPIRE, n.d.). The possibility of supporting this data delivery utilizing the framework developed by this thesis within the 20 minute window supports this overall goal.

Positional accuracy on the airfield is a factor in this operation since the fueling process must be compacted into already other time sensitive operations. Without accurately controlling departure times by limiting or eliminating time uncertainty, the optimal fueling solution is difficult to achieve on a wide scale. The target framework will be capable of supporting the services required for this business solution.

A favorable condition that results from streamlining operations based on the current CONOPS in conjunction with more effective process modeling is noise abatement around airport areas. Noise pollution is typically a topic of concern of residents around an airport and its increase is unavoidable as traffic density increases. Practices such as APU reduction and streamlined departure procedures have the propensity to maintain similar noise levels throughout increases.

Additionally, the possibility of greater fuel efficiency has staggering implications on the aviation industry. Experts project that a fuel price increase as small as one cent per gallon increases industry operating costs by \$160M annually (Heseltine, 2007). The vast economies of scale involved in the commercial aviation industry present significant opportunities where even seemingly trifling efficiency improvements can produce astounding results.

Finally, the prospect to increase airport capacity without capital expenditures to construct larger facilities is an attractive possibility (Lockheed, 2008). The capacities of many airports are

constrained by factors that are not easily overcome. The most direct way to expand airport capacity is to build more facilities on the airport property to safely handle more traffic. Physical airport expansions are usually unpopular due to property encroachment or noise pollution. Initiatives to manage traffic without increasing the geographic space or noise levels around the airport are important topics in stakeholder management with local communities.

Requirements for Unified Architecture

The lack of a viable governance plan for the NAS has produced an environment with stovepipe technology architectures that are impossible to integrate. The evolving aerospace environment necessitates the development and deployment of new services that were unimagined during the expansion of the original solutions. The lacking integration of the underlying technologies prevents the continuous availability of transport infrastructure to support the services envisioned for the target architecture.

Future transportation infrastructure solutions must support the seamless collaboration of information workers through the availability of a common operating picture. This operating picture must be available to users that are currently working in segmented environments, necessitating the need for an enterprise level solution. An effective governance plan for the development and integration of future solutions is required to ensure longevity and the assurance of meeting user needs.

Services from three different categories must coexist to ensure the optimal operation of the NextGEN architecture. These are Air Traffic Services (ATS), Airline Operational Communications (AOC), and Air Passenger Communications (APC) (Ayaz et al., 2009). Air Traffic Services are currently under heavy development and have diverse stakeholder groups that include government agencies and the aerospace industry as a whole. Airline Operational

Communications are driven by the airlines with the overall intent of ensuring efficient operations through their own internal communication and cooperation with Air Traffic Services.

Air Passenger Communications are the expectations that passengers have when utilizing flight services such as in flight Internet access. Unlike ATS and AOC services, APC services have not been well captured during the requirements definition process. The airline industry is currently struggling with topics such as how to serve customer desires under the current architecture and should ensure that sufficient headroom to serve this developing trend. Failing to do so may impose reengineering requirements that are costly or technically prohibitive and lead to poor customer satisfaction.

However, these requirements could significantly impact the deployment of services should stakeholders have unrealistic expectations of the technology's capabilities. The inclusion of these services into the same fabric as surface communication systems that provide life safety could have detrimental effects on delivering the required quality of service. This thesis will recommend controls to segregate such requirements from the proposed framework and an alternative infrastructure.

Complications

Equipment Age

The most prominent shortcoming of the current technology is the age of the NAS infrastructure. Most of the bedrock technologies that are utilized for everyday functionality for airspace management were deployed well before the development of modern communication standards. Unlike many technology streams, newer standards were not required to be backwards compatible with these legacy technologies due to the inherent restrictions of adopting some properties.

This restriction has presented architects with an environment where legacy technologies are commonly applied for solutions that receive newer technologies in other industries. The current operational environment presents significant opportunities to achieve operational efficiency yet careful migration planning is required. Due to the mobile nature of users in the NAS, migrating user populations in segments is nearly impossible.

Conversely, the FAA has been forced to develop and deploy services and solutions without receiving the full benefit. For instance, services to enhance navigational performance have been deployed but even partial functionality is only available if the aircraft is properly equipped to process the data. From a transformational standpoint, the largest problem modernization efforts face in supporting converged solutions at the airport surface is the divergence of service evolutionary paths.

Labor Relations

Technology adoption is further complicated by ongoing labor issues in the industry that will be difficult to address through technology alone. One of the primary difficulties in the aerospace industry is the availability of air traffic controllers, the management of which is tightly controlled by the FAA. Shortages in air traffic controllers make the work environment what many believe to be one of the most stressful workplaces in the US.

Although more modern systems could alleviate some of the controller workload while making many tasks more intuitive, slow adoption frustrates progress. The time that would be required for retraining is also complicated by the termination of approximately 11,000 air traffic controllers who went on strike in 1981. To ensure that conditions would not return to prestrike conditions, the terminated employees were subjected to a lifetime employment ban from the FAA (Bucher, 2000).

A replacement workforce was trained while military and a small contingent of civilian controllers remained on the job. Since nearly 70% are nearing retirement age, architectural transformation efforts will be complicated by another employee turnover. In contrast, this does present an opportunity to train new controllers while deploying new equipment but would require methodical management of project timelines that could prove costly.

Meanwhile, the NextGEN CONOPS is focused on reducing aircraft separation which will result in higher density airspace. This will require that new solutions meet much higher performance measures than the technology that they are replacing (Sherry et al., 2009). When considering the margin of safety required for aerospace operations, the tolerance for unavailability is nearly nonexistent. Furthermore, the framework produced must offer significantly higher instances of opportunity to utilize position information and collaboratively communicate.

Future Transmission Mediums

Early conclusions from the Future Communications Studies established the precedence that the future radio system would be required to support an IP networking environment (Gilbert & Budinger, 2007). This limited the pool of potential applicants to those that currently support IP functionality. Furthermore, this decision signaled the consensus that supporting the availability of network applications throughout the architecture would be a fundamental requirement.

802.11

WLAN technology was an early contender for NextGEN solutions, especially for those service areas where infrastructure construction was possible. Though not adopted as part of the FCS phase three research results, 802.11 technology offers opportunities for service delivery at

the architecture edge that could not otherwise be delivered. Such fringe areas include certain areas of the airfield that are the responsibility of the aircraft operator.

For this reason, the largest stakeholder group that has an interest in service delivery at the architecture boundary are aircraft operators. However, management of this responsibility is not clear since addressing operational shortfalls could benefit both parties. Additionally, a wireless solution utilizing 802.11 technologies would require Part 121 certification from the FAA, necessitating the interest and action of both parties (Mitchell, 2006). Possible services that could be delivered through the 802.11 segment in conjunction with the business process owner are shown in Table 3.

Process Owner	Service
Service Provider / Aircraft Operator	VoIP
	Flight Data
	Dispatch Information
Aircraft Operator	Weight and Balance
	Fuel Data Transfer
	Navigation Database Uploads
	Chart Updates
	Electronic Logs
	Maintenance Data
	Airframe Specific Uploads
	Preflight Data Uploads
	Engine Trending
	Video Server Uploads
	Point of Sale

Table 3. Possible services delivered via the 802.11 segment.

802.16e

After the completion of several iterations of Future Communication Studies, the FAA and Eurocontrol made the joint recommendation to the aviation community that the 802.16e standard be the dedicated transport technology deployed at the airport surface. This recommendation included a formal request to the IEEE 802 working group that they develop a specialized

aeronautical C-band in the unused 5091 to 5150 MHz range (European Organization for the Safety of Air Navigation, 2009).

Although equipment based on the standard is not currently manufactured, simulations based on MATLAB Simulink exceeded performance requirements under all conditions (Gilbert & Budinger, 2007). Due to requirements to test tangible equipment after it is produced, it is likely that Part 121 certification will be required at a later point. However, the bandwidth performance is unlikely to differ from the standard 802.16e performance profile.

RTCA paper 182-09 described further goals for airport wireless communications research to define certain aspects of expected 802.16e performance. Primarily, the board aspired to define the characteristics of the transmission medium when utilized for aerospace specific applications. Specific characteristics include power class profiles, resource allocations, and channelization standards based on airport class and size (Williams, Hall, Alope, Phillips, & Henriksen, 2009).

While these specifications meet performance requirements cannot be understated, creation of a framework such as those produced through this thesis will reinforce efficient bandwidth engineering. To ensure that these two goals are congruent, the RTCA proposed Minimum Operational Performance Standards (MOPS) to guarantee the conformance of protocol, radio, and interference to meet fitness of purpose (Williams et al., 2009).

The NASA Communications, Navigation, and Surveillance (CNS) test bed at Cleveland airport was established as an operational proof of concept lab. The responsible agencies worked towards analyzing and endorsing components for the future technology domain utilizing Action Plan 17 recommendations, with the channelization methodology yet to be developed (Hall & Budinger, 2007). A deliverable of this thesis will be to predict bandwidth utilization for the service framework that can be applied to channelization schemes.

802.21

Regardless of the evolutionary path applied to the technology architecture, one of the most challenging undertakings will be unifying the communications fabric to support service delivery. NAS users move through the delivery area in an unpredictable manner necessitating the requirement to migrate from one transport fabric to another while maintaining communications sessions. Meanwhile, aviation safety standards require an incredible level of performance that must be supported by robust availability. The possibility of controlling quality of service through selection of delivery modes presents the most flexible option for robust service delivery in this fluid environment.

FCS is focused on investigating the possibility of utilizing IP capable mediums to deliver the services desired under the NextGEN architecture. These independent studies should consider the capability to handover services between the target technologies as a selection criterion (Gilbert & Budinger, 2007). Failing to address the prospect of tightly integrating the technologies chosen for the future architecture will present a solution that suffers from segmentation limitations similar to the current scenario.

The need to transition between the transport technologies within the NextGEN architecture will be the key enabler to overcoming the limitations imposed by legacy solutions currently in use. Considering the diversity of the current technology domain, maintaining communication sessions is not a possibility since a common technology is not available. Mobility requirements will be driven by speed and location that must be supported by the technology. The limitations of the technologies under consideration for the target architecture in terms of velocity and approximate bandwidth per cell are found in Figure 3 (Zhang & Hsiao-Hwa, 2008).

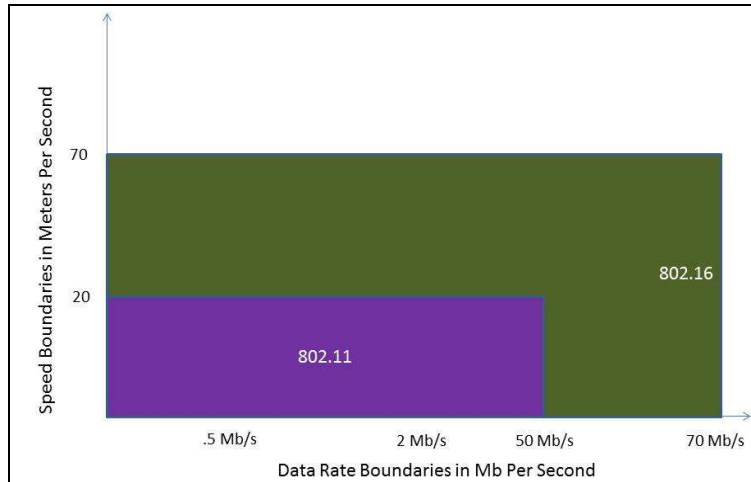

Figure 3. 802.21 Transitional Boundaries Based on Velocity and Data Rate

The 802.21 Media Independent Handover (MIH) group developed an interface to be integrated into future 802 standards to meet such transitional needs. This interface is to be employed to maintain mobile sessions regardless of the underlying technology. Factors such as link state changes, desired quality of service or other parameters could be employed to trigger such actions (Koodli & Perkins, 2007). This functionality will be paramount in controlling many factors in the framework proposed by this study and will be recommended as a possible control mechanism at certain transition points.

Current Architecture

Framework Components

The key element in developing new technology segment level initiatives to deliver the improved positioning solution for NextGEN requires understanding the current architectural components that interact directly with the aircraft. From a broad perspective, these two technologies fall into the CNS domain categories of communication and navigation. While not mutually exclusive, these two services are currently delivered to the aircraft through different service streams.

Communications

The primary means of information delivery to end users is through the employment of UHF and VHF radio systems. The direct communication supported by this technology is difficult to replicate utilizing different technology due to the highly mobile nature of users (Gilbert & Budinger, 2007). Unavailability of a direct migratory path presents limited options for a clear lifecycle replacement and exponentially complications migration. Matters are significantly complicated by the requirement for significant changes to support long term viability of the chosen technology.

Most voice services are carried by 25 kHz VHF carriers that are channelized and separated by 8.23 kHz in Europe and 25 kHz in the United States. Experts in the United States have considered adopting 8.23 kHz channel spacing as a mitigation strategy, but the benefits will not significantly lengthen the solution's lifespan. The situation is further complicated by the time that would be required for a retrofit rather than a direct migration.

In the United States, Department of Defense aircraft represent a large user segment and retrofitting this stakeholder group could be incredibly costly. Transitioning civil aviation components while neglecting the requirement to support interoperability for military systems will not produce a static environment capable of delivering a stable service. These needs and constraints continue to compress the time horizon in which a migratory solution must be available and applied.

On a smaller scale, Public Safety Radio (P34) is utilized for voice communications and presents difficulty for migrating to a VoIP solution. The requirement for first responders to utilize this band makes it impractical to converge the entire fabric to an IP network which will ensure its utilization well into NextGEN deployment. The possibility of creating an attachment

point for P34 networks to the converged IP network will be a design requirement to support e-enabled aircraft.

Very High Frequency Digital Link (VDL) was deployed to simultaneously extend the life of 25 kHz voice systems and reduce the workload on air traffic managers by sending automated messages to users. FCS studies realized that VDL services would eventually feel the same operational strain as 25 kHz voice while not sufficiently offloading enough traffic to extend the life of the underlying voice component. Like the voice solution that it supports, researchers felt that a single technology would be able to offer a direct migratory path (Gilbert & Budinger, 2007). During application of IP conversion approaches, the utilization of similar transitional iterations of technology solutions may be required.

While the replacement service for VDL will have a low bandwidth requirement, the current solution does not have sufficient bandwidth to support robust encryption (Ivancic, 2006). Like many present NAS communication systems, the common approach to network defense is security through obscurity. Transition to commonly available technologies will require additional considerations to prevent intrusion and will be considered as a service component of the framework produced by this thesis.

Navigational Aids

The navigational domain is similar to communications services in that a user is likely to continually receive services from more than one source. However, the source or quality of signal received will have a profound impact on the accuracy of the user's positional calculation. In this case, the quality of the services received must be matched with the operation being performed by the user at a specific point in time. To facilitate this operation, the FAA has developed a measurement known as Required Navigational Performance (RNP).

The measurement of RNP falls into three bands, those that can be achieved with only a Global Positioning System (GPS) signal, those that require Satellite Based Augmentation Systems (SBAS), and those that require Ground Based Augmentation Systems (GBAS). NextGEN architectural components that operate as the primary SBAS and GBAS components are already available as the Wide Area Augmentation System (WAAS) and the Local Area Augmentation System (LAAS). The relationship of these components within the architectural domain can be found in Figure 4 (Eldredge, 2009).

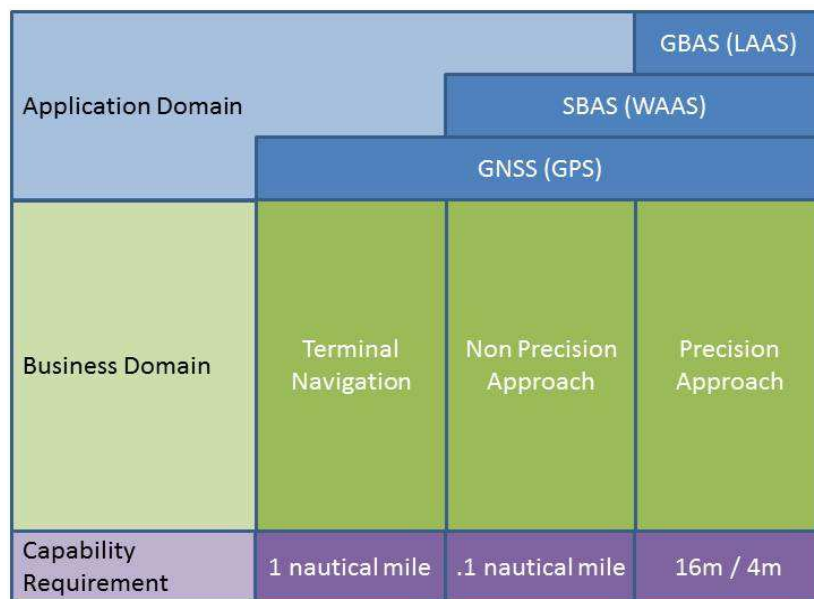

Figure 4. Navigational Architectural Domains.

While the GPS service is available throughout the architecture as a satellite based service, services to enhance the accuracy of position calculations must be delivered separately. For the utilization of LAAS at or near the airport surface, a local signal must be delivered to achieve the desired capability. Considering the distinct variation in this correction algorithm between locations, the FAA has proposed that it be delivered through the ATS data stream. Considering the capability of VHF ATS is currently limited, IP conversion offers greater capacity to deliver this capability. While the data requirements for such an algorithm are not available, this is an

example of a future service that should be anticipated and all available bandwidth should not be committed to the framework developed by this thesis.

Although this positioning signal can be enhanced, additional provisions need to be foreseen to continuously share these results with others. Disruptions to communication or loss of situational awareness can still attribute to the user becoming unaware of their position relative to other users. Future initiatives require that user positions are communicated without the requirement for human interaction. Such a requisite necessitates that this framework delivers the capacity to support this capability.

Phases of Flight

Stable service delivery in the NextGEN architecture is subject to the turbulence attributable to incredible user mobility. The lack of a single technology capable of delivering a service throughout the user environment presents scenarios encountered in few other computing environments (Dyer & Platt, 2006). The states that an aircraft travel through during a single flight operation are referred to as the phases of flight and are illustrated in Figure 5.

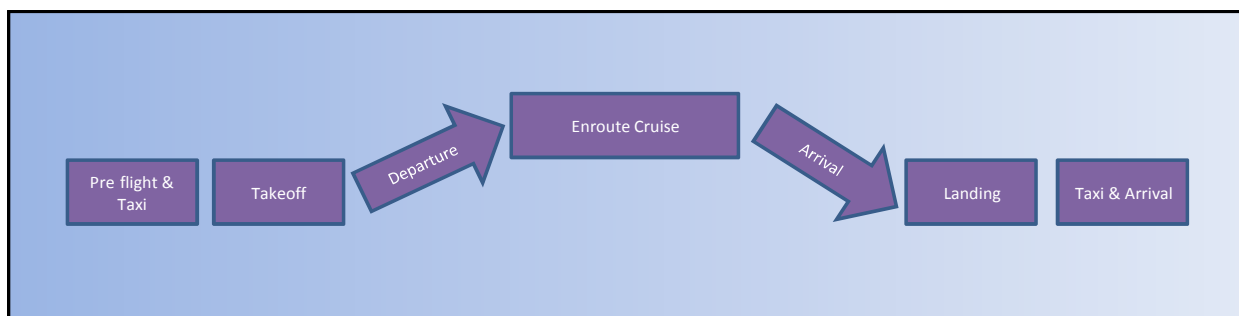

Figure 5. The Phases of Flight.

Understanding the phases of flight is a requirement to address the service delivery conditions that fluctuate during user sessions. Stable service delivery requires alignment of the technology and business architectures to ensure delivery throughout within the bounds of the

delivery area. Considering the high level of life safety required during flight operations, inconsistent service delivery will be an unacceptable condition.

Limitation of the solution space within phase of flight boundaries presents the research environment with a stable platform for solution development. Finally, the inability of the transport solutions presented by the FCS to serve every phase of flight roughly correlates to these boundaries. An additional deliverable of the thesis will be to demark these service boundaries and align them with the proposed framework.

Chapter 3 – Methodology

User Traffic Study

Perhaps the most vital step in designing an effective service or framework of services is predicting the number of users that will utilize a service. Aspects of service delivery will vary significantly based on the number of users that simultaneously request access. Topics such as contention and quality of service are important topics in networks requiring high rates of availability such as converged air traffic control networks.

The initial step of this study will be to define the target service area where the framework will be deployed. Rather than being defined by only a location, the service employed will also be limited by the state of the user in terms of velocity and altitude. To define this foundation for the case study, the phase of flight and servicing technology must be synchronized.

While the body of knowledge has recommended 802.16 technologies, the bounds of the delivery area and portfolio of services to be delivered are yet to be discussed. The purpose of this step of the study is to recommend a point of demarcation for the service based on phase of flight. Furthermore, the utilization of 802.11 technologies were initially mentioned but later neglected by the body of knowledge.

The outcome of this case study could be utilized to discuss the deployment of WLAN technology to offload users from the WiMAX segments to reinforce stable service delivery. If the user is not forced to depart the 802.16 segment, the number of users could vary based on conditions outside of the provider's control. The source of information and the control source for moving users through the segments recommended by this study are arrival and departure time tables.

Publically available time tables will be utilized to conduct an independent study to estimate the number of users that could simultaneously utilize the recommended service framework. These time tables will be utilized to calculate a variable defined in the body of knowledge as a Peak Instantaneous Aircraft Count, or PIAC. Unlike other studies, this PIAC calculation will be focused on the target service delivery area under study during this thesis. The PIAC will be applied in later steps of the thesis to assist in determining the feasibility of deploying the service framework utilizing the 802.16 technology as proposed by the supporting agencies.

Current Service Framework Definition

Considering that the delivery area has been limited during the initial step of this study, the services to be delivered within these limits must also be defined. The primary methodology for migrating from legacy technologies to IP based equivalents will be to select those that most appropriately mimic the functionality of the current services. Furthermore, this study must ensure the services selected must be deliverable within the limitations of 802.16 performance thresholds.

After the service area and traffic levels have been calculated, clearly defining the services that could be replaced by IP based technologies is vital. Services that have the potential to be replaced will be defined to ensure that the selected replacement is fit for the same purpose. Publically available information regarding utilization will be utilized to develop a realistic service framework.

Future Service Framework Development

Replacement services will be selected that support the business operations and offer a sensible transition from the legacy services. These services will be based on commercially

proven services that are utilized for similar purposes. This approach supports the deployment of off the shelf services that do not require development while providing an accurate estimate of the underlying infrastructure requirements to support these services.

Bandwidth estimates for the 802.16 user segments will be produced utilizing this service framework and the associated framework. These bandwidth estimates will be further refined to predict the WiMAX operating mode required to support these segments. Moreover, the code rate and frequency utilization can be predicted based on this utilization.

Secondly, bandwidth estimates will be compiled for the 802.16 backhaul segments to support the overall network. Similarly, the operating mode, code rate, and frequency requirements will be predicted based on the overall service requirement. The compiled requirements of the user and backhaul segments will be used to calculate approximately how much of the available frequency spectrum will be required to support the service framework.

Chapter 4 – Project Analysis and Results

User Traffic Study

The common factor between NextGEN bandwidth estimation and RF system engineering approaches are the number of users that the network will support. The number of users moving through a NextGEN operational area is defined as the PIAC. Since the transmission medium is link agnostic for this modeling approach, this value will be defined utilizing the same terminology.

For the purposes of transparency, it is important that the method of calculating the PIAC applied to the framework and bandwidth applications is published. Through referencing other International Civil Aviation Organization (ICAO) research papers for spectrum requirement development, an approach to PIAC calculation was found. The researchers utilized world time tables for aircraft flights and correlated the estimated communication traffic values (Inoguchi & Suzuki, 2008).

Considering the focus of this paper is on delivery of solutions on the airport surface, timetables will be utilized that can be applied to calculate how many users would simultaneously be in the target segment. Timetables are available for the case study location and are categorized by departures and arrivals. As discussed in the literary review, flights will move through several phases of flight within the target service delivery segment and these categories correlate to phases of flight. The points of information availability correlated to the phases of flight are displayed in Figure 6.

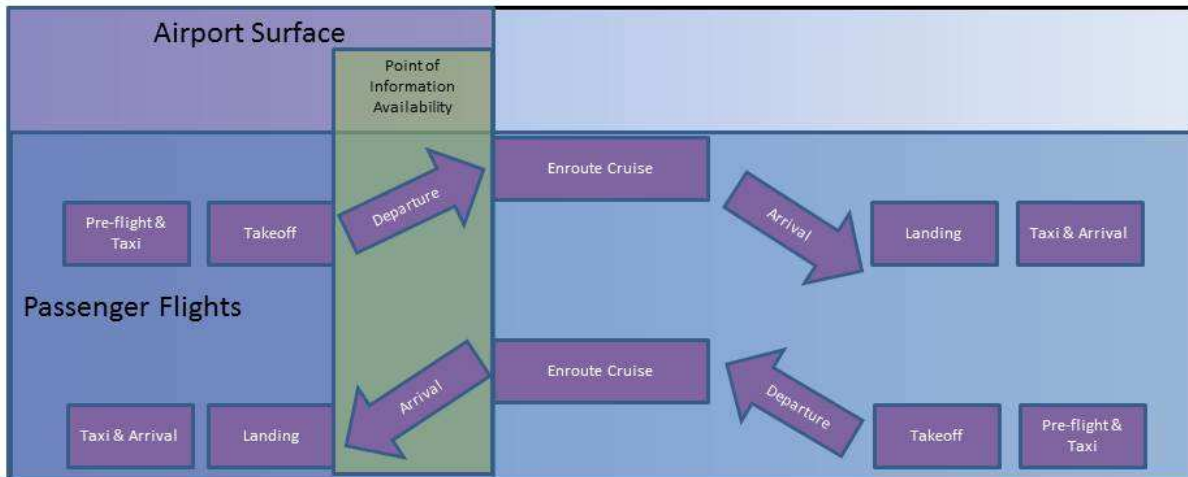

Figure 6. Correlation of Information Availability and Phases of Flight.

Definition of the service delivery modality is limited by several factors. Within the 802.11 segment, users are limited by velocity and the distance from the service delivery area that falls under the aircraft operator's responsibility. Within the 802.16e segment, users will be limited by their upper velocity and must be transitioned to another transmission medium to maintain the desired QoS at the appropriate point in time.

Subsequently, it is impossible for an arriving or departing user to avoid moving through the phases of flight in the required sequence. Therefore, the target data will present an acceptable estimation of the aircraft that are in the desired research space. However, some functionality within the PIAC model will be required to estimate the number of users that will be simultaneously located within the target service area.

Definition of the target service area is based off the requirement where users will be best served by the 802.16e transmission segment. As proposed in the literary review, service delivery with this technology is attainable at a user velocity of less than 70 meters per second, which marks the delivery boundary within the arrival and departure phases. Secondly, the employment of an 802.11 infrastructure at the aircraft taxi boundary presents an opportunity to offload users onto an adjacent transmission infrastructure and segment service delivery not directly associated

with the target solution. The infrastructure service boundaries and 802.21 control points are illustrated in Figure 7.

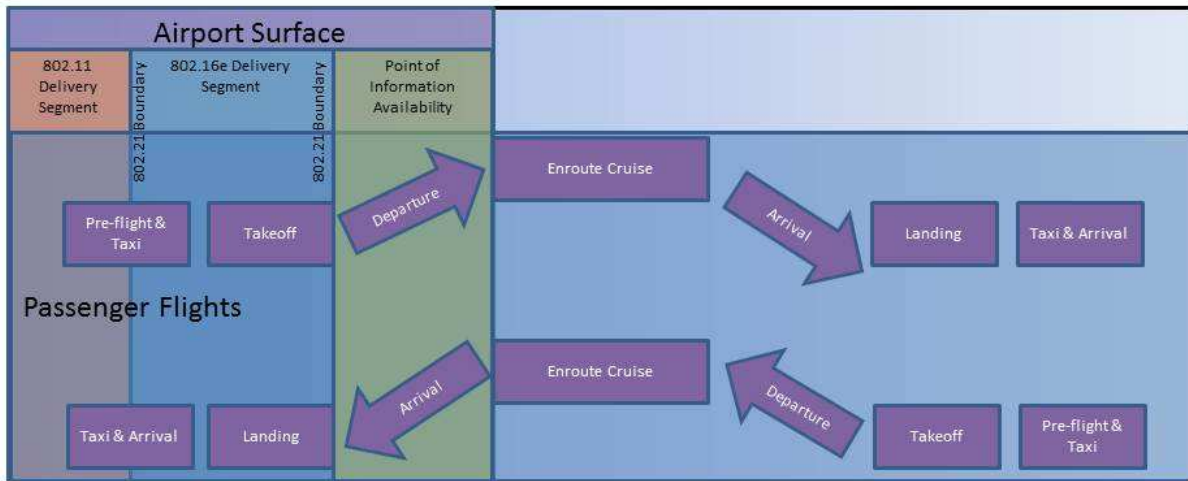

Figure 7. Wireless Delivery Segments and Control Boundaries.

The traffic study must estimate the amount of time that a user will require to transverse the 802.16e service area between the point of information availability and being served by the 802.11 delivery segment. For this purpose, the traffic study will consider a user in the 802.16e segment for 15 minutes after the posted departure time and 15 minutes before the posted arrival time. These times will be correlated to create a PIAC at 60 minute intervals throughout the day to calculate the highest possible user load that could be expected.

The flight code from each flight on the timetable was entered into a spreadsheet during the time periods that the user would be active between the proposed 802.21 boundaries. The totals for each time period were utilized to represent the maximum number of users that could be expected under current utilization. The study found that the highest PIAC occurred on the second day of the week at 0800 hours with a traffic count of 147. A graph representing the hourly calculations is depicted in Figure 8 and these calculations will be applied during the remainder of this study.

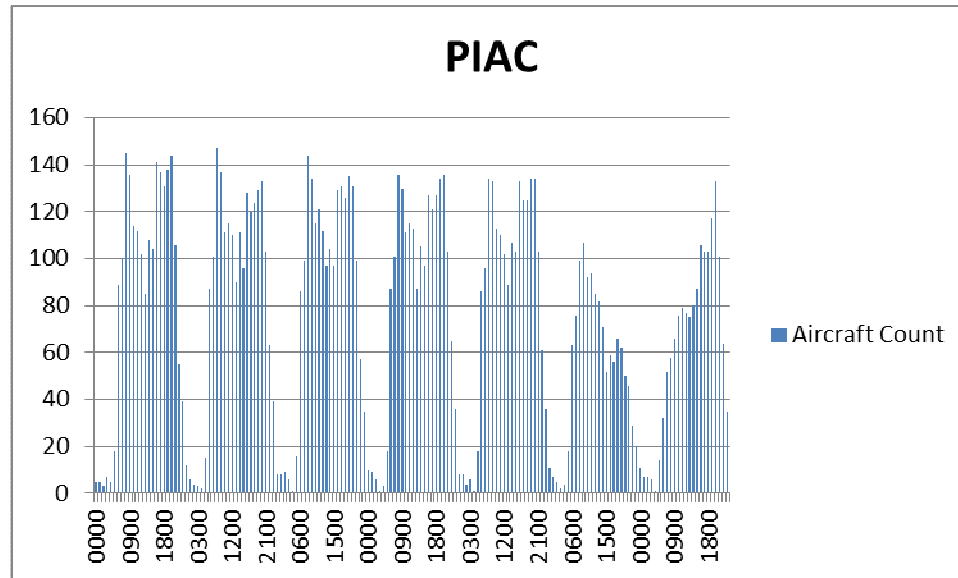

Figure 8. Hourly Peak Instantaneous Aircraft Count.

Definition of the Current Service Framework

Voice

VHF

The primary means of controlling aircraft is primarily facilitated by VHF legacy voice communications. The frequency range reserved for aeronautical communications is 118 to 137 MHz with two approved channelization methods. In the United States, channels are separated by 25 kHz which provides 76 channels at full efficiency. In other regions of the world, an 8.33 kHz channelization method provides for a maximum of 228 channels.

At many locations, high operational density necessitates careful frequency management to prevent the overlapping utilization of frequencies. Such an approach precludes many airports from utilizing the entire spectral efficiency of the frequency range. A central authority is required to issue and manage the utilization for these voice communication carriers. The 43 primary channel assignments and their intended utilization for the case study are found in Table 4.

118.050	Ground Control North	126.750	Approach / West	131.450	Safety
118.250	Approach / Arrival	126.900	Flight Information Center	131.500	Airline Use
118.600	Tower	127.225	West Control Sector	131.425	Maintenance
120.100	Approach / Final	127.575	Final Departure	131.625	Airline Use
120.775	Tower	127.800	Enroute Air Traffic	131.900	Airline Use
121.500	Distress	128.800	Approach / East	131.950	Mixed Use
121.600	Air Cargo	128.200	Approach / East	132.475	General Aviation
121.875	Ground Control South	128.450	Approach / East	133.125	Cargo
121.950	Air Cargo	128.800	Approach / North	131.625	Airline Use
122.100	Information	129.325	Military Flight Information	131.675	General Aviation
122.500	Information	129.650	Ground Control	131.775	Airline Use
123.100	Rescue	129.725	Final Departure	131.950	Business Aviation
123.300	Ground Control	130.200	Reserved	132.475	General Aviation
125.000	Approach / South	130.550	General Aviation		
126.625	Departure	131.100	Approach / West		

Table 4. Primary VHF Channel Assignments.

Advanced VHF functionality facilitates the broadcasting and receiving of multiple frequencies through a single omnidirectional antenna. This functionality is achieved through coupling multiple transmitters or receivers through the employment of specially manufactured transmission equipment (Stacey, 2008). This functionality permits transmission sites around the airfield to be custom tailored to provide the desired services at targeted locations. An example of the communications infrastructure is illustrated in Figure 9.

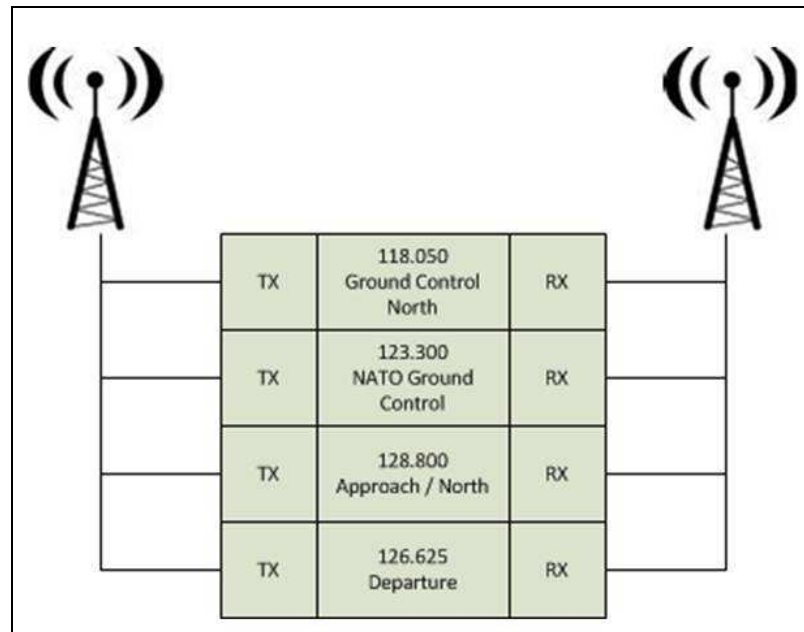

Figure 9. Example of the VHF Voice Communications Infrastructure.

While Figure 9 shows four channels in use, channel limitations are not bound to this numerical constraint. Instead, as long as the frequencies are in the same band and appropriately spaced, this deployment model is viable for adaptation to a wide range of scenarios. Considering the case study, the number of channels deployable in this configuration is not a limitation for consideration. The purpose of this project is to deliver an IP capable model that is able to deliver all available voice carriers throughout the domain while removing the constraints of spectral efficiency.

Public Safety

P34 radio is governed by the TIA-902 family of standards and is officially titled Public Safety Radio. While VHF addresses the requirements for air to ground communication, many first responders involved with airfield operations utilize P34 radio. Due to the differences between operation under normal conditions and those required during emergency situations, retention of the P34 as a legacy technology radio network is a necessity.

Communication needs of mobile users such as fire fighters, police officers, and emergency medical personnel will not be best served through IP conversion. However, the requirement to communicate between mobile segments within the P34 network and the air traffic management environment will require consideration. FCS researchers have proposed that a connection point between IP network and P34 radio network will be required. The proposed bandwidth requirements for these services are found in Table 5 (Dyer & Budinger, 2006).

TIA Standard 902 Common Title	Bandwidth Requirement
Narrow Band	10kbps
Wideband	100kbps
Broadband	1000kbps

Table 5. Proposed TIA-902/P34 Public Radio Bandwidth Requirements.

Data

Data requirements are currently supported by the same infrastructure as voice with several distinct differences. First, data service is only supported by a broadcast topology that provides limited text messages from air traffic managers on the ground to aircraft users. This restriction is imposed by the performance limitation of the VHF spectrum that is utilized to support this service.

Segments of the upper VHF band are reserved to serve as data channels on the 25kHz channelization scheme. However, additional guard band requirements prevent the utilization of every channel in the range. The upper range of VHF voice frequencies were reserved by the ICAO for data services in 1996, and the channels commonly reserved for VHF Data Link (VDL) services in are found in Table 6 (Stacey, 2008).

European VHF Data Channel Assignments	
Channel	Frequency in MHz
Channel 1	136.725
Channel 2	136.775
Channel 3	136.875
Channel 4	136.975

Table 6. Common VDL Channels.

By developing channel coverage templates in the United States and calculating traffic values, researchers were able to calculate the amount of bandwidth required for VDL cells (NASA, 2006). Unlike many other communication standards, protocol overhead was not found to have a logarithmic relationship to the data rate. Rather, the overhead shows a consistent ratio to the data payload throughout the performance range.

The resulting estimate showed the approximate bandwidth required per cell while showing a consistent relationship with the level of user traffic. Researchers found that variations were caused by retransmissions that were necessitated by collisions detected by the Carrier Sense Multiple Access (CSMA) mechanism. The output of this research presented an algorithm that is capable of predicting the bandwidth required in kHz at a specified PIAC.

Location Information

One of the most common approaches to locating aircraft on the airfield is for the ground controller to visually confirm an aircraft's position. The controller will correlate this information to direct the aircraft on the airfield. As an alternative, the ground controller may ask the flight crew to validate their position by confirming visual markers on the airfield via radio communications.

Both of these approaches pose difficulty since they rely heavily on communication between the controller and the aircrew. Errors in human perception and communication obstacles potentially interrupt the direct availability of this information to the target audience. The

deficiency in the availability of this solution is evidenced by requiring as low as 99.9% reliability in some locations (Stacey, 2008). The target architecture vision seeks to remedy reliability and deliver increased information to a wider audience that is not available with the current solution.

A tertiary approach to locating aircraft on the airfield is the employment of ground radar systems. While the functionality of such systems do provide the controller with aircraft position information, these positions and guidance must still be communicated utilizing the same means as visual confirmation. Additionally, nonrepudiation is not achievable utilizing this approach since only unencrypted communication methods are utilized.

Definition of the Future Service Framework

Voice

To support the desired availability, consistent service throughout the expected delivery area is required. To achieve this goal, the underlying technology must be capable of delivering voice capability throughout the architecture in an uninterrupted fashion. This capability must be congruent with the FCS recommendation to utilize IP capable transport technologies to support future requirements.

For the purpose of developing this case study, a service is desired that will support transitional and target architectures. The utilization of particular vendor services is not an endorsement, but intended to be an example of how architectural goals can be supported. Achieving the future architecture utilizing current off the shelf (COTS) technology will solidify enterprise architecture approaches while reinforcing OMB goals of fiscal responsibility.

Finally, the selection of particular services and protocols is meant to serve as a transparency measure for the research process. By defining the measures utilized to define the service framework, future researchers can critically review the methodology involved and make

appropriate recommendations for adaption to future conditions. While configuration management is vital in any framework, anticipating change is equally as important.

Considering the size of the NAS, it is unlikely that a complete deployment during which the entire domain will be migrated is possible. It is therefore likely that a technology that supports a transitional architecture by enabling the mixed use of VHF and IP communications sessions is required. Furthermore, channelization schemes will need to be retained throughout the transition period and into the target architecture to support the business domain.

The search for a solution that would provide a point of attachment for the RF network and facilitate IP communication sessions produced the Cisco Interoperability and Collaboration System (IPICS). The purpose of this solution is to enable communication in environments where mixed standards and platforms by utilizing IP infrastructure as a common boundary (Cisco Systems, 2003). A conceptual example of this deployment is displayed in Figure 10.

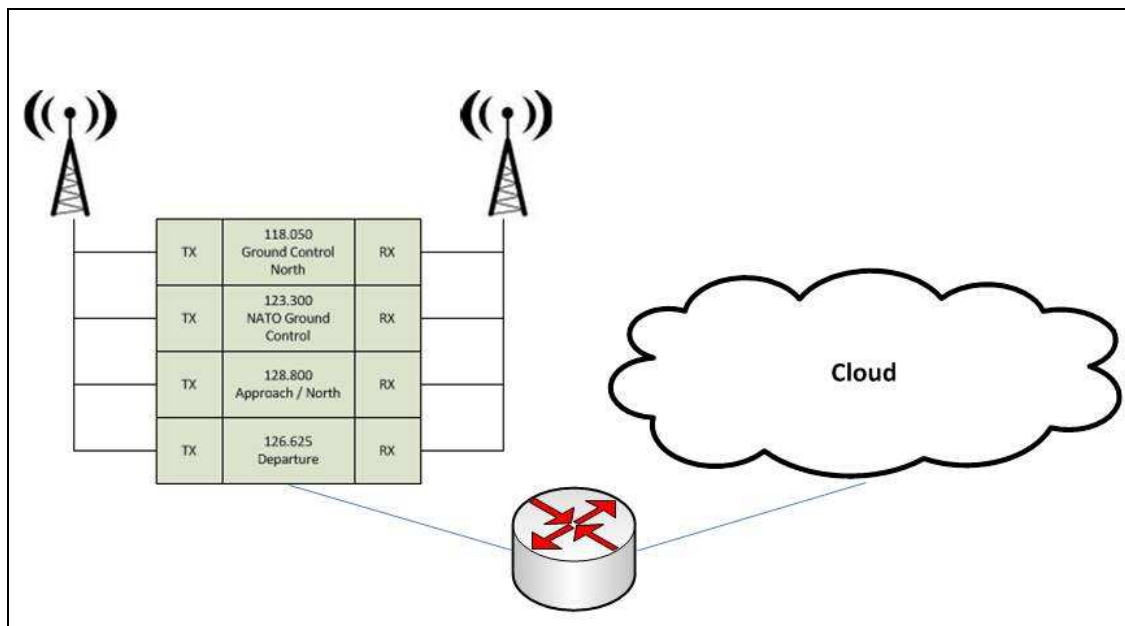

Figure 10. Logical Example of VHF and IP Boundary.

Bandwidth planning for this conversion requires two major decision points. The primary design criteria of most voice networks involve the selection of a compression method. Current technology solutions typically employ a codec and corresponding encoding method to convert an analog source to a digital data stream. In the case of the IPICS solution chosen for the case study, the two codecs available are ITU standards G.711 and G.729a (Cisco Systems, 2003).

The number of channels and business case support a high compression standard such as G.729a that is commonly referred to as an 8 KB CS-ACELP standard. While this high compression ratio is capable of conserving bandwidth, the additional processing involved introduces additional delay when compared to G.711. While this delay may not seem significant at first, a VHF conversation that transverses the IP cloud could incur an additional 100ms of delay even in optimal conditions.

Additionally, the less than optimal operating conditions under which radio traffic is transmitted will present wildly variable results at higher compression ratios. The employment of G.711 is closer in comparison to standard VoIP compression and produces more consistent voice results under varying conditions. For this reason, the case study will proceed with the utilization of G.711 as the desired codec utilized for voice compression.

The second major decision point that will impact network design and bandwidth utilization is the employment of the ability to mix voice streams. Although the segmentation of airfield operations into so many different channels could present challenges, the purpose is to divide this portion of the business domain into manageable segments. Mixing voice streams in the IP segment will not be executed to continue supporting this requirement.

However, stream mixing should not be confused with virtual talk groups (VTG) that permit users to operate on isolated channels. Stream mixing would not maintain the desired

domain segmentation while VTG utilization is a technology substitute for a user being able to select a desired voice channel to operate on. In effect, this functionality is a virtualization of VHF channel selection that would enable a user to have full access to any frequency with an IP connection point. An example of this functionality is shown in Figure 11.

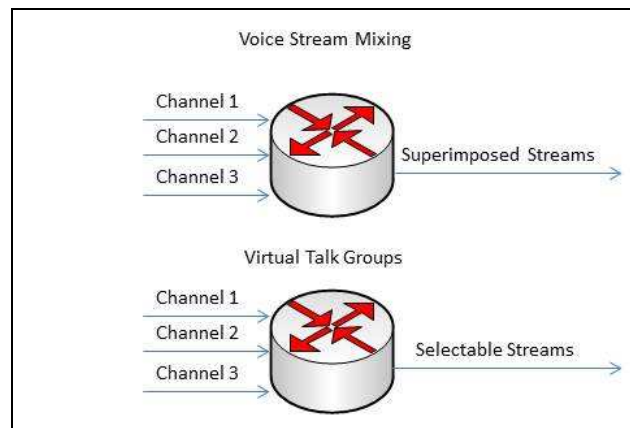

Figure 11. Example of Voice Stream Mixing and Virtual Talk Groups.

Location

Currently, location information is directly delivered to the end user on a transport technology external to the communications infrastructure. However, the ability to share positioning information is perhaps the most significant enhancement to situational awareness in aviation operations. Considering that one of the benefits of effective information technology projects is tailoring technology solutions to transform business processes, this scenario creates a tremendous opportunity for improvement.

The primary delivery method of position information is the Global Navigation Satellite System (GNSS) technology domain which is served in the United States by the Global Positioning System (GPS). Satellite signals are broadcast at 1575.42 MHz and position solutions are calculated by the receiver and displayed for the user (Crane, 2007). Two augmentation systems that have already been deployed under the NextGEN architecture modernization

program are the Wide Area Augmentation System (WAAS) and Local Area Augmentation System (LAAS).

GPS positing receivers calculate their position based on the time that the signals took to travel from the satellite to the user. When travelling to the Earth, these signals can become distorted due to irregularities in the atmosphere. The WAAS calculates a correctional signal through sampling positioning signals at several survey sights throughout the United States and broadcasting a comparative signal to two geosynchronous satellites. These satellites compare the corrected signal to the GPS signal received on Earth and broadcast a correction algorithm that specially equipped receivers apply for improved positioning (Crane, 2007).

The LAAS works in the same manner utilizing multiple GPS receivers at the airport surface. However, the primary difference between WAAS and LASS services are that corrections are broadcast utilizing VHF data link and the full deployment of LASS services will significantly increase VDL bandwidth requirements. Converting data link services to the IP domain will require that this capability is considered within the service delivery design.

Secondly, the deficiency between delivering positioning information to users and transmitting the known position of one user to another must be resolved. Although there are systems in place to identify aircraft on the airfield and correlate them with other identifying information, the 1090 extended squitter band (1090 ES) is extensively utilized to transmit information. Considering the expected saturation of 1090 ES, this capability should also be integrated into the IP service infrastructure.

In addition to the service required to enhance the accuracy of the GNSS signal, the user's calculated position must be broadcast to other users. While a one-to-many multicast originating from each user would require incredible network resources, the amount of resources required to

accomplish a single multicast would be more appropriate. The amount of data required to continuously update a single user position to a central service would be nominal while the existence of a single multicast to update all users would be the minimalist approach to deliver the desired service.

The conversion of other services within this case study has been modeled utilizing existing services. While the desired service will require some custom tailoring, the U.S. military's Blue Force Tracker system performs a comparable task under similar conditions. To deliver this service, a 3kbps uplink is required to update position information while a 120kbps multicast shares the centralized information (Osborn, 2008). For the purpose of this case study, this model will be utilized for calculations to produce bandwidth estimations.

Data

Perhaps the most revolutionary change in the NextGEN architecture will be the necessity to deliver data services to users. Although data services exist in the current architecture, they are primitive when compared to modern standards. Migration from low bandwidth broadcast data streams to an IP capable infrastructure presents special challenges in service design and network engineering.

Broadcast data utilizing the RF spectrum does not have to contend for the transmission medium in the same manner as IP environments where each user is directly addressed. Concepts such as multicasting will have to be applied to limit the resources required to propagate messages throughout the network. If such measures are not applied, the resources required to mimic the exact functionality of the current system would be incredible. Moreover, many researchers pursuing disparate technology domain applications are already considering the concept of data availability without focusing on the impact of the overall architecture.

The purpose of this case study is to consider the impact of converging VHF ATS data onto the IP network as a function of air traffic management. Within the confines of this study, additional requirements will not be added to the framework that are not directly related to the migration of the identified services or support the target solution. Specific research has been conducted to predict the bandwidth required to support this data requirement at other locations and will be utilized as a guideline for this study.

The bandwidth prediction calculations were executed utilizing a multistep process. First, the RF engineering factors that had the most significant impact on throughput were examined. To demark the initial study areas, the coverage areas for each zone were established and sites to cover any remaining dead zones were added. Next, traffic levels were calculated by establishing the Peak Instantaneous Aircraft Count (PIAC) for each coverage area (NASA, 2006).

The throughput required for each zone was based on the number of channels available due to frequency management concerns, the required channel rate, and the PIAC. The results produced an estimated channel rate ranging from 122 to 430 kbps (NASA, 2006). The results appear erratic since there are multiple factors in addition to several logarithmic functions; however, the range does produce an expectable result for conversion.

Although the bandwidth requirement for transitional architectures that require an IP point of attachment may require higher resources initially, the target architecture will result in a less resource intensive environment. Factors such as minimal frequency reuse in the VHF ATS domain will not be factors once the target architecture is attained. Furthermore, the required bandwidth for a solution utilizing VHF ATS architecture without an IP component is already at the maximum spectral efficiency for the band (NASA, 2006). Considering that this case study is

focused on meeting transitional requirements, utilizing the PIAC from this study will deliver a refined bandwidth estimate.

Refinement of the Future Service Framework

Application of the future service framework to a real world scenario requires fitting the service delivery framework to actual performance expectations. In the case of the solution in question, the load of users on the network will determine overall feasibility. Two factors that will have significant impact on the functionality of the service are the number of users and the bandwidth that each user requires.

Service delivery is further complicated by the quality of service required of the physical layer to support the desired applications. Not only must the solution surpass the minimum requirements to deliver the solution, performance must exceed user expectations. The deployment of many enterprise applications have failed because they were well engineered but the perception that the solution could perform better prohibited their successful adoption.

Delivery design must consider the expectation of all stakeholder groups to ensure that system adoption is not perceived as a failure that only spawns a replacement search. To support this concept, the total solution design should not exceed a significant capacity of the infrastructure to deliver it. Doing so constrains later migration paths and limits overall lifetime expectancy of the service framework. Additionally, assurance of additional operational capacity permits the application of other concepts that have not yet been researched to be applied to improve current solutions.

802.16e Service Framework

A vital component to establishing the service model for this segment of the framework is to establish a foundation that will be utilized for a common platform. This common foundation

will support the concept of architectural partitioning by providing clear demarcation points between technologies and services. Like other technology components, this template must be both scalable and reproducible throughout the architecture to be viable. For the purpose of this service framework, the services will be based on the utilization of 802.16e technology as illustrated in Figure 12.

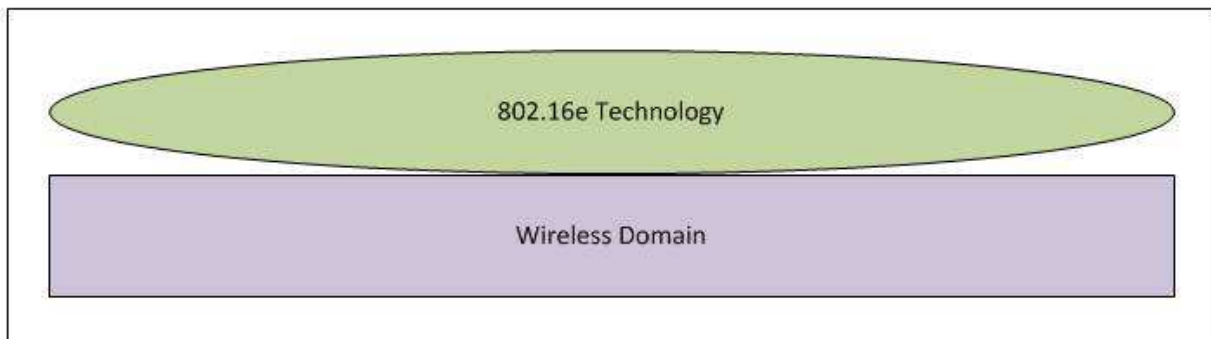

Figure 12. 802.16e Fundamental Framework Qualities.

The primary employment of WiMAX at the airport surface is intended to provide an evolutionary path for voice services. Although conversion to IP protocols from legacy FM carriers presents the opportunity to unify these currently separate channels in a unified contention space, they must still remain logically separated to support the current operational requirement. To support this explicit business constraint, the utilization of VTG was chosen for this thesis.

Although users may utilize only a limited number of voice channels within the VTG at a specified time, the infrastructure must be engineered to support this requirement. During transitional architectures, points of connection must be maintained between RF carriers and IP communication sessions. Facilitation of this relationship must be established by maintaining a distinct isolation between voice streams.

The application of the G.711 codec to the VHF 25 kHz voice segments produces a combined data stream of 0.36 MB/s. Although fixed location users will have the full bandwidth requirement, mobile users only have the requirement to utilize a limited number of VTGs. Though this requirement could be further developed through the more accurate definition of the business domain, the voice requirement of delivering one VTG within the architecture to a user segment is displayed in Figure 13.

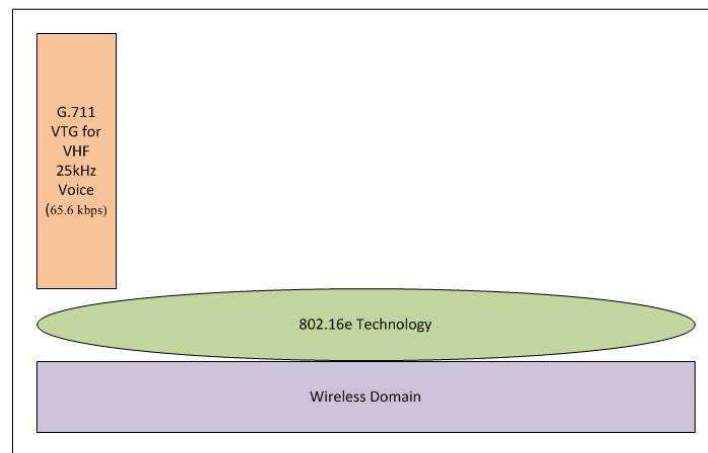

Figure 13. Calculation of the VHF VTG User Segment Bandwidth.

In addition to the voice requirement to support the 25 kHz voice requirement, a requirement also exists to accommodate P34 emergency radio. Although this carrier could technically be integrated into a VTG, this approach is not congruent with the business domain. Emergency radio communications must always be available independently of the 25 kHz voice requirements. While all 25 kHz users could be eventually transitioned to IP native services, some public radio users such as first responders are unlikely to migrate to an IP environment.

The independent evolutionary streams for voice services contribute to differing transitional requirements. While the near term architecture shown in Figure 13 is an evolutionary iteration, maintaining an attachment point between the IP environment and P34 radio will require

long term utilization of the G.711 codec. The architecture model that includes the 65.6 kbps data stream to meet this requirement is shown in Figure 14.

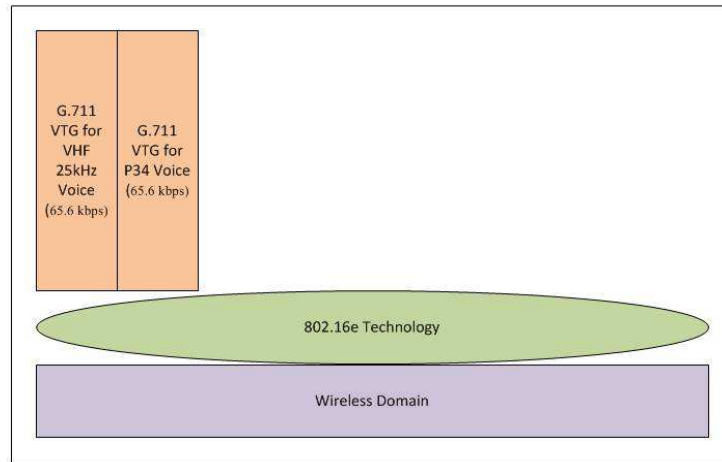

Figure 14. Calculation of the P34 VTG User Segment Bandwidth.

The transmission requirement to support improvement of positional awareness is the key component of the transitional architecture described by this thesis. The bandwidth required from this service was modeled from similar services that are available as COTS solutions. Utilization of the bandwidth required for these solutions during this modeling stage are utilized as a predictor for what services may require after tailoring to the target architecture. The bandwidth required for such solutions are asymmetrical in nature and described in Figure 15.

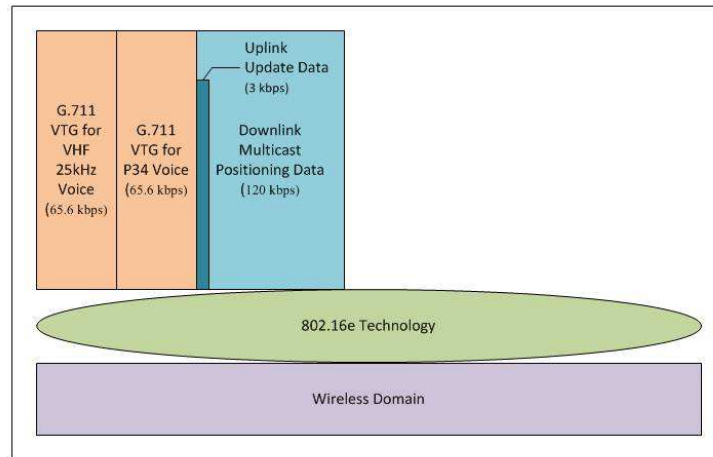

Figure 15. Calculation of the Positioning Solution User Segment Bandwidth.

Beyond the application of this case study, perhaps the largest impact on the IP network will be the conversion of data from legacy carriers. Although the IP environment offers advantages that ease the constriction caused by legacy carrier limitations, the transition is not without challenges. Researchers only have estimations of what the current load will be after transitioned to the IP infrastructure.

Although the highest possible channel rate of 430 kbps was anticipated, the rate can be refined based on the NASA study results now that the PIAC that was calculated by this study. The closest result from the study is a PIAC of 146 compared to this study's PIAC of 147 (NASA, 2006). The channel rate produced during this study was 171.6 kbps utilizing two frequencies. Since four frequencies are commonly available in the zone of the case study, the data rate was halved to 85.8kbps and applied to Figure 16.

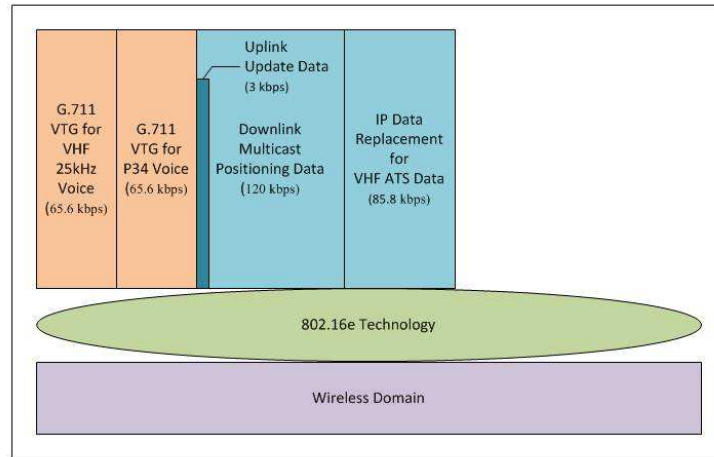

Figure 16. Calculation of the ATS Data User Segment Bandwidth.

Considering the massive size of the NextGEN architecture, developing security solutions will be a daunting undertaking. Notably, there is little available research addressing the subject of how the various agencies involved will address security concerns. While developing an architectural security approach is an important part of reaching the target architecture, a great deal of work remains in this area. While many solutions are left to be considered, security overhead is likely to increase overall requirements by as much as 20%. This bandwidth reservation calculates to 67.4 kbps and is displayed in Figure 17.

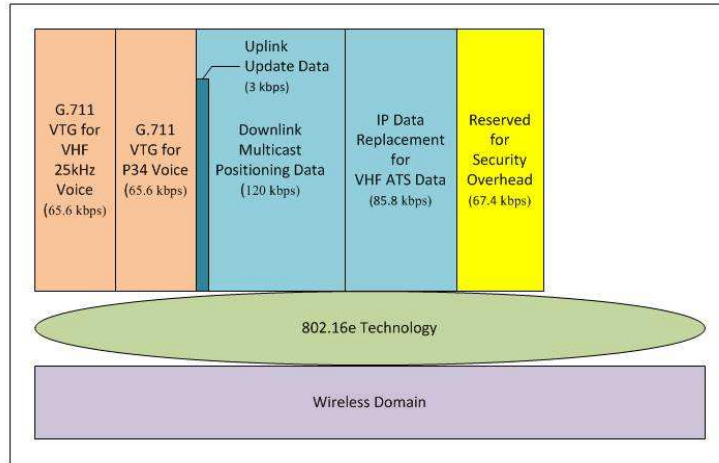

Figure 17. Calculation of Security Overhead for the User Segment.

User Segment Bandwidth Estimation

The service model developed to deliver the solution to the user segment predicts that the service will require 404.4 kbps. Current NASA recommendations to the IEEE have requested the reservation of up to 70 MHz in the C Band strictly for aeronautical WiMax utilization. These frequencies are typically subdivided into 10-MHz channels for service delivery. Furthermore, these channels can be divided into 5-MHz channels or fractionally divided to prevent overlap from omnidirectional arrays.

Assuming that one 10-MHz band could be utilized for user access with fractional reuse, the entire service area could be covered with one channel. Although this approach is effective for reserving frequencies, it does fractionally divide the available bandwidth. As an example, if one 10-MHz frequency is capable of carrying 12.67 Mbps in a point to multipoint configuration, one third of the bandwidth would be able to carry 4.23 Mbps. An example of this topic is illustrated in Figure 18 (Abate, 2009).

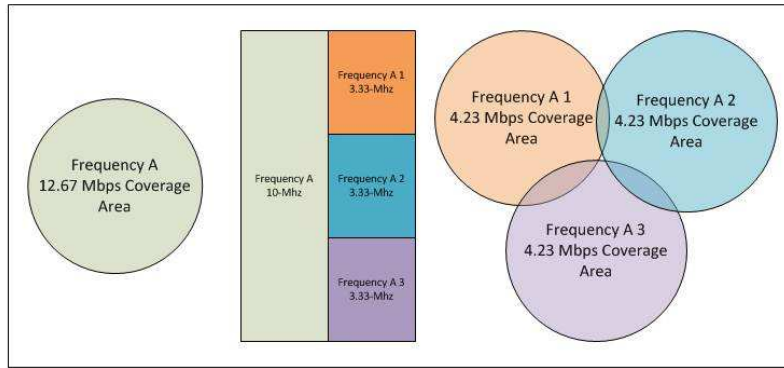

Figure 18. Example of 802.16e Fractional Frequency Reuse.

WiMAX equipment is capable of establishing a link based on the quality of the signal received by the equipment. The lower the signal-to-noise ratio (SNR), the greater number of bit states that can be decoded from the received signal. An increase in the bit states that can be simultaneously transmitted results in a higher overall data rate. Certain SNR thresholds permit the equipment to operate in modes that offer a significant number of simultaneous bit state transmissions. The operational modes and associated data rates when utilizing a 10-Mhz channel utilizing 33% fractional frequency reuse as depicted in Figure 18 is available in Table 7.

Mode	Code Rate	Download Fractional Rate 33%	Upload Fractional Rate 33%
QPSK	1/2 CTC 1X	2.11	1.57
QPSK	3/4 CTC	3.17	2.35
16QAM	1/2 CTC	4.22	3.14
16QAM	3/4 CTC	6.34	4.7
64QAM	1/2 CTC	6.34	4.7
64QAM	2/3 CTC	8.45	6.27
64QAM	3/4 CTC	9.5	7.06
64QAM	5/6 CTC	10.56	7.84

Table 7. 10-MHz Channel Data Rates Utilizing 33% Fractional Frequencies.

Equipment from different vendors exhibits varying sensitivity that supports widely wavering operational rates. Due to these differences, a predefined SNR cannot be established prior to equipment selection and network surveys. However, supporting the minimum 16QAM operating mode will ensure that the solution and current operating requirements utilize less than

10% of the network capacity. This leaves a significant threshold to increase to 64QAM to ensure high QOS and compensate for future services while utilizing approximately 3% of the available bandwidth at the highest operational rates.

802.16e Backhaul Framework

802.16e distribution points are interconnected utilizing the same technology deployed in a point to point rather than a point to multipoint configuration. These point to point configurations that operate on frequencies outside of the multipoint service links are commonly referred to as backhaul links. While the previously discussed model is accurate for the user segments, the backhaul segments will have different requirements.

A significant difference is the impact of the G.711 services utilized to replace the 25kHz legacy voice technology. Although VTG technology is utilized to limit the number of streams that are required by the user, the backhaul infrastructure must be capable of carrying all 43 channels. However, since the P34 voice replacement consists of only one VTG, there is no change between user segments and the backhaul model for this solution. The requirements for these two services are depicted in Figure 19.

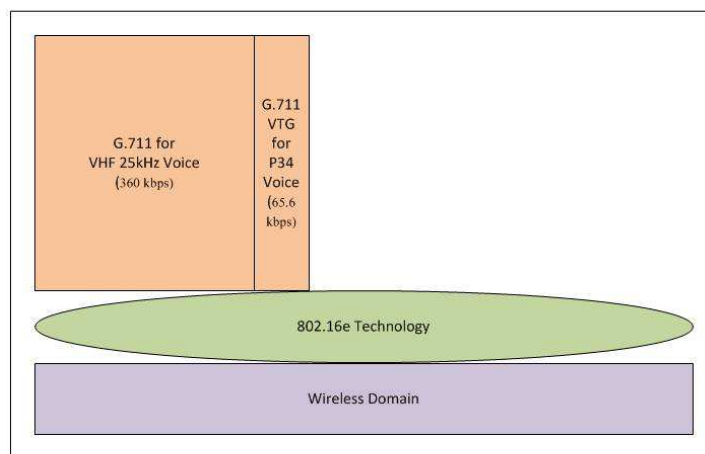

Figure 19. Calculation of VTG Backhaul Segment Bandwidth.

The impact of the PIAC is most pronounced on the resource requirements for transmitting updated positioning data from users to the central database. Although the 3kbps uplink per user has minimal impact within the user segments, the requirement to support a large number of users requires dynamic preparedness. By calculating the maximum PIAC, the bandwidth requirement of 441kbps tremendously overshadows the downlink data. Meanwhile, tremendous fluctuations in positional downlink data and VHF ATS data are minimized through multicasting to compensate for this service requirement. These two services have been updated in Figure 20.

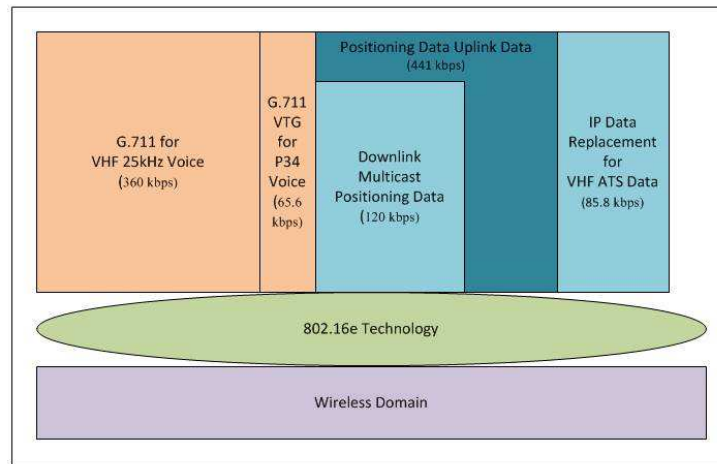

Figure 20. Calculation of IP Data for Backhaul Segment Bandwidth.

The impact of security requirements on the backhaul segments are likely to be increased by the aggregation of the user segments. The availability of a robust transmission backbone on the airfield is also likely to draw other services that have been awaiting the provision of supporting technology. Following the same methodology as the user segment and reserving 20% of the bandwidth for security overhead produces a result of 190.5 kbps and is illustrated in Figure 21.

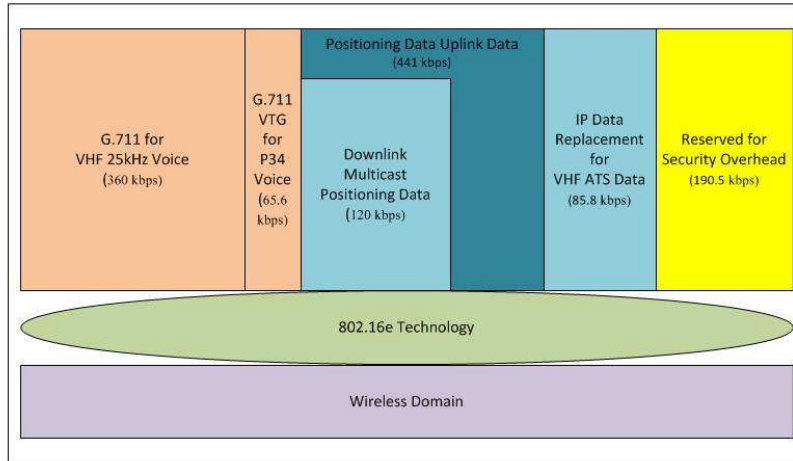

Figure 21. Calculation of Security Overhead for the Backhaul Segment.

The service data rate calculation produces a net result of 1142 kbps. Although the requirement for the backhaul segments is much higher than user segment, demand has been suppressed through the utilization of multicasting. The full data rates supported by a single 10-Mhz 802.16e channel without fractional reuse applied can be found in Table 8. Like the user segments, operation in the minimum 16QAM range requires only 10% of the available bandwidth is devoted to this service with sufficient reserve available in the higher quality ranges.

Mode	Code Rate	Downlink in Mbps	Uplink in Mbps
QPSK	1/2 CTC 6X	1.06	0.78
QPSK	1/2 CTC 4X	1.58	1.18
QPSK	1/2 CTC 2X	3.17	2.35
QPSK	1/2 CTC 1X	6.34	4.7
QPSK	3/4 CTC	9.5	7.06
16QAM	1/2 CTC	12.67	9.41
16QAM	3/4 CTC	19.01	14.11
64QAM	1/2 CTC	19.01	14.11
64QAM	2/3 CTC	25.34	18.82
64QAM	3/4 CTC	28.51	21.17
64QAM	5/6 CTC	31.68	23.52

Table 8. 10-MHz Channel Data Rates without Fractional Frequency Reuse.

At the highest operational range, the solution requires between 30% and 50% of the available bandwidth. However, it is important to note that this is only the available bandwidth

within one of the 10-MHz channels. The ICAO has requested the reservation of up to seven channels; this study has allocated one for user and one for backhaul segments while still retaining 70% of the available bandwidth in reserve for future growth and other applications.

Chapter 5 – Conclusions

User mobility within the national airspace system requires that technology initiatives consider the wider scope of technology solutions. Additionally, user mobility is not limited to U.S. controlled air traffic management segments which necessitate the requirement for worldwide synchronization. Even small technology solutions must be carefully evaluated and considered at multiple locations before adopted for full rate production.

Although aspects of architectural segmentation permit the scale of such projects to be limited, the impact of such changes on the larger architecture must be considered. While the architectural vision of the NextGEN architecture is known, the final results of this document must be synchronized with the current body of work to reinforce the applicability of this project. The initial focus of this synchronization will be to define the relationship of the technology segment boundaries with the adjacent technology segments.

Throughout this project, the limits of the 802.16e service area defined the architectural boundary and demarked the service delivery endpoint. These boundaries are controlled by mechanisms defined and employed through the 802.21 standard to facilitate migration of users from one fabric to another while maintaining communication sessions. These boundaries are illustrated in relation to the service framework in Figure 22.

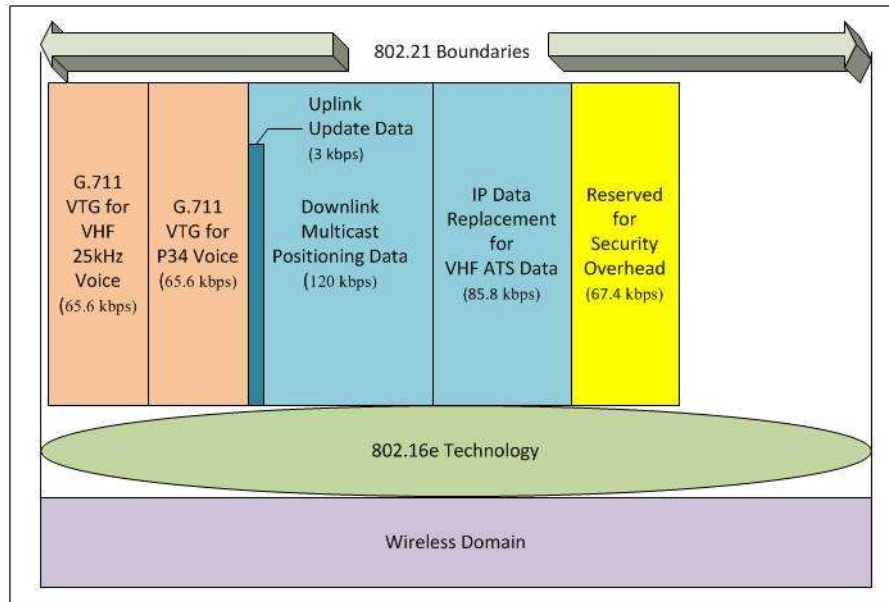

Figure 22. Service Framework Segmentation Boundary.

Although the project was partitioned to achieve this scale, the wireless domain continues beyond the 802.21 boundaries. Once users reach a velocity and range that is permissible to 802.11 session establishment, users are still within the technology domain yet operating in a different segment. Furthermore, the service provider is not likely have the responsibility to support all services that could be beneficial to future operations under the NextGEN vision.

Therefore, some mechanism of offloading these users from the NextGEN architecture and onto privately or joint owned assets will be required. The isolation of certain applications or users during particular phases of flight to these segments would facilitate more stable utilization of 802.16e segments. Such stability is especially important in delivering the high level of life safety that will be required for airfield operations.

Additionally, 802.21 mechanisms could employ QOS applications to ensure some redundancy at localized segments on the airfield by utilizing both 802.11 and 802.16e segments. The exact functionality to control handoff between such segments has not been discussed or presented through research and could be a subject of further study. The extension of the wireless

domain and addition of the 802.11 technology are illustrated in Figure 23.

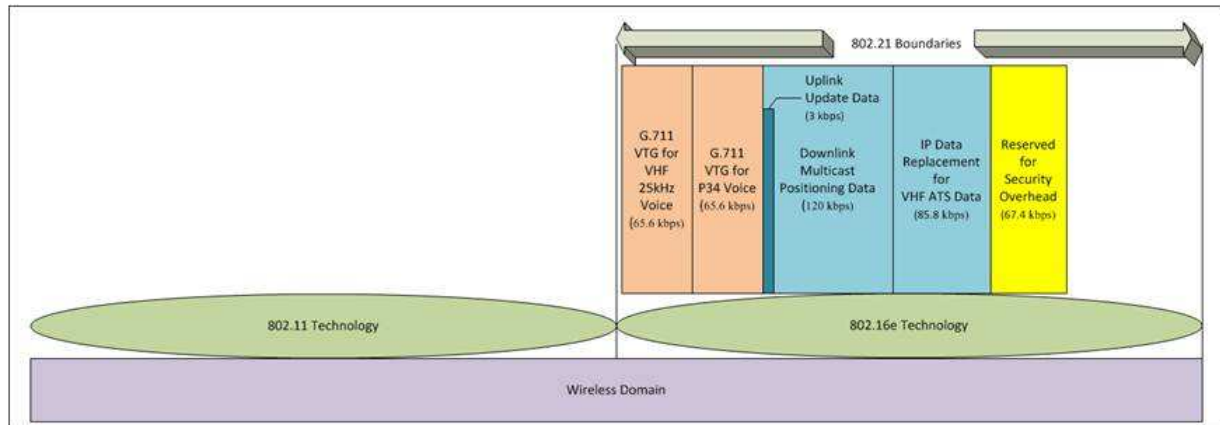

Figure 23. Extension of the Wireless Domain to Include 802.11 Technology.

While the applications within the architectural partition were defined during this study, those within the 802.11 segment fall outside of this scope. Considering that some services may be maintained between the 802.16e segment and the 802.11 segment, ownership of the 802.11 segments appears to be more driven by airline business requirements than the NextGEN architectural vision. For this reason, the full scope of the services that users may require will most likely be handled as an internal matter with the segment developed separately from the primary architecture.

Considering that deployment of 802.11 technologies will not be synchronized with 802.16e initiatives or may never develop the 802.21 boundary could become the service demarcation boundary. Regardless of the outcome, the study results are adaptable since 802.11 technologies are not relied upon as a tertiary solution. However, the deployment of WLAN segments to augment WiMAX is not without merit and does deserve further study.

Similarly, the information transport infrastructure must be continuous to maintain uninterrupted service as user velocity moves beyond 802.16e performance potential. While the specific technology on this border of the architectural partition is not yet defined, it must be

capable of delivering service during transitional periods. Considering that very few technologies will be able to meet the requirement for this segment, the likely candidates will most likely be limited to satellite based technologies.

The most likely events that would trigger the 802.21 handover on this boundary would be user velocity or a reduction in the SNR that results in a corresponding change of the 802.16e signaling mode. This study identified 16 QAM operation rates as optimal for delivering the targeted solution. Further experimentation will identify the SNR at which 16 QAM can no longer be maintained and an 802.21 handover should be triggered.

Furthermore, phases of flight are likely to change faster than signaling rates are capable of triggering an automatic handover. To effect this change, other methodologies should be deployed to trigger changes that may not be optimally controlled by OSI model mechanisms. Addressing service availability at the specific point in time between the takeoff and departure phases of flight is likely to be a very complex task. The service framework depicting the extension into this portion of the technology domain is portrayed in Figure 24.

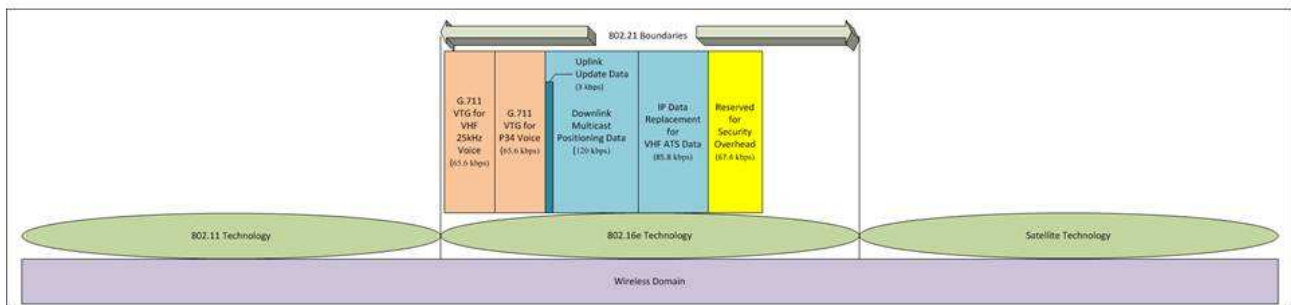

Figure 24. The Wireless Domain with 802.11 and Satellite Technology.

Satellite technology data rates are likely to restrict service delivery in comparison to 802.3 based deployments. Such restrictions will have the greatest impact on unrestrained service delivery across user segments. While the service framework developed within this study was

based on local service delivery, users are unlikely to require the complete service portfolio after the departure phase of flight.

Further study will be required once a transport technology is chosen to determine the optimal service delivery framework for this segment of the technology architecture. The exact methodology to trigger the user session to transverse the 802.21 boundary must also be methodically researched and tested to achieve the optimum quality of service. Additionally, service delivery design for this segment must be conducted in a manner similar to this study to determine which services will be persistent throughout the domain.

Business case justification can significantly change the catalog of services required in this segment of the domain. Furthermore, the contention for access for non-line of sight technology is likely to increase while available user bandwidth diminishes. Finally, the PIAC beyond the airport area will be more congested and complicate bandwidth engineering within this segment to an exponential degree. However, the extension of the technology domain in this manner enables System Wide Information Management (SWIM) as illustrated in Figure 25.

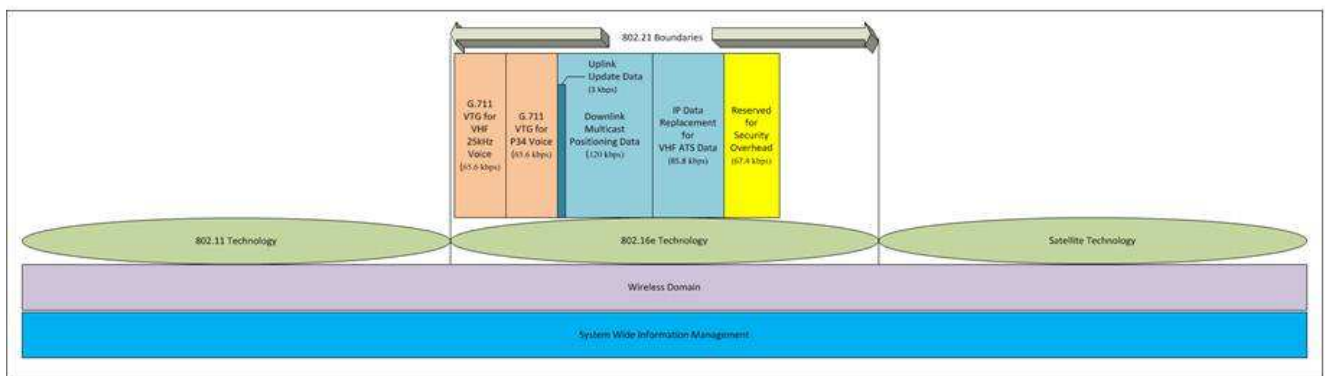

Figure 25. Service Framework Supporting System Wide Information.

The contiguous availability of SWIM is the final requirement to support the concept of a net centric deployment through this partition and the architectural segment. This overarching concept is the final component to enable interoperability between other segments that are

individually developed utilizing the architectural partitioning concept. Ensuring scalability throughout the solution in this manner facilitates further research to refine these components and develop compatible ancillary segments utilizing cost effective methodology.

References

- Abate, Z. (2009). *WiMAX RF systems engineering*. Norwood, MA: Artech House.
- Ashby, S. (2003). The U.S. Air Traffic Management System. *Tech Directions*, 63(5), 18-21.
- Asia and South Pacific Initiative to Reduce Emissions. (n.d.). *Emissions reductions and fuel savings across the entire flight*. Retrieved from <http://www.airways.co.nz>
- Aviation Safety Reporting System. (2010). <http://asrs.arc.nasa.gov/search/database.html>
- Ayaz, S., Bauer, C., Kissling, C., Schreckenbach, F., Arnal, F., & Baudoin, C. et al. (2009, May). *Architecture of an IP-based aeronautical network to integrate satellite and terrestrial data links*. Paper presented at the ICNS Conference, Arlington, VA.
- Bonnefoy, P. A., & Hansman, R. J. (2007). Potential impacts of very light jets on the National Airspace System. *Journal of Aircraft*, 44(4), 1318.
- Brudinger, J., Dyer, G., & Bruno, R. (2005, April). *NASA A/G communications technology assessment study; technology pre-screening: Process and evaluation status*. Paper presented at the ICAO ACP WGC-9, Montreal, Canada.
- Bucher, N. (2000). *The air traffic controllers' strike of 1981*. Joliet, IL: University of St. Francis.
- Burbank, J. L., & Kasch, W. T. (2006, May). *An IEEE 802.16/802.11 hybrid TAN architecture for the next-generation NAS*. Paper presented at the ICNS, Houston, TX.
- Cisco Systems. (2003). *Introducing Cisco IPICS*. San Jose, CA: Author.
- Crane, D. (2007). *Airframe volume 2: Systems* (3rd ed.). Newcastle, WA: Aviation Supplies and Academics Incorporated.
- Dyer, G., & Budinger, J. (2006, September). *FCS technology assessment team: Technology assessment phase II - P34 overview*. Paper presented at the ICAO WGC Meeting, Brussels, Belgium.

- Dyer, G., & Platt, P. (2006, May). *FCS technology investigation overview and status*. Paper presented at the ICNS Technologies Conference & Workshop, Houston, TX.
- Eftekari, R. (2005, September). *Communication and automation transformation challenges for the future air transportation system*. Paper presented at the NEXTOR's NAS Infrastructure Management Conference, Alexandria, VA.
- Eldredge, L. (2009, May). *FAA global navigation satellite system (GNSS) program plans and status*. Paper presented at the ICNS Conference, Arlington, VA.
- European Organization for the Safety of Air Navigation. (2009). *IEEE 802.16e system profile for FCI's airport surface operation* (1.2 ed.). Brussels, Belgium: Author.
- Fallows, J. (2002). *Free flight; Inventing the future of travel*. New York: Perseus Books Group.
- Gilbert, T. J., & Budinger, J. M. (2007, May). *FCS technology investigation status*. Paper presented at the ICNS Conference, Herndon, VA.
- Government Accountability Office. (2005). *National airspace system* (05-331). Washington, DC: U.S. Government Printing Office.
- Grela, J. B. (1978). *Report in the accident involving aircraft Boeing 747 PH-BUF of KLM and Boeing 747 N 736 PA of PANAM*. Madrid, Spain: Ministerio De Transportes Y Comunicaciones.
- Griffith, J. (1998). *Free flight phase I*. Unpublished manuscript.
- Hall, D., & Budinger, J. (2007, May). *Status of the NextGEN ATS CNS test bed*. Paper presented at the Integrated Communications, Navigation and Surveillance Workgroup, Herndon, VA.
- Heseltine, B. P. (2007, Winter). Analysis: KC-135 lean fueling operations. *Air Force Journal of Logistics*.

- Hughes, D. (2004). A joint ATM vision. *Aviation Week & Space Technology*, 160(6), 49-50.
- ITT (2009). *ADB-S explained*. Retrieved November 24, 2010, from www.itt.com
- Inoguchi, K., & Suzuki, Y. (2008, May). *Methodology for the calculation of AMS(R)S spectrum requirements*. Paper presented at the ICAO Aeronautical Communications Panel, Montreal, Canada.
- Integrating UAVs into our airspace is a multi-faceted challenge. (2006). *Aviation Week & Space Technology*, 166(6), 55.
- Ivancic, W. (2006). *Modular, cost-effective, extensible avionics architecture for secure, mobile communications over aeronautical data links*. Paper presented at the IEEE Aerospace Conference, Big Sky, MT.
- Knight, J. (2007). The glass cockpit. *Computer*, 40(10), 92-95.
- Koodli, R. S., & Perkins, C. E. (2007). *Mobile internetworking with IPv6: Concepts, principles and practices*. Indianapolis, IN: John Wiley & Sons.
- Kramer, L., & Busquets, A. (May 2000). *Comparison of pilot's situational awareness while monitoring autoland approaches using conventional and advanced flight display formats*. Hampton, VA: NASA.
- Larsen, E., & Carbon, S. (2005, August). *Modeling of risk to aircraft from space vehicle debris*. Paper presented at the AIAA Atmospheric Flight Mechanics Conference and Exhibit, San Francisco, CA.
- Lockheed Martin Corporation. (2008). *Integrated airport; A NextGEN test bed*. Retrieved from Lockheed Martin Corporation: www.lockheedmartin.com
- Mitchell, T. (2006). *Boeing airport wireless*. Unpublished manuscript, Crew Information Systems, Boeing Commercial Airplanes, Seattle, WA.

Murray, D. P., & Ellis, R. E. (2007). *Air traffic considerations for future spaceports* [Report].

Washington, DC: Federal Aviation Administration.

NASA. (2006). *First order analysis of required bandwidth for the next-generation aeronautical data link*. Retrieved from www.nasa.gov

National Transportation Safety Board (n.d.). *Most wanted transportation safety improvements; Aviation issue areas*. Retrieved September 29, 2009, from <http://www.ntsb.gov>

National Transportation Safety Board. (2006). *Accident Report NTSB AAR-07-05 PB2007-910406*. Washington, DC: Author.

Nolan, M. S. (2004). *Fundamentals of air traffic control* (4th ed.). Belmont, CA: Cengage Learning.

Osborn, K. (2008). *Superfast Blue-Force tracking*. Retrieved from <http://www.defensenews.com/story.php?i=3767827>

Piece of cake (2006, October 2). *Aviation Week & Space Technology*, 14.

Pouzet, J. (2007, May). *Future communications study*. Paper presented at the ICNS Conference, Herndon, VA.

Sherry, L., Feary, M., & Medina, M. (2009). *Standards for human computer interaction (HCI) for NextGEN high density operations*. Unpublished manuscript.

Souders, C. G., & Showalter, R. C. (2008, January). *Transformation of NAS to NextGEN and FAA weather architecture impacts: An update*. Poster session presented at the 13th Conference on Aviation, Range and Aerospace Meteorology, Washington, DC.

Stacey, D. (2008). *Aeronautical radio communication systems and networks*. Hoboken, NJ: John Wiley and Sons.

The FAA has selected (2006, October 2). *Aviation Week & Space Technology*, 16.

Williams, J., Hall, W., Aloke, R., Phillips, B., & Henriksen, S. (2009, August 7). *Airport surface wireless communications terms of reference* (Radio Technical Commission for

Aeronautics). Washington, DC: Author.

Yasin, R. (2010, April 22). How FAA left the high-risk behind. *Federal Computer Week*.

Retrieved from <http://fcw.com/articles/2010/04/22/faa-enterprise-architecture.aspx>

Zhang, Y., & Hsiao-Hwa, C. (2008). *Mobile WiMAX: Toward Broadband wireless metropolitan area networks*. Boca Raton, FL: Auerbach Publications.

Annotated Bibliography

Abate, Z. (2009). *WiMAX RF systems engineering*. Norwood, MA: Artech House.

WiMAX RF Systems Engineering is primer on 802.16 technology and the related principles. The text covers the IEEE standards and doctrine utilized to design and deploy a network centered on utilization of WiMAX for access or distribution. A significant amount of the latter chapters are focused on in depth calculations required to design networks that are robust and deliver high quality of service.

While the text is compact and straightforward, it is not a standalone text for designing 802.16 networks. A significant level of additional information is required to complete a robust design and functional system. For instance, tasks such as site surveying and acceptable signal strengths are not discussed at the depth required for the construction of a deployable model. However, the book presents a specialized resource to aid in the creation of a technical architecture model.

Ashby, S. (2003). The U.S. Air Traffic Management System. *Tech Directions*, 63(5), 18-21.

Mrs. Ashby is a professional educator that wrote this article for the purpose of providing other educators with information concerning the Air Traffic Management System to share with their students. She gives an overview of the hierarchy of the system, which she refers to as a “multi-layered system of sophisticated human-computer interactions.” Key among this interaction is the part that controllers play during their shifts operating in different control facilities. Additionally, the article includes information concerning the coding of flights that are used throughout the control procedures and how such coding correlates with the human interaction regarding the flight.

Although the article is several years old, the information has not changed significantly and is good introductory material for readers that do not have a significant air traffic control (ATC) background. Furthermore, the article includes additional Internet resources that provide more detailed information concerning ATC for the same audience.

Asia and South Pacific Initiative to Reduce Emissions. (n.d.). *Emissions reductions and fuel*

savings across the entire flight. Retrieved from <http://www.airways.co.nz>

The Asia and South Pacific Initiative to Reduce Emissions (ASPIRE) is one of the leading coalitions concerned with the optimization of airport operations. The goals of these optimized operations are to make business transactions more profitable for airports and airline operators while conserving resources. Significant research is available to support the business model in addition to specific fuel consumption and emission reduction figures.

Although some of the initiatives that are components of the ASPIRE approach are not unique to their organization, they have collected them into a unified business model. Considering the

economy of scale in airline operations and the effect that rising fuel costs have on profitability, it is likely that many more organizations will champion such procedures.

Aviation Safety Reporting System. (2010). <http://asrs.arc.nasa.gov/search/database.html>

The purpose of the Aviation Safety Reporting System is to provide a source for data collection of aviation related incidents. The site and database are maintained by NASA rather than the FAA or NTSB to ensure that the submitting parties do not face retribution for reporting nor investigation. Incredibly precise search options are available that permit a researcher to target specific incidents and conduct trend analysis.

The primary strength of the database is that reporting is voluntary and no action is taken against the parties involved. The primary goal is air safety improvement through the identification of trends that can be reduced through policy updates and procedural execution. While the results of the database are robust, it may fail to capture incidents that are not reported due to lack of awareness or fear of reprisal.

Ayaz, S., Bauer, C., Kissling, C., Schreckenbach, F., Arnal, F., & Baudoin, C. et al. (2009, May).

Architecture of an IP-based aeronautical network to integrate satellite and terrestrial data links. Paper presented at the ICNS Conference, Arlington, VA.

This presentation is a commercial research proposal to address the employment of satellite based infrastructure to support disjointed architectural elements in aeronautical communication networks. More specifically, the researchers sought solutions for security and quality of service difficulties that would be encountered when utilizing the expanded architecture. As an architectural planning element, the topics of mobility and security are addressed as well as the author's ideas of how data link selection can be best accomplished.

Although this presentation is a commercial offering, it does present some exceptional applications that could be utilized within the NextGEN architecture. However, considerations such as maturity and cost are not as pervasive as in the FCC studies. This line of study has a very appropriate place in planning for future capacity and possibility when forming the foundation for the future architecture but engineering economy must still be thoughtfully applied.

Bonnefoy, P. A., & Hansman, R. J. (2007). Potential impacts of very light jets on the National Airspace System. *Journal of Aircraft*, 44(4), 1318.

These authors estimate the impact that the entry of very light jets (VLJs) will have on the traffic patterns. Furthermore, the authors narrow the traffic to regions for further study utilizing FAA traffic management data to extrapolate on which portions of the National Airspace System

(NAS) infrastructure would experience the most performance degradation as the utilization of VLJs increased. The author's conclusion is that the ATC elements servicing core regional airports will reach saturation from the traffic and offer the possibility of other airports managing the increased demand.

Although this article is three years old, VLJ traffic has not been the one factor that has led to the demise of the current NAS infrastructure's utility. However, due to cautionary predictions such as the authors the integration of such traffic into the NAS has been carefully monitored and controlled. Market conditions rather than the utility of VLJs over FAA Part 121 and 135 carriers have slowed the need for integration of large numbers of aircraft.

Brudinger, J., Dyer, G., & Bruno, R. (2005, April). *NASA A/G communications technology assessment study; technology pre-screening: Process and evaluation status*. Paper presented at the ICAO ACP WGC-9, Montreal, Canada.

This paper was presented by a joint working group from the NASA Glenn Research Center and ITT industries to the ICAO as an attempt to solidify a global solution to VHF saturation. According to the study, the problem is most severe in Europe and parts of the US, but the solution should be a global solution endorsed by the ICAO Aeronautical Communications Panel (ACP). The study includes a very broad range of technologies considered as well as the operational thresholds for consideration.

The paper provides a very thorough deliberation of a wide range of technologies to include proprietary and military specific solutions. By providing a solid foundation for selection criteria, the authors produced an effective framework for later selection. Of special interest for this study are the cost criteria of the communications and avionics infrastructure.

Bucher, N. (2000). *The air traffic controllers' strike of 1981*. Joliet, IL: University of St. Francis.

This is a short article written by an undergraduate student as part of a final course project involving the implications of the strike. The document is a surface level investigation that provides specific information with some background behind the actions taken by the parties on both sides of the strike. Considering that published information regarding the strike is somewhat limited, this resource is a good primer for the immediate activities surrounding the event.

Upon doing further research, other experts would argue that this document does not present all of the facts and evidence that were involved in the strike. However, it does confirm key facts without speculating on scenarios that are debated or could not be confirmed.

Burbank, J. L., & Kasch, W. T. (2006, May). *An IEEE 802.16/802.11 hybrid TAN architecture for the next-generation NAS*. Paper presented at the ICNS, Houston, TX.

Burbank and Kasch are Johns Hopkins university researchers that introduce the current state of NAS research. The 802 family of technology is also introduced to the audience assuming that the aeronautical specialists have minimal background in its application. The focus of the session is to convey the benefits of adopting hybrid 802.11 and 802.16 architecture at the airport surface within the NAS for to support the future architecture.

Considering that this is an earlier work in the focused period of research, the researchers focused on considering the technology on the shortlist of future contenders for transport technology. Development of proposals for desired services and feasibility studies were considered as an area of future work.

Cisco Systems. (2003). *Introducing Cisco IPICS*. San Jose, CA: Author.

This Cisco book presents the features and benefits of Cisco IP Interoperability Collaboration System (IPICS) to enable communication throughout an organization utilizing vastly different platforms. IPICS is a router based system that offers an enterprise level solution that brings together a wide range of technologies. The book closes with a small network topology that shows the components of a typical deployment.

Although a typical deployment is covered in the text, the solution is very adaptable to a wide range of scenarios. A full set of Solution Reference Network Diagrams (SRND) are available online to compliment the text for this purpose.

Crane, D. (2007). *Airframe volume 2: Systems* (3rd ed.). Newcastle, WA: Aviation Supplies and Academics Incorporated.

Dale Crane is considered by many in the aviation industry to be one of the leading experts on aviation maintenance topics. The book is heavily illustrated to convey the relationships inherent with conveying the knowledge required for aviation maintenance personnel to understand. The subject matter for this volume is focused on the airframe system topics that are a component of the FAA subject tests for aviation mechanics.

This book is an exhaustive resource for those interested in aviation systems or studying for the FAA aviation mechanic's test. The topics covered are well researched and considered throughout the aviation industry to be authoritative on the topic of basic aviation system functionality.

Dyer, G., & Budinger, J. (2006, September). *FCS technology assessment team: Technology assessment phase II - P34 overview*. Paper presented at the ICAO WGC Meeting, Brussels, Belgium.

The FCS technology assessment team is responsible for evaluating equipment utilized or proposed for future use within the NAS. This report specifically focuses on the current status of Public Safety Radio (P34). An overview of the P34 standard is given along with its evolution and current utilization in the technology architecture

Public Safety Radio was significantly neglected during early architectural vision development documents and this presentation placed it back into the proper perspective. Follow on studies considered the impact that transitional architectures would have on the capability of users that rely solely on this band.

Dyer, G., & Platt, P. (2006, May). *FCS technology investigation overview and status*. Paper presented at the ICNS Technologies Conference & Workshop, Houston, TX.

This paper is a status update that is sporadically presented at ICNS conferences to update attendees on joint FAA, Eurocontrol, and NASA studies. The primary tasks outlined in this specific update are pre-screening, investigation, and simulation of technologies for new mobile communication systems. The researchers recommend that technology solutions be investigated to relieve congestion in current air to ground networks.

One of the recommended activities most vital to this study is the detailed simulation of 802.16e performance at the airport surface. This research was conducted by Ohio University and produced favorable results to proceed with deploying the technology.

Eftekari, R. (2005, September). *Communication and automation transformation challenges for the future air transportation system*. Paper presented at the NEXTOR's NAS Infrastructure Management Conference, Alexandria, VA.

Dr. Eftekari discusses the current air traffic levels in contrast with historical levels as well as NASA predictions of future growth. This future growth is categorized by different operational segments and gives projections both by segments and regionally. In addition to the traffic growth information, the presentation translates the impacted growth into the effects that such growth will have on the NAS communications infrastructure.

This paper very effectively presents the thresholds of the current infrastructure in relationship to rising traffic levels through extensive study of traffic patterns. Dr. Eftekari also shares the evolution of different rates of modernization and the impact that each course could have.

Eldredge, L. (2009, May). *FAA global navigation satellite system (GNSS) program plans and status*. Paper presented at the ICNS Conference, Arlington, VA.

Mr. Eldredge presents the GPS architecture as it relates to the National Airspace System capabilities, services, and systems. The focal point of the paper is to discuss the relationship of the two major GNSS enhancement programs that are part of the NextGEN architecture. The Wide Area Augmentation System (WAAS) and Local Area Augmentation System (LAAS) are not only related to technical aspects of the architecture, but the business processes that they support; in this case the phases of flight.

The GNSS segment is a key component of the architecture and is vital to developing or modifying objects from the repository. Furthermore, Mr. Eldredge recognizes that GNSS should be delivered as a service rather than just US based GPS to ensure open source architecture.

European Organization for the Safety of Air Navigation. (2009). *IEEE 802.16e system profile for FCI's airport surface operation* (1.2 ed.). Brussels, Belgium: Author.

This document contains many of the technical characteristics of WiMAX that are of concern to aviation specific deployments. Eurocontrol also outlines several GO and NO-GO thresholds for system operation based on both IEEE standards and assumptions of modifications that could be made for aviation specific certification. Many of the technical assumptions are based on the Ohio State spectrum studies that were the basis for the FAA proposal for WiMAX as a possible wireless solution.

Although this report is authoritative and updated regularly, the authors are very candid about which areas are in need of further study and where the greatest benefit could be realized. The entire chapter on cost considerations is mostly blank and states that the work needs to be completed. Furthermore, other questions that are not addressed in the IEEE standard are proposed certification profiles to be raised for further study.

Fallows, J. (2002). *Free flight; Inventing the future of travel*. New York: Perseus Books Group.

James Fallows is a self-appointed proponent of general aviation and private aircraft ownership as a platform for more efficient travel. The book covers a variety of topics concerning the operating model of commercial air travel and how positive changes could benefit the general public. However, Mr. Fallows does point out that many of these changes to move away from a hub and spoke mass transit system would be revolutionary.

Although not well known outside of the aviation enthusiast world, the text cites solid research to reach significant conclusions regarding how the aviation industry could better serve the public. It is not likely that such changes are attainable in the near term, but some of the concepts could be substantial business processes.

Gilbert, T. J., & Budinger, J. M. (2007, May). *FCS technology investigation status*. Paper presented at the ICNS Conference, Herndon, VA.

ITT and NASA produced the methodology to screen and evaluate technologies that were applied in later FCS studies. While the initial phases of pre-screening and screening were already complete at the time of the study, the researchers focus on in-depth studies and technology evaluation. The principal product of this research was the identification of suitable infrastructure to support the technology architecture after 2020.

This study is a synopsis of the screening results and includes detailed suitability recommendations. The endorsements are currently being pursued as NextGEN technology components.

Government Accountability Office. (2005, June). *National airspace system* (GAO-05-331). Washington, DC: U.S. Government Printing Office.

The focus of this GAO report is the FAA acquisition of systems to modernize the NAS. Auditors found that most systems that were being pursued as part of the NextGEN program were not meeting their original performance targets in terms of timelines or budget. The most startling revelation was that the original WAAS budget of \$509 million had already been surpassed by over \$2 billion and the system was still in development.

This GAO report became the driving force behind the FAA's adoption of enterprise architecture as a strategy. Additionally, many government organizations continued its use to comply with OMB and GAO guidelines to better control IT modernization projects.

Grela, J. B. (1978). *Report in the accident involving aircraft Boeing 747 PH-BUF of KLM and Boeing 747 N 736 PA of PANAM*. Madrid, Spain: Ministerio De Transportes Y Comunicaciones.

This is the official accident report of the Tenerife airport disaster in 1977 during which two Boeing 747 passenger aircraft collided just after takeoff. With 583 fatalities, the event has remained one of the most tragic incidents in modern aviation. The root factors of the cause were

found to be weather and simultaneous radio transmissions. Additionally, there were many who felt one of the pilots shared a majority of the blame.

Regardless of the outcome, there were many contributing factors that led to the event, all of which are attributable to human-technology interaction. Although the technology limitations present in this incident have been difficult to overcome, a significant number of procedures have been changed to avoid future incidents.

Griffith, J. (1998). *Free flight phase 1*. Unpublished manuscript.

Free flight is the title given to air traffic control methods aimed at reducing the load on aircraft controllers by transferring the management of aircraft to automated systems. This document is the FAA plan for implementing the initial phase of free flight operations in conjunction with the NextGEN architecture. The plan conveys the importance of modernizing the NAS and exploiting the opportunities to meet future goals.

While this document is highly interrelated to the CONOPS for Architecture 3.0 that formed the basis for NextGEN, progress has slowly evolved. Many of the challenges that the modernization plan highlights as serious concerns have still not been successfully addressed.

Hall, D., & Budinger, J. (2007, May). *Status of the NextGen ATS CNS test bed*. Paper presented at the Integrated Communications, Navigation and Surveillance Workgroup, Herndon, VA.

This article gives an update of the NASA projects at Cleveland airport involving the testing of wireless sensors and their integration into the NAS to reduce the requirements for voice traffic on the airport's surface. It further identifies the basic areas in which these services could be integrated into a convergence solution to address NTSB concerns for airport safety. As a final recommendation, the presenters make an early recommendation for 802.16e frequencies that could be reserved and utilized for such convergence.

The authors of this article are on the leading edge of integrating services into the NAS for direct delivery to the aircraft. Until their experiments, such data as weather and runway incursion prevention has historically been conveyed to pilots via voice radio transmissions from the control tower. Such an arrangement is labor intensive for the controllers and has led to the near saturation of the VHF channels used for air traffic control.

Heseltine, B. P. (2007, Winter). Analysis: KC-135 lean fueling operations. *Air Force Journal of Logistics*.

This is a lengthy journal article discussing how lean fueling operations have previously been applied in the Air Force to save significant operating funds. Additionally, the author offers a short case study where the identical business application could save millions of dollars at one Air Force base alone. Additionally, he discusses how the bureaucracy of the organization does not feel the same operational pressures as civil aeronautical operations to conserve fuel but will in the near future.

Rather than being critical of wasteful operations, the overall tone praised the resource saving measures and more were already underway. Although not directly attributed to this article, many cost saving initiatives such as lean fueling have become part of the operational culture in the military.

Hughes, D. (2004). A joint ATM vision. *Aviation Week & Space Technology*, 160(6), 49-50.

Mr. Hughes discusses the approach to improving current air traffic control procedures as well as the technology involved from several different perspectives. These different perspectives are compared and contrasted with the FAA plan for the state of the National Airspace System in 2025, the central goal of which is planning for a 300% increase from current traffic levels. One concern of some interested parties is that the near term enhancements needed for ATM may not be in line with future FAA plans and ignored.

This article being several years old, it is now apparent that the FAA implemented a graduated plan aimed at the achievement of the future NAS within the budget constraints that were in place at the time. However, it is likely that concerns such as this from various stakeholder groups, especially those from the general aviation market, became well integrated into the future plans of the FAA.

Integrating UAVs into our airspace is a multi-faceted challenge. (2006). *Aviation Week & Space Technology*, 166(6), 55.

This is an editorial article that begins by citing that unmanned aerial vehicles will continue to become more complex and the application of such machines will continue to widen their appeal to a greater audience. In turn, UAVs will require management consideration in regards to the impact that they will have on the future of the NAS. Sources from the FAA cite that they only issued two experimental certificates for UAVs during 2006 and that their growth will be controllable.

Although the author of this editorial highlights the FAA's statement that they have developed a plan for integration, they fail to share any significant technical detail. Adding to the complexity is that the Minimum Aviation System Performance Standards are not established since many UAVs can operate with less than the minimum payload of avionics equipment that would be necessary for integration into the NAS. While this could be a challenge for planners, the author fails to highlight any of those challenges or reasonable solutions.

ITT (2009). *ADB-S explained*. Retrieved November 24, 2010, from www.itt.com

ITT is the contractor responsible for the design and fielding of the ADB-S system. This webpage explains the system's purpose and its interrelation with other NAS elements in addition to the advantage that it offers for NextGEN users.

While the system seems nearly guaranteed adoption into the NextGEN in some form, the webpage conveys the information in a manner that seems almost like an advertisement. However, the document is a short primer on this technology that leads to other sources for investigation.

Inoguchi, K., & Suzuki, Y. (2008, May). *Methodology for the calculation of AMS(R)S spectrum requirements*. Paper presented at the ICAO Aeronautical Communications Panel, Montreal, Canada.

This document was produced by the ICAO Aeronautical Communications Panel (ACP) to formalize recommendations for 802.16e frequency reservations. It includes extensive study to identify the available frequencies within the IEEE standard and isolate the channels that do not conflict with current avionics. The study concluded that bands between 5000-5010 MHz and 5010-5030 MHz would be the most viable.

The ACP study effectively identified frequency bands available for WiMAX deployment. Since this document was published in 2006, the FAA and has produced additional studies that have proposed additional frequencies would also be viable candidates.

Ivancic, W. (2006). *Modular, cost-effective, extensible avionics architecture for secure, mobile communications over aeronautical data links*. Paper presented at the IEEE Aerospace Conference, Big Sky, MT.

One of the earlier migration paths considered for the NextGEN architecture was to deliver data over the current VHF data network. Researchers found that this solution lacked the capacity to support scalability and current information security techniques. The purpose of this study was addressing the feasibility to tailor modern security methods to the technology in a cost effective manner.

While the motivation behind this study is rational, it seems that such solutions did not garner much support with stakeholders. Rather than implement systems to address security through

obscurity shortfalls during transitional technology architectures, the stakeholders pursued reaching the target architecture in an iterative manner.

Knight, J. (2007). The glass cockpit. *Computer*, 40(10), 92-95.

Glass cockpit technology is the terminology applied to modern aircraft that rely on information systems to deliver information that was once conveyed by dials and gauges. Mr. Knight discusses how modern avionics systems developed from their predecessors and into the equivalent of complex computers. In addition to the background and evolution, the major system functionality is discussed in addition to the author's prediction of future applications.

This journal article is a good primer for comprehending the connection between aircraft systems and modern computing. The reader can begin to extrapolate some of their own impressions of possible future developments after reading the article.

Koodli, R. S., & Perkins, C. E. (2007). *Mobile internetworking with IPv6: Concepts, principles and practices*. Indianapolis, IN: John Wiley & Sons.

While many organizations have not even begun adopting IPv6 addressing schemes in internal networks, this book discusses how to apply the scheme in a mobile environment. Although there is some material dedicated to the basics of IPv6 for those unfamiliar with the addressing scheme, the focal point of the text is applying it in CDMA and WLAN environments. More advanced topics include IP handovers and route optimization for Mobile IPv4 users.

The text is exhaustive in addressing the requirement for mobility in an IPv6 environment. However, the book is more likely to send the reader towards the answer to their questions than answer them directly.

Kramer, L., & Busquets, A. (May 2000). *Comparison of pilot's situational awareness while monitoring autoland approaches using conventional and advanced flight display formats*. Hampton, VA: NASA.

Kramer and Busquets are NASA research scientists who published this technical study focused on increasing pilot situational awareness by providing additional data directly to the pilot. This data was available in the form of various flight displays that were arranged similar to a standard cargo aircraft but delivered data in a more ergonomic way. The study also introduced errors into the data to investigate which delivery methods the pilot was able to utilize to correct the aircraft's heading.

During the study, pilots showed significantly better response times to errors utilizing the advanced displays. Unfortunately, some of the functionality of these formats will not be possible until the NextGEN ATS is operational.

Larsen, E., & Carbon, S. (2005, August). *Modeling of risk to aircraft from space vehicle debris*.

Paper presented at the AIAA Atmospheric Flight Mechanics Conference and Exhibit, San Francisco, CA.

As the National Airspace System has become more crowded, the risk to aircraft caused by space debris has increased. This research was driven by the destruction of the Columbia and the impact that persistent falling debris had on the operation of aircraft following the incident. While this is a limited occurrence, the possible disruption to the NAS if commercial space flight becomes more financially viable is a considerable possibility.

The data collected for this study may not be representative of each possible incident, but it does highlight the possibility of such events and the likelihood that they could increase in the future. Meanwhile, the probability that the NAS could lose the capacity due to such events and continue to operate at meaningful efficiency is unlikely.

Lockheed Martin Corporation. (2008). *Integrated airport; A NextGEN test bed*. Retrieved from

Lockheed Martin Corporation: www.lockheedmartin.com

The NextGEN test bed is the NASA testing ground managed by the Glen Research Center in conjunction with partner agencies and contractors. Three regional airports in Cleveland serve as the real world test bed for communications, navigations, and surveillance (CNS) systems being considered for application in the NextGEN architecture.

CNS engineering analysis results are published and utilized throughout the future communication studies (FCS) series. The results that are regularly published are incredibly useful in developing future solutions concerning the long term studies at the airports.

Mitchell, T. (2006). *Boeing Airport Wireless*. Unpublished manuscript.

This is an internal company briefing discussing the current state of wireless applications on Boeing aircraft and the future impact that such applications could have. Similar applications in other industries such as public safety are addressed as are a wide range of applications that could benefit from 802.11 and 802.16 topologies being available for aviation operations and generating additional streams of income. The culmination of the report is the application of such technologies on the 777 airframe as well as widening the availability of such services to the

entire fleet and discussing what types of infrastructure would be necessary to support such services.

The author is a licensed PE who, according to this report, has done extensive study into the improvement of 802.11 devices for aviation specific use. The report is one of the few published studies that focus on 802.11 being utilized in this application although it is under consideration. While the standard is not an integrated component of the NAS, Boeing is heavily integrating the technology into their aircraft for proprietary use as well.

Murray, D. P., & Ellis, R. E. (2007). *Air traffic considerations for future spaceports* [Report].

Washington, DC: Federal Aviation Administration.

The authors of this report acknowledge that commercial spaceports have an increasing impact on air traffic management. Hazards to commercial aerospace and space operations are analyzed and the requirement to having formal agreements between agencies responsible for ATM and space operations is discussed. The Oklahoma Space Port is used as an example considering its close proximity to several high density controlled airspaces.

This document was one of the first to highlight the changes that the FAA would need to implement to accommodate ongoing changes in the NAS due to space commercialization. The two disciplines are likely to continue encroaching on each other's typical domains as operational spaces become more condensed.

NASA. (2006). *First order analysis of required bandwidth for the next-generation aeronautical data link*. Retrieved from www.nasa.gov

NASA and ITT published these results from a joint study to calculate the bandwidth required for air to ground data as a NextGEN component. The need for the study was directly identified by the ICAO confirmation that new technical capabilities were required to meet future architectural requirements. Extensive PIAC estimates were calculated to support the study which included the entire airspace under U.S. control.

The results are presented in a transparent manner that permits duplication of the study. Additionally, the large sample group provides a wide range of results that can be applied to a variety of situations without further exhaustive study.

NAS modernization goes into full-rate production. (2005). *Microwave Journal*, (August), 54.

This is a short article that announces that NAS modernization has changed from low-rate to full-rate production. The unnamed author provides a quick overview of what the differences mean for the program in addition to listing a few of the systems that could be replaced within the DoD to

ensure compatibility with civilian avionic equipment. Systems of special emphasis to the author were the DoD Advanced Automation System and Digital Airport Surveillance Radar.

Being a specialty journal, this article is slanted towards the systems that are affected or integrated with microwave systems. The length is also less than a page which further limits the scope of the article to a significant degree.

NATCA and FAA finally shake hands on a contract. (2009, November). *IFR*, 25(11), 3.

The National Air Traffic Controller's Association (NACTA) and the FAA have had long standing disagreements over the manner in which management rules were imposed on the union's workers. The FAA contends that the rules must be imposed to maintain safety in the aviation industry and are for the benefit of all involved regardless of controversy. This article marks the end of a period under which employees were working without a contract due to the inability of the two parties to agree to specific terms.

Although many labor disputes are poorly mitigated or end badly, the current union operates amicably between its members and the U.S. government. As an example, the previous union and many employees were terminated due to their unwillingness to compromise with the FAA concerning difficult topics.

National Transportation Safety Board (n.d.). *Most wanted transportation safety improvements*;

Aviation issue areas. Retrieved September 29, 2009, from <http://www.ntsb.gov>

The National Transportation Safety Board (NTSB) is responsible for identifying root causes of safety related incidents occurring in aviation, highway, marine, pipeline, and railroad industries. The NTSB is equipped to be a watchdog organization of sorts that recommends policy and legislative changes to other government agencies to prevent these shortfalls from becoming trends. The most wanted list of improvements highlights their greatest concerns in each industry that become the focus of many organizations.

Although the NTSB makes recommendations to other agencies, there are times when they lack the authority to direct them to act. Legitimate observations may be very complex problems that require years or decades of research and technological advancement to address.

National Transportation Safety Board. (2006). *Accident Report NTSB AAR-07-05 PB2007-*

910406. Washington, DC: Author.

The NTSB was responsible for determining the root cause of Comair Flight 5191 attempting to take off from the wrong runway in Lexington, Kentucky in 2006. The exhaustive investigation found that the crew lost situational awareness and proceeded to take off runway 26 after being

directed to take off on runway 22. The crew and 47 passengers were killed in the incident and no other causes were determined to have contributed to the catastrophe.

The Comair Flight 5191 tragedy findings are central to the NTSB concerns that current positioning methodologies are insufficient for airfield safety. Changes to FAA procedures were made and implemented as part of the report but the overall architectural changes required to deliver advanced positioning still remain.

Nolan, M. S. (2004). *Fundamentals of air traffic control* (4th ed.). Belmont, CA: Cengage

Learning.

Dr. Nolan writes this regularly updated series of books that are considered by many to be the standard for air traffic control knowledge. Due to this perception in the industry, this text is commonplace in many university classrooms on the subject. The subjects contained span from equipment, technology, and procedures utilized in the field.

Considering this book's depth of air traffic control material, it is a good primer for a variety of subjects in the field. The material is also kept very current due to the reliable revisions attributed to consistent use in the academic environment.

Osborn, K. (2008). *Superfast Blue-Force tracking*. Retrieved from <http://www.defensenews.com>

Blue Force Tracker is the product name of the information system utilized by the Army and Marine Corps to identify units in combat. The system shares positioning information and facilitates communication between units to improve situational awareness during the uncertainty of combat operations. This article in particular discusses recent improvements to make the system more user friendly and increase the available bandwidth.

The mechanics of Blue Force Tracker are similar to those required for the target architectural solution which facilitates a good estimate of what the solution bandwidth requirements will be. The software was also developed by Northrop Grumman who has been involved with NextGEN research.

Piece of cake (2006, October 2). *Aviation Week & Space Technology*, 14.

This is a short half page article that discusses conveys the views of the FAA's safety chief at the time, Nicholas Sabatini. His prediction was that integration of new aircraft such as VLJs and UAVs would be "nothing new for the FAA" and therefore would pose no significant safety concerns if managed properly from the start. On the contrary, West Virginia Senator Jay Rockefeller responds that "our aviation system is not prepared to handle the impact."

While Sabatini's role was to manage the safe operation of aircraft within the responsibilities of the FAA, his conclusion that new aircraft types could be operated safely is accurate. However, Senator Rockefeller highlights an important shortfall in FAA operations by pointing out that projections are contrary to successfully controlling a significant increase in traffic. Furthermore, these remarks highlight the lack of a unified communications infrastructure that was congruent with the purpose of the entire agency's operations.

Pouzet, J. (2007, May). *Future communications study*. Paper presented at the ICNS Conference, Herndon, VA.

This study presents the user requirements that are to be addressed through the study and the limitations under which it is completed. Constraints faced by RF carriers are the particular focus of the study in conjunction with plausible migration plans. The presentation includes detailed planning for activity synchronization between several different working groups and activities.

High level planning activities are presented with significant detail to permit synchronization of activities to align activities of different agencies. The concern of extending the lifecycle of the current architecture to the maximum extent to facilitate smooth architectural transition periods is conveyed as a key strategy.

Sherry, L., Feary, M., & Medina, M. (2009). *Standards for human computer interaction (HCI) for NextGEN high density operations*. Unpublished manuscript.

This presentation is based on the joint research study conducted by NASA and George Mason University regarding Human Computer Interaction (HCI) with the NextGEN architecture. The primary focus of the study was how changes in HCI could affect crew resource management and task execution on the flight deck. The results concluded that effective HCI could save the industry \$447 million in annual operating costs.

Although the outcomes are astounding, the results may prove difficult to achieve in real world scenarios. The additional flight times involved provide excellent insight into how the NextGEN architecture is capable of improving efficiency.

Souders, C. G., & Showalter, R. C. (2008, January). *Transformation of NAS to NextGEN and FAA weather architecture impacts: An update*. Poster session presented at the 13th Conference on Aviation, Range and Aerospace Meteorology, Washington, DC.

This paper was an update to the architectural vision that specifically addressed the requirement for a CONOPS to address weather information. The authors highlight FAA findings that

concluded the current architecture faced serious shortfalls in the detection, prediction, and dissemination of weather information. Significant recommendations are given concerning the integration of National Oceanic and Atmospheric Administration information systems and the FAA to produce a net-centric solution.

The primary author of this document is an FAA employee and serious consideration has been given to her proposals to improve weather situational awareness with NextGEN architectural features. Although this document is a concise 10 pages, the information is well constructed and provides a valid roadmap for future developments.

Stacey, D. (2008). *Aeronautical radio communication systems and networks*. West Sussex, England: John Wiley & Sons.

Dale Stacey is considered by many industry experts to be an authority on aeronautical communication networks. This book describes technology and systems utilized for air to ground and air to air communication in civilian and military applications. The technical explanations are very detailed and provide the depth of information required for complex network engineering.

This book is book is exhaustive but requires that the reader has some background in RF communications or electrical engineering to fully digest the text. It is a vital text for engineering or troubleshooting RF spectrum compatibility in aeronautical RF systems.

The FAA has selected (2006, October 2). *Aviation Week & Space Technology*, 16.

This is a news release that announced that the FAA selected Lockheed Martin's response to their request for proposal to develop a plan to integrate UAVs into the NAS. It outlines the five year program that the contractor will follow to develop a plan that will be presented to the FAA. The primary focus of such planning will be to consider the manufacturing capacity of firms producing such aircraft and predict the increased requirements for the communications systems that comprise the National Airspace System.

Ironically, this article is printed directly adjacent to another article in which the FAA gives predictions and states that the situation is well under control. Given this coincidence, it is likely that the authors wanted to convey that the FAA does not have a significant plan for such communication system requirements.

Williams, J., Hall, W., Alope, R., Phillips, B., & Henriksen, S. (2009, August 7). *Airport surface wireless communications terms of reference* (Radio Technical Commission for Aeronautics). Washington, DC: Author.

This document is a technical report from the Radio Technical Commission for Aeronautics discussing the current status of the development of an 802.16e aeronautical standard. The authors discuss the types of services that may be modeled over the band and propose guidance for future study to develop performance and operational standards to measure the new services.

As the work is awaiting approval of the 802.16e aeronautical standard by the IEEE, most of the work outlined in the open tasks remains to be undertaken. Although the document is short guidance, it is well structured and aimed at a specific technical goal. It is notable that there are an immense number of stakeholders that are interested in the completion of this task and the representation within the scope of this project is not congruent with many other NextGEN and SESAR documents.

Yasin, R. (2010, April 22). How FAA left the high-risk behind. *Federal Computer Week*.

Retrieved from <http://fcw.com>

Mr. Yasin announces that the FAA has managed to remove the NextGEN project from the OMB high risk IT project list after a 14 year streak. Many industry experts contribute this development to the organization's successful implementation of an enterprise architecture strategy. He also highlights the organizational hurdles of successfully adopting EA faced in the FAA.

While the adoption of EA is difficult in any organization, the size and number of vendors involved with the NextGEN project made the mid project transition difficult. However, considering that the final cost will be billions of dollars, accountability and project assurance are a necessity.

Zhang, Y., & Hsiao-Hwa, C. (2008). *Mobile WiMAX: Toward Broadband wireless metropolitan area networks*. Boca Raton, FL: Auerbach Publications.

The authors of this book explore the phenomenon of WiMAX being utilized to serve large metropolitan areas for a profit. The possibility of attracting both mobile and residential customers is presented in conjunction with the approaches that would be required to support such networks.

While many texts are focused on business or technology aspects, the authors address the practicality of both subjects equally well. This text is a good bridge between texts that discuss the idea of profitability and how to actually implement a network that meets business needs from a technical standpoint.

Acronyms

1090 ES	1090 MHz Extended Squitter
802.11	Wireless Local Area Network
802.16	Wireless Metropolitan Area Network
802.16e	Mobile Wireless Metropolitan Area Network
802.21	Media Independent Handover Services
AeroBGAN	Aeronautical Broadband Global Area Network
ACP	Aeronautical Communications Panel (Part of the ICAO)
ADM	TOGAF Architectural Development Method
ADS-B	Automatic Dependent Surveillance - Broadcast
AGCFC	Air Ground Communications Focus Group
AIAA	American Institute of Aeronautics and Astronautics
ANC	Air Navigation Conference
AOC	Airline Operational Communications
AP-17	Action Plan 17
APC	Air Passenger Communications
APU	Auxiliary Power Unit
ASPIRE	Asia and South Pacific Initiative to Reduce Emissions
ASRS	Aviation Safety Reporting System
ATC	Air Traffic Control
ATM	Air Traffic Management
ATS	Air Traffic Service
B747	Boeing 747

B777	Boeing 777
BRU	Brussels International Airport
CNS	Communications/Navigation/Surveillance
CONOPS	Concept of Operations
COTS	Commercial off The Shelf
CSMA	Carrier Sense Multiple Access
DoD	Department of Defense
DTRA	Defense Threat Reduction Agency
EA	Enterprise Architecture
EoIP	Everything Over Internet Protocol
Eurocontrol	European Organization for the Safety of Air Navigation
FAA	Federal Aviation Administration
FAR	Federal Aviation Regulation
FCI	Facility Condition Index
GAA	General Aviation Airplane
GAMA	General Aviation Manufacturer's Association
GBAS	Ground Based Augmentation System
GNSS	Global Navigation Satellite System
GPS	Global Positioning System
HCI	Human Computer Interaction
ICAO	International Civil Aviation Organization
ICNS	Integrated Communications, Navigation and Surveillance
IEEE	Institute of Electrical and Electronics Engineers

IPICS	Interoperability and Collaboration System (Cisco Product)
ITAR	International Traffic in Arms Regulations
ITU	International Telecommunications Union
JIT	Just in Time
LAAS	Local Area Augmentation System
MIH	Media Independent Handover
MOPS	Minimum Operational Performance Standards
NACTA	National Air Traffic Controller's Association
NAS	National Airspace System
NASA	National Aeronautics and Space Administration
NextGEN	Next Generation National Airspace System Architecture
NEXTOR	National Center of Excellence for Aviation Operations Research
NTSB	National Transportation Safety Board
PE	Professional Engineer
PIAC	Peak Instantaneous Aircraft Count
QAM	Quadrature Amplitude Modulation
QoS	Quality of Service
QPSK	Quadrature Phase Shift Keying
RNP	Required Navigational Performance
RTCA	Radio Technical Commission for Aeronautics
SBAS	Satellite Based Augmentation System
SESAR	Single European Sky ATM Research
SG	Steering Group

SNR	Signal-to-Noise Ratio
SOA	Service Oriented Architecture
SRND	Solution Reference Network Diagram
SWIM	System Wide Information Management
TIA	Telecommunications Industry Association
TOGAF	The Open Group Architecture Framework
UAV	Unmanned Aerial Vehicle
UMTS	Universal Mobile Telecommunications System
USAF	United States Air Force
VDL	Very High Frequency Digital Link
VHF	Very High Frequency
VLJ	Very Light Jet
WAAS	Wide Area Augmentation System
Wi-Fi	See 802.11
WiMAX	Worldwide Interoperability Microwave Access, see 802.16e
WLAN	Wireless Local Area Network
WMCDMA	Wideband Code Division Multiple Access

Glossary

P34 The term commonly applied to the Public Safety Radio network and associated equipment.

Part 121 The Federal Aviation Regulation (FAR) that applies to operating requirements for domestic, flag, and supplemental airline operations. The term Part 121 is commonly applied to refer to commercial aviation operations of scheduled air carriers.

Part 135 The Federal Aviation Regulation (FAR) that applies to commuter and on demand airline operations. Sometimes referred to as air taxi services as aircraft regulated under this FAR have nine passenger seats or less.