

## Regis University ePublications at Regis University

---

All Regis University Theses

---

Fall 2010

# Hospital Network Infrastructure: a Modern Look Into the Network Backbone with Real Time Visibility

Homan Mike Hiran  
*Regis University*

Follow this and additional works at: <https://epublications.regis.edu/theses>

 Part of the [Computer Sciences Commons](#)

---

### Recommended Citation

Hiran, Homan Mike, "Hospital Network Infrastructure: a Modern Look Into the Network Backbone with Real Time Visibility" (2010). *All Regis University Theses*. 359.  
<https://epublications.regis.edu/theses/359>

This Thesis - Open Access is brought to you for free and open access by ePublications at Regis University. It has been accepted for inclusion in All Regis University Theses by an authorized administrator of ePublications at Regis University. For more information, please contact [epublications@regis.edu](mailto:epublications@regis.edu).

**Regis University**  
College for Professional Studies Graduate Programs  
**Final Project/Thesis**

# Disclaimer

Use of the materials available in the Regis University Thesis Collection ("Collection") is limited and restricted to those users who agree to comply with the following terms of use. Regis University reserves the right to deny access to the Collection to any person who violates these terms of use or who seeks to or does alter, avoid or supersede the functional conditions, restrictions and limitations of the Collection.

The site may be used only for lawful purposes. The user is solely responsible for knowing and adhering to any and all applicable laws, rules, and regulations relating or pertaining to use of the Collection.

All content in this Collection is owned by and subject to the exclusive control of Regis University and the authors of the materials. It is available only for research purposes and may not be used in violation of copyright laws or for unlawful purposes. The materials may not be downloaded in whole or in part without permission of the copyright holder or as otherwise authorized in the "fair use" standards of the U.S. copyright laws and regulations.

HOSPITAL NETWORK INFRASTRUCTURE:

A MODERN LOOK INTO THE NETWORK BACKBONE WITH REAL TIME VISIBILITY

A THESIS PROJECT

SUBMITTED ON THE 29<sup>TH</sup> OF NOVEMBER, 2010

TO THE DEPARTMENT OF INFORMATION SYSTEMS, INFORMATION TECHNOLOGY,

AND COMPUTER SCIENCE

OF THE SCHOOL OF COMPUTER & INFORMATION SCIENCES

OF REGIS UNIVERSITY

IN PARTIAL FULFILLMENT OF THE REQUIREMENTS OF MASTER OF SCIENCE IN

SYSTEM ENGINEERING

BY

Homan Mike HIRAO

APPROVALS

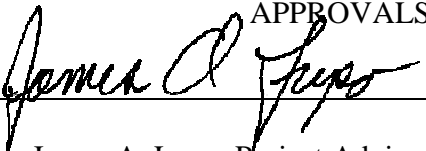
  
\_\_\_\_\_

James A. Lupo, Project Advisor

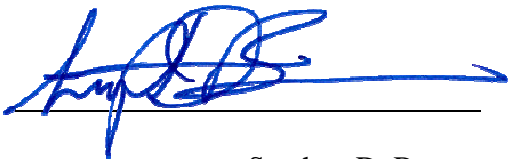
  
\_\_\_\_\_

Stephen D. Barnes

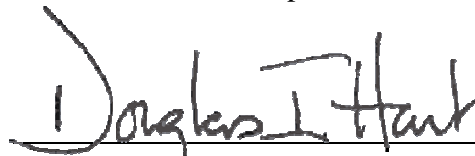
  
\_\_\_\_\_

Douglas I. Hart

**ABSTRACT**

For the purposes of this research, the “design science” discipline of Information Systems will structure the overall methodology and framework for results. By leveraging the design science framework, this study will dissect and analyze various parts of a hospital's network, to uncover substandard practices and problematic weaknesses that commonly result in an overall decrease in the quality of healthcare provided to patients, and negatively affect business operations of hospitals and healthcare facilities. For the purposes of this research the chosen hospital will be categorized as Mid-Western Hospital.

This thesis will investigate, in a real world healthcare organization, fault management technologies in the network design using Dual-MAN architecture. By analyzing current network bandwidth performance and financial data of a health care organization, as it relates to network connection cost, organizations can improve network performance and save money in the process. Additionally, this thesis will propose possible solutions to help manage large health care organizations' network.

## ACKNOWLEDGEMENTS

I would like to take this opportunity to sincerely thank all of those who have helped make this thesis possible. I would like to send special thanks to my advisor Dr. Hart and my thesis advisor Dr. Jim Lupo who contributed to my intellectual development through coursework and assistantship, mentoring that guided me through this entire process. I am extremely grateful for my loving family who has shown more support throughout my entire life than I could have ever wished for. My family has contributed immeasurably to shaping me as an individual as well as a professional; without their influence and encouragement, I would not be the person I am today. Special thanks are also extended to my dearest friends, who have granted me with their continuous guidance, mentoring, and friendship. They taught me that life has its strengths and weaknesses, but how you learn from the weaknesses and live from the strengths is what makes life's journey enriching and rewarding. Also influential in the preparation and completion of this thesis is my distinguished colleagues with whom I shared many ideas. I thank them for creating a friendly and collegial work environment, and for their cooperation. I anticipate my thesis can help both network professionals and prospective students alike, and it would be a corner stone in today's matrix support model.

## **TABLE OF CONTENTS**

**ABSTRACT**

**ACKNOWLEDGEMENTS**

**TABLE OF CONTENTS CONTINUED**

**LIST OF FIGURES**

**LIST OF TABLES**

### **CHAPTER 1**

---

1 INTRODUCTION

1.2 PROPOSAL

1.3 PROBLEM STATEMENT (EXPLAINS PURPOSE OF THE THESIS/PROJECT).

1.4 BACKGROUND (RATIONALE OF THESIS. SHOULD SUPPORT THE PROBLEM STATEMENT. PURPOSE FOR THE STUDY IS CLEARLY DEFINED).

1.5 RELEVANCE TO PROPOSAL (SIGNIFICANCE – SIGNIFICANCE OF THE STUDY).

1.6 HIGH AVAILABILITY AND DISASTER RECOVERY

### **CHAPTER 2**

---

#### **REVIEW OF LITERATURE AND RESEARCH**

2.1 PAST RESEARCH

2.2 WHAT ARE THE THEORETICAL FRAMEWORKS?

2.3 WHAT ARE THE QUESTIONS TO BE ANSWERED?

2.4 HOW HAVE OTHERS ANSWERED THE QUESTIONS?

### **CHAPTER 3**

---

## **METHODOLOGY**

### 3.1 INTRODUCTION

### 3.2 DESIGN AS AN ARTIFACT

#### 3.2.1 DESIGN SCIENCE ARCHITECTURE

#### 3.2.2 STRUCTURE & GUIDELINES.

### 3.3 RESEARCH PROCEDURE (DETAILED STEPS YOU TOOK TO CONDUCT & COMPLETE THE STUDY).

### 3.4 RESEARCH PARTICIPANTS (PEOPLE INVOLVED).

### 3.5 RESEARCH LOCATION (WHERE YOU CONDUCTED THE STUDY. NO NAMES OF PLACES, NO SPECIFICS).

### 3.6 RESEARCH INSTRUMENTS AND MATERIALS (TOOLS USED).

#### 3.6.1 NETWORK PERFORMANCE MANAGEMENT MONITORING TOOLS.

#### 3.6.2 ORION SOLAR WINDS

#### 3.6.3 NETQOS

### 3.7 DATA ANALYSIS (EXPLAIN HOW YOU ANALYZED THE DATA YOU GATHERED)

### 3.8 HOSPITAL NETWORK SECURITY

### 3.9 MISSION CRITICAL CLINICAL APPLICATIONS

## **CHAPTER 4**

---

### **RESULTS AND OBJECTIVE EVALUATION**

#### 4.1 RESULTS AND DISCUSSION (INTERPRET THE RESULTS. THESE ARE YOUR FINDINGS.)

#### 4.2 DATA COLLECTION AND ANALYSIS (DISCUSS THE DATA YOU FOUND & MEANING).

##### 4.2.1 OVERVIEW OF RESEARCH DATA.

4.2.2 ANALYSIS, COMPARISONS, AND RESULTS OF NETWORK PERFORMANCE MONITORING TOOLS.

4.3 ANALYSIS AND COMPARISON OF PREVIOUS INVESTIGATIONS AND RESEARCH FINDINGS. (USE PREVIOUS RESEARCH TO VALIDATE FINDINGS AND CITE THE SOURCE).

4.4 UNANSWERED VARIABLES (ADDRESS AND IDENTIFY UNANSWERED QUESTIONS).

4.5 RESEARCH STUDY LIMITATIONS AND RECOMMENDATIONS. (DISCUSS LIMITATIONS OF YOUR STUDY AND RECOMMEND REMEDIES).

4.6 DISCUSSION OF BARRIERS AND UNKNOWN VARIABLES OF THE RESEARCH.

## **CHAPTER 5**

---

5 CONCLUSION

## **CHAPTER 6**

---

REFERENCES



List of Figures

Fig 1 Current Mid-Western Hospital MAN Diagram

Fig 2 Example of a mass email notification of planned network outage

Fig 4 Improved Dual-MAN network Diagram 24/7 Redundant connection

Fig 5 Orion Solarwinds Network the new Dual MAN

Fig 5-2 Screen shot of solarWinds network market map

Fig 6 Division WAN diagram from Solarwinds June 2010

Fig 7 Solarwinds Netflow diagram showing 15 minute Increments

Fig 8 Traffic view of top 5 talkers on the network

Fig 9 Example of diagram Top 10 sources by Utilization

Fig 10 Network diagram that shoes NetQoS core infrastructure

Fig 11 Powerful tool within NetQoS Report Analyzer for network optimization

Fig 12 Example of Meditech (mission critical clinical application) bandwidth across the WAN

Fig 13 Netflow of various protocols on the Mid-Western Hospital network (reporting comparison)

Fig 14 NetQoS Report Analyzer Network Latency diagram

Fig 15 Example of Automatic Email notification alert

List of Tables

Table 1 Mid-Western Hospital 2009 Example Monthly Circuit Costs

Table 2 Estimated total monthly Market MAN/WAN costs 2010

Table 3 2010 Example MAN/WAN costs

## Chapter 1

### 1 Introduction

With an ever-growing need for healthcare and healthcare facilities, large hospitals and their subsidized branch facilities are demanding more stable and reliable sources for network solutions. The field of Information Technology and Network Infrastructure Management has become crucial components within the healthcare industry. Today, many hospitals, clinics, and outpatient care providers are taking full advantage of the benefits that modern technological advances have to offer.

#### 1.2 Proposal

The object of this research is to lower the total cost of ownership and increase network performance for Mid-Western Hospital, by deploying a dual MAN (metro area network) and using a cost efficient network management Simple Network Management Protocol (SnMP) tool to monitor and manage the dual circuits. The current network design of Mid-Western Hospital is not fully redundant connection and is over 65% utilized and not optimized. The plan of the dual circuits are more improved total cost of ownership by getting rid of clustered expensive T1 lines to the 20 clinics, and moving them over to the new Dual-MAN faster network. The Dual-MAN is two fast Ethernet Optical Connections from two service providers that will provide full fault-tolerant network connection for increased high availability.

Through this study, certain facets of a hospital's network and core infrastructures will be examined. The thesis is comprised of two parts that will be evaluated and divided into two main sections: the first will uncover network design upgrades and the second will show a comparison

of network performance monitoring systems; the management of a hospital's network performance will be discussed and analyzed. Monitoring application response times, network traffic compositions, infrastructure health and performance, early warning alerts and packet-level diagnostics will make the network more visible and ultimately increase proactive detection and resolution of network devices such as Switches.

Ultimately, the healthcare organization has to consider the upfront costs (hardware and software) and future expandability. Customizable capacity planning, trending tools, and application response time monitoring provide projection charts over various time periods. The charts provided in this study will illustrate how the network environment changes for each application response time and provide network traffic analysis and device performance.

Network dissection and reporting are also vital parts of the network upkeep and maintenance. Further analysis within this study will provide a more detailed review of hospital network protocols, networking systems, and security as it relates to healthcare hospital networks.

### **1.3 Problem Statement**

Large hospitals such as Mid-Western Hospital face a varying degree of problematic hot spots that impede the quality of healthcare to patients and overall business operations of the hospital and healthcare facilities. Mid-Western Hospital has multiple facilities networked together make it difficult to pinpoint the origins of various problems that interrupt business operations and decrease the quality of care to patients. These problems experienced by the hospital vary from issues such as network hesitation and slowness to outages. Due to the fact that there is an overwhelming amount of varying data and problematic occurrences, this can

consume large amounts of time and resources for administrators to detect and isolate problems within a large clustered network.

As a result, hospitals and healthcare facilities will experience delays in overall performance in mission-critical environments such as emergency rooms, operating rooms, and intensive care units. Administrative performance and functionality will also be negatively affected as more time will be needed to research, implement, and deploy a solution to resolve these issues. Problematic delays and over-consumption of network resources will harm the overall quality of clinician care, as well as the on-going business operations of hospitals and clinics.

Administrative costs will also drastically increase as problematic events occur on a consistent basis. Ultimately, rather than allocating private and government funding toward increased quality of patient care, hospitals are directing this much needed funding to their IT and administrative departments to resolve these problematic occurrences. Additionally, the time and resources of hospital staff are drastically consumed by these network problems. The over-consumption of time and resources does not only apply to just hospital IT departments, however, as the effects can be felt by doctors, nurses, and on-sight clinicians, as well.

#### **1.4 Background Research**

Operational standards can be improved by evaluating the technology and methods that are currently implemented within hospital networks (Gibbs & Quillen, 2007, p. 8).

There are various technologies and methods in which the implementation of a network would allow for high-speed access. For this instance, a reliable Dual-MAN network architecture was chosen to connect all of the medical centers together. The implementation of the MAN network

allows a healthcare center to use high-speed, reliable fiber-optic networks. This is not only beneficial because of the information sharing that can exceed access across multiple sites and even allow for information sharing across the nation, but it is also cost effective; physicians can access information which is not limited to their physical location. In addition, the dual-MAN architecture has the capabilities to maintain the required bandwidth support for the exchange of large files across the network. (Gibbs & Quillen, 2007, p. 54).

### **1.5 Relevance to Proposal**

The objective of research in hospital network engineering is to acquire knowledge and understanding to improve the current network shortcomings that impede the current overall operations of hospital networks. Examples of these problems include, but are not limited to: no network redundancy, the absence of network performance monitoring tools within the market, lack network of availability, and network latency or congestion. According to Howard Quillen and Mike Gibbs (2007), authors of “The Medical Grade Network: Helping Transform Healthcare”:

Several decades ago, single physician treated all of a patient's various illnesses today; a patient receives treatment from multiple physicians and clinics. This creates the need for medical and clinical information to be shared securely among many healthcare entities. To provide the framework for this new healthcare world, a connected knowledge support, and process optimization are all parts of the system where information is quickly and reliably exchanged. (p. 3).

Currently, large hospitals are utilizing network design infrastructures that are slow and expensive. For the purposes of this thesis the term “design infrastructure” will refer to the

framework for designing the network. The network performance is vital to the functionality of hospitals and prioritization of resources is crucial to the overall uptime performance and functionality. When resources are allocated improperly, the performance depreciates. As a result, the overall cost to manage and maintain these complex networks can be extremely expensive. The cost will perpetually increase as more dedication is spent on maintaining inefficient designs of complex networks.

Please refer to Figure 1 from the diagram. It is evident that the current network is 85% utilized. At Mid-Western Hospital MedicalCenter1, the network is currently running at 60% with a WAN speed of only 6Mbps. This is evidence to support the fact that hospital networks are experiencing problems of network slowness and inefficiency. Current networks for many large hospital organizations that are experiencing this lack of performance need to take action and upgrade the circuit to maintain application performance. Based on this use case, we can assume that the performance and overall business operations will be compromised.

In order to get approval from the CIO and CFO of the Mid-Western Hospital, cost-benefit savings and network performance enhancements had to be presented. The higher the bandwidth the lower the total cost of ownership, and in the end the cost savings will exceed \$150,000 a year just in this division by getting rid of expensive bundled T1 lines for parasite clinic hubs. These parasites hubs that are the 20 clinics that are mostly open for business from 8AM to 5PM. It will also improve bandwidth by 60% for these various clinics, a significant increase from the previous design. Cost is cumulative all 24/7 hospital facilities should have full redundancy at all levels at all times. The savings will be concluded by getting rid of these expensive and slow bundled T1 lines and moving them on the new dual MAN architecture.

The Mid-Western Hospital network uses two primary providers, Qwest and Time Warner, as primary and secondary circuits. If the primary path (Qwest) circuit fails for any reason, the other backup circuit (TW) will route ingoing and outgoing traffic seamlessly. By upgrading the Qwest circuit, Mid-Western Hospital networks can save over \$150,000 a year by eliminating excess T1 lines. The proposal will upgrade the two provider circuits with fast optical Ethernet; the qwest circuit is 100Mbps and the Time Warner circuit is a 200Mbps. Generally speaking, Time Warner has a better customer service; this is vital when it comes to alerting and pushing out notifications to their customers and their technicians to expedite and correct outages on the circuit. Therefore, the communications carrier that we will be eliminated will be AT&T, because this is part of the old network service provider.

The current design of the hospital MAN network is slow and expensive, and consequently, it became apparent to redesign the network infrastructure for this division. Since this large hospital chain is a nationwide organization, all plans will have to get approved from various executives, managers, and board members. Network Engineers will also need powerful tools to monitor in real time and to help manage the network. The proposal will need to be well thought out, and the new design will have to incorporate 24/7 redundancy at all levels for high network availability.

### **Current MAN Network Diagram:**



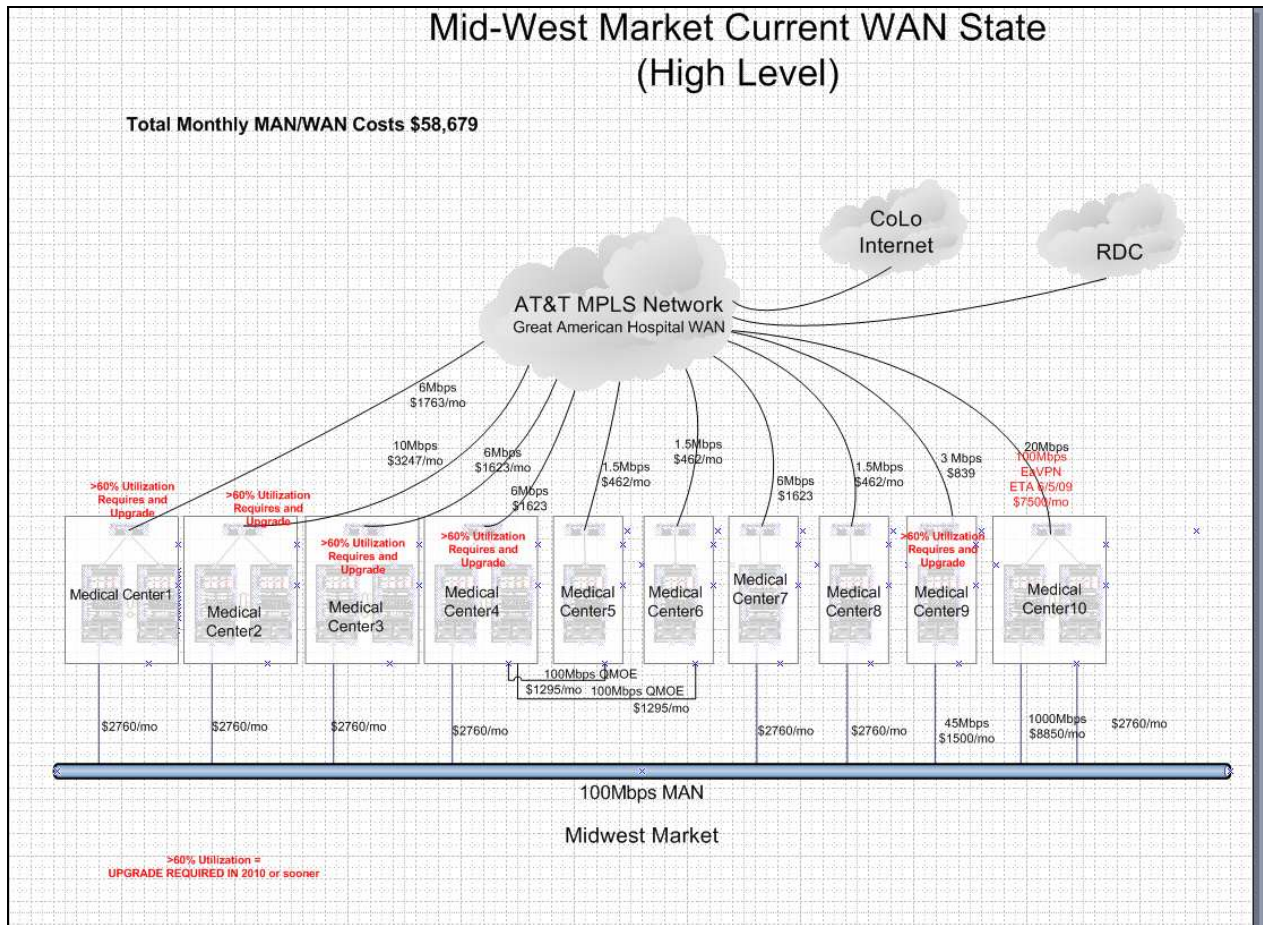

Fig 1 shows example of the current MAN with no redundancy or failover fault tolerance.

The design should take into consideration business continuity and minimize risk and plan for disasters. According to the *Journal of World Health and Societal Politics* (2007), “The continuity of Business is vital in any setting and even more so in hospitals where the product is literally life and death” (Keene & Auger). When it comes to planning and designing a fully redundant network, it is important make certain the service providers have backup power sources such as diesel generators and ensure physical redundancy as well as physical diversity in your cable runs (Johnson, 2003, p. 35). The Network Upgrade Coordinator has a specific role and responsibilities that apply to the upgrade project. The timeline to implement and complete this

proposal encompasses approval, research, planning, and testing through go-live date. Once the network is live on the new dual-MAN, the daily operational network leader assumes responsibility on managing the live environment as documented. The role of the network engineer upgrade coordinator is to be the project manager during the upgrade process and is the liaison between all facilities within the network. The network upgrade coordinator is responsible for all activities described to ensure a smooth and successful upgrade, go-live day, and transition to the daily business operations. Administrative support from the facility CIO and other managers is vital to the overall success of the upgrade. Communication is critical to the overall success of the network upgrade, by keeping hospital personnel informed as to the status of the upgrade on a regular basis. My role in the network upgrade project is gathering pricing information from circuit provider vendors and presenting this information to our network engineers and the company CFO. This contribution assisted in solving the company's problem by saving money and having full redundant network.

### **Upgrade Process Overview**

This section provides an overview of the 4 major milestones in the upgrade process:

- I. Getting Ready by preparedness, planning the circuit upgrades and planning proper facility notifications
- II. Order the new circuits
- III. Go-Live and test fail over
- IV. Disconnect AT&T the MAN\WAN circuits and get rid of the additional bundled T1 lines.

Task completed UPGRADE COMPLETED.

**This is the process to upgrade to a dual-man hub configuration.**

- The plan is your friend.
- Use all the tools provided.
- Milestones must be completed
- Team to attend mid-upgrade status call
- Conduct integrated testing
- Best practice testing
- Maintain current software
- Complete all activities prior to go/no go call
- Validate your parameters

**Upgrade Management**

- Team needs access to available resources
- Create process to share upgrade related material
- Questions to be routed through network upgrade coordinator
- Establish issue tracking process
- Follow best practices for reporting issues
- Team needs access to available resources
- Create process to share upgrade related material
- Questions to be routed through network upgrade coordinator
- Establish issue tracking process
- Follow best practices for reporting issue.

Hospitals and the healthcare industries are seeing a more growing demand for a better understanding and functionality of its network systems. With utmost pressure on healthcare services and professionals, there is a large demand on high systems availability. The pressure felt by these professionals is brought on by high volumes of patient activity in the emergency and operating rooms, which require healthcare professionals to enter and document charts, access patient vitals and information instantly. Using data from the healthcare industry, an investigation was conducted to differentiate costs in monthly operating and installing fast optical Ethernet circuits, and decrease the percent of network utilization.

With the advancement in modern technology, advancements in network monitoring devices enables doctors and hospital professionals to perform rounds and have access to patient information, vitals, and lab results via hand-held wireless devices. Proper network traffic analysis that leverages network flow allows for a true understanding of which applications, hosts, and conversations are consuming the most network resources.

High availability and scalability for large enterprises is critical to maintain proper network performance; therefore, quickly pinpointing network outages can help maintain general operability at a more optimum level. This will allow for a more reliable and stable resolution in long-term network operability, maintenance, and performance.

The healthcare industry is an information intensive industry that requires a high-level of security, while maintaining network flexibility. With patient life at stake or often patient life lying on the table on an operating table; being able to access patient information bed side quickly is critical. Clinical data needs to be fully accessible because it directly can affect patient care. Some of the data that needs to be fully accessible are patient information and patient clinical information such as vitals, labs, x-rays, and act. This data also needs to be "HIPAA (Health

Insurance Portability and Accountability Act) Compliant” to protect patient information.

Hospitals have financial data that also needs to be readily accessible. In order to improve the quality of care, every healthcare organization must first recognize and understand the importance of enterprise network backbone. The network design and architecture should be by design to promote high availability and fault tolerance full redundancy at all levels.

As federal law and compliance guidelines forces and mandates all healthcare organizations to be up and running with an electronic medical records system, more and more hospitals are converting to this new electronic system. This electronic medical records application system has high priority on the network bandwidth.

Two of the most demanding and rapidly changing industries lie in the field of Network Engineering best practices and the healthcare industry. Although the field of information technology and network engineering is constantly changing and developing, the “need” remains constant. As the industry continues to grow and change, so does the demand. Through examining the significance of information technology within the healthcare industry, this study will also expose the current lack of information available regarding the types of data that reside on the network circuit via real time network monitoring tools. Through careful examination of modern technology and its components, healthcare professionals can one day adapt to a more technologically educated healthcare industry. As a result of more education, industries may experience greater advancements in the medical field and improve the overall quality of patient care.

It is most certainly a fact that planned outages are unavoidable. In order to minimize the stress and panic of an organization it is best to inform everyone of any planned outage well in advanced. An example of what this email notification could look like:

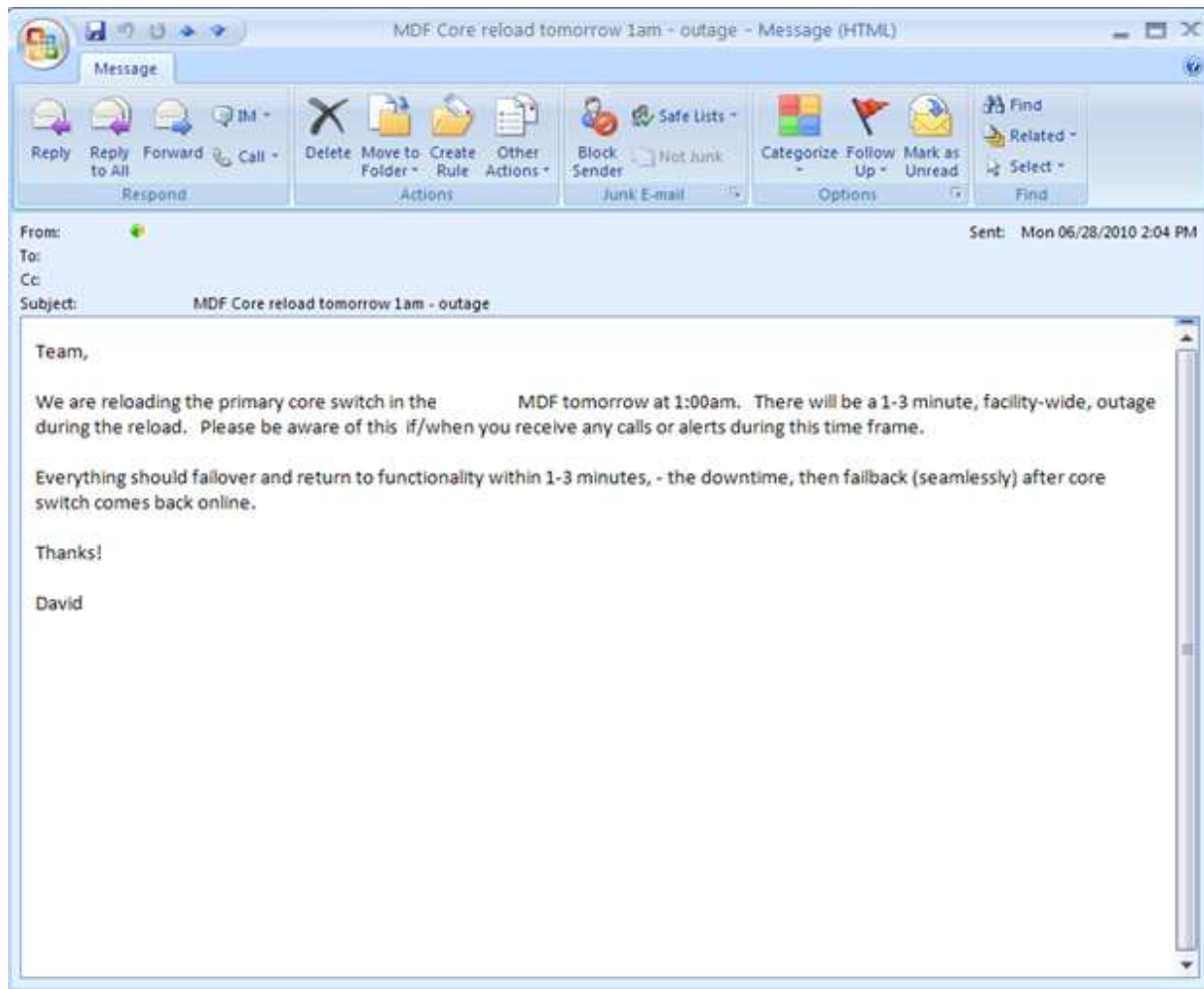

Fig 2 is an example of a planned down time network outage notification communicated to proper facility or various hospital departments.

Facilities	WAN Link Speed	Current Utilization	AT&T	TW	Qwest QMOE	HW Costs	Comments
Medical Center 1	6Mbps	75%	\$1,763	\$2,760		n/a	> 60% requires a circuit upgrade to maintain application performance. >80% users begin to complain of slowness.
Medical Center 2	10Mbps	85%	\$3,247	\$2,760		n/a	> 60% requires a circuit upgrade to maintain application performance. >80% users begin to complain of slowness.
Medical Center 3	6Mbps	85%	\$1,623	\$2,760		n/a	> 60% requires a circuit upgrade to maintain application performance. >80% users begin to complain of slowness.
Medical Center 4	6Mbps	85%	\$1,623	\$2,760	\$1,295	n/a	> 60% requires a circuit upgrade to maintain application performance. >80% users begin to complain of slowness.
Medical Center 5	1.5Mbps	50%	\$462	\$0	\$1,295	n/a	
Medical Center 6	1.5Mbps	55%	\$462	\$0	\$1,295	n/a	
Medical Center 7	6Mbps	75%	\$1,623	\$2,760		n/a	> 60% requires a circuit upgrade to maintain application performance. >80% users begin to complain of slowness.
Medical Center 8	1.5Mbps	50%	\$462	\$2,760		n/a	
Medical Center 9	3Mbps	80%	\$839	\$1,500		n/a	> 60% requires a circuit upgrade to maintain application performance. >80% users begin to complain of slowness.
Medical Center 10	*100Mbps	45%	\$7,500	\$8,850		n/a	* Currently 20Mbps converting to 100Mbps EavPN
Medical Center 11	3Mbps	50%	\$839	\$2,760		n/a	
TW CoLo	0	0%	\$0	\$2,760		n/a	
Total Monthly costs per vendor:			\$20,443	\$32,430	\$3,885		
<b>Total Monthly Market MAN/WAN costs 2009</b>			<b>\$56,758</b>				Network State of Union as of 7/5/09

Table 1 2009 sample monthly circuit costs (single MAN connection).

The outcome of this research will be evaluated by the cost savings and overall network stability and improvement. The logical approach in solving this problem will be resolved in the following three sequential phases.

**The Dual-MAN implementation is broken down in three logical phases:**

**Phase 1**

Order dual circuits from QMOE 100Mbps and Time Warner with 200Mbps and wait for activation from provider.

**Phase 2**

At the 2<sup>nd</sup> stage we should have and be carrying 3 circuits up and running at the same time

QMOE, Time Warner, and AT&T.

### **Phase 3**

Deactivate the AT&T circuit and test the new dual man for fail over.

The following diagram will show the comparison of the old network MAN and the newly improved network that will show the cost savings and optimized network management.

### **Failover Procedure**

#### **Failure Scenario #1:**

Inbound Internet circuit fails at any of the medical centers or at the Central Business Office

Internet Router fails at a Medical Center X facility

#### **Action to be taken:**

Verify the scenario

Shut down the Internet circuit to keep it from bouncing

Send email to notification to destitution list in outlook Team to alert the market

Instant failover will happen in less than 3 seconds and traffic will be re-routed to TW provider

Over the MAN and out to the RDC.

Troubleshoot the issue as needed: Either correct the hardware issue or contact Time Warner or

QMOE for the Internet circuit support

Verify traffic has normalized between facilities

#### **Failure Scenario 2:**

Core/LAN problems at specific Medical Center.

#### **Action to be taken:**



Verify the scenario

Shut down the MAN port on the facility with the issue main core switch, port#

Shut down the Internet circuit at this site

Send email to the Team to alert the market to use the secondary destination

Verify traffic has normalized between facilities.

Business Continuity Planning is critical to a facility to ensure that in the event of a significant unexpected business interruption, such as a natural disaster, the facility can effectively recover its business capabilities. The Business Continuity Plan should document all business functions and assets required to run the business, not just Information Systems processing resumption, which are referenced in the Disaster Recovery Planning Guideline. The arrangements for continuity should account for prolonged unavailability of: critical information resources, key personnel, telecommunications, office accommodations (or access to facilities), and managed services.

For the purposes of this research notification will be emailed out asking for a 30 minute time slot from all the medical center facilities to take down each circuit and move them over to the new much faster circuits. The actual switch should not take more than 10 minutes at the most.

### **Current Diagram**

By examining and detailing certain facets of information technology engineering in the field of healthcare and hospitals, this study will provide a thorough analysis of health information management and security. This can be achieved by analyzing the network traffic data that resides within the network, which will include, but is not limited to: patient data, scientific study data and results, and business departmental data. A survey of hospital networks

will allow a thorough understanding, breakdown, and interpretation of what type of data truly resides on a hospital network.

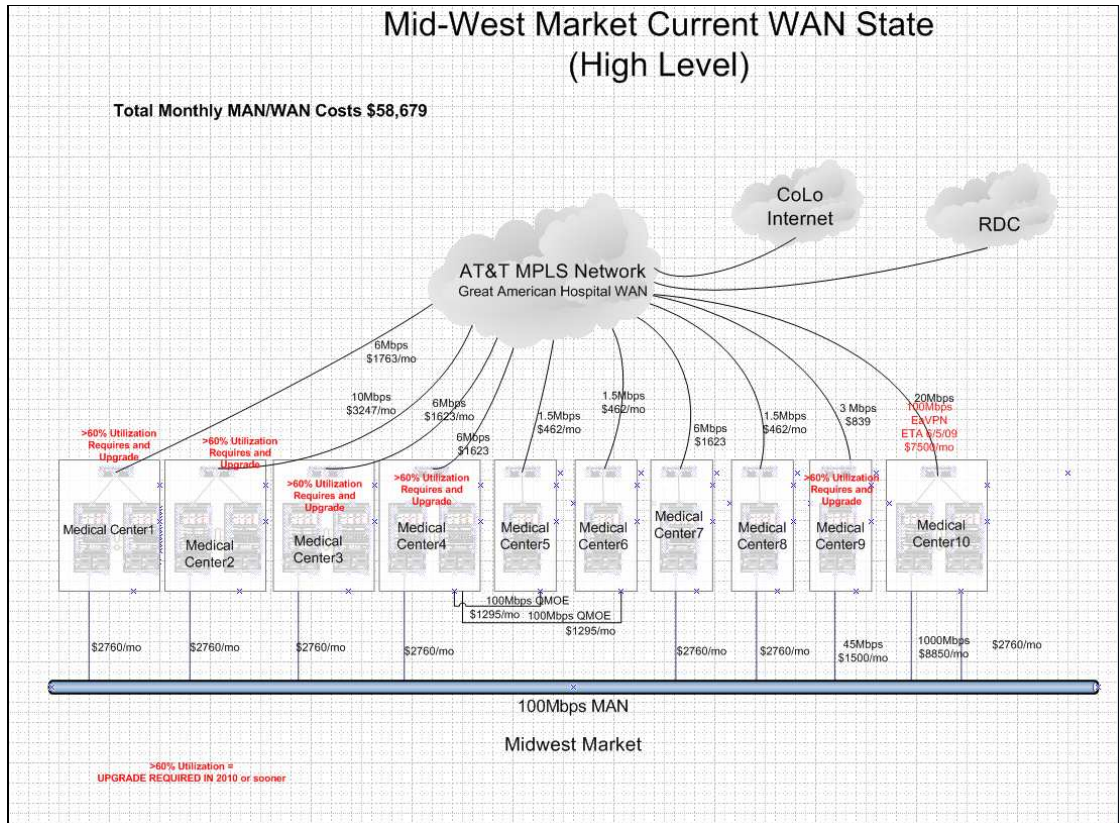

Figure 1

### 1.6 High Availability and Disaster Recovery

According to the Joint Commission Industry Standards and Compliance Hospital Regulation Committee, “The reason of the continuity of business plan is to identify the most critical information needs for patient care, treatment, services, business processes and the impact on the hospital if information systems were severely disrupted” (Keene & Auger, 2007).

Ways to make sure resources are available are backups, redundant array of inexpensive disks RAID and clustering. Some of other technologies that ensure high availability are fault

tolerance, network data mirroring and redundant network connections and equipment. Always backup configuration on routers and switches and other network devices make sure redundant mode power is set not "combined mode" for the power supply swap that way we have stateful failover. A stateful failover allows the network device such a switch or a router to maintain power while swapping out hardware devices. If one power supply fails the other one will remain fully functional and we can pull the bad hardware device out and replace it seamlessly. High network availability is designed in hardware; most Cisco, Juniper and HP switches and routers are designed with hardware redundancy. Hardware redundancy is necessary component to maintaining operations in times of hardware failure. This is even more true for instances such as hospitals and clinics. Switches come with hot swappable parts, such as dual power supplies for high availability. It is vital to have spare switches, power supplies, and other network devices and parts in case of hardware malfunction.

Avoiding unexpected outages and downtimes is one of the biggest challenges hospital information technology professionals face. All equipment should be fault tolerance from design to hardware equipment. Because just one of the hospitals in this network could easily have over 30 IDF's they should be designed in a way of primarily fault tolerance and they all are dual homed dual channeled. Voyence is the leading provider of configuration and change management solutions that automate critical change, compliance, configuration backups of Cisco network devices. Voyence also enables network professionals to monitor and track and record of who made changes in configuration of network devices with date and time stamp.

## **Chapter 2**

## **Network Infrastructure & Design: A Review of Literature & Research**

### **2.1 Past Research**

The research for this project will prove-out the hypothesis that Dual-MAN network architecture with redundancy and failover capabilities will improve the overall performance of a hospital's network while providing the availability and bandwidth required for communicating and exchanging large files. The hypothesis will be tested against by using the information gathered from previous research data and materials. Furthermore, information will be gathered and presented on past research completed on the hospital and healthcare industry and the integrated advancement of Information Technologies, which will help improve the quality of patient care and increase cost savings. According to a previous dissertation completed by Alex George, titled, *Analysis of a Highly Available Fault Tolerant Cluster Architecture* (2006), "Large technology driven health care organizations use network redundancy technology to provide fault tolerance and high availability on the network for systems to run mission critical applications." The dissertation provided relevant information toward the current architecture standings of clustered networks. George writes that "within a clustered network environment of an enterprise, high availability standards and failover capabilities must be met to improve network flow and maintain the standards required to keep business operations at an optimal level" (2006). This statement is true when relating a clustered environment to large hospital chains and healthcare facilities. Many enterprises and organizations become victims to problematic security breaches and hot spots. When dealing with clustered networks, these problems must be located and isolated quickly. Once found, additional resources must be leveraged in order to implement a solution to remedy the problem.

## 2.2 Theoretical Frameworks

The design should take into consideration continuous business productivity and minimize risk and plan for disasters of all kinds. According to the *Journal of World Health and Societal Politics*, “The continuity of business is vital in any setting and even more so in hospitals where the product is literally life and death” (Keene & Auger, 2007). The network upgrade coordinator has specific roles and responsibilities that apply to the upgrade project. Some of these include: producing timetables, planning, and test through Go-Live. Once the network is live on the new dual MAN, the daily operational network leader assumes responsibility for managing the live environment as documented. The network coordinator and his/her team will assemble and meet all milestones and deliverables for the network upgrade Go-Live date. The Network Upgrade Coordinator is responsible for all activities described to ensure a smooth and successful upgrade, Go-Live Day, and transition to the daily business operations.

## 2.3 What are the Questions to Be Answered?

- A) What are some problems and challenges Network Engineers face in large enterprise organizations?
- B) Can Ethernet MAN/WAN save money over point to point connections?

## 2.4 How Have Others Answered the Questions?

- A) Feamster, Winick, and Rexford, authors of “A Model of BGP Routing for Network Engineering” (2004) answer the aforementioned question by placing emphasis *on various network engineer problems and challenges*; some of these difficulties are ‘changes in traffic

load', 'changes in link capacity', 'planned maintenance', and 'failure and disaster planning'. The following is an excerpt from their article:

Because traffic is dynamic, the amount of traffic to any destination may suddenly change, causing changes in traffic distribution across network links a network operator must reconfigure routing policy to alleviate congestion. Network links are frequently upgraded to higher capacity. In response, network operators may wish to adjust configuration to route additional traffic through recently upgraded links. Network Operators commonly perform routine maintenance on portions of their network, adjusting interior routing link weights to divert traffic away from the part of the network that is undergoing maintenance. A network Operator may wish to evaluate the robustness of the network by examining the effects of failures on routing and traffic flow (p. 332-333).

B) According various connection service providers Ethernet MAN services are less expensive than private point-to-point connections. More and more organizations are utilizing fast Ethernet connection option as the primary connection for their enterprise.

## **Chapter 3**

### **Methodology: Research Instruments and Materials**

#### **3.1 Introduction**

The research and data was formulated by gathering data from local hospitals. The pricing information was sourced from various vendors such as Qwest, Time Warner, and Solarwinds.

For the simplicity of the network design comparison, the current network diagram and the new proposed network diagram with redundancy will be shown to illustrate the before and after transformation.

### 3.2 Design as an Artifact

A data center provides a centralized location to host main distribution frame and intermediate distribution frame points in network architecture. A data center supports server and network devices, such as routers and blade switches (Arregoces & Portolani, 2004). Data center goals and initiatives should include the following: “business continuance, increase security in the Data Center, application server and Data Center consolidation, integration of applications, and storage consolidations” (Arregoces & Portolani, 2004, p. 6). The specifications for the data center design are “availability, scalability, security, performance, and manageability” (Arregoces & Portolani, 2004, p. 6). The criticality of the data center's issues are “power capacity, cooling capacity, cabling, temperature and humidity controls, fire and smoke systems, physical security; restricted access and surveillance systems, rack space and raised floors” (Arregoces & Portolani, 2004, p. 7).

Data center architecture is composed of three main parts: scalability, flexibility and high availability.

- “Scalability – The data center must support fast and seamless growth without major disruptions” (Arregoces & Portolani, 2004, p. 117).
- “Flexibility – The data center must support new services without a major overhaul of its infrastructure” (Arregoces & Portolani, 2004, p. 117).
- “High-Availability – The data center must have no single point of failure and should offer predictable uptime and plan for hardware failures” (Arregoces & Portolani, 2004, p.117).

The New Dual MAN Hub architecture network design will be faster and more cost effective than the current network implementation. The research being proposed will involve designing and implementing a new network MAN diagram for a large hospital chain using a Visio diagram

and by contacting telecommunication circuit providers to conduct the research and provide the results for the cost benefit and savings. We are currently proposing and seeking approval of a dual-MAN network architecture design for each market facility. The upgrade will lower the total cost of ownership; this would increase bandwidth by a minimum of 10X for each site and still provide redundancy. The Qwest Metro Optical Ethernet (QMOE) is to be configured as the primary circuit. We need the 100mbps QMOE as the primary through Medical Center 10. The Time Warner 200mbps p2p (peer to peer) connection needs to be reconfigured on the MAN. Ultimately, the bundled T1 lines need to be shut down for all the parasite clinics and moved over on the new dual MAN connection.

The restructuring and improving of a network at this magnitude takes precise planning and execution. The duration of this project could ultimately take up to one year. The overarching plan is to redesign and restructure the network to make it become a dual MAN system. Large hospital chains have many parasites, clinic facilities that are not 24/7 operational and we can save cost by allocating enough bandwidth for them to be functional without fail-over. Only our main ten hospital facilities should be in full tolerance with instant 24/7 fail-over. What this means is that if a circuit connection is ever lost, or a provider goes down for unexpected reasons, no network downtime will be experienced, and network performance and quality of service will be preserved with the secondary provider.

Two of these ten facilities will be our "hub sites" where we have our MAN connections coming in from the providers. For the purpose of this study, Central Business Office and Medical Center 1 will be our hub sites. Time Warner and Qwest (Qwest Metro Optical Ethernet-QMOE) will be the new providers once we fully eliminate the costly bundled T1 lines from AT&T.



This plan will be methodologically implemented in three logical phases over a six-month to a year time span, in order to migrate and upgrade the proposed plan. A data center provides a centralized location to host main distribution frame and intermediate distribution frame points in network architecture. This plan should include high availability design, which “translates into a fully redundant architecture in which all possible hard failures are predictable and deterministic” (Arregoces & Portolani, 2004, p. 118). In addition, this would mean that “each possible component’s failure has a predetermined failover and fallback time, and that the worst case scenario for a failure condition is within the acceptable failover limits” (Arregoces & Portolani, 2004, p. 118).

The New Dual-MAN Hub architecture network design being will be faster and more cost effective than the current network implementation. The research was conducted by designing and implementing a new Dual-MAN network for the Mid-West Hospital by creating a Visio diagram to structure the new design. Additional, research steps were executed by contacting telecommunication circuit vendors to provide the results for the cost benefit and savings. The next step after data gathering would involve seeking approval of Dual-MAN network design architecture for this region. The upgrade will lower the total cost of ownership; this would increase bandwidth by minimum speeds of 10X for each site and still provide full redundancy. Qwest Communications, AT&T and Time Warner are the first established service providers to announce optical Ethernet services (Caisse, 2001). The Qwest Metro Optical Ethernet (QMOE) is to be configured as the primary circuit. We need the 100mbps QMOE as the primary through Medical Center 10. The Time Warner 200mbps p2p (peer-to-peer) connection needs to be reconfigured on the MAN.

### **3.2.1 Design Science Architecture**

#### **Metropolitan Area Network (MAN)**

A Metropolitan Area Network (MAN) is a large network that typically covers large areas such as towns or cities. A MAN usually interconnects various other networks using high-capacity technology such as fiber-optic links, and provides services to the WAN and the internet. The Mid-Western Hospital dual-MAN consists of ten medical centers, one supply chain warehouse, and the twenty clinics.

For the purposes of this research MANs will be examined for the network, which links multiple hospitals and healthcare facilities. The service providers, such as Qwest and Time Warner, lease high-speed connections and equipment to companies. As a result, additional costs are accumulated to the implementation and maintenance of a MAN network. Kim Caisse of *Network World Magazine* states, "Ethernet in the MAN offers bandwidth at attractive prices" (2001). Furthermore, Caisse add that, "Today's Ethernet is mature, fast and flexible enough to support data links to metropolitan and wide-area networks" (Caisse, 2001). For example, users at Medical Center 1, could use the high-speed data connection through the MAN network to easily access data from other branch centers such as Medical Center 10, with ease and security. It is also frequently used to provide a shared connection to other networks using a link to a WAN.

#### **The new dual-MAN**

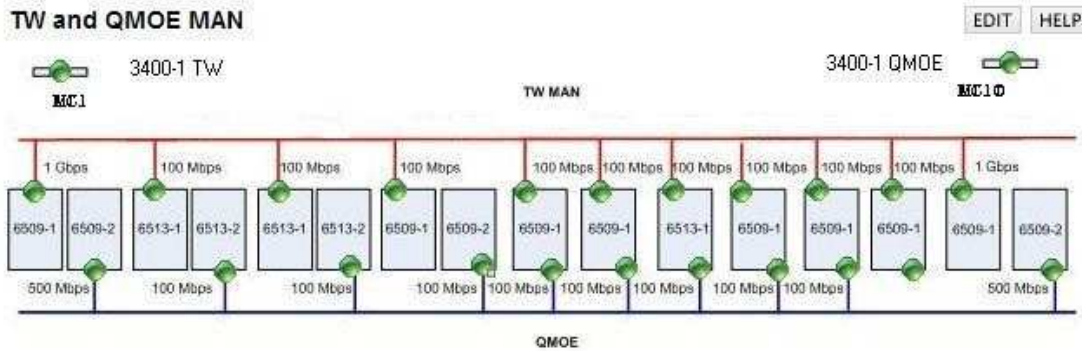

**Fig 5-2 Screen Shot of Solarwinds network market map**

The above map shows the new Dual-MAN for the Mid-Western Hospital market. Mid-Western Hospitals have multiple markets across the United States. Orion Solarwinds is a powerful network analyzer solution that allows for full visibility of the network.

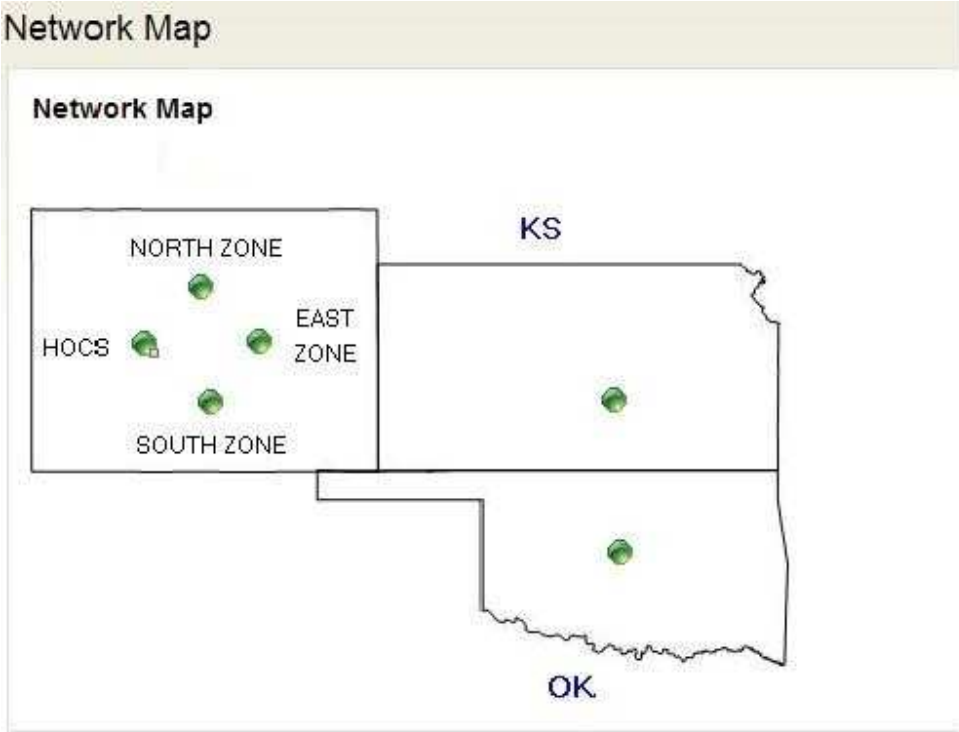

**Fig, 6 Division WAN diagram courtesy of Orion Solarwinds June of 2010\***

### Wide Area Network (WAN)

Unlike MAN, which just covers areas like cities within a state, a WAN spans across multiple states, as seen in Figure 6. WANs often connect multiple smaller networks, such as LANs or MANs.

The WAN is a secure and accessible network that provides interconnection between the facilities or medical centers in various states. The WAN is often used to improve the speed of the backup solution (Gibbs & Quillen, 2007, p. 54). According to Tim Greene of *Network World Magazine* (2010), “WAN optimization boosted application performance by reducing congestion” (p. 25), and network downtime.

### The New Dual WAN Network Diagram:

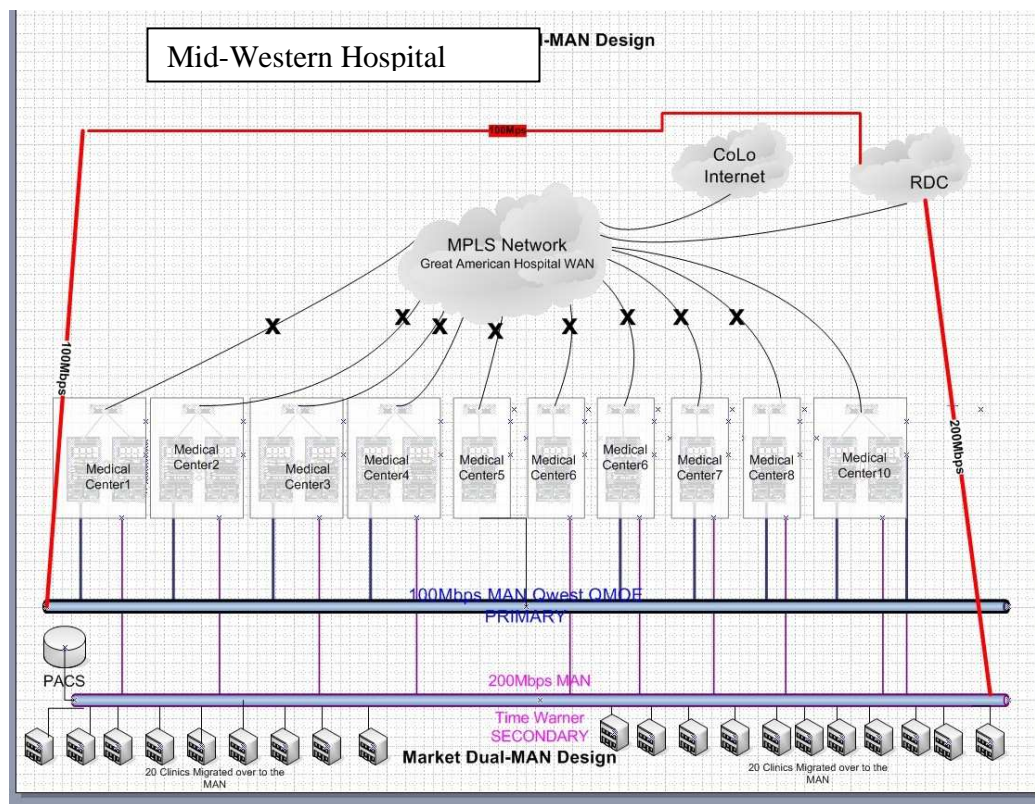

Fig. 4 New Dual-MAN network Diagram (full 24/7 redundant connection)

- AT&T circuits go away at all facilities
- TW MAN will be added as the backup connection and PACS traffic
- Qwest QMOE provides primary/backup with diverse path/provider to each facility.
- TW Connection is the 200Mbps secondary market connection
- All facilities benefit with higher LAN/MAN Speeds of 100Mbps or greater.

### **WAN Hospital Configurations**

Cisco equipment and configurations are used for the Mid-Western Hospital WAN configuration. Cisco routers use routing protocols such as Border Gateway Protocol (BGP) and Open Shortest Path First (OSPF). According to Gibbs & Quillen in, "The Medical-Grade Network: Helping Transform Healthcare (2007)", "The goal [of the WAN and the MAN] is to have reliable connectivity that can be updated easily while scaling to meet evolving business needs" (p. 8). In addition, the authors write that in order "to support healthcare's high-bandwidth, mission-critical applications across a WAN and MAN network" are needed (Gibbs & Quillen, 2007, p. 8). Frame Relay, ATM, and/or Leased-Line Services are some of the WAN connections that healthcare organizations choose from (Gibbs & Quillen, 2007, p. 8).

### **3.2.2 Structure & Guidelines**

Network architecture, is the logical and structural layout of the network consisting of transmission equipment, software and communication protocols and infrastructure (wired or wireless) transmission of data and connectivity between components (Keene & Auger, 2007). To create and design a working network we need to formulate a plan. Planning consists of making certain we are prepared for the network upgrade. Network diagrams models, hardware and

software requirements, protocols, rules and devices and physical specifications and limitations are taken into consideration. Application and software planning also plays a significant factor or role in network deployment. Sometimes maintaining and supporting legacy applications such as “Meditech” hampers network efficiency. Network design architectural diagram models are the foundation of the back bone of the network.

The network design “phase of a Data Center decides the physical medium to be used between network devices and servers, how to connect switches and routers, [and] how many LAN segments will be present” (Arregoces & Portolani, 2004, p. 479). The Mid-Western Hospital choice of physical medium is fast Ethernet, “with considerations of throughput and distances” (Arregoces & Portolani, 2004, p. 479). Currently, the majority of data centers “use either Fast Ethernet or Gigabit Ethernet as the LAN technology (Arregoces & Portolani, 2004, p. 479). Additionally, “the cost of Fast Ethernet and Gigabit Ethernet network interface cards is no longer a determining factor in which technology to deploy” (Arregoces & Portolani, 2004, p. 479).

### **3.3 Research Procedure**

There were numerous steps in the completion of this study. To begin, information gathering was essential to support the argument of this dissertation. This process included gathering data from literature, World Wide Web, and previous dissertations. The system design methodology approach was used to gather and assess technology solutions.

To demonstrate the new network diagram proposed in this thesis, Microsoft Visio was used to create detailed network diagrams. Personal work experience was extremely helpful and

beneficial in providing insight, industry terminology, and background in network engineering in this thesis study.

Specifically, articles in *Network World Magazine* and *Business Wire* support network management tools, such as NetQoS, Solarwinds, and WAN redundancy and optimization. Once the information was gathered, filtering the articles was important in deciding which articles were most relevant to this study and which could be omitted. All sources were printed and placed in different binders. Filtering was conducted by highlighting and note taking to finalize the research, which then was summarized, paraphrased, or directly quoted throughout this study to begin the writing process.

### **3.4 Research Participants**

To help with the deployment of the dual MAN circuit upgrade project, the following are key roles in research activity, implementation and deployment: Division Network Engineers, Division PACS Manager and PACS Systems Administrator. The System Administrator coordinates activities related to the PACS System with the Division PACS Project Manager, (the PACS application will have a 100Mbps of the 200Mbps MAN connection allocated and dedicated for improved accessing of PACS images with improved performance. The Organization's Information Systems Department and the local Radiology Department. Some of the responsibilities of maintaining a hospital PACS system are; Daily system monitoring, Storage media management; Network management; Quality control and performance monitoring; Security, including development and monitoring of policies and procedures.

The Network Upgrade Coordinator is responsible for communication and awareness:

- Appropriately sharing all upgrade-related communications to all members of the network and/or facility team any network or facility executives involved.
- Pushing down awareness through all levels of the organization.
- Promoting and ensuring communication throughout the upgrade process.
- Following the Network Upgrade Plan as a guide for key steps including communication items and timeframes
- Determining additional communication items, as necessary.

Level-setting expectations within the network/facility upgrade team.

Assemble a Network Upgrade Team based on your network's support structure. This team should include all appropriate facility specific personnel involved in the upgrade as well.

### **3.5 Research Location**

The research location was respectively dependent upon the research task. Local libraries and universities were accessed to conduct secondary research of scholarly journals and documents related to the research material. The primary research was conducted mostly in a central business office and at the IT department at a local company Denver. Further research and data collection was conducted at local hospitals and healthcare clinics.

### **3.6 Research Instruments and Materials**

The various tools used for this dissertation study are: library research, journals, magazines, previous dissertations, world wide web online, work experience, Microsoft Visio,



venders for pricing resources such as Insight, TW, Qwest, and network performance and monitoring software such as NetQoS Report Analyzer and the Orion Solarwinds.

### 3.6.1 Network Performance Monitoring Tools

These fast optical Ethernet data connections need rapid failure detection capabilities; hence, the need for network management and network monitoring software and hardware solutions is in demand (Caisse, 2001). As network switches and devices become more prevalent, there are various Network Management Monitoring tools that are available today (Caisse, 2001). For the purposes of this research, two very unique and powerful tools will be researched and examined. NetQoS and Orion SolarWinds are both network monitoring and reporting tools that provide real-time results of network systems. According to Keith Schultz of *InfoWorld*, a leading source of Information on emerging enterprise technologies, “Other forces are at work conspiring to rob your WAN’s performance and response time; latency, congestion, chatty applications, and traffic contention and the size of the pipe” (Schultz, 2005, p. 39). Furthermore, he went on to say, “congestion also affects WAN performance; congestion occurs when no bandwidth-allocation policy has been applied to traffic on the WAN, Network latency could be a significant problem on the MAN/WAN it can kill the network performance, both in response time and overall throughput on the MAN/WAN” (Schultz, 2005, p. 40).

The *Simple Network Management Protocol* (SNMP) “is used to retrieve information from network devices and hosts (manage devices) about their configuration, state, and counters for hardware and software components and to set the value of those components for configuration purposes” (Arregoces & Portolani, 2004, p. 697). SNMP provides management information services from network devices to the application server. The SNMP Management

Station locates and fixes network issues, proactively improves network performance, and prepares for network development and growth.

**Netflow** - When performance starts to deteriorate we can use netflow from solar winds to show us what and where on the network is the culprit. NetFlow shows the network traffic runs from a sql database and reports on Cisco equipment. Net flow gives us a metrics from SNMP. With NetFlow module in solar winds report analyzer we can sniff down to packets and IP address of switches or other network devices and dig deep to see packets and protocol bits that resized on the network. Netflow data is source and destination conversation that helps with troubleshooting that resides on the network and reports on the areas that are consuming the most bandwidth, and the least bandwidth. Netflow data will also provide network engineers with information regarding which applications are consuming the most bandwidth within their network and alert them when the circuit routing is down.

*\*Refer to the diagram below for an example of Netflow relating to Hospital Medical Center 1A\**

**Fig 10A shows NetQoS core Infrastructure**

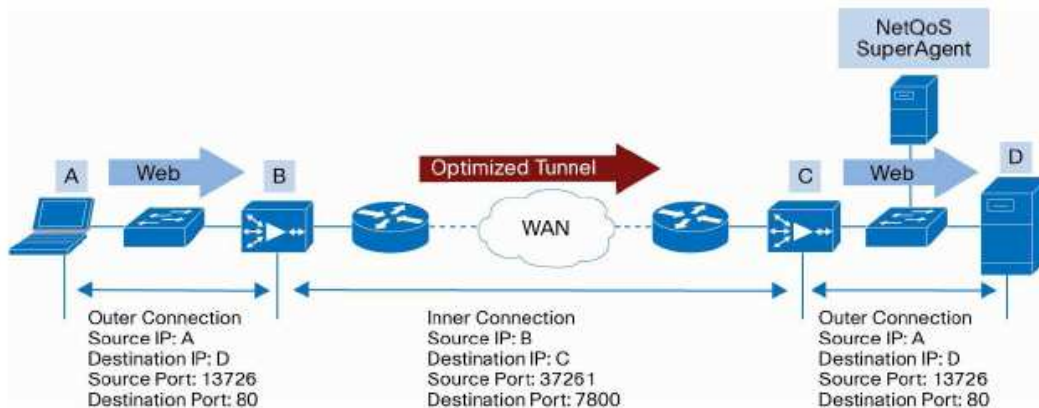

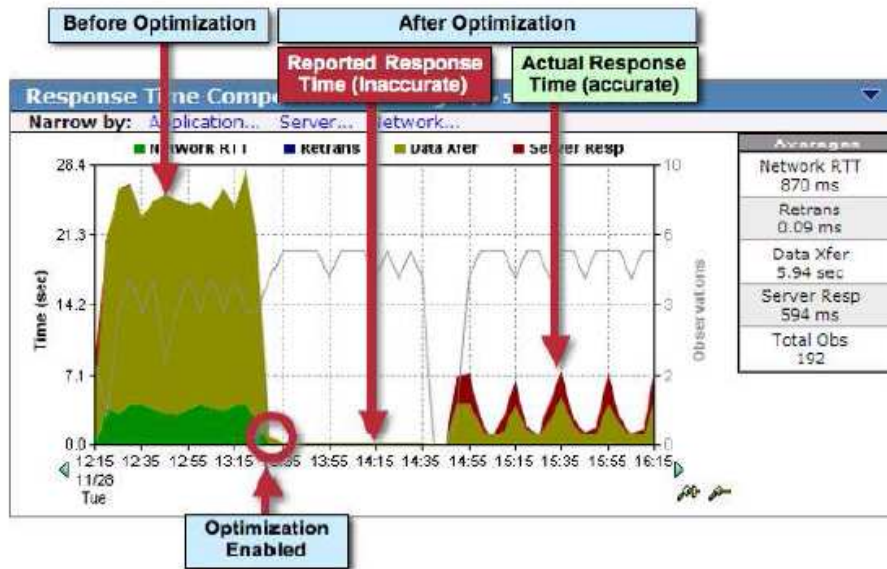

Figure 11A powerful tool within NetQoS Report Analyzer for network optimization

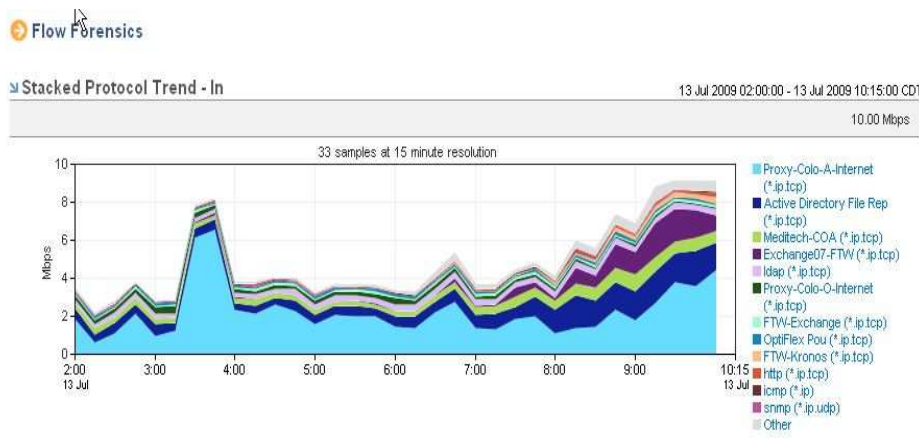
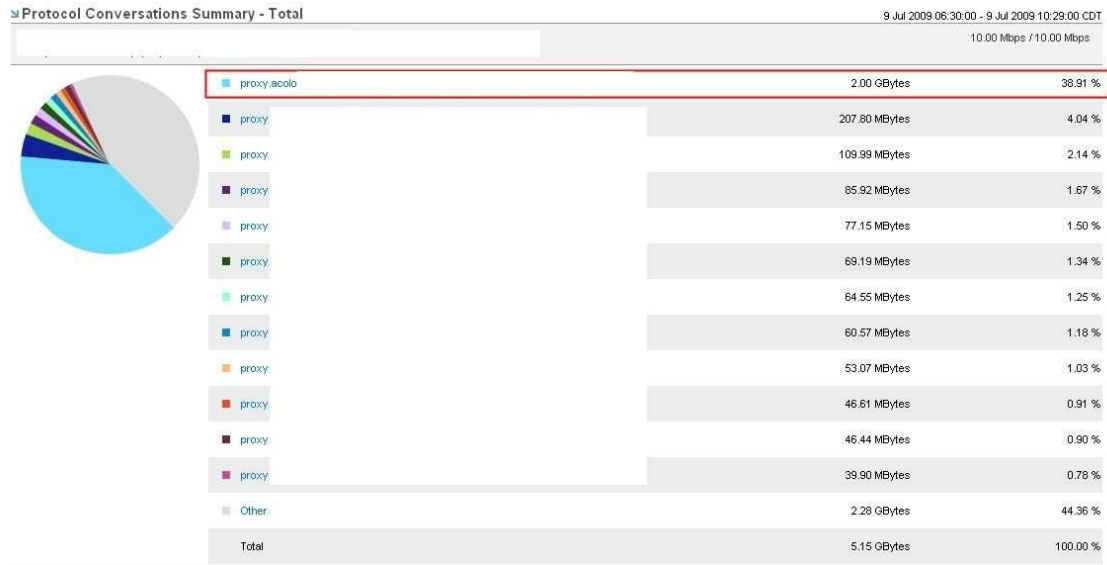
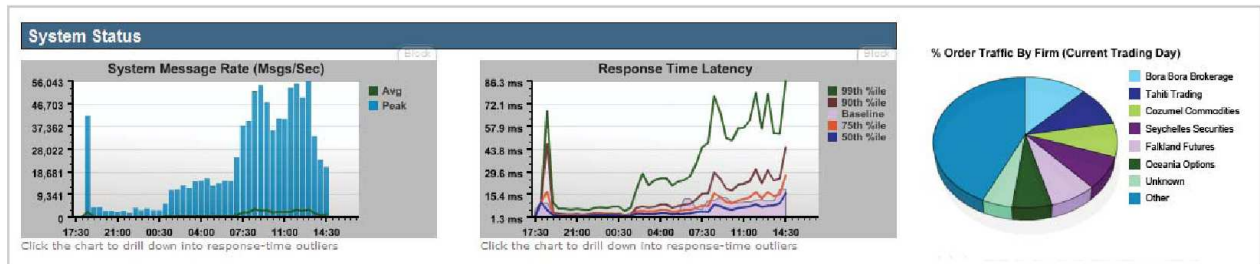

Figure 12 is an Example of Meditech (clinical mission critical application) flow forensics for Medical Center 5



**Fig 13 Protocol conversation Summary of various protocols on the Mid-Western Hospital network.**



The Trade Monitor dashboard highlights potential issues with at-a-glance views to help you quickly understand latency and trade volume across all sessions.

**Fig 14A - According to NetQos trade monitor datasheet NetQos can organize reports by orders messages with highest latency bubble to the top for easy investigation via drill downs to the message details. Top organizations in the world use this tool to monitor and manage and optimize application performance.**

### 3.6.2 Orion SolarWinds

According to Solarwinds.com (2010), the company was founded in 1998 and it provides powerful and affordable IT operations management software for network visibility and management. By continuing to grow and market to wide range of companies and housing a competitive array of network management tools, SolarWinds is to be looked at as an example of the future of network management (Solarwinds.com, 2010).

Some of the other useful products offered by solarwinds are the Orion network performance monitor, Orion network configuration manager, Orioin application performance monitor, Orion Netflow traffic analyzer, Orion IP address manager and VMware WMI monitors for the virtualization infrastructure (Solarwinds.com, 2010). Based on my cost analysis case study solarwinds is the smart, feasible, and customizable solution for any medium to large environments (Solarwinds.com, 2010).

SolarWinds is a network monitoring tool that is much more adaptable. We can customize and build in reports; it is easy to setup and user friendly. Cisco has their own suite of network management and monitoring tools that point the same data, but with solar winds it's more efficient and cost effective. Cisco uses a java based setup and pearl script for most of their software management tool that can sometimes be a nuisance.

According to *Spectrum Insight*, a company that sells hardware and software technologies, the SolarWinds Hardware and Software Price Quote, the total cost of the Orion SolarWinds ownership is \$110,000 (2010). The software cost is approximately \$42,939.49 (2010). Additionally, the cost of each server equals to about \$35,000 per server (2010). The cost of ownership SolarWinds (Acquisition, Implementation, Deployment) source for all price quotes is Insight Global and they are subject to change without notice. Mid-Western Hospital decided to

purchase software and hardware from *Spectrum Insight* because it is less expensive compared to purchasing directly from SolarWinds' manufacturer website.

**Solar Winds NetFlow Example Screen Shots:**

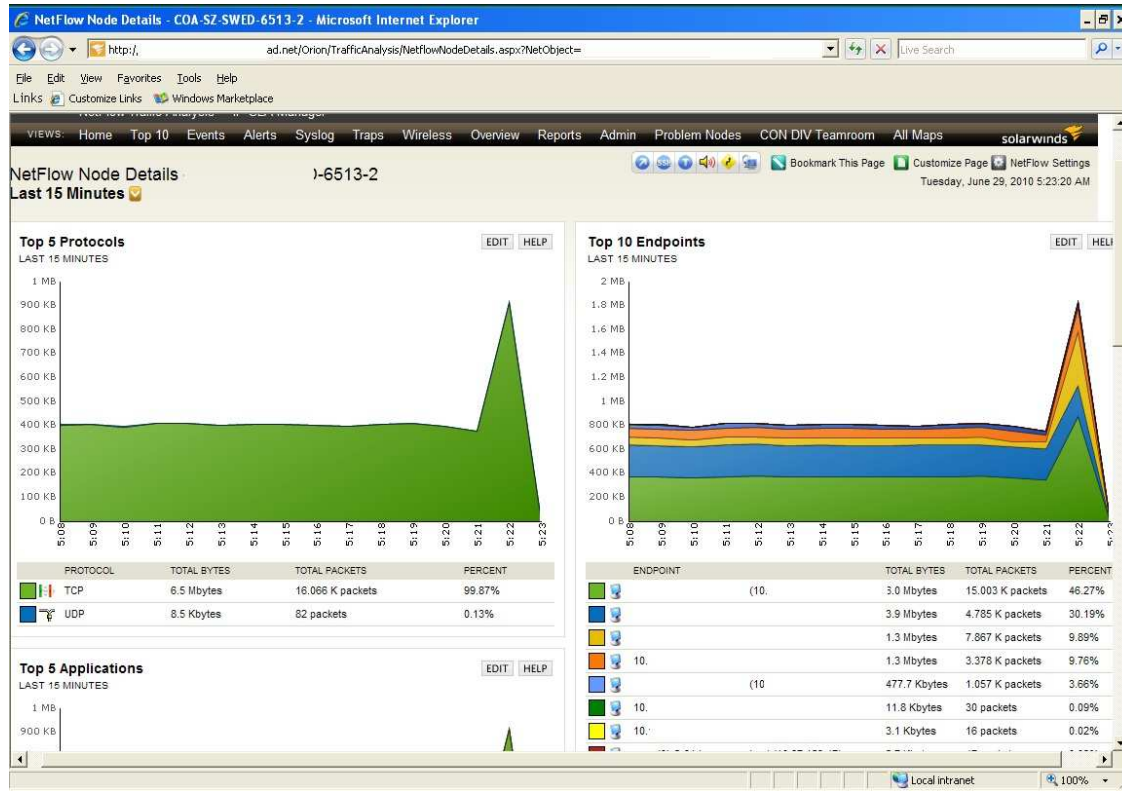

**Fig 7 Solarwinds Netflow Diagram (15 minute Increments)**

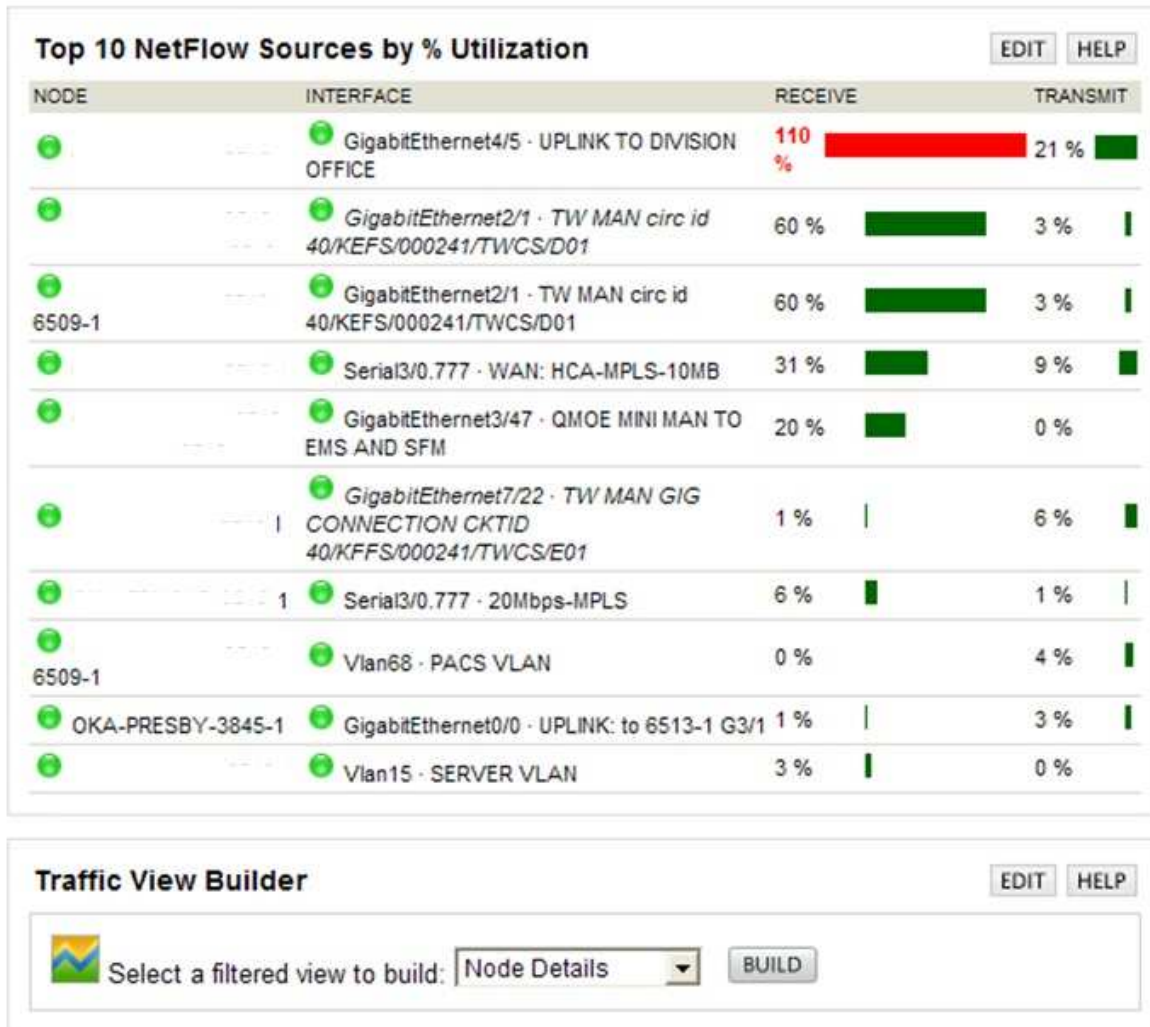

Fig 9A is an example diagram of a sample report from Orion SolarWinds shows percentage of network utilization. The diagram is changed to protect the company’s confidentiality. The data is presented in a clear and organized user interface which allows network monitors to read and interpret data quickly. The Orion SolarWinds tool shows reports of the network interface by percent utilization and volume and memory utilization. This power tool also alerts Network Engineers of Vlan mismatches discovered on the network, status changes and packet information received and transmitted and connection outages or data loss that might affect performance and enterprise functionality.

## Traffic viewer Solar winds:



**Fig 8A - from Orion Solarwinds diagram of the top 5 talkers on the network in almost live time. This example illustrates HTTP web traffic as the top throughput.**

SolarWinds allows users to run reports on top 5 applications and top 5 conversations or top talkers and view the bytes and packets send and received from router to any facility hub.

The following are excerpts from the article “Basic Wan Concepts” (2007) that define different connection types:

WANs are generally grouped into three separate connection types:

- Point-to-Point technologies



- Circuit-switched technologies
- Packet-switched technologies

Point-to-Point technologies (often called dedicated lines or leased lines) are usually the most expensive form of WAN technology. Point-to-Point technologies are *leased* from a service provider, and provide *guaranteed* bandwidth from location to another (hence point-to-point). Cost is determined by the distance of the connection, and the amount of *bandwidth* allocated. Generally, point-to-point links require no call-setup, and the connection is usually always on. Examples of point-to-point technologies include:

- T1 lines
- T3 lines

Circuit-Switched technologies require call-setup to occur before information can be transferred. The session is usually torn down once data transfer is complete (this is identified as an On-Demand Circuit). Circuit switched lines are generally low-speed compared to point-to-point lines. Packet-Switched technologies share a common infrastructure between all of the service provider's subscribers. Thus, bandwidth *is* not guaranteed, but is instead allocated on a best effort basis. Packet-switched technologies are ill suited for applications that require consistent bandwidth, but are considerably less expensive than dedicated point-to-point lines. (Balchunas, 2007, p.2).

The above excerpt describes the different choices in connection types that carriers offer or provide to companies.

This solution will be fully customizable and more adaptable than the current standards that have been implemented. SolarWinds is extremely user friendly when administered by properly educated IT professionals. To add a new device or switch, users login and click on an

admin tab, and then add a node - type in the desired switch IP or the new network device desired. Then simply name the device using a desired facility naming convention.

Fig, 15A. Automatic Email Notification Alerts from SolarWinds

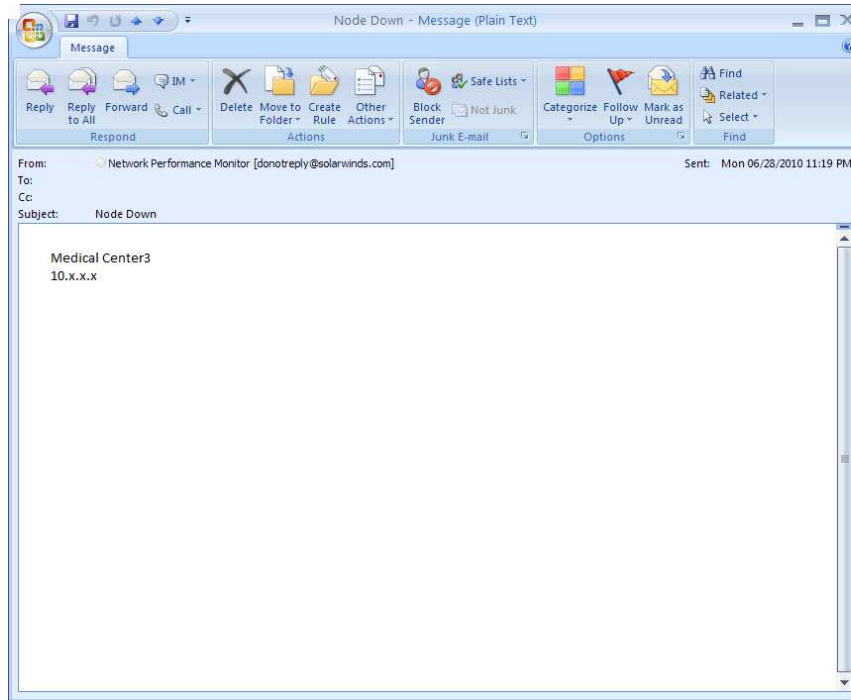

**Weather Goose** - monitors temperatures at IDF and MDF level, and reports on temperature, humidity and moisture levels. A flashing red light reports that the temperature is over 90 degrees and is reaching critical temperatures, or that a device is down.

A yellow flashing light is a warning sign indicating that one of the operating areas is experiencing a problem. A red light indicates that the system is down and has experienced a critical problem. The gray indicator indicates that the system is experiencing an unknown occurrence.

Network engineers could drill down by conversation and block ports that could exploit the network. Some of the common ports that viruses or network intruders can attack are 445 and 139.

One of the many customizable reporting tools that can be incorporated within SolarWinds is Weather Goose2 developed by the "IP Watch Dog" company. Weather Goose monitors IDF temperatures on network devices and UPS battery life devices. Because these devices are constantly running at high levels, the operating temperature correspondingly increases. As a result, higher temperatures will lower the life expectancy of the devices.

### 3.6.3 NetQoS

According to NetQos.com (2010), "*NetQoS* provides network performance management software and services that improve application delivery across the world's most complex networks." "Analyzing network traffic to determine which applications, servers, and clients are consuming network resources is a best-practice method for understanding root causes of application delivery issues" (NetQos.com, 2010).

"NetQos will ultimately improve the day-to-day business operations by providing network performance management products and services" (Redorbit.com, 2010). "Their unique product provides companies the ability to monitor application service levels as well as troubleshooting service" (Redorbit.com, 2010).

An example of a company that has benefited from NetQos is Community Medical Center (CMC). CMC consists of over 13 healthcare facilities and whose business model and success is predicated upon their ability in providing fast efficient access to patient files, as well as to assure health care providers that this information will be accessible 24x7x365 (Redorbit.com, 2010).

Not even cataclysmic events, such as a server crash, would impede this accessibility (Redorbit.com, 2010). “With this application network engineers can report on detailed application traffic patterns and their data enables them to justify bandwidth upgrades, reduce network costs by identifying under-utilized sites, troubleshoot issues faster and analyze the impact of new application rollouts to prioritize traffic appropriately” (Redorbit.com, 2007).

The following is an excerpt from an article published in *Business Wire* (2006), retrieved from Redorbit.com:

Community Medical Center's practice of implementing more than one circuit in order to ensure the patient files will at all times be accessible and backed-up has guaranteed a faster more efficient health care facility. The employees of this healthcare chain have noted that before implementing this practice by NetQos, they were not able to pinpoint the accuracy of their previous network system. With NetQos product makes reporting to hospital leadership easier on application service level quality on applications such as picture archiving and communications systems (PACS), radiology, lab, payroll, and hospital information system. NetQoS gives the network team an overall view of network performance, enabling them to better predict performance and troubleshoot problems fast. The NetQoS application is helping Community Hospitals another hospital chain like the Mid-Western Hospitals monitor PACS, one of the biggest applications and network intensive with no problems the network team an overall view of network performance, enabling them to better predict performance and troubleshoot problems faster. IT will enable network engineers provision the bandwidth more surgically which could save WAN costs by getting rid of unneeded bandwidth. According to Eric Rystad, a senior network communications engineer at Community Hospitals, NetQoS provided value they

were over 90 percent of the bandwidth on the WAN link, the network team was getting calls that the network was slow, but did not know the cause until they deployed this powerful tool, which enabled them to see and fix the problem. The performance improved instantly. (Redorbit.com, 2006).

An example of CMC's inability with their prior accessibility to patient files is evident by CMC's IT team having to spend hours of wasted effort that could have been better spent in other endeavors, such as troubleshooting (Redorbit.com, 2006). It is easy to see how this wasted effort could ultimately lead to CMC not being able to provide the proper care to the patients (Redorbit.com, 2006). As a result of implementing NetQos' products/services, the CMC facility was soon running faster and more time was spent attending to the patients in a timely matter (Redorbit.com, 2006.)

The NetQos Reporter Analyzer product enables you to see which applications are consuming large amounts of bandwidth, user recognition of the bandwidth use, and when the users are logged on to the network and consuming bandwidth (NetQos.com, 2010). The application flow lets you maximize performance on vital clinical healthcare applications such as Meditech and PACS. In NetQos Report Analyzer, the most important tool in network performance is the WAN and MAN management. Once you know which applications and users are consuming network resources, you can make timely and costeffective decisions to optimize network performance.

The overall cost of ownership with this hardware and software is approximately \$500,000 list price. This includes the report analyzer, reporting SNMP NetFlow, and IP round trip time test. Following support hardware, maintenance and support costs, and optional training costs are also necessary to be able to fully implement and deploy this product. You can push SNMP

Traps. Real time reporting on IDF power issues, monthly hospital power generator test can cause IDF power supply to flake out and setting a threshold on critical email notifications and alerts incase a device because unreachable. Gathering stats and monitoring and alerting proper staff members is vital when you deal with a large hospital of patient care.

### **3.7 Data Analysis**

The data gathered was analyzed based on circuit cost saving benefits and overall increased bandwidth and reduced network utilization on the new dual MAN for Mid-Western Hospital. Further data was gathered by comparing various network management tools and comparing them to NetQoS and Orion Solar Winds. The Orion SolarWinds and NetQoS Report Analyzer are the clear choice for ease of use and powerful reporting functionalities and capabilities. This data was then analyzed based on feasibility, live real time visibility and alerting, and customizability.

### **3.8 Hospital Network Security**

Patient confidentiality, high network availability, and data integrity, and employee security safety information and awareness are the main objectives for information security. Given these objectives, many IT professionals immediately begin to think of ways to safeguard the healthcare organization against possible threats. Information systems architecture should satisfy the defined business and security requirements. In addition, the architecture should provide capability, flexibility, performance, ease of use, and cost efficiency in the design. The security requirements for an information system should be carefully considered to define its architecture. Security should be built in to an information system by design. This strategy helps

lower the implementation costs and reduces the chances of risk due to the presence of loopholes in the system's security.

When designing the architecture of an information system, you need to balance the business and security requirements. Too much security can break functionality and day to day operation and business continuity. Trade-offs is involved in reaching a balance between security and business requirements.

The Network architecture of an information system should include a plan and designed to be fully redundant at all levels including hardware redundancy and a well documented disaster recovery plan. The ultimate goal is high availability and we can achieve this objective in the design infrastructure. Security policies and procedures are key element in safeguarding the organizations assets. It is up to every employee in the organizations to read and understand the security policy and report any security breaches immediately.

### **3.9 Mission Critical Clinical Applications**

The two primary mission critical clinical applications are PACS and Meditech Health Information Management (HIM) system. Meditech has provided Mid-Western Hospital's core hospital information system and been the trusted partner for many years. As healthcare changes with reform, Mid-Western Hospital is faced with the challenge of migrating to a fully functional electronic health record. To keep up with the advancing technologies, the organization needs a more versatile, robust clinical application, such as the EMR system, that would support electronic health record system. Electronic health record system is a paperless electronic system that makes it possible to access patient information simply from any hospital or physician's office.

To meet the functional requirements necessary to realize our mid and longer term objectives for Mid-Western Hospital's Electronic Health Record (EHR), significant investment is required. Such a move is a strategic decision that must satisfy physicians and support clinical operations for many years; therefore, all alternatives must be considered and all necessary due diligence must be completed. Organization executives only get one chance to ensure that this is the right decision for the long term.

As is expected, our evaluation of EHR solutions is informed first by the ability to support the best possible patient outcomes and the greatest usability by physicians, nurses, and other clinicians. To ensure Mid-Western Hospital's success, it is also informed by the ability to support the new business realities of contemporary healthcare in assuring the information resources to deliver the best patient care possible.

PACS System is the Picture Archiving and Communication System used by hospitals. This system is vital since doctors would require seeing patient information or images. These images are large and require more bandwidth allocation because they have to be readily available across the WAN at all of the hospitals and this data has to travel across the WAN to the RDC regional data center. To maintain application performance and network functionality I propose to set 60% of the 100Mbs just for this system to improve and sustain quality of service QS. The magnitude and the importance of accessing scientific and patient information instantly is vital and it can certainly effect patient care. The bandwidth allocated or reserved for accessing patient images is vital for surgeons and radiologist to provide and uphold a level of patient care that can potentially save lives. The PACS server is load balanced for optimization and higher accessibility. Mid-Western Hospital's Information Technology Services is rolling out the Picture Archive Communication System (PACS) in hospitals and outpatient centers using a market



approach. It is a three-year strategic initiative. PACS will digitally store and transmit a patient's medical images to any facility in the market connected to the system.

Meditech or Magic is the primary health care information system used by Mid-Western Hospital and various other prestigious hospitals across America. Meditech is the primary electronic health medical records (EMR). The federal government mandates all healthcare agencies to use an electronic medical records system that is secure. Hospitals utilize this system for admissions, clinical information such as labs and vitals, patient information face sheet to insurance information. Meditech gets automatic top priority and will automatically get bumped up.

All the aforementioned clinical application systems must have a 24/7 up-time and application priority on the network because it can directly affect patient care. Hospital network support engineers must use tools, such as Solarwinds and NetQoS, in conjunction to help scale down the large network and make it more feasible to manage.

## **Chapter 4 - Results & Objective Evaluation**

### **4.1 Results & Discussion**

Getting approval was a very clear and easy decision for executives at Mid-Western Hospitals with regards to the implementation of a dual-MAN network design for each market facility. Through this analysis, we have discovered that the network dual man upgrade ultimately increased the overall bandwidth speeds by a minimum of ten times for each site accompanied with full redundancy capabilities.

After reviewing various technical solutions and tools, while comparing and contrasting various methods of implementation, a fairly successful conclusion has been formulated that

allows for a more cost effective and efficient network process and framework. The design to implementation was rapid and frictionless. In networking and telecommunication industry the term “T-1” is a data circuit leased connection that runs at 1.544Mbit/s. Typically T1’s are expensive; they usually run (1.5 Mbps) at \$1200. The new bandwidth for our restructured MAN is ten times faster. The cost savings added up to approximately \$200 per month excluding maintenance and support costs.

Through research and analysis of the numbers figures and statistics provided the graphs and diagrams related to the Mid-Western Hospital network, a conclusion can be made that the new infrastructure and developed network process has ultimately saved money and improved overall performance.

Facilities	WAN Link Speed	Current Utilization	AT&T	TW	Qwest QMOE	HW Costs	Comments
Medical Center 1	6Mbps	75%	\$1,763	\$2,760		n/a	> 60% requires a circuit upgrade to maintain application performance. >80% users begin to complain of slowness
Medical Center 2	10Mbps	85%	\$3,247	\$2,760		n/a	> 60% requires a circuit upgrade to maintain application performance. >80% users begin to complain of slowness
Medical Center 3	6Mbps	85%	\$1,623	\$2,760		n/a	> 60% requires a circuit upgrade to maintain application performance. >80% users begin to complain of slowness
Medical Center 4	6Mbps	85%	\$1,623	\$2,760	\$1,295	n/a	> 60% requires a circuit upgrade to maintain application performance. >80% users begin to complain of slowness
Medical Center 5	1.5Mbps	50%	\$462	\$0	\$1,295	n/a	
Medical Center 6	1.5Mbps	55%	\$462	\$0	\$1,295	n/a	
Medical Center 7	6Mbps	75%	\$1,623	\$2,760		n/a	> 60% requires a circuit upgrade to maintain application performance. >80% users begin to complain of slowness
Medical Center 8	1.5Mbps	50%	\$462	\$2,760		n/a	
Medical Center 9	3Mbps	80%	\$839	\$1,500		n/a	> 60% requires a circuit upgrade to maintain application performance. >80% users begin to complain of slowness
Medical Center 10	*100Mbps	45%	\$7,500	\$8,850		n/a	* Currently 20Mbps converting to 100Mbps EaVPN
Medical Center 11	3Mbps	50%	\$839	\$2,760		n/a	
TW CoLo	0	0%	\$0	\$2,760		n/a	
Total Monthly costs per vendor:			\$20,443	\$32,430	\$3,885		
Total Monthly Market MAN/WAN costs 2009			\$56,758				Network State of Union as of 7/5/09

**Table 1 Mid-Western Hospital 2009 Example monthly Circuit costs (85% network utilized)**

DUAL-MAN Estimated 2010 Monthly Circuit Costs							
Facilities			AT&T	TW	Qwest QMOE	HW Costs & QMOE install fees	Comments
Medical Center 1			\$0	\$2,760	\$1,295	\$600	each site realizes between a 10-20x speed increase
Medical Center 1	Market point to point 200Mbps		\$0	\$9,300	\$0	\$2,500	**new** 10-20x faster.
Medical Center 2			\$0	\$2,760	\$1,295	\$600	each site realizes between a 10-20x speed increase
Medical Center 3			\$0	\$2,760	\$1,295	\$600	each site realizes between a 10-20x speed increase
Medical Center 4			\$0	\$2,760	\$1,295	\$0	each site realizes between a 10-20x speed increase
Medical Center 5			\$0	\$2,760	\$1,295	\$0	each site realizes between a 10-20x speed increase
Medical Center 6			\$0	\$2,760	\$1,295	\$0	each site realizes between a 10-20x speed increase
Medical Center 7			\$0	\$2,760	\$1,295	\$600	each site realizes between a 10-20x speed increase
Medical Center 8			\$0	\$2,760	\$1,295	\$600	each site realizes between a 10-20x speed increase
Medical Center 9			\$0	\$1,500	\$1,295	\$600	each site realizes between a 10-20x speed increase
Medical Center 10			\$7,500	\$3,350	\$1,295	\$600	each site realizes between a 10-20x speed increase
Central Supply Chain			\$0	\$2,760	\$1,295	\$600	20x speed increase
TW CoLo			\$0	\$2,760	\$0	\$0	n/a
Total Monthly costs per vendor:			\$7,500	\$41,750	\$14,245		
Total Hardware costs and circuit install fees						\$7,300	
			\$63,495				This solution is CHEAPER, FASTER, GAH-corporate-approved, and highly recommended

Table 2 Sample Total Monthly Market MAN/WAN costs 2010 (New Solution)

Estimated 2010 Monthly Circuit Costs							Network State of Union as of 7/5/09
Facilities	WAN Link Speed after upgrading	Estimated Utilization	AT&T	TW	Qwest QMOE	HW Costs	Comments
Medical Center 1	10Mbps	50%	\$3,247	\$2,760		5000	60% requires a circuit upgrade to maintain application performance.
Medical Center 2	15Mbps	60%	\$3,950	\$2,760			60% requires a circuit upgrade to maintain application performance.
Medical Center 3	10Mbps	60%	\$3,247	\$2,760		5000	60% requires a circuit upgrade to maintain application performance.
Medical Center 4	10Mbps	60%	\$3,247	\$2,760	\$1,295	5000	60% requires a circuit upgrade to maintain application performance.
Medical Center 5	3Mbps	50%	\$839	\$0	\$1,295		
Medical Center 6	1.5Mbps	50%	\$462	\$0	\$1,295		
Medical Center 7	10Mbps	60%	\$3,247	\$2,760		5000	60% requires a circuit upgrade to maintain application performance.
Medical Center 8	1.5Mbps	55%	\$462	\$2,760			
Medical Center 9	6Mbps	55%	\$1,623	\$1,500			goes to 6Mbps
Medical Center 10	*100Mbps	40%	\$7,500	\$8,850			
Central Supply Chain	3Mbps	50%	\$839	\$2,760			
TW CoLo	0		\$0	\$2,760			
Total Monthly costs per vendor:			\$28,663	\$32,430	\$3,885		
Total Hardware costs						\$20,000	
			\$64,978				This is the same technology path we have been taking. Problems and bottlenecks still persist even after upgrading circuits. More upgrades are required.

Table 3 2010 Example MAN/WAN costs

## 4.2 Data Collection and Analysis

Cost savings analysis and network performance utilization helps the Mid-Western Hospital Engineers justify this project to the Hospital CIO Chief Information Officer. Capital Expenses: Add \$5,000 per facility and clinic where each circuit is to be upgraded.

Operational Expenses: Subtract \$200 per month for each facility and clinic.

These numbers do not account for additional costs for internal resources and man hours needed to constantly upgrade and maintain the circuits. The overall process is a very daunting and time consuming event to upgrade all of the necessary circuits. Additionally, there is a one-time connection fee per circuit, which costs approximately \$1000.

There are twenty clinics that were on dedicated T1 and T3 lines. Each T1 line per month was approximately \$1,295.00 per month multiplied by twenty facilities, totals to \$25,900 per month at 1.5Mbps per clinic. These clinics are typically open only from 8AM to 5PM and there was no redundancy and the network was fully utilized. The current configuration of the twenty clinics was slow and expensive total annual circuit costs of \$310,800.

### 4.2.1 Overview of Research Data

#### Current Network Speeds after the upgrade

- The new dual MAN is 200 Mbps Time Warner.
- Time Warner at Medical Center 1 and Medical Center 10 are 1 gig, and same sites Qwest 500 Mbps (hub sites).
- Every other facility 100 mbps Time Warner and Qwest
- 200 Mbps Time Warner and 100 Qwest to Ft. Worth, TX (Regional Data Center).
- \$5,000 x facilities consist of 10 medical center 20 clinics and 1 supply chain location.

- Every facility is now 100 mbps or faster speeds compared to 1.5Mbps.

#### **4.2.2 Analysis, Comparisons, and Results of Network Performance Monitoring Tools**

- In comparison SolarWinds Orion is more intuitive, easy to use and the best value network management solution.
- Matches and surpasses NetQos report analyzer capability
- Complete visibility and control across network sites (various hospitals on the MAN), physical and virtual systems (Virtualization management and reporting), applications as well as Windows Event and Syslog monitoring to make not only rapid decisions and troubleshooting.
- Fault, configuration, traffic analysis, performance, security and compliance management as part of a complete solution
- Proven in hundreds of thousands of medium to large enterprise business matrix, and service provider networks worldwide
- 5 times less in cost than NetQos (Source Insight)
- Clear cut and user friendly to use compared to complex competitor solutions such as Ciscoworks and NetQos
- Increased network availability and network device health more greens on the network

#### **4.3 Analysis and Comparison of Previous Investigations and Research Findings**

According to Angelo Coiro's research and abstract, she states, "Ethernet carrier-grade technologies can be used to guarantee the performance of current transport technologies on the MAN or WAN in terms of operations, administration and maintenance, quality of service,

monitoring, and test capabilities in support of service level agreements; in particular, the Ethernet could replace current transport techniques, simplifying network design and reducing both capital and operational expenditures” (Coiro, et al., 2009). Previous research supports moving to a fast Ethernet connection is cost beneficial for other organizations; also research supports substantial evidence that NetQoS and Orion Solarwinds are the leading companies for network monitoring and management for large organizations all over the world. Furthermore, other large hospital chain healthcare organizations use NetQoS Report analyzer to help pinpoint network performance issues.

#### **4.4 Unanswered Variables**

As technology advances and changes these question will always come to play:

- How fast can the WAN\MAN speeds be from service providers if ‘cost’ was not a factor?
- As new competing companies arise in the industry what other network management monitoring solutions are suitable for large health care organizations?

#### **4.5 Research Study Limitations & Recommendations**

Limitations of this case study are choosing circuit speeds and services that optimize the network while saving money in the process. Over time further network upgrades will have to be taken to increase MAN speeds to meet with the needs of the changes in day to day business. This case study was not limited because it actually saved a significant amount of money, making it feasible and a wise choice and decision for approval.

Further research or recommendations to improve performance would be to move the primary domain controllers that authenticate users from the Fort Worth, TX RDC to inside the

MAN. This will eliminate thousands of authentication traffic from the WAN circuits. This might not be an issue with smaller enterprises but with a company the size of Mid-Western Hospitals it can make a significant difference and free up network bandwidth resources on the network.

#### **4.6 Barriers and Unknown Variables of the Research**

There are few barriers to consider in this project. There are some planned network outages downtimes to plan ahead for. And the duration of this project can take up to 1 year to execute and implement. An unknown factor is the service level agreements from the two service providers.

All the prices quoted in this study are subject to change without notice. For the purposes of this dissertation research, we will assume understanding of key routing protocols such as BGP and OSPF are principle requirements that are understood. Other technologies such as Vlan's and other common network abbreviations are implicit.

### **Chapter 5 - Conclusion**

The concepts learned in this context is with the core network architecture and design processes; enterprises can accomplish full redundancy, minimized downtime, and possibly save patient lives and save money simultaneously by clustering connections over a dual MAN. By having a fully redundant connection and with strategic planning and long-term strategies, Mid-Western Hospitals is minimizing risk and they are ready for future expansions of future medical centers or clinics. Having a dual MAN hub allows deployment of advanced network technology without any down times; this is a phenomenal business benefit. Having a dual redundant physical

MAN in place, with the help of powerful real-time visibility products and solutions such as Orion SolarWinds and NetQoS Report Analyzer, prevents and minimizes network outages.

Further research project or recommendations to improve network latency and network performance would be to move the primary domain controllers that authenticate users from the Fort Worth, Texas Regional Data Center to inside the MAN. This will eliminate thousands of authentication traffic from the WAN circuits. This might not be an issue with smaller enterprises but with a company the size of Mid-Western Hospital, it can make a significant difference and free up network bandwidth resources on the network. The New Dual MAN Network design implemented is now faster and more cost-effective.

The healthcare organization achieved objectives by creating a new full network redundancy by adding another MAN and increasing the bandwidth speed to 200Mbps and reduced network utilization tremendously. Often times, when performing a massive network upgrade, it is a good practice to take into consideration alternative backup plans and the total costs associated with them to compare them to the primary plan. The planning phase is key to take into account every hidden planned and unplanned expense and make a strategic informed decision. If Mid-Western Hospital would upgrade each circuit, they would have to pay a \$1000 one-time circuit build/connection fees and charges for every circuit implemented within the network. Another capital expense to consider is the DS3 cards they cost about \$5,000 each, this would increase the capital expense but the long term savings would make up for this expense. The network upgrade is cost effective that lowers the total cost of network ownership.

Another problem we are currently facing with having slower T1 lines is that every time the system administrators would push out an SMS package to a facility, it will bring down the entire network to a screeching halt. SMS is the Microsoft Systems Management server that



pushes out software and takes a collection of the entire organization. The SMS packages pushed to the clinics are causing network congestion because every single byte or packet would be authenticated over the WAN (back and forth) on a 1.5Mbps pipe. Now after the network upgrade implementation network speeds improved from 1.5Mbps to 10Mbps allocation per each clinic; the clinics SMS packages or security updates and or software are pushed out during off hours of the night - usually midnight and business operations is not being effected any longer with improved bandwidth.

With rapid cutting edge technologies, industry network experts can bring ingenuity and cost saving benefits and deliver a higher quality patient care to healthcare.

### References

- Arregoces,Portolani, M.M. (2004). *Data center fundamentals*. Indianapolis,IN:  
Cisco Press.
- Balchunas, A. (2007). *Basic WAN Concepts. v1.15*.  
Retrieved From [http://www.routeralley.com/ra/docs/basics\\_wan.pdf](http://www.routeralley.com/ra/docs/basics_wan.pdf)
- Caisse, K. (2001, December 24). *Can Ethernet be your MAN?*  
*Network World*,
- Coiro, Angelo and others, (2009). *Network Evolution Toward a Carrier-Grade  
Ethernet Transport Network, Fiber & Integrated Optics, Taylor & Francis Ltd Vol. 28  
Issue 6, p393-411 19p*
- Feamster, N. and Winick, J. and Rexford, J., *A Model of BGP Routing for Network Engineering  
(New York: ACM, 2004), Network Engineering Problems 332-33.*
- George, A. (2006). *Analysis of highly available fault tolerant cluster architecture*.  
(Doctoral dissertation, Oakland University, Rochester, Michigan, 2006.)
- Gibbs,Quillen, and Gibbs Mike M.H. (2007). *The medical-grade network:helping transform  
healthcare*. Indianapolis,IN: Cisco Systems Inc.
- Green, T. (2010, June 7). *WAN Optimization: Brings Broad Benefits*.

Network World, p.25.

Johnson, J.T., "Tips for designing a resilient WAN." Network World, (October 2003): 35.

Keene, S., & Auger, L., (2007, February). *Continuity of Business: Does your Hospital Have a Plan?*.

The Internet Journal of World health and Societal Politics, Volume 4 Number 2.

Retrieved from

<http://www.ispub.com/ostia/index.php?xmlFilePath=journals/ijwh/vol4n2/business.xml>

Schultz, K., "Building a Better WAN," InfoWorld (2005): 39-40

Retrieved from <http://www.silver-p>

[eak.com/assets/download/pdfpub/SilverPeak\\_ExecutiveGuide\\_InfoWorld\\_200611.pdf](http://www.silver-peak.com/assets/download/pdfpub/SilverPeak_ExecutiveGuide_InfoWorld_200611.pdf)

N/A. (2010, October 27). *About solarwinds*. Retrieved from

<http://solarwinds.com/NetPerfMon/SolarWinds/wwhimpl/js/html/wwhelp.htm#href=OrionAdministratorGuide.01.002.htm>

*NetQoS Performance Center Positioned to Become Primary Network Performance Management*

*Platform for IT Organizations* Business Wire. RedOrbit.com January 30 2007

Retrieved from [www.redorbit.com/news/technology/819856](http://www.redorbit.com/news/technology/819856)

N/A. (2006, September 28). *Netqos enhances network performances management for*

*community medical centers*. Retrieved from

<http://www.redorbit.com/modules/news/tools.php?tool=print&id=634454>

Business Wire. FindArticles.com. 10 Nov, 2010.

COPYRIGHT 2006 Business Wire

COPYRIGHT 2008 Gale, Cengage Learning