

Izaña Atmospheric Research Center



Activity Report 2012-2014

**Joint publication of State Meteorological Agency (AEMET)
and World Meteorological Organization (WMO)**

NIPO: 281-15-004-2

WMO/GAW Report No. 219



GOBIERNO
DE ESPAÑA

MINISTERIO
DE AGRICULTURA, ALIMENTACIÓN
Y MEDIO AMBIENTE



Cover photograph: Izaña Atmospheric Observatory (Photo: Rubén del Campo Hernández)

Citation:

Cuevas, E., Milford, C., Bustos, J. J., del Campo-Hernández, R., García, O. E., García, R. D., Gómez-Peláez, A. J., Ramos, R., Redondas, A., Reyes, E., Rodríguez, S., Romero-Campos, P. M., Schneider, M., Belmonte, J., Gil-Ojeda, M., Almansa, F., Alonso-Pérez, S., Barreto, A., González-Morales, Y., Guirado-Fuentes, C., López-Solano, C., Afonso, S., Bayo, C., Berjón, A., Bethencourt, J., Camino, C., Carreño, V., Castro, N. J., Cruz, A. M., Damas, M., De Ory-Ajamil, F., García, M. I., Fernández-de Mesa, C. M., González, Y., Hernández, C., Hernández, Y., Hernández, M. A., Hernández-Cruz, B., Jover, M., Kühn, S. O., López-Fernández, R., López-Solano, J., Peris, A., Rodríguez-Franco, J. J., Sálamo, C., Sepúlveda, E. and Sierra, M.: Izaña Atmospheric Research Center Activity Report 2012-2014. (Eds. Cuevas, E., Milford, C. and Tarasova, O.), State Meteorological Agency (AEMET), Madrid, Spain and World Meteorological Organization, Geneva, Switzerland, NIPO: 281-15-004-2, WMO/GAW Report No. 219, 2015.

For more information, please contact:

Izaña Atmospheric Research Center
Headquarters: Calle La Marina, 20
Santa Cruz de Tenerife
Tenerife, 38071, Spain
Tel: +34 922 151 718
Fax: +34 922 574 475
E-mail: ciai@aemet.es
<http://izana.aemet.es>

State Meteorological Agency (AEMET)
Headquarters: Calle Leonardo Prieto Castro, 8
Ciudad Universitaria
28071, Madrid, Spain
www.aemet.es

World Meteorological Organization (WMO)
7bis, avenue de la Paix
P.O. Box 2300
CH-1211 Geneva 2, Switzerland
www.wmo.int

NIPO: 281-15-004-2
WMO/GAW Report No. 219

Disclaimer: The contents of this publication may be reused, citing the source and date.



Izaña Atmospheric Research Center

Activity Report 2012-2014

Prepared by:

E. Cuevas¹, C. Milford^{1,2}, J. J. Bustos¹, R. del Campo-Hernández¹, O. E. García¹, R. D. García^{1,3}, A. J. Gómez-Peláez¹, R. Ramos¹, A. Redondas¹, E. Reyes¹, S. Rodríguez¹, P. M. Romero-Campos¹, M. Schneider⁴, J. Belmonte⁵, M. Gil-Ojeda⁶, F. Almansa^{1,7}, S. Alonso-Pérez^{1,8}, A. Barreto^{1,7}, Y. González-Morales⁹, C. Guirado-Fuentes^{1,3}, C. López-Solano⁹, S. Afonso¹, C. Bayo¹, A. Berjón¹, J. Bethencourt¹, C. Camino¹, V. Carreño¹, N. J. Castro¹, A. M. Cruz¹, M. Damas¹, F. de Ory-Ajamil¹, M.I. García^{1,10}, C. M. Fernández de Mesa¹, Y. González¹, C. Hernández¹, Y. Hernández¹, M. A. Hernández¹, B. Hernández-Cruz¹⁰, M. Jover⁹, S. O. Kühl¹, R. López-Fernández¹, J. López-Solano¹, A. Peris¹⁰, J. J. Rodríguez-Franco¹, C. Sálamo¹, E. Sepúlveda¹ and M. Sierra¹

Editors:

Emilio Cuevas¹, Celia Milford^{1,2} and Oksana Tarasova¹¹

¹Izaña Atmospheric Research Center, State Meteorological Agency (AEMET), Tenerife, Spain

²Centre for Research in Sustainable Chemistry (CIQSO), University of Huelva, Huelva, Spain

³Atmospheric Optics Group, Valladolid University, Valladolid, Spain

⁴Institute for Meteorology and Climate Research, Karlsruhe Institute of Technology (KIT), Karlsruhe, Germany

⁵Universidad Autónoma de Barcelona (UAB), Barcelona, Spain

⁶National Institute for Aerospace Technology (INTA), Atmospheric Research and Instrumentation Branch, Torrejón de Ardoz, Madrid, Spain

⁷Cimel Electronique, Paris, France

⁸Institute of Environmental Assessment and Water Research (IDAEA), CSIC, Barcelona, Spain

⁹SIELTEC, La Laguna, Tenerife, Spain

¹⁰University of La Laguna (ULL), Tenerife, Spain

¹¹World Meteorological Organization, Geneva, Switzerland

June 2015

Joint publication of State Meteorological Agency (AEMET)
and World Meteorological Organization (WMO)

NIPO: 281-15-004-2

WMO/GAW Report No. 219



World
Meteorological
Organization
Weather · Climate · Water



GLOBAL
ATMOSPHERE
WATCH

Contents

Foreword.....	vii
1 Organization	1
2 Mission and Background	1
3 Facilities and Summary of Measurements	2
4 Greenhouse Gases and Carbon Cycle	17
5 Reactive Gases and Ozonesondes	22
6 Total Ozone Column and Ultraviolet Radiation	28
7 Fourier Transform Infrared Spectroscopy (FTIR)	35
8 In situ Aerosols	42
9 Column Aerosols	48
10 Radiation.....	55
11 Differential Optical Absorption Spectroscopy (DOAS)	60
12 Water Vapour	64
13 Meteorology.....	69
14 Aerobiology	76
15 Phenology	80
16 AERONET-Europe Calibration Service	83
17 Regional Brewer Calibration Center for Europe (RBCC-E).....	85
18 Calima Warning System	93
19 Sand and Dust Storm Centres	95
20 North Africa AERONET/PHOTONS network.....	99
21 GAW Ushuaia twinning programme	102
22 GAW Tamanrasset twinning programme	103
23 WMO CIMO Testbed for Aerosols and Water Vapour Remote Sensing Instruments	105
24 Technological Projects.....	107
25 Capacity Building Activities.....	116
26 Publications	120
27 PhD Theses	133
28 Science Communication	135
29 List of scientific projects	138
30 List of major national and international networks and programmes.....	141
31 Staff	143
32 List of Acronyms	145
33 Acknowledgements.....	149

Foreword

The World Meteorological Organization (WMO) coordinates international research through the Global Atmosphere Watch (GAW) Programme, the World Weather Research Programme (WWRP) and the co-sponsored World Climate Research Programme. The GAW programme focuses on the coordination and application of high quality global observations of atmospheric greenhouse gases, ozone, ultraviolet radiation, aerosols and selected reactive gases as well as other components. It supports international conventions on ozone depletion, climate and long-range transport of air pollution. Through high quality, long-term measurements, the GAW programme leads to improved understanding of the atmospheric composition and its changes. The World Weather Research Programme advances society's ability to cope with high impact weather through initiatives such as the WMO Sand and Dust Storm Warning Advisory and Assessment System in close collaboration with GAW.

The Izaña Atmospheric Research Center, which is part of the State Meteorological Agency of Spain (AEMET), is a site of excellence in atmospheric science. It manages four observatories in Tenerife including the high altitude Izaña Atmospheric Observatory. The Izaña Atmospheric Observatory was inaugurated in 1916 and since that date has carried out uninterrupted meteorological and climatological observations, contributing towards a unique 100-year record to be reached in 2016.

The Izaña Atmospheric Observatory has contributed to the GAW Programme since its establishment in 1989 and is one of the 30 GAW Global stations which constitute the back-bone of the programme. It performs high quality, long-term (multi-decadal) measurements of atmospheric greenhouse gases, surface and column ozone, ultraviolet and solar radiation, in situ and column aerosols and selected reactive gases. Its measurement programmes contribute to both tropospheric and stratospheric atmospheric composition monitoring and research. The environmental conditions and pristine skies at Izaña are optimal for calibration and validation activities of both ground based and space borne sensors, while its strategic geographic location allows for study of diverse effects of atmospheric transport.

In addition to the GAW Programme, the Izaña Atmospheric Research Center contributes to many international activities, including the Network for the Detection of Atmospheric Composition Change (NDACC), it is actively involved in the co-management of the WMO Sand and Dust Storm Warning Advisory and Assessment Regional Center for Northern Africa, Middle East and Europe and has recently been nominated a WMO Commission for Instruments and Methods of Observations (CIMO) Testbed for Aerosols and Water Vapour Remote Sensing Instruments. AEMET has also played an essential role through the Izaña Atmospheric Research Center in capacity building and training activities in North African and South American countries.

It is a pleasure for me to present this report summarizing the many activities at the Izaña Atmospheric Research Center to the broader community as it approaches its milestone centenary celebrations in 2016. The combination of operational activities, research and development in state-of-the-art measurement techniques, calibration and validation and international cooperation encompass the vision of WMO to provide world leadership in expertise and international cooperation in weather, climate, hydrology and related environmental issues. I hope that it will inspire Members considering becoming involved in the GAW Programme and the other research programmes of WMO.



Dr Deon Terblanche

*Director of the Atmospheric Research and Environment (ARE) Branch, Research Department
World Meteorological Organization*





1 Organization

The Izaña Atmospheric Research Center (IARC) is part of the Department of Planning, Strategy and Business Development of the State Meteorological Agency of Spain (AEMET). AEMET is an Agency of the [Spanish Ministry of Agriculture, Food and Environment](#).

2 Mission and Background

The Izaña Atmospheric Research Center conducts monitoring and research related to atmospheric constituents that are capable of forcing change in the climate of the Earth (greenhouse gases and aerosols), and may cause depletion of the global ozone layer, and play key roles in air quality from local to global scales. The IARC is an Associated Unit of the Spanish National Research Council (CSIC), through the Institute of Environmental Assessment and Water Research (IDAEA). The main goal of the Associated Unit “Group for Atmospheric Pollution Studies” is to perform atmospheric air quality research in both rural and urban environments.

The IARC contributes to the World Meteorological Organization (WMO) Global Atmosphere Watch (GAW) programme, which was established in 1989 and has integrated a number of WMO research and monitoring activities in the field of atmospheric environment. The main objective of GAW is to provide data and other information on the chemical composition and related physical characteristics of the atmosphere and their trends, required to improve understanding of the behaviour of the atmosphere and its interactions with the oceans and the biosphere.

The Izaña Atmospheric Research Center also contributes to the Network for the Detection of Atmospheric Composition Change (NDACC), former Network for the Detection of Stratospheric Change (NDSC). The NDACC is a set of high-quality remote-sounding research stations for observing and understanding the physical and chemical state of the stratosphere. Ozone and key ozone-related chemical compounds and parameters are targeted for measurement. The NDACC is a major component of the international upper atmosphere research effort and has been endorsed by national and international scientific agencies, including the International Ozone Commission, the United Nations Environment Programme (UNEP), and the World Meteorological Organization.

Izaña Atmospheric Observatory was inaugurated in its present location on 1 January 1916, initiating uninterrupted meteorological and climatological observations which will constitute a 100-year record in 2016. Its early scientific studies focused on the study of high atmosphere through aerological observations, radiation, as well as on investigations with conventional meteorological parameters. In 1984, the governments of Germany and Spain signed an Agreement by which the observatory became a station of the WMO Background Atmospheric Pollution Monitoring Network (BAPMoN) under joint co-operation. In 1989, BAPMoN and GO3OS (Global Ozone Observing System) merged in the current Global Atmosphere Watch programme of which Izaña Atmospheric Observatory is one of the 30 GAW Global stations (Figure 2.1).



Figure 2.1. WMO GAW Global stations.

3 Facilities and Summary of Measurements

The Izaña Atmospheric Research Center (IARC) manages four observatories in Tenerife (Fig. 3.1, Table 3.1): 1) Izaña Atmospheric Observatory (IZO); 2) Santa Cruz Observatory (SCO); 3) Botanic Observatory (BTO); and 4) Teide Peak Observatory (TPO).

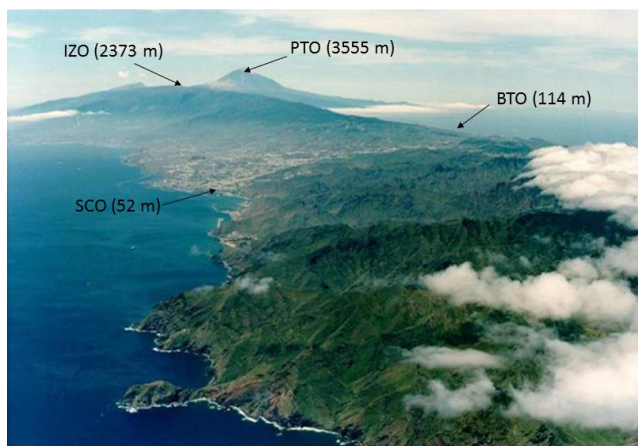

Figure 3.1. Location of IARC observatories.

Table 3.1. IARC observatories.

Observatory	Latitude	Longitude	Altitude (m a.s.l.)
IZO	28.309 °N	16.499 °W	2373
SCO	28.473 °N	16.247 °W	52
BTO	28.411 °N	16.535 °W	114
TPO	28.270 °N	16.639 °W	3555

3.1 Izaña Atmospheric Observatory

The Izaña Atmospheric Observatory (IZO) is located on the island of Tenerife, Spain, roughly 300 km west of the African coast. The observatory is situated on a mountain plateau, 15 km north-east of the volcano Teide (3718 m a.s.l.) (Figs 3.2 and 3.3). The local wind regime at the site is dominated by north-westerly winds. Clean air and clear sky conditions generally prevail throughout the year. IZO is normally above a temperature inversion layer, generally well established over the island, and below the descending branch of the Hadley cell.

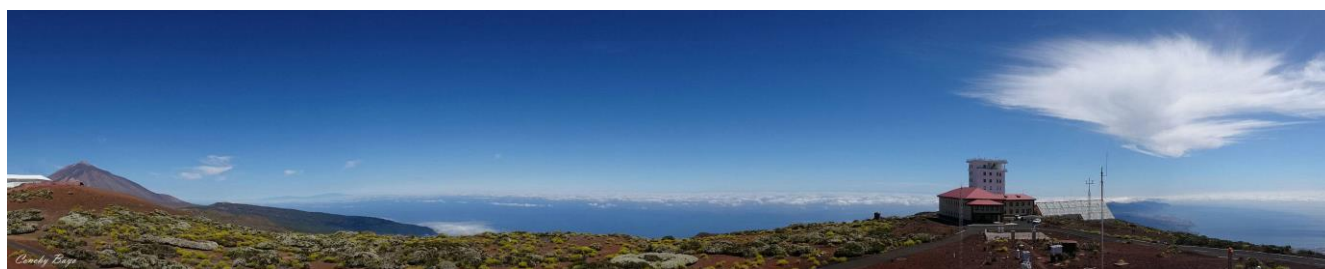

Figure 3.3 Izaña Atmospheric Observatory (2373 m) with the volcano Teide (3718 m) to the left of the image.



Figure 3.2. Image of Izaña Atmospheric Observatory.

Consequently, it offers excellent conditions for trace gas and aerosol in situ measurements under “free troposphere” conditions, and for atmospheric observations by remote sensing techniques. The environmental conditions and pristine skies are optimal for calibration and validation activities of both ground based and space borne sensors. Due to its geographic location it is particularly valuable for the investigation of dust transport from Africa to the North Atlantic, long-range transport of pollution from the Americas, and large-scale transport from the tropics to higher latitudes.

The Izaña Atmospheric Observatory facilities consist of three separate buildings: the main building, inaugurated in 1916; the aerosols lab (PARTILAB), a small nearby building of the same period; and the technical tower, completely rebuilt in early 2000, which hosts most of the instruments. Details of the IZO measurement programme are given in Table 3.2.

The main building is a two-storey building with a total area of 1420 m², which hosts the following facilities: office space, dining room, kitchen, library, conference hall with audio-visual system, meeting room, engine rooms, a mechanical workshop, and an electronics workshop. In addition, there is residential accommodation available for visiting scientists (seven double en-suite rooms).

The technical tower is a seven-storey building with a total area of 900 m². It includes 20 laboratories distributed among the different floors. All the laboratories are temperature-controlled. Details of the IZO Technical Tower facilities are given in Table 3.3.

Table 3.2. Izaña Atmospheric Observatory (IZO) measurement programme.

Parameter	Start date	Present Instrument	Frequency
Greenhouse Gases and Carbon Cycle			
CO ₂	Jun 1984	NDIR Licor 7000 (Primary instrument) NDIR Licor 6252 (Secondary instrument)	Continuous (30") Continuous (30")
CH ₄	Jul 1984	GC-FID Dani 3800 GC-FID Varian 3800	2 samples/hour 4 samples/hour
N ₂ O	Jun 2007	GC-ECD Varian 3800	4 samples/hour
SF ₆	Jun 2007	GC-ECD Varian 3800	4 samples/hour
CO	Jan 2008	GC-RGD Trace Analytical RGA-3	3 samples/hour
In situ Reactive Gases			
O ₃	Jan 1987	UV Photometry Teco 49-C (Primary instrument) Teco 49-C (Secondary instrument)	Continuous (1') Continuous (1')
CO	Nov 2004	Non-dispersive IR abs. Thermo 48C-TL	Continuous (1')
SO ₂	Jun 2006	UV fluorescence Thermo 43C-TL	Continuous (1')
NO-NO ₂ -NO _x	Jun 2006	Chemiluminescence Thermo 42C-TL	Continuous (1')
Total Ozone Column and UV			
Column O ₃	May 1991	Brewer Mark-III #157 (Primary Reference) Brewer Mark-III #183 (for developments) Brewer Mark-III #185 (Travelling Reference)	~100/day ~100/day ~100/day
Spectral UV: 290-365 nm	May 1991	Brewer Mark-III #157 (Primary Reference) Brewer Mark-III # 183 (for developments) Brewer Mark-III #185 (Travelling Reference)	~30' ~30' ~30'
Spectral UV: 290-450 nm	May 1998	Bentham DM 150	Campaigns
Column SO ₂	May 1991	Brewer Mark-III #157 (Primary Reference) Brewer Mark-III # 183 (for developments) Brewer Mark-III #185 (Travelling Reference)	~100/day ~100/day ~100/day
Column SO ₂	Oct 2011	Pandora#101	10'
Column HCNO	Oct 2011	Pandora#101	10'
Fourier Transform Infrared Spectroscopy (FTIR)			
Greenhouse gases, reactive gases, and O ₃ depleting substances (O ₃ , HF, HCN, HCl, ClONO ₂ , C ₂ H ₆ , HNO ₃ , CH ₄ , CO, CO ₂ , N ₂ O, NO, NO ₂ , H ₂ O, HDO, OCS)	Jan 1999 May 2007	Fourier Transform Infrared Spectroscopy Bruker IFS 120/5HR (co-managed with KIT) Middle infrared (MIR) solar absorption spectra Near infrared (NIR) solar absorption spectra	3 days/week (weather permitting)
Water vapour isotopologues (δD and δ18O)	Mar 2012	Picarro L2120-I δD and δ18O Analyser	Continuous (2")

Parameter	Start date	Present Instrument	Frequency
In situ aerosols			
Chemical composition of total particulate matter (PM _T)	Jul 1987	High-volume sampler custom built/MVC TM /MCZ TM Concentrations of soluble species by ion chromatography (Cl ⁻ , NO ₃ ⁻ and SO ₄ ⁼) and FIA colorimetry (NH ₄ ⁺), major elements (Al, Ca, K, Na, Mg and Fe) and trace elements by ICP-AES and ICP-MS were determined at the Research Council of Spain (CSIC) in Barcelona (http://www.idaea.csic.es/)	8h sampling at night
Chemical composition of particulate matter < 2.5 μm (PM _{2.5})	Apr 2002	High-volume sampler custom built/MVC TM /MCZ TM Concentrations determined at CSIC	8h sampling at night
Chemical composition of particulate matter < 10 μm (PM ₁₀)	Jan 2005	High-volume sampler custom built/MVC TM /MCZ TM Concentrations determined at CSIC	8h sampling at night
Number of particles > 3 nm	Nov 2006	TSI TM , UCPC 3025A	1'
Number of particles > 2.5 nm	Dec 2012	TSI TM , UCPC 3776	1'
Number of particles > 10 nm	Dec 2012	TSI TM , UCPC 3772	1'
Size distribution of 10-400 nm	Nov 2006	TSI TM , class 3080 + CPC 3010	5'
Size distribution of 0.7-20 μm	Nov 2006	TSI TM , APS 3321	10'
Absorption coeff. 1λ	Nov 2006	Thermo TM , MAAP 5012	1'
Attenuation 7λ	Jul 2012	Magee TM , Aethalometer AE31-HS	1'
Scattering coeff. 3λ	Jun 2000	TSI TM , Integration Nephelometer 3563	1'
Column aerosols			
AOD and Angstrom at 415, 499, 614, 670, 868, and 936 nm	Feb 1996	YES Multi Filter-7 Rotating Shadow-Band Radiometer (MFRSR)	1'
AOD and Angstrom at 340, 380, 440, 500, 675, 870, 936, 1020 nm	Mar 2003	CIMEL CE318 sun photometer	~ 15'
Fine/Coarse AOD Fine mode fraction	Mar 2003	CIMEL CE318 sun photometer	~ 15'
Optical properties	Mar 2003	CIMEL CE318 sun photometer	~ 1h
AOD and Angstrom during night period	July 2012	CIMEL CE318T sun photometer	~ 15' during moon phases
AOD and Angstrom at 368, 412, 500 and 862 nm	July 2001	WRC Precision Filter Radiometer (PFR)	1'
AOD at 769.9 nm	July 1976	MARK-I (at the IAC)	AOD at 769.9 nm
Radiation			
Global Rad. 285-2600nm	Jan 1977	2 CM-21 & CM-11 Kipp & Zonen Pyranom. (in parallel) and YES MFRSR	Continuous (1')
Estim. Direct Rad.	Feb 1996	YES MFRSR	Continuous (1')
Direct Rad. 200-4000nm	Aug 2005	2 CH-1 Kipp & Zonen Pyrheliometers	Continuous (1')
Direct Rad. 200-4000nm	Jun 2014	Absolute Cavity Pyrheliometer PMO6	Calibration campaigns (1')

Parameter	Start date	Present Instrument	Frequency
Radiation			
Diffuse Rad.	Feb 1996	YES MFRSR	Continuous (1')
Diffuse Rad. 285-2600nm	Aug 2005	2 CM-21 Kipp & Zonen Pyranometer (in parallel)	Continuous (1')
Downward Longwave Rad. 4.5-42 μ m	Mar 2009	2 CG-4 Kipp & Zonen Pyrgeometer (in parallel)	Continuous (1')
UVB Radiation 315-400nm	Aug 2005	2 Yankee YES UVB-1 Pyranometer (in parallel)	Continuous (1')
UVA Radiation 280-400nm	Mar 2009	Radiometers UVS-A-T	Continuous (1')
PAR 400-700nm	Aug 2005	Pyranometer K&Z PQS1	Continuous (1')
DOAS (managed by the Spanish National Institute for Aerospace Technology, INTA)			
Column NO ₂	May 1993	UV-VIS DOAS EVA and MAXDOAS RASAS II (INTA's homemade; www.inta.es)	Every ~3' during twilight
Column O ₃	Jan 2000	UV-VIS MAXDOAS RASAS II (INTA's homemade; www.inta.es)	Every ~3' during twilight
Column BrO	Jan 2002	UV-VIS MAXDOAS ARTIST-II (INTA's homemade; www.inta.es)	Every ~3' during twilight
Tropospheric O ₃	May 2010	UV-VIS MAXDOAS RASAS II (INTA's homemade; www.inta.es)	Every ~3' during twilight
Tropospheric NO ₂	May 2010	UV-VIS MAXDOAS RASAS II (INTA's homemade; www.inta.es)	Every ~3' during twilight
Tropospheric IO	May 2010	UV-VIS MAXDOAS RASAS II (INTA's homemade; www.inta.es)	Every ~3' during twilight
Column HCHO	Jan 2015	UV-VIS MAXDOAS ARTIST II (INTA's homemade; www.inta.es)	Every ~3' during twilight
Column Water Vapour			
Precipitable Water Vapour (PWV)	Feb 1996	YES MFRSR-7 Radiometer (941 nm)	1'
PWV	Jul 2008	GPS-GLONASS LEICA receiver	15' (ultra-rapid orbits) and 1h (precise orbits)
Vertical relative humidity	Dec 1963	Vaisala RS-92	Daily at 00 and 12 UTC
PWV	Mar 2003	CIMEL CE318 sun photometer	~ 15'
PWV	Jan 1999	Fourier Transform Infrared Spectroscopy	3 days/week when cloud-free conditions
Meteorology			
Temperature	Jan 1916	THIES CLIMA 1.1005.54.700 3 VAISALA HMP45C (in parallel) VAISALA PTU300 THIES CLIMA 1.0620.00.000 (thermo-hygrograph) CAMPBELL SCIENTIFIC CS215 (Tower top)	1' 1' 1' Continuous 1'

Parameter	Start date	Present Instrument	Frequency
Meteorology			
Relative humidity	Jan 1916	THIES CLIMA 1.1005.54.700 3 VAISALA HMP45C (in parallel) VAISALA PTU300 THIES CLIMA 1.0620.00.000 (thermo-hygrograph) CAMPBELL SCIENTIFIC CS215 (Tower top)	1' 1' 1' Continuous 1'
Wind direction and speed	Jan 1916	RM YOUNG Sonic 3D 81000 THIES CLIMA Sonic 2D THIES CLIMA Sonic 2D THIES CLIMA Sonic 2D (tower Top)	1' 1' 1' 1'
Pressure	Jan 1916	SETRA 470 VAISALA PTU 300 BELFORT 5/800AM/1 (Barograph) SETRA 470 (tower top)	1' 1' Continuous 1'
Rainfall	Jan 1916	THIES CLIMA Tipping Bucket THIES CLIMA Tipping Bucket Hellman rain gauge Hellman pluviograph	1' 1' Daily Continuous
Sunshine duration	Aug 1916	KIPP & ZONEN CSD3 Campbell Stokes Sunshine recorder	10' Continuous
Present weather and visibility	Jul 1941	THIES CLIMA drisdrometer BIRAL 10HVJS	10' 10'
Vertical profiles of T, RH, P, wind direction and speed, from sea level to ~30 km altitude	Dec 1963	RS92+GPS radiosondes launched at Güimar automatic radiosonde station (WMO GUAN station #60018) (managed by the Meteorological Centre of Santa Cruz de Tenerife)	Daily at 00 and 12 UTC
Soil surface temperature	Jan 1953	2 THIES CLIMA Pt100 (in parallel)	10'
Soil temperature (20 cm)	Jan 2003	2 THIES CLIMA Pt100 (in parallel)	10'
Soil temperature (40 cm)	Jan 2003	2 THIES CLIMA Pt100 (in parallel)	10'
Atmospheric electric field	Apr 2004	Electric Field Mill PREVISTORM-INGESCO	10"
Lightning discharges	Apr 2004	Boltek LD-350 Lightning Detector	1'
Cloud cover	Sep 2008	Sieltec Canarias S.L. SONA total sky camera	5'
Fog-rainfall	Nov 2009	THIES CLIMA Tipping Bucket with 20 cm ² mesh Hellman rain gauge with 20 cm ² mesh	1' Daily
Sea-cloud cover	Nov 2010	AXIS Camera: West View (Orotava Valley) AXIS Camera: South View (Meteo Garden) AXIS Camera: North View AXIS Camera: East View (Güimar Valley)	5' 5' 5' 5'
Drop size distribution and velocity of falling hydrometeors	May 2011	OTT Messtechnik OTT Parsivel	1'

Parameter	Start date	Present Instrument	Frequency
Aerobiology			
Pollens and spores	Jun 2006	Hirst, 7-day recorder VPPS 2000 spore trap (Lanzoni S.r.l.). Analysis performed with a Light microscope, 600 X at the Laboratori d'Anàlisis Palinològiques, Universitat Autònoma de Barcelona	Continuous (1 h resolution) from April to October
Phenology			
Emergence of the inflorescence, the appearance of flower buds, flowering, and fruit development according to the BBCH code of 7 taxa	Jan 2014	Visual inspection/counting	Weekly during growing season, and monthly the rest of the year

On the ground floor of the technical tower, there are two storage spaces, one of them for pressured cylinders (tested and certified at the Canary Islands Regional Council for Industry) and the other one for cylinder filling using oil-free air compressors. This floor also includes the central system for supplying high purity gases (H₂, N₂, Ar/CH₄) and synthetic air to the different laboratories. On the second floor, there is a dark-room with the necessary calibration set-ups for the IZO radiation instruments. On the top of the technical tower there is a 160 m² flat horizon-free terrace for the installation of outdoor scientific instruments that need sun or moon radiation (Fig. 3.4). It also has the East and West sample-inlets which supply the ambient air needed by in situ trace gas analysers set up in different laboratories.

The PARTILAB is a 40 m² building used as an on-site aerosol measurement laboratory. It has four sample-inlets connected to aerosol analysers. For more details, see Section 8. Outside Izaña Atmospheric Observatory there are the following facilities: 1) a 160 m² flat horizon-free platform with communications and UPS used for measurement field campaigns; 2) the meteorological garden, containing two fully-automatic meteorological stations (one of them the SYNOP station and the second one for meteorological research), manual meteorological gauges, a total sky camera, a GPS/GLONAS receiver, a lightning detector, and an electric field mill sensor; and 3) the Sky watch cabin hosting four cameras for cloud observations with corresponding servers.

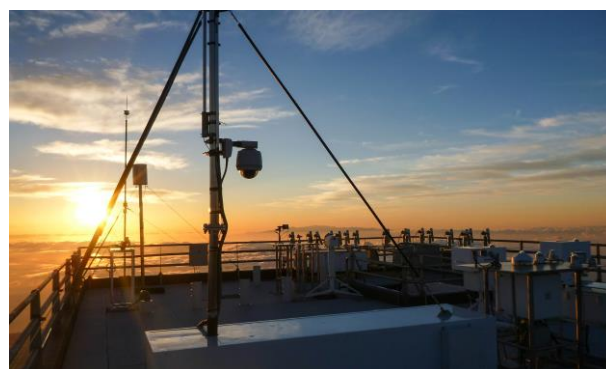

Figure 3.4. Images of IZO Instrument terrace.

Table 3.3. Izaña Atmospheric Observatory Technical Tower facilities.

Floor	Facilities	Description
Ground Floor	Mechanical Workshop	33 m ² room with the necessary tools to carry out first-step mechanical repairs.
	Electronics Workshop	25 m ² room equipped with oscilloscopes, power supplies, multimeters, soldering systems, etc. to carry out first-step electronic repairs.
	Heating system	Central heating and hot water 90 kW system.
	Air Conditioning System	Central air conditioning system for labs.
	Engine Room: Backup Generators	General electrical panel and two automatic start-up backup generators (400 kVA and 100 kVA, respectively).
	UPS room	Observatory's main UPS (40 kVA redundant) used for assuring the power of the equipment inside the building and an additional UPS (10 kVA) for the outside equipment.
	Compressor room	Room with clean oil-free air compressors used for calibration cylinders filling. It also contains the general pumps for the East and West sample inlets.
	Warehouse / Central Gas Supply System	30 m ² warehouse authorized for pressure cylinders. Central system for high purity gas (H ₂ , N ₂ , Ar/CH ₄) and synthetic air supply.
	Lift	6-floors. No lift access to roof terrace.
First Floor	Archive room	Archive of bands and historical records.
	Technical equipment warehouse	Spare parts for the Observatory's technical equipment.
	Meeting room	8 person meeting room
Second Floor	Optical Calibration Facility	30 m ² dark room hosting vertical and horizontal absolute irradiance, absolute radiance, angular response, and spectral response calibration set ups.
	T2.1 Laboratory	10 m ² lab with access to West sample inlet.
	T2.2 Laboratory	9 m ² lab with access to East sample inlet.
	T2.3 Laboratory	13 m ² lab hosting Picarro L2120-I δD and δ18O analyser with access to East sample inlet
Third Floor	Greenhouse Gases Laboratories	70 m ² shared in two labs hosting CO ₂ , CH ₄ , N ₂ O, SF ₆ and CO analysers with access to the East and West sample inlets.
Fourth Floor	All purpose laboratories	Three labs with access to the East and West sample inlets.
Fifth Floor	Reactive Gases Laboratory	10 m ² lab hosting NO-NO ₂ , CO, and SO ₂ analysers with access to West sample inlet.
	Communications room	Server room and WIFI connection with Santa Cruz de Tenerife headquarters.
	Brewer Laboratory	20 m ² lab for Brewer campaigns.
Sixth Floor	Surface Ozone Laboratory	10 m ² laboratory hosting surface O ₃ analysers with access to West sample inlet.
	Solar Photometry Laboratory	10 m ² maintenance workshop for solar photometers.
	Spectroradiometer Laboratory	25 m ² laboratory hosting two MAXDOAS and two spectroradiometers connected with optical fibre.
Roof	Instrument Terrace	160 m ² flat horizon-free terrace hosting outdoor instruments, East and West sample-inlets, wind, pressure, temperature and humidity gauges.

The following sections give further details of some of the facilities located at IZO.

3.1.1 Optical Calibration Facility

The optical calibration facility at IZO has been developed within the framework of the Specific Agreement of Collaboration between the University of Valladolid and the IARC-AEMET: “To establish methodologies and quality assurance systems for programs of photometry, radiometry, atmospheric ozone and aerosols within the atmospheric monitoring programme of the World Meteorological Organization”. The main objective of the optical calibration facility is to perform Quality Assurance & Quality Control (QA/QC) assessment of the solar radiation instruments involved in the ozone, aerosols, radiation, and water vapour programs of the IARC. The seven set-ups available are the following:

1) Set-up for the absolute irradiance calibration by calibrated standard lamps in a horizontally oriented position suitable for small radiometers (Fig. 3.5A). The basis of the absolute irradiance scale consists of a set of FEL-type 1000 W lamps traceable to the primary irradiance standard of the Physikalisch-Technische Bundesanstalt (PTB).

2) Set-up for the absolute irradiance calibration by calibrated standard lamps in a vertical oriented position suitable for relatively large spectrophotometers (Fig. 3.5B). The basis of the absolute irradiance scale consists of a set of DXW-type 1000 W lamps traceable to the primary irradiance standard of the PTB.

3) Set-up for the absolute radiance calibration by calibrated integrating sphere (Fig. 3.4C). The system is traceable to the AERONET standard at Goddard Space Flight Center (Washington, USA). This set-up is mainly used by Cimel sun-photometers, but other instruments are also calibrated.

4) Set-up for the angular response calibration (Fig. 3.5D). It is used to quantify the deviations of the radiometer’s angular response from an ideal cosine response. The relative angular response function is measured rotating the mechanical arm where the seasoned DXW-type 1000 W lamp is located. The rotation over $\pm 90^\circ$ is controlled by a stepper motor with a precision of 0.01° while the instrument is illuminated by the uniform and parallel light beam of the lamp.

5) Set-up for the spectral response calibration. It is used to quantify the spectral response of the radiometer. The light is scattered by an Optronics double monochromator OL 750 within the range 200 to 1100 nm with a precision of 0.1 nm. An OL 740-20 light source positioned in front of the entrance slit acts as radiation source and two lamps, UV (200-400nm) and Tungsten (250-2500nm) are available.

6) Set-up for the slit function determination (Fig. 3.5E). The characterization of the slit function is performed illuminating the entrance slit of the spectrophotometer with

the monochromatic light of a VM-TIM He-Cd laser. The nominal wavelength of the laser is 325 nm, its power is 6mW, and its beam diameter is 1.8 mm.

7) Set-up for the alignment of the Brewer spectrophotometer optics (Fig. 3.5F). It is suitable to perform adjustments of the optics without sending the instrument to the manufacturer.



Figure 3.5. Images of the IZO Optical calibration facility. A) Horizontal absolute irradiance calibration set up, B) Three stages of a Brewer irradiance calibration with the vertical set up, C) Absolute radiance calibration of a Cimel CE318, D) Angular response function determination of a Brewer (Photo: Alberto Redondas), E) Set up for Slit function determination and F) Alignment of a Brewer spectrophotometer optics (Photo: Alberto Redondas).

3.1.2 In situ system used to produce working standards containing natural air

GAW requires very high accuracy in the atmospheric greenhouse gas mole fraction measurements, and an updated direct link to the WMO primary standards maintained by the GAW GHG CCLs (Central Calibration Laboratories), most of which are located at NOAA-ESRL-GMD. To accomplish these requirements, IARC uses Laboratory Standards prepared (using natural air) and calibrated by NOAA-ESRL-GMD. Indeed, the Laboratory Standards used at IARC are WMO tertiary standards.

However, due to the fact that the consumption of standard and reference gases by the IARC GHG measurement systems is relatively high, an additional level of standard gases (working standards) prepared with natural air is used.

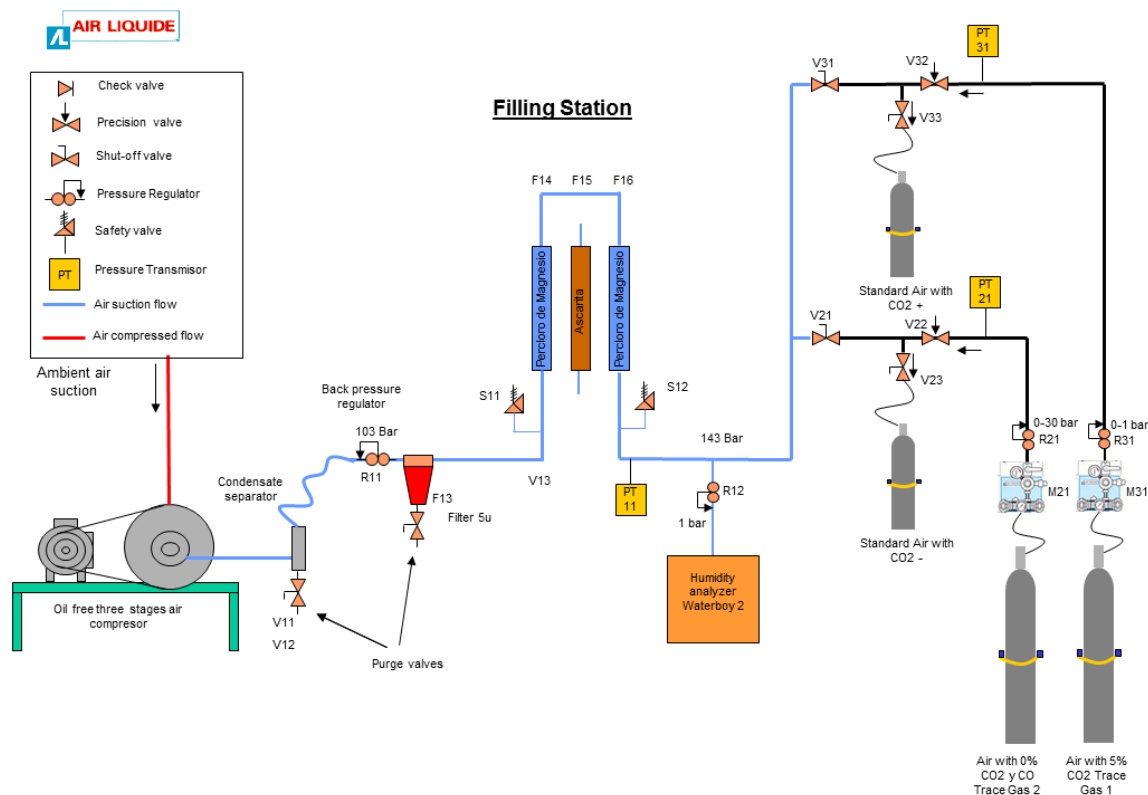

Figure 3.6. In situ system used to produce working standards containing natural air at Izaña Atmospheric Observatory.

These working standards are prepared at IZO using an in situ system (Fig. 3.6) and then calibrated against the Laboratory Standards using the IARC GHG measurement systems. The system used to fill the high pressure cylinders (till 120-130 bars) with dried natural air, takes clean ambient air from an inlet located on top of the IZO tower (30 metres above ground), and pumps (using an oil-free compressor) it inside the cylinders after drying it (achieving a H₂O mole fraction lower than 3 ppm).

Additionally, it is possible to modify slightly the CO₂ mole fraction of the natural air pumped inside the cylinders. To this end, air from a cylinder containing natural air with zero CO₂ mole fraction (prepared using the same system but adding a CO₂ absorber trap) or a tiny amount of gas from a spiking CO₂ cylinder (5% of CO₂ in N₂/O₂/Ar) is added to the cylinder being filled. This system is similar to that used by NOAA-ESRL-GMD to prepare WMO secondary and tertiary standards, and it is managed and operated at IZO through a subcontractor (Air Liquide Canarias). The prepared working standards are mainly used in the GHG measurement programme, but some of them are used for other purposes (natural air for a H₂O isotopologue CRDS analyser located at Teide peak and for a CO NDIR analyser located at SCO).

3.1.3 Central Gas Supply System

There is a gas central facility located on the IZO tower ground floor for supplying chromatographic gases to the

different instruments. This central facility supplies high purity: N₂ (used as carrier gas for the GC-FIDs, and for the IZO H₂O isotopologue CRDS analyser), synthetic air (used as oxidizer in the FIDs, as carrier gas in the GC-RGD, as carrier gas in the IZO H₂O isotopologue CRDS analyser, and as diluting air used in the calibrations of the reactive gas instruments), 95% Ar / 5% CH₄ (used as carrier gas for the GD-ECD), and H₂ (used as combustible in the FIDs). This facility and the chromatographic gases are managed and provided, respectively, by a subcontractor (Air Liquide Canarias). The H₂O isotopologue CRDS analyser located at Teide peak has its own dedicated high purity N₂ supply. The reactive gas analysers located at SCO have their own dedicated high purity synthetic air supply (used as diluting air in the calibrations).

Additionally, other gases (provided by the same subcontractor) are used at IZO: high purity CO₂ for the calibration of an aerosol nephelometer, high purity N₂O for FTIR instrumental line shape monitoring, liquid N₂ to cryocool the FTIR detectors, and calibrated concentrated gas standards in N₂ (19.4 ppm NO and 19.4 ppm NO_x, 1.01 ppm CO, 1.04 ppm CO, 99.9 ppm CO, 102 ppm SO₂, and 1 ppm SO₂) for the calibration of the instruments of the reactive gas programme.

3.2 Santa Cruz Observatory

The Santa Cruz de Tenerife Observatory (SCO) is located on the roof of the IARC headquarters at 52 m a.s.l. in the capital of the island (Santa Cruz de Tenerife), close by the city harbour (Figs. 3.7 and 3.8). Details of the SCO measurement programme are given in Table 3.4.



Figure 3.7. Image of Santa Cruz Observatory.

This observatory has two main objectives: 1) to provide information of background urban pollution for atmospheric research and interactions with long-range pollution transport driven by trade winds or Saharan dust outbreaks and 2) to perform complementary measurement programmes to those performed at IZO. The IARC headquarters include the following facilities:

- A laboratory for reactive gases (surface O_3 , NO - NO_2 , CO and SO_2).
- A laboratory for micro pulse Lidar (MPL) and ceilometer VL-51.
- A laboratory to dry and weigh filters of high and low volume aerosol samplers.
- A laboratory for the preparation of ozonesondes
- A 25 m² flat horizon-free terrace for radiation instruments and air intakes.



Figure 3.8. Instrument terrace of Santa Cruz Observatory.

3.2.1 Aerosol Filters Laboratory

The Aerosol Filters Laboratory is equipped with an auto-calibration microbalance (Mettler Toledo XS105DU) with a resolution of 0.01 mg, a set of standard weights, and an oven that reaches 300°C. Filters are weighed after temperature and humidity conditioning following the requirements of the EN-14907 standards. This filter weighing procedure is used for determining the concentrations of TSP, PM_{10} , $PM_{2.5}$ and PM_1 by means of standardized methods. Filters are conditioned to 20°C and a fixed relative humidity (50% RH for air quality studies and 30% RH for research studies) within a methacrylate chamber, which also contains the balance used for weighing the filters (Fig. 3.9).

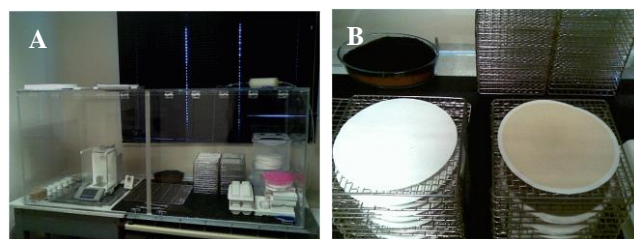

Figure 3.9. A) Aerosol Filters laboratory: temperature and relative humidity controlled chamber. B) Filters before and after sampling.

3.2.2 The Ozonesonde Laboratory

Advanced preparation of the Science Pump Corporation (SPC) ECC ozone sensor (Model ECC-6A), together with digital Vaisala RS92 radiosonde and digital interface, is performed at the Ozonesonde Lab at SCO. Expendables such as radiosondes, interfaces, ozonesondes, ozone solution chemicals, syringes, needles, protection gloves, and triple distilled water are stored in this lab.

A Science Pump Corporation Model TSC-1 Ozonizer/Test Unit is used for ozonesonde preparation. This unit has been designed for conditioning ECC ozonesondes with ozone, and for checking the performance of the sondes prior to balloon release. The Ozonizer/Test Unit is installed inside a hood in which ambient air is passed through an active charcoal filter to destroy ozone and other pollutants (ozone-free air). The volumetric flow of the gas sampling pump of each ECC sonde is individually measured at the Ozonesonde Lab before flight. The pump flow rate of the sonde is measured with a bubble flow meter at the gas outlet of the sensing cell.

On the day before release, two ECC-6A ozonesondes are checked for proper operation and filled with sensing solution. The day of the ozonesonde launching the sensors are transported to BTO ozonesonde launching station (30 km distance) where pre-launch tests are performed at ground including a final double check of the RS-92, and a comparison of surface ozone from ECC-A6 with a TECO-49C ozone analyser.

Table 3.4. Santa Cruz Observatory (SCO) measurement programme.

Parameter	Start date	Present Instrument	Frequency
In situ Reactive Gases			
O ₃	Nov 2004	UV Photometry Teco 49-C	Continuous (1')
CO	Mar 2006	Non-dispersive IR abs. Thermo 48C-TL	Continuous (1')
SO ₂	Mar 2006	UV fluorescence Thermo 43C-TL	Continuous (1')
NO-NO ₂ -NO _x	Mar 2006	Chemiluminescence Thermo 42C-TL	Continuous (1')
Ozone and UV (managed by the AEMET's Special Networks Service at the nearby Met Center)			
Column O ₃	Oct 2000	Brewer Mark-II#033	> ~20/day
Spectral UV	Oct 2000	Brewer Mark-II#033	~30'
SO ₂	Oct 2000	Brewer Mark-II#033	~30'
Column aerosols			
AOD and Angstrom at 340, 380, 440, 500, 675, 870, 936, 1020 nm	Jul 2004	CIMEL CE318 sun photometer	~ 15'
Fine/Coarse AOD	Jul 2004	CIMEL CE318 sun photometer	~ 15'
Vertical Backscatter-extinction @523 nm, clouds alt. and thickness	Nov 2005	Micropulse Lidar MPL-3, SES Inc., USA (co-managed with INTA (www.inta.es))	1'
Vertical backscatter-extinction @910 nm, cloud alt. and thickness	Jan 2011	Vaisala CL-51 Ceilometer	1'
Radiation			
Global Radiation	Feb 2006	Pyranometer CM-11 Kipp & Zonen	Continuous (1')
Direct Radiation	Feb 2006	Pyrheliometer EPPLEY	Continuous (1')
Diffuse Radiation	Feb 2006	Pyranometer CM-11 Kipp & Zonen	1'
UV-B Radiation	Aug 2011	Yankee YES UVB-1 Pyranom. (managed by the AEMET's Special Networks Service at the nearby Met Centre)	1'
Column Water Vapour			
Vertical relative humidity	Dec 1963	Vaisala RS-92	Daily at 00 and 12 UTC
Precipitable Water Vapour (PWV)	Mar 2003	CIMEL CE318 sun photometer	~ 15'
PWV	Jan 2009	GPS/GLONASS GRX1200PRO receiver	15' (ultra-rapid orbits) and 1 h (precise orbits)
PWV (total column) over SCO when cloudless skies Cloud base heights when cloudy skies over SCO	Jun 2014	1 SIELTEC Sky Temperature Sensor (infrared thermometer prototype)	Every 30" during the complete day

Meteorology*			
Vertical profiles of T, RH, P, wind direction and speed, from sea level to ~30 km altitude	Dec 1963	RS92+GPS radiosondes launched at Güimar automatic radiosonde station (WMO GUAN station #60018) (managed by the Meteorological Centre of Santa Cruz de Tenerife)	Daily at 00 and 12 UTC
Temperature	Jan 2002	VAISALA HMP45C	1'
Relative humidity	Jan 2002	VAISALA HMP45C	1'
Wind Direction and speed	Jan 2002	RM YOUNG wind sentry 03002	1'
Pressure	Jan 2002	VAISALA PTB100A	1'
Rainfall	Jan 2002	THIES CLIMA Tipping Bucket	1'
Aerobiology			
Pollens and spores	Oct 2004	Hirst, 7-day recorder VPPS 2000 spore trap (Lanzoni S.r.l.).	Continuous (1 h resolution)

* Meteorological data of Santa Cruz de Tenerife official station, 1 km distant, are also available since 1922.

3.3 Botanic Observatory

The Botanic Observatory (BTO) is located 13 km north-east of IZO at 114 m a.s.l. in the Botanical Garden of Puerto de la Cruz (Fig. 3.10). BTO is hosted by the Canary Institute of Agricultural Research (ICIA). The Botanic Observatory includes the following facilities:

- Ozone Sounding Monitoring Laboratory: equipped with a Digicora MW31 receiver with Vaisala METGRAPH data acquisition and processing software and a surface ozone analyser
- Launch container: equipped with a Helium supply system used for ozonesonde balloons filling.

In addition to the ozonesonde measurements, there is a fully equipped automatic weather station (temperature, relative humidity, pressure, precipitation, wind speed and direction), a global irradiance pyranometer and a surface ozone analyser (also used for additional ECC electrochemical sondes ground checking). For details of the BTO measurement programme, see Table 3.5.



Figure 3.10. Image of Botanic Observatory (BTO).

Table 3.5. Botanic Observatory (BTO) measurement programme.

Parameter	Start date	Present Instrument	Frequency
Reactive Gases and ozonesondes			
Vertical profiles of O ₃ , PTU, and wind direction and speed, from sea level to ~33 km altitude	Nov 1992	ECC-A6+RS92/GPS radiosondes	1/week (Wednesdays)
Surface O ₃	May 2011	UV Photometry Teco 49-C	1'
Radiation			
Global Radiation	May 2011	Pyranometer CM-11 Kipp & Zonen	1'
Column Water Vapour			
Precipitable Water Vapour (PWV)	Jan 2009	GPS/GLONASS GRX1200PRO receiver	15' (ultra-rapid orbits) and 1h (precise orbits)
Meteorology			
Temperature	Oct 2010	VAISALA F1730001	1'
Relative humidity	Oct 2010	VAISALA F1730001	1'
Wind direction and speed	Oct 2010	VAISALA WMT700	1'
Pressure	Oct 2010	VAISALA PMT16A	1'
Rainfall	Oct 2010	VAISALA F21301	1'

3.4 Teide Peak Observatory

The Teide Peak Observatory (TPO) is located at 3555 m a.s.l. at the [Teide Cable Car](#) terminal in the Teide National Park (Fig. 3.11). TPO was established as a satellite station of IZO primarily for radiation and aerosol observations at very high altitude. TPO station, together with Jungfraujoch (3454 m a.s.l.) in Switzerland, are the highest permanent radiation observatories in Europe.

This measurement site provides radiation and aerosol information under extremely pristine conditions and in conjunction with measurements at SCO and IZO allows us to study the variation of global radiation, UV-B and aerosol optical depth from sea level to 3555 m a.s.l. In addition to radiation and aerosol measurements, there is a meteorological station and a water vapour isotopologues analyser. Full details of the measurement programme are given in Table 3.6.

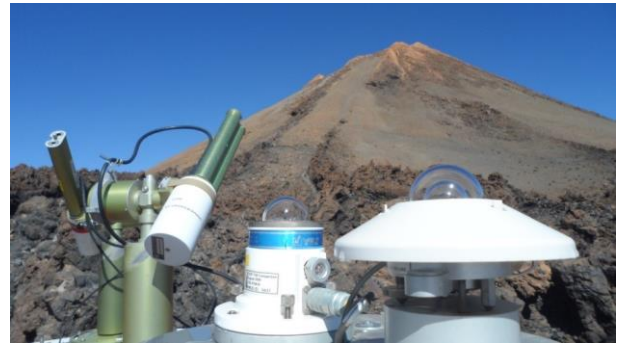

Figure 3.11. Measurements at Teide Peak Observatory.

Table 3.6. Teide Peak Observatory (TPO) measurement programme.

Parameter	Start date	Present Instrument	Frequency
Column aerosols			
AOD and Angstrom at 340, 380, 440, 500, 675, 870, 936 and 1020 nm	Jun 1997	CIMEL CE318 sun photometer (Co-managed with the University of Valladolid Atmospheric Optics Group)	~ 15' (during Apr-Oct)
Fine/Coarse AOD Fine mode fraction	Jun 1997	CIMEL CE318 sun photometer (Co-managed with the University of Valladolid Atmospheric Optics Group)	~ 15' (during Apr-Oct)
Radiation			
Global Radiation	Jul 2012	Pyranometer CM-11 Kipp & Zonen	1'
UVB Radiation	Jul 2012	Pyranometer Yankee YES UVB-1	1'
Water vapour			
Water vapour isotopologues (δD and $\delta^{18}O$)	June 2013	Picarro L2120-I δD and $\delta^{18}O$ analyser	Continuous (2'')
Meteorology			
Wind direction and speed	Oct 2011	THIES CLIMA Sonic 2D	Wind direction and speed
Temperature	Aug 2012	VAISALA HMP45C	1'
Relative humidity	Aug 2012	VAISALA HMP45C	1'
Pressure	Aug 2012	VAISALA PTB100A	1'

3.5 Computing Facilities and Communications

The computing facilities and communications form an integral component of all measurement programmes and activities in the Izaña Atmospheric Research Center. In the IARC headquarters there is a temperature controlled room hosting server computers devoted to different automatic and continuous tasks (NAS, modelling, spectra inversion, etc.) for the research groups. Details of the computing facilities are given in Table 3.7.

Table 3.7. IARC computing facilities.

Computing Hardware				
	Storage	Virtualization	Modelling	Total
H.D.	34 TB	12 TB	10 TB	56 TB
Cores	7	28	68	105
RAM	12 GB	56 GB	46 GB	114 GB

The IARC headquarters has internet access through a double optical fibre connection (20 Mb/s) to AEMET headquarters in Madrid, one of them acting as back-up. IZO is real time connected to IARC headquarters through a wifi-radio link (54 Mb/s) of 34 km. A EUMETCast (EUMETSAT's Broadcast System for Environmental Data) reception station is available at SCO. It consists of a multi-service dissemination system based on standard Digital Video Broadcast (DVB) technology. Most of the satellite information is received from this system (see Section 13 for more details).

3.6 Staff

Activities universal to all measurement programmes such as operation and maintenance of IARC facilities, equipment, instrumentation, communications and computing facilities are made by the following staff:

Ramón Ramos (AEMET; Head of Scientific instrumentation and infrastructures)

Enrique Reyes (AEMET; IT development specialist)

Néstor Castro (AEMET; IT specialist)

Antonio Cruz (AEMET; IT specialist)

Rocío López (AEMET; IT specialist)

Sergio Afonso (AEMET; Meteorological Observer-GAW Technician)

Concepción Bayo (AEMET; Meteorological Observer-GAW Technician)

Rubén del Campo Hernández (AEMET; Meteorological Observer-GAW Technician)

Virgilio Carreño (AEMET; Meteorological Observer-GAW Technician)

Cándida Hernández (AEMET; Meteorological Observer-GAW Technician)

Dr Fernando de Ory (AEMET; Meteorological Observer-GAW Technician)

4 Greenhouse Gases and Carbon Cycle

4.1 Main Scientific Goals

The main goal of this IARC programme is to carry out highly accurate atmospheric greenhouse gas (GHG) in situ continuous measurements at IZO in order to contribute to the GAW-WMO programme, following the GAW recommendations and guidelines. Additional goals are: 1) to establish with precision the long-term evolution of the GHGs in the atmosphere, as well as their daily, seasonal and inter-annual variability; 2) to improve and develop the GHG measurement systems of IZO as well as the associated raw data processing software; 3) to carry out studies and research concerning the measurement and evolution of the GHGs in the atmosphere (e.g. Gomez-Pelaez et al., 2013); and 4) to attend GHG GAW meetings and participate in the establishment of GHG GAW recommendations and guidelines.

4.2 Measurement Programme

Table 4.1 gives details of the atmospheric greenhouse gases currently measured at IZO using in situ analysers (owned by AEMET) and some details about their measurement schemes. Carbon monoxide is not a greenhouse gas but affects the methane cycle. Tropospheric ozone acts as a greenhouse gas but it is included in the IARC reactive-gas programme. Details of the in situ measurement systems and data processing can be found in Gomez-Pelaez et al. (2006, 2009, 2011, 2012, 2013, and 2014). Additional information can be found in the last IZO GHG GAW scientific audit reports: Scheel (2009), Zellweger et al. (2009), and Zellweger et al. (in preparation).

Additionally, weekly discrete flask samples have been collected for the National Oceanic and Atmospheric

Administration-Earth System Research Laboratory-Global Monitoring Division Carbon Cycle Greenhouse Gases Group (NOAA-ESRL-GMD CCGG) [Cooperative Air Sampling Network](#) (since 1991). The participation consists of weekly discrete flask sample collection at IZO and subsequent shipping of the samples to NOAA-ESRL-GMD CCGG. The air inside the flasks has been measured for the following gas specie mole fractions: 1) CO₂, CH₄, CO, and H₂ since 1991; N₂O and SF₆ since 1997 (both sets measured by NOAA/ESRL/GMD CCGG); 2) Isotopic ratios Carbon-13/Carbon-12 and Oxygen-18/Oxygen-16 in carbon dioxide since 1991 (measured by the Stable Isotope Lab of INSTAAR); 3) Methyl chloride, benzene, toluene, ethane, ethene, propane, propene, i-butane, n-butane, i-pentane, n-pentane, n-hexane and isoprene since 2006 (measured by INSTAAR). Two-week integrated samples of atmospheric carbon dioxide have also been collected for the Heidelberg University (Institute of Environmental Physics, [Carbon Cycle Group](#)) since 1984 to measure the C-14 isotopic ratio in carbon dioxide.



Figure 4.1. CH₄, N₂O and SF₆ laboratory, IZO.

Table 4.1. Atmospheric greenhouse gases measured in situ at IZO and measurement schemes used.

Gas	Start Date	Analyser	Model	Ambient air measurement frequency	Reference gas/es and measurement frequency	Reference gas/es calibration frequency
CO ₂	1984	NDIR	Licor 7000 Licor 6252	Continuous Continuous	3 RG every hour 3 RG every hour	Biweekly using 4 LS
CH ₄	1984	GC-FID	Dani 3800 Varian 3800	2 injections/hour 4 injections/hour	1 RG every 30 min 1 RG every 15 min	Biweekly using 2 LS
N ₂ O	2007	GC-ECD	Varian 3800	4 injections/hour	1 RG every 15 min	Biweekly using 5 LS
SF ₆	2007	GC-ECD	Varian 3800	4 injections/hour	1 RG every 15 min	Biweekly using 5 LS
CO	2008	GC-RGD	Tr.An. RGA-3	3 injections/hour	1 RG every 20 min	Biweekly using 5 LS

Reference gas/es (RG), Laboratory Standard (LS)

4.3 Summary of remarkable results during the period 2012-2014

This programme has continued performing continuous high-quality greenhouse gas measurements and annually submitting the data to the WMO GAW World Data Centre for Greenhouse Gases (WDCGG), where data are publicly available through internet and DVD supports, and also global data summaries are published (e.g., WDCGG, 2014). The complete time series for CO₂, CH₄, N₂O, and SF₆ at IZO are shown in Fig. 4.2.

IARC has also continued contributing to the data products GLOBALVIEW and OBSPACK led by NOAA-ESRL-GMD CCGG (e.g., Cooperative Global Atmospheric Data Integration Project, 2013), as well as collaborating with the associated CO₂ surface flux inversions CarbonTracker (e.g., CarbonTracker Team, 2015), CarbonTracker Europe and MACC, which follows the procedure described in Chevallier et al. (2010).

The PI of this IARC programme has continued attending the biannual “WMO/IAEA Meeting on Carbon Dioxide, Other Greenhouse Gases, and Related Measurement Techniques”.

The last one was held in Beijing, China, June 10-14, 2013, where he gave the presentation Gomez-Pelaez et al. (2014). IARC-AEMET participated in the “5th WMO/IAEA Round Robin Comparison Experiment” for the parameters CO₂, CH₄, N₂O, SF₆ and CO, and its measurement results showed a good compatibility with the WMO CCL (NOAA-ESRL-GMD CCGG) results.

During September 2013 – February 2014, the GHG measurement systems of IARC were audited by EMPA (GAW WCC for CH₄, CO, CO₂ and O₃) and the GAW WCC for N₂O. This was the first audit performed at IZO in which CO₂ was audited (the WCC for CO₂ did not exist when the previous audits were performed) and a travelling instrument was used to perform atmospheric measurements during several months to be compared with the atmospheric measurements performed with the IARC measurement systems (additionally to the usual comparison of measurements performed on travelling standards). The audit report is still in preparation.

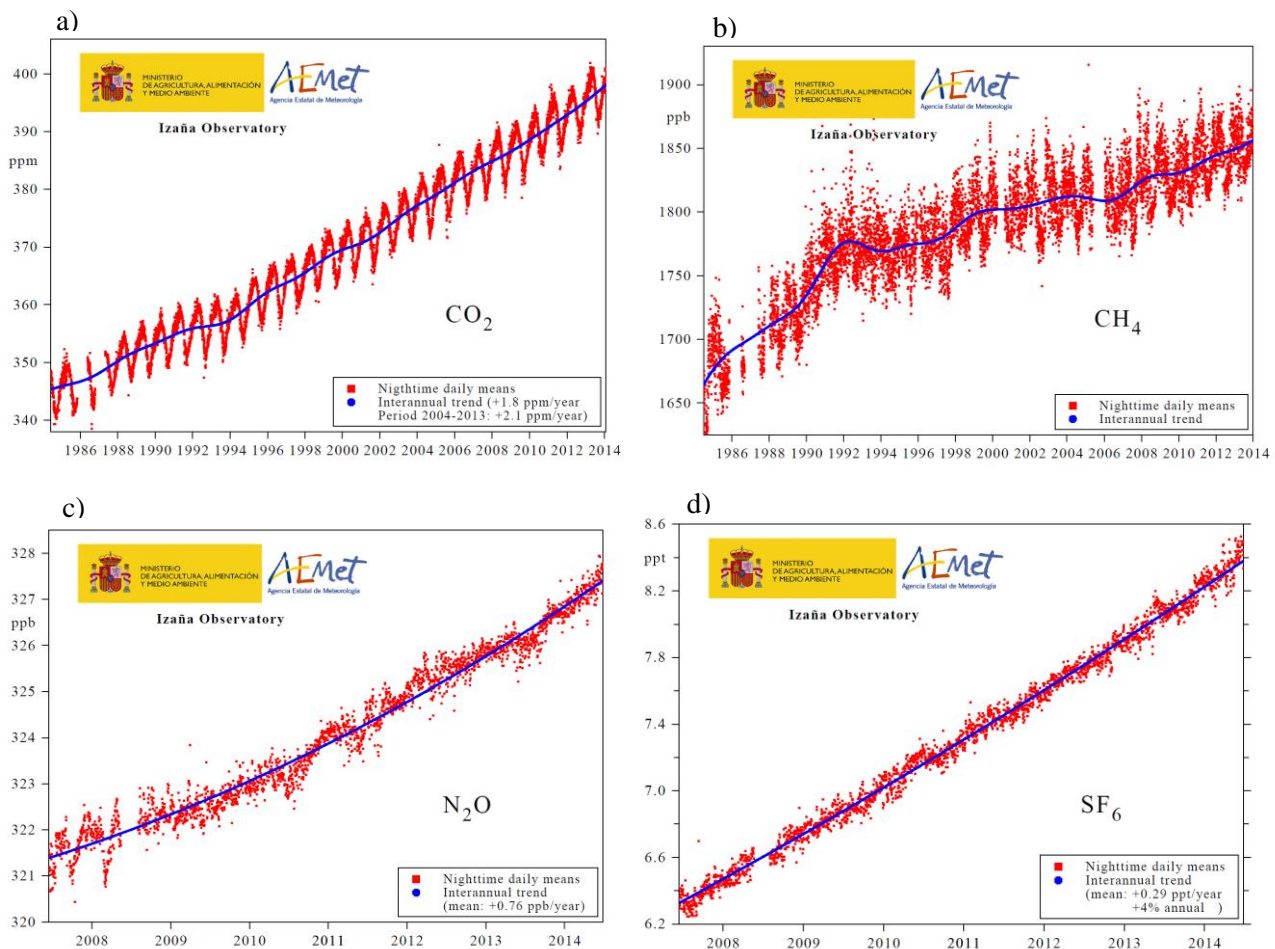

Figure 4.2. Izaña Atmospheric Observatory time series for a) CO₂, b) CH₄, c) N₂O and d) SF₆.

The IARC GHG measurement systems were adapted during 2012-2013 to be able to measure also discrete samples collected on board aircrafts using a quasi automatic sampler (see more details about the first measurement campaign in Section 4.4.2).

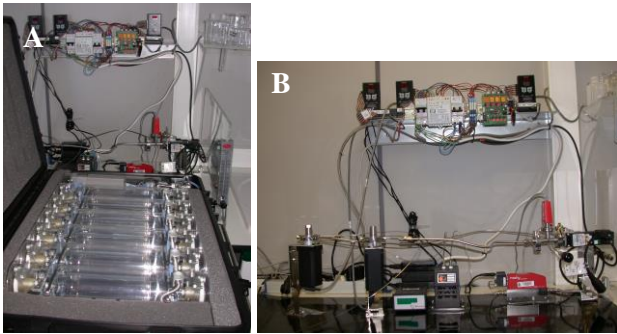

Figure 4.3. A) Detail of the interior of one of the packages that contain flasks where the air samples collected on board the aircraft are stored. B) Image showing part of the system installed at IARC for extracting the flask air samples and distributing them to the different IZO in situ instruments to measure them.

The PI of this programme conducted a study that led to the publication of the article Gomez-Pelaez et al. (2013), entitled “A statistical approach to quantify uncertainty in carbon monoxide measurements at the Izaña global GAW station: 2008–2011” in the scientific review Atmospheric Measurement Techniques. In this paper, the IZO CO measurement system configuration (based on a Reduction Gas Analyser), the response function, the calibration scheme, the data processing, the IZO 2008–2011 CO nocturnal time series, and the mean diurnal cycle by months are presented.

A rigorous uncertainty analysis for carbon monoxide measurements carried out at IZO is developed, which could be applied to other GAW stations. The combined standard measurement uncertainty is determined taking into consideration four contributing components: 1) the uncertainty of the WMO standard gases interpolated over the range of measurement; 2) the uncertainty that takes into account the agreement between the standard gases and the response function used; 3) the uncertainty due to the repeatability of the injections; and 4) the propagated uncertainty related to the temporal consistency of the response function parameters (which also takes into account the covariance between the parameters).

A fifth type of uncertainty called representation uncertainty is considered when some of the data necessary to compute the temporal mean are absent. Any computed mean has also a propagated uncertainty arising from the uncertainties of the data used to compute the mean. The laws of propagation, which depend on the type of uncertainty component (random or systematic), are shown. Finally, in situ hourly means are compared with simultaneous and collocated NOAA flask samples, and the uncertainty of the differences

is computed and used to determine whether the differences are significant.

An enumeration of the developments and changes introduced in the IARC GHG measurement systems and raw data processing software before June 2013 is reported in sections 3 and 4 of Gomez-Pelaez et al. (2014), whereas those introduced after that date will be detailed in the extended abstract associated with an IARC presentation intended to be presented at the “18th WMO/IAEA Meeting on Carbon Dioxide, Other Greenhouse Gases, and Related Measurement Techniques (GGMT-2015)” (13-17 Sept 2015, La Jolla, California, USA).

4.4 Participation in Scientific Projects and Campaigns/Experiments

4.4.1 Participation in Scientific Projects

AEMET-IARC was member of the project “ICOS Spain. Implementación 2010. AIC10-A-000474” funded by the Spanish Science and Innovation Ministry (end-date 31 December 2012). In the context of this project, the PI of the IARC GHG programme attended in 2012 the meetings “4th ICOS Atmosphere Workshop (Gif-sur-Yvette, France, 16 and 17 February 2012)” and “5th ICOS Atmosphere Workshop (Arona, Italy, 8 and 9 October 2012)”, where he co-authored the presentations Gomez-Pelaez et al. (2012) and Hammer et al. (2012), respectively. He participated in working group 6 (“Quality management for atmospheric ICOS stations”) constituted in the first of the indicated meetings, and contributed to the document “ICOS Atmospheric Station Specifications” (Integrated Carbon Observation System -Atmospheric Thematic Center, 2014).

The IARC GHG measurement programme also participates in the funded projects NOVIA and VALIASI, which are led by the IARC FTIR measurement programme (see more details about these projects in Section 7), and co-authored 4 peer-review papers and 16 conference contributions led by the latter programme and its partner from the Karlsruhe Institute of Technology (KIT).

Finally, on 10 December 2014 the project “Equipamiento para la Monitorización e Investigación de Gases de Efecto Invernadero y Aerosoles en la estación Global VAG (Vigilancia Atmosférica Global) de Izaña (Tenerife). AEDM13-3E-1773” was approved and funded by the Spanish Ministry of Economy and Competitiveness (“Fondos F.E.D.E.R.”). A significant part of these funds will be destined to acquire a CO₂/CH₄/CO/H₂O CRDS analyser for the IARC GHG measurement programme.

4.4.2 Participation in the MUSICA/AMISOC campaign

From 21 July to 1 August 2013, the Spanish National Institute for Aerospace Technology (INTA) research aircraft C-212 carried out seven scientific flights above the ocean to the south of IZO. These flights were funded by the research projects Multi-platform remote Sensing of Isotopologues for investigating the Cycle of Atmospheric water (MUSICA) (led by KIT) and AMISOC (led by INTA) and freighted on board instrumentation of both projects (for the measurement of isotopes in water vapour and of aerosols).

The IARC took the opportunity to install on board the aircraft for the first time a quasi automatic air sampler. In each flight, the sampler was used to take twelve air samples from different altitudes uniformly distributed from 150 m a.s.l. to 6500 m a.s.l.. The greenhouse gas content of these samples was analysed later at IZO using the IARC instrumentation for the high-precise and accurate measurement of greenhouse gas mole fractions. This is the first time that greenhouse gas atmospheric vertical profiles have been measured in situ in the surroundings of the Canary Islands.



Figure 4.4. MUSICA/AMISOC campaign.

4.5 References

CarbonTracker Team; (2015): Simulated observations of atmospheric carbon dioxide from CarbonTracker release CT2013B(ospack_co2_1_CARBONTRACKER_CT2013B_2015-02-05), including measured values from a multi-laboratory compilation of CO₂ observations; NOAA Earth System Research Laboratory, Global Monitoring Division. <http://dx.doi.org/10.15138/G3WC7B>

Chevallier, F., P. Ciais, T. J. Conway, T. Aalto, B. E. Anderson, P. Bousquet, E. G. Brunke, L. Ciattaglia, Y. Esaki, M. Fröhlich, A. Gomez, A. J. Gomez-Pelaez, L. Haszpra, P. B. Krummel, R. L. Langenfelds, M. Leuenberger, T. Machida, F. Maignan, H. Matsueda, J. A. Morguá, H. Mukai, T. Nakazawa, P. Peylin, M. Ramonet, L. Rivier, Y. Sawa, M. Schmidt, L. P. Steele, S. A. Vay, A. T. Vermeulen, S. Wofsy, D. Worthy, CO₂ surface fluxes at grid point scale estimated from a global 21 year reanalysis of atmospheric measurements, *J. Geophys. Res.*, 115, D21307, doi:10.1029/2010JD013887, 2010

Cooperative Global Atmospheric Data Integration Project. 2013, updated annually. Multi-laboratory compilation of

synchronized and gap-filled atmospheric carbon dioxide records for the period 1979-2012 (ospack_co2_1_GLOBALVIEW-CO2_2013_v1.0.4_2013-12-23). Compiled by NOAA Global Monitoring Division: Boulder, Colorado, U.S.A. Data product accessed at <http://dx.doi.org/10.3334/OBSPACK/1002>

Gomez-Pelaez, A.J., Ramos, R., Perez-delaPuerta, J., "Methane and carbon dioxide continuous measurements at Izaña GAW station (Spain)" in GAW Report (No. 168) of the "13th WMO/IAEA Meeting of Experts on Carbon Dioxide Concentration and Related Tracers Measurement Techniques (Boulder, Colorado, USA, 19-22 September 2005)", edited by J.B. Miller, World Meteorological Organization (TD No. 1359), 180-184, 2006

Gomez-Pelaez, A.J., Ramos, R., "Installation of a new gas chromatograph at Izaña GAW station (Spain) to measure CH₄, N₂O, and SF₆" in GAW Report (No. 186) of the "14th WMO/IAEA meeting of experts on Carbon dioxide, other greenhouse gases, and related tracers measurement techniques (Helsinki, Finland, 10-13 September 2007)", edited by Tuomas Laurila, World Meteorological Organization (TD No. 1487), 55-59, 2009

Gomez-Pelaez, A.J., Ramos, R., "Improvements in the Carbon Dioxide and Methane Continuous Measurement Programs at Izaña Global GAW Station (Spain) during 2007-2009", in GAW report (No. 194) of the "15th WMO/IAEA Meeting of Experts on Carbon Dioxide, Other Greenhouse Gases, and Related Tracer Measurement Techniques (Jena, Germany; September 7-10, 2009)", edited by Willi A. Brand, World Meteorological Organization (TD No. 1553), 133-138, 2011

Gomez-Pelaez, A.J., R. Ramos, V. Gomez-Trueba, R. Campo-Hernandez, E. Dlugokencky, T. Conway "New improvements in the Izaña (Tenerife, Spain) global GAW station in-situ greenhouse gases measurement program" in GAW report (No. 206) of the "16th WMO/IAEA Meeting on Carbon Dioxide, Other Greenhouse Gases, and Related Measurement Techniques (GGMT-2011) (Wellington, New Zealand, 25-28 October 2011)", edited by Gordon Brailsford, World Meteorological Organization, 76-81, 2012

Gomez-Pelaez, A.J., Morguá, J.A., Curcoll, R., Cuevas, E., Ramos, R., Rodó, X., Sanz, M.J., "Future ICOS-Spain atmospheric stations". 4th ICOS Atmosphere Workshop, Gif-sur-Yvette, France, 16 and 17 February 2012

Gomez-Pelaez, A. J., Ramos, R., Gomez-Trueba, V., Novelli, P. C., and Campo-Hernandez, R.: A statistical approach to quantify uncertainty in carbon monoxide measurements at the Izaña global GAW station: 2008–2011, *Atmos. Meas. Tech.*, 6, 787-799, doi:10.5194/amt-6-787-2013, 2013

Gomez-Pelaez, A.J., R. Ramos, V. Gomez-Trueba, R. Campo-Hernandez, E. Reyes-Sanchez: "Izaña Global GAW station greenhouse-gas measurement programme. Novelties and developments during October 2011-May 2013" in GAW report (No. 213) of the "17th WMO/IAEA Meeting on Carbon Dioxide, Other Greenhouse Gases, and Related Measurement Techniques (Beijing, China, June 10-14, 2013)", edited by P. Tans and C. Zellweger, World Meteorological Organization, 77-82, 2014

Hammer, S., A. Gomez-Pelaez, M. Schmidt, A. Jordan, T. Laurila, R. Curcoll and A. Manning "Working group 6: Quality management for atmospheric ICOS stations". 5th ICOS Atmosphere Workshop, Arona, Italy, 8 and 9 October 2012

Integrated Carbon Observation System (Atmospheric Thematic Center), "ICOS Atmospheric Station Specifications", edited by O. Laurent, version 1, October 2014. List of contributors:

Baum, S., Delmotte, M., Dvorska, A., Gerbig, C., Gomez-Pelaez, A., Grant, A., Hammer, S., Hanus, V., Hazan, L., Jordan, A., Laurent, O., Laurila, T., Lavric, J., Levin, I., Lindroth, A., Manning, A., Morgui, J.A., O'Doherty, S., Paris, J. D., Pavelka, M., Pilegaard, K., Plass-Duelmer, C., Ramonet, M., Reiter, I., Rivier, L., Schmidt, M., Steinbacher, M., Tarniewicz, J. Vermeulen, A., Wastine, B. A.

Scheel, H.E. (2009), System and Performance Audit for Nitrous Oxide at the Global GAW Station Izaña, Tenerife, Spain, November 2008, WCC-N2O Report 2008/11, http://www.aemet.izana.org/publications/Rep_WCCN2O_2008_IZOAudit.pdf

Zellweger, Christoph, et al. (2009), System and Performance Audit of Surface Ozone, Carbon Monoxide, Methane and Nitrous Oxide at the Global GAW Station Izaña, Spain, March 2009, WCC-Empa Report 09/1, http://gaw.empa.ch/audits/IZO_2009.pdf

World Data Centre for Greenhouse Gases (WDCGG), WMO WDCGG Data Summary, GAW Data (Volume IV-Greenhouse Gases and Other Atmospheric Gases), WDCGG No. 38, Japan Meteorological Agency in Co-operation with World Meteorological Organization, 2014.

4.6 Staff

Ángel Gómez-Peláez (AEMET; Head of programme)

Ramón Ramos (AEMET; Head of Infrastructure)

Rubén del Campo Hernández (AEMET; Meteorological Observer- GAW Technician)

Vanessa Gómez-Trueba (Air Liquide)

5 Reactive Gases and Ozonesondes

5.1 Main Scientific Goals

The main scientific objectives of this programme are:

- Long-term monitoring of reactive gases (CO, NO_x, SO₂) in both the free troposphere (FT) and the Marine Boundary Layer (MBL) to support other measurement programmes at IARC.
- Long-term monitoring and analysis of tropospheric O₃, CO, NO_x and SO₂ in the FT and the MBL.
- Air quality studies in urban and background conditions.
- Analysis of long-range transport of pollution (e.g. transport of anthropogenic and wildfire pollution from North America).
- Study of the impact of dust and water vapour on tropospheric O₃.
- Analysis and characterization of the Upper Troposphere-Lower Stratosphere (UTLS).
- Analysis of Stratosphere-Troposphere Exchange processes.

5.2 Measurement Programme

The measurement programme of reactive gases (O₃, CO, NO_x and SO₂) includes long-term observations at IZO, SCO and BTO (see Tables 3.2, 3.4 and 3.5) and ozonesonde vertical profiles at Tenerife (now at BTO). In addition, IARC (through AEMET and INTA) has a long-term collaboration with the Argentinian Meteorological Service (SMN) and in the framework of this collaboration, ozone vertical profiles are measured at Ushuaia GAW station (Argentina) (see Section 21).

Surface O₃ measurements started in 1987 at IZO (Fig. 5.1), CO in 2004, and SO₂ and NO_x measurements were implemented in 2006. At SCO, surface O₃ measurements started in 2001, and CO, SO₂ and NO_x programmes were also implemented in 2006.

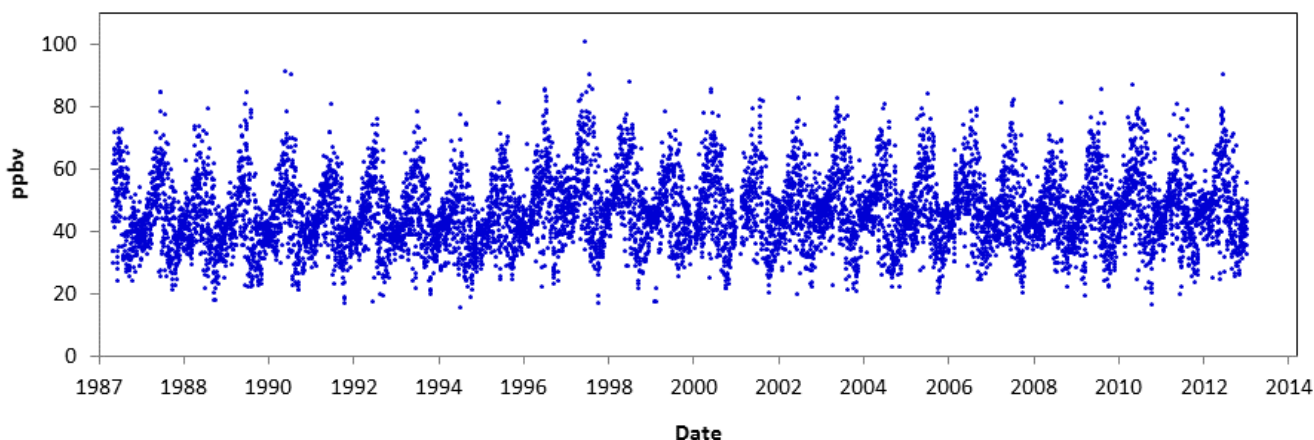

Figure 5.1. Long-term daily (night period) surface ozone at IZO.

The surface O₃ programme is considered a particularly important programme at IZO due to both free troposphere conditions of the site and the quality and length of the data series. Surface O₃ data at IZO have been calibrated against references that are traceable to the US National Institute for Standards and Technology (NIST) reference O₃ photometer (Gaithersburg, Maryland, USA). The surface O₃ programme at IZO has been audited by the World Calibration Centre for Surface Ozone, Carbon Monoxide and Methane (WCC-Ozone-CO-CH₄-EMPA) in 1996, 1998, 2000, 2004, 2009 and 2013. EMPA's audit reports are available at <http://www.empa.ch/gaw/audits/IZOyyyy.pdf> (where "yyyy" is the year). The audits were performed according to the "Standard Operating Procedure (SOP) for performance auditing O₃ analysers at global and regional WMO-GAW sites", WMOGAW Report No. 97. Details of this programme developed over nearly 30 years are described in González (2012) and Cuevas et al. (2013).

Concerning NO_x and SO₂, the measurement programmes have been implemented following methodologies established by the US Environmental Protection Agency (US EPA) and the European Union (2008/50/CE). These agencies have also established QA/QC protocols (e.g., US EPA, 600/4-77-027a, 1977; UNE-EN standards). These recommendations have been considered during the implementation of the reactive gases programme at SCO and IZO. We have also followed GAW protocols and procedures.

In relation to CO, this component is measured with high accuracy at IZO by the Greenhouse Gases and Carbon Cycle Programme, using the gas chromatography/reduction gas detection (GC/RGD) technique, and following the GAW recommendations (see Section 4). A detailed description of the programme can be found in Gómez-Peláez et al. (2013).

CO is measured with non-dispersive IR absorption technique at IZO within the Reactive Gases Programme to identify local pollution events. At SCO measurements are also performed with this technique for air quality research.

Concerning NO_x and SO₂ measurements, the instruments operating at IZO usually measure below the detection limit (50 pptv) during the night-time period when we can ensure background conditions. However, these measurements are quite useful for studies of local or regional pollution during daylight modulated by valley-mountain breeze, and to understand the impact of regional pollution. A detailed description of these measurement programmes, including quality control and quality assurance protocols is provided by González (2012).

The ozone vertical profiles programme was initiated in November 1992 using the Electrochemical concentration cell (ECC) ozonesonde technique. The equipment and launching stations used in this programme are indicated in Table 5.1. Once a week, ozonesonde launches are now performed at BTO, 13 km distance from IZO in a straight line. This programme provides ozone profiles from the ground to the burst level (generally between 30 and 35 km) with a resolution of around 100 metres. A detailed description of this programme and results can be found in Cuevas et al. (1994), Smit et al. (1995), and Sancho et al. (2001). The frequency of ozone soundings in this station is significantly expanded during intensive campaigns.



Figure 5.2. Ozonesonde station located at BTO (left), and moment of balloon release (right).

The main features of the ozonesonde system are the following:

- Sensor: ECC-A6
- Radiosonde: RS-92
- Balloon: TOTEX TA 1200
- Receiver: DigiCora MW31
- Wind system: GPS

The ozonesondes are checked before launching with a Ground Test with Ozonizer/Test Unit TSC-1 (see Section 3X). A constant mixing ratio above burst level is assumed for the determination of the residual ozone if an altitude equivalent to 17 hPa has been reached. The integrated ozone column (starting at 2400 m a.s.l.), for those ozone sondes that reach a burst level of at least 17 hPa, is ratioed with the same column amount measured with the Brewer#157 at IZO (WMO ozone station #300).

Table 5.1. Ozonesonde Programme equipment used in different time periods and launching stations since November 1992.

Instrument manufacturer and model	Frequency	Period/Launching station
<p>OZONESONDES: Nov 1992 – Sep 1997: Science Pump Corp. Model ECC5A Sep 1997 – Dec 2014: Science Pump Corp. Model ECC6A</p> <p>GROUND EQUIPMENT: Nov 1992 – Oct 2010: VAISALA DigiCora MW11 Rawinsonde Oct 2010 – Dec 2014: VAISALA DigiCora III SPS 313 Workstation</p> <p>RADIOSONDES: Nov 1992 – Oct 1997: VAISALA RS80-15NE (Omega wind data) Oct 1997 – Sep 2006: VAISALA RS80-15GE (GPS Wind data) Sep 2006-Dec 2014: VAISALA RS92-SGP (GPS Wind data)</p>	1/week (Wed)	Nov 1992 – Oct 2010: From Santa Cruz Station Oct 2010 – Feb 2011: From Santa Cruz/ BTO (In alternation launches) Feb 2011 – Dec 2014: From BTO Station

Most of the Brewer/ECC coefficients fall in the 0.95-1.05 range. This coefficient is only used as a quality control parameter but it is not applied for ozone correction. The NDACC quality control and quality assurance requirements are fulfilled, and data is routinely archived into NDACC database.

5.3 Summary of remarkable results during the period 2012-2014

5.3.1 Long-term surface O₃ data series assessment

The surface O₃ data series, which began in 1987, is one of the longest in the world under free troposphere conditions, and therefore has contributed to several studies of global long-term ozone assessments. The most recent study is that of Oltmans et al. (2013). The time series of the observations at IZO shows a rapid increase to higher values in the mid to late 1990s, which may reflect a shift in the phase of the North Atlantic Oscillation (NAO) altering the transport pattern to Izaña (Cuevas et al., 2013). The latter paper presents an analysis of the 22-year ozone series (1988-2009) at IZO. A climatology of O₃ transport pathways using backward trajectories shows that higher O₃ values are associated with air masses travelling above 4 km altitude from North America and North Atlantic Ocean, while low O₃ is transported from the Saharan boundary layer (Fig. 5.3). O₃ data have been also compared with PM₁₀, 210Pb, 7Be potential vorticity (PV) and CO. A good correlation between O₃ and CO in winter is found, supporting the hypothesis of long-range transport of photochemically generated O₃ from North America. Aged air masses, in combination with sporadic inputs from the upper troposphere, are observed in spring, summer and autumn,

while in summer-time high O₃ values seem to be the result of stratosphere-to-troposphere (STT) exchange in regions neighbouring the Canary Islands. Since 1995-1996, the NAO has changed from a predominantly high positive phase to alternating between negative, neutral or positive phases. This change results in an increased flow of the westerlies in the mid-latitude and subtropical North Atlantic, thus favouring the transport of O₃ and its precursors from North America, and a higher frequency of storms over North Atlantic, with a likely higher frequency of STT events in mid latitudes. These processes lead to an increase of tropospheric O₃ in the subtropical North Atlantic region after 1996, which has been reflected in surface O₃ records at IZO.

5.3.2 Air quality and health

The reactive gases programme has contributed to studies on the impact of atmospheric pollution on health. For example, Domínguez-Rodríguez et al. (2013a) analysed the effects caused by exposure to contaminants in the gas phase and atmospheric particles in ambient air in patients hospitalized for acute coronary syndrome (ACS). They concluded that exposure to high concentrations of sulphur dioxide is a precipitating factor for admission of patients with ACS and Significant Obstructive Lesions (SOL). In the same line of research, Domínguez-Rodríguez et al. (2013b) have focused on studying the links between the exposure to air pollutants and the presence of inflammatory molecules and oxidative stress in patients with ACS. They analyzed whether the level of environmental exposure is an independent prognostic factor in terms of overall and cardiovascular mortality, myocardial infarction or unstable angina.

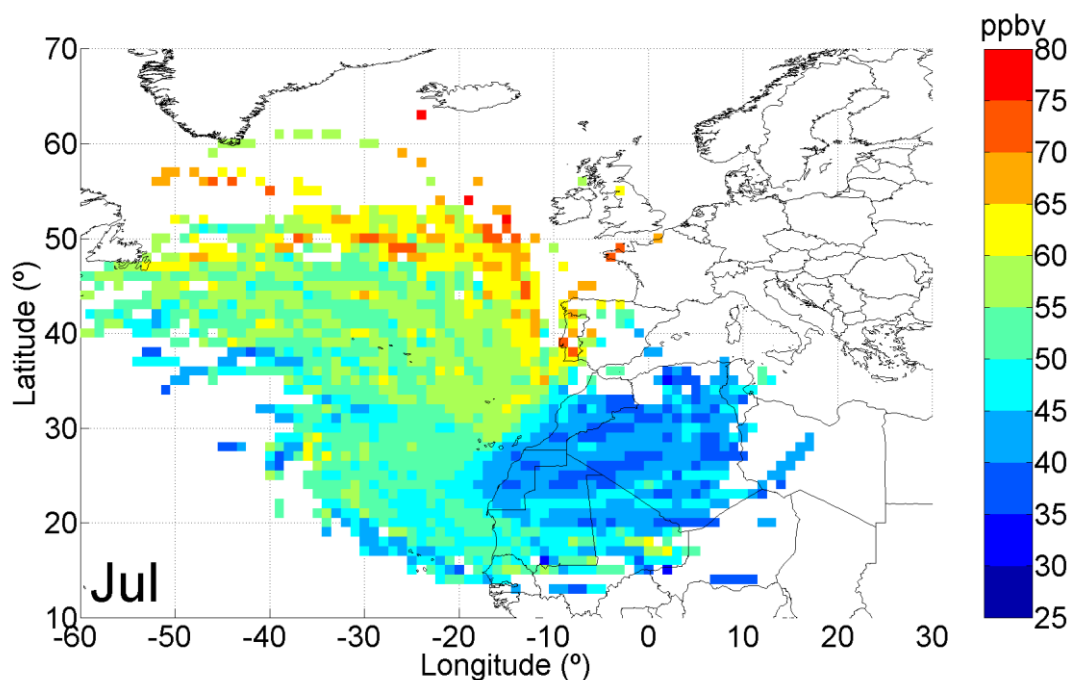

Figure 5.3. Surface O₃ Mean Concentrations At Receptor (MCAR) plot for July for the period 1988–2009. Colour bars indicate O₃ concentration in ppbv. Reprinted from Cuevas et al. (2013).

González and Rodríguez (2013) used reactive gases data at SCO in their study on the contribution of vehicle exhausts, ships and an oil refinery emission to the ambient air concentration of ultrafine particles (UFPs). Their study was based on a data set of particle number coarser than 2.5nm (N), black carbon (BC), gaseous pollutants (NO_x, SO₂, CO and O₃), PM_{2.5} and PM₁₀. The observed relationship between N, BC and gaseous pollutants allowed UFP concentrations to be segregated in a set of components linked to each source.

5.3.3 Characterization of the subtropical tropopause region

The main features of the subtropical tropopause region over Tenerife are examined and characterized by Rodríguez-Franco and Cuevas (2013) using 20 years (1992–2011) of ozonesonde data and European Center for Medium-Range Weather Forecasts ERA-Interim potential vorticity (PV) and zonal wind speed reanalysis.

This study introduces new insights since high-resolution vertical profiles allowed a detailed description of the subtropical tropopause break and the associated subtropical jet stream (STJ), where models fail to properly simulate the upper troposphere–lower stratosphere (UTLS). The subtropical UTLS, which is a rather thick (~8 km) and complex region is analysed by evaluating four different tropopause definitions: thermal (TT); Cold Point (CPT); ozone (OT) and dynamical (DT) tropopauses (Fig. 5.4).

A novel method to determine the DT based on the vertical gradient of Lait's modified PV is presented. This method represents an analytical improvement for DT determination from model reanalysis. The concept of a second DT and a second OT has been introduced for the first time, showing an excellent agreement with the second thermal tropopause and the cold point tropopauses.

The 14.3 km height level is used to differentiate between tropical and extratropical UTLS regimes, intimately linked to the position of the STJ. There is fairly good consistency between all the defined tropopauses under the double tropopause scheme, except in spring, when the OT is observed at lower levels due to frequent baroclinic instabilities in the upper troposphere.

In winter, altitude differences between OT, DT, and TT resulted from poleward STJ excursions forced by blocking systems over the North Atlantic. Analysis of the tropopause inversion layer showed distinctive features for tropical and midlatitude tropopauses.

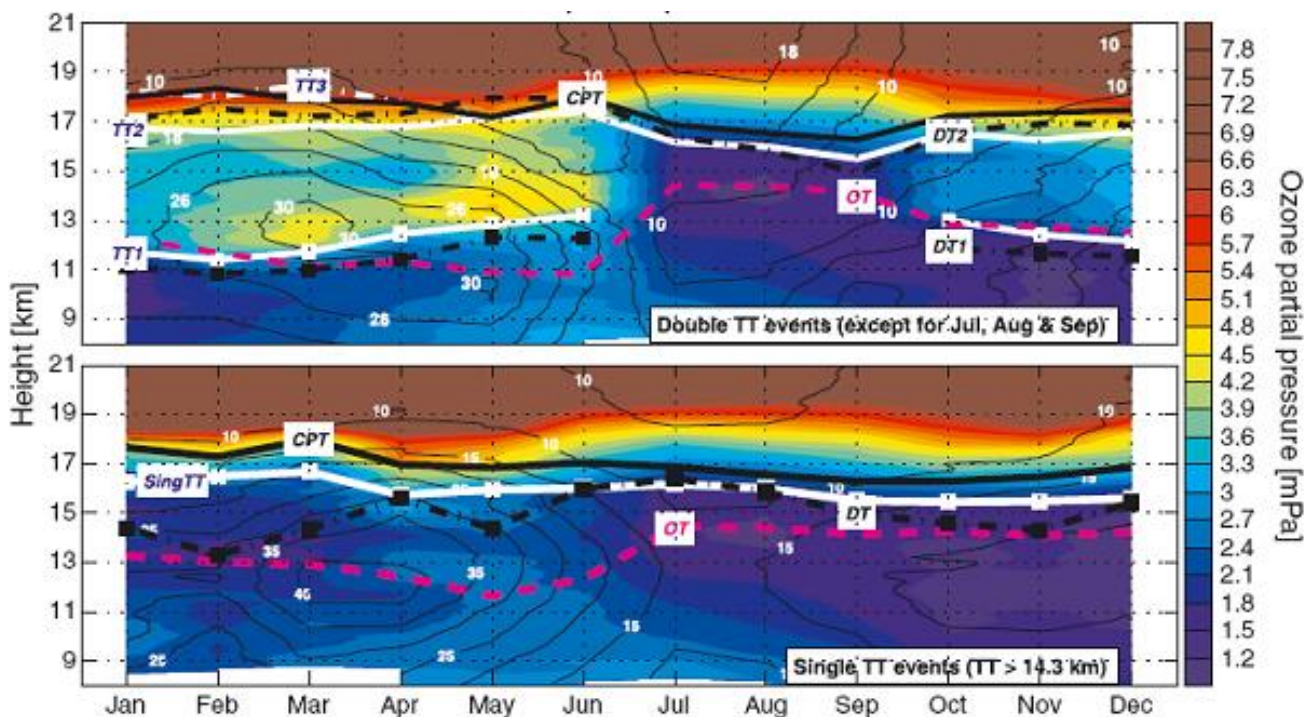

Figure 5.4. Time-height cross section of O₃ partial pressure (mPa) and wind speed contours (m s⁻¹) from 8 to 21 km height for multiple (upper panel) and single (lower panel) thermal tropopause events. The vertical coordinate is tropopause based. The different tropopause types are shown labelled with their corresponding acronym. TT1, TT2 and TT3 are the first, second and third thermal tropopauses, respectively; DT1 and DT2 are the first and second dynamical tropopause, respectively; OT is the ozone tropopause, and CPT is the Cold-Point tropopause (reprinted from Rodríguez-Franco and Cuevas, 2013).

5.3.4 Relationship between tropospheric O₃, water vapour and mineral dust

A total of 157 O₃ vertical profiles from ozone soundings launched at Tenerife over 13 summers are analysed together with aerosol optical depth as a discrimination tool to differentiate clean atmospheric conditions and dusty conditions under the presence of the Saharan Air Layer (SAL) (Andrey et al., 2014) (Fig. 5.5). The results show that O₃ mixing ratios on SAL days are systematically lower than those during clean conditions, with a difference of as much as 35%. An analysis of independent total ozone columns from ground based and satellite spectrometers confirm the observed O₃ reductions. A comparison of the vertical shape of the O₃ reductions with the vertical distribution of dust loading and precipitable water vapour shows that a better correlation is found with the total amount of water present in the air. This finding suggests that the latter component plays a role in the observed O₃ reduction within the SAL. This is a challenging topic that has not been sufficiently investigated in previous studies, mainly based on case studies or short-term campaigns.

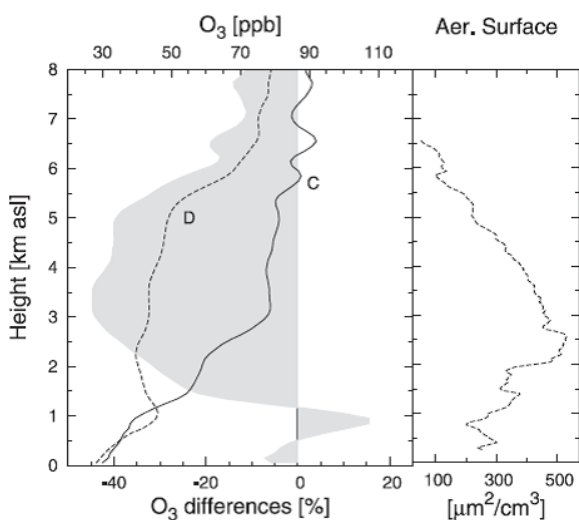

Figure 5.5. Average O₃ profiles under clean (C) and dusty (D) conditions from flights carried out during the airborne campaigns conducted in summer 2005 and 2006 (left panel). Mean dust load (right panel). Reprinted from Andrey et al. (2014).

5.3.5 Long-path averaged mixing ratios of O₃ and NO₂ in the free troposphere using MAXDOAS

A new method, named Modified Geometrical Approach (MGA), was developed by the INTA group working at IZO in collaboration with the IARC to obtain surface mixing ratios of O₃ and NO₂ trace gases in the free troposphere using the Multi Axis Differential Optical Absorption Spectroscopy (MAXDOAS) technique (see Section 11). This method has been applied and validated at IZO using O₃ and NO₂ data from in situ instruments. The NO₂ validation

has been performed in free troposphere conditions for the first time.

5.3.6 Other contributions

García et al. (2012) in their study on long-term evolution of subtropical ozone profile time series (1999–2010) obtained with ground based FTIR (see Section 7) at IZO, used daily intercomparisons with ECC sonde profiles to assess precision estimates of FTIR retrievals. They conclude that the FTIR system is able to resolve four independent ozone layers with a precision of better than 6% in the troposphere and of better than 3% in the lower, middle and upper stratosphere. The assessment of the accuracy of the FTIR O₃ vertical profiles has been possible thanks to the long series of O₃ vertical profiles from the ozonesonde program.

García et al. (2014) presented a climatology of new particle formation (NPF) events at high altitude in the subtropical North Atlantic, analysing number size distributions (10–600 nm), reactive gases (SO₂, NO_x and O₃), several components of solar radiation and meteorological parameters, measured at IZO. NPF is associated with the transport of gaseous precursors from the boundary layer by orographic buoyant upward flows that perturb the low free troposphere during daytime. García et al. (2014) demonstrated that during NPF events, SO₂, UV radiation and upslope winds showed higher values than during non-events. The overall data set indicates that SO₂ plays a key role as precursor, although other species seem to contribute during some periods.

5.4 Participation in Scientific Projects and Campaigns/Experiments

5.4.1 Atmospheric Minor Species relevant to the Ozone Chemistry at both sides of the Subtropical jet (AMISOC)

The Atmospheric Minor Species relevant to the Ozone Chemistry at both sides of the Subtropical jet (AMISOC) project intensive campaign was held on Tenerife in summer 2013. This project, managed by INTA, aims to improve the knowledge of the minor constituents of the atmosphere playing a role in the ozone chemistry. Details of the project and the intensive campaign carried out on Tenerife can be found at the AMISOC [web page](#).

5.4.2 MUSICA intensive campaign in July 2013

This campaign was carried out by the Institute for Meteorology and Climate Research (IMK-ASF), Karlsruhe Institute of Technology, with the IARC FTIR programme, and financed by the MUSICA project. More details on the MUSICA intensive campaign can be found in Schneider et al. (2015).

5.5 References

- Andrey, J., E. Cuevas, M.C. Parrondo, S. Alonso-Pérez, A. Redondas, M. Gil-Ojeda: Quantification of ozone reductions within the Saharan air layer through a 13-year climatologic analysis of ozone profiles, *Atmospheric Environment*, 48, 28-34, 2014.
- Cuevas, E., K. Lamb, A. Bais, Total Ozone Contents derived by Different Instruments and Soundings, *Meteorological Publications No 27*, Finnish Meteorological Institute, 105-119, Helsinki, 1994.
- Cuevas, E., González, Y., Rodríguez, S., Guerra, J. C., Gómez-Peláez, A. J., Alonso-Pérez, S., Bustos, J., and Milford, C.: Assessment of atmospheric processes driving ozone variations in the subtropical North Atlantic free troposphere, *Atmos. Chem. Phys.*, 13, 1973-1998, doi:10.5194/acp-13-1973-2013, 2013.
- Domínguez-Rodríguez, A., Abreu-Afonso, J., González, Y., Rodríguez, S., Juárez-Prera, R. A., Jiménez-Sosa, A., Abreu-González, P., Avanzas, P., Relationship between short-term exposure to atmospheric sulfur dioxide and obstructive lesions in acute coronary syndrome, *Med. Clín.*, 140(12): 537-541, 2013a.
- Domínguez-Rodríguez, A., S. Rodríguez, P. Abreu, R. Juárez, P. Avanzas. Impact of air pollution on inflammation, oxidative stress and 1-year prognosis in patients hospitalized for acute coronary syndrome: design of the AIRACOS study, *Med. Clin. (Barc)*, 141(12):529-32. doi: 10.1016/j.medcli.2013.05.024, 2013b.
- García, M. I., Rodríguez, S., González, Y., and García, R. D.: Climatology of new particle formation at Izaña mountain GAW observatory in the subtropical North Atlantic, *Atmos. Chem. Phys.*, 14, 3865-3881, doi:10.5194/acp-14-3865-2014, 2014.
- García, O. E., Schneider, M., Redondas, A., González, Y., Hase, F., Blumenstock, T., and Sepúlveda, E.: Investigating the long-term evolution of subtropical ozone profiles applying ground-based FTIR spectrometry, *Atmos. Meas. Tech.*, 5, 2917-2931, doi:10.5194/amt-5-2917-2012, 2012.
- Gomez, L., Navarro-Comas, M., Puentedura, O., Gonzalez, Y., Cuevas, E., and Gil-Ojeda, M.: Long-path averaged mixing ratios of O₃ and NO₂ in the free troposphere from mountain MAX-DOAS, *Atmos. Meas. Tech.*, 7, 3373-3386, doi:10.5194/amt-7-3373-2014, 2014.
- Gomez-Pelaez, A. J., Ramos, R., Gomez-Trueba, V., Novelli, P. C., and Campo-Hernandez, R.: A statistical approach to quantify uncertainty in carbon monoxide measurements at the Izaña global GAW station: 2008-2011, *Atmos. Meas. Tech.*, 6, 787-799, doi:10.5194/amt-6-787-2013, 2013.
- González, Y., Levels and origin of reactive gases and their relationship with aerosols in the proximity of the emission sources and in the free troposphere at Tenerife, PhD Thesis, Technical Note N° 12, AEMET, NIPO 281-12-016-1, July 2012.
- González, Y. and Rodríguez, S.: A comparative study on the ultrafine particle episodes induced by vehicle exhaust, a crude oil refinery and ship emissions, *Atmospheric Research* 120-121, 43-54, 2013.
- Oltmans, S., Lefohn, A., Shadwick, D., Harris, J., Scheel, H., Galbally, I., Tarasick, D., Johnson, B., Brunke, E., Claude, H., Zeng, G., Nichol, S., Schmidlin, F., Davies, J., Cuevas, E., Redondas, A., Naoe, H., Nakano, T., and Kawasato, T.: Recent tropospheric ozone changes - A pattern dominated by slow or no growth, *Atmos. Environ.*, 67, 331-351, 2013.
- Rodríguez-Franco, J. J., and Cuevas, E., Characteristics of the subtropical tropopause region based on long-term highly-resolved sonde records over Tenerife, *J. Geophys. Res. Atmos.*, 118, doi:10.1002/jgrd.50839, 2013.
- Sancho, J.M., S. Afonso, E. Cuevas, Programa de Ozonosondeos del Observatorio Atmosférico de Izaña, Nota Técnica n° 3 del Observatorio Atmosférico de Izaña, Centro de Publicaciones, Ministerio de Medio Ambiente, I.S.B.N. 84-8320-196-8, Madrid, 2001.
- Smit, H.G.J., W. Sträter, D. Kley, E. Cuevas, Ozone Profiles at Jülich, Germany during 1993/1994 and at Santa Cruz de Tenerife, Spain in August 1993, *Berichte des Forschungszentrums Jülich GmbH KFA*, 3078, Germany, 1995.
- Schneider, M., González, Y., Dyrhoff, C., Christner, E., Wiegeler, A., Barthlott, S., García, O. E., Sepúlveda, E., Hase, F., Andrey, J., Blumenstock, T., Guirado, C., Ramos, R., and Rodríguez, S.: Empirical validation and proof of added value of MUSICA's tropospheric δD remote sensing products, *Atmos. Meas. Tech.*, 8, 483-503, doi:10.5194/amt-8-483-2015, 2015.

5.6 Staff

- Dr Emilio Cuevas (AEMET; Head of programme)
Dr Yenny González (AEMET; Research Scientist)
Marina Jover (SIELTEC; Technician)
Elba Rodríguez (AEMET; Research Scientist)
Dr Sergio Rodríguez (AEMET; Research Scientist)
Ángel Gómez-Peláez (AEMET; Research Scientist)
Dr Omaira García (AEMET; Research Scientist)
Juan José Rodríguez-Franco (AEMET; Research Scientist)
Ramón Ramos (AEMET; Head of Infrastructure)
Sergio Afonso (AEMET; Meteorological Observer-GAW Technician)
Rubén del Campo Hernández (AEMET; Meteorological Observer- GAW Technician)
Virgilio Carreño (AEMET; Meteorological Observer-GAW Technician)

6 Total Ozone Column and Ultraviolet Radiation

6.1 Main Scientific Goals

The main scientific objective of this programme is to obtain the total ozone column (TOC) and ultraviolet (UV) spectral radiation with the highest precision and long-term stability that the current technology and scientific knowledge can achieve. To reach this objective the group uses three interconnected areas. The base is the instrumentation; this is supported by strict QA/QC protocols that require laboratory calibrations and theoretical modelling. Finally, web-oriented [databases](#) are developed for dissemination of the observational data.

6.2 Measurement Programme

Measurements of total ozone and spectral ultraviolet radiation began in May 1991 in IZO with the installation of Brewer spectrometer #033. Ozone profile measurements were added in September 1992 with two daily (sunrise and sunset) vertical ozone profiles obtained with the Umkehr technique. In July 1997 a double Brewer #157 was installed at IZO and run in parallel with Brewer #033 for six months. In 2003 a second double Brewer #183 was installed and designated the travelling reference of the Regional Brewer Calibration Center for Europe (RBCC-E) (see Section 17 for

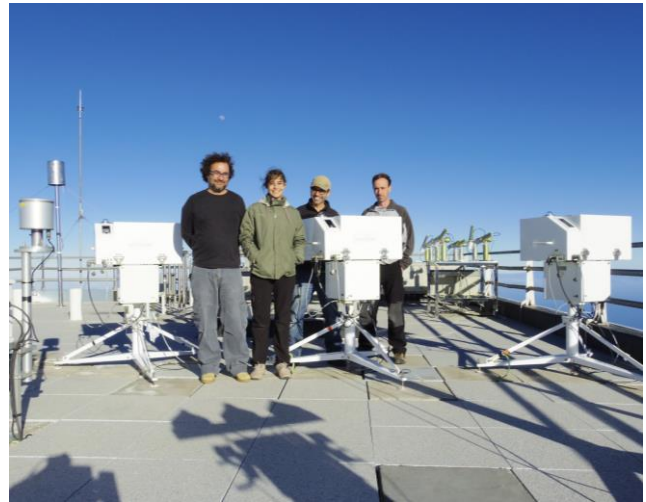

Figure 6.1. Members of the Total Ozone and UV radiation programme with the RBCC-E Brewer spectrophotometer triad located at IZO.

more details). In 2005 a third double Brewer #185 was installed and completes the reference triad of the RBCC-E (Fig. 6.1). The measurement programme was completed with the installation of a Pandora spectroradiometer in October 2011. The technical specifications of both Brewer and Pandora instruments are summarized in Table 6.1.

Table 6.1. Spectrometer specifications.

Brewer	
Slit Wavelengths	O ₃ (nm): 303.2 (Hg slit), 306.3, 310.1, 313.5, 316.8, 320.1
Mercury-calibration (O ₃ mode)	302.15 nm
Resolution	0.6 nm in UV; approx 1nm in visible
Stability	±0.01 nm (over full temperature range)
Precision	0.006 ± 0.002 nm
Measurement range (UVB)	286.5 nm to 363.0 nm (in UV)
Exit-slit mask cycling	0.12 sec/slit, 1.6 sec for full cycle
O ₃ measurement accuracy	±1% (for direct-sun total ozone)
Ambient operating temperature range	0°C a +40°C (no heater) -20°C a +40°C (with heater option) -50°C a +40°C (with complete cold weather kit)
Physical dimensions (external weatherproof container)	Size: 71 by 50 by 28 cm Weight: 34 kg
Power requirements Brewer and Tracker	3A @ 80 to 140 VAC (with heater option) 1.5A @ 160 to 264 VAC 47 to 440 Hz
Pandora	
Instrument spectral range	265-500 nm
Spectral window for NO ₂ fit	370-500 nm
Spectral resolution	±0.4 nm
Total integration time	20 s
Number of scans per cycle	50-2500
Spectral sampling of the grating spectrometers	3 pixels per FWHM

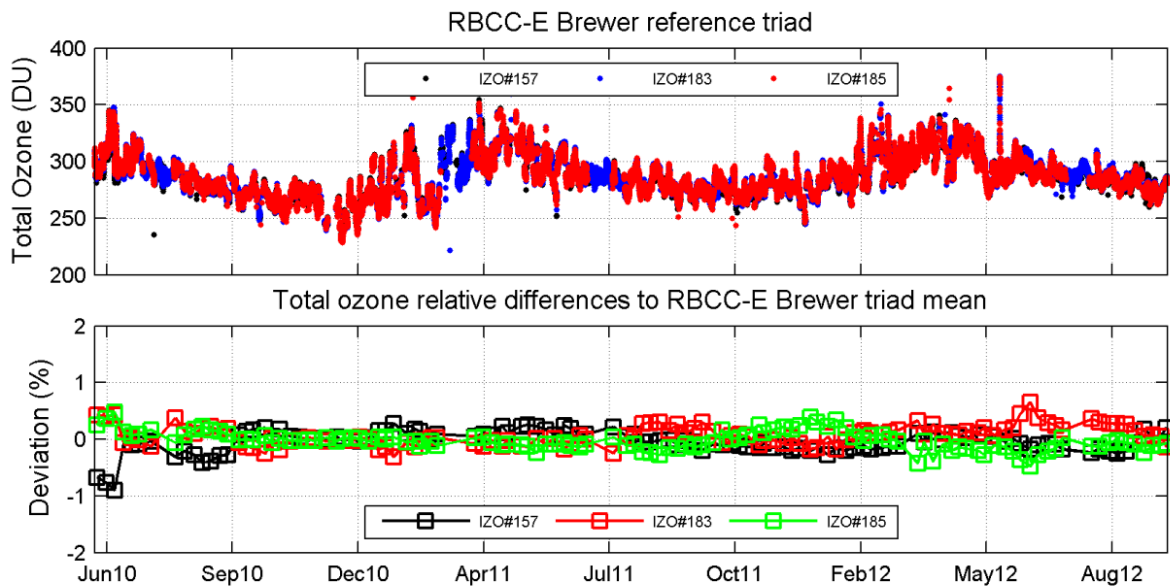

Figure 6.2. Weekly comparison of the RBCC-E triad, during the ESA CAL-VAL project showing a deviation $< 0.25\%$ on the calculated total ozone.

The spectral UV measurements are routinely quality controlled using IZO calibration facilities. The stability and performance of the UV calibration is monitored by 200W lamp tests twice a month. Every six months the Brewers are calibrated in a laboratory darkroom, against 1000W DXW lamps traceable to the World Radiation Center (WRC) standards. The SHICrivism software tool is used to analyse quality aspects of measured UV-spectra before data transfer to the databases. In addition, model to measurements comparisons are regularly done. Every year the Brewer #185 is compared with the Quality Assurance of Spectral Ultraviolet Measurements (QASUME) International portable reference spectroradiometer from PMOD/WRC.

Concerning total ozone, the Brewer triad has an exhaustive quality control in order to assure the calibration, with routine calibrations performed on a monthly basis. With this procedure, we have achieved a long-term agreement between the instruments of the triad with a precision of less than 0.25% in ozone (Fig. 6.2).

The Total Ozone programme is a part of the NDACC programme. The total ozone series for 1991-2012 is shown in Fig. 6.3 and is available at the NDACC website. We show also in Fig. 6.4 the UV observations obtained from Brewer spectrophotometer #157, available at the World Ozone and Ultraviolet Data Center (WOUDC).

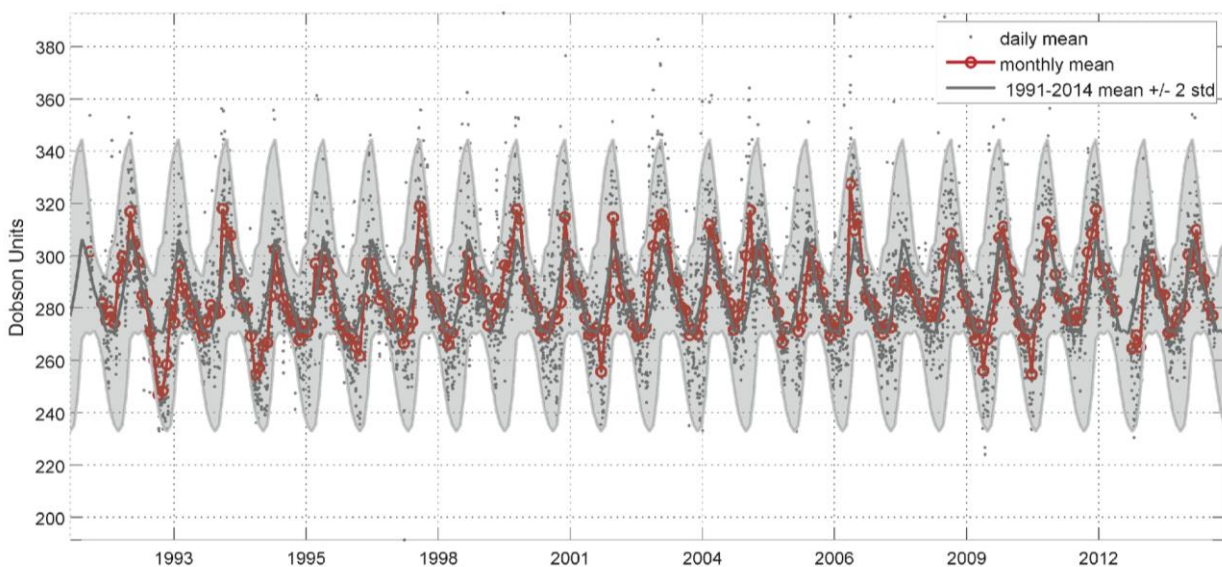

Figure 6.3. Total Ozone series at Izaña Atmospheric Observatory (1991-2014), daily mean (in grey) and monthly mean (in red), the long-term mean from the period 1991-2014 are also shown in dark grey.

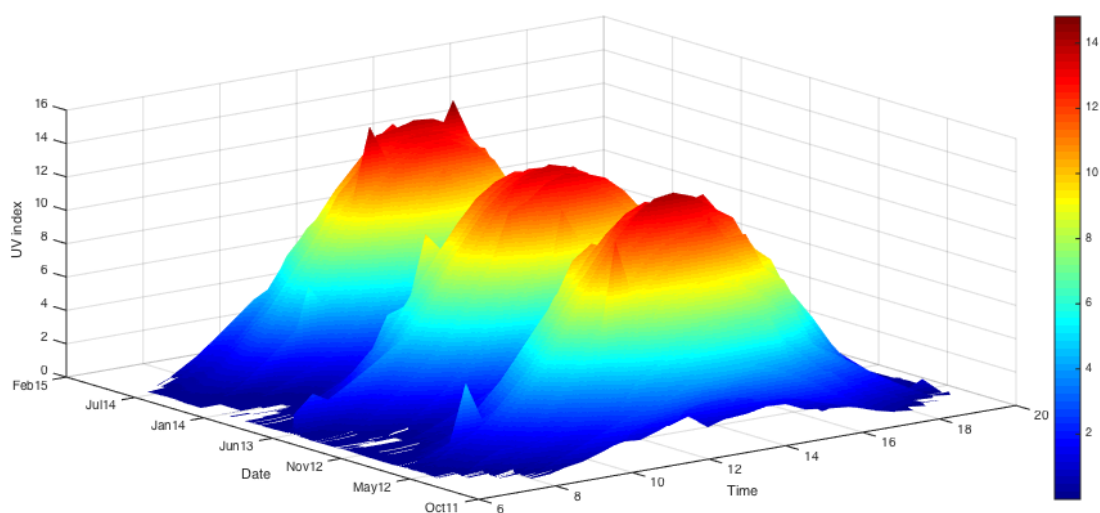

Figure 6.4. UV index during 2012-2014 calculated by Brewer #157 at Izaña Atmospheric Observatory.

6.3 Summary of remarkable results during the period 2012-2014

6.3.1 Evaluation of ozone absorption cross sections in Brewer and Dobson retrieval algorithms

The main results for this reporting period focus on the evaluation of the use of five laboratory-determined ozone absorption cross sections on the ozone retrieval of Dobson and Brewer, the reference instruments for the measurement of total ozone. The routine measurement of total ozone started in the mid-1920s with a prototype of the Dobson instrument. Until the late 1970s, this was the only instrument measuring ozone. The Brewer Ozone Spectrometer was developed in Canada during the 1970s, and became widely available in the 1980s. As observing organizations purchased these instruments and placed them in service alongside the Dobson instrument, the seasonal and systematic bias in the results became evident.

The initial difference of 4 % was removed with the adoption of absorption coefficients of a common ozone cross section in the early 1990s but seasonal and offset differences were still evident. With the consideration of the replacement of the manually operated Dobson with the automated Brewer, some “transfer function” schemes were recently considered. These methods can be quite successful, but do not fully explain the reasons for the differences.

The difference in the results of measurements made in the same place is not limited to the primary ground based networks. In 2009, the ozone community established the Absorption Cross Sections of Ozone (ACSO) committee to review the presently available cross section (XS) databases and to determine the impact of a change of the reference XS for the different instrument types (ground based and satellite) used in the individual instrument retrieval

algorithms. This ACSO committee is a joint commission of the GAW Scientific Advisory Group for Ozone and the International Ozone Commission (IO3C) of the International Association of Meteorology and Atmospheric Sciences (IAMAS).

A new set of ozone absorption coefficients for Dobson and Brewer spectrophotometers, using the five laboratory-determined ozone absorption cross sections, were calculated and compared with the previous calculations. The performances of these coefficients were evaluated using the data of simultaneous Brewer and Dobson observations during the Committee on Earth Observation Satellites (CEOS) calibration campaigns and the ozone observations at Arosa, Switzerland (Fig. 6.5). The main conclusions of the study are:

- The Brewer and Dobson instrument results agree best when the absorption coefficients used are based on the cross section developed by the University of Bremen (IUP) for the HARMONICS project (Serdyuchenko et al., 2013). The application of the temperature dependent absorption coefficients substantially reduces the seasonality found in the Arosa Brewer-Dobson record. The Daumont, Brion & Malicet (DBM) set also reduces the seasonality but the change in absolute scale in the Brewer instrument, in comparison with the Dobson results, makes its use unsuitable for the network.
- The temperature dependence values obtained confirm the hypothesis of Kerr (2002): the systematic annual differences between Brewer and Dobson are due to the different temperature dependence in the instrument’s ozone retrieval algorithm. With the Brewer, this is small: $< 0.01 \text{ \%}/^{\circ}\text{C}$. The suggestion by Kerr et al. (1988) that this difference is due to the temperature dependence in the Dobson algorithm is also confirmed.

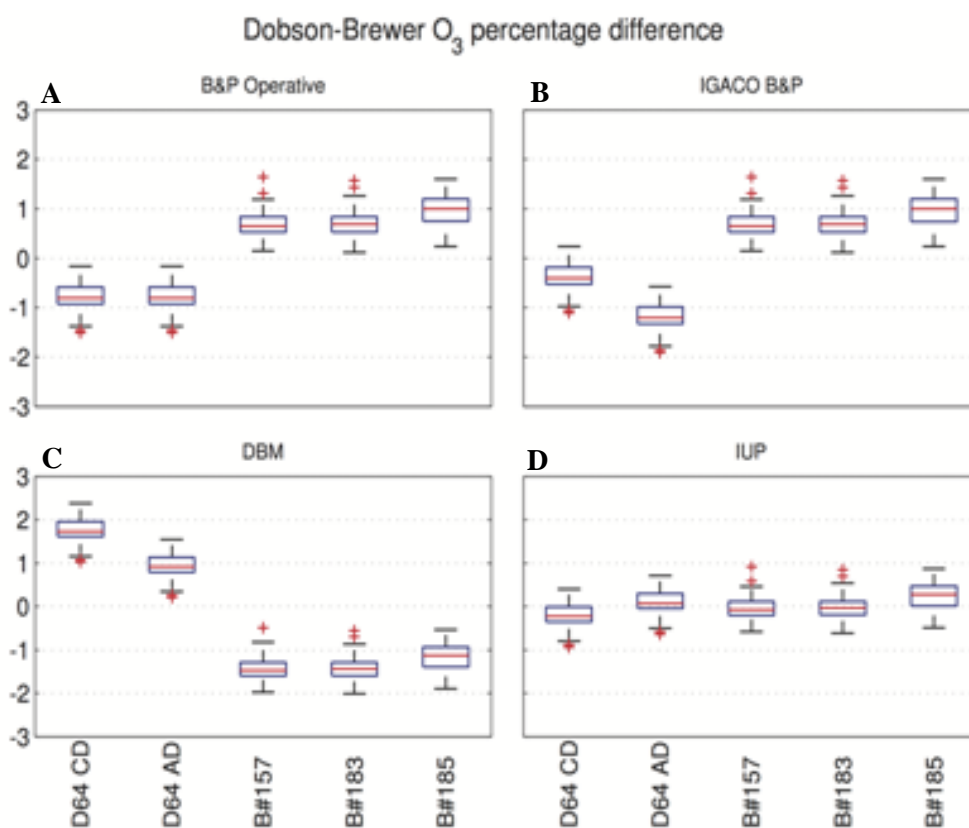

Figure 6.5. Percentage difference between Dobson (Dobson 64 AD and CD pairs) and Brewer (B#157, B#183 and B#185) for the same Langley calibration and different cross sections: A) Bass & Paur operative (B&P operative), B) the temperature quadratic fit (IGACO B&P), C) Daumont, Brion & Malicet (DBM) and D) University of Bremen (IUP).

- The Dobson record will change by less than 1 % using any one of these XS data sets. A change to the temperature dependent absorption coefficients provides the largest benefit by removing the artificial seasonality in the ozone record. The application of the temperature dependent absorption coefficients will be station dependent, as knowledge of the stratospheric temperature record over the station is required.
- The calculation of the Differential cross section (DXS) for a particular Brewer instrument is very sensitive to both the XS and the handling of the XS (editing, smoothing, etc.); these differences can be as large as 1 % in ozone.
- The existing Brewer record of TOC can be adjusted to the IUP scale using the wavelength calibration record. Using the average Brewer value the maximum uncertainty based on 123 instruments was 0.4 %; using the known operational absorption coefficient that uncertainty can be reduced to 0.1 %.

This study, performed with the support of the ESA-CALVAL project was a joint effort of the Germany, Spain, Switzerland, and USA weather services with the participation of the Dobson and Brewer WMO calibration centers, which provided the high quality Brewer and Dobson ozone observations together with the University of Bremen, which provided the new proposed ozone cross section.

To summarize, this study demonstrates that the use of the recently released Ozone Absorption Cross Section by Bremen University solves the historical differences between Dobson and Brewer spectrophotometers, the primary ground based instruments to measure Total Ozone. The application of this new cross section to the CEOS Calibration campaign data of reference instruments reduces the bias between the ozone measurements of these two instruments to near zero. Moreover, the seasonal differences of these instruments also disappear when we introduce the temperature dependence of the cross section into the retrieval algorithms. These results were published by Redondas et al. (2014).

6.3.2 Improved retrieval of nitrogen dioxide column densities by means of MKIV Brewer spectrophotometers

The group has actively participated in the development of a new algorithm to retrieve nitrogen dioxide (NO₂) column densities using Mark IV (MKIV) Brewer spectrophotometers. The method, published by Diémoz et al. (2014) includes several improvements, such as a more recent spectroscopic data set, the reduction of measurement noise, interference of other atmospheric species and instrumental settings, and a better determination of the zenith sky air mass factor. The technique was tested during a measurement campaign at IZO in September and October

2012. The results of the direct sun and zenith sky geometries were compared to those obtained by two reference instruments from the NDACC: a Fourier Transform Infrared Radiometer (FTIR) and an advanced visible spectrograph (RASAS-II) based on the differential optical absorption spectrometry (DOAS) technique.

Other relevant contributions of the group include: 1) technological aspects and new developments of the Brewer (Guirado et al., 2012; Karppinen et al. 2014); 2) long-term ozone evolution assessments (García et al., 2012a; Oltmans et al., 2013) and 3) radiation-related investigations in collaboration with other groups (García et al., 2012b; Méndez-Ramos et al., 2014).

6.4 Participation in Scientific Projects and Campaigns/Experiments

The participation in scientific projects of this measurement programme is intertwined with the activities of the WMO/GAW Regional Brewer Calibration Center for Europe (RA-VI region) (RBCC-E) (see Section 17 for more details).

6.4.1 CEOS Intercalibration of ground based spectrometers and Lidars

The main goal of the European Space Agency (ESA) CalVal project (CEOS Intercalibration of ground based spectrometers and Lidars) is to improve the quality of ground based instruments for satellite validation. The efforts during the effective period of the project have been focused on the following three major issues affecting total ozone ground based instruments (Dobson and Brewer):

- Seasonal differences between Dobson and Brewer
- Differences between ground based instruments and satellites related to Stray Light in single monochromator
- Differences between ground based instruments and satellites related to ozone cross section effects

Several field campaigns have been conducted during the 2012-2014 period to account for the issues described above (see Table 17.1). During the Absolute calibration campaigns held at IZO, Dobson and Brewer spectrophotometers were operated in parallel and calibrated using the Langley method. This allowed establishing standard calibration scales which were further transferred to the European - North African network by means of regular Brewer/Dobson Intercomparisons campaigns, mainly taking place in Southern (Huelva, Spain) and Central (Arosa, Switzerland) Europe (Khöler et al., 2012). The Nordic aspect of the project allowed the initial development of a system to compensate for straylight errors in single Brewers (Karppinen et al., 2014).

6.4.2 GAW Tamanrasset and Casablanca stations

RBCC-E has provided training and calibration services to the double Brewer installed in the GAW Tamanrasset station (Algeria) (see section 22 for more details). This station, with a long Dobson measurement record, is a unique place to study Brewer-Dobson differences over a tropical area and enables satellite validation over a desert environment (Fig. 6.6).

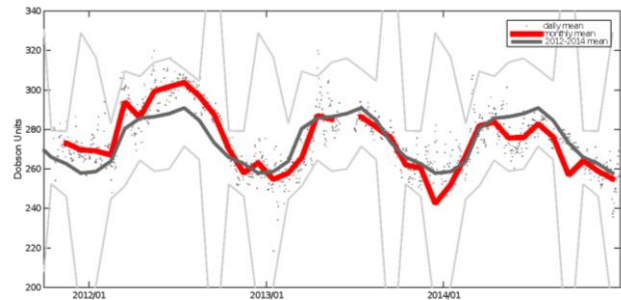

Figure 6.6. Total Ozone of Tamanrasset Station, Brewer #201, 2012-2014, daily mean (grey dots), monthly mean (in red), the mean from the period 2011-2014 are also shown in dark grey and the shaded area represents one standard deviation.

The group also supervises the Brewer operation and data processing of the Casablanca station (Morocco). The ozone observations for the year 2012 of these stations are shown in Fig. 6.7.

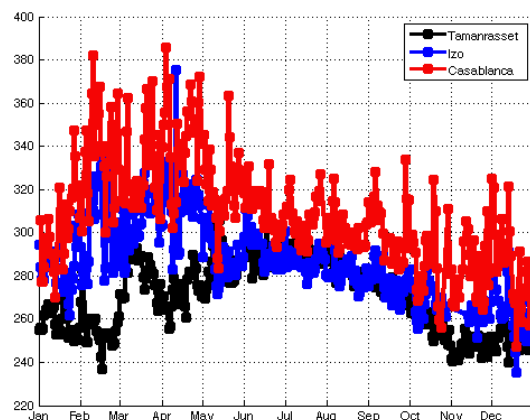

Figure 6.7. Total Ozone observations (daily mean) of IZO and the twinning stations of Tamanrasset (Algeria) and Casablanca (Morocco) in 2012.

6.4.3 EUBREWNET

EUBREWNET is a COST action (ES 1207) with the objective to establish a European Brewer Network (Fig. 6.8). The Action is based in the two European calibration Centers (RBCC-E and WRC). The RBCC-E plays a key role in the EUBREWNET, coordinating the standardization of operation and characterization and calibration of the network instrument as well as providing the Brewer database.

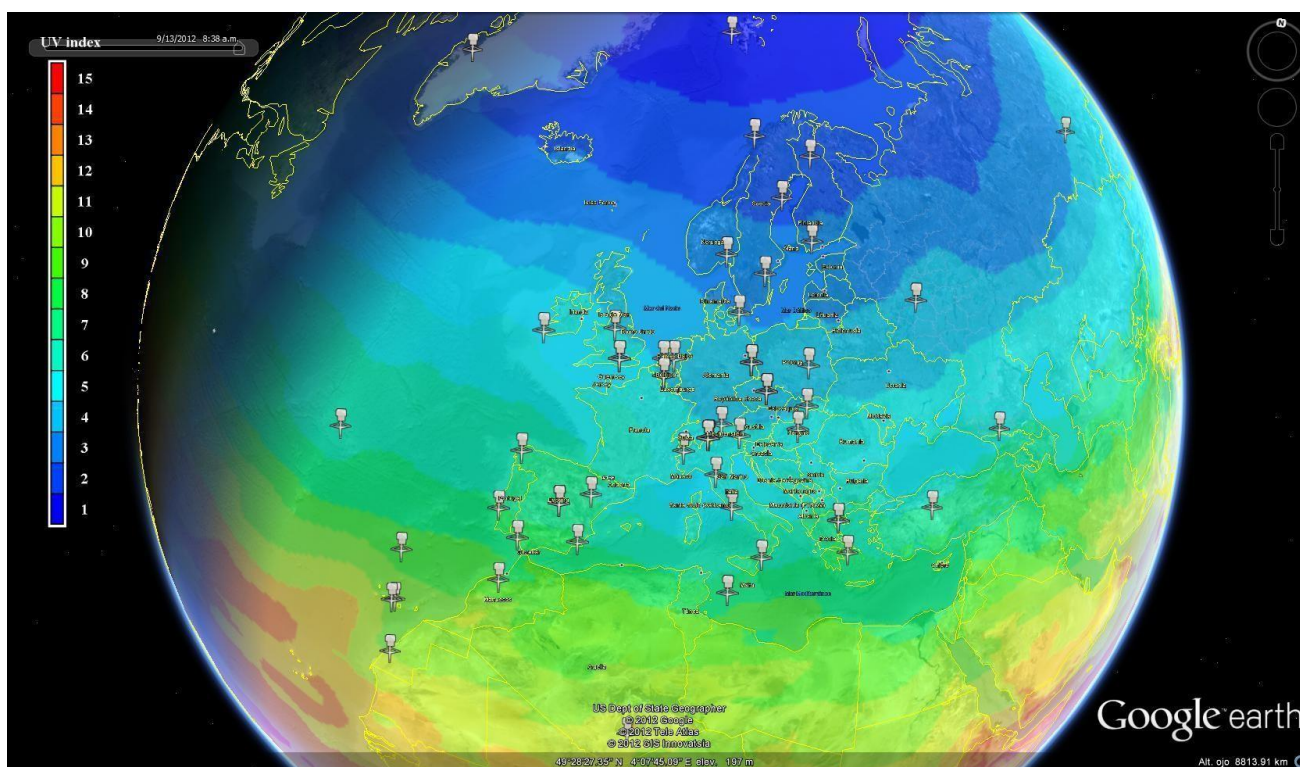

Figure 6.8. European Brewer Network (EUBREWNET), location of European Brewer stations shown over a UV forecast map, potential participants to the COST action ES 1207. The aim of the Action is to establish a coherent network of European Brewer Spectrophotometer monitoring stations in order to harmonize operations and develop approaches, practices and protocols to achieve consistency in quality control, quality assurance and coordinated operations.

The database previously developed by the RBCC-E provides the core of the newly developed database capable of providing real-time observations of the 50 participating European stations (www.eubrewnet.org).

6.4.4 ATMOZ

The Joint Research Project Traceability for atmospheric total column ozone (ATMOZ) aims to significantly enhance the reliability of total ozone column measured at the Earth surface with Dobson instruments, Brewer-Spectroradiometer and Array-Spectroradiometer. New methods of observation (techniques, instruments and software) are developed to provide traceable total ozone column measurements with an uncertainty of less than 1%.

The dissemination of the improved ozone traceability and the developed tools and methods will be achieved via a large field intercomparison of spectroradiometers organized at the end of the project in Tenerife. The participation of the RBCC-E has the objective to characterize the reference Brewer at the PTB facilities, and with this information develop the error analysis of the Brewer instrument. The improvements developed in this project will be transferred to the network instruments during RBCC-E campaigns. The publication of the calibration methodology for Brewer instruments (Brewer Calibration Standard Procedure) is the final objective for this project.

6.4.5 EarthCare Ground Base - Spectrometer Validation Network (Pandonia)

The aim of this project is to establish a network of Pandora instruments “Pandonia”. The main instrument of Pandonia will be Pandora-2S, which is currently being developed under this project as an evolution of the existing Pandora spectrometer system. The Pandonia network emphasizes: homogeneous calibration of instrumentation, low instrument manufacturing and operation costs, central data processing and formatting and quick delivery of final data products. The planned data products of Pandonia are: Total and tropospheric ozone (O₃) column, Total and tropospheric nitrogen dioxide (NO₂) column and Spectral aerosol optical depth (AOD) in the ultraviolet (>300nm) and visible range.

The reference instruments of Pandonia will be at IZO, which will also be an instrument test site together with the observation platform of the Biomedical Physics Department, Medical University Innsbruck, Innsbruck, Austria. All network instruments will be traceable to reference instruments, through intercomparison with a mobile reference unit visiting network locations. An intercomparison campaign with several instruments together at one location is also planned for 2016.

6.5 References

- Diémoz, H., Siani, A. M., Redondas, A., Savastiouk, V., McElroy, C. T., Navarro-Comas, M., and Hase, F.: Improved retrieval of nitrogen dioxide (NO₂) column densities by means of MKIV Brewer spectrophotometers, *Atmos. Meas. Tech.*, 7, 4009-4022, doi:10.5194/amt-7-4009-2014, 2014.
- García, O. E., Schneider, M., Redondas, A., González, Y., Hase, F., Blumenstock, T., and Sepúlveda, E.: Investigating the long-term evolution of subtropical ozone profiles applying ground-based FTIR spectrometry, *Atmos. Meas. Tech.*, 5, 2917-2931, doi:10.5194/amt-5-2917-2012, 2012a.
- García, R.D., V.E. Cachorro, E. Cuevas, A. Redondas, A.M. de Frutos, A. Berjón, Comparison of measured and modeled UV spectral irradiance at the Izaña station based on LibRadtran and UVA-GOA models, *Opt. Pura Apl.*, 45 (1) 11-15, Special Section: 37th AMASOM Instrumentation and Techniques, 2012b.
- Guirado, C., R. Ramos, A. de Frutos, A. Berjón, A. Redondas, C. López, V. Cachorro, E. Cuevas, R. González, S. González, M. Hernández, Optical calibration facility at the Izaña Atmospheric Research Center, *Opt. Pura Apl.*, 45 (1) 57-62, Special Section: 37th AMASOM Instrumentation and Techniques, 2012.
- Karppinen, T, A. Redondas, R.D. García, K. Lakkala, C.T. McElroy & E. Kyrö, Compensating for the Effects of Stray Light in Single-Monochromator Brewer Spectrophotometer Ozone Retrieval, *Atmosphere-Ocean*, DOI: 10.1080/07055900.2013.871499, 2014.
- Méndez-Ramos, J., P. Acosta-Mora, J.C. Ruiz-Morales, M. Sierra, A. Redondas, E. Ruggiero, L. Salassa, M.E. Borges and P. Esparza; Rare-earth doped colour tuneable up-conversion ZBLAN phosphor for enhancing photocatalysis, *Optical Materials*, November 2014.
- Oltmans, S., Lefohn, A., Shadwick, D., Harris, J., Scheel, H. Galbally, I., Tarasick, D., Johnson, B., Brunke, E., Claude, H., Zeng, G., Nichol, S., Schmidlin, F., Davies, J., Cuevas, E., Redondas, A., Naoe, H., Nakano, T., and Kawasato, T.: Recent tropospheric ozone changes - A pattern dominated by slow or no growth, *Atmos. Environ.*, 67, 331-351, 2013.
- Redondas, A., Evans, R., Stuebi, R., Köhler, U., and Weber, M.: Evaluation of the use of five laboratory-determined ozone absorption cross sections in Brewer and Dobson retrieval algorithms, *Atmos. Chem. Phys.*, 14, 1635-1648, doi:10.5194/acp-14-1635-2014, 2014.

6.6 Staff

Alberto Redondas Marrero (AEMET; Head of programme)

Virgilio Carreño (AEMET; Meteorological Observer-GAW Technician)

Juan José Rodríguez (AEMET; Research Scientist)

Marta Sierra (AEMET; Research Scientist)

Dr Sergio Fabián León Luis (AEMET; Research Scientist)

Bentorey Hernandez Cruz (University of La Laguna (ULL); Research Scientist)

Ana Peris Morel (ULL; Research Scientist)

Dr Alberto Berjón (AEMET; Research Scientist)

7 Fourier Transform Infrared Spectroscopy (FTIR)

7.1 Main Scientific Goals

Earth observations are fundamental for investigating the processes driving climate change and thus for supporting decisions on climate change mitigation strategies. Atmospheric remote sounding from space and ground are essential components of this observational strategy. In this context, the Fourier transform infrared spectroscopy (FTIR) programme at the IARC was established with the main goals of long-term monitoring of atmospheric gas composition (ozone related species and greenhouse gases) and the validation of satellite remote sensing measurements and climate models. In particular, within the FTIR programme much effort has been put in developing new strategies for observing tropospheric water vapour isotopologues from ground and space-based remote sensors, since these observations play a fundamental role for investigating the atmospheric water cycle and its links to the global energy and radiation budgets.

The FTIR programme at the IARC is the result of the close and long lasting collaboration of more than a decade between the IARC-AEMET and the [IMK-ASF-KIT](#) (Institute of Meteorology and Climate Research-Atmospheric Trace Gases and Remote Sensing, Karlsruhe Institute of Technology, Germany). The IMK-ASF has operated high resolution ground-based FTS systems for almost two decades and they are leading contributors in developing FTIR inversion algorithms and quality control of FTIR solar measurements. As a result of this collaboration, the FTIR experiment at IZO has contributed to the prestigious international networks NDACC and TCCON since 1999 and 2007, respectively.

7.2 Measurement Programme

A ground-based FTIR experiment for atmospheric composition monitoring has two main components (Figure 7.1): a precise solar tracker that captures the direct solar light beam and couples it into a high resolution interferometer (IFS). IARC's FTIR activities started in 1999 with a Bruker IFS 120M spectrometer, which was replaced by a Bruker IFS 120/5HR spectrometer in 2005 (see technical specifications in Table 7.1).

In order to derive trace gas concentrations from the recorded FTIR solar absorption spectra, synthetic spectra are calculated by the line-by-line radiative transfer model PRFWD (Schneider and Hase, 2009). Then, the synthetic spectra are fitted to the measured ones by the software package PROFFIT (PROFile FIT, Hase et al., 2004).

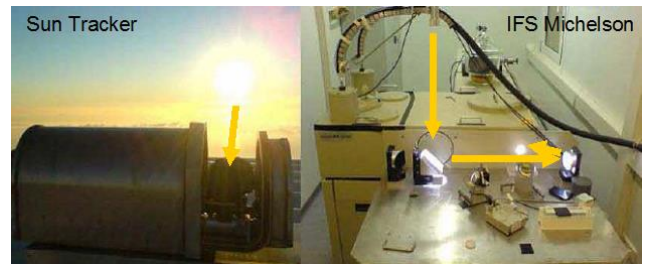

Figure 7.1. The ground-based FTIR experiment at the IARC (scientific container hosting the sun tracker and the Michelson interferometer).

PROFFIT allows to retrieve volume mixing ratio (VMR) profiles and to scale partial or total VMR profiles of several species simultaneously. There have been a lot of efforts for assuring and even further improving the high quality of the FTIR data products: e.g., monitoring the instrumental line shape (Hase et al., 1999), monitoring and improving the accuracy of the applied solar trackers (Gisi et al., 2011), as well as developing sophisticated retrieval algorithms (Hase et al., 2004). The good quality of these long-term ground-based FTIR data sets has been extensively documented by theoretical and empirical validation studies (e.g., Schneider et al., 2008a,b; Schneider et al., 2010; García et al., 2012; Sepúlveda et al., 2012a, 2014a).



Figure 7.2. Picarro L2120-I δD and $\delta 18O$ analyser.

The FTIR programme at the IARC is complemented by two Picarro L2120-I δD and $\delta 18O$ analysers (see Figure 7.2) installed at IZO and TPO within the European project [MUSICA](#).

Table 7.1. Technical Specifications for Bruker IFS 120/5HR (in brackets, if different for 120M).

Manufacturer, Model	Bruker, IFS 120/5HR [IFS 120M]
Spectral range (cm ⁻¹)	700 - 4250 (NDACC) and 3500 - 9000 (TCCON) Optional: 20 - 43000
Apodized spectral resolution (cm ⁻¹)	0.0025 [120M: 0.0035]
Resolution power ($\lambda/\Delta\lambda$)	$2 \cdot 10^5$ at 1000 cm ⁻¹
Typical Scan velocity (cm/s)	2.5 (scan time about 100 s @ 250 cm of Optical Path Difference)
Field of view (°)	0.2
Detectors	MCT and InSb (NDACC); InGaAs (TCCON)
Size (cm)/Weight (kp)/Mobility	320 x 160 x 100 [120M: 200 x 80 x 30] 550 + 70 (Pump) [120M: 100 + 30 (Electronics)] Installed inside container, limited mobility
Quality assurance system	Routine N ₂ O and HCl cell calibrations to determinate the Instrumental Line Shape

These instruments are based on the Wavelength-Scanned Cavity Ring-Down Spectroscopy (WS-CRDS) technology and are calibrated by injecting liquid standards in a Standard Delivery Mode (SDM) from Picarro. The 0.6 Hz-precision of the analyser on δD is $<13.5\%$ at 500 ppmv H₂O and is $<2\%$ for 4000 ppmv. The absolute uncertainty for δD is $<13.7\%$ at 500 ppmv and $<2.3\%$ at 4500 ppmv. The error estimation accounts for instrument precision as well as errors due to the applied data corrections (SDM effects + instrumental drifts $<1\%$, liquid standard bias $<0.7\%$, calibration bias $<0.5\%$) for δD .

7.3 Summary of remarkable results during the period 2012-2014

The FTIR activities from 2012 to 2014 have been focused on the ground and space-based remote sensing FTIR spectrometry as well as in-situ spectrometry.

7.3.1 Ground-based remote sensing FTIR spectrometry

The ground-based FTIR observations have a large potential for monitoring and investigating the composition of the troposphere, the stratosphere and their exchange processes. In order to achieve this, tropospheric signals need to be detected independently from stratospheric signals. This is fundamental to monitor and study, for example, the sources

and sinks of greenhouse gases or the evolution of the ozone layer. For this purpose, our activities have addressed the optimisation, development and validation of the new strategies for monitoring the long-term evolution of trace gases, such as greenhouse gases and ozone, in the framework of NDACC and TCCON networks (see Fig. 7.3).

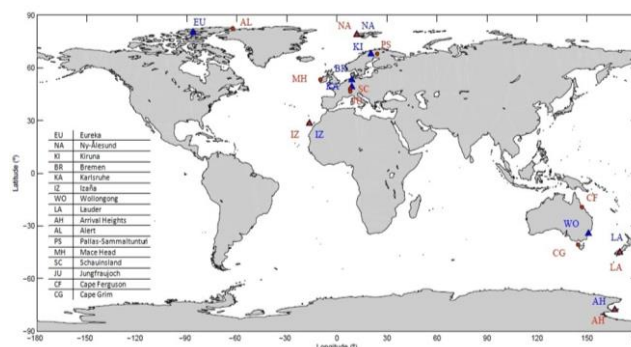

Figure 7.4. Geographical distribution of the FTIR (blue triangles) and GAW stations (red dots) used to develop and validate new strategies for monitoring tropospheric methane (CH₄) concentrations. Reprinted from Sepúlveda et al. (2014a).

We are interested in providing FTIR products with global representativeness (Fig. 7.4), as displayed in Fig. 7.5, where as an example we show that the new tropospheric FTIR methane products can successfully be used to monitor the in situ regional signals at different sites across the globe (Sepúlveda et al., 2012a, 2014a).

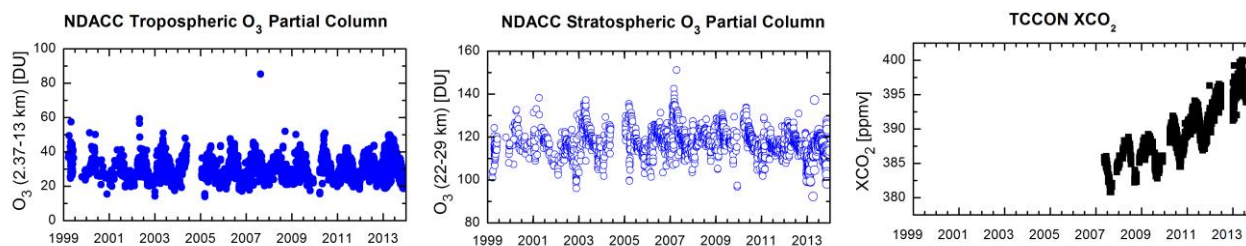

Figure 7.3. Time series of the tropospheric and stratospheric O₃ partial column, and total column-averaged dry air mole fractions of carbon dioxide (XCO₂) as observed by the IARC FTIR in the framework of NDACC and TCCON.

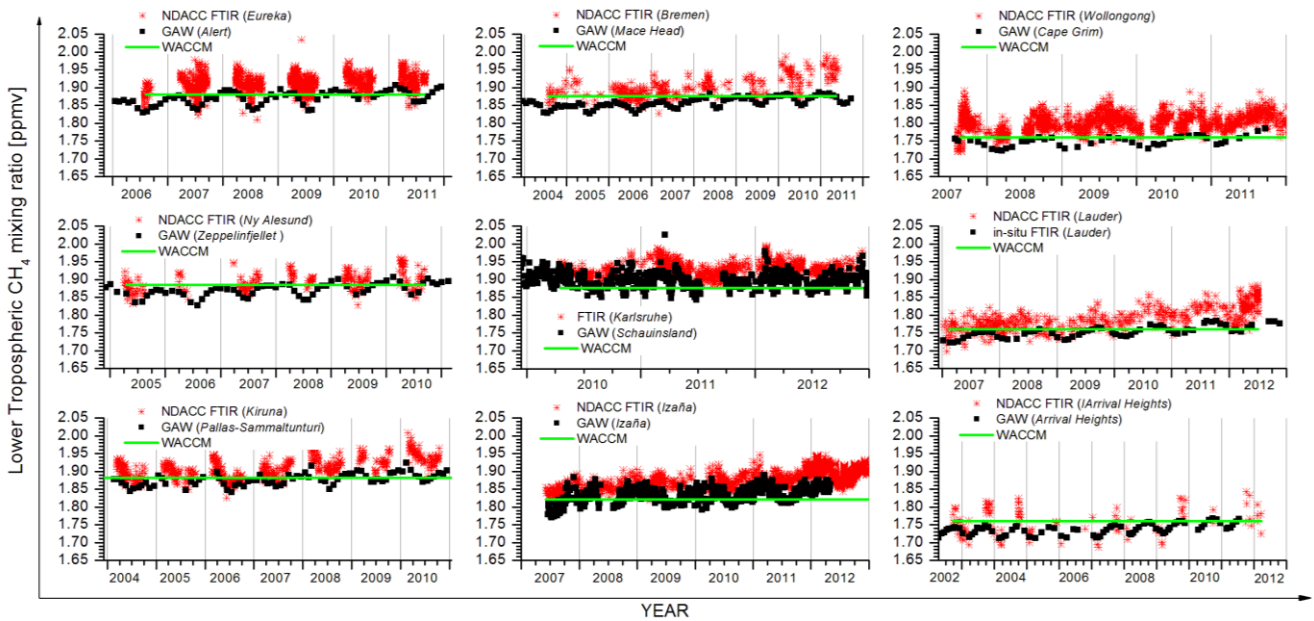

Figure 7.5. Time series of the tropospheric CH₄ concentrations at the FTIR (red squares) and GAW stations (black squares). Reprinted from Sepúlveda et al. (2014a).

These optimisation and validation exercises have also been performed for other important greenhouse gases, such as nitrous dioxide and carbon dioxide (Dohe et al., 2012; Dohe et al., 2014; García et al., 2014a) or for ozone (García et al., 2012, 2014b).

With these refined time series, we have investigated, for example, the long-term changes in the ozone vertical distribution or in the total column amounts, being part of the SI2N Initiative of the Stratosphere-troposphere Processes And their Role in Climate (SPARC) project of the World Climate Research Programme. Our analysis identifies an ozone recovery in the stratosphere in agreement with the WMO (2011; 2014) reports.

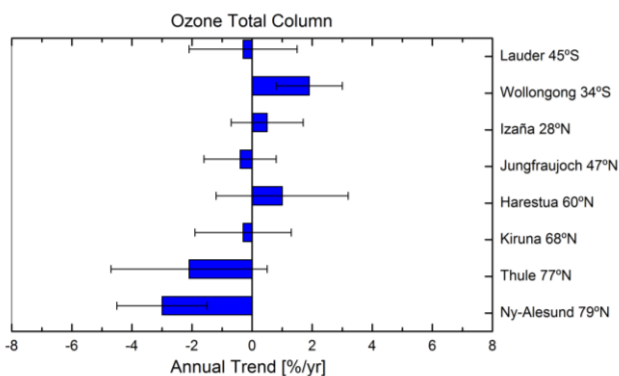

Figure 7.6. Annual trends [in %/yr] of the ozone total column amounts for different FTIR stations covering from 45°S to 79°N. Reprinted from Vigouroux et al. (2014).

However, at least at subtropical latitudes, there is not a clear ozone total column recovery (Fig. 7.6), since the stratospheric ozone increase could be compensated by the tropospheric ozone decrease (García et al., 2012; Vigouroux et al., 2014).

As controlled ozone depleting substances (ODSs) decline, the observed recovery of the stratospheric ozone layer and its long-term evolution largely depend on the greenhouse gases concentrations (WMO, 2014). But, recently, it has been reported that there is an annual increase by up to three % in the stratospheric hydrogen chloride content (main stratospheric chlorine reservoir and tracer of ODSs) over the Northern Hemisphere since 2007 in contrast with the ongoing monotonic decrease of near-surface source gases (Mahieu et al., 2014).

This study, carried out by combining model simulations as well as satellite and ground-based FTIR observations, IZO FTIR among them, attributes this trend anomaly to a slowdown in the Northern Hemisphere atmospheric circulation, not to higher emissions of the precursor substances of the ODSs banned in the Montreal Protocol. This short-term dynamical variability will also affect other stratospheric tracers and needs to be considered when studying the evolution of ozone concentrations in the coming years (Mahieu et al., 2014).

In addition to ozone and greenhouse gases, one key element in the Earth's climate is the water cycle. Remote sensing observations of tropospheric water vapour isotopologue composition can give novel opportunities for understanding the different water cycle processes and their link to the climate. In this context and in the framework of the MUSICA project, the long-term tropospheric water vapour isotopologue observations were initiated at IZO for process-evaluation of tropospheric humidity simulated by general circulation models (Risi et al., 2012a; 2012b). This strategy has extended to ten globally distributed ground-based mid-infrared remote sensing stations of the NDACC (see Fig. 7.4), creating the first long-term tropospheric water vapour

isotopologues database at a global scale (Schneider et al., 2012).

In addition, the ground-based FTIR data allow us to address the validation of new ground-based instrumentations for observing atmospheric gas composition (e.g. water vapour total column) (Sepúlveda et al., 2012b) as well as technical studies on the FTIR technique (inversion algorithms and instrument) (Dohe et al., 2013; García et al., 2014c).

7.3.2 Space-based remote sensing FTIR spectrometry

Within space-based FTIR spectrometry, IARC's high quality FTIR data has been extensively applied for many years for the validation of trace gases measured by different satellite instruments (ILAS, MIPAS, ACE-FTS, GOME). Currently, our activities are focused on the Infrared Atmospheric Sounding Interferometer (IASI) on board MetOp/EUMETSAT satellites through the European projects MUSICA and VALIASI (Validation of the EUMETSAT products of atmospheric trace gases observed from IASI using ground-based Fourier Transform Infrared spectrometry), and the Spanish project NOVIA (Towards a Near Operational Validation of IASI level 2 trace gas products).

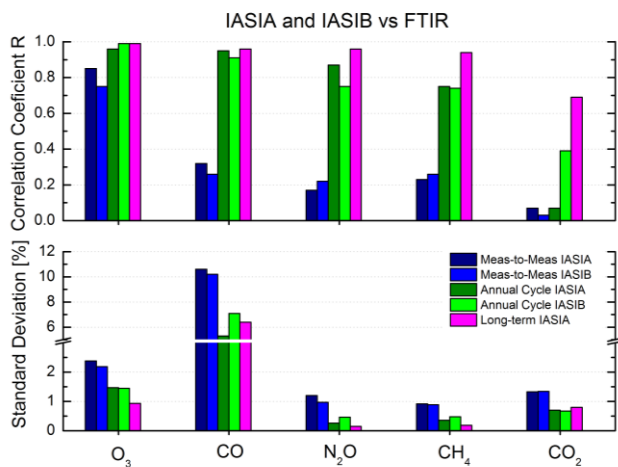

Figure 7.7. Summary of the comparison between IASI/MetOp-A and IASI/MetOp-B versus FTIR at IZO for all the IASI trace gas products at different time scales: measurement-to-measurement (Meas-to-Meas), Annual Cycles and long-term trends.

By means of VALIASI and NOVIA projects, the long-term validation of the IASI operational atmospheric trace gas products (O₃, CO, CO₂, CH₄ and N₂O) is being carried out (García et al., 2013; Kühl et al., 2014; Sepúlveda et al., 2014b, see Fig. 7.7). While MUSICA is focused on the development of new IASI retrievals, their characterization and empirical validation as well as on proof of added value

of IASI tropospheric water vapour isotopologues remote sensing products for investigating different moisture transports (Schneider and Hase, 2011; Schneider et al., 2013; González et al., 2013; Schneider et al., 2014; Wiegele et al., 2014). We also participate in the validation of other space-based remote platforms, like the MIPAS, SCIAMACHY or OCO-II (Blumenstock, et al., 2013; Scheepmaker et al., 2014).

7.3.3 In-situ Spectrometry

The in-situ continuous water vapour measurements recorded at IZO and TPO allow us both to validate the remote sensing water vapour isotopologue observations (IASI and FTIR) (González et al., 2013; Schneider et al., 2014; Wiegele et al., 2014) and to investigate the water supply to the subtropical free troposphere of the subtropical northern Atlantic (González et al., 2014). The latter is briefly documented in Fig. 7.8, which shows isotopologue data obtained by the Picarro in-situ measurements at TPO and uses dust measurements as well as HYSPLIT backward trajectories for classifying the different air mass origins.

The left column (Fig. 7.8) documents the situation for an origin over the northern African landmass (Sahara desert). This origin can clearly be identified by high dust concentrations in the free troposphere, and is also revealed by the respective HYSPLIT backward trajectories for the 5 days before arrival (left column, upper panel and middle panel). An air mass with this history has experienced strong upward transport over Africa without experiencing condensation and the respective {H₂O, δD} pairs (red dots in the bottom panel) are located along a mixing line where boundary layer air can be identified as one mixing end member.

The central and the right columns (Fig. 7.8) show data for clean air (no significant dust concentrations), meaning that there is no link to the African boundary layer. The trajectories until the last condensation point are shown in the upper and middle panels and clearly demonstrate an air mass origin in the free tropospheric northern Atlantic. The bottom panels reveal that the {H₂O, δD} pairs clearly group according to the temperature at the last condensation point. For the last condensation point at higher temperatures, we observe occasionally depletion below the Rayleigh line indicating evaporation of falling rain (for water vapour mixing ratio above 5000 ppmv). Furthermore, we see that mixing along the backward trajectories becomes rather important. In particular, for condensation at low temperatures, we observe weakly depleted dry air, which indicates mixing processes (see bottom panel in right column, Fig. 7.8).

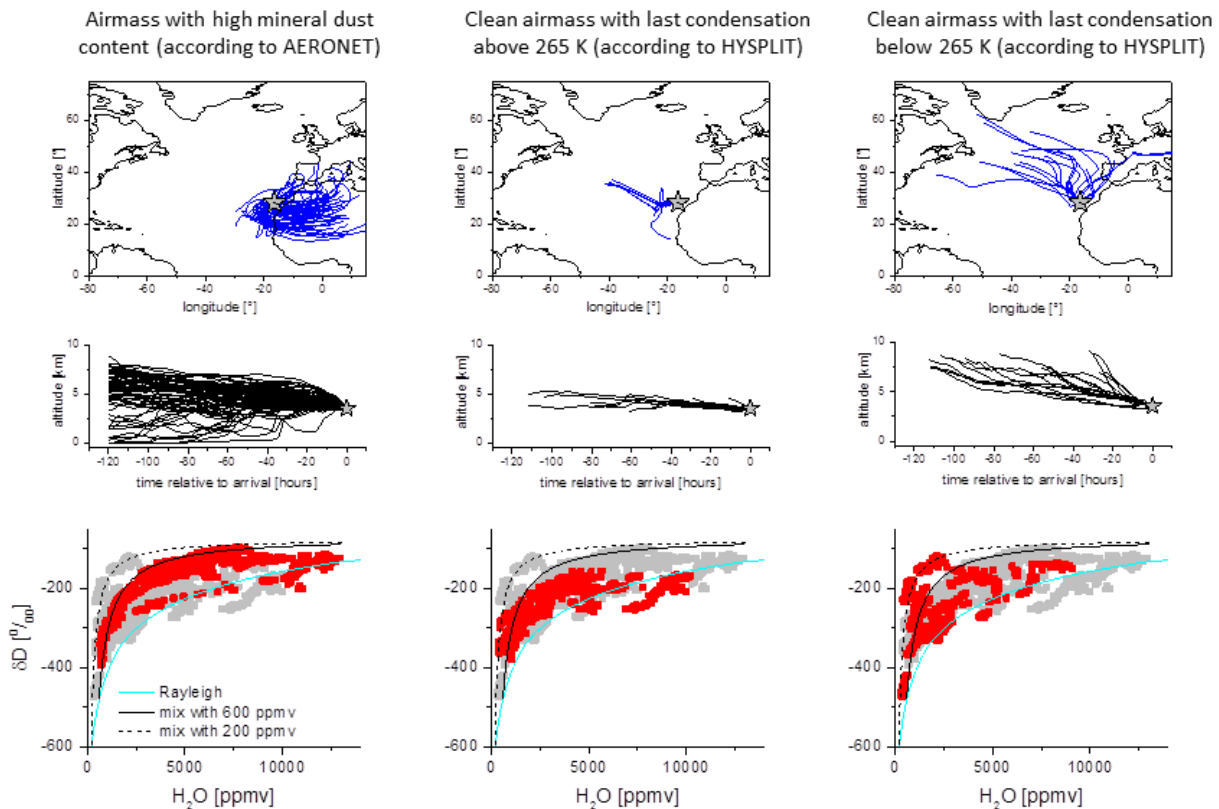

Figure 7.8. Different categories of air masses as detected on Tenerife at 3550 m a.s.l.. Left column: air masses uplifted over the African continent; Central column: no African background and last condensation point below 265 K; Right column: no African background and last condensation point above 265 K. Top row: latitude/longitude during the 5 days before arrival; Middle row: altitude during the 5 days before arrival; Bottom row: $\{H_2O, \delta D\}$ distribution measured by the in-situ Picarro system for the individual category (red dots) and for all categories together (grey dots).

7.4 Participation in Scientific Campaigns

7.4.1 MUSICA/AMISOC aircraft campaign, July 2013

Within the MUSICA project, an aircraft campaign was carried out at the IARC during July 2013. During the campaign, several flights measured in situ water isotopologue profiles between IZO and an altitude of about 8 km. The aircraft measurements were coordinated with the IASI overpasses, so that both the ground-based FTIR and space-based IASI measurements could benefit from the campaign data. The campaign results allow for a comprehensive validation of the space-based IASI and ground-based FTIR profiles and enable us to identify potential systematic errors in the MUSICA data.

7.5 References

Blumenstock, T., Kohlhepp, R., Barthlott, S., García, O. E., Hase, F., Kiefer, M., Raffalski, U., Schneider, M., Investigation of long-term Stability of MIPAS-ENVISAT O₃ and HNO₃ Data using ground-based FTIR Measurements in Kiruna (S) and Izaña (E), ACVE Conference 2013, ESA-ESRIN, Frascati, Italy, 13-15 March, 2013.

Dohe, S., E. Sepúlveda, F. Hase, A. Gómez, M. Schneider, T. Blumenstock and O. García: CO₂ total column amounts at the TCCON sites Izaña (28.3°N, 16.5°W) and Karlsruhe (49.1°N, 8.5°E), International Radiation Symposium, Dahlem Cube, Berlin, Germany, 06-10 August, 2012.

Dohe, S; V. Sherlock; F. Hase; M. Gisi; J. Robinson; E. Sepúlveda, M. Schneider; T. Blumenstock., A method to correct sampling ghosts in historic near-infrared Fourier Transform Spectrometer (FTS) measurements, *Atmos. Meas. Tech.*, 6, 1981-1992, 2013.

Dohe, S., F. Hase, E. Sepúlveda, O.E. García, D. Wunch, P. Wennberg, A. Gómez-Peláez, J.B. Abshire, S.C. Wofsy, M. Schneider, T. Blumenstock; CO₂ profile retrievals from TCCON spectra, *Geophysical Research Abstracts*, 16, EGU2014-14952-1, 2014.

García, O. E., Schneider, M., Redondas, A., González, Y., Hase, F., Blumenstock, T., and Sepúlveda, E.: Investigating the long-term evolution of subtropical ozone profiles applying ground-based FTIR spectrometry, *Atmos. Meas. Tech.*, 5, 2917-2931, doi:10.5194/amt-5-2917-2012, 2012.

García, O.E., M. Schneider, F. Hase, T. Blumenstock, E. Sepúlveda and A. Gómez-Peláez, Validation of the IASI operational CH₄ and N₂O products using ground-based Fourier Transform Spectrometer: Preliminary results at the Izaña Observatory (28°N, 17°W), *Annals of Geophysics, Fast Track-1*, 10.4401/ag-6326, 2013.

García, O.E., M. Schneider, F. Hase, T. Blumenstock, E. Sepúlveda, A. Gómez-Peláez, S. Barthlott, S. Dohe, Y.

- González, F. Meinhardt and M. Steinbacher, Monitoring of N₂O by ground-based FTIR: optimisation of retrieval strategies and comparison to GAW insitu observations IRWG, NDACC-IRWG/TCCON meeting 2014, 12-16 May, Bad Sulza (Germany), 2014a.
- García, O.E., Schneider, M., Hase, F., Blumenstock, T., Sepúlveda, E., and González, Y.: Quality assessment of ozone total column amounts as monitored by ground-based solar absorption spectrometry in the near infrared (>3000 cm⁻¹), *Atmos. Meas. Tech.*, 7, 3071-3084, doi:10.5194/amt-7-3071-2014, 2014b.
- García, O.E., M. Schneider, F. Hase, T. Blumenstock, E. Sepúlveda, E. Cuevas, A. Redondas, A. Gómez-Peláez and J.J. Bustos, Effect of updates in LINEFTIT and PROFFIT at Izaña ground-based FTIR: improvement of the ILS characterisation and intra-day pressure and temperature variability, NDACC-IRWG/TCCON meeting 2014, 12-16 May, Bad Sulza (Germany), 2014c.
- Gisi, M., F. Hase, S. Dohe, and T. Blumenstock: Camtracker: a new camera controlled high precision solar tracker system for FTIR-spectrometers, *Atmos. Meas. Tech.*, 4, 47-54, 2011.
- González, Y., Schneider, M., Christner, E., Rodríguez, O.E., Sepúlveda, E., Christoph Dyroff, C., and Wiegeler, A., First observations of tropospheric data observed by ground- and space-based remote sensing and surface in-situ measurement techniques at MUSICA's principle reference station (Izaña Observatory, Spain), European Geosciences Union General Assembly (EGU)-2013, 7-12 April 2013, Vienna, Austria, 2013.
- González, Y., Schneider, M., Rodríguez, S., Cuevas, E., Dyroff, C., Christner, E., Andrey, J., García, O., Sepúlveda, E.: Measurements and interpretation of the water vapor δD variability at Izaña North Atlantic free troposphere site, Symposium on Atmospheric Chemistry and Physics at Mountain Sites, August 11-15, Steamboat Springs, CO, USA, 2014.
- Hase, F., T. Blumenstock, C. Paton-Walsh: Analysis of the instrumental line shape of high-resolution Fourier transform IR spectrometers with gas cell measurements and new retrieval software, *Appl. Opt.* 38, 3417-3422, 1999.
- Hase, F., J.W. Hannigan, M.T. Coffey, A. Goldman, M. Höpfner, N.B. Jones, C.P. Rinsland, S.W. Wood: Intercomparison of retrieval codes used for the analysis of high-resolution, ground-based FTIR measurements, *Journal of Quantitative Spectroscopy & Radiative Transfer* 87, 25-52, 2004.
- Kerzenmacher, T., Dils, B., Kumps, N., Blumenstock, T., Clerbaux, C., Coheur, P.-F., Demoulin, P., García, O., George, M., Griffith, D. W. T., Hase, F., Hadji-Lazarou, J., Hurtmans, D., Jones, N., Mahieu, E., Notholt, J., Paton-Walsh, C., Raffalski, U., Ridder, T., Schneider, M., Servais, C., and De Mazière, M.: Validation of IASI FORLI carbon monoxide retrievals using FTIR data from NDACC, *Atmos. Meas. Tech.*, 5, 2751-2761, doi:10.5194/amt-5-2751-2012, 2012.
- Kühl, S., O. García, A. Gómez Peláez, A. Redondas, P.M. Campos, E. Sepúlveda, M. Schneider, A. Wiegeler, S. Dohe, S. Barthlott, F. Hase and T. Blumenstock, VALIASI - Validation of IASI level 2 products by GB-FTIR measurements, NDACC-IRWG/TCCON meeting 2014, 12-16 May, Bad Sulza (Germany), 2014.
- Mahieu, E., M.P. Chipperfield, J. Notholt, T. Reddman, J. Anderson, P.F. Bernath, T. Blumenstock, M.T. Coffey, S. Dhomse, W. Feng, B. Franco, L. Froidevaux, D.W.T. Griffith, J. Hannigan, F. Hase, R. Hossaini, N.B. Jones, I. Morino, I. Murata, H. Nakajima, M. Palm, C. Paton-Walsh, J.M. Russell III, M. Schneider, C. Servais, D. Smale, K.A. Walker: Recent northern hemisphere hydrogen chloride increase due to atmospheric circulation change, *Nature*, DOI: 10.1038/nature13857, 2014.
- Risi, C., Noone, D., Worden, J. Frankenberg, C., Stiller, G., Kiefer, M., Funke, B., Walker, K., Bernath, P., Schneider, M., Wunch, D., Sherlock, V., Deutscher, N., Griffith, D., Wennberg, P.O., Strong, K., Smale, D., Mahieu, E., Barthlott, S. Hase, F., García, O., Notholt, J., Warneke, T., Toon, G., Sayres, D., Bony, S., Lee, J., Brown, D., Uemura, R., y Sturm, C.: Process-evaluation of tropospheric humidity simulated by general circulation models using water vapor isotopologues: 1. Comparison between models and observations, *J. Geophys. Res.*, 117, D05303, doi:10.1029/2011JD016621, 2012a.
- Risi, C., Noone, D., Worden, J. Frankenberg, C., Stiller, G., Kiefer, M., Funke, B., Walker, K., Bernath, P., Schneider, M., Bony, S., Lee, J., Brown, D. and Sturm, C.: Process-evaluation of tropospheric humidity simulated by general circulation models using water vapor isotopic observations: 2. Using isotopic diagnostics to understand the mid and upper tropospheric moist bias in the tropics and subtropics, *J. Geophys. Res.*, 117, D05304, doi:10.1029/2011JD016623, 2012b.
- Scheepmaker, R. A., Frankenberg, C., Deutscher, N. M., Schneider, M., Barthlott, S., Blumenstock, T., Garcia, O. E., Hase, F., Jones, N., Mahieu, E., Notholt, J., Velasco, V., Landgraf, J., and Aben, I.: Validation of SCIAMACHY HDO/H₂O measurements using the TCCON and NDACC-MUSICA networks, *Atmos. Meas. Tech. Discuss.*, 7, 11799-11851, doi:10.5194/amtd-7-11799-2014, 2014.
- Schneider, M., F. Hase, T. Blumenstock, A. Redondas, and E. Cuevas: Quality assessment of O₃ profiles measured by a state-of-the-art ground-based FTIR observing system, *Atmos. Chem. Phys.*, 8, 5579-5588, 2008a.
- Schneider, M., A. Redondas, F. Hase, C. Guirado, T. Blumenstock, and E. Cuevas: Comparison of ground-based Brewer and FTIR total O₃ monitoring techniques, *Atmos. Chem. Phys.*, 8, 5535-5550, 2008b.
- Schneider, M. and Hase, F.: Improving spectroscopic line parameters by means of atmospheric spectra: Theory and example for water vapour and solar absorption spectra, *J. Quant. Spectrosc. Radiat. Transfer*, 110, 1825-1839, doi:10.1016/j.jqsrt.2009.04.011, 2009.
- Schneider, M., P. M. Romero, F. Hase, T. Blumenstock, E. Cuevas, and R. Ramos: Continuous quality assessment of atmospheric water vapour measurement techniques: FTIR, Cimel, MFRSR, GPS, and Vaisala RS92, *Atmos. Meas. Tech.*, 3, 323-338, 2010.
- Schneider, M., Barthlott, S., Hase, F., González, Y., Yoshimura, K., García, O. E., Sepúlveda, E., Gomez-Pelaez, A., Gisi, M., Kohlhepp, R., Dohe, S., Blumenstock, T., Wiegeler, A., Christner, E., Strong, K., Weaver, D., Palm, M., Deutscher, N. M., Warneke, T., Notholt, J., Lejeune, B., Demoulin, P., Jones, N., Griffith, D. W. T., Smale, D., and Robinson, J.: Ground-based remote sensing of tropospheric water vapour isotopologues within the project MUSICA, *Atmos. Meas. Tech.*, 5, 3007-3027, doi:10.5194/amt-5-3007-2012, 2012.
- Schneider, M., Wiegeler, A., Hase, F., Barthlott, S., Blumenstock, T., García, O.E., Sepúlveda, E., IASI/METOP retrievals within the project MUSICA, IASI Conference 2013, Hyères, France, 4-8 February, 2013.
- Schneider, M., González, Y., Dyroff, C., Christner, E., Wiegeler, A., Barthlott, S., García, O. E., Sepúlveda, E., Hase, F., Andrey, J., Blumenstock, T., Guirado, C., Ramos, R., and Rodríguez, S.:

- Empirical validation and proof of added value of MUSICA's tropospheric δD remote sensing products, *Atmos. Meas. Tech. Discuss.*, 7, 6917-6969, doi:10.5194/amtd-7-6917-2014, 2014.
- Sepúlveda, E., Schneider, M., Hase, F., García, O. E., Gomez-Pelaez, A., Dohe, S., Blumenstock, T., and Guerra, J. C.: Long-term validation of total and tropospheric column-averaged CH_4 mole fractions obtained by mid-infrared ground-based FTIR spectrometry, *Atmos. Meas. Tech.*, 5, 1425-1441, doi:10.5194/amt-5-1425-2012, 2012a.
- Sepúlveda, E., M. Schneider, F. Hase, O.E. García, M. Gisi, T. Blumenstock, S. Dohe, Y. Gonzalez, and J.C. Guerra: Compact and low resolution spectrometer for the inversion of water vapour total column amounts, International Radiation Symposium, Dahlem Cube, Berlin, Germany, 06-10 August, 2012b.
- Sepúlveda, E., Schneider, M., Hase, F., Barthlott, S., Dubravica, D., García, O. E., Gomez-Pelaez, A., González, Y., Guerra, J. C., Gisi, M., Kohlhepp, R., Dohe, S., Blumenstock, T., Strong, K., Weaver, D., Palm, M., Sadeghi, A., Deutscher, N. M., Warneke, T., Notholt, J., Jones, N., Griffith, D. W. T., Smale, D., Brailsford, G. W., Robinson, J., Meinhardt, F., Steinbacher, M., Aalto, T., and Worthy, D.: Tropospheric CH_4 signals as observed by NDACC FTIR at globally distributed sites and comparison to GAW surface in-situ measurements, *Atmos. Meas. Tech.*, 7, 2337-2360, doi:10.5194/amt-7-2337-2014, 2014a.
- Sepúlveda, E., O. García, M. Schneider, F. Hase, T. Blumenstock, S. Kühl, A. Gómez-Peláez, P. M. Romero-Campos and Y. González, Consistency between IASI-A and IASI-B operational trace gas products in the Subtropical North Atlantic Region. Comparison to ground-based FTIR at the Izaña Observatory, EUMETSAT Conference 2014, 22-26 September, Geneva, Switzerland, 2014b.
- Vigouroux, C., Blumenstock, T., Coffey, M., Errera, Q., García, O., Jones, N. B., Hannigan, J. W., Hase, F., Liley, B., Mahieu, E., Mellqvist, J., Notholt, J., Palm, M., Persson, G., Schneider, M., Servais, C., Smale, D., Thölix, L., and De Mazière, M.: Trends of ozone total columns and vertical distribution from FTIR observations at 8 NDACC stations around the globe, *Atmos. Chem. Phys. Discuss.*, 14, 24623-24666, doi:10.5194/acpd-14-24623-2014, 2014.
- Wiegele, A., Schneider, M., Hase, F., Barthlott, S., García, O. E., Sepúlveda, E., González, Y., Blumenstock, T., Raffalski, U., Gisi, M., and Kohlhepp, R.: The MUSICA MetOp/IASI H_2O and δD products: characterisation and long-term comparison to NDACC/FTIR data, *Atmos. Meas. Tech.*, 7, 2719-2732, doi:10.5194/amt-7-2719-2014, 2014.
- WMO (World Meteorological Organization), Scientific Assessment of Ozone Depletion: 2010, Global Ozone Research and Monitoring Project-Report No. 52, 516 pp., Geneva, Switzerland, 2011.
- WMO (World Meteorological Organization), Assessment for Decision Makers of the Scientific Assessment of Ozone Depletion: 2014, Geneva, Switzerland, 2014.

7.6 Staff and collaborators

The FTIR research group (listed below) is composed of researchers and specialist technicians from the IARC-AEMET, from IMK-ASF-KIT, and from ULL:

- Dr Omaira García (AEMET; Head of programme)
- Dr Yenny González (AEMET; Research Scientist)
- Dr Eliezer Sepúlveda (AEMET/ULL; Research Scientist)
- Dr M Esther Sanroma Ramos (AEMET; Research Scientist)
- Ramón Ramos (AEMET; Head of Infrastructure)
- Dr Sven Kühl (AEMET; Research Scientist)
- Dr Matthias Schneider (IMK-ASF-KIT; Head of the MUSICA group)
- Dr Thomas Blumenstock (IMK-ASF-KIT; Head of Ground-based remote-sensing using Fourier-transform interferometers (BOD) group)
- Dr Frank Hase (IMK-ASF-KIT; Research Scientist, BOD group)
- Dr Andreas Wiegele (IMK-ASF-KIT; Research Scientist, MUSICA group)

8 In situ Aerosols

8.1 Main Scientific Goals

Atmospheric aerosol is constituted by a mixing of natural (e.g. sea salt, desert dust or biogenic material) and anthropogenic (e.g. soot, industrial sulphate, nitrate, metals or combustion linked carbonaceous matter) airborne particles whose size range from a few nanometre (nm) to tens of microns (μm). Aerosols impair air quality with impacts on human health due to cardiovascular, cerebrovascular and chronic respiratory diseases; they also influence climate by scattering and absorbing radiation and by influencing cloud formation and rainfall.

The activities of the In situ Aerosols programme are developed within the scientific priorities of the Global Atmosphere Watch programme. One of the main tasks of our group is to maintain the long-term observations of aerosols at IZO. These measurements improve the understanding of the potential long-term multi-decadal changes and trends of aerosols in the subtropical North Atlantic. Our investigations are focused on: 1) Long-term multi-decadal variability and trends of aerosols; 2) Aerosols and climate and 3) Aerosols and air quality.

8.2 Measurement Programme

At IZO, instruments for aerosols measurements are located in the so-called Particles Laboratory (PARTILAB) (Fig. 8.1). The laboratory is equipped with a whole air inlet for conducting the aerosol sample to the on-line analysers (CPCs, SMPS, APS, MAAP, aethalometer, nephelometer) and two additional PM_{10} and $\text{PM}_{2.5}$ inlets for the aerosol samplers (Fig. 8.2 and Fig. 8.3). The interior of the PARTILAB is maintained at 22 °C. Because of the low relative humidity (RH) in the outdoor ambient air (RH percentiles 25th, 50th and 75th are 15%, 31% and 55%, respectively) driers are not needed. Measurements of number concentration, size distributions and optical properties of aerosols are performed with high time resolution (Table 3.2).



Figure 8.1. PARTILAB at Izaña Atmospheric Observatory.

For these automatic instruments, the QA/QC activities include:

- <daily checks> of the data and status of the instruments.
- <weekly checks> of the airflows and leak tests for some instruments (e.g. SMPS).
- <quarterly checks> which includes measurements of the instrumental zero (24h filtered air) for all the instruments (CPCs, SMPS, APS, MAAP, aethalometer nephelometer) and calibration checks (e.g. nephelometer).
- <annual intercomparisons> for some instruments.
- participation in intercomparisons, e.g. those performed annually between 2010 and 2012 for CPCs and SPMS at El Arenosillo - Huelva (Gómez-Moreno et al., 2011, 2013) and those in the World Calibration Centre for Aerosols Physics in Leipzig – Germany for CPCs (Sep 2012) and absorption photometers (Nov 2005; Müller et al., 2011).

The procedure for these activities follows the recommendation of the GAW programme for aerosols.

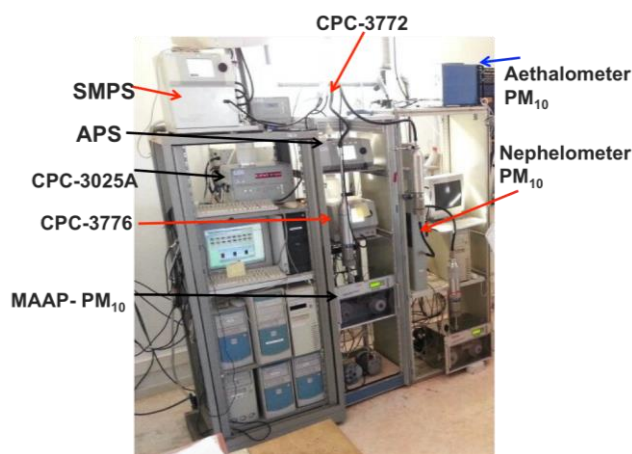

Figure 8.2. Image of on-line analysers inside the PARTILAB.



Figure 8.3. PM_{10} and $\text{PM}_{2.5}$ samplers inside the PARTILAB.

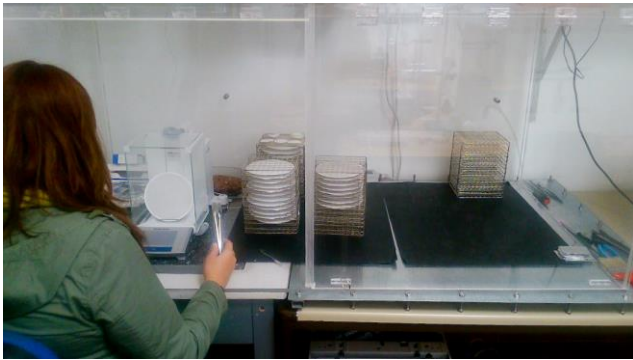

Figure 8.4. IARC Aerosol Filters laboratory.

The aerosols chemical composition programme is based on:

- the collection of aerosol samples on filters. Samples are collected at night to avoid the diurnal upslope winds that may bring material from the boundary layer,
- the determination of the aerosol mass concentrations by the gravimetric method. Filters are weighed, before and after sampling, at 20 °C temperature and 30-35 % relative humidity in the Aerosol Filters Laboratory (Fig. 8.4) of the Izaña Atmospheric Research Centre (see Section 3.2.1). The weighing filters procedure used is similar to that described in EN-14907, except that we use a lower relative humidity (30-35 %) due to the relative humidity of the ambient air at IZO being much lower than the 50% stated by EN-14907.
- The determination of chemical composition which currently includes elemental composition (those detected by IPC-AES, i.e. Al, Ca, Fe, Mg, K, Na,...),

salts (SO_4^{2-} , NO_3^- , NH_4^+ , Cl^-), organic carbon, elemental carbon and trace elements (those detected by IPC-MS, i.e. P, V, Ni, Cd, As, Sb, Sn,...).

The QA/QC procedure for the aerosol chemical composition programme includes:

- airflow checks and calibrations.
- the collection of blank field filters for gravimetry and chemical analysis.
- intercomparison exercises (Fig. 8.5).

For the QA/QC activities, the group is equipped with four bubble flow-meter Gilibrators™ for measuring airflows from a few to tens of litres per minute (e.g. CPCs, SMPS, APS, MAAP, aethalometer nephelometer) and three pressure drop flow-meters for measuring airflows of tens of cubic metres per hour (e.g. samplers).

The World Calibration Centre for Aerosol Physics audited the IZO aerosol programme in Nov 2006 (Tuch and Nowak, 2006). An updated report dated March 2014 is available (Rodríguez et al., 2014a).

The studies on aerosols and air quality have mostly been performed in the city of Santa Cruz de Tenerife, where the In situ Aerosols group managed an aerosol programme that included measurements of chemical composition, black carbon and particle number concentration during five years within the framework of the project EPAU funded by the Spanish Ministry of Environment using methods similar to those described for IZO in Table 3.2.

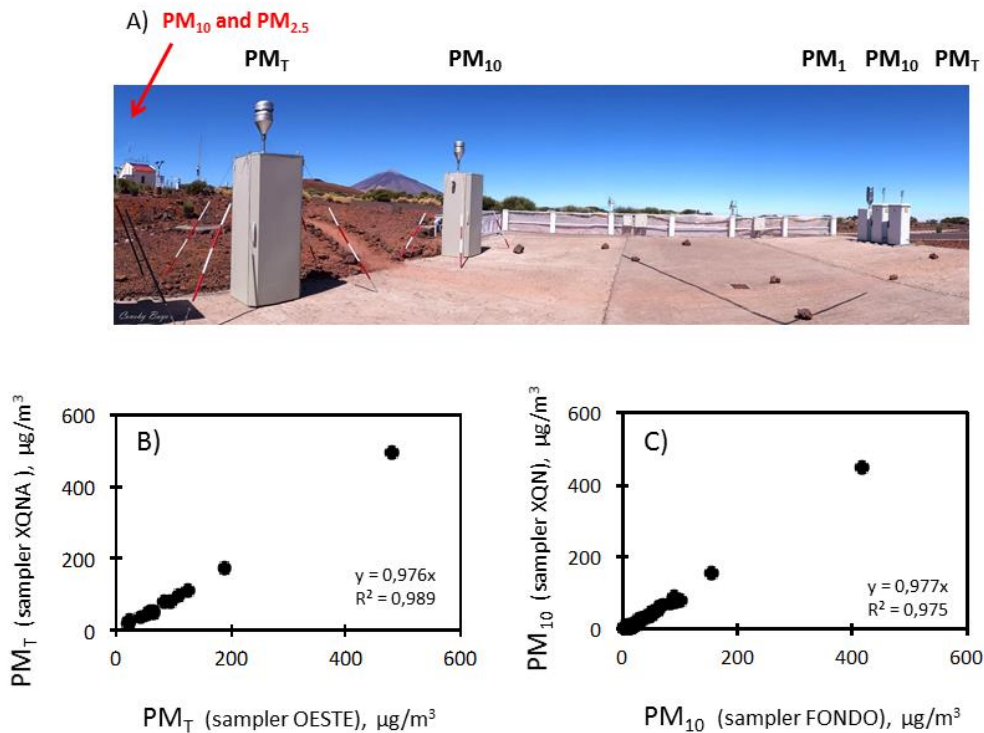

Figure 8.5. Intercomparison between PMx samplers in August 2013, PM_T: total particulate matter, PM₁₀: particulate matter with an aerodynamic diameter < 10 μm , PM₁: particulate matter with an aerodynamic diameter < 1 μm .

8.3 Summary of remarkable results during the period 2012-2014

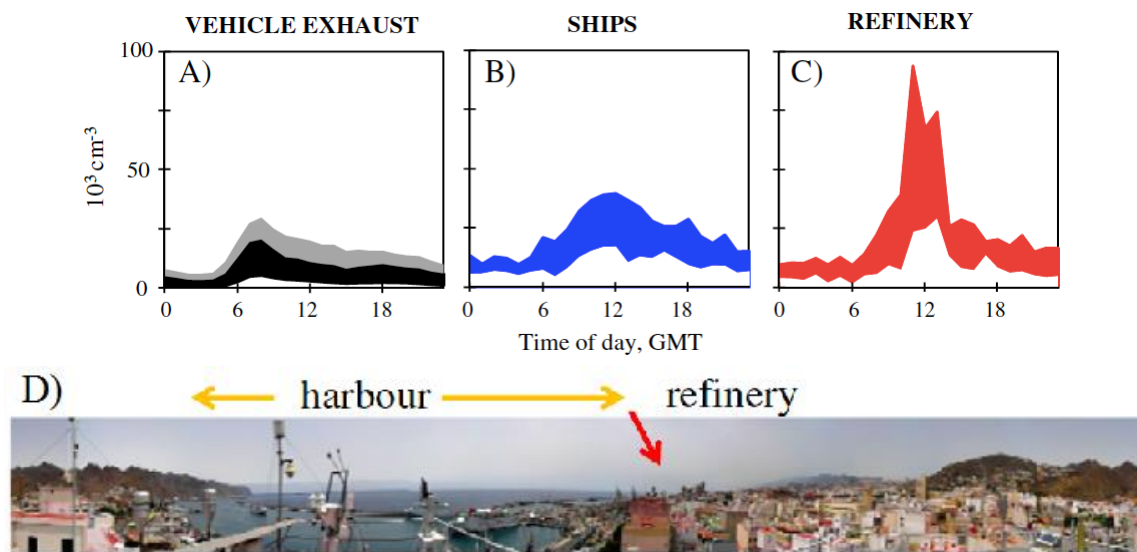

Figure 8.6. A-C) Daily evolution (hourly values) of the ultrafine particles concentration in the ambient air of Santa Cruz de Tenerife city linked to each source. Lower and upper border of the shadowed area represent the 25th and 75th percentiles. D) View of Santa Cruz de Tenerife from SCO. Reprinted from González and Rodríguez (2013).

During 2012 to 2014, the In situ Aerosols group focused research activities on ultrafine particles and air quality. Measurement protocols and accuracy in the measurements of ultrafine particles were assessed and discussed in ACTRIS and REDMAAS projects. Our studies in the cities of Santa Cruz de Tenerife, Huelva and Barcelona identified new sources of ultrafine particles. High concentrations of ultrafine particles, sulphur dioxide and toxic metals in the ambient urban air were linked to the emissions of ships and some industries, whose emissions may result in concentrations higher than those prompted by vehicle exhausts (Dall'Osto et al., 2012; González and Rodríguez, 2013; Fernández-Camacho et al., 2013; Fig. 8.6). Research involving both the Canarian University Hospital and the In situ Aerosols group found that the exposure to these pollutants in the ambient air have implications for cardiovascular diseases (Domínguez-Rodríguez et al., 2011, 2013a, 2013b, 2013c).

The In situ Aerosols group also participated in a joint study with the University of Huelva and NOAA Air Resources Laboratory to simulate chemically speciated $\text{PM}_{2.5}$ (sulphate, ammonium, nitrate, elemental and organic carbon) using high resolution (1 hour, 2 km x 2 km) air quality modelling in south-west Europe (Fig. 8.7). We developed and implemented a high resolution emission inventory of both anthropogenic and biogenic emissions for the study area, and utilized a high resolution meteorological model (MM5) to provide the meteorological input fields for three nested domains. The simulations were evaluated

against chemically speciated observation data at urban and rural sites. The results demonstrated the important role of non-ammonium nitrate and sulphate in southern Europe and identified scenarios of pollution events influencing air quality in this region (Milford et al., 2013).

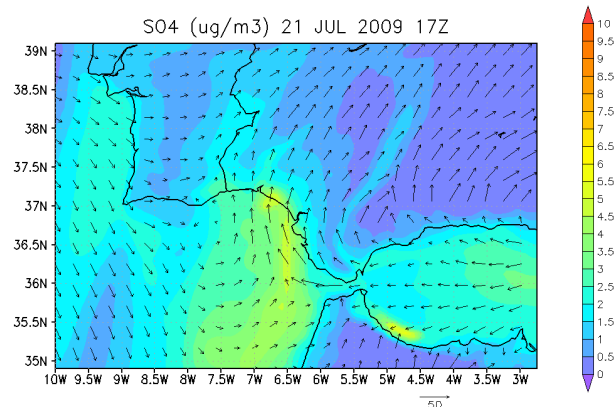

Figure 8.7. Simulated surface $\text{PM}_{2.5}$ sulphate concentration and wind vectors for 21/7/2009 17 UTC for domain 2 (south-west Spain and southern Portugal). Reprinted from Milford et al. (2013).

In addition, we use MM5 and the Hybrid Single Particle Lagrangian Integrated Trajectory (HYSPPLIT) dispersion model to simulate concentrations of heavy metals and metalloids in atmospheric aerosols from industrial emissions in the Huelva and Algeciras Bay (Gibraltar Strait) area.

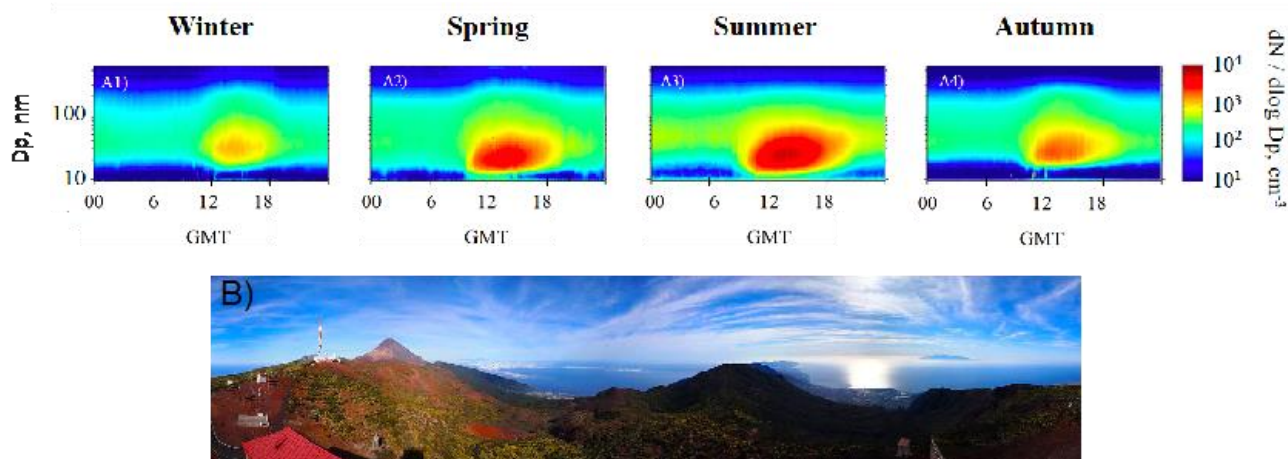

Figure 8.8. A1-A4) Hourly mean values of aerosol size distributions at Izaña Atmospheric Observatory averaged by seasons as illustration of the ultrafine particles growth. B) View from Izaña Atmospheric Observatory. Reprinted from García et al. (2014).

Ultrafine particles are not only formed close to sources. A climatology study based on the long-term records at IZO evidenced that formation of new ultrafine particles is frequent in the upslope winds that bring air from the boundary layer to mountain tops, even if sources are distant (García et al., 2014). The formation of new ultrafine particles and their growth to tens of nanometres diameter is more frequently observed in spring and summer (Fig. 8.8). We found that the inter-annual variability (2008-2012) in the frequency of these new particle formation events is correlated with sulphur dioxide concentrations in the upslope winds, which indicates that a decrease in the emissions rates of this aerosol precursor could decrease the impacts of ultrafine particle pollution also at sites distant to the SO₂ source.

Within the framework of the project POLLINDUST, the In Situ Aerosols group also studied the long-term variability of Saharan dust export to the North Atlantic. Data of aerosol dust concentrations measured within the framework of different research projects at IZO throughout 27 years were compiled and analysed. These aerosol dust records at IZO, starting in 1987 (Fig. 8.9), are (Rodríguez et al., 2012): i) the fourth longest in the world (after Barbados-1965, Miami-1972 and American Samoa-1982), ii) the longest in the free troposphere, and iii) the longest including several sizes (total, sub-10 µm and sub-2.5 µm). We found that the observed large inter-annual variability in Saharan dust export in summer is modulated by the variability in the trade winds intensity at the north of the Inter-tropical Convergence Zone in North Africa (Rodríguez et al., 2014).

These long-term records are crucial for understudying the implications of the supply of Fe – dust to the ocean on the ocean-atmosphere CO₂ exchange. The In situ Aerosols group participated in the workshop organized by the United Nations - Group of Experts on the Scientific Aspects of Marine Environmental Protection (UN-GESAMP) and the WMO Sand and Dust Storm Warning and Advisory System

(WMO-SDS) held in Malta 7-9 March 2011 for discussing the research activities needed for understanding the links between dust deposition, CO₂ modulation and climate. The deliberations of that workshop are discussed in the review paper by Schulz et al. (2012; Fig. 8.10).

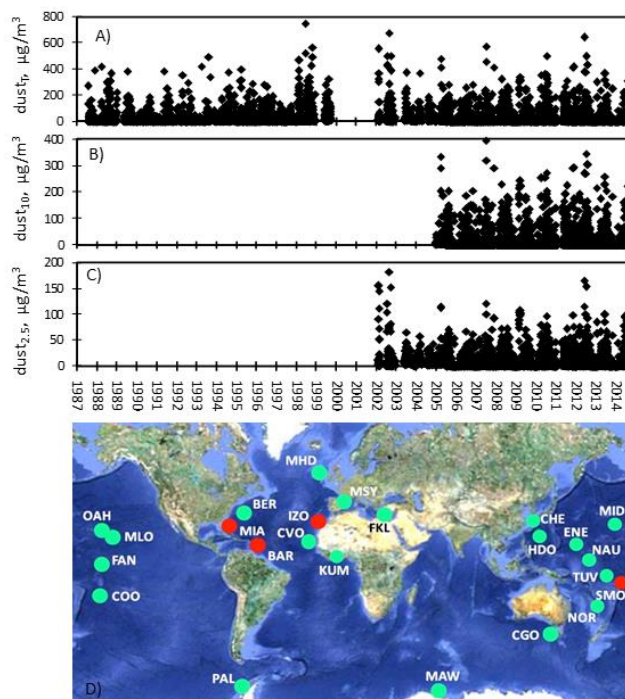

Figure 8.9. Time series of A) Total dust, B) dust₁₀ and C) dust_{2.5} concentration at Izaña Atmospheric Observatory, 1987-2014. D) Atmospheric remote observatories where long term in situ measurements of aerosol dust have been performed during at least 4 years (green circle) and during at least the last two decades (red circle). Reprinted from Rodríguez et al. (2012).

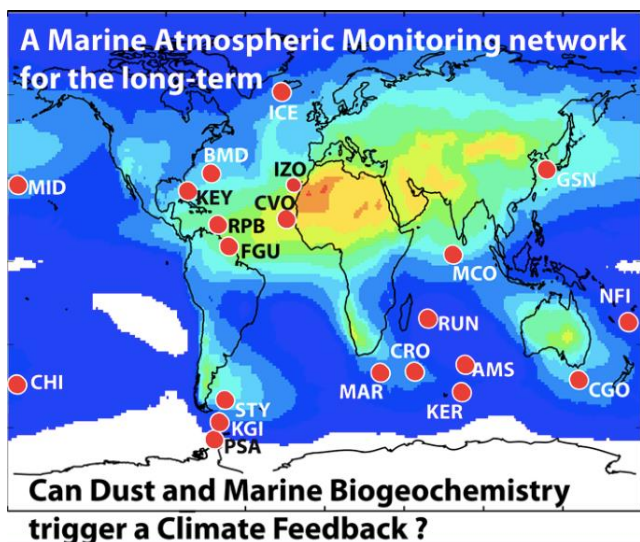

Figure 8.10. Sites proposed for long-term marine atmospheric measurements. AMS: Amsterdam, BMD: Bermuda, CGO: Cape Grim, CHI: Chatham, CRO: Crozet, CVO: Cape Verde, FGU: French Guyana, GSN: Gosan, ICE: Iceland, KER: Kerguelen, KEY: Miami, KGI: King George, MAR: Marion, MCO: Maldives, MID: Midway, NFI: Norfolk, IZO: Izaña, RPB: Barbados, PSA: Palmer, RUN: La Réunion, STY: Falkand Islands. Reprinted from Shultz et al. (2012).

Influence of dust on the Earth System depends on microphysical properties of the aerosol dust particles. Measurements of size segregated elemental composition of dust have been performed in summertime (August 2010) in collaboration with the LABEC - Sezione di Firenze Istituto Nazionale di Fisica Nucleare (F. Lucarelli and S. Nava), by Particle-Induced X ray Emission (PIXE) techniques. These measurements have allowed us to study short (down to hourly) and long-term variability in the composition of Saharan dust by combining a set of additional instruments

such as cascade impactors (50 nm to 20 μm) and streakers (total, coarse 2.5-10 μm and sub-2.5 μm ; Fig. 8.11).

8.4 Participation in Scientific Campaigns

The objective of the Cloud, Aerosols and Ice Measurements in the Saharan Air Layer (CALIMA) campaigns in summer 2013 and 2014 was to measure the ability of Saharan dust particles to act as nuclei for ice and cloud droplets. This field measurement campaign was performed at IZO by scientists of the Institute for Atmospheric and Climate Science of Zürich (B. Sierau, Y. Boose, L. Lacher and F. Mahr), the Max Planck Institute for Chemistry (S. Schimdt) and the In situ Aerosols group. Additional aerosol measurements included ice nuclei concentration, cloud condensation nuclei concentration and activation parameters and mass spectrometer measurements of chemical composition, size distribution and mixing state of single particles (Fig. 8.12).



Figure 8.12. Instrumentation used during the CALIMA campaign.

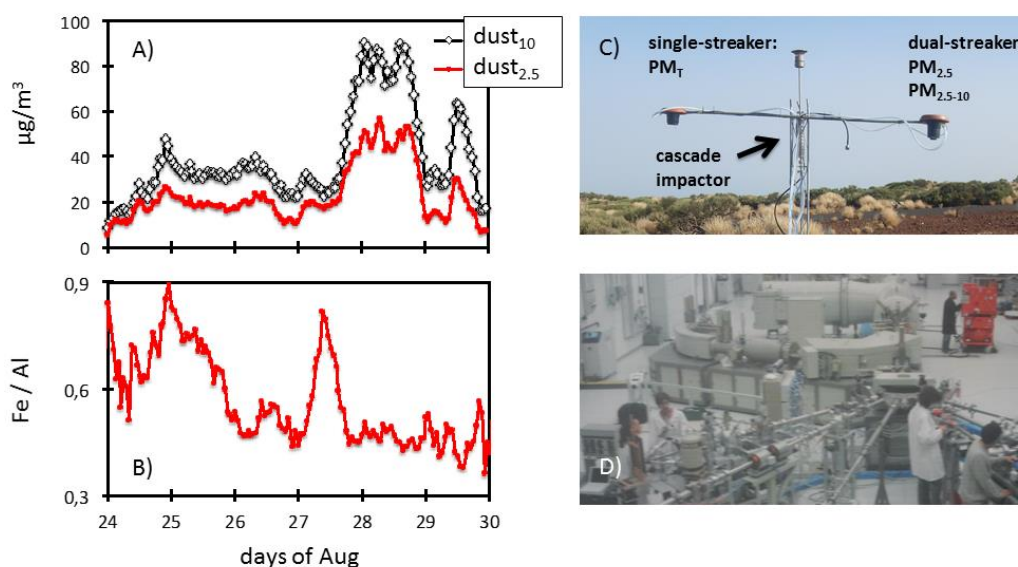

Figure 8.11 A) Time series of dust in the size fractions smaller than 10 and 2.5 microns (μm) and B) ratio Fe / Al obtained in samples collected at Izaña Atmospheric Observatory with a streaker (C) in August 2010 and analysed by D) PIXE at the LABEC-INFN (Firenze, Italy).

8.5 References

- Dall'Osto, M. D.C.S. Beddows, J. Pey, S. Rodriguez, A. Alastuey, R. M. Harrison, X. Querol. Urban aerosol size distributions over the Mediterranean city of Barcelona, NE Spain. *Atmospheric Chemistry and Physics*, 12, 10693-10707, 2012. DOI: doi:10.5194/acp-12-10693-2012.
- Fernández-Camacho, R., S. Rodríguez, J. de la Rosa, A.M. Sánchez de la Campa, A. Alastuey, X. Querol, Y. González-Castanedo, I. Garcia-Orellana, S. Nava. Ultrafine particle and fine trace metal (As, Cd, Cu, Pb and Zn) pollution episodes induced by industrial emissions in Huelva, SW Spain. *Atmospheric Environment* 61, 507-517, 2012. DOI: <http://dx.doi.org/10.1016/j.atmosenv.2012.08.003>
- Domínguez-Rodríguez, A., Abreu-Afonso, J., Rodríguez, S., Juárez-Prera, R.A., Arroyo-Ucar, E., Jiménez-Sosa, A., González, Y., Abreu-González, P., Avanzas, P. Comparative Study of Ambient Air Particles in Patients Hospitalized for Heart Failure and Acute Coronary Syndrome. *Revista Española de Cardiología*, 2011;64(8), 661–666, doi:10.1016/j.rec.2010.12.023, 2011.
- Domínguez-Rodríguez, A., Abreu-Afonso, J., Gonzalez, Y., S. Rodríguez, Juarez-Prera, R.A., Arroyo-Ucar, E., Jimenez-Sosa, A., Abreu-Gonzalez, P., Avanzas, P. Relationship between short-term exposure to atmospheric sulfur dioxide and obstructive lesions in acute coronary syndrome. *Medicina Clínica* 140(12), 537-541, 2013. DOI: doi: 10.1016/j.medcli.2012.05.040
- Dominguez-Rodríguez, A., J. Abreu-Afonso, S. Rodríguez, R. A Juarez-Prera, E. Arroyo-Ucara, Y. Gonzalez, P. Abreu-Gonzalez, P. Avanzas. Air pollution and heart failure: Relationship with the ejection fraction. *World Journal of Cardiology* 5(3), 49-53, 2013. DOI: doi:10.4330/wjc.v5.i3.49
- Domínguez-Rodríguez, A., S. Rodríguez, P. Abreu, R. Juárez, P. Avanzas. Impact of AIR pollution on inflammation, oxidative stress and 1-year prognosis in patients hospitalized for Acute COronary Syndrome: design of the AIRACOS study. *Medicina Clínica*, 2013;141(12):529–532
- García, M.I., Rodríguez, S., González, Y., García, R. D. Climatology of new particle formation at Izaña mountain GAW observatory in the subtropical North Atlantic Atmos. Chem. Phys., 14, 3865–3881, 2014 DOI:10.5194/acp-14-3865-2014
- Gómez-Moreno, F.J., Sastre, M. Artíñano, B., Juncal Bello, V., Piñeiro Iglesias, M., López Mahía, P., Pey, J., Ripoll, A., Alastuey, A., Sorribas, M. Fernández, M., de la Morena, B. A., Trujillo de Cabo, J. L., Rodríguez, S. Main activities of the Spanish network on environmental DMAs, European Aerosol Conference, Manchester, 4-9 Sept 2011.
- Gómez-Moreno, F.J., Alonso, E., Artíñano, B., Juncal Bello, V., Piñeiro Iglesias, M., López Mahía, P., Pérez, N., Pey, J., Alastuey, A., de la Morena, B.A., García, M. I., Rodríguez, S., Sorribas, M. Titos, G., Lyamani, H., Alados-Arboledas, L. The Spanish network on environmental DMAs: the 2012 SMPS+UFP intercomparison campaign and study on particle losses in dryers, European Aerosol Conference, Prague, 1-6 Sept 2013.
- Milford, C., Castell, N., Marrero, C., Rodríguez, S., Sánchez de la Campa, A.M., Fernández-Camacho, R., de la Rosa J. and Stein, A.F. Measurements and simulation of speciated PM_{2.5} in south-west Europe, *Atmospheric Environment*, 77, 36-50, 2013.
- Müller, T., B. Henzing, G. de Leeuw, A. Wiedensohler, A. Alastuey, H. Angelov, M. Bizjak, E. Engströmm, C. Gruening, J. Hasselbach, A. Hoffer, K. Imre, P. Ivanow, S. Junying, N. Kalivitis, H. Karlsson, M. Kompula, C. Lunder, A. Marinoni, S. Martins dos Santos, M. Moerman, A. Nowak, J. Ogren, A. Petzold, S. Rodríguez, Shao-Meng, S. Sharma, P. Sheridan, K. Teinilä, T. Tuch, M. Viana, A. Virkkula, E. Weingartner, R. Wilhelm, W. Ya-Qiang. Characterization and Intercomparison of Aerosol Absorption Photometers: results of two intercomparison workshops. *Atmospheric Measurement Techniques*, 4, 245-268, doi:10.5194/amt-4-245-2011, 2011.
- Rodríguez S., A. Alastuey, X. Querol. A review of methods for long term in-situ characterization of aerosol dust. *Aeolian Research*, 6, 55-74, 2012. DOI: <http://dx.doi.org/10.1016/j.aeolia.2012.07.004>
- Rodríguez, S. Updated report of the in-situ aerosol program at Izaña, and feedback to the WCCAP report of the November 2006 audit. March 2014, 2014a. <http://www.wmo-gaw-wcc-aerosol-physics.org/files/station-replay-Izana-2006-Update-Report-by-s.rodriguez-20140325.pdf>
- Rodríguez, S., Cuevas, E., Prospero, J. M., Alastuey, A., Querol, X., López-Solano, J., García, M. I., Alonso-Pérez, S. Modulation of Saharan dust export by the North African dipole. *Atmos. Chem. Phys. Discuss.*, 14, 26689–26719, 2014b.
- Schulz, M., J. M. Prospero, A. R. Baker, F. Dentener, L., Ickes, P.S. Liss, N. M. Mahowald, S. Nickovic, C. Pérez García-Pando, S. Rodríguez, M. Sarin, I. Tegen, R. A. Duce. Atmospheric Transport and Deposition of Mineral Dust to the Ocean: Implications for Research Needs. *Environmental Sciences and Technology*, 46, 10390–10404, 2012. DOI: dx.doi.org/10.1021/es300073u
- Tuch, T.M., Nowak, A. Site audit of IZO, GAW Global station, Izaña, Tenerife. Nov 2006, 2006. http://www.wmo-gaw-wcc-aerosol-physics.org/files/2006_Izana-2014.pdf

8.6 Staff

- Dr Sergio Rodríguez (AEMET; Head of programme)
- Dr Alberto Berjón (AEMET; Research Scientist)
- Dr Javier López Solano (AEMET; Research Scientist)
- Dr Silvia Alonso-Pérez (AEMET; Research Scientist)
- Dr Celia Milford (UHU/AEMET; Research Scientist)
- M. Isabel García (ULL/AEMET; PhD Student)
- Elisa Sosa Trujillo (AEMET; Research Scientist)
- Ramón Ramos (AEMET; Head of Infrastructure)
- Concepción Bayo-Pérez (AEMET; Meteorological Observer-GAW Technician)

9 Column Aerosols

9.1 Main Scientific Goals

The main scientific goals of this programme are:

- Long-term monitoring of atmospheric aerosols in the FT and the MBL.
- Aerosol characterization in the Saharan Air Layer and Marine Boundary Layer.
- Development of new methodologies and instrumentation for column aerosols and water vapour observations, as well as new calibration techniques.
- Mineral dust model validation.
- Satellite borne aerosol data validation.
- Provision of accurate sun and lunar photometer calibrations and intercomparisons.

9.2 Measurement Programme

The measurement programme is very extensive and includes remote sensing sensors at three of the IARC stations, IZO, SCO and TPO (see Tables 3.2, 3.4 and 3.6) and in collaborative stations abroad.

IZO has been a master-sun calibration site for PHOTONS (“PHOtométrie pour le Traitement Opérationnel de Normalisation Satellitaire”) network (CNRS/Lille University, France; PI: Dr Philippe Gouloub) since June 2004. IZO is also the sun-calibration Centre of the Spanish RIMA “Red Ibérica de Medida Fotométrica de Aerosoles” Cimel sunphotometer network (PI: Dr Victoria Cachorro) (Toledano et al., 2011), which is managed by the University of Valladolid Atmospheric Optics Group (GOA-UVA), in collaboration with the IARC. PHOTONS and RIMA are associated networks to AERONET (AERosol RObotic NETwork) (Holben et al., 1998).



Figure 9.1. Cimel masters of the AERONET-Europe Transnational Access (TNA) Calibration Facility.



Figure 9.2. Cimel at Teide Peak Observatory, blocked by ice.

At present the IARC is one of three partners of the AERONET-Europe Calibration Facility Transnational Access (TNA) of the ACTRIS project (Goloub et al., 2012) (see Section 16 for details).

The IARC manages the AERONET sites of IZO, SCO and Tamanrasset (Algeria). Three new AERONET instruments have been deployed by the IARC in Northern Africa (Cairo-Egypt, Tunis-Tunisia and Ouarzazate-Morocco) in the period 2010-2012 thanks to a project funded by the Spanish Agency for International Development Cooperation (AECID) through a Trust Fund of the WMO. This unique network (see Section 20 for details) provides dust information near dust sources over the Sahara and is a key observational facility, within the SDS-WAS Regional Center (see Section 19), for dust modelling and aerosol satellite-based verification and validation activities.

Another important calibration activity is the annual calibration, since 2011, of the Cimel sun photometer Masters of the China Aerosol Remote Sensing NETWORK (CARSNET) managed by the China Meteorological Administration (CMA; Key Laboratory of Atmospheric Chemistry, Centre for Atmosphere Watch and Services, Chinese Academy of Meteorological Sciences). CARSNET has 37 operational sites including the Waliguan global GAW station (Che et al., 2009). CARSNET’s quality control and quality assurance is based on three reference instruments (masters) which must be calibrated with Langley and laboratory radiance calibrations using an integrating sphere.

Langley calibrations of AERONET Cimel sun photometers are complemented with laboratory radiance calibration using the integrating sphere of the Optical calibration facility at IZO (Guirado et al., 2012). IZO, besides being a station of the GAW-PFR network is one of the pristine conditions sites, together with Mauna-Loa, to perform Langley calibrations of the World Radiation Center PFR-Master (Wehrli, 2000). IARC researchers participated in the most recent AERONET Workshop which was held in Valladolid (Spain) on 14-17 October, 2014.

Table 9.1. Technical characteristics of the Micro-Pulse Lidar (MPL) at Santa Cruz de Tenerife Observatory.

Micro-Pulse Lidar version 3 (MPL-3)	
Transmitter	
Laser	Nd:YLF
Wavelength	523 nm
Pulse repetition rate	2500 Hz
Pulse energy	7-10 μ J
Receiver	
Type	Schmidt-Cassegrain
Diameter	20 cm
Focal	2000 mm
Field of view	100 μ rad
Detector	
Type	Avalanche photodiode (APD)
Mode	Photocounting

The IARC and the Spanish Institute for Aerospace Technology (PI: Dr Gil Ojeda) co-manage a Micropulse lidar (MPL) aerosols programme, which started a long-term observation programme in 2005. The instrument is part of the NASA MPLNET worldwide aerosol lidar network. It operates in full-time continuous mode (24 hours a day / 365 days a year) except around noon time periods during the summer solstice. The instrument operated at SCO is the unique aerosol lidar in Northern Africa that provides information about the vertical structure of the Saharan Air Layer over the North Atlantic. The main characteristics of the MPL are detailed in Table 9.1.

IZO was nominated Testbed for Aerosols and Water Vapour Remote Sensing Instruments by the WMO Commission for Instruments and Methods of Observations (WMO-CIMO) in July 2014. During the latter half of 2014 various technical activities related to the CIMO Test-bed facility were carried out at IZO (see Section 23). Some of them linked with absolute sun-calibration of the AERONET-PHOTONS-RIMA network sun photometer masters, tests of the new Precision Solar Spectroradiometer (PSR) from the World Radiation Centre (WRC), absolute irradiance and laboratory radiance calibrations of sun photometers for Tenerife and Northern Africa.

9.3 Summary of remarkable results during the period 2012-2014

In the reporting period we have obtained interesting scientific results concerning processing, reconstruction and assessment of long-term aerosol optical depth (AOD) series at IZO, aerosols characterizations at the GAW Tamanrasset station. The most relevant results are summarized hereinafter.

9.3.1 Intercomparison of AOD and AE (Tenerife)

An intercomparison of AOD and Angstrom exponent (AE) retrievals over Tenerife from multiple ground-based radiometers and space-borne sensors including MODIS (on Terra and Aqua satellites), MISR, OMI, and SeaWiFS was conducted for 2001-2012. A Precision Filter Radiometer from the GAW-PFR Network located at IZO was used as the reference instrument. The intercomparison between PFR and several radiometers including CIMEL sun-photometers which are part of AERONET, a MFRSR and a Physikalisch-Meteorologisches Observatorium Davos (PMOD) sun-photometer collocated at IZO showed that 93.7% of the hourly mean AOD differences at 500 nm between CIMEL and PFR, and 86.3% of the differences between PMOD and PFR ranged between -0.02 and +0.02. The results of AOD and AE intercomparisons between space-borne sensors and ground-based radiometers show that agreement was closer for MISR, MODIS and SeaWiFS instruments, while biases were larger for OMI. These results are being prepared for publication in Atmospheric Measurement Techniques (Romero Campos et al., in preparation).

9.3.2 Column aerosols properties at IZO and SCO

Throughout 2013 a detailed characterization of aerosols in the subtropical free troposphere and Marine Boundary Layer, using data from IZO and SCO AERONET stations and the MPL station, was obtained.

9.3.3 Characterization of aerosols at Tamanrasset: Algeria

Column atmospheric aerosol measurements (2006–2009) at the Tamanrasset site (22.79° N, 5.53° E, 1377 m a.s.l.), in the heart of the Sahara, were analysed (Guirado et al., 2014) using AERONET data from this station (Fig. 9.3). The annual variability of AOD and AE has been found to be strongly linked to the Convective Boundary Layer (CBL) thermodynamic features. The dry-cool season (autumn and winter) is characterized by a shallow CBL and very low mean turbidity (AOD \sim 0.09 at 440 nm, AE \sim 0.62). The wet-hot season (spring and summer) is dominated by high turbidity of coarse dust particles (AE \sim 0.28, AOD \sim 0.39 at 440 nm) and a deep CBL. The aerosol-type characterization

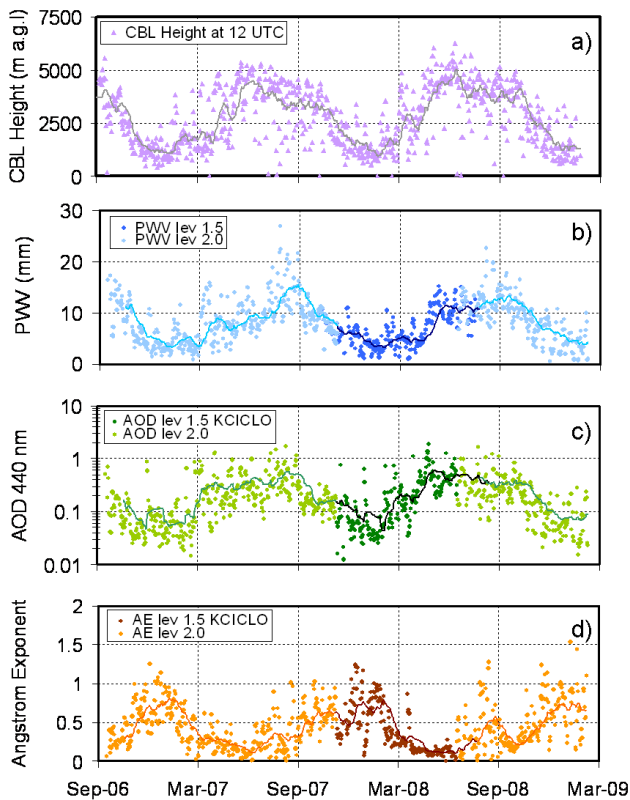

Figure 9.3. Time series of a) CBL height determined from the 12:00 UTC soundings in Tamanrasset, and AERONET daily mean values of b) PWV (mm), c) AOD at 440 nm, and d) AE in the range 440–870 nm. Solid lines correspond to 30-day moving averages. Reprinted from Guirado et al. (2014).

shows desert mineral dust as the prevailing aerosol. Both pure Saharan dust and very clear sky conditions are observed depending on the season. However, several case studies indicate an anthropogenic fine mode contribution from the industrial areas in Libya and Algeria. The concentration weighted trajectory (CWT) source apportionment method was used to identify potential sources of air masses arriving at Tamanrasset at several heights for each season. Microphysical and optical properties and precipitable water vapour were also investigated.

9.3.4 Mark-I astronomical spectrometer: long-term series of column aerosols

Mark-I spectrometer is a reference instrument in helioseismology. It was installed at the nearby (1 km distance from IZO) Instituto de Astrofísica de Canarias (IAC) Teide Observatory in 1976 to study the small velocity fluctuations produced by solar oscillations (“Sun’s eigenmodes”) through high precision measurements of the radial velocity of the Sun viewed as a star (García et al., 2007). This is a potassium-based resonance scattering spectrometer in which a magneto-optic filter allows the study of solar surface and the apparent Doppler velocity in the 769.9 nm resonance line of the neutral potassium atom. This technique presents absolute wavelength reference and better stability than common instruments based on interference filters, such as the sunphotometers. Barreto et al. (2014) used data from this astronomical instrument to recover a long-term series of monochromatic AOD at IZO from these solar irradiance measurements. However, the use of an exposed mirror arrangement to collect the sunlight introduces important inconveniences in instrument calibration through significant drifts in the extraterrestrial voltage (V_0) term. The authors solved this problem using a quasi-continuous Langley calibration technique and a refinement procedure, obtaining the AOD series presented in Fig. 9.4. A subsequent validation analysis between this series and quasi-simultaneously AOD derived from AERONET (Holben et al., 1998) and PFR (Wehrli, 2000) confirmed a good agreement between instruments (see Fig. 9.5), and therefore ensured that Mark-I AOD series can be used together with PFR and AERONET to build a long-term AOD series at IZO that dates back to 1976.

Another important result extracted from this work is that Langley absolute calibration technique can be applied under a priori non-ideal conditions, such as during dust events at IZO, in which relatively high AOD conditions are commonly attained. Those conditions in which the station is within the Saharan Air Layer (SAL) are characterized by high stability in AOD and AE and hence can be considered suitable for Langley calibration. In addition, aerosol stability conditions needed to perform this calibration technique can also be achieved during persistent

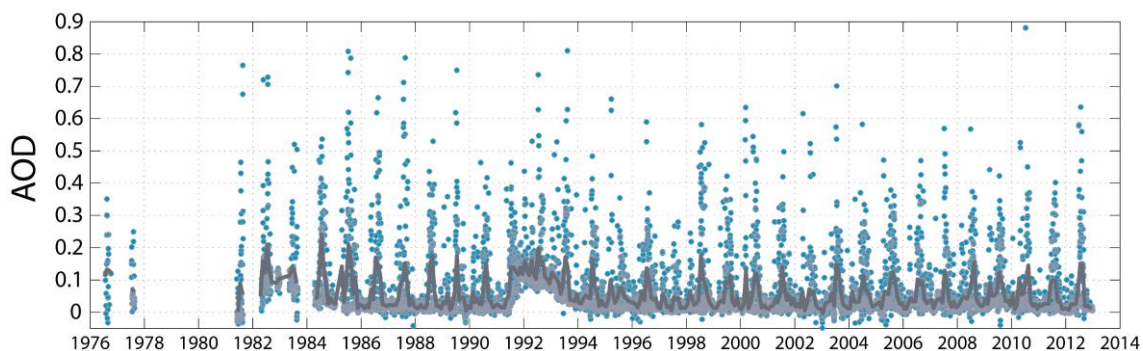

Figure 9.4. Long-term daily AOD at Izaña Atmospheric Observatory extracted from Mark-I at 769.9 nm. Monthly mean homogenized data series is displayed in violet. Figure reprinted from Barreto et al. (2014).

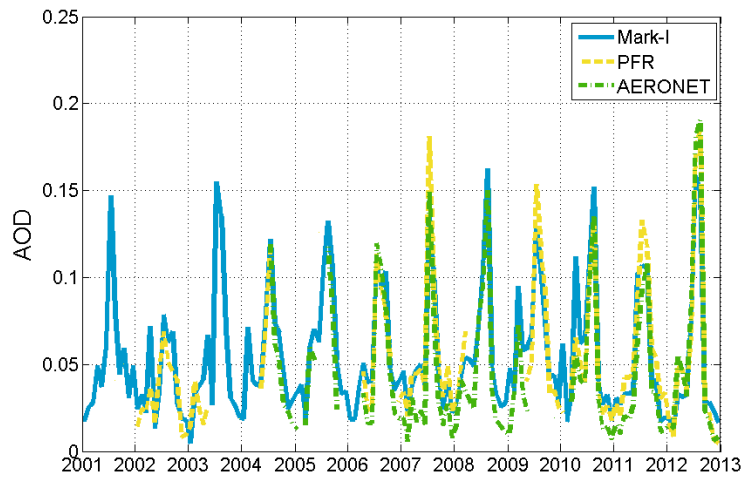

Figure 9.5. Monthly mean homogenized AOD at 769.9 nm extracted from Mark-I from 2001 to 2012 (blue), GAW-PFR 2001-2012 AOD data (yellow) and Cimel-AERONET 2004-2012 level 2.0 AOD data (green). Figure reprinted from Barreto et al. (2014).

stratospheric volcanic aerosols such as those exhibited after Mt. Pinatubo eruption (June 1991). This is an outstanding result because it implies we can perform a reliable calibration in long periods, even in relatively high AOD conditions (AOD up to 0.3), provided AOD and AE remain constant during the Langley calculation.

9.3.5 Reconstruction of a long-term AOD series at IZO

A 73-year time series of the daily aerosol optical depth (AOD) at 500 nm has been reconstructed at IZO. For this purpose, we have combined AOD estimates from neuronal networks (ANNs) from 1941 to 2001 and AOD measurements directly performed with PFR between 2003 and 2013.

The analysis is limited to cloud-free conditions (oktas = 0) and to the summer season (July-August-September), where the largest aerosol load is observed at IZO (Saharan mineral dust particles). The ANNs were trained with PFR data between 2003 and 2009 and take in situ measured meteorological parameters as input variables (visibility, fraction clear sky (FCS) calculated from sunshine duration (SD) measurements and relative humidity). The experimental quality assessment has been performed by comparing the ANNs AOD to coincident AOD data measured with CIMEL Sun Photometers between 2004 and 2009 at 500 nm and with a solar spectrometer Mark-I between 1984 and 2009 at 769 nm.

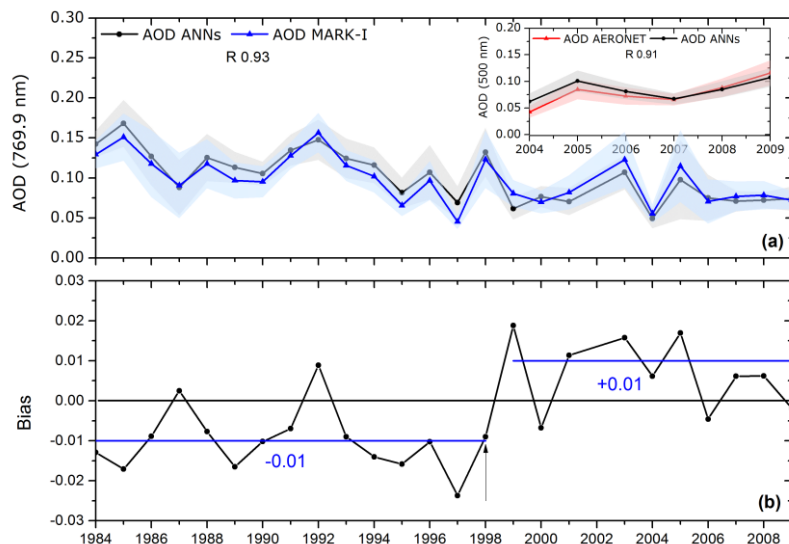

Figure 9.6. (a) Time series of seasonal median (July-August-September) of the AOD Mark-I (blue line) and AOD estimates from ANNs (black line) at 769.9 nm between 1984 and 2009. The insert figure represents time series of seasonal median of AOD AERONET (red line) and AOD ANNs (black line) at 500 nm between 2004 and 2009 at IZO. Shading shows the range of 1 SEM (standard error of the seasonal median). (b) Seasonal median (July-August-September) bias between AOD Mark-I and AOD ANNs at 769.9 nm. The black arrow indicates the change point date and the blue lines represent the median AOD values periods 1984-1998 and 1999-2009.

The observed agreement between ANNs estimates and measurements is rather good, with Pearson correlation coefficients (R) >0.90 (Fig. 9.6). These results have been submitted to publication in Atmospheric Chemistry and Physics (García et al., submitted).

9.3.6 Aerosol vertical profiles

The vertical profiles of extinction obtained with MPL over Tenerife have been used in numerous studies, for example: to obtain preliminary statistics of the vertical structure of aerosols in the subtropical region in summer (Córdoba-Jabonero et al., 2012); to document the vertical distribution of the mineral dust radiative forcing in Tenerife taking advantage of the natural vertical profile formed by the TPO, IZO and SCO AERONET sites (García et al., 2014); to validate the new measurements of nocturnal ODA Lunar-Cimel (Barreto et al., 2013a); and to validate models of mineral dust such as MACC (Cuevas et al., 2014).

9.3.7 Development of new methodologies and techniques to derive AOD, AE and column water vapour

One of the activities that has been a focus over the past three years has been the development of new measurement and calibration methodologies, as well as the development of new instruments in collaboration with national and international research and development and scientific instrumentation companies (see Section 17). This has allowed us to publish technology-oriented R&D results (e.g. Barreto et al., 2013a; 2013b; 2014; Almansa et al., 2014).

9.4 Participation in Campaigns/Experiments

9.4.1 Airborne sun photometer PLASMA absolute calibration field campaigns

The sun tracking photometer PLASMA (Photomètre Léger Aéroporté pour la Surveillance des Masses d'Air) which has been developed by LOA (Laboratoire d'Optique Atmosphérique, CNRS-University of Lille, France) was calibrated at IZO in February 2012 (Karol et al., 2012).

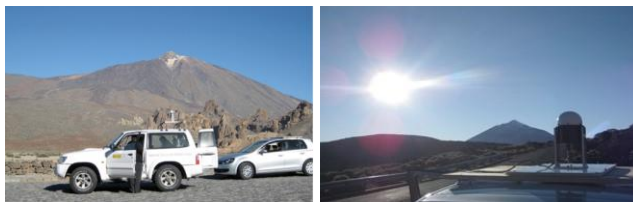

Figure 9.7. PLASMA operating on IARC vehicle (Teide National Park, Tenerife) during the measurement of vertical profiles of AOD, February 2012.

This instrument has been designed to fly onboard an aircraft to provide a vertical profile of the aerosol extinction coefficient as well as information about the aerosol size distribution. The PLASMA photometer has been recalibrated several times at IZO since 2012, particularly in

January 2013, September 2013 and March 2014. In March 2014, vertical profile measurements were also performed with the PLASMA instrument on a plane based at the airport of Los Rodeos (Tenerife Norte). The main goal of the campaigns was to obtain a PLASMA absolute calibration, using the Langley method, with the same accuracy as that for AERONET reference instruments ($0.005 < \Delta AOD < 0.01$). Data obtained with PLASMA were reprocessed with the calibration coefficients derived at IZO. During the experimental campaigns it was also verified that PLASMA system can be operated on a car. PLASMA was installed on the top of an IARC car and two profiles of AOD from sea level to 2400 m a.s.l. were obtained (Fig. 9.7).

9.4.2 Sunphotometer Airborne Validation Experiment 2012

The main objective of the Sunphotometer Airborne Validation Experiment 2012 was to validate columnar integrated aerosol properties retrieved by AERONET and SKYNET from ground sunphotometric measurements, with the integrated vertical profiles of airborne in situ aerosol measurements (Estellés et al., 2013). This campaign was held in Tenerife and Western Sahara areas, during June 2012. During this campaign, a Prede POM01L sun-sky radiometer from Burjassot (University of Valencia) was collocated with the Cimel sun photometer in SCO to validate the Prede retrievals and to study the Saharan dust properties.

9.4.3 Ceilometer-MPL intercomparison in 2012

A comparison of the Planetary Boundary Layer and Saharan Air Layer top height retrievals was conducted using a Vaisala CL-51 Ceilometer and the SCO Micro Pulse Lidar (Hernández et al., 2012).

9.4.4 AMISOC intensive campaign in summer 2013

Vertical aerosols profiles from the MPL play a key role in the Atmospheric Minor Species relevant to the Ozone Chemistry at both sides of the Subtropical jet (AMISOC) campaign performed in summer 2013 (Córdoba-Jabonero et al., 2014).

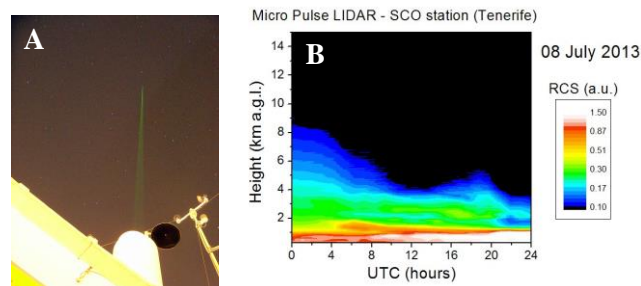

Figure 9.8. A) Micropulse lidar ray-tracing during the night B) Aerosols and clouds back-scatter signal vertical cross-section over Santa Cruz de Tenerife on July 8th, 2013.

The main aim of this campaign was to improve the knowledge of the role that minor constituents in the atmosphere play in ozone chemistry. In this campaign a great variety of instruments participated namely “in situ” and remote sensing ground-based and aircraft sensors. Details of the campaign can be found on the [AMISOC web page](#).

9.5 References

- Almansa, F., E. Cuevas, C. López, A. Barreto, A. De Frutos, Aerosol optical depth inferred from zenith sky measurements using a new multifilter radiometer, Book of Abstracts, p 17, International Conference on ATMOSPHERIC DUST, Castellana Marina, Italy, June 1-6, 2014
- Barreto, A., Cuevas, E., Damiri, B., Guirado, C., Berkoff, T., Berjón, A. J., Hernández, Y., Almansa, F., and Gil, M.: A new method for nocturnal aerosol measurements with a lunar photometer prototype, *Atmos. Meas. Tech.*, 6, 585-598, doi:10.5194/amt-6-585-2013, 2013a.
- Barreto, A., Cuevas, E., Damiri, B., Romero, P. M., and Almansa, F.: Column water vapor determination in night period with a lunar photometer prototype, *Atmos. Meas. Tech.*, 6, 2159-2167, doi:10.5194/amt-6-2159-2013, 2013b.
- Barreto, A., E. Cuevas, P. Pallé, P. M. Romero, C. Guirado, C. J. Wehrli and F. Almansa: Recovering long-term aerosol optical depth series (1976-2012) from an astronomical potassium-based resonance scattering spectrometer, *Atmospheric Measurement Techniques*, 7, 1-14, doi: 10.5194/amt-7-1-2014, 2014.
- Che, H., Zhang, X. Y., Chen, H. B., Damiri, B., Goloub, P., Li, Z. Q., Zhang, X. C., Wei, Y., Zhou, H. G., Dong, F., Li, D. P., and Zhou, T. M.: Instrument calibration and aerosol optical depth validation of the China Aerosol Remote Sensing Network, *J. Geophys. Res.*, 114, D03206, doi:10.1029/2008JD011030, 2009.
- Córdoba-Jabonero, C., D. Toledo, J.A. Adame, Y. Hernández, E. Cuevas, M. Gil, Saharan Air Layer (SAL) over Tenerife: Summertime statistic analysis from lidar measurements, 2012 European Aerosol Conference (EAC-2012), B-WG01S2P13, Granada-Spain, 2- 7 September, 2012.
- Córdoba-Jabonero, C., J. Andrey, L. Gómez, M.C. Parrondo, J. A. Adame, O. Puente, E. Cuevas, M. Gil-Ojeda, Multiplatform in-situ and remote sensing techniques to derive Saharan dust properties during AMISOC-TNF 2013, *Proc. SPIE* 9242, Amsterdam, 24-25 September, 2014, Remote Sensing of Clouds and the Atmosphere XIX; and Optics in Atmospheric Propagation and Adaptive Systems XVII, 924209 doi: 10.1117/12.2067173, 17 October 2014.
- Cuevas, E., Camino, C., Benedetti, A., Basart, S., Terradellas, E., Baldasano, J. M., Morcrette, J.-J., Marticorena, B., Goloub, P., Mortier, A., Berjón, A., Hernández, Y., Gil-Ojeda, M., and Schulz, M.: The MACC-II 2007–2008 reanalysis: atmospheric dust evaluation and characterization over Northern Africa and Middle East, *Atmos. Chem. Phys. Discuss.*, 14, 27797-27879, doi:10.5194/acpd-14-27797-2014, 2014.
- Estellés, V., Marengo, F., Ryder, C. L., Campanelli, M., Expósito, F., Solá, Y., Segura, S., Marcos, C., Toledano, C., Berjón, A., Guirado, C., Claxton, B., Todd, M.: The Sunphotometer Airborne Validation Experiment 2012: Preliminary Results, *Geophysical Research Abstracts*, 15, EGU2013-5580, 2013.
- García, R.A., Turck-Chieze, S., Jiménez-Reyes, S.J., Ballot, J., Pallé, P. L., Eff-Darwich, A., Mathur, S., and Provost, J.: Tracking Solar Gravity Modes: The Dynamics of the Solar Core, *Science*, 316, 5831, 1591--1593, doi: 10.1126/science.1140598, 2007.
- García, R.D., García O.E, Cachorro, V.E., Cuevas, E., Guirado, C., Hernández, Y., Berjón, A., and de Frutos, A.M. Vertical distribution of the mineral dust radiative forcing in Tenerife. 2nd Iberian Meeting on Aerosol Science and Technology, 7-9 July, Tarragona (Spain), 2014.
- García, R.D, O.E. García, E. Cuevas, V.E. Cachorro, A. Barreto, C. Guirado, N. Kouremeti, J.J. Bustos, S. Rodríguez and A.M. de Frutos, AOD reconstruction using neural networks: Long-term Saharan dust outbreaks records over the Subtropical North Atlantic, Submitted to *Atmos. Chem. Phys.*
- Goloub, P., V. E. Cachorro, E. Cuevas, L. Blarel, A. Berjón, C. Toledano, A. Lapionak, C. Guirado, R. Ramos, R. González, D. Fuertes, The AERONET-Europe calibration facility: access within the ACTRIS Project, 2012 European Aerosol Conference (EAC-2012), B-SS01S1P12, Granada-Spain, 2- 7 September, 2012.
- Guirado, C., R. Ramos, A. M. de Frutos, A. Berjón, A. Redondas, C. López, V. E. Cachorro, E. Cuevas, R. González, S. González, M. Hernández, Optical calibration facility at the Izaña Atmospheric Research Center, *Opt. Pura Apl.*, 45 (1) 57-62, Special Section: 37th AMASOM Instrumentation and Techniques, 2012.
- Guirado, C., Cuevas, E., Cachorro, V. E., Toledano, C., Alonso-Pérez, S., Bustos, J. J., Basart, S., Romero, P. M., Camino, C., Mimouni, M., Zeudmi, L., Goloub, P., Baldasano, J. M., and de Frutos, A. M.: Aerosol characterization at the Saharan AERONET site Tamanrasset, *Atmos. Chem. Phys.*, 14, 11753-11773, doi:10.5194/acp-14-11753-2014, 2014.
- Hernández, Y., S. Alonso-Pérez, E. Cuevas, J. de Bustos, A. Gomez-Pelaez, R. Ramos, C. Córdoba-Jabonero. and M. Gil, Planetary Boundary Layer and Saharan Air Layer top height determination using Ceilometer and Micro Pulse Lidar. Intercomparison for two case studies, 2012 European Aerosol Conference (EAC-2012), A-WG02S1P51, Granada-Spain, 2- 7 September, 2012.
- Holben, B. N., Eck, T. F., Slutsker, I., Tanré, D., Buis, J. P., Setzer, A., Vermote, E., Reagan, J. A., Kaufman, Y. J., Nakajima, T., Lavenu, F., Jankowiak, I. And Smirnov A.: AERONET- A federated instrument network and data archive for aerosol characterization, *Rem. Sens. Environ.*, 66, 1-16, 1998.
- Karol, Y., Tanré, D., Goloub, P., Vervaerde, C., Balois, J. Y., Blarel, L., Podvin, T., Mortier, A., and Chaikovskiy, A.: Airborne sunphotometer PLASMA: concept, measurements, comparison of aerosol extinction vertical profile with lidar, *Atmos. Meas. Tech. Discuss.*, 5, 6813-6834, doi: 10.5194/amtd-5-6813-2012, 2012.
- Romero-Campos, P.M., E. Cuevas, C. Guirado, R.D. García, C. Wehrli, S. Nyeki, and N. Kouremeti, An Intercomparison of Aerosol Optical Properties obtained from Ground-based and satellite Radiometers on Tenerife Island between 2001 and 2012, in preparation, to be submitted to *Atmospheric Measurement Techniques*.
- Toledano, C., V. E. Cachorro, A. Berjón, A. M. de Frutos, D. Fuertes, R. Gonzalez, B. Torres, R. Rodrigo, Y. Bennouna, L. Martín, C. Guirado, RIMA-AERONET network: long-term monitoring of aerosol properties. *Opt. Pura Apl.*, 44 (4) 635-639, Special Section: 37th AMASOM Instrumentation and Techniques, 2011.

Wehrli, C.J., Calibrations of filter radiometers for determination of atmospheric optical depth, *Metrologia*, 37, 419-422, doi: 10.1088/0026-1394/37/5/16, 2000.

9.6 Staff

Dr Emilio Cuevas (AEMET; Head of programme)

Carmen Guirado Fuentes (UVA/AEMET; Research Scientist)

Yballa Hernández-Pérez (AEMET; Research Scientist)

Dr Alberto Berjón (AEMET; Research Scientist)

Ramón Ramos (AEMET; Head of Infrastructure)

Pedro Miguel Romero (AEMET; Research Scientist)

Dr África Barreto (AEMET/CIMEL; Research Scientist)

Dr Rosa García (UVA/ AEMET; Research Scientist)

Dr Omaira García (AEMET; Research Scientist)

Fernando Almansa (AEMET/CIMEL; Research Scientist)

Dr Victoria Cachorro (University of Valladolid; Head of Atmospheric Optics Group)

Dr Ángel de Frutos (University of Valladolid Atmospheric Optics Group; Research Scientist)

Dr Manuel Gil Ojeda (INTA; Co-PI in MPL sub-programme)

10 Radiation

The radiation programme, and specifically the implementation of its core component, the Baseline Surface Radiation Network (BSRN) programme, has been performed in close collaboration with the [University of Valladolid Atmospheric Optics Group](#).

10.1 Main Scientific Goals

The main scientific goals of this programme are:

- The long-term maintenance of the Baseline Surface Radiation Network (BSRN) programme, and the corresponding quality control system.
- To investigate the variations of the solar radiation balance and other solar energy parameters in the three radiation stations managed by the IARC.
- To investigate aerosols radiative forcing with a particular focus on the role played by dust taking advantage of the privileged situation of the Canary Islands to analyse dust outbreaks over the North Atlantic and the unique local radiation network with stations at different altitudes (from sea level to 3555 m a.s.l.).
- To recover, digitize and analyse historical radiation data in order to reconstruct long radiation series that allow us to make precise studies concerning sky darkening and brightening, and relate radiation to cloud cover and solar flux.

10.2 Measurement Programme

Direct radiation records from an Abbot silver-disk pyrheliometer are available since 1916, although this information has not yet been analysed. Global solar radiation records from a bimetallic pyranograph are available both in bands and as daily integrated values in printed lists, since 1976. This information is now being digitized, recalibrated and processed. Preliminary results show a surprising excellent agreement between the bimetallic pyranograph and the BSRN CM21 pyranometer, which suggests we will recover the global radiation data series since 1977 successfully, after a careful analysis of historical data.

Global and direct radiation measurements started in 1992 as part of a solar radiation project of the Canary Islands Government. In 2005, IZO joined the Spanish radiation network managed by the AEMET National Radiation Center (CNR). Since 2009, IZO has been a BSRN station providing the basic set of parameters. In addition, other parameters, including shortwave and long wave upward radiation, UV-A and UV-B radiation are also measured within the BSRN Programme. Later, some basic radiation

measurements were implemented at IARC's satellite-stations of SCO, TPO and BTO. A description of the radiation measurement programme managed by the IARC is shown in Table 10.1.

Radiation measurements are tested against physically possible and globally extremely rare limits, as defined and used in the BSRN recommended data quality control. Shortwave downward radiation (SDR) measurements are compared daily with SDR simulations, which are modelled with the LibRadtran model. This information has been implemented in the web page <http://bsrn.aemet.es/>, where real time measurements of global, direct, diffuse and UV-B radiation are shown. Complementary radiation observations from the CNR at SCO are also available (see Table 10.1).

The atmospheric transmission is a new product implemented in 2014 and processed retrospectively up until 2009 (Fig. 10.1), which is available at the IZO's BSRN web page. The atmospheric transmission is derived from broadband (0.2 to 4.0 μm) direct solar irradiance BSRN observations. Data are for clear-sky mornings between solar elevations of 11.3° and 30°.

Sky images from SONA total-sky cameras at IZO and SCO, meteorological vertical profiles from radiosondes, AOD and AE from Cimel and PFR sunphotometers, column water vapour from Cimel and GPS/GLONASS, column NO₂ from DOAS, and total O₃ from Brewer spectrophotometer are used as ancillary data and/or as input data in LibRadtran simulations.

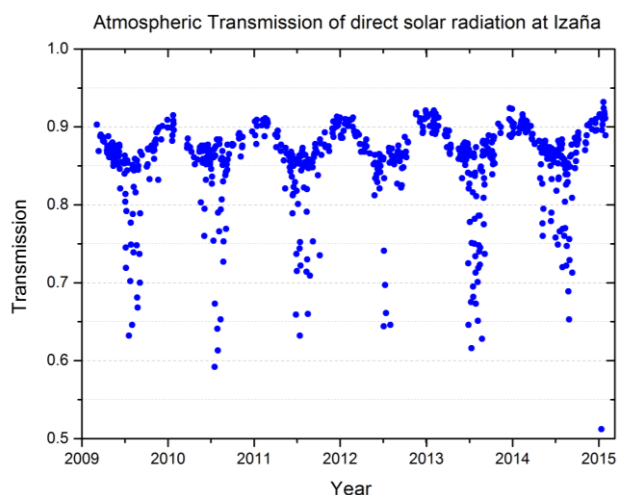

Figure 10.1. Daily atmospheric transmission data at IZO computed in clear-sky mornings between solar elevations of 11.3° and 30°.

Table 10.1. Details of IARC radiation measurement programme.

Instrument	Measurements	Spectral Range
Izaña historical records (2373 m a.s.l.) Start Date: Different dates		
Abbot silver-disk pyrheliometer	Direct Radiation (1916)	~0.3 to ~3.0 μm
Bimetallic pyranograph (analog.)	Global Radiation (Jan 1977)	~0.3 to ~3.0 μm
YES Multi Filter Rotating Shadow-band Radiometer	Global, diffuse and estimated direct radiation (Feb 1996)	300-1200 nm
K&Z CM5 pyranometer	Global radiation (Jan 1992)	310-2800 nm
Izaña BSRN Station (2373 m a.s.l.) Start Date: March 2009		
Pyranometer K&Z CM-21	Global and Diffuse Radiation	285-2600 nm
Pyrheliometer K&Z CH-1	Direct Radiation	200-4000 nm
Pyrgeometer K&Z CG-4	Longwave Downward Radiation	4500-42000 nm
Pyranometer K&Z UV-A-S-T	UV-A Radiation	315-400 nm
Pyranometer Yankee YES UVB-1	UV-B Radiation	280-400 nm
Absolute Cavity Pyrheliometer PMO6	Direct Radiation	-
Izaña National Radiation Center (CNR) Station (2373 m a.s.l.) Start Date: August 2005		
Pyranometer K&Z CM-21	Global and Diffuse Radiation	285-2600 nm
Pyrheliometer K&Z CH-1	Direct Radiation	200-4000 nm
Pyrgeometer K&Z CG-4	Longwave Downward Radiation	4500-42000 nm
Pyranometer Yankee YES UVB-1	UV-B Radiation	280-400 nm
Pyranometer K&Z PQS1	Photosynthetically Active Radiation (PAR)	400-700 nm
SCO (52 m a.s.l.) Start Date: February 2006		
Pyranometer K&Z CM-11	Global and Diffuse Radiation	310-2800 nm
Pyrheliometer EPPLY	Direct Radiation	200-4000 nm
BTO (114 m a.s.l.) Start Date: 2009		
Pyranometer K&Z CM-11	Global and Diffuse Radiation	310-2800 nm
TPO (3555 m a.s.l.) Start Date: July 2012		
Pyranometer K&Z CM-11	Global and Diffuse Radiation	310-2800 nm
Pyranometer Yankee YES UVB-1	UV-B Radiation	280-400 nm

10.3 Summary of remarkable results during the period 2012-2014

10.3.1 Mineral dust radiative forcing

A comparative study of shortwave downward radiation (SDR) measurements and simulations with the LibRadtran radiative transfer model (RTM) has been performed on cloud-free days between March 2009 and August 2012 (386 days), including aerosol-free and Saharan mostly pure mineral dust conditions (García et al., 2013; 2014a). The observed agreement between simulations and measurements is excellent; the variance of daily measurements overall agrees within 99% with the variance of daily simulations, and the mean bias (simulations minus measurements) is $-0.30 \pm 0.24 \text{ MJm}^{-2}$, $-0.16 \pm 0.34 \text{ MJm}^{-2}$, and $+0.02 \pm 0.25 \text{ MJm}^{-2}$ for global, direct, and diffuse radiation, respectively. This work has permitted us to obtain diurnally averaged Saharan mineral dust aerosol radiative forcing (ΔDF) and radiative forcing efficiency ($\Delta\text{DF}^{\text{eff}}$). The mean ΔDF values are -7 ± 1 , -96 ± 5 and $44 \pm 2 \text{ Wm}^{-2}$ for global, direct and diffuse BSRN SDR, respectively, while the mean $\Delta\text{DF}^{\text{eff}}$ values are -59 ± 6 , -495 ± 11 and $230 \pm 8 \text{ Wm}^{-2}$ per unit of AOD at 500 nm for global, direct and diffuse BSRN SDR, respectively (Fig. 10.2). These results show the significant potential of mineral dust particles to cool the Earth-atmosphere system at ground level.

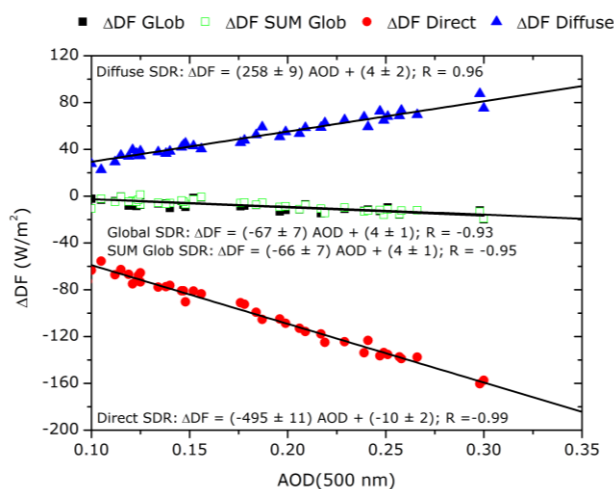

Figure 10.2. Diurnally averaged aerosol radiative forcing (ΔDF) versus the daily averaged AOD at 500 nm for global (black squares), SUM Glob (green squares), direct (red dots) and diffuse SDR (blue triangles) for all cloud-free days with daily averaged AOD > 0.10 and $\alpha < 0.75$ from March 2009 to August 2012 at BSRN IZA (N=39 days). The black solid lines are the least square fits, where the slopes represent the diurnally averaged aerosol radiative forcing efficiency ($\Delta\text{DF}^{\text{eff}}$ -slope).

In collaboration with the In situ Aerosols group, we are conducting research on radiative forcing and efficiency of desert dust coated with anthropogenic and natural pollutants

(SO_4^{2-} , NO_3^- , NH_4^+). Preliminary results are shown in Rodríguez et al. (2014).

10.3.2 The vertical distribution of the Saharan mineral dust radiative forcing and radiative forcing efficiency

The vertical distribution of the Saharan mineral dust radiative forcing (ΔF) and radiative forcing efficiency ($\Delta\text{F}^{\text{eff}}$) has been studied from sea level to about 3.5 km altitude in Tenerife. We combine global solar radiation (GSR) and aerosol optical properties measured at three of the IARC observatories: SCO (52 m a.s.l.), IZO (2373 m a.s.l.) and TPO (3555 m a.s.l.).

The mean ΔF values are -27 ± 6 , -11 ± 5 and $-10 \pm 3 \text{ Wm}^{-2}$ for SCO, IZO and TPO, respectively (mean AOD at 500 nm of 0.28 ± 0.05 , 0.16 ± 0.04 and 0.10 ± 0.02), while the mean $\Delta\text{F}^{\text{eff}}$ values are -123 ± 4 , -126 ± 3 and $-103 \pm 7 \text{ Wm}^{-2}$ per unit of AOD at 500 nm for SCO, IZO and TPO, respectively (Fig. 10.3). The $\Delta\text{F}^{\text{eff}}$ values are rather consistent in the vertical and, then, well representative of Saharan mineral dust. These results (García et al., 2014b) confirm the significant potential of mineral dust particles to cool the Earth-atmosphere system at different altitudes.

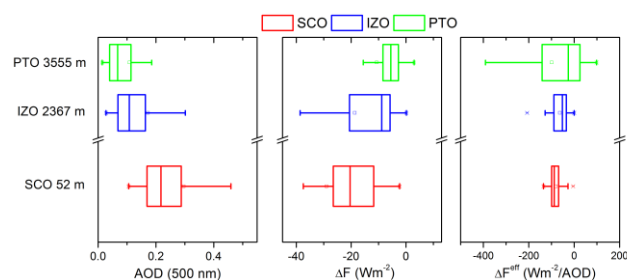

Figure 10.3. Vertical distribution of the AOD, ΔF and $\Delta\text{F}^{\text{eff}}$ values in July-August 2013 at three stations. Lower and upper boundaries for each box are the 25th and 75th percentiles, the solid line is the median value, the crosses indicate values out of the 1.5 fold box area.

10.3.3 Long-term global radiation series reconstruction

We have performed the reconstruction of the global solar radiation time series between 1933 and 2013 at IZO by using the Ångström-Prešcott method based on sunshine duration measurements (1933-1991) and the GSR observations directly performed by pyranometers (1992-2013) (García et al., 2014c; 2014d). By comparing with high quality GSR measurements, the precision and consistency over time of GSR estimations from SD data have successfully been documented. We obtain an overall root mean square error (RMSE) of 9.2 % and an agreement between the variances of GSR estimations and GSR measurements within 92% (correlation coefficient of 0.96).

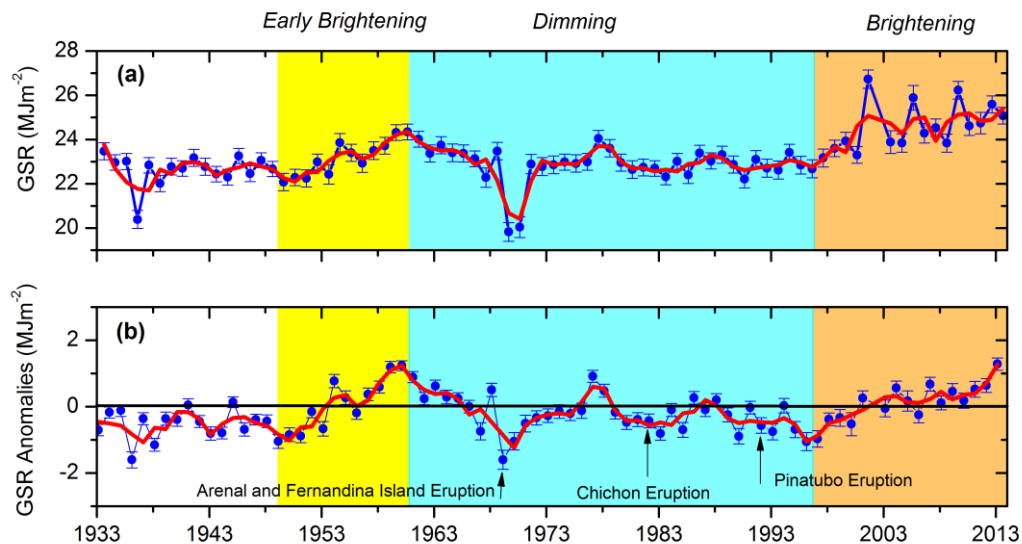

Figure 10.4. Time series of annual means of (a) Global Solar Radiation (GSR) and (b) GSR anomalies from 1933 to 2013 at IZO. The error bars indicate ± 1 SEM (standard error of the mean). The arrows indicate the eruptions of Arenal and Fernandina (1968), Chichón (1982) and Pinatubo (1991) volcanoes. The five-yr moving average is shown in red. The time series has been deseasonalized by subtracting the averaged GSR annual cycle, and obtaining the annual mean anomalies time series.

The reconstructed GSR time series between 1933 and 2013 at IZO confirms discontinuities and periods of increases/decreases of solar radiation at Earth's surface observed at a global scale, such as the early brightening, dimming and brightening (Fig. 10.4). This fact supports the consistency of the IZO GSR time series obtained, which may be considered as a reference for long-term solar radiation studies in the subtropical North Atlantic region.

10.4 Participation in Scientific Projects and Campaigns/Experiments

10.4.1 Calibration campaign of BSRN instruments with a PMO6 Absolute Cavity Pyrheliometer

As part of the radiation quality assurance system a calibration campaign of BSRN pyranometers and pyrliometer was performed during summer 2014 using an Absolute Cavity Pyrheliometer PMO6 as reference (Fig. 10.5). The PMO6 was calibrated in the World Radiation Center (WRC) Davos. The BSRN instruments were calibrated following the ISO 9059:1990 (E) and ISO 9846:1993(E), delivering the corresponding official calibration certificates. Preliminary results of this calibration traceable to WRC were presented to the 13th BSRN Scientific Review and Workshop (Cuevas et al., 2014).



Figure 10.5. Absolute cavity radiometer (PMO6) installed at IZO during summer 2014 in the sun-tracker of the BSRN.

10.4.2 Intercomparison of traditional and modern radiation instruments

A one-year intercomparison of traditional and modern radiation and sunshine duration instruments started in July 2014 (Fig. 10.6). The radiation instruments include a bimetallic pyranometer, CM-5, CM-11, CM-21, and Multi Filter Rotating Shadow-band Radiometer (MFRSR) (Table 10.1) while the sunshine duration measurements include a Campbell-Stokes sunshine recorder, sunshine duration sensor, and those derived from direct radiation. The main aim of this intercomparison is to examine any systematic and seasonal variations that may exist between traditional and modern measurement systems that have been installed in IZO. This enables us to quantify the various measurement uncertainties, when we study the long-term data series obtained from these instruments.



Figure 10.6. Campbell-Stokes sunshine recorder, bimetallic pyranometer, and Kipp & Zonen CM-21 pyranometer installed currently at IZO during the one-year intercomparison.

10.5 Future activities

The main on-going and future activities are focused on:

- Recovery of GSR data from the bimetallic pyranometer (now printed on paper) from 1977-1991, making the appropriate data recalibration and reprocessing using simulations with LibRadtran, and considering the results from the one-year intercomparison campaign.
- Reconstruction and accurate analysis of a new long GSR data series (since 1916) in which newly recovered observation data are being incorporated. Long-term records of aerosols (AOD), cloudiness, and solar flux will be compared with GSR data.
- Apparent transmission data recovery from direct radiation measured with ancient Abbot silver-plate pyrheliometers (since 1916) and comparison with present results.
- Accurate determination of cloud attenuation on global radiation using GSR from SCO and BTO.
- Accurate analysis of UV-B broadband data from the vertical transect formed by SCO (52 m a.s.l.), IZO (2373 m a.s.l) and TPO (3555 m a.s.l.) observatories, with complementary information on cloudiness, AOD and O₃ vertical profiles (ECC O₃ sondes).

10.6 References

- Cuevas, E., García, R.D., Ramos, R., Cachorro, V.E., and de Frutos, A.M. Status of the Izaña BSRN station and future activities. 13th BSRN Scientific Review and Workshop Bologna (Italy) September 9-12, 2014.
- García, R.D., O.E. García, E. Cuevas, V.E. Cachorro, P.M. Romero-Campos, R. Ramos and A.M de Frutos, Mineral dust radiative forcing and efficiency at the BSRN Izaña station, The 1st Iberian Meeting on Aerosol Science and Technology – RICTA 2013, Evora, Portugal, 1-3 July 2013.
- García, R. D., O. E. García, E. Cuevas, V. E. Cachorro, P. M. Romero-Campos, R. Ramos, and A. M. de Frutos, Solar radiation measurements compared to simulations at the BSRN Izaña station: Mineral dust radiative forcing and efficiency study, *J. Geophys. Res. Atmos.*, 119, 179–194, doi:10.1002/2013JD020301, 2014a.
- García, R.D., García O.E, Cachorro, V.E., Cuevas, E., Guirado, C., Hernández, Y., Berjón, A., and de Frutos, A.M. Vertical distribution of the mineral dust radiative forcing in Tenerife. 2nd Iberian Meeting on Aerosol Science and Technology, 7-9 July, Tarragona (Spain), 2014b.

García, R.D., García, O.E., Cuevas, E., Cachorro, V.E., and de Frutos, A.M. Long-Term in global solar radiation at the Izaña Atmospheric Observatory from 1933-2013. 13th BSRN Scientific Review and Workshop Bologna (Italy) September 9-12, 2014c.

García, R. D., Cuevas, E., García, O. E., Cachorro, V. E., Pallé, P., Bustos, J. J., and de Frutos, A. M., Reconstruction of global solar radiation time series from 1933 to 2013 at the Izaña Atmospheric Observatory. *Atmospheric Measurement Techniques*, 7(9), 3139-3150, doi:10.5194/amt-7-3139-2014, 2014d.

Rodríguez, S., J.M. Prospero, M.I. García, A. Alastuey, R.D. García, J. López-Solano, E. Cuevas, X. Querol, Long term 1987 - 2012 trends of sulfate, nitrate and dust mixing in the Saharan Air Layer. Symposium on Atmospheric Chemistry and Physics at Mountain Sites, Steamboat Springs, CO, USA., August 11-15, 2014.

10.7 Staff

Dr Emilio Cuevas (AEMET; Head of programme)

Dr Rosa García (UVA/AEMET; Co-PI)

Ramón Ramos (AEMET; Head of Infrastructure)

Dr Omaira García (AEMET; Research Scientist)

Pedro Miguel Romero (AEMET; Research Scientist)

Dr Fernando de Ory (AEMET; Meteorological Observer-GAW Technician)

Dr Victoria Cachorro (University of Valladolid; Head of Atmospheric Optics Group)

Dr Ángel de Frutos (University of Valladolid Atmospheric Optics Group; Research Scientist)

11 Differential Optical Absorption Spectroscopy (DOAS)

11.1 Main Scientific Goals

Differential Optical Absorption Spectroscopy (DOAS) and Multi Axis Differential Optical Absorption Spectroscopy (MAXDOAS) techniques allow the determination of atmospheric trace gases present in very low concentrations. The long term monitoring of atmospheric trace gases is of a great interest for trend studies and satellite validation. The simultaneous detection of gases using DOAS or MAXDOAS technique allows the study of mutual interaction between gases even when detection limits of the gases are low.

The main scientific goals of the DOAS and MAXDOAS programme are:

- To improve the knowledge of the distribution, seasonal behaviour and long term trends of minor constituents related to ozone equilibrium such as NO₂, BrO and IO and their distribution in the subtropical atmosphere.
- To obtain a climatology of stratospheric NO₂ and BrO in subtropical regions and its dependence on environmental and climatic variables.
- To study the seasonal variation of NO₂, O₃, HCHO and IO in the free troposphere and its interaction with environmental factors such as Saharan dust amongst others.
- To participate in the validation of NO₂ and Ozone satellite products (GOME, GOME2, SCIAMACHY, OMI, TROPOMI) and in the improvement of the methodology to perform such intercomparisons.

11.2 Measurement Programme

The DOAS technique (Platt and Stutz, 2008) is a method to determine the atmospheric trace gases column density by measuring their absorption structures in the near ultraviolet and visible spectral region.



Figure 11.1. RASAS II and ARTIST II MAXDOAS (UV-VIS) spectroradiometers at IZO.



Figure 11.2. DOAS instruments outdoor optics with sky trackers.

The technique is based on measurement of atmospheric absorption of solar radiation at selected wavelength bands where the gas under consideration shows a structured and known absorption cross-section. For stratospheric observations the instrument is pointed at zenith during the twilights.

Although the DOAS technique was developed for stratospheric research, during the last few years it has been largely employed in tropospheric background and pollution episodes studies. In particular, the so called Multi Axis Differential Optical Absorption Spectroscopy approach allows to infer vertical distribution of minor species from spectrometric measurements of solar scattered light at given angles of elevation (off-axis measurements). The analysis technique makes use of the Optical Estimation Method (Rodgers, 2000) by putting together the off-axis measurements and a radiative transfer algorithm to get the best solution for all used elevation angles.

The instruments automatically take spectra from an AM SZA = 96° to PM SZA = 96°, every day. As the instrument must work with a stabilized room temperature and also with a stabilized internal temperature and humidity, those parameters are monitored and recorded in data files. Calibration of the instrument grating is performed approximately every year. Calibration of the elevation angle is performed once a month. After the spectral inversion, a quality control of data is carried out. The acquired data are filtered on the basis of the analysis and instrumental error, aerosol optical thickness and the solar zenith angles, to ensure quality.

INTA has performed measurements of stratospheric O₃ and NO₂ at IZO since 1993. Data have been used for the study of stratospheric O₃ and NO₂ distribution in the subtropical region (Gil et al. 2004, Gil et al., 2008) and for validation of satellite products (Meijer et al., 2004, Lambert et al., 2007, Hendrick et al. 2011). In 2003, the installation of an ultraviolet DOAS spectrometer expanded the measurements of stratospheric gases to the near ultraviolet region, allowing the monitoring of stratospheric BrO and to estimate the

concentration of free tropospheric BrO (Puentedura, 2004). More recently, in 2010, the instruments were adapted to MAXDOAS measurements, allowing the detection of free tropospheric trace gases, such as IO and NO₂ (Puentedura et al, 2012, Gomez et al., 2014). In the case of BrO, its tropospheric concentration was confirmed to a lower limit of 1 pptv. Prior to the installation at IZO in 2009, the VIS-MAXDOAS instrument participated in the international blind NO₂ MAXDOAS intercomparison campaign CINDI (Cabauw Intercomparison campaign Nitrogen Dioxide measuring Instrument) (Roscoe et al., 2010, PETERS et al., 2012, Pinardi et al., 2013). During the AMISOC campaign in 2013, extensive measurements of IO were performed at three different altitude levels on Tenerife. Data are currently under revision

11.3 Summary of remarkable results during the period 2012-2014

11.3.1 Measurements of Free Tropospheric IO

The installation of Vis-MAXDOAS in 2009 allowed the detection of IO in the free troposphere. This was the first time that this specie was detected and measured in this layer, yielding slant column densities consistent with a background concentration of 0.2-0.4 pptv in the free troposphere of marine regions and opening the question about the origin of IO in this layer (Puentedura et al., 2012).

11.3.2 Reanalysis of stratospheric NO₂ and O₃ data series

In the frame of the European NORS project, the long term data series of NO₂ and O₃ have been reanalysed adapting the analysis setting to NDACC recommendations. Results for the NO₂ data series are shown in Fig. 11.3, and results for O₃ (Gil et al., 2012) are shown in Fig. 11.4.

11.3.3 Seasonal evolution of background NO₂ in the free troposphere

Gomez et al (2104) have presented a simple method based on a Modified Geometrical Approximation to estimate the tracers concentration at the level of IZO from MAXDOAS measurements. Gil-Ojeda et al. (2015) used 3 years (2011-2013) spectra to analyse the seasonal evolution of the NO₂ volume mixing ratio. MAXDOAS presents two main advantages with respect to the in situ instrument at this location, both related to the very long optical path of the measurements over 60 km. Firstly, it minimizes the potential NO₂ which may be upwelled from the marine boundary layer. The breeze layer has a limited vertical extension and its relative contribution to the MAXDOAS long path is small. Secondly, it allows concentrations below the detection limit of in situ instrument to be retrieved.

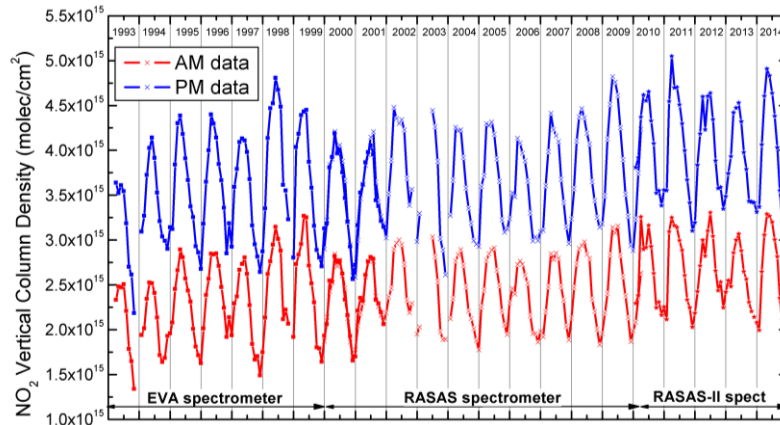

Figure 11.3. Time series of reanalyzed stratospheric NO₂.

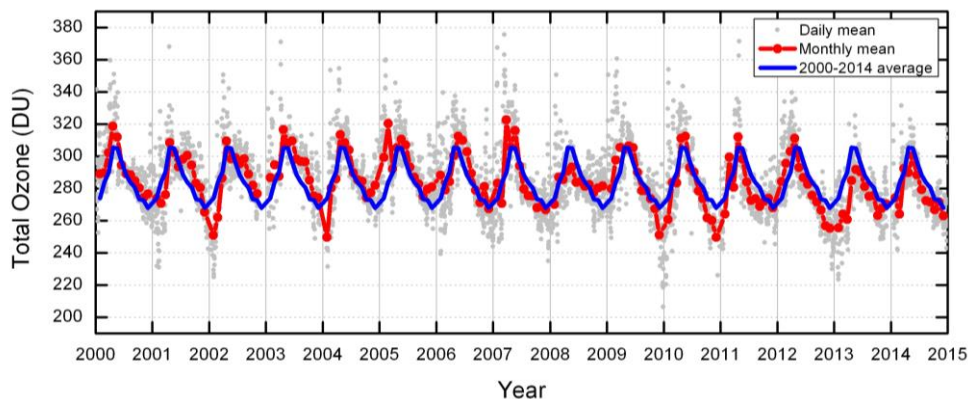

Figure 11.4. Time series of reanalyzed stratospheric O₃.

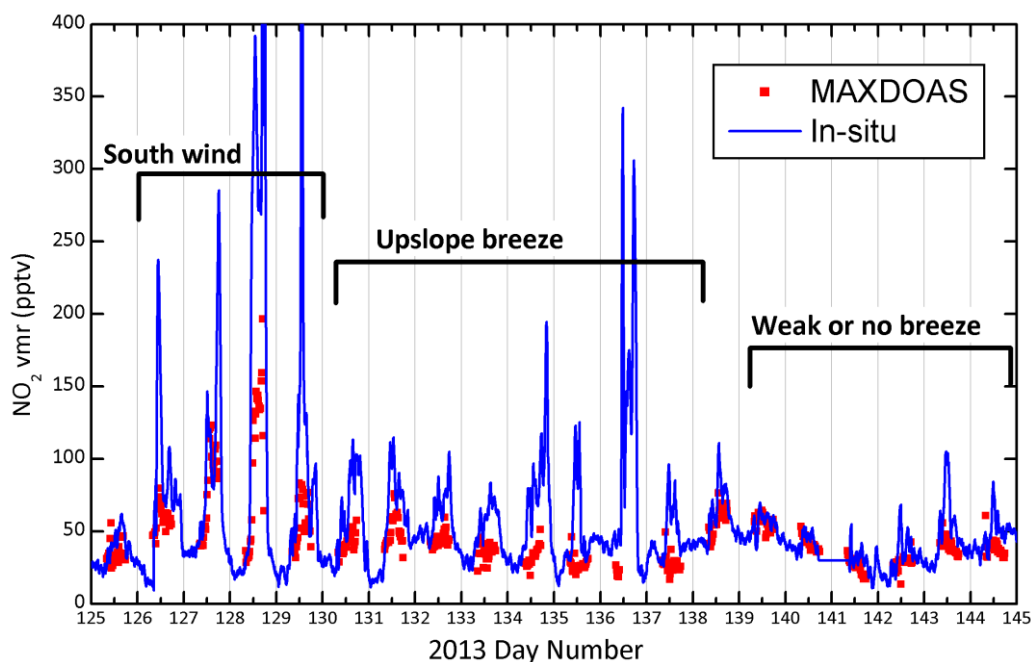

Figure 11.5. Izaña Atmospheric Observatory MAXDOAS versus minutal in-situ NO_2 volume mixing ratio for a period of time representative of three different wind regimes. Figure reprinted from Gil et al. (2015).

Results from Gil et al. (2015) illustrate the differences in concentration between the in-situ local sampling and the MAXDOAS long-path average (Fig. 11.5). On days when the breeze is inhibited, the in-situ data are representative of the free troposphere, and the agreement between instruments is very good (days 139-145). On days when anabatic winds are present, NO_2 volume mixing ratio increases are observed in in-situ data whereas the MAXDOAS signal remains at FT levels (days 130-137). The upslope wind counteracts the subtropical subsidence and the intensity can be very variable. In general, the depth of the layer is not enough to contaminate the MAXDOAS path. This situation is the one most commonly observed at IZO. A third set of measurements is shown when MAXDOAS data also show large increases in NO_2 (days 127-129) originating from a 980 MW thermal power plant located 25 km south of IZO.

11.4 Participation in Scientific Projects and Campaigns/Experiments

11.4.1 Network of Remote Sensing Ground Based Observations in support of the Copernicus Atmospheric Service (NORS)

UV-VIS DOAS spectrographs have been participating in the NORS project, a research project funded from the European Community's Seventh Framework Programme (FP7/2007-2013). NORS demonstrated the value of ground-based remote sensing data from the NDACC network for quality assessment and improvement of the Copernicus Atmospheric Service products. With this purpose,

improvements in data homogenization, data formatting and intercomparisons have been made to achieve highest data quality. In the framework of the NORS project, the NO_2 and O_3 stratospheric data series have been reanalysed and also a homogenization of the data analysis has been carried out for all groups belonging to UVVis-NDACC group. Nowadays, a recommendation from NDACC for analysis of NO_2 and O_3 using DOAS has been stated.

11.4.2 Atmospheric Minor Species relevant to the Ozone Chemistry at both sides of the Subtropical jet (AMISOC)

The AMISOC project principal objective was to improve the knowledge of the minor constituents in the atmosphere playing a role in the ozone chemistry. The core of the project was a coordinated campaign held in Tenerife (AMISOC TRF) in July 2013 involving multiple instrumentation, namely in situ, ground-based or from INTA aircraft. DOAS spectrographs for stratospheric NO_2 and O_3 , MAXDOAS for vertical distribution of minor species with major emphasis in reactive halogens (BrO and IO) and ultrafine particles nucleation processes, but also taking into consideration some pollutants such as formaldehyde and Glyoxal.

The island of Tenerife experiences periods of pristine atmosphere alternating with episodes of large Saharan dust loading which allows us to explore the interaction between the afore-mentioned species and desert dust. Moreover, boundary layer, free troposphere and in situ observations were simultaneously performed allowing the characterization of the vertical impact of Saharan dust on

the behaviour of the target gases at the same time. To ensure the quality of the data, an intercomparison campaign between all AMISOC DOAS-based instrumentation was performed at IZO prior to the AMISOC TRF campaign.

11.5 References

- Gil, M., M. Yela, E. Cuevas and V. Carreño, Sudden increases in the NO₂ column caused by thunderstorms: A case study in the northern subtropical region. *Atmospheric Chemistry and Physics Discussions*, 4, 2263-2281, 2004.
- Gil, M., M. Yela, L. N. Gunn, A. Richter, I. Alonso, M. P. Chipperfield, E. Cuevas, J. Iglesias, M. Navarro, O. Puentedura, and S. Rodriguez, NO₂ climatology in the northern subtropical region: diurnal, seasonal and interannual variability *Atmos. Chem. Phys.* 8, 1635–1648, 2008.
- Gil-Ojeda, M., M. Navarro-Comas, A. Redondas, O. Puentedura, F. Hendrick, M. Van Roozendaal, J. Iglesias and E. Cuevas. Título: Total ozone measurements from the NDACC Izaña Subtropical Station: Visible spectroscopy versus Brewer and satellite instruments. Quadrennial Ozone Symposium, (QOS 2012). Toronto, Canada. 27-31 August 2012.
- Gil-Ojeda, M., M. Navarro-Comas, L. Gómez-Martín, J.A. Adame, A. Saiz-López, C. Cuevas, Y. González, O. Puentedura, E. Cuevas, J-F Lamarque, D. Kinninson and S. Tilmes, NO₂ seasonal evolution in the North Subtropical free troposphere, *Atmos. Chem. Phys. Discuss*, 15, 14473–14504, doi:10.5194/acpd-15-14473-2015, 2015.
- Gomez, L., Navarro-Comas, M., Puentedura, O., Gonzalez, Y., Cuevas, E., and Gil-Ojeda, M.: Long-path averaged mixing ratios of O₃ and NO₂ in the free troposphere from mountain MAX-DOAS, *Atmos. Meas. Tech.*, 7, 3373-3386, doi:10.5194/amt-7-3373-2014, 2014.
- Hendrick, F., J.-P. Pommereau, F. Goutail, R. D. Evans, D. Ionov, A. Pazmino, E. Kyrö, G. Held, P. Eriksen, V. Dorokhov, M. Gil, and M. Van Roozendaal, NDACC/SAOZ UV-visible total ozone measurements: improved retrieval and comparison with correlative ground-based and satellite observations, *Atmos. Chem. Phys.*, 11, 5975-5995, 2011.
- Lambert, J.-C., Granville, J., Lerot, C., Hendrick, F., Van Roozendaal, M., Andersen, S.B., Dorokhov, V., Gerard, P., Gil, M., Goutail, F., Gruzdev, A.N., Held, G., Ionov, D.V., Johnston, P.V., Kostadinov, I., Kreher, K., Kyrö, E.I., Leveau, J., Navarro-Comas, M., Petritoli, A.j , Pommereau, J.-P., Richter, A., Roscoe, H.K., Semenov, V.K., Stebel, K., Vaughan, G., Wagner, T., Wittrock, F., Yela, M. GDP 4.0 transfer to SGP 3.0 for SCIAMACHY no2 column processing: Verification with SDOAS / GDOAS prototype algorithms and delta-validation with NDACC / UV-visible network data. European Space Agency, (Special Publication) ESA SP, (SP-642), 8 p., ISBN: 9290922060; 9789290922063. 2007.
- Meijer, Y.J., D.P.J. Swart, R. Koelemeijer, M. Allaart, S. Andersen, G. Bodeker, I. Boyd, G. Braathen, Y. Calisesi, H. Claude, V. Dorokhov, P. Von der Gateen, M. Gil, S. Godin-Beekmann, F. Goutail, G. Hansen, A. Karpetchko, P. Keckhut, H. Kelder, B. Kois, R. Koopman, J.-C. Lambert, T. Leblanc, I.S. McDermid, S. Pal, U. Raffalski, H. Schets, R. Stubi, T. Suortti, G. Visconti and M. Yela., Pole-to-Pole validation of ENVISAT/GOMOS ozone profile using data from ground-based and balloon measurements, 109, D23305, doi: 10.1029/2004JD004834, *J.Geophys. Res.-Atmospheres*, 2004.
- Platt and Stutz, *Differential Optical Absorption Spectroscopy, Principles and Applications*, Springer, 2008.
- Pinardi, G., Van Roozendaal, M., Abuhassan, N., Adams, C., Cede, A., Clémer, K., Fayt, C., Frieb, U., Gil, M., Herman, J., Hermans, C., Hendrick, F., Irie, H., Merlaud, A., Navarro Comas, M., Peters, E., Pipers, A. J. M., Puentedura, O., Richter, A., Schönhardt, A., Shaiganfar, R., Spinei, E., Strong, K., Takashima, H., Vrekoussis, M., Wagner, T., Wittrock, F., and Yilmaz, S.: Erratum: MAX-DOAS formaldehyde slant column measurements during CINDI: intercomparison and analysis improvement (*Atmospheric Measurement Techniques* (2013) 6 (167-185)), *Atmos. Meas. Tech.*, 6 (2), 219, doi: 10.5194/amt-6-219-2013, 2013.
- Pipers, A. J. M., Boersma, K. F., et al.: The Cabauw Intercomparison campaign for Nitrogen Dioxide measuring Instruments (CINDI): design, execution, and early results, *Atmos. Meas. Tech.*, 5, 457-485, doi:10.5194/amt-5-457-2012, 2012.
- Puentedura, O., Detección remota de monóxido de bromo en la atmósfera subtropical mediante espectroscopía de absorción diferencial. Tesis Doctoral, Universidad Complutense de Madrid, 2004.
- Puentedura, O., Gil, M., Saiz-Lopez, A., Hay, T., Navarro-Comas, M., Gómez-Pelaez, A., Cuevas, E., Iglesias, J., and Gomez, L.: Iodine monoxide in the north subtropical free troposphere, *Atmos. Chem. Phys.*, 12, 4909-4921, doi:10.5194/acp-12-4909-2012, 2012.
- Roscoe, H. K., Van Roozendaal, M., Fayt, C., du Piesanie, A., Abuhassan, N., Adams, C., Akrami, M., Cede, A., Chong, J., Clémer, K., Friess, U., Gil Ojeda, M., Goutail, F., Graves, R., Griesfeller, A., Grossmann, K., Hemerijckx, G., Hendrick, F., Herman, J., Hermans, C., Irie, H., Johnston, P. V., Kanaya, Y., Kreher, K., Leigh, R., Merlaud, A., Mount, G. H., Navarro, M., Oetjen, H., Pazmino, A., Perez-Camacho, M., Peters, E., Pinardi, G., Puentedura, O., Richter, A., Schönhardt, A., Shaiganfar, R., Spinei, E., Strong, K., Takashima, H., Vlemmix, T., Vrekoussis, M., Wagner, T., Wittrock, F., Yela, M., Yilmaz, S., Boersma, F., Hains, J., Kroon, M., Pipers, A., and Kim, Y. J.: Intercomparison of slant column measurements of NO₂ and O₄ by MAX-DOAS and zenith-sky UV and visible spectrometers, *Atmos. Meas. Tech.*, 3, 1629-1646, doi:10.5194/amt-3-1629-2010, 2010.
- Rodgers, C.D., *Inverse methods for Atmospheric Sounding: Theory and Practice*, World Scientific, Series on Atmospheric, Oceanic and Planetary Physics, Vol. 2, 2000.

11.6 Staff

The DOAS research group is composed of researchers and specialist technicians from INTA and IARC-AEMET.

Dr Manuel Gil Ojeda (INTA; Head of programme)

Dr Laura Gómez Martín (INTA; Research Scientist)

Javier Iglesias Méndez, (INTA; Research Scientist)

Mónica Navarro Comas (INTA; Research Scientist)

Dr Olga Puentedura Rodríguez (INTA; Research Scientist)

Dr Margarita Yela González (INTA; Research Scientist)

Ramón Ramos (AEMET; Head of Infrastructure)

12 Water Vapour

12.1 Main Scientific Goals

The main scientific goals of this programme are:

- Monitoring and study of precipitable water vapour (PWV) total column content and vertical profile.
- Analysis of daily, seasonal and annual cycles of PWV for different air masses.
- Study of radiative forcing due to water vapour and clouds.
- Tests of low-cost IR sensors for PWV and cloud height estimation.

12.2 Measurement Programme

In this programme several measurement techniques are used.

12.2.1 RS-92 radiosondes

From the vertical profiles of relative humidity obtained with RS-92 radiosondes, precipitable water content in the atmospheric column is calculated by integrating numerically (using the trapezoidal rule) the density function of atmospheric water vapour for the base and top of each atmospheric stratum. The integration is performed from ground level to 12 km altitude. By default, the PWV profile is supplied for the following layers: 1) from ground up to 1.5 km; 2) from 1.5 km to 3 km altitude in layers of 0.5 km thickness; 3) from 3 km altitude up to 12 km in layers of 1 km thickness.

12.2.2 Radiometric technique

Precipitable total water content in the atmospheric column is estimated from the absorption of water vapour in narrow band around 941nm. From PWV value deduced from RS92, we can characterize, on the one hand, the filter parameters of the water vapour channel using the Campanelli technique (Campanelli et al, 2010; Romero- Campos et al., 2011), and on the other hand, through the Langley-modified technique, we can obtain the extraterrestrial irradiances for 941 nm, from which we extract the corresponding calibration constant. Finally, 1-minute PWV is obtained.

12.2.3 Global Navigation Satellite System technique

The Global Navigation Satellite System (GNSS) technique consists in determination of PWV in the atmospheric column from the observed delay in radio signals at two different frequencies emitted by a network of Global Positioning System (GPS) and Global Navigation Satellite System (GLONASS) satellites received in our GNSS receiver (Fig. 12.1). Atmospheric pressure in places where the GNSS antennas are located is a key parameter for obtaining the PWV from the zenith total delay (ZTD) and zenith hydrostatic delay (ZHD).



Figure 12.1. Global Navigation Satellite System receiver at Izaña Atmospheric Observatory.

Currently, we work with eight GNSS stations (Fig. 12.2) at different heights, seven of them on the island of Tenerife and one on the island of La Palma. The main four GNSS stations with accurate surface pressure records (from reference meteorological stations) are: Reina Sofia Airport-Tenerife South; IZO; SCO and La Palma Airport. The GNSS network and data acquisition are managed by the Spanish National Geographic Institute (IGN).

The ZTD calculation from GNSS signals for both ultra-rapid orbits and precise orbits is performed by the IGN using Bernese 5.0 software. The PWV is calculated at IZO from ZTD and pressure values at the stations. An important task we do is estimate the pressure in the GNSS sites where measurements of surface pressure are not available. To do this, we calculate, based on the hydrostatic equation, a mean density (weighted by gravity) of the air in the air column between the nearest reference weather stations and our GNSS station located at different altitude on the field.

The final evaluation of the PWV obtained by the three techniques described above is performed by comparing the results with each other. At IZO these techniques have been evaluated using the FTIR as reference instrument. A detailed analysis is provided in Schneider et al. (2010).

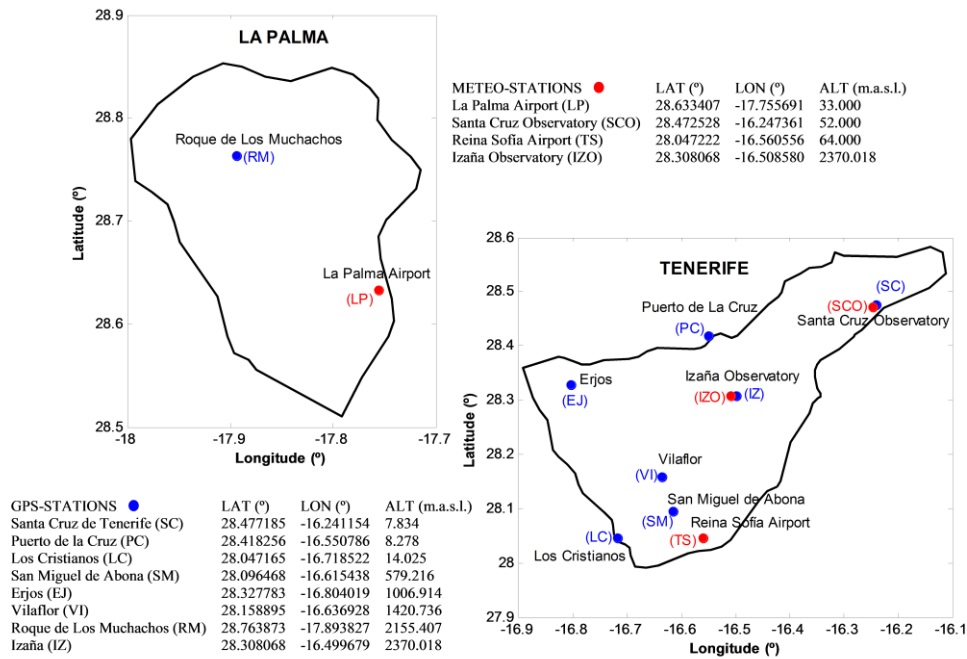

Figure 12.2. Locations of Global Navigation Satellite System stations.

12.3 Summary of remarkable results during the period 2012-2014

12.3.1 Daily cycle of PWV from GNSS

The averaged daily cycles of PWV for the period 2008-2014 are shown for GNSS stations at SCO and at IZO (Fig. 12.3). The daily cycles have been calculated from averaged hourly anomalies. For these statistics, we have selected only those hourly average values with, at least, three high quality intra-hours values. The daily time anomalies were obtained by subtracting from the value of the corresponding hourly average, the value of the total daily average. For each hour, there were available more than 60% of the possible data anomalies within the time period of evaluation. The diurnal variation is quite similar at IZO and SCO, and a minimum is observed at around 10UTC at these stations.

12.3.2 PWV data series from GNSS

Daily PWV derived from ZTD calculated for ultra-rapid GPS orbits on days in which we have, at least, 60% of all fifteen-minute values are shown in Fig. 12.4. These series correspond to IZO and SCO for the period 2008-2014. Gaps are caused by no ZTD data. The maximum values are observed in summer-autumn and the minimum values in winter.

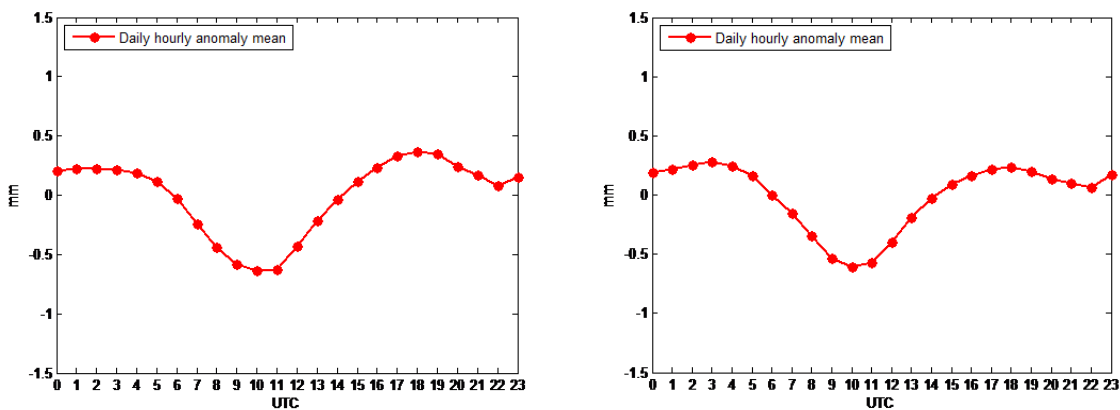

Figure 12.3. PWV daily cycles at SCO (left) and IZO (right).

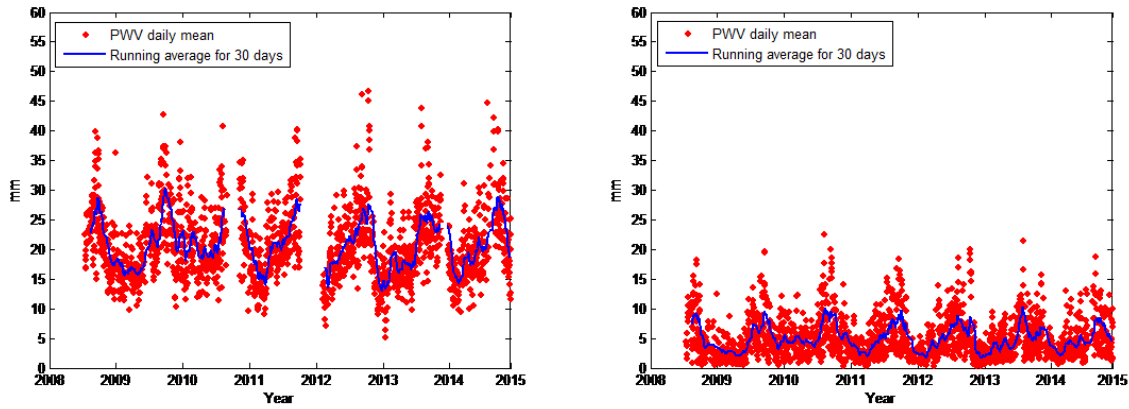

Figure 12.4. PWV series at SCO (left) and IZO (right) for 2008–2014.

12.3.3 Daily PWV from radiosondes at Tenerife

Relatively long PWV data series are available from the radiosondes launched on Tenerife. PWV calculated from radiosondes at SCO and IZO are shown for the period 1994–2014 (Fig. 12.5). These are the values of PWV calculated over the duration of the radiosonde flight (about 2 hours or so) from the time of its release, and assuming that, in this period of time, the PWV remains constant. We can observe annual cycles with peaks in summer-autumn and minimum values in winter. Lower values of PWV are observed at IZO in comparison with SCO.

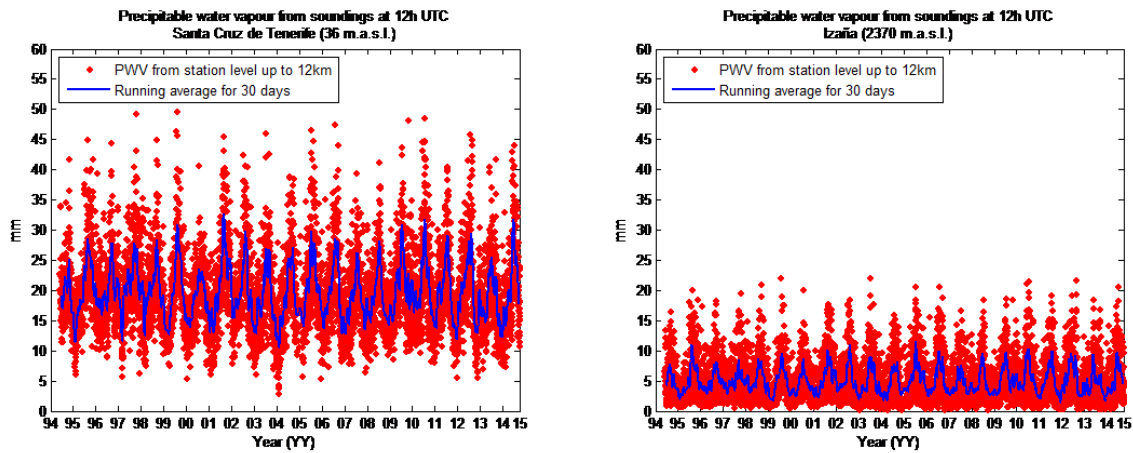

Figure 12.5. Daily PWV series from Tenerife radiosondes for SCO and IZO (1994–2014).

12.3.4 PWV vertical stratification monthly statistics

The monthly average of PWV vertical distribution over Tenerife, obtained from radiosondes data at 0 and 12UTC in the period 1994–2014, are depicted in Fig. 12.6. No significant differences are found between 00 and 12UTC. Most of the PWV is concentrated within the first 1.5 km altitude. There is a wet season from August to October, with a maximum in September, and a "dry" season that corresponds to the months from January to April with a

minimum in February–March. The total height of each column corresponds to the total monthly averaged PWV at sea level. The minimum monthly averaged PWV is about 15mm in February while the maximum (27mm, approximately) is recorded in September.

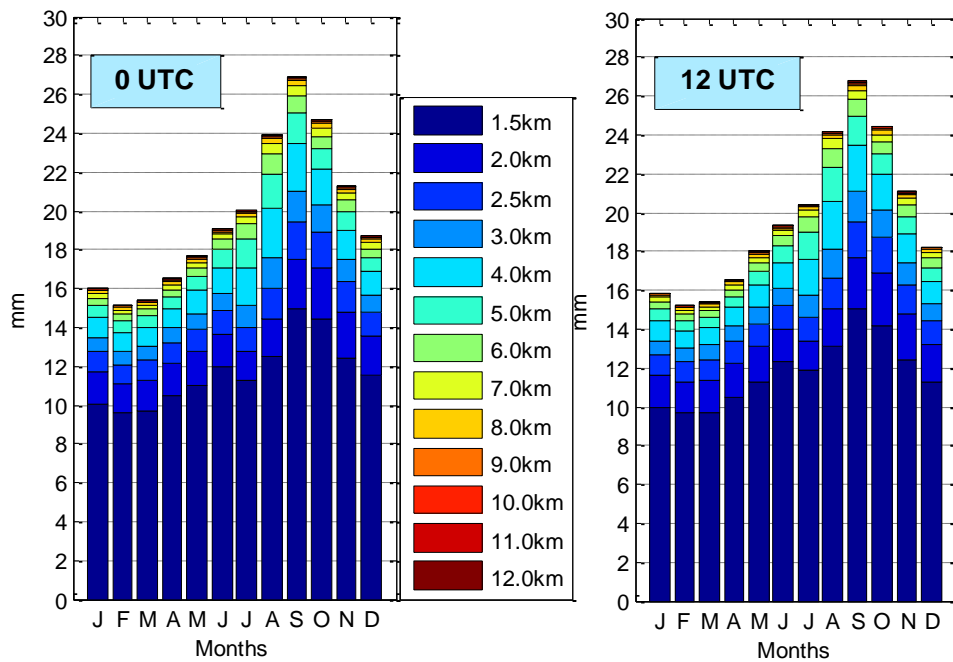

Figure 12.6. Monthly statistics of precipitable water vapour vertical distribution from radiosondes at Tenerife (1994-2014).

12.4 Participation in Scientific Projects and Campaigns/Experiments

12.4.1 First results with the Sky Temperature Sensor (STS) prototype

The infrared thermometer Sky Temperature Sensor (STS), developed by SIELTEC Canarias, measures infrared radiation from zenith sky in the spectral range between 5.5 μm and 15.0 μm . The field of view (FOV) is 5° and it is capable of measuring a temperature down to -70 °C.

The radiometer was initially calibrated on August 11, 2014 with a black body cavity blackened aluminium (Land infrared Dronfield Sheffield, P80P type, serial number: 271775-1) from the University of La Laguna. For calibration, a high-precision temperature sonde (Fluke Hart Scientific Division, t-90 type, model 1502A, BOC677 serial number) owned by the University of La Laguna was used.

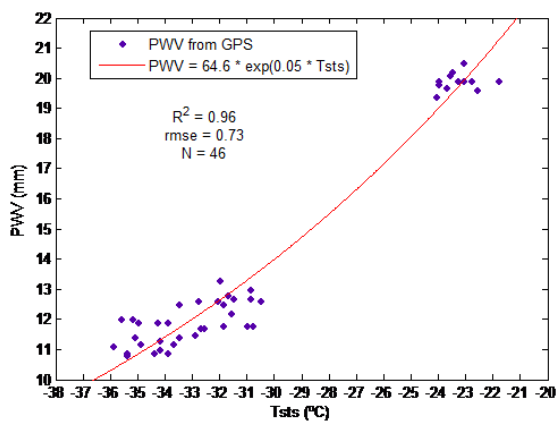

Figure 12.7. Relationship between PWV from GPS and sky temperature from STS for clear skies over SCO.

The goal of this radiometer is twofold: firstly, to estimate the amount of PWV over SCO under clear skies (Fig. 12.7) and, secondly, to determine the height of the base of medium and low clouds for overcast skies (Fig. 12.8).

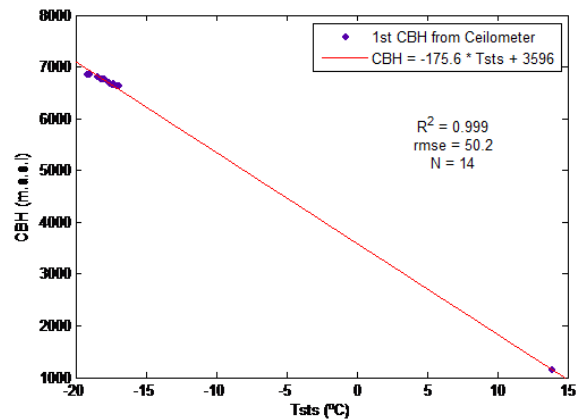

Figure 12.8. Relationship between the cloud-base height (CBH) measured with the ceilometer VL-51 and sky temperature from STS for overcast skies over SCO.

12.5 References

- Campanelli, M., A. Lupi, T. Nakajima, V. Malvestuto, C. Tomasi and V. Estellés (2010). Summertime columnar content of atmospheric water vapor from ground-based Sun-sky radiometer measurements through a new in situ procedure. *J. Geophys. Res.*, 115, D19304, doi: 10.1029/2009JD013211.
- Romero Campos, P.M., Emilio Cuevas Agulló, Omaira García Rodríguez, Alberto J. Berjón Arroyo y Victoria E. Cachorro Revilla.: Aplicación de la Técnica de Campanelli para la calibración de los canales de vapor de agua de fotómetros CIMEL en el Observatorio Atmosférico de Izaña. NTD n° 2.

NIPO: 784-11-010-6. Centro de Investigación Atmosférica de Izaña. Agencia Estatal de Meteorología (España). 2011.

Schneider, M., Romero, P. M., Hase, F., Blumenstock, T., Cuevas, E., and Ramos, R.: Continuous quality assessment of atmospheric water vapour measurement techniques: FTIR, Cimel, MFRSR, GPS, and Vaisala RS92, *Atmos. Meas. Tech.*, 3, 323-338, doi:10.5194/amt-3-323-2010, 2010.

12.6 Staff

Pedro Miguel Romero Campos (AEMET; Head of programme)

Ramón Ramos (AEMET; Head of Infrastructure)

César López Solano (SIELTEC)

13 Meteorology

13.1 Main Scientific Goals

The main goals of this programme are:

- To maintain meteorological parameter observations according to WMO specifications, and in the framework of AEMET's Synoptic and Climatological Observation networks.
- To measure conventional meteorological parameters at different stations on the island of Tenerife, to support other observation programmes.
- To develop other non-conventional meteorological parameters programmes.
- To provide meteorological analysis information to document and support results from other observation programmes and scientific projects.
- To provide diagnosis and operational weather forecasting to support routine operation activities at the IARC observatories and issue internal severe weather alerts and special forecasts for planned field campaigns, outdoor calibrations, repairs, etc.

13.2 Measurement Programme

The Izaña Atmospheric Research Center directly manages six weather observation stations located at IZO, SCO, BTO and TPO (see Section 3 for more details of the IARC facilities).

Izaña Atmospheric Observatory

IZO has three fully automatic weather stations, two of them located in the weather garden (C430E/60010 and Meteo-STD), which include a network of five cloud observation webcams, and the third one on the instrument terrace of the observation tower (Meteo-Tower) at 30 m above ground level. Instrumentation for manual observation (staffed by personnel) with temperature, humidity, pressure and precipitation analog recorders (bands), is also maintained at

IZO in order to preserve the historical series that have been measured at Izaña Atmospheric Observatory since 1916.

Santa Cruz Observatory

SCO has a fully automatic weather station located on the instrument terrace.

Botanic Observatory

BTO has a fully automatic weather station installed at the ozonesounding station at the Botanic Garden in Puerto de la Cruz.

Teide Peak Observatory

TPO has an automatic very high altitude weather station with temperature, humidity and pressure sensors, supplemented with data from a wind sensor installed at the Cable Car tower No.4, managed by the Cable car company.

The meteorology programme also has access to meteorological soundings data of pressure, temperature, humidity and wind from the Tenerife station (Id: WMO 60018) located in the town of Güimar, belonging to AEMET's upper-air observation network, and managed by the Meteorological Center of Santa Cruz de Tenerife (AEMET).

13.3 Meteorological Resources

To accomplish the objectives of this programme we have the following tools:

Man Computer Interactive Data Access System (McIDAS)

LINUX Workstations (Fedora Core) with the Man Computer Interactive Data Access System (McIDAS) application provide access, exploitation and visualization of meteorological information from different geo-referenced observations, modelling and remote sensing (satellite, radar) platforms.

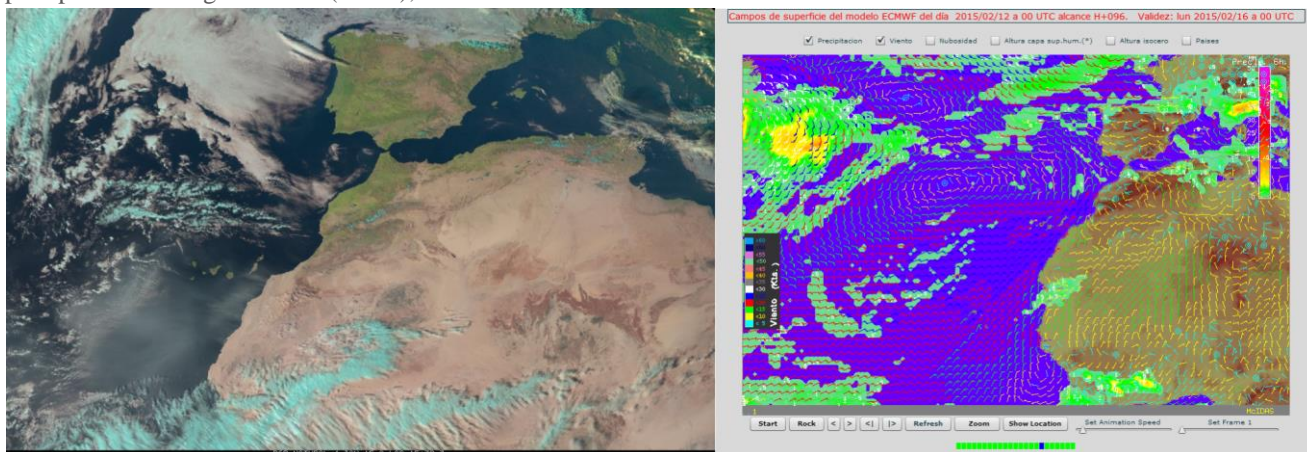

Figure 13.1. Left: natural RGB composite image with the (R) channel 1 (B), 2 (G) and 3 satellite Meteosat-10 (MSG-3) for 4/1/2015 15:30 UTC. Right: graphical output of the predicted fields to 96 h, of the ECMWF IFS model for surface wind (coloured barbs) and precipitation in 6 h (filled in colour) for 16/02/2015 00 UTC.

The application provides accessibility to all data in real time in the AEMET National Prediction System, including the following data and products:

- Global synoptic surface observation and upper-air networks.
- Outputs of numerical prediction models from ECMWF (IFS) and AEMET (HIRLAM).
- METEOSAT satellite imagery.
- Images of AEMET's Weather Radar Network.
- Data from AEMET's Electrical Discharge Detection network.
- Products derived from SAF (Satellite Application Facilities) Nowcasting MSG images.

Utilising this application different automated processes for the exploitation of this information [information listed above] have been developed, among which we can highlight:

1) Automatic generation of graphical products from specific models and images from derived MSG products (RGB combinations), for consultation through an internal website (see Fig. 13.1).

2) Calculation of isentropic back trajectories of air masses from analysis outputs (4 cycles per day) and prediction (every 12 hours and range up to 132 hours) for Tenerife and other places in the Canary Islands and the rest of Spain, at different vertical levels.



Figure 13.2. Screenshot of isentropic back-trajectories for several points of Spain with 96 h forecasted on day 15/02/2015 12 UTC at the level of 850 hPa.

3) Email and web-based lightning strikes warning and detection system near IZO, for taking preventive action to avoid damages in the facilities.

EUMETCast receiving system

The EUMETCast real-time receiving system for aerial imagery and meteorological satellite data distributed by EUMETSAT has its own internal web interface for displaying images received, and mass storage system for archiving images of compressed MSG segments in original format.

EUMETSAT Data Center

We have access to the EUMETSAT Data Center for retrieval of images and historical products of Meteosat satellites.

Non-hydrostatic high resolution weather model (MM5)

The meteorology programme has access to a clusters system in LINUX environment of parallel processors for the integration of a non-hydrostatic high resolution weather model (MM5) for the area of the Canary Islands. The initial and boundary conditions are provided by the ECMWF model IFS, and outputs are generated on three nested grids of 18, 6 and 2 km horizontal resolution with a time range up to 144 hours ahead. The outputs of this model offer the added value of dynamic downscaling of the IFS model predictions on the complex topography of the Canary Islands.

AEMET Server Meteorological Data System

Access to numerical models databases, observations, bulletins, satellite and radar images is available on the AEMET Server Meteorological Data System (SSDM).

ECMWF products and MARS archive

The meteorology programme has access to the European Centre for Medium-Range Weather Forecasts (ECMWF) computer systems and consultation of the Meteorological Archival and Retrieval System (MARS) archive of all operational products generated in this centre. From this system we have developed different exploitation processes such as:

- Routine extraction in two cycles per day of meteorological analysis and prediction fields of IFS model, which are decoded in a compatible format for exploitation from McIDAS, and for the integration of the high resolution model.
- Monthly extraction of ERA-Interim reanalysis outputs for updating large data series for different projects.
- Previous analysis fields calculation for computing back trajectories with FLEXTRA.

AEMET National Climatological Data Base (BDCN)

The meteorology programme has access to the AEMET National Climatological Data Base (BDCN) for data extraction of observations from the AEMET principal and secondary climatological networks.

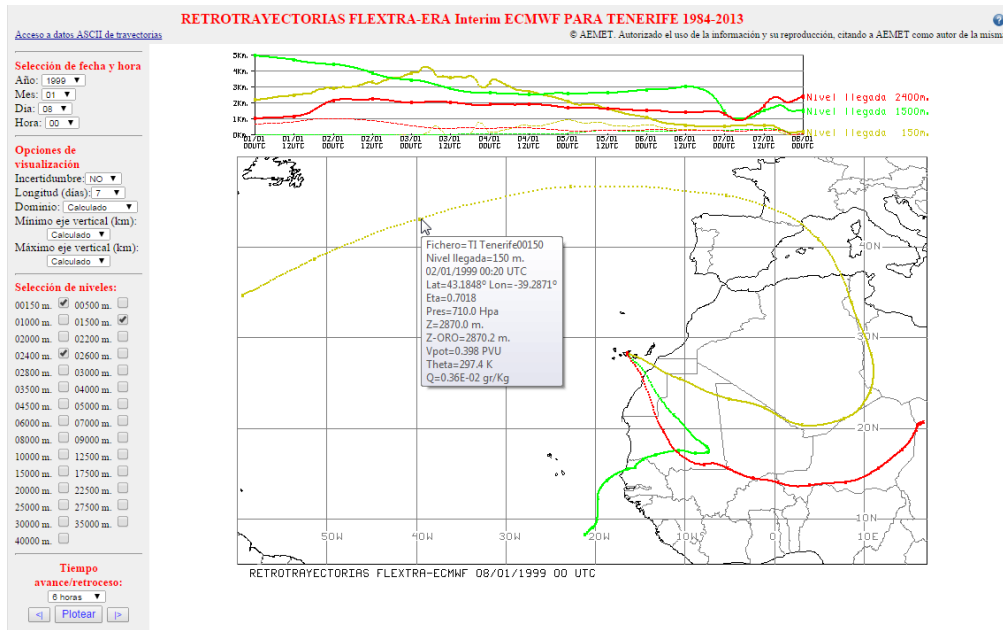

Figure 13.3. Screenshot of the interactive visualization intranet webpage, showing FLEXTRA backward trajectories ending over Tenerife (at 150, 1500 and 2400 m altitude), corresponding to the day 08/01/1999 at 00UTC.

13.4 Summary of activities during the period 2012-2014

Activities of this measurement programme during 2012-2014 include:

- 1) Maintenance of meteorological instrumentation to ensure quality and continuity of observations within national and international meteorological and climatological observation networks in which IZO participates. These include the Synoptic Observation Network (WMO Region I, ID: 60010), included in the surface observation network of Global Climate Observing System (GCOS), the AEMET Climatological Monitoring Network (ID C430E) and the Baseline Surface Radiation Network (BSRN; station # 61).
- 2) Supervising and quality checking of meteorological data from IZO, SCO, BTO and TPO.
- 3) Data recovery of historical climatological series from IZO (1916-1931).
- 4) Debugging and filling gaps of meteorological data to allow the reconstruction of complete meteorological datasets of nearly a century (since 1916). Data series analysis and homogenization for decadal variations and long-term trends determination.
- 5) Operational implementation of new observation programs such as disdrometers, 3D wind sensor and atmospheric electric field sensor.
- 6) Computation of a complete dataset of daily backward trajectories (at 00, 06, 12 and 18 UTC) at 29 vertical levels of the troposphere and stratosphere (from 150m to 40 km altitude), ending at Tenerife, with a length of 10 days, from 1984 to present. These trajectories are calculated from

ECMWF ERA-Interim reanalysis with a resolution of 1° latitude / longitude over the northern hemisphere as input to FLEXTRA Lagrangian dispersion model. The project includes a web-based interactive visualization system (Fig. 13.3).

7) Study of regionalized wildfire risk indexes for the Canary Islands from wildfire observational records and their correlation with numerical models data (ECMWF and Harmonie).

8) Analysis and prediction of severe weather events that may affect operations of the observation programs at the four IARC observatories. Special attention is paid to IZO, which is frequently affected by adverse events such as very strong winds, rain and heavy snow, lightnings, frost, and frozen rime, which can cause significant damages to facilities. The period 2012-2014 has been very rich in adverse phenomena. We highlight some of the most important episodes:

- From 12 to 16 February 2012, there was a storm with negative temperatures almost uninterrupted during the five days, with a minimum of -7.2°C on 14 February.
- On 30 and 31 October 2012, there was a wind and rainstorm with maximum gusts of over 155 km/h and accumulation of precipitation of 46 mm in just over six hours.
- The precipitation collected at IZO in the hydrometeorological year 2011-2012 was 45.7 l/m². This period was the driest in the history of IZO, whose data records started in 1916. The low precipitation value collected is noteworthy, as it is almost half of the next driest year, 1998-1999 (79.9 l/m²), and it is only just over 10% of climatological annual precipitation (442.2 l/m²).

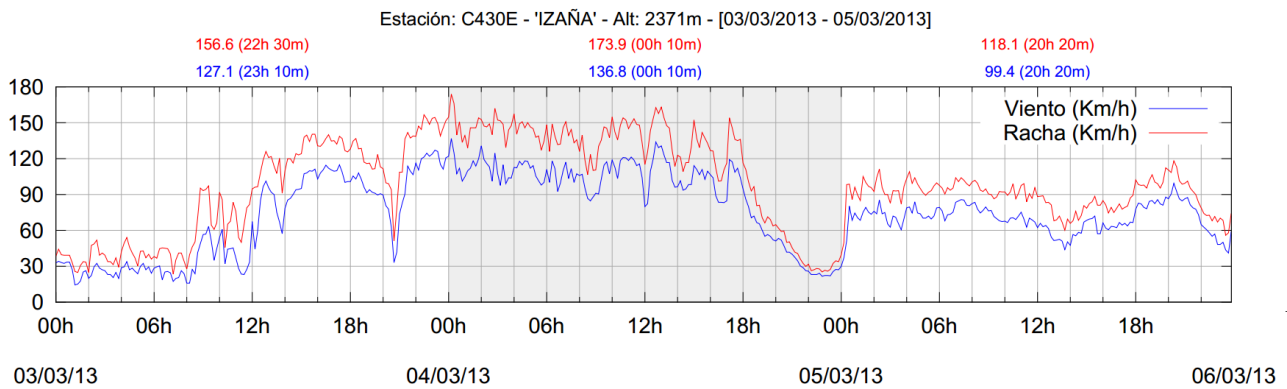

Figure 13.4. Representation of the mean velocity (blue line) and the maximum gust (red line) wind every 10' at the Izaña Atmospheric Observatory on days 3-5 March 2013. Chart produced by the Territorial Delegation of AEMET in the Canary Islands.

- On 3 and 4 March 2013 we recorded winds with average speeds sustained in 10 minutes above 100 km/h for nearly 24 hours continuously, with a maximum of up to 137 km/h, and maximum gusts that reached 174 km/h (Fig. 13.4), and a drop of atmospheric pressure to 741.8 hPa. You can view an article on this episode at this [link](#).
- On 11 and 12 December 2013 there was a rainstorm and heavy snow storms in which we recorded 87.6 mm in less than 24 hours, with numerous lightning strikes, a total of 740 electrical discharges detected within 30 km around IZO, some of which impacted directly on it, severely affecting communications and electrical installation (Fig. 13.5).

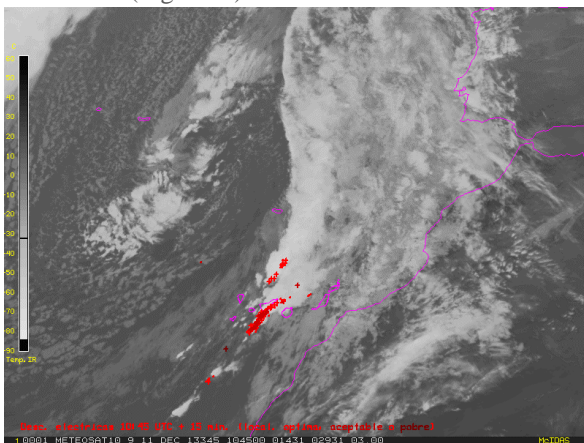

Figure 13.5. Plot of lightning detection in 15' (red dots) on Meteosat-10 IR image (channel 9 grayscale) for 11/12/2013 10:45 UTC.

- During 15 to 18 February 2014 we had a storm in which maximum wind gusts were recorded up to 142 km/h, temperatures below 0 °C for a total of 84 hours with a minimum of -4.3 °C, snow accumulation of 40 cm, strong rime ice with significant ice deposition on outdoor instrumentation, and lightning strikes, again affecting communications and data reception at IZO (Fig. 13.6). You can view an article on this episode at this [link](#).



Figure 13.6. Hard rime affecting IZO weather station after the storm from 15 to 18 February 2014. We can see the steel mast of one of the weather stations, broken in half (Photo: Rubén del Campo Hernández).

- On 18 and 19 April 2014 IZO there was a windstorm of short duration, but which reached a maximum wind gust of 176.8 km/h.
- On October 19 2014 there was a rainstorm with torrential shower intensity reaching a maximum of 72 mm/h (measured at 10'), accumulating more than 50 mm in 6 hours and gusting wind up to 115.9 km/h, and strong atmospheric electric discharges, this time successfully avoided by preventive measures.

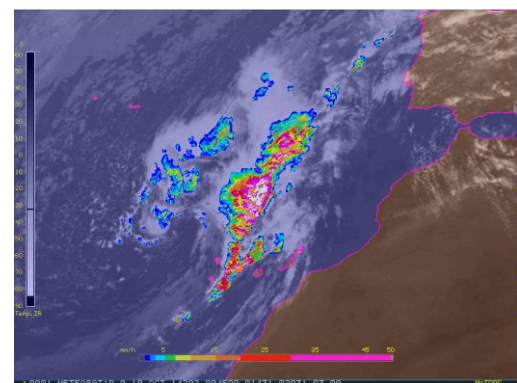

Figure 13.7. Intensity image Convective Rainfall Rate (CRR) from the Nowcasting SAF (fill colour) on IR image (channel 9) Meteosat-10 (brightness scale of land-sea mask) for 19/10/2014 9:45 UTC.

- On 22 and 23 November 2014 another storm occurred reaching maximum intensity of 43.2 mm/h persistent rain, accumulating a total of 192.4 mm in two days, and wind gusts of up to 136.4 km / h.
- On 28 and 29 November 2014 a rainstorm produced wind gusts of over 120 km/h for more than 24 hours, with a maximum of 175 km/h, and intense and persistent rainfall reaching 75 mm in 12 hours and a cumulative total of 98.6 mm throughout the episode.

13.5 Outstanding collaborations with other scientific programmes

Collaborations with other scientific programmes during 2012-2014 include the following:

- Extraction of climatological data of sunshine, clouds, visibility and meteors observed at IZO from the AEMET National Climatological Database, and advice on the interpretation of these data for recovery of historical solar radiation data (García et al., 2014).
- Extraction and upgrading of meteorological data over Tenerife from isobaric levels fields (from surface to 0.1 hPa) from operational models and ECMWF ERA-Interim reanalysis since 1990 in order to obtain vertical profiles of the atmosphere for the analysis of the vertical stability of the atmosphere and its implication in the atmospheric water vapour isotopes cycle (FTIR Programme).
- Extraction of hourly temperature and specific humidity data over Tenerife from isobaric levels fields (from 1000-1 hPa) of the operational ECMWF model to obtain data for the Water Vapour Programme.
- Extraction of monthly averaged zonal wind fields at isobaric levels (500-20 hPa) from the ECMWF ERA-

Interim reanalysis, from November 1994 to December 2011, for a study of the polar and subtropical jet streams positions over the North Atlantic and their relation to the height of the tropopause (Rodriguez-Franco and Cuevas, 2013).

- Analysis of dust events at GAW Tamanrasset Observatory (Algeria) from MSG satellite images and ECMWF IFS model fields for interpreting CIMEL radiation and column aerosols data (Guirado et al., 2014).
- Advice and weather forecasting for special and intensive aircraft observation campaigns:
 - 1) MUSICA and AMISOC campaigns, July 2013.
 - 2) PLASMA campaigns, March and July 2014.

13.6 Summary of remarkable results during the period 2012-2014

Among the results obtained in the years 2012-2014 we highlight the upgrade and reconstruction of long climate series of monthly mean temperature and annual accumulated precipitation since 1916. This constitutes almost a century of meteorological data and is the oldest uninterrupted climate series in the Canary Islands. In the series of annual mean temperatures at IZO (Fig. 13.8) an increased linear trend is observed at a ratio of 1.47 °C per century, quite similar to the values of global warming trend. This series is especially relevant since the station is at altitude and is representative of conditions of quasi free troposphere. As for the series of total annual rainfall at IZO (Fig. 13.9), given the typical high inter-annual variability of the precipitation at IZO, in which cyclical variations are observed, we cannot conclude a significant statistical trend during this period.

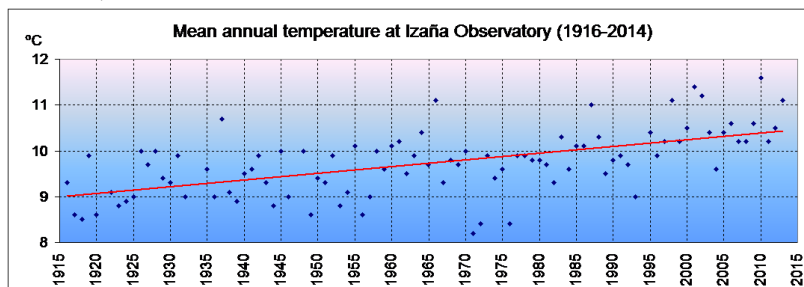

Figure 13.8. Time series (1916-2014) of annual average temperature at IZO (blue dots) with the line of linear regression trend (red line).

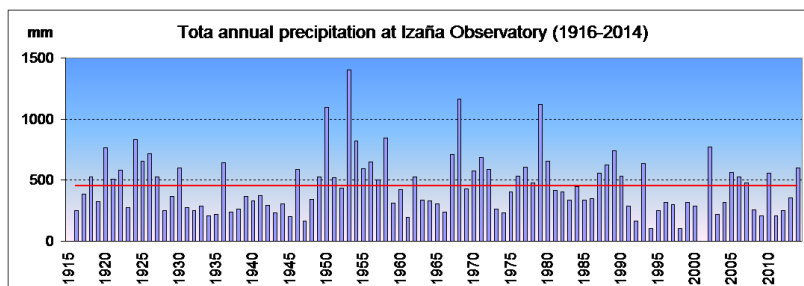

Figure 13.9. Time series (1916-2014) of total annual precipitation at IZO (blue bars) with the average (red line).

13.6.1 Izaña backtrajectories climatology

It is worth mentioning the statistics of back-trajectories arriving on the island of Tenerife at a height of 2400 m. between 1988 and 2009 (Cuevas et al., 2013). They were calculated with a length of 5 days and time step of 1 hour with the dispersion model HYSPLIT (version 4.0) with vertical component from vertical velocity model using meteorological fields FNL (Final Analysis Data) models until 2004 and GDAS (Global Data Assimilation System) thereafter, both from the National Centers for Environmental Prediction (NCEP) NOAA (Fig. 13.10).

The results provide relevant information on transport and source regions of air masses affecting the various components and parameters measured at IZO and their seasonal distribution throughout the year. A structure of polarized transport is observed throughout the year into two main source areas: first, the most important, of Atlantic origin, in which transport occurs from upper layers of the troposphere, with a minor contribution from western Europe, and the second on areas of North Africa and the Sahara desert, dominated by transport from lower layers and occurring more frequently during the summer.

13.6.2 Assessment of global warming on the island of Tenerife

Temperature variation was studied at different altitudes and orientation on the island of Tenerife, according to the trends in the mean, maximum and minimum at 21 AEMET stations. Reference series were obtained by sectors, along with a representative overall series for Tenerife, in which temperature shows a statistically significant growth trend of $+0.09 \pm 0.04^\circ\text{C}/\text{decade}$ since 1944. Night-time temperatures have risen most ($0.17^\circ\text{C} \pm 0.04^\circ\text{C}/\text{decade}$), while by day they have been more stable. Consequently, the diurnal temperature range between day and night has narrowed (Fig. 13.11).

By regions, warming has been much more intense in the high mountains than the other sectors below the inversion layer between 600 and 1,400 m altitude, and progressively milder towards the coast. The temperature rise on the windward (north-northeast) slopes is greater than on the leeward side and could be related to the increase in cloudiness on the northern side. The general warming of the island is less than in continental areas between 24 and 44°N , being closer to the sea surface temperature in the same area. This is probably explained largely by the insular conditions. In fact warming is more evident in the high mountains ($0.14 \pm 0.07^\circ\text{C}/\text{decade}$), where the tempering effect of the ocean and the impact of changes in the stratocumulus is weaker, being similar to the mean continental values in the northern hemisphere. This is the first paper (Martín et al., 2012) assessing “global warming” in the Canary Islands.

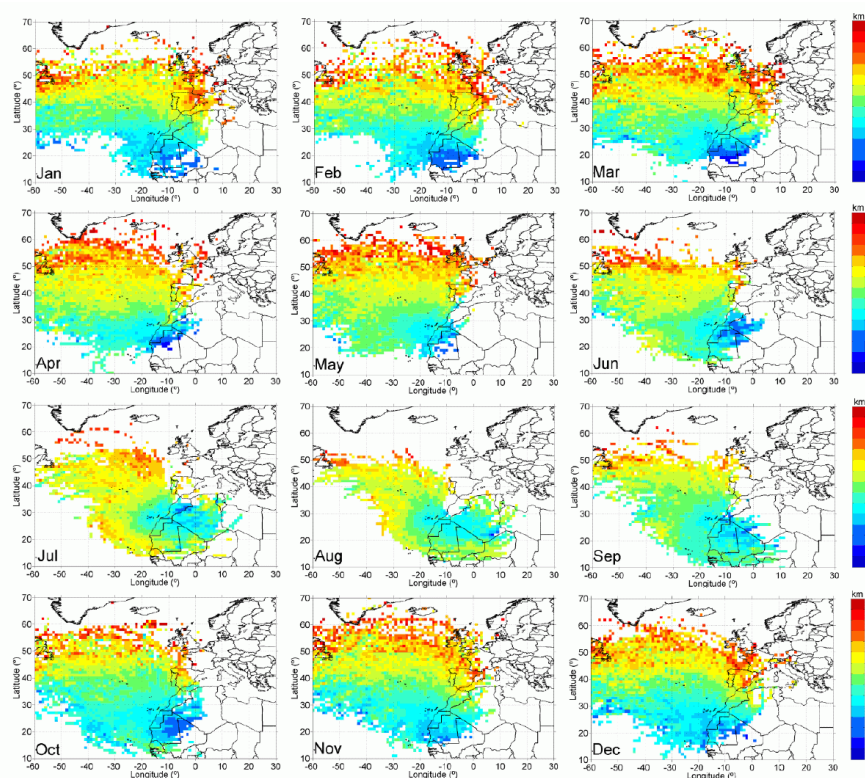

Figure 13.10. Backward trajectory mean height plots for each month of the year for the period 1988–2009. Colour bars indicate height in kilometres. Reprinted from Cuevas et al. (2013).

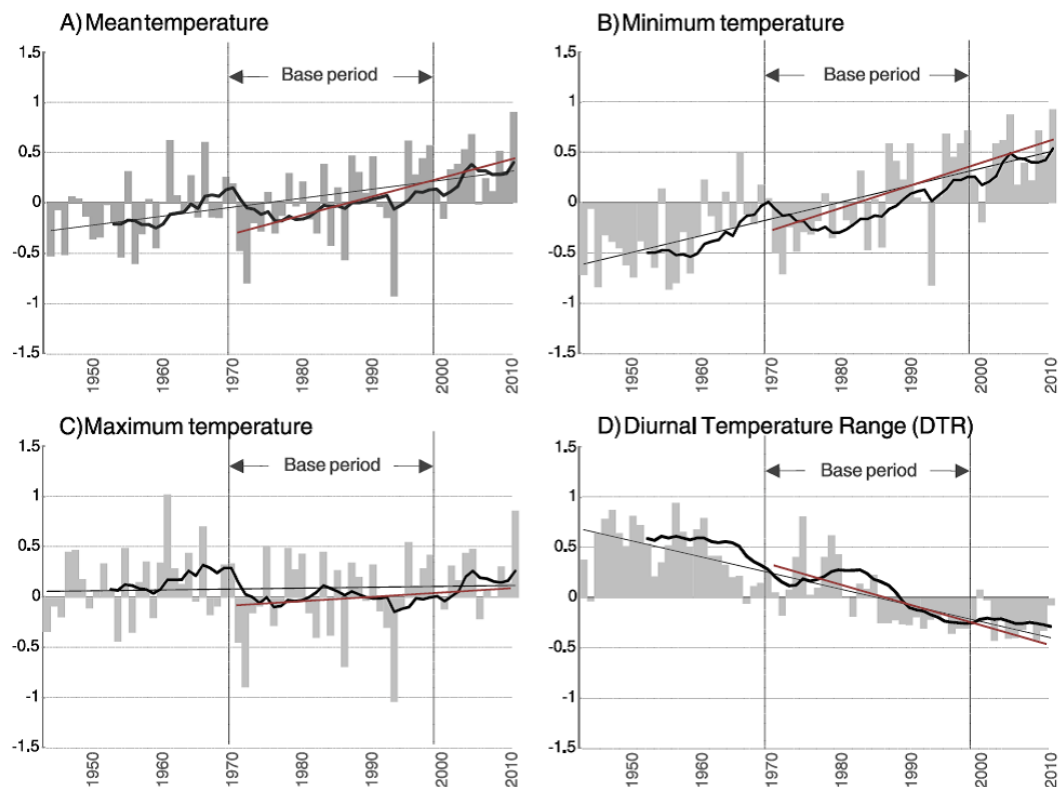

Figure 13.11. Trend in the evolution of mean, minimum and maximum annual anomalies in temperatures as well as annual diurnal temperature range anomalies on Tenerife. The curve represents the moving average factor 10, and the lines correspond to linear regressions for the periods 1944–2010 and 1970–2010, respectively. Reprinted from Martín et al. (2012).

13.7 References

- Cuevas, E., González, Y., Rodríguez, S., Guerra, J. C., Gómez-Peláez, A. J., Alonso-Pérez, S., Bustos, J., and Milford, C.: Assessment of atmospheric processes driving ozone variations in the subtropical North Atlantic free troposphere, *Atmos. Chem. Phys.*, 13, 1973-1998, doi:10.5194/acp-13-1973-2013, 2013.
- García, R. D., Cuevas, E., García, O. E., Cachorro, V. E., Pallé, P., Bustos, J. J., and de Frutos, A. M., Reconstruction of global solar radiation time series from 1933 to 2013 at the Izaña Atmospheric Observatory. *Atmospheric Measurement Techniques*, 7(9), 3139-3150, doi:10.5194/amt-7-3139-2014, 2014.
- Guirado, C., Cuevas, E., Cachorro, V. E., Toledano, C., Alonso-Pérez, S., Bustos, J. J., Basart, S., Romero, P. M., Camino, C., Mimouni, M., Zeudmi, L., Goloub, P., Baldasano, J. M., and de Frutos, A. M.: Aerosol characterization at the Saharan AERONET site Tamanrasset, *Atmos. Chem. Phys.*, 14, 11753-11773, doi:10.5194/acp-14-11753-2014, 2014.
- Martín, J.L., J.Bethencourt, and E. Cuevas-Agulló, Assessment of global warming on the island of Tenerife, Canary Islands (Spain). Trends in minimum, maximum and mean temperatures since 1944, *Climatic Change*, DOI 10.1007/s10584-012-0407-7, 2012.
- Rodríguez-Franco, J. J. and Cuevas, E., Characteristics of the subtropical tropopause region based on long-term highly-resolved sonde records over Tenerife, *J. Geophys. Res. Atmos.*, 118, doi:10.1002/jgrd.50839, 2013.

13.8 Staff

- Juan José Bustos (AEMET; Head of programme)
- Ramón Ramos (AEMET; Head of Infrastructure, Responsible for Meteorological Observation Programme)
- Cándida Hernández (AEMET; Meteorological Observer-GAW Technician)
- Rubén del Campo Hernández (AEMET; Meteorological Observer-GAW Technician)
- Concepción Bayo (AEMET; Meteorological Observer-GAW Technician)
- Virgilio Carreño (AEMET; Meteorological Observer-GAW Technician)
- Dr Fernando de Ory (AEMET; Meteorological Observer-GAW Technician)
- Sergio Afonso (AEMET; Meteorological Observer-GAW Technician)
- Dr Emilio Cuevas (AEMET; Research Scientist)
- Dr Rosa García (UVA/AEMET; Research Scientist)

14 Aerobiology

The Aerobiology programme at the IARC is carried out jointly by IARC-AEMET and the Laboratori d'Anàlisis Palinològiques (LAP) of the Universidad Autónoma de Barcelona (UAB) with partial financing from Air Liquide España S.A through the Eolo-PAT project. This programme started in 2004 at SCO with the aim of improving the knowledge of the pollen and spore content in the air of Santa Cruz de Tenerife and its relation with the prevalence of respiratory allergy. A second aerobiological station was implemented at IZO thanks to the financial support of the R+D National Plan CGL-2005-07543 project ("Origin, transport and deposition of African atmospheric aerosol in the Canaries and the Iberian Peninsula based on its Chemical and Aerobiological Characterization"). These two projects also contribute to improve the knowledge of the biological fraction of aerosols within the GAW program.

14.1 Main Scientific Goals

The main scientific goals of this programme are:

- To produce high quality standardized data on the biological component of the atmospheric aerosol.
- To establish the biodiversity and quantity of pollen and fungal spores registered in the air of Santa Cruz de Tenerife and Izaña.
- To establish the distribution pattern over the course of the year of the airborne pollen and fungal spores at Santa Cruz de Tenerife and Izaña, through the daily spectra.
- To put the Canary islands on the map of the global aerobiological panorama, along with the Spanish (REA; SEAIC) and European networks (EAN).
- To provide information useful for medical specialists and allergic patients.
- To set up the list of the allergenic pollen and spore taxa in the air of Santa Cruz de Tenerife and Izaña that will help doctors to diagnose the allergy aetiology and to rationalize the use of the medication.
- To produce weekly alerts on the allergenic pollen and spores for the days ahead to help doctors in the allergy detection and to help people suffering from allergies with a better planning of their activities and to improve the quality of their life.

A detailed description of this programme can be found in Belmonte et al. (2011).

14.2 Measurement Programme

The sampling instrument is a Hirst, 7-day recorder VPPS 2000 spore trap (Lanzoni S.r.l.) (Fig. 14.1) and the analysing instrument is a Light microscope, 600 X (Table 3.2). The pollen and spore analysis is conducted using palynological methods following the recommendations of the Spanish Aerobiology Network management and quality manual. The sampling programme at SCO is continuous through the year, whereas samples are only collected at IZO from April-May to November because of adverse meteorological conditions during the rest of the year.



Figure 14.1. Hirst, 7-day recorder VPPS 2000 spore trap at SCO (left) and at IZO (right).

14.3 Summary of remarkable results during the period 2012-2014

The annual dynamics of the total pollen and total fungal spores taxa in Santa Cruz de Tenerife and Izaña are shown in Figs. 14.2 and 14.3. Data shown correspond to mean weekly concentrations.

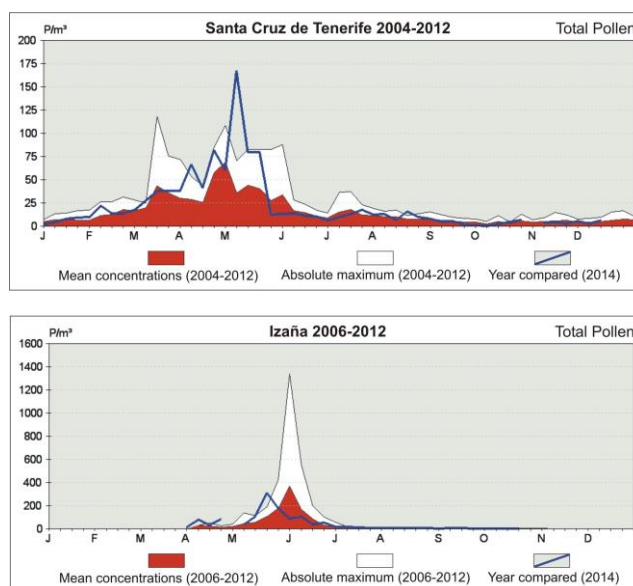

Figure 14.2. Dynamics of the mean weekly Total Pollen concentrations in Santa Cruz de Tenerife (upper) and Izaña (lower) during 2014 with regard to 2004-2012 mean data.

Table 14.1. Airborne pollen and spore spectrum for SCO, year 2014.

SANTA CRUZ DE TENERIFE
1 January 2014 - 31 December 2014

	YEAR		WEEK		DAY	
	Total Pollen	Percentage %	Maximum P/m ³	Week nr. Nr.	Maximum P/m ³	Date of the Maximum dd/mm/yyyy
TOTAL POLLEN	7290	100,0	167,5	18	411,6	02/05/2014
POLLEN FROM TREES	3151	43,2	83,4	18	221,2	02/05/2014
<i>Acacia</i>	0	0,0	0,0		0,0	
<i>Ailanthus</i>	5	0,1	0,2	26	1,4	27/06/2014, 16/08/2014
<i>Alnus</i>	2	0,0	0,1	7	0,7	11/02/2014, 15/04/2014
<i>Castanea</i>	29	0,4	2,8	28	16,8	11/07/2014
<i>Casuarina</i>	13	0,2	0,9	3	4,2	17/01/2014
CUPRESSACEAE	242	3,3	5,9	6	21,0	06/02/2014
<i>Eucalyptus</i>	16	0,2	0,7	48	2,1	03/05/2014, 25/08/2014
<i>Ilex</i>	2	0,0	0,1	13	0,7	24/03/2014, 16/05/2014
MORACEAE	288	3,9	8,3	33	48,3	17/08/2014
<i>Myrica</i>	1348	18,5	74,4	18	206,5	02/05/2014
OLEACEAE	246	3,4	13,7	20	61,6	18/05/2014
PALM TREES	528	7,2	7,8	29	18,2	20/07/2014, 18/08/2014
<i>Pinus</i>	228	3,1	9,9	15	32,2	01/04/2014
<i>Platanus</i>	4	0,1	0,3	12	1,4	22/03/2014
<i>Populus</i>	6	0,1	0,1	6	0,7	4/02/2014, 23/02/2014
<i>Quercus</i>	81	1,1	4,5	20	21,0	18/05/2014
<i>Salix</i>	2	0,0	0,1	11	0,7	15/03/2014, 11/04/2014
<i>Schinus</i>	105	1,4	3,4	29	18,2	18/07/2014
<i>Tilia</i>	0	0,0	0,0		0,0	-
<i>Ulmus</i>	1	0,0	0,1	11	0,7	12/03/2014
Other pollen from trees	8	0,1	-	-	-	-
POLLEN FROM SHRUBS	483	6,6	12,2	12	34,3	01/04/2014
CISTACEAE	1	0,0	0,1	42	0,7	13/10/2014
ERICACEAE	440	6,0	11,7	12	32,9	01/04/2014
<i>Ricinus</i>	35	0,5	0,5	12	3,5	02/05/2014
<i>Pistacia</i>	1	0,0	0,1	13	0,7	26/03/2014
Other pollen from shrubs	6	0,1	-	-	-	-
POLLEN FROM HERBS	3445	47,3	77,5	18	181,3	02/05/2014
COMPOSITAE total (incl. <i>Artemisia</i>)	1261	17,3	56,7	18	138,6	02/05/2014
<i>Artemisia</i>	1219	16,7	56,2	18	136,5	02/05/2014
BORAGINACEAE	11	0,2	0,5	11	2,8	02/05/2014
CYPERACEAE	7	0,1	0,3	43	1,4	04/01/2014
CRASSULACEAE	0	0,0	0,0		0,0	-
CRUCIFERAE	27	0,4	0,9	14	5,6	05/04/2014
<i>Euphorbia</i>	2	0,0	0,1	2	0,7	06/01/2014, 18/01/2014
GRAMINEAE (Grasses)	487	6,7	11,3	20	33,6	18/05/2014
<i>Mercurialis</i>	78	1,1	1,2	7	5,6	11/02/2014, 15/04/2014
<i>Plantago</i>	187	2,6	3,6	13	10,5	26/03/2014, 4/05/2014
<i>Rumex</i>	237	3,2	4,5	14	11,9	06/04/2014
CHENOPODIACEAE/AMARANTHACEAE	231	3,2	3,0	14	17,5	06/04/2014
URTICACEAE	802	11,0	11,0	11	23,1	08/03/2014
Other pollen from herbs	114	1,6	-	-	-	-

	YEAR		WEEK		DAY	
	Total Spores	Percentage %	Maximum S/m ³	Week nr. Nr.	Maximum S/m ³	Date of the Maximum dd/mm/yyyy
TOTAL SPORES	104294	100,0	874,8	20	1657,6	12/11/2014
<i>Alternaria</i>	960	0,9	24,8	20	44,8	12/05/2014
Ascospores	51526	49	611	96	1464	
<i>Aspergillus/Penicillium</i>	3693	3,5	43,6	43	190,4	07/01/2014
<i>Cladosporium</i>	30257	29,0	458,8	20	921,2	03/06/2014
<i>Ustilago</i>	6910	6,6	185,2	20	336	12/02/2014, 18/05/2014
Other fungal spores	10948	22,0	-	-	-	-

Table 14.2. Airborne pollen and spore spectrum for IZO, year 2014.

IZAÑA

24 March 2014 - 17 October 2014

	YEAR		WEEK		DAY	
	Total Pollen	Percentage %	Maximum P/m ³	Week nr. Nr.	Maximum P/m ³	Date of the Maximum dd/mm/yyyy
TOTAL POLLEN	8346	100	315,3	20	942,9	13/05/2014
POLLEN FROM TREES	2092	25,1	72,7	16	360,5	18/04/2014
<i>Acacia</i>	0	0,0	0,0		0,0	-
<i>Ailanthus</i>	0	0,0	0,0		0,0	-
<i>Alnus</i>	0	0,0	0,0		0,0	-
<i>Castanea</i>	34	0,4	1,3	23	8,4	05/06/2014
<i>Casuarina</i>	1	0,0	0,1	30	0,7	21/07/2014
CUPRESSACEAE	6	0,1	0,5	14	2,1	01/04/2014
<i>Eucalyptus</i>	1	0,0	0,1	14	0,7	01/04/2014
<i>Ilex</i>	0	0,0	0,0		0,0	-
MORACEAE	6	0,1	0,3	19	1,4	29/04/2014, 16/05/2014
<i>Myrica</i>	1038	12,4	59,4	19	283,5	15/05/2014
OLEACEAE	22	0,3	1,6	19	4,9	07/05/2014, 18/05/2014
PALM TREES	10	0,1	0,5	36	3,5	03/09/2014
<i>Pinus</i>	942	11,3	71,3	16	356,3	18/04/2014
<i>Platanus</i>	1	0,0	0,1	14	0,7	01/04/2014
<i>Populus</i>	4	0,0	0,5	14	3,5	01/04/2014
<i>Quercus</i>	23	0,3	1,2	19	3,5	07/05/2014
<i>Salix</i>	0	0,0	0,0		0,0	-
<i>Schinus</i>	1	0,0	0,1	14	0,7	06/04/2014, 15/05/2014
<i>Tilia</i>	0	0,0	0,0		0,0	-
<i>Ulmus</i>	0	0,0	0,0		0,0	-
Other pollen from trees	5	0,1	-	-	-	-
POLLEN FROM SHRUBS	259	3,1	30,1	14	186,9	01/04/2014
CISTACEAE	0	0,0	0,0		0,0	-
ERICACEAE	256	3,1	30,1	14	186,9	01/04/2014
<i>Ricinus</i>	2	0,0	0,2	20	1,4	18/05/2014
<i>Pistacia</i>	0	0,0	0,0		0,0	-
Other pollen from shrubs	1	0,0	-	-	-	-
POLLEN FROM HERBS	5522	66,2	245,6	20	924,7	13/05/2014
COMPOSITAE total (incl. <i>Artemisia</i>)	71	0,9	3,4	18	9,8	29/04/2014
<i>Artemisia</i>	69	0,8	3,4	18	9,8	29/04/2014
BORAGINACEAE	21	0,3	1,3	18	6,3	02/05/2014
CYPERACEAE	1	0,0	0,1	30	0,7	21/07/2014, 14/09/2014
CRASSULACEAE	0	0,0	0,0		0,0	-
CRUCIFERAE	4750	56,9	236,3	20	923,3	13/05/2014
<i>Euphorbia</i>	0	0,0	0,0		0,0	-
GRAMINEAE (Grasses)	95	1,1	2,4	25	5,6	21/06/2014
<i>Mercurialis</i>	12	0,1	1,0	14	4,2	31/03/2014
<i>Plantago</i>	17	0,2	0,5	14	2,1	18/05/2014
<i>Rumex</i>	123	1,5	3,8	14	11,2	06/04/2014
CHENOPODIACEAE/AMARANTHACEAE	36	0,4	1,9	14	7,0	31/03/2014
URTICACEAE	379	4,5	12,9	14	39,9	06/04/2014
Other pollen from herbs	18	0,3	-	-	-	-

	YEAR		WEEK		DAY	
	Total Spores	Percentage %	Maximum S/m ³	Week nr. Nr.	Maximum S/m ³	Date of the Maximum dd/mm/yyyy
TOTAL SPORES	22445	100,0	251,6	20	534,8	18/04/2014
<i>Alternaria</i>	291	1,3	3,2	18	11,2	07/05/2014, 12/05/2014
Ascospores	7112	31,7	79,2	14	193,2	04/04/2014
<i>Aspergillus/Penicillium</i>	448	2,0	17,6	15	95,2	21/08/2014
<i>Cladosporium</i>	11035	49,2	142,0	20	464,8	18/04/2014
<i>Ustilago</i>	1719	7,7	57,6	20	176,4	18/05/2014
Other fungal spores	1840	91,8	-	-	-	-

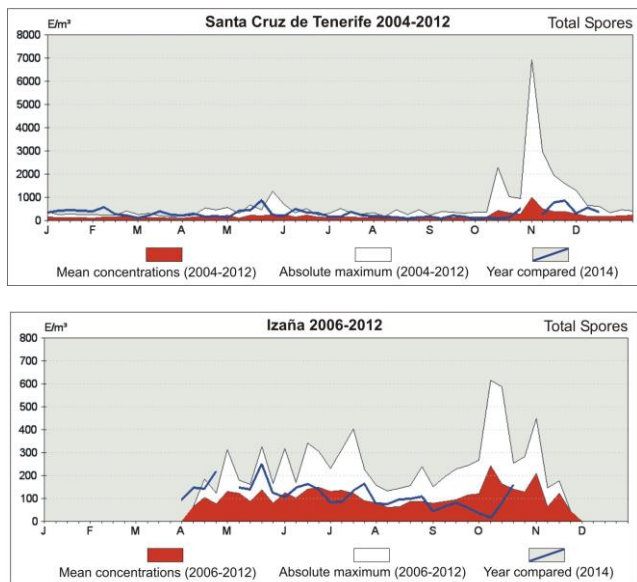

Figure 14.3. Dynamics of the mean weekly Total Fungal Spore concentrations in Santa Cruz de Tenerife (upper) and Izaña (lower) during 2014 with regard to 2004-2012 mean data.

Similar graphs for each particular taxa can be generated on the [webpage](#).

We can see how the annual course of total concentration of pollen and fungal spores at SCO is very different from that observed at IZO which, in turn, presents a great interannual variation depending on weather conditions such as temperature and precipitation. While in SCO concentration of pollen shows a broad maximum covering an extensive spring season (February to June), in IZO concentration of pollen concentrates in almost one month (late May to late June) with values that can be very high, much higher than those recorded for SCO (Fig. 14.2).

The total concentration of fungal spores shows a contrasting seasonal variation to that of total pollen. In SCO the highest concentrations occur between October and December, while significant values are observed at IZO from April to December, but an order of magnitude lower than those recorded in SCO (Fig. 14.3).

These results refer to total concentration of pollens and fungal spores. However individual pollens and fungal spores might have a quite different seasonal behaviour in each station (see Tables 14.1 and 14.2).

A number of products, such as current levels and forecasts of the main allergenic pollens and fungal spores, historical and current data and pollen calendar for SCO can be found at the Tenerife Aerobiology information (Proyecto EOLO-PAT) [web page](#).

14.4 Future Activities

- Continuation of pollens and fungal spores sampling, and aerobiological data analysis.
- Update of the airborne pollen and spores databases.
- Improvement of the information provided through the [webpage](#) and services to its users.
- Development of a smartphone application to inform weekly about pollen and spores prognostics.

14.5 References

Belmonte, J., Cuevas, E., Poza, P., González, R., Roure, J.M., Puigdemunt, R., Alonso-Pérez, S., Grau, F. *Aerobiología y alergias respiratorias de Tenerife*. Editor: Agencia Estatal de Meteorología/Ministerio de Medio Ambiente y Medio Rural y Marino, 2010. NIPO (versión electrónica): 784-10-006-2.

Belmonte, J., C. De Linares, A. Fernández-Llamazares, C. Díaz de la Guardia, P. Cariñanos, S. Alonso-Pérez, E. Cuevas, J.M. Maya, S. Fernández, I. Silva, R. Tormo, *Airborne Pinus pollen in Spain: pollination patterns and trends of the annual indexes and the peak dates*, 5th European Symposium on Aerobiology, Krakow, Poland, 3 - 7 September, 2012.

Belmonte, J., E. Cuevas: *Proyecto EOLO-PAT. Estudio de alérgenos en Canarias. Resumen anual de datos 2012*. Bellaterra: Proyecto EOLO-PAT, 2013.

14.6 Staff

Dr Jordina Belmonte (UAB; Head of programme)

Dr Emilio Cuevas (AEMET; Co-PI)

Sergio Afonso (AEMET; Sampling)

Rubén del Campo Hernández (AEMET; Sampling)

Virgilio Carreño (AEMET; Sampling)

Rut Puigdemunt (UAB; Technical Analyst)

David Navarro (UAB; Technical Analyst)

Concepción De Linares (UAB; Research Scientist)

Dr Silvia Alonso (CSIC/AEMET; Research Scientist)

Cándida Hernández (AEMET; Meteorological Observer-GAW Technician)

Concepción Bayo (AEMET; Meteorological Observer-GAW Technician)

Dr Fernando de Ory (AEMET; Meteorological Observer-GAW Technician)

15 Phenology

15.1 Main Scientific Goals

Phenology is the study of biological phenomena that occur periodically coupled to weather-related seasonal rhythms and to the annual course of the weather, in a particular place. These phenomena (migratory birds' phases, appearance of flowers or fruit ripening in plants, etc.) are sensitive to changes in weather and climate; hence, its detailed study may help better understand how these environmental variations affect living things. Therefore, WMO recommended to the National Meteorological Services to implement a phenological observations programme.

IZO is an excellent location for conducting phenological observations since it is located in a high mountain area on an island with a large number of endemic species. The endemic species are adapted to specific environmental conditions, which make them particularly sensitive to small environmental changes, and therefore their study is of great interest.

AEMET has operated a programme of phenological observations since the 1940s, but its focus has been largely on agricultural applications. However, in 2014 IZO joined AEMET's network of phenological stations in order to better understand the relationship between the life cycles of endemic wildlife of the environment and the specific and unique climate of the area. The programme started in collaboration with the Teide National Park authority.

The programme of phenological observations at IZO was established with the commitment to maintain long-term and permanent observations; we can only obtain valuable information if observations are performed systematically for many years. The clearest examples are the weather observations.

15.2 Measurement Programme

Currently we are studying the taxa shown in (Fig. 15.1), all of them endemic, corresponding to the higher elevations of the island of Tenerife. We study, for each taxon, the emergence of the inflorescence, or the appearance of flower buds, flowering, and fruit development according to the BBCH code (Biologische Bundesanstalt, Bundessortenamt und Chemische Industrie) adopted by AEMET. The phenological stages that are taken into account are detailed in Table 15.1.

We also employ another encoding (Table 15.2), used by the technicians of the Teide National Park and based on the model proposed by Anderson and Hubricht (1940) within the joint phenological project with this institution. In this methodology, three biological phases (inflorescence emergence or development of flower buds; flowering and

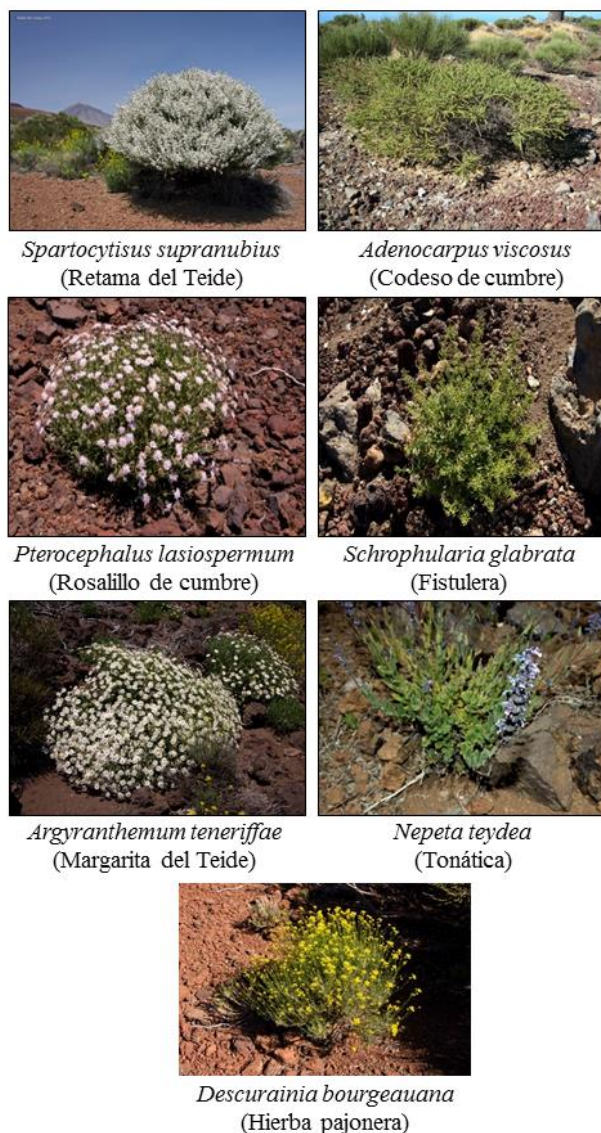

Figure 15.1. Endemic taxa typical from high lands of the island of Tenerife, which are analysed in the Phenology programme.

fruit development) and their percentage in the population development of each taxa are considered. Phenological observations are visual, so we chose nine sampling points around IZO where there is a good representation of healthy adult specimens of the studied taxa. For each observation point we estimate the percentage of phenological phases, translating this percentage to the aforementioned codes. The selected sampling points are marked in Fig. 15.2.

The phenological observations are made on a weekly basis at the time of the appearance of buds, flowering and fruit growth and every fortnight in pre- and post-development weeks of these stages, and on a monthly basis during the winter months.

Table 15.1. Phenological stages: BBCH code.

BBCH code	Description
55	Emergence of the corolla, visible petals closed, "tip petals"
60	First flowers open
61	10% of flowers open (beginning of flowering).
63	Flowering to 30%
65	Bloom 50% (full bloom)
79	End of fruit formation (practically reach their final size)

Table 15.2. Phenological stages: Anderson & Hubricht code.

Code	Description (valid for each stage: inflorescence, flowering and fruit)
A	Absent
B	From the first specimens up to 10%
C1	from 10 to 30% of buds / flowers / fruits
C2	Between 30 and 50%
D	More than 50%
E1	Between 50 and 30%
E2	Between 30 and 10%
F	Less than 10% of specimens



Figure 15.2. Aerial view of the surroundings of the Izaña Atmospheric Observatory indicating the selected sampling points, those on the north-west slope are marked in blue and those on the south-east slope are marked in yellow.

15.3 Summary of remarkable results during the period 2012-2014

Since the phenological observations programme began in 2014, there is only one full season of study, and it is too early to relate the results obtained to climate characteristics. However, this first season has been very important for developing and implementing the methodology. In addition, we have documented some new aspects that until now had not been systematically observed, such as the duration of the flowering stage in different taxa, as shown in Fig. 15.3.

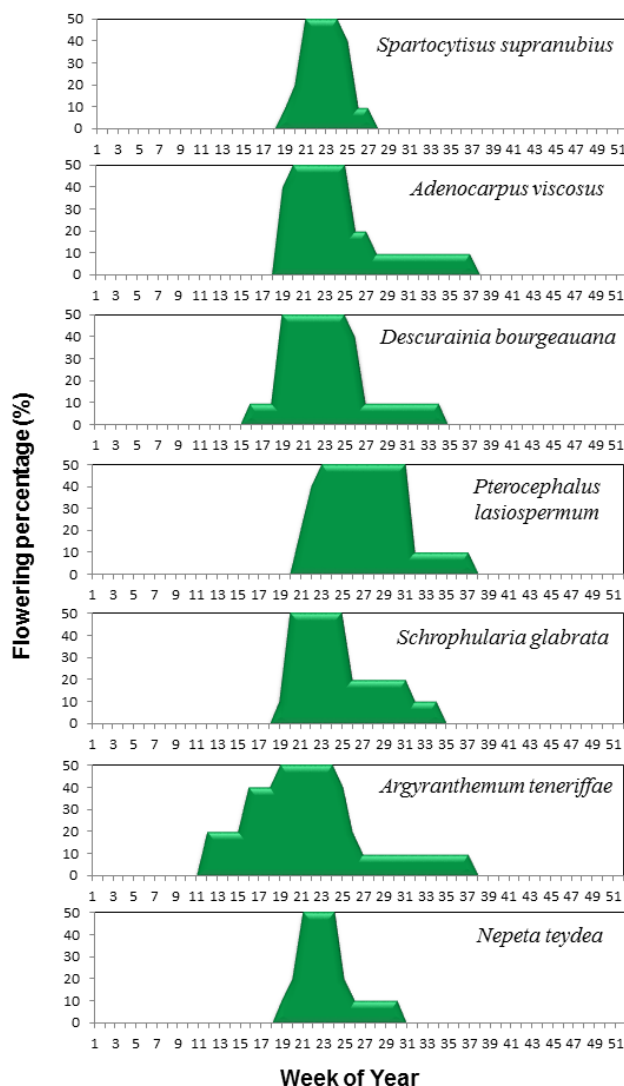

Figure 15.3. Duration of the flowering stage in different taxa at Izaña, 2014.

15.4 Development of a gauge for measuring the water from fog

In the summits of Tenerife the annual precipitation is around 430 mm, but there is a large inter-annual variation. Fog is thought to provide a significant additional contribution of water to vegetation in drought years, as the vegetation is able to capture some of the water contained in the fog droplets. In order to have data on the amount of water that can be obtained from the fog, a rain gauge was adapted following the guidelines of the WMO technical note (2008) and installed in 2009. The gauge comprises a metal mesh above a cylinder of 10 cm diameter and 22 cm height, and a frame of 0.2 cm x 0.2 cm, which mimics the capture of fog droplets by the plants, although we assume this is quite difficult to achieve because much depends on the leaf morphology, orientation of the plant, wind, etc. The adapted rain-gauge and a close-up of the wire mesh installed are shown in Fig. 15.4.

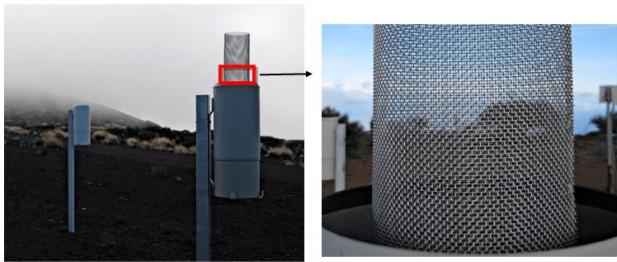

Figure 15.4. Adapted rain-gauge and a close-up of the wire mesh.

The results obtained so far indicate that the water supply due to fog is substantial. In the 2013-2014 hydrometeorological year the adapted gauge collected nearly five times more water than the conventional one. This proportion was much higher (14 times more water from fog than from rain) during the extremely dry 2011-2012 hydrometeorological year (Fig. 15.5).

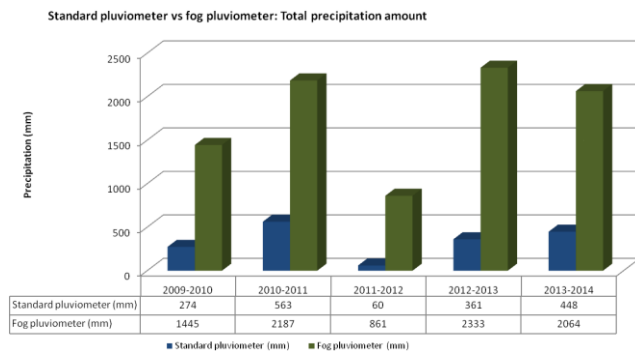

Figure 15.5. Comparison of the precipitation collected with standard rain gauge and the modified fog-rain gauge for the last five hydrometeorological years.

15.5 References

Anderson, E and Hubricht, L, A method for describing and comparing blooming seasons, Bulletin of the Torrey Botanical Club, 639-648, 1940.

WMO, Guide to Meteorological Instruments and Methods of Observation, WMO, N° 8, Seventh edition, 2008.(accessible at http://www.wmo.int/pages/prog/gcos/documents/gruanmanuals/CIMO/CIMO_Guide-7th_Edition-2008.pdf)

15.6 Staff

Rubén del Campo Hernández (AEMET; Head of programme)

Candida Hernández Hernández (AEMET; Meteorological Observer-GAW Technician)

Ramón Ramos (AEMET; Head of Infrastructure)

International Cooperation Programmes

16 AERONET-Europe Calibration Service

The AERosol RObotic NETwork (**AERONET**) is a ground-based standardized automatic sun/sky-photometer network devoted to the characterization and monitoring of aerosol properties. AERONET sites are located worldwide, with also a high number in Europe. AERONET is practically the only facility available worldwide to satellite and atmospheric modelling communities to verify and validate both near real time and long-term aerosol products. It is widely used in the Global Monitoring for Environment and Security (GMES) Monitoring Atmospheric Composition and Climate project (**MACC-II**), the Climate Change Initiative (CCI) and the WMO Sand and Dust Storm Warning Advisory and Assessment System (**SDS-WAS**) for Northern Africa, Middle East and Europe.

The AERONET-EUROPE Calibration Service, financed by the Aerosol Cloud and TRace gas InfraStructure (ACTRIS) European Research Infrastructure Action (FP7/2007-2013) offers to the whole scientific community a unique sun-photometer facility for calibration and maintenance, operating within the AERONET federation (Goloub et al., 2012; 2013; 2014). This Trans National Access (TNA) handles a calibration service for instruments operated at current and future AERONET sites, thus, complementing the NASA calibration center based in Washington-USA. AERONET-Europe Calibration Service is a multi-site infrastructure (Fig. 16.1) with facilities at Lille (LOA, France) and Valladolid (GOA, Spain), devoted to inter-calibration of field instruments, and at IZO, a unique facility for absolute calibration of Master Cimel instruments.

IZO hosts a set of eight reference instruments continuously in operation and available for the needs of the LOA and GOA facilities. The Master instruments are recalibrated every 3 months in order to assure measurement accuracy (Fig. 16.2).

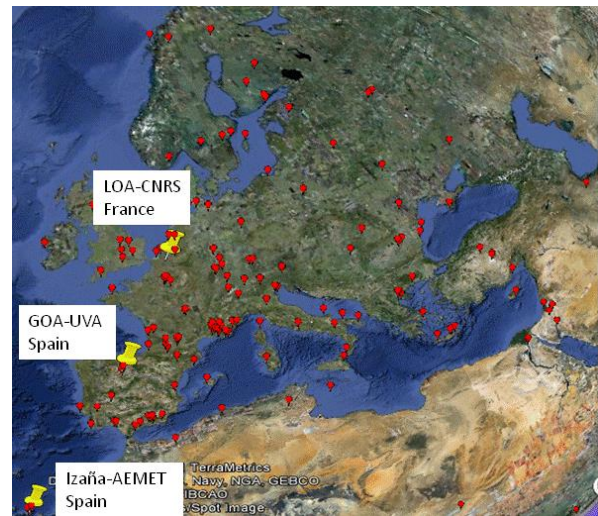

Figure 16.1. Location of the three calibration facilities of AERONET-Europe.

All users operating for their research activity either a standard or a polarized CIMEL sun/sky photometer located in Europe or run out of Europe in the framework of international cooperation agreements can submit a proposal to AERONET-Europe Calibration Service at any time. The instrument calibration and maintenance is performed free of charge, and proposals are granted on the basis of a TNA selection panel review process. Instrument shipping expenses from and to the user site are not included and must be covered by the user institution.

Most of the accesses provided under AERONET-Europe allow to assure quality of data on sites operating not only a sun-photometer but also multiple complementary in situ and remote sensing instruments. This aspect provides a clear integration of sun-photometers, LIDARs and in situ aerosol instruments. The number of accesses provided by AERONET-Europe was 138, from 1st October 2012 to end of March 2014, specifically 66, 37 and 35 for LOA, GOA and IZO, respectively.

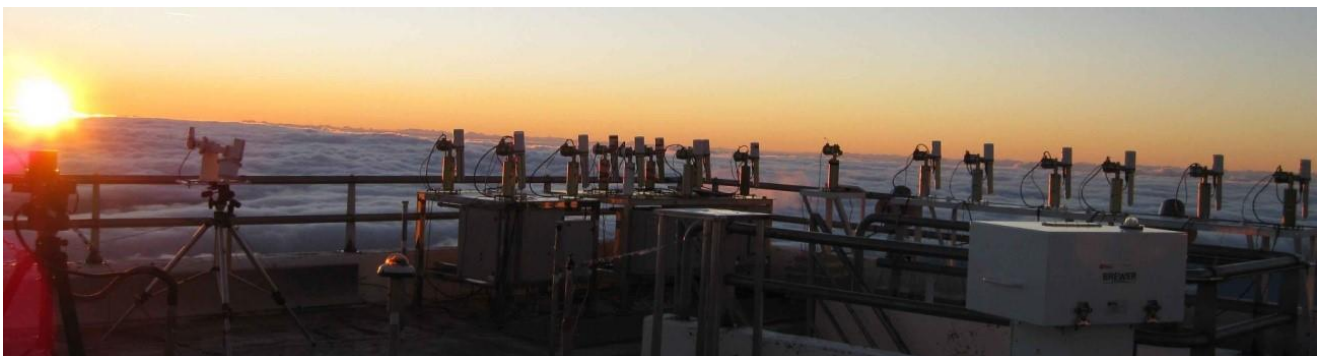

Figure 16.2. Cimel Masters at the Izaña Atmospheric Observatory AERONET-Europe Calibration facility.

In addition to the calibration activity provided by AERONET-Europe to European users for European sites, several accepted proposals involved European users deploying their instruments during either field experiments or in a more permanent manner out of Europe, for example, in Northern Africa, South East-Africa, Central Asia, Asia and Antarctica. These calibrations also provided a good opportunity for linking the AERONET network to other sun-photometer networks operating or starting operation in the world. Several proposals involved other existing technologies and new technologies under evaluation.

Data quality, instrument performance and well-trained site managers are, after calibration, the keys of success to be considered by AERONET-Europe. Thanks to these activities, several sites/instruments previously managed/calibrated by NASA and insufficiently managed by the users, have been renovated.

Quality-assured data from AERONET-Europe are widely used by modelling and satellite communities through several European programs and initiatives (ESA, MACC-II, GMES, AEROCOM, etc). By the end of 2012, around 40 AERONET sun-photometers were used for near real time validation by the SDS-WAS Regional Center for North Africa, Middle East and Europe, most of them calibrated by AERONET-Europe. MACC-II (Monitoring Atmospheric Composition and Climate, GMES Atmosphere Service) also performs near real time use of AERONET data for specific model aerosol products verification.

16.1 Future activities

AERONET-Europe will be reinforced and expanded within ACTRIS-2 by providing a fast and efficient calibration and standard maintenance service for sun/sky/polar/lunar photometers, and through the instrument status monitoring with Quality Check during operation in the field, and Quality Assurance.

16.2 References

- Goloub, P., V. E. Cachorro, E. Cuevas, L. Blarel, A. Berjon, C. Toledano, A. Lapionak, C. Guirado, R. Ramos, R. González, D. Fuentes, The AERONET-Europe calibration facility: access within the ACTRIS Project, 2012 European Aerosol Conference (EAC-2012), B-SS01S1P12, Granada-Spain, 2- 7 September, 2012.
- Goloub, P., V. Cachorro and E. Cuevas, Service for Calibration / Maintenance Facilities dedicated to Aerosols monitoring, ACTRIS Project ACTRIS MTR Meeting - Brussels, Belgium, 6-7 June, 2013.
- Goloub, P., V. Cachorro, and E. Cuevas, WP 18/TNA12 : AERONET-EUROPE Calibration Center, 4th ACTRIS General Assembly Meeting, Clermont Ferrand, France, June 12th, 2014.

16.3 Staff

Dr Emilio Cuevas (PI of Izaña-AEMET facility)

Carmen Guirado Fuentes (UVA/AEMET; Research Scientist)

Dr Philippe Goloub (PI of LOA-CNRS/University of Lille facility)

Dr Carlos Toledano (PI of GOA-University of Valladolid facility)



17 Regional Brewer Calibration Center for Europe (RBCC-E)

17.1 Background

In November 2003 the WMO/GAW Regional Brewer Calibration Center for Europe (RA-VI region) (RBCC-E) was established at IZO. The RBCC-E reference is based on three double Mark-III Brewer spectrophotometers (the IZO triad): a Regional Primary Reference (Brewer 157), a Regional Secondary Reference (Brewer 183) and a Regional Travelling Reference (Brewer 185) (Fig. 17.1). As described in Section 3.1, IZO is located in a subtropical region (28°N) on a mountain plateau (2373 m a.s.l.) with pristine skies and low ozone variability. This location allows routine absolute calibrations of the references in similar conditions to the Mauna Loa Observatory (MLO), Hawaii, USA. The establishment of the RBCC-E Triad allows the implementation of a self-sufficient European Brewer calibration system that respects the world scale but works as an independent GAW infrastructure.

There are two European Calibration Centers for the two types of ozone spectrophotometers in use: Dobson and Brewer. The Regional Dobson Calibration Center for Europe (RDCC-E) is located at the Meteorological Observatory Hohenpeissenberg (Germany). Since 2009, the RBCC-E activities have largely been funded by the ESA project, “CEOS Intercalibration of Ground-Based Spectrometers and Lidars” which includes the participation of the two European Calibration Centers (RBCC-E and RDCC-E).

17.2 Objectives

The main objectives of this Cooperation programme are:

- To implement a system for routine absolute calibrations of the European Brewer regional reference instruments at IZO, fully compatible with absolute calibrations of the world reference triad at MLO.
- To perform periodical calibration campaigns using the Regional Primary Reference B157 (during intercomparisons held at IZO) and the Regional Travelling Reference B185 spectrophotometer (traceable to B157) in continental campaigns.
- To perform regular comparisons of the Regional Brewer Primary Reference B157 with the Regional Dobson Reference D074 to monitor the relationship between both calibration scales in the RA-VI region.
- To study the sources of errors of the absolute calibrations and to determine the accuracy of total ozone measurement achievable by this method under different atmospheric conditions or instrumental characteristics.



Figure 17.1. RBCC-E Brewer spectrophotometer triad located at Izaña Atmospheric Observatory (Photo: Alberto Redondas).

17.3 Tasks

The main tasks of this Cooperation programme are:

- To develop quality control procedures and Standard operating Procedures (SOPs) for traceability of measurements to the reference standards.
- To maintain laboratory and transfer standards that are traceable to the reference standards.
- To perform regular calibrations and audits at GAW sites.
- To provide, in cooperation with Quality Assurance/Science Activity Centres, training and technical assistance for stations.

17.4 GAW Scientific Advisory Group for Ozone

The GAW Scientific Advisory Group for Ozone (GAW SAG Ozone) monitors the activities in the stratospheric ozone programme, overlooks and gives guidance to the World Ozone and UV Data Centre and the Calibration Centres, and establishes and helps publish standard operating procedures. In addition, it helps with capacity building activities, makes recommendations about measurement techniques, calibration schedules and relocation of redundant instruments, and provides recommendations for all participants of the Ozone Network. The group consists of 19 international experts. Alkiviadis Bais (Greece) has been the chair of the GAW SAG Ozone since 2013. Alberto Redondas (IARC) as site manager of the RBCC-E has been a member of the GAW SAG Ozone since 2005.

17.5 Main activities of the RBCC-E during the period 2012-2014

17.5.1 Absolute calibration transfer

The RBCC-E Brewer triad transfers the calibration from the world reference triad, located in Toronto (Canada) and managed by Environmental Canada, Meteorological Service of Canada (EC-MS). The RBCC-E travelling reference Brewer#185 ensures the world reference transference to the WMO-Region VI Brewer network. The link of the RBCC-E triad to the world reference has been performed in the past using the travelling standard Brewer#017 managed by the International Ozone Service (IOS) (Figs 17.2 and 17.3). The WMO GAW SAG ozone in 2011 authorized RBCC-E to conduct the transference of its

own absolute calibration, based on Langley analysis at IZO. The link to the world reference will be by direct intercomparison with the world triad in Toronto or by common Langley campaigns at MLO or at IZO (Redondas 2014a).

The Absolute calibration of Reference Dobson and Brewer was performed and assessed during the Izaña September-October 2012 campaign and regular comparison with the standard Dobson has been performed during regular calibrations campaigns (see Table 17.1). The comparison with the standard Dobson with its current calibration level (traced back to the World Primary Standard D083) measures about 1% lower ozone than the standard Brewer with somewhat larger but explainable differences at low sun, high ozone and high turbidity (Khöler et al., 2012).

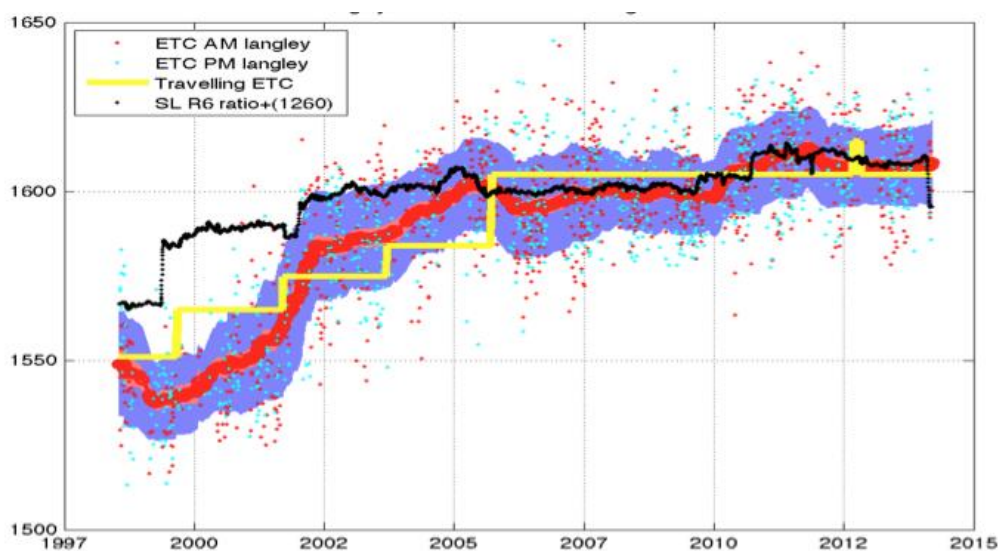

Figure 17.2. Long-term comparison (1998-2014) of the Extraterrestrial constant (ETC) transferred during regular comparisons with the travelling standard Brewer #017 (yellow line) and the ETC obtained by Langley-plots at IZO for the RBCC-E primary reference Brewer #157. The red line is the monthly smoothed ETC obtained by the Langley. The red area represents the 95% confidence interval of the mean and the blue area represents one standard deviation.

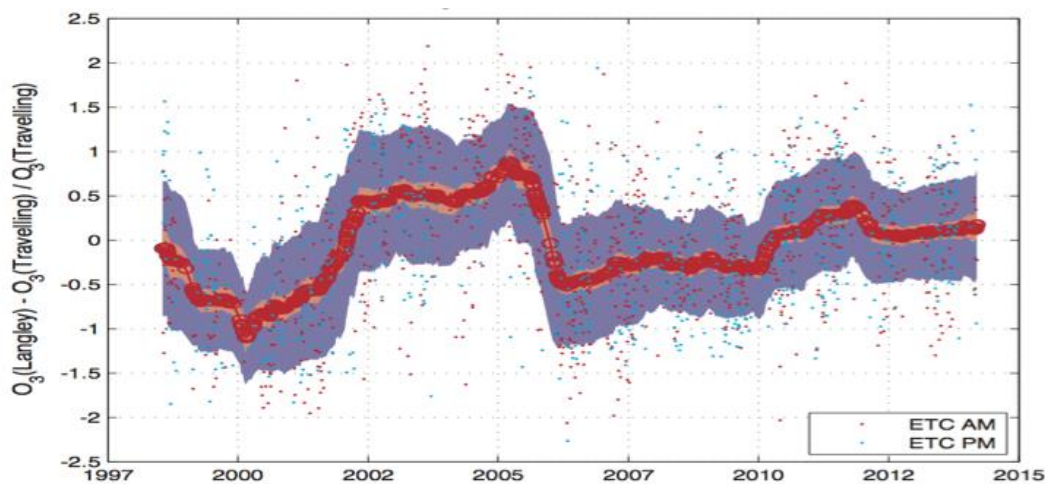

Figure 17.3. Effect on the Ozone measurement if we use the Langley calibration (Fig. 17.2) versus the calibration from travelling reference Brewer #017 on the RBCC-E primary reference Brewer #157 (assuming an ozone total content of 300 DU and airmass 2). The red line is the monthly smoothed percentage difference. The red area represents the 95% confidence interval of the mean and the blue area represents one standard deviation.

A key outcome of this campaign is that IZO was found to be adequate for absolute calibrations of both types of spectrophotometers using the Langley Plot method. The resulting calibrations are comparable to those commonly performed at Mauna Loa using the World Primary Standard (Khöler et al., 2012; Redondas et al., 2013). There is no significant change on the calibration if we use the Dobson methodology on the Brewer. The deviation in Langley extrapolation on both instruments are related, which confirms the deviation is due to the atmospheric variability and not to instrument performance.

17.5.2 RBCC-E Intercomparison campaigns

Brewer intercomparisons are held annually, alternating between Arosa in Switzerland and the El Arenosillo Sounding Station of the INTA at Huelva in the south of Spain. The aim is for a number of Brewers from invited organizations to collect simultaneous ozone data so that their calibration constants can be transferred from the reference instruments. Three regular intercomparison campaigns were organized by the RBCC-E during this reporting period (2012-2014), the Seventh and Ninth RBCC-E intercomparison campaign held at Arosa

(Switzerland, 16-27 July 2012 and 14-24 July 2014) and the Eighth RBCC-E intercomparison campaign held at El Arenosillo (Spain, 10-21 June 2013) (Table 17.1) (Redondas et al., 2014b). The geographical origin of the Brewers calibrated by the RBCC-E is shown in Fig. 17.4 and the number of calibrations performed by the RBCC-E every year is shown in Fig. 17.5. On average, 17 calibrations are performed every year.

These routine intercomparison campaigns provide the Brewer community with the opportunity to assess the European network instruments status. The initial comparison, using the instruments' original calibration constants, shows that all of the operative instruments are in the +/-2% range, 80% are within 1% range and 2/3 show a perfect agreement of +/- 0.5% after two years calibration period. After the maintenance and calibration carried out during the campaigns, the agreement was very good for all the instruments (within the 0.5% range for the stray light free region). The travelling reference stability is checked before and after every campaign, with the triad. These instruments are continuously monitored and demonstrate a long term precision of 0.25% between them.

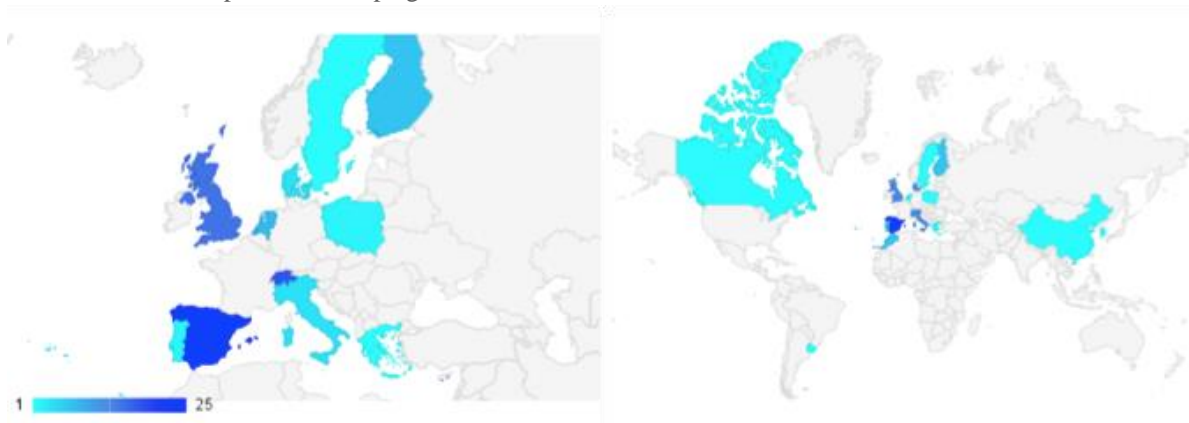

Figure 17.4. Geographical origin of the Brewers calibrated by the RBCC-E.

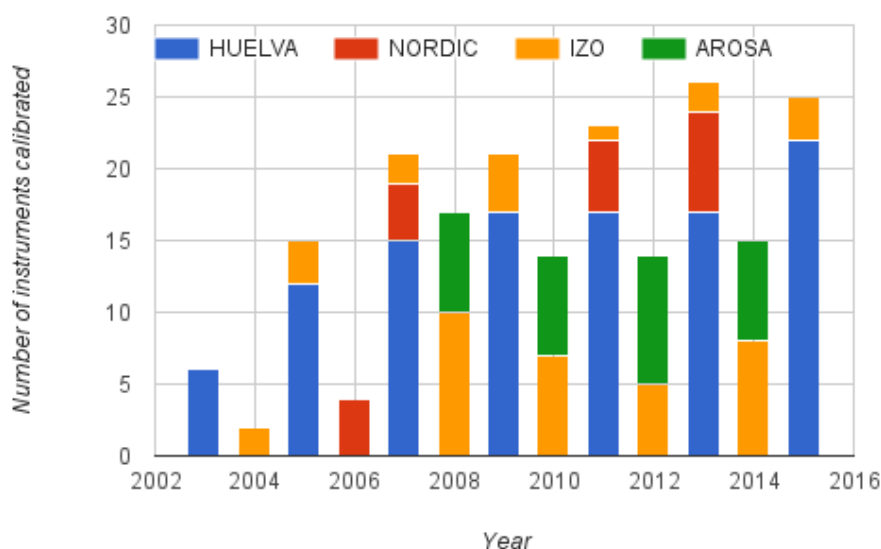

Figure 17.5. Calibrations performed by the RBCC-E per year.

Table 17.1. Campaigns performed during the period 2012–2014 organized by the RBCC-E.

Institution	Participants	Instrument	Country
Arosa 2012 (Switzerland, 16-27 July 2012) RBCC-E/RDCC-E			
International Ozone Services (IOS)	Martin Stanek Volodya Savastiouk	Brewer #017-MKII	Canada
Arosa Lichtklimatisches Observatorium (LKO)	René Stübi Herbert Schill Werner Siegrist	Brewer #040-MKII Brewer #072-MKII Brewer #156-MKIII	Switzerland
AAB	Henri Diemoz	Brewer #066-MKII	Italy
University of Rome (URO)	Giuseppe R. Casale	Brewer #067-MKII	Italy
Kipp & Zonen (K&Z)	Wim Roeterdink	Brewer #158-MKIII	The Netherlands
World Radiation Center (WRC)	Julian Gröbner Gregor Huelsen	Brewer #163-MKIII	Switzerland
IARC-AEMET	Alberto Redondas Juan J. Rodríguez Virgilio Carreño Marta Sierra	Brewer #185-MKIII	Spain
Izaña 2012 (Spain, 24 September-12 October) RBCC-E/RDCC-E			
IARC-AEMET	Alberto Redondas Juan J. Rodríguez Virgilio Carreño Marta Sierra	Brewer #185-MKIII Brewer #183-MkIII Brewer #157-MkIII	Spain
Meteorological Observatory of Hohenpeissenberg (MOHp)	Ulf Koehler Herbert Munier	Dobson #064	Germany
Arenosillo 2013 (Spain, 10-21 June) RBCC-E			
IARC-AEMET	Alberto Redondas Juan J. Rodríguez Virgilio Carreño	Brewer #183-MKIII Brewer #185-MKIII	Spain
International Ozone Services (IOS)	Ken Lamb Martin Stanek Volodya Savastiouk	Brewer #017-MKII	Canada
Kipp & Zonen (K&Z)	David Godoy Keith M. Wilson	Brewer #158-MKIII	The Netherlands
Instituto Nacional de Técnica Aeroespacial (INTA)	Jose Manuel Vilaplana	Brewer #150-MKIII	Spain
IARC-AEMET	J.R. Moreta González Daniel Moreno J.M San Atanasio Angel Miguel Boned Francisco Escribá Francisco García	Brewer #070-MKIV Brewer #186-MKIII Brewer #166-MKIV Brewer #117-MKIV Brewer #151-MKIV	Spain
Algerian Meteorology Service (WMO)	Ouchene Bouziane Mohammed Salah Ferroudj	Brewer #201-MKIII	Algeria
UK Meteorological Office (UKMO)	John Rimmer Peter Kelly	Brewer #075-MKIV Brewer #126-MKII Brewer #172-MKIII	U.K.
Direction de la Météorologie Nationale (DMN)	Hamza Rachidi Mohammed Jamaledine Abdelkarim Faquih	Brewer #051-MKII Brewer #165 - MKIII	Morocco
World Radiation Center (WRC)	Luca Egli Christian Thomann	Brewer #163-MKIII QUASUME	Switzerland

Institution	Participants	Instrument	Country
Izaña 2013 (Spain, 30 October–19 November 2013) FMI/RBCC-E (Nordic)			
RBCC-E AEMET	Alberto Redondas Juan J. Rodríguez Virgilio Carreño Marta Sierra	Brewer #157-MKIII Brewer #183-MKIII Brewer #185-MKIII	Spain
Finnish Meteorological Institute (FMI)	Pauli Heikkinen Tomi Karppinen Juha M. Karhu	Brewer #037-MKII Brewer #214-MkIII	Finland
Danish Meteorological Institute (DMI)	Paul Eriksen Nis Jepsen	Brewer #053-MKII Brewer #082-MKII Brewer #202-MKIII	Denmark
Izaña 2014 (Spain, 1 April-20 May) RBCC-E			
Environmental Canada (EC)	Volodya Savastiouk	Brewer #145-MkIII	Canada
IARC-AEMET	Alberto Redondas Juan J. Rodríguez Virgilio Carreño Marta Sierra	Brewer #157-MKIII Brewer #183-MKIII Brewer #185-MKIII	Spain
Arosa 2014 (Switzerland, 14-24 July 2014) RBCC-E			
International Ozone Services (IOS)	Martin Stanek Volodya Savastiouk	Brewer #017-MKII	Canada
Arosa Lichtklimatisches Observatorium (LKO)	René Stübi Herbert Schill Werner Siegrist	Brewer #040-MKII Brewer #072-MKII Brewer #156-MKIII	Switzerland
Kipp & Zonen (K&Z)	Alexander Visser Pavel Babal	Brewer #158-MKIII Brewer #212-MKIII	The Netherlands
IARC-AEMET	Alberto Redondas Juan J. Rodríguez Virgilio Carreño	Brewer #185-MKIII	Spain

17.5.3 Nordic Campaigns

Several campaigns were organized at Sodankylä, Finland (2011) and the corresponding counterparts at IZO (2009, 2011, 2013) with the main objective to study the stray-light effect in single Brewers. During these campaigns the Finnish Meteorological Institute (FMI) Brewer (operational since 1988) was operated for 4-6 weeks in parallel to the European Brewer at IZO (during the Northern Polar Winter) and at Sodankylä during early spring.

The stray-light effect was characterized during the campaigns and this was used to develop a deterministic model suitable for corrections (FMI model) (Karppinen et al., 2014). In parallel, a stray-light empirical model developed during the Sodankylä Total Column Ozone Intercomparison (SAUNA) campaigns was adapted and included in the calibration procedure of RBCC-E (Fig. 17.6). The comparison of both methods agrees quite well (Fig. 17.7). The application of the method to the Brewer #037 suggests that the non-linear parameters accounting for the stray light do not depend on the change in time of the instrument response. This supports the strategies of the model developed by FMI based on the stray light characterization of the instrument.

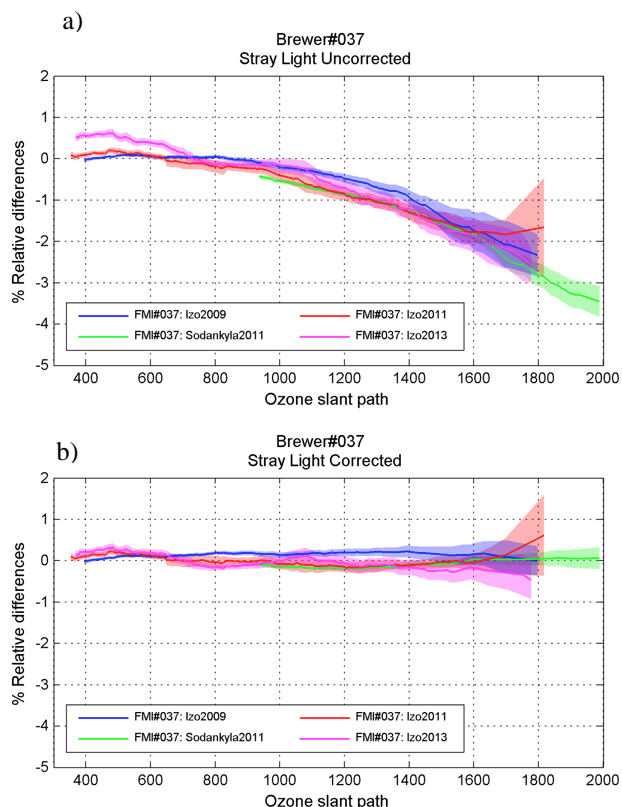

Figure 17.6. Ozone relative differences (%) of Brewer #037 to RBCC-E standard instruments Brewer #183 and Brewer #185 a) without and b) with stray light correction, during several intercomparison campaigns (Izaña 2009, Sodankylä 2011, Izaña 2011 and Izaña 2013). Shaded areas represent the 95% confidence interval in the mean.

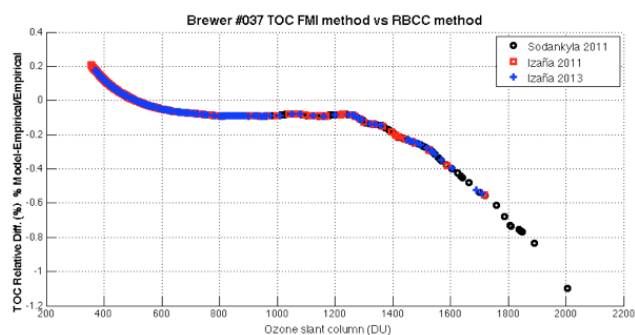

Figure 17.7. Total ozone column (TOC) relative difference (%) between the FMI stray light model and the empirical correction, from the comparison of a double Brewer during 2011 and 2013 campaigns.

The FMI stray light model slightly overestimates the ozone at low ozone slant column (OSC) whereas it underestimates the correction at high OSC. For standard conditions (300-1400 DU) the agreement between two methods is very good.

17.5.4 Technical developments

RBCC-E activities related to technological aspects include: 1) the development of the calibration laboratory (Guirado et al., 2012; Mendez-Ramos et al., 2014); 2) the evaluation of an instrumental model using radiative transfer codes (Carreño et al., 2014; Karppinen et al., 2014); 3) the improvement of the characterization and calibration of the Brewer instrument (Redondas and Rodríguez, 2012; Redondas et al., 2014b; Rodríguez-Franco et al., 2014) and 4) the development and update of Brewer measurement techniques (Diemoz et al., 2014).

17.5.5 Training activities

There have been various training activities during the 2012-2014 period.

Brewer Training for the Antarctic Institute of Uruguay. Izaña, June-July 2012

There was a continuation of the collaboration with the Uruguay Antarctic Institute through the calibration of Brewer #155 and training of Brewer operator (Izaña, 2012).

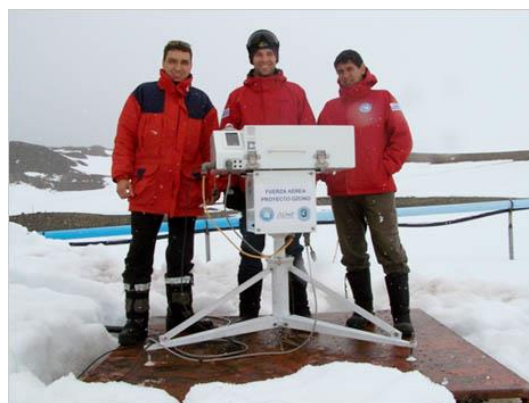

Figure 17.8. Installation of Brewer #155 (Uruguay Antarctic Institute) at Base Artigas, Antarctica (Lat: -62.15 Lon: 58.87).

Brewer Training course: Izaña, December 2012

A Brewer operation and data analysis training course for experts from the Korean Meteorological office was held at the Izaña Atmospheric Observatory, Tenerife during December 2012 (Fig. 17.9).

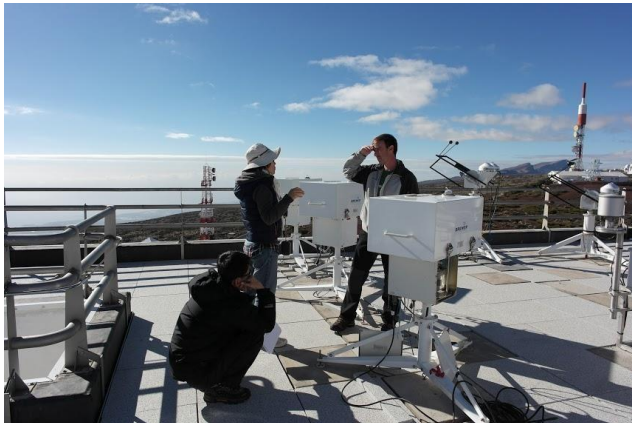

Figure 17.9. Brewer training course for the Korean Meteorological office at IZO, December 2012.

GAW Sahara Brewer Training course: El Arenosillo, 10-21 June 2013

The GAW Sahara Brewer Training course funded by AECID and organized by the University of Extremadura, was held during the VIII RBCC-E campaign, 10-21 June 2013, El Arenosillo, Spain (Fig. 17.10).



Figure 17.10. GAW Brewer training course, El Arenosillo, Spain, 10-21 June 2013. David Godoy (Kipp & Zonnen) Brewer training course instructor at Huelva shows the principles of the instrument in a practical lecture. From left to right Ferroudj Mohammed Salah (Algeria), Mohammed Jamaledine (Morocco), David Godoy, Admed Gahein (Egypt), Ouchene Bouziane (Algeria), Hamza Rachidi (Morocco) and Jung Mi Lee (Korea).

EUBREWNET training school and Brewer Ozone Spectrophotometer open congress in conjunction with the 14th Biennial WMO-GAW Brewer Users Group Meeting: Tenerife, 24-28 March 2014

The event was a collaboration of EUBREWNET (COST Action ES1207) and WMO-GAW. The event was hosted by AEMET in Tenerife, 24-28 March 2014, in collaboration with the Spanish Oceanographic Institute. The training school and congress were focused on operational, scientific and technical issues of the Brewer instrument. Topics included:

- Scientific presentations and technical issues of the Brewer.
- Instrument and data quality.
- The global Ozone monitoring network.
- Data processing advances and website developments.
- Exchange of information by those involved in the use of Brewers for UV and Ozone monitoring.
- Workshops covering practical setup of the Brewer, maintenance, and processing software use.

The presentations are available [here](#) (as links on the programme).



Figure 17.11. Participants of the 14th Biennial WMO-GAW Brewer Users Group Meeting, during the visit to Izaña Atmospheric Observatory, March 2014.

Brewer Training course: Izaña, 2–7 June 2014

A Brewer operation and data analysis training course was held at Izaña Atmospheric Observatory, Tenerife during 2–7 June 2014.

17.6 References

- Carreño, V., Redondas, A. and Diemoz, H., "Brewer Model", COST 1207 European Brewer Network. Netherlands, Delft, 11th, November, 2014.
- Diémoz, H., Siani, A. M., Redondas, A., Savastiouk, V., McElroy, C. T., Navarro-Comas, M., and Hase, F.: Improved retrieval of nitrogen dioxide (NO₂) column densities by means of MKIV Brewer spectrophotometers, *Atmos. Meas. Tech.*, 7, 4009-4022, doi:10.5194/amt-7-4009-2014, 2014.
- Guirado, C., R. Ramos, A. de Frutos, A. Berjón, A. Redondas, C López, V. Cachorro, E. Cuevas, R. González, S. González, M. Hernández, Optical calibration facility at the Izaña Atmospheric Research Center, *Opt. Pura Apl.*, 45 (1) 57-62, Special Section: 37th AMASOM Instrumentation and Techniques, 2012.
- Karppinen, T, A. Redondas, R.D. García, K. Lakkala, C.T. McElroy & E. Kyrö, Compensating for the Effects of Stray Light in Single-Monochromator Brewer Spectrophotometer Ozone Retrieval, *Atmosphere-Ocean*, DOI: 10.1080/07055900.2013.871499, 2014.
- Khöler, U., A. Redondas, E. Kyrö, Regional Calibration Centers for Dobson and Brewer in Europe - A joint venture for highest quality in monitoring the ozone layer, *Quadrennial Ozone Symposium 2012 (QOS 2012)*, ID:5967, Toronto, Canada, August 27th-31th, 2012.
- Méndez-Ramos, J., P. Acosta-Mora, J.C. Ruiz-Morales, M. Sierra, A. Redondas, E. Ruggiero, L. Salassa, M.E. Borges and P. Esparza; Rare-earth doped colour tuneable up-conversion ZBLAN phosphor for enhancing photocatalysis, *Optical Materials*, November 2014.
- Redondas, A. and Rodríguez, J.J. Regional Brewer Calibration Center - Europe CEOS campaigns: instrumental findings, *Quadrennial Ozone Symposium 2012 (QOS 2012)*, ID:6166, Toronto, Canada, August 27th-31th, 2012.
- Redondas, A, Rodríguez-Franco, J.J., Sierra M, Carreño V, "REGIONAL BREWER CALIBRATION CENTER-EUROPE". *GAW 2013 Symposium*, 18-20 March 2013 WMO Secretariat, Switzerland, Geneva, 2013.
- Redondas, A., Rodríguez-Franco J.J., Carreño, V., and Sierra, M., "Ten years of the Regional Brewer Calibration Center- Europe" *COST ACTION ES1207 EUBREWNET OPEN CONGRESS /14th WMO-GAW BREWER USERS GROUP MEETING EUBREWNET & WMO GAW*, Tenerife, 24-28 March 2014, 2014a.
- Redondas, A., Evans, R., Stuebi, R., Köhler, U., and Weber, M.: Evaluation of the use of five laboratory-determined ozone absorption cross sections in Brewer and Dobson retrieval algorithms, *Atmos. Chem. Phys.*, 14, 1635-1648, doi:10.5194/acp-14-1635-2014, 2014b.
- Rodríguez-Franco J.J., Redondas, A., Carreño, V., and Sierra, M., "Regional Brewer Calibration Center - Europe intercomparison campaigns: instrumental findings" *COST ACTION ES1207 EUBREWNET OPEN CONGRESS /14th WMO-GAW BREWER USERS GROUP MEETING EUBREWNET & WMO GAW*, Tenerife, 24-28 March 2014.

17.7 Staff

- Alberto Redondas Marrero (AEMET; PI in charge of RBCC-E)
- Virgilio Carreño (AEMET; Meteorological Observer-GAW Technician)
- Juan José Rodríguez (AEMET; Research Scientist)
- Marta Sierra (AEMET; Research Scientist)
- Dr Sergio Fabián León Luis (AEMET; Research Scientist)
- Bentorey Hernandez Cruz (ULL; Research Scientist)
- Ana Peris Morel (ULL; Research Scientist)
- Dr Alberto Berjón (AEMET; Research Scientist)

18 Calima Warning System

Mineral dust is a major contributor to the aerosol content in the atmosphere. Along with other aerosols, it plays a significant role in the Earth-Atmosphere energy balance by both direct and indirect effects. It also has adverse impacts on human health. This has been the principal motivation for the development of atmospheric dust forecasting systems. Thanks to dust forecasts, measures can be taken to protect population from the adverse effects of exposures to high concentrations of particulate matter. Forecasting systems are also very useful for policy makers to establish and modify air quality regulations.

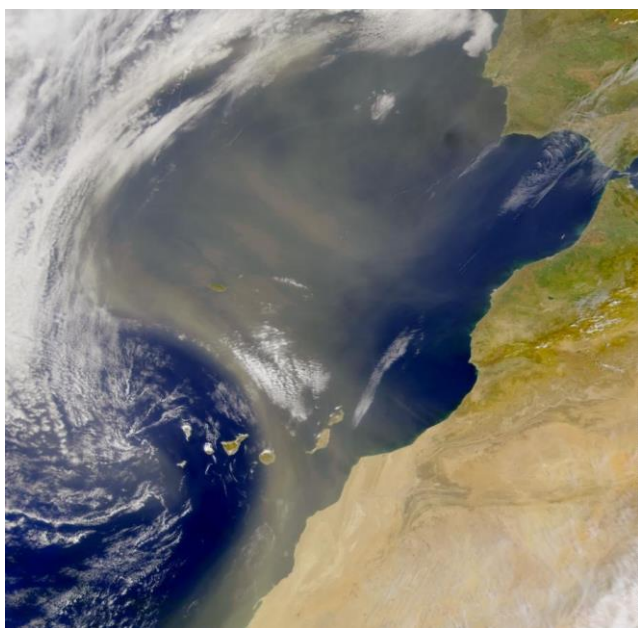

Figure 18.1. Dust intrusion impacting the Canary Islands and western Iberian Peninsula (MODIS-NASA).

One of the major worldwide sources of mineral dust is the Sahara desert. Due to its proximity to North Africa, Spain is frequently affected by Saharan dust intrusions. Among all natural sources of aerosols in Spain, African dust episodes have the biggest impact on air quality. Since February 2004, an African dust intrusions forecast and warning system has been fully operational in Spain. The “Calima” warning system is developed within the framework of a cooperation agreement between the Spanish Ministry of Agriculture, Food and Environment and the Spanish National Research Council (CSIC) to carry out the study and evaluation of air pollution by particulate matter and metals in Spain. “Calima” is a Spanish term referring to dust-laden haze.

18.1 Methodology and tools

Due to the geographic and climatic diversity of Spain, the territory has been divided into nine different geographical areas: seven areas for the Iberian Peninsula, one for the Balearic Islands in the Mediterranean Basin, and one for the Canary Islands in the Subtropical Northeast Atlantic region. For each of these areas a comprehensive analysis of the expected dust concentration and origin of the air masses is made every day, and a 24-h (72-h for weekends and Mondays) forecast is performed (MMA, 2012). Different numerical prediction models, forecast back-trajectories and remote sensing data are used following a phenomenological/intuition dichotomous forecasting method (Table 18.1).

The forecast is promptly posted in the CALIMA Warning System [website](#). Moreover, when an African dust outbreak is expected to affect at surface level in at least one of the geographical areas above mentioned, a forecasting bulletin is emitted both on the website and through an email list.

Table 18.1. Summary of forecasting tools used within the Calima Warning System.

Dust Models	Synoptic charts	Remote sensing	Airmass back-trajectories	Other tools
NAAPS (Marine Meteorology Division of the Naval Research Laboratory)	ECMWF	Meteosat Second Generation imagery	ECMWF forecast back-trajectories	Real time in-situ particulate matter concentrations (air quality networks across Spain)
BSC-DREAM8b v2.0 (Barcelona Supercomputing Center)	HIRLAM	—	HYSPLIT 4.0 forecast back-trajectories	Radiosoundings
Skiron (University of Athens)	—	—	—	—
NMMB-BSC/Dust (Barcelona Supercomputing Center)	—	—	—	—

An updated list of African dust episode dates occurred on each month of the current year and for each geographical area is also distributed. Users receiving this information by email are mostly air quality managers and researchers in the area of air pollution. At the present time, the distribution mailing list contains 195 email addresses.

Besides that information distributed through the aforementioned channels, some special forecasts are performed for measurements campaigns. The CALIMA Warning System has provided support for multiple campaigns carried out at IZO.

18.2 Summary of remarkable results during the period 2011-2014

African dust outbreak warnings for 179, 177, 152 and 162 days were emitted during the years 2011, 2012, 2013 and 2014, respectively. A verification of the CALIMA forecasts was performed for the year 2011 using contingency tables for each of the nine different geographical areas. Accuracy (fraction correct) was calculated as:

$$\text{Accuracy} = \frac{\text{hits} + \text{correct negatives}}{\text{total}} \quad (\text{Equation 18.1})$$

where hits is the number of events forecasted to occur that did occur and correct negatives is the number of events forecasted not to occur that did not occur.

Failures (number of events forecasted not to occur, but that did occur) and false alarms (number of events forecasted to occur, but that did not occur) were also calculated. Averaged values of accuracy, false alarms and false negatives across Spain for the year 2011 are shown in Fig. 18.2. The accuracy of the CALIMA Warning System was 89.47%, which can be considered quite good. The same percentage of false alarms and false negatives was found, 5.27% and 5.26%, respectively.

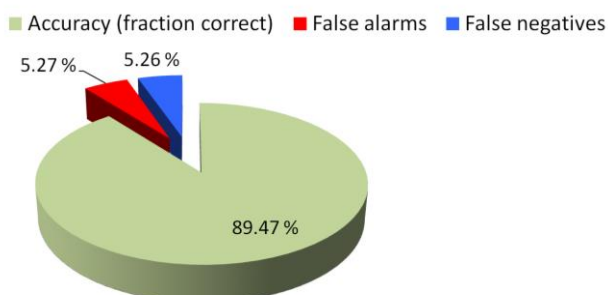

Figure 18.2. Verification of the CALIMA Warning System across Spain for the year 2011.

A verification of the CALIMA Warning System for the period 2012-2014 is currently being carried out.

Predictions and analysis of intrusion of dust on the Iberian Peninsula and the archipelagos have led to the drafting of some interesting scientific articles (e.g., Alonso-Pérez et al., 2012; Pey et al., 2012 and Salvador et al., 2014).

18.3 References

- Alonso-Pérez, S., E. Cuevas, X. Querol, J.C. Guerra, C. Pérez, African dust source regions for observed dust outbreaks over the Subtropical Eastern North Atlantic region, above 25° N. *Journal of Arid Environments*, 78, 100-109. doi: 0.1016/j.jaridenv.2011.11.013, 2012.
- MMA (Ministerio de Medio Ambiente, España), Identificación de episodios de transporte a larga distancia causantes de episodios de partículas en suspensión en España, Informes de Dirección General de Calidad y Evaluación Ambiental. 2012.
- Pey, J., Querol, X., Alastuey, A., Forastiere, F., Stafoggia, M., African dust outbreaks over the Mediterranean Basin during 2001-2011: PM10 concentrations, phenomenology and trends, and its relation with synoptic and mesoscale meteorology, *Atmos. Chem. Phys.*, 12, 28195-28235, doi:10.5194/acpd-12-28195-2012, 2012.
- Salvador, P., S. Alonso-Pérez, J. Pey, B. Artfñano, J. J. de Bustos, A. Alastuey, X. Querol (2014). African dust outbreaks over the western Mediterranean Basin: 11-year characterization of atmospheric circulation patterns and dust source areas, *Atmos. Chem. Phys.*, 14, 6759-6775, doi:10.5194/acp-14-6759-2014, 2014.

18.4 Staff

- Dr Silvia Alonso Pérez (CSIC/AEMET)
- Dr Xavier Querol (CSIC)
- Dr Jorge Pey (CSIC)
- Dr Noemí Pérez (CSIC)
- Dr Pedro Salvador (CIEMAT)

19 Sand and Dust Storm Centres

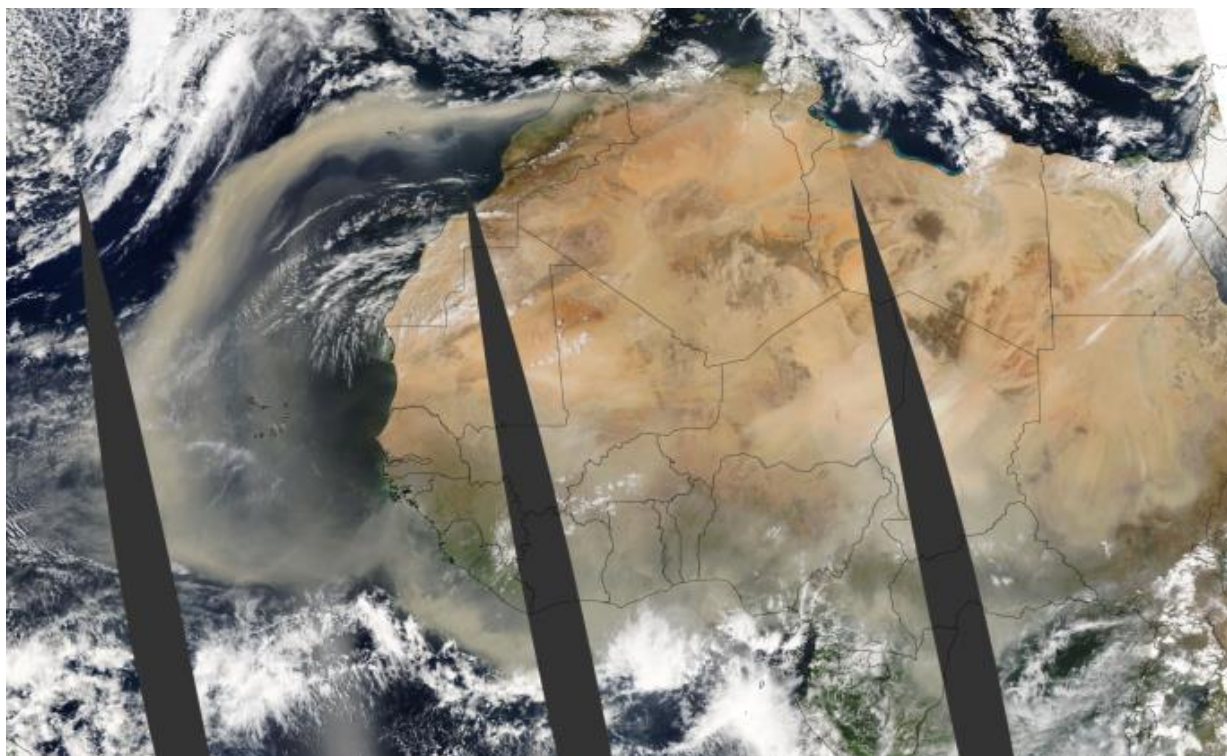

Figure 19.1. An immense dust storm blowing over central Northern Africa on 6 March 2004, imaged by the Moderate Resolution Imaging Spectroradiometer (MODIS). Credits: Jacques Desclotres, MODIS Rapid Response Team, NASA/GSFC.

When winds are strong, large amounts of sand and dust can be lifted from bare, dry soils into the atmosphere and transported downwind affecting regions hundreds to thousands of kilometres away (Fig. 19.1).

The IARC is actively involved in the strategic planning of activities, scientific advice on aerosols and dust observation, as well as in initiatives on capacity building and training of two Centers dedicated to Sand and Dust Storm activities: 1) the WMO Sand and Dust Storm Warning Advisory and Assessment System (SDS-WAS) Regional Center for Northern Africa, Middle East and Europe, and 2) the Barcelona Dust Forecast Centre (BDFC).

19.1 WMO Sand and Dust Storm Warning Advisory and Assessment System (SDS-WAS) Regional Center

The Sand and Dust Storm Warning Advisory and Assessment System (SDS-WAS) is a programme of the World Meteorological Organization with the mission to enhance the ability of countries to deliver timely and quality sand and dust storm forecasts, observations, information and knowledge to end users.

The Regional Centre for Northern Africa, Middle East and Europe (NA-ME-E) was established in 2007 to coordinate SDS-WAS activities within this region. The Centre, as a consortium of the Spanish State Meteorological Agency (AEMET) and the Barcelona Supercomputing Centre –

National Supercomputing Centre (BSC-CNS), soon evolved into a structure that hosted international and interdisciplinary research cooperation between numerous organizations in the region and beyond, including national meteorological services, environmental agencies, research groups and international organizations.

The Center's web portal (Fig. 19.2) became a place where visitors could find the latest dust-related observations and the most up-to-date experimental dust forecasts. The activities carried out by the SDS-WAS Regional Centre have been broadly disseminated in international workshops and conferences (Cuevas et al., 2013a; 2013b; 2014a; Terradellas et al., 2013a; 2013b).

A global observational network is crucial to any forecast and early warning system for real-time monitoring, validation and evaluation of forecast products, as well as for data assimilation. The main data sources are in-situ aerosol measurements performed in air quality monitoring stations, indirect observations (visibility and present weather) from meteorological stations, sun photometric measurements (e.g. AERONET network), lidar and ceilometers and satellite products.

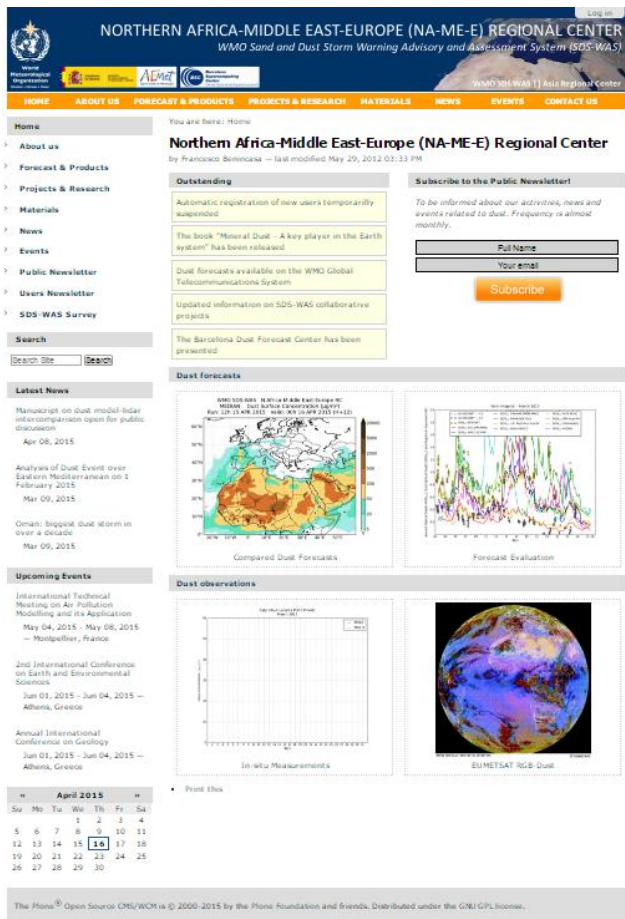

Figure 19.2. SDS-WAS Regional Center Web portal.

The exchange of forecast model products is a core part of the WMO SDS-WAS programme and the basis for the joint visualization and evaluation initiative. The web portal offers side-by-side dust forecasts (dust surface concentration and dust optical depth at 550 nm) issued by seven modelling systems as well as the multi-model median. The models are BSC-DREAM8b_v2, MACC, DREAM8-NMME-MACC, NMMB/BSC-Dust, MetUM, GEOS-5 and NGAC.

An important stage of any forecasting system is the evaluation of the out-coming products. The main goal is to assess whether the modelling systems successfully simulate the evolution of dust-related parameters. In addition, the evaluation improves the understanding of the models capabilities, limitations, and appropriateness for the purpose for which they were designed. The evaluation is performed by comparing the models forecasts with observational data. The dust optical depth (DOD) at 550 nm forecast by the models and multi-model median is compared with AERONET observations of aerosol optical depth (AOD) in monthly plots for 40 selected dust-prone stations. In addition to this near real time evaluation, a system to assess quantitatively the performance of the different models has been implemented. It yields evaluation scores computed from the comparison of the simulated DOD with the AERONET retrievals of AOD.

The SDS-WAS Regional Centre works toward strengthening the capacity of countries to use the observational and forecast products distributed in the framework of the WMO SDS-WAS programme in the partnership with National Meteorological and Hydrological Services (NMHSS) in the region and other relevant organizations. A detailed description of SDS activities by the SDS-WAS Regional Centre is given by Terradellas et al. (2014).

Within the activities of the SDS-WAS Regional Centre, the WMO released the report entitled "Establishing a WMO Sand and Dust Storm Warning Advisory and Assessment System Regional Node for West Asia: Current Capabilities and Needs" by Cuevas (2013c). The report was elaborated under the overall supervision of the WMO Atmospheric Research and Environment Branch, with the support of the United Nations Environment Programme Regional Office for West Asia.

19.1.1 SDS-WAS and MACC project

Monitoring Atmospheric Composition and Climate (MACC) operates and improves data-analysis and modelling systems for a range of atmospheric constituents that are important for climate, air quality and surface solar radiation. Product lines include the use of data records on atmospheric composition for recent years, data for monitoring present conditions and forecasts of the distribution of key constituents for a few days ahead. MACC is funded under the 7th Framework Programme of the European Union and provides the pre-operational atmospheric environmental service of the GMES initiative. This service complements the weather analysis and forecasting services provided by European and national organizations by addressing the composition of the atmosphere.

To provide air quality and atmospheric composition services, MACC-II uses a comprehensive global monitoring and forecasting system that estimates the state of the atmosphere on a daily basis, combining information from models and observations, and it provides a daily 5-day forecast. The global modelling system is also used to provide the boundary conditions for an ensemble of more detailed regional air quality models that are used to zoom in on the European domain and produce 4-day forecasts of air quality. The collaboration with MACC has enabled SDS-WAS to incorporate the MACC prediction system to the intercomparison and joint evaluation of dust models. On the other hand, SDS-WAS has provided a valuable external evaluation of the dust component of the MACC prediction system that has led to new ways for improvement.

SDS-WAS participated (through AEMET) in the MACC project providing information in a total of 17 reports in the period 2012-2014. These reports are available at the MACC Validation Reports [website](#). In addition to this important

participation in the MACC-II quarterly reports, the SDS-WAS was responsible for the relevant publication on MACC-II reanalysis validation using numerous independent satellite borne and ground-based dust observations (Cuevas et al., 2014b).

19.1.2 Capacity building activities

During 2012-2014 the following capacity building activities were carried out:

- II Lectures on Atmospheric Mineral dust (Barcelona, Spain, 5-9 Nov 2012)



- Training Course on the Use of Satellite Products for Agrometeorological Applications (Niamey, Niger, 19-23 Nov 2012)
- Training Course on the Use of Satellite Products for Agrometeorological Applications (Accra, Ghana, 10-14 Jun 2013)
- Workshop on Meteorology, Sand and Dust Storm, Combating Desertification and Erosion (Istanbul, Turkey, 28-31 Oct 2013)



- 3rd Training Course on WMO SDS-WAS products (satellite and ground observation and modelling of atmospheric dust) (Muscat, Oman, 8-12 Dec 2013)



- McIDAS tutorial with focus on atmospheric dust cases (Muscat, Oman, 15-16 Dec 2013)
- Training Course on the Use of Satellite Products for Agrometeorological Applications (Ouagadougou, Burkina Faso, 5-9 May 2014)
- 4th Training course on WMO SDS-WAS products (satellite and ground observation and modelling of atmospheric dust) (Casablanca, Morocco, 17-20 Nov 2014)



19.2 The Barcelona Dust Forecast Centre

In May 2013, in view of the demand of many national meteorological services and the good results obtained by the SDS-WAS, which proved the feasibility and the need to begin developing operational services beyond the scope of R&D, the 65th Session of the WMO Executive Council designated the consortium formed by AEMET and the BSC-CNS to create in Barcelona the first Regional Specialized Meteorological Centre with activity specialization on Atmospheric Sand and Dust Forecast (RSMC-ASDF). The Centre shall operationally generate and distribute predictions for Northern Africa (north of equator), Middle East and Europe.

The Barcelona Dust Forecast Centre (BDFC) prepares regional forecast fields using the NMMB/BSC-Dust model continuously throughout the year on a daily basis. The model consists of a numerical weather prediction model incorporating on-line parameterizations of all the major phases of the atmospheric dust cycle. It is run at a horizontal resolution of 0.1 degrees longitude per 0.1 degrees latitude for a domain covering Northern Africa, Middle East and Europe (25°W-65°E, 0°-65°N). This domain covers the main dust source areas in Northern Africa and Middle East, as

well as the main transport routes and deposition zones from the equator to the Scandinavian Peninsula. A description of the activities performed in 2014 by the BDFC is given in Terradellas et al. (2015). More information about the BDFC and current activities and operational dust forecasts can be found on the BDFC [website](#).

19.3 References

- Cuevas, E., J.M. Baldasano, X. Zhang, W. Sprigg, E. Terradellas, and S. Nickovic, SDS-WAS Research and Development activities, 6th meeting of the WWRP JSC, Geneva, 18-19 July 2013a.
- Cuevas, E., J.M. Baldasano, X. Zhang, W. Sprigg, E. Terradellas, S. Basart, S. Nickovic, SDS-WAS Research and Development activities, WMO-CAS-16 meeting, Antalya, Turkey, 20-26 November 2013b.
- Cuevas, E., Establishing a WMO Sand and Dust Storm Warning Advisory and Assessment System Regional Node for West Asia: Current Capabilities and Needs, WMO-No. 1121, Chair, Publications Board World Meteorological Organization (WMO), ISBN: ISBN 978-92-63-11121-0, December 2013c.
- Cuevas, E., E. Terradellas, J.M. Baldasano, Impactos del polvo atmosférico: SDS-WAS Regional Center for Northern Africa, Middle East and Europe, Presentation Ceremony of the WMO/CBS Barcelona Dust Forecast Center (BDFC), AEMET, Madrid, June 10th, 2014a.
- Cuevas, E., Camino, C., Benedetti, A., Basart, S., Terradellas, E., Baldasano, J. M., Morcrette, J.-J., Marticorena, B., Goloub, P., Mortier, A., Berjón, A., Hernández, Y., Gil-Ojeda, M., and Schulz, M.: The MACC-II 2007–2008 reanalysis: atmospheric dust evaluation and characterization over Northern Africa and Middle East, *Atmos. Chem. Phys. Discuss.*, 14, 27797-27879, doi:10.5194/acpd-14-27797-2014, 2014b.
- Terradellas, E, Baldasano, JM, Cuevas, E, Basart, S, Huneeus, N, Camino, C, Dunder, C, Benincasa, F., Evaluation of atmospheric dust prediction models using ground-based observations, European Geosciences Union (EGU) General Assembly 2013. *Geophysical Research Abstracts*, EGU2013-8274, Viena, Austria, 07-12 April, 2013a.
- Terradellas, E., E. Cuevas, and J.M. Baldasano, WMO Sand and Dust Storm Warning Advisory and Assessment System: Regional Center for Northern Africa, Middle East and Europe, GAW-2013 Symposium, Geneva, Switzerland, 18-20 March, 2013b.
- Terradellas, E., J. M. Baldasano, and E. Cuevas, (AEMET), Regional Center for Northern Africa, Middle East and Europe of the WMO Sand and Dust Storm Warning Advisory and Assessment System. Activity Report 2010-2012, Chair, Publications Board World Meteorological Organization (WMO), February, 2014.
- Terradellas, E., S. Basart, J.M. Baldasano, and E. Cuevas, Barcelona Dust Forecast Centre: WMO Regional Specialized Meteorological Centre with activity specialization on Atmospheric Sand and Dust Forecast. Activity Report 2014, Barcelona, 11 February 2015.

19.4 Staff

- Enric Terradellas (AEMET, Technical Director of the SDS WAS Regional Centre NA-ME-E, and the BDFC)
- Dr Emilio Cuevas (AEMET; Scientific Advisor)
- Dr José María Baldasano (UPC-BSC; Scientific Advisor)
- Dr Sara Basart (BSC; Research Scientist)
- Francesco Benincasa (BSC-AEMET; Technical support)
- Kim Serradell (BSC; Technical support)
- Dr Sergio Rodríguez (AEMET; Research Scientist)

20 North Africa AERONET/PHOTONS network



Figure 20.1. North African PHOTONS/AERONET network.

In 2008, AEMET launched the project ‘Sand and Dust Storm Early Warning System in the Magreb Region’ (SDS-Africa) to reinforce the observational capacity for mineral dust in Northern Africa. The main goal of the project, financed by the AECID, was to establish a ground-based network of sun photometers in selected locations of Northern Africa for detecting and monitoring dust storms.

This project has led to the creation of a ground-based network of PHOTONS/AERONET sun photometers in selected sites of Northern Africa (Algeria, Egypt, Morocco and Tunisia) being complemented by the AERONET stations in the Canary Islands (managed by the IARC) (Fig. 20.1, Table 20.1). Four instruments have been installed in the following GAW stations:

- Tamanrasset, Algeria, a strategic site in the heart of the Sahara to study and characterize the Saharan Air Layer (SAL).

- Cairo (Egypt) and Tunis (Tunisia), two strategic places for the monitoring and study of dust transport from the Sahara to the Eastern and Central Mediterranean.
- Ouarzazate, Morocco, on the south eastern slopes of the Atlas range and the edge of the Sahara desert, in the dust corridor to the North Atlantic.

The main goal of this project was to reinforce the ground-based observational system of the WMO Sand and Dust Storm Warning Advisory and Assessment (SDS-WAS) System for Northern Africa, Europe and Middle East hosted by Spain and managed by the consortium integrated by AEMET and BSC (See Section 19).

Table 20.1. Stations involved in the North Africa PHOTONS/AERONET network.

Station/Partner institution	Starting date	AERONET site
IZO (Spain)/AEMET	27 March 2003	Izana
SCO (Spain)/AEMET	22 July 2004	Santa Cruz Tenerife
Tamanrasset (Algeria)/Office National de la Météorologie (ONM)	29 September 2006	Tamanrasset_INM
Cairo (Egypt)/Egyptian Meteorological Authority (EMA)	26 April 2010	Cairo_EMA_2
Ouarzazate (Morocco)/Direction de la Météorologie Nationale (DMN)	10 February 2012	Ouarzazate
Tunis (Tunisia)/Institut National de la Météorologie (INM)	11 June 2013	Tunis Carthage

This observation network is being used for the Saharan Air Layer characterization (Guirado et al., 2014), satellite-based sensor validation and calibration, and for near-real time and a posterior dust modelling validation (See Section 19 and Cuevas et al., 2014). This project constitutes also a valuable contribution to the Aerosol WMO GAW Programme.

20.1 Capacity building

Approximately every 12-15 months, each Cimel instrument of the network is exchanged by a calibrated sensor under the AERONET-Europe Calibration Service (see Section 16). Furthermore, great attention has been paid to Capacity Building activities. During changes of Cimel instruments, we take the opportunity to perform short refreshing training courses to field operators. The capacity building missions carried out in the period 2012-2014 are detailed in Table 20.2.

Table 20.2. Capacity building activities conducted during 2012-2014.

Location	Date	Trained personnel
Ouarzazate Met station (Morocco)	9-12 February 2012	Personnel in charge of the Cimel sunphotometer and personnel from the DNM-Casablanca
Ouarzazate Met station (Morocco)	17-21 March 2013	Personnel in charge of the Cimel sunphotometer and personnel from the DNM-Casablanca
INM Headquarters, Tunis-Carthage (Tunisia)	10-14 June 2013	Arbi Trifi, Faycal Elleuch, Mounir Souii, Fekri Ghorbel and Ilyes Zarrouk, Tunis-Carthage
Izaña (Spain)	24-28 June 2013	Zeinab Salah Mahmoud (Egypt), Ahmed AbdelHamid Ibrahim (Egypt), Faycal Elleuch (Tunisia), Ahmed Hmam (Tunisia)
Algiers (Algeria)	10-12 December 2013	Lahouari Zeudmi and a second technician, Tamanrasset station (Algeria)
Izaña (Spain)	22-26 September 2014	Souhail Krichen, Tunis-Carthage station (Tunisia)
Izaña (Spain)	17-21 November 2014	Abdelhamid Gouda Elawadi, Cairo_EMA_2 station (Egypt)
Izaña (Spain)	1-5 December 2014	Lahouari Zeudmi and Mohamed Kharef, Tamanrasset station (Algeria)

20.2 References

- Cuevas, E., Camino, C., Benedetti, A., Basart, S., Terradellas, E., Baldasano, J. M., Morcrette, J.-J., Marticorena, B., Goloub, P., Mortier, A., Berjón, A., Hernández, Y., Gil-Ojeda, M., and Schulz, M.: The MACC-II 2007–2008 reanalysis: atmospheric dust evaluation and characterization over Northern Africa and Middle East, *Atmos. Chem. Phys. Discuss.*, 14, 27797-27879, doi:10.5194/acpd-14-27797-2014, 2014.
- Guirado, C., Cuevas, E., Cachorro, V. E., Toledano, C., Alonso-Pérez, S., Bustos, J. J., Basart, S., Romero, P. M., Camino, C., Mimouni, M., Zeudmi, L., Goloub, P., Baldasano, J. M., and de Frutos, A. M.: Aerosol characterization at the Saharan AERONET site Tamanrasset, *Atmos. Chem. Phys.*, 14, 11753-11773, doi:10.5194/acp-14-11753-2014, 2014.

20.3 Staff

Dr Emilio Cuevas (AEMET; PI of the network)

Dr Ashraf Zakey (EMA, Egypt; Co-PI Cairo_EMA_2 station)

Mohamed Mimouni (ONM; Algeria; Co-PI Tamanrasset_INM station)

Faycal El Euch (INM; Tunisia; Co-PI Tunis-Carthage station)

Taoufik Zaidouni (DMN; Morocco; Co-PI Ouarzazate station)

Carmen Guirado Fuentes (UVA/AEMET; Network technical manager)

Ramón Ramos (AEMET; Head of Infrastructure)

21 GAW Ushuaia twinning programme

The State Meteorological Agency of Spain, through the Izaña Atmospheric Research Center, the Argentinian Meteorological Service (SMN), the Spanish National Institute for Aerospace Technology (Instrumentation and Atmospheric Research Branch) and the Government of the province of Tierra del Fuego (Argentina), initiated a programme on 14 April 2008 for total column atmospheric ozone monitoring from the Global Ushuaia GAW station (Argentina; 55°S and 68°W). This programme complements the ozonesonde programmes performed on the Antarctic Peninsula by the Finnish Meteorological Institute at Marambio station (Argentinian Base; 64°S, 57°W), and by the INTA at Belgrano station (Argentinian Base; 78°S, 34°W).



Figure 21.1. Argentinian-Spanish team (top) during the first ozone-sonde launching at Ushuaia GAW station on 14 April 2008.

This programme provides information about the impact of the Antarctic ozone hole on the southern part of South America. The data from Ushuaia are transmitted to the WMO World Ozone and UV Data Centre in Toronto, Canada, and are available to the ozone international community of scientists and other interested parties. The data are also used in the WMO Antarctic ozone bulletins, published from August to November every year.

An example of the ozone-hole period seen from Ushuaia's ozone vertical profiles, and its impact on Ushuaia in 2013 is shown in Fig. 21.2.

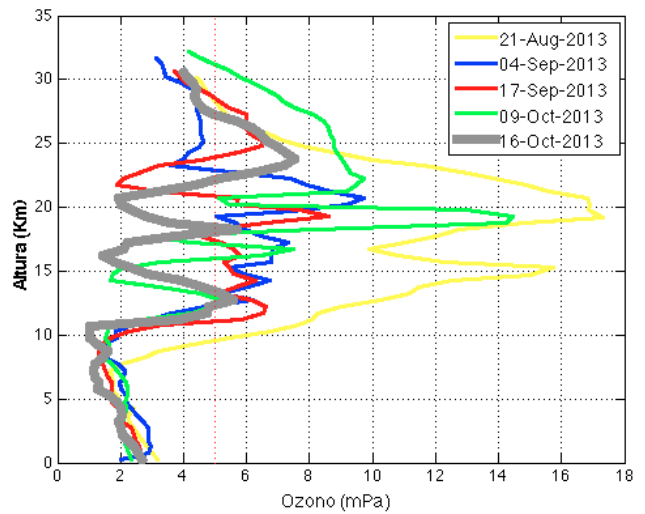

Figure 21.2. Ozone profiles over Ushuaia (Argentina) between 21 August – 16 October 2013. Very low ozone concentrations between 15 and 25 km altitude are observed from 4 September 2013.

21.1 Staff

Eng. Manuel Cupeiro (SMN, Director of the GAW Ushuaia station)

Eng. Ricardo Sánchez (SMN, Ozone Programme Manager)

Dr Emilio Cuevas (AEMET, PI of the Ushuaia O₃ sonde Programme)

Dr Margarita Yela (INTA; Co-PI of the Ushuaia O₃ sonde Programme)

Ramón Ramos (AEMET, logistics and instrumentation)

Sergio Afonso (AEMET, ozonesonde launching technician)

22 GAW Tamanrasset twinning programme

In 2006, the “GAW-Twinning” between IZO and Tamanrasset GAW stations was initiated with the Saharan Air Layer Air Mass characterization (SALAM) project. This is part of a cooperation programme between the l’Office Nationale de la Météorologie (ONM, Algeria) and AEMET. In September 2006 the AERONET and PHOTONS / RIMA Tamanrasset-AEMET Cimel station was installed (See Section 20).



Figure 22.1. Group of participants in the installation campaign within the GAW-Sahara project at the South Regional Meteorological Center (Tamanrasset). First line from left to right: M. Mimouni (ONM), R. Ramos (AEMET), A. Ouladichir (ONM), E. Cuevas (AEMET), M. Kharef (ONM) and V. Carreño (AEMET). Second line from left to right: O. Bouziane (ONM), J. Rodríguez-Franco (AEMET), F. Mohamed Salah (ONM), B. Lamine (ONM), A. Berjón (AEMET) and B. Sida Lamine (ONM).



Figure 22.2. The Cimel team with the Cimel#547 sunphotometer. From left to right: R. Ramos (AEMET), A. Berjón (AEMET), F. Mohamed Salah (ONM), M. Kharef (ONM) and O. Bouziane (ONM).

The twinning was reinforced with the installation at Tamanrasset of the Cimel#547 sunphotometer (Fig. 22.2) and the double Brewer Spectrophotometer #201 (MARK-III) (Fig. 22.3). In addition, a multifilter Norwegian Institute for Air Research (NILU) radiometer was installed at the high-altitude Assekrem GAW station (2730 m a.s.l) 80 km north of Tamanrasset (Fig. 22.4) in October 2011. Both facilities are part of the l’Office Nationale de la Météorologie (ONM; Algeria).



Figure 22.3. The Brewer team with the Brewer#201 double spectrophotometer: From left to right: O. Bouziane (ONM), F. Mohamed Salah (crouched) (ONM), M. Kharef (ONM), B. Sida Lamine (ONM), J. Rodríguez-Franco (AEMET), V. Carreño (AEMET), and B. Lamine (ONM).

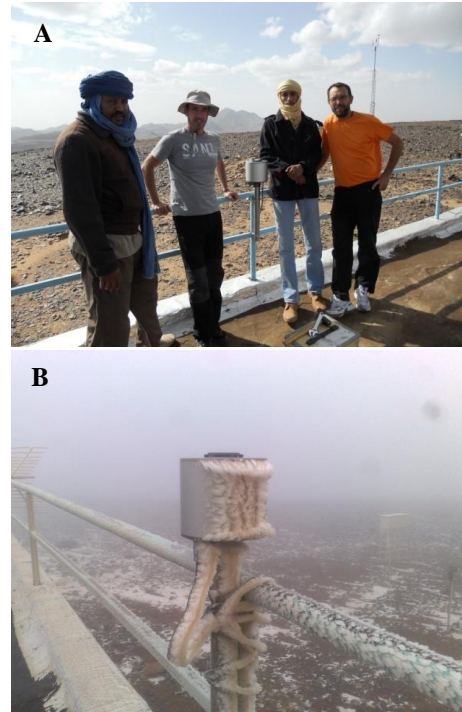

Figure 22.4. A) The NILU-UV6 multifilter radiometer installation team at Assekrem. From left to right: A. Omar (ONM), V. Carreño (AEMET), B. Sida Lamine (ONM) and R. Ramos (AEMET). B) The NILU-UV6 radiometer at Assekrem after snow and frozen rime storm on 28 February 2014 (Courtesy of M. Mimouni).

The Spanish Agency for International Development Cooperation has financed the project entitled “Global Atmosphere Watch in the Maghreb-Sahara Region” (GAW-Sahara) through a WMO Trust Fund.

An operational Dobson (#11; WMO station code 002) spectrophotometer has been operating at Tamanrasset since April 1994. This station is now one of the few sites in the world where permanent and long-term intercomparison between the Dobson, the Brewer and the present and future satellite-based sensors could be performed on a routine basis. This initiative has been strongly recommended by the WMO Ozone Scientific Advisory Group and will be a unique contribution to the total ozone global network Quality Assurance.

In addition, the installation of the NILU multifilter radiometer at Assekrem station provides UV radiation, Photosynthetic Active Radiation (PAR) and total column ozone at a high-altitude site in the middle of the Sahara. The Brewer at Tamanrasset and the NILU at Assekrem will also fill a current big gap of spectral UV observations in this region. Routine validation of new satellite-based sensors is one of the main goals of this programme.

The Brewer#201 at Tamanrasset is integrated into the Iberonesia network, managed by the Regional Brewer Calibration Center for Europe (RBCC-E; PI: Alberto Redondas) hosted by the Izana Atmospheric Research Center (See Section 17).

22.1 References

Guirado, C., Cuevas, E., Cachorro, V. E., Toledano, C., Alonso-Pérez, S., Bustos, J. J., Basart, S., Romero, P. M., Camino, C., Mimouni, M., Zeudmi, L., Goloub, P., Baldasano, J. M., and de Frutos, A. M.: Aerosol characterization at the Saharan AERONET site Tamanrasset, *Atmos. Chem. Phys.*, 14, 11753-11773, doi:10.5194/acp-14-11753-2014, 2014.

22.2 Staff

Dr Emilio Cuevas (AEMET, PI of the Tamanrasset-Izaña twinning)

Alberto Redondas (AEMET, PI of the Ozone and UV Programme)

Ramón Ramos (AEMET, logistics and instrumentation)

Carmen Guirado Fuentes (UVA/AEMET; AERONET-Europe Calibration Centre)

Virgilio Carreño (AEMET; Meteorological Observer-GAW Technician)

Juan José Rodríguez (AEMET; Research Scientist)

23 WMO CIMO Testbed for Aerosols and Water Vapour Remote Sensing Instruments

The mission of the Commission for Instruments and Methods of Observations (CIMO) is to promote and facilitate international standardisation and compatibility of instruments and methods of observations used by Members, in particular within the WMO Global Observing System, to improve quality of products and services of Members and meet requirements (see [Report](#) from the President to Cg-XV (2007), [Report](#) from the President to Cg-XVI (2011) and [Report](#) from the President to Cg-XVII (2015)).

CIMO-XV (2010) decided to establish CIMO Testbeds and Lead Centres to promote collaboration between CIMO and relevant NMHSs in testing, development and standardization of meteorological instruments and systems performance for the benefit of all WMO Members. It would utilize and build on both existing and state-of-the-art facilities and specific expertise available at NMHSs for the provision of guidance to all WMO Members.

CIMO XVI nominated Izaña Atmospheric Observatory as WMO-CIMO Testbed for Aerosols and Water Vapour Remote Sensing Instruments. The CIMO Testbeds are intended to promote collaboration between WMO and the National Meteorological Services for the testing, development and standardization of meteorological instruments and evaluation of the performance of the observing systems. Thus, they aim to promote the advancement of observing systems of WMO member countries through its Integrated Global Observing System (WIGOS). It is also expected that Testbeds centres can play a decisive role in the effort of WMO to reduce the differences between countries, favouring the completion of training and capacity building through specific collaborations with stations and observatories in developing countries. The General Terms of Reference for the CIMO Testbeds for Ground based Remote-sensing and In-situ Observations (CIMO TB) can be found at the [Terms of Reference of CIMO Testbeds](#).

23.1 Main objectives and activities of the Izaña Testbed

The main ongoing activities of the Izaña Atmospheric Observatory Testbed are related to instrument validation,



Figure 23.1. View of the radiation/aerosols instruments on the instrument terrace, IZO.

development of new methodologies and devices for aerosol observations (Fig. 23.1). Some of these activities are described in detail in Section 24 (Technological Projects).

- Development and evaluation of a new Triple photometer (Cimel CE318T; for sun, sky and lunar observations) to obtain day and night aerosols optical properties and water vapour in the atmospheric column, which might complement/replace in the future the classical CE318 sunphotometer used in AERONET. This development is being performed in collaboration with Cimel Electronique (France) (See Section 24.1, Cimel Electronique Lunar Photometer).
- Development of methodologies to improve night-time LIDAR observations by using AOD measured with lunar photometry. This is made in collaboration with LOA (CNRS-University of Lille, France) (Barreto et al., 2014).
- Development of a methodology envisaged to obtain automated and operational vertical extinction from lidar in two layers (Marine Boundary layer and Free Troposphere) using AOD information from AERONET stations at sea level and 2400 m a.s.l.
- Development and testing of a new Total Sky camera envisaged to detect clouds and dust, in collaboration with SIELTEC Canarias (see <http://sonaspecs.zohosites.com/>).
- Development of the new low-cost device with high automation and easy maintenance SIELTEC Digital Sky Colour Radiometer (SIELTEC-DSCR). This instrument is a prototype developed jointly with SIELTEC Canarias S.L. company to measure the intensity of zenith sky radiation in five wavelengths to derive total column aerosols/dust (see Section 24.3 Sieltec Digital Sky Colour Radiometer, and Almansa et al. (2014)).
- Testing of the new Precision Solar Spectroradiometer developed at PMOD/WRC to eventually replace current filter based sunphotometers for long-term aerosol optical depth and absolute solar irradiance measurements within the WMO GAW programme.

23.2 Other calibration and validation related activities

At IZO, 70 Calitoo sun photometers (Fig. 23.2) were calibrated during 7-9 October 2014. This small educational sun photometer has been manufactured by TENUM and developed under the scientific and technical supervision of Dr Phillippe Goloub and Eng. Luc Blarel from the Laboratoire d'Optique Atmosphérique (LOA; CNRS-University of Lille). Calitoo instruments are involved in the Global Learning and Observations to Benefit the Environment (GLOBE) program, which is a worldwide hands-on, primary and secondary school-based science and education program.



Figure 23.2. Calitoo sun photometer.

After manufacturing, the sun photometers must be periodically calibrated to provide trustable AOD measurements. The optimal calibration conditions of IZO allowed the calibration of these 70 Calitoo sun photometers, which will be distributed between education centres in France. One of these instruments will be utilized in experimental campaigns at IARC in the future and educational and dissemination activities.

23.3 Future activities

- Training course on sunphotometry to operators of PHOTONS/AERONET colleagues of Egypt, Tunisia, Algeria and Morocco in 2015 and 2016.
- Training course on Cimel sunphotometer and colour index radiometer is planned for technicians and observers working at the SDS-WAS observational network in North Africa in 2016, financed by a special Trust Fund for the African Centre of Meteorological Application for Development (ACMAD).
- Test of a new 2-wavelength lidar from Cimel Electronique (2016).
- Complete development of the new low-cost device with high automation and easy maintenance SIELTEC-

DSCR (SIELTEC Digital Sky Color Radiometer), including calibration methods, cloud screening, algorithms to determine dust AOD and PWV, and corresponding external validation against AERONET and GAW-PFR, by the end of 2015.

- Continue testing the new Precision Solar Spectroradiometer developed at PMOD/WRC (from April 2015).
- Implement a new CCD stellar photometer for AOD determination during the night (2016).
- Development of the calibration methodology for the CE318T (triple) photometer and measurement (AOD, AE and water vapour) validation against external references (AERONET, GAW-PFR, stellar photometer, and EUMETNET GPS Water Vapour Programme (EGVAP)).

23.4 References

- Almansa, F., E. Cuevas, C. López, A. Barreto, A. De Frutos, Aerosol optical depth inferred from zenith sky measurements using a new multifilter radiometer, Book of Abstracts, p 17, International Conference on ATMOSPHERIC DUST, Castellana Marina, Italy, June 1-6, 2014.
- Barreto, A., E. Cuevas, A. Mortier, P. Goloub, T. Podvin, L. Blarel, V. Choliy, and Y. Hernández, Nighttime characterization of AOD and water vapor using lunar photometry. Synergies with Lidar technique, WMO-TECO/CIMO-16, Commission for Instruments and Methods of Observations (CIMO), St. Petersburg, Russian Federation, July 7-9, 2014.

23.5 Staff

- Dr Emilio Cuevas (AEMET; PI of Testbed)
Ramón Ramos (AEMET; Head of Infrastructure)
Pedro Miguel Romero Campos (AEMET; Research Scientist)
Carmen Guirado Fuentes (UVA/AEMET; Research Scientist)
Dr Africa Barreto (CIMEL/AEMET; Research Scientist)
Antonio Fernando Almansa (CIMEL/AEMET; Research Scientist)
Dr Rosa García (UVA/AEMET; Research Scientist)
Dr Omaira García (AEMET; Research Scientist)

24 Technological Projects

24.1 Cimel Electronique Lunar and Triple Photometer

The development of a new methodology for nocturnal aerosol measurements and calibrations using lunar photometer prototypes, is a collaboration project between Cimel Electronique company and the Izaña Atmospheric Research Centre.



Figure 24.1. Two CE-318U Lunar photometer prototypes tracking the moon at IZO.

In a first stage, two prototypes of a new instrument developed by Cimel Electronique for lunar photometry (trade name CE-318U photometer) have been specifically designed to track the moon and to perform automatic lunar irradiance measurements (Fig. 18.1). These instruments were installed at IZO in order to characterize their performance, to develop a technique envisaged to obtain absolute calibrations and reliable validations against reference instruments.

AOD is the standard parameter commonly used in the literature to estimate aerosol loading in the atmosphere through ground-based observations. This operation is carried out continuously and globally during daytime using sunphotometers, such as the Cimel CE-318 operating in AERONET (Holben et al., 1998). The main constraint in sun photometry is that the information inferred is limited to the daylight period. Therefore, important gaps in the current ground-based networks during nighttime are preventing the monitoring of aerosol transport, the characterization of aerosol at high latitude locations, given the extended periods of darkness in wintertime, or a complete study of the aerosol diurnal cycle. In addition, precipitable water vapour (PWV) monitoring is required for climate studies. Thus, nocturnal photometry is currently the missing tool to expand the actual databases based solely on daytime observations. Despite its importance, nocturnal photometry has been far from a standardized technique for regional or global networks. As Herber et al. (2002) and Berkoff et al. (2011) suggested, important obstacles existed when aerosol properties are inferred at nighttime, leading to significant uncertainties compared to the accuracy reached using sunphotometry data.

The Lunar Photometer technological project was established in 2011 between Cimel Electronique and IARC to develop a new instrument as well as new strategies to tackle this problem, enabling using the moon as a ground-based remote technique for investigating atmospheric aerosol properties and water vapour content. As a result of this collaboration two new instruments were developed: CE-318U, the first lunar Cimel prototype, and CE-318T, the final product which combines the former sun photometer CE-318 with the CE-318U for nocturnal mode. The CE-318T is therefore able to perform both day and nighttime observations. In essence, this new lunar photometer combines the features of the standard Cimel sunphotometer

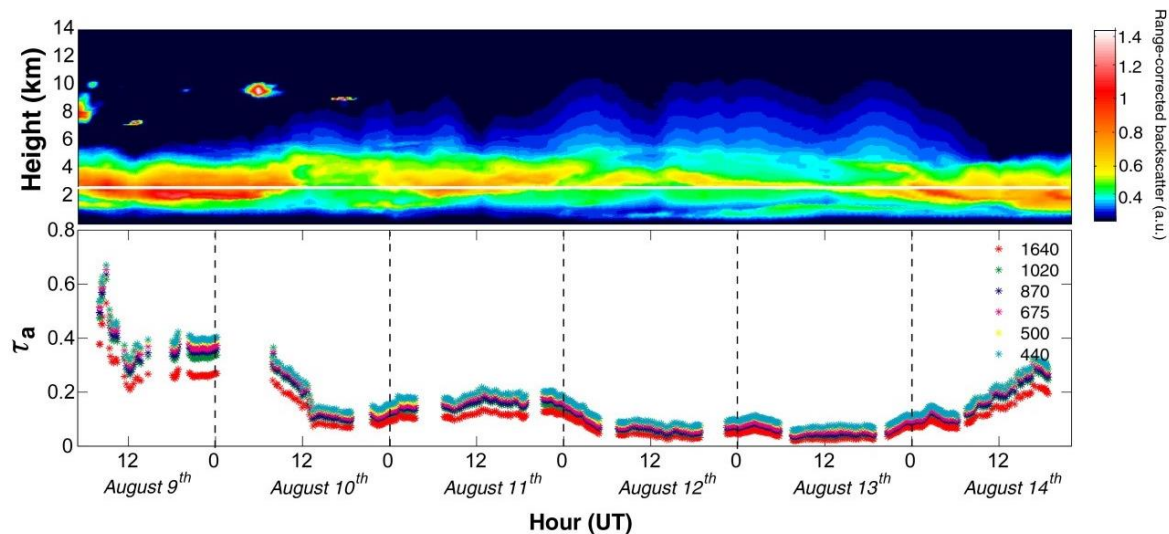

Figure 24.2. AOD (τ_a) evolution during six days and five nights in August 2011, using AERONET data for daytime and lunar CE-1 data for nocturnal period. MPL corrected backscatter cross-sections obtained at SCO in upper panel. The white line represents the Izaña Atmospheric Observatory altitude. Figure reprinted from Barreto et al. (2013a).

with a higher signal-to-noise ratio, necessary to capture the low incoming energy from the moon.

It performs nocturnal measurements with maximum gain and an approximate field of view of 1.29° at eight nominal wavelengths of 1640, 1020, 938, 937, 870, 675, 500 and 440 nm. Regarding the new CE-318T version (denoted hereafter as “Triple”), enhanced features allow three different measurement types using the same device: spectral direct sun and moon in addition to spectral sky radiances at daytime.

IARC CE-318U observations started in July 2011 with the first two prototypes installed at IZO. A total of seven prototypes were deployed in IARC during 2011 and 2012. The CE-318Ts were first installed at IARC in 2014. IARC is now considered a calibration center for CE-318U and CE-318T Langley calibration as well as for common sun photometers CE-318.

The required new methodology for lunar photometer calibration was also introduced as a result of this technological project. The new Lunar Langley Method for absolute calibration at nighttime (Barreto et al., 2013a) modifies the usual Langley technique to be applied to variable illumination conditions, as is the case of moon’s illumination. CE-318U technical performance as well as the new methodology were analysed in Barreto et al. (2012; 2013a; 2013b). Fig. 18.2 shows the daily AOD evolution using the Lunar Langley Method in a six-day and five-night period in August 2011, in which several Saharan dust intrusions occurred at IZO. The changes in aerosol concentrations are well captured by CE-318U, showing an accuracy within the AOD accuracy limit established in AERONET (± 0.01 for longer wavelength channels and ± 0.02 for those centered at 440 nm and 500 nm). In addition, a 4-wavelength GAW PFR developed by the World Optical Depth Research and Calibration Center (WORCC) of the PMOD World Radiation Center (WRC) was used as an additional reference to validate these results.

Regarding PWV, an intercomparison study between CE-318U PWV and Global Positioning System (GPS) PWV was developed by Barreto et al. (2013b). This comparative study using quasi-simultaneous nighttime PWV from Lunar Cimel and ultra-rapid GPS data at IZO during July and August 2011, showed high correlation coefficients between the two datasets as well as reduced differences (< 0.02 cm), standard deviations (up to 0.14 cm) and RMSE < 0.19 cm (Fig. 18.3). A subsequent comparison with nighttime RS92 radiosondes PWV data showed also a good agreement with the Lunar Cimel CE-318U PWV data. These results demonstrate the ability of this lunar photometer to obtain accurate and continuous PWV measurements at night.

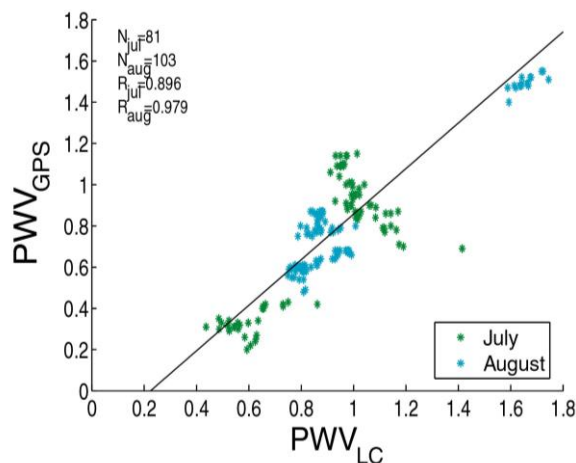

Figure 24.3. Scatterplots of PWV extracted from Lunar Cimel CE-318U (LC) and GPS ultra-rapid orbits (in cm) for channels centered at 938nm, during July and August, 2011. The number of pairs as well as the correlation coefficient (R) for each month are shown. Figure reprinted from Barreto et al. (2013b).

In spite of the encouraging results previously showed, it is necessary to refine the lunar irradiance model RObotic Lunar Observatory (ROLO), developed by Kieffer and Stone (2005), currently used in moon photometry calculations. A high-precision model will soon be available for moon photometry users from the U.S. Geological Survey (USGS). This improved lunar irradiance model will serve to significantly reduce the uncertainties associated to extraterrestrial lunar irradiance term. It is also necessary to design a more refined and simple procedure to transfer the absolute Lunar Langley calibration to field instruments.

Finally, further developments should be oriented to estimate the CE-318T accuracy under a wide range of moon illumination conditions in comparison to other reference instruments. To do this, two field campaigns were carried out in 2014 at IZO and Granada. The Izaña campaign involved the intercomparison of the CE-318T instrument in sun mode with the Precision Solar Spectroradiometer WRC prototype. The Granada campaign was focused on the validation of the CE-318T performance at nighttime by an intercomparison with a stellar photometer. Results from these two campaigns will allow for a comprehensive assessment of lunar photometry performance.

Lunar photometry is being rapidly developed thanks to the boost of two specific research communities: 1) atmospheric aerosol research in polar regions (due to long periods with no sunlight) and 2) the lidar research community, as it significantly improves the optical extinction vertical profiles from lidar-lunar photometer synergy during nighttime (Barreto et al., 2014a).



Figure 24.4 Participants of the AERONET Workshop held at the University of Valladolid, Sciences Faculty in October 2014.

Future steps in the development of the CE-318T and the calibration strategy were presented during the internal AERONET Workshop held in Valladolid (Spain) in October 2014 (Fig. 18.4) (Barreto et al., 2014b).

24.1.1 References

- Barreto, A., E. Cuevas, B. Damiri, P. M. Romero, C. Guirado, Y. Hernández, and M. Gil: A new lunar photometer to characterize aerosol properties and atmospheric water vapor at nighttime, TECO-2012, WMO Technical Conference on Meteorological and Environmental Instruments and Methods of Observation, Brussels, Belgium, 16-18 October, 2012.
- Barreto, A., E. Cuevas, B. Damiri, T. Berkoff, A. J. Berjón, Y. Hernández, F. Almansa and M. Gil: A new Method for nocturnal aerosol measurements with a lunar photometer prototype, Atmospheric Measurement Techniques. 6, 585-598, doi: 10.5194/amt-6-585-2013, 2013a.
- Barreto, A., Cuevas, E., Damiri, B., Romero, P. M., and Almansa, F.: Column water vapor determination in night period with a lunar photometer prototype, Atmos. Meas. Tech., 6, 2159-2167, doi: 10.5194/amt-6-2159-2013, 2013b.
- Barreto, A., E. Cuevas, A. Mortier, P. Goloub, T. Podvin, L. Blarel, V. Choliy, and Y. Hernández: Nighttime characterization of AOD and water vapor using lunar photometry. Synergies with Lidar technique, TECO-2014, WMO Technical Conference on Meteorological and Environmental Instruments and Methods of Observation, Russia, 7-9 July, 2014a.
- Barreto, A., E. Cuevas, M. Canini, B. Damiri, A. Almansa, and F. Maupin, Lunar Calibration, AERONET Workshop, Valladolid, October 14-17, 2014b.
- Berkoff, T. A., Sorokin, M., Stone, T., Eck, T. F., Hoff, R., Welton, E., and Holben, B.: Nocturnal aerosol optical depth measurements with a small-aperture automated photometer using the moon as a light source, J. Atmos. Ocean. Tech., doi: 10.1175/JTECH-D-10-05036.1, 2011.
- Herber, A., Thomason, L. W., Gernandt, H., Leiterer, U., Nagel, D., Schulz, K., Kaptur, J., Albrecht, T., and Notholt, J.: Continuous day and night aerosol optical depth observations in the Arctic between 1991 and 1999, J. Geophys. Res., 107 (D10), 4097, 13 PP., doi: 10.1029/2001JD000536, 2002.
- Holben, B. N., Eck, T. F., Slutsker, I., Tanré, D., Buis, J. P., Setzer, A., Vermote, E., Reagan, J. A., Kaufman, Y. J., Nakajima, T., Lavenu, F., Jankowiak, I. And Smirnov A.: AERONET- A

federated instrument network and data archive for aerosol characterization, Rem. Sens. Environ., 66, 1-16, 1998.

Kieffer, H. H., and Stone, T. C.: The spectral irradiance of the moon, The Astronomical Journal, 129, 2887-2901, 2005.

24.1.2 Staff

The Lunar Photometer research group is composed of the following researchers and specialist technicians from the IARC-AEMET and Cimel Electronique:

Dr Africa Barreto (CIMEL/AEMET)

Dr Emilio Cuevas (AEMET)

Dr Stephane Victori (CIMEL)

Eng. Marius Canini (CIMEL)

Antonio Fernando Almansa (CIMEL/AEMET)

24.2 SIELTEC SONA All-Sky Camera and Cloud Nowcasting



Figure 24.5. Image of SONA V3i at IZO.

24.2.1 Background

In 2002, the IARC installed at IZO the first commercial YES All-Sky camera. The image acquisition was based on sky pictures taken every 10 minutes. Nevertheless, this camera had several limitations: image quality was not suitable to discriminate the type of clouds nor to identify thin cirrus or night clouds with moonlight. Moreover, the commercial software version provided with the camera only allowed detection by using “oktas over total clouds”, with some strong limitations due to the shadow bandwidth.

Several years later, and after many storms and adverse weather, the camera suffered such damages that it was irreparable, so we decided to design and construct our own camera based on the experience gained with the YES camera. SIELTEC CANARIAS, S.L., at that time a small company, started to perform small instrumental developments with us, and undertook the development of a

new All-Sky camera under our requirements and recommendations, with a much more robust design and, at the same time, higher technical features and performance, that would be developed and tested in Tenerife under IARC supervision.

After several months of hard work, the final output was named SONA (Sistema de Observación de Nubes Automático) camera, an Automatic Cloud Observation System which has been exclusively designed to solve some of the major problems of other cameras at a very low cost in comparison with other commercial cameras.

24.2.2 The Automatic Cloud Observation System

The first version of SONA comprises an All-Sky imager with the following hardware: CCD sensor with Bayer filter and resolution 640x480 pixels resolution, 8 bit, colour response from 400 to 700 nm and monochrome response from 400 to 1000 nm. This camera is inside durable aluminium housing. CCD looks at the sky through a borosilicate dome. The system incorporates a rotating shadow band to protect the sensor from direct sunlight. The control electronics is safe against lightning. The operating temperature is from -10° to $+50^{\circ}$ C thanks to its cooling/heating system. Other camera features are:

- Rate: fast frame rates (up to 70 fps).
- Adjustable JPEG compressed still-images or live MJPEG streaming video.
- Transfer of images via FTP, RTP or HTTP.
- Camera control via HTTP, XML-RPC, Telnet.
- Automatic sliding IR cut filter.

The SONA all-sky camera is now used by 13 scientific institutions in Spain. At present, the IARC runs two SONA cameras at IZO and SCO to provide ancillary information to the Radiation and Column Aerosols Programmes, and it is also useful for astronomical activities at the Instituto de Astrofísica de Canarias, tourism and sportsmen (especially for paragliding). Images of the SONA camera at IZO are posted in near-real time at the web cam section of the IARC web site. A SONA 5-minute image database at IZO has been available since September 2008.

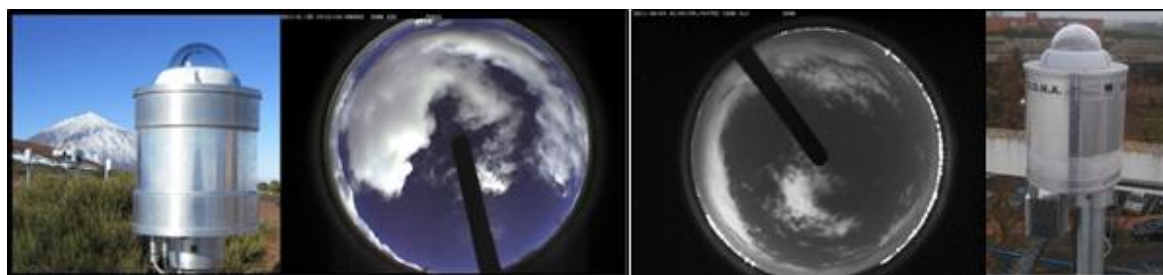

Figure 24.6. Left: Image of SONA V3i, with its characteristic aluminium housing, the dome and the shadow band inside the dome. Center: Sky image taken by SONA during daytime and nighttime, respectively. Right: SONA V6.

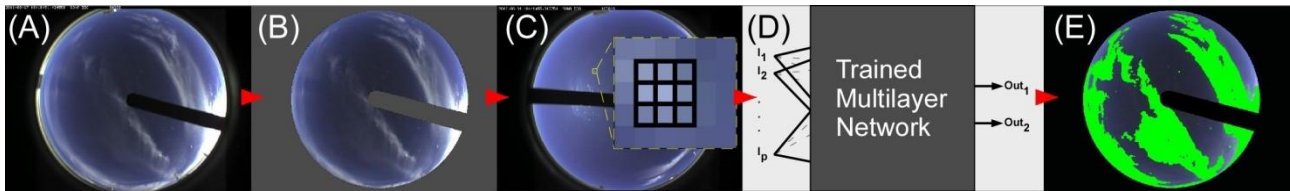

Figure 24.7. Cloud detection process steps. (A) Original image. (B) Masked image. (C) Algorithm analyses sky pixels and extracts input parameters. (D) Neural network generates the type of pixel. (E) Output image with cloud pixels marked as green.

24.2.3 Summary of remarkable results during the period 2012-2014

2012: Cloud cover estimation algorithm

Cloud cover characterization in sky images is a complex problem. Many variables related with the sky such as luminosity, sun position, cloud distribution, types of clouds, atmospheric aerosol/dust content, etc., as well as factors related with the hardware such as iris aperture, exposure time, contrast, colour gain, geometrical distortion and noise, introduce a great degree of complexity in automatic cloud monitoring. This complexity requires an approach in which the most essential features and corresponding multiple interactions might be modelled. We chose the neural networks approach since they are flexible, adaptive learning systems that find patterns in data of a nonlinear system.

The cloud cover detection algorithm in sky images starts by obtaining a sky image (Fig. 24.7A). Later the position of the shadow band is detected placing a similar mask over it (Fig. 24.7B), which is important to eliminate highlights and border effects in the image, and saves computer processing time since after masking there are less pixels. The algorithm analyses every single pixel and its 8-neighbourhood pixels of the image calculating their parameters (Fig. 24.7C). These parameters feed the trained neural network (Fig. 24.7D), and the neural network determines whether the pixel corresponds to cloud or clear sky. Finally, the algorithm generates an output image with detected cloudy pixels (Fig. 24.7E) and a percentage of cloudiness (González et al., 2012).

2013: Cloud nowcasting development

Here we present a summary of the results from González et al. (2013). The identification of cloudiness in nearby images in time allows us to improve the optical flow calculation between consecutive images using Farneback's algorithm. The goal of optical flow estimation is to compute an approximation to the motion field from time-varying image intensity. Some different time scales to calculate flow motion are needed due to the fact that apparent motion of high clouds is less than that of lower clouds. Once the optical flow has been calculated, it is necessary to cluster the whole motion field in the image into subfields which are formed by motion vectors with similar features. So, we can spot clouds with different relative motion. This relative motion might be due to the deformation of the image caused by the fisheye lens, or to the presence of different altitude cloud layers. Our algorithm groups motion vectors with similar direction and module, detecting the noise, which usually corresponds with some error vectors results of Farneback's algorithm. Every detected cluster gives an average vector. Using average vectors we can detect wind direction. The system saves the average vectors of some few consecutive previous images. This way, we obtain an accurate wind direction associated to clouds movement (Fig 24.8A). Taking into account the wind direction, the algorithm calculates the trajectories of every average motion vector and, therefore, the orbits of the clusters belonging to clouds. The trajectories are fitted to functions depending on the distance from the average vector to the zenith in the image (Fig. 24.8B).

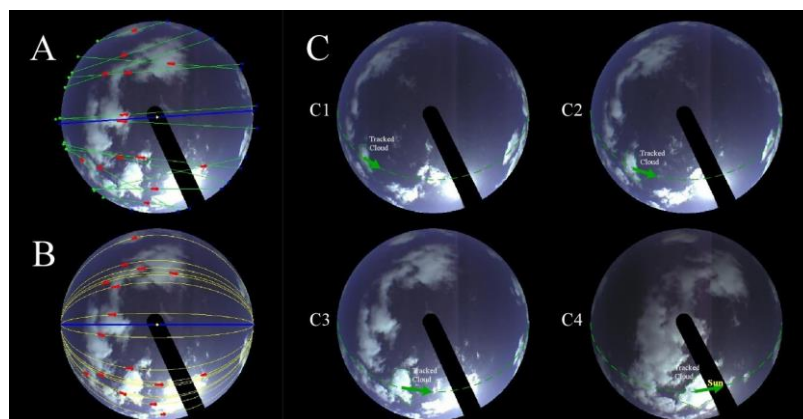

Figure 24.8. A) Calculation of wind direction (blue line) based on average cluster vectors. B) Trajectories corresponding to the cluster vectors. Every vector follows a calculated orbit function. C) Depending on future evolution of each vector in its own trajectory it is possible to estimate whether the sun will be blocked by clouds.

The future position of a cluster can be predicted if the trajectory function, and its corresponding average vector, is known. We can thus determine the future vector position in its orbit. This technique allows us to predict when the Sun will be blocked by clouds, which is quite interesting for solar energy applications (Fig. 24.8C). A good example of cloud tracking is shown in Figure 24.8. The selected cloud moved from position marked in C1 to position marked in C4 in only 195 seconds. This is the worst case, in which the Sun is very low over the horizon, the clouds are low and moving at high speed, so that the time between the detection of the cloud until it blocks the sun is very short. Previous works obtain a global vector for the behaviour of clouds scene, but they do not take into account the different cloud layers with different morphology, height and velocity vectors, nor the field distortion due to the fish eye optics.

2014: Testing and evaluation of new models of all-sky cameras

In 2014, after analyzing the technical features of the first version of SONA, SIELTEC CANARIAS concluded that they were sufficiently capable to develop a new range of all-sky cameras without shadow band by using the IARC Testbed. The new All-Sky camera models are based on lower dimensions, lighter, with a more robust design than the previous model, more accurate sensors and higher optical quality that allows better picture acquisitions from 16-bit raw files (Fig. 24.9). A new web based interface for cloud detection has been developed (Fig. 24.10).



Figure 24.9. New SONA201D.

Future activities

Image acquisition based on type of clouds, cloud type discrimination, estimation of upper wind from cloud movement, cloud height estimation through triangulation of two separate cameras, dust detection, etc. will be some of the future activities with All-Sky cameras. They will be developed in collaboration with other research groups with expertise on cloud detection and cloud microphysical properties. Synergies with solar energy industry constitute a pending initiative. Interaction and feedback between All-Sky cameras and other devices such as the Color Index Radiometer (see Section 17.3) will provide new insights, which will benefit both dust detection and solar irradiance nowcasting.

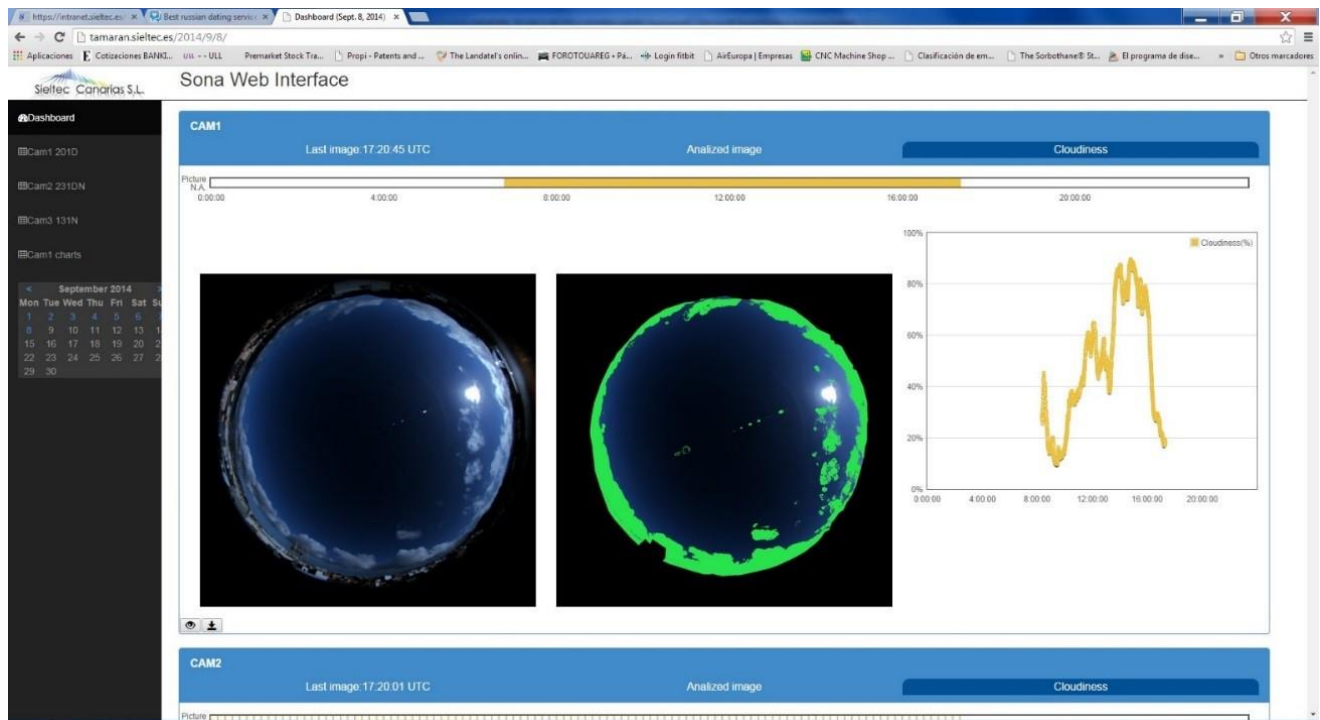

Figure 24.10. New web interface with cloud detection.

24.2.4 References

González, Y, C. López, and E. Cuevas, Automatic Observation of Cloudiness: Analysis of All-Sky Images, TECO-2012, WMO Technical Conference on Meteorological and Environmental Instruments and Methods of Observation, Session 3, Meeting the needs of climate observations, Brussels, Belgium, 16-18 October 2012.

González, Y., C. López, and E. Cuevas, Cloud Nowcasting: Motion Analysis of All-Sky Images using Velocity Fields, 19th IMEKO TC-4 Symposium, Measurements of Electrical Quantities Advances in Instrumentation and Sensors Interoperability, Barcelona, 18-19 July, 2013.

24.2.5 Staff

The SONA All-Sky Camera and Cloud Nowcasting research group is composed of the following researchers and specialist technicians from SIELTEC and IARC-AEMET:

Dr Yézer González Morales (SIELTEC)

César López Solano (SIELTEC)

Dr Emilio Cuevas (AEMET)

Ramón Ramos (AEMET)

24.3 SIELTEC Digital Sky Color Radiometer

Remote sensing of aerosols is an extended technique normally used to routinely monitor aerosol optical properties, such as AOD, by means of ground based and satellite measurements. The remote monitoring of atmospheric aerosols from space platforms introduces the advantage of excellent spatial coverage. However, the reduced temporal resolution of satellite-borne instruments and the need of periodical validations make it necessary to also deploy ground based instruments.

Currently there are extensive networks of ground based sun photometers all over the world for aerosols monitoring. The most important are AERONET (Holben et al., 1998); PFR-GAW (Wehrli, 2005); and SKYNET (Takamura and Nakajima, 2004). AERONET is the most widespread network and the data provided are currently used by a wide scientific community. It consists of over 1100 stations distributed across five continents, routinely and automatically providing information on aerosol optical and microphysical properties.

However, given the operational needs of the instruments commonly used in these type of global networks, their stations require an almost permanent support, so that they are deployed in locations near populated areas. In addition, the high cost of this type of instrument reduces its use to those countries or organizations with sufficient economic level to fund their purchase and maintenance. Consequently, there is a significant loss of information in unpopulated desert and low-income regions. An obvious example is the lack of measurement stations in the African continent which is the most important source region in the world of mineral dust and biomass burning aerosols.

The reasons mentioned above have motivated us to develop an instrument capable of supplying the deficiencies of spatial coverage in aerosol monitoring. This instrument is the SIELTEC Digital Sky Color Radiometer (SIELTEC-DSCR) device (Almansa et al., 2014; Fig. 24.11). It is a rather compact radiometer developed by the company SIELTEC Canarias SL in collaboration with the Izaña Atmospheric Research Center, which measures the scattered radiation in zenith direction. This instrument consists of five separate channels each one equipped with a Silicon detector (350-1100nm) and an optical filter of 10 nm FWHM, without moving parts and enclosed in a robust housing and an external window. It contains an internal datalogger of 16 bits resolution, 4 MB internal memory with Ethernet communications for data display and download, and settings of the instrument. Algorithms for products determination can be run inside its microcontroller board, which results in fast user-oriented data delivery (no additional parts or components are required) and a friendly-user interface.



Figure 24.11. Three SIELTEC-DSCR prototypes during calibration at IZO.

For cloud free conditions, the scattered radiation is produced by air molecules and aerosols, so it can be related to the AOD. This technique for AOD retrieval is not commonly used today; the measurement technique most frequently used is that of direct solar radiation measurements carried out by sun photometers. The measurement of direct solar radiation is a quite precise method to determine AOD and it is the best option for those places where a good calibration tracing and maintenance of instruments is performed by trained staff. However, if a high degree of autonomy and low maintenance is required, it is not a good choice. In this case, a more simple and robust device with no moving parts is more convenient. The SIELTEC-DSCR infers the AOD from the incoming zenith scattered radiation avoiding the needs of a sun tracker, with the only requirement of keeping its external window clean. In addition, its relatively simple design makes it a rather inexpensive instrument.

We have developed two methodologies that use the incoming scattered radiation from the zenith direction and take into account the solar zenith angle daily variation to obtain the AOD with the SIELTEC-DSCR device. These methodologies are not explained here as they will be published in an article in the near future.

Some SIELTEC-DSCR prototypes have been tested at IZO (Fig. 24.11) where we monitor aerosols under free troposphere conditions (very low AOD) and also have the opportunity to observe relatively strong Saharan dust

outbreaks (high AOD). We validate the AOD results through comparison with a collocated Cimel CE-318 AERONET sunphotometer installed at IZO and important ancillary information. The SIELTEC-DSCR has been tested at IZO for a long period covering different aerosol conditions (from AOD <0.01 to AOD >0.86). The scatter plot between the AOD obtained with the SIELTEC-DSCR device and the AOD from AERONET is shown in Fig. 24.12, where the red line represents the following linear fitting equation:

$$AOD_{DSCR} = 0.89 \times AOD_{AERO} + 0.01 \quad (\text{Equation 24.1})$$

The agreement between AOD from AERONET and AOD from SIELTEC-DSCR is quite good (Fig. 24.12) with a correlation coefficient of 0.97 and root mean square error of 0.04, although the AOD obtained with the SIELTEC-DSCR is generally 11% lower than that given by AERONET as can be seen from Eq. (24.1). This underestimation is not a problem for the instrument in terms of its accurate detection of atmospheric dust intrusions, for which purpose it has been designed.

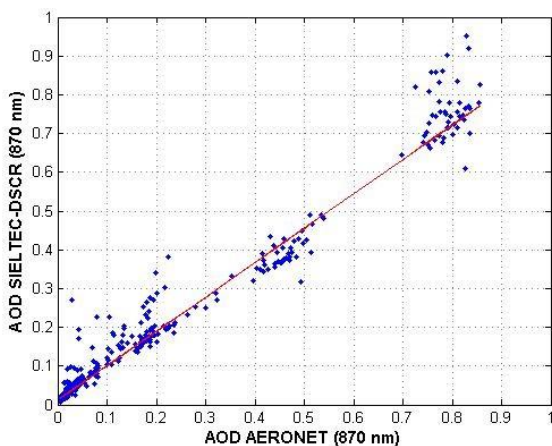

Figure 24.12. Scatter plot of AOD retrieved from AERONET in 870 nm versus the AOD in 870 nm retrieved with SIELTEC-DSCR. The fitting equation is also represented (red line).

The capabilities of the new SIELTEC-DSCR radiometer to estimate AOD are shown through systematic comparisons against AERONET Cimel sun-photometer under both clean conditions and moderate to strong Saharan dust outbreaks. In addition, the SIELTEC-DSCR has been intercompared with AERONET at sea level, within the Marine Boundary Layer where marine aerosols dominate, and this comparison has also shown good results.

We conclude that this low-cost device may be suitable for atmospheric dust monitoring in remote desert locations with little maintenance, allowing us to enhance the operational capability of global aerosol networks for dust monitoring, data assimilation and dust model and satellite validation nearby dust source regions. For example, this instrument could play a key role increasing the observational capacity

of the WMO Sand and Dust Storm Warning Advisory and Assessment System (SDS WAS).

24.3.1 References

- Almansa, F., E. Cuevas, C. López, A. Barreto, A. De Frutos, Aerosol optical depth inferred from zenith sky measurements using a new multifilter radiometer, Book of Abstracts, p 17, International Conference on ATMOSPHERIC DUST, Castellana Marina, Italy, June 1-6, 2014.
- Holben, B., Eck, T., Slutsker, I., Tanre, D., Buis, J., Setzer, A., Vermote, E., Reagan, J., Kaufman, Y., Nakajima, T., Lavenu, F., Jankowiak, I. and Smirnov, A. AERONET- A federated instrument network and data archive for aerosol characterization. REMOTE SENSING OF ENVIRONMENT, vol. 66(1), pages 1–16, 1998. ISSN 0034-4257.
- Takamura, T. and Nakajima, T. Overview of SKYNET and its activities. OPTICA PURA Y APLICADA, vol. 37, pages 3303–3308, 2004.
- Wehrli, C. GAW-PFR: A network of Aerosol Optical Depth observations with Precision Filter Radiometers. In: WMO/GAW Experts workshop on a global surface based network for long term observations of column aerosol optical properties. GAW Report No. 162, WMO TD No. 1287, 2005.

24.3.2 Staff

- Dr Emilio Cuevas (AEMET)
 Dr Ángel de Frutos (UVA/AEMET)
 Antonio Fernando Almansa (CIMEL/AEMET)
 Dr Africa Barreto (CIMEL/AEMET)
 Dr Rosa García (UVA/AEMET)
 César López Solano (SIELTEC)
 Ramón Ramos (AEMET)

25 Capacity Building Activities

During 2012-2014 IARC participated in various capacity building activities. For further details of these activities, see individual sections (e.g. Sections 17 to 22) or the [IARC webpage](#).

2012

Sun-photometry Training Course: Ouarzazate, Morocco, 9-12 Feb 2012

Ramón Ramos and Dr Alberto Berjón (IARC-AEMET) gave a Sun-photometry Training Course at Ouarzazate Met station, Morocco during 9-12 February 2012.



Second Training Course for Starlight Guides: Institute of Astrophysics of the Canary Islands, 25 Jun 2012

Rubén del Campo Hernández (IARC-AEMET) participated in the Second Training Course for Starlight Guides with a contribution on meteorology and cloud classification. This course was organized by the Institute of Astrophysics of the Canary Islands (IAC) on 25 June 2012.

Brewer Training for the Uruguay Antarctic Institute: Izaña, Spain, June-July 2012

There was a continuation of the collaboration with the Uruguay Antarctic Institute through the calibration of Brewer #155 and training of Brewer operator in Izaña in June-July 2012.

II Lectures on Atmospheric Mineral dust: Barcelona, Spain, 5-9 Nov 2012

Dr Emilio Cuevas and Dr Sergio Rodríguez (IARC-AEMET) participated in the Second Lectures on Atmospheric Mineral dust held in Barcelona, Spain, 5-9 November 2012.

Training Course on the Use of Satellite Products for Agrometeorological Applications: Niamey, Niger, 19-23 Nov 2012

Dr Emilio Cuevas (IARC-AEMET) participated in the Training Course on the Use of Satellite Products for Agrometeorological Applications held in Niamey, Niger, 19-23 November 2012.

Brewer Training course: Izaña, Spain, Dec 2012

A Brewer operation and data analysis training course for experts from the Korean Meteorological office was held at the Izaña Atmospheric Observatory, Tenerife during December 2012.

2013

Master of Environmental Engineering: Huelva, Spain, Jan 2013

Dr Sergio Rodríguez (IARC-AEMET) participated in the Master of Environmental Engineering at the Universidad Internacional de Andalucía with a lecture entitled: "Measurement of physicochemical properties of atmospheric aerosols".

Sun-photometry Training Course: Ouarzazate, Morocco, 17-21 Mar 2013

Ramón Ramos and Carmen Guirado Fuentes (IARC-AEMET) gave a Sun-photometry Training Course at Ouarzazate Met station, Morocco during 17-21 March 2013.



Technical Meeting on the Regional Programme to Combat Sand and Dust Storms (SDS), Abu Dhabi, United Arab Emirates, 6-7 May 2013

Dr Emilio Cuevas (IARC-AEMET) gave a presentation entitled: “Sand and Dust Storms Historical Trends and Pathways - Regional Assessment”, in the Technical Meeting on the Regional Programme to Combat Sand and Dust Storms (SDS), Abu Dhabi, United Arab Emirates, 6-7 May 2013.

Sun-photometry Training Course: Tunis-Carthage, Tunisia, 10-14 Jun 2013

Ramón Ramos and Dr Alberto Berjón (IARC-AEMET) gave a Sun-photometry Training Course at Tunis-Carthage, Tunisia, during 10-14 Jun 2013.

Sun-photometry Training Course: Izaña, Tenerife, 24-28 Jun 2013

Ms Zeinab Salah Mahmoud. Mr Ahmed AbdelHamid Ibrahim (Egyptian Meteorological Authority), Mr Faycal Elleuch and Mr Ahmed Hmam (Tunisia National Meteorological Office) attended a 32-hour training course on Cimel sun-photometer operation by Ms Carmen Guirado Fuentes, Mr Ramón Ramos, Dr Alberto Berjón, Dr Emilio Cuevas (IARC-AEMET), and Dr Yasmine Bennouna (UVA-GOA) during 18-20 November 2014.



Training Course on the Use of Satellite Products for Agrometeorological Applications: Accra, Ghana, 10-14 Jun 2013

Dr Emilio Cuevas (IARC-AEMET) participated in the Training Course on the Use of Satellite Products for Agrometeorological Applications held in Accra, Ghana, 10-14 June 2013.

GAW Sahara Brewer Training course: El Arenosillo, Spain, 10-21 Jun 2013

The GAW Sahara Brewer Training course funded by AECID and organized by the University of Extremadura, was held during the VIII RBCC-E campaign, 10-21 June 2013 at El Arenosillo, Spain.



Training Course “Observation and forecast of the chemical composition of the atmosphere”: Madrid, Spain, 7-10 Oct 2013

Dr Sergio Rodríguez (IARC-AEMET) participated in a training course entitled: “Observation and forecast of the chemical composition of the atmosphere” held in Madrid, Spain, 7-10 Oct 2013.

Workshop on Meteorology, Sand and Dust Storm, Combating Desertification and Erosion: Istanbul, Turkey, 28-31 Oct 2013

Dr Emilio Cuevas (IARC-AEMET) participated in the Workshop on Meteorology, Sand and Dust Storm, Combating Desertification and Erosion held in Istanbul, Turkey, 28-31 October 2013.

3rd Training Course on WMO SDS-WAS products: Muscat, Oman, 8-12 Dec 2013

Dr Emilio Cuevas (IARC-AEMET) participated in the 3rd Training Course on WMO SDS-WAS products (satellite and ground observation and modelling of atmospheric dust) held in Muscat, Oman, during 8-12 December 2013.

Sun-photometry Training Course: Algiers, Algeria, 10-12 Dec 2013

Ramón Ramos (IARC-AEMET) gave a Sun-photometry Training Course for staff at the Algerian Meteorological Office in Algiers, Algeria, 10-12 Dec 2013.

McIDAS tutorial with focus on atmospheric dust cases: Muscat, Oman, 15-16 Dec 2013

Dr Emilio Cuevas (IARC-AEMET) participated in a McIDAS tutorial with focus on atmospheric dust cases held in Muscat, Oman, during 15-16 Dec 2013.

CIAI collaboration with the University of La Laguna Undergraduate Internship Program: Nov-Dec 2013

IARC collaborated with the University of La Laguna, Tenerife, by offering external work experience in the framework of the Undergraduate Internship Programme for two physics students, during 18 November-13 December 2013. Daniel Ramos Hernández participated in the programme under the supervision of Dr Omaira García (IARC-AEMET) and Dr Fernando Lahoz (ULL) with the title: "Atmospheric gases intercomparison with Fourier transform infrared spectroscopy". Steven Milson participated in the programme under the supervision of Dr Emilio Cuevas (IARC-AEMET) and Dr Manuel Arbelo (ULL) with the title: "Preliminary analysis of atmospheric electric field data".

2014

Master of Environmental Engineering: Huelva, Spain, Jan 2014

Dr Sergio Rodríguez (IARC-AEMET) participated in the Master of Environmental Engineering at the Universidad Internacional de Andalucía with a lecture entitled: "Measurement of physicochemical properties of atmospheric aerosols".

EUBREWNET training school and Brewer Ozone Spectrophotometer open congress in conjunction with the 14th Biennial WMO-GAW Brewer Users Group Meeting: Tenerife, Spain, 24-28 Mar 2014

The event was a joint collaboration of EUBREWNET (COST Action ES1207) and WMO-GAW. The event was hosted by AEMET in Tenerife, 24-28 March 2014, with the collaboration of the Spanish Oceanographic Institute. The training school and congress were focused on operational, scientific and technical issues of the Brewer instrument (for more details, see Section 17.5.5).

Training Course on the Use of Satellite Products for Agrometeorological Applications: Ouagadougou, Burkina Faso, 5-9 May 2014

Dr Emilio Cuevas (IARC-AEMET) participated in the Training Course on the Use of Satellite Products for Agrometeorological Applications held in Ouagadougou, Burkina Faso, during 5-9 May 2014.

Sun-photometry Training Course: Izaña, Tenerife, 23-25 Sep 2014

Mr Souhail Krichen from the Tunisia National Meteorological Office (attended a 20-hour training course on Cimel sun-photometer operation given by Ms Carmen Guirado Fuentes and Dr Emilio Cuevas during 23-25 September 2014.



Training Course "Observation and forecast of air quality": La Antigua, Guatemala, 10-14 Nov 2014

Dr Sergio Rodríguez (IARC-AEMET) participated in the training course "Observation and forecast of air quality", organized by AEMET and AECID with a lecture entitled: "Aerosols and Reactive Gases". La Antigua Guatemala, 10-14 November 2014.

4th Training course on WMO SDS-WAS products: Casablanca, Morocco, 17-20 Nov 2014

Dr Emilio Cuevas and Dr Sergio Rodríguez (IARC-AEMET) participated in the 4th Training course on WMO SDS-WAS products (satellite and ground observation and modelling of atmospheric dust) held in Casablanca, Morocco, during 17-20 November 2014.

Sun-photometry Training Course: Izaña, Tenerife, 18-20 Nov 2014

Mr Abdelhamid Gouda Elawadi, Director of the Air Pollution Department - Egyptian Meteorological Authority attended a 20-hour training course on Cimel sun-photometer operation given by Ms Carmen Guirado Fuentes, under the supervision of Dr Emilio Cuevas, during 18-20 Nov 2014.



Invited Talk, Nautical, Naval Machines and Radio Electronics School (University of La Laguna): 21 Nov 2014

Rubén del Campo Hernández (IARC-AEMET) gave an invited talk entitled: "Introduction to Remote Sensing and Meteorological Prediction tools" at the Nautical, Naval Machines and Radio Electronics School (University of La Laguna), on November 21st, 2014.

CIAI collaboration with the University of La Laguna Undergraduate Internship Program: Nov-Dec 2014

IARC collaborated, for the second year, with the University of La Laguna, Tenerife, by offering external work experience in the framework of the Undergraduate Internship Program, during 17 November-13 December 2014. Oliver Díaz-Rodríguez participated in the programme under the supervision of Carmen Guirado Fuentes (IARC-AEMET) and Dr Manuel Arbelo-Pérez (ULL). The practical training focused on the calibration of two types of hand-held sun photometers: Calitoo and Microtops-II, for aerosol and ozone measurements, respectively.



Sun-photometry Training Course: Izaña, Tenerife, 2-4 Dec 2014

Mr Lahouari Zeudmi and Mr Mohamed Kharef from the Algerian Meteorological Office (Tamanrasset station) attended a 20-hour training course on Cimel sun-photometer operation given by Ms Carmen Guirado Fuentes and Mr Ramón Ramos, under the supervision of Dr Emilio Cuevas during 2-4 December 2014.



26 Publications

26.1 List of peer-reviewed papers

2014

- Andrey, J., E. Cuevas, M.C. Parrondo, S. Alonso-Pérez, A. Redondas, M. Gil-Ojeda.: Quantification of ozone reductions within the Saharan air layer through a 13-year climatologic analysis of ozone profiles, *Atmospheric Environment*, 84, 28-34, 2014.
- Barreto, A., Cuevas, E., Pallé, P., Romero, P. M., Guirado, C., Wehrli, C. J., and Almansa, F.: Recovering long-term aerosol optical depth series (1976–2012) from an astronomical potassium-based resonance scattering spectrometer, *Atmos. Meas. Tech.*, 7, 4103-4116, doi:10.5194/amt-7-4103-2014, 2014.
- Barthlott, S., Schneider, M., Hase, F., Wiegeler, A., Christner, E., González, Y., Blumenstock, T., Dohe, S., García, O. E., Sepúlveda, E., Strong, K., Mendonca, J., Weaver, D., Palm, M., Deutscher, N. M., Warneke, T., Notholt, J., Lejeune, B., Mahieu, E., Jones, N., Griffith, D. W. T., Velasco, V. A., Smale, D., Robinson, J., Kivi, R., Heikkinen, P., and Raffalski, U.: Using XCO₂ retrievals for assessing the long-term consistency of NDACC/FTIR data sets, *Atmos. Meas. Tech. Discuss.*, 7, 10513-10558, doi:10.5194/amtd-7-10513-2014, 2014.
- Bolsée, D., N. Pereira, W. Decuyper, D. Gillotay, H. Yu, P. Sperfeld, S. Pape, E. Cuevas, A. Redondas, Y. Hernández, M. Weber, Accurate Determination of the TOA Solar Spectral NIR Irradiance Using a Primary Standard Source and the Bouguer-Langley Technique Solar Physics, DOI: 10.1007/s11207-014-0474-1, 2014.
- Che, H., Xia, X., Zhu, J., Li, Z., Dubovik, O., Holben, B., Goloub, P., Chen, H., Estelles, V., Cuevas-Agulló, E., Blarel, L., Wang, H., Zhao, H., Zhang, X., Wang, Y., Sun, J., Tao, R., Zhang, X., and Shi, G.: Column aerosol optical properties and aerosol radiative forcing during a serious haze-fog month over North China Plain in 2013 based on ground-based sunphotometer measurements *Atmos. Chem. Phys.*, 14, 2125-2138, doi:10.5194/acp-14-2125-2014, 2014.
- Cuevas, E., Camino, C., Benedetti, A., Basart, S., Terradellas, E., Baldasano, J. M., Morcrette, J.-J., Marticorena, B., Goloub, P., Mortier, A., Berjón, A., Hernández, Y., Gil-Ojeda, M., and Schulz, M.: The MACC-II 2007–2008 reanalysis: atmospheric dust evaluation and characterization over Northern Africa and Middle East, *Atmos. Chem. Phys. Discuss.*, 14, 27797-27879, doi:10.5194/acpd-14-27797-2014, 2014.
- Diémoz, H., Siani, A. M., Redondas, A., Savastiouk, V., McElroy, C. T., Navarro-Comas, M., and Hase, F.: Improved retrieval of nitrogen dioxide (NO₂) column densities by means of MKIV Brewer spectrophotometers, *Atmos. Meas. Tech.*, 7, 4009-4022, doi:10.5194/amt-7-4009-2014, 2014.
- García, R. D., Cuevas, E., García, O. E., Cachorro, V. E., Pallé, P., Bustos, J. J., Romero-Campos, P. M., and de Frutos, A. M.: Reconstruction of global solar radiation time series from 1933 to 2013 at the Izaña Atmospheric Observatory, *Atmos. Meas. Tech.*, 7, 3139-3150, doi:10.5194/amt-7-3139-2014, 2014.
- García, R.D., O.E. García, E. Cuevas, V.E. Cachorro, P.M. Romero-Campos, R. Ramos and A.M. de Frutos, Solar radiation measurements compared to simulations at the BSRN Izaña station. Mineral dust radiative forcing and efficiency study, *JGR-Atmospheres*, Vol 119, 1-16, DOI: 10.1002/2013JD020301, 2014
- García, M. I., Rodríguez, S., González, Y., and García, R. D.: Climatology of new particle formation at Izaña mountain GAW observatory in the subtropical North Atlantic, *Atmos. Chem. Phys.*, 14, 3865-3881, doi:10.5194/acp-14-3865-2014, 2014.
- García, O.E., Schneider, M., Hase, F., Blumenstock, T., Sepúlveda, E., and González, Y.: Quality assessment of ozone total column amounts as monitored by ground-based solar absorption spectrometry in the near infrared (> 3000 cm⁻¹), *Atmos. Meas. Tech.*, 7, 3071-3084, doi:10.5194/amt-7-3071-2014, 2014.
- Gomez, L., Navarro-Comas, M., Puentedura, O., Gonzalez, Y., Cuevas, E., and Gil-Ojeda, M.: Long-path averaged mixing ratios of O₃ and NO₂ in the free troposphere from mountain MAX-DOAS, *Atmos. Meas. Tech.*, 7, 3373-3386, doi:10.5194/amt-7-3373-2014, 2014.
- Guirado, C., Cuevas, E., Cachorro, V. E., Toledano, C., Alonso-Pérez, S., Bustos, J. J., Basart, S., Romero, P. M., Camino, C., Mimouni, M., Zeudmi, L., Goloub, P., Baldasano, J. M., and de Frutos, A. M.: Aerosol characterization at the Saharan AERONET site Tamanrasset, *Atmos. Chem. Phys.*, 14, 11753-11773, doi:10.5194/acp-14-11753-2014, 2014.
- Karppinen, T, A. Redondas, R.D. García, K. Lakkala, C.T. McElroy & E. Kyrö, Compensating for the Effects of Stray Light in Single-Monochromator Brewer Spectrophotometer Ozone Retrieval, *Atmosphere-Ocean*, DOI: 10.1080/07055900.2013.871499, 2014.
- Méndez-Ramos, J., P. Acosta-Mora, J.C. Ruiz-Morales, M. Sierra, A. Redondas, E. Ruggiero, L. Salassa, M.E. Borges and P. Esparza; Rare-earth doped colour tuneable up-conversion ZBLAN phosphor for enhancing photocatalysis, *Optical Materials*, November 2014
- Pérez García-Pando, C., M.C. Stanton, P.J. Diggle, S. Trzaska, R.L. Miller, J.P. Perlwitz, J.M. Baldasano, E. Cuevas, P. Ceccato, P. Yaka, and M.C. Thomson, 2014, Soil Dust Aerosols and Wind as Predictors of Seasonal Meningitis Incidence in Niger, *Environmental Health Perspectives* doi:10.1289/ehp.1306640.
- Redondas, A., Evans, R., Stuebi, R., Köhler, U., and Weber, M.: Evaluation of the use of five laboratory-determined ozone absorption cross sections in Brewer and Dobson retrieval algorithms, *Atmos. Chem. Phys.*, 14, 1635-1648, doi:10.5194/acp-14-1635-2014, 2014.
- Rodríguez, S., Cuevas, E., Prospero, J. M., Alastuey, A., Querol, X., López-Solano, J., García, M. I., and Alonso-Pérez, S.: Modulation of Saharan dust export by the North African dipole, *Atmos. Chem. Phys. Discuss.*, 14, 26689-26719, doi:10.5194/acpd-14-26689-2014, 2014.
- Salvador, P., Alonso-Pérez, S., Pey, J., Artíñano, B., de Bustos, J. J., Alastuey, A. and Querol, X.: African dust outbreaks over the western Mediterranean Basin: 11-year characterization of atmospheric circulation patterns and dust source areas, *Atmos. Chem. Phys.*, 14, 6759–6775, 2014, doi:10.5194/acp-14-6759-2014.
- Scheepmaker, R. A., Frankenberg, C., Deutscher, N. M., Schneider, M., Barthlott, S., Blumenstock, T., Garcia, O. E., Hase, F., Jones, N., Mahieu, E., Notholt, J., Velasco, V., Landgraf, J., and Aben, I.: Validation of SCIAMACHY HDO/H₂O measurements using the TCCON and NDACC-MUSICA networks, *Atmos. Meas. Tech. Discuss.*, 7, 11799-11851, doi:10.5194/amtd-7-11799-2014, 2014.

- Schneider, M., González, Y., Dyroff, C., Christner, E., Wiegeler, A., Barthlott, S., García, O. E., Sepúlveda, E., Hase, F., Andrey, J., Blumenstock, T., Guirado, C., Ramos, R., and Rodríguez, S.: Empirical validation and proof of added value of MUSICA's tropospheric δD remote sensing products, *Atmos. Meas. Tech. Discuss.*, 7, 6917-6969, doi:10.5194/amtd-7-6917-2014, 2014.
- Sepúlveda, E., Schneider, M., Hase, F., Barthlott, S., Dubravica, D., García, O. E., Gomez-Pelaez, A., González, Y., Guerra, J. C., Gisi, M., Kohlhepp, R., Dohe, S., Blumenstock, T., Strong, K., Weaver, D., Palm, M., Sadeghi, A., Deutscher, N. M., Warneke, T., Notholt, J., Jones, N., Griffith, D. W. T., Smale, D., Brailsford, G. W., Robinson, J., Meinhardt, F., Steinbacher, M., Aalto, T., and Worthy, D.: Tropospheric CH₄ signals as observed by NDACC FTIR at globally distributed sites and comparison to GAW surface in-situ measurements, *Atmos. Meas. Tech.*, 7, 2337-2360, doi:10.5194/amt-7-2337-2014, 2014.
- Torres, B., Dubovik, O., Toledano, C., Berjon, A., Cachorro, V. E., Lapyonok, T., Litvinov, P., and Goloub, P.: Sensitivity of aerosol retrieval to geometrical configuration of ground-based sun/sky radiometer observations, *Atmos. Chem. Phys.*, 14, 847-875, doi:10.5194/acp-14-847-2014, 2014.
- Vigouroux, C., Blumenstock, T., Coffey, M., Errera, Q., García, O., Jones, N. B., Hannigan, J. W., Hase, F., Liley, B., Mahieu, E., Mellqvist, J., Notholt, J., Palm, M., Persson, G., Schneider, M., Servais, C., Smale, D., Thölix, L., and De Mazière, M.: Trends of ozone total columns and vertical distribution from FTIR observations at 8 NDACC stations around the globe, *Atmos. Chem. Phys. Discuss.*, 14, 24623-24666, doi:10.5194/acpd-14-24623-2014, 2014.
- Wiegeler, A., Schneider, M., Hase, F., Barthlott, S., García, O. E., Sepúlveda, E., González, Y., Blumenstock, T., Raffalski, U., Gisi, M., and Kohlhepp, R.: The MUSICA MetOp/IASI H₂O and δD products: characterisation and long-term comparison to NDACC/FTIR data, *Atmos. Meas. Tech.*, 7, 2719-2732, doi:10.5194/amt-7-2719-2014, 2014.
- Zhuang, X., Wang, Y., Zhu, Z., Querol, X., Alastuey, A., Rodríguez, S., Wei, H., Xu, S., Lu, W., Viana, M., Minguillón, M. C.: Origin of PM₁₀ Pollution Episodes in an Industrialized Mega-City in Central China, *Aerosol Air Qual. Res.*, 14, 338-346, doi: 10.4209/aaqr.2012.11.0316, 2014.
- ## 2013
- Barreto, A., Cuevas, E., Damiri, B., Romero, P. M., and Almansa, F.: Column water vapor determination in night period with a lunar photometer prototype, *Atmos. Meas. Tech.*, 6, 2159-2167, doi:10.5194/amt-6-2159-2013, 2013.
- Barreto, A., Cuevas, E., Damiri, B., Guirado, C., Berkoff, T., Berjón, A. J., Hernández, Y., Almansa, F., and Gil, M.: A new method for nocturnal aerosol measurements with a lunar photometer prototype, *Atmos. Meas. Tech.*, 6, 585-598, doi:10.5194/amt-6-585-2013, 2013.
- Che, H., Xia, X., Zhu, J., Li, Z., Dubovik, O., Holben, B., Goloub, P., Chen, H., Estelles, V., Cuevas-Agulló, E., Blarel, L., Wang, H., Zhao, H., Zhang, X., Wang, Y., Sun, J., Tao, R., Zhang, X., and Shi, G.: Column aerosol optical properties and aerosol radiative forcing during a serious haze-fog month over North China Plain in 2013 based on ground-based sunphotometer measurements, *Atmos. Chem. Phys. Discuss.*, 13, 29685-29720, doi:10.5194/acpd-13-29685-2013, 2013.
- Cuevas, E., González, Y., Rodríguez, S., Guerra, J. C., Gómez-Peláez, A. J., Alonso-Pérez, S., Bustos, J., and Milford, C.: Assessment of atmospheric processes driving ozone variations in the subtropical North Atlantic free troposphere, *Atmos. Chem. Phys.*, 13, 1973-1998, doi:10.5194/acp-13-1973-2013, 2013.
- Dohe, S., F. Hase, E. Sepúlveda, A. Gomez-Pelaez, M. Schneider, T. Blumenstock, and O. García, CO₂ total column amounts at TCCON sites Izaña (28.3 N, 16.5 W) and Karlsruhe (49.1 N, 8.5 E), AIP Conference Proceedings, 1531, 304-307, doi:10.1063/1.4804767, 2013.
- Dohe, S.; V. Sherlock; F. Hase; M. Gisi; J. Robinson; E. Sepúlveda, M. Schneider; T. Blumenstock.: A method to correct sampling ghosts in historic near-infrared Fourier Transform Spectrometer (FTS) measurements. *Atmos. Meas. Tech.*, 6, 1981-1992, 2013.
- Domínguez-Rodríguez, A., Abreu-Afonso, J., González, Y., Rodríguez, S., Juárez-Prera, R. A., E., Jiménez-Sosa, A., Abreu-González, P., Avanzas, P., Relationship between short-term exposure to atmospheric sulfur dioxide and obstructive lesions in acute coronary syndrome, *Med. Clín.*, 140(12): 537-541, 2013.
- Dominguez-Rodriguez, A., Abreu-Afonso, J., Rodríguez, S., Juárez-Prera, R. A., Arroyo-Ucar, E., González, Y., Abreu-González, P., Avanzas, P., Air pollution and heart failure: Relationship with the ejection fraction, *World Journal of Cardiology*, 26; 5(3): 49-53, 2013.
- Domínguez-Rodríguez, A., S. Rodríguez, P. Abreu, R. Juárez, P. Avanzas. Impact of air pollution on inflammation, oxidative stress and 1-year prognosis in patients hospitalized for acute coronary syndrome: design of the AIRACOS study, *Med. Clin. (Barc)*, 141(12):529-32. doi: 10.1016/j.medcli.2013.05.024, 2013.
- García, M. I., Rodríguez, S., González, Y., and García, R. D.: Climatology of new particle formation events in the subtropical North Atlantic free troposphere at Izaña GAW observatory, *Atmos. Chem. Phys. Discuss.*, 13, 24127-24169, doi:10.5194/acpd-13-24127-2013, 2013.
- García, O.E., M. Schneider, F. Hase, T. Blumenstock, E. Sepúlveda and A. Gómez-Peláez, Validation of the IASI operational CH₄ and N₂O products using ground-based Fourier Transform Spectrometer: Preliminary results at the Izaña Observatory (28°N, 17°W), *Annals of Geophysics, Fast Track-1*, 10.4401/ag-6326, 2013.
- Gomez, L., Navarro-Comas, M., Puentedura, O., Gonzalez, Y., Cuevas, E., and Gil-Ojeda, M.: Long-path averaged mixing ratios of O₃ and NO₂ in the free troposphere from mountain MAX-DOAS, *Atmos. Meas. Tech. Discuss.*, 6, 8235-8267, doi:10.5194/amtd-6-8235-2013, 2013.
- Gomez-Pelaez, A. J., Ramos, R., Gomez-Trueba, V., Novelli, P. C., and Campo-Hernandez, R.: A statistical approach to quantify uncertainty in carbon monoxide measurements at the Izaña global GAW station: 2008-2011, *Atmos. Meas. Tech.*, 6, 787-799, doi:10.5194/amt-6-787-2013, 2013.
- González, Y. and Rodríguez, S.: A comparative study on the ultrafine particle episodes induced by vehicle exhaust, a crude oil refinery and ship emissions, *Atmospheric Research* 120-121, 43-54, 2013.
- Milford, C., Castell, N., Marrero, C., Rodríguez, S., Sánchez de la Campa, A.M., Fernández-Camacho, R., de la Rosa J. and Stein, A.F. Measurements and simulation of speciated PM_{2.5} in south-west Europe, *Atmospheric Environment*, 77, 36-50, 2013.
- Oltmans, S., Lefohn, A., Shadwick, D., Harris, J., Scheel, H. Galbally, I., Tarasick, D., Johnson, B., Brunke, E., Claude, H., Zeng, G., Nichol, S., Schmidlin, F., Davies, J., Cuevas, E., Redondas, A., Naoe, H., Nakano, T., and Kawasato, T.: Recent

- tropospheric ozone changes - A pattern dominated by slow or no growth, *Atmos. Environ.*, 67, 331-351, 2013.
- Ortiz de Galisteo, J. P., Bennouna, Y., Toledano, C., Cachorro, V., Romero, P., Andrés, M. I. and Torres, B. (2013): Analysis of the annual cycle of the precipitable water vapour over Spain from 10-year homogenized series of GPS data, *Q.J.R. Meteorol. Soc.* doi: 10.1002/qj.2146.
- Querol, X., A. Alastuey, M. Viana, T. Moreno, C. Reche, M. C. Minguillón, A. Ripoll, M. Pandolfi, F. Amato, A. Karanasiou, N. Pérez, J. Pey, M. Cusack, R. Vázquez, F. Plana, M. Dall'Osto, J. de la Rosa, A. Sánchez de la Campa, R. Fernández-Camacho, S. Rodríguez, C. Pio, L. Alados-Arboledas, G. Titos, B. Artíñano, P. Salvador, S. García Dos Santos, and R. Fernández Patier, Variability of carbonaceous aerosols in remote, rural, urban and industrial environments in Spain: implications for air quality policy, *Atmos. Chem. Phys.*, 13, 6185–6206, 2013.
- Redondas, A., Evans, R., Stuebi, R., Köhler, U., and Weber, M.: Evaluation of the use of five laboratory-determined ozone absorption cross sections in Brewer and Dobson retrieval algorithms, *Atmos. Chem. Phys. Discuss.*, 13, 22979-23021, doi:10.5194/acpd-13-22979-2013, 2013.
- Rodriguez-Franco, J. J., and Cuevas, E. (2013), Characteristics of the subtropical tropopause region based on long-term highly-resolved sonde records over Tenerife, *J. Geophys. Res. Atmos.*, 118, doi:10.1002/jgrd.50839.
- Sutton, M. A., Reis, S., Riddick, S. N., Dragosits, U., Nemitz, E., Theobald, M. R., Tang, Y. S., Braban, C. F., Viena, M., Dore, A. J., Mitchell, R. F., Wanless, S., Daunt, F., Fowler, D., Blackall, T. D., Milford, C., Flechard, C. R., Loubet, B., Massad, R., Cellier, P., Personne, E., Coheur, P. F., Clarisse, L., Van Damme, M., Ngadi, Y., Clerbaux, C., Skjøth, C. A., Geels, C., Hertel, O., Wichink Kruit, R. J., Pinder, R. W., Bash, J. O., Walter, J. T., Simpson, D., Horváth, L., Misselbrook, T. H., Bleeker, A., Dentener, F. and de Vries, W.: Towards a climate-dependent paradigm of ammonia emission and deposition, *Philosophical Transactions of the Royal Society B.*, 368 20130166; doi:10.1098/rstb.2013.0166, 2013.
- Zhuang, X., Wang, Y., Zhu, Z., Querol, X., Alastuey, A., Rodríguez, S., H. Wei, S. Xu, W. Lu, M.C. Minguillón, M. Viana. Origin of PM10 pollution episodes in an industrialized megacity in Central China. *Aerosol and Air Quality Research* in press.
- 2012**
- Alonso-Pérez, S., Cuevas E., Querol X., Guerra J. C., Pérez C.: African dust source regions for observed dust outbreaks over the Subtropical Eastern North Atlantic region, above 25°N. *Journal of Arid Environments*, 78, 100-109, 2012. doi: 10.1016/j.jaridenv.2011.11.013
- Basart, S., Pérez, C., Nickovic, S., Cuevas, E., & Baldasano, J., Development and evaluation of the BSC-DREAM8b dust regional model over Northern Africa, the Mediterranean and the Middle East. *Tellus B*, 64. doi: http://dx.doi.org/10.3402/tellusb.v64i0.18539, 2012
- Dall'Osto, M., D.C.S. Beddows, J. Pey, S. Rodriguez, A. Alastuey, R. M. Harrison, and X. Querol, Urban aerosol size distributions over the Mediterranean city of Barcelona, NE Spain, *Atmos. Chem. Phys.*, 12, 10693-10707, 2012, doi:10.5194/acp-12-10693-2012.
- Fernández-Camacho, R., S. Rodríguez, J. de la Rosa, A.M. Sánchez de la Campa, A. Alastuey, X. Querol, Y. González-Castanedo, I. García-Orellana, S. Nava, Ultrafine particle and trace trace metal (As, Cd, Cu, Pb and Zn) pollution episodes induced by industrial emissions in Huelva, SW Spain, *Atmos. Environ.*, 61, 507-517, 2012.
- García, R.D., V.E. Cachorro, E. Cuevas, A. Redondas, A.M. de Frutos, A. Berjón, Comparison of measured and modeled UV spectral irradiance at the Izaña station based on LibRadtran and UVA-GOA models, *Opt. Pura Apl.*, 45 (1) 11-15, Special Section: 37th AMASOM Instrumentation and Techniques, 2012.
- García, O. E., Díaz, J. P., Expósito, F. J., Díaz, A. M., Dubovik, O., Derimian, Y., Dubuisson, P., and Roger, J.-C.: Shortwave radiative forcing and efficiency of key aerosol types using AERONET data, *Atmos. Chem. Phys.*, 12, 5129-5145, doi:10.5194/acp-12-5129-2012, 2012.
- García, R.D., R. Ramos, E. Cuevas, V.E. Cachorro, A.M. de Frutos, The Izaña BSRN Station, *Opt. Pura Apl.*, 45 (1) 51-55, Special Section: 37th AMASOM Instrumentation and Techniques, 2012.
- García, O. E., Schneider, M., Redondas, A., González, Y., Hase, F., Blumenstock, T., and Sepúlveda, E.: Investigating the long-term evolution of subtropical ozone profiles applying ground-based FTIR spectrometry, *Atmos. Meas. Tech.*, 5, 2917-2931, doi:10.5194/amt-5-2917-2012, 2012.
- Guirado, C., R. Ramos, A. de Frutos, A. Berjón, A. Redondas, C. López, V. Cachorro, E. Cuevas, R. González, S. González, M. Hernández, Optical calibration facility at the Izaña Atmospheric Research Center, *Opt. Pura Apl.*, 45 (1) 57-62, Special Section: 37th AMASOM Instrumentation and Techniques, 2012.
- Kerzenmacher, T., Dils, B., Kumps, N., Blumenstock, T., Clerbaux, C., Coheur, P.-F., Demoulin, P., García, O., George, M., Griffith, D. W. T., Hase, F., Hadji-Lazarou, J., Hurtmans, D., Jones, N., Mahieu, E., Notholt, J., Paton-Walsh, C., Raffalski, U., Ridder, T., Schneider, M., Servais, C., and De Mazière, M.: Validation of IASI FORLI carbon monoxide retrievals using FTIR data from NDACC, *Atmos. Meas. Tech.*, 5, 2751-2761, doi:10.5194/amt-5-2751-2012, 2012.
- López-Pérez, M., R. Ramos-López, Nayra R. Perestelo, X. Duarte-Rodriguez, J.J. Bustos, S. Alonso-Pérez, E. Cuevas, J. Hernández-Armas.: Arrival of radionuclides released by the Fukushima accident to Tenerife (Canary Islands). *Journal of Environmental Radioactivity*, 116 (2013), pp. 180-186. doi: 10.1016/j.jenvrad.2012.09.011
- Martín, J.L., Bethencourt, J. and Cuevas-Agulló, E., Assessment of global warming on the island of Tenerife, Canary Islands (Spain). Trends in minimum, maximum and mean temperatures since 1944, *Climatic Change*, DOI 10.1007/s10584-012-0407-7, 2012.
- Mazzola, M., A. Lupi, V. Vitale, C. Tomasi, R. S. Stone, A. Herber, C. Toledano, V. E. Cachorro, B. Torres, A. Berjón, J. P. Ortiz, N. T. O. Neill, S. Masataka, K. Stebel, V. Aaltonen, T. Zielinski, T. Petelski, P. Goloub, L. Blarel, Z. Li, I. Abboud, E. Cuevas, M. Stock, K-H. Schulz, A. Virkkula, Evaluation of Sun photometer capabilities for retrievals of aerosol optical depth at high latitudes: the POLAR-AOD intercomparison campaigns, *Atmos. Environ.*, 52, 4-17, (2012).
- Puentedura, O., Gil, M., Saiz-Lopez, A., Hay, T., Navarro-Comas, M., Gómez-Pelaez, A., Cuevas, E., Iglesias, J., and Gomez, L.: Iodine monoxide in the north subtropical free troposphere, *Atmos. Chem. Phys.*, 12, 4909-4921, doi:10.5194/acp-12-4909-2012, 2012.
- Risi, C., Noone, D., Worden, J. Frankenberg, C., Stiller, G., Kiefer, M., Funke, B., Walker, K., Bernath, P., Schneider, M., Wunch,

- D., Sherlock, V., Deutscher, N., Griffith, D., Wennberg, P.O., Strong, K., Smale, D., Mahieu, E., Barthlott, S. Hase, F., García, O., Notholt, J., Warneke, T., Toon, G., Sayres, D., Bony, S., Lee, J., Brown, D., Uemura, R., y Sturm, C.: Process-evaluation of tropospheric humidity simulated by general circulation models using water vapor isotopologues: 1. Comparison between models and observations, *J. Geophys. Res.*, 117, D05303, doi:10.1029/2011JD016621, 2012.
- Risi, C., Noone, D., Worden, J. Frankenberg, C., Stiller, G., Kiefer, M., Funke, B., Walker, K., Bernath, P., Schneider, M., Bony, S., Lee, J., Brown, D. and Sturm, C.: Process-evaluation of tropospheric humidity simulated by general circulation models using water vapor isotopic observations: 2. Using isotopic diagnostics to understand the mid and upper tropospheric moist bias in the tropics and subtropics, *J. Geophys. Res.*, 117, D05304, doi:10.1029/2011JD016623.
- Rodríguez, S., A. Alastuey, X. Querol, A review of methods for long term in situ characterization of aerosol dust, *J. Aeolian Research* 6, 55-74, 2012.
- Schneider, M., Barthlott, S., Hase, F., González, Y., Yoshimura, K., García, O. E., Sepúlveda, E., Gomez-Pelaez, A., Gisi, M., Kohlhepp, R., Dohe, S., Blumenstock, T., Wiegeler, A., Christner, E., Strong, K., Weaver, D., Palm, M., Deutscher, N. M., Warneke, T., Notholt, J., Lejeune, B., Demoulin, P., Jones, N., Griffith, D. W. T., Smale, D., and Robinson, J.: Ground-based remote sensing of tropospheric water vapour isotopologues within the project MUSICA, *Atmos. Meas. Tech.*, 5, 3007-3027, doi:10.5194/amt-5-3007-2012, 2012.
- Schulz, M., J.M. Prospero, A.R. Baker, F. Dentener, L. Ickes, P.S. Liss, N.M. Mahowald, S. Nickovic, C. PérezGarcía-Pando, S. Rodríguez, M. Sarin, I. Tegen, and R. A. Duce: Atmospheric Transport and Deposition of Mineral Dust to the Ocean: Implications for Research Needs, *Environ. Sci. Technol.*, 46, 10390-10404, 2012.
- Sepúlveda, E., M. Schneider; F. Hase; O. E. García; A. Gómez Pelaez; S. Dohe; T. Blumenstock; J. C. Guerra.: Long-term validation of tropospheric column-averaged CH₄ mole fractions obtained by mid-infrared ground-based FTIR spectrometry, *Atmos. Meas. Tech.*, 5, 1425-1441, 2012.
- Sepúlveda, E., M. Schneider, A. Gómez, E. Cuevas, F. Hase, T. Blumenstock, J.C. Guerra, Total Carbon Column Observing Network (TCCON) activities at Izaña, Tenerife, *Opt. Pura Apl.*, 45 (1) 1-4, Special Section: 37th AMASOM Instrumentation and Techniques, 2012.
- Barthlott, S., et al., Quality assessment of MUSICA/FTIR datasets, NDACC-IRWG/TCCON meeting 2014, 12-16 May, Bad Sulza (Germany), 2014.
- Carreño, V., Redondas, A. and Diemoz, H., "Brewer Model", COST 1207 European Brewer Network. Netherlands, Delft, 11th, November, 2014.
- Carreño, V., Redondas, A., Rodríguez-Franco J.J. and Sierra, M., "RBCC-E Triad status update" COST ACTION ES1207 EUBREWNET OPEN CONGRESS /14th WMO-GAW BREWER USERS GROUP MEETING EUBREWNET & WMO GAW, Tenerife, 24-28 March 2014.
- Córdoba-Jabonero, C., Andrey, J., Gómez L., Parrondo, M.C., Adame, J.A., Puentedura, O., Cuevas, E., Gil-Ojeda, M. Saharan dust profiling during AMISOC 2013 campaign: Optical and microphysical properties derived from multi-platform in-situ and remote sensing techniques. 2nd Iberian Meeting on Aerosol Science and Technology, 7-9 July, Tarragona (Spain), 2014.
- Córdoba-Jabonero, C., Larroza, E. G., Landulfo, E., Nakaema, W. M., Cuevas, E., Ochoa, H., Gil-Ojeda, M. Cirrus clouds profiling at subtropical and polar latitudes: Optical / macrophysical properties derived from active remote sensing observations. 2nd Iberian Meeting on Aerosol Science and Technology, 7-9 July, Tarragona (Spain), 2014.
- Córdoba-Jabonero, C., J. Andrey, L. Gómez, M.C. Parrondo, J. A. Adame, O. Puentedura, E. Cuevas, M. Gil-Ojeda, Multi-platform in-situ and remote sensing techniques to derive Saharan dust properties during AMISOC-TNF 2013, *Proc. SPIE* 9242, Amsterdam, 24-25 September, 2014, Remote Sensing of Clouds and the Atmosphere XIX; and Optics in Atmospheric Propagation and Adaptive Systems XVII, 924209 doi: 10.1117/12.2067173, 17 October 2014.
- Córdoba-Jabonero, C., E. Larroza, E. Landulfo, W. M. Nakaema, E. Cuevas, H. Ochoa, M. Gil-Ojeda, Active remote sensing observations for Cirrus Clouds profiling at subtropical and polar latitudes, *Proc. SPIE* 9242, Amsterdam, 24-25 September, 2014, Remote Sensing of Clouds and the Atmosphere XIX; and Optics in Atmospheric Propagation and Adaptive Systems XVII, 924209 doi: 10.1117/12.2067173, 17 October 2014.
- Cruz, B. H. Comparative Study between Brewer Spectrophotometer Networks COST 1207 European Brewer Network, Delft, 11-12 November 2014
- Cruz, B. H. Neubrew: Short Term Scientific Mission, Boulder, CO, COST 1207 European Brewer Network, Arosa, 23-24 July 2014
- Cuevas, E., S. Basart, J.M. Baldasano, C. Camino, E. Terradellas, A. Benedetti, J.-J. Morcrette, P. Goloub, A. Mortier, A. Berjón, Y. García, M. Gil, The MACC-II 2007-2008 Reanalysis: Atmospheric Dust Validation and Characterization over Northern Africa and Middle East, MACC-II Open Science Conference, Brussels, 27 - 30 January 2014.
- Cuevas, E., García, R.D., Ramos, R., Cachorro, V.E., and de Frutos, A.M. Status of the Izaña BSRN Station. 13th BSRN Scientific Review and Workshop Bologna (Italy) September 9-12, 2014
- Cuevas, E., and J. González-Breña, WMO-CIMO Testbed for Aerosols and Water Vapor Remote Sensing Instruments (Izaña, Spain) Proposal, CIMO-16, St.-Petersburg, Russian Federation, 10 - 16 July 2014.
- Cuevas, E., A. Gómez-Peláez, A. Redondas, O. García, S. Rodríguez, R. Ramos, P.M. Romero-Campos, R.D. García, Y. González, A. Berjón, C. Guirado, J.J. Rodríguez, A. Barreto, F.

26.2 Conference Presentations/Posters

2014

- Almansa, F., E. Cuevas, C. López, A. Barreto, A. De Frutos, Aerosol optical depth inferred from zenith sky measurements using a new multifilter radiometer, *Book of Abstracts*, p 17, International Conference on ATMOSPHERIC DUST, Castellana Marina, Italy, June 1-6, 2014.
- Barreto, A., E. Cuevas, A. Mortier, P. Goloub, T. Podvin, L. Blarel, V. Choliy, and Y. Hernández, Nighttime characterization of AOD and water vapor using lunar photometry. Synergies with Lidar technique, WMO-TECO/CIMO-16, Commission for Instruments and Methods of Observations (CIMO), St. Petersburg, Russian Federation, July 7-9, 2014.
- Barreto, A., E. Cuevas, M. Canini, B. Damiri, A. Almansa, and F. Maupin, Lunar Calibration, AERONET Workshop, Valladolid, October 14-17, 2014.

- Almansa, J.J. Bustos, Activities of the Izaña Atmospheric Research Center within the Global Atmosphere Watch (GAW), XXXIII Jornadas Científicas de la AME, Tiempo Clima y Sociedad, Oviedo, Spain, April 7-9, 2014.
- Cuevas, E., E. Terradellas, J.M. Baldasano, S. Nickovic, WMO Sand and Dust Storm Warning Advisory and Assessment System: Regional Center for Northern Africa, Middle East and Europe, DUST2014, 1st International Conference on Atmospheric Dust, Castellaneta Marina, Italy, June 16, 2014.
- Dohe, S., F. Hase, E. Sepúlveda, O.E. García, D. Wunch, P. Wennberg, A. Gómez-Peláez, J.B. Abshire, S.C. Wofsy, M. Schneider, T. Blumenstock; CO₂ profile retrievals from TCCON spectra, Geophysical Research Abstracts, 16, EGU2014-14952-1, 2014
- Dohe, S., F. Hase, E. Sepúlveda, O.E. García, D. Wunch, P. Wennberg, A. Gómez-Peláez, J.B. Abshire, S.C. Wofsy, M. Schneider, and T. Blumenstock: CO₂ profile retrievals from TCCON spectra, NDACC-IRWG/TCCON meeting 2014, 12-16 May, Bad Sulza (Germany), 2014.
- Fernández-Camacho, R., Rodríguez, S., de la Rosa, J.D. Sources of ultrafine and black carbon particles in Seville urban city. 2nd Iberian Meeting on Aerosol Science and Technology, 7-9 July, Tarragona (Spain), 2014.
- García, R.D., García O.E., Cachorro, V.E., Cuevas, E., Guirado, C., Hernández, Y., Berjón, A., and de Frutos, A.M. Vertical distribution of the mineral dust radiative forcing in Tenerife. 2nd Iberian Meeting on Aerosol Science and Technology, 7-9 July, Tarragona (Spain), 2014.
- García, R.D., García, O.E., Cuevas, E., Cachorro, V.E., and de Frutos, A.M. Long-Term in global solar radiation at the Izaña Atmospheric Observatory from 1933-2013. 13th BSRN Scientific Review and Workshop Bologna (Italy) September 9-12, 2014
- García, O.E., M. Schneider, F. Hase, T. Blumenstock, E. Sepúlveda, E. Cuevas, A. Redondas, A. Gómez-Peláez and J.J. Bustos, Effect of updates in LINEFIT and PROFFIT at Izaña ground-based FTIR: improvement of the ILS characterisation and intra-day pressure and temperature variability, NDACC-IRWG/TCCON meeting 2014, 12-16 May, Bad Sulza (Germany), 2014.
- García, O.E., M. Schneider, F. Hase, T. Blumenstock, E. Sepúlveda, A. Gómez-Peláez, S. Barthlott, S. Dohe, Y. González, F. Meinhardt and M. Steinbacher, Monitoring of N₂O by ground-based FTIR: optimisation of retrieval strategies and comparison to GAW insitu observations IRWG, NDACC-IRWG/TCCON meeting 2014, 12-16 May, Bad Sulza (Germany), 2014.
- García, O.E., E. Sepúlveda, M. Schneider, A. Redondas, F. Hase, T. Blumenstock, S. Kühl and Y. González: Ozone monitoring from space-based EUMETSAT/IASI-A and IASI-B sensors and comparison to ground-based Brewer and FTIR spectrometers at the Izaña Observatory, Cost Action ES1207 EUBREWNET Open Congress/14th WMO-GAW BREWER Users Group Meeting EUBREWNET, 24-28 March, Santa Cruz de Tenerife, 2014.
- Gil-Ojeda, M., Navarro-Comas, M., Gómez-Martín, L., Saiz-López, A., Adame, J.A., González, Y., Puenteadura, O. and Cuevas, E., NO₂ seasonal evolution in the background North Subtropical free troposphere, NDACC/GAW/NORS Workshop, 5-7 November, Brussels, 2014.
- Gómez-Moreno, F. J., E. Alonso, B. Artúñano, S. Iglesias, Samitier, M. Piñeiro Iglesias, P. López Mahía, N. Pérez, A. Alastuey, B. A. de la Morena, M. I. García, S. Rodríguez, M. Sorribas, G. Titos, H. Lyamani, L. Alados-Arboledas, E. Filimundi, E. Latorre Tarrasa. The REDMAAS 2014 intercomparison campaign: CPC, SMPS, UFP and neutralizer. 2nd Iberian Meeting on Aerosol Science and Technology, 7-9 July, Tarragona (Spain), 2014.
- González, Y., M. Schneider, C. Dyroff, E. Christner, O.E. García, S. Rodríguez, E. Sepúlveda, R. Ramos, V. Gómez-Trueba, J. Andrey Local and large-scale MBL to FT mixing of water vapour at Tenerife as observed by water vapour isotopologues, 27th-April - 2nd May, 2014, Vienna (Austria), Geophysical Research Abstracts Vol. 16, Poster
- González, Y., M. Schneider, C. Dyroff, E. Christner, O.E. García, S. Rodríguez, and E. Sepúlveda, Water vapour isotopologues footprints observed at local and regional scales in the Subtropical North Atlantic region, NDACC-IRWG/TCCON meeting 2014, 12-16 May, Bad Sulza (Germany), 2014.
- González, Y., Schneider, M., Rodríguez, S., Cuevas, E., Dyroff, C., Christner, E., Andrey, J., García, O., Sepúlveda, E.: Measurements and interpretation of the water vapor δD variability at Izaña North Atlantic free troposphere site, Symposium on Atmospheric Chemistry and Physics at Mountain Sites, August 11-15, 2014, Steamboat Springs, CO, USA. Oral presentation.
- Goloub, P., V. Cachorro, and E. Cuevas, WP 18/TNA12 : AERONET-EUROPE Calibration Center, 4th ACTRIS General Assembly Meeting, Clermont Ferrand, France, June 12th, 2014.
- Kühl, S., O. García, A. Gómez Peláez, A. Redondas, P.M. Campos, E. Sepúlveda, M. Schneider, A. Wiegeler, S. Dohe, S. Barthlott, F. Hase and T. Blumenstock, VALIASI - Validation of IASI level 2 products by GB-FTIR measurements, NDACC-IRWG/TCCON meeting 2014, 12-16 May, Bad Sulza (Germany), 2014.
- Kühl, S., A. Gómez-Peláez, A. Redondas, P. M. Romero Campos, M. Schneider, A. Wiegeler, S. Dohe, E. Sepúlveda, Y. González, S. Barthlott, F. Hase, T. August, T. Blumenstock and O. Garcia, VALIASI: Validation of IASI trace gas retrievals by ground based FTIR measurements, EUMETSAT Conference 2014, 22-26 September, Geneva, Switzerland.
- Lakkala, K., E. Asmi, O. Meinander, B. Hamari, A. Redondas, F. Almansa, V. Carreno, H. Ochoa, G. Deferrari, Observations from the NILU-UV Antarctic network since 2000, XXXIII SCAR Biennial Meetings and Open Science Conference, August 25-28, 2014.
- Méndez-Ramos, J., P. Acosta-Mora, M. Sierra, A. Redondas, J.C. Ruiz Morales, T. Hernández, M.E. Borges, P. Esparza, Rare-earth doped up-conversion materials for enhancing photocatalytic activity of water-splitting semiconductor electrodes, San Sebastián, País Vasco, 13-16 Mayo 2014. Presentación Oral.
- Milford, C., Fernández-Camacho, R., Sánchez de la Campa, A., Rodríguez, S., Castell, N., Marrero, C., de la Rosa, J. D. and Stein, A. F., Measurements and modelling of black carbon in two cities in south-west Spain, 9th International Conference on Air Quality - Science and Application, Garmisch-Partenkirchen, Germany, 24-28 March 2014.
- Ostler, A., R. Sussmann, M. Rettinger, T. Blumenstock, N.M. Deutscher, S. Dohe, D.W.T. Griffith, F. Hase, N. Jones, J. Notholt, M. Palm, P.K. Patra, and O.E. García. Multi-station intercomparison of column-averaged methane from NDACC and TCCON: Impact of dynamical variability.

- Redondas, A., Carreño V, Rodríguez J.J. "Comparison of Toronto and Izaña Triad" COST ACTION ES1207 European Brewer Network. Netherlands, Delft, 11th, November, 2014.
- Redondas, A., Carreño V, Rodríguez J.J."UV- Arosa 2014 Campaign reprocessing" COST ACTION ES1207 European Brewer Network. Netherlands, Delft, 11th, November, 2014.
- Redondas, A., B.H. Cruz "Eubrewnet – Database Global View" COST ACTION ES1207 European Brewer Network. Netherlands, Delft, 11th, November, 2014.
- Redondas, A., B.H. Cruz "Eubrewnet – Database Global View" COST ACTION ES1207 European Brewer Network. Netherlands, Delft, 11th, November, 2014.
- Redondas, A., Evans, R., Stuebi, R., Köhler, U., and Weber, M., "Effect of the ozone cross section in total ozone in Brewer algorithms," COST ACTION ES1207 EUBREWNET OPEN CONGRESS /14th WMO-GAW BREWER USERS GROUP MEETING EUBREWNET & WMO GAW, Tenerife, 24-28 March 2014.
- Redondas A, Rodríguez M, Brewer Calibration & Brewer error budget Kickoff Meeting of ATMOZ (TRACEABILITY FOR ATMOSPHERIC TOTAL COLUMN OZONE) project Davos Switzerland , 10-12 October 2014.
- Redondas, A., Rodríguez-Franco J.J.,Carreño, V., and Sierra, M., "Ten years of the Regional Brewer Calibration Center- Europe" COST ACTION ES1207 EUBREWNET OPEN CONGRESS /14th WMO-GAW BREWER USERS GROUP MEETING EUBREWNET & WMO GAW, Tenerife, 24-28 March 2014
- Robles González, C. , Navarro, M. , Puentedura, O., Garcia, O.E., Hase, F., Schneider, M., Cuevas, E. and Gil-Ojeda, M., Intercomparison of NO₂ total column derived from DOAS and FTIR over the subtropical NDACC Izaña observatory from 2000 to 2012 and validation of OMI and SCIAMACHY NO₂ products, NDACC/GAW/NORS Workshop, 5-7 November, Brussels, 2014.
- Rodríguez-Franco, J.J., and E. Cuevas, Subtropical tropopause characterization using long-term ozonesonde data series over Tenerife, XXXIII Jornadas Científicas de la AME, Tiempo Clima y Sociedad, Oviedo, Spain, April 7-9, 2014.
- Rodríguez-Franco J.J., Redondas, A., "Brewer Aerosol Optical Depth (AOD) Calibration: long term stability" COST ACTION ES1207 European Brewer Network. Netherlands, Delft, 11th, November, 2014.
- Rodríguez-Franco J.J.,Redondas, A.,Carreño, V., and Sierra, M., "Regional Brewer Calibration Center - Europe intercomparison campaigns: instrumental findings" COST ACTION ES1207 EUBREWNET OPEN CONGRESS /14th WMO-GAW BREWER USERS GROUP MEETING EUBREWNET & WMO GAW, Tenerife, 24-28 March 2014
- Rodríguez, J.M. Prospero, M.I. García, A. Alastuey, R.D. García, J. López-Solano, E. Cuevas, X. Querol, Long term 1987 - 2012 trends of sulfate, nitrate and dust mixing in the Saharan Air Layer. Symposium on Atmospheric Chemistry and Physics at Mountain Sites, Steamboat Springs, CO, USA., August 11-15, 2014.
- Salvador, P., Artíñano, B., Gómez-Moreno, F. J., Alonso,S., Pey, J., Alastuey, A., and Querol. X. Characterization of African dust source areas contributing to ambient aerosol levels across the western Mediterranean basin. 2nd Iberian Meeting on Aerosol Science and Technology, 7-9 July, Tarragona (Spain), 2014.
- Schneider, M., S. Barthlott, E. Christner, Y. González, A. Wiegele, C. Dyroff, T. Blumenstock, O. E. García, F. Hase, U. Raffalski, E. Sepúlveda, Feasibility and usefulness of tropospheric water vapour isotopologue ratio remote sensing products, Climate Symposium 2014, 13-17 October, Darmstadt (Germany), 2014.
- Schneider, M., T. Blumenstock, F. Hase, O.E. García and E. Sepúlveda, Izaña site report, NDACC-IRWG/TCCON meeting 2014, 12-16 May, Bad Sulza (Germany), 2014.
- Schneider, M., Y. González, C. Dyroff, E. Christner, O.E. García, A. Wiegele, J. Andrey, S. Barthlott, T. Blumenstock, C. Guirado, F. Hase, R. Ramos, S. Rodríguez, E. Sepúlveda. Intercomparison of in-situ and remote sensing δD signals of tropospheric water vapour
- Schneider, M., et al., MUSICA update, NDACC-IRWG/TCCON meeting 2014, 12-16 May, Bad Sulza (Germany), 2014.
- Sepúlveda, E., O. García, M. Schneider, F. Hase, T. Blumenstock, S. Köhl, A. Gómez-Peláez, P. M. Romero-Campos and Y. González, Consistency between IASI-A and IASI-B operational trace gas products in the Subtropical North Atlantic Region. Comparison to ground-based FTIR at the Izaña Observatory, EUMETSAT Conference 2014, 22-26 September, Geneva, Switzerland.
- Sepúlveda,E., M. Schneider, F. Hase, S. Barthlott, D. Dubravica, O.E. García, A. Gómez-Peláez, Y. González, J.C. Guerra, M. Gisi, R. Kohlhepp, S. Dohe, T. Blumenstock, K. Strong, D. Weaver, M. Palm, A. Sadeghi, N.M. Deutscher, T. Warneke, J. Notholt, N. Jones, D.W.T. Griffith, D. Smale, G.W. Brailsford, J. Robinson, F. Meinhardt, M. Steinbacher, T. Aalto, D. Worthy. Tropospheric CH₄ signals as observed by NDACC FTIR at globally distributed sites and comparison to GAW surface in-situ measurements, NDACC-IRWG/TCCON meeting 2014, 12-16 May, Bad Sulza (Germany), 2014.
- Sierra, M., J. Méndez-Ramos, M. E. Borges, A. Redondas, P. Acosta-Mora, P. Esparza and J. C. Ruiz-Morales, "Up-conversion photonics in rare-earth doped materials for enhancing incoming UV solar irradiation", Davos, Suiza, 15-16 Julio 2014. Poster Presentation.
- Sierra, M., J.J Rodríguez, A. Redondas, V. Carreño, ESA CAL_VAL campaign during 28th October to 18th November 2011 "Improvements in UV laboratory measurements at Izaña Atmospheric Research Center". COST ACTION ES1207 EUBREWNET OPEN CONGRESS /14th WMO-GAW BREWER USERS GROUP MEETING EUBREWNET & WMO GAW, Tenerife, 24-28 de Marzo 2014. Poster Presentation.
- The ozone SAG: Stratospheric ozone in the Global Atmosphere Watch Programme 13th Quadrennial iCACGP Symposium/13th IGAC Science Conference. Natal, Brazil. July 2014
- Weaver, D., K. Strong, M. Schneider, N. Deutscher, T. Blumenstock, J. Robinson, J. Notholt, V. Sherlock, D.W.T. Griffith, S. Barthlott, O.E. García, M. Palm, N. Jones, F. Hase, R. Kivi, Y. González, E. Sepúlveda, M. Gisi, T. Warneke, S. Dohe, R. Kohlhepp, A. Wiegele, E. Christner, B. Lejeune, and P. Demoulin, Intercomparison of MUSICA and TCCON water vapour products, AGU Fall Meeting, San Francisco, 15-19 December, 2014.
- Wiegele, A., NDACC/FTIR as an essential validation resource of METOP/IASI water vapour isotopologue data, NDACC-IRWG/TCCON meeting 2014, 12-16 May, Bad Sulza (Germany), 2014.

2013

- Blumenstock, T., R. Kohlhepp, S. Barthlott, O. E. García, F. Hase, M. Kiefer, U. Raffalski, M. Schneider: Investigation of long-term Stability of MIPAS-ENVISAT O₃ and HNO₃ Data using ground-based FTIR Measurements in Kiruna (S) and Izaña (E), ACVE Conference 2013, ESA-ESRIN, Frascati, Italia, 13-15 Marzo 2013.
- Carreño V, Redondas, A, Rodriguez J, Sierra M, RBCC-E Update Triad Status. COST 1207 European Brewer Network , Manchester UK, 26-27 September 2013
- Chevallier, F., E. J. Dlugokencky, T. Aalto, E. G. Brunke, L. Ciattaglia, Y. Esaki, M. Fröhlich, A. Gomez, A. J. Gomez-Pelaez, L. Haszpra, P. B. Krummel, R. L. Langenfelds, M. Leuenberger, J. A. Morguá, H. Mukai, T. Nakazawa, C. W. O'Dell, M. Ramonet, Y. Sawa, M. Schmidt, L. P. Steele, A. T. Vermeulen, D. Worthy, M. Zimnoch, "33 years of CO₂ surface fluxes as seen from the atmosphere", 9th International Carbon Dioxide Conference, Beijing, China, 3-7 June 2013
- Christner, E., Dyroff, C., Kohler, M., Zahn, A., González, Y., Schneider, M., Seasonal, synoptic and diurnal variation of atmospheric water-isotopologues in the boundary layer of Southwestern Germany caused by plant transpiration, cold-front passages and dewfall, European Geosciences Union General Assembly (EGU)-2013, 7-12 April 2013, Viena (Austria), 2013, (presentación oral).
- Cuevas, E., S. Basart, Validation of dust in the MACC reanalysis over the Sahel, Joint AER-GRG-VAL meeting, Wermelskirchen, Germany, 26-28 June 2013.
- Cuevas, E., J.M. Baldasano, X. Zhang, W. Sprigg, E. Terradellas, and S. Nickovic, SDS-WAS Research and Development activities, 6th meeting of the WWRP JSC, Geneva, 18-19 July 2013.
- Cuevas, E., J.M. Baldasano, X. Zhang, W. Sprigg, E. Terradellas, S. Basart, S. Nickovic, SDS-WAS Research and Development activities, WMO-CAS-16 meeting, Antalya, Turkey, 20-26 November 2013.
- Cuevas, E., A. Gómez-Peláez, A. Redondas, O. García, S. Rodríguez, R. Ramos, P.M. Romero-Campos, R.D. García, Y. González, A. Berjón, C. Guirado, J.J. Rodríguez, J.J. Bustos, The Izaña Atmospheric Research Center: GAW activities, GAW-2013 Symposium, Geneva, Switzerland, 18-20 March, 2013.
- Cuevas, E., WMO Sand and Dust Storm Warning Advisory and Assessment System (SDS-WAS), Meteorology for the League of Arab States (PCMLAS), Marrakech 8-10 April, 2013.
- Cuevas, E., Sand and Dust Storms Historical Trends and Pathways - Regional Assessment, Technical Meeting on the Regional Programme to Combat Sand and Dust Storms (SDS), Abu Dhabi, United Arab Emirates, 6-7 May 2013.
- Cuevas, E., Specific recommendations to implement the WMO SDS WAS Regional node for West Asia, Technical Meeting on the Regional Programme to Combat Sand and Dust Storms (SDS), Abu Dhabi, United Arab Emirates, 6-7 May 2013.
- Dohe, S., Sherlock, V., Hase, F., Gisi, M., Robinson, J., Sepúlveda, E., Schneider, M., y Blumenstock, T.: Correction of sampling ghosts, IRWG/TCCON Meeting 2013, Abashiri, Japan (oral presentation), 10-14 June, 2013.
- García, R.D., Cachorro, V.E., and Cuevas, E.: Determination of the underlying effective albedo at Izaña high mountain station. The Davos Atmosphere and Cryosphere Assembly -DACA 2013 Davos, Switzerland, 8-13 July 2013
- García, R.D., O.E. García, E. Cuevas, V.E. Cachorro, P.M. Romero-Campos, R. Ramos and A.M. de Frutos, Mineral dust radiative forcing and efficiency at the BSRN Izaña station, The 1st Iberian Meeting on Aerosol Science and Technology – RICTA 2013, Evora, Portugal, 1-3 July 2013.
- García, O.E., M. Schneider, F. Hase, T. Blumenstock, A. Wiegeler, E. Sepúlveda, A. Gómez-Peláez: Validation of the IASI operational CH₄ and N₂O products using ground-based Fourier Transform Spectrometers. Preliminary results at the Izaña Observatory (28°N, 17°W), ACVE Conference 2013, ESA-ESRIN, Frascati, Italia, 13-15 Marzo 2013.
- García, O.E., M. Schneider, F. Hase, A. Wiegeler, T. Blumenstock, E. Sepúlveda, A. Gómez-Peláez, S. Barthlott: Validation of IASI Level 2 Atmospheric Trace Gas Products using ground-based Fourier Transform Spectrometers: Projects VALIASI and NOVIA, IASI Conference 2013, Hyères (Francia) del 4 al 8 de Febrero de 2013.
- García, O.E., Schneider, M., Hase, F., Wiegeler, A., Blumenstock, T., Sepúlveda, E., August, T., Gómez-Peláez, A., Barthlott, S., González, Y.: Validation of EUMETSAT's Operational IASI Trace Gas Products by ground-based FTIR: the Projects VALIASI and NOVIA, IRWG/TCCON Meeting 2013, Abashiri, Japan (oral presentation), 10-14 June, 2013.
- Goloub, P., V. Cachorro and E. Cuevas, Service for Calibration / Maintenance Facilities dedicated to Aerosols monitoring, ACTRIS Project ACTRIS MTR Meeting - Brussels, Belgium, 6-7 June, 2013.
- Gómez-Moreno, F.J., E. Alonso, B. Artíñano, V. Juncal Bello, M. Piñeiro Iglesias, P. López Mahía, N. Pérez, J. Pey, A. Alastuey, B. A. de la Morena, M. I. García, S. Rodríguez, M. Sorribas, G. Titos, H. Lyamani, and L. Alados-Arboledas, The REDMAAS 2012 SMPS+UFP intercomparison campaign, The 1st Iberian Meeting on Aerosol Science and Technology – RICTA 2013, Evora, Portugal, 1-3 July 2013.
- González, Y., C. López, and E. Cuevas, Cloud Nowcasting: Motion Analysis of All-Sky Images using Velocity Fields, 19th IMEKO TC-4 Symposium, Measurements of Electrical Quantities Advances in Instrumentation and Sensors Interoperability, Barcelona, 18-19 July, 2013
- González, Y., Schneider, M., Christner, E., Rodríguez, O.E., Sepúlveda, E., Christoph Dyroff, C., and Wiegeler, A., First observations of tropospheric data observed by ground- and space-based remote sensing and surface in-situ measurement techniques at MUSICA's principle reference station (Izaña Observatory, Spain), European Geosciences Union General Assembly (EGU)-2013, 7-12 April 2013, Viena (Austria), 2013.
- Hase, F., Schneider, M., Barthlott, S., Christner, E., González, Y., Yoshimura, K., García, O. E., Sepúlveda, E., Gomez-Pelaez, A., Dohe, S., Blumenstock, T., Wiegeler, A., Cyroff, C., Strong, K., Weaver, D., Palm, M., Deutscher, N. M., Warneke, T., Notholt, J., Demoulin, P., Mahieu, E., Jones, N., Griffith, D. W. T., Smale, D., Robinson, J., Zahn, A., and Orphal, J.: Recent progress in remote sensing of tropospheric water vapour isotopologues, High Resolution Molecular Spectroscopy Conference, August 25-30, Budapest, Hungary, 2013.
- Henne, S., M. Steinbacher, E. Mahieu, W. Bader, T. Blumenstock, E. Cuevas-Agulló, D. Brunner, and B. Buchmann, Comparison of ground-based remote sensing and in-situ observations of CO, CH₄ and O₃, accounting for representativeness uncertainty, European Geosciences Union (EGU) General Assembly 2013. Geophysical Research Abstracts, EGU2013-8274, 07-12 April, 2013. Viena, Austria.

- Redondas A, Calibration Issues during RBCC-E campaigns, COST 1207 European Brewer Network , Manchester UK, 26-27 September 2013
- Redondas, A. Brewer Spectrometer Calibration Methodology at RBCC-E, COST 1207 European Brewer Network, Manchester UK, 26-27 Septiembre 2013.
- Redondas A, Evans R, Kohler U ,Stuebi R, Weber M, Effect of the ozone cross section in total ozone in Dobson and Brewer algorithms. ACSO (Absorption Cross Section of Ozone) 2013 Workshop . Geneva , Switzerland , 1-3 June 2013
- Redondas, A.; Köhler, U, Kyrö, E, Evans R.D. On the Quality of the Total Ozone Dobson and Brewer Measurements: Results of the ESA-CALVAL Campaigns . ESA Living Planet 9-13 September 2013
- Redondas, A, Rodriguez J, Sierra M, Carreño V, REGIONAL BREWER CALIBRATION CENTER -EUROPE. GAW 2013 Symposium, 18-20 March 2013 WMO Secretariat, Switzerland,Geneva
- Redondas, A., J.J. Rodríguez, M. Sierra, and V. Carreño, Regional Brewer Calibration Center- Europe, GAW-2013 Symposium, Geneva, Switzerland, 18-20 March, 2013.
- Redondas, A, Rodriguez J, Sierra M, Carreño V RBCC-E Update Huelva Campaign. COST 1207 European Brewer Network , Manchester UK, 26-27 September 2013
- Robles González, C., M. Navarro, O. Puentedura, F. Hase, M. Schneider, E. Cuevas, and M. Gil Ojeda, Intercomparison of the NO₂ vertical column densities measured over Izaña with two ground-based remote sensing techniques: DOAS and FTIR, XV Congreso de la Asociación Española de Teledetección (AET), INTA, Madrid, 22-24 October, 2013.
- Rodríguez de la Rosa J. ,Redondas,A. RBCC-E Web Site and Software Proposal.COST 1207 European Brewer Network, Manchester UK, 26-27 Septiembre 2013.
- Rodriguez, S.,E. Cuevas, A. Dominguez-Rodriguez. Protection of human health through dust storm modeling. MACC II / GMES PURE Atmosphere Service user workshop. Harwell, UK, 12 June 2013.
- Rodriguez J , Redondas A , RBCC-E Web Site and Software Proposal. COST 1207 European Brewer Network , Manchester UK, 26-27 September 2013
- Sepúlveda, E., Schneider, M., Hase, F., García, O.E., Barthlott, S., González, Y., Gisi, M., Kohlhepp, R., Dohe, S., Blumenstock, T., Strong, K., Weaver, D., Palm, M., Sadeghi, A., Deutscher, N.M., Warneke, T., Notholt, J., Bader, W., Mahieu, E., Jones, N., Griffith, D.W.T., Smale, D., Sherlock, V., Robinson, J., A. Gomez-Peleaz, F. Meinhardt, M. Steinbacher. T. Aalto: Tropospheric CH₄ as observed by NDACC FTIR and GAW at several globally distributed sites, IRWG/TCCON Meeting 2013, Abashiri, Japan (oral presentation), 10-14 June, 2013.
- Schneider, M., Barthlott, S., Hase, F., González, Y., Yoshimura, K., García, O.E., Sepúlveda, E., Gómez-Peláez, A., Gisi, M., Kohlhepp, R., Dohe, S., Blumenstock, T., Wiegeler, A., Christner, E., Strong, K., Weaver, D., Palm, M., Deutscher, N.M., Warneke, T., Notholt, J., Lejeune, B., Demoulin, P., Jones, N., Griffith, D.W.T., Smale, D., Robinson, J., MUSICA activities, IRWG/TCCON Meeting 2013, Abashiri, Japan (oral presentation), 10-14 June, 2013.
- Schneider, M., Hase, F., Blumenstock, T., García, O.E., Sepúlveda, E.: The Izaña site report, IRWG/TCCON Meeting 2013, Abashiri, Japan (oral presentation), 10-14 June, 2013
- Schneider, M., A. Wiegeler, F. Hase, S. Barthlott, T. Blumenstock, O.E. García, E. Sepúlveda: IASI / METOP retrievals within the project MUSICA, IASI Conference 2013, Hyères (Francia) del 4 al 8 de Febrero de 2013.
- Terradellas, E, Baldasano, JM, Cuevas, E, Basart, S, Huneeus, N, Camino, C, Dondar, C, Benincasa, F., Evaluation of atmospheric dust prediction models using ground-based observations, European Geosciences Union (EGU) General Assembly 2013. Geophysical Research Abstracts, EGU2013-8274, 07-12 April, 2013. Viena, Austria.
- Terradellas, E., E. Cuevas, and J.M. Baldasano, WMO Sand and Dust Storm Warning Advisory and Assessment System: Regional Center for Northern Africa, Middle East and Europe, GAW-2013 Symposium, Geneva, Switzerland, 18-20 March, 2013.
- Torres, B., C. Toledano, A.J. Berjón, D.Fuertes, V. Molina, R. González, M. Canini, V.E. Cachorro, P. Goloub, T. Podvin, L. Blarel, O. Dubovik, Y. Bennouna, A.M. de Frutos, Pointing error and field of view of AERONET Cimel-318 Sun photometers, The 1st Iberian Meeting on Aerosol Science and Technology – RICTA 2013, Evora, Portugal, 1-3 July 2013.
- Torres, B., C. Toledano, O. Dubovik, V.Cachorro, A.J. Berjón, T. Lapyonak, P. Goloub, A first comparison between almucantar and principal plane retrieval products within AERONET network, The 1st Iberian Meeting on Aerosol Science and Technology – RICTA 2013, Evora, Portugal, 1-3 July 2013.
- Vigouroux, C, M. De Mazière, P. Demoulin, C. Servais, T. Blumenstock, F. Hase, R. Kohlhepp, S. Barthlott, O. García, M. Schneider, J. Mellqvist, G. Personn, M. Palm, J. Notholt, J. Hannigan, M. Coffey, D. Smale, B. Liley, V. Sherlock, N. Jones, T. Nagahama, H. Nakajima, R. Kivi, Vertical ozone trends from NDACC FTIR observations, SPARC Ozone Profile Phase II Initiative (SI2N)-Workshop, September 18-19, Helsinki (Finland), 2013.
- Vigouroux, C., M. De Mazière, P. Demoulin, C. Servais, T. Blumenstock, F. Hase, R. Kohlhepp, S. Barthlott, O. García, M. Schneider, J. Mellqvist, G. Personn, M. Palm, J. Notholt, J. Hannigan, M. Coffey, Ozone tropospheric and stratospheric trends (1995-2012) at six ground-based FTIR stations (28°N to 79°N), European Geosciences Union General Assembly (EGU)-2013, 7-12 April 2013, Viena (Austria), 2013.
- Vigouroux, C., et al., Ozone variability and trends from ground-based FTS network observations, IRWG/TCCON Meeting 2013, Abashiri, Japan (oral presentation), 10-14 June, 2013.

2012

- Arroyo-Ucar, E., A. Dominguez Rodriguez, R. Juarez-Prera, J. Abreu-Afonso, Y. Gonzalez, S. Rodríguez, MC. Perez-Tome, A. Jimenez-Sosa, P. Abreu-Gonzalez, P. Avanzas. The short-term exposure to atmospheric sulphur dioxide is associated with significant obstructive lesions in acute coronary syndrome. Acute Cardiac Care 2012. Istanbul – Turkey. AÑO: 20-23 Oct 2012.
- Barreto, A., E. Cuevas, B. Damiri, C. Guirados, P. M- Romero and A. F. Almansa, Characterization of nocturnal AOD and Water Vapour using lunar photometer CE318U2012 European Aerosol Conference (EAC-2012), A-WG02S1P37, Granada-Spain, 2- 7 September, 2012.
- Bennouna, Y., V. Cachorro, B. Torres, R. Rodrigo, C. Toledano, A. Berjón, A. De Frutos, Nine years of aerosol optical depth measurements over north-central Spain from ground (AERONET-RIMA) and their comparison with satellite (MODIS) observations, 2012 European Aerosol Conference

- (EAC-2012), B-WG01S2P20, Granada-Spain, 2- 7 September, 2012.
- Belmonte, J., C. De Linares, A. Fernández-Llamazares, C. Díaz de la Guardia, P. Cariñanos, S. Alonso-Pérez, E. Cuevas, J.M. Maya, S. Fernández, I. Silva, R. Tormo, Airborne Pinus pollen in Spain: pollination patterns and trends of the annual indexes and the peak dates, 5th European Symposium on Aerobiology, Krakow, Poland, 3 - 7 September, 2012.
- Camino, C., S. Alonso-Pérez, E. Terradellas, S. Rodriguez, A. Gomez-Pelaez, P.M. Romero-Campos, Y. Hernández, S. Basart, J.M. Baldasano and E. Cuevas, An empirical relationship to estimate mineral dust concentration from visibility observations, 2012 European Aerosol Conference (EAC-2012), A-WG02S1P52, Granada-Spain, 2- 7 September, 2012.
- Castillo, S., X. Querol, A. Alastuey, A. Ávila, E. Cuevas, Jesús De La Rosa, Influence of Saharan dust in deposition fluxes of nutrients in Spain, 2012 European Aerosol Conference (EAC-2012), A-WG02S1P37, Granada-Spain, 2- 7 September, 2012.
- Córdoba-Jabonero, C., D. Toledo, J.A. Adame, Y. Hernández, E. Cuevas, M. Gil, Saharan Air Layer (SAL) over Tenerife: Summertime statistic analysis from lidar measurements, 2012 European Aerosol Conference (EAC-2012), B-WG01S2P13, Granada-Spain, 2- 7 September, 2012.
- Córdoba-Jabonero, C., D. Toledo, J.A. Adame, Y. Hernández, E. Cuevas, M. Gil, Saharan Air Layer (SAL) over Tenerife: Summertime statistic analysis from lidar measurements, 2012 European Aerosol Conference (EAC-2012), B-WG01S2P13, Granada-Spain, 2- 7 September, 2012.
- Cuevas, E., Intrusiones de polvo en Canarias, 4 Congreso Regional Sociedad Canaria de Alergia, Tenerife, 4 - 5 de Mayo de 2012.
- Cuevas, E., C. Camino, J.M. Baldasano, E. Terradellas and S. Basart, Dust episodes over Northern Africa, Middle East and Europe in August 2012, MACC-II Second General Assembly, Toulouse, France, November, 6-8, 2012.
- Dohe, S., E. Sepúlveda, F. Hase, A. Gómez, M. Schneider, T.Blumenstock and O. García: CO₂ total column amounts at the TCCON sites Izaña (28.3°N, 16.5°W) and Karlsruhe (49.1°N, 8.5°E), International Radiation Symposium, August 06-10, 2012, Dahlem Cube, Berlin, Germany.
- Fernández-Camacho, R., S. Rodríguez, J. de la Rosa, A.M. Sánchez de la Campa, Y. González-Castanedo, Source apportionment of ultrafine and fine particles in Huelva industrial city, 2012 European Aerosol Conference (EAC-2012), A-WG01S1P28, Granada-Spain, 2- 7 September, 2012.
- García, R.D., Cuevas. E., Cachorro, V.E., Ramos. R., and de Frutos, A.M.: Comparison between measurements and model simulations of daily solar radiation at the BSRN Izaña site. 39th Annual European Meeting on Atmospheric Studies by Optical Methods, 20-24 August 2012, Sopot, Poland.
- García, R.D., Cuevas, E., Cachorro,V.E., Ramos, R., and de Frutos, A.M.: Comparison between measurements and model simulations of solar radiation at a high altitude site: Case studies for the Izaña BSRN station, International Radiation Symposium, August 06-10, 2012, Dahlem Cube, Berlin, Germany.
- García, R.D., Cuevas, E., Ramos, R., Romero-Campos, P.M., Cachorro, V.E., and de Frutos, A.M.: Status of the Izaña BSRN station, Twelfth BSRN Scientific Review and Workshop, August 01-03, 2012, AWI, Potsdam, Germany.
- García, M.I., S. Rodríguez, R.D. García, Y. González, Characterization of new particles formation events at Izaña Mountain Observatory (Tenerife, Canary Islands): formation, growth rates and influencing atmospheric parameters, 2012 European Aerosol Conference (EAC-2012), A-WG01S1P40, Granada-Spain, 2- 7 September, 2012.
- García, O., Schneider, M., Hase, F., Blumenstock, T., González, Y., Sepúlveda, E.: Comparison of long-term ozone time series obtained in different spectral infrared regions, 2012 IRWG/TCCON Meeting, June 11-15, 2012, Wengen, Switzerland.
- Gil-Ojeda, M., M. Navarro-Comas, A. Redondas, O. Puentedura, F. Hendrick, M. van-Roozendaal, J. Iglesias, E. Cuevas, Total ozone measurements from the NDACC Izaña Subtropical Station: Visible spectroscopy versus Brewer and satellite instruments, Quadrennial Ozone Symposium 2012 (QOS 2012), ID:6064, Toronto, Canada, August 27th-31th, 2012.
- Goloub, P., V. E. Cachorro, E. Cuevas, L. Blarel, A. Berjon, C. Toledano, A. Lapionak, C. Guirado, R. Ramos, R. González, D. Fuertes, The AERONET-Europe calibration facility: access within the ACTRIS Project, 2012 European Aerosol Conference (EAC-2012), B-SS01S1P12, Granada-Spain, 2- 7 September, 2012.
- Goloub, P., V. Cachorro, and E. Cuevas, AERONET-EUROPE (Service) Transnational Access for Calibration / Maintenance Facilities dedicated to Aerosols monitoring, 2nd ACTRIS General Assembly Meeting Stresa, Italy, 4-6 June 2012.
- Goloub, P., L. Blarel, T. Podvin, R. Lecoq, M. Catalfamo, A. Lapionak, C. Deroo, B. Chatenet, J-P Morel, E. Cuevas, C.Guirado, B. Holben, Service d'Observation Aerosols PHOTONS/AERONET, 2nd ACTRIS General Assembly Meeting Stresa, Italy, 4-6 June 2012.
- Gómez-Moreno, F.J., B. Artiñano, V. Juncal Bello, M. Piñeiro Iglesias, P. López-Mahía, N. Pérez, J. Pey, A. Alastuey, B. A. de la Morena, M. I. García, S. Rodríguez, M. Sorribas, G. Titos, H. Lyamani and L. Alados-Arboledas, Calibration and intercomparison results in the Spanish network on environmental DMAs, 2012 European Aerosol Conference (EAC-2012), B-WG01S2P30, Granada-Spain, 2- 7 September, 2012.
- Gomez-Pelaez, A.J., J.A. Morguá, R. Curcoll, E. Cuevas, R. Ramos, X. Rodó, and M.J. Sanz, Future ICOS-Spain atmospheric stations, 4th ICOS Atmosphere Workshop, Gif-sur-Yvette, France, February 16-17, 2012.
- Gonzalez, Y, C. López, and E. Cuevas, Automatic Observation of Cloudiness: Analysis of All-Sky Images, TECO-2012, WMO Technical Conference on Meteorological and Environmental Instruments and Methods of Observation, Session 3, Meeting the needs of climate observations, Brussels, Belgium, 16-18 October 2012.
- Hammer, S., A. Gomez-Pelaez, M. Schmidt, A. Jordan, T. Laurila, R. Curcoll and A. Manning "Working group 6: Quality management for atmospheric ICOS stations". 5th ICOS Atmosphere Workshop, Arona, Italy, 8 and 9 October 2012.
- Hernández, Y., S. Alonso-Pérez, E. Cuevas, J. de Bustos, A. Gomez-Pelaez, R. Ramos, C. Córdoba-Jabonero. and M. Gil, Planetary Boundary Layer and Saharan Air Layer top height determination using Ceilometer and Micro Pulse Lidar. Intercomparison for two case studies, 2012 European Aerosol Conference (EAC-2012), A-WG02S1P51, Granada-Spain, 2- 7 September, 2012.

- Karppinen, T., A. Redondas, R. García, K. Lakkala, C.T. McElroy, and E. Kyro, Correcting Stray Light in Single-monochromator Brewer Spectrophotometers, Quadrennial Ozone Symposium 2012 (QOS 2012), ID:6155, Toronto, Canada, August 27th-31th, 2012
- Köler, U., A. Redondas, E. Kyro, Regional Calibration Centers for Dobson and Brewer in Europe - A joint venture for highest quality in monitoring the ozone layer, Quadrennial Ozone Symposium 2012 (QOS 2012), ID:5967, Toronto, Canada, August 27th-31th, 2012.
- Milford, C., N. Castell, C. Marrero, A. Sánchez de la Campa, R. Fernández-Camacho, S. Rodríguez, J. D. de la Rosa and A. F. Stein, Modelling of Secondary Aerosols in Urban and Rural Areas of Southwest Spain, 8th International Conference on Air Quality - Science and Application Air Quality 2012, Athens, Greece, 19-23 March 2012.
- Milford, C., N. Castell, C. Marrero, A. Sánchez de la Campa, R. Fernández-Camacho, S. Rodríguez, J. D. de la Rosa and A. F. Stein, Modelling PM2.5 chemical composition with CAMx in southwest Spain, 2012 European Aerosol Conference (EAC-2012), C-WG09S1P12, Granada-Spain, 2- 7 September, 2012.
- Perlwitz, J., Pérez, C., Miller, R., Rodriguez S. Evaluation of a new soil dust scheme with mineralogical composition in the NASA GISS Earth System Model. American Geophysical Union 2012. San Francisco, USA. 3-7 Dic 2012.
- Perlwitz, J.P., C. Pérez, Ron I. Miller and S. Rodríguez. Atmospheric iron from crustal sources: prognostic aerosol composition in GISS/ModelE. Goldschmidt 2012. Montréal, Canada. June 24-29, 2012.
- Querol, X., A. Alastuey, M. Viana, T. Moreno, C. Reche, M.C. Minguillón, A. Ripoll, M. Pandolfi, F. Amato, N. Pérez, J.Pey, M. Cusack, R. Vázquez, J. de la Rosas, A. Sánchez de la Campa, S. Rodríguez, C. Pío, L. Alados-Arboledas, G. Titos, B. Atiñano, P. Salvador, S. García Dos Santos, R. Fernández Patier, Levels of carbonaceous aerosols in remote, rural, urban and industrial sites of Spain, 2012 European Aerosol Conference (EAC-2012), WG05S2O01, Granada-Spain, 2- 7 September, 2012.
- Redondas, A., WMO Ozone Scientific Advisory Group, Annual Meeting of the Nordic Ozone and UV Group; 08-10 February 2012.
- Redondas, A., and J.J. Rodríguez; Is possible to calibrate in early spring Artic conditions?; Annual Meeting of the Nordic Ozone and UV Group; 08-10 February 2012.
- Redondas, A., J.J. Rodriguez, Regional Brewer Calibration Center - Europe CEOS campaigns: instrumental findings, Quadrennial Ozone Symposium 2012 (QOS 2012), ID:6166, Toronto, Canada, August 27th-31th, 2012.
- Redondas, A., J.M. Vilaplana, J.J. Rodríguez, T.McElroy, V. Savastiouk, G. Hülsen, K. Lamb, M. Stanek, Z. Taoufik, M. Lopez-Bartolomé, J. Rimmer, C. Lee, C.E.O.S. RBCC-E Huelva intercomparison results, Quadrennial Ozone Symposium 2012 (QOS 2012), ID:6161, Toronto, Canada, August 27th-31th, 2012.
- Rodriguez, S., Izaña Atmospheric Research Centre: research and monitoring activities in the North Atlantic free troposphere. Istituto Nazionale de Fisica Nucleare, 8 October 2012, Florence, Italy.
- Schneider, M., Hase, F., Barthlott, S., Gisi, M., Blumenstock, T., González, Y., García, O., Sepúlveda, S., Yoshimura, K., Strong, K., Notholt, J., Palm, M., Warneke, T., Mahieu, E., Lejeune, B., Griffith, D., Deutscher, N., Sherlock, V., Smale, D., Wood, S.: Ground-based remote sensing of tropospheric water vapour isotopologues at ten globally distributed NDACC sites, 2012 IRWG/TCCON Meeting, June 11-15, 2012, Wengen, Switzerland.
- Schneider, M., Hase, F., García, O. E., Validation of IASI with gb FTIR, GEWEX/ESA DUE GlobVapour Final Meeting, 24 January 2012, ESA/ESRIN, Frascati, Italy.
- Sepúlveda, E., Schneider, M., Hase, F., Blumenstock, T., Gómez, A., García, O., Dohe, S., Guerra, J.G.: Update of the CH4 MIR and NIR remote sensing studies at Izaña, 2012 IRWG/TCCON Meeting, June 11-15, 2012, Wengen, Switzerland.
- Sepúlveda, E., M. Schneider, F. Hase, O.E. García, M. Gisi, T. Blumenstock, S. Dohe, Y. Gonzalez, and J.C. Guerra: Compact and low resolution spectrometer for the inversion of water vapour total column amounts, International Radiation Symposium, August 06-10, 2012, Dahlem Cube, Berlin, Germany.
- Sierra, M., Rodríguez, J.J. and Redondas, A., ESA CAL_VAL campaign during 28th October to 18th November 2011: Uv laboratory measurements at Izaña Atmospheric Research Center; Annual Meeting of the Nordic Ozone and UV Group; 08-10 February 2012.
- Terradellas, E., J.M. Baldasano, E. Cuevas, Atmospheric Sand and Dust Forecast Prévision du sable et la poussière atmosphérique, 5th Meeting of the Conference of Directors of West Africa National Meteorological and Hidrologycal Services (V-AFRIMET), Baoadilla del Campo, Madrid, 22-24 October, 2012.
- Terradellas, E., C. Camino, S. Alonso-Pérez, S. Basart, J.M. Baldasano, E. Cuevas, Distribución espacial y temporal de polvo mineral atmosférico en el norte de África y Oriente medio estimada a partir de la visibilidad horizontal, XXXII Jornadas Científicas de la AME: Meteorología y Calidad del Aire. Alcobendas, 28-30 Mayo 2012.
- Toledo, D., C. Córdoba-Jabonero, E. Cuevas, M.I Gil, Atmospheric boundary layer height estimation by different methods: Application to lidar measurements, 2012 European Aerosol Conference (EAC-2012), B-WG01S2P13, Granada-Spain, 2- 7 September, 2012.
- Torres, B., C. Toledano, A. J. Berjon, O. Dubovik, V. E. Cachorro, Y. Bennouna, D. Fuertes, R. González, P. Goloub, T. Podvin, L. Barel, A. M. de Frutos, Study on the influence of different error sources on sky radiance measurements and inversion-derived aerosol products in the frame of AERONET, 2012 European Aerosol Conference (EAC-2012), WG01S3O04, Granada-Spain, 2- 7 September, 2012.
- Viatte, C., P. Chelin², J. Orphal³, M. Schneider, B. Gaubert, A. Redondas, M. Eremenko, F. Hase, T. Blumenstock, M. Ray, J.M. Flaud, Measurements of atmospheric trace gases using Fourier-Transform Infrared Spectroscopy at Izaña (Tenerife) and using a new observatory (OASIS) at Créteil near Paris (France), Quadrennial Ozone Symposium 2012 (QOS 2012), ID:6111, Toronto, Canada, August 27th-31th, 2012.

26.3 Non-peer reviewed papers and reports

2014

- Antonakaki, T., A. Arola, A. Benedictow, A. Blechschmidt, I. Bouarar, S. Chabrillat, H. Clark, E. Cuevas, H. Flentje, A. Gaudel, J. Kapsomenakis, S. Kinne, B. Langerok, K. Lefever, M. Razinger, A. Richter, M. Schulz, V. Thouret, M. Vrekoussis, A. Wagner, C. Zerefos. Validation report of the MACC near-real time global atmospheric composition service System evolution and performance statistics Status up to 1 December 2013. MACC-II Deliverable D82.11, MACC-II Grant agreement n°283576. 87 pp. Eds: H.J. Eskes, V. Huijnen, A. Wagner, M. Schulz, K. Lefever. info@copernicus-atmosphere.eu. 18 March 2014.
- Antonakaki, T., A. Arola, A. Benedictow, A. Blechschmidt, E. Botek, I. Bouarar, S. Chabrillat, Y. Christophe, H. Clark, E. Cuevas, H. Flentje, A. Gaudel, J. Kapsomenakis, S. Kinne, B. Langerok, M. Razinger, A. Richter, M. Schulz, V. Thouret, M. Vrekoussis, A. Wagner, C. Zerefos. Validation report of the MACC near-real time global atmospheric composition service System evolution and performance statistics Status up to 1 March 2014. MACC-II Deliverable D82.12, MACC-II Grant agreement n°283576. 91 pp. Eds: H.J. Eskes, V. Huijnen, A. Wagner, M. Schulz, E. Botek. info@copernicus-atmosphere.eu. 5 June 2014.
- Antonakaki, T., A. Arola, A. Benedictow, A. Blechschmidt, E. Botek, S. Chabrillat, Y. Christophe, E. Cuevas, H. Flentje, A. Gaudel, J. Kapsomenakis, S. Kinne, B. Langerok, M. Razinger, A. Richter, M. Schulz, V. Thouret, M. Vrekoussis, A. Wagner, C. Zerefos. Validation report of the MACC near-real time global atmospheric composition service System evolution and performance statistics Status up to 1 June 2014. MACC-III Deliverable D37.1, MACC-III Grant agreement n°633080. 90 pp. Eds: H.J. Eskes, V. Huijnen, A. Wagner, M. Schulz, E. Botek. info@copernicus-atmosphere.eu. 30 September 2014.
- Antonakaki, T., A. Arola, A. Benedictow, A. Blechschmidt, E. Botek, S. Chabrillat, Y. Christophe, E. Cuevas, H. Flentje, A. Gaudel, J. Kapsomenakis, S. Kinne, B. Langerok, M. Razinger, A. Richter, M. Schulz, V. Thouret, M. Vrekoussis, A. Wagner, C. Zerefos. Validation report of the MACC near-real time global atmospheric composition service System evolution and performance statistics Status up to 1 September 2014. MACC-III Deliverable D37.2, MACC-III Grant agreement n°633080. 88 pp. Eds: H.J. Eskes, V. Huijnen, A. Wagner, M. Schulz, E. Botek. info@copernicus-atmosphere.eu. 28 November 2014.
- Benedictow, A., A. Blechschmidt, I. Bouarar, E. Botek, S. Chabrillat, Y. Christophe, E. Cuevas, H. Clark, H. Flentje, A. Gaudel, J. Griesfeller, V. Huijnen, N. Huneus, L. Jones, J. Kapsomenakis, S. Kinne, B. Langerok, M. Razinger, A. Richter, M. Schulz, W. Thomas, V. Thouret, M. Vrekoussis, A. Wagner, C. Zerefos. Validation report of the MACC reanalysis of global atmospheric composition: Period 2003-2012a>. MACC-II Deliverable D83.6, MACC-II Grant agreement n°283576. 96 pp. Eds: H.J. Eskes, V. Huijnen, A. Wagner, M. Schulz, E. Botek. info@copernicus-atmosphere.eu. 29 July 2014.
- Cuevas, E., Laboratorio Atmos-Sphaira: de la predicción Meteorológica a la Predicción Atmosférica, p 7, Tiempo y Clima, n°46 Revista de Divulgación Científica y Boletín de la Asociación Meteorológica Española, ISSN 2340-6607, Octubre 2014
- Henk, E., Antonakaki, T., A. Arola, A. Benedictow, A. Blechschmidt, E. Botek, S. Chabrillat, Y. Christophe, E. Cuevas, H. Flentje, A. Gaudel, J. Kapsomenakis, S. Kinne, B. Langerok, M. Razinger, A. Richter, M. Schulz, V. Thouret, M. Vrekoussis, A. Wagner, C. Zerefos. Supplementary validation for the regional air quality services – a proposed methodology. MACC-II Deliverable D84.1, MACC-II Grant agreement n°283576. 13 pp. Eds: H.J. Eskes, V. Huijnen, A. Wagner, M. Schulz, E. Botek. info@copernicus-atmosphere.eu. July 2014.
- Henk, E., Antonakaki, T., A. Arola, A. Benedictow, A. Blechschmidt, E. Botek, S. Chabrillat, Y. Christophe, E. Cuevas, H. Flentje, A. Gaudel, J. Kapsomenakis, S. Kinne, B. Langerok, M. Razinger, A. Richter, M. Schulz, V. Thouret, M. Vrekoussis, A. Wagner, C. Zerefos. VAL scientific papers, including analyses of major events. MACC-II Deliverable D85.3, MACC-II Grant agreement n°283576. 5 pp. Eds: H.J. Eskes, V. Huijnen, A. Wagner, M. Schulz, E. Botek. info@copernicus-atmosphere.eu. July 2014.
- Integrated Carbon Observation System (Atmospheric Thematic Center), "ICOS Atmospheric Station Specifications", edited by O. Laurent, version 1, October 2014. List of contributors: Baum, S., Delmotte, M., Dvorska, A., Gerbig, C., Gomez-Pelaez, A., Grant, A., Hammer, S., Hanus, V., Hazan, L., Jordan, A., Laurent, O., Laurila, T., Lavric, J., Levin, I., Lindroth, A., Manning, A., Morgui, J.A., O'Doherty, S., Paris, J. D., Pavelka, M., Pilegaard, K., Plass-Duelmer, C., Ramonet, M., Reiter, I., Rivier, L., Schmidt, M., Steinbacher, M., Tarniewicz, J. Vermeulen, A., Wastine, B. A.
- Gomez-Pelaez, A.J., R. Ramos, V. Gomez-Trueba, R. Campo-Hernandez, E. Reyes-Sanchez: "Izaña Global GAW station greenhouse-gas measurement programme. Novelty and developments during October 2011-May 2013" in GAW report (No. 213) of the "17th WMO/IAEA Meeting on Carbon Dioxide, Other Greenhouse Gases, and Related Measurement Techniques (Beijing, China, June 10-14, 2013)", edited by P. Tans and C. Zellweger, World Meteorological Organization, 77-82, 2014 (download pdf).
- Terradellas, E., J. M. Baldasano, and E. Cuevas, (AEMET), Regional Center for Northern Africa, Middle East and Europe of the WMO Sand and Dust Storm Warning Advisory and Assessment System. Activity Report 2010-2012, Chair, Publications Board World Meteorological Organization (WMO), February, 2014.
- Terradellas, E., E. Cuevas y J. M. Baldasano (2014): Polvo mineral en la atmósfera, en 'Calendario Meteorológico 2014' pp. 263-271, AEMET, Madrid.

2013

- Antonakaki, T., A. Arola, A. Benedictow, A. Blechschmidt, I. Bouarar, S. Chabrillat, H. Clark, E. Cuevas, H. Flentje, A. Gaudel, J. Kapsomenakis, S. Kinne, B. Langerok, K. Lefever, M. Razinger, A. Richter, M. Schulz, V. Thouret, M. Vrekoussis, A. Wagner, C. Zerefos. Validation report of the MACC near-real time global atmospheric composition service System evolution and performance statistics Status up to 1 September 2013. MACC-II Deliverable D82.10, MACC-II Grant agreement n°283576. 85 pp. Eds: H.J. Eskes, V. Huijnen, A. Wagner, M. Schulz, K. Lefever. info@copernicus-atmosphere.eu. 9 December 2013.
- Antonakaki, T., A. Benedictow, A. Blechschmidt, I. Bouarar, S. Chabrillat, H. Clark, E. Cuevas, H. Flentje, A. Gaudel, J. Kapsomenakis, S. Kinne, K. Lefever, M. Razinger, A. Richter, M. Schulz, V. Thouret, M. Vrekoussis, A. Wagner, C. Zerefos. Validation report of the MACC near-real time global atmospheric composition service System evolution and performance statistics Status up to 1 March 2013. MACC-II Deliverable D82.8, MACC-II Grant agreement n°283576. 88

- pp. Eds: H.J. Eskes, V. Huijnen, A. Wagner, M. Schulz, K. Lefever. info@copernicus-atmosphere.eu. 21 June 2013.
- Antonakaki, T., A. Benedictow, A. Blechschmidt, I. Bouarar, S. Chabrillat, H. Clark, E. Cuevas, H. Flentje, A. Gaudel, J. Kapsomenakis, S. Kinne, B. Langerok, K. Lefever, M. Razinger, A. Richter, M. Schulz, V. Thouret, M. Vrekoussis, A. Wagner, C. Zerefos. Validation report of the MACC near-real time global atmospheric composition service System evolution and performance statistics Status up to 1 June 2013. MACC-II Deliverable D82.9, MACC-II Grant agreement n°283576. 84 pp. Eds: H.J. Eskes, V. Huijnen, A. Wagner, M. Schulz, K. Lefever. info@copernicus-atmosphere.eu. 2 October 2013.
- Benedictow, A., A. Blechschmidt, I. Bouarar, E. Cuevas, H. Clark, H. Flentje, A. Gaudel, J. Griesfeller, V. Huijnen, N. Huneus, L. Jones, J. Kapsomenakis, S. Kinne, K. Lefever, M. Razinger, A. Richter, M. Schulz, W. Thomas, V. Thouret, M. Vrekoussis, A. Wagner, C. Zerefos. Validation report of the MACC reanalysis of global atmospheric composition: Period 2003-2012. MACC-II Deliverable D83.5, MACC-II Grant agreement n°283576. 85 pp. Eds: D. Melas, E. Katragkou, M. Schulz, K. Lefever, V. Huijnen, and H. Eskes. info@copernicus-atmosphere.eu. 29 July 2013.
- Benedictow, A., A. Blechschmidt, I. Bouarar, S. Chabrillat, H. Clark, E. Cuevas, H. Flentje, V. Huijnen, J. Kapsomenakis, S. Kinne, K. Lefever, M. Razinger, A. Richter, M. Schulz, M. Vrekoussis, A. Wagner, C. Zerefos. Validation report of the MACC near-real time global atmospheric composition service System evolution and performance statistics Status up to 1 December 2012. MACC-II Deliverable D82.7, MACC-II Grant agreement n°283576. 74 pp. Eds: H.J. Eskes, V. Huijnen, A. Wagner, M. Schulz, S. Chabrillat. info@copernicus-atmosphere.eu. 8 March 2013.
- Benedictow, A., A. Blechschmidt, I. Bouarar, E. Cuevas, H. Clark, H. Flentje, J. Griesfeller, V. Huijnen, N. Huneus, L. Jones, J. Kapsomenakis, S. Kinne, K. Lefever, M. Razinger, A. Richter, M. Schulz, W. Thomas, V. Thouret, M. Vrekoussis, A. Wagner, C. Zerefos. Validation report of the MACC reanalysis of global atmospheric composition: Period 2003-2011. MACC-II Deliverable D83.4, MACC-II Grant agreement n°283576. 80 pp. Eds: D. Melas, E. Katragkou, M. Schulz, K. Lefever, V. Huijnen, and H. Eskes. info@copernicus-atmosphere.eu. 7 February 2013.
- Belmonte, J., E. Cuevas: Proyecto EOLO-PAT. Estudio de alergenos en Canarias. Resumen anual de datos 2012. Bellaterra: Proyecto EOLO-PAT, 2013.
- Belmonte, J., E. Cuevas: Proyecto EOLO-PAT. Estudio de alergenos en Canarias. Resumen anual de datos 2012. Bellaterra: Proyecto EOLO-PAT, 2013.
- Cuevas, E.,: Establishing a WMO Sand and Dust Storm Warning Advisory and Assessment System Regional Node for West Asia: Current Capabilities and Needs. WMO-No. 1121, Chair, Publications Board World Meteorological Organization (WMO), ISBN: ISBN 978-92-63-11121-0, December 2013.
- García, O., Congreso Anual NDACC-IRWG/TCCON 2013, AME, Bulletin July 2013, n°41, page 43, I.S.S.N: 1696-764X, 2013.
- Gómez Peláez, A.J., 17th WMO/IAEA Meeting on Carbon Dioxide, other Greenhouse Gases, and Related Measurement Techniques (GGMT-2013), AME, Bulletin July 2013, n°41, page 44, I.S.S.N: 1696-764X, 2013.
- Benedictow, A., A-M. Blechschmidt, I. Bouarar, H. Clark, E. Cuevas, H. Flentje, J. Griesfeller, V. Huijnen, N. Huneus, J. Kapsomenakis, S. Kinne, E. Katragkou, K. Lefever, M. Razinger, A. Richter, M. Schulz, W. Thomas, V. Thouret, M. Vrekoussis, A. Wagner, C. Zerefos. Validation report of the MACC near-real time global atmospheric composition service System evolution and performance statistics Status up to March 2012. MACC-II Deliverable D82.1, MACC-II Grant agreement n°283576. 75 pp. Eds: H.J. Eskes, V. Huijnen, A. Wagner, M. Schulz, K. Lefever. info@copernicus-atmosphere.eu. 12 June 2012.
- Benedictow, A., A. Blechschmidt, I. Bouarar, E. Cuevas, H. Clark, H. Flentje, J. Griesfeller, V. Huijnen, N. Huneus, L. Jones, J. Kapsomenakis, S. Kinne, K. Lefever, M. Razinger, A. Richter, M. Schulz, W. Thomas, V. Thouret, M. Vrekoussis, A. Wagner, C. Zerefos. Validation report of the MACC reanalysis of global atmospheric composition: Period 2003-2010. MACC-II Deliverable D83.1, MACC-II Grant agreement n°283576. 74 pp. Eds: D. Melas, E. Katragkou, M. Schulz, K. Lefever, V. Huijnen, and H. Eskes. info@copernicus-atmosphere.eu. June 2012.
- Benedictow, A., A. Blechschmidt, I. Bouarar, S. Chabrillat, H. Clark, E. Cuevas, H. Flentje, V. Huijnen, J. Kapsomenakis, S. Kinne, K. Lefever, M. Razinger, A. Richter, M. Schulz, M. Vrekoussis, A. Wagner, C. Zerefos. Validation report of the MACC near-real time global atmospheric composition service System evolution and performance statistics Status up to 1 June 2012. MACC-II Deliverable D82.1, MACC-II Grant agreement n°283576. 81 pp. Eds: H.J. Eskes, V. Huijnen, A. Wagner, M. Schulz, S. Chabrillat. info@copernicus-atmosphere.eu. 26 September 2012.
- Benedictow, A., A. Blechschmidt, I. Bouarar, S. Chabrillat, H. Clark, E. Cuevas, H. Flentje, V. Huijnen, J. Kapsomenakis, S. Kinne, K. Lefever, M. Razinger, A. Richter, M. Schulz, M. Vrekoussis, A. Wagner, C. Zerefos. Validation report of the MACC near-real time global atmospheric composition service System evolution and performance statistics Status up to 1 September 2012. MACC-II Deliverable D82.1, MACC-II Grant agreement n°283576. 79 pp. Eds: H.J. Eskes, V. Huijnen, A. Wagner, M. Schulz, S. Chabrillat. info@copernicus-atmosphere.eu. 10 December 2012.
- García, O., and Schneider, M.: Investigación del ciclo atmosférico del vapor de agua mediante Isotópos: el papel del proyecto MUSICA, AME, Boletín Julio 2012, n°37, pp 35-39, I.S.S.N: 1696-764X, 2012.
- García, O., Schneider, M., Hase, F., Blumenstock, T., Sepúlveda, E., and González, Y.: Monitorización de gases atmosféricos mediante espectrometría de infrarrojo por Transformada de Fourier, AME, Boletín Julio 2012, n°37, pp 34-35, I.S.S.N: 1696-764X, 2012.
- Gomez-Pelaez, A.J., R. Ramos, V. Gomez-Trueba, R. Campo-Hernandez, P. Novelli "In-situ carbon monoxide measurements at Izaña global GAW station: 2008-2011 time series, uncertainty analysis, and comparison with collocated weekly samples" in GAW report (No. 206) of the "16th WMO/IAEA Meeting on Carbon Dioxide, Other Greenhouse Gases, and Related Measurement Techniques (GGMT-2011)(Wellington, New Zealand, 25-28 October 2011)", edited by Gordon Brailsford, World Meteorological Organization, 91, 2012
- Gomez-Pelaez, A.J., R. Ramos, V. Gomez-Trueba, R. Campo-Hernandez, E. Dlugokencky, T. Conway "New improvements in the Izaña (Tenerife, Spain) global GAW station in-situ

greenhouse gases measurement program" in GAW report (No. 206) of the "16th WMO/IAEA Meeting on Carbon Dioxide, Other Greenhouse Gases, and Related Measurement Techniques (GGMT-2011) (Wellington, New Zealand, 25-28 October 2011)", edited by Gordon Brailsford, World Meteorological Organization, 76-81, 2012

Rodríguez, S., A. Alastuey, S. Alonso-Pérez, X. Querol, E. Cuevas, J. Abreu-Afonso, M. Viana, N. Pérez, M. Pandolfi, J. de la Rosa, Polvo Sahariano medio de transporte de contaminantes industriales Norteafricanos, AME, Boletín enero 2012, nº35, pp 18-22, I.S.S.N: 1696-764X, 2012.

27 PhD Theses

This section briefly describes the Doctoral Theses that have been supervised and co-supervised by researchers at IARC in the period 2012-2014.



Dr Sara Basart earned her PhD in Environmental Engineering (Degree of European Doctor) on 30 January 2012 with the top rating “Cum Laude” at the Technical University of Catalonia (UPC) with a Dissertation entitled “Mineral dust model evaluation through ground-based and satellite observations in Northern Africa, Europe and the Middle East”. The Supervisors were Dr Carlos Pérez (NASA Goddard Institute for Space Studies & Dept. of Applied Physics and Applied Mathematics, Columbia University) and Dr Emilio Cuevas (IARC; AEMET), with Prof. José María Baldasano (UPC-BSC) as Tutor.

The Doctoral Thesis Committee was constituted by Dr Slobodan Nickovic (then at WMO-Switzerland), Prof. Adolfo Comerón Tejero (UPC-Spain), Dr Gian Paolo Gobbi (CNR-Italy), Dr Nicolás Huneus (then at LSCE-France) and Dr Vassilis Amiridis (NOA-Greece).

More information on the Thesis defence [here](#).

Download the Thesis manuscript [here](#).



Dr Benjamin Torres successfully defended his PhD dissertation “Study on the Influence of Different Error sources on sky radiance Measurements and investment-derived aerosol products in the frame of AERONET” on 4 April 2012, at the University of Valladolid, obtaining the highest score, Apt “CUM LAUDE”.

This PhD was supervised by Dr Alberto J. Berjón (IARC; AEMET), and Dr Carlos Toledano, Atmospheric Optics Group (University of Valladolid). It also counts with the participation of Dr Oleg Dubovik, Laboratoire d’Optique atmosphérique (Université de Lille - CNRS), as international tutor.

More information on the Thesis defence [here](#).

Download the Thesis manuscript [here](#).



Dr Yenny Gonzalez-Ramos successfully defended her doctoral thesis entitled ‘Levels and origin of reactive gases and their relationship with aerosols in the proximity of emission sources and in the free troposphere at Tenerife’ on 19 July 2012 at the Izaña Atmospheric Research Center. The Thesis was supervised by Dr Sergio Rodríguez (IARC; AEMET) and Dr Juan Carlos Guerra (La Laguna University). The Doctoral Thesis Committee was composed by Prof. Venerando González (La Laguna University), Dr Luis Galindo (La Laguna University), Dr Inmaculada Menéndez (Las Palmas de Gran Canaria University), Dr Jesús de la Rosa (Huelva University) and Dr Teresa Moreno (CSIC, Barcelona). Dr Yenny González was honoured with the highest score (Apt “CUM LAUDE”).

More information on the Thesis defence [here](#).

Download the Thesis manuscript [here](#).



Dr Eliezer Sepúlveda successfully defended his doctoral thesis entitled “Ground-based Remote Sensing for the Detection of Greenhouse Gases by Fourier Transform InfraRed Spectrometry: Optimization of Retrieval Strategies and its Validation” on 25 April 2014, at the Izaña Atmospheric Observatory. The thesis was developed at the Izaña Atmospheric Research Center and was supervised by Dr Matthias Schneider (Karlsruhe Institute of Technology, KIT, Germany) and Dr Juan Carlos Guerra García (ULL). This thesis was supported by the FPU grant award by the Spanish Ministry of Education, Culture and Sport. This thesis was submitted by compendium of publications and has obtained the “International Mention”.

The Doctoral Thesis Committee was composed by: Dr Inocencio Rafael Martín Benenzuela (ULL), Dr Michel Grutter de La Mora (Universidad Nacional Autónoma de México) y Dr André Butz (KIT). The thesis obtained the maximum qualification “Sobresaliente, Cum Laude”.

More information on the Thesis defence [here](#).

Download the Thesis manuscript [here](#).

27.1 On-going PhD Theses

The theses that are currently in progress in the Izaña Atmospheric Research Center are:

1. Fernando Almansa: “Atmospheric aerosols detection by measuring the scattered solar radiation and emission in the thermal infrared spectral range”, University of Valladolid, Supervisors: Dr Emilio Cuevas (IARC-AEMET) and Prof. Dr Angel de Frutos (University of Valladolid)
2. Judit Carrillo: “Study on the Subtropical North Atlantic Troposphere Thermodynamic Structure”, University of La Laguna; Supervisors: Dr Juan Carlos Guerra (University of La Laguna) and Dr Emilio Cuevas (IARC-AEMET).
3. María Isabel García: “Sources and processes that contribute to the levels and physicochemical properties of anthropogenic aerosols observed in the free troposphere over the North Atlantic”, University of La Laguna; Supervisors: Dr Sergio Rodríguez, (IARC-AEMET), Andres Alastuey (IDAEA-CSIC), and Barend Van Drooge (IDAEA-CSIC).
4. Carmen Guirado Fuentes: “Characterization of total column aerosol properties in the subtropical region”, University of Valladolid, Supervisors: Dr Emilio Cuevas (IARC-AEMET) and Dr Ángel de Frutos (University of Valladolid).
5. Ruben Juárez-Prera: “Impact of air pollution on inflammation, oxidative stress and 1-year prognosis in patients admitted for acute ischemic heart disease”, University of La Laguna; Supervisors: Dr Alberto Domínguez-Rodríguez (University of La Laguna-Santa Cruz de Tenerife Clinical Hospital Clínico), Dr Pedro Abreu-González (University of La Laguna-Santa Cruz de Tenerife Clinical Hospital Clínico) and Dr Sergio Rodríguez (IARC-AEMET).
6. Niobe Peinado; “Validation of the IASI ozone retrievals with ground based measurements and other satellite data”, University of Valencia, Supervisors: Prof. Dr Ernesto López-Baeza (University of Valencia), Dr Xabier Calbet (EUMETSAT), and Dr Omaira García (IARC-AEMET).

28 Science Communication

The main tool of scientific communication of the IARC is, undoubtedly, its webpage (<http://izana.aemet.es>). Scientific information and articles are regularly posted. In this section, we give details of some of the science communication activities during the 2012-2014 period.

“The climate of Tenerife”, Museum of Nature and Man: Santa Cruz de Tenerife, Apr 26 2012

Rubén del Campo Hernández (IARC-AEMET) gave a presentation entitled: “The climate of Tenerife” at the Museum of Nature and Man (Santa Cruz de Tenerife), April 26th, 2012.

“Sustainable Tenerife”: Tenerife, May 8 2012

Dr Emilio Cuevas (IARC-AEMET) participated in a "Sustainable Tenerife" TV programme in TeideVisión Canal6 channel, La Orotava-Tenerife, May 8th, 2012.



XXXII Scientific Conference of the AME “Meteorology and Air Quality”: Alcobendas, 28-30 May 2012

Dr Emilio Cuevas (IARC-AEMET) participated in a roundtable discussion: "Meteorology and Air Quality" in the XXXII Scientific Conference of the Spanish Meteorological Association (AME), Alcobendas, Madrid, 28 to 30 May 2012.

Radio “Hoy por Hoy”: Tenerife, 19 Nov 2012

Dr Emilio Cuevas (IARC-AEMET) participated in “Cadena Ser”, “Hoy por Hoy” radio programme, 19th, November, 2012.



World Meteorological Day, CosmoCaixa Museum: Alcobendas, Madrid, 16-17 Mar 2013

Rubén del Campo Hernández (IARC-AEMET) provided workshops on "Clouds, Meteors and Meteorological Instrumentation" during the World Meteorological Day celebrations held at the "CosmoCaixa" Museum located in Alcobendas, Madrid on 16th-17th March 2013. The event was organized by the Spanish Meteorological Association (AME) and "La Caixa" Foundation.

"Observation of clouds and meteors", Cultural Week 2013: Cintruénigo, Navarra May 13 2013

Rubén del Campo Hernández (IARC-AEMET) gave a talk entitled: "Observation of clouds and meteors" during the Cultural Week 2013 dedicated to the environment, organized by IESO "La Paz", Cintruénigo (Navarra), May 13th, 2013.

"Tackling climate change” conference, Elder Museum of Science and Technology: Las Palmas de Gran Canaria, Jul 4 2013

Dr Emilio Cuevas (IARC-AEMET) participated in a roundtable discussion "Where are we going? Future Prospects”, at the conference " Tackling climate change” at the Elder Museum of Science and Technology, Las Palmas de Gran Canaria, July 4, 2013.

MACC-II/GMES-PURE Atmosphere Services User Workshop: Rutherford Appleton Laboratory, Harwell, UK, 11-12 Jun 2013

Rodríguez, S., Rodríguez, S., E. Cuevas, A. Domínguez-Rodríguez, Synergy of modelling and in-situ measurements for protecting human health from dust storms, MACC-II/GMES-PURE Atmosphere Services User Workshop, Rutherford Appleton Laboratory, Harwell, UK, 11 and 12 June, 2013.

New Weather Watch module, Museum of Science and the Cosmos: La Laguna, Tenerife, Mar 21 2014

The new Weather Watch module at the Museum of Science and the Cosmos, La Laguna, Tenerife, was inaugurated on March 21, 2014 during the celebration of the World Meteorological Day. Its implementation was made possible thanks to joint efforts of the staff of the Museum and the Izaña Atmospheric Research Center, and the cooperation of Vaisala, a company specializing in meteorological instrumentation, and the Teide Cable Car company.

Visitors can learn about the state of the atmosphere at different points of the island of Tenerife thanks to real time information provided by weather stations located at strategic locations of the island: Santa Cruz de Tenerife and Puerto de la Cruz (both located on the coast), San Cristobal de la Laguna (485 m), Izaña (2373 m) and Pico del Teide, at 3555 m, which is one of the highest weather stations in Europe. The application also allows, through a touch screen that can be operated easily and intuitively, to access the weather forecast for the next hours, observe the latest Meteosat satellite images or view real time images from webcams located at the Izaña Atmospheric Observatory, and know the most important meteorological ephemeris occurred in the Canaries.

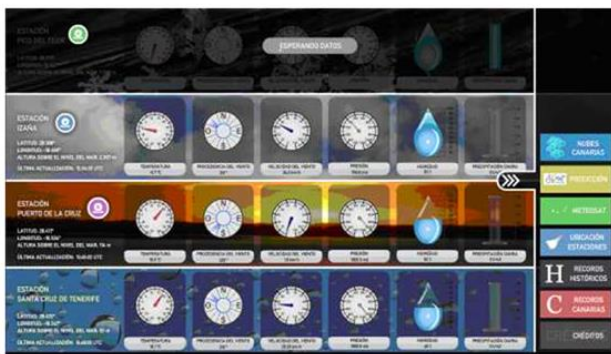

World Meteorological Day, Museum of Science and the Cosmos: La Laguna, Tenerife, Mar 21 2014

Rubén del Campo Hernández (IARC-AEMET) gave a talk entitled: "Impact of storms at Izaña Atmospheric Observatory. Weather summary of Winter 2013-2014"; during the celebration of the World Meteorological Day, held at the Museum of Science and the Cosmos, La Laguna Tenerife, on March 21, 2014.

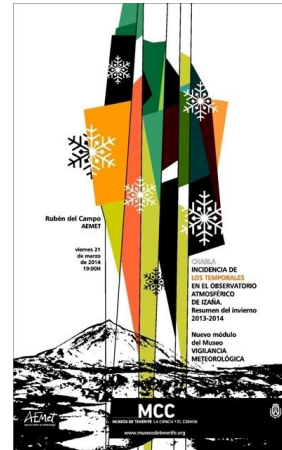

EUBREUNET workshop: Izaña, Tenerife, Mar 27 2014

Dr Emilio Cuevas (IARC-AEMET) presented the activities of the Izaña Atmospheric Research Center at the EUBREUNET workshop, Izaña, Tenerife, March 27th, 2014.

Guided tour of the Izaña Atmospheric Observatory: Apr 21 2014

Rubén del Campo Hernández (IARC-AEMET) gave a guided tour of the Izaña Atmospheric Observatory to students of the Technical Education and Environmental Control Training Module from PFIC "Los Gladiolos", April 21th, 2014.

Lecture "Izaña Atmospheric Observatory": PFIC "Los Gladiolos", Apr 28 2014

Rubén del Campo Hernández (IARC-AEMET) gave a lecture entitled: "Izaña Atmospheric Observatory", invited by the PFIC "Los Gladiolos" on April 28th, 2014.

Presentation Ceremony of the WMO/CBS Barcelona Dust Forecast Center (BDFC): AEMET, Madrid, Jun 10 2014

Dr Emilio Cuevas (IARC-AEMET) gave a presentation entitled: "Impact of Atmospheric Dust" during the SDS-WAS Regional Center for Northern Africa, Middle East and Europe, Presentation Ceremony of the WMO/CBS Barcelona Dust Forecast Center (BDFC), AEMET, Madrid, June 10th, 2014.

First Exhibition of Scientific and Professional Vocations in the Canary Islands: Tenerife, 16-17 Oct 2014



IARC participated with a stand and an oral presentation in the First Exhibition of Scientific and Professional Vocations in the Canary Islands, organized by the University of La Laguna, during 16-17 October, 2014. In this Fair a series of activities, such as exhibitions, workshops and talks, were made in order to raise awareness of science, technology, and innovation to young people of the island of Tenerife and to promote scientific and professional careers, especially among secondary school students.



The students who approached the stand could learn, firsthand, about the professional profiles of the staff of the IARC through explanations of IARC personnel (Omaira García, Silvia Alonso, Rubén del Campo Hernández, Javier López-Solano, Rocío López and Marina Jover) who voluntarily participated in the event. The various programmes and projects developed at IARC were described, and doubts and questions raised by the students and their teachers were answered. An overview of the activities carried out by AEMET, and specifically those developed at IARC, was given in the oral presentation: “García, O.E., E. Cuevas, R. Ramos, A. Gómez-Pélaez, A. Redondas, S. Rodríguez, P.M. Romero y JJ. Bustos, ¿Qué hacemos en el Centro de Investigación Atmosférica de Izaña?, I Feria de Vocaciones Científicas y Profesionales de Canarias, La Laguna (España), 16-17 Octubre, 2014”.

29 List of scientific projects

Table 29.1. List of scientific projects at IARC during 2012-2014.

Project Title	Duration	Funding Agency	Project Website	Principal Investigator/ Contact
Traceability of the Atmospheric total column ozone (ATMOZ)	2014-2017	EURAMET/EMRP	http://projects.pmodwrc.ch/atmoz/	PI (WRC): Dr Julian Gröbner PI (IARC-AEMET): Alberto Redondas
EGB-SVN EarthCare Ground Base-Spectrometer Validation Network (Pandonia network)	2014-2017	European Space Agency/LuftBlick	http://www.pandonia.net/	PI (ESA/LuftBlick): Dr Alexander Cede PI (IARC-AEMET): Alberto Redondas
Validation of IASI Level 2 products (VALIASI)	2013-2014 2015-2017	EUMETSAT	—	PI (IARC-AEMET): Dr Omaira García
COST ES-1207 EUBREWNET	2013-2016	EU COST Action	http://www.cost.eu/COST_Actions/essem/Actions/ES1207	PI (University of Manchester): Dr John Rimmer PI (IARC-AEMET): Alberto Redondas
WATER-GOA	2013-2016	Spanish Ministry of Economy and Competitiveness Spain National R&D /CGL2012-33576	—	PI (UVA): Dr Ángel M. de Frutos Baraja Contact (IARC-AEMET): Pedro Miguel Romero Campos
MUlti-platform remote Sensing of Isotopologues for investigating the Cycle of Atmospheric water (MUSICA)	2011-2016	European Research Council under FP7/2007-2013 No. 256961	http://www.imk-asf.kit.edu/english/musica.php	PI (IMK-ASF-KIT): Dr Matthias Schneider PI (IARC-AEMET): Dr Omaira García
Towards a Near Operational Validation of IASI level 2 trace gas products (NOVIA)	2013-2015	Spanish Ministry of Economy and Competitiveness	http://www.novia.aemet.es/	PI (IARC-AEMET): Dr Omaira García
Equipamiento para la Monitorización e Investigación de Gases de Efecto Invernadero y Aerosoles en la estación Global VAG (Vigilancia Atmosférica Global) de Izaña (Tenerife)	2013-2015	Spanish Ministry of Economy and Competitiveness No. AEDM13-3E-1773	—	PI (IARC-AEMET): Dr Emilio Cuevas
Integrated non_CO2 Greenhouse gas Observing System (InGOS)	2011-2015	Integrating Activity of European Union	http://www.ingos-infrastructure.eu/	PI (ECN): Dr Alex Vermeulen Contact (IARC-AEMET) Dr Omaira García

MACC and MACC-II— Monitoring Atmospheric Composition and Climate (Working Package; “Dust model validation”)	2011-2015	7th EU Framework Project (FP7) (FP7-SPACE-2011-1)	https://www.gmes-atmosphere.eu/	PI (ECMWF): Dr Vincent-Henry Peuch PI (IARC-AEMET): Dr Emilio Cuevas
Aerosols, Clouds, and Trace gases Research Infrastructure Network (ACTRIS)	2011-2015	EU FP7/2007-2013 No. 262254	http://www.actris.net/	PI (CNR-IMAA): Dr Gelsomina Pappalardo PI (IARC-AEMET): Dr Emilio Cuevas
CEOS intercalibración of ground based spectrometers and Lidars	2010-2015	European Space Agency through the Finnish Meteorological Institute ESRIN/Contract No. 22202/09/1EC	http://calvalportal.ceos.org/	PI (BIRA/IASB): Dr van Roozendaal PI (IARC-AEMET): Alberto Redondas
Composición, Fuentes y evolución multi-década del polvo y contaminantes particulados observados en la Capa de Air Sahariano (POLLINDUST)	2012-2014	Spain National R&D /CGL2011-26259	http://www.pollindust.aemet.es/	PI (IARC-AEMET): Dr Sergio Rodriguez
Network Of ground-based Remote Sensing observations (NORS)	2011-2014	EU FP7/2007-2013 No. 284421	http://nors.aeronomie.be/	PI (BIRA-IASB): Dr Martine De Mazière Contact (IARC-AEMET) Dr Omaira García
Impact of air pollution on inflammation, oxidative stress and 1-year prognosis in patients hospitalized for acute coronary syndrome (AIRACOS)	2011-2013	Health Institute Carlos III PI12/00092	—	PI (HUC): Alberto Domínguez-Rodríguez PI (IARC-AEMET): Dr Sergio Rodriguez
Retrieval of ISOTOPOlogue ratio from ground-based FTIR measurements, extension (RISOTO II)	2009-2013	National German Research Foundation (DFG)	—	PI (IMK-ASF-KIT): Dr Matthias Schneider
ICOS Spain. Implementation 2010 (AIC10-A-000474)	2010-2012	Spanish Ministry of Science and Innovation	—	PI (CEAM): Dr Millán Millán Muñoz PI (IARC-AEMET): Dr Emilio Cuevas
Spanish Network of Environmental DMA (REDMAAS)	2010-2012	Spain National R&D CGL2009-07128-E/CLI CGL2010-11095-E/CLI CGL2011-15008-E/CLI	http://www.redmaas.com/	PI (CIEMAT): Franciso Gómez. PI (IARC-AEMET): Dr Sergio Rodriguez
Formation and transport of atmospheric aerosol in a regional scale in Western Andalusia, Spain (AER-REG)	2008-2012	Department of Enterprise and Science, Government of Andalusia	—	PI (IARC-AEMET): Dr Sergio Rodriguez

Multidisciplinary Research Consortium on Gradual and Abrupt Climate Changes and their Impacts on the Environment (GRACCIE)	2008-2012	Ministerio de Educación y Ciencia del Programa CONSOLIDER INGENIO, CSD 2007-00067	http://www.graccie.eu/	Contact (IARC-AEMET): Dr Sergio Rodriguez
SDS-Africa	2007-2015	Spanish Agency for International Development Cooperation	—	PI (IARC-AEMET): Dr Emilio Cuevas
GAW-Sahara	2007-2015	Spanish Agency for International Development Cooperation	—	PI (IARC-AEMET): Alberto Redondas

Belgish Instituut Voor Ruimte-Aeronomie Institut D'Aéronomie Spatiale de Belgique (BIRA-IASB), Centro de Estudios Ambientales del Mediterráneo (CEAM), Centro de Investigaciones Energéticas, Medioambientales y Tecnológicas (CIEMAT), National Research Council of Italy-Institute of Methodologies for Environmental Analysis (CNR-IMAA), National German Research Foundation (DFG), European Centre for Medium-Range Weather Forecasts (ECMWF), Stichting Energieonderzoek Centrum Nederland (ECN), European Cooperation in Science and Technology (EU COST), European Organisation for the Exploitation of Meteorological Satellites (EUMETSAT), European Association of National Metrology Institutes-European Metrology Research Programme (EURAMET-EMRP), European Community's Seventh Framework Programme (FP7), Hospital Universitario de Canarias (HUC), Institut für Meteorologie und Klimaforschung - Atmosphärische Spurengase und Fernerkundung- Karlsruhe Institute of Technology (IMK-ASF-KIT), Research and Development (R&D), University of Valladolid (UVA), World Radiation Center (WRC).

30 List of major national and international networks and programmes

The Izaña Atmospheric Research Center participates in the following national and international networks and programmes:

ACTRIS	Aerosols, Clouds, and Trace gases Research InfraStructure Network
AERONET	AERosol RObotic NETwork
BSRN	Baseline Surface Radiation Network
CarbonTracker	NOAA/ESRL/GMD/ CarbonTracker Observational Network
CarbonTracker Europe	
EAN	European Aeroallergen Network
EARLINET	European Aerosol Research Lidar Network
E-GVAP	EUMETNET GPS water vapour Programme
EPN	EUREF Permanent Network
EUBREWNET	European Brewer Network
GAW	WMO Global Atmosphere Watch Programme
GCOS	Global Climate Observing System
GEOMON	Global Earth Observation and Monitoring of the Atmosphere
GLOBALVIEW-CO2	
GLOBALVIEW-CH4	
GLOBALVIEW-CO	
GLOBALVIEW-CO2C13	
GURME	WMO GAW Urban Research Meteorology and Environment project
Iberonesia Network Brewer scientific network associated to the RBCC-E	
ICOS	Integrated Carbon Observation System
MACC	Monitoring Atmospheric Composition and Climate
MPLNet	Micro-Pulse Lidar NETwork
NDACC	Network for the Detection of Atmospheric Composition Change
NOAA/ESRL/GMD CCGG Cooperative Air Sampling Network	
PHOTONS	PHOTométrie pour le Traitement Opérationnel de Normalisation Satellitaire
RBCC-E	Regional Brewer Calibration Center for Europe
REA	Red Española de Aerobiología
REDMAAS	Red Española de DMAs Ambientales
RIMA	Red Ibérica de Medida fotométrica de Aerosoles
SDS-WAS	WMO Sand and Dust Storm Warning, Advisory and Assessment System
SPALINET	Spanish and Portuguese Aerosol Lidar Network
TCCON	Total Carbon Column Observing Network
WCCAP	World Calibration Centre for Aerosol Physics

WDCGG	WMO GAW World Data Centre for Greenhouse Gases
WOUDC	World Ozone and Ultraviolet Data Center
WRC-WORCC	World Radiation Centre-World Optical Depth Research and Calibration Centre
WRC-WCC-UV	World Radiation Centre-World Calibration Center-Ultraviolet Section
WRDC	WMO World Radiation Data Centre

31 Staff

Research Staff				
Name	Affiliation	Position	Email	Personal Web Page
Almansa-Rodríguez, Antonio F.	AEMET/ UVA/ CIMEL	UV-Vis Photodiode Array Spectrometer development.	FernandoATsieltec.es	
Alonso-Pérez, Silvia (Dr) ^a	CSIC/ AEMET	African Air Intrusions Warning System		ResearchGate
Barreto-Velasco, África (Dr)	AEMET/ CIMEL	Lunar Cimel developments, LIDAR	africavbATgmail.com	
Berjón, Alberto (Dr)	AEMET	In situ Aerosols Programme	aberjonaATAemet.es	
Camino-González, Carlos ^a	AEMET	MACC Project		
Cuevas-Agulló, Emilio (Dr)	AEMET	Izaña Atmospheric Research Center, Director	ecuevasATAemet.es	ResearchGate Google Scholar
de Bustos-Seguella, Juan J.	AEMET	Meteorology Programme, Head. McIdas and Eumetcast Manager	jbustossATAemet.es	ResearchGate
García-Alvarez, Isabel	ULL/ AEMET	In situ Aerosols Programme	mig.aerosolATAemet.es	
García-Cabrera, Rosa Delia (Dr)	UVA/ AEMET	BSRN; Radiation Modelling	rgarciaATAemet.es	Google Scholar
García-Rodríguez, Omaira Elena (Dr)	AEMET	FTIR Programme	ogarciaATAemet.es	ResearchGate Google Scholar
Gómez-Peláez, Ángel J.	AEMET	Greenhouse Gases and Carbon Cycle Programme, Head	agomezpATAemet.es	ResearchGate Google Scholar
González-Ramos, Yenny (Dr)	SIELTEC/ IMK	FTIR Programme	ygonzalezramosATgmail.com	ResearchGate Google Scholar
Guirado-Fuentes, Carmen	UVA/ AEMET	ACTRIS Project	cguiradofATAemet.es	ResearchGate Google Scholar
Hernández-Pérez, Yballa ^a	AEMET	LIDAR-Ceilometer (aerosols)		
Hernández-Carrascal, M ^a Ángeles (Dr) ^a	AEMET	Cuerpo Superior Meteorólogos del Estado		
Hernández-Cruz, Bentorey	FGULL	Ozone and UV Programme	bhernandezATfg.ull.es	
Jover-Cornejo, Marina	SIELTEC	Reactive Gases Programme	marina.joverATsieltec.es	
Kühl, Sven Olav (Dr) ^a	AEMET	FTIR Programme		
León-Luís, Sergio Fabián (Dr) ^b	AEMET	Ozone and UV Programme	sleonlATAemet.es	
López-Solano, Javier (Dr)	AEMET	In situ Aerosols Programme	jlopezsATAemet.es	
Milford, Celia (Dr)	UHU/ AEMET	In situ Aerosols Programme, modelization	cmilfordATAemet.es	ResearchGate
Peris-Morell, Ana	FGULL	Ozone and UV Programme	anapmATfg.ull.es	
Redondas-Marrero, Alberto	AEMET	Ozone and UV Programme, Head	aredondasmATAemet.es	ResearchGate Google Scholar
Romero-Campos, Pedro M.	AEMET	Radiation and Water Vapour Programme, Head	promerocATAemet.es	
Rodríguez-Franco, Juan José	AEMET	RBCC-E; Ozone and UV Programme	jurodriguezATAemet.es	

Rodríguez-González, Sergio (Dr)	AEMET	In situ Aerosols Programme, Head	srodriguezgATAemet.es	ResearchGate Google Scholar
Rodríguez-Jiménez, Elba ^b	AEMET	Reactive Gases Programme	erodriguezjATAemet.es	
Sanromá Ramos, M Esther (Dr) ^b	AEMET	FTIR Programme	msanromarATAemet.es	
Sepúlveda-Hernández, Eliezer (Dr)	AEMET (FPU/ULL)	FTIR Programme	esepulvedahATAemet.es	ResearchGate
Sierra-Ramos, Marta ^a	AEMET	RBCC-E; Ozone and UV Programme		
Sosa Trujillo, Elisa ^b	AEMET	In situ Aerosols Programme	esosatATAemet.es	

^aNot at IARC at present, ^bJoined IARC in 2015

Technical Staff				
Name	Affiliation	Position	Email	Personal Web Page
Afonso-Gómez, Sergio	AEMET	Meteorological Observer /GAW technician	safonsogATAemet.es	
Bayo-Pérez, Concepción	AEMET	Meteorological Observer /GAW technician	cbayopATAemet.es	
Carreño-Corbella, Virgilio	AEMET	Meteorological Observer /GAW technician	vcarrenocATAemet.es	
Castro-Quintero, Néstor J.	AEMET	IT specialist	ncastroqATAemet.es	
Cruz-Martín, Antonio M.	AEMET	IT specialist	acruzmaATAemet.es	
del Campo-Hernández, Rubén	AEMET	Meteorological Observer /GAW technician	rcampohATAemet.es	LinkedIn Personal Web Page
de Ory-Ajamil, Fernando (Dr)	AEMET	Meteorological Observer /GAW technician	fdeoryaATAemet.es	
Hernández-Hernández, Cándida	AEMET	Meteorological Observer /GAW technician	chernandezhATAemet.es	
López-Fernández, Rocío	AEMET	IT specialist	rlopezfATAemet.es	
Ramos-López, Ramón	AEMET	Scientific instrumentation and infrastructures, Head	rramoslATAemet.es	
Reyes-Sánchez, Enrique	AEMET	Scientific instrumentation and infrastructures	ereyessATAemet.es	

Administration Staff				
Name	Affiliation	Position	Email	Personal Web Page
Bethencourt-Hernández, Julieta	AEMET	Administration Section, Head	cbethencourthATAemet.es	Personal web page
Damas-García, Marcos	AEMET	Driver	mdamasgATAemet.es	
Fernández-de Mesa y Aguilar, Caridad M. ^a	AEMET	Accounting officer		
Félix Santo Tomás-Castro ^b	AEMET	Accounting officer		
Sálamo-Hernández, Concepción	AEMET	Secretary	csalamohATAemet.es	

^aRetired, ^bJoined IARC in 2015

32 List of Acronyms

- ACE-FTS - Atmospheric Chemistry Experiment - Fourier Transform Spectrometry
- ACMAD - African Centre of Meteorological Application for Development
- ACS - Acute Coronary Syndrome
- ACSO - Absorption Cross Sections of Ozone
- ACTRIS - Aerosol Cloud and TRace gas InfraStructure
- ADF - aerosol radiative forcing
- AE - Angstrom Exponent
- AECID - Spanish Agency for International Development Cooperation
- AEMET - State Meteorological Agency
- AEROCOM - Aerosol Comparisons between Observations and Models
- AF - Radiative Forcing
- AMISOC - Atmospheric MinorSpecies relevant to the OzoneChemistry at both sides of the Subtropical jet
- ANN - Artificial Neuronal Networks
- AOD - Aerosol Optical Depth
- APS - Aerosol Polarimetry Sensor
- ATMOZ - Traceability for atmospheric total column ozone
- BBCH - Biologische Bundesanstalt, Bundessortenamt und Chemische Industrie
- BC - Black Carbon
- BDCN - National Climatological Data Base
- BDFC - Barcelona Dust Forecast Centre
- BSC-CNS - Barcelona Supercomputing Centre – National Supercomputing Centre
- BSRN - Baseline Surface Radiation Network
- BTO - Botanic Observatory
- CALIMA - Cloud, Aerosols and Ice Measurements in the Saharan Air Layer
- CARSNET - China Aerosol Remote Sensing NETwork
- CBL - Convective Boundary Layer
- CCD - Charge-coupled device
- CCGG - Carbon Cycle Greenhouse Gases group
- CCI - Climate Change Initiative
- CCLs - Central Calibration Laboratories
- CEAM - Centro de Estudios Ambientales del Mediterráneo
- CEOS - Committee on Earth Observation Satellites
- CIEMAT - Centro de Investigaciones Energéticas, Medioambientales y Tecnológicas
- CIMO - Commission for Instruments and Methods of Observations
- CINDI - Cabauw Intercomparison campaign Nitrogen Dioxide measuring Instrument
- CMA - China Meteorological Administration
- CRN – Centro radiométrico Nacional (Spain)
- CNR - National Research Council of Italy
- CNRS - Centre National de la Recherche Scientifique
- COST - European Cooperation in Science and Technology
- CPCs - Condensation Particle Counter
- CPT - Cold Point Tropopause
- CRDS - Cavity Ring-Down Spectroscopy
- CRR - Convective Rainfall Rate
- CSIC - Consejo Superior de Investigaciones Científicas
- CWT - Concentration Weighted Trajectory
- DBM - Daumont, Brion & Malicet
- DMN - Direction de la Météorologie Nationale
- DOAS - Differential Optical Absorption Spectroscopy
- DOD - Dust Optical Depth
- DREAM - Dust REgional Atmospheric Model
- DSCR - Digital Sky Colour Radiometer
- DT - Dynamical Tropopause
- DU - Dobson Unit
- DVB - Digital Video Broadcast
- EAN - European Aeroallergen Network
- ECC - Electrochemical concentration cell
- EC-MS - Environmental Canada-Meteorological Service of Canada
- ECMWF-IFS - European Centre for Medium-Range Weather Forecasts - Integrated Forecasting System
- EGVAP - EUMETNET GPS Water Vapour Programme
- EMA - Egyptian Meteorological Authority
- EMPA - Eidgenössische Materialprüfungs- und Forschungsanstalt
- EMRP - European Metrology Research Programme
- Eolo-PAT EOLO-Predicción Aerobiológica para Tenerife
- EPA - Environmental Protection Agency
- EPAU - Evaluación integral del impacto de las emisiones de partículas de los automóviles en la calidad del aire urbano
- ERA-Interim – ECMWF global atmospheric reanalysis from 1979
- ESA - European Space Agency
- ESA-CALVAL – European Space Agency Calibration and Validation project
- ESRL - Earth System Research Laboratory
- ETC - Extraterrestrial constant
- EUMETSAT - European Organisation for the Exploitation of Meteorological Satellites
- EURAMET - European Association of National Metrology Institutes
- FCS - Fraction Clear Sky
- FLEXTRA - FLEXible TRAjectories
- FMI - Finnish Meteorological Institute
- FNL - Final Analysis Data
- FOV - Field Of View
- FT - Free Troposphere
- FTIR - Fourier transform infrared spectroscopy

FTS - Fourier Transform Spectrometry
 FWHM - Full Width at Half Maximum
 GAW - Global Atmosphere Watch
 GAW -PFR - Global Atmosphere Watch - Precision Filter Radiometer
 GCOS - Global Climate Observing System
 GC-RGD - Gas Chromatography Reduction Gas Analyser
 GDAS - Global Data Assimilation System
 GEOS-5 -Goddard Earth Observing System model
 GFS - Global Forecast System
 GHG - Greenhouse Gas
 GLOBE - Global Learning and Observations to Benefit the Environment
 GLONASS - Global Navigation Satellite System
 GMD - Global Monitoring Division
 GMES - Global Monitoring for Environment and Security
 GNSS - Global Navigation Satellite System
 GOA - Atmospheric Optics Group
 GOA-UVA - University of Valladolid Atmospheric Optics Group
 GOME - Global Ozone Monitoring Experiment
 GPS - Global Positioning System
 GSR - Global Solar Radiation
 HARMONICS - Harmonised Assessment of Reliability of Modern Nuclear I&C Software
 HIRLAM - High Resolution Limited Area Model
 HUC - Hospital Universitario de Canarias
 HYSPLIT - Hybrid Single Particle Lagrangian Integrated Trajectory Model
 IAC - Instituto de Astrofísica de Canarias
 IAEA - International Atomic Energy Agency
 IAMAS - International Association of Meteorology and Atmospheric Sciences
 IARC - Izaña Atmospheric Research Center
 IASI -Infrared Atmospheric Sounding Interferometer
 ICIA - Instituto Canario de Investigaciones Agrarias
 ICOS - Integrated Carbon Observation System
 ICP-AES - Inductively Coupled Plasma Atomic Emission Spectroscopy
 ICP-MS - Inductively Coupled Plasma Mass Spectroscopy
 IDAEA - Institute of Environmental Assessment and Water Research
 IGACO - Integrated Global Atmospheric Observations
 IGN - Spanish National Geographic Institute
 ILAS - Improved Limb Atmospheric Spectrometer
 IMK-ASF - Institut für Meteorologie und Klimaforschung - Atmosphärische Spurengase und Fernerkundung
 INM - Institut National de la Météorologie
 INSTAAR - Institute of Arctic and Alpine Research
 INTA - Instituto Nacional de Técnica Aeroespacial
 IO3C - International Ozone Commission
 IR - Infrared
 IUP - Institut für Umweltphysik / Institute of Environmental Physics
 IZO - Izaña Atmospheric Observatory
 KIT - Karlsruhe Institute of Technology
 LABEC - Laboratorio di Tecniche Nucleari per i Beni Culturali
 LAP - Laboratori d'Anàlisis Palinològiques
 LIDAR - Laser Imaging Detection and Ranging
 LOA - Laboratoire d'Optique Atmosphérique
 LSCE - Laboratoire des Sciences du Climat et de l'Environnement
 MAAP - Multi Angle Absorption Photometer
 MARS - Meteorological Archival and Retrieval System
 MAXDOAS - Multi Axis Differential Optical Absorption Spectroscopy
 MBL - Marine Boundary Layer
 MCAR - Mean Concentrations At Receptor
 McIDAS - Man Computer Interactive Data Access System
 MetUN - Met Office Unified Model
 MFRSR - Multi Filter Rotating Shadow-Band Radiometer
 MGA - Modified Geometrical Approach
 MIPAS - Michelson Interferometer for Passive Atmospheric Sounding
 MIR - Middle Infrared
 MISR - Multi-angle Imaging SpectroRadiometer
 MLO - Mauna Loa Observatory
 MM5 - Mesoscale Model
 MODIS - Moderate Resolution Imaging Spectroradiometer
 MPL - Micro Pulse Lidar
 MSG - Meteosat Second Generation
 MUSICA - MUlti-platform remote Sensing of Isotopologues for investigating the Cycle of Atmospheric water
 NA-ME-E - The Regional Centre for Northern Africa, Middle East and Europe
 NAO - North Atlantic Oscillation
 NAS - Network-Attached Storage
 NASA - National Aeronautics and Space Administration
 NASA MPLNET - The NASA Micro Pulse Lidar Network
 NCEP - National Centers for Environmental Prediction
 NDIR - Non Dispersive
 NEMS - NOAA Environmental Modeling System
 NGAC - NEMS GFS Aerosol Component
 NILU - Norwegian Institute for Air Research
 NIR - Near Infrared
 NIST - National Institute for Standards and Technology
 NMHSS - National Meteorological and Hydrological Services
 NMMB - Nonhydrostatic Multiscale Model on the B-grid
 NMME - North American Multi-Model Ensemble

NOA - National Observatory of Athens
 NOAA - National Oceanic and Atmospheric Administration
 NORS - Demonstration Network Of ground-based Remote Sensing Observations in support of the Copernicus Atmospheric Service
 NOVIA - Towards a Near Operational Validation of IASI level 2 trace gas products
 NPF - New Particle Formation
 ODSs - Ozone Depleting Substances
 OMI - Ozone Monitoring Instrument
 ONM - Office National de la Météorologie
 OSC - ozone slant column
 OT - Ozone Tropopause
 PAR - Photosynthetic Active Radiation
 PARTILAB - Particles Laboratory
 PFR - Precision Filter Radiometer
 PI - Principal Investigator
 PIXE - Particle-Induced X ray Emission
 PLASMA - Photomètre Léger Aéroporté pour la Surveillance des Masses d'Air
 PM - Particle Matter
 PMOD - Physikalisch-Meteorologisches Observatorium Davos
 POLLINDUST - Studying the dust and pollutants in the Saharan Air Layer
 PSR - Precision Solar Spectroradiometer
 PTB - Physikalisch-Technische Bundesanstalt
 PV - Potential Vorticity
 PWV - Precipitable Water Vapour
 QA - Quality Assurance
 QASUME - Quality Assurance of Spectral Ultraviolet Measurements
 QC - Quality Control
 R&D - Research and Development
 RBCC-E - Regional Brewer Calibration Center for Europe
 REA - Red Española de Aerobiología
 REDMAAS - Red Española de DMAs Ambientales
 RGB - composite - Red Green Blue composite
 RH - Relative Humidity
 RMSE - Root Mean Square Error
 ROLO - Robotic Lunar Observatory model
 RSMC-ASDF - Regional Specialized Meteorological Centre with activity specialization on Atmospheric Sand and Dust Forecast
 RTM - Radiative Transfer Model
 SAF - Satellite Application Facilities
 SAG - Scientific Advisory Group
 SAL - Saharan Air Layer
 SALAM - Air Layer Air Mass characterization
 SAUNA - Sodankylä Total Column Ozone Intercomparison
 SCIAMACHY - Scanning Imaging Absorption Spectrometer for Atmospheric Chartography
 SCO - Santa Cruz Observatory
 SD - Sunshine Duration
 SDM - Standard Delivery Mode
 SDR - Shortwave downward radiation
 SDS - Sand and Dust Storm
 SDS-WAS - Sand and Dust Storm Warning Advisory and Assessment System
 SEAIC - Sociedad Española de Aerobiología e Inmunología Clínica
 SeaWIFS - Sea-Viewing Wide Field-of-View Sensor
 SEM - standard error of the mean
 SMN - Argentinian Meteorological Service
 SMPS - Scanning mobility particle sizer
 SOL - Significant Obstructive Lesions
 SONA - Sistema de Observación de Nubes Automático
 SOP - Standard Operating Procedure
 SPARC - Stratosphere-troposphere Processes And their Role in Climate
 SPC - Science Pump Corporation
 SSDM - Server Meteorological Data System
 STJ - Subtropical Jet Stream
 STS - Sky Temperature Sensor
 STT - stratosphere-to-troposphere
 SYNOP - Surface Synoptic Observation
 SZA - Solar Zenith Angle
 TNA - Trans National Access
 TOC - Total Ozone Column
 TPO - Teide Peak Observatory
 TSP - Total Suspended Particles
 TT - Thermal Tropopause
 UAB - Universidad Autónoma de Barcelona
 UFPs - Ultrafine Particles
 ULL - University of La Laguna
 UNEP - United Nations Environment Programme
 UN-GESAMP - United Nations - Group of Experts on the Scientific Aspects of Marine Environmental Protection
 UPC - Universitat Politècnica de Catalunya
 UPS - Uninterruptible Power Supply
 USGS - U.S. Geological Survey
 UTC - Coordinated Universal Time
 UTLS - Upper Troposphere Lower Stratosphere
 UV - Ultraviolet
 UVA - University of Valladolid
 VALIASI - Validation of the EUMETSAT products of atmospheric trace gases observed from IASI using ground-based Fourier Transform Infrared spectrometry
 VIS - Visible

VMR - Volume Mixing Ratio
WCC - World Calibration Center
WDCGG - World Data Centre for Greenhouse Gases
WIGOS - Integrated Global Observing System
WMO - World Meteorological Organization
WORCC - World Optical Depth Research and Calibration
Center
WOUDC - World Ozone and Ultraviolet Data Center
WRC - World Radiation Center
WS-CRDS - Wavelength-Scanned Cavity Ring-Down
Spectroscopy
XS - Cross Section
ZHD - Zenith Hydrostatic Delay
ZTD - Zenith Total Delay

33 Acknowledgements

This report was prepared with contributions, direct or indirect, of all who are part of the Izaña Atmospheric Research Centre. This report, therefore, is an express recognition of work done by each and every one of the people working in the IARC.

We are grateful for the decisive support to the IARC and its activities of the President of AEMET (Miguel Ángel López) and the Director of Planning, Strategy and Business Development (DPEDC- AEMET), Carmen Rus.

We recognize the World Meteorological Organization for establishing and coordinating the GAW programme, the core programme of the IARC activities, and thank the WMO for its continuing support.

We express our gratitude to all those institutions, addressed in this report, which work closely with the IARC with measurement programmes at Izaña, by means of scientific collaborations, or through international cooperation projects.

Our colleagues of the External Relations Division of AEMET, especially Julio González Breña, Paco Espejo and Manolo Palomares, have greatly facilitated the IARC international cooperation and projection. Dr Yolanda Luna, AEMET Department of Development and Applications, Head, has helped us in the administration of R & D projects. AEMET Department of Infrastructure and Systems, Head, Maria Lopez-Bartolomé, has always given us support in all matters relating to infrastructure and observation networks. We thank our colleagues from the Department of Administration for all their help with administrative procedures without which it would not be possible to maintain the IARC.

We thank Miguel Angel Garcia-Couto, AEMET Documentation Service, Head, for his support and good ideas in the final publication of this report.

Last but not least, we want to thank the work of the DPEDC secretary, Yolanda Berlanga, "our link to Madrid", for all her help and support.

Back cover photograph: Izaña Atmospheric Observatory
(Photo: Rubén del Campo Hernández)

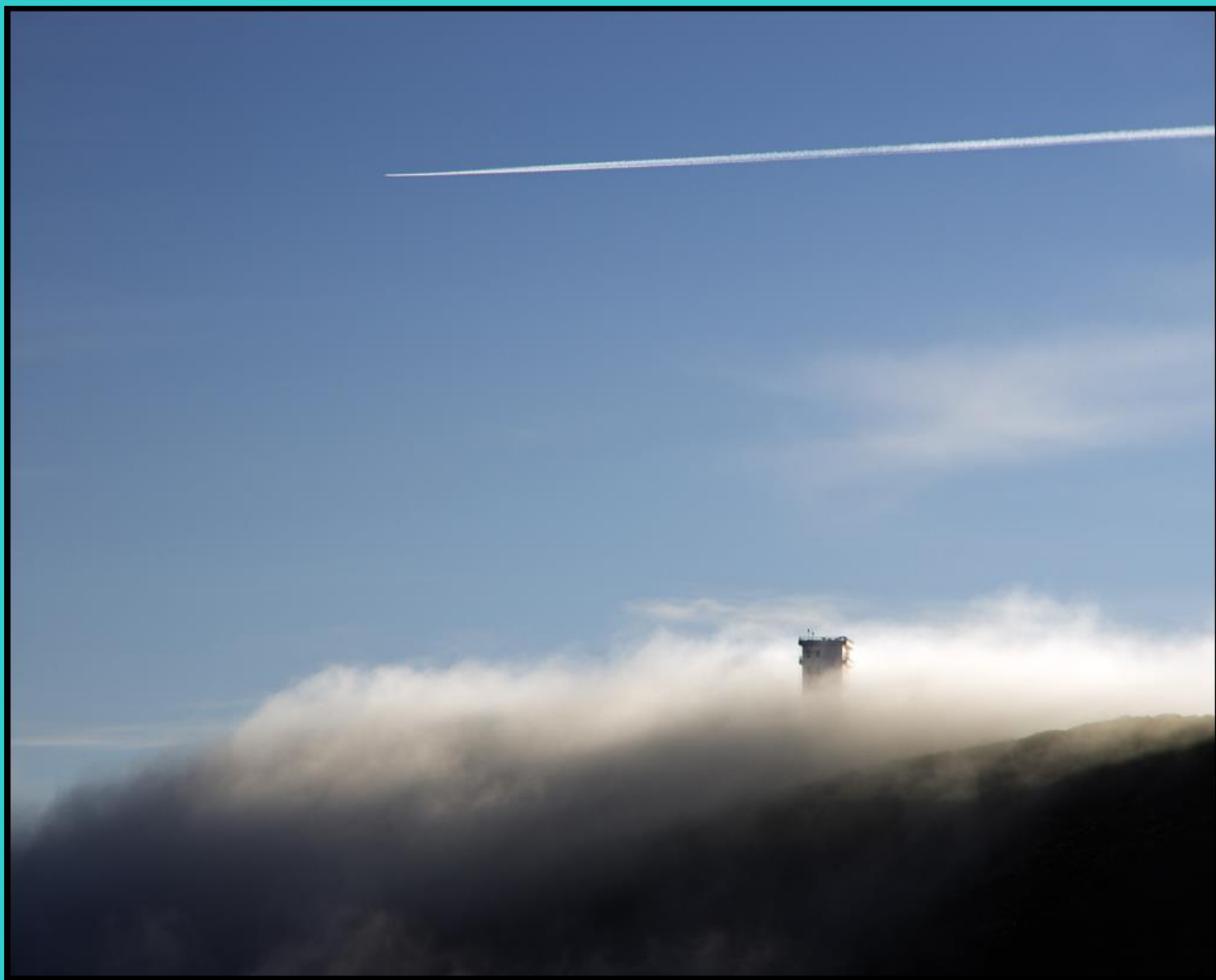

For more information, please contact:
Izaña Atmospheric Research Center
Calle La Marina, 20
Santa Cruz de Tenerife
Tenerife, 38071, Spain
<http://izana.aemet.es>