

Summer 2002

In the Shadow of the Fleet: The Development of American Submarines Between the World Wars

Stephen J. Brady
Old Dominion University

Follow this and additional works at: https://digitalcommons.odu.edu/history_etds



Part of the [Military History Commons](#), and the [United States History Commons](#)

Recommended Citation

Brady, Stephen J.. "In the Shadow of the Fleet: The Development of American Submarines Between the World Wars" (2002). Master of Arts (MA), thesis, History, Old Dominion University, DOI: 10.25777/he9b-c895
https://digitalcommons.odu.edu/history_etds/17

This Thesis is brought to you for free and open access by the History at ODU Digital Commons. It has been accepted for inclusion in History Theses & Dissertations by an authorized administrator of ODU Digital Commons. For more information, please contact digitalcommons@odu.edu.

IN THE SHADOW OF THE FLEET: THE DEVELOPMENT OF AMERICAN
SUBMARINES BETWEEN THE WORLD WARS

by

Stephen J. Brady
B.S. December 1979, University of New Orleans

A Thesis Submitted to the Faculty of Old Dominion University
in Partial Fulfillment of the Requirement for the Degree of

MASTER OF ARTS

HISTORY

OLD DOMINION UNIVERSITY
August 2002

Approved by:

Carl Boyd (Director)

Craig M. Cameron (Member)

Annette Finley-Croswhite (Member)

UMI Number: 1411389

Copyright 2002 by
Brady, Stephen James

All rights reserved.

UMI[®]

UMI Microform 1411389

Copyright 2003 by ProQuest Information and Learning Company.
All rights reserved. This microform edition is protected against
unauthorized copying under Title 17, United States Code.

ProQuest Information and Learning Company
300 North Zeeb Road
P.O. Box 1346
Ann Arbor, MI 48106-1346

ABSTRACT

IN THE SHADOW OF THE FLEET: THE DEVELOPMENT OF AMERICAN SUBMARINES BETWEEN THE WORLD WARS

Stephen J. Brady
Old Dominion University, 2002
Director: Dr. Carl Boyd

At the close of the First World War, American submarines compared most unfavorably with those of Germany and Great Britain. German submarines sank over 5000 ships, while the British submarine campaign, much less ambitious by design, was still credited with sinking 54 warships and 274 other vessels. Standing in stark contrast, American submarines did not sink a single ship. However, by the end of the Second World War, American submarines would sink over 1300 Japanese merchantmen and warships. This ultimate success was hard won, for attempts to modernize American submarine designs between the wars were continually stifled by advocates of the U.S. Navy's battleship-dominated fleet doctrine, particularly in the 1920s. The fractious organization of the Navy Department also retarded submarine development. Battleships, and to a lesser extent naval air power, developed under more favorable conditions because of their perceived importance to the fleet. Submarine growth depended on supporters with shared interests at lower organizational levels and on the common will of submarine line officers. It took many years for it to evolve, but a council of submarine officers and engineers known as the Submarine Officers Conference ultimately exerted a decisive influence on submarine development. The major technological obstacle to submarine growth was the development of reliable diesel engines, and an analysis of diesel technology is a cornerstone of this study. Not perfected until 1941, these designs

received a crucial boost from the concurrent demand for similar engines in the American railroad locomotive market. Without this commercial market, the submarine engines would have developed much more slowly, and the staggering casualties experienced by submarine engines in the late 1930s would not likely have been resolved until much later. The American choice of all-electric propulsion for submarines, unique among major navies of the Second World War, is also explored. Four major factors that shaped American submarine development are identified. They are naval doctrine, technology, organizational dynamics, and the free market. These causes are analyzed and evaluated as a means of explaining this unique case in the evolution of military technology.

© 2002 Stephen J. Brady. All rights reserved.

ACKNOWLEDGEMENTS

I would like to thank Dr. Carl Boyd, my advisor throughout this project, for his direction, insight, and patience. I would also like to thank Dr. Craig M. Cameron who was instrumental in advising me in the early stages of this endeavor, and Dr. Annette Finley-Croswhite, who provided a fresh perspective on the study. None of this would have been possible without the assistance of my wife, Katherine Wilson. Her critical reviews of my work and her resolute encouragement were indispensable.

TABLE OF CONTENTS

Chapter	Page
I. INTRODUCTION	1
II. THE REAL FLEET BOAT	9
III. ORGANIZATIONAL RIVALRIES	19
IV. THE U-BOAT CONTROVERSY	27
V. CRUISERS AND THE PACIFIC MISSION	35
VI. "PERFECTLY RELIABLE" ENGINES	44
TECHNOLOGICAL LIMITS	44
THE LINE OFFICERS REBEL	51
VII. ELECTRIC SHIPS	58
VIII. THE RAILROAD CONNECTION	71
IX. THE RISE OF THE SUBMARINE OFFICERS CONFERENCE	79
X. PROPULSION PLANT TRADEOFFS AND EMERGENCE OF THE 1500-TON DESIGN	88
XI. A DESIGN SOLIDIFIES	107
XII. CONCLUSION	118
BIBLIOGRAPHY	128
APPENDICES	
A. AMERICAN SUBMARINE CHARACTERISTICS	133
B. A BRIEF COMPARISON OF GERMAN AND AMERICAN SUBMARINE DESIGNS OF THE SECOND WORLD WAR	138
VITA	141

LIST OF TABLES

Table	Page
1. Engineering Tradeoffs of Electric Drive Versus Composite Drive.....	100

LIST OF FIGURES

Figure	Page
1. Interwar Navy Department Organization.....	20
2. Schematic Diagrams of Propulsion Plant Arrangements.....	59

ABBREVIATIONS

ASNE	American Society of Naval Engineers
ASW	Anti-Submarine Warfare
BUAIR	Bureau of Aeronautics
BUC&R	Bureau of Construction and Repair
BUENG	Bureau of Engineering
Bu-MAN	MAN engines reverse engineered by BUENG
BUNAV	Bureau of Navigation
BUORD	Bureau of Ordnance
BUSHIPS	Bureau of Ships
CNO	Chief of Naval Operations
DDD	Diesel-Direct Drive
DED	Diesel-Electric Drive
DERD	Diesel-Electric-Reduction Gear Drive
DRD	Diesel-Reduction Gear Drive
EB	Electric Boat Company
EDO	Engineering Duty Only
EMC	Electro-Motive Corporation
FY	Fiscal Year
GM	General Motors
HOR	Hooven-Owens-Rentschler
LST	Landing Ship, Tank

ABBREVIATIONS—Continued

MAN	<i>Maschinenfabrik Augsburg-Nürnberg</i>
MIC	Military-Industrial Complex
MIT	Massachusetts Institute of Technology
Nelseco	New London Ship and Engine Company
NIRA	National Industrial Recovery Act
NWC	Naval War College
NYNY	New York Naval Shipyard
OP	Opposed Piston
SNAME	Society of Naval Architects and Marine Engineers
SOC	Submarine Officers Conference
WPB	War Production Board

CHAPTER I

INTRODUCTION

Between 1918 and 1945 the U.S. Navy's submarines were transformed from minor auxiliaries into one of the most potent weapons in the American arsenal. This study is an analysis of the growth of that capability between the world wars. Four major influences on development are addressed: naval doctrine, technological capability, organizational dynamics, and commercial markets. Other external influences, such as economic and political conditions, are also important within the framework of this study. These external factors can be considered the environment in which submarines developed, whereas the four major influences mentioned above represent the forces shaping the direction of that development.

The approach used in this study is based in part on the review of a variety of histories of technology, in both military and civilian applications. Traditional explanations for technological growth are rooted in determinism, the belief that the emergence of new technology drives the course of history, almost independent of human will. In such views, the automobile and the airplane were near certain consequences of the internal combustion engine, just as the railroad locomotive was precipitated by the invention of the steam engine a century earlier. Military applications of technology could be expected to follow an expedited version of the same pattern, since a technical edge during war can be decisive. Determinism may be useful for broad generalizations, but, in reality, a more complex set of causes typically lies behind technological growth.

The format for this thesis follows current style requirements of Kate L. Turabian, *A Manual for Writers of Term Papers, Theses, and Dissertations*, 6th ed. (Chicago: The University of Chicago Press, 1996).

Some twentieth-century assessments have shown how cultural variables and other non-technical factors have been important to the growth of technology. Thomas Hughes's *Networks of Power*, a comparative analysis of the development of electrical power distribution systems in Chicago, London, and Berlin, is a typical example. Hughes was one of the first to demonstrate that technological systems are actually cultural artifacts, each a reflection of the unique economic, political, and cultural environment in which it arises.¹

The influence of organizational dynamics has also had a potent effect on technological growth. Beginning in the twentieth century, in particular, the increasing complexity of modern society required increased interaction among ever-more-intricate organizations. The search for more sophisticated weapons led to unprecedented collaboration among armed services, industrial concerns and their research laboratories, and technical experts in academia. This ultimately led to formation of the modern military-industrial-complex (MIC), early examples of which include the Manhattan Project and the German guided missile program at Peenemünde. The integration of large dissimilar organizations inevitably led to fault lines between bureaucratic cultures that shaped the course of development. Though the MIC was not his topic, historian and social scientist Daniel R. Headrick summarizes this point nicely: "While it often seems that technology influences the course of history . . . it is in fact organizations that control the interactions between 'technology' and 'man' and, through their interactions with each other, make history."²

¹ Thomas Hughes, *Networks of Power: Electrification in Western Society, 1880-1930* (Baltimore: John Hopkins University Press, 1983).

² Daniel R. Headrick, *The Invisible Weapon: Telecommunications and International Politics, 1851-*

Competition among services for military jurisdiction and, hence, funding and power have often had a noticeable impact on development. Budgets are a zero-sum proposition, and any change that does not increase the budgets of all will almost always result in conflict. Science and technology historian Timothy Moy demonstrates how the growth of air power between the world wars was partially driven by the struggle between the U.S. Army and U.S. Navy over ownership of the strategic bombing mission.³

Intra-service competition is a much more important factor in this study than competition between services. It has long been recognized that the U.S. Navy is divided into three main camps that vie for power: the patrons of surface ships, submarines, and air power. An overlay on these factions is the rivalry between line officers and naval engineers, which naval historian William McBride traces in *Technological Growth and the U.S. Navy, 1865-1945*.⁴ One contribution made by the present study is to explore how this line officer-engineer rivalry affected the growth of American submarines. It will be seen that this competition for power revolved in large part around the perceived quality of German submarines of the First World War. American submarine commanders were convinced that German submarines were vastly superior to their own, and U.S. Navy engineers were just as certain that the U-boats were critically flawed. This rivalry played out in the context of the complex and often adversarial structure of the Navy Department, which tended to exacerbate tension between the parties. This study shows that the formation of the Submarine Officers Conference provided the

1945 (New York: Oxford University Press, 1991), 9.

³ Timothy Moy, *War Machines: Transforming Technologies in the U.S. Military, 1920-1940* (College Station: Texas A&M University Press, 2001).

⁴ William M. McBride, *Technological Change and the United States Navy, 1865-1945* (Baltimore: Johns Hopkins University Press, 2000).

organizational solution to the dilemma posed by the line officer-engineer rivalry. This group of submarine officers and engineers forged an alliance that cut across organizational lines and advanced the collective interests of most submarine advocates in the Navy Department.

McBride also demonstrates how powerful doctrine can be in controlling weapon growth. Command of the sea via the “battleship paradigm,” as he terms it, dominated naval thinking from ship-of-the-line sailing days, until naval air power dramatically proved its obsolescence during the Second World War. The perceived importance of the battleship not only limited the funding available for submarine development, it also heavily influenced the types of submarines designed and built, particularly in the 1920s. This study shows that the power of battleship doctrine was exemplified by the navy’s plans to build dangerous steam-powered submarines, abandoned only after the sustained lobbying of submariners, the abject failure of similar craft in Great Britain’s Royal Navy, and drastic reductions in naval funding after the First World War.

There are also external elements to consider in any evaluation such as this. The health of a nation’s economy, the influence of political elites, and a state’s disposition toward the maintenance of armed forces and their weapons are all important. The free market is another external factor that has exerted considerable influence in some cases, particularly before the evolution of the MIC after the Second World War. The concurrent demand of submarines and railroad locomotives for the same kind of diesel engine will be shown to affect submarine development critically.

To evaluate this phenomenon, this study reviews the relationship between private diesel engine manufacturers and the U.S. Navy bureaus, in part from the outlook of

business historians. Chief among the works consulted is Albert J. Churella's *From Steam to Diesel: Managerial Customs and Organizational Capabilities in the Twentieth-Century American Locomotive Industry*.⁵ Churella analyzes the transition of the American railroad industry from steam- to diesel-powered locomotives in the twentieth century, and in so doing, addresses the connection between the naval and commercial markets. Thomas George Marx's dissertation, entitled "The Diesel – Electric Locomotive Industry: A Study in Market Failures," provides relevant insight into the railroad locomotive industry.⁶ The observations of business historian Alfred D. Chandler were also useful for understanding the environment in which corporations operated in this era.⁷

Finally, there is the role of technology itself. Histories of naval technology are typically written in one of two styles, that of either the generalist or the specialist. McBride and Moy's works discussed above are examples of general histories that were consulted in preparation of this study. There are also three major works, written mostly in the style of the specialist, that address American submarine development during the period, and they constitute the established literature on this topic. John D. Alden's *The Fleet Submarine in the U.S. Navy: A Design and Construction History*, provides an assessment of the growth of submarine technology, primarily from the perspective of

⁵ Albert J. Churella, *From Steam to Diesel: Managerial Customs and Organizational Capabilities in the Twentieth-Century American Locomotive Industry* (Princeton, NJ: Princeton University Press, 1998).

⁶ Thomas George Marx, "The Diesel-Electric Locomotive Industry: A Study in Market Failures" (Ph. D. diss., University of Pennsylvania, 1973).

⁷ Alfred D. Chandler, *Scale and Scope: The Dynamics of Industrial Capitalism* (Cambridge, MA: Harvard University Press, 1990).

U.S. Navy bureau engineers.⁸ In *U.S. Submarines through 1945: An Illustrated Design History*, Norman Friedman provides the most comprehensive technological history of American submarines, filling in many details and expanding considerably on Alden's work (Alden reviewed and contributed to Friedman's manuscript).⁹ Friedman drew extensively upon Navy Department primary sources to produce what is probably the most comprehensive technological history of any nation's submarines. Whereas Alden and Friedman are primarily concerned with the growth of technology itself, Gary E. Weir's *Building American Submarines, 1914-1940*, provides a considerable amount of technical detail, but also more attention to the issues addressed by generalists, such as organizational dynamics and doctrine.¹⁰

This study is written primarily from the perspective of the generalist; however, the work also contains a detailed discussion of main propulsion systems, which were selected for scrutiny for several reasons. First, the growth of the diesel engine was the most important technological influence on submarines between the world wars. The examination of main propulsion systems also provides the reader a glimpse into the decision-making process of navy engineers, while at the same time illustrating how the ultimate selection of diesel-electric drive reflected the Americans' unique cultural circumstances, not just a dry solution to an engineering problem.

A variety of primary and secondary sources were consulted during preparation of this study. In addition to the materials discussed above, the study draws from three major

⁸ John D. Alden, *The Fleet Submarine in the U.S. Navy: A Design and Construction History* (Annapolis: Naval Institute Press, 1979).

⁹ Norman Friedman, *U.S. Submarines through 1945: An Illustrated Design History* (Annapolis: Naval Institute Press, 1995).

¹⁰ Gary E. Weir, *Building American Submarines, 1914-1940* (Washington D.C.: Department of the Navy, Naval Historical Center, 1991).

primary sources. The most important is the microfilm collection entitled *Hearings before the General Board of the Navy, 1917-1950*, a fifteen-reel collection that contains over ten thousand pages of testimony taken before the General Board. This material is important to this study since the primary charter of the General Board during this period was to establish the characteristics of all U.S. Navy ships to be recommended to Congress. The other major primary sources used were Record Group 19 and Record Group 80 of the National Archives in Washington, D.C. Record Group 19 was consulted for records of the U.S. Navy's technical bureaus and Record Group 80 was reviewed for relevant correspondence of the Secretary of the Navy, primarily that of the Chief of Naval Operations and the General Board. A comprehensive review was also conducted of naval and technical periodicals published during the interwar period. This review included the journals and proceedings of the Society of Naval Architects and Marine Engineers, the United States Naval Institute, the American Society of Naval Engineers, the Institution of Naval Architects (Great Britain), and the Naval War College.

Other authors who have published on this topic have used the General Board's hearings, but this study delves into them more heavily in order to explore the navy's organizational dynamics, to evaluate the effect of battleship doctrine, and to understand the selection of electric drive. These hearings were the most important forum for organizations to influence the ship design process decisively, and it was usually the final chance to do so before recommendations were made to Congress. Record Groups 19 and 80 provide important background information that is needed to understand the hearings in the context of the overall submarine development process. This study also draws on the technical literature to a greater extent than others in order to appreciate the engineers'

perspective and to understand the technological difficulties that they faced. Finally, the secondary works consulted provided invaluable background and context for both the submarine and railroad industry issues.

CHAPTER II

THE REAL FLEET BOAT

As the antagonists in the Great War poured resources into the development of weapons, by 1918 the U.S. Navy had seen its submarine capability fall far behind that of the world's leaders. This is not particularly surprising since the Americans joined the war so late, but the U.S. Navy had ambitious plans. At the outset of war, the Americans had only a handful of short-range obsolescent craft, but, by early 1918, a program was being drafted to build a fleet of some 393 American submarines.¹ The vast majority of them were to be small, short-range submarines, mainly because that was all that the Americans had experience designing and building. But the boats that captured the bulk of the attention, from line officers and engineers alike, were thirty-three large submarines being designed to accompany the battle fleet. These "fleet submarines," as they were called, were inspired in part by an experiment then underway in the British Royal Navy known as the K class. Before delving into the K class, however, it is important to define some terms.²

There is a surprising lack of consistency in submarine nomenclature within the sources so it is worthwhile to discuss the naming convention used in this study. At this time there were two basic categories of submarines: coastal boats (called coastals) and

¹ General Records of the Department of the Navy, 1798-1947, General Board Subject Files, 1900-1947, Record Group 80, National Archives Building, Washington, D.C. (hereafter RG 80/GB), letter from the General Board's senior member to the Secretary of the Navy, subject: "Submarine Building Policy," April 20, 1918, File GB 420-15, 1918-1920.

² The discussion will be confined to terminology used for German and American submarines of the First World War or the interwar period. There were many other submarine types used by other navies of the world, but discussion of them here is not germane. Because of conflicting information in the sources, the terminology used here will differ from other matter in some cases. The term "boat" will be used interchangeably with submarine, as was the convention among submariners before the nuclear era.

ocean-going boats.³ There were seemingly innumerable variations of ocean-going submarines in the world, but almost all American boats designed between the world wars can be placed in three subcategories: minelayers, fleet submarines, and cruisers. Fleet submarines and cruisers accounted for all but three of the American submarines that were both designed and built in the interwar period.

The concept of the fleet submarine was driven by the U.S. Navy's battleship doctrine, which descended from the teachings of Alfred Thayer Mahan, who in 1890 first published his theories in *The Influence of Sea Power Upon History, 1660-1783*. The primary function of all ships, including the submarine, was to help battleships maneuver into decisive combat with an enemy's battleships, a strategy that had changed little since the days of Lord Nelson. The battleship doctrine influenced the design and use of almost all other ships, which could therefore, all be considered auxiliaries to the battleship during this period. Aircraft carriers were no exception. Despite the impressive potential of naval air power, carrier-based aircraft were expected to be the eyes of the battleships; they were to find the enemy, defend the battleships, and assist with gunnery spotting.⁴ Air power advocates openly contested this role throughout the interwar period, but the aircraft carrier did not become the undisputed capital ship of the fleet until well into the Second World War. Submarine advocates, on the other hand, could only dream about that kind of independence. As a result, submariners had to frame their mission in a way that was compatible with the battleship.

The most significant other school of naval strategy was commerce raiding, which

³ Ocean-going submarines are also called "offensive submarines," and coastal submarines are called "defensive submarines" in some sources.

⁴ As late as 1937, carrier pilots spent three-fourths of their flying time in support of battleship gunnery work. See McBride, *Technological Change*, 197.

was practiced by the Germans during both world wars and by many navies in the Second World War. Most naval theorists viewed this mission with disdain, though not because of ethical or legal concerns; there were, after all, civil ways to conduct commerce warfare. The theorists simply believed it was a distraction from the most important mission, which was to eliminate the ability of the enemy to control the seas. Once that was accomplished, the fate of an adversary that relied on sea-borne commerce was sealed, or so the thinking went.

Much like its surface ship namesake, a cruiser was a submarine capable of operating independently in foreign waters at great distances from its home base. Its chief characteristics were long range (10,000 to 20,000 miles), moderate surface speed (15 to 20 knots flank), medium to large displacement (1000 to 2200 tons), large torpedo complement, and one or more large deck guns.⁵ The propulsion plant required to make higher surface speed was sacrificed to allow for greater fuel storage and for provisions needed on relatively long deployments (60 to 90 days). Cruisers came of age in the German navy late in the Great War, and it was this type of boat that captured the

⁵ No measurement is ideal, but displacement generally provides the most useful measure for distinguishing between submarine sizes, as opposed to length, beam, or draft, for example. Surfaced condition displacements will be used throughout; this was the convention of the period when citing only one displacement value. "Standard" displacement is cited throughout unless otherwise noted. The London Naval Conference defined standard displacement as displacement of a ship fully loaded and armed, ready to go to sea, except not accounting for fuel on board. Citations are not given for the various ranges of ship characteristics used here, because the information is drawn from too many sources. However, all information comes from sources cited herein. Exceptions can be found to the ranges cited, but they are few. Whenever units of "miles" are used, they are intended to mean nautical miles throughout. Maximum (or flank) speed was rarely attained since engines were generally overloaded at that speed. Engines required frequent maintenance, so prolonged operation (several hours) at flank speed considerably reduced the engines' maintenance intervals. Nevertheless, flank speed is a useful benchmark. In addition to flank speed, specifications normally contained a lower top surface speed and endurance at that speed. Of course, flank speed was attained on the surface. Submerged speeds were much lower for submarines; most could not exceed about 8 to 10 knots submerged until the German Type XXI and Type XXIII were built late in the Second World War.

imagination of forward-thinking American submarine officers between the world wars.⁶ American planners and designers occasionally used the terms “patrol” submarine and “scout” submarine, but these were essentially different names for a cruiser, no doubt influenced by the mission envisioned by the individual. Those who wished to emphasize the independent side of the cruiser’s capability were more prone to use the term “patrol,” and those who wished to emphasize its value to the fleet would be more likely to use the term “scout.” The differences are unimportant except in technical discussions.

The American “fleet boat” of the Second World War really should have been called a cruiser, as it was until about 1932. There seems to be no overriding reason that the confusing “fleet boat” designation was adopted for modern submarines, but there are numerous contributing factors.⁷ The battle fleet role was popular among the admirals and there were some who, even late in the period, insisted that submarines should be able to act in close coordination with the surface fleet. Submariners, of course, picked up on this, and so they gave the mission undue emphasis at times, even though very few of them believed in its efficacy.⁸ Perhaps the term cruiser was abandoned because many

⁶ Although the Germans pioneered the cruiser type, they abandoned it in the Second World War in favor of smaller boats. This was done in part because long-distance cruising was not a criterion for German designers in the 1930s, but it was also done for the reasons of economy: the smaller their size, the more boats that could be constructed on a finite budget.

⁷ In this study, modern submarines are considered those beginning with *Porpoise* (SS-172). These were the first submarines of the interwar period built in significant quantities (at least four per year), and they also represent the point at which interwar design efforts began to converge on a standard all-purpose submarine. See appendix A.

⁸ A good illustration of this is the candid observations of Commander Joseph Fisher, who spent the First World War in Great Britain observing Royal Navy submarine operations for the U.S. Navy’s Bureau of Engineering (see United States Navy Department, Bureau of Engineering, *History of the Bureau of Engineering, Navy Department, during the World War* (Washington D.C.: GPO, 1922), 8). After the war Fisher told a group of battleship admirals: “I can’t conceive of a fleet using a submarine in battle. I can’t conceive how she would control it and how she would use it if the other fleet wanted to avoid battle.” See United States Navy Operational Archives, Naval Historical Center, Washington, D.C., *Hearings before the General Board of the Navy, 1917-1950* (Wilmington, DE: Scholarly Resources, Inc., 1983), microfilm, (hereafter HGB), Reel 3, “Proposed Design for Fleet Submarines,” February 7, 1919, frame 96.

viewed the larger German cruisers of the First World War as the ultimate in cruiser design, and those vessels were considerably larger than the modern American fleet boat.⁹ The fact that the navy changed the designation of some of the large V-class boats built in the 1920s from fleet type (SF) to cruiser type (SC) supports that interpretation.¹⁰ John Alden has also suggested that the fleet boat designation may have been retained because it was familiar to Congress, and the navy leadership was reluctant to convey vacillation for fear that congressmen might allocate lower funding as a result.¹¹ Regardless of the reasons behind it, the fleet designation as used in reference to the boats of about 1933 and beyond is equivalent to a cruiser. The term as used before then referred to the high-speed submarines described below.¹²

The world's first and only (battle) fleet submarines that deployed in any significant numbers were the British K class. The type's distinguishing feature and its ultimate undoing was its use of a steam propulsion system. The K-boats were fitted with oil-fired boilers that produced steam to power turbines that could drive the submarine at a surface speed up to 25 knots, which made them the fastest submarines in the world. The air exhaust and intake requirements of this system required far more hatches than usual, and, of course, more hatches meant more places for something to go wrong. The boats had

⁹ The Germans built cruisers with displacements between 800 and 2200 tons. The larger cruisers had two large deck guns with sponsons surrounding the guns for the gun crews. They also carried a large quantity of shells, as the boats intended to interdict most vessels on the surface. The cruisers of more moderate size, which are analogous to the later American fleet boats, did not have as much deck and stowage space, and did not necessarily have two guns. See V. E. Tarrant, *The U-Boat Offensive, 1914-1945* (London: Arms and Armour, 1989), 169-72.

¹⁰ The navy vacillated on its submarine designations frequently during the interwar period. Some boats had as many as four different designations during their service life.

¹¹ There is ample evidence in interwar correspondence that planners were sensitive about altering recommendations after they were made, but it is sometimes difficult to tell when it was a legitimate reason and when it was a convenient excuse.

¹² Alden, *The Fleet Submarine*, 12.

two retractable funnels that had to be sealed after extinguishing the boiler fires while rigging for submergence – an exercise that took at least five minutes, compared to thirty seconds to one minute for a diesel-powered boat. The boiler room and its surroundings suffered from an enormous amount of residual heat after extinguishing the fires. As a result, the room had to be isolated and evacuated immediately after submerging and, even so, the adjacent compartments got far too hot for a short while (even in the cold waters off the British Isles). The K-boats were large for submarines of the day, displacing about 1850 tons, in order to accommodate the machinery needed to achieve high speed. However, they still had a very small operating radius, less than 3000 miles, because of the inherent inefficiency of steam propulsion. They were also not very seaworthy; a bulbous bow had to be fitted after the design's introduction in order to provide the necessary buoyancy forward to allow the boat to ride over waves. The original bows in the 339-foot long submarines tended to plow, pitching the forward end of the boats downward and swamping their decks. In reality they could not achieve higher speeds except in very light seas.¹³

Throughout the war the K-boats operated under a veil of secrecy. So convinced were the British admirals of the value of the type that they were careful not to release any photographs that showed the funnels raised. They reasoned that if the Germans found out that the British were putting steam into submarines, it would only be a matter of time before the Germans launched a crash program to build their own. In so reckoning, the British overreacted to Tirpitz's twentieth-century challenge to their battleship fleet, as they were deathly afraid of anything that could give the Germans an edge. They could

¹³ Don Everitt, *The K Boats: A Dramatic First Report on the World's Most Calamitous Submarines* (New York: Holt, Rinehart, and Winston, 1963), 13-54.

not have been more mistaken.¹⁴

The viability of fleet submarines was dramatically revealed in an operation known as the Battle of May Island in February 1917. The scripted fleet exercise, not an actual battle, called for the close operation of forty ships including battleships, cruisers, destroyers, and nine K-class submarines, all to occur in darkness, with radio silence, and only one stern lamp lit on each vessel. Before the operation was abandoned, six submarines were involved in collisions, two of which sank with heavy loss of life. The fleet advocates failed to accept what submariners knew all too well; surface ships had a hard enough time reliably spotting submarines in daylight, much less under cover of darkness.

After the exercise, a court of inquiry was held to punish the innocent, the commanders of the ill-fated boats, but the Admiralty did not acknowledge any fault in its doctrine. The clandestine environment in which the boats were developed and operated shielded their frightful performance. Twenty-one K-boats were commissioned into the Royal Navy, eight of which eventually sank due to mishaps, all without ever engaging the enemy. The K-boats were quietly phased out after the war's end and the British released no public information on the project until after the Second World War.¹⁵

Despite the secrecy surrounding the K-boats, the U.S. Navy was well aware of their performance through its liaison activities with the Royal Navy. At least one American submarine officer, Commander Joseph O. Fisher, went to sea on a K-boat (K-5) during the war and filed a detailed report. Based on his observations, it is appears that the

¹⁴ Ibid., 13-54. Actually, the Germans were already working on steam submarine designs, but they did not build any. They offered to sell the plans to the U.S. Navy in 1921.

¹⁵ Ibid, *The K Boats*, 109-52.

British went to great lengths to disguise the bad experiences of the class. It is unclear whether American officers were aware of the results of the Battle of May Island; there is no evidence of this in the sources. Considering the close ties between the two services, however, it is almost certain that the Americans were informed off the record. Regardless, Fisher's report to the Navy Department and other discussions in the sources do convey that the British submarine officers did not have much confidence in the future of steam-powered submarines.¹⁶

At first glance it seems hard to understand the British experiment. There was no shortage of experts who, even then, advised against using steam propulsion on a submarine. Perhaps the most notable was Great Britain's First Sea Lord, John "Jackie" Fisher. Even though Fisher was a fleet submarine advocate, he pointed out in 1913 that "the most fatal error imaginable would be to put steam engines in a submarine." One year later, even Fisher gave in to the steam engine proponents. Such was the power of the prevailing battleship doctrine.¹⁷

As a result of the British experience an unusual marriage of convenience emerged in the American submarine community. The state of the art dictated that steam propulsion be used in order to achieve the desired fleet speed of 25 knots. The best that an American diesel propulsion system could provide was believed to be 20 knots, although in reality it was closer to 17 or 18. Captain Thomas C. Hart, a small-submarine

¹⁶ RG 80/GB, memorandum from Commander J.O. Fisher to the Navy Department via the Bureau of Steam Engineering, subject: "British steam submarines K-1 to K-17 inclusive," September 14, 1918, File GB 420-15, 1918-1920.

¹⁷ Everitt, *The K Boats*, 11. Some may consider Jackie Fisher a battleship admiral since he championed the design of H.M.S. *Dreadnought* during his earlier tenure as First Sea Lord in 1905. By the First World War, however, Fisher had become skeptical of an overly heavy commitment to building expensive battleships. Support of battle cruiser and submarine development are examples of his more innovative thinking, and he did not limit his support of submarines to the fleet service role.

proponent for his entire career, led an early effort to convince the General Board to abandon the fleet submarine concept.¹⁸ With the support of Commander Chester Nimitz, Hart prepared a paper for the board on submarine propulsion that was backed by Bureau of Engineering chief Rear Admiral Robert Griffin.¹⁹ Hart concluded: "The [Submarine] Board therefore recommends that steam be not used for submarines of the current programme, and be not attempted at any time unless a design be produced that is much more promising than any now available. Diesel Engine propulsion is recommended for the 'Fleet Submarines.'"²⁰

However, the General Board reserved its final decision until Commander Emory Land, then the head of the Submarine Design Department in the Bureau of Construction & Repair, could return from an inspection tour of German submarines turned over to Great Britain after the war.²¹ When he returned, he added his voice to those of the other submarine men before the board:

You gentlemen have given me an impossible problem, because you want two things that the present state of development will not give, that is, a large radius of action and 25 knots speed. . . . Therefore, I adhere to a recommendation previously made that we build one or two steam

¹⁸ HGB, Reel 1, "Submarine Building Program," February 27, 1918, frames 356-72. Fleet speed was 21 knots at the time, but improvements were on the horizon and that value was expected to rise. The General Board was a group of senior admirals that served as an arbiter for the technical and sea-going community to arrive at recommended types of ships. The navy's organization will be discussed in the next chapter. Hart was then chairman of an early submarine board serving under the Chief of Naval Operations. It was highly unusual for someone outside BUENG to author such a study. This was a reflection of Hart's prominence in the submarine community just after the First World War.

¹⁹ The Bureau of Engineering was called the Bureau of Steam Engineering until 1920, but it will be referred to as BUENG throughout this study. Commander Nimitz was then one of the leading diesel engine experts in the navy.

²⁰ HGB, Reel 2, "Surface Power Plant for Large Submarines," December 20, 1918, frame 1356. Note that it was conventional in this period to capitalize the word "Diesel."

²¹ Despite being the leading submarine naval architect in the navy, Land spent much of his time between July 1918 and late 1920 in England, attached to the staff of William Sims, who commanded all U.S. naval forces in Europe during the war. Land probably had the closest ties to British submarine designers of any American.

submarines [ostensibly to test the type, but probably to placate the senior members of the board], but that the remainder of these nine submarines have Diesel engines. I know that is not a satisfactory answer, but I defy any one to give a satisfactory answer in the present state of development.²²

Though two more hearings were held in the following weeks to air other views, the submarine designers and operators won their case.²³ Thanks to the impracticality of steam propulsion systems on submarines and the technological limitations of diesel engines, the submarine began its slow detachment from the battle fleet.

²² HGB, Reel 3, "Fleet Submarines," February 6, 1919, frames 59-78. The number of fleet submarines under consideration was reduced from thirty-three to nine due to sharply reduced budgets after the war.

²³ The term "operators" will be used interchangeably with submarine line officers. However, note that some officers objected to the term because of the eternal tension between engineers and line officers over their respective roles. Engineers believed it was their domain to design and build the boats and that it was the officers' duty to operate them. Submarine officers, of course, wanted more influence over the designs, since they were in the best position to evaluate the relative merits of the final product. The term is not being used to take sides in the fray; it is used because it is descriptive.

CHAPTER III

ORGANIZATIONAL RIVALRIES

The 1919 hearings demonstrated a degree of cooperation between the operators and the bureaus that belied the tremendous organizational rivalries between officers of the line and the bureaus' engineers. Since 1842 an extensive technical bureaucracy had risen to power in the U.S. Navy due to its unique need for sophisticated weapon systems (see fig. 1).¹ The bureaus most critical to ship development were the Bureau of Engineering (BUENG), the Bureau of Construction and Repair (BUC&R), and the Bureau of Ordnance (BUORD), collectively known as the technical or material bureaus. Each bureau had a centralized organization that was overseen by a bureau chief.

BUC&R's "naval constructors" were naval architects, primarily responsible for basic hull design, layout of compartments and tanks, equipment integration, and any design function not associated with propulsion plants or weapon systems. Naval constructors were also assigned to important ship construction management tasks at the various shipyards. The naval constructors were former line officers who were rotated from an at-sea command into a three-year marine engineering and naval architecture program at the Massachusetts Institute of Technology (MIT).² Officers graduating from this elite program were exempted from future sea duty in order to encourage the

¹ For background on this development see Benjamin Franklin Cooling, *Gray Steel and Blue Water Navy. The Formative Years of America's Military-Industrial Complex, 1881-1917* (Hamden, CT: Archon Books, 1979). The U.S. Army had no need for a comparable organization since its technological needs at this time were much more basic. This discussion is geared toward submarine design; the descriptions would differ somewhat for surface ship design.

² The program at MIT was created in 1901. Prior to its establishment the few naval constructors who received postgraduate education went to either the Royal Naval College in Greenwich, England, the *Ecole d'Application du Génie Maritime* in Paris, or the University of Glasgow, preferred in that order.

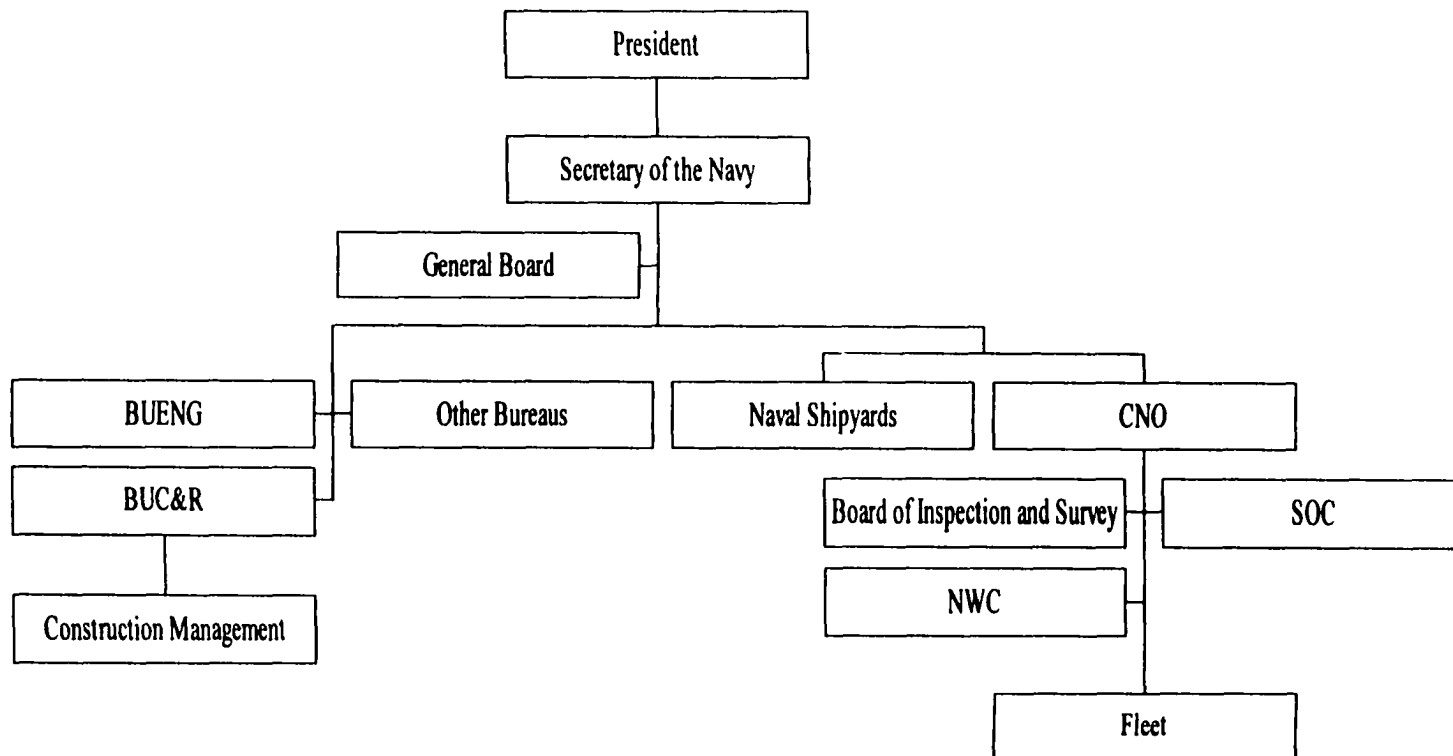

Fig. 1. Interwar Navy Department Organization

Sources: Alden, *The Fleet Submarine*, Robert H. Connery, *The Navy and the Industrial Mobilization in World War II* (Princeton, NJ: Princeton University Press, 1951), and other references cited herein.

development of technical specialties and were designated as EDO, or Engineering Duty Only. As a result, naval constructors had considerable formal and practical education: some earned a bachelor's degree before entering the naval academy, and all had a degree from the academy and a Master of Science degree from MIT. They also served as "Fleet Naval Constructors," who accompanied ships on deployments to resolve naval architecture issues firsthand, and they worked their way up to commands in the fleet. BUENG officers were products of a program that was similar, but not quite as ambitious. After leaving the naval academy and after considerable experience with the fleet (command of a ship was not required), officers entered a post-graduate technical program that consisted of one year of work at the naval academy and one year at Columbia University. Despite the excellent education and the extensive experience in the fleet, or perhaps because of it, a rift was always present between the technical bureaus and the operators.³

The members of the third technical bureau, BUORD, had an overarching influence over ship design and operation. Its members directed the design of all weapons, and the weapons of choice in all early twentieth-century navies were the large-bore, long-range naval cannons that were at the heart of the battleship. Outsiders derisively referred to BUORD and other battleship proponents as the "Gun Club" or as "blackshoes," but they exerted a decisive influence on the development of almost every type of vessel. Submariners depended on BUORD for the design and manufacture of deck guns and torpedoes, and pervasive torpedo problems in the early 1940s would spark bitter confrontations between the bureau and submarine operators.

³ United States Navy Department, Bureau of Construction and Repair, *History of the Construction Corps of the United States Navy* (Washington D.C.: GPO, 1937), 37-42.

The technical bureaus' specialized engineering knowledge was the key to their independence and power. In submarine design matters this was even more pronounced because there were so few engineers and naval constructors with submarine design experience. The chief of each bureau reported directly to the Secretary of the Navy, as did the senior line officer(s). The fact that the secretary was a civilian appointee of the president significantly enhanced the influence of the chiefs. The president filled the position essentially as a political payback; hence, secretaries were never naval experts. Also, because the turnover of the office between the world wars was frequent, the secretaries tended to accept the advice given them by the bureau chiefs. Thus, the bureau chiefs indirectly wielded the power of the president unless he or the secretary intervened, which they did only infrequently, at least before Franklin D. Roosevelt became president in 1933.⁴

Line officers vigorously opposed the naval engineers' control of ship technology. An attempt to check the power of the bureaus was institutionalized in 1900 with the creation of the General Board, by executive order of the president. The General Board was a board of senior admirals, all former line officers, charged with formulating naval strategy and recommending types of ships to the Secretary of the Navy, the president, and ultimately to Congress. The board held regular hearings that allowed the bureaus, the line officers, the Naval War College, and the Chief of Naval Operations (after 1915) all to have input into the types of ships that were recommended.

The line officers gained another important foothold in 1915 with the creation of the Chief of Naval Operations (CNO). This long-debated position was established at the

⁴ Connery, *The Navy and Industrial Mobilization*, 14-30; Bureau of Construction & Repair, *History of the Construction Corps*, 45-47.

conclusion of a bitter dispute between Secretary of the Navy Josephus Daniels and Admiral Bradley Fiske, his aide for operations. Fiske dearly coveted a general staff for the U.S. Navy along the lines of the ones that had been established in England, Germany, and Japan. At the time the aide for operations was roughly equivalent to the modern CNO, but the secretaries kept far more control over fleet maneuvers than in the post-1915 navy. In 1914, Daniels, whom Fiske considered a pacifist, repeatedly rebuffed Fiske's proposals for a general staff, as the war raging in Europe only reinforced the convictions of each. Daniels, like his president, Woodrow Wilson, was deeply distressed about the rising forces of militarism in the world and considered Fiske's ideas a grave danger to peace. Daniels also did not want another layer of management between him and the fleet. Without Daniels's knowledge, Fiske took his case to a congressman who was a member of the Naval Affairs Committee, Richmond P. Hobson. Hobson happened to be a former BUC&R naval constructor so he naturally had a keen interest in naval affairs. He was able to get a rider on the naval appropriations bill of January 6, 1915, which created the CNO's office, with a staff of fifteen officers as assistants. Daniels was furious, as he felt the bill would reduce him to "somewhat between a figurehead and a rubber stamp," as he said before Congress. He enlisted powerful allies to fight Fiske, and he was able to strike the 15-officer staff, but over his objections the office was established on March 3, 1915. As finally drafted in the law, the CNO's duty was to direct the operations of the fleet in war and to advise the Secretary of the Navy on matters of naval strategy, thus removing that responsibility from the General Board, which focused on approving types of ships until it was disbanded in 1950. Though one might expect these changes to have given the line officers control of the ship design process, the bureaus proved difficult to subdue.⁵

⁵ RG 80/GB, A. W. Johnson, "A Brief History of the Organization of the Navy Department," March

The bureaus naturally resented the CNO because they feared he would dilute their influence and, indeed, the CNOs tried. Every CNO but one lobbied the president to give him control of the bureaus, but these efforts were always rejected in the interests of preserving what was believed to be a more balanced organization.⁶ The CNO's war-planning function, however, did increase the influence of CNOs over the course of the interwar period. In this role, they relied heavily on the Naval War College, which promoted naval strategy based on studies carried out at the college and war games that were held annually to test and analyze tactics and strategy. The war college was the ultimate guardian and a leading supporter of the prevailing battleship doctrine, which was systematically taught to rising young officers. As a result, the war college played a key role in constraining the development of innovative submarine tactics and strategy between the world wars.⁷

The CNO's only real leverage in ship design came with his influence through the line officers of the General Board, and at times that was significant. However, the General Board was handicapped by its members' technical shortcomings, so the bureaus still had tremendous influence over types of ships and their characteristics. The CNO did have the Board of Inspection and Survey, which evaluated ships during sea trials, reported deficiencies, and recommended acceptance or refusal at the completion of their contracts. Of course, outright refusal of an expensive ship was an impossible proposition,

1933, 2318-23, File GB 446, 1921-1922.

⁶ Samuel P. Huntington, *The Soldier and the State: The Theory and Politics of Civil-Military Relations* (Cambridge, MA: Belknap Press of Harvard University Press, 1957), 301-3.

⁷ Connery, *The Navy and Industrial Mobilization*, 14-30; Huntington, *Soldier and the State*, 301-3.

but the board's findings could lead to negotiations to resolve differences and provide compensation to the government.

Controversy was the rule rather than the exception when it came to interactions within the Navy Department. Samuel Huntington, a notable civil-military relations authority, points out that the system was effective (compared to the army's), but only at the cost of constant bickering and friction among the Secretary of the Navy, the CNO, and the bureau chiefs.⁸ A review of the U.S. Naval Institute *Proceedings* of the period reveals that dissatisfaction with naval organization inspired many a commentary, including contrast and comparison with various European models. One early antagonist, Commander Yates Stirling, won an Honorable Mention award from the institute in 1913 for his analysis of the principles of naval organization. In this early work, Stirling proposed holding the bureau chiefs more accountable for results, correctly pointing out that the chiefs were using the secretary's office as a shield to advance their agendas. Stirling became a vocal critic of and an important factor in submarine development throughout the interwar period.⁹

One of the surprising characteristics of the Navy Department in this period is that, despite an organization that appeared intentionally to set all parties at odds with each other, at the same time it showed a surprising tolerance for dissent, at least within the ranks. This philosophy extended over a wide span of issues, whether they were technical,

⁸ Huntington, *Soldier and the State*, 301-3.

⁹ Yates Stirling, "Organization for Navy Department Administration: A Study of Principles," *United States Naval Institute Proceedings* 39 (June 1913): 436-99.

organizational, or matters of tactics and strategy. It is unlikely that professional reprisals were rampant as a result, or else the practice would not have continued unabated.¹⁰

Open dissent notwithstanding, the one unassailable concept of the day was the primacy of the battleship as the center of gravity of the battle fleet. No matter how submarine adherents, like their aviation colleagues, longed for a more prominent role, they recognized that they had to work within the constraints of the prevailing battleship doctrine.¹¹

¹⁰ Perhaps the most famous example of this is the case of William Sims, a line officer who vigorously attacked BUC&R over battleship design issues as a mere lieutenant. Sims rose to command all naval forces in Europe in the First World War where he continued to provoke conflicts with the bureaus that eventually prompted congressional intervention. See McBride, *Technological Change*, 51-59, 195-96.

¹¹ *Ibid.*, 67, 122.

CHAPTER IV

THE U-BOAT CONTROVERSY

When the Americans formally entered the Great War in April 1917, the U.S. Navy's submarine force was ill prepared to contribute much to the effort. All the Americans could muster from their meager forces were eleven obsolete coastal boats, each of which crossed the Atlantic on the after end of a tow line, led by tenders and tugs. Due to the poor material condition of the boats, despite the best efforts of Yates Stirling, who commanded them before the war, they did not depart for Europe until October and November 1917. The crossings were conducted over heavy seas and through bad weather, which resulted in occasional scattering of the boats, and the old coastals sometimes had to fend for themselves for days at a time. When the flotilla finally formed up, the boats operated out of the Azores and at a base called Barchaven in Bantry Bay, Ireland. The force, which was led by Thomas Hart, operated mostly on weeklong anti-U-boat patrols and, although there were some close calls, the Americans failed to sink a single ship.¹

Nevertheless, the experience was instrumental to the future of U.S. submarines for a number of reasons. Captain Hart and his young charges gained an in-depth appreciation of the rigors of submarine warfare while conducting the crossing and their patrols. Numerous sightings and several approaches and attacks were made on U-boats, an experience that could not be replicated by drills. Furthermore, Hart spent a considerable

¹ James Leutze, *A Different Kind of Victory: A Biography of Admiral Thomas C. Hart* (Annapolis: Naval Institute Press, 1981), 56-64; Harley F. Cope, "U.S. Submarines in the War Zone," *United States Naval Institute Proceedings* 56 (August 1930), 711-16. There were four K-class boats (400-ton coastals having nothing in common with the large British K-boats) in the first crossing and seven L-class boats (also about 400 tons each) in the second.

amount of his time canvassing the British submarine community, including a six-week tour of the British submarine command. It is likely that Hart learned much about the British K-class experiment during this time, and everything he learned reinforced his pre-conceived view of the need for the smallest practicable boat with well-trained, dedicated crews and, mirroring the German approach, minimum attention to habitability and crew comfort, what Hart derisively referred to as “hotel facilities.” Before being rotated back to the United States, Hart conveyed his assessments to acting-Rear Admiral Samuel Robison, who, along with his chief of staff Lieutenant Commander Chester Nimitz, was touring Great Britain for similar reasons.²

But the lesson that fueled a debate between line officers and engineers that lasted for decades came when Hart’s submariners returned to Great Britain in 1919. After the war Hart was designated as the CNO’s first Director of Submarines, and he and his men implored the Secretary of the Navy to authorize acquisition of some old German U-boats, to bring them to the U.S. for testing and study. After many fruitless attempts, the men were finally able to gain approval by convincing some presidential cabinet members that the U-boats could be used as part of a post-war “Liberty Loan” campaign, touring U.S. harbors and selling bonds from the decks of the notorious raiders. Actually, it is uncertain who was responsible for launching this effort. Both Hart and his assistant, Lieutenant Commander Freeland Daubin, said that exploiting the bond fund was their idea, and both say that they initiated contact with the cabinet members. Emory Land, the head of BUC&R’s submarine design department from 1917 through 1919, also takes credit for the idea in his autobiography: “There was much backing and filling until February 4, 1919, when I returned to the United States [from inspecting U-boats in Great

² Leutze, *A Different Kind of Victory*, 56-64; Cope, “U.S. Submarines in the War Zone,” 711-16.

Britain] and wrote to the Secretary of the Navy, successfully urging that we acquire the U-boats.”³ Regardless of who should get the credit, in February Hart dispatched Daubin along with 132 officers and sailors to bring back the best six boats they could find at the U-boat storage area in Harwich, England.⁴

Unfortunately for Daubin and his men, when they arrived they found that the British, French, and Japanese had already taken the best of the lot. Furthermore, those boats that were left had suffered a considerable amount of damage, some at the hands of the Germans just prior to surrender. Much of the damage, however, was inflicted by the British, who took sledgehammers and hacksaws to the boats not set aside for study. Exercising extraordinary ingenuity and perseverance, the group managed to get six serviceable U-boats back to the U.S. by late April. Daubin’s U-111 beat the others by several days after a risky journey back via the Great Circle route.⁵ The officers who sailed the boats back to the U.S. were unflinching in their praise for what to them were marvels of German technology. During and after the Victory Loan campaign, the CNO’s Board of Inspection and Survey conducted extensive performance testing on the captured

³ Emory Scott Land, *Winning the War with Ships: Land, Sea, and Air - Mostly Land* (New York: Robert M. McBride, 1958), 84-111. Land, then a commander, was more influential than Hart despite the fact that Hart was a captain, because Land was far more effective at cultivating political relationships than Hart was, and due to the prestige of BUC&R. Land developed connections with the Roosevelt family dating back to Theodore Roosevelt’s administrations.

⁴ Leutze, *A Different Kind of Victory*, 67; Freeland Daubin, “Cruise of the American *Unterseeboot* 111,” *United States Naval Institute Proceedings* 83 (March 1957): 259-71.

⁵ Leutze, *A Different Kind of Victory*, 65-70; Daubin, “Cruise of the American *Unterseeboot* 111,” 261. The boat was not ready to depart when the other submarines and escorts left, so the fuel capacity of U-111 dictated that they take the Great Circle route. Otherwise they would have had to wait for another escort to arrive, which was not expected to occur for months. Daubin’s crew endured a grueling series of hardships during the crossing; theirs was the only U-boat to sail back without escort. Their radio was useless, they had no life rafts, and they overcame instances of “delayed-action” sabotage left by the Germans, including an ingenious water-soluble plug that almost sank the boat in mid-ocean.

U-boats and, along with the reports of the commanders who had sailed them across the Atlantic, the seeds for a long-running debate were sown.⁶

Land and the naval constructors at BUC&R were far less smitten than the submarine line officers. In a hearing before the General Board, Land declared that he was most impressed with the U-boat engines. (Note that engines were outside his purview.) He reported to the board that the “Diesel engines on these submarines are superior to any other submarines in commission in the world.” He also cited German superiority in periscopes (no one questioned the superiority of their optics), radius of action, and double hull construction. But he was also remarkably negative about many U-boat features. Regarding the complexity of German shipboard systems, Land said “personally, I was very much disappointed because I had expected that a nation who had spent as much time and money on submarines as they have, would have evolved a system of installation leaning toward simplicity.” Many in BUC&R reckoned that the U.S. Navy could do better with similar funding and priority. At times Land displayed a surprising amount of arrogance, considering the quality of the German boats. When he was asked by the board about his impressions of the German submarine campaign, Land said that “it was not conducted as well as either the British or Americans could conduct it, for the reason that the morale of the submarine navy is inferior to the morale of the British or our own.” Considering the nightmarish conditions that the Germans operated under, and their impressive successes, Land’s remarks were well off the mark.⁷ Perhaps he was

⁶ For example, see General Records of the Department of the Navy, 1798-1947, Secretary of the Navy, Confidential Correspondence, 1919-1927, Record Group 80, National Archives Building, Washington, D.C. (hereafter RG 80/SECNAV), Board of Inspection and Survey report, “Report of Trial, Ex-German Submarine UB-148, Held Nov. 2-7, 1919,” November 18, 1919, File PD-123-3, 1919-1920.

⁷ The Germans sank 13 million tons of allied shipping at the cost of 178 U-boats lost, an average of 73,000 tons for every submarine sunk.

posturing for the battleship admirals on the board, or perhaps he really believed it out of professional pride. But his comments before the board that day reflected the prevailing attitude in BUC&R.⁸

The U-boat critics in BUC&R were also piqued by the public's perception of German superiority. The German submarine warfare campaign, the first in world history, had both shocked and awed those who followed the war in the newspapers. In 1919 an exercise was staged to compare one of the captured U-boats with a "modern" American S-boat. In a subsequent *New York Times* article, Assistant Secretary of the Navy Franklin Roosevelt spoke for the Navy Department. Roosevelt declared, "While details of the comparative comments cannot be given [publicly], sufficient information is available to destroy the much-advertised superiority of the German submarine." Roosevelt claimed that despite tuning the best of the U-boats, Daubin's U-111, prior to the special trials, it could only make 13.8 knots on the surface, compared to 14.7 knots for the S-3. Among other things, Roosevelt also echoed many of the complaints made by Land: "The U-111 is congested to the last degree; she is complicated in the extreme by many 'gadgets,' some of which are of doubtful utility and more doubtful necessity."⁹

These concerns, however, were not shared by the men who had sailed the U-boats across the Atlantic earlier that year. Lieutenant Commander Holbrook Gibson, who piloted U-117, had this to say:

Many submarine officers and men and naturally most everybody who is not familiar with submarines generally leave the German submarines after a casual visit or inspection and state that it is full of wheels and machinery and gadgets. The mass of wheels and piping and

⁸ HGB, Reel 3, "Fleet Submarines," February 6, 1919, frames 59-81.

⁹ *New York Times*, "Our Submarine Wins U-boat Test: United States Type Shows Superiority in Nearly Every Respect," September 7, 1919. The word "gadget" was a mantra among critics of the German boats. Critics used the term in the sense of a mechanical device that is far too complex for its intended function.

instruments . . . seems almost fathomless and also needlessly complicated even to those who are familiar with submarine construction. However, . . . familiarity does not breed contempt but just the reverse. The technical German name plates and confusing maze of piping and valves gradually begins to mean something and the mystery disappears, and what seems at first to be a chaotic condition is just the opposite, a system down to a very fine slant and with almost endless details, but with it all extreme simplicity.

Gibson went on to rave about U-117 for nine typewritten pages in which he concluded that “comparing the German submarine with ours, taking item for item, machine for machine, equipment for equipment, I have not been able to find anything that is inferior to ours, but there are many, many cases where the German machinery is vastly superior.”¹⁰ Reflecting on the experience in 1930, Gibson explained why he believed that Land’s complaints about habitability were not valid. “Much has been said about habitability, and a comparison has been made on the basis of so many cubic feet of free space per man. In my opinion, this method of determining habitability is misleading and wrong. Habitability is a function of seaworthiness. A vessel that rides the sea with an easy motion, a dry bridge, maintains speed in a head sea, has fresh air in all compartments at all times, [and] is warm in cold weather is habitable. These qualities are found in the German design of submarine boat.”¹¹ The *New York Times* article was pure propaganda and the operators knew it.¹² After its publication, the Submarine Forces Afloat reexamined U-111 and had its engines properly tuned. Subsequent testing

¹⁰ RG 80/GB, Holbrook Gibson, “Report on German Submarine Construction,” undated by the author, but filed by the General Board November 1, 1920, File GB 420-15, 1918-1920.

¹¹ RG 80/GB, memorandum from Holbrook Gibson to BUENG chief Harry Yarnell, subject: “Recommendations Regarding Types of Submarines to be Built,” 1 August 1930, File 420-15, 1929-1930.

¹² It is likely that Land and Roosevelt collaborated on this episode. Roosevelt oversaw BUC&R activities during his tenure as assistant secretary and Land was assigned to accompany Roosevelt as a special aide on many occasions in 1919. See Land, *Winning the War with Ships*, 84-99.

revealed that the boat could actually achieve 17.1 knots, almost four knots greater than Roosevelt reported and well in excess of S-3.¹³

But Emory Land's outlook is what held sway among the coterie of American and British naval architects responsible for submarine design. Land wrote a paper on the topic which was delivered on his behalf before the Society of Naval Architects and Marine Engineers (SNAME) at its annual meeting in New York in November 1919. In it Land concluded by citing the aforementioned exemplary engines, periscopes, and large surface radius, but he followed that with a list of seventeen "objectionable features and defects" which leaves the reader with the distinct impression that the German boats were seriously flawed. The speakers who commented on the paper after its delivery generally endorsed Land's opinions, further illustrating the attitude among members of the profession.¹⁴

Before the senior British counterpart of SNAME, a similar paper was delivered four months later in London. The author presented a more balanced portrayal, which was followed by a more balanced commentary than was heard with Land's paper, but he still concluded that "so far as can be gathered from British officers who have been present on such trials [of captured U-boats], they prefer their own boats. There are, however, some details which they consider are better than in our boats." Commander Land, who was in the audience the night the paper was delivered, took the opportunity again to criticize the German submarines. While graciously complimenting the author, as was the custom, he

¹³ RG 80/GB, memorandum from Holbrook Gibson to BUENG chief Harry Yarnell, subject: "Recommendations Regarding Types of Submarines to be Built," 1 August 1930, File 420-15, 1929-1930.

¹⁴ Emory Scott Land, "Submarines in General – German Submarines in Particular," *The Society of Naval Architects and Marine Engineers Proceedings* 29 (November 1919), 111-25. SNAME was and still is the premier professional society for American naval architects. The Anglo-American bond among naval architects ran deep. Recall that prior to the creation of the naval architecture program at MIT, promising American constructors attended the Royal Naval College in Greenwich, England.

commented that “it [the paper] might have been more severely critical of German submarine construction for two reasons. One is that the Germans waited while the British, French, Italians, and Americans developed their submarines, and then they either begged, borrowed, bought or stole everything that they wanted. They then went ahead with their design and construction and then the world proclaimed them wonderful designers! Thus they obtained a credit which they did not and do not deserve.” Land went on to laud British submarines, including the ill-fated K class, and his comments no doubt went over well at this particular Anglo-American “family gathering.”¹⁵

Land’s technical views may have been colored by his attitude toward the Germans’ conduct of the war. On more than one occasion he defended the submarine with remarks such as these in his paper delivered the previous November: “Any implement of war and many implements of peace can be improperly and illegally used. As a matter of fact, most implements of war were improperly and illegally used by the Huns.” Land, however, would have found no sympathy for his views among the Americans who had to sail the products of his engineering expertise.¹⁶

¹⁵A. W. Johns, “German Submarines,” *Transactions of the Institution of Naval Architects* 62 (1920), 19-32. Johns was the leading submarine naval architect in the Royal Corps of Navy Constructors, the counterpart to Land’s position in BUC&R.

¹⁶ Land, “Submarines in General,” 111.

CHAPTER V

CRUISERS AND THE PACIFIC MISSION

The expected use of submarines in future conflicts was a topic of constant debate during the interwar years, and, as one would expect, end use was interwoven with design considerations. Once the original plan to integrate submarines into the battle fleet had suffered a setback, submariners and decision-makers throughout the navy argued for a variety of missions. Historians have shown that in many cases the projected use of a weapon did not drive its technological development as much as might be expected.¹ As the reader will see, however, the future American submarine mission had considerable influence upon the growth of the U.S. Navy fleet boat, though initially that influence was counterproductive.

Germany had already shown the world that the most efficient use of submarines was for the execution of commerce warfare. To be effective in this role, however, required the option of attacking without warning, the strategy known as unrestricted submarine warfare. Unrestricted submarine warfare, however, was a clear-cut violation of international law. In brief, international law stipulated that submarines could legally sink merchant vessels only under the rules of prize warfare. This required the submarine to surface, search the ship to confirm presence of contraband, and disembark the crew with probable likelihood of survival; e.g., the seas could not be prohibitive for lifeboats, the boats must be in reasonable proximity to land or friendly forces, etc. With stipulations such as these, submarine warfare was seriously constrained. During the First

¹ For example, Timothy Moy shows how the U.S. Army Air Corps' development of the long-range bomber was quite mature before a bombsight that could support precision bombing had been devised. See Moy, *War Machines*, 80-93.

World War, the British stretched the law (or violated it outright, depending on one's perspective) by arming merchant vessels, using decoy ships with heavy armament, and ordering armed merchantmen to fire on U-boats on sight. Despite perceptions to the contrary, outside of the period of unrestricted submarine warfare that commenced in February 1917, the vast majority of merchant ships sunk by German submarines were dispatched in accordance with the rules of prize warfare. But the key to the Germans' success had been that very few of the vessels confronted were armed or traveling in convoys. Prize warfare proved completely infeasible in the face of these impediments. The Germans also tried to establish exclusion zones such as the shipping approaches to Great Britain which neutral countries were warned to avoid. However, high-profile sinkings like those of the *Lusitania* and the *Sussex* ultimately turned public opinion against the Germans.²

The British and American publics were appalled by the German practice and their governments played to that sentiment with public protests against unrestricted submarine warfare during and after the war. A revealing glimpse into public opinion of the day was the fact that the American delegation to the Washington Conference of 1921-1922 received 422,488 messages from the public urging abolition of the submarine and only 4,199 favoring retention.³ The British tried to outlaw submarines altogether at the conference, because they had the most to lose by their existence. However, they succeeded only in having unrestricted submarine warfare banned, along with crafting an

² Tarrant, *The U-boat Offensive*; John Terraine, *The U-Boat Wars, 1916-1945* (New York: G. P. Putnam's Sons, 1989); Walter Stratton Anderson, "Submarines and Disarmament Conferences," *United States Naval Institute Proceedings* 53 (January 1927): 53-69. For a lively account of U-boat warfare based on interviews with U-boat captains, see Lowell Thomas, *Raiders of the Deep* (Garden City, NY: Doubleday, Doran & Co., Inc., 1928).

³ J. E. Talbott, "Weapons Development, War Planning and Policy: The U.S. Navy and the Submarine, 1917-1941," *Naval War College Review* 37 (May-June 1984): 58-59.

agreement laced with inconsistencies that just confused the issue. For instance, the right of submarines to conduct search and seizure in accordance with prize law was asserted in Article I of the submarine treaty produced at the conference. However, in Article IV, the treaty stated that it is practically “impossible” to use submarines as commerce destroyers, and that, therefore, prohibition of such use “shall be universally accepted.” The 1930 London Naval Agreement removed this inconsistency, but failed to deal with other internal contradictions such as the use of armed merchantmen. Submarines were allowed to conduct prize warfare, but merchantmen could be armed and fly false flags, rendering prize warfare impossible. To provide a meaningful agreement, armed merchantman should have been treated as auxiliary cruisers, and hence, not subject to the rules of prize law. That they were not was simply a reflection of the biases of the majorities at the conferences. In any event, a general prohibition against submarine commerce warfare remained throughout the interwar period.⁴

Despite this prohibition, during the interwar period American naval war planning began to evolve in a way that favored unrestricted submarine warfare. The first important step in this direction was the recognition that the likely enemy in a future war would be Japan. From 1906 until 1939, American naval war planners devised one plan variant after another in studies known as War Plan Orange.⁵ In War Plan Orange the hypothetical enemy was Japan, country “Orange” in the jargon of the planners, and the nature of the potential war with Japan was deduced early on. Japan, in its desire to

⁴ H. G. Rickover, “International Law and the Submarine,” *United States Naval Institute Proceedings* 61 (September 1935): 1213-27; Anderson, “Submarines and Disarmament Conferences,” 53-69; K. Mori, *The Submarine in War: A Study of Relevant Rules and Problems* (Tokyo: Maruzen & Co., Ltd., 1931).

⁵ Beginning in May 1939, American war planners also began accounting for the possibility that the U.S. could become involved in a European and Asiatic war at the same time by developing another series of plans, most of which were called the “Rainbow” plans.

establish a western Pacific hegemony, would attempt to drive Blue (the United States) from the region by capturing its island holdings and drawing its fleet into decisive battle; the Japanese also read Mahan. In response to this challenge, the Blue navy and an army expeditionary force would save or reestablish their western Pacific bases, secure their supply lines, and sever Japanese trade with all regions except northeastern Asia. After building up sufficient strength, the Blue forces would advance toward Japan with the goal of starving it of food, fuel, and raw materials by blockade and bombarding accessible targets until Japan capitulated. The details of how this blockade would be accomplished were left unspecified, but the groundwork was laid early for an unlimited economic war with Japan. Just how submarines were to be employed in this process, however, remained murky.⁶

Nevertheless, the critical operational criteria for future submarines were established surprisingly early following the Great War. In a General Board hearing on January 30, 1920, discussions centered on the nine fleet submarines originally planned for 1919 (later known as the V class). BUC&R's Land submitted specifications for a large-displacement boat of the fleet type, employing diesel engines that Land stated would allow the boats to make 18 to 20 knots top speed.⁷ In this same meeting, the War Plans Division of the CNO submitted two secret memorandums to the board outlining future submarine missions: "At the present time the most probable operating area is the Pacific. This condition will undoubtedly continue for an indefinite period. The design of our craft at

⁶ Edward S. Miller, *War Plan Orange: The U.S. Strategy to Defeat Japan, 1897-1945* (Annapolis: Naval Institute Press, 1991), 1-38. Miller effectively rebuts the view that interwar American war plans did not contribute significantly to the war effort.

⁷ As noted earlier, 20 knots was wishful thinking; had it been built it would have struggled to make 18.

present should be such as to meet the conditions that will exist in a Pacific campaign. Among these conditions are: (a) great distances and (b) lack of repair facilities. This requires in the design: (a) Great cruising radius, (b) Rugged design of machinery, (c) Habitability, and (d) Excess storage of supplies and ammunition.” Furthermore: “It would, under normal conditions, be preferable to use these submarines to make long cruises in enemy waters, in order to act as scouts, to attack enemy naval vessels when opportunity offers, and to prevent enemy trade to the greatest degree possible. Such an economic blockade would probably be the only way in which we could exert decisive pressure upon the enemy and force the fleet action.”⁸ These estimations were remarkably accurate predictions of the future role of the navy’s submarines, and they also signaled to line officers who foresaw an independent role for submarines that they had allies in War Plans. But the discussion before the board moved in circles as the old fleet boat advocates (mostly the admirals on the board) and the submarine officers, led by Captain Thomas Hart, argued about the proper role of the submarine.

After patiently listening for over an hour, a young submarine veteran tried to break the deadlock. Lieutenant Commander George Rood, who had been one of Hart’s submarine commanders in Bantry Bay, offered his perspective of the submarine needed to cover the vast expanse of the Pacific.⁹ Rood opened by saying “I have thought a little about fleet submarines, but I have not gone about it from the same point of view.” He continued, “I have gone on the basis of developing an entirely new submarine [rather

⁸ HGB, Reel 3, “Building Program 1919 – Fleet Submarine Preliminary Design,” January 30, 1920, frames 135-37. The “fleet action” he refers to is the hallowed battleship duel.

⁹ As a lieutenant during the war, Rood commanded L-1, operating out of Bantry Bay, and he was one of the first Americans to attack a U-boat. On May 22, 1918, L-1 fired two torpedoes at a U-boat at a range of 800 yards, but the bow of the American boat broached after the torpedoes were launched (not an uncommon problem then) and the U-boat commander was able to dodge the attack. See Cope, “U.S. Submarines in the War Zone,” 712.

than the fleet boat concept]. It would be called, for instance, a submarine cruiser. Now, the purpose I considered such a boat to be used for would be, say, to leave its base, unattended on an independent mission. The mission would be to lie off the enemy's ports and sink what shipping she could. We don't know what kind it will be, whether merchantmen or men-of-war." Rood continued uninterrupted for several minutes. He sketched out a boat of 1500-2000 tons, no larger (1500 tons was the size of the Second World War fleet boat) and he also predicted the torpedo tube arrangement of the future fleet boat:

The English built some submarines with six bow tubes. I saw these tubes and the vessels they were mounted in. They didn't seem to offer any very great structural difficulties and while they will destroy the lines somewhat in this vessel, we don't care much. Take those tubes instead of our customary four because, without increasing the difficulties of construction much, it is possible to get the extra two tubes which will allow a more dangerous salvo to be fired at an enemy and will allow more room for torpedo stowage. I took four stern tubes, if possible – if not, two stern tubes.¹⁰

Rood's vision was nothing less than the archetype of the American submarines that emerged in the mid-1930s. Though various cruiser concepts had been studied for several years, this was the first time the concept had been given credence in a formal board hearing. The board asked Rood to present his ideas in writing, and another meeting was scheduled to explore them. The board also requested that Captain Hart prepare characteristics for two submarines that would meet the intent of Rood's scheme.¹¹

Five days later Hart laid out two concepts before the board for discussion. Scheme A was a 2150-ton boat with 18.5 knots top speed, and Scheme B was a 2000-ton vessel

¹⁰ HGB, Reel 3, "Building Program 1919 – Fleet Submarine Preliminary Design," January 30, 1920, frames 160-63.

¹¹ Normally studies like this one were prepared by BUENG. But the manning at BUENG was a little thin at this time, and Hart was considered the leading submarine expert; he also had Nimitz on his staff, who had the necessary diesel expertise.

with a 17.1 knot top speed.¹² Both had a range of 20,000 miles at a nine-knot cruising speed and provisions to deploy for ninety days. In this hearing a lively discussion ensued and more support was offered for Rood's submarine cruiser. Captain Hart argued that "the submarine of the approximate characteristics we submit, it seems, is the only thing – absolutely the only thing, – that we could use to in any way damage that Oriental enemy in his own waters" Commander Wright added that "my idea is that the conclusions arrived at from those war plans is [*sic*] that our bases in the Pacific will probably be lost in the early part of the war. I think it is very desirable myself to have long radius cruising and blockading submarines with a secondary mission as that as fleet submarine."

Lieutenant Commander Abbot added that "it appears from the war plans that the only offensive action we could take against Japan for a considerable time after the beginning of a war would be to carry on a submarine blockade, *which would be very similar to the blockade the Germans carried on against England*. If we are to carry on such a war, we need submarines of the type which is best qualified for this service."¹³ The highlighted phrase is about as close as officers ever came to advocating all-out commerce warfare, on the record. This was understandably a very delicate subject. Nevertheless, the ideas for the Second World War fleet boat and the future commerce war were established at an early stage in development, at least in the minds of submarine officers.

¹² The relatively large displacement of Hart's options might seem curious considering Hart's preference for smaller boats. The high displacement was partially due to the erroneous impression that a cruiser designed for the Pacific Ocean mission would require an operating range of at least 20,000 miles. The fleet submarines that eventually deployed for war in the Pacific would actually have a range on the order of 12,000 miles.

¹³ HGB, Reel 3, "Preliminary Design of Fleet Submarines; Building Program, 1919," February 4, 1920, frames 164-85, emphasis added.

For all their differences, submarine operators, the War Plans Division, and the technical bureaus could all agree on one thing: they saw no future for a submarine designed to accompany the battle fleet. They collectively urged the General Board to limit the large fleet boat experiment to the first three of the nine boats under consideration. They wanted the last six to be cruisers to fulfill their vision of the future independent submarine mission. One of Hart's aids urged him to recommend making all nine cruisers, but Hart probably felt that was too bold.¹⁴ The General Board, laden with battleship admirals at this stage, was still wedded to the fleet concept. Some board members no doubt hoped that a large hull design could be perfected while diesel technology improved, thus giving them the opportunity to create a viable fleet type at some point in the future.

After the February hearings, Hart began to regret the concession to build even three fleet submarines. Future appropriations would be paltry and this might be the last opportunity for many years to develop a cruiser design. The Submarine Section compiled supporting arguments and through the CNO formally requested that the General Board reconsider and make all nine submarines of cruiser types. But the board could not be persuaded. In its final ruling the senior member stated that it "could not admit that the expediency of building [smaller cruiser submarines] . . . justifies in any degree the suggestion of the Submarine Section that the [Navy] Department would do well to break an implied agreement with Congress."¹⁵ In its decision ultimately forwarded to

¹⁴ RG 80/GB, memorandum to Thomas Hart from Lieutenant Commander L. F. Reifsnider, subject: "Characteristics Suggested for Proposed Type of Submarines," 19 January 1920, File 420-15, 1918-1920.

¹⁵ RG 80/SECNAV, memorandum from the General Board to the Secretary of the Navy, subject: "Design for Fleet Submarines," June 19, 1920, File PD-123-3, 1919-1920.

Congress, the board dismissed Hart's advice and officially recommended staying with the plan to build six fleet types and three cruiser types.

At least the submariners had gained a toehold. Due to the post-war political and economic environment, the V-class boats were constructed at a snail's pace and five separate "classes" emerged for the nine boats. These were the only U.S. Navy submarines authorized between 1919 and 1933.¹⁶

¹⁶ See appendix A for characteristics of the V-class submarines as well as other American submarines designed between the world wars.

CHAPTER VI

“PERFECTLY RELIABLE” ENGINES

TECHNOLOGICAL LIMITS

In 1921, an issue emerged that would overshadow strategy debates for a long time to come. For all of the new boats under development, navy engineers based their calculations and expectations on the latest generations of diesel engines currently being installed in the U.S. Navy’s obsolete submarines. At this time there were only two suppliers that could meet the unique requirements for submarine engines, the St. Louis-based Busch-Sulzer Company and the New London Ship and Engine Company (Nelseco), a subsidiary of the Electric Boat Company (EB). Although the engines had not been performing as well as desired, the engineers believed that their design problems could be resolved. BUENG chief Rear Admiral Charles W. Dyson was optimistic in remarks before the General Board that year: “We can give you Diesel engines absolutely reliable up to 1000 horse power per engine and of course whether we can get 20 knots depends on the characteristics of the boat We consider the engines perfectly reliable.”¹ Dyson was one of the world’s leading propeller designers and did not have a particularly strong background in engines, so he undoubtedly relied on his staff to make this ill-advised guarantee. His engineers had not foreseen it, but the navy’s S-class submarines then joining the fleet soon began to suffer chronic engine problems. Operators experienced piston failures, cylinder head cracking, broken crankshafts, and

¹ HGB, Reel 3, “Characteristics of Fleet Submarines,” February 17, 1919, frame 125.

vibration problems that were literally shaking some engines apart. Nelseco was producing particularly poor products, but Busch-Sulzer had its share of problems too.²

With dozens of competent diesel engine builders in the United States by then, one should wonder why the navy could find only two suppliers. And why were the engine designs of those two so marginal? Moreover, why did the Germans not have similar problems in their U-boats? The answers to those questions lay in the precarious state of diesel engine technology.

Submarines of this time owed their existence as practical warships to the invention of the diesel process. Before the diesel engine was invented, many submarines were built with gasoline engines, but this proved to be entirely impractical in the enclosed environment of the submarine, due to the volatility of gasoline. It was impossible to seal a submarine interior reliably against gasoline vapors, as those who sailed in such boats found out the hard way.³ The steam submarine was also infeasible, as the British learned with the K class, at least until the advent of nuclear power plants in the 1950s. Other propulsion plant processes were also considered, but none would become practical until the 1940s. The most famous alternate process was Hellmuth Walter's hydrogen peroxide combustion process, which was used by the Germans too late in the Second World War to make a difference.⁴

² Weir, *Building American Submarines*, 85-111. Weir and John D. Alden have both explored issues surrounding these diesel engines; see their works referenced herein for more information.

³ Chester W. Nimitz, "Military Value and Tactics of Modern Submarines," *United States Naval Institute Proceedings* 88 (December 1912): 1196-97.

⁴ The Germans used Walter's process in the Type XVII, the Type XXI, and the Type XXIII. Thanks to this process and the adoption of streamlined hulls, these warships operated as the world's first true submarines, i.e., vessels with air independent propulsion that could operate underwater continuously. See Ulrich Gabler, *Submarine Design* (Koblenz: Bernard & Graefe Verlag, 1986).

Rudolph Diesel had little interest in war machines. He was a classical scientist-engineer who believed that the key to invention was the mastery of the mathematical and physical theory that lies behind nature.⁵ In his early studies he was appalled to learn that the steam engine, the very keystone of the industrial revolution, was outrageously inefficient. A steam engine in Diesel's youth typically returned between 6% and 10% of the energy provided to it in heat. Early internal combustion engines were better, but still struggled to meet an efficiency of 30%. This inspired Diesel. By a thorough study of thermodynamic cycles, he invented and patented the process that bears his name, generally first credited to him by a paper he published in 1893.⁶ That year he also signed agreements with *Maschinenfabrik Augsburg-Nürnberg* (MAN) and the *Friedrich Krupp Werke* at Essen for domestic rights to his engines, but he retained international license rights for himself.

A good example of Diesel's theoretical bent is the fact that his heat engine grew out of patents he developed that led to significant advances in refrigeration. He referred to himself as an "iceman" long before he entered the diesel engine business. As his biographer has pointed out, Diesel liked to remind people that "cold is merely a degree of

⁵ It is revealing to contrast Diesel with an American contemporary, Thomas Edison. When Diesel stayed with Edison for a few days in 1912, he was shocked to learn how disdainful Edison was of higher mathematics, physics, philosophy, and the arts. According to Diesel, Edison's sole interest was in whether a device could be employed in a practical manner. See Robert W. Nitske and Charles Morrow Wilson, *Rudolph Diesel: Pioneer of the Age of Power* (Norman: University of Oklahoma Press, 1965), 231-34.

⁶ The paper was entitled "Theory and Construction of a Rational Heat Engine to Replace the Steam Engines and the Currently Known Combustion Engines." It was rather a dry title, but one containing enormous implications. For a basic discussion of thermodynamic cycles, see United States Navy Department, Bureau of Naval Personnel, *Submarine Main Propulsion Diesels, NavPers 16161* (June 1946). Available [Online]: <<http://www.maritime.org/fleetsub/diesel/index.htm>> [April 2, 2002].

classification of heat. . . . [and that] ice-making was but one demonstration of the useful developments possible through the mechanical compression of gasses.”⁷

The key to the success of his new process was that air introduced in the engine’s cylinders was heated to temperatures radically higher than previously used, approximately 1000 degrees Fahrenheit. To accomplish that goal, the air was compressed to pressures that were two to three times the pressures used in other internal combustion engines. This also allowed the use of much less refined (and less volatile) fuel because the higher pressures were sufficient to burn the cruder fuel without an ignition device such as a spark plug. The exceptionally high temperatures and pressures resulted in the extraction of more energy from the fuel and, hence, a more efficient combustion process. The engine’s high thermal efficiency and ability to burn cheaper fuel made it the most economical industrial engine available, provided manufacturing and maintenance costs could be contained.

The potential of the diesel engine focused an international spotlight on Rudolph Diesel. Adolphus Busch, the St. Louis beer magnate, signed the first American licensing deal with Diesel in 1897. However, Busch was never able to market the engines at a profit so in 1911 he formed the Busch-Sulzer Diesel Engine Company by merging with Sulzer Brothers, Ltd., the exclusive Swiss licensee of Diesel’s engines. Sulzer had a close relationship with MAN, the more important of Diesel’s two German licensees. This is significant because MAN was the worldwide technical leader in diesel manufacturing from the outset, initially due to Diesel’s decision to form a partnership with MAN. By 1914 Nelseco had also benefited from licenses with Diesel, and in that year Nelseco actually produced the largest diesel engine installation in the world, a plant

⁷ Nitske and Wilson, *Rudolph Diesel*, 72-91.

with two 2600-horsepower engines in the oiler *Maumee*, a project that diesel expert Chester Nimitz was charged to oversee.⁸ By the close of the Great War, there were over a dozen diesel engine manufacturers in the United States, but as stated above, only Busch-Sulzer and Nelseco engines were being ordered for American submarines. Returning to the original question then, why was this the case?

The problem with diesel engine design in 1921 was that it was up against the limits of contemporary engineering capability, particularly in metallurgy and vibration. In order to achieve the combustion efficiency envisioned by Rudolph Diesel, very high compression ratios were required to heat the air supplied to the engine. These pressures exerted great strain on the engines' constituent parts, which led to a number of premature failures. Simply put, metal forming and processing capabilities of the day could not produce the shapes needed with sufficient strength, ductility, and temperature and corrosion resistance. These problems spawned worldwide investment in metallurgy, and diesel engine progress remained closely tied to such improvements. Additionally, optimizing performance required that a number of new features be adopted, such as fuel injection, air compressors, and advanced lubrication and cooling techniques to dissipate the great heat generated by the diesel process. To complicate matters further, engine designers were at the same time weighing a number of significant variations such as four-stroke versus two-stroke, and single-acting versus double-acting engine cycles.⁹ Even

⁸ *Ibid.*, 26-37, 124-43; E. B. Potter, *Nimitz* (Annapolis: Naval Institute Press, 1976), 122-34. After serving on the *Maumee* before and during the war, in late 1917, Commander Nimitz decided to abandon his career as an engineering specialist and instead pursue the goal of obtaining the highest possible fleet command. Nimitz, of course, went on to lead the Central Pacific offensive of the Second World War. In 1915, Busch-Sulzer tried to hire Nimitz away from the navy, reportedly offering him a \$25,000 salary and a lengthy contract; he was making less than \$300 a month as a lieutenant at the time.

⁹ The number before the term "stroke" designates the number of piston strokes required to produce a single stroke powered by the combustion of fuel. Though two-stroke engines have higher power density

after a successful design had been devised and constructed, the engines required very careful grooming and maintenance. In most diesel applications engineers employed high factors of safety to combat these difficulties, but, as a result, the engines were very heavy. The limited space in submarines, however, dictated engines of exceptionally high power density.¹⁰ Something on the order of 20 to 60 pounds per horsepower was needed, whereas most successful diesel engines weighed over 200 pounds per horsepower.¹¹ For most manufacturers, that was simply beyond their capability.

The reason that submarine engines had to be so light was tied to the vessel's unique function and arrangement. For any ship, the overall size of the vessel obviously affects the choice of propulsion engines. The larger the ship's displacement, the larger the propulsion engines must be to move it at a given speed. However, submarine naval architects faced a number of unique constraints. First, the submarine pressure hull (or inner hull) had to be large enough to accommodate internal torpedo rooms and batteries, neither of which was required on surface ships. Moreover, the pressure hull form which could best resist the forces encountered in ocean depths was a stiffened cylinder, so all internal equipment had to be arranged within that confined shape. However, a cylindrical

than four-stroke engines, it is not higher by a factor of two, as might be reasonably assumed. The efficiency of combustion in a two-stroke engine is lower because so many process steps are fit into so short of a time interval. Double-acting engines were designed to expose pistons to combustion on both sides, which reduced the number of engine parts.

¹⁰ Power density is the ratio of engine weight to horsepower produced, the lower, the better. For an excellent discussion of circa 1920s diesel engine technology, see David Louis Jones, *Diesel Engines, Marine-Locomotive-Stationary: A Practical Treatise on the Principle, Construction, Operation, and Maintenance of the Diesel Oil Engine, both Marine and Stationary Types, with a Descriptive Chapter on the Latest Developments in Diesel Locomotives and Diesel Electric Drive for Ship Propulsion* (New York: Norman W. Henley Publishing Company, 1926), 358-83.

¹¹ For an extensive tabulation of diesel engines in the world in 1927, see O. D. Trieber, "Modern Trend of the Diesel Engine with Respect to Low Weight Per Horsepower, High Revolutions Per Minute and High Mean Effective Pressure," *The Society of Naval Architects and Marine Engineers Proceedings* 37 (November 1927): 235-57. Characteristics of about fifty engines are presented; most had weight-per-horsepower values between 200 and 350.

shape is very inefficient for surface running, where submarines spent the vast majority of their time, so naval architects fashioned a non-pressure (outer) hull around the cylinder to approximate the lines of a surface ship.¹² This gave, at best, a mediocre hull form that was inevitably less efficient than the form of a surface ship when cutting through the water. Additionally, the outer hull had to include volume for the tanks used to dive, surface, and trim the boat, as well as fuel tanks large enough to carry relatively high quantities of diesel fuel (since refueling at sea was far more impractical for submarines than for surface ships). Large fuel tanks were particularly important for American naval constructors, as it was initially estimated that a range of up to 20,000 miles might be required for future Pacific missions. These unique requirements greatly increased the volume of the vessel shape being pushed through the water, which robbed a significant portion of the engines' output power. All of these factors conspired to force designers to fit their engines into spaces that were far more confined than those of their surface ship counterparts.¹³

These inherent limitations of naval architecture explain why it was so impractical to develop submarines that could move at speeds anywhere close to the speeds of surface warships. The tight quarters also forced engine designers and naval architects to minimize the access space around the machinery, which made it even more difficult for

¹² It was futile to optimize for submerged running since the best underwater speed that could be attained was about 10 to 12 knots and the tradeoffs required to achieve those speeds (such as streamlined decks and conning towers) would render the vessel un-seaworthy on the surface, where it had to spend most of its time. The early American S-class boats were a case in point. They were able to achieve about 12 knots underwater by accepting these tradeoffs, but the vessels were poor sea-keeping vessels on the surface as a result.

¹³ Harold E. Saunders, *Hydrodynamics in Ship Design* (New York: The Society of Naval Architects and Marine Engineers, 1957), 809-14; Gabler, *Submarine Design*; Norman Friedman, *Submarine Design and Development* (Annapolis: Naval Institute Press, 1984), 17-52.

crewmen to monitor, maintain, and repair the engines. Coupled with the unhealthy atmosphere in a submarine, this made proper maintenance and repair of engines difficult at best.

Because of the marginal state of the art, the success of diesel engines required special care from not only talented technicians and engineers, but scientists as well. Diesel and his associates at MAN understood this; they took a very conservative approach to engine development and held research and development in high regard. Engines were not released to customers until they had been carefully constructed and tested.¹⁴ In contrast, the evidence suggests that the American companies simply did not make the required investment in science and technology.

THE LINE OFFICERS REBEL

As the fleet struggled with its engine problems, a former submarine commander decided to take matters into his own hands. The irascible Yates Stirling penned a blistering critique of the situation, which he sent directly to the Secretary of the Navy, Edwin Denby.¹⁵ Then a captain serving as commandant of the Philadelphia Navy Yard, Stirling's letter addressed the state of submarines in general, and diesel technology in particular. By then, senior commanders were well aware of Stirling's reputation. After witnessing the poor condition of submarines when he took over command of the Atlantic Submarine Flotilla in 1914, then-Commander Stirling wrote a letter to the Navy Department citing the submarines' shortcomings and advancing his ideas for unifying the command of all submarine activities, which he called the principle of "undivided

¹⁴ Nitske and Wilson, *Rudolph Diesel*, 83-144.

¹⁵ Recall that Stirling was long a vocal critic of Navy Department organization.

control.” The letter created such a stir that a congressional committee was formed to investigate. According to Stirling, Admiral Winterhalter, a senior member of the General Board, tried to force him to alter his testimony prior to the hearings. But Stirling would not be intimidated, and he said his piece in the two days of hearings. His effort was futile because his proposal was simply used by the partisans on the committee to advance party agendas. Stirling learned that he had unwittingly become a pawn in the battle that Secretary of the Navy Josephus Daniels and his aide for operations, Bradley Fiske, were engaged in over creation of the office of CNO (see Chapter III). Fiske’s allies (the Democrats on the committee) claimed the issue was a barometer of the poor state of the navy while Daniels’s allies (the Republicans on the committee) insisted that all was well. In the end Stirling walked away with a public reprimand from Daniels, and his ideas for improvements were mostly ignored. Though he remained in his post until 1917, he further infuriated senior leadership by refusing to send his submarines overseas in 1917 before they were fit to make the trip (see Chapter IV). A few months before they left, he was transferred, and after three years as a leading submarine commander, he was given the command of a troop transport when he received his sailing orders for Europe. So, perhaps not all dissent within the navy ranks was free from retribution, but Stirling was persistent.¹⁶

In his 1921 letter, Stirling continued to hammer away at the Navy Department with his principle of undivided control. He argued for the formation of a Bureau of Submarines (BUSUBS) analogous to the Bureau of Aeronautics (BUAIR) formed that same year to administer naval aviation activities. In a submarine bureau, he reasoned,

¹⁶ Yates Stirling, *Sea Duty: The Memoirs of a Fighting Admiral* (New York: G. P. Putnam’s Sons, 1939), 154-65.

submarine specialists could focus on their unique product and not be constantly relegated to the background behind the more glamorous surface ships. His letter prompted special hearings of the General Board at which he was called to testify.

This time he was more prepared than he had been before Congress in 1914. Before the hearings, he solicited comments on his letter from ten submarine and engine authorities, including Captain Hart and future submarine commander Charles A. Lockwood, Jr. All except Hart held only the rank of lieutenant commander, but all had operating experience in submarines or with diesel engines. The officers generally supported Stirling, though some were not as strident as he. The officers seized the opportunity to laud the U-boat designs and criticize BUC&R for not taking more lessons from the Germans. Captain Hart was unrestrained in his reply to Stirling: "I am entirely willing to be quoted. I wanted to leave the submarine service because of the state of mind that over five years of this struggle to do things with submarines had gotten me into. One thing that had much to do with chafing my bark down to the raw was the continual fighting to beg, cajole and force the material Bureaus into learning something from the ex-German submarines. It took months of work to get permission to bring them over here in the first place."¹⁷

As discussed earlier, BUC&R was much less enthusiastic about the U-boats than was Hart or the other operators. BUC&R also provided evidence in the hearings that it had made some design changes as a result of studying the U-boats which the operators

¹⁷ HGB, Reel 4, "Situation Relative to Submarines," June 30, 1921, frames 304-55; "Situation Relative to Submarines," July 1, 1921, frames 356-85. Partly due to his frustration over the "bickering and gloom" of Washington, at his request Hart was transferred to submarine sea duty in 1920, where he was still assigned at the time of this hearing. Hart was also frustrated at the number of officers that were leaving the navy for more lucrative offers in private enterprise. Regarding the tart nature of his comment, Hart noted "I can not be hated [by some bureau engineers and General Board members] any worse than is already the case." See Leutze, *A Different Kind of Victory*, 65-73.

were not yet aware of, but these were minor in nature.¹⁸ BUC&R also claimed that it had obtained and studied drawings of three German submarines, which Stirling had also not known prior to sending his letter, but this point was misleading. BUC&R had obtained a few blueprints of some German designs, but it is doubtful that the naval constructors had anything close to the amount of data that would be required to build or fully understand the process for building any of the German boats.¹⁹

Despite his preparations, Stirling's proposal was doomed from the start. Although his plan was technically sound, in the eyes of the bureaus it was nothing more than a new flanking maneuver against an old foe. The line officers had been struggling with the bureaus for control of ship design for decades. To endorse Stirling's proposal would require establishing a bureau chief who would probably have to be a line officer (someone like Hart perhaps) and who would have veto power over the powerful BUC&R. Bureau chiefs were not known for relinquishing power quite so readily.

In the end, the General Board diffused the issue by blaming the engine problems on over-dependence on EB. This was a clever maneuver. It provided a minor concession to the line officers, since the shipbuilder had made as many enemies in the fleet as it had made friends in Congress. At the same time it served the interests of everyone in the navy, in that the obvious solution to dependence on a commercial shipyard was to develop submarine building expertise at government yards. Spreading the few submarine contracts so thin did not come without risk. EB almost went out of business before naval

¹⁸ Gary E. Weir, "The Search for an American Submarine Strategy and Design, 1916-1936," *Naval War College Review* 44 (Winter 1991): 36-39.

¹⁹ It is estimated that at least one thousand drawings would have been required to build a typical U-boat. This is based on the author's experience as a submarine design engineer and the fact that approximately eight to nine thousand drawings were required for capital ships of the Second World War. See McBride, *Technological Change*, 195.

rearmament got underway in 1933. But it survived and the competition between EB and navy design agencies ultimately helped produce better submarine designs.

Stirling did not get his coveted unified command (BUSUBS), but he probably accomplished all that he could have under the circumstances. In addition to the political hurdles noted above, it became clear during the hearings that such an organization would be difficult to staff. There were already too few experts to go around in the technical bureaus and a hiring spree was unlikely in an age of disarmament. Also, the navy was already going to have a difficult time setting up its new aeronautics bureau, and BUAIR was vitally needed to exploit the rising efficiency of aircraft and to fight the U.S. Army Air Corps for ownership of future air missions. Priorities had to be set. But there were some meaningful concessions, as can be seen from the following excerpts from the board's final recommendations to the Secretary of the Navy on the matter:

In their endorsements [to this letter] the material Bureaus acknowledge the unsatisfactory status of certain features and state their intention to substitute either new designs originating in the Bureaus or copies taken direct from the German submarines

In view of the S-boat situation and history of submarine construction . . . the government should no longer permit a situation to continue which virtually places submarine design and construction in this country at the mercy of a few firms who practically hold a monopoly [read EB]. The General Board strongly urges that the Navy Department itself take up the design of submarines for our Navy. . . .

We should not hesitate to copy every feature that shows superiority of design and performance that is obtainable either from Germany or [any] other source. . . .

The General Board therefore recommends: . . .

That a special Navy plant on each coast be equipped for submarine work and that all repairs and government construction be carried on at these plants [Portsmouth Naval Shipyard and Mare Island Naval Shipyard].

That an organization of skilled mechanics be maintained at each plant for work on machinery of submarines.

That a practical school of instruction be maintained at each plant for enlisted men for submarines.

That special attention be given to the selection of personnel, officers, and men for submarine service and that as far as practicable they pass through the schools at the plants or at New London [Submarine Base].²⁰

²⁰ RG 80/SECNAV, letter from the General Board to the Secretary of the Navy, subject: "Situation Relative to Submarines," July 25, 1921, File PD-123-3, 1921-1922.

Thus, Stirling did extract formal recognition of the value of the German model, expansion of navy design and building expertise in submarines, and improvements for submarine personnel.

Unlike BUC&R, BUENG did not need to be persuaded to seek lessons from foreign designs. In 1919 the bureau began funding a diesel research and development center at the New York Navy Yard (NYNY), alongside a material research activity already in place. The bureau had concluded on its own that it could not rely solely on American engine makers, though it recognized that industry must still be engaged. BUENG dismantled the machinery from all the U-boats that the navy had acquired (except U-111) and installed the equipment in its shore-based facilities at the NYNY and its other major laboratory, the Annapolis Engineering Experiment Station. Although contractors such as Nelseco and Busch-Sulzer were invited to observe and inspect the German diesels, the main purpose of this effort was to develop an independent engine expertise at NYNY, much as shipbuilding expertise would later be developed at Portsmouth and Mare Island. With the German engines in hand, NYNY disassembled, examined, and copied them as a starting point for future development. The result was a series of designs known as the Bu-MAN engines, which were used in the bulk of the V-class boats.²¹

The bureau engineers also realized that something had to be done to advance American material science capability. BUENG started by funding NYNY to research developments in metallurgy, centrifugal casting, and other metal forming techniques. As discussed above, many of the engine problems encountered were related to the final form of the material. Copying the dimensions of parts is relatively easy, but replicating

²¹ John D. Alden, "Development of the High-Speed Diesel Engine for United States Submarines," *Naval Engineers Journal* 91 (August 1979): 43-49.

materials is not quite so straightforward. Chemical composition can be reliably determined, but composition is only the starting point for material design. Final properties are highly process-dependant, especially when devising materials that push the limits of contemporary science. Welding, casting, forging, and heat-treating processes all had to be established by trial and error, and American capabilities at the time were generally inferior to German practices, although that gap evaporated in the 1930s.

The BUENG investments were well conceived, for, by the end of the decade, the navy was dependent solely on the Bu-MAN engines for submarines. Due to slim budgets and the low priority of submarines in the 1920s, the commercial companies received few government orders, and the Great Depression made matters worse. By 1929, EB permanently closed its Nelseco operations and Busch-Sulzer decided the tiny segment of its business dedicated to these small, troublesome engines was no longer worth the resources expended.²²

²² Wier, *Building American Submarines*, 85-112.

CHAPTER VII

ELECTRIC SHIPS

A major paradigm of submarine design in the early twentieth century was the propulsion machinery layout known as direct drive, and it was this arrangement that was the major culprit behind the vibration problems that afflicted early American submarines. There were two basic versions of direct drive, one with and one without reduction gears. In a diesel-direct drive layout (DDD, see fig. 2) the propulsion engines were linked directly to the propeller shafts by couplings and clutches. When reduction gears were introduced, the arrangement was called diesel-reduction gear-direct drive, or DRD.¹ In both arrangements, the engines are run through a wide range of speeds in order to produce the desired propeller revolutions per minute (rpm) and corresponding ship speed. However, in every complex mechanical system like a diesel engine there are several critical speeds at which system resonance can occur. While resonating, a system experiences mild to severe self-shaking that can drastically reduce performance and the useful life of its parts. For successful operation, critical speeds must either be avoided or engineers must devise ways to damp vibration at those speeds.

Although this vibration phenomenon was well understood by engine designers, naval architects and marine engineers either did not fully appreciate it or they were unable to account for it. Integration of a direct-drive engine in a ship produced a much

¹ Reduction gearing was introduced between engines and the propeller shafts in some cases to reduce the output speed of the propellers. This was done to resolve the basic dilemma posed by the fact that engines operated most efficiently at relatively high speeds, whereas propellers operated most efficiently at relatively low speeds. A drawback of reduction gears at this time is that they were inefficient and loud. Noise made the ship easier to detect with underwater listening devices, and it created a more difficult operating environment for the sailors that tended the machinery.

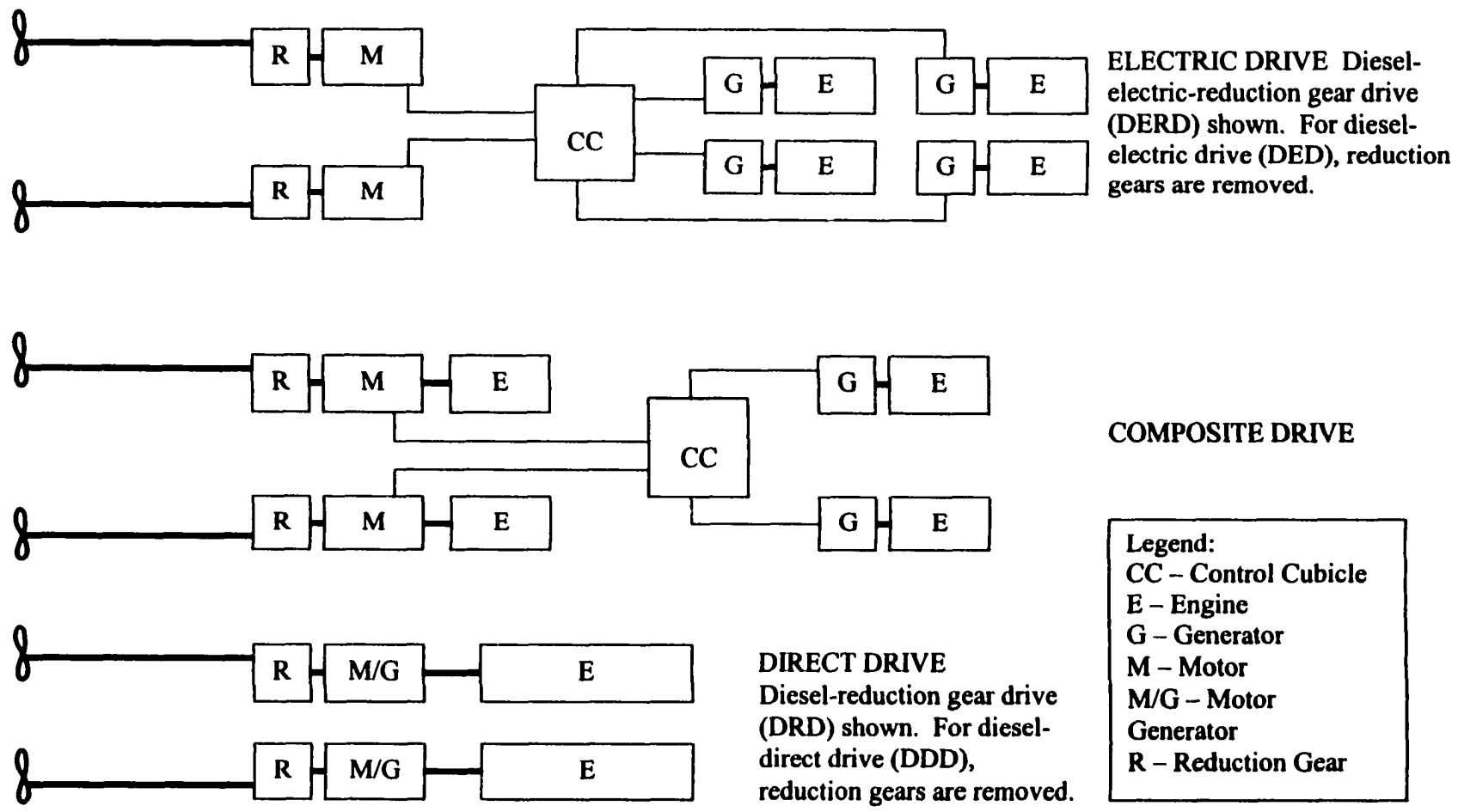

Fig. 2. Schematic Diagrams of Propulsion Plant Arrangements. Heavy lines indicate a mechanical connection; lighter lines indicate an electrical connection. Batteries and associated electrical gear are not shown for clarity; they would be similar for all arrangements. Clutches, couplings, and miscellaneous electrical gear are also omitted for clarity. Information in this figure is developed from Alden, *The Fleet Submarine*.

larger vibration system, including the propeller shafts, couplings, and clutches, as well as the foundations and ship structure. These elements all conspired to produce additional critical speeds or exacerbate existing ones. As a result, engines could be tested and evaluated on test stands, but until they were operating as part of a shipboard system at sea, their “real-life” performance was not completely revealed.² Vibration concerns were so intrinsic to the early U.S. Navy throttlers’ training that large brass plaques were posted in the engine rooms listing the critical rpm ranges to avoid whenever possible.³ Engines and driveshaft parts designed for surface ships and most other industrial applications could simply be made large and heavy enough that they would either not experience resonance or they would not fatigue prematurely if they did. However, as discussed in Chapter VI, submarine designers did not have that luxury, since heavier engines were impossible to tolerate in a vessel that was already operating below its desired speed.

The vibration problems inherent in direct drive systems, or, more correctly, the engineers’ inability to correct them, prompted bureau engineers to study an intriguing propulsion alternative known as electric drive. An electric drive system used the propulsion engines as generators to develop direct current (DC) electricity. The current was used to drive electric motors for surface propulsion, just as had always been done in submarines for submerged propulsion, with batteries as the source of electricity. However, this required dedicated generators, larger motors, and an array of electrical gear

² To further complicate matters, shipboard propulsion systems span large areas that are subject to variable forces and deflections as the ship rides over, through, and under the seas that the vessel encounters. The forces acting on the system are also subject to change as clearances between parts change under use.

³ Harold G. Bowen, *Ships, Machinery, and Mossbacks: The Autobiography of a Naval Engineer* (Princeton, NJ: Princeton University Press, 1954), 127-28.

not needed in a conventional direct drive.⁴ The chief advantage of electric drive was that it allowed the engines to be run at a conveniently chosen constant speed, thereby avoiding resonant speeds except at startup and shutdown. It also provided the naval architect more arrangement flexibility since the engines did not have to be aligned with the propulsion shafts. However, the tradeoff was higher weight and lower efficiency because more components were required, more space was needed to arrange them, and the source power was transformed through more electro-mechanical interfaces. Almost all early electric-drive installations also employed reduction gearing because, like many diesel and steam engines, electric motors could not be designed to operate efficiently at low speeds. This introduced yet another efficiency loss and another weight and arrangement penalty.⁵

By the late 1920s, the use of electric drive on U.S. Navy surface ships had been through two decades of high-visibility controversy. It was originally proposed for battleships in 1908, using steam turbines as the prime mover instead of diesels.⁶ Electric drive was then touted as a more efficient alternative to reduction gear drives or direct-connected engines. It was a hard sell in the conservative navy, so the General Board insisted it be tried in a collier first. The board went a step further by arranging a competition among three different drives on three separate colliers in the 1911

⁴ Direct-drive systems used the motors as generators while the engines powered the ship on the surface. This was not an option in an electric-drive system because motors were always in use to propel the ship. Hence, dedicated generators were required.

⁵ Such systems were called diesel-electric-reduction gear drives (DERD).

⁶ After the British installed turbo-electric drive in HMS *Dreadnought*, some American battleship admirals feared that the British would gain an edge over the Americans in the all-important battleship technology. See McBride, *Technological Change*, 71-77.

shipbuilding program, and the electric-drive system won handily in the *Jupiter*.⁷ The *Jupiter*'s talented chief engineer, Lieutenant Samuel Robinson, reported that the turbo-electric drive was easily operated by relatively unskilled sailors (always desirable), provided for accurate speed control, and most importantly, exceeded the supplier's (General Electric) guaranteed efficiency predictions by 18 percent.⁸ Robinson was an enthusiastic supporter of electric drive and no doubt relished this post to advance his expertise in this area. Already a prolific contributor to the premier naval engineering journal of the time, the *Journal of the American Society of Naval Engineers*, Robinson published the results of *Jupiter*'s trials in the journal in 1914.⁹ The *Jupiter*'s success led to selection of turbo-electric drive for all American battleships through the First World War. Robinson could not have known it at the time, but the *Jupiter* experiment would have major ramifications on American submarines some twenty years later.

Despite the success story, the foes of electric drive did all they could to derail the new technology. Private shipyards (Newport News Shipbuilding and New York Shipbuilding) and other industrial concerns that stood to lose from rejection of the other technologies launched a campaign to rally congressional and public support. Their efforts were largely unsuccessful, but, where political maneuvering failed, the progress of technology ultimately prevailed by the late 1920s. Improvements in metallurgy and gear-

⁷ The other two were a steam turbine–reduction gear drive and a diesel–direct drive. The diesel system was probably not more competitive due to the operation of the propeller at other than optimum speeds and the fact that large marine diesel technology in America in 1911 was relatively undeveloped.

⁸ The competition for battleship propulsion contracts (the ultimate goal here) was so intense that the companies involved agreed that “in case of failure of the experimental installation, the builders of this machinery would receive no payment and the entire cost of its removal, and the preparations of the foundations to receive reciprocating engines would be borne by them.” See McBride, *Technological Change*, 100.

⁹ Samuel Robinson, “Operations and Trials of the U.S. Fleet Collier *Jupiter*,” *Journal of the American Society of Naval Engineers* 26 (1914): 339-53; McBride, *Technological Change*, 98.

cutting methods swung the efficiency advantage over to reduction gear drives by 1930, where it remains for steam-driven ships to this day.¹⁰

The crucial development that made electric drive a viable option for submarine designers was the promise of high-speed diesel engines. Beginning in Germany and then spreading rapidly to the rest of the world, manufacturers began something of an international race to develop the lightest possible high-speed diesels, operating between 700 and 800 rpm, about twice the top speed of slow-speed engines used for diesel-direct systems.¹¹ Advances in metallurgy and the use of smaller pistons (and correspondingly smaller drive train parts) reduced the mass of moving parts in each cylinder, which allowed higher rotational speeds. The high-speed engines produced a linear increase in output power, since power is directly proportional to rpm. This improvement alone had the potential to halve the engine designers' crucial design criterion, pounds per unit of horsepower, which would more than offset the efficiency drawbacks of electric drive outlined above.

In the late 1920s, however, the performance of high-speed engines suitable for submarines was still too shaky. In a 1928 hearing Rear Admiral Harry Yarnell, then chief of BUENG, informed the General Board that "the development of very high speed reliable engines of light weight may make electric drive practical in these boats, but that development is believed to be somewhat removed into the future." At the same hearing, Yarnell strongly recommended that the board approve funding to motivate private manufacturers to develop the new engines, although he probably recognized there was

¹⁰ McBride, *Technological Change*, 102-10.

¹¹ Mark Reutter, "The Lost Promise of the American Railroad," *The Wilson Quarterly* 18 (Winter 1994), 11.

scant funding available at the time. He summarized the state of engine development by stating that the only adequate submarine power plants were the Bu-MAN, Busch-Sulzer, and Nelseco plants that were “designed during the war period – about 1915-1917.” He went on to say that “due largely to the absence of any new construction in submarines, no new [engine] designs have been perfected either by the Bureau or by private enterprise.” Yarnell’s assistant, Captain Ormond Cox, also pointed out that “the nearest reliable engine that we have, that the ordinary average man can handle, is the New York MAN engine copied from the German engine. I would not recommend installing any other type in a building program.”¹²

BUENG left no stone unturned in its attempts to facilitate the development of commercial engines that could be used in submarines. While the engineers were unwilling to select the early high-speed engines for the V-class boats, Yarnell solicited engine manufacturers for their interest in supplying engines for an experimental electric-drive plant to be installed in some old S-class submarines. He submitted a letter to eighteen engine companies on July 11, 1929, along with detailed plans and performance criteria. His goal was to perfect the promising new systems in a low-visibility application. If the effort was unsuccessful, at least none of the more modern boats would be adversely affected.¹³

That same year Yarnell and his engineers thoroughly probed the American engine market. BUENG was dubious about NYNY’s ability to manufacture all the navy’s slow-

¹² HGB, Reel 8, “Characteristics of Future Submarines – Recommendations,” 31 October 1928, frames 357-81.

¹³ Records of the Bureau of Ships, 1794-1972, Bureau of Engineering General Correspondence, 1923-1940, Record Group 19, National Archives Building, Washington, D.C. (hereafter RG 19), letter from H. E. Yarnell (Chief of Bureau), no subject, 11 July 1929, File SS/S41- Submarines, 1929.

speed engines should a great wartime demand appear, instead it hoped that private engine manufacturers could either develop a superior design or build to NYNY's Bu-MAN plans.¹⁴ However, the results were disappointing. As Yarnell put it, "there is no commercial firm in this country that can build as good a direct drive diesel as the MAN engine that was built at New York. It does not seem possible to get them interested in it because there is no market for that type engine in the commercial line."¹⁵

While canvassing the market, Yarnell's engineers also searched for American firms willing and able to develop a suitable high-speed engine. After meeting with numerous companies, the engineers found that the only promising commercial application for the high-speed engine was its occasional use in the railroad industry. As the bureau engineers knew, companies had been experimenting with high-speed diesels in locomotives, and, by coincidence, the space envelope available to submarine designers was about the same as in a railroad locomotive. But after an extensive survey of eight potential high-speed diesel suppliers was complete, Yarnell had to tell the General Board that "outside of switching service and for use on single branch lines, there is no evidence to indicate that railways contemplate any extended use of Diesels for locomotive service." Though several companies expressed interest, none was willing to develop the high-speed type without a guarantee that the government would cover the development cost, an unlikely prospect for the financially strapped navy of 1929. Yarnell recognized

¹⁴ HGB, Reel 8, "General Characteristics and Designs of Future Submarines," 24 September 1930, frame 407.

¹⁵ HGB, Reel 8, "Cruiser Submarines V7, V8 & V9," 18 August 1929, frames 188-93.

that the only short-term production alternative was to strengthen the NYNY program and the navy's ties with MAN.¹⁶

As luck would have it, the navy had a key engineer on assignment in Berlin. Lieutenant John Huse, the assistant naval attaché at the U.S. embassy, was an experienced submarine officer who had been through the post-graduate program at Columbia University. Due to his keen interest in both submarines and diesel power, he spent a considerable amount of time surveying European diesel manufacturers. Huse established excellent connections in MAN's Augsburg facilities, including a relationship with the company's manager, Immanuel Lauster, who had been Diesel's chief assistant until Diesel's untimely death in 1913.¹⁷ Huse was intrigued by the lightweight engines (both low- and high-speed) that were being developed by MAN, and he facilitated a three-month visit by Yarnell to Augsburg in the summer of 1930 to study MAN's post-war improvements in engine design and to discuss business arrangements.¹⁸

Yarnell then set out to acquire some funding to implement his plans. Through meetings with the General Board and Congress in 1930 and 1931, he eventually secured \$3.5 million for diesel research and development, \$500,000 of which he used to buy plans from MAN for its latest slow-speed engines.¹⁹ The remaining \$3 million was spent to expand the program at NYNY. Yarnell would have preferred that an American

¹⁶ Ibid.

¹⁷ Diesel disappeared on an ocean passage to England, where he was to open a new manufacturing facility. The circumstances surrounding his disappearance suggest that he committed suicide. See Nitske and Wilson, *Rudolph Diesel*, 235-56.

¹⁸ Alden, *The Fleet Submarine*, 20.

¹⁹ These engines became known as metric-MAN engines because the plans used dimensions in metric units.

manufacturer buy a MAN license, and the German company actively solicited such an arrangement, but MAN's price was too high to attract a domestic supplier.²⁰

In the absence of a domestic licensee, the next best thing for the navy would have been to secure a license agreement directly between BUENG and MAN. With this, Yarnell's submarine engines could have been built in Switzerland by a MAN affiliate or under MAN's supervision at NYNY, "on account of the [Versailles] Treaty," as Yarnell put it. Even if BUENG had the budget for such a license, which it did not, the political barriers to such an arrangement were probably insurmountable. Buying engines from Germany per se was not the primary concern, although the Versailles Treaty was a factor.²¹ The primary political concern was the pressure the navy believed would be applied by trade unions and congressional representatives due to the work's not being given to domestic shipyards.²²

With the new MAN designs in hand and the bleak short-term outlook for high-speed engines, Yarnell could not risk recommending electric drive in 1930. When it came time to settle on the engines for the last two V-class boats, he reported to the General Board "the stock of Diesel electric drive in my mind has now gone down and I am more or less switched back to a direct connected [slow-speed] engine." During much

²⁰ Gary E. Weir, "The Navy, Industry, and Diesel Propulsion for American Submarines, 1914-1940," *Naval Engineers Journal* 101 (May 1989): 214-15.

²¹ Article 170 of the treaty stated that "Importation into Germany of arms, munitions and war material of every kind shall be strictly prohibited. The same applies to the manufacture for, and export to, foreign countries of arms, munitions and war material of every kind." See *The Versailles Treaty* (June 28, 1919). Available [Online]: <<http://history.acusd.edu/gen/text/versaillestreaty/vercontents.html>> [March 17, 2002].

²² Private firms, navy yards, and the trade unions whose members were employed there were a nuisance to naval engineers throughout the period. Some major decisions, which had an adverse affect on one entity, would result in inquiries by Congress or the president requesting that the bureaus justify their actions. There are several instances of complaints by NYNY when it was denied business, including one where Franklin Roosevelt tried to intercede on its behalf. See RG 19, various letters, File SS/S41-Submarines, 1932, 1934, and 1937.

of that hearing, the admiral was peppered with questions by board members who were clearly intrigued by the lure of electric drive discussed in previous hearings. No doubt the withdrawal of Busch-Sulzer and (to a lesser extent) Nelseco from the submarine diesel business weighed heavily on Yarnell's mind. Near the conclusion of the hearing, Yarnell summarized his objections with a prescient observation: "When railroads adopt high speed Diesel electric drive for their fast trains and it proves successful, then we can consider high speed electric drive for submarines, and until that time arrives I am dubious whether it would be successful for submarines."²³ For the next 20 months, although BUENG continued to maintain close contact with domestic engine manufacturers, when forced to make recommendations for future boats it had no choice but to stay with the proven slow-speed engines and the DDD layout.

Despite the bureau's setbacks, by 1932 Yarnell's investments began to pay off. The lieutenant who had overseen the *Jupiter* electric-drive installation had risen rapidly in the technical ranks and, late in 1931, Rear Admiral Samuel Robinson replaced Yarnell as the chief of BUENG. Using the same tactics employed in 1929 by Yarnell, on March 7, 1932 Robinson signed a letter that initiated a high-speed engine competition that would shape the course of submarine development for over a decade.²⁴ The letter was sent to seventeen companies that had manufacturing or consulting experience with diesel engines, and this time it included financial incentives to help defray the cost of building a

²³ HGB, Reel 8, "Main Engines and Necessary Auxiliaries for the U.S.S. V-8 and U.S.S. V-9," 8 July 1930, frames 253-66. Note that he specified fast trains. Bureau engineers were by now quite familiar with the railroad industry. Locomotives were used for a variety of services including urban and intrastate passenger, freight, and rail-yard switching service among others. However, the recognized bulk of the railroad market was for hauling freight and passengers, in that order, over long distances. High-speed trains, almost all steam powered in 1930, made up the vast majority of the business.

²⁴ John D. Alden was the first author to point out the significance of this competition. See Alden, *The Fleet Submarine*, 43-5.

prototype. The bureau also apparently sent blind copies to at least four European engine manufacturers, three German and one Swiss. The bureau knew it would not be able to purchase engines directly from a German firm; Congress had made that clear. But responses from the German companies were of great interest because the bureau still hoped that a German firm might strike a licensing deal with an American manufacturer, and because they allowed the bureau to use the European companies as a qualitative measure of the American firms' capabilities.²⁵

Robinson was the proverbial right man at the right time. He was convinced of the efficacy of electric drive, partly based on his experiences on the *Jupiter*.²⁶ Drawing on the work done in the bureau under Yarnell, he established electric-drive submarines as one of the top goals of his term as bureau chief. Just as importantly, Robinson was a consensus-builder who recognized the problems caused by the fractious organization of the Navy Department. He went out of his way to make himself liked and respected among the bureaus as well as the operating forces.²⁷ He was one of those rare engineers who excelled at both the political and technical demands of his job.

When Robinson's letter went out to industry, the timing was finally right for BUENG. Companies were hungry for the work and the engines were becoming more promising each year. By the close of 1932, the bureau had five companies under contract. Among those was one of the two that became the mainstay of the American

²⁵ RG 19, various correspondence, File SS/S41- Submarines, 1932. This file contains proposals from the German companies *Deutsche Werk Kiel*, MAN, *Linke-Hoffman-Busch*, and the Swiss Brown, Boveri & Company. All refer to the March BUENG letter and the Linke letter refers to a plant visit from Lieutenant Eliot Bryant, an assistant naval attaché in Berlin.

²⁶ In 1921 the *Jupiter* was converted to the USS *Langley*, the navy's first aircraft carrier, and used for training.

²⁷ Alden, *The Fleet Submarine*, 43-44.

submarine fleet, Winton, an old engine-making firm purchased by General Motors (GM) in 1930. Although the other four firms were unsuccessful, two more companies, Fairbanks-Morse and Hooven-Owens-Rentschler (HOR) submitted satisfactory bids using their own funds.²⁸ For the next ten years, GM-Winton, Fairbanks-Morse, and HOR would compete for the navy's future submarine engine business.

²⁸ Alden, "Development of the High-Speed Diesel Engine," 44-45.

CHAPTER VIII

THE RAILROAD CONNECTION

As Yarnell had predicted before leaving BUENG, the catalyst for submarine engine development was the American railroad industry. Locomotive manufacturers had long recognized the potential of diesel-driven locomotives. In the late 1920s, though, the steam engine still dominated the railways. Three manufacturers, American Locomotive Company, Baldwin Locomotive Works, and Lima Locomotive Works held 40%, 40%, and 20% of the locomotive market, respectively, the vast majority of it in steam engines. Diesel-electric locomotives were limited to use in light switching service applications and in services where fire and smoke hazards associated with steam engines were objectionable, such as in urban areas and tunnels. Diesel engines of the day were still too heavy for the roadbeds and could not develop the necessary power or speed for prime locomotive road service (60 pounds per horsepower was the lowest typical value, whereas 20 pounds per horsepower was desired, just as in submarines).¹

The twentieth century had not been kind to the nation's railroad companies. A backlash against actual and perceived railroad abuses of the 1900s had led to a great deal of unwelcome attention from the federal government. Beginning in 1906, Congress empowered the Interstate Commerce Commission to establish "just and reasonable" rates that the railroads could charge for hauling freight. For three decades railroad costs due to operating expenses and taxes rose continuously while revenues were held down by regulation. Labor problems were rampant and the federal government even took control of the nation's railroads during the First World War in an attempt to rationalize the

¹ Marx, "The Diesel-Electric Locomotive Industry," 20-22.

system. Regulation could not have come at a worse time for the industry. Progressives pushing regulation did not account for the competition that was pressing in on the railroad business from pipelines, trucking, automobiles, barge traffic and intercity buses. The railroads did manage to modernize their systems by the time of the Great Depression, as a mild recovery was underway, but the stock market crash dealt the industry a crushing blow. Railroad company net income of \$977 million in 1929 became a loss of \$122 million by 1932. As late as 1939, bankrupt carriers were operating over 77,000 miles of track.²

The big three locomotive manufacturers had what business historians call first-mover advantages. They collectively owned the steam locomotive market and the cost of entry for a newcomer was high. First movers often dominate markets for many decades for this reason. In this environment there was not much incentive for them to change.³

In the early 1930s, two bold business ventures were formulated to exploit the plight of the American railroad industry. The first was initiated by GM's vice-president in charge of research, Charles F. Kettering, who had become very interested in the possibilities of diesel power in the 1920s. In 1930 GM purchased not only Winton, the winner of BUENG's submarine engine competition in 1932, but also Electro-Motive Company (EMC), a designer of gas-electric railcars and a rising player in the electric motor business. GM intended to capitalize on its own experience with internal-

² Keith L. Bryant, Jr., ed., *Railroads in the Age of Regulation* (New York: Facts on File Publications, 1988), xx-xxiii.

³ The antithesis of the environment that first movers enjoy is called the "attackers advantage." This becomes prominent when a new technology emerges that has the potential to be more effective than the status quo. First movers are often slow to react to such challenges due to organizational inertia. See Albert J. Churella, "Market Imperatives and Innovation Cycles: The Effects of Technological Discontinuities on the Twentieth-Century Locomotive Industry," *Business and Economic History* 27 (Winter 1998): 380.

combustion engines and, along with Winton and EMC, it intended to break into the locomotive market with diesel-electric power.⁴

Almost simultaneously, railroad entrepreneur Ralph Budd launched a bold initiative to try to invigorate the Chicago, Burlington, and Quincy Railroad. Budd took over the presidency of the ailing carrier in 1932 and immediately made a number of changes in the operations of the “Q,” as it was known. His most important contribution stemmed from his conviction that railroads must do something to reclaim the passenger business that they were losing to the nation’s highways. Even before he decided how to power it, he ordered a lightweight three-car stainless steel train from the Edward G. Budd Corporation (no relation), an automobile coach manufacturer. Ralph Budd intended to place the *Burlington Zephyr*, as the train would be called, on the Q’s important Chicago-to-Denver run.⁵

Thanks to the use of stainless steel and aluminum and the perfection of a process called “shotwelding” used to join them, when the train was complete it weighed only 219,000 pounds, as compared to about 800,000 pounds for a conventional train of the same size.⁶ But Budd wanted stainless steel and aluminum for more than their favorable strength-to-weight ratios: he wanted them for their flashy appearance. He had the designers of the coach develop a futuristic, rakish design for his new train. The locomotive had a long, sloping nose which transitioned seamlessly into the sides of the locomotive and the passenger cars. Even wind tunnel testing was conducted at MIT to

⁴ Churella, *From Steam to Diesel*, 37-74.

⁵ Albro Martin, “Ralph Budd,” in *Railroads in the Age of Regulation*, ed. Keith L. Bryant, Jr. (New York: Facts on File Publications, 1988), 56-60.

⁶ Aluminum has about one-third the density of carbon steel. The density of carbon steel and stainless steel is essentially the same, but at that time stainless steel could be formed into thinner sections than carbon steel could.

minimize aerodynamic drag at the speeds at which Budd expected to operate. Because of the materials used, the entire train was brilliant silver in color, which gave it a spectacular appearance compared to the darker trains typical of the day.⁷

Ralph Budd did not know it when he conceived the *Zephyr*, but his creation was destined to be powered by a submarine engine know as the GM-Winton 201. After winning the BUENG engine competition in 1932, the corporation began searching for new industrial applications for the high-speed engine. GM decided to put two 201s on display in the Century of Progress exhibit at the 1933 World's Fair in Chicago to generate some interest. Independently, Harold Hamilton, then president of GM's new EMC division, approached Budd about a diesel-powered train and Hamilton took Budd to the exhibit to show off the 201. Much of Hamilton's career at EMC had been in the service of railroad applications of the company's electrical equipment. Budd immediately decided to put the Winton engines in the *Zephyr*, but he had a hard time convincing GM's president, Alfred P. Sloan, Jr., to accept the risk. Sloan was afraid that there was simply too little time to develop a sufficiently reliable engine, and he knew that a failure in a high-visibility application like the *Zephyr* could undermine GM's long-term plans for going after the locomotive market. Sloan also knew what took place behind the scenes at the World's Fair exhibit. A team of engineers and mechanics had to be installed in the basement of the building, frantically performing maintenance on the 201s after hours and remaining on standby around the clock. Kettering said afterward that "the

⁷ Churella, *From Steam to Diesel*, 37-74.

only part of that engine that worked well was the dipstick.” Nevertheless, the persistent lobbying of Budd, Hamilton, and Kettering convinced Sloan to accept the challenge.⁸

The results stunned even the engine’s most ardent supporters when the *Zephyr* entered service less than one year later. On May 26, 1934, during its first day of commercial operation, it traveled from Denver to Chicago in thirteen hours and five minutes, about half the previous best time on the run, completely shattering world records for speed by rail. The train *averaged* an unheard-of 77 miles per hour. Thanks to a publicity blitz by Budd, people came out in droves to line the tracks and watch the *Zephyr* fly by at cruising speeds of up to 109 miles per hour. Budd topped off the inaugural run by having the train glide to a halt at a stage erected at the second anniversary of the Century of Progress exhibit, where the 201 engine had debuted. The popularity of the streamlined train and diesel-electric drive were cemented in the public’s eye for decades to come. This remarkable synthesis of industrial currents launched a diesel-electric revolution in the railroad industry, though its growth from 1941 to 1945 was limited by wartime resource allocation. By 1949, however, 80% of all passenger traffic and 50% of all freight was hauled by diesel-electric locomotives.⁹

BUENG was, no doubt, well aware of this success as the *Zephyr*’s speed records were widely reported in the general and technical press. This comment comes from a BUENG civilian diesel expert after the *Zephyr* and its like had been in service for a few years: “The unprecedented success of this type of engine in the railroad field is common knowledge today, culminating as it did in the erection . . . of a brand new [GM]

⁸ Ibid., 42-43.

⁹ Reutter, “Lost Promise,” 10-35.

manufacturing plant . . . for the construction of the streamlined locomotives including the Diesel engines driving them.”¹⁰

Despite the glamorous performance of the new high-speed trains, there were numerous teething problems with the engines. GM, however, put the necessary resources into facilities, research and development, management, and people in response to the lure of the combined submarine and locomotive markets. As Kettering said, “The diesel locomotive was rapidly proving itself and to the more optimistic it looked like it was going to be a good business, so it was decided that the [201] engine would be redesigned for railroad use only.” The result of this was the famous 567 engine, thousands of which were built for locomotives beginning in 1938.¹¹ Though the 16-cylinder 567s were not used in submarines, the navy found that they were suitable to power LSTs (Landing Ships, Tank), which were amphibious transports for armor and artillery.¹² Many of the lessons learned from both engines were applied to the successors of the 201s, which powered about half of all American submarines used during the Second World War.¹³

Just as GM used the submarine application as a stepping-stone to the railroad market, Fairbanks-Morse followed suit. Fairbanks-Morse designed a two-cycle opposed piston (OP) engine (designated 38F51/4) in accordance with BUENG’s specifications for a high-speed submarine engine, although it was submitted after GM had won the bureau’s

¹⁰ Edward C. Magdeburger, “U.S. Navy Participation in Diesel Engine Development,” *Journal of the American Society of Naval Engineers* 49 (November 1937): 590-602.

¹¹ It was so named because each cylinder displaced 567 cubic inches.

¹² Eugene W. Kettering, *History and Development of the 567 Series General Motors Locomotive Engine* (LaGrange, IL: General Motors Electro-motive Division, 1951). Eugene Kettering was Charles Kettering’s son; he worked with his father in the diesel business at GM. See Churella, *From Steam to Diesel*, 39.

¹³ The successors to the 201 were designated 248, 258, and 278.

competition. The engine was so novel and promising, however, that BUENG also entered into contracts with Fairbanks-Morse to provide engines for use on submarines SS-179 and SS-180. BUENG wanted more than one engine contractor to maximize future building capacity and to mitigate risk, but the bureau also recognized that the Fairbanks-Morse engine design's relative simplicity could provide some significant advantages for the submarine operating force. The Fairbanks-Morse engines had considerably fewer parts than conventional engines like those manufactured by GM, because the unique design did not require valves or cylinder heads, and since two-cycle engines have a lower weight-to-power ratio, because every other stroke is a power stroke. The Fairbanks-Morse engines would free precious stowage space aboard the submarines, since not as many spare parts would have to be carried. Additionally, BUENG thought that the engines might require less maintenance, since there were fewer parts exposed to wear. The Fairbanks-Morse 38F51/4 submarine engine was later used as the basis for a larger engine (designated 38D81/8), designed specifically for locomotives, which were first used in 1939 in six motorcars built by the St. Louis Car Company for the Southern Railway.¹⁴

However, Fairbanks-Morse's status as a latecomer and the navy's demands for main and auxiliary engines for submarines, destroyers, and minesweepers limited its ability to compete in the railroad market. Shortly after the start of the war, the War Production Board (WPB) organized by President Roosevelt directed the allocation of manufacturing contracts based on its judgment of the nation's best interests. As a result,

¹⁴ John F. Kirkland, *The Diesel Builders: Fairbanks-Morse and Lima-Hamilton* (Glendale, CA: Interurban Press, 1985), 22-25. The first of these cars, the Alabama *Great Southern* #40, bore a striking resemblance to the *Burlington Zephyr*, a testament to the success and popularity of the *Zephyr*. See *The Diesel Builders* for details on Fairbanks-Morse's engine design and construction.

companies were generally directed to build the types of engines for which they had proven competency. The exigencies of war caused the WPB to assign Fairbanks-Morse to focus exclusively on engines for naval applications, whereas GM was able to build for both naval and railway applications, due to its market position in 1941.¹⁵

¹⁵ Churella, *From Steam to Diesel*, 75-94. Churella argues that this did not have an adverse impact on the ability of Fairbanks-Morse to compete in postwar markets. Instead he believes that the WPB more or less froze the relative position of manufacturers in the engine market for the war years, in large part because it forced railroads to accept mostly steam locomotives, since most diesel engines were diverted to military applications. As restrictions were lifted in 1944 and 1945, prospects for post-war success were then left to the companies' relative merits. For an opposing opinion more in line with this author's views, see Marx, "The Diesel-Electric Locomotive Industry," 111-28.

CHAPTER IX

THE RISE OF THE SUBMARINE OFFICERS CONFERENCE

Despite the efforts of submarine officers, the official Navy Department position on submarines had changed little by 1926. An unprecedented and extensive series of hearings was held in late 1924 before a special board to establish the "Policy with Reference to Upkeep of the Navy in its Various Branches." The Secretary of the Navy established the board on September 23, 1924; it was composed of seven senior admirals and one marine general, and it was chaired by the CNO, Admiral Edward W. Eberle. The board conducted thirty-four days of hearings, calling over sixty senior representatives of the military, industry, and academia. At the conclusion of the hearings, in January 1925, a report of over one thousand pages was submitted to the Secretary of the Navy, Curtis D. Wilbur. Included under the "Building and Maintenance Policy," essentially a wish list for future ship needs, was the goal to develop and build twelve scout submarines and twelve mine-laying submarines. Though the policy was not specific about submarine size, it was clear from the testimony that the board was thinking in terms of the larger submarines, V-1 through V-6.

In its final report the board stated that

The mission of the submarine is: first, as an arm of the fleet to assist in gaining and maintaining control of the sea. . . . The principal role of submarines being surprise attack, they must be able to operate efficiently with the fleet, and to maintain their position with it when cruising and in battle. . . .

The Board is of the opinion that . . . additional fleet submarines [of types similar to V-1, V-3, V-5, or V-6] must be provided; that minelaying submarines [of a type similar to V-4] must be provided . . . and that all submarines must be a part of the fleet in order to develop their maximum value in war.

This represented a stunning departure from the recommendations of submarine men, including some in the bureaus. It must have been a depressing development for those who had such a different vision of their future.¹

The absence of a unified submarine design agency contributed to the stale conclusions reached by the special board, but in 1926 that problem was finally addressed with the formation of the Submarine Officers Conference (SOC). The SOC was formally organized by the CNO to gather the opinions of fleet line officers so that consensus could be brought to bear in the venues where the future of submarine design was debated. The establishment of the SOC was an outgrowth of various boards and advisory committees that had been used by the CNO since 1915. The third such board, called the Submarine Standardization Board, was formed in 1918 and chaired by Thomas Hart after his return from the European theater. As noted earlier, this board was instrumental in preventing the Americans from repeating the Royal Navy's disastrous experiment with steam submarines.²

The nascent SOC wasted little time advancing the agenda of the line officers: submarine cruisers. Still smarting from the battles lost over the V class, the SOC set out to drive the design of the only three submarines remaining (V-7, V-8, and V-9) which the General Board had reluctantly endorsed (in exchange for the six big boats, V-1 through V-6). In a lengthy memo signed by Commander John Hoover, the first chairman of the SOC, he boldly recommended the purchase of building plans for U-135 (1175 tons) and U-164 (830 tons). Using these plans as a point of departure, he recommended

¹ HGB, Reel 6, "Special Hearings, Policy with Reference to Upkeep of the Navy in its Various Branches," 17 January 1925, pages 53-55 (frame numbers are not available on this reel).

² Leutze, *A Different Kind of Victory*, 67-69; Weir, *Building American Submarines*, 38-45. Also see Weir, *Building American Submarines*, 26-27 for a discussion of the first two submarine boards.

immediately building one cruiser of not greater than 1600 tons, and one 900-ton coastal boat, "following as closely as possible German practice." That the SOC recommended building the smaller boats at all is indicative of its lack of confidence in American submarines; almost all forecasts for the future submarine fleet envisioned using the existing 800-ton S-boats for short-range duty, but this came from the men who had gone to sea in them.³

It was probably just as well that Hoover was unaware of a German company's unsolicited proposal to BUC&R that would have provided everything needed to implement his plan; he would not have been pleased. For a fee of about \$500,000 the *Krupp-Germaniawerft* at Kiel had offered to sell BUC&R complete sets of building plans and supplemental technical information on the latest German submarines and shipboard machinery, along with the service of the plant's Chief Designer and other experts involved in building the U-boats, for any length of time desired.⁴ After mulling it over for five months, the General Board rejected the offer in its entirety; a counter-offer was not even proposed. The rejection was no surprise considering BUC&R's attitude about the German designs in 1921. But the Americans missed a good opportunity to benefit from the lessons learned from the Germans' ambitious and mature design and building program of the First World War. It is not clear if anyone outside BUC&R was consulted

³ RG 80/GB, memorandum from J. O. Hoover to Captain Smyth, subject: "The Submarine Situation 1927," 2 April 1927, File 420-15, 1927-1928. Incidentally, Captain Smyth was the secretary for the Special Board of 1924-1925.

⁴ The company also offered an "exhaustive treatise" on an experimental 26-knot steam-driven submarine, additional research on submarine hull design and construction, and a variety of other services.

on the matter. The decision contrasts markedly with (BUENG chief) Harry Yarnell's decision in 1931 to spend about the same sum to buy diesel engine plans from MAN.⁵

In Hoover's formal report to the CNO based on the SOC's deliberations, the committee stated that "size in a submarine, in excess of roughly 1200 tons, makes for inefficiency in utilization of personnel, cost of upkeep and, most important, in its tactical operations against the enemy." The report went on to recommend the two types discussed above for V-7 through V-9 and it further recommended that "no more vessels of anything like the size of the V-4, 5 and 6 should be constructed and that . . . work on one or both of the V-5 and V-6 should be stopped and the millions of dollars thus released be applied, if practicable, to the development of the boats referred to above." The last suggestion, while sensible from a technical perspective, was virtually impossible from a political and contractual standpoint, but it served to underscore the officers' position.⁶

Another important point contained in Hoover's report was an idea that had been debated endlessly in the various design forums, the all-purpose submarine. More often than not the prevailing opinion was that a single all-purpose boat would compromise vital military characteristics and therefore would not be advisable; different types were needed for different missions. But the obvious economical and numerical advantages and the overall uneasiness of submarine officers about the state of their submarine fleet had begun to make the idea more attractive. Hoover stated that the SOC was working on

⁵ RG 80/GB, various correspondence concerning "Proposition of Krupp-Germania Works to sell plans and information concerning German Submarines," File 420-15, 1921-1922.

⁶ RG 80/GB, letter from the SOC Senior Member to the CNO, subject: "Submarine Design and Building," 12 May 1927, File 420-15, 1927-1928.

what he called “an up-to-date general duty submarine” that could perform all fleet and patrol duties in the vast Pacific theatre.⁷

While the SOC couched its recommendations in terms that it knew would be palatable to the General Board, the War Plans Division was far more direct. In a letter to the CNO signed by the division’s director, Admiral Frank Schofield, the division went on the record for an all-purpose cruiser type. He called for large numbers of a single cruiser type not to exceed 1600 tons and he left no doubt regarding the division’s opinion on fleet service. Schofield stated that “the War Plans Division does not believe in the necessity for the development of a so-called fleet type of submarine of high speed (20 knots plus) with the corresponding disadvantages of large size, lack of reliability, and high cost. Nothing in our experience has indicated that fleet submarines, so called, can render adequate return, for the money expended, in tactical cooperation with the fleet.”⁸

For the first time since before the Great War, submariners were able to drive down the size of recommended submarines. An unprecedented number of hearings were held on those three submarines, no less than eight in all. One was even attended by the CNO and the Secretary of the Navy, which was quite unusual. There was fairly unanimous agreement on the size of V-7, about 1500 tons. But the small cruiser advocates in the SOC and War Plans, joined by BUENG around 1930, collectively overcame BUC&R’s recalcitrance and convinced the Board to go forward with a design of 1130 tons for V-8

⁷ RG 80/GB, letter from the SOC Senior Member to the CNO, subject: “Submarine Design and Building,” 12 May 1927, File GB 420-15, 1927-1928.

⁸ RG 80/GB, Memorandum from Frank H. Schofield, subject: “Military Characteristics of Submarines,” 1 December 1927, File GB 420-15, 1927-1928.

and V-9 based on U-135 (1175 tons).⁹ While agreement was being reached on the overall characteristics of V-7 through V-9, the focus of the design debates was primarily on engines. During this series of hearings the decision was made to stay with DDD or DRD machinery layouts for all three ships, but the groundwork was also laid for electric drive.

The construction of these last three boats on order just happened to coincide with a pivotal change of guard in American politics. Ever since Calvin Coolidge's inauguration in 1921, the U.S. Navy had suffered through a series of conservative Republican presidents and congresses that emphasized arms control and non-intervention in world affairs. Defense agendas were generally framed around the Monroe Doctrine, popular at a time when most were determined not to help European countries bleed each other to death, as they had in the Great War. Arms control agreements during the period culminated in the 1930 London Naval Conference, which limited battleship, cruiser, and submarine strength, although attempts to abolish the submarine were once again unsuccessful. Herbert Hoover sold the treaty to the American public as a one billion dollar savings, at a time when the country was entering the Great Depression.¹⁰ Hoover lobbied for even deeper cuts as the depression worsened, but these efforts came to a halt with the election of Franklin D. Roosevelt in 1932.¹¹

⁹ RG 80/GB, memorandum from Holbrook Gibson to the BUENG Chief of Bureau, subject: "Recommendations regarding types of submarines to be built," 1 August 1930, File GB 420-15, 1929-1930. Recall that Gibson brought U-117 across the Atlantic in 1919 as part of Freeland Daubin's command; see Chapter IV. For an account of the BUC&R position, see RG 80/GB, memorandum for General Board, subject: "Submarines V-8 and V-9 - Preliminary Design," 15 September 1930, File GB 420-15, 1929-1930. The latter memorandum's author and agency are anonymous, but it is clear that it was written by a knowledgeable individual in BUC&R. The author may have been Captain Herbert S. Howard, who was the senior BUC&R representative before the General Board nine days after this memorandum was written.

¹⁰ The Senate ratified the treaty on July 21, 1930 by fifty-eight votes to nine.

¹¹ McBride, *Technological Change*, 139-42, 157-64.

The “New Deal” Democrat quickly became the navy’s long awaited savior. Shortly after his inauguration in March 1933, he signaled that naval rearmament would become a keystone of his plans for the nation’s economic recovery. Roosevelt anticipated that millions of jobs would be created as a result, with the added bonus that most of them would be in the right places for a Democrat; i.e., in big cities and among labor unions. The effort was commonly referred to as the “unemployment bill.” A few months later, Congress passed the National Industrial Recovery Act (NIRA), which included \$3.3 billion in public works funding, of which \$944 million was earmarked for naval construction alone. Since battleships were already built up to treaty limits, the NIRA funds were allocated for 76 destroyers, 8 cruisers, 3 aircraft carriers, various auxiliaries, and 23 submarines, four of which would be funded immediately. After haggling over the designs of nine submarines over some fourteen years, submariners must have felt as if they were entering the promised land.¹²

Three weeks before the NIRA bill was signed by Roosevelt, two crucial developments led to a hastily arranged hearing before the General Board. After reviewing the early construction of V-8 and V-9, as well as engine room mock-ups, submarine officers and bureau engineers decided that the 1130-ton V-8 and V-9 were going to be too cramped for long-distance Pacific cruises (note that air conditioning was not yet available). A consensus was finally beginning to emerge among BUENG, BUC&R, War Plans, and Operations. At the same time the early tests of high-speed engines were promising, and, on paper, it looked as if the engineers could improve the

¹² Roosevelt’s support of NIRA required some adroit political maneuvering. He was lambasted by academics, pacifists, and isolationists who feared the arms race that indeed ensued. On the other end of the spectrum, the editor of the United States Naval Institute *Proceedings* characterized the coming years as the beginning of a new “*Pax Romana*” based on the American navy. See McBride, *Technological Change*, 164-71.

flank speed of the basic V-8 design from 16.5 to 18.8 knots. The increase came courtesy of the higher output power of the high-speed engines in a DERD layout. The cost was only an additional 170 tons of ship displacement for the new engines, their electrical gear, and some other minor stowage improvements; the new total ship displacement was projected to be 1300 tons.¹³ A 2.3-knot increase may sound like a small number, but in the evolution of diesel-powered submarines, it was quite a leap.

The engineers' case was smoothly presented to the General Board by their new chiefs, Samuel Robinson (BUENG) and Emory Land, who had returned to lead BUC&R. The chiefs and their staffs spoke to the admirals on the board as if they had rehearsed their lines (which they essentially had), displaying unity not seen since the defeat of steam-powered submarines. The admirals on the board were impressed; there was considerable discussion but no significant disagreements emerged. When asked by the senior member whether the additional speed could affect mission, the War Plans Division representative, Captain George Meyers, gave a typical War Plans reply: "I don't think so. I think the main thing in a submarine is the ability to keep on station and operate against the enemy. I am not one who believes the submarine will generally operate close to the fleet and with the fleet."¹⁴

There was finally a design on the table that all parties could accept. The high-speed engines solved the vibration problems of direct-connected engines. Though reservations about electric drive would weigh heavily on some engineers in BUENG for years to come, Robinson was able to persuade the doubters within his bureau to accept his

¹³ Another important factor was that an experimental electric drive installation aboard S-20 was performing successfully and resolving unknown factors associated with electric drive, such as radiated noise.

¹⁴ HGB, Reel 9, "Characteristics of New Submarines," 26 May 1933, frames 64-75.

convictions about electric drive. BUC&R was mollified by the fact that it had defeated attempts to base future submarine design on a direct copy of U-135. It had also succeeded in pushing the size of American boats back toward its preferred cruiser design, V-7 (1500 tons). Thus, BUC&R's pride was intact. As for the officers, they could live with the compromise. Although they would have preferred less displacement, it was only 125 tons greater than U-135; they were excited about the 2.5 knot increase in flank speed, and everyone was enthusiastic about NIRA.¹⁵

This meeting was a watershed for the submarine design community. After fourteen years of haggling over dozens of submarine designs ranging from 800 to 3000 tons, the General Board was finally faced with a unified group of submarine engineers and operators. Four boats were authorized in 1933 (SS-172 through SS-175) and the 1300-ton hull became the standard for future submarine design. As a result of this experience, the credibility of the SOC solidified and, from this point forward, few major submarine design changes went forward without its endorsement. Future debate over submarine design was confined within more narrow boundaries, although there were several important issues to be resolved, and a crisis over high-speed engines had yet to be weathered.

¹⁵ One of the reasons that some were adamant about building the smallest practicable boat was due to the treaty limitations in effect until 1935. With a tonnage limit in effect, a smaller boat size translated to more submarines. But, as noted earlier, it was also expected that smaller boats would be less expensive and easier to build. Even after treaties were abandoned, that would also result in more submarines on station.

CHAPTER X

PROPULSION PLANT TRADEOFFS AND EMERGENCE OF THE 1500-TON DESIGN

By the early 1930s, the SOC had been transformed from a loose confederation of line officers to an influential cadre that systematically and rigorously evaluated submarine characteristics on a regular basis. It consisted of anywhere from about ten to thirty members and, most importantly, it included representatives from a broad spectrum of agencies. Those concerns represented in the conference usually included Operations (the fleet), BUENG, BUC&R, the CNO's office (usually the War Plans Division), BUORD, and the Bureau of Navigation (BUNAV).¹ The members all had in common either operational or design experience in submarines (many had both) and they were of remarkably low rank, considering their charter. It was unusual to have more than a few members above the rank of lieutenant commander and the chairman was usually a commander. Tours of new submarines under construction and those undergoing sea trials were arranged whenever possible to familiarize SOC members with the latest developments.² Formal meetings were conducted on a regular basis, culminating in a series of sessions that could go on for months in advance of the General Board's annual hearings to determine submarine types for the upcoming fiscal year. The conference's chairman issued reports to the CNO that represented a consensus of the officers present; if the conference was divided on an issue, it was so noted in the committee's reports. The

¹ BUNAV had a unique influence on the navy as a whole as it was responsible for moving officers to each new assignment during their career.

² Bear in mind that the time that passed between when the SOC had to recommend ships' characteristics and the commissioning of a submarine was about two to two and a half years for modern submarines (those beginning with SS-172).

reports were forwarded by the CNO to the Secretary of the Navy, who in turn submitted them to the General Board prior to the formal meetings on submarine types.³

The hearings before the General Board in 1935 provided an impressive example of the growing clout of the SOC. For the first ten submarines authorized under NIRA (see SS-172 through SS-181 in appendix A), the flank speed criterion had not been specified as a rigid requirement. As mentioned in the previous chapter, Robinson estimated a flank speed of 18.8 knots if the Bureau of Engineering were permitted to specify an electric-drive machinery arrangement (with high-speed engines) and the General Board concurred.⁴ In its deliberations in 1934 and early 1935, however, the SOC decided that a firm speed criterion needed to be established as a target for the engineers. The line officers recognized that optimizing a propulsion layout for a speed that was rarely, if ever, achieved was not the most effective way to achieve their performance objectives. Instead, they reasoned that it would be more sensible to specify the speed at which the boat should travel on the surface while recharging its batteries, a far more important operational scenario. The SOC's recommendations for the six submarines (SS-182 through SS-187) for fiscal year 1936 (FY36) contained the following stipulation: "[The submarines shall have] sufficient power to maintain 17 knots in the open sea in a fully loaded condition (including maximum fuel oil) and with enough power in reserve to completely recharge the main storage batteries in eight hours. It is considered that maintained speed and not maximum speed is of importance in submarine operations. It is also believed that such a speed should be maintained while batteries are being recharged

³ Based on a review of various SOC reports in RG80/GB, File GB 420-15, 1927-1938.

⁴ The actual arrangement employed was DERD. Either two or four motors per shaft were used, since electric motors of the period were too large and too inefficient when rotating at optimum propeller speeds.

if necessary. Such a power plant appears practicable without increase of tonnage and without sacrifice to habitability.”

The key to the viability of that recommendation was that the SOC now had BUENG and BUC&R engineers within its ranks.⁵ Granted, they were sometimes junior members of those organizations, but their technical expertise gave the operators the necessary leverage that they had lacked previously. When they stated that a performance criterion was achievable, they generally knew that it was a likely objective. In this case, the criterion was remarkably close to the technological limit, and BUENG needed weeks to go through the technical calisthenics required to determine how to meet it.⁶

The bureau's studies were complicated by the emergence of yet another new engineering development. As discussed earlier, torsional vibration problems had led to the early selection of electric drive. Since then, however, BUENG had made good progress with a device known as the “Vulcan” coupling, which effectively isolated engines from the remainder of the propulsion system.⁷ This did not eliminate engine resonance, but, by divorcing the rest of the machinery from the engines, it became a straightforward proposition to predict the exact engine rpm at which critical speeds would occur, and thereby avoid them. As a result, it was becoming feasible for the bureau to

⁵ In this conference BUENG was represented by Lieutenant Commander John Huse, the former naval attaché in Berlin who had spent so much time canvassing the German engine builders a few years before, and Lieutenant Commander Lisle Small. Small was an experienced engine authority in the bureau for many years.

⁶ RG80/GB, memorandum for the Director of the [CNO's] Fleet Maintenance Division from Robert H. English [SOC Chairman], subject: “Submarine Officers' Conference to Discuss Submarine Characteristics for New Construction to be laid down during the Fiscal Year 1936,” 31 January 1935, File GB 420-15, 1936. An unintentional windfall of the 17-knot criterion was the fact that it would force the naval architects to modify the hull form to cut the water more efficiently at 17 knots rather than at 20+ knots. This was better for the SOC, since the boats would spend far more time operating at 17 knots than at any higher speed.

⁷ The Vulcan coupling introduced hydraulic fluid between metallic coupling halves to damp vibration while still transmitting torque. It was also referred to as the Vulcan clutch.

reconsider direct-drive propulsion systems along with some hybrid direct-drive and electric-drive arrangements known as composite drive (see fig. 2).

Robinson tried his best to sell his sentimental choice for the FY36 submarines, but the performance of the straight electric-drive systems fell just short of the SOC's criterion.⁸ He concluded, "it is not feasible at the present time to meet the requirements [of the SOC] by the employment of an all electric drive design," and he was forced to recommend a composite drive. However, Robinson pointed out that "if the General Board will extend the time for fully charging batteries to 9 or 10 hours in lieu of 8 hours while maintaining a speed of 17 knots with average foulness of bottom and emergency displacement, it will be practical to utilize an all electric drive installation."⁹

Robinson probably realized that he had made a tactical error in the February 15 hearing. In addition to being unable to prove electric drive could meet the design requirements, he also unveiled several interesting composite drive options. Because the composite drive system was more compact, it was possible to use six somewhat smaller engines in place of the four that had become standard for most systems. The six-engine composite layouts presented alongside the four-engine electric-drive layouts revealed that the electric-drive systems produced considerably less power. The composite arrangements were predicted to produce 6130 horsepower (hp), 7100 hp, or 7960 hp

⁸ The terms all electric drive, straight electric drive, and full electric drive were used interchangeably by engineers to distinguish between any system without a direct drive component, i.e., either DERD or DED.

⁹ HGB, Reel 10, "Proposed Military Characteristics of Submarines 182-187," 15 February 1935, frames 29-59. The engineers defined "emergency" displacement as a fully loaded submarine with its fuel tanks filled to capacity. This was a sore spot with line officers because it connoted an abnormal condition and it provided an opening for engineers to take a shortcut by using a lower displacement in their calculations, at least prior to this meeting. To the officers it was the condition in which they intended to leave port and they therefore considered it "normal" displacement.

(depending on the size of engines selected) versus 5760 hp for the best electric-drive system.¹⁰

When Robinson returned five days later, he casually crafted a compromise that altered the machinery arrangement more to his liking. He declared that four-engine alignments were “far preferable to trying to crowd 7100 horsepower [in a six-engine alignment] into these boats,” though it was conspicuous that he did not say the six-engine arrangements would not fit.¹¹ Dismissing the six-engine systems narrowed the performance comparisons appreciably. The best four-engine composite drive produced 6000 hp, only 4% more than the best electric-drive system (5760 hp). At that point it was easy to gloss over the differences between the two:

Whatever we use here in the way of propulsion I think it should be four main engines whether we use the Diesel electric or combination Diesel electric Vulcan mechanical clutch [composite drive]. I say that because, with either of the systems, we can get *about* 21 knots on the surface, with a little more in the case of the mechanical gear and just *about* [21] even in the case of the electrical gear, *about* 17 knots when charging at maximum rate, a little more in the case of the mechanical gear, and *about* [17] even with full electric drive, so that either of those seems to me to give what we require, or at least the maximum requirement that I have heard anyone express in regard to submarine characteristics. So it seems the more we study this the more it seems sure we can do that with either of the systems.¹²

It is odd that no one in the meeting explored the possibility of dramatically increasing engine power by developing one of the six-engine layouts. Robinson’s rationale was simply that “the power does not seem to be needed or justified from any point of view.” Perhaps it was because the maximum ship speed he presented for the largest system was only one knot greater than the electric-drive system, 22.4 knots as

¹⁰ HGB, Reel 10, “Proposed Military Characteristics of Submarines 182-187,” 20 February 1935, frames 70-72.

¹¹ Why he chose to quote the middle value of the three is not clear. Perhaps the largest had been determined infeasible, but that was not stated in the hearing.

¹² HGB, Reel 10, “Proposed Military Characteristics of Submarines 182-187,” 20 February 1935, frame 60, *emphasis added*.

compared to 21.4 knots, although the advantage approached two knots for some operating conditions.¹³ Though Robinson was clearly trying to sell an all electric-drive option, he steadfastly maintained that the Vulcan coupling would resolve vibration concerns with the direct drive portion of the plant, so that should not have deterred anyone.¹⁴ No one seriously challenged him, however, and this is the last record of a six-engine drive being discussed before the General Board.

Despite his efforts, Robinson was unable to convince the board to accept straight electric drive. His preparation did salvage a palatable compromise, however. He succeeded in steering the group to a four-engine composite drive that placed half of the machinery in an electric-drive alignment and the other half in a direct drive alignment.¹⁵ That would better position electric drive proponents to try to take over the entire plant in the future.

This result further illustrates the newfound respect that the SOC was enjoying. Once Robinson skillfully reduced the argument to a 4% difference in output power between the two four-engine systems, all he needed was a mere one to two hours of leeway on the charging requirement in order to justify electric drive. It is remarkable that this respected and influential bureau chief was denied it on the basis of the SOC's 17-

¹³ Those values are highly questionable, and almost impossible to verify. The figures show that the 7960 hp system could only propel the vessel at one knot greater than the 5760 hp system with a very similar hull shape. That translates to only a 5% increase in speed for a 38% increase in power. The relationship of hydrodynamic drag and propulsive power on a particular hull form can be quite complex, but 5% seems unreasonably low. Robinson did say that the hull diameter would have been increased slightly for the six-engine arrangement, which would of course hold down flank speed, but the increase must have been slight, for the six-engine plant only weighed 2% more than the four-engine system. Also note that speed values for six different operating conditions were presented for each propulsion system. For the speeds cited herein, the condition was optimal, normal displacement and a clean hull.

¹⁴ HGB, Reel 10, "Proposed Military Characteristics of Submarines 182-187," 20 February 1935, frames 60-72.

¹⁵ The six-engine systems used four engines in a tandem direct-drive alignment and two in an electric-drive alignment.

knot, 8-hour charging “requirement,” which one could argue was a bit arbitrary to begin with.¹⁶ A further example of the growing respect for the SOC was the demeanor of Rear Admiral Emory Land (BUC&R chief) during the hearings. While discussing a point on reserve buoyancy, he displayed some of the polish he had acquired in his previous assignments: “This question of reserve buoyancy is a touchy one; after all, our business is to give the operating personnel what they want; . . . you gentlemen who have to go to sea have to do the operating and we can give you what you ask for....” And later, when trying tactfully to point out the hydrodynamic penalty of carrying ships’ boats in the sail superstructure, with only a hint of condescension Land offered, “in the old days when [SOC chairman] English and I were young, the submarine went to sea without any kind of boat. They have been growing up and growing up and now the latest request is for a 26’ motor boat. That is what the forces afloat want and of course they will get it, but they are going to pay a pretty sweet price for a boat of that kind”¹⁷

One other point worth mentioning about this hearing is that the SOC made an emphatic recommendation that the aft torpedo tube nest be increased from two to four tubes and that the total number of torpedoes be increased from 16 to 24.¹⁸ This provided a 33% increase in tubes (there were four forward at this time) and a 50% increase in torpedoes and, as such, it represented the single largest increase in weaponry in the short

¹⁶ The basis of the 17-knot requirement was not explained in this meeting, but it was in the SOC’s report the following year. “The sustained submarine speed of 17 knots is required to meet the condition of a fleet cruising speed of 16.5 knots now required by the General Board characteristics for auxiliary vessels.” Seventeen was selected to provide a factor of safety. See RG 80/GB, memorandum from Robert H. English to the CNO, subject: “Submarine Officers’ Conference to discuss submarine characteristics for new construction (188 to 193),” 16 December 1935, File GB 420-15, 1936.

¹⁷ HGB, Reel 10, “Proposed Military Characteristics of Submarines 182-187,” 20 February 1935, frames 60-72. The idea of carrying auxiliary motorboats on submarines was later abandoned.

¹⁸ Four reloads were to be carried in the superstructure, a practice avoided by the Americans until then, but commonly used by the Germans in both world wars.

history of the modern American submarine. This was supposed to come at the increase of only 30 tons, giving a new total standard displacement of 1360 tons, and the recommendation was endorsed with very little discussion. The increase in launching capability and other minor changes conspired to push the boats' displacement to about 1450 tons by the time the designs were complete.

Empowered by his newfound authority, Commander English launched into particularly thorough preparations for the six submarines scheduled for authorization in 1936 (FY37). In English's report to the CNO, he opened with a classic development model by first defining the military needs of the submarine, in light of its stated mission and expected opposition:

To lay a proper foundation for the discussion of detailed design characteristics, it was first necessary to establish the purposes for which the submarines are to be used The War Plans Division of Naval Operations outlined the general plan for the probable employment of submarines in the next war from which the following fundamental principles were concluded:

Purposes:

Under the present accepted conception of submarine usage, they are to be employed for long-radius open sea operations, and are intended to operate independently or with the fleet, but not as a "Battle Task Force."¹⁹

War Plans keyed its support to English's mission concept: "The Director of War Plans considers the approval of the PURPOSES . . . covering the employment of submarines, by the Submarine Officers' Conference is *extremely* important and should be the established guide for the construction and development of [all] future submarines."²⁰

¹⁹ RG 80/GB, memorandum from Robert H. English to the CNO, subject: "Submarine Officers' Conference to discuss submarine characteristics for new construction (188 to 193)," 16 December 1935, File GB 420-15, 1936, emphasis in the original.

²⁰ RG 80/GB, memorandum from the Director, War Plans Division to the Director, Fleet Maintenance Division, subject: "Submarines – Characteristics of," 8 February 1936, File GB 420-15, 1936, emphasis added.

Evidently, English and his colleagues in War Plans had decided that it was time to drive a stake into the heart of the battle fleet submarine.

The clear statement of purposes implicitly addressed three separate missions. The old fleet concept requires no further explanation. Independent operations called for submarines operating alone and at great distances from their base against either enemy capital ships or enemy commerce. Attacks on commerce were left undefined and vague in all the relevant discussions that followed, which had been the custom since the early 1920s, due to legal and public relations concerns. The third mission envisioned was a scouting role with the fleet, and this is the role in which submariners spent most of their training, through war games and fleet exercises. They would form a line about twenty miles in advance of the American fleet, radio enemy positions, and attempt to harass the oncoming enemy fleet. The submariners routinely lobbied to increase the distance of that line from the fleet to something closer to 200 miles, to avoid being overrun by friendly vessels in the chaos of battle.

The CNO's office backed English strongly during the 1936 hearings, just as it had on paper. The board conducted an extensive cross-examination of English's views on submarine usage that filled ten pages of testimony and concluded with a request for him to detail his naval experience.²¹ This apparently satisfied the board and put to rest any lingering ideas about using submarines in close cooperation with the fleet.²²

²¹ HGB, Reel 10, "Characteristics of Submarines," 6 March 1936, frames 8-37. English's experience included three and a half years in D-boats, three years in command of an O-boat (all before 1920), Assistant Director of Submarines (to Thomas Hart), three tours in command of Submarine Divisions 8 and 15, Director of Submarines, four years of instruction at the naval academy, and over five years as navigator of a battleship.

²² It was also helpful that as V-1 through V-6 became operational, the reports back from the fleet were unimpressive. Influential submarine commander Charles Lockwood, Jr. witnessed this performance first hand as commander of V-3 in 1928. See Alden, *The Fleet Submarine*, 25.

There were few new technical requirements for submarines in the SOC's recommendations that year, though there is one point worthy of mention. The SOC had spent a considerable amount of time in its pre-hearing deliberations debating the advisability of increasing the forward torpedo nest from four to six tubes. The conference was almost evenly divided on the matter, so English declined to make a recommendation, but he did outline in great detail the design and operational tradeoffs of both schemes. The primary objection to adding two tubes among those who opposed it was that naval architects were predicting as much as a 150 ton increase in ship displacement and they considered this too big a penalty to accept.²³ This became a moot point the following year when the naval architects found a way to add the two tubes for a penalty of only 35 tons and everyone fell in line behind having six tubes forward.

It seemed fitting in the wake of the SOC's rise to power that, for the first time in its thirty-six-year history, a former submariner was named as the next chairman of the General Board. Thomas Hart, the submarine pioneer from the Great War, assumed chairmanship of the board on December 1, 1936. Since he had left the submarine design world in frustration, Hart, much like Emory Land, had been given a wide variety of assignments that greatly increased his experience.²⁴ However, the chairmanship of the board was only a consolation prize for Hart. He had been hoping to take over as Commander-in-Chief of the fleet, but that job went to Arthur J. Hepburn in June 1936.

²³ Recognize that at this point the group was specifying the requirements for SS-188 through SS-193, the seventeenth through twenty-second modern submarine authorized, whereas only the first through third modern submarine had actually entered service, due to the construction cycle lag. Everyone was leery of getting to far ahead of himself.

²⁴ Hart took command of the Third Submarine Flotilla in 1921, completed the Naval War College curriculum in 1923, attended and taught at the Army War College until 1925, commanded the battleship *Mississippi* for two years, commanded the torpedo station at Newport, R.I., was promoted to rear admiral in 1929, when he took command of all navy submarine divisions, and served as superintendent at the naval academy from 1931 to 1934.

Nevertheless, he was probably pleased to be able to have a meaningful influence on the development of submarines in their early design stages, really for the first time in his career.²⁵

Hart's preference for small, lean, and efficient submarines continued to shape his views on the submarine design problem, yet he was remarkably balanced in his tenure as board chairman. He also showed that he had done his homework. In his first submarine hearing he conducted a thorough but concise review of submarine design progress, the likes of which had never been seen in this forum. In seven pages of testimony he summarized all the salient points behind fifteen years of development, and he did it so thoroughly that a request for clarifications brought none of any consequence. A good example of Hart's approach can be found in the decision to select six tubes forward, referred to above. A thorough discussion was conducted on the merits of four versus six, but an obvious consensus did not emerge, despite the fact that the SOC now backed six. Hart personally favored four, but he decided that the decision should be made on a purely democratic basis: he asked for a show of hands. The six-tube advocates won eleven to six and though additional discussion ensued, Hart endorsed the majority opinion.²⁶ This was rather a change from the early days when battleship admirals on the board forced six unwanted boats (V-1 through V-6) on the submarine community.²⁷

An item that did not get put to a vote, however, would drive the bulk of Admiral Hart's efforts on submarines for the remainder of 1937. Hart asked Harold Bowen to

²⁵ Leutze, *A Different Kind of Victory*, 128-35.

²⁶ There were far more than seventeen people in the hearing. It was common practice for many officers not to weigh in on areas outside their areas of expertise; that accounts for the smaller number of votes.

²⁷ HGB, Reel 11, "Characteristics of Submarines," 4 March 1937, frames 94-120. Hart's summary is on frames 95-102; this should be the starting point for anyone interested in this topic.

present the latest on propulsion drives to the group. Bowen, who had succeeded Robinson as chief of BUENG, had a long history in the bureau and, unlike Robinson, did not make friends easily among the operators.²⁸ Bowen outlined the previously discussed propulsion systems and indicated his preference for straight electric drive, much as Robinson had the year before. In the lengthy presentation Hart must have overlooked the following comment by Bowen: "Recent developments in motor design have made it quite probable that given the same characteristics as the SARGO class a full electric drive may be installed this year with only a very minor increase in weight and space."²⁹ Hart was not at all sold on use of straight electric drive and apparently he had assumed that the boats under consideration that day (SS-194 through SS-197) were going to have a composite drive like the ones authorized the year before.

In fact, BUENG had the latitude to specify the propulsion plant of its choice as long as it met the 17-knot charging criterion of the SOC. Like Robinson, Bowen was an avid supporter of electric drive. Additionally, Robinson had written Bowen a letter after leaving BUENG to urge him to abandon composite drive.³⁰ Hart did not find out about the BUENG decision to revert to straight electric drive until after the contracts were placed and, as a result, he launched a campaign to remove it.

To understand Hart's perspective, the reader should take a moment to consider the pros and cons of the two propulsion systems. The engineering tradeoffs of the two drives are shown in table 1. The chief advantage of electric drive was de-coupling the engines

²⁸ Bowen was a graduate of the specialized curriculum at Columbia University discussed in Chapter III. After about fifteen years in various assignments at sea and ashore, Bowen joined BUENG in 1931. He spent the bulk of the next eight years as assistant chief or chief of the bureau.

²⁹ HGB, Reel 11, Characteristics of Submarines," 4 March 1937, frame 108.

³⁰ Bowen, *Ships, Machinery, and Mossbacks*, 130.

Table 1. Engineering Tradeoffs of Electric Drive Versus Composite Drive

Electric Drive	Composite Drive
Engines are not mechanically connected to the shafting and may be operated at a constant speed ²	More horsepower per pound of machinery ⁶
More freedom to locate engines ³	Less horsepower losses in transmission ⁷
More flexible controls for maneuvering purposes and full power available from engines when backing the vessel ⁴	One half of the plant is independent of any electrical equipment ⁸
Smaller propelling motors can be used ⁵	Improved survivability ⁹
	Better access to machinery for a given power in a given space
	Lower cost ¹⁰

Source: Compiled from comments by Harold Bowen in HGB, Reel 10, "Characteristics of Submarines," 6 March 1936, frames 22-26. The comments provided in the notes are either Bowen's comments taken from his testimony (indicated with quotation marks) or the author's observations.

1. See figure 2 for schematic diagrams of the two drive systems.
2. This simplified torsional vibration problems, and reduced engine maintenance. Also, "in the composite drive it is necessary to do a considerable amount of design work in connection with locating motors on a common gear."
3. "In the composite drive it is quite a design problem to select shaft lines most advantageous for the location of the direct drive engines."
4. "Direct-connected engines are non-reversing for reasons of simplicity." Consequently the electric drive half of the plant was used to back the ship with a composite drive, whereas all engines could be used for backing with straight electric drive.
5. "In straight electric drive it is very convenient to use four individual motors on a shaft. This is impracticable in the composite drive." At this time, motor technology had not advanced to the point that a single motor could be used on each shaft, so either two or four were used. This is a transient benefit that disappeared as motor technology improved.
6. The weight of the respective propulsion plants on *Salmon* class submarines (SS-182 through SS-187) was estimated at 322,000 pounds versus 358,000 pounds, in favor of composite drive, about 10% less.
7. For *Salmon* class submarines, composite drive maximum shaft horsepower was 5652 versus 5380 for straight electric drive. This represented a 5% increase in favor of composite drive. This translated to about 0.4 knots of ship speed between 17 and 20 knots. Note that this difference could have been magnified considerably by exploiting the space advantages of composite drive and using six engines instead of four, as discussed earlier in this chapter.

Table 1 – Continued

8. **“The electrical power controls could be totally inoperative and yet the direct drive engines could be put on the screws and be run indefinitely and make about 14 knots.”**
9. **“In an electric drive submarine, if either the motor room or the generator compartment is flooded [or rendered inoperable by underwater explosion shock] all propulsion is wiped out.” The composite drive vessel still had the capability stated in Note 8.**
10. **Composite drive required less equipment, smaller motors, and cost less. A diesel-direct drive system would have been simpler and less expensive than either system described here.**

and propulsion shafting. This allowed the engines to run at constant speed, it greatly simplified vibration problems, and it reduced engine maintenance. The other main advantages were arrangement flexibility and more simplified controls. On the other hand, composite drive had many compelling advantages: greater output power, less space required, improved survivability, and lower cost. Hart's opinion was that those considerations should be paramount.

With BUENG solidly behind straight electric drive and BUC&R deferring to its sister agency, Hart knew that he would need the support of the fleet. Over the summer of 1937, Hart initiated a correspondence with Rear Admiral Joseph DeFrees, then head of the submarine fleet operating out of San Diego. Hart's objective was to get the fleet to support composite drive, reduced complexity in submarine design, and Hart's other pet project, a small submarine of about 800 tons. Hart did not want the small submarine to replace the 1500-ton design, but he thought it should be available in significant numbers to augment the fleet boat in time of war.³¹ Though the correspondence was friendly and the men agreed on many points, DeFrees's reaction would still have to be described as lukewarm. In his first letter to DeFrees, Hart lamented the "complexity and elaborateness" that had been added to submarines along with the "amount of automatic apparatus that goes into ships" and he requested DeFrees's observations.³² In his reply, while acknowledging the value of simplicity, DeFrees told Hart, "I do not believe that submarine equipment is any more complex than equipment of other types of naval ships."

³¹ Recall that this is the same idea that the first official SOC had recommended in 1927.

³² RG 80/GB, personal letter from Thomas Hart to Joseph DeFrees, dated 29 June 1937, File GB 420-15, 1937.

However, Defrees did support composite drive: “My opinion is that either the [composite drive] . . . or the all hydraulic coupled drive [DDD], is indicated [meaning desired].”

Defrees also explained why operators had heretofore resisted an obvious alternative. Most submarines in other navies of the world were being designed with two large engines, one per shaft, in a direct-drive alignment. This was, in fact, the prevailing design scheme in virtually all German, Japanese, and British submarines built before and during the Second World War.³³ The advantage was simple. Two large engines could be made to develop more power for a given space than four smaller ones. So, why did almost all American schemes use four? DeFrees provided the answer in his second letter to Hart. He pointed out that with two large engines (one of the schemes proposed by Hart) “ ‘service speed’ depends on reliable operation of two main engines,” so that if one goes out the submarine will proceed on only half the available power versus three fourths the available power if one goes out in a four-engine arrangement. DeFrees also noted the fact that the parts (cylinders, pistons, cylinder heads, etc.) of the larger engines are bigger, heavier, and more difficult to maintain. DeFrees simply believed that reliability was more important than higher speed. This was ingrained in the submarine force for

³³ Carl Boyd and Akihiko Yoshida, *The Japanese Submarine Force and World War II* (Annapolis: Naval Institute Press, 1995), 40-42; F. W. Lipscomb, *The British Submarine* (Greenwich, UK: Conway Maritime Press, 1975); Eberhard Rössler, *The U-Boat: The Evolution and Technical History of German Submarines*, trans. Harold Erenberg (Annapolis: Naval Institute Press, 1981). Submarines of foreign navies are sometimes referred to as “electric drive” although their propulsion systems were essentially the same ones that American engineers referred to as direct drive. This apparent contradiction stems from the fact that almost all submarines had electric drive in the sense that they were propelled by electric motors underwater. American engineers used the term “electric drive” to denote a system that used the electric motors for propulsion at all times, both on and under the surface, and that is how the term is used in this study. As a result, the sources cited do not overtly refer to the foreign submarines as direct drive, but that fact can be deduced by comparing the horsepower ratings of the motors with the horsepower ratings of the diesel engines. Because they were used at all times, the motors in American electric drive submarines had almost as much power as the diesel engines, usually 85% to 90% as much. Since motors in direct drive systems only had to propel the vessel underwater, and because underwater power was limited by contemporary battery capacity, they could be much smaller. The submarines of foreign navies typically had motors with horsepower ratings between 15% and 30% of the diesel engine horsepower ratings.

three reasons: the bad experiences with engines in the 1920s, early problems with high-speed engines that were just beginning to emerge in the fleet, and the enormous operating area of the Pacific Ocean. The submariners expected to be operating a long way from bases and a few knots of ship speed was not enough to offset their reliability concerns. In the end, the only support that Hart could extract from DeFrees was for composite drive. DeFrees did not mind a direct drive component of the plant as long as there were four engines. As far as smaller, less complex submarines, DeFrees would not offer Hart very much: "I am naturally in sympathy with your desire to simplify where possible, but . . . the essential characteristics needed in submarines should not be sacrificed . . . it would appear that a certain minimum displacement and degree of complexity must be accepted."³⁴

Though Hart did not invoke it, there was a powerful historical precedent for composite or direct drive. Prior to the next hearing he circulated a memorandum to members of the General Board on the drawbacks of electric drive. In it, he constructed an argument that sounded remarkably like the evolution that battleship technology underwent in the 1920s. Recall that Samuel Robinson's electric-drive installation tested on *Jupiter* led to the adoption of electric drive in battleships for many years until reduction gear technology could be improved. Once that occurred, the navy never used electric drive in battleships again. Hart made the same point. Reduction gearing had made composite (or direct) drive more efficient and less expensive. Furthermore, electric drive had a clear survivability disadvantage, which should have weighed just as heavily among line officers as the reliability issue just covered.

³⁴ RG 80/GB, personal letters between Thomas Hart and Joseph DeFrees, 29 June, 16 July, 24 July, 5 August, 19 August, and 1 September, all 1937, File GB 420-15, 1937.

But the die was cast as far as submarine officers were concerned. While Hart was drafting his first letter to Defrees, the SOC had been considering some simpler and smaller submarine designs proposed by Hart. In its reply to the General Board, the SOC bristled at Hart's suggestions. In addition to rejecting any attempt to reduce submarine size and complexity, the SOC added somewhat defensively that it was "not prepared to scrap several years of progressive work and study" by the members of the conference. Hart may have made a mistake by trying to push smaller and simpler submarines at the same time that he was trying to reinstate composite drive. The SOC appears to have taken Hart's generic attack on complexity in part as an attack on electric drive, although that represented only a fraction of Hart's concerns about complexity.³⁵ The SOC also sensed an attempt to infringe on its hard-won jurisdiction, and it responded with a unanimity that had become standard when challenged from the outside.

Submarine officers rallied to the defense of electric drive in the next formal hearing. The tradeoffs of the various propulsion plants, by now familiar to all, were rehashed along with several other technical issues. Commander Charles Lockwood, Jr., sent to the hearing by DeFrees, came out in favor of straight electric drive, despite what DeFrees had expressed to Hart in their letters.³⁶ He also convinced other officers who were undecided to throw their support behind it. As he did before, Hart put matters to a vote. Electric

³⁵ Hart's concerns about complexity were not really the same as Land's complaints about U-boat complexity after the First World War. Hart was referring to features like automatic operation of equipment, extensive reliance on electricity, air conditioning (truly essential in the Pacific theater), hotel services, and complexity of the propulsion plant. Hart believed that American sailors could do with less, as the Germans had, and did again in the war to come.

³⁶ Lockwood took over as chairman of the SOC about the time of this hearing.

drive was preferred ten to one, with several abstentions, and Hart chose not to take it any further.³⁷

One cannot help but wonder if Hart reflected on the irony of these events. In 1920 he had led a determined effort on behalf of submarine officers to convince the General Board to abandon fleet submarines. Hart was also as important as anyone to the early nurturing of the committees that evolved into the SOC. In 1920, the General Board had brushed the submarine officers' recommendations aside. And now, Hart was the chairman of that board, but he was obliged to defer to the group that he once led. To his credit, he conducted himself in as fair and impartial a manner as any chairman had.

Hart was just not in step with the times. He expected sailors to be willing to live and work in Spartan conditions. He thought that ship designs should be as lean as possible and he truly believed that sailors would be more effective as a result. But the officers who were rebuilding the navy believed that they knew from experience what the sailors could and could not do. What Hart called luxury, they considered adequate. His ideas about direct drive and smaller submarines, however, were never discredited from a technical point of view; they were just not put into practice. The German submarines used during the war to come proved that lean, direct-drive submarines could be formidable weapons.³⁸

³⁷ HGB, Reel 11, "Characteristics of Submarines," 15 October 1937, frames 320-55.

³⁸ See appendix B for a brief comparison of German and American submarines.

CHAPTER XI

A DESIGN SOLIDIFIES

Perhaps one of the reasons most submariners never strayed from electric drive was the dismal performance of the early high-speed engines, which only underscored the reliability issue. As discussed earlier, the navy had the luxury of three engine manufacturers to choose from, GM, Fairbanks-Morse, and HOR. Of the first ten modern submarines, seven had GM engines, two had Fairbanks-Morse engines, and one had an HOR engine (see appendix A for specifics). By the end of 1936, the first four had been commissioned and almost immediately the GM engines began having problems. By the end of 1938, the seven boats with GM engines had experienced 148 engine casualties, about one in five being piston seizures. The problems were so fundamental that every one of the engines in these seven boats had to be replaced, a repair which required a major lay-up in a shipyard, typically lasting six to nine months. The two boats with Fairbanks-Morse engines and the one with an HOR engine had a similar fate.¹ As a matter of fact, the first modern submarine that *did not* have its engines replaced was SS-185 (*Snapper*). *Snapper* was the fourteenth modern submarine built and it did not enter service until December 15, 1937, approximately four years after the keel was laid on the first of the NIRA boats authorized during Roosevelt's first administration. The view from the fleet in the summer of 1937, according to Joseph DeFrees, was that the engines should be ranked in "the following order of merit for service requirements: (1) Hooven-

¹ Alden, "Development of the High-Speed Diesel Engine," 47-48.

Owens-Rentschler, (2) Fairbanks-Morse, and (3) Winton [GM].”² Considering the record, it would seem that GM was in dire straits.

In reality though, GM’s first mover status and its aggressive style left it ideally positioned to profit from its problems. The reason that seven of the first ten submarines had GM engines to begin with was that its Winton Division had been the first manufacturer to meet the navy’s design criteria in the 1932 engine competition. Moreover, GM’s practice of forcing itself, if necessary, on customers to solve their problems paid big dividends. As it had done with the railroad industry (see Chapter VIII), GM sent its experts out to the boats under construction to oversee installation and grooming of its engines. As early as January of 1936, GM had three engineers assigned for over six months to *Porpoise*, *Pike*, *Shark*, and *Tarpon* (the first four modern submarines) to oversee operation of their engines.³ GM also requested blanket approval for its engineers to ride the boats after commissioning, although BUENG was only willing to grant approval on a case basis.⁴ GM’s proactive behavior actually made it difficult for BUENG to stay apprised of problems and resolutions. Harold Bowen (BUENG chief) commented, “I had troubles of my own in getting information about the General Motors engines. As soon as a submarine skipper having these engines got into port, he would call up George Codrington [president of GM’s Winton Engine Division] and tell him what he needed to keep operating. Spare parts would be shipped promptly or a service engineer [would] be flown to the site at no charge. With a service like that, the

² RG 80/GB, personal letter from Joseph DeFrees to Thomas Hart, 16 July 1937, File GB 420-15, 1937.

³ RG 19, GM-Winton letter to BUENG, no subject, January 16, 1936, File SS/S41- Submarines, 1936.

⁴ RG 19, GM letter to BUENG, no subject, June 24, 1936, File SS/S41- Submarines, 1936.

skipper felt he would be wasting his time and mine to report his engine problem to me.”⁵ Bowen also exploited GM’s penetration of the locomotive market. As Bowen explained, “[Since GM] engines similar to our submarine engines were running successfully in locomotives out of Chicago, my young men haunted the round houses and rode diesel locomotives all over the country to get the latest ‘dope’ on [engine performance].”⁶ Although Eugene Kettering later acknowledged that the 201 engines’ performance was troublesome, GM must have also wanted to make sure that it did all that it could to restore reliable operation for an important customer. By 1938, after four years of naval rearmament and on the verge of even more, it was becoming evident that the navy was going to be a bigger market than anyone could have imagined in 1932. GM was also marketing the 567 engine for LST use and GM would not have wanted the company to get a bad reputation in the submarine community. All of this is not to suggest that Fairbanks-Morse and HOR were unresponsive, but the severity and timing of the problems favored GM.

Naturally, the fleet did not stand by idly. The myriad engine problems were brought to the attention of the Assistant Secretary of the Navy (Charles Edison) by many, including Joseph DeFrees, who had corresponded so optimistically about engines with Hart just one year earlier. Harold Bowen commented in his autobiography that DeFrees “complained that his submarines with ‘Bowen’ engines were broken down from Alaska to Panama.” With characteristic defiance Bowen added: “so I contracted for more

⁵ Bowen, *Ships, Machinery, and Mossbacks*, 132.

⁶ *Ibid.*

submarines just like them.”⁷ Bowen and BUENG had confidence that Fairbanks-Morse would recover, but the navy proceeded cautiously nonetheless. Only eight of the fifty-four submarines (15%) authorized from FY34 to FY41 were purchased with Fairbanks-Morse engines. Considering the poor start, it is remarkable that Fairbanks-Morse engines would eventually be used in about half of the modern American submarines serving in the Second World War.

HOR was not so fortunate. HOR engines installed in *Pompano* (SS-181), the last of the first ten modern boats, damaged themselves beyond repair under operation before *Pompano* could leave its building yard (Mare Island Naval Shipyard) in mid-1937. The engines were returned to the manufacturer just as the Fairbanks-Morse engines had been the year before. Problems in other boats over the course of the following year led DeFrees to complain formally to Edison about the HOR engines in a letter sent to him in December 1938.⁸ In eighteen months DeFrees had completely reversed his opinion of HOR engines.

Harold Bowen, however, believed that his bureau had the situation under control. Bowen was reluctant to give up on HOR, for, in the early days of the program, HOR was seen as the most promising of the three engine builders. HOR was the only remaining MAN licensee among navy suppliers and its engines incorporated many engineering features developed by the respected German engine builder.⁹ In fact, the engines ordered for *Pompano* were essentially copies of the auxiliary diesel engines selected for the

⁷ Alden, *The Fleet Submarine*, 50; Bowen, *Ships, Machinery, and Mossbacks*, 131.

⁸ Gary E. Weir, *Forged in War: The Naval-Industrial Complex and American Submarine Construction, 1940-1961* (Washington D.C.: Brassey's, 1998), 45-49.

⁹ The Fairbanks-Morse OP engines were also inspired by a German design, a Jumo OP engine built by *Junkers* for commercial flying boats. See Alden, *The Fleet Submarine*, 47. The GM engine was the only one of the three based on standard American design practice, a vee or in-line cylinder arrangement.

modern German light cruiser *Leipzig*. Also, the HOR engines were the most powerful of those produced for the first ten boats. Bowen declared a one-year moratorium on buying from HOR and applied more pressure on the engine builder, reminding the company that a quick resolution of the problems would decide HOR's future with the navy.¹⁰ By mid-1939 a recovery plan was in place and positive results were beginning to filter back from the fleet by late that year. BUENG resumed the purchase of HOR engines in 1940.¹¹ Although the situation appeared to be under control, the fleet was actually furious with Bowen. In order to appreciate why, it is necessary to digress from submarines for a moment.

The submarine engine controversy was a mere sub-plot compared to another running battle between BUENG and the fleet. One of Bowen's top initiatives and, indeed, a lasting contribution to marine engineering, was his introduction of high-temperature, high-pressure steam in the steam turbines of all major surface combatants. When Bowen took over as BUENG chief in 1935, steam conditions in power plants typically did not exceed a pressure of 400 pounds per square inch (psi) and a temperature of 700 degrees Fahrenheit. Bowen championed a dramatic increase of both, which could either increase power, reduce the size and weight of machinery, increase range, or accomplish a combination of all three. The drawbacks were the potential of complicating plant operation, reducing safety, and reducing reliability. The operating fleet, the Bureau of Inspection and Survey, and the General Board firmly opposed Bowen and a classic line officer-engineer conflict ensued. Without going into the details of the controversy,

¹⁰ One example of the meetings with HOR can be found in RG 19, "Report of Conference at Hooven, Owens, Rentschler Company, Hamilton, Ohio on November 28, 1938, Casualties on Test of HOR Engines," File SS/S41- Submarines, 1938.

¹¹ Weir, *Forged in War*, 45-49.

suffice it to say that Bowen got his way. By 1937, battleships, aircraft carriers, cruisers and destroyers were all being fitted with propulsion systems capable of operating at temperatures up to 850 degrees Fahrenheit and pressures as high as 600 psi. That the systems Bowen advocated were adopted and successfully operated in the coming war is sufficient to attest to his foresight. However, his autocratic style left many in the fleet smoldering with resentment.

Bowen did not take kindly to “suggestions” from the fleet. During one meeting over a relatively minor controversy in 1937, Bowen turned to the Secretary of the Navy (Swanson) in exasperation and said, “Mr. Secretary, there are about twelve Naval officers trying to be the Engineer-in-Chief of the Navy.¹² My advice to you is to pick one that you have confidence in for Chief and fire the other eleven.” Admiral William Leahy (then CNO) backed him up that day. In December 1937, as DeFrees and Bowen were sparring over HOR in the background, DeFrees went on record stating that Bowen was “gambling with National defense by installing experimental and unproven [and unneeded] engine designs.” This, of course, was in reference to high-temperature, high-pressure steam in surface ships. In response to the General Board’s support of that charge, Bowen stated that “the General Board not only exceeded its authority under the specious plea that design in engineering is a ‘military characteristic,’ but it invaded a highly technical field in which it was not competent to function” And as for his nemeses on the Board of Inspection and Survey, Bowen recorded that the board “fell into the same fallacious reasoning [as that used by the General Board] and never ceased

¹² The BUENG chief could reasonably claim that title, with the understanding that the BUC&R chief was the navy’s “Chief Naval Constructor.”

attempting to arrogate to itself design functions which were my sole responsibility.”¹³ It is most ironic that the fleet so stubbornly opposed Bowen’s engineering improvements, for they were vital to the development of the 34-knot fast fleets that were needed to defeat Japan in the coming war.¹⁴

So despite HOR’s successful recovery, the fleet’s opposition to Bowen left the company in a precarious position. It also did not help that the affection for German engines had about run its course in the U.S. Navy, at least among operators. The culmination of Harry Yarnell’s work on submarine engines in BUENG had resulted in the purchase of building plans from MAN in 1931. Main engines built to those plans, which utilized metric units, were a complete failure in *Cachalot* and *Cuttlefish* (V-8 and V-9). No adequate explanation has ever been given for the failure of those metric-MAN engines, as they were called, though it has been speculated that the builders could not cope with metric dimensions.¹⁵ A further public embarrassment for HOR occurred when an enterprising *New York Times* reporter wrote a series of articles airing the navy’s problems, primarily exposing the steam plant controversy discussed above. In March 1939 the reporter published *Pompano*’s tale of woe, in which the reporter incorrectly speculated that the Germans were deliberately undermining the navy’s efforts by licensing engines of inferior design to HOR.¹⁶ But the coup de grâce for HOR came when gear failures began to occur on some submarine engines early in 1941. By then the

¹³ Bowen, *Ships, Machinery and Mossbacks*, 64-126. Weir, *Forged in War*, 45-49.

¹⁴ James L. McVoy, Virgil W. Rinehart, and Prescott Palmer, “The Roosevelt Resurgence (1933-1941),” in *Naval Engineering and American Seapower*, ed. R. W. King (Baltimore: Nautical and Aviation Publishing Company, 1989), 162-64.

¹⁵ Alden, *The Fleet Submarine*, 42.

¹⁶ *New York Times*, “Defects are Found in a German Diesel,” March 19, 1939.

climate had completely changed. Bowen was forced out of the bureau system by his political enemies in late 1939 when BUC&R and BUENG were merged into the Bureau of Ships (BUSHIPS), which he bitterly opposed.¹⁷ The resentment toward HOR remained and Ernest King, then CNO and commander in chief of the fleet, ordered that HOR diesels would no longer be used in American submarine construction.¹⁸ All future engine orders were divided between GM and Fairbanks-Morse.

Thus HOR became a victim of Navy Department politics. The HOR engines that remained in the fleet performed well for the most part, and there is no evidence that they fared any worse than those produced by GM or Fairbanks-Morse.¹⁹ Weir argues that Bowen opposed the elimination of HOR engines solely to protect his engineering empire, but there is no compelling evidence to support that. Bowen defended his bureau regardless of the situation, and he could be most unpleasant to deal with at times, but he had a keen engineering mind. He supported the engines because their design was sound; the record proves that. As it turned out, they were not essential to the war effort, but the ultimate success of GM and Fairbanks-Morse was not foreknown in 1941.

With the ouster of Bowen and the defeat of Hart's ideas for simpler drives and smaller boats, the American submarine design came together. Displacement remained at about 1500 tons throughout the war and all new boats used straight electric drive. Many

¹⁷ Samuel Robinson returned to become the first chief of BUSHIPS, and Bowen was put in charge of the Naval Research Laboratory, a compromise to Bowen's supporters and detractors which gave him an important post, but guaranteed that he could no longer directly influence ship design. See Bowen, *Ships, Machinery, and Mossbacks*, 116-37.

¹⁸ Weir, *Forged in War*, 45-49.

¹⁹ Alden, "Development of the High-Speed Diesel Engine," 48.

incremental improvements were made over the coming years, but the basics were set well before the U.S. entered the war.²⁰

So, why did the Americans settle on straight electric drive? An excellent case can be made for direct or composite drives. They were more compact, more powerful, more survivable, and cheaper. And, as noted earlier, direct drive systems were the propulsion system of choice in all the other major navies of the world. Assuming no undue influence from electrical equipment manufacturers, and none is evident, the selection must have been made for two reasons. The systems were easier to operate and they maximized reliability of the engines.²¹

Why was ease of operation so important? An all electric-drive boat was still a fairly complex vessel. One reason was that officers were concerned about having a sufficient talent pool of mechanics who could maintain complex, finicky diesel engines. This was not overtly stated very often, but a subtle theme along these lines can be seen in the sources. That is what Samuel Robinson was alluding to when he pointed out that his electric drive on *Jupiter* was “easily operated by relatively unskilled sailors” and what Ormond Cox meant when he spoke of engines that “the ordinary average man” could handle (see Chapter VII).

Just as the officers’ consideration for their crews in part drove the choice of electric drive, this awareness also contributed to the configuration of the 1500-ton design that was taking shape. The navy’s ability to attract talented personnel to submarines is why

²⁰ See Friedman, *U.S. Submarines*, for the most thorough treatment of these details.

²¹ A thorough review of the main propulsion systems as well as the entire fleet submarine can be found in the original navy technical manuals for the boats. See United States Navy Department, Bureau of Naval Personnel, *The Fleet Type Submarine, NavPers 16160* (June 1946). Available [Online]: <<http://www.maritime.org/fleetsub>> [April 14, 2002].

shipboard standard of living was so crucial to submarine officers, and why they firmly resisted any attempts to cut back hotel services. This was usually a touchy subject in the sources because of the implication that those favoring greater accommodations were “soft.” But submarine officers were quite aware that their crews came from an all-volunteer force, especially during peacetime. The navy needed incentives to attract top personnel. During one hearing in 1922, some senior officers spoke openly that an American submarine would have to be about 25% larger than a German submarine of comparable service, simply due to differences in accepted standards of living. At the conclusion of that hearing an unusually frank exchange occurred among Admiral John Rodgers, then General Board chairman, Rear Admiral Joseph Strauss, a board member, and Rear Admiral John Robison, BUENG chief:

Admiral Strauss: But to go back again, the Germans did good work with their submarines.

Admiral Robison: Well, we have got to take into consideration circumstances that are peculiarly American. The petty officers in the German submarines had an average of over 10 years' service, and they were chosen particularly for that work. It was a corps d'elite. They were specially rewarded.

Admiral Rodgers: And they were Germans.

Admiral Robison: Yes, they were also Germans. We have a different condition to cope with. Our people contrast their living conditions on submarines with those that obtain on our other ships. . . . You can't get especially high skilled men to voluntarily choose the submarine service. We have got to find some way to get them. Their conditions of living and working have to be improved if you expect to get the degree of satisfaction in the operation of our submarines that will compare favorably with the Germans.²²

The conversation sums up two undercurrents in submarine officers' thinking throughout the period. The navy could not count on an endless supply of highly skilled diesel engine mechanics, and American crews would not tolerate the conditions the Germans operated under during the First World War. Officers therefore favored straight

²² HGB, Reel 5, “Characteristics of Scout Submarines. Characteristics of Mine-Laying Submarines,” October 23, 1922, frames 72-121.

electric drive in part for the same reasons they insisted on first-rate accommodations: to create a favorable living and working environment for their crews.

It may not be obvious that electric drive was necessarily easier to operate and more reliable. The benefits for the engines is clear, but overall reliability was still uncertain, considering the performance of all of the additional electrical gear required. At first glance the system appears more complex and, indeed, it concerned some (mostly senior) officers who were uncomfortable with large quantities of electricity being transmitted all over the machinery spaces. Hart was certainly skeptical. But all that the system required was the addition of dedicated generators and larger motors (a definite cost and weight drawback) and a new unit called the control cubicle, which routed all of the electrical power for propulsion. Furthermore, despite a lot of hand wringing about the reliability of motors and other electrical gear, it turned out that motors and generators made to the navy's specifications were very dependable. Thus, to some extent at least, engineers tailored their designs to the crews that would operate them and to circumstances that were "peculiarly American."

CHAPTER XII

CONCLUSION

Despite the impressive growth of submarine and naval air technology between the world wars, the battleship remained the centerpiece of American naval doctrine in 1941. A confidential report prepared by the president of the Naval War College in September 1941 was circulated at high levels to dispel any notion that the navy could ever rely on the aircraft carrier as a capital ship. In it Rear Admiral Edward Kalbfus opined that the carrier could not displace the battleship for *any* major mission, even commerce warfare. Kalbfus was silent about the submarine's role in trade warfare. In fact, his only mention of submarines was their role in holding the Singapore-Philippines-New Guinea triangle in the early phases of the war, along with "shore based air power, 'mosquito fleets,' and mines." Kalbfus closed his analysis of battleship primacy with an assessment of the previous two years of war in Europe which could have been written in France in July of 1914: "The methods employed, and the skill displayed in handling any weapon are the final determinants of its effectiveness. Weapons in apathetic and timid hands do not produce the results which accrue to those who wield the same weapons with intelligent determination and proficiency." He concluded the paper by asserting that "the big gun, enhanced by air power, remains the supreme weapon of the seas."¹

This ill-timed and outdated assessment is presented to underscore the conclusion that of all non-technical factors considered, battleship doctrine was the most dominant influence on interwar submarine development. Even though air advocates did manage to

¹ RG 80/GB, Edward C. Kalbfus, "A Study of the Relative Merits of a Balanced Navy and a Carrier Navy and the Conclusions Reached," September 1941, File GB 420-15, 1941.

carve out a sizeable niche in the interwar navy, the vast majority of resources were dedicated to fulfill the strategic vision of the Gun Club. Submariners were still a long way from competing with either. This can easily be seen in a hypothetical example. *Iowa*-class battleships ordered in 1940 cost \$90 million each. In the same year, each 1500-ton fleet submarine cost about \$6 million. Therefore, for each battleship the navy could have done without, it could have built fifteen additional submarines. For the cost of one less battleship in 1940, the modern submarine operating force then authorized could have been increased from 38 to 53 boats, an increase of 39%.² It is doubtful that an *Iowa*-class battleship, the first of which was delivered in the spring of 1943, would have had the same impact on the war effort that an extra fifteen FY40 submarines would have had, all of which could have been commissioned before the Pearl Harbor attack.³

Just as fleet doctrine drove the navy's flirtation with steam-powered submarines in 1918, it also dictated that the little funding available be used on the design of V-1 through V-6 in the 1920s. The navy wasted the better part of ten years on the development and construction of those six submarines to determine what most submarine proponents instinctively knew, that they were almost a complete waste of time and money. Had the General Board been receptive to what Captain Hart and almost all other submarine supporters had to say in 1920, the fleet boat of the Second World War would have

² Costs are taken from RG 80/GB, Lieutenant J. E. Hamilton, "Construction Costs Corrected as of 30 October 1939," File GB 420-15, 1939. Incidentally, *Essex* Class aircraft carriers ordered in 1940 cost \$47 million per ship, according to the same source. The submarine force size numbers can be determined from the information in appendix A.

³ The last FY40 submarine was delivered in January 1941. It is conservatively assumed that with suitable expansion to the facilities at the building yards in 1939, when the submarines would have been ordered (which was accomplished rapidly in subsequent years), the additional boats could have been completed no more than ten months after the last FY40 boat actually produced.

developed much more rapidly, and there would have been another dozen or so boats available to participate in the lean early war years.

The inferior role of submarines also had a negative impact on development of submarine tactics. It is tempting to suggest that, if only the submarines had been given a more independent role in exercises and war games, then perhaps they would have been better prepared for the coming war. But that is not at all likely. One of the crucial reasons that flaws in the battleship doctrine were not revealed in interwar exercises is that the games lacked any measure of basic scientific rigor. Most of the referees were Gun Club members and they made sure that the results were consistent with their pre-conceived ideas, just as Kalbfus ultimately fell back on *élan* in his analysis of the “balanced fleet.”⁴

There was, however, an important windfall that came from being on the periphery of the fleet. This allowed submarine engineers and operators to develop their vessels in relative obscurity. Many meetings and much of the correspondence were classified, and relatively few people were involved. Before the Second World War, there was no comprehensive submarine design treatise of any consequence available in the open literature.⁵ As a result, pressure from Congress, the public, and even within most quarters of the navy was minimized. Once the SOC and most engineers had reached a consensus on their designs, there was really no one with the knowledge or technical wherewithal to

⁴ McBride, *Technological Change*, 195.

⁵ William Hovgaard, *Structural Design of Warships* (Annapolis: Naval Institute Press, 1940) is perhaps the earliest example, although fewer than 40 pages in this 400-page book are devoted to submarines. Hovgaard was then in charge of the three-year naval architecture program at MIT. A former Danish naval constructor, he served as a mentor for the vast majority of American constructors in the interwar period. The first edition of Hovgaard's book cited was published in 1914, but there was very little space dedicated to submarines in that edition. There were a few articles available in technical journals, but no comprehensive treatments existed before this one. Also see Saunders, *Hydrodynamics in Ship Design*.

challenge them. Perhaps too, just as they enjoyed the screen provided by their obscurity, submariners benefited from the big gun advocates being distracted by the rearmament funding that was lavished on the navy after 1932.

Just as the submarine quietly improved during the interwar years, the composition of the navy's senior leadership slowly began to change. Whereas battleship proponents dominated senior positions in 1917, submarine advocates or sympathizers had widely penetrated the Navy Department by 1941. Thomas Hart was given command of the Asiatic Fleet in 1939, Samuel Robinson became the first chief of BUSHIPS in 1940, Emory Land directed the phenomenal construction of a merchant marine fleet second to none (though he did so as a civilian), and Harry Yarnell played a big part in the air advocates' attempts to wrest control from the blackshoes later in the war.⁶ Chester Nimitz overshadowed them all, but, in actuality, he was more a sympathizer than a proponent – his primary interest lay in air power.

Credit must also be given to a basic element of U.S. Navy policy for this development. Despite the twentieth century trend toward technical specialization, the navy pursued an aggressive strategy of rotating officers through a wide variety of assignments. As a result many officers received exposure to submarines and many submarine officers had extensive experience with surface ships. When key SOC chairman Robert English was grilled by the General Board in 1936 as he set out to bury

⁶ McBride, *Technological Change*, 205-9. Land was also a major air proponent. Hart has been judged harshly for his failure to stop the Japanese onslaught in Asia in 1942. Nevertheless, he did much to advance the cause of submariners in his early years, and he had the good sense not to stand in their way when he chaired the General Board. In his tenure as commander of the Asiatic Fleet, Hart was largely a victim of circumstances. He had very little to work with, his orders were vague, his submarines went to sea with mostly defective torpedoes, and he had few political skills, while his army counterpart (MacArthur) was a consummate politician. Ultimately he was a victim of a critical flaw in the American Pacific Ocean war plans: defend the Philippines with wholly inadequate forces. Leutze, *A Different Kind of Victory*, 147-251; Miller, *War Plan Orange*.

the old fleet submarine role, the fact that he had spent five years navigating battleships and four years teaching at the naval academy gave him credibility he would not otherwise have had. No one could tell him he could not appreciate the blackshoe perspective.

Despite these points, it would not do to overstate the importance of submariners in leadership roles. There is no question that battleship advocates still ran the fleet in 1941 and submariners were still a long way from being even the third most important arm of the fleet. But the gradual changes in leadership created an environment that was conducive to the submarine's quietly assuming an independent role as a commerce raider. Of course, acceptance of the submarine would have occurred even more rapidly if not for the negligence of BUORD. The fact that BUORD did not supply reliable torpedoes to the navy's submarines until 21 months into the war was testament to the efficiency of that organization.⁷

The failure to establish a unified submarine command, such as Yates Stirling's BUSUBS, left something of a void in the Navy Department's organization. As a result, submarine advocates began to seek consensus across organizational lines. The submarine operators, key bureau engineers, and the War Plans Division coalesced into the SOC, which filled that void and in so doing, became the de facto leader of submarine development. As stated earlier, this was rather remarkable considering the relatively low rank of the conference members. But by establishing a network that tapped all the critical sources of submarine knowledge, they formed something that was almost as powerful as a dedicated bureau.

⁷ Clay Blair, *Silent Victory: The U.S. Submarine War against Japan* (Philadelphia: Lippincott, 1975; Annapolis: Naval Institute Press, 2001), 273-81; 435-39. Moreover, as Blair stated, "Each defect had to be discovered and fixed in the field – always over the stubborn opposition of BUORD."

By the time the SOC had seized control of submarine design, it was too late for them to be deflected by returning pioneers like Hart and Land. Land did not try, as he was satisfied with the fleet boat's evolution, but Hart still longed for his efficient little German cruisers and mobilization boats (though he never put it in those terms).⁸ It was too late for that. Submarine officers would not accept small, cramped vessels that taxed their crews' abilities and patience on long cruises in sweltering tropical heat.

The growth of the SOC also had another crucial benefit: it mitigated the Navy Department's organic line officer-engineer rivalry. Though the competition was heated at times, the differences between the two gradually receded as time went on. As discussed in Chapter IX, the most significant disagreements initially were over the size of the submarine and the value of German technology. The constructors were on the wrong side of this issue, but their opinions were a useful counterweight to those who wanted to design a much smaller submarine. While it made a lot of technical sense to do so, it would probably have been a bad idea to force American sailors into German-style boats.

Thus, the rivalry culminated in a fortuitous compromise, one where both sides were off the mark at the outset, but the end result was a very good, possibly ideal, solution. That the compromises came together around 1932 was a stroke of luck. The massive rearmament initiated by Roosevelt in 1933 imbued the submarine community with a distinct sense of urgency. This is not to diminish the importance of subsequent arguments between the parties, but there was a noticeable change in tenor in 1933. The line officer-engineer rivalry still surfaced from time to time, but it was usually confined

⁸ "Mobilization boat" was the German term for various standardized U-boat designs that were produced quickly and in large quantities during the First World War. The German Type VII was the Second World War equivalent.

to disputes over engineering details. Harold Bowen and Joseph DeFrees's duel over the HOR engines provides the best example.

No review of weapon development can be considered complete without an examination of the relationship between the weapon and its mission. In any rational weapon development model, mission is supposed to influence, if not dominate, the growth of the weapon. American submarines were ultimately used for unrestricted commerce warfare, but that was held to be illegal throughout the entire interwar period.

The legal status of submarines and the American reaction to the German commerce warfare campaign of the First World War created a peculiar cultural constraint on the development process. Over most of the interwar period submarine advocates developed their technology well away from the scrutiny of the public, the press, and even many authorities within the navy. In that sense their routine activities were well insulated from those pressures. However, on a more global level, these cultural factors created constraints that not just submarine advocates, but all decision makers in the navy, had to heed. The sources are replete with allusions to commerce warfare, but the actors were always careful to avoid endorsing an unrestricted warfare role. No doubt many discussions on the topic were held "not for the record," as such sidebars are identified in the minutes of meetings before the General Board. The submarine debate was framed around these constraints, and that is why so many searches for evidence that the navy was preparing for commerce warfare in the interwar period have been fruitless. This may also help explain why the navy always portrayed submarines as an integral part of the battle fleet. Not only did battleship advocates believe that was the proper role, they really had no other viable alternative. Many perceptive submarine officers foresaw the future

commerce warfare mission with surprising clarity, but, in light of the interwar political climate, how could they have explained that to Congress?

Submarine designers recognized their dilemma early on, but what they also must have recognized is that a submarine capable of independent cruising operations could be used to attack warships or commerce, the latter either with or without warning. It simply did not affect the technical requirements of the vessel that much. The broad mission of long-range independent operations was sufficient to guide the engineers.

By 1935 the major attributes of the fleet boat were set. Size, range, armament, and speed changed remarkably little in the late 1930s and beyond. But this result was not preordained, for there was considerable haggling behind the scenes over technical details that affected propulsion plant design and the submarine's size and complexity. The vacillation over composite, direct, and electric drive illustrates how the vagaries of politics, personality, and personnel can affect important engineering decisions. A rational engineering study of technical tradeoffs alone would have led to the selection of direct drive, as it did in Germany, Japan, and Great Britain, or at least composite drive. But direct and composite drives were backed exclusively only by Hart, who implicitly threatened the SOC's mandate. Additionally, electric drive was modern and relatively easy to operate, and officers thought it would be the best fit for their crews. The majority obviously thought ease of operation and engine reliability were paramount, because in the end, the navy selected a propulsion system that was heavier, less powerful, more expensive, less survivable, and still dependent on the new high-speed engines.

Despite its importance it would be a reach to say that electric drive was essential to the development of an effective submarine design. In reality composite or direct drive

would have been a viable propulsion system. But the adoption of electric drive in the American “fleet boats” does reinforce the point that technological growth can be just as dependent on the nature of people and their organizations as it can be on machines.

The evolution of the engine design that was indispensable to electric drive stands out as the most critical technological influence on submarine development. More than anything, the high-speed engine instilled motive reliability in the American submarine, and the key to that development was the free market. Business and technology historian Albert J. Churella argues that the cause and effect were reversed. He instead contends that the navy contracts were GM’s primary motivation for pouring so much money into the development of this engine.⁹ This is unlikely. As discussed in Chapter VIII, GM’s Eugene Kettering readily acknowledges that the navy 201 engine and its descendants were a stepping-stone to the locomotive application realized by the 567.¹⁰ Indeed, GM engineers used the 201 as an example of what *not to do* when developing the 567.¹¹ Some production data will demonstrate the point. Between 1935 and 1940 the navy ordered about twenty-six engines per year for its submarines, most of them from GM.¹² Though rearmament was in full swing, it was 1940 before that rate significantly increased, in the wake of the 70 Percent Expansion Act. However, the navy was also splitting its orders more evenly among the three engine makers, so until 1940, each builder was getting at best half of the orders, or thirteen engines per year. In the late

⁹ Churella, *From Steam to Diesel*, 41.

¹⁰ The fact that the 567 was later used in another marine application (LSTs) was a coincidence.

¹¹ Kettering, *The 567 Engine*, 14-15.

¹² This estimate is developed from the number of engines ordered per ship, also conservatively assuming that two spare engines were ordered each year.

1930s, there were about 40,000 railroad locomotives operating in the United States alone, the overwhelming majority of which were powered by steam engines.¹³ It was also plain to unbiased observers at GM and Fairbanks-Morse that diesel-electric locomotives were the future of the industry. Clearly, the size of the commercial market was an order of magnitude greater than the navy market, and that is the real reason that GM and Fairbanks-Morse invested so much in the high-speed engine.¹⁴

Many in the navy were fond of saying that the navy led the development of the high-speed engine, due to the government-sponsored engine competition won by GM in 1932. Those in BUENG probably knew better. What can be said of the navy, however, is that it was a proactive and well-educated customer. BUENG recognized the massive potential of American industry and positioned itself to exploit it. Thus the American fleet boat that hunted the Japanese merchant marine to the point of extinction by 1945 owed much of its success to the American railroad market.¹⁵ It was probably one of the few occasions in history when the performance of a major weapon was so dependent upon the free market.

¹³ Also recognize that large diesel locomotives required more than one engine; the largest locomotives required four, the same as a submarine. Between 1942 and 1955, American companies manufactured about 23,000 diesel locomotives. This equates to 1667 locomotives per year, or 3334 engines per year assuming an average of two engines per locomotive. See Marx, "The Diesel Electric-Locomotive Industry," 33.

¹⁴ Although the War Production Board allowed Fairbanks-Morse to begin building engines for locomotive service in late 1944, GM's first mover status, its technical innovations, and its superior business practices eventually forced Fairbanks-Morse to exit the business in 1959. See Churella, *From Steam to Diesel*, 89-92; 121-26.

¹⁵ American submarines sank over 1,300 Japanese merchant ships, displacing a total of 5.3 million tons, during the course of the Pacific war. An additional 3 million tons of shipping was lost to aircraft and other causes. The Japanese built or acquired 9.5 million tons of merchant shipping by 1945. Thus, 87% of all Japanese shipping was sunk, 62% of it by the American fleet boats. See Clay Blair, *Silent Victory*, 878-79 and SRH-041, "Contribution of the Shipping Section to the Prosecution of the War," 10 October 1945, in Robert Lester, *Top Secret Studies on U.S. Communications Intelligence during World War II, part 3, Organization and Administration* (Bethesda, MD: University Publications of America, 1989), microfilm, 10.

BIBLIOGRAPHY

- Alden, John D. "Development of the High-Speed Diesel Engine for United States Submarines." *Naval Engineers Journal* 91 (August 1979): 43-49.
- _____. *The Fleet Submarine in the U.S. Navy: A Design and Construction History*. Annapolis: Naval Institute Press, 1979.
- Anderson, Walter Stratton. "Submarines and Disarmament Conferences." United States Naval Institute *Proceedings* 53 (January 1927): 53-69.
- Blair, Clay. *Silent Victory: The U.S. Submarine War against Japan*. Philadelphia: Lippincott, 1975; Annapolis: Naval Institute Press, 2001.
- Bowen, Harold G. *Ships, Machinery, and Mossbacks: The Autobiography of a Naval Engineer*. Princeton, NJ: Princeton University Press, 1954.
- Boyd, Carl and Akihiko Yoshida. *The Japanese Submarine Force and World War II*. Annapolis: Naval Institute Press, 1995.
- Bryant, Keith L., Jr., ed. *Railroads in the Age of Regulation*. New York: Facts on File Publications, 1988.
- Chandler, Alfred D. *Scale and Scope: The Dynamics of Industrial Capitalism*. Cambridge, MA: Harvard University Press, 1990.
- Churella, Albert J. *From Steam to Diesel: Managerial Customs and Organizational Capabilities in the Twentieth-Century American Locomotive Industry*. Princeton, NJ: Princeton University Press, 1998.
- _____. "Market Imperatives and Innovation Cycles: The Effects of Technological Discontinuities on the Twentieth-Century Locomotive Industry." *Business and Economic History* 27 (Winter 1998): 378-89.
- Connery, Robert H. *The Navy and the Industrial Mobilization in World War II*. Princeton, NJ: Princeton University Press, 1951.
- Cooling, Benjamin Franklin. *Gray Steel and Blue Water Navy: The Formative Years of America's Military-Industrial Complex, 1881-1917*. Hamden, CT: Archon Books, 1979.
- Cope, Harley F. "U.S. Submarines in the War Zone." United States Naval Institute *Proceedings* 56 (August 1930): 711-16.

- Daubin, Freeland. "Cruise of the American *Unterseeboot* 111." United States Naval Institute *Proceedings* 83 (March 1957): 259-71.
- Everitt, Don. *The K Boats: A Dramatic First Report on the World's Most Calamitous Submarines*. New York: Holt, Rinehart, and Winston, 1963.
- Friedman, Norman. *Submarine Design and Development*. Annapolis: Naval Institute Press, 1984.
- _____. *U.S. Submarines through 1945: An Illustrated Design History*. Annapolis: Naval Institute Press, 1995.
- Gabler, Ulrich. *Submarine Design*. Koblenz: Bernard & Graefe Verlag, 1986.
- Headrick, Daniel R. *The Invisible Weapon: Telecommunications and International Politics, 1851-1945*. New York: Oxford University Press, 1991.
- Hovgaard, William. *Structural Design of Warships*. Annapolis: Naval Institute Press, 1940.
- Hughes, Thomas. *Networks of Power: Electrification in Western Society, 1880-1930*. Baltimore: John Hopkins University Press, 1983.
- Huntington, Samuel P. *The Soldier and the State: The Theory and Politics of Civil-Military Relations*. Cambridge, MA: Belknap Press of Harvard University Press, 1957.
- Johns, A. W. "German Submarines." *Transactions of the Institution of Naval Architects* 62 (1920): 19-32.
- Jones, David Louis. *Diesel Engines, Marine-Locomotive-Stationary: A Practical Treatise on the Principle, Construction, Operation, and Maintenance of the Diesel Oil Engine, both Marine and Stationary Types, with a Descriptive Chapter on the Latest Developments in Diesel Locomotives and Diesel Electric Drive for Ship Propulsion*. New York: Norman W. Henley Publishing Company, 1926.
- Kettering, Eugene W. *History and Development of the 567 Series General Motors Locomotive Engine*. LaGrange, IL: General Motors Electro-motive Division, 1951.
- Kirkland, John F. *The Diesel Builders: Fairbanks-Morse and Lima-Hamilton*. Glendale, CA: Interurban Press, 1985.
- Land, Emory Scott. "Submarines in General – German Submarines in Particular." *The Society of Naval Architects and Marine Engineers Proceedings* 29 (November 1919): 111-25.

- _____. *Winning the War with Ships: Land, Sea, and Air – Mostly Land*. New York: Robert M. McBride, 1958.
- Lester, Robert. *Top Secret Studies on U.S. Communications Intelligence during World War II, part 3, Organization and Administration*. Bethesda, MD: University Publications of America, 1989. Microfilm.
- Leutze, James. *A Different Kind of Victory: A Biography of Admiral Thomas C. Hart*. Annapolis: Naval Institute Press, 1981.
- Lipscomb, F. W. *The British Submarine*. Greenwich, UK: Conway Maritime Press, 1975.
- Magdeburger, Edward C. "U.S. Navy Participation in Diesel Engine Development." *Journal of the American Society of Naval Engineers* 49 (November 1937): 590-602.
- Martin, Albro. "Ralph Budd." In *Railroads in the Age of Regulation*, ed. Keith L. Bryant, Jr., 56-60. New York: Facts on File Publications, 1988.
- Marx, Thomas George. "The Diesel-Electric Locomotive Industry: A Study in Market Failures." Ph. D. diss., University of Pennsylvania, 1973.
- McBride, William M. *Technological Change and the United States Navy, 1865-1945*. Baltimore: Johns Hopkins University Press, 2000.
- McVoy, James L., Virgil W. Rinehart, and Prescott Palmer. "The Roosevelt Resurgence (1933-1941)." In *Naval Engineering and American Seapower*, ed. R. W. King, 161-204. Baltimore: Nautical and Aviation Publishing Company, 1989.
- Miller, Edward S. *War Plan Orange: The U.S. Strategy to Defeat Japan, 1897-1945*. Annapolis: Naval Institute Press, 1991.
- Mori, K. *The Submarine in War: A Study of Relevant Rules and Problems*. Tokyo: Maruzen & Co., Ltd., 1931.
- Moy, Timothy. *War Machines: Transforming Technologies in the U.S. Military, 1920-1940*. College Station: Texas A&M University Press, 2001.
- National Archives Building, Washington, D.C.
 Record Group 19: Records of the Bureau of Ships, 1794-1972, Bureau of Engineering General Correspondence, 1923-1940.
 Record Group 80: General Records of the Department of the Navy, 1798-1947; General Board Subject Files, 1900-1947, Secretary of the Navy, Confidential Correspondence, 1919-1927.

- New York Times*. "Our Submarine Wins U-boat Test: United States Type Shows Superiority in Nearly Every Respect." September 7, 1919.
- _____. "Defects are Found in a German Diesel." March 19, 1939.
- Nimitz, Chester W. "Military Value and Tactics of Modern Submarines." United States Naval Institute *Proceedings* 88 (December 1912): 1196-97.
- Nitske, Robert W., and Charles Morrow Wilson. *Rudolph Diesel: Pioneer of the Age of Power*. Norman: University of Oklahoma Press, 1965.
- Potter, E. B. *Nimitz*. Annapolis: Naval Institute Press, 1976.
- Reutter, Mark. "The Lost Promise of the American Railroad." *The Wilson Quarterly* 18 (Winter 1994), 10-25.
- Rickover, H. G. "International Law and the Submarine." United States Naval Institute *Proceedings* 61 (September 1935): 1213-27.
- Robinson, Samuel. "Operations and Trials of the U.S. Fleet Collier *Jupiter*." *Journal of the American Society of Naval Engineers* 26 (1914): 339-53.
- Rössler, Eberhard. *The U-Boat: The Evolution and Technical History of German Submarines*. Translated by Harold Erenberg. Annapolis: Naval Institute Press, 1981.
- Saunders, Harold E. *Hydrodynamics in Ship Design*. New York: The Society of Naval Architects and Marine Engineers, 1957.
- Starks, John F. "German U-Boat Design and Production." *Transactions of the Institution of Naval Architects* 90 (1948): 291-315.
- Stirling, Yates. "Organization for Navy Department Administration: A Study of Principles." United States Naval Institute *Proceedings* 39 (June 1913): 436-99.
- _____. *Sea Duty: The Memoirs of a Fighting Admiral*. New York: G. P. Putnam's Sons, 1939.
- Talbott, J. E. "Weapons Development, War Planning, and Policy: The U.S. Navy and the Submarine, 1917-1941." *Naval War College Review* 37 (May-June 1984): 53-71.
- Tarrant, V. E. *The U-Boat Offensive, 1914-1945*. London: Arms and Armour, 1989.
- Terraine, John. *The U-Boat Wars, 1916-1945*. New York: G. P. Putnam's Sons, 1989.

Thomas, Lowell. *Raiders of the Deep*. Garden City, NY: Doubleday, Doran & Co., Inc., 1928.

Trieber, O. D. "Modern Trend of the Diesel Engine with Respect to Low Weight Per Horsepower, High Revolutions Per Minute and High Mean Effective Pressure." *The Society of Naval Architects and Marine Engineers Proceedings* 37 (November 1927): 235-57.

United States Navy Department, Bureau of Construction and Repair. *History of the Construction Corps of the United States Navy*. Washington D.C.: GPO, 1937.

United States Navy Department, Bureau of Engineering. *History of the Bureau of Engineering, Navy Department, during the World War*. Washington D.C.: GPO, 1922.

United States Navy Department, Bureau of Naval Personnel. *The Fleet Type Submarine, NavPers 16160*. June 1946. Available [Online]:
<<http://www.maritime.org/fleetsub>> [April 14, 2002].

United States Navy Department, Bureau of Naval Personnel. *Submarine Main Propulsion Diesels, NavPers 16161*. June 1946. Available [Online]:
<<http://www.maritime.org/fleetsub/diesel/index.htm>> [April 2, 2002].

United States Navy Operational Archives, Naval Historical Center, Washington, D.C. *Hearings before the General Board of the Navy, 1917-1950*. Wilmington, DE: Scholarly Resources, Inc., 1983. Microfilm.

The Versailles Treaty. June 28, 1919. Available [Online]:
<<http://history.acusd.edu/gen/text/versaillestreaty/vercontents.html>> [March 17, 2002].

Weir, Gary E. "The Navy, Industry, and Diesel Propulsion for American Submarines, 1914-1940." *Naval Engineers Journal* 101 (May 1989): 207-19.

_____. *Building American Submarines, 1914-1940*. Washington D.C.: Department of the Navy, Naval Historical Center, 1991.

_____. "The Search for an American Submarine Strategy and Design, 1916-1936." *Naval War College Review* 44 (Winter 1991): 34-48.

_____. *Forged in War: The Naval-Industrial Complex and American Submarine Construction, 1940-1961*. Washington D.C.: Brassey's, 1998.

APPENDIX A
AMERICAN SUBMARINE CHARACTERISTICS

Table A1. Characteristics of Selected American Submarines Designed between the World Wars

Hull Number ¹	Submarine Name ²	Date Keel Laid	Date Commissioned	Surface Displacement (tons)	Flank Speed Surfaced (knots)	Machinery Layout ³	Main Propulsion Engines Number-MFG HP ⁴	Propulsion Motors Number-MFG HP ⁵
163	<i>Barracuda</i> (V-1)	20-Oct-21	01-Oct-24	2100	18.7	DDD+DED	2-BS 2250 + 2-Bu-MAN 1000	2-EL 1200
164	<i>Bass</i> (V-2)	21-Oct-21	26-Sep-25	2100	18.7	DDD+DED	2-BS 2250 + 2-Bu-MAN 1000	2-EL 1200
165	<i>Bonita</i> (V-3)	16-Nov-21	22-May-26	2100	18.7	DDD+DED	2-BS 2250 + 2-Bu-MAN 1000	2-EL 1200
166	<i>Argonaut</i> (V-4)	01-May-25	02-Apr-28	2700	13.7	DDD+DED	2-Bu-MAN 1400 +1-Bu-MAN 450	2-RDY 1100
167	<i>Narwhal</i> (V-5)	10-May-27	15-May-30	2730	17.4	DDD+DED	2-Bu-MAN 2350 +2-Bu-MAN 450	2-RDY 1100
168	<i>Nautilus</i> (V-6)	02-Aug-27	01-Jul-30	2730	17.4	DDD+DED	2-Bu-MAN 2350 +2-Bu-MAN 450	2-RDY 1100
169	<i>Dolphin</i> (V-7)	14-Jun-30	01-Jun-32	1560	17.3	DDD+DED	2-Bu-MAN 1750 + 2-Bu-MAN 450	2-ED 875
170	<i>Cachalot</i> (V-8)	21-Oct-31	01-Dec-33	1120	17	DDD	2-metric-MAN 1535	2-WH 800
171	<i>Cuttlefish</i> (V-9)	07-Oct-31	08-Jun-34	1120	18	DDD	2-metric-MAN 1535	2-ED 800
172	<i>Porpoise</i> (FY34)	27-Oct-33	15-Aug-35	1310	18.8	DERD	4-GM 1300	4-EL 1075
173	<i>Pike</i> (FY34)	20-Dec-33	02-Dec-35	1310	18.8	DERD	4-GM 1300	4-EL 1075
174	<i>Shark</i> (FY34)	24-Oct-33	25-Jan-36	1316	19.5	DERD	4-GM 1300	4-EL 1075
175	<i>Tarpon</i> (FY34)	22-Dec-33	12-Mar-36	1316	19.5	DERD	4-GM 1300	4-EL 1075
176	<i>Perch</i> (FY35)	25-Feb-35	19-Nov-36	1330	20.1	DERD	4-GM 1300	8-GE 538
177	<i>Pickrel</i> (FY35)	25-Mar-35	26-Jan-37	1330	20.1	DERD	4-GM 1300	8-GE 538

Table A1 – Continued

Hull Number ¹	Submarine Name ²	Date Keel Laid	Date Commissioned	Surface Displacement (tons)	Flank Speed Surfaced (knots)	Machinery Layout ³	Main Propulsion Engines Number-MFG HP ⁴	Propulsion Motors Number-MFG HP ⁵
178	<i>Permit</i> (FY35)	06-Jun-35	17-Mar-37	1330	20.1	DERD	4-GM 1300	8-GE 538
179	<i>Plunger</i> (FY35)	17-Jul-35	19-Nov-36	1330	20.1	DERD	4-FM 1300	4-EL 1090
180	<i>Pollack</i> (FY35)	01-Oct-35	15-Jan-37	1330	20.1	DERD	4-FM 1300	4-EL 1090
181	<i>Pompano</i> (FY35)	14-Jan-36	12-Jun-37	1330	20.1	DERD	4-HOR 1300	4-AC 1091
182	<i>Salmon</i> (FY36)	15-Apr-36	15-Mar-38	1450	21	Composite	4-HOR 1535	4-EL 667
183	<i>Seal</i> (FY36)	25-May-36	30-Apr-38	1450	21	Composite	4-HOR 1535	4-EL 667
184	<i>Skipjack</i> (FY36)	22-Jul-36	30-Jun-38	1450	21	Composite	4-HOR 1535	4-EL 667
185	<i>Snapper</i> (FY36)	23-Jul-36	15-Dec-37	1450	21	Composite	4-GM 1535	4-EL 667
186	<i>Stingray</i> (FY36)	01-Oct-36	15-Mar-38	1450	21	Composite	4-GM 1535	4-EL 667
187	<i>Sturgeon</i> (FY36)	27-Oct-36	25-Jun-38	1450	21	Composite	4-GM 1535	4-EL 667
188	<i>Sargo</i> (FY37)	12-May-37	07-Feb-39	1450	20.5	Composite	4-HOR 1535	4-GE 685
189	<i>Saury</i> (FY37)	28-Jun-37	03-Apr-39	1450	20.5	Composite	4-HOR 1535	4-GE 685
190	<i>Spearfish</i> (FY37)	09-Sep-37	19-Jul-39	1450	20.5	Composite	4-HOR 1535	4-GE 685
191	<i>Sculpin</i> (FY37)	07-Sep-37	16-Jan-39	1450	20.5	Composite	4-GM 1535	4-GE 685
192	<i>Squalus</i> (FY37)	18-Oct-37	01-Mar-39	1450	20.5	Composite	4-GM 1535	4-GE 685
193	<i>Swordfish</i> (FY37)	27-Oct-37	22-Jul-39	1450	20.5	Composite	4-GM 1535	4-GE 685
194	<i>Seadragon</i> (FY38)	18-Apr-38	23-Oct-39	1450	20	DERD	4-HOR 1535	4-GE 685
195	<i>Sealion</i> (FY38)	20-Jun-38	27-Nov-39	1450	20	DERD	4-HOR 1535	4-GE 685

Table A1 – Continued

Hull Number ¹	Submarine Name ²	Date Keel Laid	Date Commissioned	Surface Displacement (tons)	Flank Speed Surfaced (knots)	Machinery Layout ³	Main Propulsion Engines Number-MFG HP ⁴	Propulsion Motors Number-MFG HP ⁵
196	<i>Searaven</i> (FY38)	09-Aug-38	02-Oct-39	1450	20	DERD	4-GM 1535	4-GE 685
197	<i>Seawolf</i> (FY38)	27-Sep-38	01-Dec-39	1450	20	DERD	4-GM 1535	4-GE 685
198-211	FY39/FY40 ^b	16-Jan-39	25-Jan-41	1475	20	DERD	4-GM 1535 or 4-FM 1535	4-GE 1375
212-227	FY41 ^c	05-Oct-40	06-Jun-43	1525	20	DERD	4-GM 1535	4-GE 1375

Notes:

1. *Source: Alden, The Fleet Submarine.*
2. For SS-163 through SS-171, the ship name is followed by the "V" designation that was the original naming convention. For all others, the fiscal year the submarines were authorized in follows the ship name. Ship names are omitted for the last two entries since a series of boats is being described on one line.
3. See fig. 1 for an explanation of the different types of machinery layouts used. Electric drive in its simplest form (engines driving only generators, one motor per shaft, and no reduction gears) was not realized until SS-405 (*Sea Owl*), which was not commissioned until July 17, 1944.
4. BS is Busch-Sulzer, GM is General Motors, FM is Fairbanks-Morse, and HOR is Hooven-Owens-Rentschler. Bu-MAN engines were built by NYNY based on reverse-engineered MAN engines taken from German U-boats of the First World War. Metric-MAN engines were also built by NYNY, but based on plans purchased directly from MAN.
5. EL is Elliot, ED is Electro-Dynamic, RDY is Ridgway, AC is Allis Chalmers, WH is Westinghouse, and GE is General Electric.
6. For groups of ships, the authorization date given is for the first boat in the group and the commissioning date given is for the last boat in the group. Two numbers in this range (SS-204 and SS-205) were used for the 800-ton design that Thomas Hart championed in

Table A1 – Continued

his tenure as chairman of the General Board. Characteristics of those boats are not included in the table. The engine orders for FY39 and FY40 boats were evenly divided between GM and FM.

7. These are the first mass-produced boats built during wartime. The basic characteristics of this group remained remarkably stable until late in the war, as the Americans showed a clear commitment to standardization. Incremental improvements were provided in the form of gradually increased diving depths, improved radar, revised tankage, and other miscellaneous improvements.

8. All boats had four torpedo tubes forward and two aft through SS-181. In SS-182 through SS-197 four tubes were located forward and four were located aft, and all boats thereafter had six tubes forward and four aft. External stowage of some extra torpedoes was common until the war years, when the practice was abandoned.

9. According to Alden, the range of all U.S. submarines beginning with V-8 was standardized at 11,000 miles at 10 knots. Other sources cite the range as high as 13,000 miles for the modern boats. Obviously, range could be extended by cruising at lower speeds, and German submarine cruisers of the First World War often had ranges specified at speeds as low as 5-8 knots to achieve inflated ranges of 15,000 to 25,000 miles. See V. E. Tarrant, *The U-Boat Offensive, 1914-1945* (London: Arms and Armour, 1989), 169-74.

APPENDIX B**A BRIEF COMPARISON OF GERMAN AND AMERICAN SUBMARINE DESIGNS
OF THE SECOND WORLD WAR**

In table B1 the American fleet submarine is compared to the two primary types of submarines used by the German navy during the Second World War. As can be seen from a review of the table, German submarines were considerably smaller. Although the Type VII was not intended to go on missions comparable to the Pacific voyages that the Americans undertook, the boats were often pressed into service in just that role due to expansion of the war, refueling to extend range whenever possible. The Type VII is similar to the small submarine that Thomas Hart tried to convince the SOC to consider in 1937. While he recognized the value of a larger design, he also knew that a medium sized vessel could be built in greater quantity and at a lower cost than the larger American design. This approach was technically and militarily sound but it had three important drawbacks. U.S. Navy engineers and submarine operators considered the habitability compromises, the lower number of torpedo tubes, and the limited range unacceptable. The Type IX is a good model for comparison to the American fleet boat, since it was designed for a similar function. It is notable that the Germans were able to build a submarine that was 28% smaller and yet achieved a cruising radius comparable to the fleet boat, although it did have less offensive capability. Obviously, top speed was not a major consideration for the Germans and they were willing to give up a few knots in exchange for space and weight. The German machinery plants were far smaller than the American ones, since DDD was the most efficient machinery plant layout and because of the lower top speed. Finally, the Germans minimized hotel services and their crews were considerably smaller.

Table B1. A Brief Comparison of German and American Submarine Designs of the Second World War

Characteristic	SS-212 <i>Gato</i> and later	German Type VIIC	German Type IXC
Displacement (tons)	1525	769	1120
Machinery Layout	DERD	DDD	DDD
Number of Motors	4	2	2
Reduction Gears	Yes	No	No
Number of Engines – HP each	4-1535	2-1400	2-2200
Flank Speed (knots)	20.5	17.7	18.3
Torpedo Tubes (FWD/AFT)	6/4	4/1	4/2
Torpedoes Carried ¹	24	12	19
Range (miles)	11,000	7500	12,000
Personnel	80	44	48
Approximate Number Built	250	650	150

Sources: John F. Starks, “German U-Boat Design and Production” *Transactions of the Institution of Naval Architects* 90 (1948): 291-315, and Alden, *The Fleet Submarine*.

1. The Americans initially followed the practice of increasing weapon capacity by carrying some torpedoes in external stowage as the Germans always did, but the process was discontinued primarily because of the danger and ship vulnerability associated with crews shipping weapons on the surface unassisted. Rigging weapons into the boat unassisted was time consuming and dangerous. The weapons were difficult to handle at sea, particularly without the hoisting and rigging tools available from a submarine tender or in port. The submarines were vulnerable to air attack for several hours while sailors removed the weapons from their stowage locations and guided them through hatches into the torpedo rooms, all of which had to be done on a pitching deck if the seas were not calm.

VITA

Stephen J. Brady received a B.S. in Mechanical Engineering from the University of New Orleans in December 1979. In August 1997, he began taking courses offered by the History Department at Old Dominion University, Batten Arts and Letters, Room 800, Norfolk, Virginia, 23529-0091. Mr. Brady expects to receive an M.A. in History from Old Dominion University in August 2002. Mr. Brady was inducted into the Old Dominion University chapter of the Phi Alpha Theta honor society in 2000.

In 1980 Mr. Brady joined Newport News Shipbuilding (NNS) as an Associate Engineer working on the design of piping components and various deck machinery on submarines, aircraft carriers, and guided-missile cruisers. In 1984 Mr. Brady was promoted to Senior Engineer and assigned to the Aircraft Carrier Design and Construction Project.

Since 1989 Mr. Brady has served as an Engineering Supervisor in the Submarine Machinery Engineering Department at NNS. He has primarily been involved in the design and maintenance of weapon launching systems, structural hatches, and auxiliary launchers on *Los Angeles*, *Seawolf*, and *Virginia* Class submarines. His areas of concentration include machine design, materials, and shock and vibration analysis.