

Old Dominion University ODU Digital Commons

Physics Faculty Publications

Physics

2017

Compact Crabbing Cavity Systems for Particle Colliders

Subashini De Silva
Old Dominion University

Follow this and additional works at: https://digitalcommons.odu.edu/physics_fac_pubs

 Part of the [Engineering Physics Commons](#)

Repository Citation

Silva, Subashini De, "Compact Crabbing Cavity Systems for Particle Colliders" (2017). *Physics Faculty Publications*. 316.
https://digitalcommons.odu.edu/physics_fac_pubs/316

Original Publication Citation

De Silva, S. (2017, October 9-14, 2016). *Compact Crabbing Cavity Systems for Particle Colliders*. Paper presented at the North American Particle Accelerator Conference, Chicago, Illinois.
<https://doi.org/10.18429/JACoW-NAPAC2016-WEB2IO02>

This Conference Paper is brought to you for free and open access by the Physics at ODU Digital Commons. It has been accepted for inclusion in Physics Faculty Publications by an authorized administrator of ODU Digital Commons. For more information, please contact digitalcommons@odu.edu.

COMPACT CRABBING CAVITY SYSTEMS FOR PARTICLE COLLIDERS*

S. U. De Silva

Center for Accelerator Science, Old Dominion University, Norfolk, VA 23529, USA

Abstract

In circular or ring-based particle colliders, crabbing cavities are used to increase the luminosity. The first superconducting crabbing cavity system was successfully implemented at KEKB electron-positron collider that have demonstrated the luminosity increase with overlapping bunches. Crabbing systems are an essential component in the future colliders with intense beams, such as the LHC high luminosity upgrade and proposed electron-ion colliders. Novel compact superconducting cavity designs with improved rf properties, at low operating frequencies have been prototyped successfully that can deliver high operating voltages. We present single cavity and multi-cell crabbing cavities proposed for future particle colliders and addresses the challenges in those cavity systems.

INTRODUCTION

Luminosity increase in particle colliders requires maximizing the number of interactions between the colliding bunches. Non-overlapping bunches limit the number of interactions to that crossing angle as given in

$$L = \frac{N_1 N_2 f_c N_b}{4\pi\sigma_x\sigma_y} \frac{1}{\sqrt{1 + \left(\frac{\sigma_z\theta_c}{2\sigma_x}\right)^2}} \quad (3)$$

where θ_c is the crossing angle. This limitation can be overcome by using crabbing cavities to enable head-on collision of bunches. The crabbing concept was first proposed by R.B. Palmer [1], in using a rf cavity to generate a transverse kick at the head and tail of the bunch that forces head-on collision at the interaction point of the colliding bunches as shown in Fig. 1.

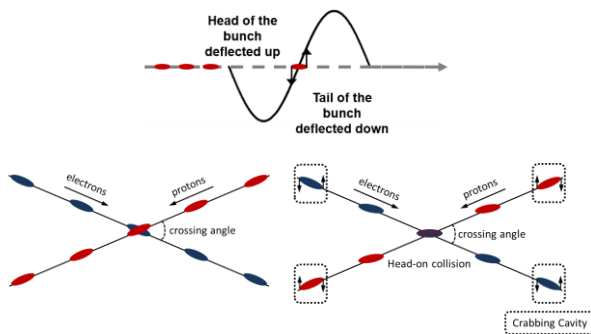

Figure 1: Transverse kick due to crabbing cavity (top) and bunch collision with and without crabbing cavities (bottom).

*Work supported by DOE via US LARP Program and by the High Luminosity LHC Project. Work was also supported by DOE Contract No. DE-AC02-76SF00515.
#sdesilva@jlab.org

Crabbing cavities can be used as an rf separator in splitting a single beam to multiple beams; operating at a phase offset of $\pi/2$. These cavities operating in crabbing mode can also be used in emittance exchange in beams, x-ray pulse compression, and beam diagnostics.

TM₁₁₀-TYPE CAVITIES

Crabbing cavities operating in TM₁₁₀ mode uses the transverse magnetic field interaction with the beam to generate transverse kick as shown in Fig. 2 [2]. The TM₁₁₀ mode is degenerate in a cylindrical-shaped geometry; therefore a squashed-elliptical geometry is adapted to separate the two polarizations.

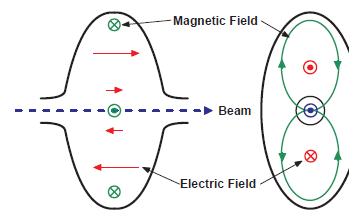

Figure 2: Squashed-elliptical crabbing cavity operating in TM₁₁₀ mode.

The squashed-elliptical cavity has a lower order mode (LOM), which is the TM₀₁₀ monopole mode present in the geometry. The narrow separation between the crabbing mode with LOM and HOMs while maintaining high R/Q for the crabbing mode makes the damping scheme very complex for these cavities. The operating frequency is inversely related to the transverse dimensions, hence these shapes are not favourable at low operating frequencies. At high operating frequencies TM₁₁₀-type cavities can deliver compact crabbing cavities that are capable of accommodating large beam apertures. The degrees of freedom in the parameter space for TM₁₁₀-type cavities are limited, which makes the suppression of higher order multipole components difficult.

1st Superconducting Crabbing Cavity

The first and only superconducting crabbing cavity has been designed and developed at KEK for the KEKB factory [3].

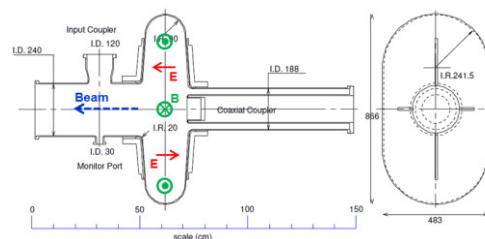

Figure 3: 508.9 MHz KEK crabbing cavity.

Two crabbing cavity systems has been installed at each of the high and low energy rings and was in operation during 2007–2010. The crabbing cavity design was a TM_{110} -type cavity operating at 508.9 MHz as shown in Fig. 3. The cavity used a coaxial coupler to damp the lower order modes and TE_{11} -type higher order modes.

Crabbing Cavity for SPX Project

The proposed short pulse x-ray (SPX) project at ANL had required a crabbing cavity operating at 2.815 GHz. Two TM_{110} -type crabbing cavity designs have been developed at JLab as shown in Fig. 4 [4, 5].

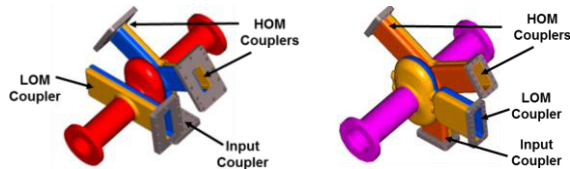

Figure 4: 2.815 GHz crabbing cavities: MARK I – Baseline design (left) and MARK II – Alternate design (right).

MARK I cavity was designed with an LOM coupler located on the beam pipe and MARK II cavity used an on-cell LOM coupler. At high operating frequency the TM_{110} -type cavities are capable of accommodating a large beam aperture of 50 mm. The cryogenic tests of both cavities have achieved the design requirement of 0.5 MV.

CRABBING CAVITY APPLICATIONS

Recent crabbing cavity applications are in need of compact crabbing cavity designs due to tight dimensional constraints and strict design specifications. LHC high luminosity upgrade is one of the current collider applications that will be using compact crabbing cavities at two the interaction points of ATLAS and CMS experiments [6]. Jefferson lab electron-ion collider (JLEIC) and eRHIC at BNL are two future collider applications that are considering compact crabbing cavities.

The operating frequency of the crabbing cavities is 400.79 MHz where the transverse dimensions of the cavities are required to be less than 290 mm due to the beam pipe separation of 194 mm as shown in Fig. 5.

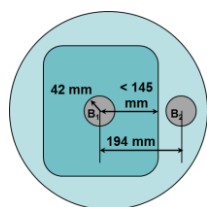

Figure 5: Beam pipe separation for the LHC ring at CERN.

A TM_{110} -type cavity operating at 400 MHz is comparatively large and is not a feasible design for LHC high luminosity upgrade crabbing cavities. Therefore, alternate designs are considered operating TEM-like modes or TE-like modes as shown in Fig. 6. TEM-like cavities uses both electric and magnetic field in generating

the transverse kick and in TE-like cavities the contribution to the transverse kick is mostly due to the transverse electric field.

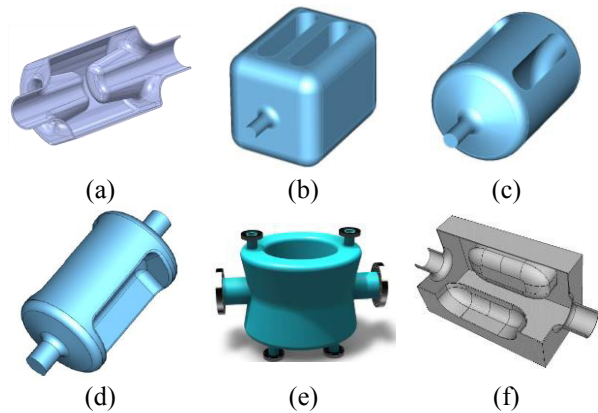

Figure 6: TEM-like designs: (a) 4-rod cavity (University of Lancaster, UK), (b)-(c) parallel-bar cavities (ODU). TE-like designs: (d) rf-dipole cavity (ODU), (e) double quarter wave cavity (BNL), (f) ridged-wave cavity (SLAC).

TEM-LIKE CAVITIES

4-Rod Cavity

The 4-rod cavity consists of 4 quarter-wave resonators where the combination of the 4 rods gives 4 same order modes as shown in Fig. 7. The 3rd mode is the crabbing mode and 1st mode is the accelerating mode that has a lower frequency.

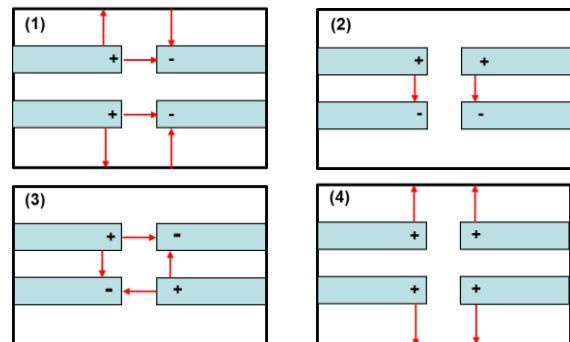

Figure 7: Electric field configuration of the four similar order modes in the 4-rod geometry.

The superconducting 4-rod cavity is adapted from the 499 MHz normal conducting rf separator at Jefferson Lab [7]. The new geometry has improved rod geometry of $\lambda/4$ length as shown in Fig. 8 [8]. The surface electric and magnetic field profiles are shown in Fig. 9.

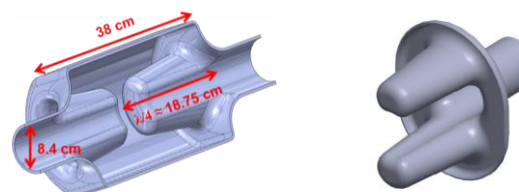

Figure 8: 400 MHz superconducting 4-rod cavity.

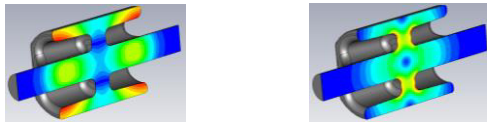

Figure 9: Surface magnetic (left) and electric field (right) of the 4-rod cavity crabbing mode.

Parallel-Bar Cavity

The parallel-bar cavity operating in TEM-like mode has two degenerate modes (0 mode and π mode) where π mode is the deflecting mode where the transverse kick is generated by both transverse electric and magnetic fields [9]. Several iterations of parallel-bar cavities have been designed in improving the rf properties. The design has been evolved into a TE-like design called the rf-dipole cavity as shown in Fig. 10 [10].

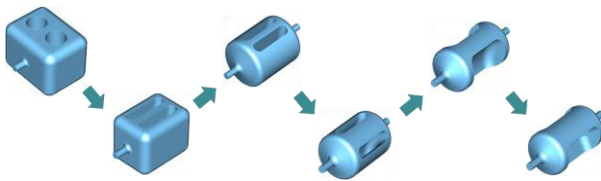

Figure 10: Evolution of the parallel bar cavity in to rf-dipole cavity.

TE-LIKE CAVITIES

RF-Dipole Cavity

The rf-dipole cavity operates in TE₁₁-like mode where primary contribution to the transverse kick is from the transverse electric field. The field profiles are shown in Fig. 11. Crabbing mode do not exist in pure TE₁₁ mode as the resultant kick due to transverse electric is cancelled by the kick due to magnetic field.

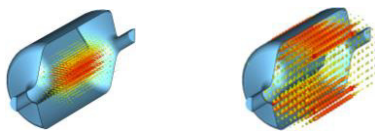

Figure 11: Electric (left) and magnetic (right) field profile of rf-dipole cavity.

Ridged Waveguide Cavity

Similar cavity design was proposed by Zenghai Li at SLAC named the ridged waveguide cavity operating in TE-like mode as shown in Fig. 12 [11].

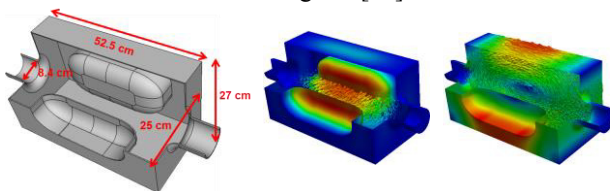

Figure 12: Ridged waveguide cavity (left) with electric (middle) and magnetic (right) field profiles.

Double Quarter Wave Cavity

The double quarter wave cavity from BNL [12] shown in Fig. 13, is one of the TE-like crabbing cavities with a strong transverse electric field that generates a transverse kick.

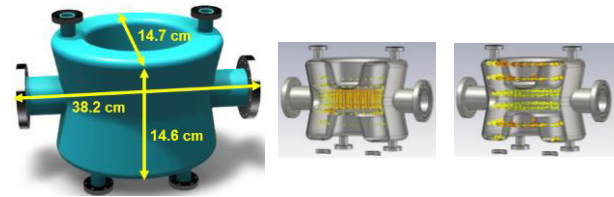

Figure 13: Double quarter wave cavity (left) with electric (middle) and magnetic (right) field profiles.

In TEM-like cavities frequency is dependent on the longitudinal dimensions and transverse dimensions are not depended on the frequency. Therefore, these designs can accommodate low operating frequencies with small transverse sizes. On contrary, in TE-like cavities the transverse dimensions are inversely related to the frequency, which is also favourable in low frequency applications. As the length is not dependent on the frequency these cavities can accommodate applications with low-velocity particles that wouldn't be feasible with TEM-like cavities.

PROPERTIES OF TEM-LIKE AND TE-LIKE CAVITIES

The 4-rod cavity, double quarter wave cavity and rf-dipole cavity operating at 400 MHz have been considered as the crabbing cavities for the LHC high luminosity upgrade. The designs have been modified with improved rf properties. The rf properties of the three geometries are listed in Table 1.

Table 1: RF Properties of the 400 MHz (a) 4-rod Cavity, (b) Double Quarter Wave Cavity and (c) Rf-dipole Cavity.

Parameter	(a)	(b)	(c)	Units
LOM	375.2	None	None	MHz
Nearest HOMs	436.6, 452.1	590	633.5	MHz
V_t	3.4	3.4	3.4	MV
E_p	36	41	33	MV/m
B_p	69	71	57	mT/(MV/m)
G	62.8	89	107	Ω
$[R/Q]_t$	915	430	430	Ω
$R_t R_s$	5.7	3.8	4.6	$\times 10^4 \Omega^2$

HOM Damping

The 4-rod cavity configuration of HOM couplers are shown in Fig. 14. The accelerating mode which is a lower order mode present in the cavity is damped using a notch filter. Two higher order mode HOM couplers (H-HOM & V-HOM) damps the dipole modes in horizontal direction and vertical direction.

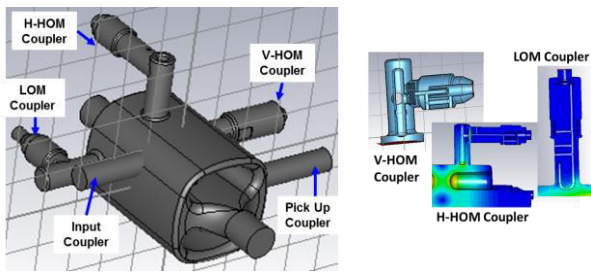

Figure 14: HOM coupling of 4-rod cavity.

Unlike TEM-like cavities, TE-like cavities do not have any lower order modes present in those geometries. The HOM damping for the two TE-like cavities are shown in Figs. 15 and 16.

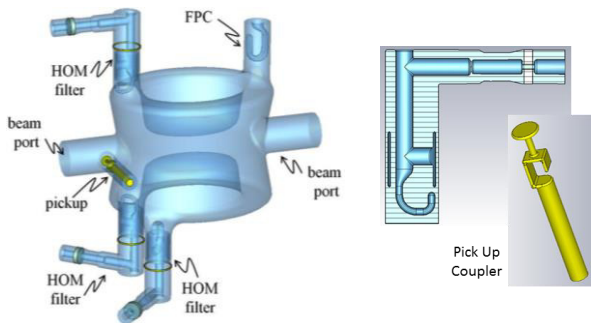

Figure 15: HOM coupling of double quarter wave cavity.

The HOM damping of the double quarter wave cavity was designed with 3 identical HOM couplers as shown in Fig. 15 [13]. The HOM coupler is a filter that cuts-off the fundamental crabbing mode. The pickup coupler is used to damp the HOM at 1.75 GHz.

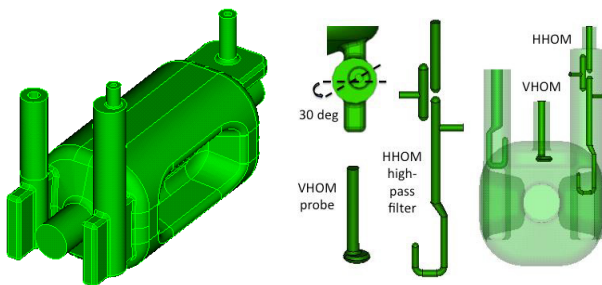

Figure 16: HOM damping of rf-dipole cavity.

The rf-dipole cavity uses only two HOM couplers: a high pass filter (HHOM) that couples to the horizontal dipole modes and a vertical coax coupler (VHOM) that couples to the dipole modes in vertical direction [14]. The rotated HHOM coupler and the skewed VHOM probe strongly damps few of the HOMs near 2 GHz.

Multipacting Analysis

Extensive multipacting analysis was performed to identify resonant conditions on these novel crabbing cavity designs. Multipacting levels were studied using the Track3P code of SLAC ACE3P suite [15]. Predicted multipacting levels shown in Fig. 17 were observed in both

the crabbing cavities during the cryogenic tests and were easily processed.

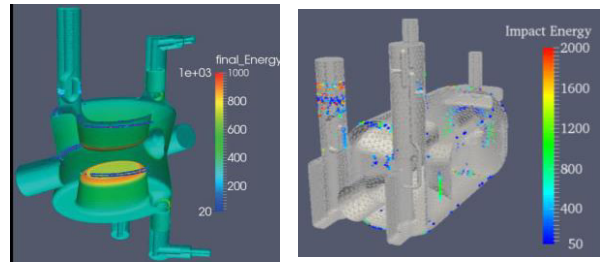

Figure 17: Multipacting levels of double quarter wave cavity (left) and rf-dipole cavity (right).

Higher Order Multipole Analysis

In circular particle colliders high order multipole components are required to be low in order to minimize beam effects. The non-uniform transverse fields across the beam aperture give rise to the higher order multipole components in TEM-like and TE-like crabbing cavities. Compared to TM₁₁₀-type cavities these compact crabbing cavities have more degrees of freedom in parameters that can be used to reduce the higher order multipole components. The capacitive plates along the beam aperture was curved inward as shown in Fig. 18.

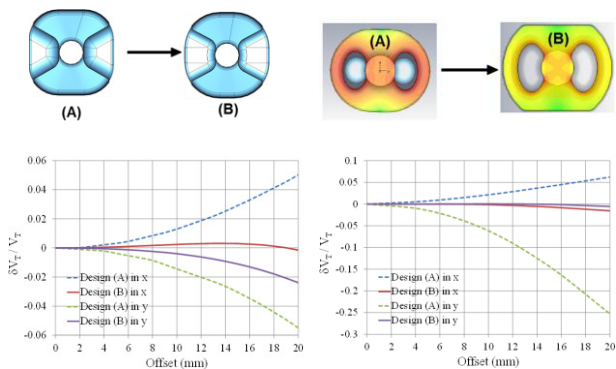

Figure 18: Field non uniformity of rf-dipole cavity (left) and 4-rod cavity (right).

CRYOGENIC TESTS OF PROOF-OF-PRINCIPLE CAVITIES

The proof-of-principle cavities of the 4-rod cavity double quarter wave cavity, and rf-dipole cavity shown in Fig. 19 were fabricated at Niowave Inc..



Figure 19: Proof-of-principle cavities: 4-rod cavity (left), double quarter wave cavity (middle), and rf-dipole cavity (right).

Cryogenic test results of the three cavities are shown in Fig. 20. The 4-rod cavity was tested at CERN and achieved the design requirements of 3.4 MV. The double quarter

wave cavity was tested at BNL also achieved the design specifications. The rf-dipole cavity was tested at JLab surpassed the design specifications with a transverse kick of 7.0 MV and Q_0 of 1.2×10^{10} .

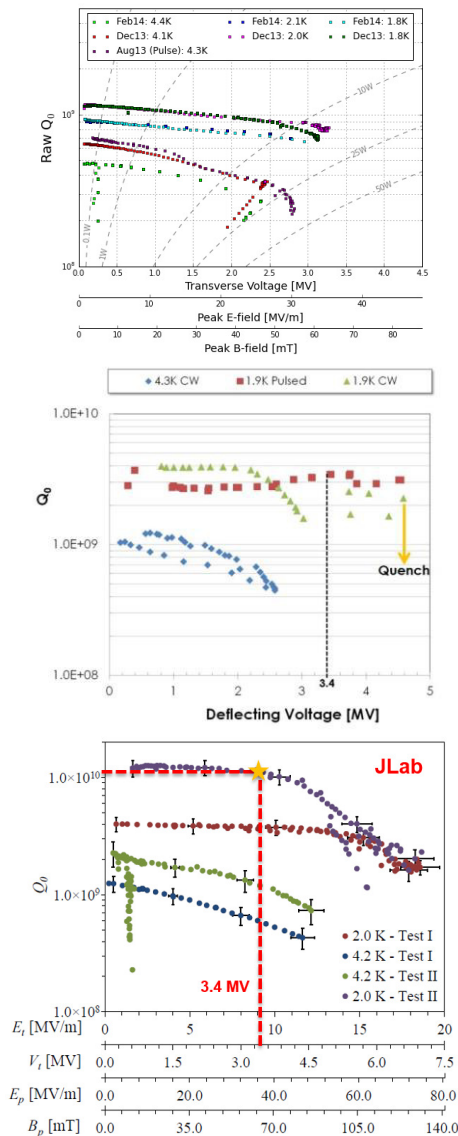

Figure 20: Cryogenic test results of 4-rod cavity (top), double quarter wave cavity (middle), and rf-dipole cavity (bottom).

CAVITY ENGINEERING AND PROTOTYPING

The crabbing cavities for LHC high luminosity upgrade is expected to be tested at SPS prior to installation at LHC. The cryomodule designs are underway at CERN for the two crabbing cavities [16]. Currently prototype cavities are being fabricated. The two cryomodule designs are shown in Fig. 21.

REFERENCES

[1] R. B. Palmer, "Energy scaling, crab crossing and the pair problem," Tech. Rep. SLAC-PUB-4707, 1988.

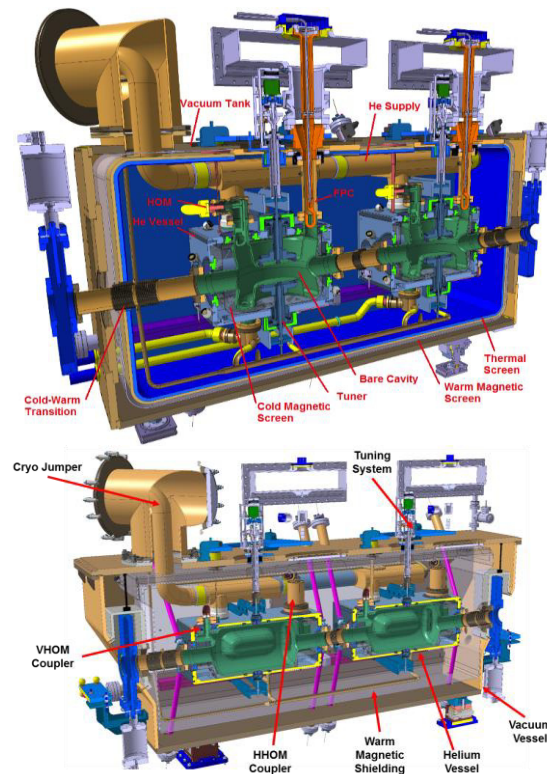

Figure 21: Cryomodule design for double quarter wave cavity (top) and rf-dipole cavity (bottom).

- [2] G. Burt, "Transverse deflecting cavities," Tech. Rep. arXiv:1201.2600, CERN, 2012.
- [3] K. Hosoyama *et al.*, in *Proc. of the 7th Workshop on RF Superconductivity*, p. 547, 1998.
- [4] H. Wang, "SPX Crab Cavity Development and Testing Result," TTC Meeting, 2012.
- [5] J. Mammosser, "Cryomodule Design," APS-U Lehman Review, 2011.
- [6] R. Calaga, in *Proc. Chamonix Workshop on LHC Performance*, Chamonix, Switzerland, p. 363, 2012.
- [7] C. Leeman and C.G. Yao, in *Proc. 1990 Linear Accelerator Conference*, p. 232, 1991.
- [8] B. Hall, "LHC-4R Crab Cavity," EUCARD SRF Annual Review, March 2012.
- [9] J.R. Delayen and H. Wang, *Phys. Rev. Accel. Beams* vol. 12, p. 062002, 2009.
- [10] S.U. De Silva and J. R. Delayen, *Phys. Rev. Accel. Beams*, vol. 16, p. 012004, 2013.
- [11] Z. Li and L. Ge, "Compact Crab Cavity Design and Modeling Using Parallel Code" *ACE3P*, LHCC11, 2012.
- [12] B. Xiao, *et al.*, *Phys. Rev. Accel. Beams*, vol. 18, p. 041004, 2015.
- [13] B. Xiao, in *Proc. SRF 2015*, Whistler, BC, Canada, p. 1031, 2015.
- [14] Z. Li, *et al.*, in *Proc. IPAC 2015*, Richmond, VA, USA, p. 3492, 2015.
- [15] K. Ko, *et al.*, in *Proc. LINAC 2010*, Tsukuba, Japan, p.1028, 2010.
- [16] F. Carra, *et al.*, in *Proc. SRF 2015*, Whistler, BC, Canada, p. 1460, 2015.