

Pittsburg State University

## Pittsburg State University Digital Commons

---

Paper and Posters Presentations

Research Colloquium 2017

---

4-2017

### Reverse Hyperextension Device

Nayeli Feregrino

*Pittsburg State University*

Aziz Alotaibi

*Pittsburg State University*

Gage Becker

*Pittsburg State University*

Kyle Brown

*Pittsburg State University*

Dillon Fleming

*Pittsburg State University*

Follow this and additional works at: [https://digitalcommons.pittstate.edu/papers\\_2017](https://digitalcommons.pittstate.edu/papers_2017)



Part of the [Mechanical Engineering Commons](#)

---

#### Recommended Citation

Feregrino, Nayeli; Alotaibi, Aziz; Becker, Gage; Brown, Kyle; and Fleming, Dillon, "Reverse Hyperextension Device" (2017). *Paper and Posters Presentations*. 1.

[https://digitalcommons.pittstate.edu/papers\\_2017/1](https://digitalcommons.pittstate.edu/papers_2017/1)

This Presentation is brought to you for free and open access by the Research Colloquium 2017 at Pittsburg State University Digital Commons. It has been accepted for inclusion in Paper and Posters Presentations by an authorized administrator of Pittsburg State University Digital Commons. For more information, please contact [mmccune@pittstate.edu](mailto:mmccune@pittstate.edu), [jmauk@pittstate.edu](mailto:jmauk@pittstate.edu).

# REVERSE HYPEREXTENSION DEVICE

Pittsburg State University

Senior Project WF16/SP17





# Group members

 Abdulaziz Alotaibi

➤ *MET - Design*

 Gage Becker

➤ *MET - Design*

 Kyle Brown

➤ *MET - Design*

 Nayeli Feregrino

➤ *MET - Manufacturing*

 Dillon Fleming

➤ *MFGET*

 **Customer**

➤ *Dr. Derek Crawford, HHPR*



# Background Information

- A Reverse Hyperextension device, sometimes called Reverse Hyper or RHD is generally designed to help those with lower back problems who can no longer do squats because of the strain that comes from them.
- The RHD presents the option to work out the same muscles that squats focus on, without having the added force of gravity acting upon the person's back.



# Design Inputs

Reverse Hyperextension Device				
Input	Nominal Value	Tolerance	Rationale	Scale
Collapsible	3' x 10' x 7'	max	Size of usable storage space	10
Width	3'	max	Size of usable storage space	-
Length	10'	max	Size of usable storage space	-
Height	7'	max	Size of usable storage space	-
Assembled Footprint Dimensions	5' x 5.5' x 5.5'	max	Size of functioning space	10
Width	5'	max at rest	Size of functioning space	-
Length	5.5'	max at rest	Size of functioning space	-
Height	5.5'	max at rest	Size of functioning space	-
Movable by one person	70 lb	max	Max weight for UPS package to be lifted safely/individually <sup>1</sup>	10
Stability	Present	N/A	Utilize Solidworks Stability study	10
Time to assemble or disassemble	10 min.	max	Requirement for use; time between classes	8
Tools needed for assembly	3	max	Requirement for use; device function	5
Weight Device can support user	300 lb Person	max	Customer Requirement, user safety	10
Weight Device can support plate weight	250 lb Plates	max	Customer Requirement, user safety	10

# Design Inputs

Size range of user	4'-10" - 6'5"	max/min	5th percentile female <sup>2</sup> - Specified by customer	10
Pendulum range of motion (0° is at resting point)	90° extension	min	Customer Requirement	10
	30° flexion	min	Customer Requirement	10
Cleanable Surfaces with alcohol	Present	N/A	Customer Requirement; 70% Isopropyl Alcohol	7
Angular position readout	Present	5° increments	Customer Requirement, for data analysis	6
Scratch Resistant Feet	Present	N/A	Design team requirement	2
How-to-Use Manual	Present	N/A	Customer Requirement, user safety	10
Paint	Present	N/A	Design team requirement	5
Clean weld beads	Present	N/A	Design team requirement	5
<b>Safety</b>				
No sharp points	Present	N/A	User Safety	10
Minimize or label pinch points	Present	N/A	User Safety	10

# Initial Ideas

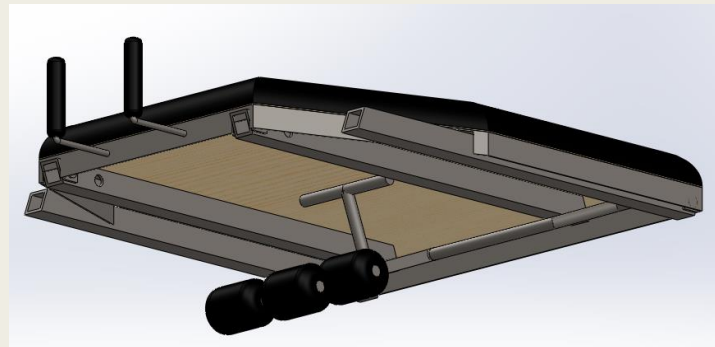
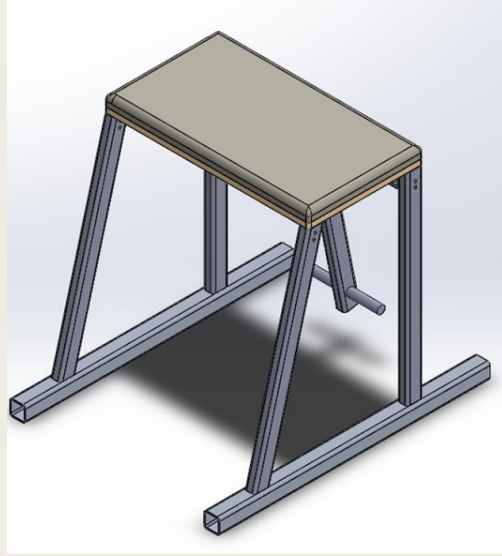

# Final Frame Design

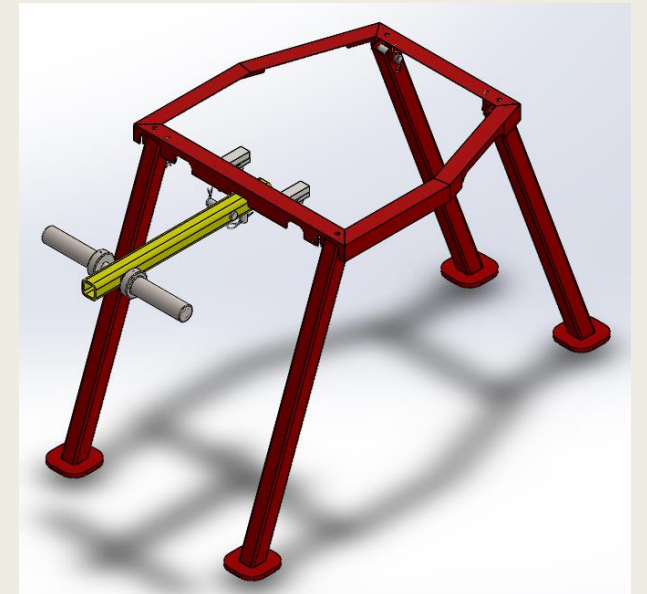
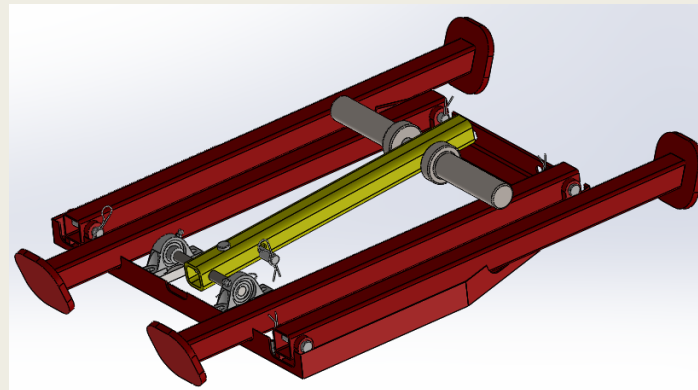
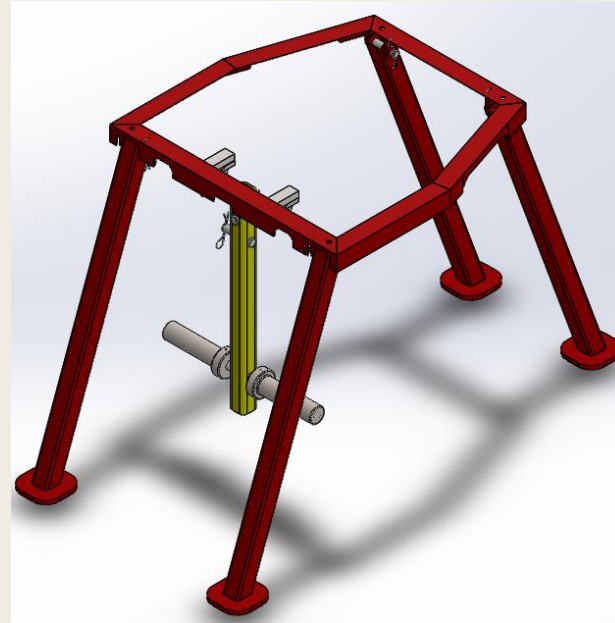
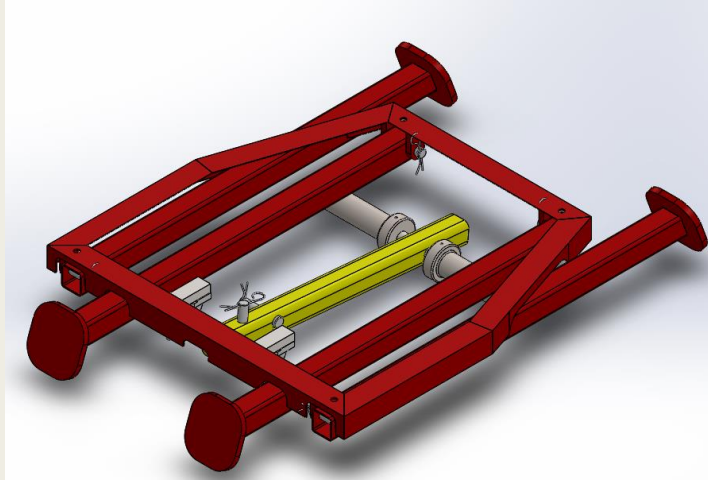



# FEAs

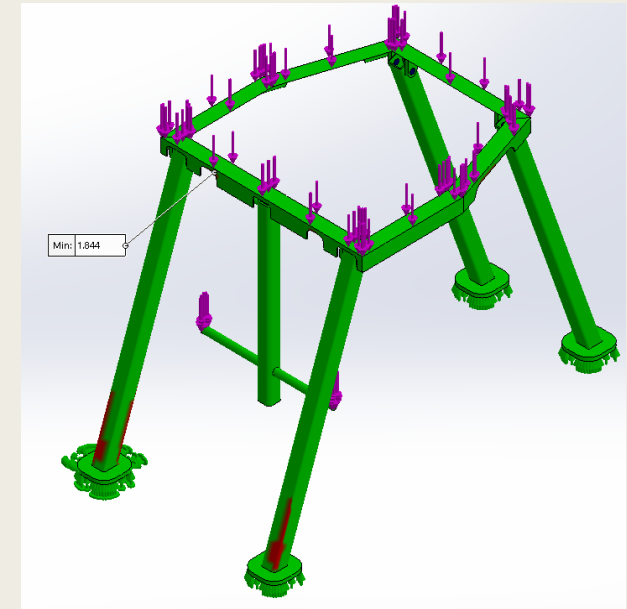
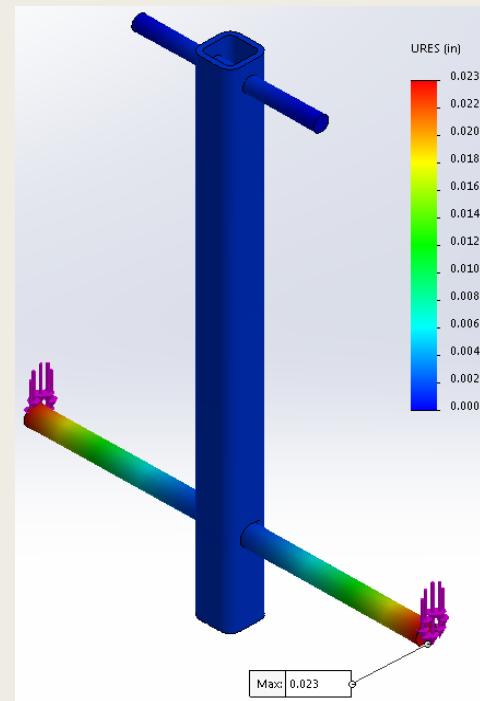
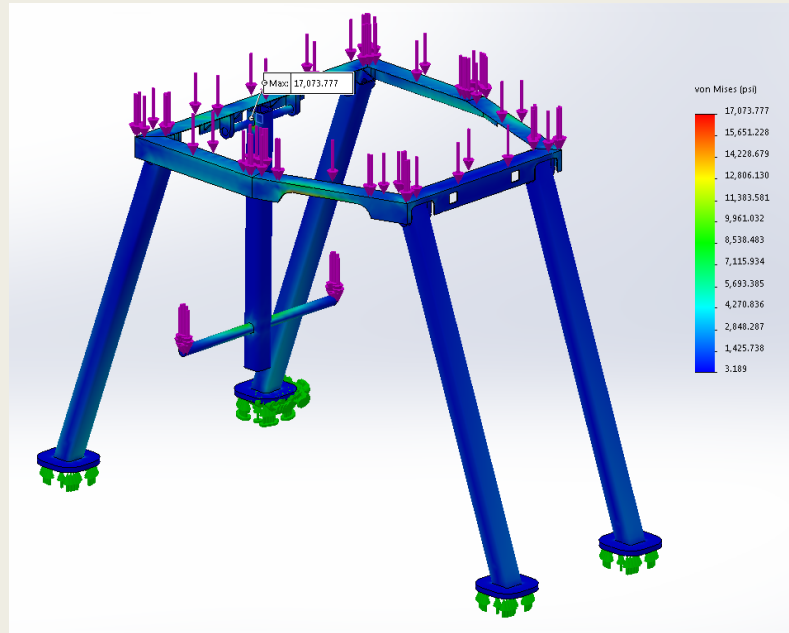

# Manufacturing Process

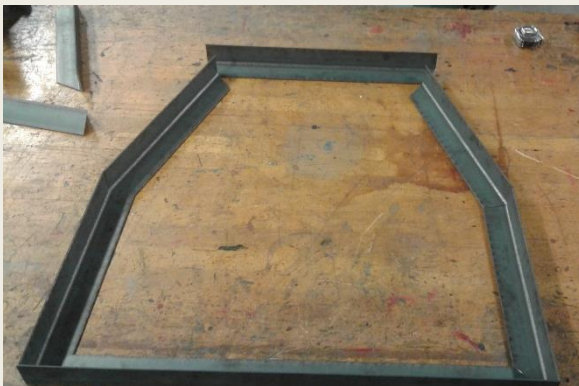
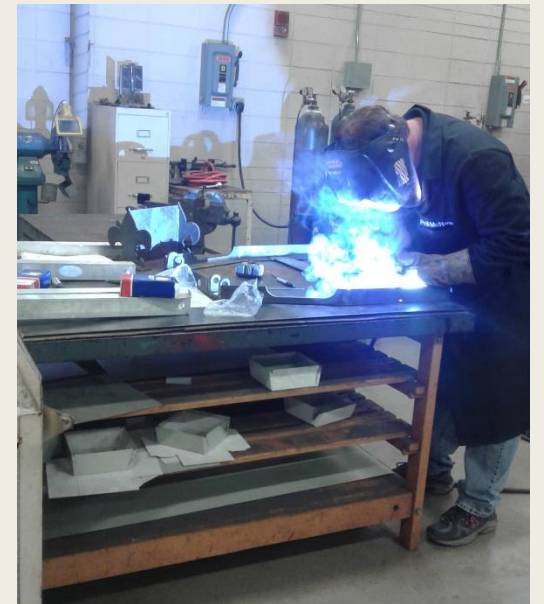

# Manufacturing Process

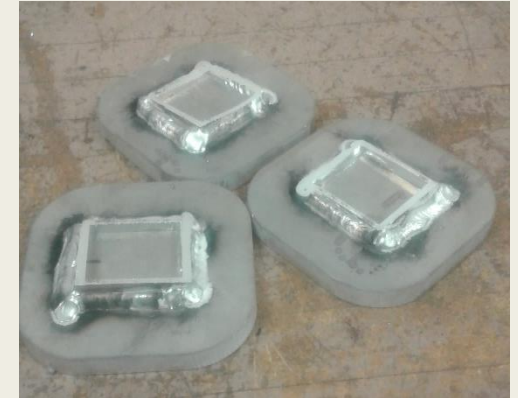



# Final Prototype

