

# 2U CUBESAT STRUCTURAL DESIGN AND INTEGRATION

---

A Thesis

Presented to

the Faculty of the College of Science

Morehead State University

---

In Partial Fulfillment

of the Requirements for the Degree

Master of Science

---

by

Yevgeniy Byeloborodov

April 18, 2017

ProQuest Number: 10233181

All rights reserved

INFORMATION TO ALL USERS

The quality of this reproduction is dependent upon the quality of the copy submitted.

In the unlikely event that the author did not send a complete manuscript and there are missing pages, these will be noted. Also, if material had to be removed, a note will indicate the deletion.



ProQuest 10233181

Published by ProQuest LLC (2017). Copyright of the Dissertation is held by the Author.

All rights reserved.

This work is protected against unauthorized copying under Title 17, United States Code  
Microform Edition © ProQuest LLC.

ProQuest LLC.  
789 East Eisenhower Parkway  
P.O. Box 1346  
Ann Arbor, MI 48106 – 1346

Accepted by the faculty of the College of Science, Morehead State University, in partial fulfillment of the requirements for the Master of Science degree.

---

Kevin Z. Brown  
Director of Thesis

Master's Committee: \_\_\_\_\_, Chair  
Dr. Benjamin K. Malphrus

---

Jeff A. Kruth

---

Dr. Charles D. Conner

---

Date

## 2U CUBESAT STRUCTURAL DESIGN AND INTEGRATION

Yevgeniy Byeloborodov  
Morehead State University, 2017

Director of Thesis: \_\_\_\_\_  
Kevin Z. Brown

Every satellite built requires a structure or frame to support all subsystems and components during launch and on orbit. The structure for the CXBN-2 CubeSat satellite was designed from scratch. The CXBN-2 satellite required a novel payload which housed two CZT detectors facing opposite directions. Design requirements were controlled by CubeSat Design Specification of Cal Poly State University's CubeSat Program and NanoRacks CubeSat Deployer (NRCSD) Interface Control Document. These documents describe mechanical requirements for CubeSat developers like coordinate systems, rail dimensions, roughness, clearances, mass, center of mass, materials, anodization and separation springs. To match the extensive requirements the CXBN-2 structure went through multiple development steps like design, prototyping, manufacturing, integration, fit checks, safety verification and testing of deployment and vibration testing. In the end, a reliable 2U CubeSat structure was built and experience gained will be used for future missions.

Accepted by: \_\_\_\_\_, Chair  
Dr. Benjamin K. Malphrus

\_\_\_\_\_  
Jeffrey A. Kruth

\_\_\_\_\_  
Dr. Charles D. Conner

## TABLE OF CONTENTS

1. CHAPTER 1 .....	7
1.1. Executive summary .....	7
1.2. Introduction .....	8
1.2.1. Motivation.....	8
1.2.2. CubeSat .....	8
1.2.3. CXBN-2 .....	9
1.2.4. Proposal.....	10
2. CHAPTER 2. Previous Work. ....	11
3. CHAPTER 3. BUS DESIGN .....	14
3.1. COTS structures .....	14
3.2. Design specification .....	15
3.3. 3D printing technology for prototyping .....	16
3.4. Subsystems .....	17
3.5. Structure components.....	21
3.5.1. Side panels .....	22
3.5.2. Crossmember .....	24
3.5.3. Antenna plate .....	25
3.5.4. Solar panels.....	28
3.5.5. Deployment mechanism.....	33
3.5.6. Battery assembly .....	35
3.5.7. Payload support/structure and shielding .....	38
3.6. Thermal control system.....	44

3.7. Materials.....	46
3.8. Fasteners.....	47
4. CHAPTER 4. ....	48
4.1. Manufacturing .....	48
4.2. Integration .....	50
4.2.1. Assembly process.....	53
4.2.2. Problems and solutions .....	65
5. CHAPTER 5 .....	70
5.1. Testing and results.....	70
5.2. Conclusions and lessons learned .....	84
6. REFERENCES .....	88
7. APPENDICES .....	89

## LIST OF ACRONYMS

ACS – attitude control system

ADCS – attitude control and determination system

ADS – attitude determination system

CAD – computer aided design

CAE – computer aided engineering

C&DH – command and data handling

CG – center of gravity

EPS – electric power supply

FEA – finite element analysis

FOD – foreign object debris

FOV – field of view

ICD – interface control document

PL-A – payload A

PL-B – payload B

RBF – remove before flight

ROA – record of assembly

SC – spacecraft

SP – solar panel

SSC – Space Science Center

## 1. CHAPTER 1

### 1.1. Executive summary

Cubesat developers can choose different approaches in designing their space systems. As small satellite industry continues to grow, there is a variety of commercial off the shelf products that can be used to fulfil most missions' needs. Companies that produce t

heir own universal components offer all kinds of products like electric power systems, electric generation systems, radios, antennas, magnetorquers, reaction wheels, propulsion systems, sun or horizon sensors, star trackers, optical and RF imaging devices, deployment systems, structures, etc., for CubeSats for either LEO or deep space. Spacecraft can be built using purchased subsystems and accessories and actual designing step can be skipped.

However, at Morehead State University, Space Science Center takes its own approach. CXBN-2 is a bright example of spacecraft with every subsystem being developed and assembled in-house. Space system development in-house is possible thanks to two main reasons. First reason is presence of crucial equipment for manufacturing and extensive testing like clean room, vibration stand, thermo-vacuum chamber, EMI/EMC testing chamber, solar simulator, anechoic chamber and a big collection of lab equipment like network analyzers, oscillographs, programmable power supplies, programmable loads, SMD soldering stations and software packages. The second and more important reason is powerful workforce as students that have unlimited desire to learn and experience building a space system.

CXBN-2 is a 2U CubeSat which carries novel payload of two CZT detectors facing opposite directions to observe Cosmic X-Ray Background. This mission sets a list of requirements that corresponds to necessity to develop custom subsystem.



To solve this issue, newly designed structure is proposed. Using some experience gained in previous work, it is possible to create more reliable and more cost-effective supporting structure that meets all the CubeSat specifications and copes with launch stresses. After sophisticated research, design, analysis and testing, simple to assemble structure for universal application and with spare internal space was created.

## **1.2. Introduction**

### ***1.2.1. Motivation***

A lot of significant research has been done in testing and revealing the capabilities of X-ray medical imaging device. This detector was taking images in different part of spectra but it proved to work in 20-50 keV energy detection regime. This meant that payload for CXBN-2 was found. Development of all the subsystems started almost at the same time. ADCS, EPS, C&DH, communication system and structure to support all had to be developed in-house under requirements established by new payload. With a set of requirements structure for CXBN-2 had to be developed from scratch which was quite challenging because all of subsystems were developed at the same time and design changes were happening very often. When working on this project there were a lot of opportunities to learn about specifics of designing, manufacturing and assembly of systems for space applications, extensive team work, experiencing and learning about spacecraft as a system.

### ***1.2.2. CubeSat***

Year 1999 was a start point for CubeSat standard development as a collaborative effort of Prof. Bob Twiggs at Stanford University's Space Systems Development Laboratory (SSDL) and

Prof. Jordi Puig-Suari at California Polytechnic State University (Cal Poly), San Luis Obispo. The intention of creating this standard was to provide a standard for design of picosatellites to reduce cost and development time, increase accessibility to space, and sustain frequent launches. It is a great platform for educational institutions to learn every aspect of space missions. A CubeSat as a U-class spacecraft is a 100x100x100mm cube with a mass up to 1.33kg per unit.

Since this standard was introduced to space community it has started changing space industry for small satellites. In the beginning, it was considered as “toy” and later on with developing technology and miniaturization of electronics it became more popular as a serious tool for space exploration that could compete with bigger satellites.

CubeSats let you develop systems for space application that are faster and cheaper to design and fabricate that is crucial for space mission engineering.

### ***1.2.3. CXBN-2***

CXBN-2 (Cosmic X-Ray Background Nanosatellite-2) is a 2-U CubeSat mission that was led and operated by staff and students of the Space Science Center at Morehead State University, Morehead, KY. It is a follow-on of the CXBN mission that was launched on September 13, 2012 as a secondary payload on the NASA ELaNa VI OUTSat mission. CXBN-2 will improve the precision of the scientific measurement and improves the reliability of the spacecraft bus.

Scientific purpose is measurements of the Cosmic X-Ray Background in the 30-50 keV range top with a precision of <5%, thereby constraining models that attempt to explain the relative contribution of proposed sources lending insight into the underlying physics of the early universe. The goal is to collect one million seconds of data in one year of operation.

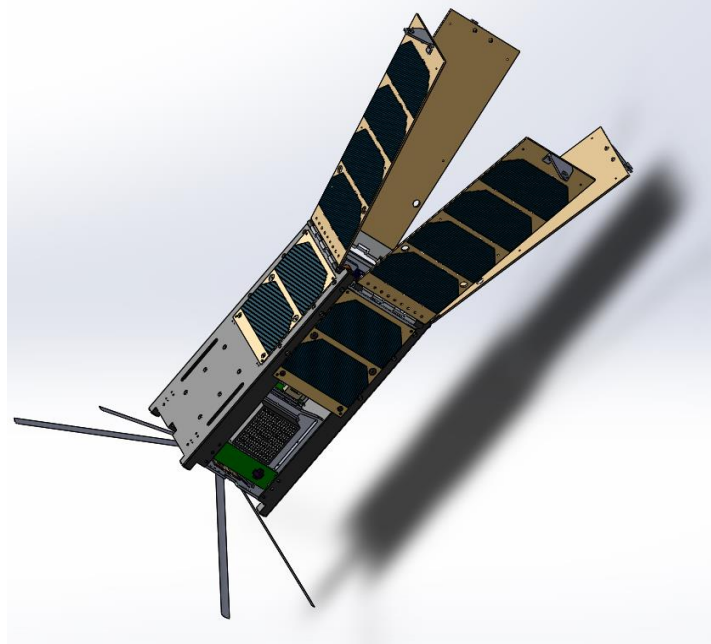

Figure 1.2.3 CXBN-2 CAD model

CXBN-2 in comparison with CXBN is a completely new system that has every components and subsystem redesigned and improved for higher reliability and better performance. It is going to be launched on April 18, 2017 from Cape Canaveral, Florida as part of OA-7 mission atop ULA's Atlas V rocket. Then it is being deployed from International Space Station in June 2017. As soon as satellite deploys mission operations begin.

#### ***1.2.4. Proposal***

In this thesis, 2U CubeSat structure and its integration is proposed. By using CAD modelling and CAE tools for analysis, cost effective and high reliability frame for CXBN-2 is designed. Systems engineering skills are applied to create structure that fits all mission requirements and makes integration simpler. Mission-specific design and integration processes are described in details.

## 2. CHAPTER 2. Previous Work.

Before CXBN-2 there were several other spacecrafts that were built at Space Science Center, Morehead State University. Two of the most outstanding missions are described below.

CXBN is a nanosatellite mission with the objective to make precise measurements of the cosmic X-ray background in the 30-50 keV range. The mission addresses a fundamental science question central to our understanding of the structure, origin, and evolution of the universe by potentially lending insight into the high energy background radiation.

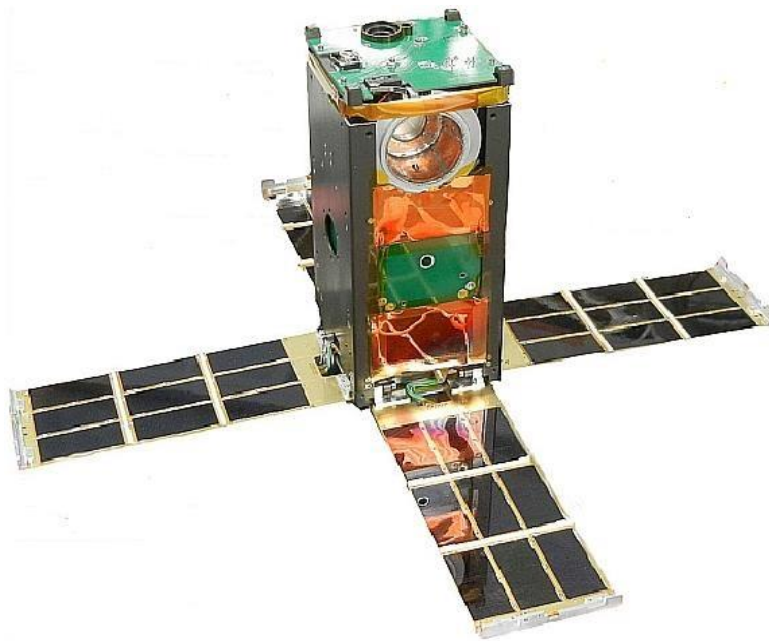

Figure 2-1: CXBN (Cosmic X-ray Background Nanosatellite)

CXBN was accepted by NASA's ELaNa program, devoted to observe improved measurements of the extragalactic DXRB (Diffuse X-Ray Background), with a new gamma ray detector system based on a CZT (Cadmium Zinc Telluride) array.

Morehead State University was responsible for the engineering of all spacecraft subsystems, and the detector was being designed by UCB, LLNL (Lawrence Livermore National

Laboratory), and Noqsi Aerospace. CXBN features many unique systems, including sun sensors, a star sensor system, an ARM-7 Coretex processor, and an articulating solar array.

Structure on this spacecraft was also made of hard anodized aluminum 6061-T6. It serves as a chassis to accommodate a monofilament cutter system that retains four deployable solar panels and blade antennas in the stow configuration. The structures and cutter system also control the deployment in compliance with the NASA LSP (Launch Services Program) secondary payload deployment restrictions. This spacecraft has a well-designed structure that met mission requirements and accommodated all of the subsystems successfully. At integration stage, several issues were revealed which included problems with hinged solar panel deployment system, complicated assembly, low accessibility to subsystems test points, cutouts in frame for antennas.

KySat-2 is the CubeSat nanosatellite designed, built, and tested by students of Morehead State University and the University of Kentucky. Development of the satellite began in 2011. KySat-2 features a 5 megapixel digital camera, a temperature sensor, a 3-axis MEMS rate gyroscope, a 3-axis magnetometer, and a “stellar gyroscope” which was developed by University of Kentucky. Morehead State University designed and developed structure, electric power system, deployable solar panels for this satellite, assembled it in the clean room and provided some of the testing. Design decisions were leveraged from experience gained with CXBN mission.

KySat-2 demonstrates key technologies developed by Morehead State University and University of Kentucky students. These include a “stellar gyroscope” for attitude determination, a distributed network computing architecture, power and radio systems.

Both missions were successful. By the time they flown in space there were more than hundred CubeSats already launched. Today there are more than 1600 nanosatellites built and

around 550 are going to be launched in 2017. There are more than 200 companies that make all kind of different parts, subsystems, kits, accessories and provide different services for nanosatellites.

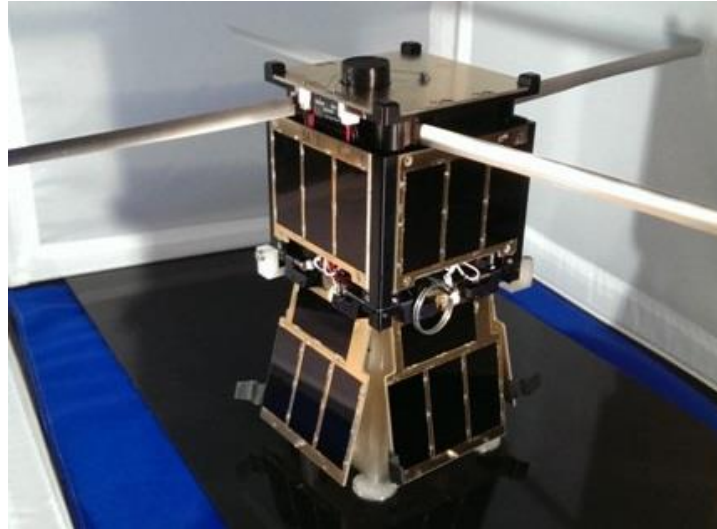

Figure 2-2: KySat-2

After reviewing previous work and looking at some of the experience of other spacecraft developers it is more feasible to design and build a whole new system that would be of higher performance, increased reliability and more cost-effective.

### **3. CHAPTER 3. BUS DESIGN**

Subsystems can not be designed independently from each other in a highly integrated miniaturized satellite platform. This section describes each subsystem after all the design iterations were completed. Here are described decisions whether COTS or custom-made components are preferred or could be used and if parts could be manufactured in-house or this service to be requested in other companies. Process of designing of spacecraft structure and its key points is described in details.

#### **3.1. COTS structures**

Before starting development of CXBN-2 structure different packages that are already built and available for purchase were considered. The CubeSat standard motivated many companies to design and build universal structures with additional features and that meet specifications.

The most popular companies that have structure kits available are Pumpkin, ISIS and Clyde Space. They have quite similar approaches, use the laser-cut parts, have additional features like embedded separation switches and RBF pin switches. For their systems prices start at \$5000 per kit.

Though these options do not satisfy requirements for CXBN-2 mission for several reasons. First reason is price. As it was planned to have 3 sets of structures, one for structural model, second for engineering model, third for flight model and additional parts for spares, minimum of \$15000 would be over mission's budget. Second reason is that design is mission specific so there would still have to be modifications made to COTS components anyway. Last but not least reason is that this development process is an irreplaceable learning experience so it serves an educational purpose.

### 3.2. Design specification

Every design starts with requirements. For structural design of CubeSat first specification that everyone have to refer to is a latest revision of CubeSat Design Specification, The CubeSat Program, Cal Poly SLO. They provide information about CubeSat standard and how to comply with it. For CubeSat Mechanical Requirements they describe coordinate systems, minimum rail dimensions, shape and surface roughness, clearances on each of the faces of SC that are limited with deployer, maximum allowed mass, position of CG, materials, anodization and separation springs. Appendices contain drawings that give more information about access ports, clearances and tolerances.

Before exact launch provider was found, CalPoly's CubeSat specification was the only relevant for the project. When NanoRacks was chosen as launch provider, main specification became their NanoRacks CubeSat Deployer (NRCSD) Interface Control Document (document NR-SRD-029). Generally, requirements are the same except for changes that included increased space allowed in X and Y axis, different clearances on +/-Z faces and need for extra separation switch and other safety features as CXBN-2 will be deployed from the International Space Station.

Alongside with Interface Control Document goes Flight Acceptance Test Requirements for environmental testing in document NR-SRD-139, CubeSat Vibration Test Record of Assembly (ROA) and CubeSat Acceptance and Integration ROA. Environmental testing and fit-check will be discussed in more details in Testing section.



### 3.3. 3D printing technology for prototyping

3D technology is a type of rapid prototyping that makes quick fabrication of a model of a physical part or assembly possible by using three-dimensional computer aided design (CAD) data. At Space Science Center 3D printer is used extensively. It is the Dimension 1200es printer by Stratasys which has sufficient capabilities to produce 3D models of 2U CubeSats.

It helps to visualize the design as a physical object. All parts can be printed, assembled and analyzed. It allows to verify if design is going in desired direction. 3D CAD models on computer screen can not always represent all the details and impurities of real manufactured parts. With printed parts, it is possible to add and easily modify components and import changes to CAD models right away. This technique is very useful especially for testing mechanical systems that need to be evaluated in their ability to perform correctly. As an example, to see if deployment system design implementations take place and theoretical calculations work on practice.



Figure 3.3 Fully 3D printed CXBN-2 model

With 3D printed assemblies, it is useful to create hybrid models by adding real parts like subsystems PCBs to check if clearance between parts allow to manage cabling and if access to

test points on subsystems is available. While waiting for machined parts it is time-saving to use plastic ones to start assembly of separate components like payload. While work is done on actual hardware, other team members can work in parallel on a separate subsystem or for example, define length of each cable, etc. So, it also saves time on manufacturing and integration.

A lot of fixtures like spacecraft assembly stands were 3D printed that saved a lot of time. Without templates for solar panel PCB modifications and templates for solar panel assembly it would not be possible to provide desired quality and accuracy of assembly. It is also a safe way to share design ideas between coworkers without even worrying about any possible damage of valuable hardware.

Another important benefit of creation of prototyped plastic models is an opportunity to easily transport and showcase or promote engineering achievements.

### **3.4. Subsystems**

Design of structure is very dependent on the subsystems that it is intended to support. In this case designing is happening from inside – out. Every subsystem has its own limitations, support requirements and heat dissipation requirements, has certain amount of mounting holes and specific shape, size, need for extra space for electrical connections and accessibility for testing purposes. Working back and forward between team members and defining optimal design for each part is what makes this spacecraft design robust and convenient for mission's needs. As the system is so compact it was crucial to accommodate allowed space inside the SC as efficient as possible.

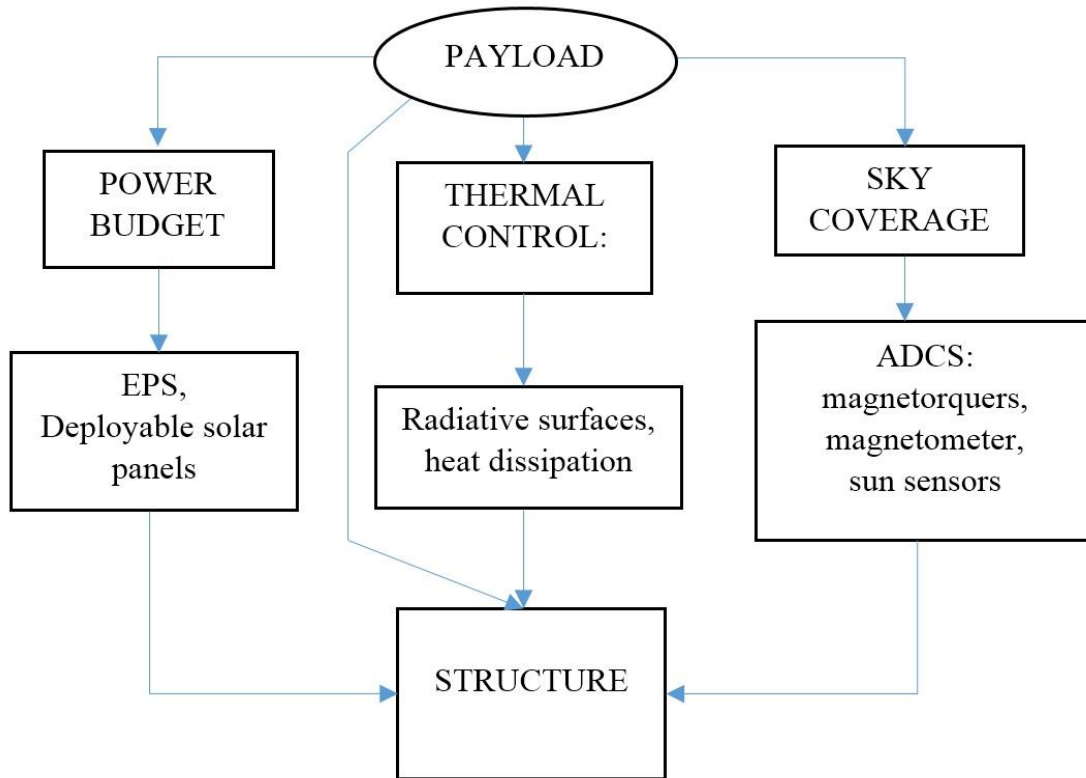

Figure 3.4-1: Dependence of structure design on other subsystems

Before all, payload was a defining subsystem that ruled design of a whole system. Payload design team made a significant research and comparison of X-ray devices and REDLEN Technologies M1770 Gamma imaging module was found to be the most desirable. Though originally intended for room temperature medical physics and security imaging applications and detection of  $> 40$  keV X/Gamma rays, it possessed the potential energy resolution and efficiency at the upper energy of interest that was most desirable for the mission while also giving the most promise to function at the lower energy portion of interest. To define if device would perform as wanted in the 20–50 keV energy detection regime, supporting electronics had to be developed in house at Morehead State University to meet the design constraints for space flight. To make this device operational and considering size limitations, power regulation, logic conversion and high voltage power supply were designed to support the M1770 module for space application in small

form factor in less than 40 mm<sup>2</sup> in cross section. Then this assembly is inserted into another part that provides collimation and shielding of the detector system.

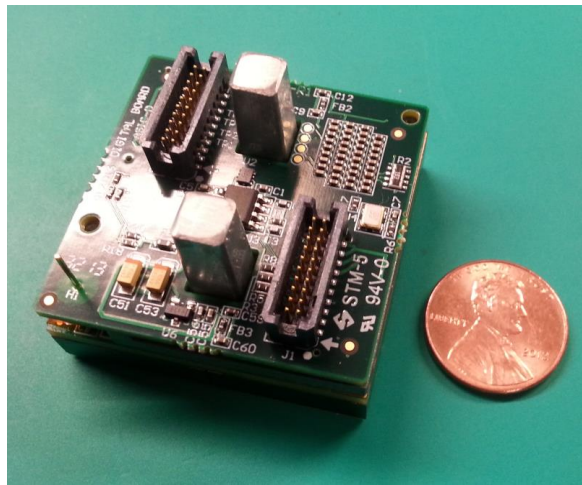

Figure 3.4-2 REDLEN M1770 Gamma Imaging Module

There are two detectors faced in opposite directions that allows to reduce time to get to mission success. Estimation of sky coverage was made by our colleagues from Keldysh Institute of Applied Mathematics in Moscow. In, approximately, one year of operation there will have been collected no less than 3 million seconds of good data, reaching a broadband S/N ~250. As a conclusion of their study, best way to control attitude of CXBN-2 is to ensure free flying. These results were driving requirements for ADCS design.

Two back to back detectors with extra shielding in between needed to be mounted inside the SC body, have brackets that attach it to the main frame. Also, there was a requirement to have two openings or windows that would provide sufficient field of view. Payload support went through 3 major design changes that is described in further section.

Position of payload was decided – it has a location in the bottom half of the SC body with detectors looking in opposite directions through structure openings. Then EPS and ACS subsystems were placed in the top half of the SC.

C&DH was first placed between collimators inside middle shield which would provide extra radiation protection for flight computer and SD card. But after purchasing radiation tolerant SD card and considering complicated assembly, C&DH was placed on the outside of payload assembly. C&DH has a square pattern for mounting holes with distance of 41mm between their centers, and 2.2mm diameter which is a clearance hole for M2 screw. Clearance between bottom of the PCB and closest surface should be 5mm for SD card slot. Mounting was achieved by using M2 screws and round spacers.

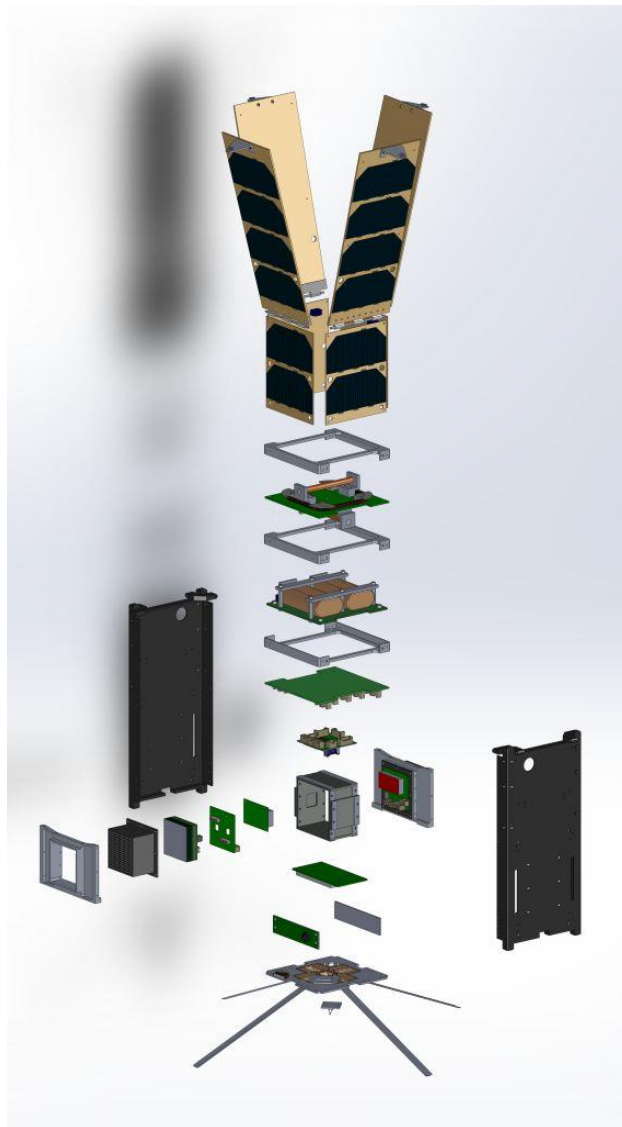

Figure 3.4-3 Exploded view of CXBN-2

All subsystems were arranged in such order from +Z face to -Z face: ACS with air-cored magnetorquer on top, battery assembly, EPS, C&DH, payload assembly, radio, ADS, antenna plate. Body-mounted 2-cell solar panels are placed on each of four sides of the top part of body and do not block the FOV of detectors. Deployable solar panels are hinged at +Z face.

Knowing all the components that are placed inside the structure between side panels, they needed to be supported. Crossmembers, payload support, antenna plate had to be designed and placed in the most favorable position. It was important to take into account that space has to be used as efficient as possible, remember that wires and electrical connections consume a lot of space, avoid interference and consider any possible changes that may occur. Description of supporting cross members and other supports can be seen in sections below.

When design of subsystems was almost defined, mass of each component could be estimated and imported into the CAD model of the spacecraft. This allowed to have better understanding of where CG is located. Subsystems could be moved along Z axis to achieve optimal position of CG. And when subsystems design was finalized the same method was used to define location of screw holes on side panels.

### **3.5. Structure components**

One of the main ideas of this structure design is to decrease number of parts and simplify manufacturing and assembly process. Lesser parts reduce points of failure, issues with tolerances, number of fasteners and reduce machining cost. Considering this idea and looking back at design decisions of CXBN mission, it was decided to choose a following approach of structure design for CXBN-2.

Structure consists of two main side panels, three crossmembers in between, two payload brackets, antenna plate, solar panels and deployment system. Extras are standoffs, spacers, pins, hinges, thread, monofilament, adhesives and fasteners that join everything together.

Next subsections describe designing process for each of the structural components. Drawings for all structural components are present in Appendix A.

### **3.5.1.     *Side panels***

Side panels play one of the most important roles in structure of the CXBN-2. They have a shape of a shell that gives the structure good stiffness, stability and shear force resistance. In this setup, all crossmembers, payload mounts, antenna plate, solar panels, deployment switches are attached directly to side panels. They have rails integrated into their design, which are only surfaces that limit movement of the SC in the canisterized deployer during launch.

First designs of side panels were very different than what there is now. In the beginning, a top cap was considered just as CXBN had. It is a block that has end part of rails with 4 feet and solar panels are attached to it via hinges. This design was not approved. Approach that was taken afterwards was defining and hasn't been changed. It was decided that side panels will have a shape of a thin-walled shell, with full length inseparable rails. Later parts of solar panel hinges were added to it. Design of this hinges was limited by CubeSat design specifications. Maximum extrusion of any part of SC from rail surface is 6.5mm in X and Y axis, that includes solar panel assemblies with hinges and fasteners, and the same limitation on +/-Z faces. So design of this hinge part is very compact, even though it includes SP deployment limiters and hinge pin capturing set screws. Hinging system is described in more details in solar panel section.

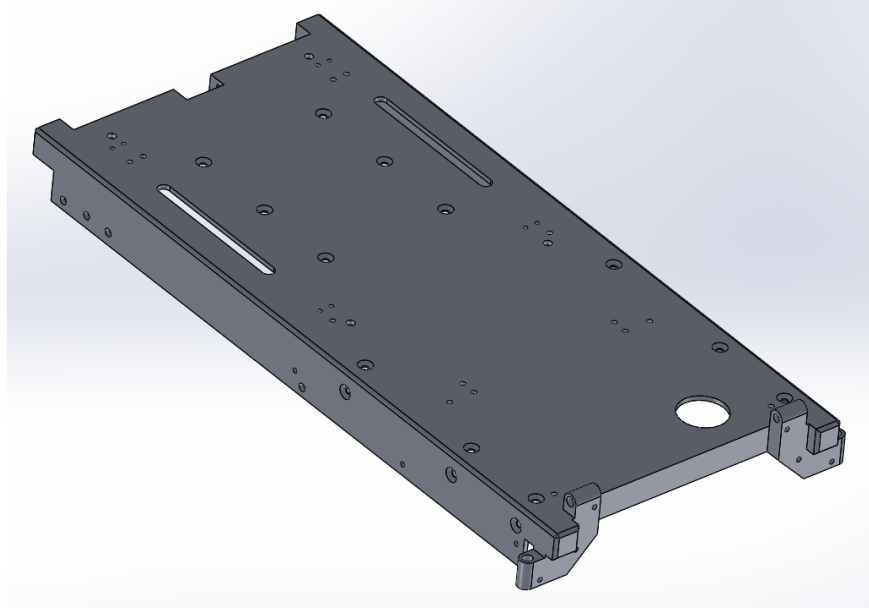

Figure 3.5.1: Final design of side panel

On every side of side panel M2 counter sink holes for crossmembers are placed. They must be flush and position of these screws is moved on the rails to avoid interference with body-mounted solar panels. The same screw holes are used for payload brackets on +/- Y faces and antenna plate on -Z face. M1.6 threaded holes on +/-Y faces are for custom radiator hinges. There are M2 threaded holes for body-mounted solar panels, SP deployment limiting screws, servicing holes to securely mount spacecraft while testing, deployment switches, RBF pin switch and a hole for RBF pin. Solar panels have to have a restrictors form side to side movement when stowed and also spacers that keep distance between deployable SP and SC body constant. This was achieved by repurposing M3 set screws and using tapered cone surfaces for positioning. Threaded holes for set screws that align SP were added respectively. ADS M3 threaded mounting holes are located on +/-X faces just under collimators. There had to be found a way to limit movement of hinge pin and it was achieved by partially threading hinge sections for M3 set screws. It allows adjustment of clearance by screwing and unscrewing these set screws. Thermal regulation system needed a way to transfer extra heat from payload to deployable radiators which



was achieved by placing slots for heat paths from payload to external +/-Y faces. Additional are cutouts for SP connector, for antenna bend, and holes in feet for deployment switch pins.

In the end, there are main structural parts as side panels that have universal design and this or similar design could be used for other missions that use 2U CubeSat form factor.

### **3.5.2. Crossmember**

CXBN-2's crossmember is a very important intermediate component that has to connect subsystems and transfers loads to the main frame – side panels. It has to provide structural integrity and stability, connects two side panels and supports subsystems.

First designs of SC structure had four crossmembers. One for Z+ face where solar panel hinges are located, second for ACS, third for EPS and battery assembly and fourth for Z- face as antenna plate support. Forth crossmember was eliminated as its purpose was replaced after payload support and antenna plate were more defined. Having another square bracket at Z- face was excessive.

Amount of material that is used in in crossmember allow heat flow between side panels and subsystems. Results of thermal analysis can be seen in simulation chapter.

Top of a crossmember is a flat surface so that subsystems can have high contact area. This helps eliminate high amplitude vibrations and flexing of subsystem's PCBs. In the middle of a square bracket is a cutout for fitment of all extruded soldered components. Two opposing sides have cutouts that let cables and wires to pass along the SC. These passages capture cables between a side panel and crossmember and don't let any abnormal freedom of movement that could damage themselves or other subsystems, solar cells during launch vibrations.

If looking at a part from the bottom it has thin-walled extrusions that add stiffness in open areas that are not enclosed by the side panels. These extrusions have M2 threaded holes for attaching crossmembers to side panels with M2 flathead screws. For a crossmember that is at Z+ face it was required to make extra holes for avoiding interference with body-mounted solar panels' fasteners.

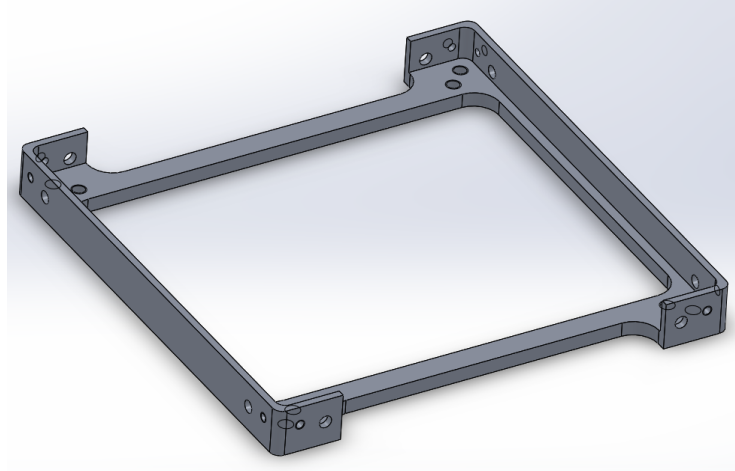

Figure 3.5.2: Crossmember

Hole pattern that is on top of the square bracket was established as a standard together with other subsystems developers. Main four holes for EPS and ACS are M3, threaded. Spacing between them is 87mm. Other four threaded M3 holes are for battery rack only and with 80mm distance between them.

This design makes it possible to use the same part multiple times in the structure of SC

### 3.5.3. *Antenna plate*

Area on the -Z face was reserved for antennas. Quadrature antenna array had to be securely mounted on the supporting structure. It had to be space efficient, have low mass, be simple and robust to provide dependable antenna fixturing and deployment. Design of an antenna plate shall

allow mounting of several systems on it. First designs considered mounting radio with standoffs on the bottom of the plate. But after some design iterations with payload mounts it was decided to move radio onto payload-C&DH subassembly.

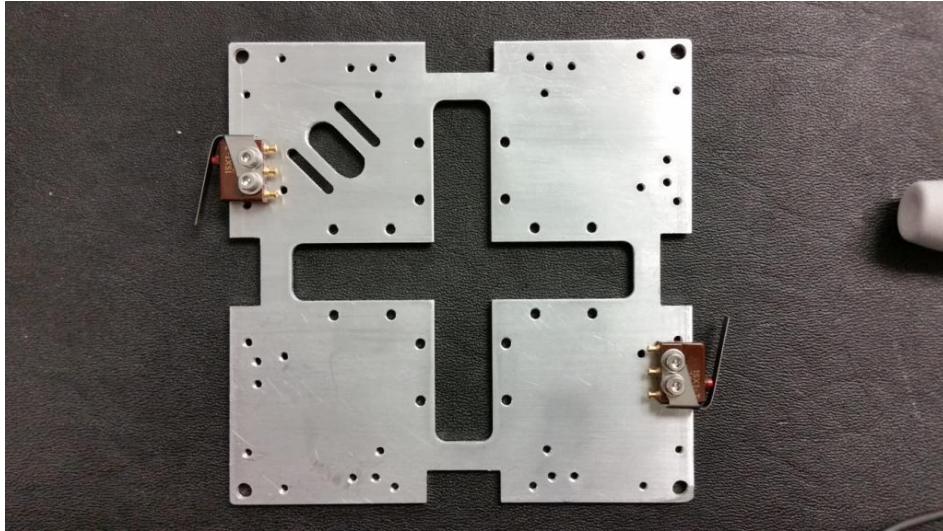

Figure 3.5.3-1: Manufactured antenna plate with switches

Slots are added for cutter so it allows to be adjusted for the correct monofilament passing and tension. Cutter is secured with screws, washers and special nuts on the bottom. Nuts were modified so they slide into slots and do not spin freely while tightening screws after adjustment of cutter position is complete.

When antenna is folded, it bends and creates a specific curve with minimal radius. If antenna blade is bent any further, then plastic deformation occurs and when deployed afterwards it's not straight anymore. This should be avoided at any cost for the communication system performance. That minimum radius was measured and implemented in antenna plate design as cutouts on each of the sides with sufficient margin.

Switches are placed on the bottom of a plate. They are used for sensing solar panel deployment and when solar panels are deployed it turns the cutter off. Honeywell 1SX1-T micro

switches and JX-40 lever attachments are used. When SP are in stowed position lever pushes on the surface of L-bracket and electrical circuit is closed.

Originally plate had round holes in each corner for SC deployment switch pins. During integration, it was changed to cutouts as assembly process was too complicated and inconvenient as plate was interfering with pins.

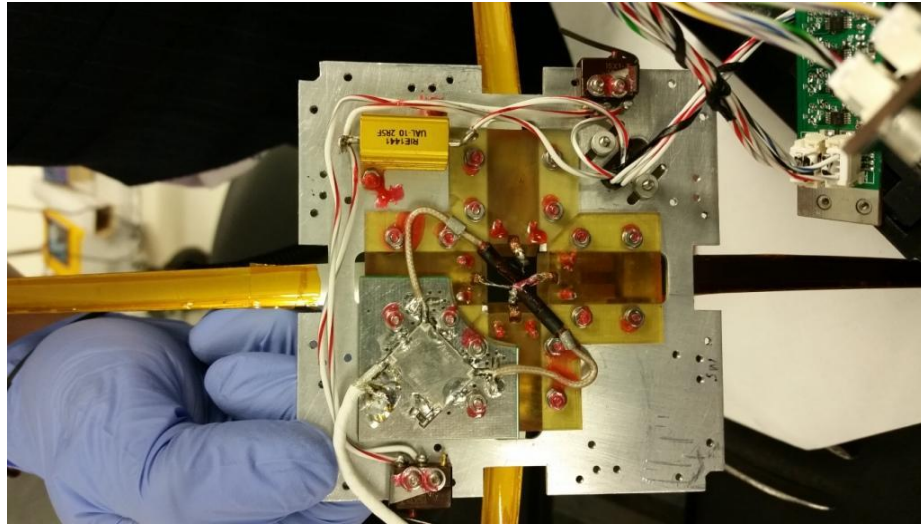

Figure 3.5.3-2:Antenna plate layout

After all parts are mounted on the plate, it is covered with copper tape on the bottom for RF shielding purposes. For better grounding, tape is also being screwed down with screws. Then it is secured and insulated with Kapton tape.

For cost reduction and simplification of manufacturing standard 1/16" aluminum sheet was chosen. Plate has M2 threaded holes along the edges that attaches it to the rest of a structure with M2 screws. Position of all mounting holes is symmetrical and doubled so that components could be rearranged in many ways in case any assembly issues may happen. This part is made in-house because of its simple design that is easy to machine and hand finish.

In final design antenna plate accommodates antennas with antenna mounts, switches that monitor SP deployment, monofilament cutter and resistor, antenna phase matching circuit for communication system and copper tape shielding that goes over RF parts.

#### 3.5.4. *Solar panels*

Design of solar array depends on desired power generation. Number of solar cells that can be placed on the spacecraft is limited and depends on their shape and size. There were different options considered for solar cells that include:

- Solar cells used for CXBN
- Other cells that were in stock
- Find and purchase new ones

Third option was the most relevant and best solar cells that were available are AzurSpace 3G30A. they are 28-30% Triple Junction GaAs Solar Cell. This cell type is an InGaP/GaAs/Ge on Ge substrate triple junction solar cell assembly (efficiency class 30%). The solar cell assembly has an improved grid-design and is equipped with an integral bypass diode, interconnectors and cover glass. They have higher fill-factor and solar cell efficiency than their competitors.

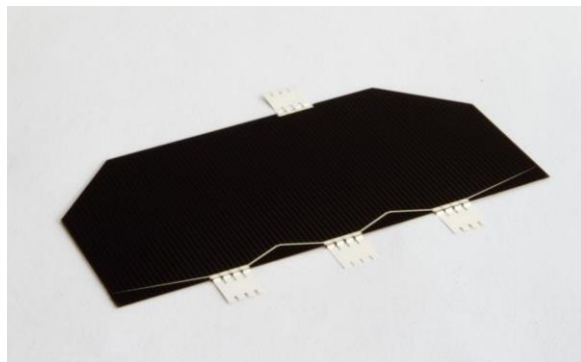

Figure 3.5.4-1: Azur Space 30% Triple Junction GaAs Solar Cell

But even those were not enough if placed two on each side of the body of SC. Body mounted solar panels would not provide enough power generation so deployable solar panels became the only option.

There had to be more than 7W of power generated to feed payloads and other subsystems. Body mounted solar panels could only fit two cells per side, 8 in total. Then single deployable solar array was proposed. With CZT detectors consuming around 1.5W each plus the rest of the subsystems there was still negative power margin considering only one side is illuminated at a time which is 6 cells. Extra cells had to be added to meet power budget requirements. Only 4 solar cells could comfortably fit one deployable panel and space for body mounted solar cells was limited to two per side. It became a real challenge and it was decided to meet this requirement with double-deployable solar array. Each deployable solar panel could fit 4 solar cells when they are fitted very close to each other and letting some margin for attachment of hinges. This configuration resulted in 10 cells per side, as 40 total. This solar array could generate 10.6W per side (10 cells) and gave 33% power margin which was great. Deployable solar panel (panel #2) that is closer to body has hinge on each side. Deployable panel that opens first (panel #1) has brackets that were retained by the deployment monofilament while on the other side it had hinges that were attaching to second deployable and a simple but reliable deployment mechanism. This mechanism consists of a slot in the solar panel's PCB and a screw on the body of SC. A screw keeps solar array closed until the top solar panel starts deployment and at certain angle releases from the screw which respectively lets second panel start deploying. Motion of panels is actuated by torsion springs that are embedded into hinges.

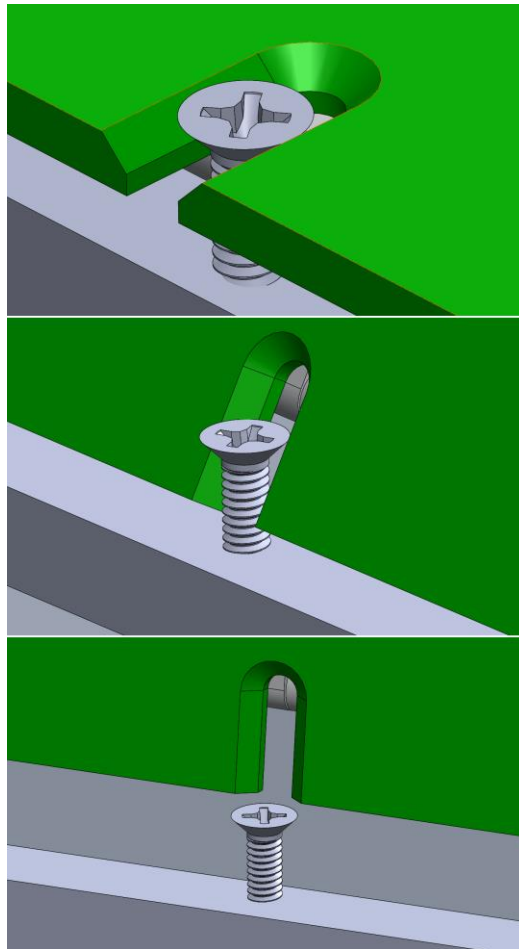

Figure 3.5.4-2: Double-foldout solar panel deployment mechanism

When payloads went through extensive testing it was found that some noisy pixels had to be turned off. That radically changed power consumption and power budget was revised. Each CZT detectors now consume 1W. That gives 5.4W system average consumption per orbit and with single-deployable panels, usable solar power input per orbit is 6.4W so power budget margin is 15%. As a result second deployable solar panel was unnecessary. This led to a complete change of the deployment system and solar array design. Monofilament restraint system had to be placed on a different side of spacecraft, on the antenna plate. Design was simplified again and became a lot more compact, reliable as number of moving parts was cut in half.

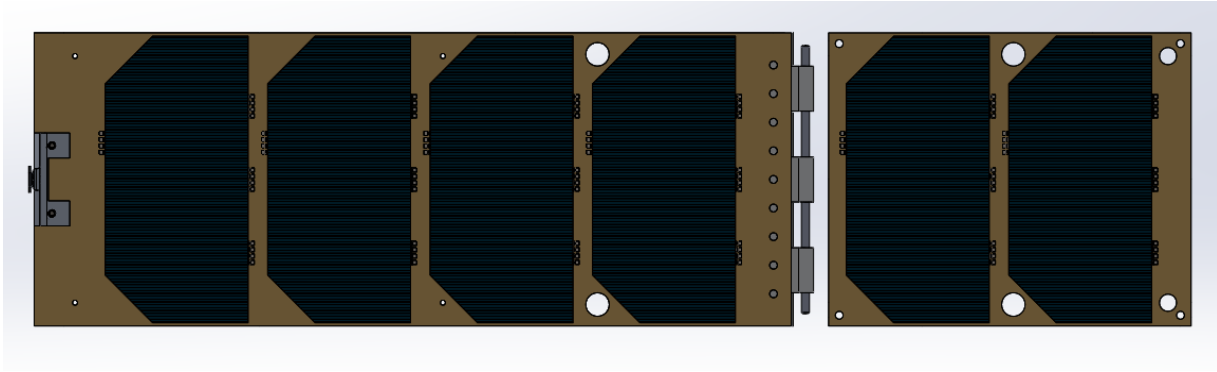

Figure 3.5.4-3: Layout of solar cells on solar panels

As solar array deploys, it is pushed by the 3HPF2 torsion springs and it had to be stopped at some point. All four panels are deploying simultaneously and when they reach point of full 180-degree deployment they may hit each other. SP opening angle limiters had to be added to avoid damage. 165-degree angle was found most optimal. Different variants were considered, like adding material on the part of a hinge that is closest to structure, making another machinable part that would get attached in the same position and similar ideas. But these options were very limiting. Considering imperfection of hinges and hinge pins, every solar panel would have different angle of deflection. So, deployment limiter have to be adjustable. And the best simplest and cheapest solution that was found is to use a flathead screw. It is M2 flat head screw that is screwed into hole on structure behind the hinge. Deflection angle is easily adjusted by turning this fastener. When solar panel deploys it hits this screw and stops at 15-degree angle.

For moving parts, it is very important to have smooth motion without any interferences. For hinge as one of the most critical component of deployment system it was important to find high quality parts that would satisfy size limitations and have high reliability. Several types of piano hinges were taken under consideration, but only one was satisfying enough. It is a military specification piano hinge MS20001-2 made of extruded aluminum. It has several benefits. It is high quality extrude hinge which means that it doesn't have a chance to unfold like other



stamped hinges. Hinge does not have mounting holes in it so they can be added wherever desired. It has a size that fits the system as required. Hinge is cut into pieces that fit panel's PCB, epoxied onto PCB and then M1.6 screws are used for keep hinge from peeling off and for joint to be extra secure. Detailed process of assembly is described in manufacturing section. Military specification hinge was supplied with aluminum pin. This would not be applicable for design as aluminum tends to cold weld in vacuum. Steel pin was chosen instead. After some polishing and fitment, it can be slid into hinge on solar panel side and on side panel side together with spacers and torsion spring. 3HPF2 torsion spring has been chosen by geometrical parameters and force output. It has 270-degree angle between legs and torque at 1/2 leg length is 0.234 In-lbs. When pin is inserted it has to be restricted from sliding out that is achieved by using M3 set screws on each side of the side panel part of hinge.

As mentioned in side panel section, solar panels have to be aligned when in stowed position to limit any side to side movement. This is achieved by using set screws on the side panels. Four holes are placed on each solar panel PCB that set screw can be aligned with its cone-shaped top. Under pressure that is provided by monofilament this connection stays stable until deployment. Two M2 clearance holes are placed on the end of panel for mounting L-bracket. The same holes are on the bottom and they are for increasing grip of epoxy with PCB. Deployable panel is made of gold plated 0.064in thick FR4 PCB, when body-mounted is 0.032in thick. Body mounted PCB has 4 holes for mounting with M2 screws to side panels and holes for places where aligning M3 set screws are located. Both PCBs have holes that allow access to RBF pin when solar array is in stowed position.

Design of solar panels fits the requirements in power output and is being within size limitations. It is also a robust system where deployable panel can be easily and quickly replaced

if requested during integration. It was very useful to take an approach of using as many COTS parts as possible with minimal modifications as it helped to reduce cost and make parts easily replaceable.

### 3.5.5. *Deployment mechanism*

Deployment mechanism consist of L-brackets on solar panels, switches, monofilament as main restraining element and monofilament heated cutter.

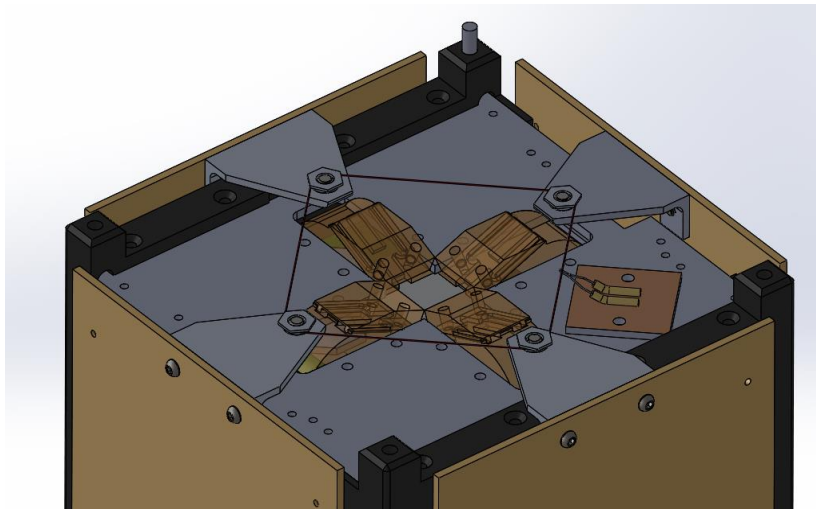

Figure 3.5.5-1: Deployment mechanism

There is a countersunk hole placed on the top of the L-bracket's flange. It is used for a flat head 6-32 screw and a PEM F-632-1 self-clinching 6-32 nut. This self-clinching nut is repurposed to serve as a hook for monofilament. It has a smooth sliding surface and does not let monofilament to get unhooked during launch vibrations. Combination like this is simple, saves a lot of space and securely restrains the system. To mount this L-brackets to solar panels there are two mounting threaded M2 holes made on the other flange. It is designed to serve 2 purposes: restrain solar panels and antennas from deployment. When solar panel is stowed, and antennas is

captured between SP and body of the SC, L-bracket pushes on top of bent antenna. This doesn't let antenna get unfolded until solar panels are deployed.

Monofilament that restrain solar array is a Spectra thread that is rated to 20lbs. For previous missions like CXBN it was common to use nylon line. It is able to degrade in vacuum and under UV light which is a level of redundancy if Nichrome cutter fails. Negative side of nylon is that it stretches a lot under stress and in spacecraft case – under launch vibrations. After short research the solution was found. Spectra threads is a very strong monofilament that almost does not stretch. It is very flexible, easy to cut with heated cutter and has very smooth surface that lets it slide through hooks and not get caught.

Heated cutter is a repurposed cauterizing tip from Bovie. Cutting element is a high resistance heating wire made of Kanthal A-1 alloy. Wire is crimped in two brass tubes. For monofilament cutter purpose, excess tubes were cut and rest of it was bent the at 45-degree angle. After that it is soldered onto PCB with mounting holes and power cables and then mounted on the antenna plate.

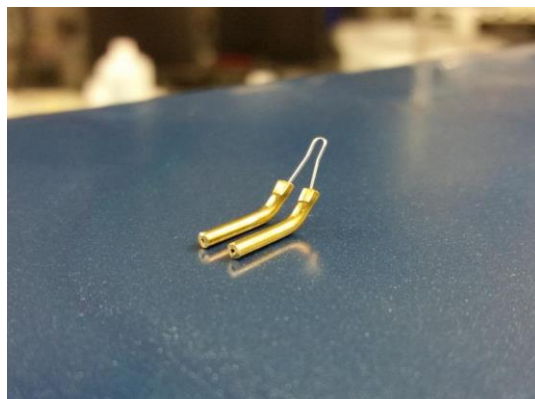

Figure 3.5.5-2: Monofilament cutter

There are six switches in CXBN-2. One for RBF pin, three separation switches that cut power to EPS and two solar array deployment switches that turnoff cutter circuit. All switches are Honeywell 1SX1-T micro switches and all except for RBF pin switch have JX-40 lever

attachment. It is a miniature switch that can handle high electrical loads and has very reliable actuation system with steel lever. All switches have two mounting holes and are attached to side panels and antenna plate with shortened M2 screws and washers. Three separation switches are actuated by push pins that are installed in respectively three holes in feet of -Z face. When pin is actuated, it pushes on switch lever and then switch and opens an electrical circuit.



Figure 3.5.5-3: RBF pin and switch

This design of deployment system showed its reliability and ease of operation. During all of the tests that were conducted for spacecraft, deployment system has 0% failure.

### **3.5.6. Battery assembly**

Powering spacecraft in shaded parts of orbit can be achieved by using sufficient amount of energy storage units, batteries. They have to be safely installed in the satellite body, placed next to power management and generation systems to reduce wire resistance losses and CG location has to be within specified limits.

First design of battery mounts was just the same as CXBN had. Four 18650 type batteries placed in clamps and mounted on a crossmember with 2S2P connections method. This would

have not required any extra manufacturing or designing as parts were available from previous mission.

Part of a team that was responsible for EPS found better solution for a battery. This battery is Swing 5300. It was chosen because it had longer lifespan as maximum number of charge-discharge cycles is significantly higher (>3000 cycles) than competitors. It has the same voltage and higher capacity, also has different form factor just like two 18650 batteries were put together in parallel. These Swing 5300 batteries were connected in series.

What became challenging in mounting of Swing 5300 is that main outside casing is positive. While the rest of subsystems use structure as negative pole (GND), only way was to design battery mounts that isolate it from the rest of the structure.

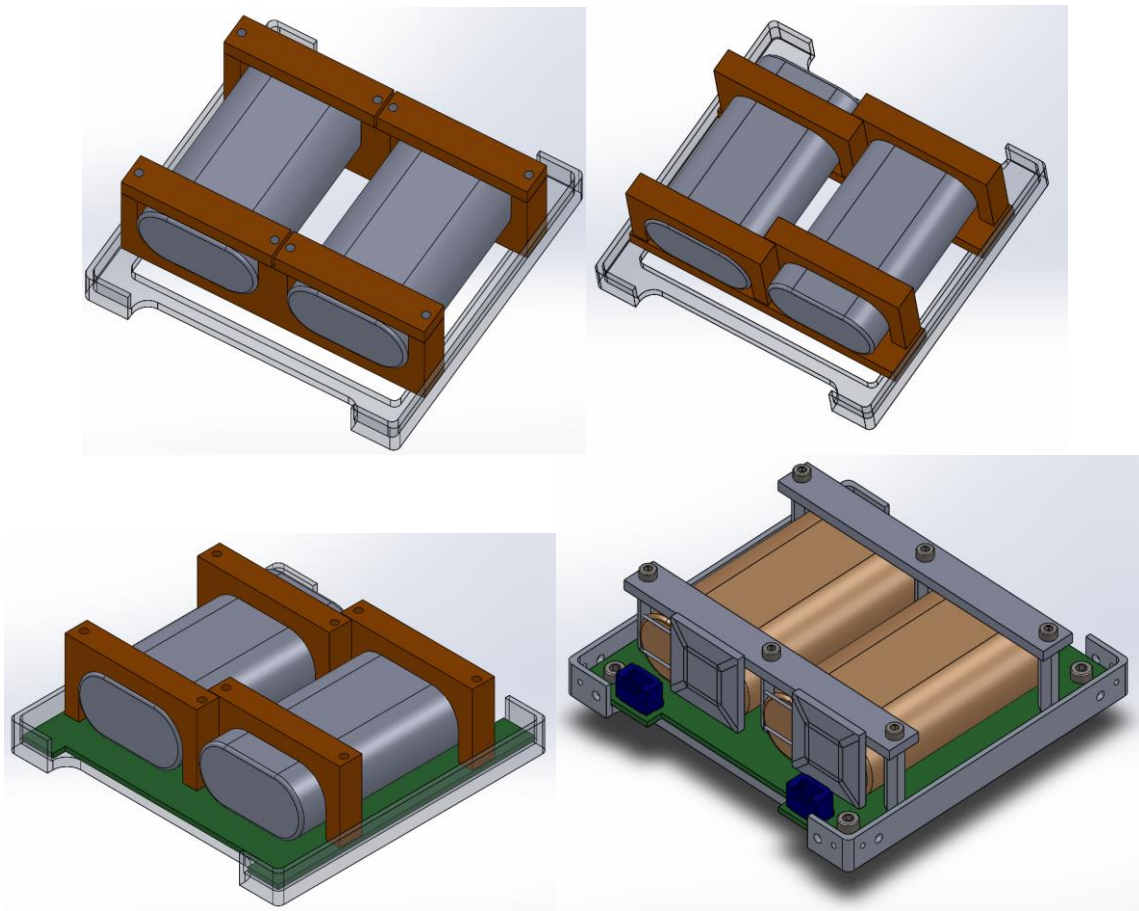

Figure 3.5.6-1 Battery assembly design progression

New design started with isolative blocks that were clamping batteries and then all together attached to crossmember. There were several designs as you can see on a picture below. All of them required machining and had to be made of dielectric material. This could be satisfactory but didn't meet philosophy of simplicity at all.

As EPS system was developing, there was a need to place a resettable fuse for battery circuit safety so a separate PCB had to be added. And this was a point when important decision was made. Primary support for the batteries became FR4 PCB. This material was a great solution. It is relatively lightweight, easily available, modifiable, non-conductive and has good mechanical properties as it is a glass fiber composite.

Adding all parts together was PCB one side and on the other 2 aluminum blocks that were fastened with M2.5 screws and standoffs. Batteries had to be wrapped in Kapton tape and placed in such position so that fastener for standoffs didn't have a chance to get grounded. This was easily achieved as crossmember was being designed at the same time.

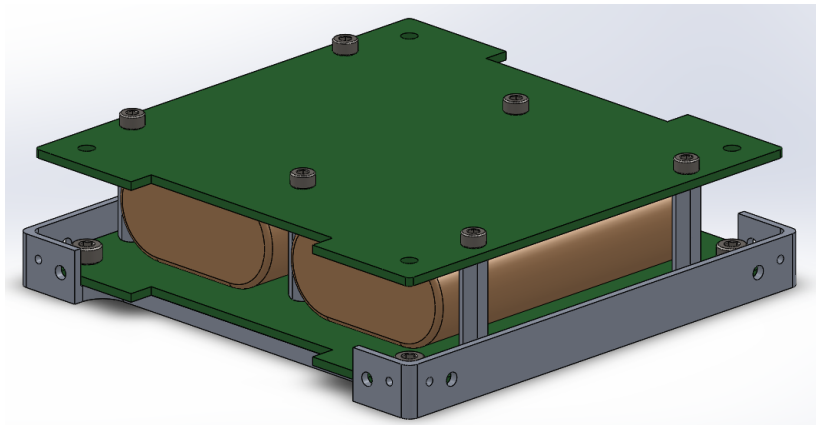

Figure 3.5.6-2 Final battery assembly design

During assembly and integration process it was noticed that two top blocks of aluminum weight as much as one PCB. PCB was fitted on top of the batteries and this change was kept.

This had several benefits. Two separate machined parts were eliminated, it saved some space inside the SC, reduced pressure on the surface of batteries and simplified integration process

In the end two batteries are covered in double-sided tape and sandwiched between 2 PCBs with standoffs and screws.

### **3.5.7. *Payload support/structure and shielding***

It was previously described how payload should be positioned and oriented in the CXBN-2. Two back to back detectors point in opposite direction through openings in frame. When it came to payload support design, a list of requirements was set for correct payload operation.

Design of collimator greatly depended on the material that could be used. Based on the mass limitations, X-ray fluorescence characteristics, and need to shield the detector to allow absolute background X-ray emission detection two high z materials were considered. Pure lead was the first choice as it has a high density of 11 g/cm<sup>3</sup> which would serve as sufficient shielding for the detection energy of interest by using a thickness of about 2mm. The problem with pure lead is that it is difficult to machine and as does, not have the rigidity needed for the vibrations levels expected during launch of the satellite when, only 2mm thick. Even if pure lead was chosen, it would require complex supporting fixturing. The other issue is that when looking at other lead alloys many of the materials used in the alloys produced fluorescence in the energy range of interest.

Another option for high density material was tungsten. Tungsten's density is 19.3 g/cm<sup>3</sup> which would provide excellent shielding per volume and unlike lead has appropriate rigidity, though because of its high density it too is extremely difficult and expensive to machine.

Given the nature of the collimator high precision was needed on the individual openings for each pixel allowing uniformity of collimation angle. The thickness of material between each pixel was a mere 0.5mm.

Taking this into account several companies were contacted to see if and for what price such a part would cost to manufacture. There were several companies willing to machine tungsten, such as Plansee Corp, though the cost was US \$4,900 per unit. For such a complex part it was even considered to create an assembly of tungsten stripes that would lay in two layers to create grid. After some research and brainstorming, 3D printing technology came to mind. This part can be printed with tungsten polymer blend and after long research H.C. Stark of Euclid Ohio was found. The production price of the collimators was quoted for US \$400 per unit. The only drawback of this was the company could not guarantee quite the tolerances desired for the design as manufacturing method with this material was experimental. Then it could have any shape requested and final design of collimator was a grid of 256 holes with shielding extrusion on the perimeter that ends with mounting flange with 8 holes.

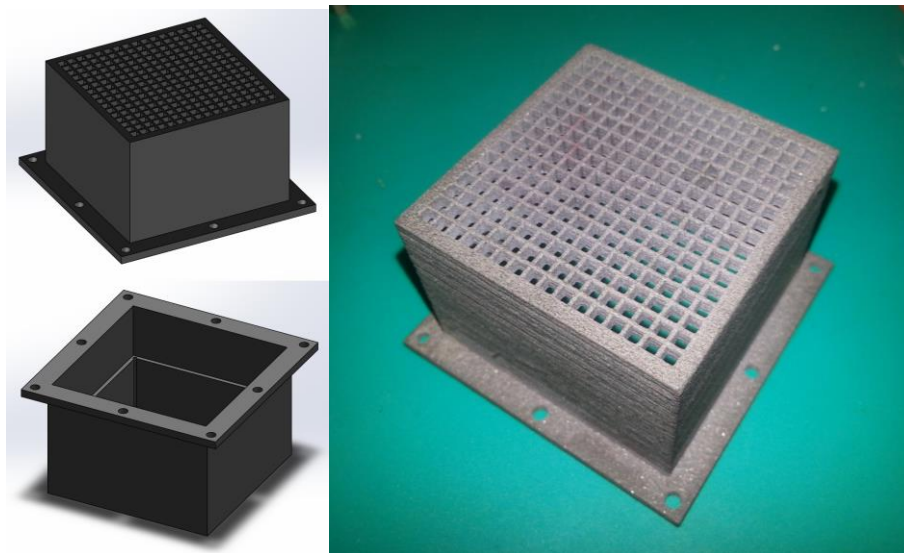

Figure 3.5.7-1: 3D CAD models and 3D printed collimator



When collimator and part of shield were designed, next step was a design of structural support of payload. Main requirements for this fixturing were structural stiffness, universality for supporting several subsystems, heat dissipation, to be safe from incident photons, compactness with minimum mass and ease of integration.

First prototypes were very complex machining vise as they were mounting between collimators and rails of the main frame and had a lot of ribbing to ensure stiffness. It was also taking a lot of space as there were two parts on top and bottom and two parts that were capturing payloads. Later design was changed to a mount that attaches payload assembly to walls of side panels. 1.5mm of wall thickness was sufficient to mount relatively heavy payload assembly to.

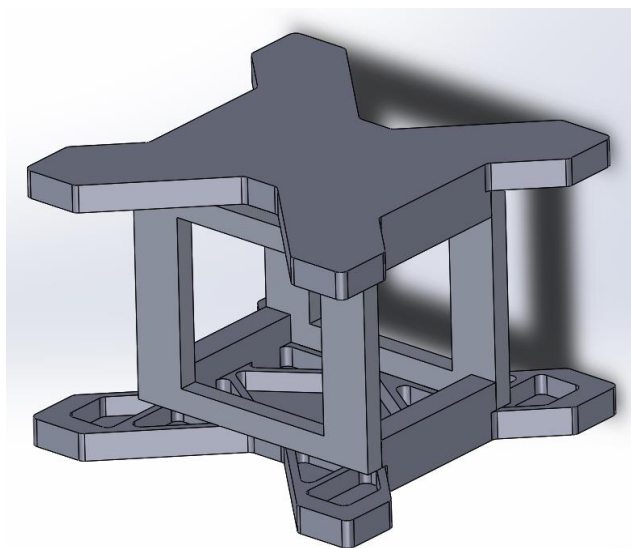

Figure 3.5.7-2: First design of payload mount

Next designs were a lot simplified and consisted of only two identical parts for support. For weight reduction, it had cutouts which were later changed to thin walls. It had a set of mounting holes for collimator, lead shields and C&DH that at that time was placed in between detectors behind shielding for extra radiation protection.

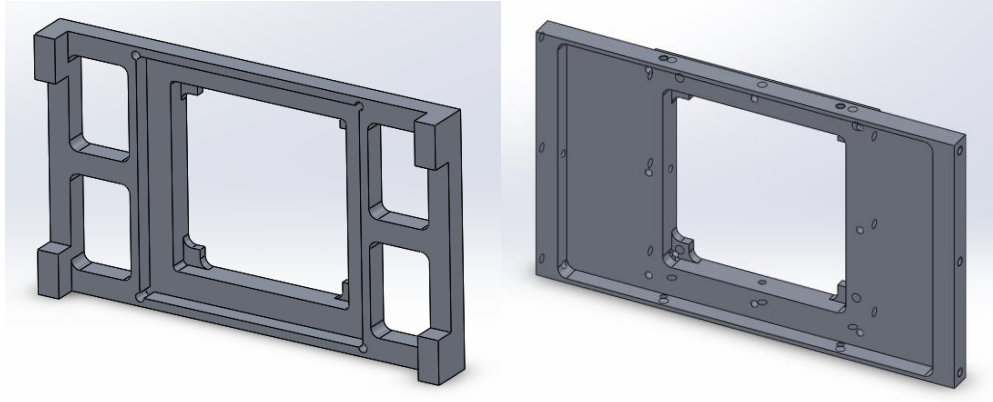

Figure 3.5.7-3: Payload mount design progression, version 5 and version 7

This design was satisfied until it was experimentally discovered that the 3D printed collimators were very fragile. During assembly, it was found that mounting holes and flanges were cracking under light torque from fasteners, even with bigger washers. Next, aluminum rings were tried that would distribute load more evenly, which also failed.

Considering this problem, redesign of payload mounts started again. An extrusion that collimator can be slid in was created. Its purpose is to support thin and fragile collimator walls. On the side where collimator goes, a flat flange is located for positioning via holes. When parts are aligned, they are epoxied together. More detailed process is described in integration section. This connection has several benefits. Collimator is completely secure from vibrational breakage, heat transfer from collimator to structure is a lot greater and further assembly process is a bit simpler.

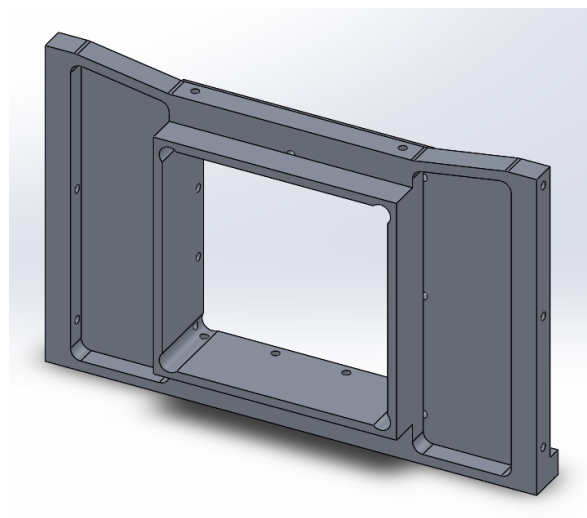

Figure 3.5.7-4: Final payload mount design, version 8

Required shielding had to be designed for the open area between detectors. Pure lead was used this time as it was a lot easier to machine and bring to desired shape. Payload mounts already had all needed threaded holes for mounting lead pieces. To ensure correct reading by detectors it was required to make sure that incident photons do not have any path to hit CZT sensor from any other angle but front, through collimator. Incident photon angles were modelled and lead shielding in conjunction with collimator parts were placed in such a way that incident photon lines did not reach back faces of CZT detectors. There are in total 6 lead pieces that go on payload assembly. Two bigger lead pieces on top and bottom, two pieces with holes for wires on sides and two extra pieces to cover those holes. Each piece had two aluminum stripes with holes going with them. They are for load distribution as lead is very soft material and screws just sink in it when tightened.

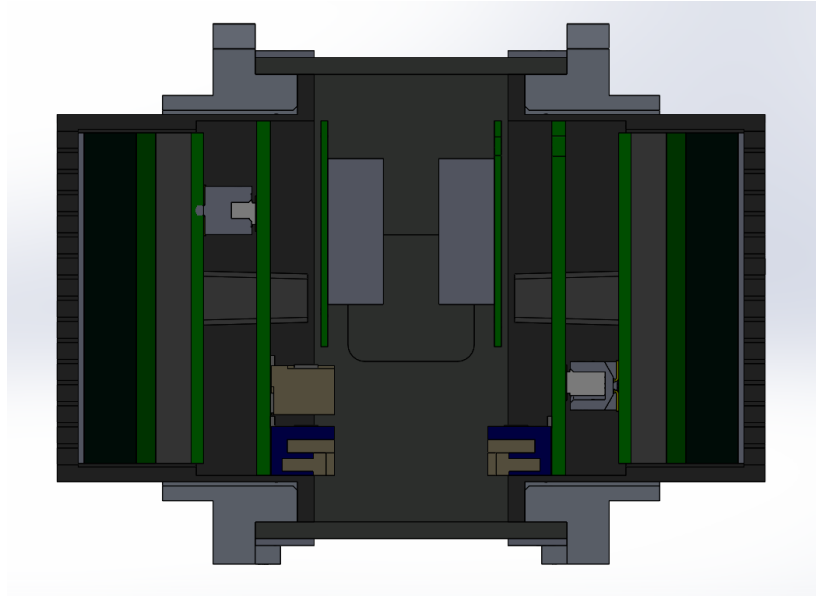

Figure 3.5.7-5: Cross-section of payload assembly for analysis  
of incident angle of photons

C&DH was moved outside the lead shielding. Reasons for that are purchasing radiation tolerant SD card, avoiding complicated assembly and desired increase of accessibility. After C&DH was placed on the top of payload assembly, radio was moved from antenna plate to payload mounts as well. It is settled on the bottom of payload assembly and has three hole sets for different mounting positions. This change resulted in better heat dissipation from radio, more reliable mechanical connection, more efficient use of space and simpler assembly process. Negative side in this change is that payload and radio as relatively high heat generation units are bound together and require sufficient heat dissipation as performance of these systems is temperature-dependent.

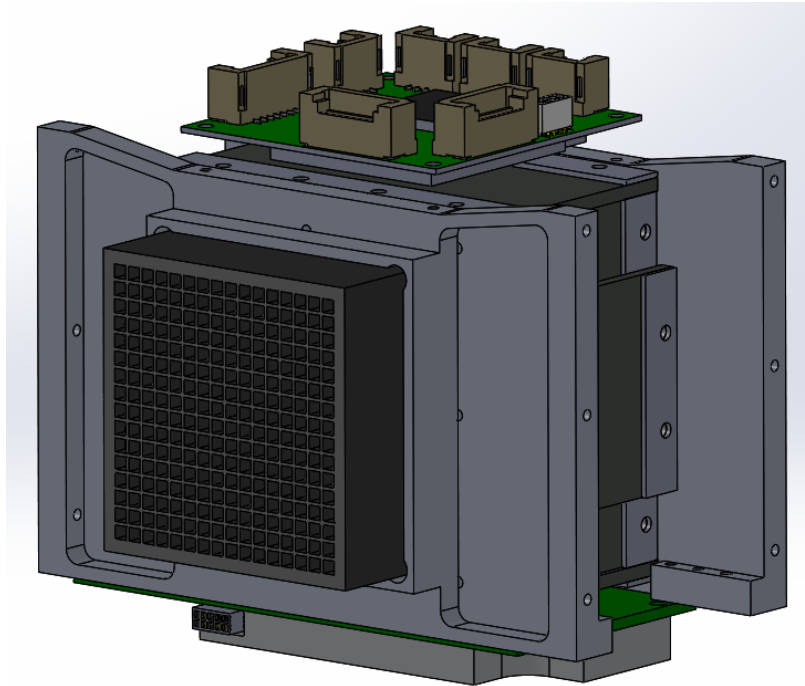

Figure 3.5.7-6: Payload assembly with C&DH and Radio

Design of payload support went through a lot of iterations and finally it serves primary purpose and allows mounting several other components on it:

- Detector assemblies
- Collimator
- Lead shielding
- C&DH
- Radio

Detailed assembly algorithm is described in integration section.

### **3.6. Thermal control system**

Requirements for thermal regulation system were set by payload. CZT detectors performance depends significantly on their temperature. Higher temperature cause appearance of noisy pixels

and data acquired gets distorted. Each detector generates 1W of heat that needs to be dissipated. First solution that was found is double-deployable radiators on opposite sides of SC. Radiators were located on side panels and connected with custom-made miniature hinges with springs. Thermal path from walls of collimators to radiators was provided by flexible copper foil. Thermal analysis was provided by Yendler Satellite Propellant Management (YSPM) that showed that this setup would work but there was high probability of overcooling the system in shaded regions of orbit. Then Phase Changing Material (PCM) pouch was suggested. PCM would provide smoother temperature change in transition between shaded and illuminated parts of orbit and change in payload operation cycles. Unfortunately, only PCM that was available at needed temperature range was a toxic material. As long as satellite is deployed from the ISS, manned space station, PCM option was eliminated.

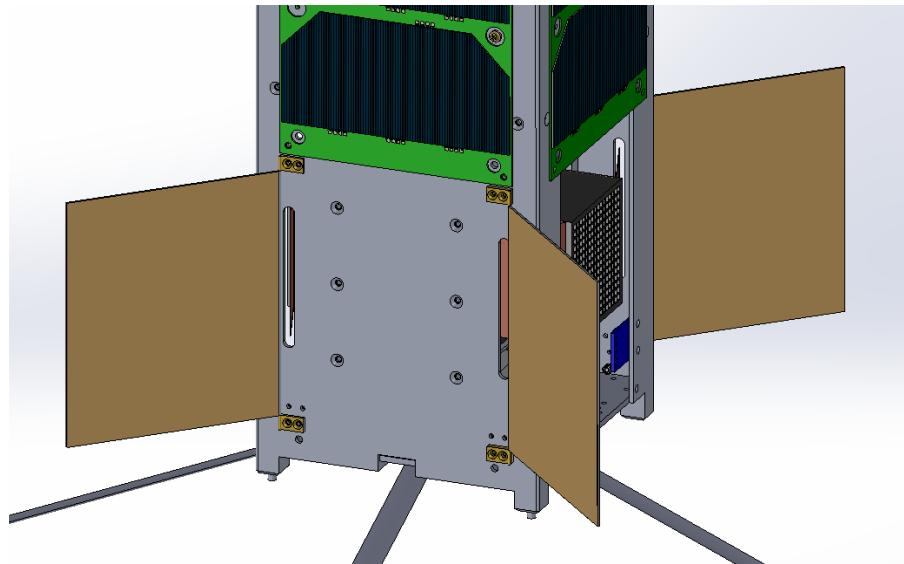

Figure 3.7-1: Deployable radiators

In the end, only thermal regulation method that remained and was evaluated as sufficient was radiative emission of heat from surfaces of spacecraft side panels. This led to decision of color of anodization which is black.

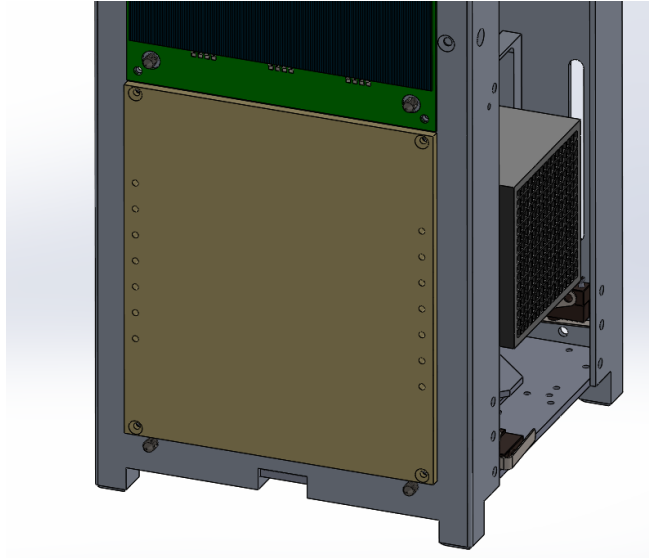

Figure 3.7-2: Radiator with PCM

To ensure thermal conductivity between CZT detectors and collimators, thermal gap pads were used and process of installation is discussed in integration section. Heat from collimators to payload mount is conducted through aluminum filled epoxy.

### 3.7. Materials

All materials were chosen in accordance with Outgassing Data for Selecting Spacecraft Materials prepared by NASA. Its database contains information on materials used by Goddard Space Flight Center and information about properties like outgassing, operational temperatures, and its applications.

Aluminum alloy 6061-T6 was chosen for frame parts because it is easier to machine. Kapton tape with acrylic adhesive is commonly used in space industry for its low outgassing. Other adhesives used were aluminum filled epoxy and threadlocking anaerobic liquid compounds like Loctite and Vibrotite which are also commonly used. All fasteners are 318 stainless steel. Deployment switch pins are 3D printed ABS plastic. Collimator was 3D printed of tungsten

powder with polymer filling. Shielding was made of lead. Copper tape was used for RF shielding and for protection of some internal components from direct sunlight and atomic oxygen. Wires and cables have Teflon insulation. PCBs for all subsystems is glass fiber composite. Thermal pads are Bergquist Gap Pad. Switches housing is phenolic.

### **3.8. Fasteners**

When structure is being designed, proper fasteners have to be used for mechanical connections. Some of the fasteners were used for alternative purposes, which are hook for monofilament, solar panel alignment cones, solar panel deployment angle limiters, spacers as fillers for cutouts on SP hinges, RBF pin. This is done to use and repurpose as much COTS parts as possible for price reduction and avoiding extra manufacturing. Fasteners that are used for CXBN-2 are mostly made of 318 stainless steel, spacers and standoffs that are made of 2011 aluminum alloy and electrically insulative phenolic washers. Structure designing includes an idea to use as least amount of fasteners as possible. This made integration easier and reduced overall mass. Appendix B has a list of fasteners, their types and masses and purposes they served.



## 4. CHAPTER 4.

### 4.1. Manufacturing

#### *Machining*

Every part design went through thorough adaptation for machining. Parts do not have sharp inside corners so that 4mm mill cutting bit could be used for most of the geometry. Thickness of walls is at least 1.5mm. Number of different hole diameters, thread sizes and screw hole types is minimized. Crossmembers are the same and two side panels are identical, as well as payload mounts. Machining in-house was not possible because experience and equipment would result in lead time that was too long for this project. Side panels, crossmembers and payload mounts were machined out of 6061-T6 aluminum alloy.

During integration payload mounts were redesigned and it was important to machine it as fast as possible. All local shops were booked for weeks and closest estimated delivery was in one month. Those who offered faster machining were requesting prices that were above budget. Foreign machining shops were researched as well and one of Chinese machining company called Smart Prototyping agreed to machine payload mount with lead time 10 days including shipping. Parts were received on time. Six parts were ordered and only four were of sufficient quality but still required some finishing.

L-bracket was intended to be machined out of a standard 1"x1" 1/8" thick extruded aluminum angle for cost reduction and time saving. After several failing attempts to perform this job at machine shop at the SSC, 8 pieces were machined at Rowan Campus of Maysville Community&Technical College using FANUC Robocut wire EDM.

Antenna plate was machined out of aluminum in-house. It was made of standard 1/16" sheet and had pattern of cutouts for antenna blocks, for monofilament cutter and a set of threaded M2 holes. After several attempts, it was successfully machined and matched requirements.

### ***3D printing***

Because of complicated design of collimator, 3D printed collimator as the only one reasonable solution for this mission. After long research H.C. Stark of Euclid Ohio was found. They concluded that this part could be printed with tungsten polymer blend. The only drawback of this was the company could not guarantee quite the tolerances desired for the design as manufacturing method with this material was experimental. But after several attempts company managed to produce eight collimators though some of them had different masses and properties as tungsten powder/polymer mixture was changed.

Pins for deployment switches were also 3D printed which was the easiest and fastest solution for such a simple part that also had to be lightweight.

### ***Post-machining***

Even though this part was machined by another company professionally, it required post-machining modifications that simplified machining process and reduced overall cost for the service. For side panels, hinges were drilled and tapped to fit hinge pin and edge where antenna bends and touches was rounded. For crossmember, additional modification that was made during integration by request of subsystems developers is two cutouts for connector extensions on the top crossmember. Cutout is placed in the way that it would be impossible to incorrectly connect special JTAG connector for EPS programming port. Second connector is only for charging

batteries. Polarity was controlled by filling empty pin slots with epoxy in a way that inserted connector had only one possible position. Both cable extensions were then inserted in slots and secured with strong thread. Thread is used instead of epoxy because it is strong enough, takes very little time to be wrapped and tightened and is easily removable for disassembling. The rest of modifications are described in integration section.

### ***Anodization***

Side panels of the spacecraft had to be hard anodized per requirements of NanoRacks Deployer ICD. Parts were sent to Fort Wayne Anodizing and received black Type III hard anodization. Later anodization was removed from some areas of frame to provide better electrical connectivity between structural members. Anodization removal process is described in integration section.

## **4.2. Integration**

Space Science Center has a Space Systems Development Laboratory. It is 5000 sq.ft. area that is called High Bay. It accommodates a lot of work benches for different processes of development and fabrication of space systems and components. Testing equipment like vibration table, EMI/EMC testing Faraday cage, thermo-vacuum chamber are standing along the perimeter of the room. In the middle of High Bay is a Class 10000/1000 Clean Room. It is a 2000 sq.ft. Clean Room where all integration and final assembly of spacecraft take place.



Figure 4.2: Morehead State University's  
Spacecraft Environmental Testing Laboratory (SETL)

Clean Room went through preparation before beginning of CXBN-2 integration. It was cleaned one more time, air filters were changed and after several weeks of blowing air out it went into clean mode. After that team members were required to be extra cautious like wearing shoe covers or being barefoot, controlling contamination of work area with dust or other contaminants. Specific procedures like epoxying, soldering, adhesive application and cutting/grinding had to be conducted in dedicated work areas. Sufficient ventilation over work stations was critical as highly volatile cleaning chemicals and solvents were used extensively.

Following ESD protocol was most critical. Every electronic component of the system is extremely ESD-sensitive as it is custom made without intended internal protection. Each member of integration team had to go through ESD safety training and be prepared to be extremely cautious. Wearing ESD wristbands was mandatory at all times while directly working on assembly or being even close to SC electronics. Every work bench was covered with ESD mats that are made of electrostatic dissipative material. All mats were grounded and each of them had several wristbands connected to it. Clean room was equipped with ESD-safe furniture as well as tools that were reducing risks of generation and accumulation of electrostatic charges.

To make any assembly process go a lot smoother and even enjoyable a good set of tools must be present. A set of tools was prepared that included ESD-safe screwdriver sets, different types of pliers, xacto knives, different types of alligator forceps, files, soldering stations, scales, accessories for mixing epoxy, lights for extra illumination and even dental teeth pullers were used to safely remove connectors. To help organizing parts, fasteners and tools, several boxes and labeled hardware storage cabinets were used. For some volatiles and chemicals like MEK, epoxy hardeners, liquid threadlockers, isopropyl, safety items like gloves, respirators and goggles were required.

Section 3 of NanoRack ICD has a list of general requirements for CubeSats. Section 3.5 says that CubeSats shall use a secondary locking feature for fasteners external to the CubeSat chassis and that acceptable secondary locking compound is Loctite. At Structural Engineering Division – Material Branch at Johnson Space Center - Houston, Texas was created a report by Rajib Dasgupta “Fastener Retention Requirements and Practices in Space Flight Hardware”. This report described different fastener retention methods and conclusions that were taken from there say that lock washers are not efficient locking method and shall not be used for space applications. Also, comparison of Loctite and Vibrotite thread adhesives showed that Loctite has good locking characteristics and Vibrotite ones are not recommended for use. NASA-STD-5020 “Requirements for Threaded Fastening Systems in Spaceflight Hardware” describes methods of fastener retention and best applicable for CXBN-2 design are anaerobic adhesives. They cover threads and limit fasteners from getting undone. So, two features used on all screws are preloading and use of anaerobic adhesive like Loctite 272 Red and Loctite 290 Green. Bottoming holes shall be avoided as it doesn’t let adhesive to dry.

For making assembly process easier, having better access to most parts inside the SC, testing the deployment system, vertical and horizontal assembly stands were 3D printed. Horizontal stand is used for most of the assembly procedures when one of the side panels is not attached. Horizontal stand is used mostly for final solar panel assembly steps, testing of the deployment system and observation of the whole system while verifying correct operation of subsystems.

Before actual assembly of the whole satellite several structural components were put together with subsystems models. First reason is to check again if everything fits together without any problems. Second reason is to understand the best sequence of putting everything together and create assembly algorithm.

#### ***4.2.1. Assembly process***

##### ***Solar array***

Whole process starts with assembling solar panels. PCBs and hinges had to be epoxied to each other. This required a high level of accuracy. For this purpose, several assembly templates were made. First type of template is used for adding a chamfer on the edge of PCB. It is a 3D printed block that has a big chamfer on one side that aligns PCB at an angle. Second type of template is an assembly template for epoxying stage. It is 3D printed and has all features to align hinge with PCB like extrusions that match holes on the PCB and cutouts for steel pins that align hinge.

Solar panel assembly starts with preparation of parts. PCBs are first being covered with painters tape to protect its surface from any damages as it needs to stay clean and smooth for later application of solar cells. When PCB is placed on template it stops at an angle of 12.5 degrees. Holding part at the same angle, it is being sanded with a sand paper to achieve 1.3-

1.4mm thickness of material on that edge. These manipulations are made for best fitment of hinge on PCB because shape of that hinge doesn't allow them to be flush to each other. PCBs are being sanded to achieve required chamfer. Hinge that was delivered as a big assembly with pin, gets disassembled and cut into pieces to match width of solar panel which is 82mm. Three knuckles are left on each hinge so that center of middle one is aligned with a center of symmetry of the hinge and a center of symmetry of the PCB. When part is cut, it is being tested with the pin for resistance when turning. If even small resistance is present, hinge is either discarded or fixed by bending or enlarging knuckle hole diameter. After that all selected hinged go through surface roughening. Adjacent with PCB surface receives a set of cuts that increases grip in epoxy joint.

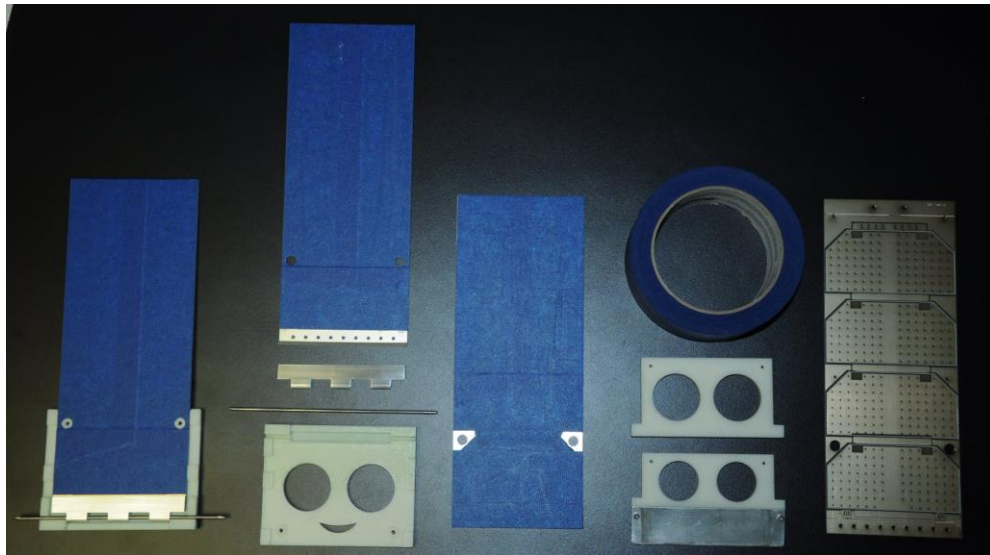

Figure 4.2.1-1: Solar panel preparation stages prior to epoxying

When epoxying of solar panels, templates are covered with epoxy release solution. Mixed epoxy is pre-applied to PCBs and hinges. Then using 60 grit sand paper, adjacent surfaces of either parts are being wet-sanded. This steps adds roughness to surfaces and removes oxide layer from aluminum hinge that increases bonding strength. Excess epoxy is removed and parts are

placed on the assembly template. Then it is pressed with C-clamps. Extra epoxy is squeezed out and need to be removed. After epoxy cures for 18-24 hours, parts can be extracted from templates and alignment pins can be removed. This assembly the goes through cleaning and removal of rests of epoxy and epoxy release.

Several tests showed that this epoxy joint is not strong enough when flexing deformations of PCB occur. Hinge peels off when applying enough force to the edge. This problem has been solved by threading and tabooing holes in aluminum hinge and adding M1.6 screws with Red Loctite.

It his point panels are ready for solar cells. AzurSpace solar cells are being mounted onto PCBs with double-sided Kapton tape and then tabs being soldered to terminals. This is done for both deployable and body-mounted solar panels. Then they go through bake-out in thermo-vacuum chamber. When bake-out is complete, each panel is reverse-based to verify correct and proper connection and reject non-working solar panels.

After solar panels are tested, assembled L-bracket with clinching nut and a screw are mounted onto solar panel with two M2 screws. Then both two- and four-cell panels are installed on a SC frame. Jumper cables are soldered between panels' terminals and shaped so that they don't brake and avoid contact with solar cells when folding solar array. Final step in assembly of solar array is angle-limiting screws. They are screwed into the structure and adjusted so that deployables stay at 15-degree angle to the frame. Then epoxy is applied to screws to keep them in the same position.

This algorithm can be simplified to these steps:

- 1) Preparing PCBs - sanding, rounding edges, fitting to hinge curvature.
- 2) Cutting hinges to the width of solar panel



- 3) Roughening surface of hinge
- 4) Epoxying
  - a) Wet sanding
  - b) Using 3D printed templates for correct pcb-hinge positioning
  - c) Checking if pin slides freely
- 5) Drilling and taping hinges and installation of small screws with red Loctite
- 6) Cleaning and preparation for solar cells
- 7) Soldering solar cells
- 8) Bakeout
- 9) Reverse bias
- 10) Screwing down the L-bracket retainer with Loctite
- 11) Mounting all solar panels on frame
- 12) Solder cables
- 13) Adjust angle limiters

When the rest of structure was being put together with 3D printed subsystem models, it was proven that assembly had to be performed in a specific order. Assembly algorithm of CXBN-2 frame was created as a list of actions that should be performed to assemble a whole spacecraft.

### *Side panels*

When side panels were received from machining company, they went through extra post-machining modifications. Hinge extrusions had holes that were not wide enough for hinge pins. They were widened to fit pin without any play. Pin had to be retained from sliding out of the hinge and it was achieved by placing set screws in each of the ends of these hinge extrusions.

Drill bit increased a size of that hole and went only 3mm in depth of pin hole. Then bottoming tap was used to make M3 thread for set screws. Additional hole was made and tapped where RBF pin switch went. It was made to attach switch in different orientation that would give extra room for changes in battery board. Another modification was made to a cutout where folded antenna goes. An edge where antenna lies in folded position was too sharp and could permanently damage it. Edge was filed and sanded down to create smooth curved contact surface for antenna blade.

### *Switches with cables*

RBF pin controls main power switch of the satellite. It is mounted on +Y side panel. Separation switches were mounted on side panels, two on +Y side panel and one on -Y. When approximate diagram of cables was created, cables between switches were laid out so that their length is minimal. Then cables were soldered to common and normally closed terminals so that when spacecraft is deployed, switches close circuit between batteries and EPS. All deployment switches and RBF switch are connected in series in the same circuit.



Figure 4.2.1-2: 1SX1-T Honeywell microswitch

RBF pin was made of brass screw and a rounded nut. End of a screw was tapered that allowed to use it to push on RBF pin switch actuator smoothly. This design has several benefits.

It is very simple and inexpensive, compact; pin can not be accidentally removed but has to be unscrewed.

### *ACS*

Because of a specific shape of magnetorquer brackets, ACS had to be placed on crossmember so that it's flush with PCB. Then ACS is turned 90 degrees to normal position so that cutouts on PCB align with wire cutouts on crossmember. Then it is secured with four M3 screws, washers and green Loctite.

### *EPS*

Batteries were cleaned from factory insulative coating and wrapped with Kapton tape. Six M2.5 hex male standoffs were mounted on the PCB. Two pieces of double-sided tape were placed on the circuit board. Batteries were oriented between standoffs and adhered to the PCB, so that each negative terminal was pointing in opposite direction. On top of batteries were mounted two aluminum blocks to standoffs with M2.5 screws. To reduce risk of shorting two batteries, these aluminum blocks were removed and the same PCB was mounted on top with use of double-sided tape to batteries and M2.5 screws to standoffs. Then battery assembly is placed on the inside of crossmember with M3 screws, washers and green Loctite.

EPS board was designed without considering space limitations and shape of crossmember cutouts, so it was impossible to be mounted flush to the top of square bracket. Round spacers were used to offset EPS board. And it was mounted with M3 screws, washers and green Loctite.

EPS together with battery assembly were mounted on side panels in orientation that EBS was facing in +Z direction and batteries were closer to payload. This orientation didn't allow access

any cable connections on EPS as it was blocked by side panels and body mounted solar panels when spacecraft was assembled and was going through testing. So this assembly was reoriented. It was a very simple change because hole pattern on side panels allows crossmembers to be flipped. As a result, access to connectors was open, length of most cables from EPS to other subsystems decreased significantly.

### *Payload/C&DH/Radio assembly*

During first steps of integration, a CZT mount version 7 was used. At that time, it was impossible to use collimators with detectors as they were still being tested and in pre-assembly stage. When payloads were ready for attachment, another problem was revealed. It was experimentally discovered that 3D printed collimators are very fragile. Mounting holes and its flange were cracking under light torque from fasteners even with bigger washers. When aluminum rings were tried that would distribute load more evenly, it didn't work either.

Considering this problem, redesign of payload mounts started again. An extrusion that collimator can be slid in was created. Its purpose is to support thin and fragile collimator walls. On the side where collimator goes, a flat flange is located for positioning via holes. This change didn't leave any space for C&DH board inside the shielding, so it was placed on the top of payload bracket. But now there was no space for cabling from C&DH as EPS was too close after EPS/Battery assembly was flipped. Payload mount went through more design changes that moved payloads further in -Z direction. Thus, Payload mount version 9 was created. After 10 days of lead time, 6 new parts from Chinese machinists were received. Only 4 parts were barely fitting correctly and were of sufficient quality.

Preparation for payload assembly started with extra modifications for payload mount. Before epoxying parts together, they have to have their surfaces roughened to make bonding stronger. On the inside on the opening of mount, several cuts were made just like previously for solar panel hinges. Then all holes were covered with small pieces of Kapton tape to protect threads from epoxy. M2 set screws were inserted for aligning collimator in its desired position and protection of threaded holes from epoxy. Collimator and mounts were thoroughly cleaned with MEK. Areas of collimator that had to be protected from epoxy were covered with painters tape. After mixing epoxy and waiting for 10 minutes to let it become more viscous, it was spread on bondable surfaces of both parts. Then collimator was slid inside the opening. Set screws were removed and covered with epoxy release gasket and aluminum ring were put on top with M2 screws to compress collimator in its place. Then this assembly was flipped and extra epoxy was added to the joint, creating a smooth chamfer around the edge. Excessive epoxy was cleaned with MEK and parts were let sit for 24 hours until curing was complete. Now masking tape, screws and gasket could be removed. Parts required extra cleaning. Same process was repeated for another mount and collimator. This method also let cracked collimator to be used for EM as its flange was no longer a main stress point.

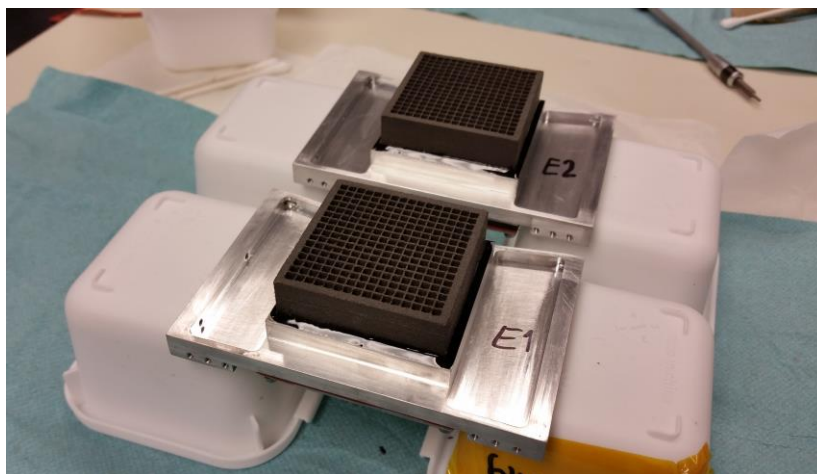

Figure 4.2.1-3: Epoxied collimators

When collimators are epoxied with payload mounts, they're ready for installation of CZT detectors. During operation detectors generate 1W of heat each which has to be dissipated through structure to external surfaces and radiated into space. To make this happen, thermal pads were chosen for heat conduction from detector to internal collimator walls. Four walls of detector where CZT material is exposed were covered with thermal pads. On the bottom of collimator, a thin sheet of aluminum was placed to protect detector from damage from atomic oxygen and direct sunlight. Afterwards detectors were slid into collimators and secured with little drops of epoxy.

### ***Lead Shield***

After detectors are settled in collimators, they need to be shielded. Cables are connected to epoxied Payload A (PL-A) and Payload B (PL-B) which are cables *1, 1a, 2, 2a, 3, 4*. Each cable connector is secured with a little drop of epoxy. Then top and bottom lead pieces are put in place on PL-A with aluminum strips, M2 washers and threadlock-covered screws (except for the screw holes for side-cap smaller shield). Screws are not tightened yet and left loose. Wires from PL-A and PL-B are drawn through wire hole in Side Lead Shields. PL-B is slid onto the PL-A with Shield. Aluminum strips with M2 washers and threadlock-covered screws are put on PL-B (except for the screw holes for side-cap smaller shield) and left loose too. Then two payload assemblies PL-A and PL-B are together screwed on the side panel using 3 M2 flathead screws for each. This side panel also has two crossmembers mounted on it already. Second side panel is put over it. All these structural components are screwed down completely. At this step bottom and top lead pieces are screwed down tight. Now side panels can be removed and side lead pieces screwed down. Cables in holes are being rearranged to stay flat and small lead pieces are

mounted over wires and secured using washers and threadlock-covered M2 screws. All these manipulations with side panels and loose screws were made to ensure correct alignment of payload brackets. If these steps were left out and lead shield mounted as is, payload mounts would be out of alignment and attachment to the rest of a frame would be impossible.

### *Final assembly*

C&DH had to go through one upgrade. It was decided to mount it on top of payload assembly. As there was very little space between bottom of C&DH and brackets, bottom connector was removed and wires pigtailed to pads on PCB. After they were soldered, epoxy was applied to insure safe connection and protect wires from breaking off of soldering connections. Epoxy should not be applied to actual soldering connection but further between wires and free PCB surface because as experience says, if desoldering is needed - it is very hard to do carefully without damaging tabs on PCB. SD Card was installed and epoxied as well. Inserted cables received a drop of epoxy for the same security reason. Then C&DH is being attached to Payload assembly with screws, washers and standoffs with application of Loctite.

Radio took its place on the bottom of payload brackets where 12 holes were available for 6 possible positions. it was mounted with M2 screws and washers.

Assembly of antenna plate starts with installing antennas with antenna blocks. Phasing board is mounted using the same screws as for antenna blocks. Then solar panel deployment switches are mounted in dedicated places. Monofilament cutter is built out of cauterizing tip and small PCB. Cauterizing tip is placed in vice and brass tubes are bent at a 45-degree angle then being cut off and soldered to PCB. Cutter is placed on top of antenna plate and secured with M2 screws and modified nuts. Then wires are soldered between switches and cutter.

Now there is a set of subassemblies that can be finally put together into the frame. This part of integration was done on horizontal stand. All cross members and payload mounts are mounted on +Y side panel where RBF and deployment switches already located. First goes bare crossmember on +Z face of side panel. Second, ACS with crossmember is mounted further down Z axis with PCB facing +Z direction. Third goes EPS assembly with batteries facing +Z direction. Then fourth subassembly mounted is payload assembly that screwed down with six M2 fathead screws. Two ADS boards that have standoffs soldered on them are mounted so that ADS-A board is on the side where PL-A is and ADS-B is on the PL-B side. Antenna plate is the last internal subassembly that was attached inside the frame.

And this is a good moment to start putting cables in. All wires and cables were cut to their possible minimal length and their path was chosen accordingly. Most cables were captured by structural members. They were passing along side walls between cross members and side panels, and between payload mounts. This kept cables from excessive freedom of movement that could cause damage to any internal components. Cables from deployment switches are soldered to battery terminals. Second side panel is held closely for soldering cable from third deployment switch. For extra security, cables were tied together with strong thread. All cables were secured with a drop of epoxy including RF cable connection.



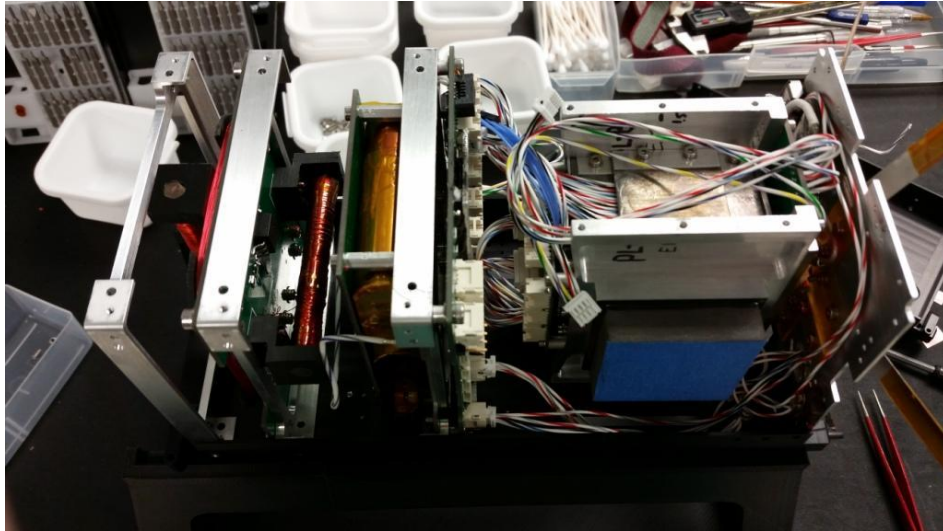

Figure 4.2.1-4: All subsystems mounted on side panel

After all internal subsystems were placed on the first side panel, second side panel could be mounted on and screwed down with M2 flathead screws and Loctite. This closed the structure and next steps of assembly of external parts could be started.

Attachment of solar panels is performed in several steps. Spacecraft body was placed on the horizontal stand. Torsion springs legs receive several bends to have better connectivity with surfaces that are being pushed on. Each one of four solar panel assemblies are laid on the table. Three  $\frac{1}{4}$  inch spacers and torsion spring are put in the openings between hinge knuckles. Then plastic tube or rod is inserted in place of hinge pin. Diameter of flexible tube should be smaller than diameter of pin. Then SP assembly together with spacers, spring and tube is placed on the top of the satellite body. Free part of tube is being slid into hinge hole on side panel. When SP hinge aligns with hinge part on side panel and torsion spring is in correct position, then tube is replaced by sliding in steel hinge pin. Then pin is secured with two M3 set screws. 2-cell solar panel is attached to frame with four M2 screws. In the opening on +Z face cables can be connected to solar panels and secured with a drop of epoxy. This sequence have to be repeated for each solar panel assemblies. This completes assembly of solar array.



Figure 4.2.1-5: Solar panels are attached

At this point integration could be called complete. But there were several problems of different level of difficulty that required disassembly of spacecraft. These problems are discussed below.

#### **4.2.2. *Problems and solutions***

One of the first tests that were conducted after assembly was a cutter test. After a delay of 30 minutes cutter was supposed to receive full power from batteries and cut monofilament. When this happened, cutter tip heated up and cut monofilament which was followed with self-destruction of the tip itself. As it was found out, cutter was not able to withstand supplied current and just melted. This problem was solved by adding resistor to cutter circuit and changing duty cycle. Resistor was placed on antenna plate where two additional holes were made.

Second problem was related to battery charging. There was no access to battery terminals when all solar panels were attached. Temporary solution was charging batteries with solar panels by using several high-power lamps. This method was not very efficient as required a lot of time and was heating up the satellite and everything around significantly. Solution was found and

additional cable just for charging batteries was added. One end was soldered directly to battery terminals, and another end with connector settled on the crossmember at +Z face. This required crossmember modification in form of a little cutout where connector could be mounted and secured with strong thread. Thread was used instead of epoxy because it was easy joint to make, it was fast and strong enough. Only 4 pins were used on connector and to make sure polarity was always correct, it was protected by closing some pin holes with epoxy and making a male connector with specific position of pins so that it could be connected in only one position. Charging cables were marked as positive and negative.

Third problem was with EPS. It didn't work correctly and had to be replaced. Testing showed that several components on PCB were burned.

Fourth problem that was found in a bit was related to EPS programing port. When latest version of EPS was installed, its programming port appeared to be hidden behind structure wall. As software bugs were fixed on-the-go, access to programming port was critical. Attempts to stick cable in very small space were unsuccessful. Then solution was found. Extension cable to programming port was added. Cable was connected to PCB and epoxied to it. Other side of cable was drawn to crossmember on +Z face and connector was mounted in the same fashion as battery charging port.

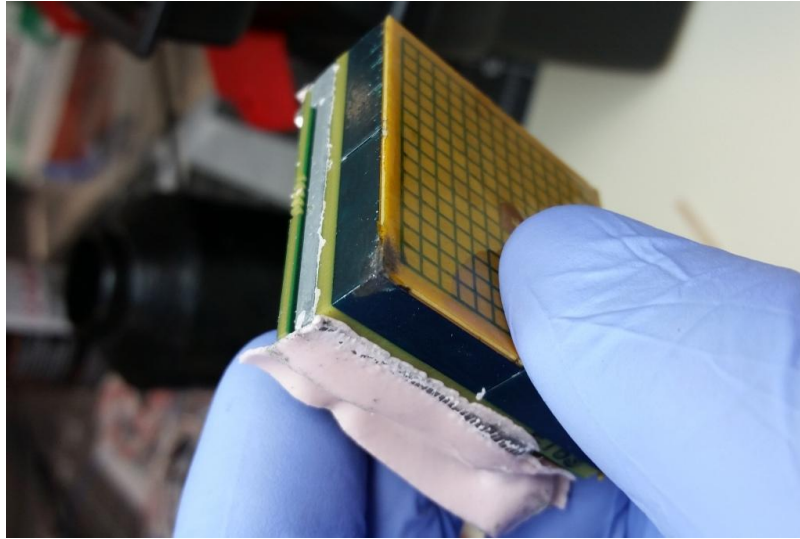

Figure 4.2.2-1: Arching issue with CZT detector

Fifth problem was about performance of payloads. When satellite was tested after SP deployment, it was sending beacons that besides from telemetry contained data from payload. Data was not as expected, and it was evident that detectors have issues. All spacecraft was taken apart and payload was tested on the bench. When it was operating, clicking noise was present and it was decided to extract detectors from collimators. On the edges and corners of detector were noticed dark spots that was a sign of arcing. High voltage power supply generates 600V and when detector was placed inside tungsten collimator without insulation, a spark was created between parts. Also thermal pads were sliding off and thermal conduction was poor. This was solved by putting Kapton tape on detector, aluminum piece and thermal pad was secured on walls of collimator with Kapton tape as well. When parts were assembled back again, detector was fit snugly and secured with drops of epoxy. To add extra security to prevent detectors from sliding out, several layers of thermal pad was added on backs of high voltage power generators so they were pushing against each other when lead shielding was installed.

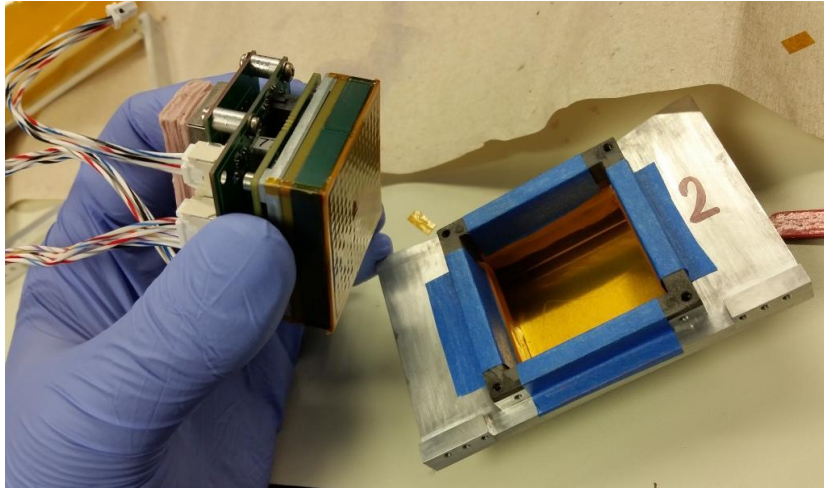

Figure 4.2.2-2: CZT detector and collimator insulated with Kapton tape

Sixth problem was related to performance of communication system. When satellite was assembled and beacons were transmitted, the signal was relatively weaker that it should have. With oscilloscope, it was discovered that a lot of interference was present. A lot of time was spent defining the source of problem. Reason for this interference was bad grounding connection in frame. As side panels were anodized, there was a very insufficient if any conductivity between structural parts. So, solution was to remove anodization layer in places where contact between metal parts of structure was occurring. First it was suggested to mechanically remove oxide layer with dremel tool. But there was a risk to cut too much material off that would change critical tolerances of structural dimensions. Then better solution was found – to remove oxide layer chemically. Simplest and cheapest solution was to use heavy duty oven cleaner. Side panels were masked with painters tape except for the areas that needed to be treated. In four stages of application anodization was removed from needed areas. And as a result, every structural component was properly grounded. It helped significantly reduce interference but some interference was still present. Then additional actions were made one at a time. RF cable received ferromagnetic bead, antenna plate components were shielded with grounded copper tape

and power and data cables that went from radio to EPS and C&DH were covered with grounded shielding braid. This finally solved the problem, interference was dramatically reduced and signal strength increased to match what was expected.

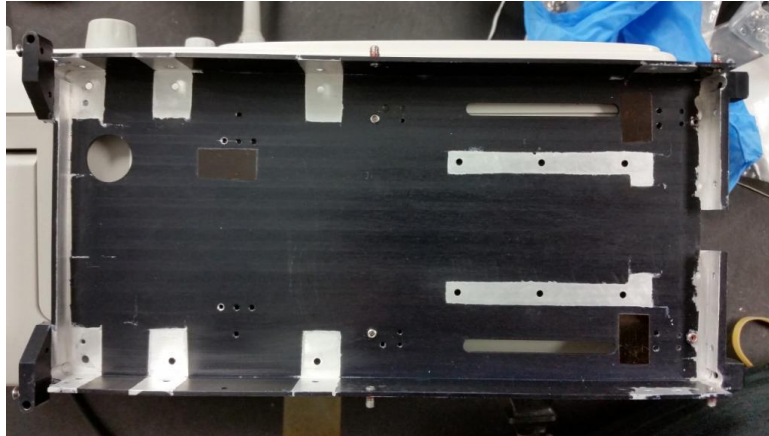

Figure 4.2.2-3: Removal of anodization

This are the biggest problems that appeared but there were a lot of other smaller issues like parts were not fitting properly with each other because of machining quality that required grinding and filing, Vibrotite VC-3 threadlocking compound was not performing well enough and caused tolerance problems, connectors were falling apart because of multiple connections-disconnections and other fitment issues as a result of unexpected design changes during integration. Each of the problems was discovered separately that led to complete disassembly and assembly of spacecraft.

Assembly process and problem solving discussed above was mostly experienced with engineering model which purpose is to find all possible design and integration issues, eliminate them and proceed with integration of flight model without any complications. Integration of flight model was conducted in the same sequence after all issues were already solved and taken into account.

## 5. CHAPTER 5

### 5.1. Testing and results

#### *Day in life testing*

One of the main requirements for the mission is to ensure the safety of all satellites during launch, deployment and extremely early operations. "Day in the life" test procedures have been developed to simulate on-orbit deployment of the satellite allowing to test compliance with the following requirements:

- Deployables Constraint
- Deployables Time Delay
- Electrical Power State
- Deployment Switch Function
- Remove Before Flight Pin Functionality
- Transmit Telemetry and Data Over RF
- Receive Commands and Execute Over RF

The testing requirements described would verify that the CXBN-2 spacecraft would not fail under the flight environmental conditions as defined by the NanoRacks CubeSat Deployer (NRCSD) Interface Control Document (ICD).

The CXBN-2 functional testing was conducted at Morehead State University's Spacecraft Environmental Testing Laboratory (SETL). The spacecraft was maintained in the onsite class 10,000/100,000 clean rooms while a simulated UHF Earth station was set up approximately 15 meters from the spacecraft.



Contamination and ESD requirements were established. To ensure mission success every action was taken to keep the spacecraft free of contamination. With this in mind all day in the life testing occurred within the SETL.

A system verification testing procedure were conducted both before and after day in the life testing to ensure functionality. Both pre- and post-verifications were included in the final test reports.

All data from testing was captured by technicians running the day in the life test to ensure verification of the ICD state requirement.

Simulated mission benchmarks and spacecraft systems deployment events (antenna and solar panel deployment) were videotaped with an experiment clock running in the background to document and verify mission times associated with specific events.

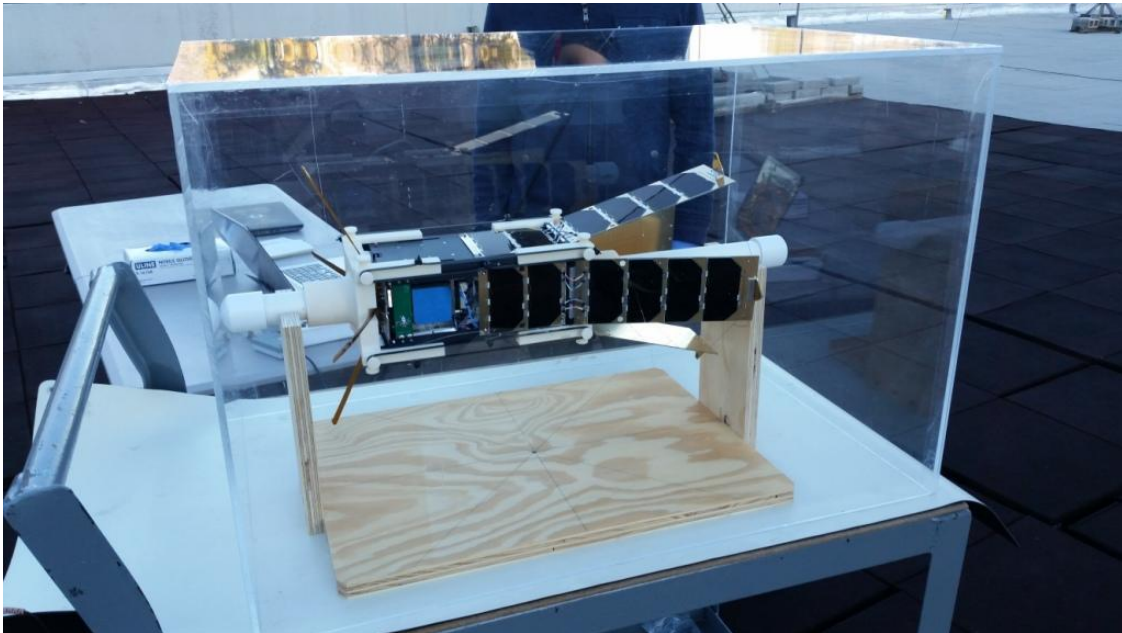

Figure 5.1-1: CXBN-2 in Magneto box. Day in life testing

Data from the simulated Earth station (UHF beacon, data packets, and telemetry packets) were recorded and submitted in the final test report.



Day in the Life Testing was conducted in accordance with prepared procedure:

1. Transfer spacecraft to roof of SSC in Magneto Box
2. Prepare spacecraft for testing- mount on vertical stand
3. Initiate start-up procedures of Simulated Earth station- GSW installed
4. Initiate Earth station software
5. Set external mission time clock to  $T = 0$
6. Initiate videotaping of test
7. Ensure spacecraft is ready for testing- FSW installed
8. Depress spacecraft footswitch and secure in locked position with Kapton tape
9. Remove RBF pin
10. Record Beginning Time of Test
11. Simulate deployment by removing Kapton Tape from deployment pins. Simultaneously initiate external mission time clock
12. At  $T + 32$  minutes verify that cutter actuated, heats up and releases deployables by cutting monofilament restrain
13. Acquire spacecraft beacon with simulated Earth station
14. Record State of charge
15. Mount Horizontally and cover with Magneto Plastic box
16. Simulate 92 minute orbit using sunlight and cover- Expose to Sun for 50 minutes to simulate sunlight component of orbit
17. Cover for 40 minutes to simulate eclipse
18. Uncover and reposition to maximize sun angle
19. Repeat as many times as possible during sunlight hours

20. Ensure telemetry and science data is received
21. Expose Detectors Periodically with Radioactive Sources
22. Power down system
23. Record Stop Time of Test
24. Analyze telemetry
25. Complete end-to-end data processing- produce spectrum from raw data

After test is complete, UHF Antennas was wrapped and secured in stow configuration. Solar panel array was folded and secured in stow configuration. Deployment timer in EPS was reset as soon as system was powered down. RBF pin was reinstalled and spacecraft was configured for storage. Then spacecraft was removed from the Test Setup and placed in clean, ESD-safe containment.

### ***Fit-check***

For acceptance of integration into NRCSD and acceptance for flight, CXBN-2 had to go through fit-check and vibrational testing. Testing procedures and requirements were obtained from NanoRacks-NRCSD CubeSat Acceptance and Integration Record of Assembly (ROA) and NanoRacks-NRCSD CubeSat Vibration Test ROA documents. The tests outlined in the ROA document were performed by NanoRacks representative, Henry Martin.

Photos were taken at all applicable steps of testing. Strict compliance with safe ESD processes was maintained at all times as required.

Testing started with CubeSat Inspection:

1. Perform a visual examination and note any abnormalities or damage of deployer and CXBN-2 with noting all details if damage is present.

2. Remove the CubeSat from any bagging material and place on the integration workbench on the CubeSat RAIL ENDS.
3. Take pictures of each face of the CubeSat (-X, +X, -Y, +Y, -Z, +Z) using the NRCSD coordinate system.
4. Perform dimensional inspection of CubeSat and record following dimensions:
  - Width Rail to Rail Dimension measured from outside rails.
  - Length Rail to Rail Dimension measured from end of rails.
  - Rail Width. 6mm Minimum.
  - Rail end clearance with CubeSat. 6.5mm Minimum. Dimension should be measured from closest feature to plane of rail ends.
5. Record locations of separation switches.
6. Verify the separation switch pins are captive and when compressed are contained within the maximum rail length.
7. Verify the electrical design incorporates a minimum of 3 inhibit switches that can be activated by physical deployment.
8. Obtain Go/No-Go Fit Gage P/N 100271 (Gen2, 3U), 100646 (Gen3, 3U), or 100649 (Gen3, 6U) from controlled storage or shipping container.
9. Verify fit gauge cleanliness. If necessary, clean fit gauge with alcohol.
10. Slide CubeSat through the Fit Gage to verify clearance. CubeSat should not bind through complete length of Fit Gage. Record video of fit check.

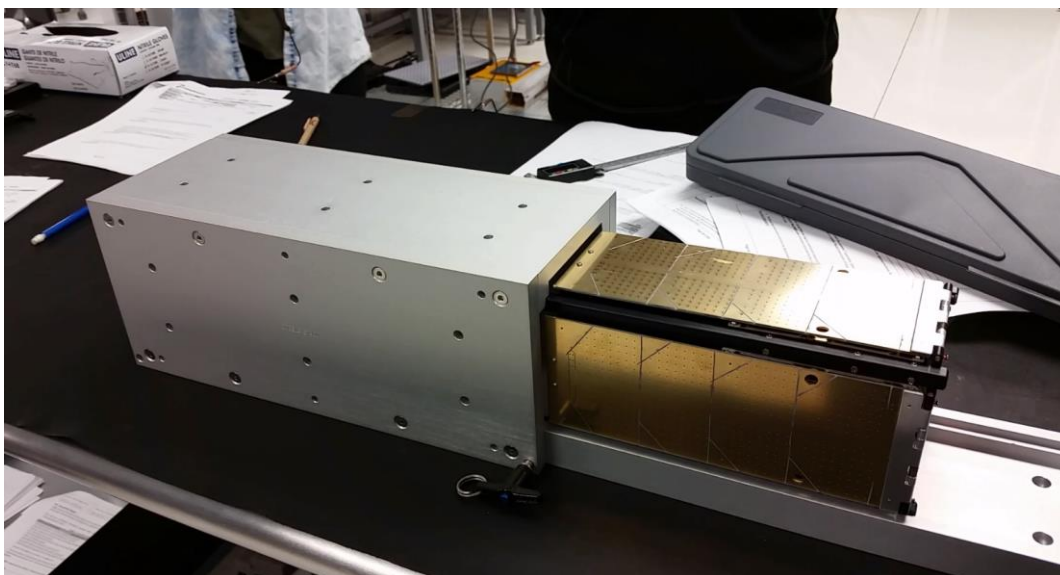

Figure 5.1-2: Fitcheck

11. Record the final mass of the CXBN-2 including information of scale model number / serial number and scale calibration date.

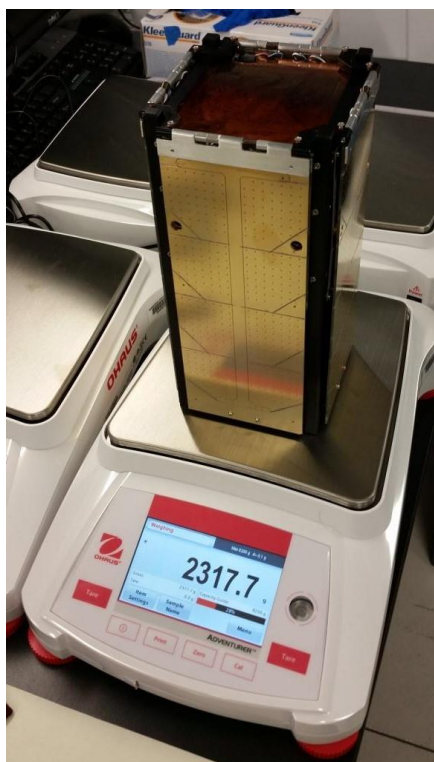

Figure 5.1-3: CXBN-2 on scales

12. Verify that CubeSat flight model matches design documented in safety data submittal. In particular, verify that CubeSat has no propulsive capability (i.e. thrusters).

Fit-check was complete. CXBN-2 went through all measurement and fitting process without any issues and was accepted for further integration and vibrational testing.

### ***CubeSat Integration into NRCSD***

Following procedures describe process of CubeSat integration into NRCSD and preparation for vibrational test.

1. Verify handling procedures for CubeSat and planned positioning and orientation of the CubeSat inside the NRCSD (making sure to integrate in the identical orientation that the deployment test or analysis was conducted in).
2. Verify the RBF pin position and that it can remain in place during integration to NRCSD.
3. Obtain flight NRCSD from controlled storage or shipping container. Then serial number, quad-pack configuration of NRCSD, and Pin Puller serial number are recorded.
4. Verify cleanliness of NRCSD qualification unit. If necessary, clean NRCSD unit with alcohol.
5. Remove the front and rear NRCSD access panels on the +Y face using a 5/64" hex head wrench. Set aside access panel screws in separate containers for the front and back access panel.
6. Verify that NRCSD pusher plate assembly is in the restrained configuration. Ensure that the retainer thumb screw is fully engaged before proceeding (turn clockwise by hand until screw bottoms out).
7. Remove the baseplate retainer screws (QTY: 8) using a 5/64" hex head wrench.

8. Remove the baseplate / pusher plate assembly by pulling on the baseplate retainer bolt.
9. Inspect the inside of the NRCSD through the access ports and baseplate opening and verify cleanliness. If necessary, clean with alcohol.
10. Now NRCSD is ready for CubeSat integration.
11. Insert CubeSat from the back of the deployer (opposite side of the doors). Make sure to load the CubeSat in the identical configuration that is planned for flight. In case of CXBN-2, coordinate system of the satellite is collinear with coordinate system of deployer.
12. Verify that CubeSat slides freely along rails. Slide the CubeSat all the way to the front of the deployer and then back again.
13. Manipulate the CubeSat to extreme positions within the rails and verify that any deployment switches along the rails cannot disengage (listen for mechanical 'click').
14. Verify that there is acceptable envelope clearances between the deployer side walls and the CubeSat side panels. Take pictures of all 4 sides.
15. Insert CubeSat from the back of the deployer (opposite side of the doors). Make sure to load the CubeSat in the identical configuration that was planned for flight and fit-checked. Take picture of this configuration.
16. Slide the CubeSat to the front of the NRCSD so that it is coincident with the doors.
17. Insert the flight spacer into the back of the deployer (opposite side the doors) and slide along the rails until it is coincident with the adjacent CubeSat.



Figure 5.1-4: Satellites integrated into NRCSD prior to vibrational testing

18. Obtain base plate / pusher plate assembly and ensure that the retainer thumb screw is fully engaged. Reinstall the base plate assembly with the eight (8) base plate retainer screws and torque to specification 6 in-lbs using a 5/64" hex head wrench. Note, there are six (6) countersunk / flat head screws and two (2) button head screws. Install button head screws into holes with no recess.
19. Remove pusher plate retainer bolt by rotating the thumb screw counter-clockwise until it is no longer engaged with the pusher plate.
20. Install NRCSD jack screw into the center of the baseplate (5/16"-24 set screw) using a 5/32" hex bit. Record the length of jack screw used. Size the jack screw length by minimizing the amount of exposed threads beyond the jam nut (that will be installed). Torque jack screw to specification 2 in-lbs.
21. Install NRCSD Jam Nut (P/N: MS51972-2D) onto jack screw. During installation, first hand tighten the jam nut while using a 5/32" hex key to hold the jack screw in position. While using the hex key to secure the jack screw, torque the jam nut to specification 30 in-lbs with a 1/2" wrench. Note, if torque wrench not available, hand tighten (~1/4 turn past snug).

22. Inspect the integrated system and ensure that the CubeSats cannot move within the NRCSD (especially in direction of pre-load; Z-axis). Pick NRCSD up and bias in each direction to verify CubeSats cannot move.
23. Take several pictures of the integrated assembly through the access panels of the NRCSD. Verify that RBF has been removed. Verify final position of CubeSats / spacers inside NRCSD.
24. Install front and rear NRCSD access panels with 5/64" hex wrench. Torque to specification 6-in-lbs.
25. End of integration procedure.

CXBN-2 was integrated into NRCSD following all procedures and verifications and was ready for vibration testing.

### ***Vibration testing***

To proceed to vibration test, all procedure had to be repeated and mass model or second CubeSat had to be integrated instead of spacer. Then loaded deployer was moved from clean room and placed on the vibration table. Special adapter plate was made to mount deployer on vibration slip table in different orientations. Bolts were tightened to 55 in-lbs.

Vibration levels and duration for each independent axis were taken from the NR-SRD-139 Flight Acceptance Test Requirements for Lithium-ion Cells and Battery Packs document.

Testing was performed in 3 steps which included random vibration tests of the X, Y, and Z axes.



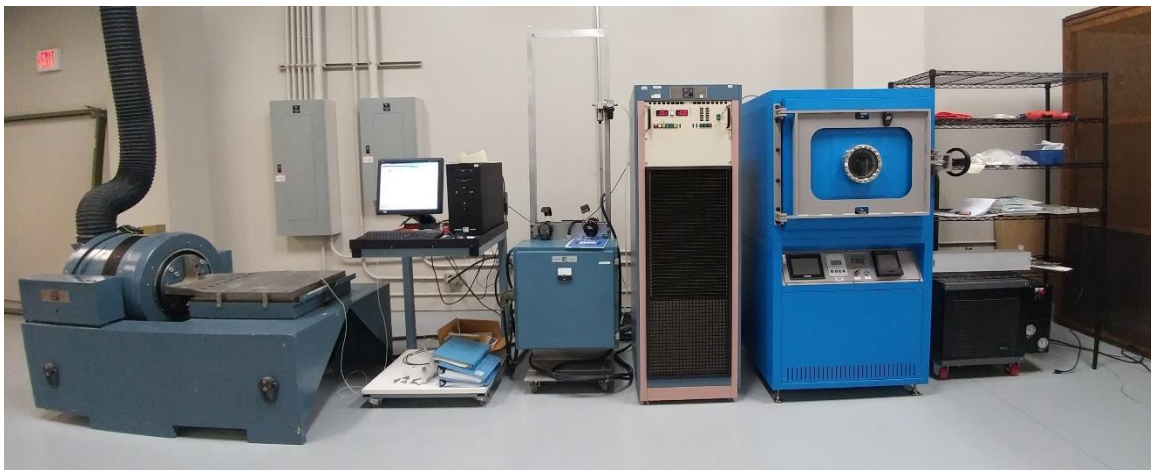

Figure 5.1-5 : Morehead State University Environmental Testing Laboratory (SETL)

Table 1 below lists the instrument names and descriptions of the hardware used for vibration testing.

Shaker system amplitude uncertainties:

- 10 Hz to 2kHz: +/- 2.1%
- 2 kHz to 4 kHz: +/- 2.4%
- > 4 kHz: increasing to +/- 3.3% at 10 kHz

Table 1: Vibration Testing Equipment

Instrument Name	Description
Shaker System	Unholtz Dickie Electro-Mechanical Shaker & Slip Table
DAQ System & Controlling Software	Unholtz Dickie VinW II
NanoRacks Provided Interface Plate	Aluminum Plate used as an interface between provided test pod and slip table

Data was obtained from two accelerometers. First was threaded into slip table and used as reference accelerometer. Second was fastened to test pod during each test and was used as measurement accelerometer.

Testing was done in the following order: X axis, Z axis, Y axis.

The vibration test parameters are sourced directly from the NR-SRD-139 Flight Acceptance Test Requirements for Lithium-ion Cells and Battery Packs document.

*Table 2: Test Parameters*

<b>Frequency (Hz)</b>	<b>ASD (<math>G^2/Hz</math>)</b>	<b>dB/Octave</b>	<b><math>G_{rms}</math></b>
20.00	0.028800	*	*
40.00	0.028800	0.00	0.76
70.00	0.072000	4.93	1.43
700.00	0.072000	0.00	6.89
2000.00	0.018720	-3.86	9.65

Vibration testing procedures, equipment and report document were prepared by Graduate Research Assistant Jennafer Grindrod. Test report is described in 161118-CXBN2-VIBTR document.

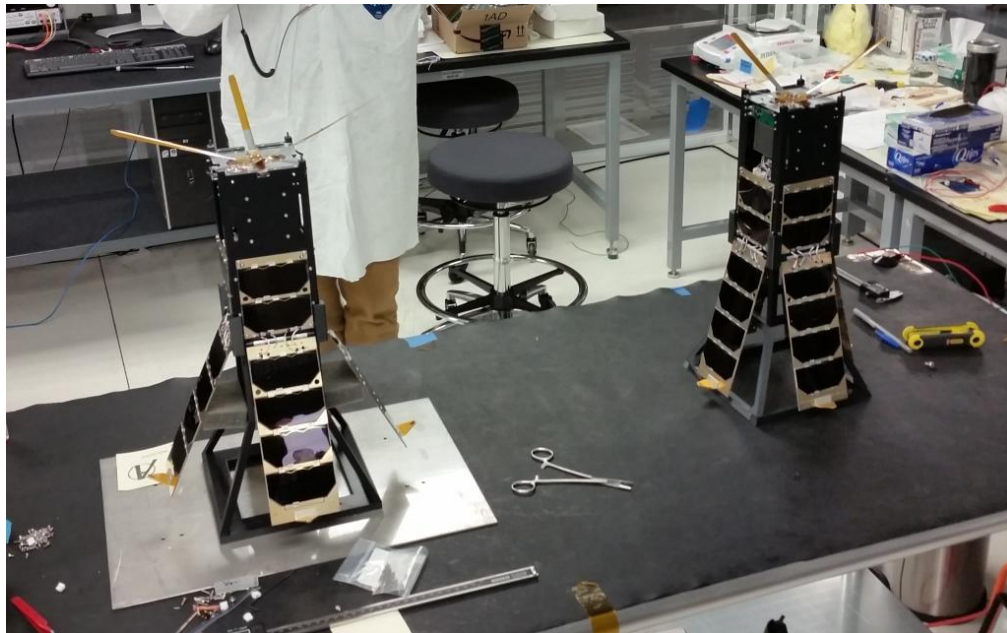

Figure 5.1-6: Engineering and Flight models after successful environmental testing

### *Post vibration*

After vibration testing was complete, these procedures were followed:

1. Remove the CubeSat from the NRCSD and place on workbench on vertical stand.
2. Inspect the inside of the NRCSD through the access ports and baseplate opening. Identify any FOD or loose components present inside the NRCSD and take multiple pictures.
3. Perform a complete post-vibration test inspection of the CubeSat. At a minimum verify the following:
  - a. All deployables stowed and retention mechanisms intact.
  - b. All external fasteners remain intact and torqued.
  - c. All frangible materials (such as solar arrays) are free of any cracks or damage.
  - d. Deployment switches are both electrically and mechanically functional (all switches have sufficient travel and perform their intended function)
4. Take photos of all six external faces of CubeSat and compare to pre-vibe photos.
5. End post-vibe inspection.

After vibrational testing was complete, satellite went through visual and physical inspection. Hardware was not visibly damaged, was not audibly damaged and was not warped or otherwise compromised. CXBN-2 went through vibrational testing and passed all inspection and functionality was successfully tested.

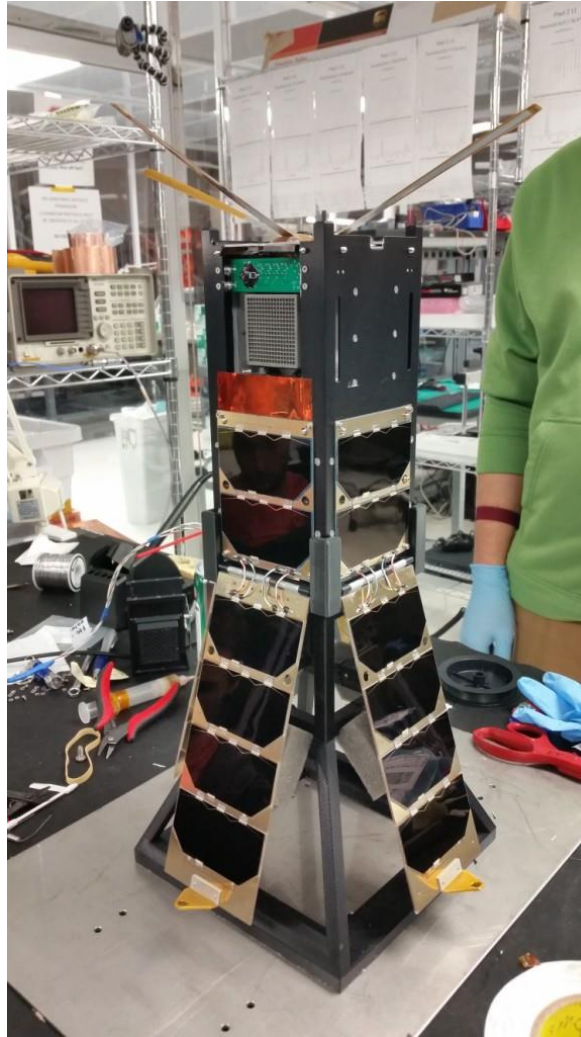

Figure 5.1-7: CXBN-2 Flight model ready for delivery

When all testing and final preparations on satellite were complete, batteries were fully charged, RBF pin was installed, deployables were put in stowed position and secured with monofilament. CXBN-2 flight model was cleaned with alcohol, put into ESD safe bag and packaged in stress-resistant case. Then it travelled to launch provider facility where NanoRacks representatives did final integration into flight NRCSD and was ready for launch to the ISS on April 18, 2017. At a time when this thesis paper was written, CXBN-2 was already on the ISS waiting for deployment in June 2017.



Figure 5.1-8: CXBN-2 is packaged and ready for shipment

## 5.2. Conclusions and lessons learned

### *Design*

When designing any mechanical structure, it is crucial to have mechanical engineering background. During design process, it was noticed that lack of basic engineering knowledge may influence quality of final product significantly. Experience with CAD modelling and CAM is important as time spent on designing parts can vary significantly.

It is very important to work as a team while designing space system. Team leads on each subsystems should have separate meetings to discuss critical design solutions, examples: hole pattern location and size for mounting subsystems PCFs to crossmembers; location of

programming ports as for latest EPS version JTAG connector appeared to be hidden behind the side panel wall; strength of collimator walls and flange was not sufficient for mounting on payload mount that led to redesign of payload bracket and extra machining. Team working was still on high level that is representative for space systems engineers. But members of a team especially subsystem team leads have to be even more careful and more attentive to small details.

Design of current structure can be made even more universal. Issues during integration showed that there have to be flexibility of position of subsystems. Extra mounting holes for crossmembers shall be placed on side panels so crossmembers can be repositioned if any unpredictable fitment issues are discovered. Any possible integration issues shall be considered on design stage.

### ***Manufacturing***

For future missions, it is important to increase professionalism of machining personnel if any parts are planned to be machined in-house. There should be established professional manufacturing environment. There should be people who design, people who prepare detailed machining process and people who do actual machining. Machining technologist should be responsible for preparation of technology of machining of each part. This person shall decide which tools to use, which method and approach to take as well as checking drawings for any issues.

There are a lot of different machining companies. And every company gives different machining prices and lead time. The shorter lead time the higher the price. For missions with limited budgets it is important to consider that lead times are at least 4-6 weeks and plan machining order accordingly with time margin before integration process.

For best results and quality of machining, companies with sufficient experience and reputation should be chosen.

### ***Integration***

It is important to have a log document that is used to note if a part or tool or anything else has been taken away from main assembly table. It should include person's name, time, reason, destination where a part goes and any extra information needed to avoid misplacement.

Workbench where any highly volatile, toxic, dangerous chemicals are being used needs sufficient ventilation. It needs to be directly under the fan. Safety goggles, respirators, gloves and other protection shall be used at any time while using those chemicals.

System has to go through extensive functional testing before any fit checks and vibrational testing. Otherwise if spacecraft has to be taken apart, it validates all environmental testing.

It was discovered that some threadlocking compounds like Vibratite VC-3 should not be used on threads of small fasteners like M2 and M3. It dries too fast and its application is very complicated. An example was discussed in integration section. Vibratite VC-3 is good for use over tightened fasteners and as bonding material for parts or wires that need extra support and movement limitation. Loctite green and red are preferred. High Strength Red Loctite creates very strong bonding and shall be used only for highly stressed threads and fasteners that will never be taken out. Otherwise, tempering with fasteners that used Red Loctite results in stripped threads and damaged parts. Medium strength Green Loctite was used for most connections. It provided sufficient bonding and at the same time fasteners could be removed if needed.

Integration is a constant work with sensitive electronics, expensive and unique components. It requires a lot of patience and steadiness while fully understanding of process of assembly.

Confidence should be present in every movement. Otherwise a person should not be allowed to be a part of integration team as it could lead to accidental damage or destruction of spacecraft.

Budget for structure development is shown in Appendix D. It is almost impossible to calculate labor because a lot of people worked and helped at different stages of project progression. Also, timeline of the CXBN-2 project of the last several month is shown in Appendix C.



## 6. REFERENCES

1. *CubeSat Design Specification* (13 Revision) [PDF]. (2014, February 20). The CubeSat Program, California Polytechnic State University. Retrieved from <http://www.cubesat.org/>
2. Grindrod J.L. (2016, November 18). *CXBN-2 Vibration Test Report*. Document number: 161118-CXBN2-VIBTR. Morehead State University, Space Science Center.
3. *NanoRacks CubeSat Deployer (NRCSD) Interface Control Document* (Revision 0.36) [PDF]. (2013, December 10) NanoRacks, LLC. Retrieved from <http://nanoracks.com/>
4. *NanoRacks-NRCSD CubeSat Acceptance and Integration*. (n.d.). Record of Assembly.
5. *NanoRacks-NRCSD CubeSat Vibration Test*. (n.d.). Record of Assembly.
6. *Outgassing Data for Selecting Spacecraft Materials* (2017, March 29). NASA, Goddard Space Flight Center. Database reached at <https://outgassing.nasa.gov/>
7. Ovchinnikov M.Yu., Penkov V.I., Malphrus B.K., Brown K.Z., Roldugin D.S. (2014). *Active magnetic attitude control algorithms for a Cubesat for astrophysics research*. Keldysh Institute Preprints. No. 47. 18 p. URL: <http://library.keldysh.ru/preprint.asp?id=2014-47&lg=e>
8. Pisarenko G.S. (1979). *Strength of Materials*. Kiev: Highest school.
9. *Requirements for Threaded Fastening Systems in Spaceflight Hardware*. (2012 March 12). NASA Technical Standard NASA-STD-5020.
10. Wertz, J., Everett, D. and Puschell, J. (2015). *Space Mission Engineering: The New SMAD*. 1st ed. Hawthorne: Microcosm Press.
11. Yablonski A.A., Nikiforova V.M. (1966). *Course of Theoretical Mechanics*. Moscow: Highest education.

7. APPENDICES

Appendix A: Drawings of structural components

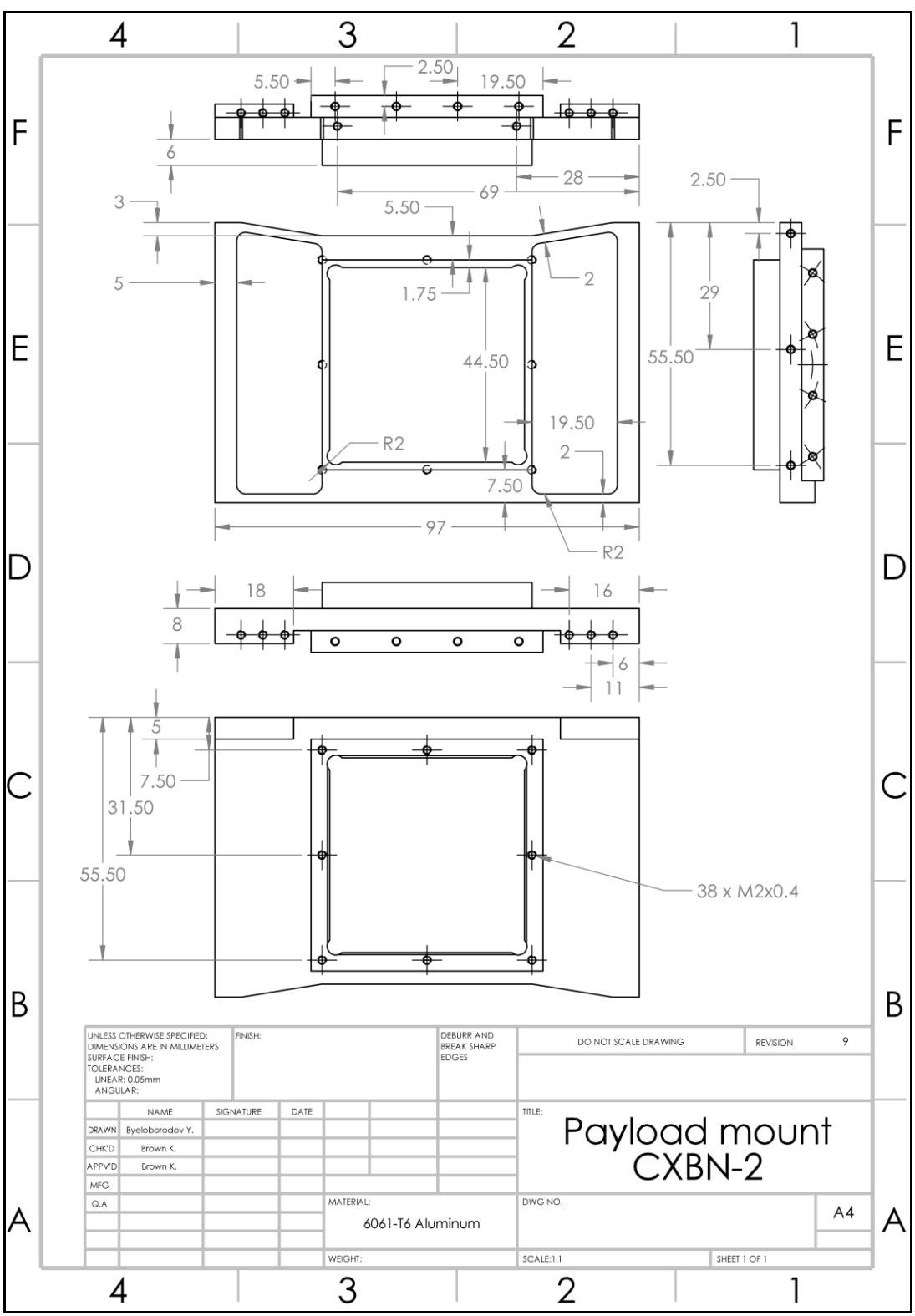

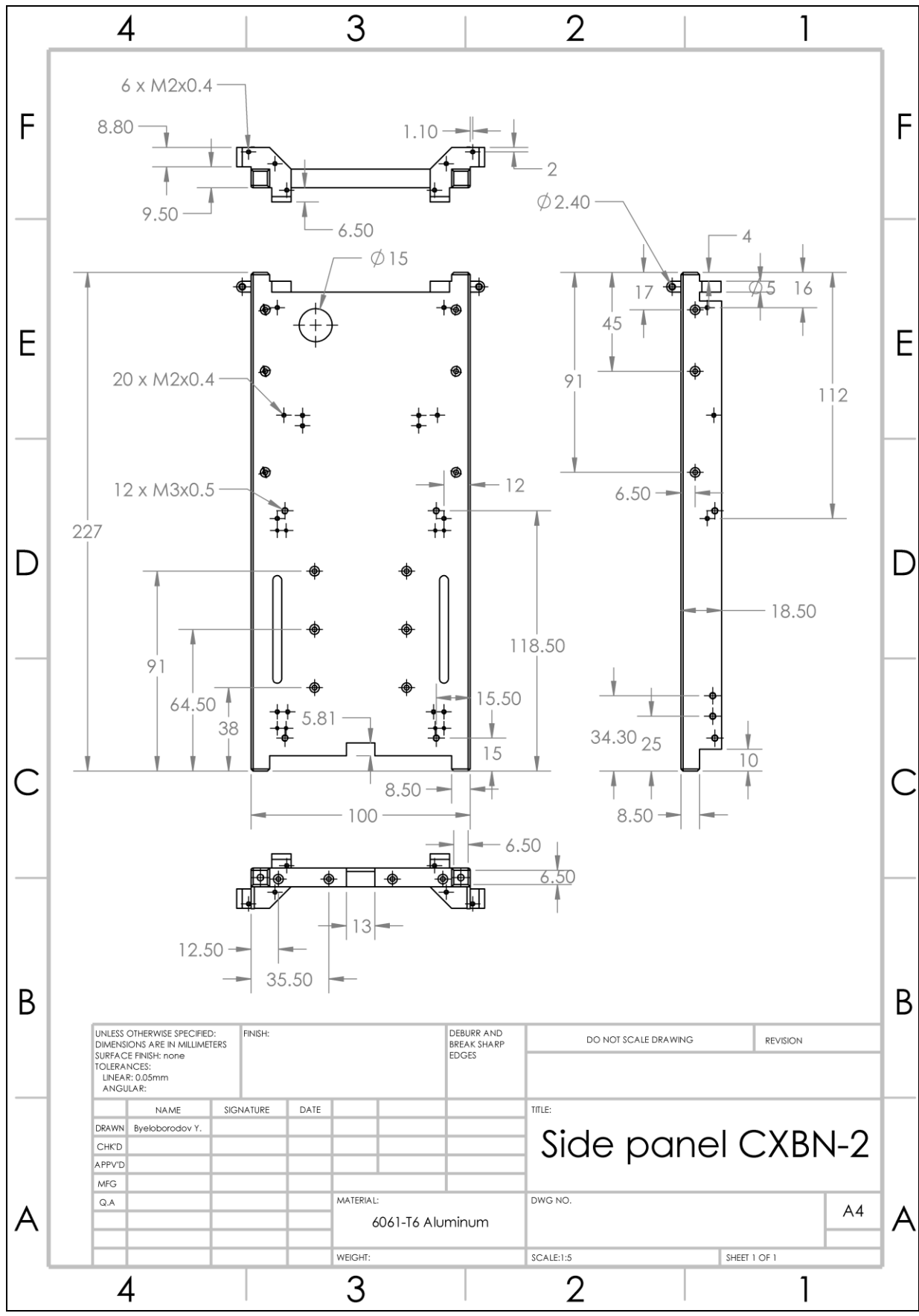

UNLESS OTHERWISE SPECIFIED: DIMENSIONS ARE IN MILLIMETERS SURFACE FINISH: none TOLERANCES: LINEAR: 0.05mm ANGULAR:			FINISH:		DEBURR AND BREAK SHARP EDGES		DO NOT SCALE DRAWING		REVISION		
DRAWN: Byeloborodov Y.			SIGNATURE:		DATE:		TITLE: <b>Side panel CXBN-2</b>				
CHKD:			SIGNATURE:		DATE:		DWG NO.:		A4		
APPVD:			SIGNATURE:		DATE:		MATERIAL: 6061-T6 Aluminum		SCALE: 1:5		
MFG:			SIGNATURE:		DATE:		WEIGHT:		SHEET 1 OF 1		
Q.A:			SIGNATURE:		DATE:						

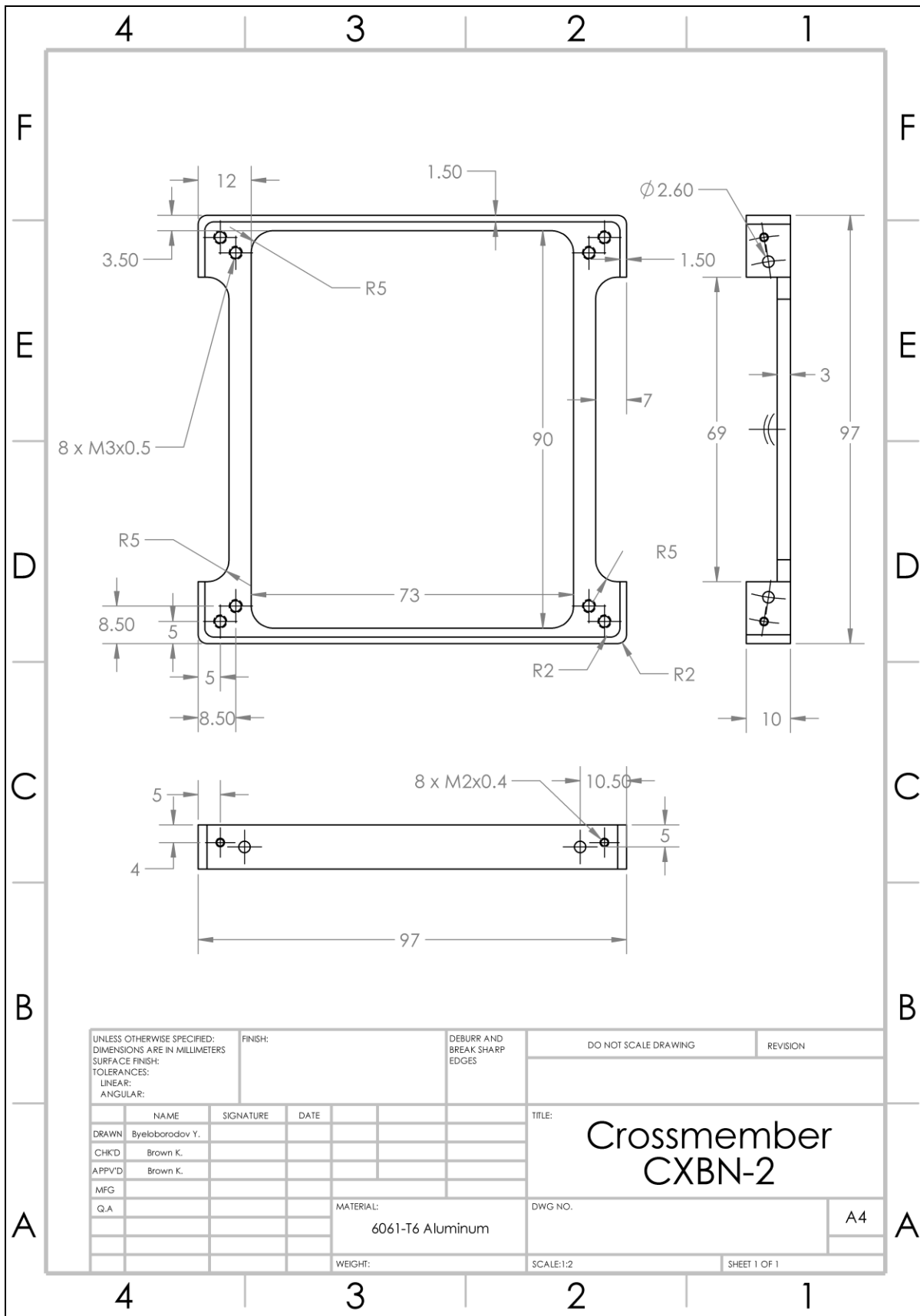

UNLESS OTHERWISE SPECIFIED: DIMENSIONS ARE IN MILLIMETERS			FINISH:		DEBURR AND BREAK SHARP EDGES		DO NOT SCALE DRAWING		REVISION		
SURFACE FINISH:											
TOLERANCES:											
LINEAR:											
ANGULAR:											
NAME		SIGNATURE		DATE		TITLE:					
DRAWN		Byelaborodov Y.				Crossmember CXBN-2					
CHK'D		Brown K.									
APP'V'D		Brown K.									
MFG											
Q.A						MATERIAL:		DWG. NO.		A4	
						6061-T6 Aluminum					
						WEIGHT:		SCALE:1:2		SHEET 1 OF 1	

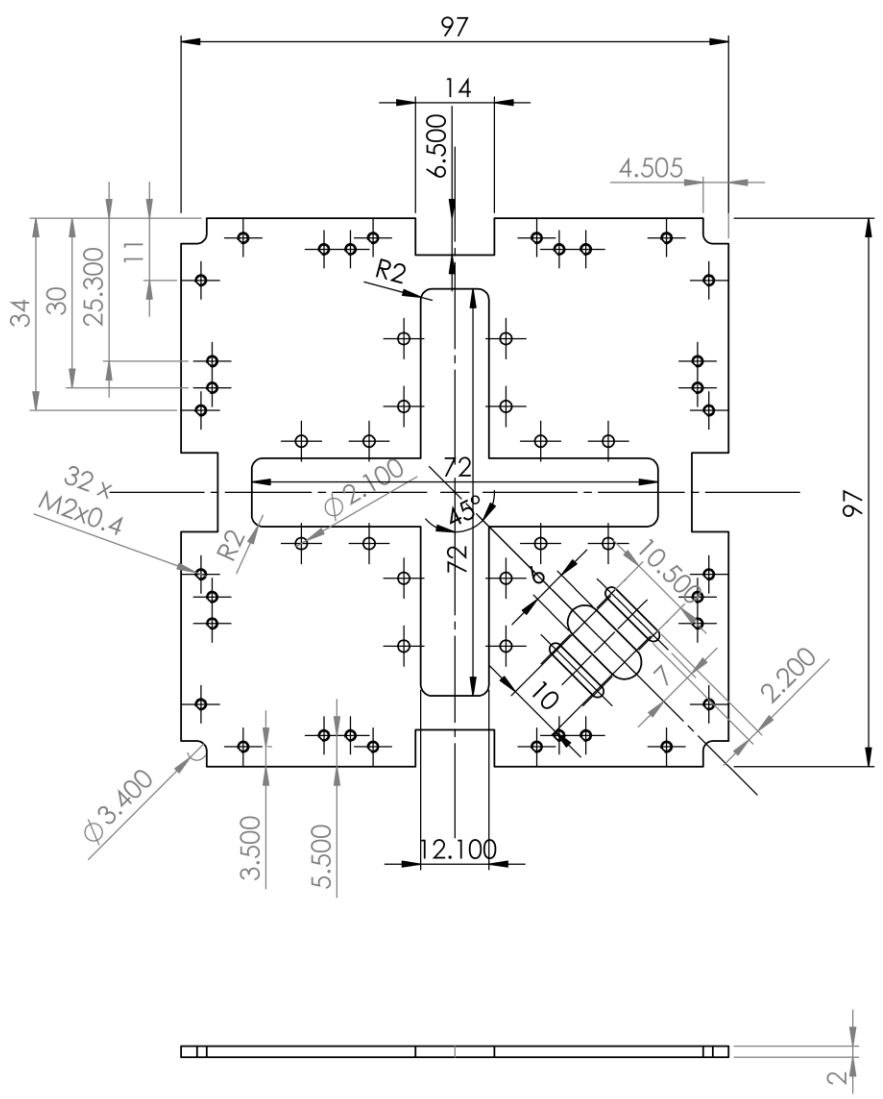

UNLESS OTHERWISE SPECIFIED: DIMENSIONS ARE IN MILLIMETERS SURFACE FINISH: TOLERANCES: LINEAR: 0.05mm ANGULAR:				FINISH:	DEBUR AND BREAK SHARP EDGES	DO NOT SCALE DRAWING	REVISION
DRAWN	NAME	SIGNATURE	DATE			TITLE: <b>Antenna plate CXBN-2</b>	
CHK'D	Byelabarodov Y.						
APPV'D	Brown K.						
MFG							
Q.A					MATERIAL: 6061-T6 Aluminum	DWG NO.	A4
					WEIGHT:	SCALE: 1:2	SHEET 1 OF 1

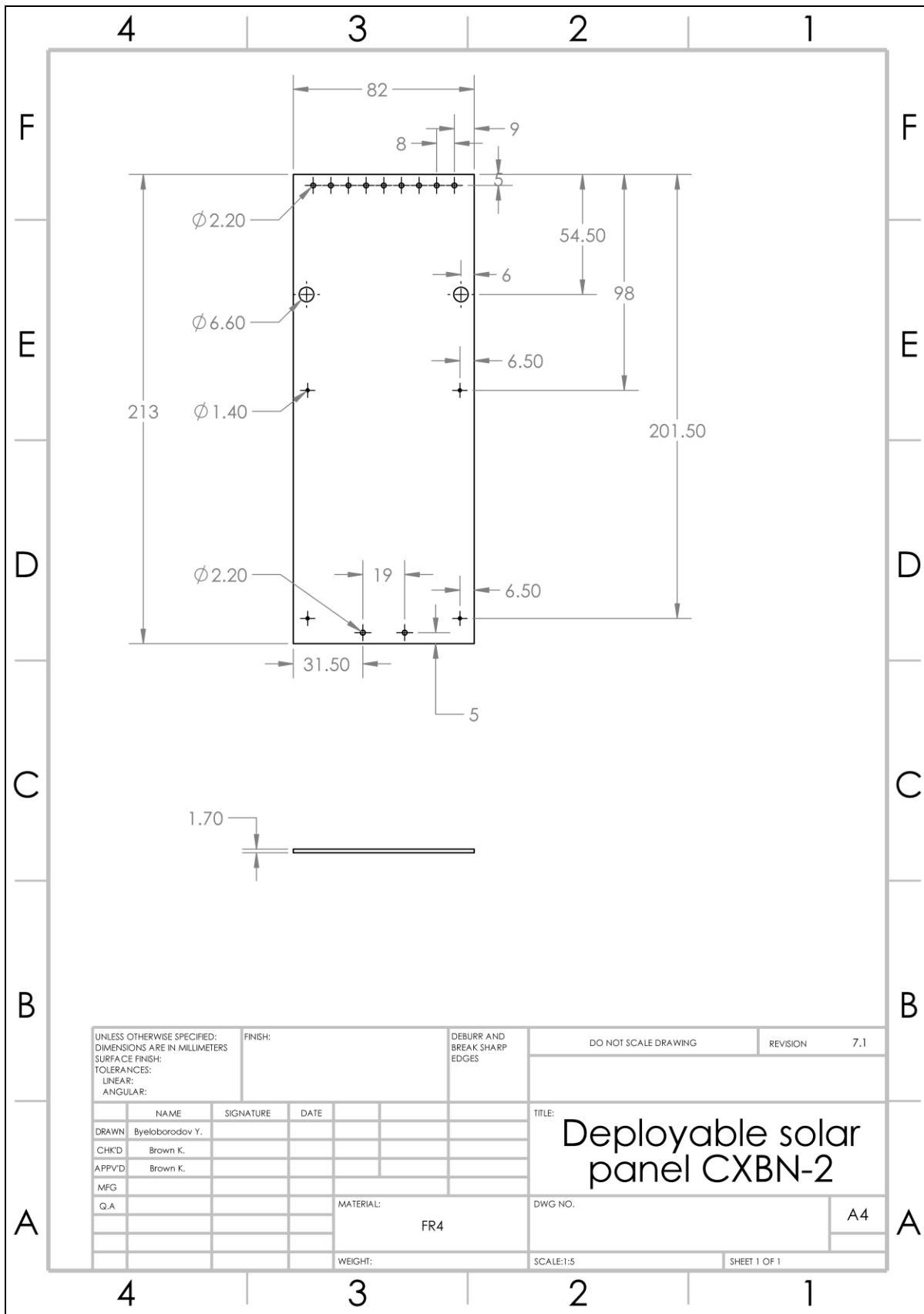

UNLESS OTHERWISE SPECIFIED: DIMENSIONS ARE IN MILLIMETERS SURFACE FINISH: TOLERANCES: LINEAR: ANGULAR:		FINISH:	DEBURR AND BREAK SHARP EDGES		DO NOT SCALE DRAWING	REVISION	7.1
DRAWN		NAME	SIGNATURE	DATE	TITLE: <b>Deployable solar panel CXBN-2</b>		
CHK'D		Brown K.			DWG NO.		
APP'VD		Brown K.			A4		
MFG					MATERIAL: FR4		
Q.A					WEIGHT:		
					SCALE:1:5		
					SHEET 1 OF 1		

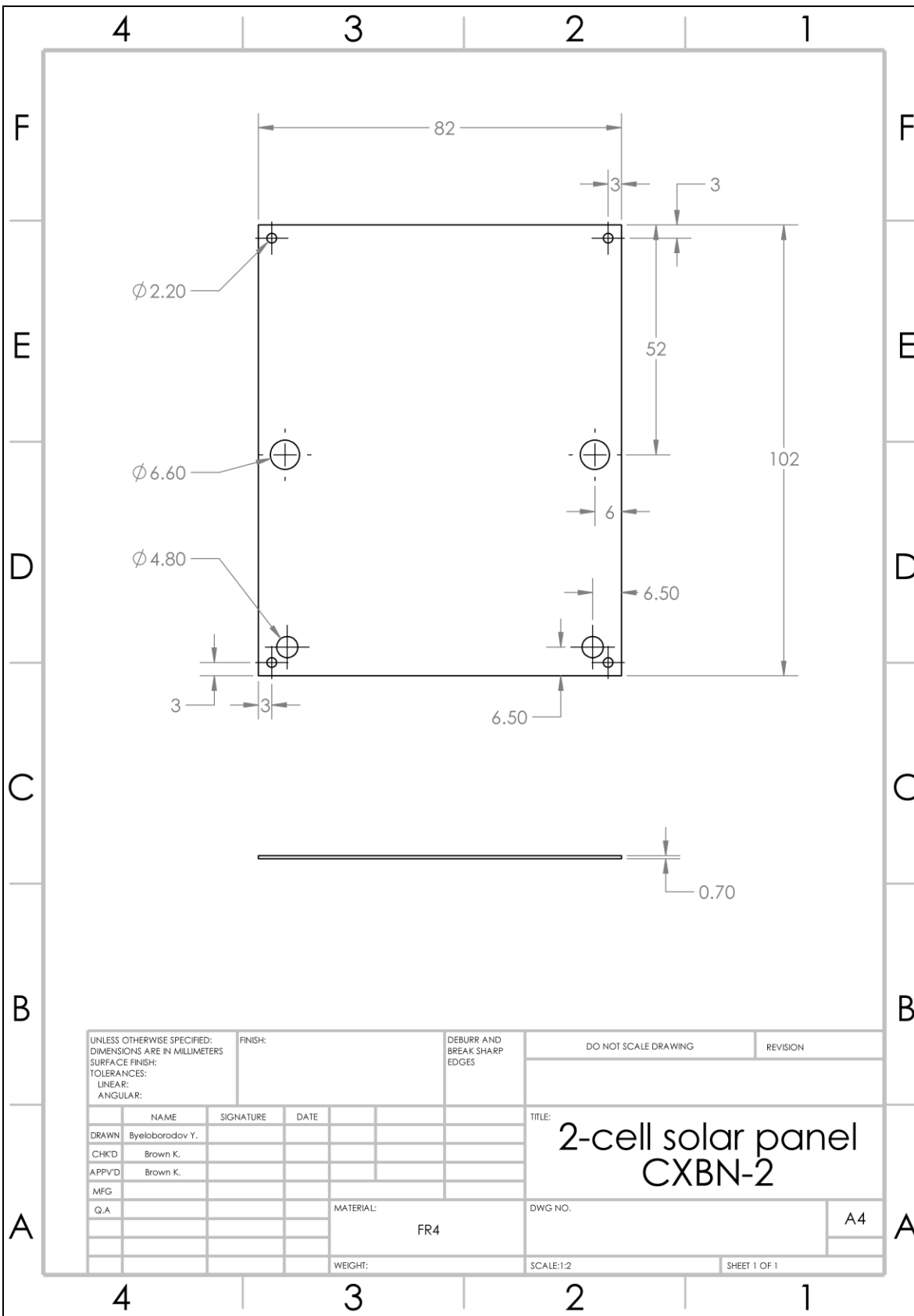

UNLESS OTHERWISE SPECIFIED: DIMENSIONS ARE IN MILLIMETERS SURFACE FINISH: TOLERANCES: LINEAR: ANGULAR:		FINISH:		DEBURR AND BREAK SHARP EDGES		DO NOT SCALE DRAWING		REVISION	
DRAWN: Byelaborodav Y.		SIGNATURE:		DATE:		TITLE: <h2 style="text-align: center;">2-cell solar panel CXBN-2</h2>			
CHKD: Brown K.									
APPV'D: Brown K.									
MFG:									
Q.A:									
				MATERIAL: FR4		DWG. NO.:		A4	
				WEIGHT:		SCALE:1:2		SHEET 1 OF 1	

## Appendix B: List of fasteners

Type	Size	Head Width (mm)	Length (mm)	Amount	Comments	Mass each, grams	Total mass of each type, grams
Flat Head Screw	M2	3.8	4	24	Cross-Member to Side Panel	0.094	2.256
Flat Head Screw	M2	3.8	6	20	SP Limiter + PL to Side Panel	0.13	2.6
Flat Head Screw	M2	3.8	10	8	ACS Z-coil	0.2	1.6
Flat Head Screw	#6-32	6.65	3.175	4	Monofilament	0.335	1.34
Socket Head Cap Screw	M3	5.5	3	2	ADS	0.21	0.42
Socket Head Cap Screw	M3	5.5	4	12	Battery + ACS + EPS	0.63	7.56
Socket Head Cap Screw	M2	3.8	5	24	Lead Shield	0.24	5.76
Socket Head Cap Screw	M2	3.8	7	12	Switch	0.29	3.48
Socket Head Cap Screw	M2.5	4.5	8	12	Batteries	0.5	6
Socket Head Cap Screw	M2	3.8	10	12	ACS XY-coil + Radio	0.34	4.08
Button-Head Socket Cap Screw	M2	3.5	4	34	SP + Wire Cutter	0.137	4.658
Cone Point Set Screws	M3	N/A	3	8	SP Hinge	0.1	0.8
Cone Point Set Screws	M3	N/A	8	16	SP Alignment	0.3	4.8
Pan Head Screws	M2	4	5	24	Antenna Mount	0.2	4.8
Pan Head Screws	M2	4	8	1	RBF Screw	0.25	0.25
Female Threaded Hex Standoff	M2.5	4.5	19	6	Batteries	0.72	4.32
Threaded Spacer	M2.5	4.5	4	4	Payload	0.12	0.48
Unthreaded Spacer	N/A	4.7625	6.35	4	Radio	0.24	0.96
Unthreaded Spacer	N/A	4.5	13	4	C&DH	0.36	1.44
Hex Nut	M2	4	1.2	24	Antenna Mount + XY-coil	0.1	2.4
Female Threaded Round Standoff	M2	4.5	4	8	Payload	0.1	0.8
Self-Clinching Flush Nut	#6-32	6.35	1.5	4	Monofilament	0.068	0.272
		Total	Fasteners:	267	Total mass of fasteners:	61.076	





**Appendix D: Budget**

Machining	\$3,000	3 sets + extra crossmembers
Anodization	\$250	
3D printing collimators	~\$3500	8pcs
Solar panel PCBs	~\$600	
Fasteners and other hardware	~\$1000	
Labor per person	~\$70000	
Total	\$78,350	
Margin +20%	\$94,020	
Total, excluding labor	~\$10000	For 3 fulll sets of structure

## Appendix E: CV

# Yevgeniy Byeloborodov

Mailing address:

235 Martindale Drive  
Morehead, Kentucky, 40351

Phone: (606) 207-0097

Email: yevgeniy.byelob@gmail.com

### **EDUCATION:**

#### **Master of Science in Space Systems Engineering**

Fall 2014 – Present (Expected Graduation: May 2017)

Morehead State University, Morehead KY

Space Science Center, Department of Earth and Space Sciences

#### **Bachelor of Science in Aircraft and Rocket Engineering**

Fall 2010 – Summer 2014

National Technical University of Ukraine “Igor Sikorsky Kyiv Polytechnic Institute”, Kiev, Ukraine

Faculty of Aerospace Systems

### **PROFESSIONAL EXPERIENCE:**

#### **Staff Engineer**

May 15, 2016 - Present

Morehead State University, Space Science Center, Morehead KY

- Development and testing of CubeSat Attitude Determination and Control System
- Analysis and testing of the CXBN-2 satellite structure
- Thermal regulation of the CXBN-2 satellite
- Team lead for the integration and testing (I&T) for the CXBN-2 small satellite mission
- Team lead on Lunar IceCube lunar satellite structural design and analysis

Working at Morehead State University’s Space Science Center as a Staff Engineer is a continuation of my Graduate Research Assistantship. I continue working on most projects that are available, gaining more experience in such fields as thermal management, thermal simulations, structural simulations, extensive use of testing equipment such as Thermo-Vacuum chamber and Shaker Table. Also I gained experience of testing and calibration of the ADCS system of a 2U CubeSat.

Served as team lead for the integration and testing (I&T) for the CXBN-2 small satellite mission, which improved my leadership skills and teamwork experience. This includes algorithmization of satellite assembly, managing tasks within integration team, quality assurance control and improving team work efficiency.

CXBN-2 was selected by NASA through the CubeSat launch initiative and has been launched from Kennedy Space Center on Atlas V in April 18, 2017. Expected deployment into orbit from the International Space Station in June.

Since January 2017 working on development of Lunar IceCube structure which includes 3D CAD modelling, static, vibrational and thermal simulation. Lunar IceCube is a 6U CubeSat that will search for water ice on the surface of the moon. It is one of two secondary payloads NASA selected through the Next Space Technologies for Exploration Partnerships (NextSTEP) Broad Agency Announcement to fly on the first Space Launch System mission.

### **Graduate Research Assistantship**

August 11, 2014 – May 15, 2016

Morehead State University, Department of Earth and Space Science, Morehead, KY

- Student team lead on CubeSat Attitude Determination and Control System
- Structural design development of the CXBN-2 using SolidWorks and Autodesk Inventor
- Nano-satellite systems design
- Nano-satellite Integration and Testing
- Machining shop experience

Morehead State University Space Science Center provides variety of opportunities for students. Here I was able to have an experience working on 2U CubeSat nanosatellite, designing all of the structure and being a team lead on developing Attitude Control and Determination System. While working on this and other projects a lot of design solutions were implemented based on personal experience, with help of partners and usage of available software packages, such as SolidWorks, Autodesk Inventor, Autodesk AutoCAD and Altium. The process of designing and building a spacecraft included hands-on experience with machining equipment.

### **Internship (Summer 2014)**

ANTONOV State Company

- Documentation and drawing revision, editing and creating drawings for AN-148, AN-158
- CAD modeling designing experience using KOMPAS-3D, SolidWorks
- Archive work (finding the right drawings, documentation; revising, scanning, sorting)

ANTONOV is a Ukrainian aircraft manufacturing and services company. It's particular expertise is in the fields of very large aeroplanes and aeroplanes that use unprepared runways.

While having an internship at ANTONOV State Company, I was introduced to the entire aircraft manufacturing process including designing, research, wind tunnel experience, extensive work with technical documentation and solving design issues.

**FLUENT LANGUAGES:**

English, Russian, Ukrainian

**COMPUTER SKILLS:**

- SolidWorks:
  - o Structural analysis
  - o Thermal analysis
- Autodesk AutoCAD
- Autodesk Inventor
- PTC Pro/Engineering
- Altium

**LAB SKILLS:**

- 3D prototyping using 3D-printers
- Machining, metalworking
- Rapid prototyping of spacecraft Fit Check models
- SMD Soldering
- Thermo-Vacuum Chamber operation
- Vibration Table operation
- Helmholtz coils operation
- Sun simulation system operation
- BK Precision 8500

**RELEVANT COURSES:**

**Morehead State University:**

Space Mission Analysis & Design  
Linear Systems  
Spacecraft Design and Fabrication  
Thermal and Structural Analysis  
Advanced Space Communications  
Spacecraft Sensors and Remote Sensing  
Digital Signal Processing  
Modeling and Simulation  
Space Mission Operation

**National Technical University of Ukraine:**

Engineering and Computer-Generated Graphics  
Theoretical Mechanics

Theory of Mechanisms and Machines  
Aircrafts Construction  
Aircrafts Systems  
Aeronautical Material Science  
Material Mechanics and Constructions  
Elements of Aircrafts Construction in CAD, CAM, CAE Systems  
Hydraulics  
Aircraft Aerodynamics  
Applied and Experimental Aerodynamics  
Engineering and Construction of Aircrafts  
Flight Dynamics  
Thermodynamics and Heat Transfer  
Fundamentals of Reliability of Aircrafts and Energy and Propulsion Systems  
Aeronautic and Rocket Engines Construction  
Durability and Resilience of Aircrafts Constructions  
The Process and Technology of Manufacturing Aircrafts and Energy and Propulsion Systems  
Aerohydrodynamics  
The Details of Machinery and Fundamentals of Construction  
Structural Mechanics of Aircrafts and Helicopters

### **PRESENTATIONS:**

- *“Fempto-Satellite Mission Engineering”*, 2nd IAA Conference on University Satellite Missions in Rome, Italy, February 2013.
- *“Determining The Orientation of Satellites Based on Observation of Vectors”*, Thesis, National Technical University of Ukraine, June 2014.
- *“Development of Mechanical Structures of the Cosmic X-Ray Background Nanosatellite –2”*, Kentucky Academy of Science Meeting, November 2014.
- *“Attitude Control and Determination System of Cosmic X-Ray Background Nanosatellite-2”*, Celebration of Student Scholarship at Morehead State University, April 2015.
- *“Development of CubeSat-Compatible Attitude Determination and Control System for The Cosmic X-Ray Background Nanosatellite–2”*, 3rd IAA Conference on University Satellite Missions in Rome, Italy, December 2015

### **HOBBIES/INTERESTS:**

Technology; 3D rapid prototyping and manufacturing; rocketry; propulsion; machining; airplane, automobile, motorcycle restorations and rebuild; hand crafting; antique watch restoration; cycling; photography; modelling; culinary

# Yevgeniy Byeloborodov

Mailing address: 235 Martindale drive,  
Morehead, Kentucky, 40351  
Phone.: (606) 207-0097  
Email: yevgeniy.byelob@gmail.com

---

## References for Yevgeniy Byeloborodov

### **Dr. Benjamin Malphrus**

Project manager, professor, director of Space Science Center at Morehead State University  
Address: 235 Martindale Dr., Morehead, KY, USA  
Phone: (606) 783-2381  
Email: b.malphrus@moreheadstate.edu

### **Robert Twiggs**

Senior Professor of Space Science  
Address: 235 Martindale Dr., Morehead, KY, USA  
Phone: (606) 783-9594  
Email: r.twiggs@moreheadstate.edu

### **Kevin Brown**

Projects lead engineer, space systems engineer  
Address: 235 Martindale Dr., Morehead, KY, USA  
Phone: (408) 373-2756  
Email: kz.brown@moreheadstate.edu