

EVALUATING A PERSONAL STRESS MONITORING  
SYSTEM

Sneha Gogineni

COLUMBUS STATE UNIVERSITY

D. Abbott Turner College of Business and Computer Science

The Graduate Program in Applied Computer Science

**EVALUATING A PERSONAL STRESS MONITORING SYSTEM**

A THESIS SUBMITTED TO

TSYS SCHOOL OF COMPUTER SCIENCE

IN PARTIAL FULFILLMENT OF

THE REQUIREMENTS FOR THE DEGREE OF

MASTER OF SCIENCE

BY

SNEHA GOGINENI

COLUMBUS, GEORGIA

MAY 2017

# EVALUATING A PERSONAL STRESS MONITORING SYSTEM

By

Sneha Gogineni

Committee Chair:

Dr. Wayne Summers

Copyright © 2017 Sneha Gogineni

All Rights Reserved.

Committee Members:

Dr. Lydia Ray

Dr. Alfredo Perez

Dr. Rania Hodhod

Dr. Suk Lee

Columbus State University

May 2017

## ABSTRACT

### EVALUATING A PERSONAL STRESS MONITORING SYSTEM

By

Sneha Gogineni

Committee Chair:

Dr. Wayne Summers

Committee Members:

Dr. Lydia Ray

Dr. Alfredo Perez

Dr. Rania Hodhod

Dr. Suk Lee

Columbus State University

May 2017

Keywords: Affective computing, Emotion, Galvanic Skin Response (GSR) Sensor, Stress Monitoring devices, Tonic skin conductance, Phasic skin conductance.

## ABSTRACT

Now-a-days, Life is generally much more stressful than in the past. "Stress" is the word that we use when we feel that we are overloaded mentally in our thoughts and wonder whether we can really cope with those placed upon us. Sometimes, stress gets us going and they are good for us but at other times, it could be the cause to undermine both our mental and physical health. The way we respond to a challenge can be considered as a kind of stress. Part of our response to a challenge is physiological and affects our own physical state. When we are faced with a challenge or a threat, our body releases some resources to protect us against them - either to get away as fast as we can, or to fight against them. This fight-or-flight response is our body's sympathetic nervous system reacting to a stressful event. During this response, our body produces larger quantities of the chemicals such as cortisol, adrenaline and noradrenaline, which triggers a higher heart rate, heightened muscle preparedness, sweating, and alertness. All these factors help us to protect ourselves in a dangerous or challenging situation. But based on the frequency of stress facing by a person, these changes may affect his or her health negatively. In order to evaluate an individual's stress, I worked on this thesis in developing a personal stress monitoring system to capture the stress undergoing by an individual in his or her daily life.

**Keywords:** Affective computing, Emotions, Stress, Galvanic Skin Response (GSR) Sensor, Stress Monitoring devices, Tonic skin conductance, Phasic skin conductance.

## TABLE OF CONTENTS

ACKNOWLEDGEMENTS .....	v
LIST OF TABLES .....	viii
LIST OF FIGURES .....	ix
CHAPTER 1: INTRODUCTION .....	1
1.1 Problem Statement .....	1
1.2 Affective Computing .....	2
1.3 History of Affective Computing .....	4
1.4 Our Contribution .....	6
1.5 Thesis Organization .....	6
CHAPTER 2: BACKGROUND .....	7
2.1 Introduction .....	7
2.2 Developed Computing Systems .....	8
2.3 Stress Monitoring Systems .....	10
CHAPTER 3: SYSTEM DESCRIPTION .....	15
3.1 Galvanic Skin Response Sensor .....	15
3.2 Arduino Uno .....	16
3.3 BLE Shield 2.1 .....	18
3.4 Mobile application developed .....	19
3.4.1 Functionality of the application.....	19
CHAPTER 4: DISCUSSION OF RESULTS AND CONCLUSION .....	25

4.1 Data analysis on GSR collected data .....	25
4.1.1 PLX-DAQ tool .....	26
4.1.2 Trials done .....	28
4.1.3 Location of the tests performed .....	28
4.2 Processing stages of the system developed.....	43
4.2.1 High level processing stages of the system .....	43
4.2.2 Acquisition diagram .....	44
4.2.3 Circuit diagram .....	44
4.2.4 Device Function .....	45
4.2.5 Processing Stage .....	45
4.3 Advantages .....	46
4.3.1 How this system would be advantageous to improve people's lives...46	
4.4 Limitations of the system .....	46
4.5 Conclusion .....	46
4.6 Future work .....	47
References .....	47

## LIST OF TABLES

Table 1-Affective Computing mechanisms .....	3	16
Table 2: Location of the tests performed.....	28	17
Figure 3: Serial Monitor.....		18
Table 3: Electrical conductance values collected.....	29	
Figure 4: BLE Shield.....		19
Table 4: Average tonic skin conductance calculated for all the users.....	31	
Figure 5: Welcome screen of the app.....		20
Table 5: Average phasic skin conductance calculated for all the users.....	32	
Figure 6: Signup page.....		20
Table 6: Parameters calculated for the activity Stroop test.....	34	
Figure 7: Login page.....		21
Table 7: Parameters calculated for the activity Arithmetic test.....	35	
Figure 8: Status of the Bluetooth.....		21
Figure 9: Bluetooth connect Notification.....		21
Figure 10: Search for nearby devices.....		21
Figure 11: Start button to receive data.....		21
Figure 12: Graph showing the receiving data.....		21
Figure 13: Display stress value and stress level.....		23
Figure 14: History of previous collected data.....		23
Figure 15: Application menu.....		24
Figure 16: Stroop test.....		25
Figure 17: Elevation of the signal when a sudden deep breath is taken.....		27
Figure 18: Normal inhalation of air by User 3.....		27
Figure 19: Sample graph to calculate the parameters.....		33



## LIST OF FIGURES

Figure 1: Galvanic Skin Response Sensor.....	16
Figure 2: Arduino Uno Microcontroller.....	17
Figure 3: Serial Monitor.....	18
Figure 4: BLE Shield.....	19
Figure 5: Welcome screen of the app.....	20
Figure 6: Signup page.....	20
Figure 7: Login page.....	21
Figure 8: Status of the Bluetooth.....	21
Figure 9: Bluetooth connect Notification.....	21
Figure 10: Search for nearby devices.....	21
Figure 11: Start button to receive data.....	22
Figure 12: Graph showing the receiving data.....	22
Figure 13: Display stress value and stress level.....	23
Figure 14: History of previous collected data.....	23
Figure 15: Application menu.....	24
Figure 16. Stroop test.....	25
Figure 17: Elevation of the signal when a sudden deep breath is taken.....	27
Figure 18: Normal inhalation of air by User 3.....	27
Figure 19: Sample graph to calculate the parameters.....	33

Figure 20: Resultant data for combination of both stroop and arithmetic test by User 1.....	37
Figure 21: Current time vs Sensor values for User 2-F.....	38
Figure 22: Current time vs Sensor values for User 3-F.....	38
Figure 23: Current time vs Sensor values for User 4-F.....	39
Figure 24: Current time vs Sensor values for User 36-M.....	39
Figure 25: Current time vs Sensor values for User 20-F.....	40
Figure 26: Current time vs Sensor values for User 12-F.....	40
Figure 27: Current time vs Sensor values for User 25-M.....	41
Figure 28: Current time vs Sensor values for User 40-M.....	41
Figure 29: Current time vs Sensor values for User 40-M.....	42
Figure 30: General diagram.....	43
Figure 31: Acquisition diagram.....	43
Figure 32: Circuit diagram that connects the Arduino to the GSR sensor.....	44
Figure 33: Functionality of the device.....	44
Figure 34: Processing stages.....	45

## Chapter 1. Introduction

### 1.1 Problem Statement

In today's world, Stress has become a major problem affecting many people irrespective of their professions, life situations, age groups and physical health conditions. The Stress in America survey, conducted by Global organization for stress, indicates that 75% of adults reported experiencing moderate to high levels of stress in the past year and 80% of workers feel more stress in their job. It is also noted that stress is a top health concern for U.S. teens between 9<sup>th</sup> and 12<sup>th</sup> grade and psychologists suggest that if they don't learn to manage that stress now, then it could have serious long-term health implications on them (Global Organization for Stress, Stress solutions for the world, 2009).

Moreover, the factors causing stress are leading to a wide range of health problems like low energy, headaches, diarrhea, constipation, nausea, and so on. Not only physical health problems, they also affect an individual mentally by undergoing depression, sleep problems, anxiety, moodiness, irritability, agitation and some other illnesses. People who are working as call center operators, surgeons, social workers or generalists and people in certain phases of their lives are at increased risk of getting overstressed.

Generally, stress is not bad at certain conditions where it helps you to do the work required under some minimum pressure and also encourages you to do the best. But on the other hand, when you face the same stress for a continued period of time, then your body and mind pay the price. There are three different kinds of stress where each one is having its own characteristics, symptoms, duration and medical treatments (Associates, 2014) . Those include acute stress, episodic acute stress and chronic stress.

Acute stress is the most common form of stress that arises from anticipated demands and pressures of the near future. It is thrilling and exciting in small doses. As it is short term, acute stress doesn't have enough time to do the major damage associated with long-term stress. It can crop up in anyone's life, and considered as highly treatable and manageable. Undergoing acute stress too frequently is called as episodic acute stress. People that suffer from this kind of

stress appears to be in a rush and unable to organize themselves with demands and pressures. It can be treated with certain changes in lifestyle but professional help may also be needed before any serious problems develop. Chronic stress is the dangerous kind that makes the person feel depressed, miserable and disheartened on a continual basis. It can be treated with the help of medical professional help such as counselling and behavioral therapy.

The current state of sensor technology allows us to build systems that measure the physical symptoms exhibited by people, thereby reflecting their stress level. The main purpose of this thesis is to develop and evaluate a personal stress monitoring system which can be used in our daily lives. This personal stress monitoring system can be used at our comfortable places like office, home, library, school, etc.

## 1.2 Affective Computing

Affective Computing is one of the types of computing available in today's world. The term "Affective Computing" was first introduced by Rosalind Picard in 1995 where she defined it as "the one that relates to, arises from or deliberately influences emotion or other affective phenomena" (Picard R. , 1997). The main aim of affective computing is that it should be able to recognize the human emotions, convincingly express emotion signals and even possibly have emotions which simulate human-like emotion processes. It mostly strives to bridge the gap between human emotions and computational technology. This field of research is considered as a multi-disciplinary field of research encompassing computer science, engineering, psychology, education, neuroscience and other disciplines.

In other words, we can say that Affective Computing is now used widely to refer to computational modeling of emotions and implementation of autonomous agents capable of affective processing. An affective computing device should possess the ability to detect and respond to its user's emotions and other stimuli accordingly (Rouse, 2006). Such a computing device could collect cues regarding user emotions from a wide variety of sources. For example, some of these sources may include facial expressions, postures, gestures, speech, force or rhythm of keystrokes used and also by using sensors to collect and measure physiological data

such as skin temperature, blood pressure and heartbeat. Following are the affective computing mechanisms used by considering the activities presented below in Table 1.

Table 1-Affective Computing mechanisms

Mechanisms	Activities considered
Facial movement	Facial expressions and its muscle movements
Emotional speech processing	Focused on voice in the activity of talking i.e. determining emotions from spoken words
Biosensors	Heart rate, blood pressure, skin conductivity, pulse rate, body temperature, brain activity, etc.
Robotics	Act like humans which help in automating human activities like pick and place, polishing, machine tending, packaging, quality inspection, etc.
Body gestures	Movement of the skeletal parts of the body
Recognizing emotions on text	Chatting, keystroke pressure and typing speed on the keyboard

Coming to the applications of affective computing, it could offer its benefits in almost a wide range of applications. The more computers we have in our lives, the more we are going to want them to behave politely and be socially smart. We don't want them to bother us with unnecessary information. That kind of common-sense reasoning requires an understanding of our emotional state. A few applications are speech recognition, facial expression detection, e-learning situations, e-therapy which include psychological health services like counseling, learning and pattern recognitions, emotion monitoring agents, affective mirrors, systems that perform with specific predefined functions like recommending a set of videos to fit the changing mood of students and so on (Banafa, 2014). This research explores how affective factors influence interactions between humans and technology, how affect sensing, nothing but emotion sensing (affect = emotion) and more on the design, implementation and evaluation of such systems.

### 1.3 History of Affective Computing

In the time period of 1990's, there was a new focus on the role of emotions in different areas like neurology, psychology, medicine and sociology. It was clear that emotions serve as the basis for rational behavior. Without emotions, it would be hard to survive. Both the body movements and emotion processes are coupled together. In fact, we also know that certain movements will generate emotion processes and vice versa. Emotions are not only the processes that are running in our internal body parts but also an interesting regulatory process over the social setting we are in.

The history of affective computing basically started with the Turing test introduced by R. W. Picard (Picard R. , 1997). The Turing test examines that in a conversation between a human and a computer, the human could not tell the responses generated from a computer are either by a human or by the machine. So, this test is considered as a test of whether or not a machine can "think". In order to pass the test, the computer responses should be in-differentiable from human responses. Even though, the test is designed to communicate only through text, where sensory expressions does not come into play, emotions can still be captured through text and can be explained by its content and structure.

Jocelyn Scheirer and Rosalind W. Picard (Scheirer, 1999) studied on affective communication through the use of "affective objects". Affective objects are physical objects that has the ability to sense the emotional data from a person, map that information to an abstract form of expression and communicate that information expressively either back to the subject i.e. person or to another person. The main issue in building it is how to gain access to the affective content either through physiological sensors, vocal response or facial expression. Physiological signals can be gathered by embedding them into the wearable devices and can collect data about blood pressure, heart rate and skin response. They also introduced Galvactivator (Picard J. S., 2011), a glove that senses and communicates skin conductivity and maps its value to a LED display making the skin conductivity level visible.

Jocelyn Scheirer and Rosalind W. Picard (Picard J. S., 2011) built over 1000 such galvactivators to audience at a daylong symposium. After distributing, they collected and analyzed the brightness levels generated by the device using a video camera focused on the audience. They observed that the brightness increases at the beginning of presentations and during interactive sessions and lower during speeches for a long period of time. They also collected reviews from the audience about their interpersonal uses of the device.

Teresa Marrin and Picard (Marrin, 1999) worked with the Conductor's Jacket to study the emotional expression which relates to musical performance. They used this jacket to gather and analyze the data from a professional conductor in Boston during rehearsals of Prokofiev's Romeo and Juliet Suite No.2. They found that different forms of expressive communication can be measured and detected through physiological signals. Some of them include use of handedness to emphasize musical changes, signaling of upcoming events with sudden changes in effort, the difference between information-bearing and non-information-bearing gestures, the indication of intensity and loudness with changes in muscular force, and the use of breathing to express phrasing in the music. The jacket contained sensors to measure heart rate, respiration, skin conductance, and temperature and muscle tension. They are continuing to validate the results with additional data so that the system will be applicable to both professional conductors and modern, technologically augmented performers using physiological and gesture capture systems.

Dana Kirsch (Kirsch, 1999) introduced Affective Tigger, a toy that responds to the user in a natural and emotive manner. This toy recognizes and reacts to the emotion the child is exhibiting. It was evaluated by assessing the appropriateness of the user responses. They conducted twelve play sessions with the children by inviting them to the MIT Media Laboratory to play with the affective tigger which has its most expressive characteristic as the face. The Affective Tigger's expressive capability is limited to happy, neutral and unhappy.

## 1.4 Our Contribution

Our contribution is to develop and evaluate a personal stress monitoring system using wearable sensors i.e. Galvanic Skin Response sensor and Smartphones. The system is mainly intended to collect the data related to physiological markers for stress in humans via wearable sensors. The stress monitoring system will consist of the following components.

- Galvanic Skin Response (GSR) sensor: Strong emotions can stimulate the human sympathetic nervous system. As a result, sweat glands secrete more sweat as a physiological response to emotional stimuli. The GSR sensor can detect such strong emotions by measuring the electrical conductance of the skin.
- An Arduino microcontroller: A small computer that can collect and analyze the data obtained from the GSR sensor.
- A Bluetooth device: This device can exchange data over short distances with a mobile device.

This thesis work aims at combining all three devices together to build a system that will collect stress markers from humans and will send that data to a smartphone. This work also includes building a smartphone app for collecting and analyzing the data obtained from the system.

## 1.5 Thesis Organization

In the first chapter of this thesis, problem statement, introduction of what an Affective computing is and its history and our contribution to it are outlined in order to better define the research concept. The second part i.e. the second chapter in this thesis provides the background information and importance of emotions in human life and also provides an overview on some of the developed affective computing systems and stress monitoring systems. Chapter three explains the components involved in the personal stress monitoring system development and finally, chapter four discusses the results obtained from data collected through the system and offers recommendations for future work.



## Chapter 2: Background *Computing Systems*

### 2.1 Introduction

A revolution in the science of emotion has emerged in the last few decades, with the potential to induce decision making capability into the systems. Emotions constitute powerful, pervasive and predictable drivers of decision making. In everyday human existence, we conceive of an emotion in a variety of forms like anger, despair, joy, or grief as a feeling, an inner state. The internal experience of emotion is highly personal and confusing as several emotions may be exhibited at the same time (S.Lerner, 2014).

Emotions are considered as a part of human behavior and certain kinds of emotions have an impact on his/her performance. Of course, emotions can even affect a person while taking an intelligent decision. They provide the power to control many aspects of real life unconsciously. Emotions may arise due to many reasons. Some of the reasons may include happiness, sad, joy, stress, disappointment, fear, and tension and so on. An intelligent computer could understand these emotions in the near future based on its own thought processes. Moreover, there are some kind of emotions and feelings that an intelligent agent cannot be able to exhibit. They include hunger, thirst, sickness, dreams, sleepiness, and maternal affection towards their offspring. Research in Affective Computing suggests that the intelligent agents will eventually be able to smell, sense, move, think and speak just like as humans do. Therefore, when a computer tries to follow the human behavior, it should not only possess the ability to think and act but also be able to exhibit emotions. There are also situations where the human machine interaction could be improved by having machines naturally adapt to their users and enables the human-computer interactivity by including emotional communication together with affective information. The following section describes in much detail about some of the intelligent agents that have already been developed.

## 2.2 Developed Affective Computing Systems

To discuss more in detail about the Galvactivator developed by Jocelyn Scheirer and Rosalind W. Picard (Picard J. S., 2011), it consists of a small printed circuit board with analog circuitry that amplifies the skin conductivity signal, and maps it to a super-bright LED. The electrodes are standard nickel-plated clothing snaps and the circuit is powered by two 3V-lithium ion batteries. The board and electrodes are embedded in a neoprene glove that slips over the hand and is secured with a Velcro strap. The board can be easily pulled out to replace the batteries if needed. The back of the glove allows access to a thumb-wheel potentiometer, and contains a star-shaped PVC window which serves to help diffuse the directional beam of the LED. Adjacent to the thumb-wheel is a small jack where the actual signal can be read out and recorded by a computer if desired; however, they designed the glove primarily to be worn without attachment to any other devices.

Elias Vyzas and Picard (Vyzas, 1998) developed a method for recognizing the emotional state of a person who is deliberately expressing one of eight emotions. They measured by using four physiological signals (EMG, BVP, GSR and respiration from chest expansion) and six features of each of these signals were extracted. They used three methods for recognition which are SFFS (Sequential Floating Forward Search) feature selection with K-nearest neighbor's classification, Fisher projection on structured subsets of features with MAP classification and lastly, a hybrid SFFS-Fisher projection method. All the three methods were evaluated on the sets of emotions. The SFFS attained a ratio of 2.7 times than that of random guessing, while the Fisher projection attained a ratio of 3.9 times than the random which is the best performance.

There was another research work performed by Asha Kapur (Asha Kapur, 2005) and some of her colleagues on the concept of "Gesture Based Affective Computing on Motion Capture Data". They used a video-based sensor technology developed by Vicon Motion Systems on monitoring the full skeletal movements of a human body in order to train a machine that identifies different human emotions. The video-based sensor used a series of 6 cameras to capture lightweight markers placed on various points of the body in 3D space and converts the movements into x,y and z displacement data. They focused on collecting four emotions which

are sadness, joy, anger and fear and found that the automatic classification of the collected data ranges from 84% to 92% accuracy depending on how it was calculated.

Affective computing would also be helpful in determining the patient's emotional state in medical care. One of the examples for such kind of AC applications is given by Lisetti C., Nasoz, F., and her research colleagues in (Lisetti C., 2003). As we know that computers and robots are getting introduced into our lives which involve socio-emotional content, there are many such applications that are in development stage. One of them is Tele-Home Health Care (Tele-HHC). This provides a communication between the medical professional and the patient when hands-on care is not necessary. The interventions of this system are used to collect important sign data remotely like ECG, Blood pressure, oxygen saturation, heart beat rate and breath sounds, verify compliance with medicine regimes, improve diet compliance, and assess mental or emotional status. It is therefore important that both the caregiver and care recipient communicate along the affective channel to provide better assessment and responsiveness. The main use of this system is that the patients can be treated and monitored remotely by medical professionals.

MOUE (a Model Of User's Emotions) (Lisetti C., 2003) is also system they developed which builds a model of user's emotions by observing the patient (user) via multi-sensory devices like camera, mouse, keyboard, microphone and a wearable device. It consists of three main components: (1) a sensory apparatus identifying the most likely emotion(s) experienced by the user during human computer interaction; (2) an ontology of emotion concepts representing detailed characteristics of the current emotion; and (3) an active interface which externalizes and adapts to the user the perceived emotional state via a variety of modes depending upon the current context. Moreover, to measure the physiological signals, they used BodyMedia SenseWear, a wireless wearable computer capable of measuring galvanic skin response, skin temperature, ambient temperature, heat flow, and movement. As it is wireless, it can easily and efficiently be used in real time to collect sensory data without disturbing the user. This device focused on eliciting five emotions- neutral, anger, fear, sadness, and frustration. They segmented the data, according to the emotions elicited at corresponding time slots, and then

stored in a three dimensional array. The three dimensions considered are: the subjects who participated in the experiment, the emotion classes and the data signal types (GSR, temperature, and heart rate). They also used two different algorithms to analyze the data stored in the array: (a) the k-Nearest Neighbor Algorithm and (b) the Discriminant Function Analysis, both of which gave similar results while classifying the emotions. Based on the entire empirical readings, they concluded that the current MOUE has to be improved in gathering the baseline data of moderate degree of physiological arousal.

### **2.3 Stress Monitoring Systems**

Now-a-days, Stress is one of the major problems affecting many people from different professions, life situations and age groups. We would definitely say that once in a human lifetime, everyone will undergo some kind of stress at any certain moment of time. But if the influence of the stress undermines a human, then he/she is in trouble thereby experiencing physical or mental illnesses. Basically, there are Stressor and Stress. Stressor is nothing but the agent which/who is causing stress and Stress is a feeling that we face when we are in some kind of pressure. Examples for stressors include work pressure, noise, unpleasant people, job interview, college first day, losing a job, weather events like hurricanes, floods, physical danger and so on. There are both positive and negative stressors in the environment. Positive stressor is the one in which we feel motivated, focuses on our energy, improves our performance, and feels some excitement and some. As we know, Negative stressor is the one which have its impact on our body, especially on our mind. When we face a certain situation which we feel as a challenge, we would work hard towards it and would undergo some kind of stress, having a feel to fight against it. At that time, our body secretes different chemicals like cortisol, adrenaline, norepinephrine which increase our heart rate, sweating, heightened muscle preparedness, alertness and also slows down our immune and digestive systems. So here arises the concept of stress monitoring system which helps you to manage your stress.

From the last decade, there are some sensor technologies introduced into the market which measure the physical symptoms influencing the stress level. Measuring stress continuously throughout our life has become an open challenge. Stress measuring not only helps people in

understand the causes for increment in their stress levels but also prevents the negative outcomes generated by the stress (we can say as chronic stress). Ideally, Stress monitoring systems should be continuous in operation so that it could be able to capture all the responses generated by the people throughout the day. Now we will look at some of those stress monitoring systems available in today's market. For instance, Javier Hernandez (Javier Hernandez, 2014), introduced a pressure sensitive keyboard, report writing provided in short time and a capacitive mouse to observe the difference between stressful and relaxed conditions. For this, they performed an experiment in a laboratory with 24 participants in a 30-minute session. These participants are asked to perform certain activities like expressive writing, text transcription and mouse clicking. During this experiment, participants unknowingly experience certain physiological changes like pupil dilation, intensified heart beating, deeper respiratory breathing and increased muscle tension among many other changes. As the stress in the participants increases significantly, they are more prone to chronic stress which has its effect on health conditions such as depression, hypertension, rise in blood pressure and some forms of cardiovascular diseases.

Javier Hernandez (Javier Hernandez, 2014) used the keyboard as a proxy by examining keyboard dynamics which can provide relevant behavioral information about the effective and cognitive state of the user. In a separate study, Khanna and Sasikumar (Javier Hernandez, 2014) also used keyboard dynamics to distinguish between positive, negative and neutral emotions of 21 participants in a laboratory. They found that the negative emotional state occurrence was mainly due to the typing errors and slower typing speed when compared to the neutral typing speed. In addition to the keyboard dynamics, mouse dynamics also helps in providing important information for stress measurement. Similar to the keyboard dynamics, mouse dynamics also include mouse speed, number of clicks and frequency of movement. One of the major findings while considering mouse dynamics is that higher stress levels yielded increased pressure applied to mouse button as well as more repetitive wrist movements.

Javier Hernandez (Javier Hernandez, 2014) implemented their work by using pressure sensitive keyboard and capacitive mouse with the help of keyboard and mouse dynamics and focused

mostly on pressure. In pressure sensitive keyboard, for each keyboard stroke, the keyboard provides the readings from 0 (no pressure) to 254 (maximum pressure). They implemented a custom made keyboard logger in C++ to gather the readings at a sampling rate of 50Hz. Similarly, the capacitive mouse has a range of 0 (no capacitance) to 15 (maximum capacitance). They also implemented a custom made keyboard logger in C++ which collects the readings at a sampling rate of 120Hz. They have taken two conditions as stressed and relaxed and given some tasks to the participants like text transcription, expressive writing and mouse clicking. From the findings, they noticed that the text transcription captures the type of stress experienced when exposed to a stressful environment and the expressive writing captures a more subjective interpretation of stress commonly experienced when remembering stressful moments. Finally, the mouse clicking task captures the spillover effects of stress from the previous two tasks. They also made the participants use the Q<sup>TM</sup> wrist band sensor to measure the electrodermal activity. The data collected in their experiment varied across participants and they conclude that while developing the stress measurement systems, it is important to keep in mind that stress response is different from person to person and specific models would be preferred.

Javier Hernandez Rivera (Rivera, 2015) also made use of wearable devices to improve the stress measurement. One of the main advantages of wearable devices is that they are in close contact with the body throughout the day which helps in frequent and continuous assessments. To study on this, nine employees at a call center were asked to wear a wrist-worn electrodermal sensor for five days and to report the stress levels associated with each caller. They made a seven point scale to rate the call ranging from "extremely good" to "extremely bad". After categorizing the calls between more stressful calls and low stressful calls, they are able to achieve a recognition accuracy of 78.03% when trained and tested on different days from the same person and 58.45% when trained and tested on different people. Among other wearable devices, they created a custom made Android program that connects Google glass with the Q<sup>TM</sup> sensor through Bluetooth. This enables in continuous assessment and visualization of the captured data. As this is able to collect different physiological parameters wirelessly and

synchronizes with the device automatically, this is critical for the understanding of emotions during natural settings.

Rosalind W. Picard (Sano, 2013) concentrated on finding the physiological or behavioral markers for stress. In their study, they collected five days of data from 18 participants by asking them to use a wrist sensor, mobile phone usage and made surveys. They applied correlation analysis to find the significant features associated with the stress statistically and used machine learning to classify whether the participants were stressed or not. In addition, surveys were filled out every morning and evening. This analysis showed that the high stress level was related to activity level, SMS and screen on/off patterns. They observed that a higher perceived stress scale was correlated with poorer sleep habits with some specific personality characteristics like tendency to be more critical, rude, callous, disorganized, negligent and nervous. They conclude that mobile phone usage and wearable sensor data include features related to stress level.

Akane Sano, Paul Johns and Mary Czerwinski (Akane Sano and Paul Johns, 2015) worked on to develop a feedback-loop, user tailored advice system that helps in providing stress interventions and advices on improving sleep, exercise habits and diet at the work place. They conducted a two week study with 30 participants. In the first week, they collected their behaviors about sleep, diet, exercise and stress levels using Fit bit and surveys. In the second week, they continued to monitor the participants by installing a personalized health advising system ("Health Aware") on their computers art work. This system provided interventions i.e. suggestions and recommendations for stress and it automatically updates the fit bit data from users for every four hours on to the server. Based on their measurements in the previous week, they found that participants with higher stress levels liked more stress interventions and that somatic activities were most preferred and reduced stress levels the most. They observed individual preference differences in the types of advice; however, tracking and receiving advice raised users' awareness of their stress, sleep, exercise, and dietary behaviors. They also found that the largest positive impact was on our participants' dietary behaviors. Overall, more than 50% of participants felt that it was helpful to be made more aware of their stress levels (50%), thought sleep advice was useful (58%), diet advice was useful (73%) and a large number of

participants thought that exercise advice was useful (69%). Akane Sano and his teammates totally worked on this system to study about the physical and emotional health at work place.

### 3.1 Galvanic Skin Response sensor

Jennifer Healey and Rosalind Picard (Jennifer Healey, 1999) worked on smart physiological sensors to embed them in an automobile in order to capture the naturally occurring episodes of driver stress. They mainly focused on how pattern recognition techniques can be applied to identify the best combination of features to detect automobile driver's stress and used electrocardiogram, electromyogram, respiration and skin conductance sensors to measure the autonomic nervous system activation. The signals generated from these sensors were digitized in real time and stored on the SmartCar's Pentium class computer with video cameras, a microphone and four physiological sensors. Each drive followed a pre-specified route through fifteen different routes from which four stress level categories were developed based on the results of the subjects self-report questionnaires. A Linear discriminant function was used to rank each feature individually based on recognition performance and sequential forward floating selection algorithm. They observed that by detecting patterns across combinations of features, performance of recognizing stress in drivers improves from at best 62.2% to 88.6%. However, the recognition rates from this experiment suggested that stress information could be used by a computer to control non-critical driving applications like music selection, managing cell phones and GPS.



## Chapter 3: System Description

### 3.1 Galvanic Skin Response sensor

Galvanic Skin Response Sensor, shortly called as GSR sensor, is one of the most popular devices to measure the emotional arousal. Galvanic Skin Response is also called as Skin Conductance or Electrodermal activity. For most of the people, it is probably best known for being the tech we find inside a 'lie detector' test. But in real life, there is much more to know about the GSR methodology. "The Skin tells everything" (Platform, 2015). Generally, our skin gives us a lot of information on how we feel when we are exposed to certain kind of pictures, videos, events, etc. – which could be either positive or negative. The resulting action would be a change in the electrical conductivity of our skin. The GSR sensor captures those changes in the electrical conductivity which is generally large, varies slowly over time and fluctuates quickly during physical and emotional arousals. It is because of these arousal states, where the galvanic skin response originates.

The Galvanic Skin Response emerges from the autonomic activation of sweat glands in the skin. Basically, the amounts of sweat glands vary across the human body, being highest in hand and foot regions. When these sweat glands become more active, they secrete moisture through pores directed towards the skin surface. As this result in the balance change of positive and negative ions in the secreted fluid, electrical current flows more easily and thereby resulting in measurable changes in skin conductance. This change in skin conductance is generally termed as Galvanic Skin Response (GSR) (Platform, 2015). The higher arousal, either positive or negative, results in higher skin conductance. The collected GSR sensor data shows some distinctive patterns that can be seen easily and quantified statistically.

Emotional sweating is different from regular sweating. We cannot control the sweat secretion consciously. It is controlled and balanced by our autonomic nervous system to meet our behavioral needs. This is where we can differentiate from regular sweating. In simple words, we can say that the sweat secretion and its associated changes in skin conductance are non-conscious processes that are under sympathetic control and therefore reflect changes in

arousal (Platform, 2015). Emotional experiences trigger changes in autonomic arousal quite impressively. Exposure to fear-inducing stimuli such as an angry face, the sight of a creepy spider, etc. induces emotional arousal, causing an increase in sweat secretion and obviously measurable electrodermal activity. Therefore, GSR sensor is considered as the best in helping us to tap into information about our current physiological and psychological state. Following is a sample picture of how a GSR sensor looks like.

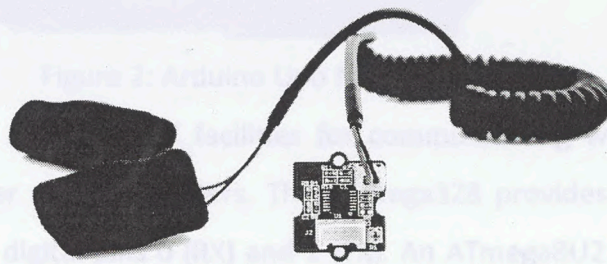

Figure 1: Galvanic Skin Response Sensor

Discussing about the working of GSR, it consists of two electrodes which can be mounted onto the fingers. A conductive gel can be used in order to improve the conductivity between the skin and electrodes. Its measurement is relatively simple and has a good repeatability in the readings acquired. It serves as a useful tool in examining the autonomous nervous system functions.

### 3.2 Arduino Uno

Talking in detail about the Arduino Uno, it is the microcontroller board based on the ATmega328. We can say that this microcontroller is the heart of this developed system. It operates at a voltage of 5-12volts and limits up to 20v. It consists of 14 digital input/output pins of which 6 are PWM (Pulse Width Modulation), 6 analog inputs, a USB connection, a power jack and a reset button. We can make use of it by simply connecting it to a computer with a USB cable or with an external power supply. The ATmega328 consists of 32kb of flash memory in

order to store the code where 0.5kb is used for the boot loader. Following Figure 2 is the picture of the Arduino Uno.

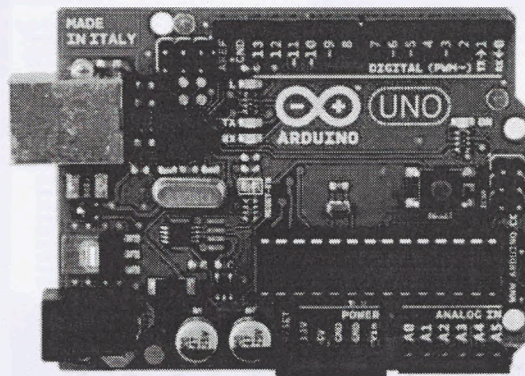

Figure 2: Arduino Uno Microcontroller

This microcontroller has a number of facilities for communicating with either a computer, another Arduino, or other microcontrollers. The ATmega328 provides serial communication, which is available on the digital pins 0 (RX) and 1 (TX). An ATmega8U2 on the board channels this serial communication over USB and appears as a virtual com port to software on the computer. It also uses the standard USB COM drivers, and no external driver is further needed. The Arduino software also includes a serial monitor that allows simple textual data to be sent to and from the Arduino board. The RX and TX LEDs on the board will flash when data is being transmitted via the USB-to serial chip and USB connection to the computer, thereby letting us know that the data is being transit. The main reason behind using this microcontroller is because of its easy and fast prototyping. It gives you a lot of free code libraries that allows you to concentrate more on testing your idea rather than on building supporting circuitry (Products, n.d.).

feature for Arduino boards including UNO, Mega 2560, Leonardo and Due. This device can exchange data over short distances with a mobile device. It also allows us to connect Arduino boards with other central devices such as a tablet or a smartphone. This shield could operate at a voltage of under 3.3v or 5v. There are some certain smartphones OS versions that this device is compatible with like iOS 7 or 8, Android 4.3 or above with built in Bluetooth 4.0 hardware support, windows 8.1, Mac OS 10.9.2 and Linux with BlueZ 5.1 (RedBearlab.com, n.d.).

With the help of this shield, we can develop some applications like:

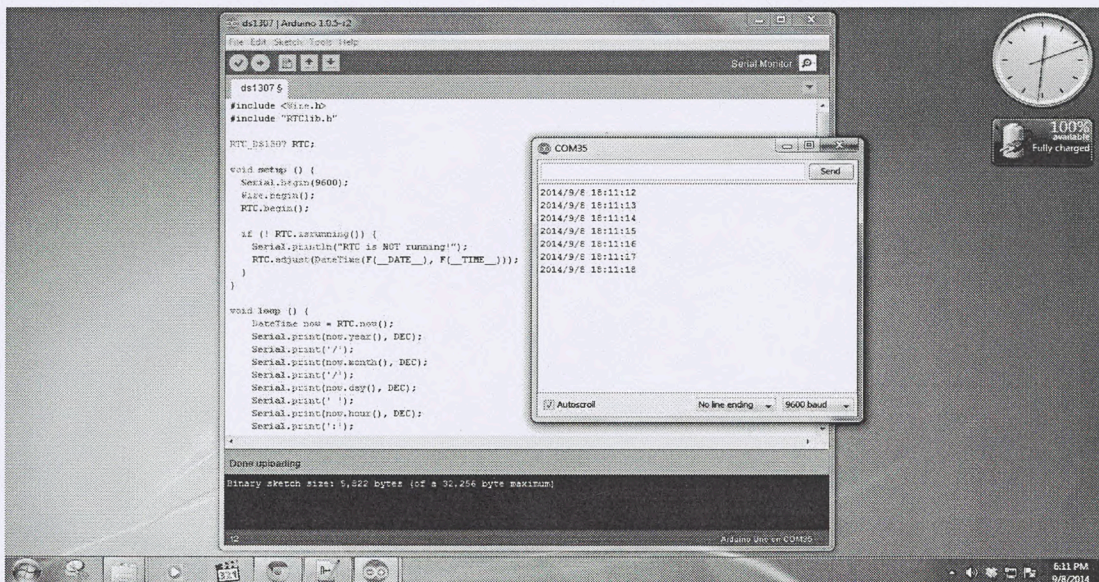

Figure 3: Serial Monitor (Wickramasinghe, 2015)

The Arduino Uno can be programmed with the Arduino software which we can be downloaded at <https://www.arduino.cc/en/Main/Software>. When the board is connected to either a computer running Mac OS X or Linux or Windows, it resets each time a connection is made to it from software through USB. For the following half-second or so, the boot loader is running on the Uno. As Arduino is a cross-platform program, it can sense the environment by taking input from a wide variety of sensors and can affect its surroundings by controlling lights, motors and other actuators (Products, n.d.).

### 3.3 BLE Shield 2.1

BLE Shield is an Arduino compatible shield with nRF8001 BLE controller chip embedded in it. The BLE controller chip enables BLE (Bluetooth Low Energy) feature for Arduino boards including UNO, Mega 2560, Leonardo and Due. This device can exchange data over short distances with a mobile device. It also allows us to connect Arduino boards with other BLE central devices such as a tablet or a smartphone. This shield could operate at a voltage of under 3.3v or 5v. There are some certain smartphone OS versions that this device is compatible with like iOS 7 or 8, Android 4.3 or above with built in Bluetooth 4.0 hardware support, windows 8.1, Mac OS 10.9.2 and Linux with BlueZ 5.1 (Redbearlab.com, n.d.).

With the help of this shield, we can develop some applications like:

- Controlling Arduino pins with our own mobile App i.e. can be done through the Red Bear shield mobile app available in the Appstore or Play store.
- Sending sensor data from Arduino board to a mobile app for processing.
- Using mobile device as an Internet gateway for your Arduino and much more.

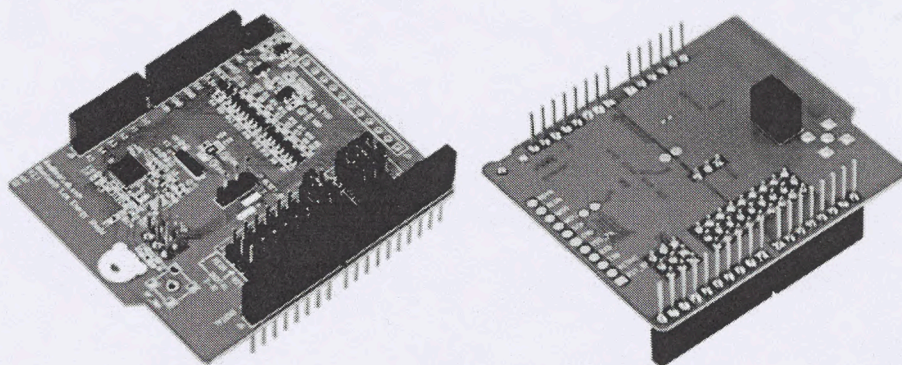

Figure 4: BLE Shield (Redbearlab.com, n.d.)

Similar to Arduino Uno, we need to install the BLE SDK in order to use the shield for BLE Applications. There is a software library called nRF8001 library, BLE Shield library that allows Arduino board to control the BLE Shield and offers a simple TX/RX service for exchanging data between nRF8001 BLE device and central devices such as smartphones. In this thesis, the Arduino board is acting as the Master device and smartphone used is acting as a peripheral device.

### 3.4 Mobile App developed

In this thesis, we have developed a mobile app that receives the data from the Arduino board through the BLE Shield. Based on the data collected for a minute, the app displays the stress level of the user which is categorized as high, medium and low. The ranges of each category is included so that based on the average value calculated for a minute, the app will yield the final average value and the appropriate stress level.

#### 3.4.1 Functionality of the application

When we start the application on a smartphone, the first page will display two buttons "Signup" and "Login". "Signup" is for new users who want to create an account and "Login" is

for users who already have an account and would like to sign in. When the user chooses to create a new account by clicking on “Signup” button, it will ask for some user information such as username, password, first name, last name, gender and date of birth as shown in Figure 6. Once the required information is provided, the user would be able to “Signup”. Once we are logged in to the application, a Bluetooth status page will be displayed where we can pair the device with the application as in Figure 8.

Following are the step-by-step processes to monitor our stress level with some screenshots.



Figure 5: Welcome screen of the app

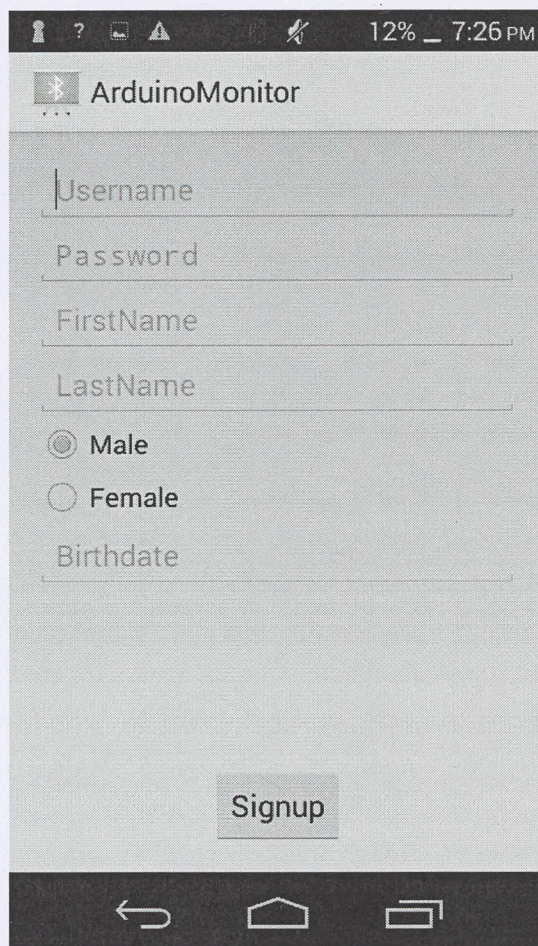

Figure 6: Signup page

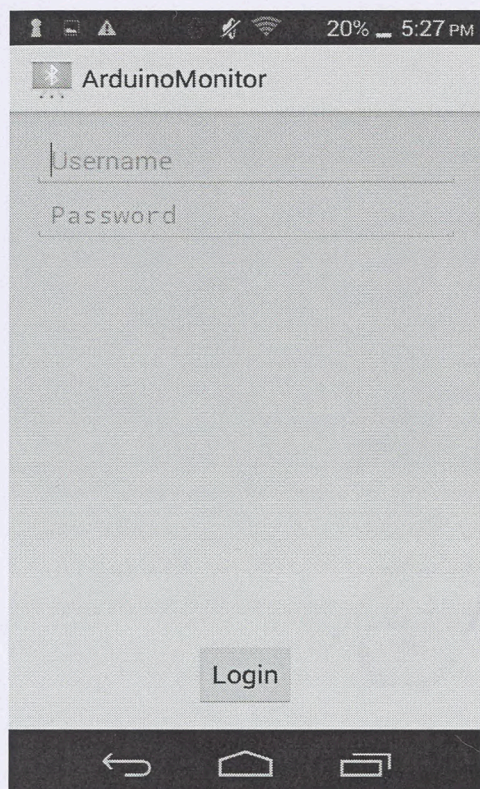

Figure 7: Login page

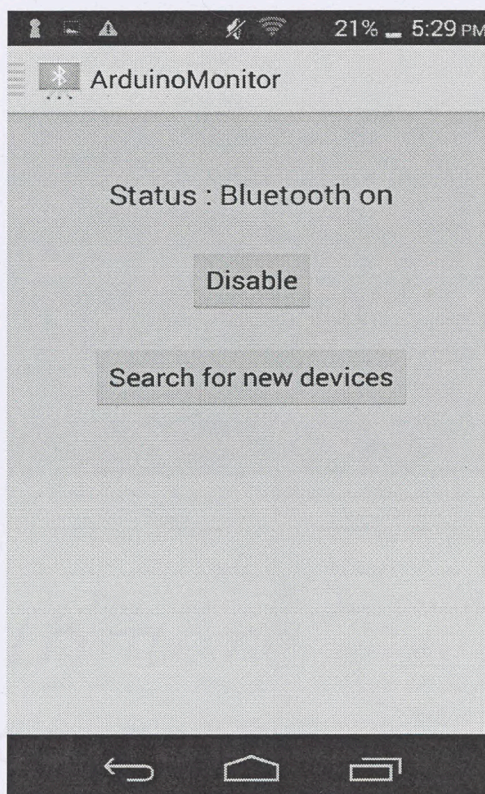

Figure 8: Status of the Bluetooth

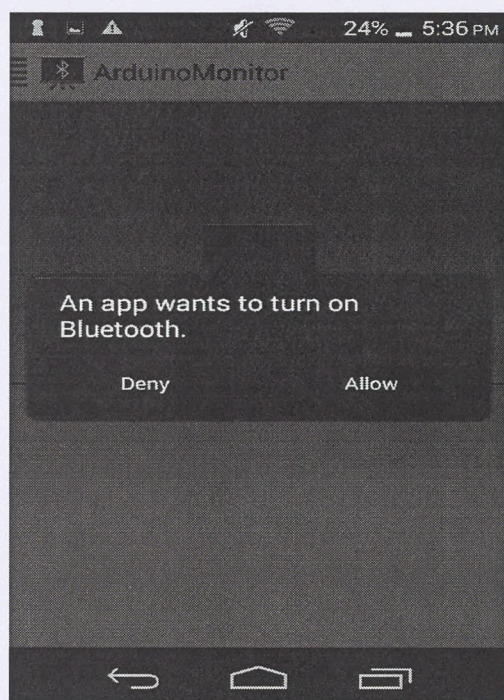

Figure 9: Bluetooth connect notification

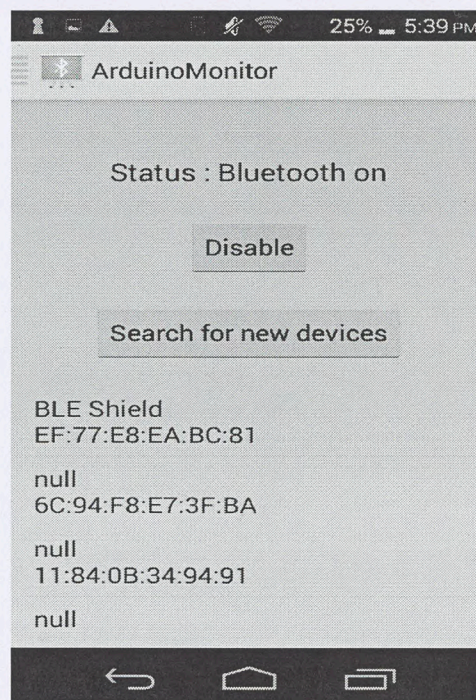

Figure 10: Search for nearby devices

Once the user login into the application, an interface with Bluetooth status will be displayed on the screen showing whether the Bluetooth is enabled or disabled. If you want to disable the Bluetooth, we can do so by clicking on the disable button. If the Bluetooth is already disabled on the device, we can turn it on by clicking on the enable button which requests the user to turn the Bluetooth as shown in Figure 9. We can even search for any new devices that we want to make a connection by clicking "Search for new devices" displayed in Figure 10. If the Bluetooth is in the enabled state, we get a list of devices displayed under the disable button and we have to connect to the BLE Shield in order to receive the data.

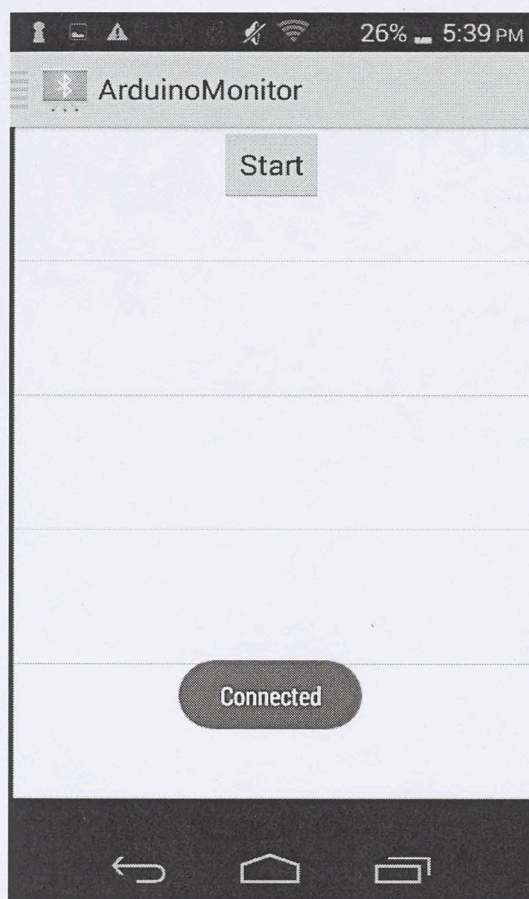

Figure 11: Start button to receive data

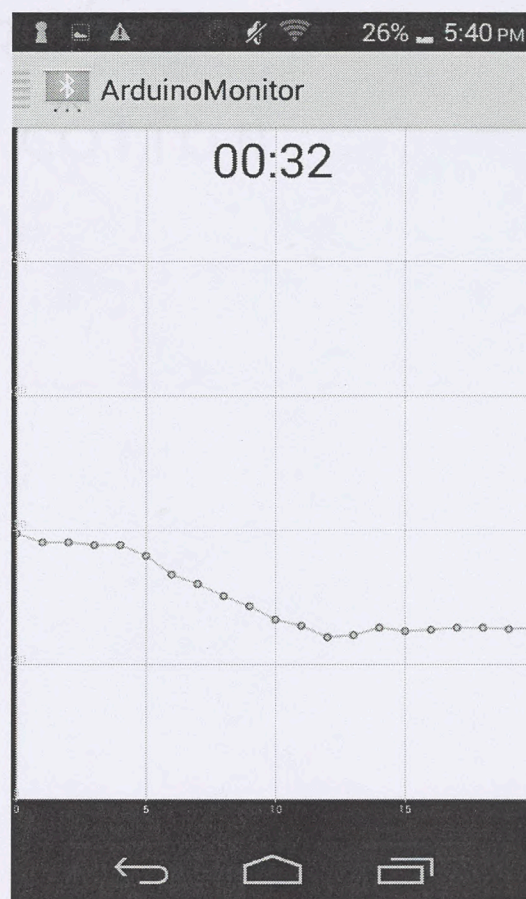

Figure 12: Graph showing the receiving data

Once the BLE Shield is connected to the application, a notification will be displayed with "connected" status on the next page, where a start button is also displayed to start receiving the data. The data will be received once the GSR sensor is mounted to the fingers and displayed



in a graphical format or it would show a constant line indicating that the GSR sensor is not mounted to the fingers as shown in Figure 12.

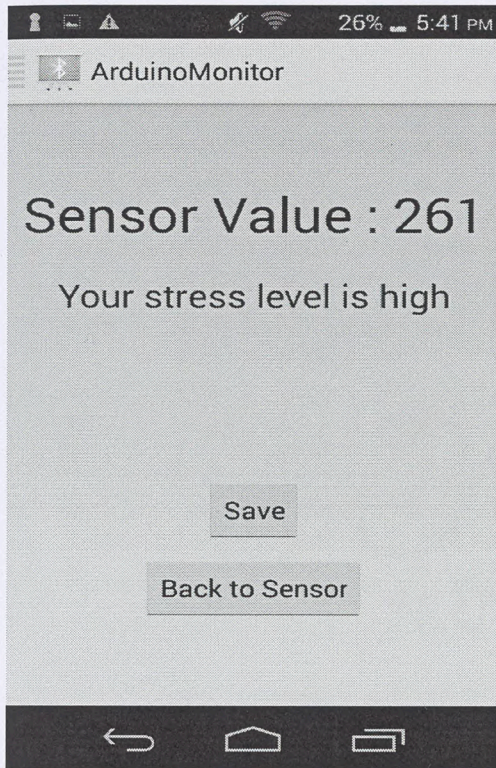

Figure 13: Displaying the sensor value and Stress level

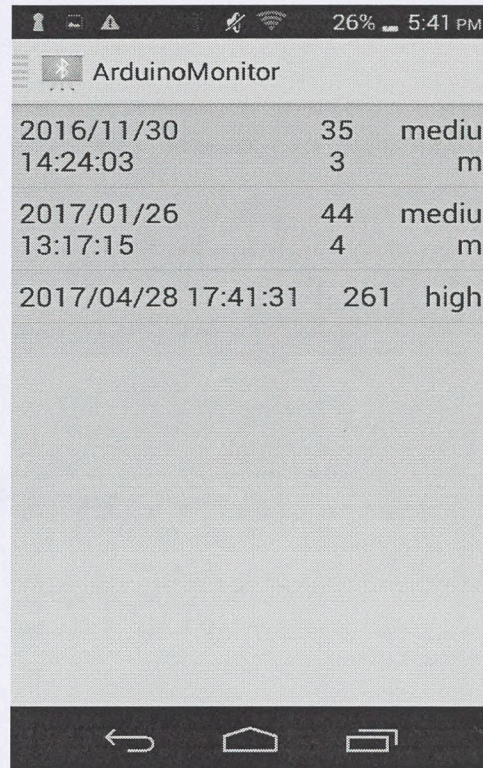

Figure 14: History of previous collected data

The data will be collected for a minute from the sensor where countdown starts from 60 and redirects to an interface which will display the sensor value and the associated stress level for the data collected. We can save the record by clicking on save button which redirects to the history page in the menu of the application consisting of the previous recorded values.

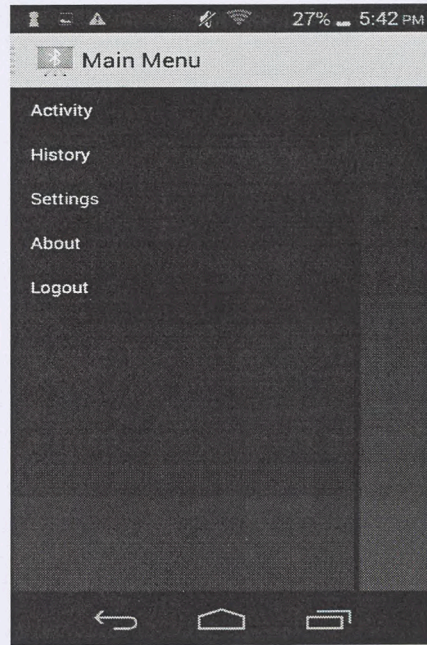

Figure 15: Application Menu

## Chapter 4: Discussion of Results and Conclusion

### 4.1 Data analysis on GSR collected data

In this thesis work, I used the GSR sensor to collect the data from subjects i.e. individuals aged between 20 and 30 by giving two different kinds of activities. One is a Stroop test and the other one is an arithmetic test. I have collected data from up to 40 adults from which 20 are male and 20 are female. Firstly, the real impedance of the skin is measured without performing any activity for a minute. Secondly, a Stroop test that requires the subject to name colors of each word without reading the words is given for a minute (a picture of Stroop test is included below) and finally an arithmetic test for one more minute i.e. subtract the number 13 from a 4-digit number and then again subtract 13 from the resulting number and so on. Changes in the activities performed can be identified in the continuous data stream found in the Arduino's serial monitor.

BROWN	RED	BLUE	BLUE	RED
RED	PURPLE	GREEN	ORANGE	GREEN
ORANGE	BROWN	PURPLE	GREEN	PURPLE
GREEN	BLUE	ORANGE	BROWN	ORANGE
BLUE	ORANGE	RED	RED	BROWN
PURPLE	BROWN	BLUE	BLUE	GREEN
RED	PURPLE	BROWN	PURPLE	RED
GREEN	BLUE	BLUE	BROWN	PURPLE
BROWN	RED	RED	ORANGE	BLUE
ORANGE	BROWN	ORANGE	BLUE	GREEN
PURPLE	GREEN	PURPLE	BROWN	ORANGE
GREEN	ORANGE	GREEN	PURPLE	RED

Figure 16: Stroop test

### 4.1.1 PLX-DAQ Tool

In order to export the data from Arduino' serial monitor, I have used Parallax Data Acquisition tool (PLX-DAQ). This tool helps us to import the extracted data into a Microsoft Excel Sheet where I have performed data analysis. It acquires up to 26 channels of data from any parallax microcontrollers and drops the numbers into columns as they arrive. It helps in providing an easy spreadsheet analysis of data collected in either the fields, laboratory analysis of sensors or real-time equipment monitoring.

Any of the microcontrollers connected to any kind of sensor and the serial port available on a PC can now send data directly into the Excel sheets.

#### Features:

- Plots data as it arrives in real time using MS-Excel
- Records up to 26 columns of data
- Marks data with real time as hh:mm:ss
- Baud rates up to 128k
- Supports com ports ranging from 1 to 15

As the data is collected from Arduino to MS Excel through PLX-DAQ, we have generated some graphs to consider regarding the sensor wave forms. We can see a steep incline to a distinctive peak and also a slow decline to a baseline level.

Let us see the graph for signal elevation of a user who has performed a sudden deep breath (inhalation) in a minute. In the Figure User 31-F indicates that user is 31<sup>st</sup> User and a female. This indication works for all other graphs too.

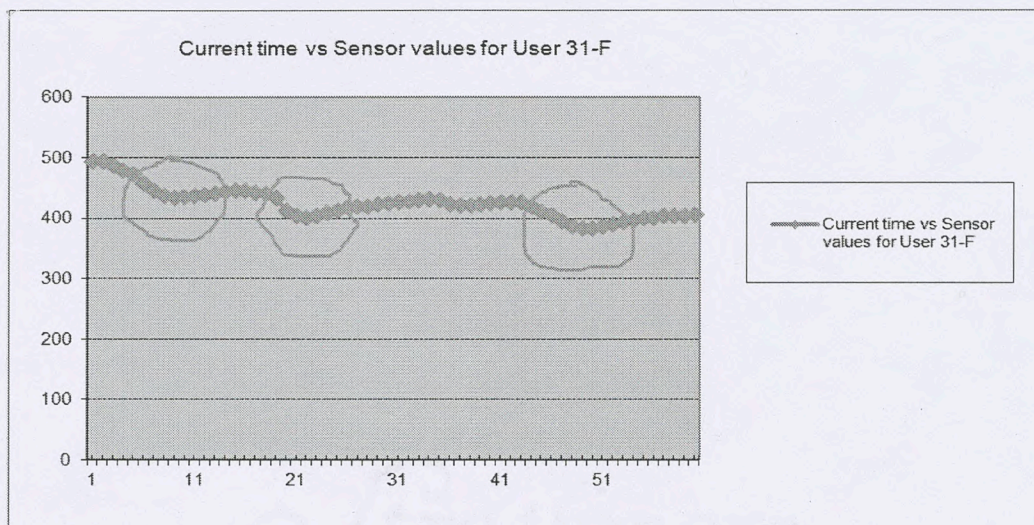

Figure 17: Elevation of the signal when a sudden deep breath is taken

By seeing at the above graph, I have considered the time in seconds for a minute on x-axis and sensor values ranging from 0 to 600 on y-axis. Based upon the data collected, while the user is performing a sudden deep inhalations and exhalations in her breath, we can see some declinations in the stream at certain points of time pointed out in the graph. When analyzing the GSR data, we need to focus mainly on the event related high's and low's as they can be interpreted as direct measures of arousal and engagement of the subjects. Let us also see a graph where a user performs no activity except a regular breathing for a minute.

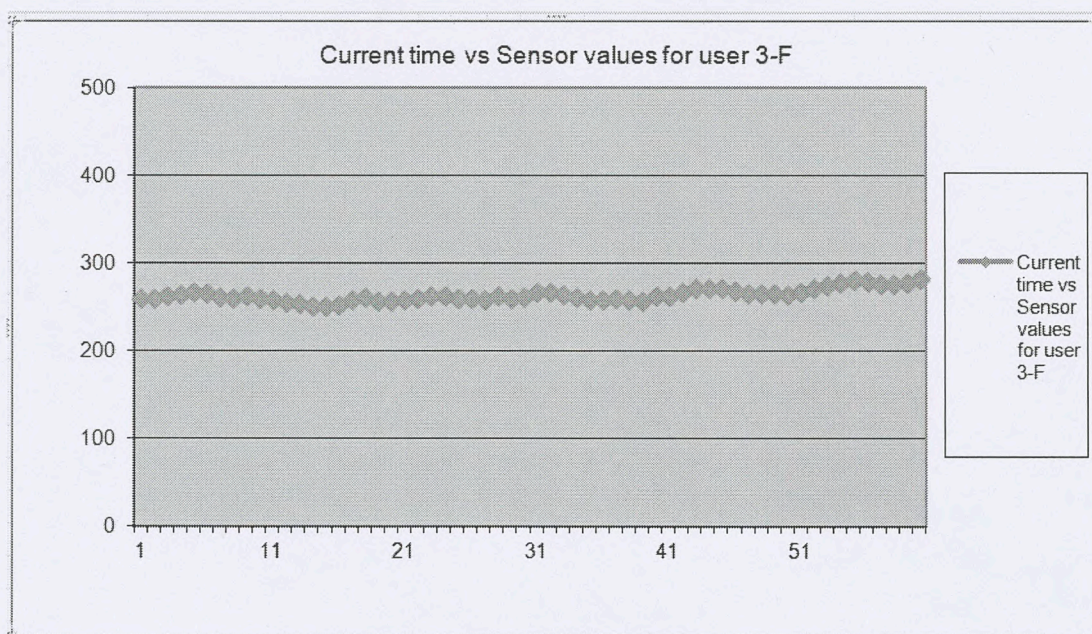

Figure 18: Normal inhalation of air by User 3

This one does not show any major elevations in the data stream line as there is no activity performed by the user. I will explain in detail regarding the graphs created for other users as well.

#### **4.1.2 Trials done**

Three kinds of tests were conducted majorly in order to verify the behavior of the GSR device.

- Stroop test
- Arithmetic test
- No activity i.e. feeling relaxed
- Sudden deep Inhaling and exhaling

#### **4.1.3 Location of the tests performed**

The table below shows the places where the different studies took place. The studies have been made at the subject's work and home locations as GSR sensor is intended to work in daily situations.

Table 2: Location of the tests performed

User 1	Home	User 21	Library
User 2	Home	User 22	Home
User 3	Home	User 23	Library
User 4	Library	User 24	Home
User 5	Home	User 25	Home
User 6	Library	User 26	Home
User 7	Library	User 27	Library
User 8	Home	User 28	Library
User 9	Library	User 29	Home
User 10	Home	User 30	Home
User 11	Home	User 31	Library
User 12	Home	User 32	Home

User 13	Home	User 33	Library
User 14	Library	User 34	Library
User 15	Library	User 35	Library
User 16	Home	User 36	Home
User 17	Library	User 37	Home
User 18	Library	User 38	Home
User 19	Home	User 39	Library
User 20	Home	User 40	Home

Different values of the electrical conductance collected:

Table 3: Electrical conductance values collected

250	254
192	215
258	315
328	421
482	485
345	367
590	610
321	226

We know that EDRs (Electrodermal Responses) are changes in the electrical properties of an individual's skin which are caused by an interaction between the environmental events and an individual's psychological state. And also, as human skin is a good conductor of electricity and when a small amount of voltage say 5V is applied to the skin, changes in the skin's conduction of that signal can be measured. The variable that is measured would be either skin resistance or its reciprocal called, skin conductance.

According to Ohm's law,

Skin resistance (R) is equal to the voltage (V) applied between two electrodes on the fingers divided by the current passed through the skin (I). This can be expressed as

$$R = V/I$$

The GSR sensor used in this project, applies a constant potential to the skin through the two electrodes. As previously mentioned, the voltage is too small i.e. 5V that it could not be felt or understood by the subject. So whenever the voltage is applied, the current that flows through the skin can be detected and displayed either in the form of a graph or in numerical values. As the constant voltage applied is already known and the current flow can be measured, the skin's conductance can be determined.

In general, there are two types of skin conductance which are tonic and phasic (Chong L. LimaU, 1996). Tonic skin conductance is the one which is considered as the baseline level of skin conductance. It is the skin conductance recorded when there is no activity performed by the subject or in the absence of any particular discrete environmental events. This tonic skin conductance is referred as Skin Conductance Level (SCL) which varies from person to person in general. SCLs also vary over time in subjects depending on his or her psychological state and autonomic nervous system regulation.

Coming to the phasic skin conductance, this is the one that changes when an activity is performed by the subject or when some events taken place between the environment and individual's psychological state. Discrete environmental events may include sights, sounds, smells, etc. and could evoke time related changes in skin conductance. This is referred to as the Skin Conductance Responses (SCRs). SCRs increases while there is an increase in the conductance of the skin which may last up to 10-20 seconds followed by a return to the tonic skin conductance. These phasic changes are simply called as GSRs. Subjects show GSRs spontaneously which are not event related to varying degrees. Some persons are highly reactive with considerable spontaneous generation of GSRs and others have a relatively steady tonic level of skin conductance without spontaneous GSRs.



**Average tonic skin conductance calculated for all the users:**

Table 4: Average tonic skin conductance calculated for all the users

Users	Average Tonic Skin Conductance	Users	Average Tonic Skin Conductance
User 1	259.03	User 21	668.43
User 2	278.16	User 22	435.85
User 3	263.63	User 23	362.53
User 4	430.93	User 24	645.30
User 5	574.60	User 25	660.91
User 6	289.48	User 26	542.01
User 7	580.95	User 27	385.20
User 8	316.16	User 28	489.83
User 9	257.75	User 29	477.06
User 10	444.15	User 30	332.59
User 11	282.06	User 31	425.13
User 12	277.16	User 32	590.67
User 13	519.96	User 33	491.05
User 14	419.91	User 34	579.95
User 15	252.16	User 35	303.06
User 16	515.06	User 36	206.08
User 17	474.05	User 37	273.58
User 18	436.38	User 38	519.36
User 19	288.11	User 39	368.21
User 20	592.08	User 40	375.60

**Average phasic skin conductance calculated for all the users:**

Table 5: Average phasic skin conductance calculated for all the users

Users	Average Phasic Skin Conductance	Users	Average Phasic Skin Conductance
User 1	257.45	User 21	660.60
User 2	255.50	User 22	472.07
User 3	288.56	User 23	436.74
User 4	423.56	User 24	641.28
User 5	565.83	User 25	268.52
User 6	277.45	User 26	471.86
User 7	561.59	User 27	372.05
User 8	296.40	User 28	485.00
User 9	254.82	User 29	474.43
User 10	433.08	User 30	282.95
User 11	282.75	User 31	407.68
User 12	229.94	User 32	528.99
User 13	501.43	User 33	444.58
User 14	406.82	User 34	568.43
User 15	231.22	User 35	200.16
User 16	478.70	User 36	140.79
User 17	425.06	User 37	241.27
User 18	385.98	User 38	481.37
User 19	308.00	User 39	412.15
User 20	595.26	User 40	397.94

There are some features of event-related GSRs that can be quantified. Some of them are amplitude, latency, rise time and half-recovery time in seconds. These features can be determined from a graph displayed below (Dr Jason J Braithwaite, 2013).

- **Amplitude:** This is the difference between the tonic skin conductance level at the time the response was raised and the skin conductance at the peak of the response.
- **Latency:** It is the time between the stimulus and the onset of the event-related GSR; latency values should be about three seconds or less.
- **Rise time:** It is the time between the onset of the event-related GSR and the peak of the response;
- **Half-recovery time:** It is the time between the peak of the response and the point after the peak when the conductance returns to an amplitude that is one-half the amplitude of the peak; typical values for half-recovery time are two to ten seconds (Inc., 2013).

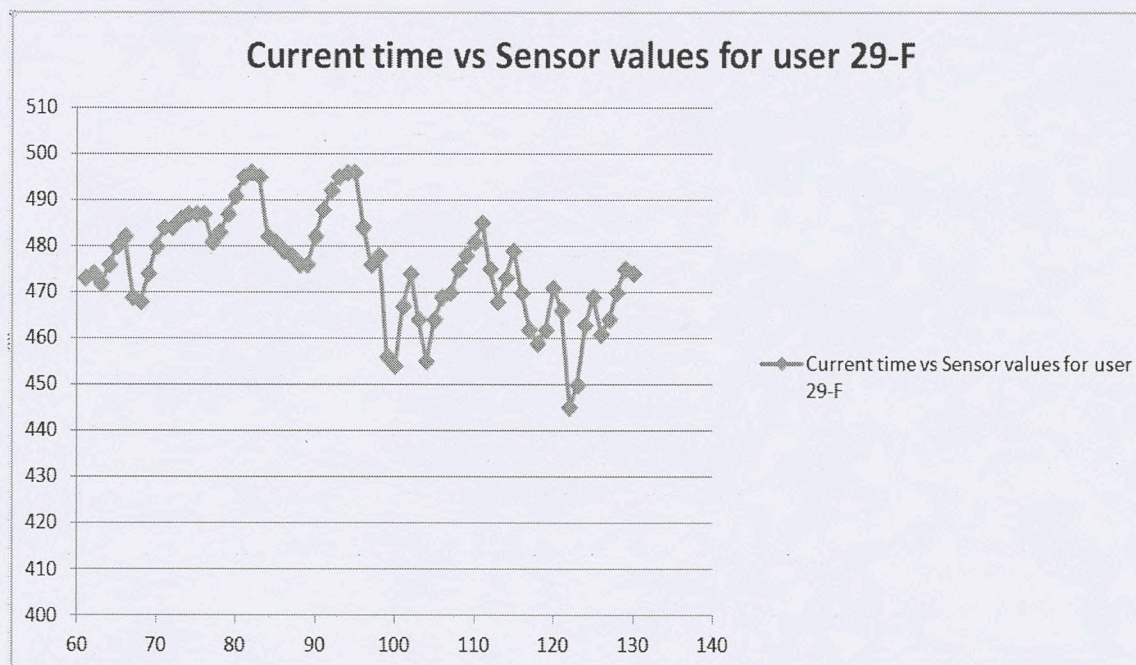

Figure 19: Sample graph to calculate the parameters

In the graph presented above, the user was asked to perform the stroop test. The parameters mentioned above are measured from the subject's recording include

- A tonic skin conductance level of 476.91.
- A latency of the phasic GSR in response to the stroop test activity of 2 seconds.
- Amplitude of the phasic GSR of 23m.

- A rise time of the phasic GSR of 1second.
- A half-recovery time of 2 seconds.

Similarly, based on the activity i.e. Stroop test performed by all the subjects, I created the below table with respect to all the rest of the users.

Table 6: Parameters calculated for the activity Stroop test

Subjects	SCL	Latency of phasic GSR	Amplitude	Rise time	Half-recovery time
User 1	261	1 sec	9m	1 sec	2 sec
User 2	243	2 sec	48m	1 sec	12sec
User 3	278	2 sec	7m	10 sec	10 sec
User 4	419	1 sec	12m	19 sec	10 sec
User 5	568	1 sec	-	1 sec	2 sec
User 6	289	1 sec	13m	14 sec	8 sec
User 7	579	1 sec	2m	5 sec	3 sec
User 8	320	1 sec	5m	6 sec	3 sec
User 9	242	1 sec	32m	48 sec	16 sec
User 10	438	1 sec	5m	4 sec	2.5 sec
User 11	285	1 sec	14m	19 sec	7 sec
User 12	258	1 sec	2m	2 sec	1 sec
User 13	535	1 sec	11m	30 sec	5.5 sec
User 14	422	2 sec	18m	34 sec	9 sec
User 15	192	1 sec	53m	26 sec	26.5 sec
User 16	496	2 sec	20m	15 sec	10 sec
User 17	439	1 sec	8m	15 sec	4 sec
User 18	419	1 sec	7m	13 sec	3.5 sec
User 19	304	1 sec	27m	20 sec	13.5 sec
User 20	593	1 sec	4m	5 sec	2 sec

User 21	665	1 sec	-	3 sec	-
User 22	444	1 sec	46m	16 sec	23 sec
User 23	365	1 sec	113m	24 sec	56.5 sec
User 24	645	1 sec	-	1 sec	-
User 25	617	1 sec	-	1 sec	-
User 26	487	1 sec	2m	3 sec	1 sec
User 27	368	1 sec	31m	16 sec	15.5 sec
User 28	499	1 sec	7m	6 sec	3.5 sec
User 29	468	2 sec	23m	20 sec	11.5 sec
User 30	308	1 sec	14m	7 sec	7 sec
User 31	406	1 sec	11m	28 sec	5.5 sec
User 32	552	1 sec	10m	22 sec	5 sec
User 33	471	1 sec	2m	16 sec	1 sec
User 34	576	1 sec	-	1 sec	-
User 35	288	1 sec	2m	1 sec	1 sec
User 36	197	1 sec	2m	2 sec	1 sec
User 37	282	1 sec	1m	2 sec	1 sec
User 38	488	1 sec	-	1 sec	-
User 39	325	2 sec	99m	21 sec	45 sec
User 40	399	1 sec	14m	21 sec	7 sec

Moreover, I also created a table similar to the above one based on the arithmetic test activity performed by all the subjects.

Table 7: Parameters calculated for the activity Arithmetic test

Subjects	SCL	Latency	Amplitude	Rise time	Half-recovery time
User 1	271	1 sec	4m	4 sec	2 sec
User 2	242	1 sec	35m	9 sec	17.5 sec
User 3	293	1 sec	13m	14 sec	6.5 sec

User 4	424	1 sec	16m	12 sec	8 sec
User 5	568	1 sec	-	1 sec	2 sec
User 6	289	1 sec	13m	14 sec	8 sec
User 7	553	2 sec	12m	10 sec	6 sec
User 8	278	2 sec	43m	20 sec	21.5 sec
User 9	245	2 sec	33m	18 sec	16.5 sec
User 10	438	1 sec	5m	4 sec	2.5 sec
User 11	271	2 sec	24m	14 sec	12 sec
User 12	243	1 sec	-	-	-
User 13	485	1 sec	1m	10 sec	1 sec
User 14	376	1 sec	53m	11 sec	26.5 sec
User 15	247	2 sec	2m	2 sec	1 sec
User 16	487	1 sec	8m	8 sec	4 sec
User 17	433	1 sec	5m	4 sec	2.5 sec
User 18	371	1 sec	4m	4 sec	2 sec
User 19	285	2 sec	65m	21sec	32.5 sec
User 20	593	1 sec	4m	5 sec	2 sec
User 21	657	1 sec	-	1 sec	-
User 22	477	2 sec	1m	1 sec	0.5 sec
User 23	435	1 sec	44m	8 sec	22 sec
User 24	644	1 sec	-	1 sec	-
User 25	201	1 sec	11m	4 sec	5.5 sec
User 26	458	2 sec	32m	4 sec	16 sec
User 27	393	1 sec	4m	5 sec	2 sec
User 28	499	1 sec	7m	6 sec	3.5 sec
User 29	471	2 sec	10m	8 sec	5 sec
User 30	282	1 sec	7m	16 sec	3.5sec
User 31	419	1 sec	5m	13 sec	2.5 sec

User 32	515	1 sec	20m	14 sec	10 sec
User 33	446	1 sec	5m	14 sec	2.5 sec
User 34	568	1 sec	-	-	-
User 35	187	2 sec	16m	10 sec	8 sec
User 36	126	1 sec	18m	7 sec	9 sec
User 37	231	2 sec	9m	16 sec	4.5 sec
User 38	486	1 sec	1m	1 sec	0.5 sec
User 39	429	1 sec	45m	26 sec	22.5 sec
User 40	385	1 sec	72m	26 sec	36 sec

Based on the statistics mentioned in the above tables, “-“ indicates that there is no amplitude i.e. there is no rise in the level of sensor data collected.

Moreover, following are some of the answers to situations related to Stroop test and arithmetic test.

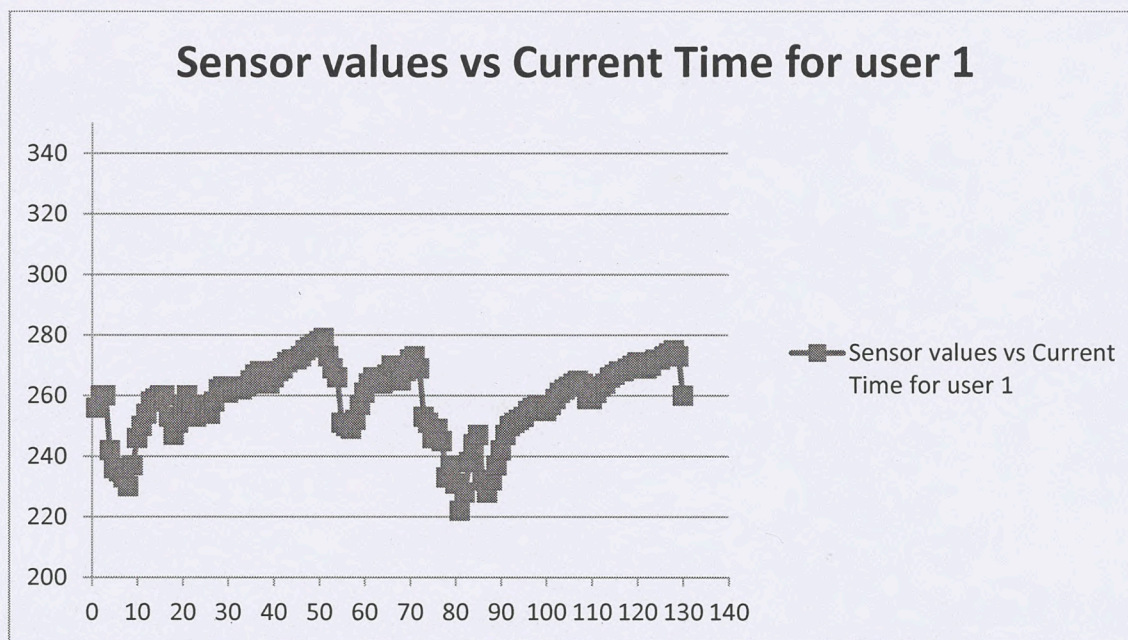

Figure 20: Resultant data for combination of both Stroop and arithmetic test by User 1-F

From the data collected for User 1-F, the user exhibited different variations in the data stream ranging from the baseline to the peak level and then returning to a level considered below the

baseline and again raising to the peak level. These variations determine the arousal affects that the user is undergoing while performing both the activities.

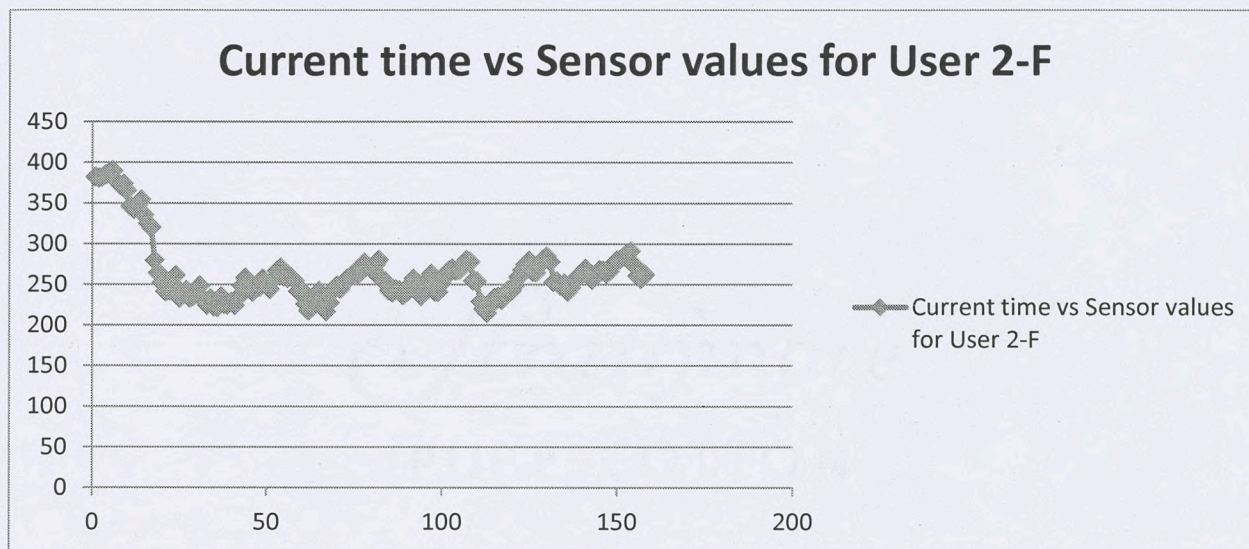

Figure 21: Current time vs Sensor values for User 2-F

By seeing at the above graph, we find that the user's phasic skin conductance level is getting down the graph and went through some variations in the level generated.

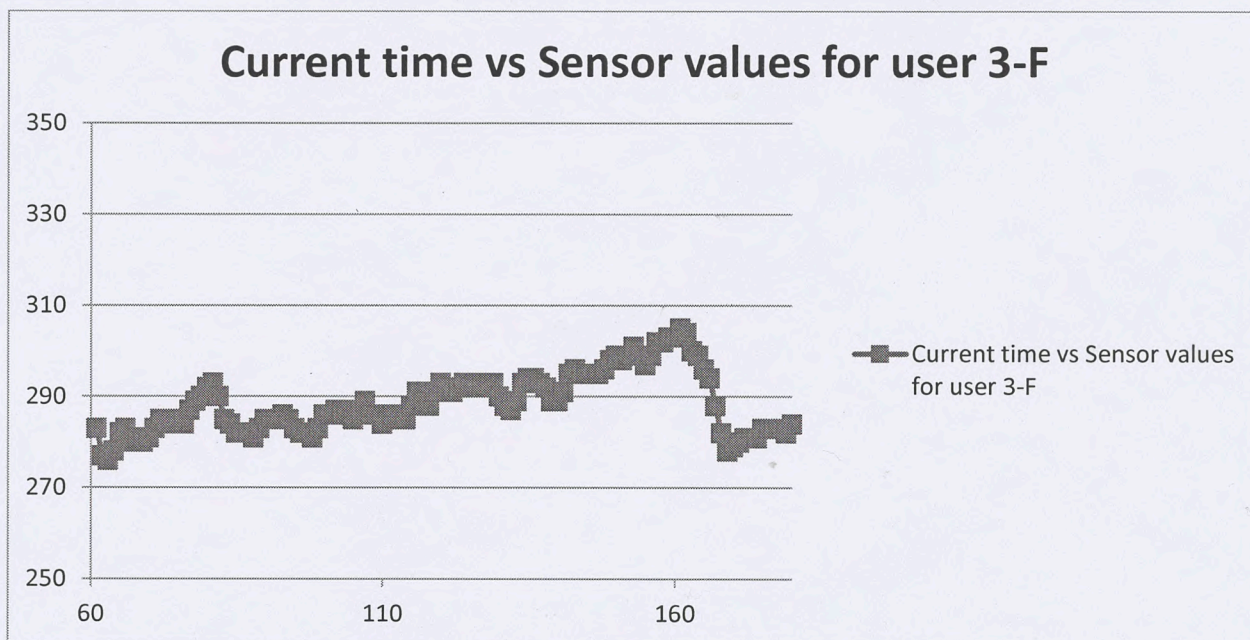

Figure 22: Current time vs Sensor values for User 3-F



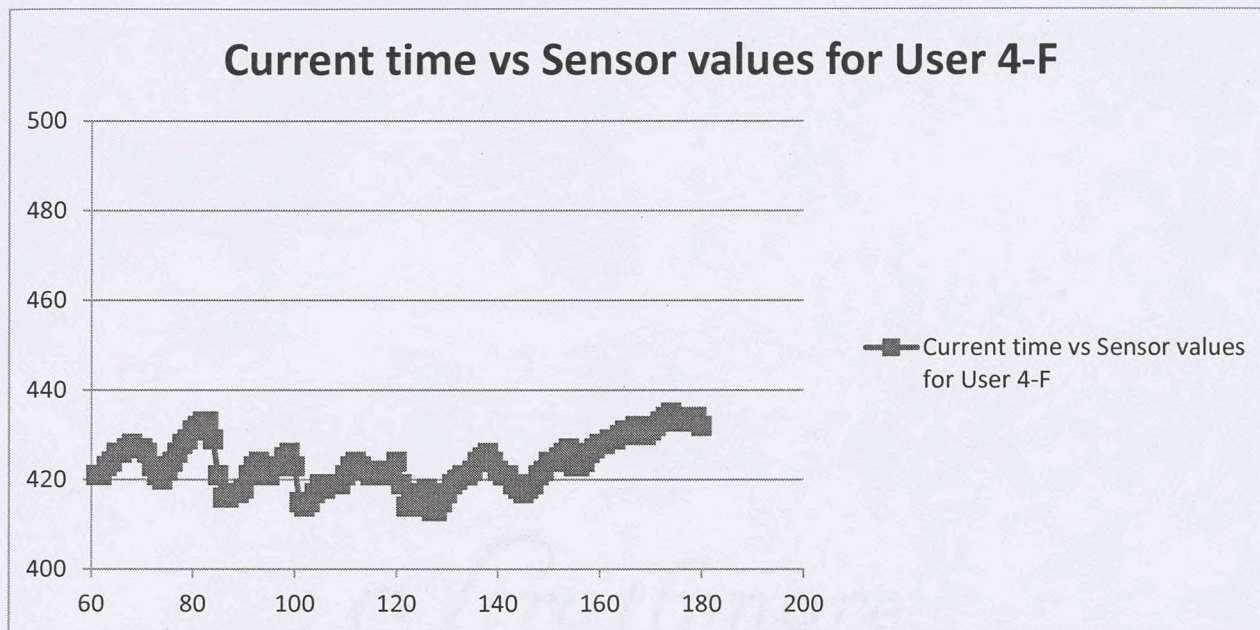

Figure 23: Current time vs Sensor values for User 4-F

### Users being relaxed for a minute:

Following are the graphs plotted against some of the users who experienced a steady level when there is no activity performed.

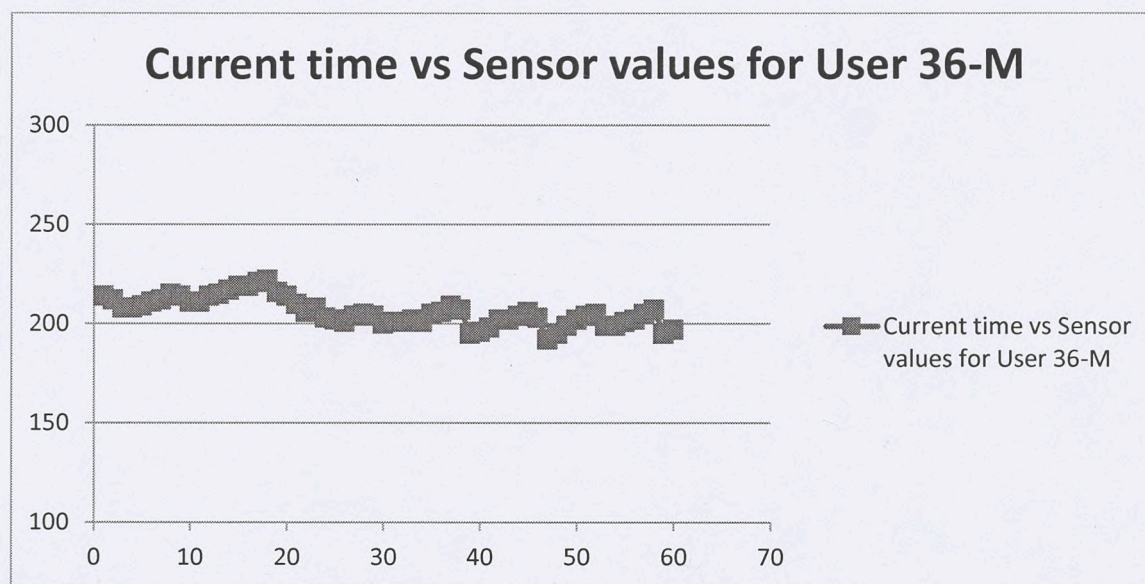

Figure 24: Current time vs Sensor values for User 36-M

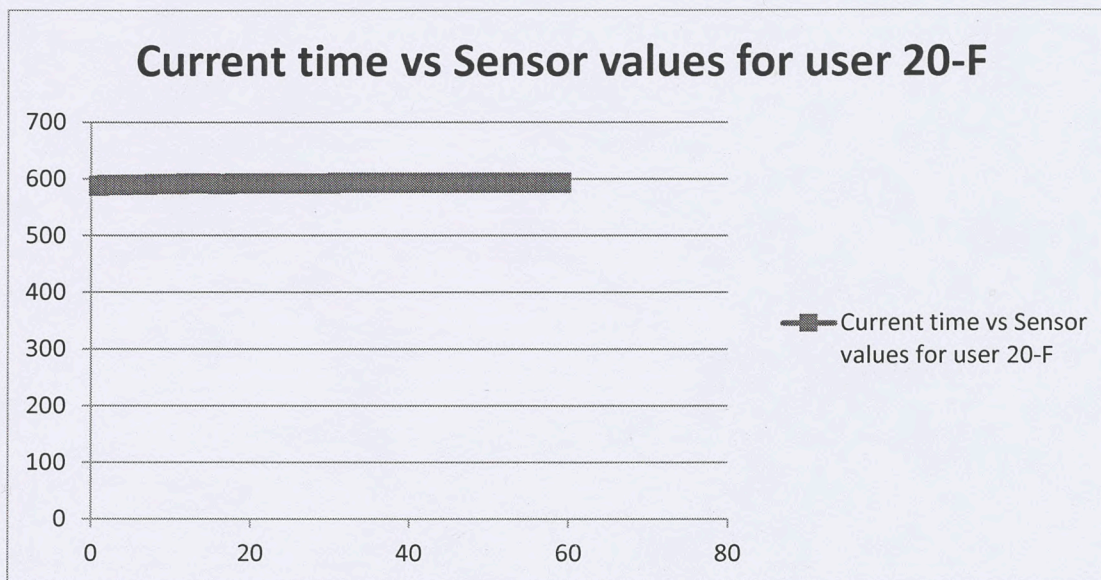

Figure 25: Current time vs Sensor values for User 20-F

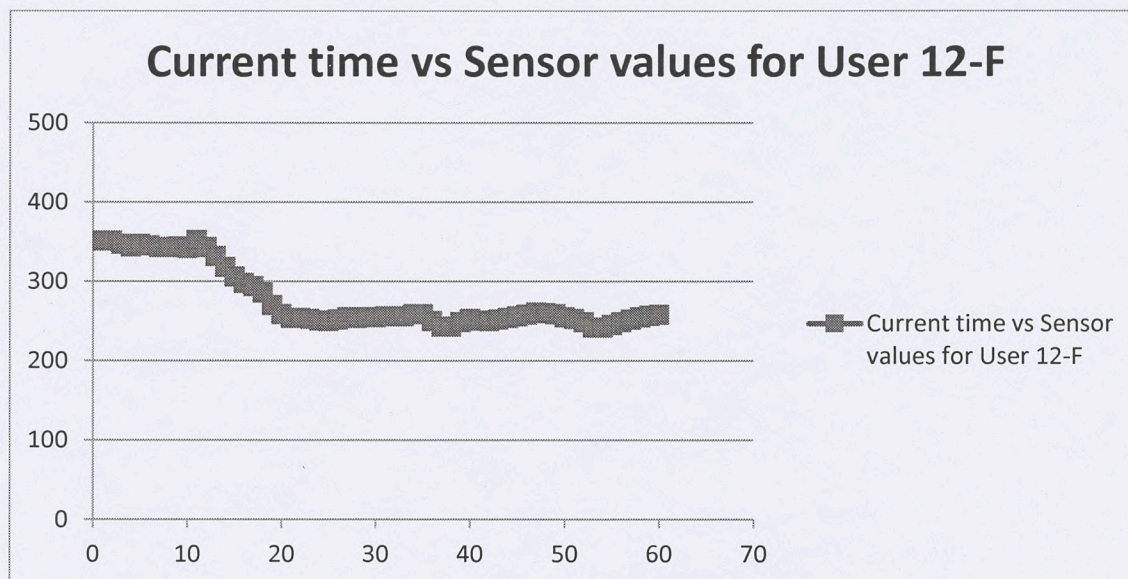

Figure 26: Current time vs Sensor values for User 12-F

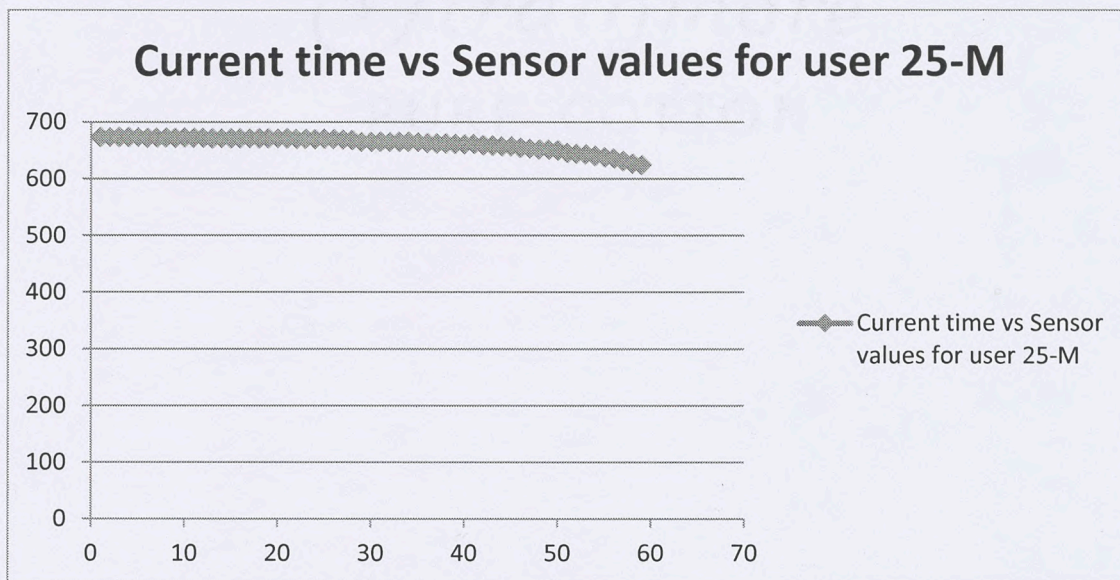

Figure 27: Current time vs Sensor values for User 25-M

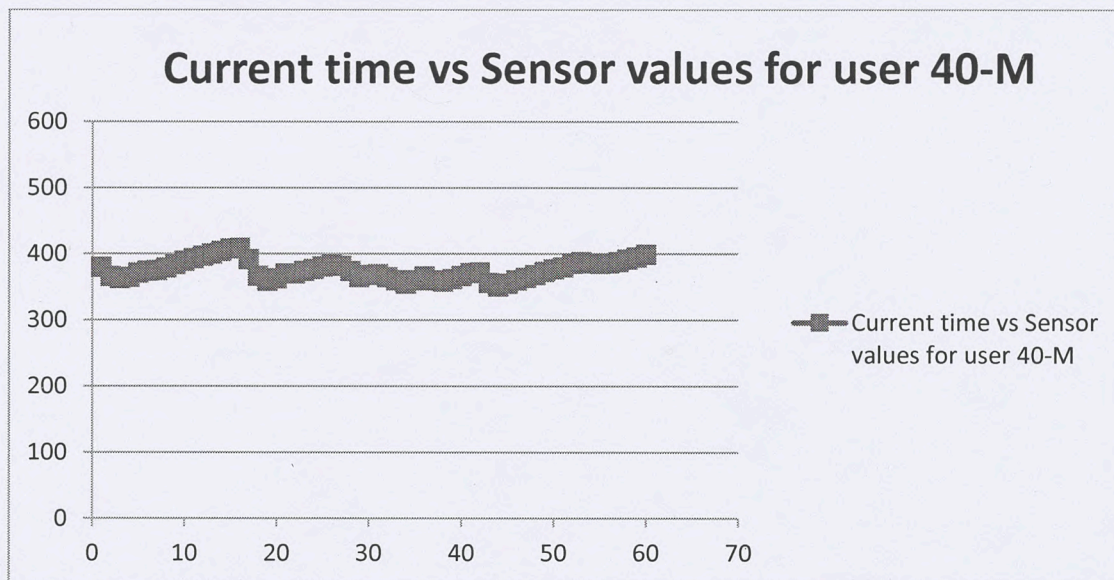

Figure 28: Current time vs Sensor values for User 40-M

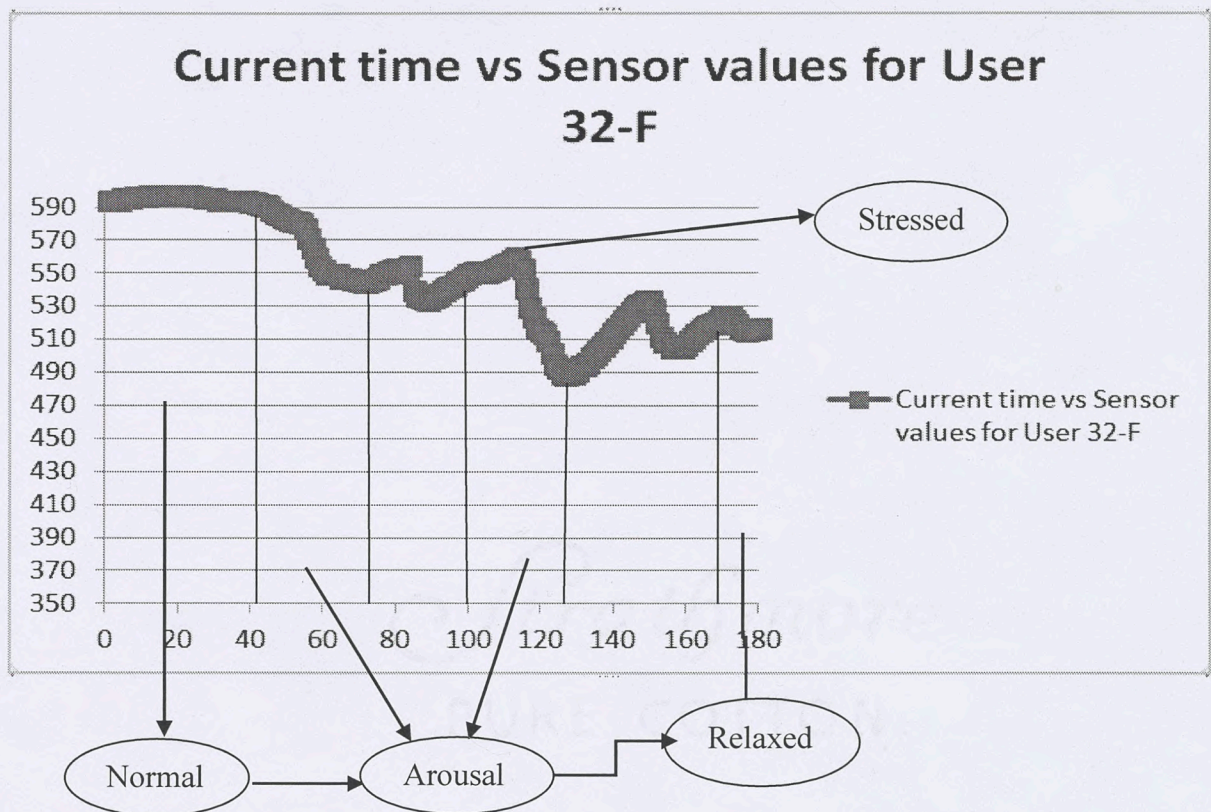

Figure 29: Current time vs Sensor values for User 32-F

By considering the above graph for the user 32-F, based on the data collected, we determined the stages of variation which are Normal, Arousal and Relaxed. Normal is the stage considered when there is no major variation in the conductance level and arousal is explained as the variation levels that occur while undergoing any kind of activity and finally relaxed stage is considered as the level that gets to the normal skin conductance level after performing an activity.

## 4.2 Processing stages of the system developed

### 4.2.1 High level processing stages of the system:

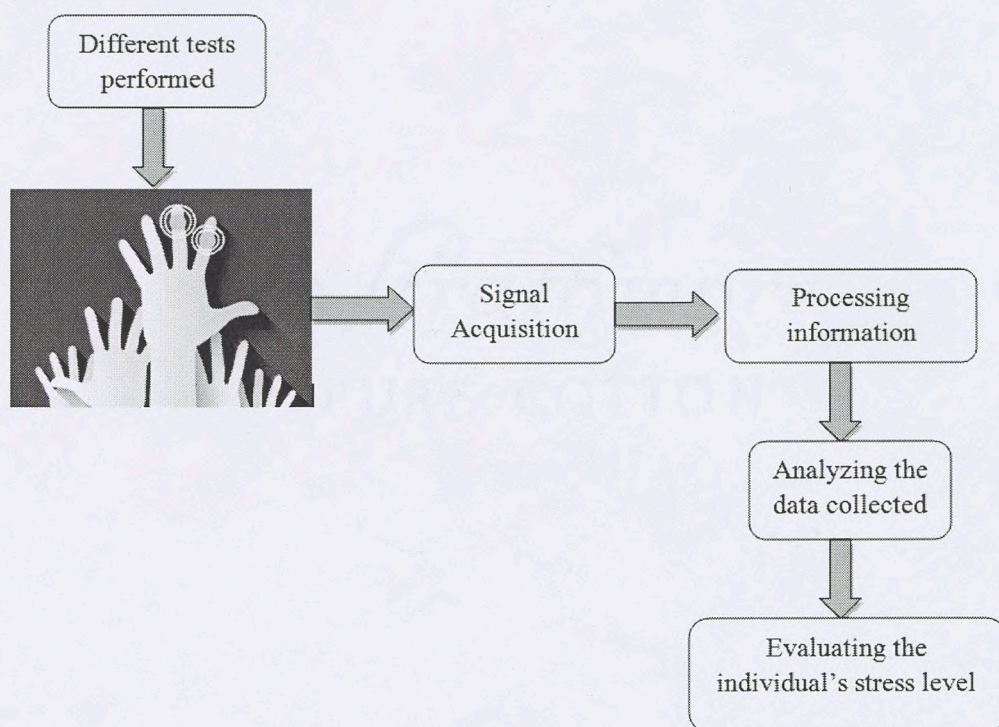

Figure 30: General diagram

From Figure 29, the processing stages of the system can be explained in detail. As the process flow indicates, different tests are performed with the help of GSR sensor that is mounted on the user's fingers. The data is collected by the Arduino for processing and will be sent to the mobile application for analysis, thereby displaying the individual's stress level based on the data sent by the Arduino via Bluetooth.

### 4.2.2 Acquisition Diagram

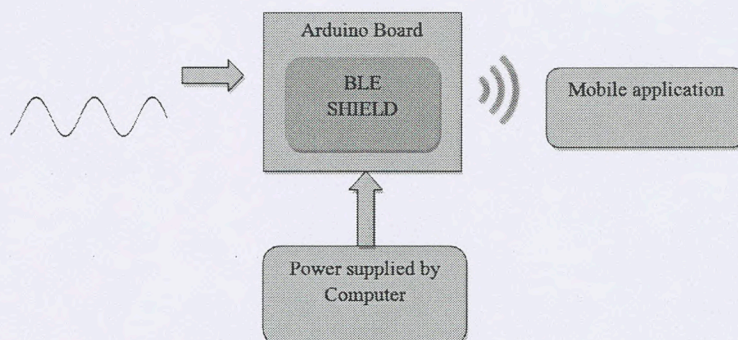

Figure 31: Acquisition diagram

The GSR signal data is provided as an input to the Arduino board for processing and the BLE Shield, a BLE device which is mounted on the Arduino board sends the data to the mobile application as shown in Figure 30. In order for the Arduino board to process the data, it has to be equipped with a power supply either through a USB cable connected to a computer or any other direct power sources.

### 4.2.3 Circuit Diagram

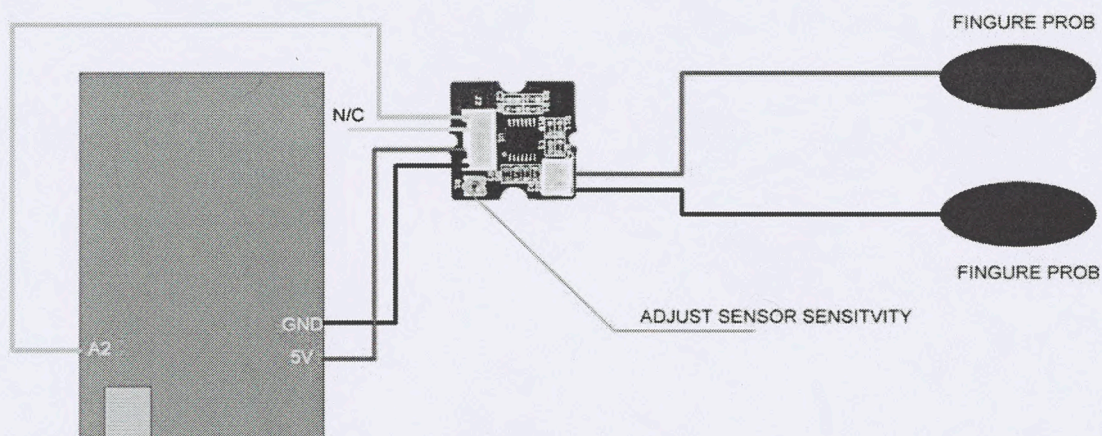

Figure 32: Circuit diagram that connects the Arduino to the GSR sensor

From Figure 31, the two finger probs of the GSR sensor are connected to the Arduino. As we need to supply a small amount of potential to the user's skin in order to collect the changes in the electrodermal activity, one of the finger probs is connected to the 5v power pin and the other one is connected to the GND (Ground) pin. The Analog pin A2 is connected to the GSR sensor to receive the data from the sensor.

#### 4.2.4 Device function

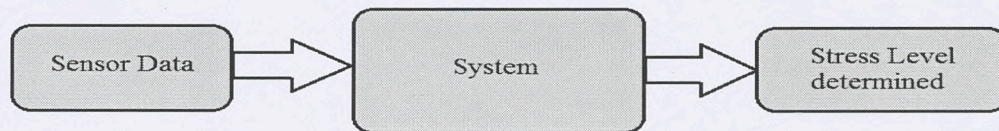

Figure 33: Functionality of the device

Figure 32 explains how the device functions in a pictorial view. The GSR sensor collects the electrical conductance of the skin from the user through the two electrodes mounted on the fingers and transmits it to the smart phone application via Bluetooth and the stress level can be analyzed in the application.

#### 4.2.5 Processing stage:

In this stage, it is necessary to differentiate the data collected when the user is in stress and when he/she is not.

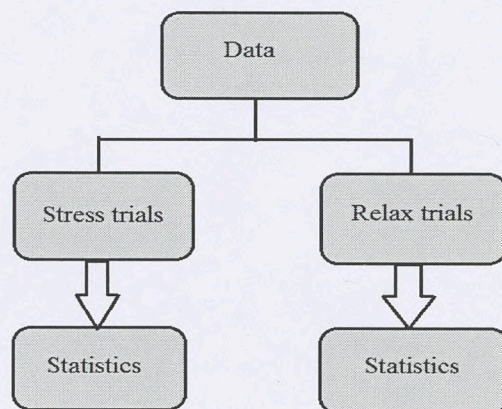

Figure 34: Processing stages

According to the Figure 33 above, we separated the data based on stress situations and relax situations and applied certain statistics to analyze the data collected.

### **4.3 Advantages:**

- Compact in Size and Affordable – costs around \$50.
- Portable - easily handled by anyone.
- The user can analyze his or her own individual stress level without the help of a doctor.
- Risks are minimal posing no kinds of side effects

#### **4.3.1 How this system would be advantageous to improve people's lives:**

- It can provide real-time feedback to the patients at any time, either as a warning of medical emergency or as a monitoring aid during daily operations.
- Can significantly decrease the number of nursing visits to hospitals with the help of this personal stress monitoring system.
- As the side effects of stress are adverse in nature, this system can help in monitoring the unhealthy states, so that the user could be able to be cautious about his health and treats it in an appropriate manner.
- Therefore, successful stress regulation plays an important role in maintaining health and wellness.

### **4.4 Limitations of the System:**

- This system can be only applicable to our hand fingers where it can be used to measure the skin conductance response.
- It cannot determine the user personality.

### **4.5 Conclusion**

There has been a significant increase in the development of wearable sensors for health monitoring systems. Continuous stress monitoring may help users better understand their stress patterns and provide physicians with more reliable data for interventions. This thesis has



identified some casual and unusual trends in the behavioral patterns constructed from the GSR sensor data collected. Galvanic skin response measurement plays as one of the important elements in certain psychotherapy and behavioral therapy treatments. We know that there is a relationship between stress and anxiety levels to the response of the skin to conductivity. Not only as a part of lie detector test, but also we could use the GSR sensor in various medical applications to analyze the patient's psychological state. From the tests performed and data collected, the GSR device detects whether there has been any change in any kind of activity performed or in the activity of being relaxed. It has also been observed that as there are some subjects who are unfamiliar with the process performed, they obtained highest average phasic skin conductance levels when compared to others who are aware of the process performed. Therefore, GSR sensor can be used effectively in finding the affective states of a user.

#### 4.6 Future work

There lies lot more work in the future of Affective computing. Technologies implemented to automatically recognize stress act as a valuable source to prevent chronic psychological stress, hypertension, PTSD (Post Traumatic Stress Disorder), autism and pathophysiological risks associated with those. The introduction of comfortable wearable sensors has created new opportunities to evaluate stress in real-life environments, but there is a great variation about how people experience stress and how they experience it physiologically. Moreover, it would be helpful if a system can identify the emotional state of a user depending on some of the psychological factors like motivation arousal and anxiety personal concentration.

#### References

- Akane Sano and Paul Johns, M. C. (2015). HealthAware: An Advice system for Stress, Sleep, Diet and Exercise .
- Asha Kapur, A. K.-B. (2005). Gesture Based Affective Computing on Motion Capture Data.
- Associates, D. K. (2014, January 29). *Coping with different kinds of Stress*.
- Banafa, A. (2014, July 24). Retrieved from Your computer will feel your pain.

- Chong L. LimaU, C. R. (1996). Decomposing skin conductance into tonic and phasic components.
- Dr Jason J Braithwaite, D. D. (2013). A Guide for Analysing Electrodermal Activity (EDA) & Skin Conductance Responses (SCRs) for Psychological Experiments.
- Global Organization for Stress, Stress solutions for the world.* (2009). (Global Organization for Stress)
- Inc., I. S. (2013). *Galvanic Skin Response and Investigation into Cheating.*
- Javier Hernandez, P. P. (2014). Under Pressure: Sensing stress of computer users .
- Jennifer Healey, J. S. (1999). Quantifying Driver Stress: Developing a system for collecting and processing Bio-metric signals in Natural situations .
- Kirsch, D. (1999). The Affective Tigger: a study on the construction of an emotionally reactive toy .
- Lisetti C., N. F. (2003). Developing multimodal intelligent affective interfaces for Tele-home healthcare.
- Marrin, R. W. (1999). Analysis of Affective Musical Expression with the Conductor's Jacket.
- Picard, J. S. (2011). The Galvactivator: A glove that senses and communicates skin conductivity.
- Picard, R. (1997). MIT Press.
- Platform, I. B. (2015). *GSR sensor and its working.*
- Products, A. (n.d.). *Arduino Uno & Genuino Uno.*
- Redbearlab.com. (n.d.).
- Rivera, J. H. (2015). Towards Wearable Stress Measurement .
- Rouse, M. (2006, September). *Affective Computing.*
- S.Lerner, J. (2014). Emotions and Decision Making.

Sano, R. W. (2013). Stress Recognition using Wearable sensors and Mobile phone .

Scheirer, R. W. (1999). Affective Objects.

Vyzas, R. W. (1998). Affective Pattern Classification.

Wickramasinghe, D. K. (2015). *Arduino DS1307 LCD Clock* .

I have submitted this thesis in partial fulfillment of the requirements for the degree of Master of Science

05/31/2017

Date



Sneha Gogineni

We approve of the thesis of Sneha Gogineni as presented here.

6/1/2017

Date



Lydia Ray, Ph.D.  
Assistant Professor, Thesis Advisor

6/6/2017

Date

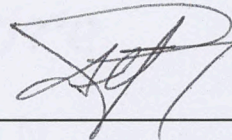

Alfredo Perez, Ph. D.  
Assistant Professor

6/6/2017

Date

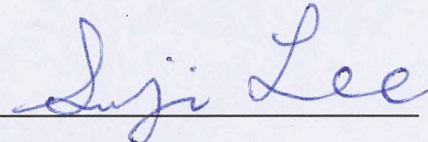

Suk Lee, Ph.D.  
Assistant Professor

6/8/2017

Date



Rania Hodhod, Ph.D.  
Assistant Chair/Professor

6/8/2017

Date

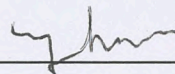

Wayne Summers, Ph.D.  
Distinguished Chairperson  
Professor of Computer Science

