

University of Denver

Digital Commons @ DU

---

Electronic Theses and Dissertations

Graduate Studies

---

1-1-2009

## A Model for Electrical Communication Between Cochlear Implants and the Brain

Douglas A. Miller  
*University of Denver*

Follow this and additional works at: <https://digitalcommons.du.edu/etd>



Part of the [Biomedical Devices and Instrumentation Commons](#), [Speech and Hearing Science Commons](#), and the [Speech Pathology and Audiology Commons](#)

---

### Recommended Citation

Miller, Douglas A., "A Model for Electrical Communication Between Cochlear Implants and the Brain" (2009). *Electronic Theses and Dissertations*. 431.  
<https://digitalcommons.du.edu/etd/431>

This Thesis is brought to you for free and open access by the Graduate Studies at Digital Commons @ DU. It has been accepted for inclusion in Electronic Theses and Dissertations by an authorized administrator of Digital Commons @ DU. For more information, please contact [jennifer.cox@du.edu](mailto:jennifer.cox@du.edu), [dig-commons@du.edu](mailto:dig-commons@du.edu).

A MODEL FOR ELECTRICAL COMMUNICATION BETWEEN  
COCHLEAR IMPLANTS AND THE BRAIN

---

A Thesis  
Presented to  
the Faculty of Engineering and Computer Science  
University of Denver

---

In Partial Fulfillment  
of the Requirements for the Degree  
Master of Science

---

by  
Douglas A. Miller  
June 2009  
Advisor: Mohammad A. Matin

Author: Douglas A. Miller  
Title: A MODEL FOR ELECTRICAL COMMUNICATION BETWEEN  
COCHLEAR IMPLANTS AND THE BRAIN  
Advisor: Mohammad A. Matin  
Degree Date: June 2009

## ABSTRACT

In the last thirty years, cochlear implants have become an invaluable instrument in the treatment of severe-to-profound hearing impairment. An important aspect of research in the continued development of cochlear implants is the *in vivo* assessment of signal processing algorithms intended to improve perception of speech and other auditory signals. In trying to determine how closely cochlear implant recipients process sound relative to the processing done by a normal auditory system, various assessment techniques have been applied. The most common technique has been measurement of auditory evoked potentials (AEPs), which involves the recording of neural responses to auditory stimulation. Depending on the latency of the observed response, the evoked potential indicates neural activity at various ascending neurological structures of the auditory system. Although there have been a number of publications on the topic of AEPs in cochlear implant subjects, there is a need for better measurement and research techniques to obtain more in-depth information to facilitate research on effectiveness of signal processing approaches in cochlear implants.

The research presented herein explored the use of MatLab for the purpose of developing a model for electrically evoked auditory brainstem responses (EABRs). The EABR is commonly measured in hearing-impaired patients who

have cochlear implants, via electrical stimulation delivered from electrodes in the implanted array. The simulation model developed in this study took as its input the stimulus current intensity level, and used function vectors and equations derived from measured EABRs, to generate an approximation of the evoked surface potentials. A function vector was used to represent the combined firing of the neurons of the auditory nervous system that are needed to elicit a measurable response. Equations were derived to represent the latency and stimulus amplitude scaling functions. The simulation also accounted for other neural activity that can be present in and contaminate an ABR recording, and reduced it through time-locked averaging of the simulated response.

Predicted waveforms from the MatLab model were compared both to published waveforms from a cochlear implant recipient, and a series of EABR waveforms measured by the author in other cochlear implant recipients. Measurement of the EABRs required specialized interfacing of a commercial recording system with the signal processors of the patients' cochlear implants. A novel measurement technique was also used to obtain more frequency-specific information than usually obtained. Although the nonlinearities normally present in the auditory system were not considered in this MatLab simulation, the model nevertheless performed well and delivered results comparing favorably with the results measured from the research subjects.

## ACKNOWLEDGEMENTS

I am indebted to my wife, Carol, and my daughters Tessa, Emily, and Laura, for their help, encouragement, and patience while I spent many hours on this project.

I would also like to express sincere gratitude to my advisor, Prof. Mohammad A. Matin, for his guidance and support.

This research was supported in part by Cochlear Americas, a division of Cochlear Ltd, Sydney Australia.

## TABLE OF CONTENTS

ABSTRACT .....	ii
LIST OF TABLES .....	vi
LIST OF FIGURES .....	vii
INTRODUCTION .....	1
BACKGROUND .....	4
Overview Of The Human Auditory System .....	4
Fundamentals Of Cochlear Implants .....	8
Overview Of Auditory Evoked Potentials And Their Measurement.....	19
Evaluation of AEPs in Cochlear Implant Recipients .....	33
Frequency Specificity and the EABR .....	53
Computer Modeling of AEPs.....	57
EXPERIMENTAL METHODS.....	59
Measurement of EABRs in Cochlear Implant Recipients .....	59
Subjects .....	59
Instrumentation and Procedures.....	59
Analysis Technique.....	63
EABR Model .....	63
RESULTS AND ANALYSIS.....	68
Measured EABRs.....	68
EABR Model .....	79
Measured EABRs versus Predicted EABRs .....	81
DISCUSSION.....	86
CONCLUSIONS.....	92
APPENDIX A.....	100
MATLAB Code .....	100
APPENDIX B .....	102
LIST OF PUBLICATIONS .....	102

LIST OF TABLES

Table 1. Demographics and Cochlear Implant Information for the Subjects Used  
in EABR Measurements.....60

## LIST OF FIGURES

Figure 1. Illustration of the peripheral human auditory system. (From: <a href="http://en.wikipedia.org/wiki/Auditory_system#Ear">http://en.wikipedia.org/wiki/Auditory_system#Ear</a> ). .....	5
Figure 3. Block diagram of a typical cochlear implant.....	11
Figure 4. Basic functioning of a cochlear implant in a deaf ear. (From: <a href="http://www.cochlearamericas.com/Experience/13.asp">http://www.cochlearamericas.com/Experience/13.asp</a> ).....	12
Figure 5. The family of auditory evoked potentials from short latencies to long latencies after stimulation. (From Katz, 1994, page 318).....	21
Figure 6. Typical AEP recording system. (From Katz, 1994, page 323). .....	23
Figure 7. An example of an auditory brainstem response (ABR) elicited in a normal hearing adult subject using standard acoustic click stimuli presented at a high intensity level. (From Katz, 1994, page 320). .....	27
Figure 8. An example of LLR waveforms showing the response to two speech stimuli, the syllable /di/, which was the "standard" stimuli, and the syllable /da/, which was the "deviant" stimuli. The P300 is seen in the deviant waveform and also in the difference waveform at the bottom, produced with simple subtraction of the common waveform from the deviant waveform. (From Micco et al., 1995). .....	32
Figure 9. EABRs recorded from one cochlear implant recipient from three different electrodes in the intracochlear array. (From Firzt <i>et al.</i> , 2002).....	38
Figure 10. Grand average LLRs for the four groups of children, illustrating latency decreases with increasing cochlear implant experience. (From Sharma <i>et al.</i> , 2002). .....	42
Figure 11. P300 waveforms from all 5 cochlear implant subjects and 1 normal hearing control. (From Jordan <i>et al.</i> , 1997). .....	46
Figure 12. Representative P300 responses from 4 cochlear implant recipients to the common stimulus /di/ and the odd stimulus /da/. Also shown are the difference waveforms. (From Micco <i>et al.</i> , 1995). .....	48



Figure 13. P300s elicited by stimulus contrasts of increasing difficulty in one cochlear implant patient (left column). Difference-stimulograms calculated for these (middle column). Transfer functions of bandpass filters implemented in the CIS speech processing algorithm of the cochlear implant – bold lines indicate the frequencies of the standard and deviant tone bursts stimulating adjacent implant electrodes (right column). (From Muhler <i>et al.</i> , 2004). .....	49
Figure 14. Schematic illustration of Cochlear Ltd Nucleus implant electrode array, which would be inserted and coiled into the cochlear partition. There are 22 electrodes, numbered starting with E1 furthest from the tip, to E22 near the tip of the array. ....	54
Figure 15. Greenwood frequency map (From Roland <i>et al.</i> , 2004). The points for a 22 electrode array can be loosely interpolated along the map. In a 22 electrode array, electrode E1 is generally inserted to approximately 4.0 mm. The apex of the cochlea extends to about 32.0 mm in an adult human. Since a standard 22-electrode array is approximately 18.0 mm in length, electrode E22 is inserted to approximately 22.0 mm in the cochlea. ....	56
Figure 16. Unitary response derived through deconvolution of measured auditory brainstem response results (From Fobel, 2003). ....	65
Figure 17. Wide bipolar stimulation EABRs from Subject 1 (left panel) and Subject 2, right ear (right panel), showing data across stimulus intensity levels from “loud comfortable” down to threshold level. ....	69
Figure 18. Narrow bipolar stimulation EABRs from Subject 1 (upper panel), and Subject 2, right ear (lower panel), showing data across the electrode pairings for stimulation at either maximum output or “loud comfort” level. ....	71
Figure 19. Narrow bipolar stimulation EABRs from Subject 2, left ear (upper panel), and Subject 3 (lower panel), showing data across the electrode pairings for stimulation at either maximum output or “loud comfort” level. ....	72
Figure 20. Narrow bipolar stimulation EABRs from Subject 4 (upper panel), and Subject 5, right ear (lower panel), showing data across the electrode pairings for stimulation at either maximum output or “loud comfort” level. ....	73
Figure 21. Narrow bipolar stimulation EABRs from Subject 6, showing data across the electrode pairings for stimulation at either maximum output or “loud comfort” level. ....	74

Figure 22. Measured latencies across all ears with identifiable Waves I, III, and V, for each of the narrow bipolar electrode pairings. ....	75
Figure 23. Measured amplitudes across all ears with identifiable Waves I, III, and V, for each of the narrow bipolar electrode pairings. ....	76
Figure 24. Means and standard deviations of latencies for identifiable Waves I, III, and V for each of the narrow bipolar electrode pairings. Also shown are best-fit linear regression lines. ....	77
Figure 25. Means and standard deviations of amplitudes for identifiable Waves I, III, and V for each of the narrow bipolar electrode pairings. ....	78
Figure 27. The panel on the left shows modeled EABRs generated by MatLab, while the panels on the right are EABRs recorded from research Subject 1. R1 waveforms were elicited from the basal electrode pair E1 and E11, and R2 waveforms were elicited from the apical electrode pair E11 and E22, across a range of stimulation intensities. ....	83
Figure 28. The panel on the left shows modeled EABRs generated by MatLab, while the panels on the right are EABRs recorded from the right ear of research Subject 2. R3 waveforms were elicited from the basal electrode pair E1 and E11, while R4 waveforms were elicited from the apical electrode pair E10 and E21, across a range of stimulation intensities. ....	84

## CHAPTER 1

### INTRODUCTION

Over the past three decades, cochlear implants (CIs) have increasingly improved in technology and performance in the treatment of severe-to-profound hearing impairment, and along with these improvements has come an expanding patient candidacy criteria and corresponding challenges in the development of effective signal processing algorithms. An important aspect of research in the continued development of cochlear implants is the *in vivo* assessment of signal processing algorithms intended to improve perception of speech and other auditory signals.

A widely applied technique for this purpose is measurement of auditory evoked potentials (AEPs), which involves the recording of neural responses to auditory stimulation. Depending on the latency of the observed response, the evoked potential indicates neural activity at various ascending neurological structures of the auditory system. AEPs can be measured for several purposes including examination of the integrity of the auditory pathway and evaluation of functioning of the cochlear implant. Recently, as signal processing techniques have evolved to include greater interest in frequency-specific aspects of the place of stimulation in the cochlea, more interest has developed in using AEPs to better

understand the nervous system response to different signal processing approaches to assist in development of better approaches.

One AEP often measured in deaf patients who have multichannel cochlear implants is the electrically evoked auditory brainstem responses (EABR), an early AEP occurring in the first 10 to 20 seconds after stimulation of the auditory system. EABR recordings represent a summation of individual action potentials generated by each neuron along the auditory neural pathway, with stimulation via electrical pulses delivered to the electrodes in an array implanted in the cochlea.

In this thesis, a computer MatLab model of electrically-evoked auditory brainstem responses (EABRs) was developed. The input to the model was the stimulus current intensity level. A function vector representing combined firing of auditory neurons, and equations derived from measured acoustic auditory brainstem responses (ABRs) representing latency and amplitude scaling functions, were used to generate a response approximation. The simulation also reduced contamination from other neural activity via time-locked averaging. Results using this model were compared to both published data and data collected from CI patients for use in development and evaluation of the model. Measurement of the EABRs required specialized interfacing of a commercial recording system with the signal processors of the patients' cochlear implants. The simulation model may be useful for better understanding the characteristics of the EABR and their relevance to CI patient performance. In turn, this information may assist in development of better CI signal processing and fitting

schemes. A novel measurement technique was also tried, in which distally close pairs of electrodes were used rather than those widely spaced, so that responses were obtained that represented high-frequency stimulation from the basal area of the cochlea versus low-frequency stimulation from the apical area of the cochlea.

## CHAPTER 2

### BACKGROUND

#### **Overview Of The Human Auditory System**

The normal peripheral human auditory system, as shown in Figure 1, is very efficient at transducing acoustic signals in the frequency range of approximately 20 to 18,000 Hertz, and for intensities across a range of about 140 decibels, into electrical (neural) impulses. These impulses are then delivered via the auditory nerve to the cerebral cortex, where they are processed for the recognition of sound.

The peripheral auditory system includes the outer, middle, and inner ears. The outer ear, consisting of the pinna and external auditory canal, work to collect and filter incoming sound. The pinna acts as a collector and the ear canal functions as a filter, emphasizing key frequencies of speech. The middle ear, which consists of the tympanic membrane (ear drum) and the ossicles (the three small bones of the middle ear, the malleus, incus and stapes), converts acoustic energy into mechanical motion, and also provides impedance matching between the air-filled outer ear and the fluid-filled inner ear. The malleus is attached to the tympanic membrane and is caused to move whenever sound waves impact on the

tympanic membrane. The incus connects the malleus to the stapes, and the stapes is attached to the membrane covering an oval window into the cochlea, and acts as a piston to transmit the motion of the ossicular chain to the fluid inside the cochlea. The area ratio of the tympanic membrane and the oval window, and the lever ratio of the ossicular chain, together improve the impedance mismatch (caused by the air to fluid interface) by approximately 30:1.

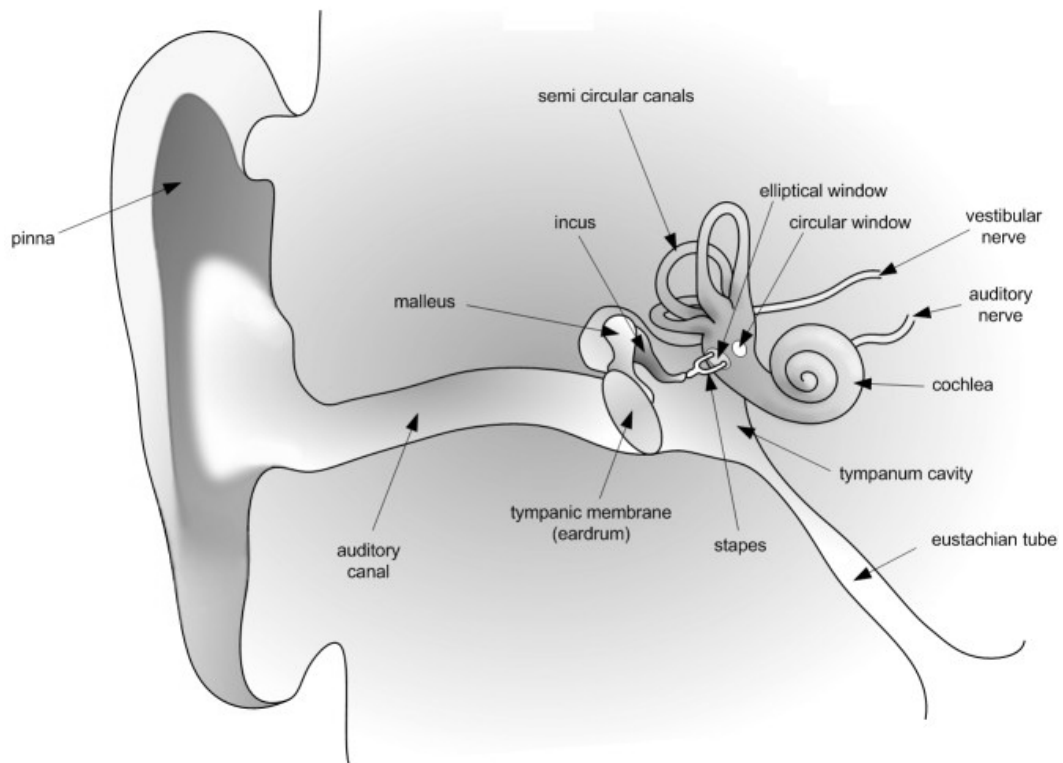

Figure 1. Illustration of the peripheral human auditory system. (From: [http://en.wikipedia.org/wiki/Auditory\\_system#Ear](http://en.wikipedia.org/wiki/Auditory_system#Ear)).

The inner ear consists of the cochlea, a fluid-filled chamber containing neural structures that convert the vibrations induced in the cochlear fluids into

electrical impulses that are conveyed to the brain via the auditory nerve. Another function of the cochlea is to help resolve the incoming signals into their constituent frequency components. Also considered components of the inner ear are the vestibular labyrinths, which assist in maintaining equilibrium and balance.

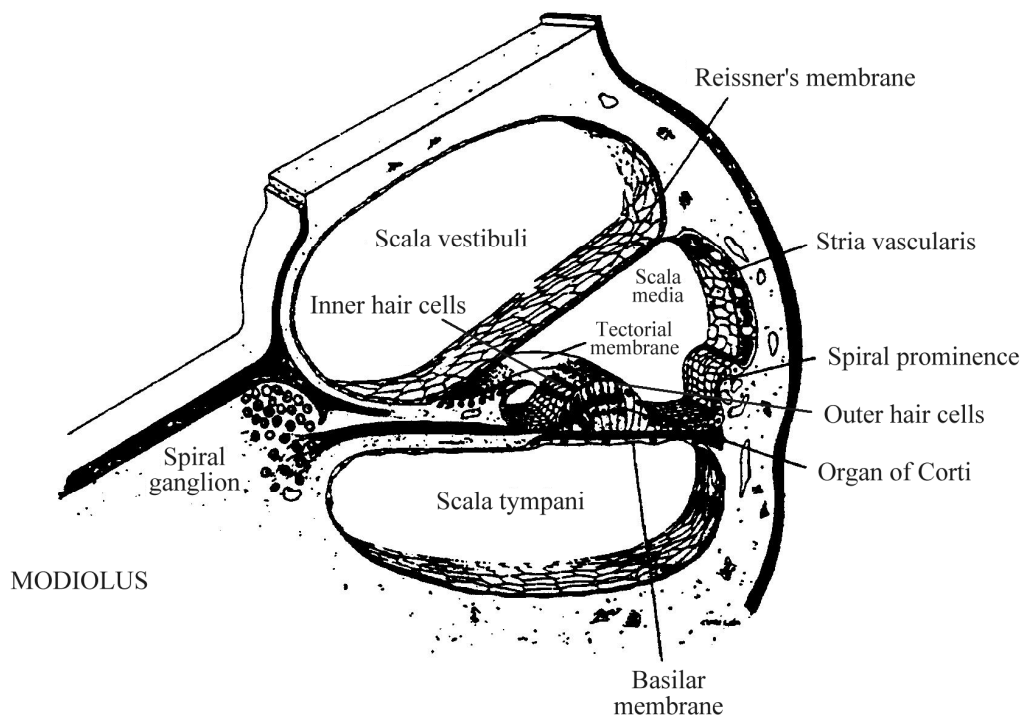

Figure 2. Structures of the cochlea in cross-section. (Adapted from Bloom, W. & Fawcett, D.W. (1975). *A Textbook of Histology*, 10th edition. Philadelphia: W.B. Saunders.)

Movement of the stapes at the oval window causes vibrations to travel through the fluid-filled canals of the cochlea (shown in cross-section in Figure 2; the scala). The pressure changes in the scala tympani are transmitted to the adjacent scala media, and a traveling wave is thus initiated on the basilar



membrane. As the basilar membrane moves up and down, the stereocilia of the hair cells on the basilar membrane are moved back and forth (sheared) because they are also attached to the tectorial membrane, which vibrates differently. This shearing or bending of the stereocilia causes stretching of the hair cell plasma membrane and generation of electric potential changes.

The central auditory nervous system consists of the auditory nerve, brainstem, and auditory cortex. Depolarization of the hair cell in the inner ear causes an action potential which results in an electrical impulse being transmitted to the spiral ganglion and from there on to the cochlear nerve (a division of the VIIIth cranial, auditory, nerve) which collects the electrical impulses and delivers them to the brainstem. The auditory cortex in the brain receives the electrical impulses from the cochlea and further resolves the signals into sound perceptions.

In the auditory system, the most common type of permanent hearing impairment is described as “sensorineural” hearing loss. In this disorder, the outer and middle ear function normally, but there is a loss of function in either the inner ear or the auditory nervous system. Most commonly the loss is in the ability of the cochlear neural structures to convert vibrational energy in the cochlear fluids into electrical energy. Outer and/or inner hair cells in the cochlea are either not correctly formed (congenital impairment) or have been damaged or lost (e.g. by exposure to excessively loud noise or ototoxic drugs, by presbycusis from aging, and/or due to auto-immune or viral diseases).

## **Fundamentals Of Cochlear Implants**

For lesser degrees of sensorineural hearing impairment, the treatment of choice is amplification with hearing aids. Acoustic amplifiers work very well for many patients, but when the level of sensorineural hearing impairment reaches a severe-to-profound degree of sensitivity loss (or “deafness”), they provide limited or no assistance. Cochlear implants are one option available for the treatment of patients with bilateral deafness. These devices try to replace the function of the inner and outer hair cells of the cochlea by providing electrical stimuli to the spiral ganglion cells, which then convey the electrical impulses to the auditory nerve for hearing sensation.

Modern multi-channel cochlear implants have proven to be a highly successful intervention for individuals with severe-to-profound hearing loss, producing good speech recognition in quiet for most patients, as well as many other benefits (e.g., Parkinson *et al.*, 2002). Over the course of the past 30 years, cochlear implant technology has improved dramatically. The first cochlear implants were simple single-channel models introduced around 1980 by researchers at the House Ear Institute in Los Angeles. Subsequently, in the 1990s, the first multi-channel models were introduced by researchers in Australia. At present there are three major manufacturers of cochlear implants, with the

Cochlear Ltd. (Sydney, Australia) Nucleus<sup>®</sup> implant series (N22, N24, and Freedom models) comprising approximately 70% of worldwide sales.

Along with technological improvements in cochlear implants has come greatly improved performances (Krueger *et al.*, 2008) resulting in an expanding patient candidacy criteria and a growing acceptance of the safety and efficacy of this intervention strategy. For example, the first Nucleus cochlear implant was only approved by the U.S. FDA for completely “deaf” patients (those who had no usable hearing at all; i.e. profound hearing loss defined as hearing thresholds  $\geq 90$  dB HL<sup>1</sup> when evaluated with pure tone stimuli produced by a clinical audiometer) and who scored 0% on tests of speech understanding ability. In addition, only adult patients were approved for implantation of this Class III medical device, and implanted adults could expect to receive only about 30% correct speech understanding test scores, sometimes even with the use of lipreading (visual facial cues). As technology improved, the FDA-approved candidacy broadened to include children over the age of 12 months old. In addition, children over the age of 2 years old can now have low-frequency thresholds of  $\geq 70$  dB HL, and adults can have low-frequency hearing thresholds of  $\geq 50$  dB HL, as long as mid- to high-frequency hearing thresholds are  $\geq 90$  dB HL. With current technology, adult implant recipients can now expect to achieve

---

<sup>1</sup> HL = the Hearing Level scale used by audiologists, with a reference of 0 dB HL indicating the average sound pressure level (SPL) at which normal hearing young adults can detect a pure tone of a given frequency approximately 50% of the time. At 1000 Hz, 0 dB HL = 7 dB SPL, but higher SPL values are needed at higher or lower frequencies for threshold hearing.

an average of 70% to 80% correct on speech understanding tests *without* using lipreading cues (Parkinson *et al.*, 2002), and many can talk on the telephone.

An illustration of the basic components of a cochlear implant is shown in Figure 3 and an illustration of its basic functioning is shown in Figure 4.

Cochlear implants directly stimulate the nerve electrically, thus bypassing the damaged hair cells in the cochlea of a person with profound hearing impairment. The external speech processor picks up the acoustic sound wave via a microphone, accomplishes needed front-end processing such as compression of the dynamic range, converts the signal to digital form, processes it, and sends it across the skin via a transcutaneous connection using internal and external magnets (transmitter receiver and coil). The electrode bands in the array implanted in the cochlea send out electrical pulses to stimulate the nerve fibers leading from the hair cells. These nerve fibers lead to the VIII cranial (auditory) nerve, and travel up way stations of the auditory brainstem and mid-brain to the cortex, where the stimulation is perceived as sound.

Signal processing in cochlear implants is intended to encode the more complex acoustic stimulus into a more simplistic set of electrical stimulation parameters. A significant factor in the improved performances with cochlear implants over time has been both the more complex signal processing algorithms developed to encode the acoustic signal into an electrical signal for transmission to the brain, and advances in implant electrode technology. Early single-channel (single-electrode) implants could only encode by rate and intensity of

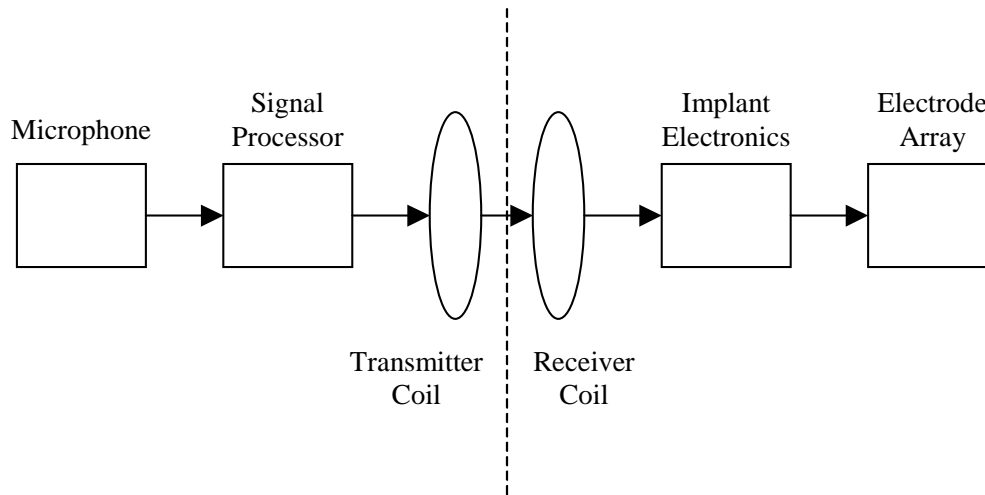

Figure 3. Block diagram of a typical cochlear implant.

stimulation. Multi-channel cochlear implants can take advantage of the frequency selectivity of the nerve fibers from the cochlea, so that low frequencies are primarily mediated by electrodes placed at the apical end of the cochlea (reflecting the wavelength of traveling waves produced by low-frequency acoustic stimuli) and high frequencies are primarily mediated by electrodes placed at the basal end of the cochlea (reflecting the shorter wavelength of traveling waves produced by high-frequency stimuli). So place can be used in addition to rate and intensity to encode the stimuli for interpretation by the brain.

The signal processing approaches used in cochlear implants attempt to provide cues for the basic components of speech without allowing significant overlap of the electrical current spread and thus potential cancellation. There is a practical limit to the number of electrodes that can be placed in the cochlea and therefore there is a limit to the spectral resolution of the stimuli. It is also not

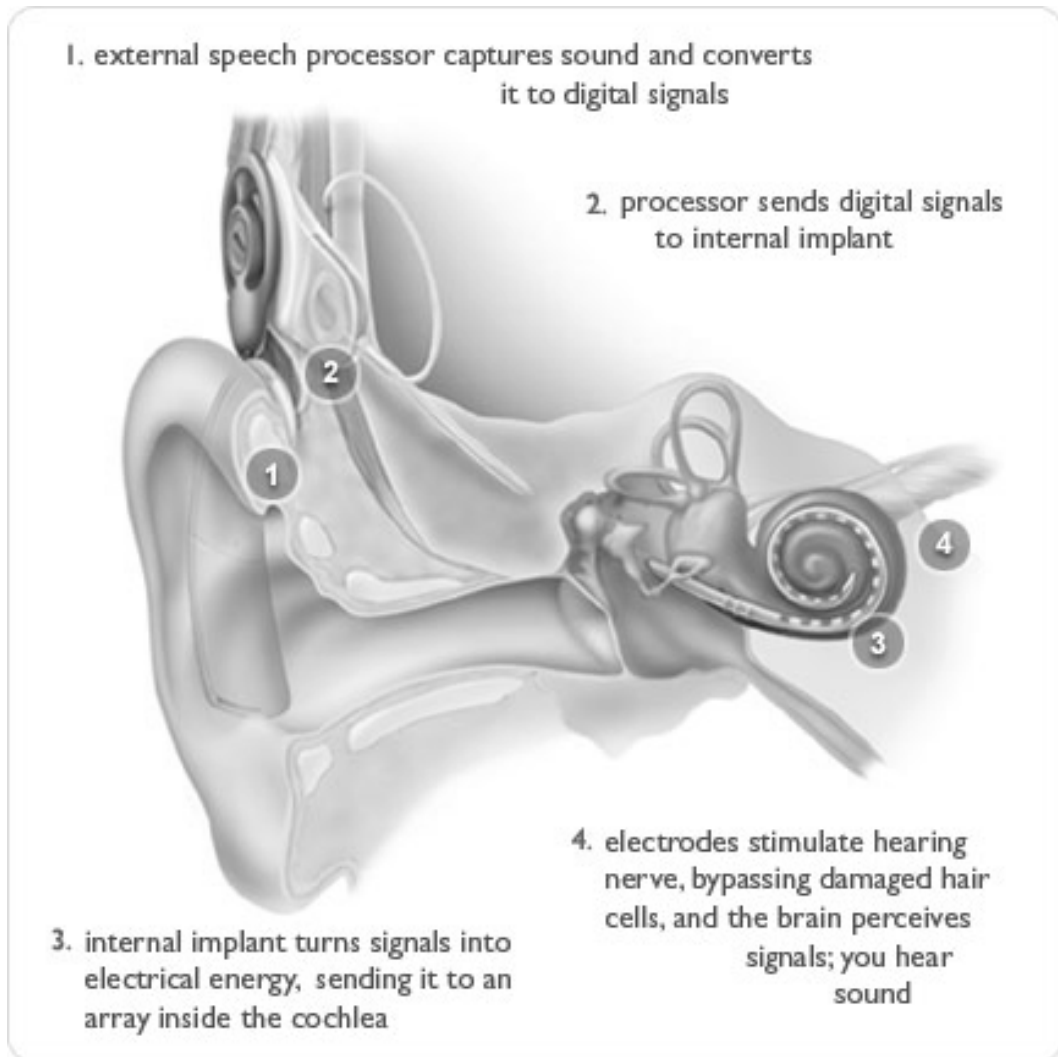

Figure 4. Basic functioning of a cochlear implant in a deaf ear. (From: <http://www.cochlearamericas.com/Experience/13.asp>)

clear exactly how the spiral ganglion cells should be stimulated in order to produce meaningful perception. Location of stimulation, relative amplitude, temporal information and spectral information all need to be represented in the encoding, but exactly how to do that is not yet fully understood. Frequency of the stimulus can be encoded as either place of stimulation in the cochlea (more

apically for lower frequencies) or as rate of stimulation (higher rates for higher frequencies). Loudness of the stimulus can be encoded by amplitude of the pulse, but rate of stimulation can also impact loudness perception.

Several different techniques are currently being used in commercially available cochlear implants. They include algorithms that concentrate on the dominant spectral components of the signal, algorithms that concentrate on temporal characteristics, or a combination of these two techniques. One earlier signal processing approach used in the Nucleus<sup>®</sup> implants was the SPEAK approach (for “Spectral Peak”). SPEAK consists of a filterbank from which a specified number of maxima are chosen per sample and then stimulation provided on the electrodes according to those filterbanks with the maxima. A complicating factor is that the stimulus current can spread and overlap from adjacent stimulating electrodes, which is one reason SPEAK is no longer widely used. Thus, another stimulation approach has been to more widely separate the electrodes stimulated and/or to interleave the timing of the electrode stimulations. In the Nucleus implant series, this is called the CIS approach (for “Continuous Interleaved Stimulation”). The most recent approach in the Nucleus implants has been called ACE (for “Advanced Combination Encoder”). ACE attempts to combine the best of the SPEAK and CIS strategies with some additional features. Most recently, along with a growing trend toward implanting bilaterally profoundly impaired patients with bilateral implants (Muller *et al.*, 2002), new

signal processing techniques are being explored including attention to the need for coordinated input from the two ears.

A complicating factor is that some present day implant recipients also maintain some low-frequency acoustic hearing in addition to the electric hearing, and this must be factored into the signal processing approach. In fact, there are some “Hybrid” shorter electrode cochlear implants in development intended to capitalize on this fact (e.g. Turner *et al.*, 2008). As signal processing techniques and the audiometric profiles of candidates have changed, there is a growing need for more analysis tools to better understand the functioning of the auditory system of cochlear implant recipients, in order to develop the most efficacious signal processing approaches.

Audiologists are the professionals who evaluate hearing function of patients both preoperatively and postoperatively, and provide fitting and rehabilitation with a cochlear implant after it has been implanted by an otologic surgeon and there has been a sufficient period for healing. Testing includes measurement of thresholds using pure tones or narrow frequency bands of noises, and recognition of phonemes (individual sounds), words, and sentences to quantitatively assess the subject’s performance with the cochlear implant. Qualitative measures are also used in which the subject is asked to complete questionnaires in which they specify how they perceive they are doing in different listening conditions or to judge the perceptual loudness or pleasantness of sounds.



While current behavioral testing paradigms provide what is needed for a reasonable fitting of the cochlear implant parameters for the cooperative adult patient, more objective measures would be useful in more difficult-to-fit cases, infants and young children, and to provide a more definitive characterization of the auditory perception provided at the cerebral cortex by cochlear implant signal processing.

Thus, there is a desire for additional objective measures that would assess how closely the stimulus encoding provides neural responses that match those of a normally functioning auditory system. Specifically, such measures would look at the level of the cerebral cortex and provide a detailed assessment of cortical activity for a normal hearing person versus someone using a cochlear implant. It is also important to note that there are still some unknown factors in terms of preoperative indicators for postoperative success. Many cochlear implant patients achieve open-set (no cue) speech recognition for sentence materials of 70% or more (today, some achieve 100%), but others perform more poorly, with maximum postoperative performance reaching less than 40% [Parkinson *et al*, 2002]. Although some of the factors that contribute to better or poorer performance are known, such as age at development of deafness and the number of years of deafness, it is still possible for two patients with equally good prognostic indicators to perform differently postimplantation. A better understanding of how electrical impulses delivered from cochlear implants provide a different cortical representation than acoustic input from a normal

auditory system might assist in determining a means to provide more consistently improved performance across patients.

In trying to determine how closely cochlear implant recipients process sound relative to the processing done by a normal hearing system, various assessment techniques have been employed, including functional imaging techniques such as fMRI (functional Magnetic Resonance Imaging) and PET (Positron Emission Tomography) scans. These have met with some limited success but there is only a relatively small research literature available on the topic and some potential problems with the use of these measurements with cochlear implant recipients.

PET uses a radioactive tracer injected into the bloodstream. Tissue that is more active requires more glucose from the vascular system and therefore receives a greater quantity of the tracer, so the PET scanner measures the concentration of this tracer in the tissues being scanned. Johnsrude *et al.* (2002) evaluated subjects with cochlear implants by PET scan throughout their post-implantation rehabilitation period. There was little or no auditory function as identified by PET scan immediately following implantation, but as the subjects learned to utilize the new form of processed sound, patterns resembling those of normal hearing subjects were observed. There were, however, some significant differences in the cortical activation patterns of the normal control group and the fully rehabilitated cochlear implant group. The authors speculated that these differences were due to the auditory cortex organizing differently to cochlear

implant stimulation. Another study using PET in cochlear implant recipients was done by Naito *et al.* (1995) in which cortical activation was observed for noise and speech signals.

One problem with PET, however, is that it has a very low sampling rate that depends on the uptake of a radioactive tracer by the more active areas of the brain. The sample rate in PET is approximately 30 sec/sample, which is much too slow an acquisition to extract any temporal data with auditory signals. Further, PET has very low spatial resolution, around 2-5 mm, which produces a very granular image, making it difficult to resolve small variations that might occur in cortical responses. Thus, while PET can determine which areas of the auditory cortex are active in perceiving sound, the lack of temporal resolution means that patterns describing specific characteristics cannot be observed. In summary, then, PET can indicate which areas of the auditory cortex are used for general categories of acoustic stimuli, such as pure tones of differing frequencies, versus noise or speech, but it cannot provide more detailed information as to the specific neuronal activation patterns that permit recognition of auditory information. Another practical problem with PET is its limited availability and relatively high cost.

The fMRI also relies on the fact that greater blood flow to the tissue is required when the tissue is more active, and certain techniques with MRI scanners can measure relative blood flow rates in order to determine relative activity of the tissues being scanned. The most commonly used paradigm in fMRI is the BOLD

(Blood Oxygenation Level Dependent) response. Molecules in the blood respond to magnetic fields differently depending on the level of oxygen in the blood. The shortcoming of this technique is that the signal changes that are monitored are related to the focal hyperoxygenated blood in the blood vessels that provide drainage for the activated tissues. Therefore, neural activity is indirectly measured using fMRI, and the spatial distribution of the hyperoxygenation may not exactly correspond to the activated neurons (Scheffler *et al.*, 1998).

A problem in applying these measurements with cochlear implant recipients is that the MRI equipment used to measure cortical activation has a very high level of noise emanating from the equipment, making it difficult to present the desired acoustic test stimuli. Another problem is that fMRI can produce intense magnetic fields during operation, which can interfere with cochlear implants. The newer models of Nucleus implants and some of the Advanced Bionics implants have been approved for MRIs up to a field strength of 1.5 T (with the coil magnet removed), but MRI scanners in higher strengths are being used for diagnostics. Med-El implants have only been approved for MRI up to 0.3 T, and have a non-removable magnet that produces an artifact obscuring part of the brain. Several studies using fMRI were done using a percutaneous cochlear implant that is no longer produced, known as the Ineraid, because it did not have either implanted electronics or a coil (Melcher *et al.*, 1998; Lazeyras *et al.*, 2002; Seghier *et al.*, 2004). These studies did illustrate responses via electrical stimulation by the implant and tonotopic organization of the cortex for auditory

system stimulation. In summary, fMRI can provide some greater detail of neuronal activity than PET due to its greater temporal resolution, however, it is still not sufficient for fine modeling of auditory perceptual processes and cannot be used at high field strengths for current implant models. There is also the additional uncertainty injected by the fact that fMRI measures adjacent effects of the neuronal activation, rather than measuring the neuronal activity itself, and, again, the limited availability and high cost.

Given the limitations in functional brain imaging as a tool for objectively evaluating auditory response with cochlear implants, most researchers have instead used a far simpler and inexpensive approach, and with more success. This is the measurement of auditory evoked potentials (AEPs) with electrical stimulation via the cochlear implant. Modeling and evaluation using this latter approach is the topic of this thesis, and the following provides an overview of AEPs and their use in research with cochlear implants.

### **Overview Of Auditory Evoked Potentials And Their Measurement**

Human auditory evoked potentials (AEPs; also called auditory evoked responses or AERs) occur in the time frame of approximately 0 to 500 ms following the presentation of a stimulus to the ear. This time frame roughly equates to the time it takes neural impulses to travel up the auditory pathway from the periphery to the central nervous system and to be processed by the brain. Recordings of an AEP represent a summation of the individual action potentials

generated by each neuron along the auditory neural pathway. Evoked potential measurements essentially consist of summing (averaging) of the neural impulses (elicited potentials) generated by a series of EEG recordings collected with a common time base related to the stimuli, in order to attenuate neural impulses unrelated to the stimuli (“noise”). There are both commercial devices available to measure these potentials in their common clinical applications, and laboratory systems that have been specifically designed to accomplish more complex measurements for research. Evoked potentials are used clinically in the hearing field in a variety of applications including evaluation of the integrity of the auditory nervous system, evaluation of hearing sensitivity, and even fitting of hearing aids for patients who are difficult to test behaviorally.

The AEP components that are elicited by simple stimulation of the auditory system with a sound (typically a click or a tone) are commonly referred to as “evoked” or “exogenous” potentials. These potentials essentially illustrate temporally the activation of the auditory system without the need for conscious awareness of the stimuli by the subject. The shorter latency auditory evoked potentials can even be obtained from a comatose subject. In awake subjects, there is no volitional response required except that the subject must be suitably relaxed and still to avoid contamination of the responses from neural muscular artifacts. Exogenous potentials can be measured from the short latency range, middle latency range, and long latency ranges of the auditory response. Figure 5 shows the family of exogenous AEPs from the short latency response (SLR) to the

middle latency response (MLR) to the late latency response (LLR). The short latency response is also called the auditory brainstem response (ABR).

AEPs are typically measured noninvasively. A measurement set-up for evoked potentials would consist of the application of at least three disc-type electrodes to areas of the scalp, with one as ground. Electrode locations on the

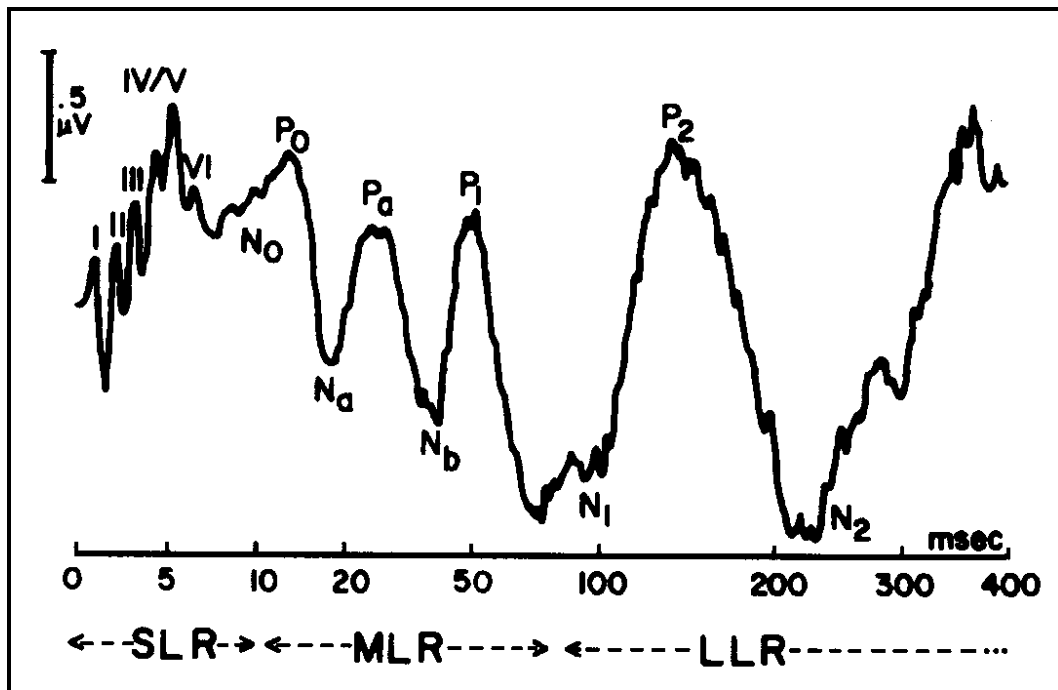

Figure 5. The family of auditory evoked potentials from short latencies to long latencies after stimulation. (From Katz, 1994, page 318).

head are described according to a standardized system. In this system, midline areas are labeled “C”, parietal lobe areas are labeled “P”, temporal lobe areas are labeled “T”, and frontal lobe areas are labeled “F”. Further, the right side of the head is given even numbers, the left side of the head is given odd numbers, and

the midline from the forehead to the base of the skull is labeled “z”. Thus, the vertex or top of the head location is labeled “Cz”, a location over the right temporal cortex is labeled “T4” and the corresponding spot over the left temporal cortex is “T3”, and so on. Electrode skull caps are also used in research applications to measure from multiple locations on the scalp in order to map the distribution of electrical activity.

A typical AEP measurement setup is illustrated schematically in Figure 6. The signal averager is triggered at the same time as stimulus delivery and the responses to multiple stimulus presentations are differentially amplified (electrodes placed at locations with expected high and low levels of electrical response to the stimulus, but equal EEG noise), filtered in the appropriate frequency range for the component under study (responses are lower in frequency at higher levels of the auditory nervous system), and averaged in order to improve the signal-to-noise ratio. Because the ongoing EEG (which is part of the “noise” in this application) is as likely to be positive as negative in any point in time, while the AEP is time-locked to the stimulus, the relatively tiny AEP (which is in  $\mu\text{V}$ ) can readily be extracted out of the large ongoing background EEG (which is in  $\text{mV}$ ). Some things can interfere with the efficacy of this procedure, such as interference from muscular artifacts that are also time-locked to the stimulus (for example, post-auricular muscle twitches) and the infusion of other electrical signals such as 60-cycle interference. The stimuli must also be presented at a repetition rate slow enough to prevent adaptation of the response, and the stimuli



must have a fast enough rise time that sufficient populations of neurons are simultaneously innervated.

Multi-channel measurements are often done to compare stimulation of one ear with measurement at the ipsilateral (same side) and contralateral (opposite side) cortex. Responses are typically analyzed in terms of latency from stimulation of the key peaks and troughs, or interpeak latency differences or

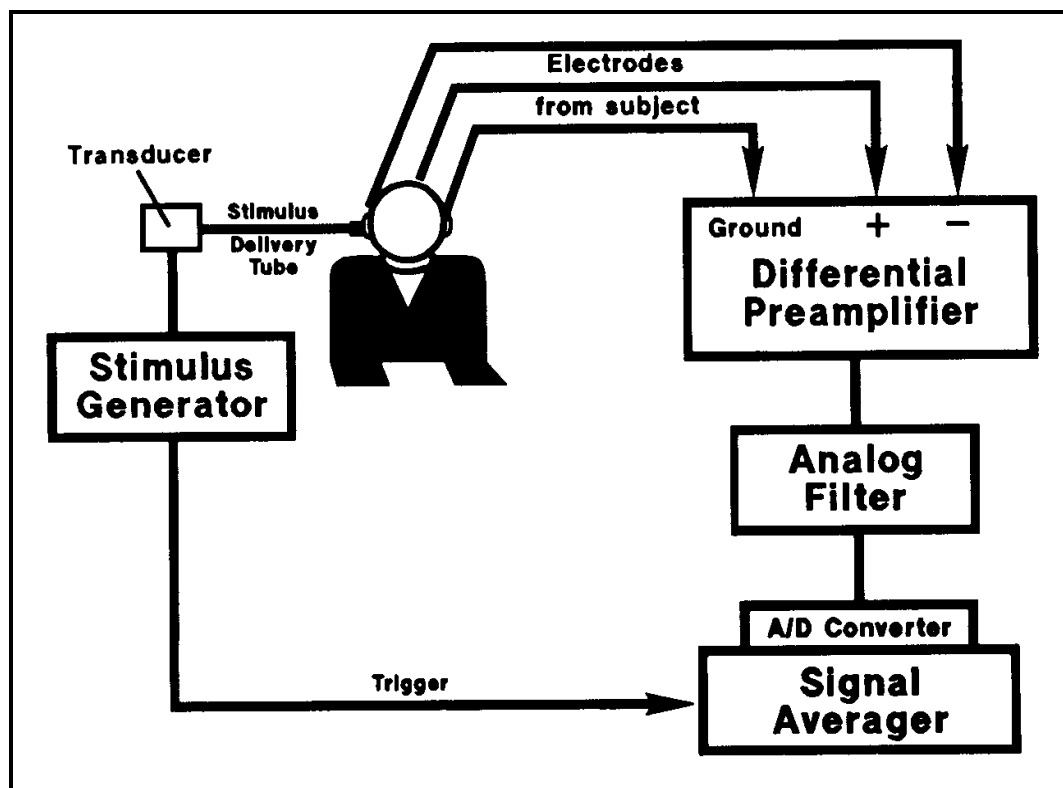

Figure 6. Typical AEP recording system. (From Katz, 1994, page 323).

interpeak amplitude ratios. Some more complex analysis techniques have been applied in recent years. As an example, the statistical principal components analysis (PCA) has occasionally been used in research studies to examine the area

under the waveform curve in terms of contribution to the variance of superimposed slow and fast response peaks such as can occur in the later latency cortical responses. The main types of auditory evoked and endogenous potentials are reviewed briefly below, followed by a review of the literature related to AEP evaluation in deaf patients using cochlear implants.

### *Cochlear and VIIIth Cranial Nerve Potentials*

The shortest latency (first) of the evoked potentials are several that emanate from the most peripheral part of the auditory system, the cochlea (inner ear). For example, AEPs known as the “cochlear microphonic” (CM) and the “summating potential” (SP) are both produced at the hair cells, and occur immediately after the stimulus. At the next level up the auditory system, the “action potential” (AP; also called the “compound action potential” or CAP) is produced at approximately 2 ms following stimulation and is from the VIII cranial (auditory) nerve. These early potentials are used clinically to assist in the diagnosis of some disorders like Endolymphatic Hydrops (Meniere’s disease), but the CM and SP have little to offer to the measurement of cochlear implant subjects since the implant itself stimulates as a replacement to defective or missing cochlear hair cells. The AP is thought to loosely correlate to the first peak (wave) of the auditory brainstem response described in the next section, and some studies have used AP measurements on subjects with cochlear implants (e.g. Gordon *et al.*, 2003).

### *Auditory Brainstem Response (ABR)*

The next level of measurement is that of the brainstem, where one of the most widely applied exogenous AEPS is measured. This short (or “early”) latency response is the “auditory brainstem response” (ABR). This is also sometimes referred to as the brainstem evoked potential (BSEP) or brainstem auditory evoked response (BAER). The ABR is produced by the auditory nerve and the structures of the auditory brainstem. The 5 to 7 (depending on measurement technique and patient) distinct peaks of the human ABR are measured over a time frame of approximately 2 to 15 ms following stimulation, and bandpass filter settings to measure the response are typically set at 100 to 3000 Hz. Usually 1000 to 2000 stimulus events are averaged.

The ABR is extremely important clinically in audiology and otology, as it can be used as a non-invasive means of screening for space-occupying lesions (tumors) in the auditory brainstem such as an acoustic neuroma (vestibular schwannoma), as well as to test sensitivity of hearing in infants and other difficult-to-test subjects (such as those who are non-verbal, non-cooperative, or mentally handicapped). A problem with testing hearing sensitivity with the acoustically stimulated ABR is that it does not produce very frequency-specific results. Responses are primarily from the mid to high-frequency regions when a click stimulus is utilized, yet tonal stimuli with an abrupt enough rise time to produce a response have substantial frequency splatter. In an attempt to obtain

frequency-specific low-frequency thresholds with the ABR, sometimes a 500 Hz pure tone is placed within a notched or high-pass masking noise to eliminate the effects of the unwanted high-frequency energy (e.g. Katz, page 381-382). The ABR has also been applied to the fitting of hearing aids in difficult-to-test subjects with some limited success. One of the reasons for the popularity of the ABR is that compared to the other AEPs it is relatively easy to measure, shows a fairly robust response, and is fully formed at a relatively young age.

An example of a normal ABR is shown in Figure 7 (from Katz, 1994, page 320). The peaks, generally referred to as “Waves”, are typically labeled with Roman numerals, and represent way-stations in the auditory nervous system. In general, Waves I and II represent distal and apical parts of the auditory nerve, Wave III represents the summed response from the cochlear nucleus, Wave IV represents response from the superior olivary, and Wave V-VII represents response from the medial geniculate (Vannier et al., 2002). Waves III-IV represent the level at which the auditory pathway crosses over to the contralateral side of the brain as well as continuing ipsilaterally. As seen in the figure, Waves II and IV are generally smaller in amplitude, and indeed, are frequently not identifiable. This is especially true in EABRs measured on cochlear implant patients. Wave V is the most robust, largest amplitude peak and in waveforms with poor morphology or with low levels of stimulation, sometimes only a Wave V is seen in an ABR trace.

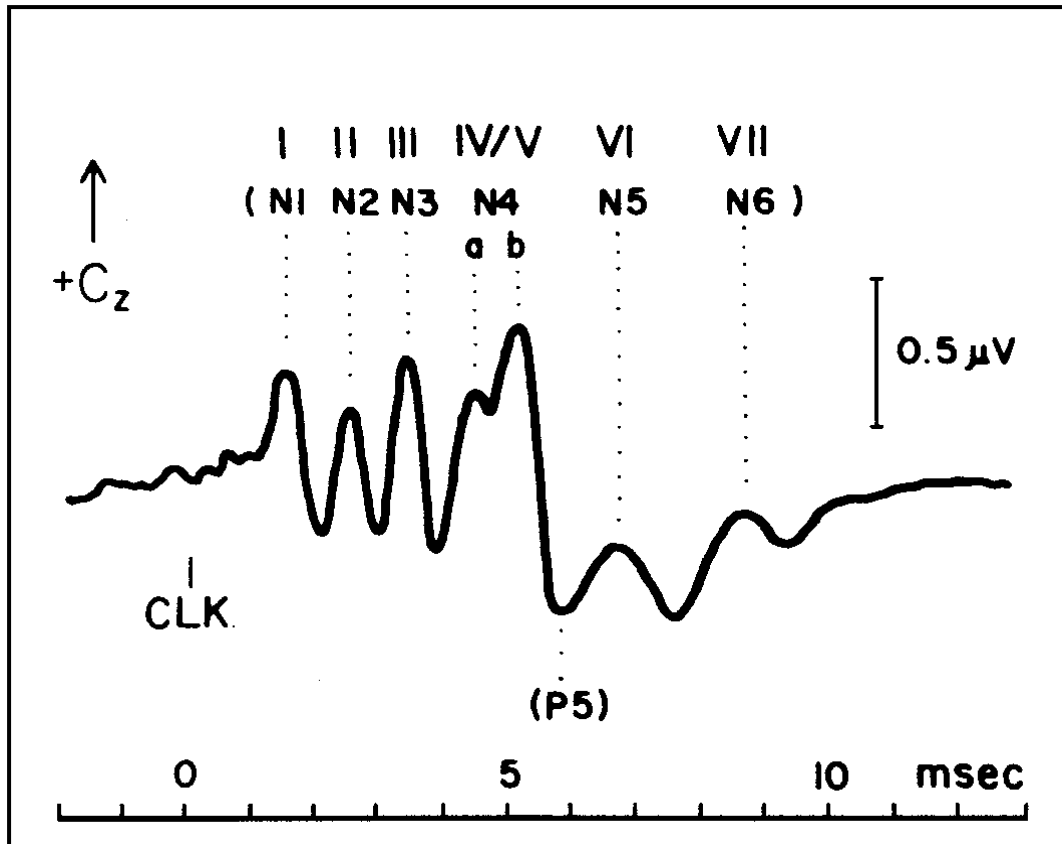

Figure 7. An example of an auditory brainstem response (ABR) elicited in a normal hearing adult subject using standard acoustic click stimuli presented at a high intensity level. (From Katz, 1994, page 320).

The main measurements typically applied to the ABR waveform are the latency and amplitudes of the peaks, the V/I amplitude ratio, and the I-III and III-V interwave latency differences. Increased latencies or reduced amplitudes in certain patterns can indicate either loss of hearing sensitivity, or poor integrity of the auditory system of the individual being measured (for example, due to a space-occupying lesion, a degenerative illness, or even advanced age). There have been a number of studies that have applied ABR measurements to cochlear

implant subjects (e.g. Firszt *et al.*, 1999, 2002; Hay-McCutcheon *et al.*, 2002; Thai-Van *et al.*, 2002; Gordon *et al.*, 2003, 2008; Gibson *et al.*, 2009) and some of these will be reviewed later in this paper.

### *Middle Latency Responses (MLR) and Steady-State Potential (SSP)*

The “middle latency response” (MLR; also called the auditory middle latency response or AMLR) is also an exogenous, evoked potential typically produced (like the ABR) with auditory stimulation by simple electrical square waves (clicks) or tonal stimulation with a fast enough rise time to elicit adequate synchronous responses from multiple populations of neurons. This AEP is produced at the thalamic auditory cortex and occurs approximately 10 to 50 ms following stimulation. Bandpass filter settings to measure it are typically set at 20 to 1000 Hz. It is a two-peaked response typically labeled as Na, Pa, Nb, and Pb (N for the negative troughs followed by P for the positive peaks). In general, the MLR is not as easy to measure as the ABR due to frequent contamination by post-auricular muscle (PAM) activity that occurs in the same time frame, and so it has not been seen as often in clinical application. However, it is sometimes used in exploration of the integrity of the higher level of the auditory nervous system that it represents relative to the ABR.

When a rate of 40 stimuli per second is used, the two middle latency peaks actually overlap in time and appear to reflect a neural synchronicity rate of the brain so that the response amplitude is increased overall and the peaks appear to

be continuously repeating. This synchronized recording is known as the “steady state potential” (SSP; also called the 40 Hz event-related potential or 40 Hz ERP) and has seen increased use as a measurement tool for hearing sensitivity due to its greater amplitude and robustness relative to the conventional MLR, and its greater frequency specificity than the ABR. Some researchers have applied the MLR to cochlear implant subjects (e.g. Firszt *et al.*, 1999, 2002), but to the author’s knowledge none have applied the SSP.

#### *Late Latency Response (LLR)*

The exogenous evoked response from the highest part of the auditory system, produced at the cerebral cortex, is commonly called the “late latency response” (LLR), although about an equal number of authors refer to it as the “cortical potential” (CP). It also is a two-peaked response with the key components commonly labeled P1, N1, and P2, occurring in the region of 50-300 ms following stimulus delivery. It is even lower in frequency than the MLR (bandpass filter settings to measure it are typically set at 1 to 100 Hz). It can be elicited with click, tonal or even speech stimuli (such as short syllables).

Like the MLR it offers more frequency specificity than the ABR, but it is also more difficult to reliably measure at threshold levels and doesn’t mature to fully adult form until approximately age 7. Although it is a cortical level potential, it still requires no volitional response from the subject to elicit the main

two-peaked response. The LLR has been evaluated in cochlear implant recipients with some success (e.g. Sharma *et al.*, 2002a, 2002b, 2004; Firszt *et al.*, 2002).

### *Endogenous Potentials*

The second major category of AEPs, and one that has seen more interest in recent years but is still relatively in its infancy in auditory research, is that of the “endogenous” potentials. Unlike the evoked (exogenous) potentials, the subject under measurement must be awake and sometimes actually paying attention to the task for their measurement. Thus, these potentials measure how the brain is processing the signals with cognition, rather than just reflecting simple activation of the auditory nervous system pathway.

There are several endogenous potentials, but only two, the P300 and MMN, have been extensively studied, and only these two have been examined in cochlear implant research to date, with most studies utilizing the P300 (Oviatt & Kileny, 1991; Kileny, 1991; Kraus *et al.*, 1993; Micco *et al.*, 1995; Jordon *et al.*, 1997, Kaga & Kodera, 1999; Okusa *et al.*, 1999; Groenen *et al.*, 2001; Singh *et al.*, 2004).

#### **Late Positive Component (P300)**

Also called the “late positive component”, the P300 (also sometimes called the P3) is a third peak seen at the end of the time region of the LLR (at approximately 300 ms depending on measurement techniques and the patient), but



it is only produced when the subject is aware of a difference in one stimulus in a stimulus train. For example, a P300 can be elicited when a series of “standard” stimuli (for example, 1000 Hz tone pips) are given and then a “deviant” stimulus (for example, a 3000 Hz tone pip) is inserted randomly and given less frequently than the main stimuli (e.g. to represent perhaps only 20% of the stimulus presentations in the total number presented). The patient’s task is typically to push a button to indicate when the deviant stimulus occurred. The requirement to push a button focuses the patient’s attention on the task. When the evoked responses produced from the deviant stimuli are averaged in a separate bin in the AEP signal averager from those produced by the commonly heard stimuli, the P300 will appear at the end of the LLR for the rarer stimuli but will not be seen in the traces for the common stimuli. Thus, the P300 appears to represent a cognitive awareness of ‘same’ versus ‘different’ in the auditory domain.

The P300 originates from a number of auditory and non-auditory centers of the brain, including the medial temporal lobe, the parietal lobe, the reticular thalamic nuclei, and the septohippocampal system. An example of a normal P300 is shown in Figure 8.

### **Mismatch Negativity (MMN)**

Like the P300, it is thought that the MMN may be useful in determining the central neurophysiologic events underlying speech perception. The MMN is elicited with a similar “oddball paradigm” for measurement like used for the



Figure 8. An example of LLR waveforms showing the response to two speech stimuli, the syllable /di/, which was the "standard" stimuli, and the syllable /da/, which was the "deviant" stimuli. The P300 is seen in the deviant waveform and also in the difference waveform at the bottom, produced with simple subtraction of the common waveform from the deviant waveform. (From Micco et al., 1995).

P300, but it is only seen in the difference between the waveforms for the common stimuli and for the “deviant” stimuli (with subtraction of one waveform from the other). Smaller differences in contrast between the common and deviant stimuli can produce an MMN even when they don’t produce a P300 (which requires fairly substantial differences in the stimuli). Another difference from the P300 is that the MMN does not require a behavioral response, and in fact the subject’s attention can be focused on another task and an MMN will still be produced while a P300 would not.

## **Evaluation of AEPs in Cochlear Implant Recipients**

Many studies have been conducted using AEPs to assess cochlear implant subjects, but they have varied in their objectives and means. Some have compared children implanted at various ages with the intent of determining whether an earlier age for receiving a cochlear implant results in more normal-like responses over time (e.g. Sharma *et al.*, 2005). Some researchers have attempted to obtain acoustically evoked AEPs prior to cochlear implantation (in patients who have some residual hearing ability) and then to compare them to those obtained with electrical stimulation after implantation. These studies would offer a within-subject comparison of acoustically versus electrically evoked AEPs, but since all cochlear implant candidates have limited acoustic sensitivity pre-surgery, it has been difficult to obtain much data in this manner. Most studies, therefore, have merely obtained electrically evoked AEPs from cochlear implant recipients, and sometimes comparing them to responses from age-matched normal hearing subjects using acoustic stimuli.

Electrically evoked AEPs have been used in cochlear implant patients to assess neural integrity and implant function, as a means to explain variability in performance, and as a way to program the threshold (Ts) and comfort (Cs) settings of the device in young infants or children who may have no auditory experience and limited language. In addition, the measurement of EABRs in cochlear implant recipients is sometimes intended to obtain a better understanding

of the differences in neural activation between using acoustic stimuli in a normal hearing ear and using electrical stimuli in an ear with a damaged cochlea. For purposes of the current study, EABRs may possibly be useful as a means to better determine optimal signal processing parameters for individual patients, and/or to better understand in general neural system responses to signal processing algorithms to assist in the development of more effective approaches.

When measuring AEPs in cochlear implant patients, one factor that must be considered is that the electrical stimulation can produce an electrical stimulus artifact that distorts or masks the neural response. This has been one of the reasons that electrically evoked APs can be difficult to measure (and are seldom used in cochlear implant research) since the duration of the electrical stimulus artifact is in the same time frame as the measured response. In order to record electrical AP responses, then, the stimulus artifact must be subtracted. This can be accomplished by a paradigm that takes advantage of the refractory properties of nerves (e.g. Hay-McCutcheon *et al.*, 2002). First a probe signal is presented and the resulting recording contains both the neural response and the stimulus artifact. Then a masker and probe signal are presented where the probe signal closely follows the masker. In this case the nerve is unable to fire in response to the probe since it has just fired in response to the masker. The probe response with masker is subtracted from the probe-only response, leaving the activity related to the neural response. The electrically evoked ABR is easier to measure without stimulus artifact contamination since there is usually about 2 ms between

the stimulus and the onset of recording. Another approach used clinically to reduce stimulus artifact with the ABR is to use stimuli that alternate between initial positive going and initial negative going polarity so that the electrical artifact, which mimics the polarity of the stimulus, is averaged out in the response. Electrical artifact is not an issue in longer-latency responses elicited by a short stimulus, but can be if a longer duration stimulus is used.

The convention in this area is to label some of the shorter latency potentials elicited via cochlear implant stimulation with an “E” to indicate that they are electrically rather than acoustically evoked. For instance, the acoustic ABR is commonly referred to as an EABR when measured in a cochlear implant patient with electrical stimulus presentation via the implant. However, some of the higher level AEPs like the P300 are not commonly designated with an “E” prefix in the research literature<sup>2</sup>. In the remainder of this paper, it can be assumed that whether or not the “E” prefix is attached, subject responses described were electrically evoked via a cochlear implant, and any normal control responses elicited with acoustical stimulation.

The following reviews the literature on research using AEPs to evaluate cochlear implant subjects is explored. An attempt was made to focus on some key studies that appeared to use a somewhat better research design or a unique

---

<sup>2</sup> As shown in the overview of the family of AEPs, terminology in the human auditory evoked response field is quite variable and there are unfortunately no widely agreed-upon conventions for naming of either acoustically evoked or electrically evoked potentials.

measurement technique, greater numbers of subjects, or better matched subjects in this highly heterogeneous population.

### *Short and Middle Latency Evoked Potentials and Cochlear Implants*

Quite a few studies in the AEP literature evaluating the functioning of cochlear implants have used the ABR for the same reasons it is often applied in clinical applications - - its robustness and early maturation. Some studies reviewed herein also looked at the earlier latency AP, and a few have examined the higher-level MLR.

Firszt *et al.* (1999) obtained EABRs intraoperatively from three children (aged 2 to 3 years) who were receiving cochlear implants, and EABRs and EMLRs in the clinic from three adult cochlear implant subjects (aged 29 to 54 years). The stimulus presented was a broad spectrum signal spanning the subjects' full frequency range of hearing. Each subject's electrical dynamic range (range from hearing threshold to uncomfortable loudness level) was also mapped with behavioral measurements. Results revealed that EABR thresholds were within the behaviorally measured dynamic range for 2 of the 3 adults and 2 of the three children. For the other adult and child, the EABR was either unmeasurable or exceeded the upper limits of comfortable loudness. For this adult, the EMLR was also either absent or of poor morphology. Interestingly, the latter adult was the poorest performer with his cochlear implant, with an inability to understand open-set (auditory only) speech. Comparison of performance to AEPs suggested

that the best performers produced the best AEPs and the poorest performers produced the poorest AEPs.

Hay-McCutcheon *et al.* (2002) evaluated both the electrically-evoked action potential (EAP) and the electrically evoked ABR (EABR) in cochlear implant recipients. Subjects were 10 post-lingually (after speech and language development) deafened adults wearing the Nucleus 24 cochlear implant. Prior to testing, behavioral thresholds (Ts) and maximum comfort levels (Cs) with the cochlear implant were measured using standard clinical practice techniques. Then electrophysiological threshold measurements were obtained with both the EAP and EABR to determine the lowest stimulus level at which a replicable response could be obtained. Results indicated that the AEP thresholds were closely correlated with the behaviorally measured thresholds.

In another study, Firszt *et al.* (2002) obtained electrical ABRs and MLRs from 11 adult users of Clarion cochlear implants. Their intention was to develop normative reference values for the expected latencies, amplitudes, and thresholds for typical adult implant users across electrode sites on an intra-cochlear electrode array. They reported that, for the EABR, Wave V latency was significantly longer for the implanted basal electrode (#7) compared with the mid (#4) and apical (#1) electrodes. In contrast, for the EMLR, there were no significant differences in latencies by electrode across the implanted array. Amplitudes were highest for the apical electrode and lowest for the basal electrode across both the EABR and EMLR. Finally, EABR and EMLR thresholds were significantly

lower for the apical electrode than for the basal electrode. Examples of EABRs recorded from one subject in this study for the three intracochlear electrode sites are shown in Figure 9 below.

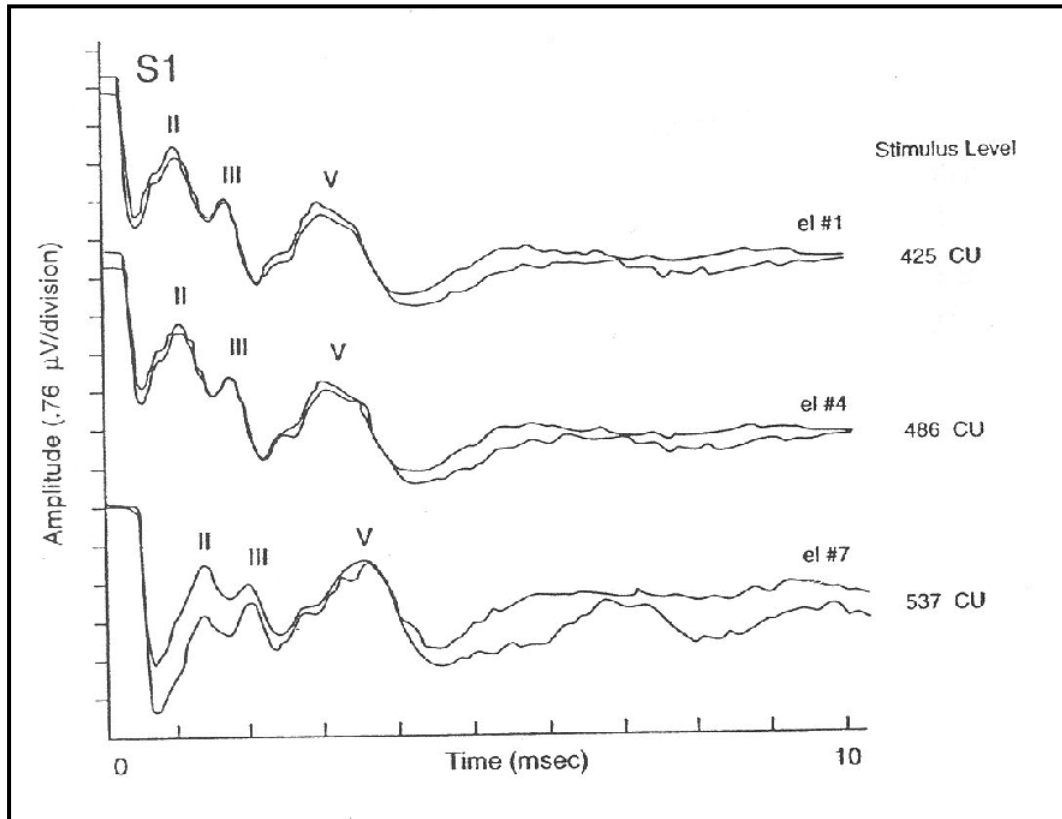

Figure 9. EABRs recorded from one cochlear implant recipient from three different electrodes in the intracochlear array. (From Firzt *et al.*, 2002).

In the last few years, due to the success of unilateral (one ear) implantation, some patients have received bilateral (both ears) cochlear implants. In 2002, Thai-Van and colleagues evaluated two case studies of subjects who had bilateral implants to see if duration of deafness prior to implantation affected the



EABR. These French subjects were wearing the MXM Binaural Digisonic Convex system, a device in which electrode arrays placed bilaterally were controlled by a single processor. In both subjects, there was a differing duration of deafness prior to implantation between the two ears. For both subjects, EABR Wave V latency was found to be longer in the ear that had the greater duration of deafness.

Gordon *et al.* (2003) evaluated plasticity of the auditory nervous system by measuring both electrically evoked APs and ABRs repeatedly over a one year period in 50 children who had just received Nucleus cochlear implants. All the children had pre-lingual (before speech and language development; usually congenital) severe to profound hearing loss, and subsequently were implanted at ages ranging from 1 year to 17 years old. Both EAPs and EABRs were evoked with a full complement of peaks immediately after activation of the cochlear implants, but over the following year, latencies of the peaks significantly decreased and amplitudes significantly increased. The authors proposed that the underlying mechanism may be improvements in synaptic efficacy or even increased myelination due to the stimulation of the neural pathways. Due to the fact that the improved AEPs were not correlated with duration of deafness of the children in this study, these authors concluded that developmental plasticity at least of the auditory brainstem did not appear to be limited only to early childhood.

More recently, Gordon *et al.* (2008) evaluated EABRs in three groups of children, all of whom had been implanted at younger than 3 years old. One group of subjects had simultaneously received bilateral implants (n = 15), a second group had received their second ear implant after a short inter-surgery interval (< 1 yr; n = 15) and the third group had received their second ear implant after a long inter-surgery interval (> 2 yrs; n = 16). The EABRs were recorded right after the children received bilateral implants, and 3- and 9-months later. Results revealed no differences in EABRs between ears in the children receiving simultaneous implants. However, for sequentially implanted children, ears implanted at a later date showed longer latencies than the first implanted ears. The differences decreased over time until there was little difference in the short inter-surgery interval group, but differences persisted in the long inter-surgery interval group suggesting effects of auditory deprivation.

Gibson *et al.* (2009) evaluated 245 children receiving Nucleus implants, and compared presence or absence of Waves II-V of the EABR obtained intraoperatively to speech perception performance after 1 year of implant use. Results indicated a strong relationship between good EABR morphology and good speech recognition scores. After 2 years of implant use, 148 children's speech recognition was re-evaluated and the relationship between good EABR morphology intraoperatively and continued speech recognition improvement was even stronger.

### *Late Latency Evoked Potentials and Cochlear Implants*

In the Firzt *et al.* (2002) study previously described that had evaluated EABRs and EMLRs, LLRs were also recorded in the 11 adult implant users. Results were consistent with those for the EMLRs in terms of effect of intracochlear electrode location on latencies, amplitudes, and thresholds of N1-P2.

Sharma and colleagues have written several papers utilizing the LLR in measurements with cochlear implant subjects. In 2002a, Sharma *et al.* evaluated the plasticity of the central auditory pathways following cochlear implantation. They measured the LLR in congenitally deaf children (age range = 1 to 5 1/2 years) after implantation. Although a within-subject design would have been optimal, this study chose a between-subjects design by dividing the children into groups according to how long they had been stimulated with their cochlear implant. Specifically, 5 children had been stimulated for about 1 week, 5 children for about 2 months, 6 children for about 5 months, and 6 children for about 8 months. The LLRs were produced with the synthesized speech syllable /ba/ (pronounced “bah”). The children with little experience with their implant (mean 1 week stimulation) showed LLRs with morphology and latencies that were consistent with what would be seen in normal hearing newborns. Over months of cochlear implant use, however, the LLR latencies decreased rapidly so that by 8 months post-stimulation the children showed latencies that approximated age-appropriate norms. Figure 7 shows waveforms for the children in this study who

had from 1 week to 8 months post-stimulation wearing time with their cochlear implants.

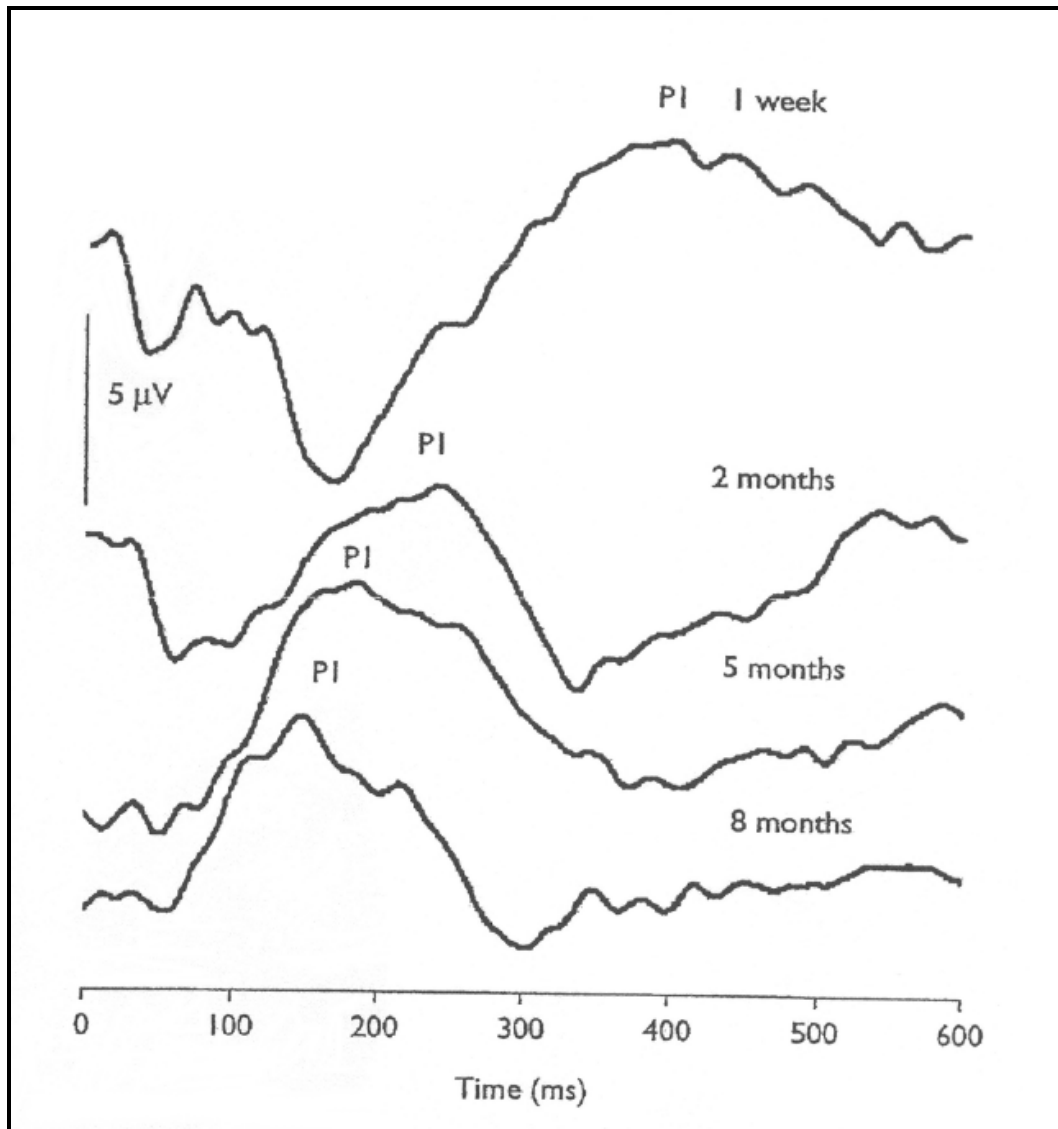

Figure 10. Grand average LLRs for the four groups of children, illustrating latency decreases with increasing cochlear implant experience. (From Sharma *et al.*, 2002).

In a more extensive study that same year, Sharma *et al.* (2002b) examined LLR responses in 104 congenitally deaf children ranging in age from 1.3 years old to 17.5 years old, and three congenitally deaf adults (aged 20 to 35). All had worn cochlear implants for at least 6 months. Duration of deafness before implantation was the independent variable in the study, and P1 latencies to the speech stimulus /ba/ were compared to age-matched normal hearing peers. It is of note that in about 12% of the original subject group, P1 was obscured by electrical artifact and these subjects were excluded from the study. The remaining subjects were divided into three groups: The early-implanted group consisted of children implanted by aged 3.5 years old, the middle-implanted group consisted of children implanted between the ages of 3.6 and 6.5 years old, and the late-implanted group consisted of children implanted after 7 years of age. The last group also included the adults, who had been implanted at ages ranging from 18 to 34. In comparison to normal age-matched controls, results indicated that P1 latencies for the early-implanted group were age-appropriate. The P1 latencies were, however, abnormally long for the late-implanted group, and also for about two-thirds of the subjects in the middle-implanted group. The authors concluded that, in the absence of normal stimulation after birth, there is about a 3.5 year period of neural plasticity. They also believed that for some children, but not all, good plasticity remains up to about age 7, but is sharply reduced thereafter. A potential confounding factor in this study was that some of the middle- and late-implanted subjects may have done better than others because they received partial

stimulation from high-power hearing aids for a number of years prior to implantation. Nevertheless, this finding is consistent with the known fact that duration of deafness is a significant predictor of subsequent speech recognition performance with cochlear implants, and argues for early intervention with cochlear implants for deaf children. Sharma *et al.*'s 2004 study also showed that infants early implanted show a rapid reduction in LLR latency over 3 months post-surgery that corresponded to a clear increase in the number of canonical (speech-like) babbling utterances as opposed to pre-canonical utterances.

#### *Endogenous Potentials and Cochlear Implants*

There has been more limited research on endogenous potentials as related to cochlear implants compared to that with exogenous potentials.

#### **P300 Research**

Of the endogenous potentials, the P300 has been studied the most in cochlear implant subjects. Jordan *et al.* (1997) reported on measurements of the P300 in five adult (ages 16 to 49) recipients of cochlear implants. Three of these subjects had been pre-lingually deafened and two had been post-lingually deafened. The subjects were evaluated over a 6 month period of auditory rehabilitation training after implantation, in monthly follow-up sessions. The subjects were given a simple task of the detection of a 400 Hz and a 1450 Hz tone, with one of the tones presented as the “deviant” (rarer in presentation

frequency). These authors reported that, over time, the latency of the N400 component of the LLR was shortened (a negative peak that occurs at about 400 msec), indicating improved ability of the auditory system to process the input from the cochlear implant. However, it was noted that this effect was weaker in the prelingually deafened subjects than in the postlingually deafened subjects. Also, 3 of the 5 subjects showed an endogenous P300 component from the deviant measurement paradigm. The two subjects who failed to have a P300 elicited even after 6 months of cochlear implant use were both prelingually deafened, suggesting that these subjects were unable to differentiate the frequency differences between the disparate tones when using their cochlear implants. Results from all five subjects and a normal hearing control are shown in Figure 11. The results appear to illustrate that the pre-lingual brain may never be able to learn some tasks when finally stimulated, while the post-lingual brain can re-learn to use the newly processed sound to perform a task that was previously learned with similar auditory stimuli.

Several other early studies similarly using tonal stimuli for P300 measurements in cochlear implant recipients. For instance, Oviatt and Kileny (1991) found that the P300 latency was longer in adults with cochlear implants than in normal hearing adults when elicited by pure-tone pairs. Tone-evoked P300s have also been elicited in pediatric cochlear implant subjects (e.g. Kileny, 1991).

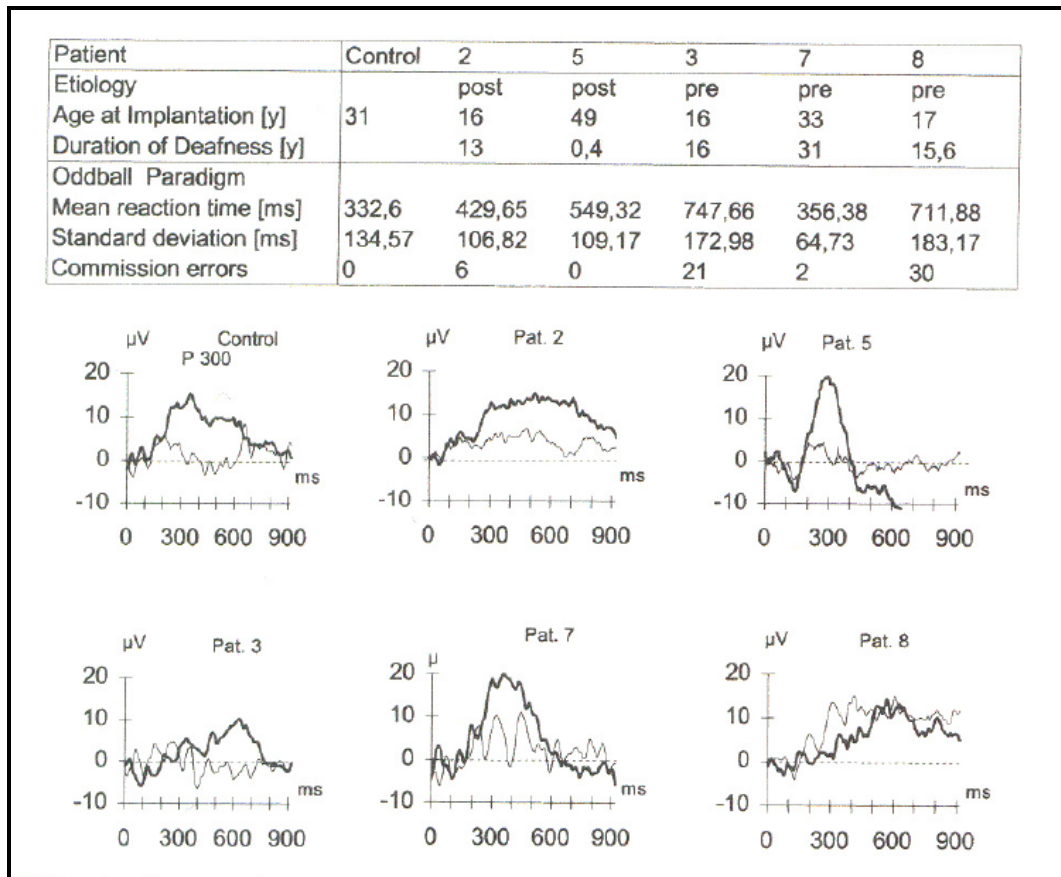

Figure 11. P300 waveforms from all 5 cochlear implant subjects and 1 normal hearing control. (From Jordan *et al.*, 1997).

Micco *et al.* (1995) measured the P300 in nine “successful” cochlear implant subjects (all were post-lingually deafened), and compared results to those from nine age-matched normal hearing controls (ranging in age from 38 to 81 years old). “Success” with the implants was based on subjective reports of everyday communication ability, and scores using a sentence-level, open-set speech perception test. One cochlear implant user who was considered unsuccessful or “poor” due to limited communication enhancement with their



implant was also tested. The “oddball paradigm” was used with the synthesized speech pair /da/ (pronounced “dah”) and /di/ (pronounced “dee”). Results revealed that the N1 and P2 potentials of the exogenous LLR were similar across the matched subjects in latency although the N1 amplitude was significantly smaller in the cochlear implant subjects than in the normal controls. The P300 was not elicited in the one “poor” cochlear implant subject at all. The P300 elicited in the “successful” users, however, showed no significant differences in either latency or amplitude from the normal control group. Representative results are shown in Figure 12. Other researchers have also shown that the P300 can be generated in cochlear implant subjects with the use of speech stimuli (Kaga & Kodera, 1999; Groenen et al., 2001).

Muhler *et al.* (2004) noted that, unique to the application with cochlear implant subjects, the stimuli used to elicit the P300 is modified by the signal processing of the implant. Therefore, they felt that better knowledge of the stimulation pattern is essential to understanding the responses. These researchers evaluated tone-evoked P300 responses in cochlear implant subjects who were using the Med-El Combi 40+ multichannel cochlear implant (which is more widely used in Europe than in the U.S.). The frequencies of the tone bursts used were chosen such that they were presented on specific electrodes after the signal processing of the cochlear implant. They also calculated “stimulograms” to visualize these stimulation patterns. These were color-coded plots of the charge of each stimulus pulse as a function of time and stimulation channel. The

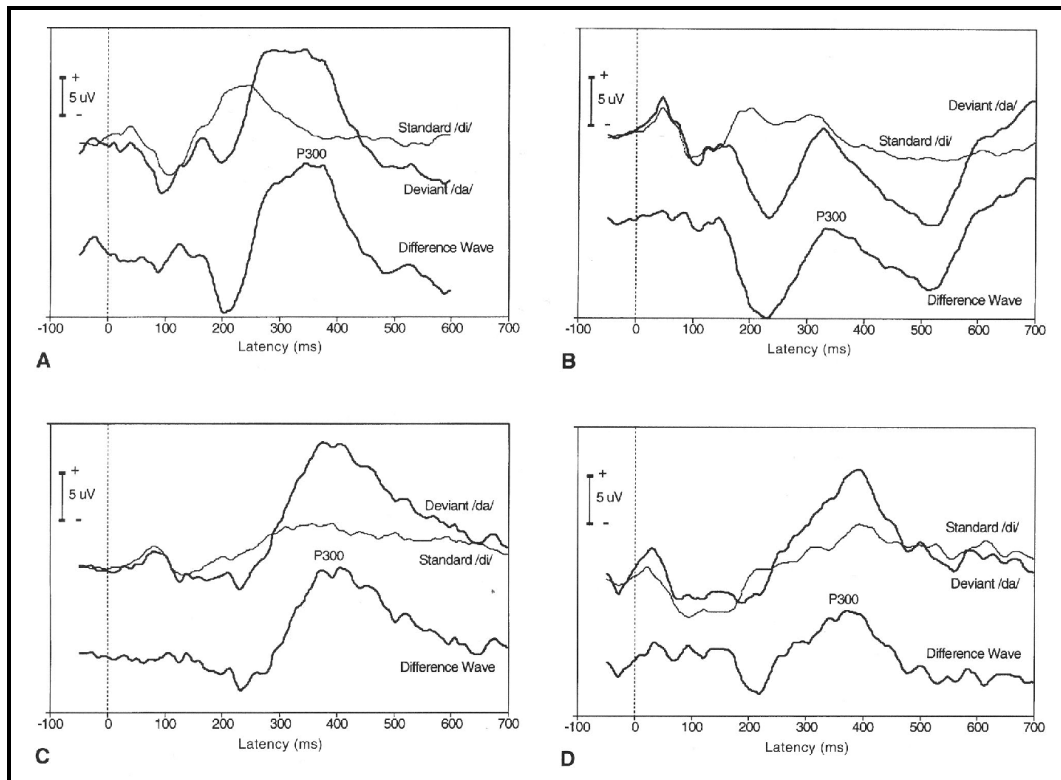

Figure 12. Representative P300 responses from 4 cochlear implant recipients to the common stimulus /di/ and the odd stimulus /da/. Also shown are the difference waveforms. (From Micco *et al.*, 1995).

algorithm used in the cochlear implant processing was implemented exactly by using a MATLAB program to ensure that the color-coded plots represented the true stimulation pattern at the electrode level. The purpose of the study was to examine the effects of stimulation patterns on the AEP. Interestingly, these authors demonstrated the effects of electrode separation on the P300 in two case examples of postlingually deafened adults and showed that the deviant stimuli must be presented on a different electrode than the standard stimuli in order for the subject to discern a difference, and thereby elicit a P300 response. Shown in

Figure 13 is one subject's responses elicited by stimulus contrasts of increasing difficulty.

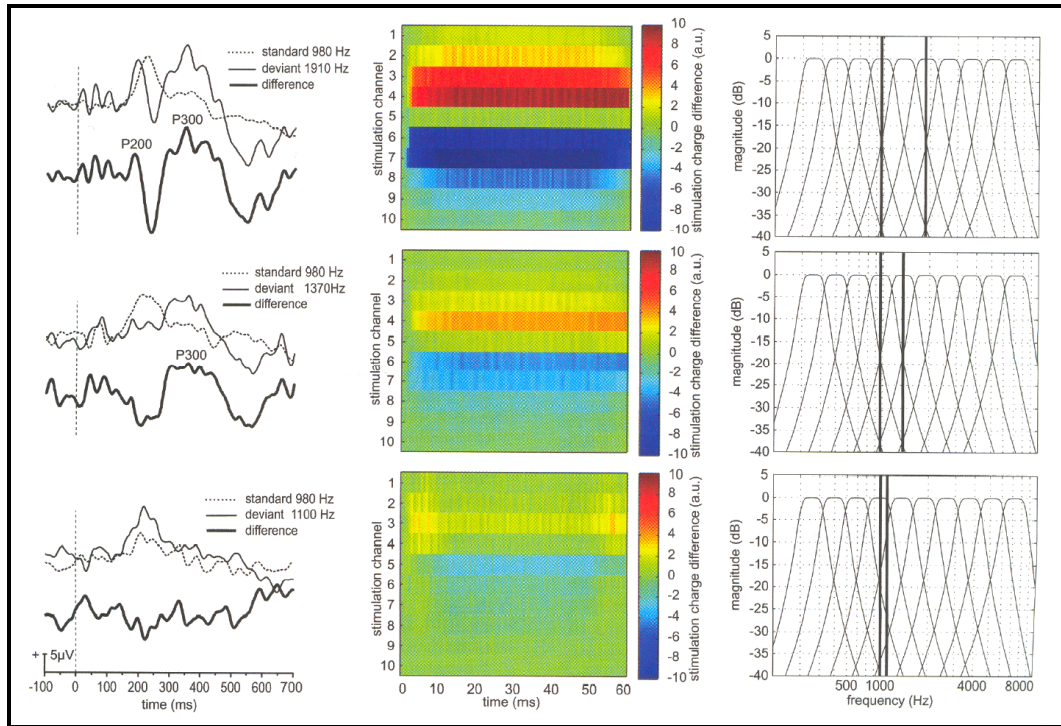

Figure 13. P300s elicited by stimulus contrasts of increasing difficulty in one cochlear implant patient (left column). Difference-stimulograms calculated for these (middle column). Transfer functions of bandpass filters implemented in the CIS speech processing algorithm of the cochlear implant – bold lines indicate the frequencies of the standard and deviant tone bursts stimulating adjacent implant electrodes (right column). (From Muhler *et al.*, 2004).

## MMN Research

More limited work has been done applying the MMN to cochlear implant research. One early study was that by Kraus *et al.*, 1993, who demonstrated that the MMN elicited by synthetic speech stimuli (with well-defined acoustic

differences) were similar in experienced, successful cochlear implant users to those from normal hearing users.

Okusa *et al.* (1999) evaluated both the standard P300 endogenous potential using a two-tone oddball discrimination task, and also the MMN and a later trough in the LLR response called the “N2b” or N200. The latter two potentials (MMN and N2b) are thought to be related and only appear on the difference waveforms between the standard and deviant stimuli recording bins. The MMN was described as a gradually increasing ramp-like small negativity, starting at about 100-120 ms and showing the negative N2b trough at about 250-300 ms. As expected, the latency of the P300 in eight cochlear-implant recipients increased as task difficulty increased (two stimuli closer in frequency). The N2B trough also increased as the task difficulty increased, and the MMN showed a slight delay at the smallest of the contrasts, while the standard earlier peaks and troughs of the exogenous LLR did not. Finally, the amplitude of the N2B trough was reported to be almost twice that for normal ears. The researchers suggested that N2B is associated with the effort it takes to process the discrimination task, and that this effort is greater for cochlear implant subjects than for normal hearing subjects.

Singh *et al.* (2004) evaluated whether MMN and the exogenous peaks and troughs of the LLR could be used to categorize cochlear implant subjects into “good” versus “poor” performers. They used an oddball paradigm with speech stimuli presented in pseudorandom order to 35 young cochlear implant users

between the ages of 7 and 17 years old. They compared the latencies and amplitudes of the AEPs with overall behavioral outcome of the cochlear implant as measured by speech intelligibility and auditory performance rating scores. Results indicated that none of the subjects had an N1 component (below the age of 10, an adult-like N1 is not measurable), but 30 of the 35 had P1 and N2 exogenous responses. P1 showed a statistically significant reduction in latency with increasing duration of implant use in prelingually deaf subjects. The MMN was recorded in over 80% of the so-called “star” subjects (best performers) but only in less than 20% of subjects categorized as “poor” performers. Subjects with higher speech intelligibility rating scores had longer duration MMN (a better outcome for this AEP) than those with lower speech intelligibility rating scores (Pearson  $r = 0.74$ ;  $p = .01$ ). The authors reported, then, that the MMN was able to successfully differentiate functional performance of children with cochlear implants.

This review of the research literature has shown that AEP assessment of cochlear implant performance has merit. However, it is evident that there are still numerous opportunities for the development of advanced equipment and techniques for better AEP measurements in cochlear implant recipients. Although there has been a recent increase in the amount of research done using AEPs with cochlear implant subjects, much more work remains to be done before a full understanding will be achieved.

The instrumentation and techniques to measure AEPs in cochlear implant recipients are also still not very well refined, nor are the analysis approaches. Commercial auditory evoked potential instrumentation typically will only measure up to 4 channels for basic exogenous potential measures with click or simple tonal stimuli. Most of the more sophisticated measurements have been done with component-based laboratory equipment. At present, in electrically-evoked AEPs, some of the studies use acoustic inputs to the signal processing unit of the cochlear implant, and some use direct electrical inputs. What differences this may produce in the results is not clear, and sometimes the manner of stimulus presentation is not even stated. As shown in the Muhler *et al.* (2004) study, it is important to consider how the signal processing approach used in a particular cochlear implant may affect the resulting ability to measure the AEP. With new signal processing approaches on the horizon by the major cochlear implant manufacturers, this may become even more important. Thus, more work is needed to be able to better couple the measurements with the unique aspects of stimulating, and measuring in, cochlear implant subjects.

Cochlear implant subjects show a relatively broad range of levels of speech perception abilities post-implantation, and some of the interest in applying both exogenous and endogenous AEPs to the study of these subjects is to see if there is correspondence between these physiological measures of auditory perception and the subject's functional success with an implant. One interesting idea is the possibility of electrically stimulating a subject prior to cochlear

implantation for measurement of an exogenous or endogenous potential as a form of predictor regarding subsequent speech perception success with implantation. Another area of potential research is in using measurements of exogenous and endogenous AEPs in rehabilitation of the subject, i.e. the form that rehabilitation should take may be predictable from such measurements or may be modified depending on the outcome seen over time. The use of AEPs to set current levels and signal processing parameters appropriately for infants and young children who have limited capability to provide behavioral feedback is a topic currently being explored in some laboratories.

Of most relevance to the current study is the use of these objective measurements in better understanding what form signal processing in cochlear implants should take in future. Because of its common usage and ease in measurement, this thesis focused on the EABR, but the work reported herein could in future be expanded to other components in the family of AEPs as well.

### **Frequency Specificity and the EABR**

It is notable that published EABR work to date has almost exclusively used monopolar or wide bipolar stimulation of cochlear implant electrode arrays. Monopolar stimulation refers to the condition where any of the intracochlear electrodes is used as the active electrode and an extracochlear (outside of the cochlea) electrode is used as the return electrode in measurement. Wide bipolar stimulation refers to the condition where both the active and return electrodes are

intracochlear, but are spaced relatively widely apart from each other to stimulate across a broader frequency range. As a consequence, neither approach provides much specificity for the sites (place) of stimulation in the cochlea that correspond to pitch perception.

In the Cochlear Ltd. Nucleus cochlear implant, there are 22 banded electrodes in the implanted electrode array as illustrated in Figure 14. These are numbered E22 (at the tip of the array, inserted most deeply into the cochlea) down to E1 (at the base of the array). The basal electrodes tend to elicit hearing sensation at higher frequencies, corresponding to high-pitch perception, while the apical electrodes tend to elicit a lower-frequency broadband hearing sensation, or low-pitch perception.

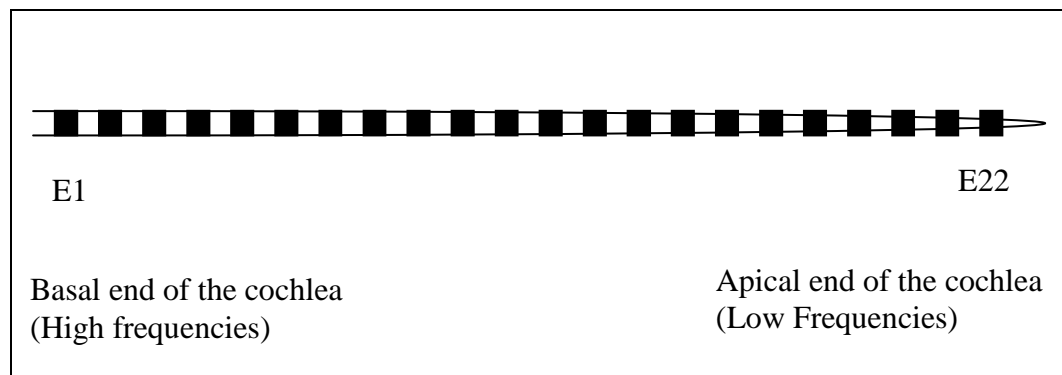

Figure 14. Schematic illustration of Cochlear Ltd Nucleus implant electrode array, which would be inserted and coiled into the cochlear partition. There are 22 electrodes, numbered starting with E1 furthest from the tip, to E22 near the tip of the array.

In acoustic ABR measurements, it is known that the primary neural responsivity when a broadband click stimulus is used is from the frequency region



2000 to 4000 Hz, with lesser responsivity at higher and lower frequencies of stimulation. The electrode array in a Nucleus implant is intended to encompass, ideally, a full frequency range of stimulation from about 250 Hz to about 8000 Hz although not all individual patients receive such a wide bandwidth. Also, sometimes individual electrodes in the array cannot be used due to such factors as lack of perception from that electrode, stimulus overlap problems, or stimulation of the facial nerve or vestibular system. In general, however, it is anticipated that electrodes nearer the base of the electrode array than the apex will mediate the 2000 to 4000 Hz range that is thought to be most responsive in acoustic ABR measurements. This is illustrated in Figure 15, which shows what is commonly referred to as “the Greenwood map” (Greenwood, 1990).

No published studies were identified that collected EABR data using more frequency specific stimulation sites; i.e. all used monopolar or wide bipolar stimulation mode. This information might be useful in providing insight into differential sensitivity across more narrowly spaced electrode regions. Therefore, one aspect of the current study was to evaluate a novel recording technique to elicit EABR recordings using narrow bipolar stimulation from intracochlear stimulation in implant patients using Nucleus devices. These data were evaluated for viability of the recording technique, variations across place in the cochlear

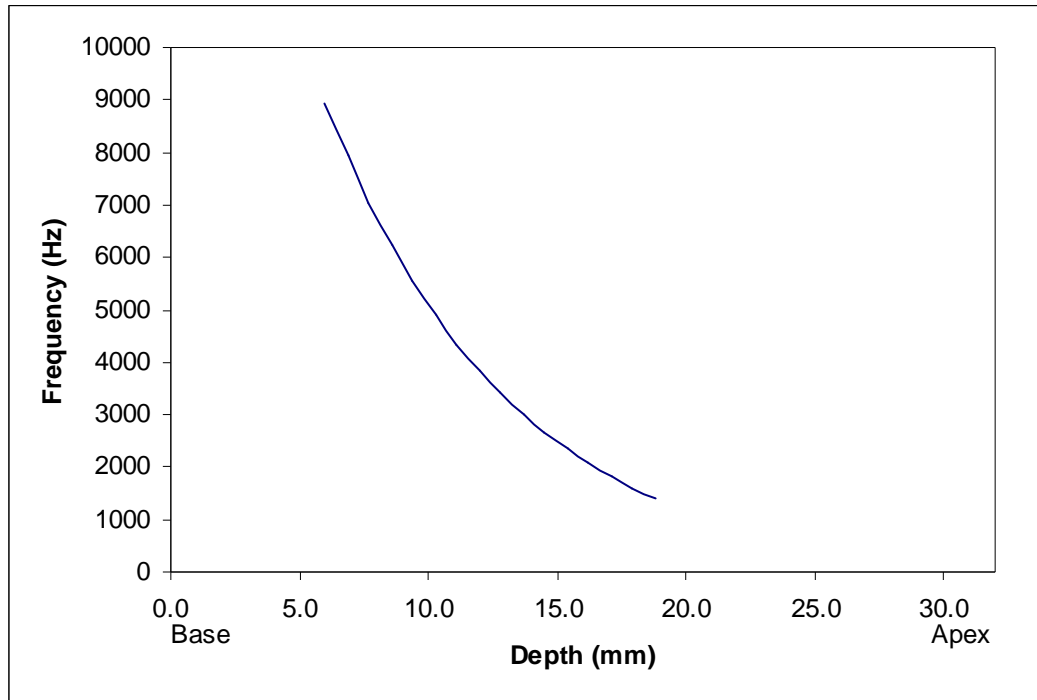

Figure 15. Greenwood frequency map (From Roland *et al.*, 2004). The points for a 22 electrode array can be loosely interpolated along the map. In a 22 electrode array, electrode E1 is generally inserted to approximately 4.0 mm. The apex of the cochlea extends to about 32.0 mm in an adult human. Since a standard 22-electrode array is approximately 18.0 mm in length, electrode E22 is inserted to approximately 22.0 mm in the cochlea.

partition, and to serve as a basis for analysis of a model developed to simulate EABRs. Specifically, for the EABR measurements collected for this study, electrodes in the intracochlear array that were one electrode apart were used in pairs to stimulate very narrow regions of the cochlear partition to elicit the electrophysiological response.

## Computer Modeling of AEPs

Some work has been conducted on modeling both acoustically or electrically evoked AEPs, but it has been limited and there are many areas yet to explore. In some cases this research has been conducted in order to better understand how the auditory nervous system works, while some of the work was intended to develop models to aid in the optimization of evoked potential recording or to add new functionality. For example, Abbas *et al.* (1999) created some fairly extensive models under an NIH contract during the latter half of the 1990s. These auditory evoked potential models focused primarily on single unit scenarios; That is, modeling the action potential of a single nerve fiber as it fires in response to electrical stimulation. Their primary aim was to better understand the fundamental aspects of electrical stimulation of the auditory system, and not necessarily to assist in future development of better implants.

Fobel (2003) conducted work in the area of modeling acoustically evoked AEPs, and some of the results of his work have been used in the current simulation project. Fobel's work concentrated on exploring the various characteristics of the acoustic middle latency response (MLR), in order to model it. The MLR occurs at a next higher level in the auditory nervous system than the ABR, and is not as commonly used in clinical and research applications because it is more variable across normal ears and often more difficult to measure. Since the ABR occurs within the first 10 ms of the longer MLR response, however,

information about the earlier potential can be extracted from Fobel's work. The goal of Fobel's work was to create an accurate model that could be used to assess different types of acoustic stimuli used to elicit auditory evoked potentials, in order to optimize stimulus parameters.

The primary goal of the current research project was to develop a model for EABR recordings in cochlear implant subjects, which had not previously been done even though the ABR is more commonly measured in implant recipients. The work of Fobel (2003) was used as a basis for the model, with extraction of the ABR region information, and adaptation for application to measurements with electrical stimulation in cochlear implant recipients. For this thesis, a MatLab model is shown that was developed based on Fobel's published model for acoustic stimulation of normal ears (Fobel, 2003) and also based on published EABRs from several studies (Abbas *et al.*, 1999; Cai *et al.*, 1998; Hay-McCutcheon *et al.*, 2002). The input to the model was the stimulus current intensity level. A function vector representing combined firing of auditory neurons, and equations derived from measured ABRs representing latency and amplitude scaling functions, were used to generate a response approximation. The simulation also reduced contamination from other neural activity via time-locked averaging. Finally, EABR data collected on patients with Nucleus cochlear implants, and using the novel measurement technique that was intended to obtain more frequency-specific results, were compared to predicted waveforms from the model to evaluate its accuracy.

## CHAPTER 3

### EXPERIMENTAL METHODS

#### **Measurement of EABRs in Cochlear Implant Recipients**

##### *Subjects*

Subjects for measurement of EABRs were six adult cochlear implant users. Measurements were made on a total of 8 ears, because two of the six users had bilateral cochlear implants (one in each ear) so that EABRs could be collected for both right and left side stimulation. All subjects had Cochlear Ltd. Nucleus cochlear implant models, were considered successful users because they were relatively high performing in terms of open-set (no visual cues) speech recognition scores, used their implant(s) daily, and had at least 1 year experience with their implant(s). Some demographic information about the subjects and their implants is shown in Table 1.

##### *Instrumentation and Procedures*

For collection of the EABRs in this study, a commercial acoustic ABR recording system was used. However, because no commercial equipment is configured for electrical ABR (EABR) recording, it was necessary to interface the

Table 1. Demographics and Cochlear Implant Information for the Subjects Used in EABR Measurements.

Subject No.	Age	Gender	Ear(s) and Model(s) of Nucleus Implants	Signal Processing Algorithm
1	56	F	CI22M	SPEAK
2	32	F	Right – CI24R Left – CI24M	ACE ACE
3	70	M	CI24R	ACE
4	77	M	CI24M	ACE
5	26	M	Right – CI24R Left – CI24R	ACE
6	40	M	CI24R	ACE

cochlear implant equipment with the ABR recording equipment in a manner that would allow measurement of EABRs. The ABR recording equipment used was the Navigator EP System by Bio-logic Systems Corporation, and the cochlear implant equipment used was the SPrint™ signal processor by Cochlear Ltd for use with Nucleus series implants.

The commercial ABR equipment normally is used to produce an acoustic signal, which is delivered to the ear through earphones. The recording amplifiers are triggered at the same time that the acoustic stimulus is delivered. Since an acoustic stimulus generator is not used for EABR recording, in this study the

control computer was modified to command the cochlear implant processor to deliver stimuli and to simultaneously trigger the signal averager to capture the EEG signals. The EEG was recorded from surface (scalp) electrodes, across a specified time window starting at each stimulus pulse.

For the EABR recordings in this study, the commercial equipment was set up with recording parameters comparable to those typically used for acoustic ABRs. Specifically, the time frame for measurement was 10 msec following stimulus presentation, the stimulus repetition rate was 30 per second, 1000 stimuli were averaged per recording, and bandpass filtering of the incoming EEG was set at 100 to 3000 Hz. For the differential amplifier input, the active electrode was placed at the high forehead (or “Fz”, according to the International 10-20 electrode convention), the reference electrode was placed over the mastoid bone (behind the ear) of the implanted ear under test, and the ground electrode was placed at the opposite (contralateral) mastoid. Disposable adhesive disc electrodes were used and attached following cleansing and mild abrading of the skin. Impedance of the electrode to skin interface was  $< 2$  kohms at all three electrodes.

The stimulus produced by the cochlear implant was an electrical pulse, and therefore it was also picked up by the recording amplifiers. As a result, it was necessary to block recording for a few hundred microseconds following the stimulus so that it would not produce an artifact that would obscure the recording of the electrophysiological response. This is seen as the flat line at the beginning

of the recordings. This approach allowed retention in many cases of an identifiable Wave I, avoiding a problem often seen in previous EABR recordings in the literature. In addition, the electrode montage (locations) that was selected were intended to enhance the ability to obtain an identifiable Wave I.

The electrical stimuli delivered for the EABR recordings were pulses of 100  $\mu$ sec pulsewidth, and amplitude levels were varied for each patient between their behaviorally measured threshold of hearing and a level that they reported to be loud, but still comfortable (not reaching the level of uncomfortable loudness). Thresholds (referred to in the cochlear implant field as “T-levels”) and “loud comfortable” levels (referred to as “C-levels”) were determined via standard clinical measurement procedures for each of twenty narrow bipolar electrode pairs. These electrode pairs were configured in what is known as BP+1 mode (BiPolar + 1). In BP+1 mode, the return electrode for each stimulating electrode is the active electrode plus two, i.e. pairs are E1 and E3, E2 and E4, E3 and E5, and so on, until up to E20 and E22.

For each subject, a series of EABRs were first recorded with a wide bipolar electrode pair (E11 and E22) ranging from T level to C level in increasing 10 unit steps (approximately 2.25 dB per step) to confirm whether or not the subject was able to produce reasonably good EABR waveforms using this standard recording technique. Then recordings were made for each narrow bipolar mode: i.e., twenty electrode pairs in BP+1 mode at C level in an attempt



to obtain more place, frequency-specific information than obtained in previous studies.

### *Analysis Technique*

EABR waveforms were analyzed according to standard clinical procedure. The presence or absence of a replicable and/or identifiable response (with the customary peaks) for each electrode pairing was first noted. Then, for elicited waveforms, the most easily identifiable peaks (I, III, and V) were marked for absolute latency (in msec) and peak-to-trough amplitude (in microvolts).

### **EABR Model**

This simulation was written to run in MatLab 7.0 due to the ease of realizing an algorithm in the MatLab environment. The MatLab code also generates a graphical output of the results so that predicted waveforms can be compared to measured waveforms. To better compare the results, however, the data were imported into Microsoft Excel in order to graph the results from various stimulus intensity levels together, as is typically done when displaying ABR results.

The unitary response data developed by Fobel (2003) were used for the summated action potential (Figure 16). The term “unitary response” refers to the function vector that represents the summated action potentials of all the neurons in the auditory neural pathway. These data were acquired through deconvolution

of normative auditory brainstem response results obtained with acoustic stimulation. The current study has made the assumption that acoustically evoked response data provide a reasonable basis for simulation of electrically evoked ABRs because the neural processes are essentially the same in both cases. As will be shown later, this assumption appears to have been born out since the simulation responses appear to be similar in morphology, amplitudes, and latencies to measured electrically evoked responses.

The Fobel model does not take normal acoustic system nonlinearities into account, nor the impact of hearing impairment on residual numbers of available auditory nerve fibers, and thus some error in predicting the biological case is expected. Empirically, though, the error appeared to be relatively small in the Fobel model.

This particular model by Fobel characterizes the MLR, which is typically measured over 50 to 100 msec post-stimulation. For this simulation, however, only the early, ABR portion of the response, which is measured in the first 10 ms following stimulus presentation, was used because it is the evoked potential most commonly applied in cochlear implant patient measurements (primarily due to the fact that it is more reliable, better characterized in the research literature, and easier to measure than the MLR).

To incorporate the stimulus into the simulation, the charge applied to the neurons must be determined. For this simulation, a 25 microsec stimulus pulse, which is commonly used in cochlear implants, is assumed. Based on the

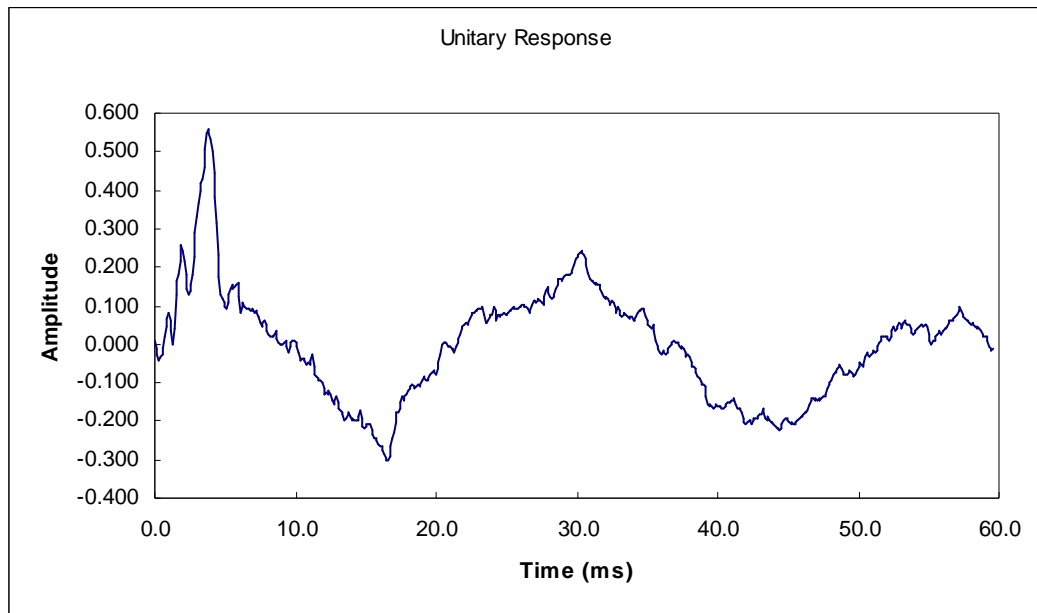

Figure 16. Unitary response derived through deconvolution of measured auditory brainstem response results (From Fobel, 2003).

assumption that the pulse width is fixed, the stimulus can be specified in units of current. In modern day cochlear implants, stimulus current is specified in units that are logarithmically related to the current in microamperes. This is directly correlated to the fact that sound pressure level used in acoustic stimulation is also specified on a logarithmic scale (decibels). The manufacturers of cochlear implants each use scales unique to their devices, as there is unfortunately no industry standard. For purposes of simplicity, only one scale (that from Cochlear Ltd. Nucleus devices) will be used throughout this simulation and analysis.

The stimulus level in the chosen scheme is referred to as Current Level, and is specified in 255 levels logarithmically spaced over the range of 10 microamperes to 2 milliamperes. Although there can be a great deal of variability

in the current levels delivered, those cochlear implant users that perform well typically have a threshold of hearing at a Current Level of approximately 140 to 160. A loud, but not uncomfortably loud (called “loud comfortable”), level is typically in the range of 200 to 220 in these patients.

Convolution of the stimulus with the unitary response produces the simulated ABR amplitude. However, waveform latency must still be taken into account. Published normative EABR results (Hay-McCutcheon, 2002) were used to arrive at an equation, through a best-fit method, to determine the waveform latency in the simulation. Waveform latencies are, however, shorter for cochlear implant users than for normal hearing subjects listening acoustically, due to the fact that the signal is injected directly at the nerve for the electrical input. This results in the absence of propagation time that is required for an acoustic signal to travel through the air of the ear canal, as a mechanical vibration through the ossicular chain of the middle ear, and as a fluidic wavefront that travels through the cochlear fluids. The simulation in the current study writes into the equation a function to account for the shorter latencies measured in cochlea implant patients. The difference between the latency for a cochlear implant, electrically evoked Wave V and that of a normal hearing subject stimulated acoustically can be observed by comparing the acoustic ABR in Figure 7 to the EABRs in Figure 9.

Other neural activity in the body can also be picked up in the ABR recording. This unwanted neural electrical activity consists of myogenic potentials (motor signals sent to muscles), other sensory system neural signals and

ongoing EEG brain activity, which will all be mixed with the auditory neural signals. However, since most of this other neural activity is uncorrelated in time with the auditory stimulus presentation, it can be reasonably represented as random noise. Averaging a large number of samples (typically 1000), thus allows the auditory signals to be extracted from the rest of the neural activity in the body. A particularly problematic noise source is that from the postauricular muscle (PAM) behind the ear, because twitching of this muscle can occur for some patients with a stimulus presentation and thus result in it also being time-locked to the stimulus presentation. It also occurs in the same time epoch and frequency range as ABR measurement. Commercial measuring equipment attempts to reduce PAM artifact in recordings by taking into consideration that it is much larger than the ABR response and does not typically occur with every stimulus presentation but only occasionally. Thus, any stimulus sweeps that are of excessive amplitude are not included in the final average because they are considered to likely include PAM activity.

The MatLab source code for the EABR simulation is included in Appendix A.

CHAPTER 4  
RESULTS AND ANALYSIS

**Measured EABRs**

Using the conventional wide bipolar stimulation mode, all eight ears of the six subjects produced replicable and identifiable waveforms showing at least a Wave V, although some subjects produced cleaner, better morphology waveforms than did others and some had more identifiable, replicable peaks. For the wideband stimuli, intensity functions were obtained for stimulus levels at or near “loud comfortable” (as judged by the subject) down to threshold intensity levels.

Representative samples of these wide bipolar EABRs obtained across stimulus intensity levels are shown in Figure 17. Subject 1 showed only a Wave V while Subject 2 showed a well-defined Wave I, III and V. As expected, the latency of Wave V tended to increase (although minimally for Subject 2), and the amplitude to decrease with decreased stimulus intensity level.

In contrast to the wide bipolar technique, usable EABRs were not reliably recorded when using narrow bipolar mode stimulation from all electrode pairings for all ears and subjects. In fact, despite being a successful cochlear implant user,

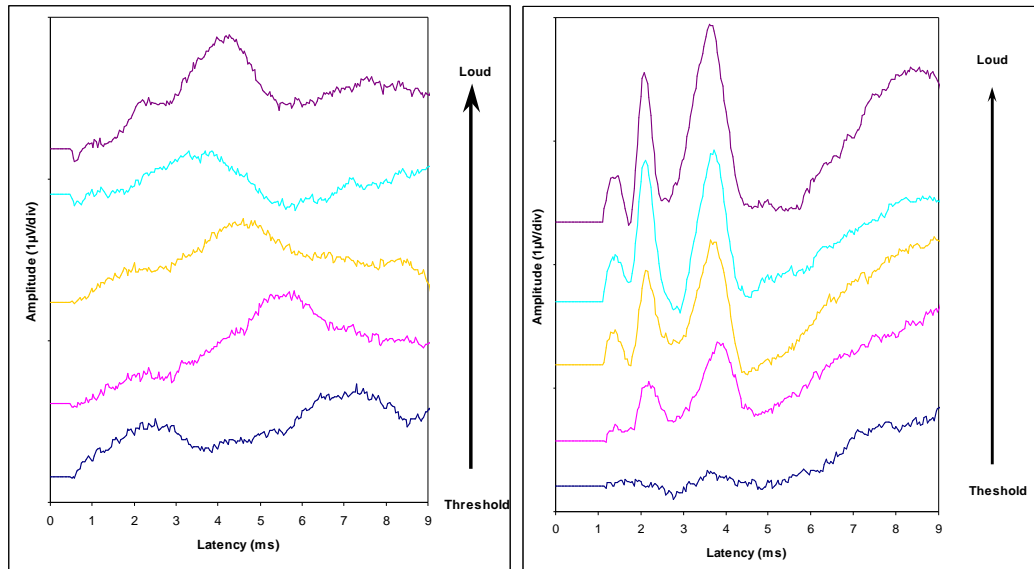

Figure 17. Wide bipolar stimulation EABRs from Subject 1 (left panel) and Subject 2, right ear (right panel), showing data across stimulus intensity levels from “loud comfortable” down to threshold level.

Subject 3 did not produce any replicable narrow bipolar EABRs at all, despite multiple attempts across two measurement sessions. In contrast, Subject 1 and both ears of Subject 2 produced good morphology EABRs across all sites of stimulation, showing clearly definable Waves I and III, a small Wave II for Subject 1, and small Wave Vs for both subjects. Subjects 4 and 6 produced only a weak and poor morphology Wave III across all electrode pairings, and Subject 5 produced a weak Wave III for one ear but no identifiable peaks for his other implanted ear. These narrow bipolar EABR recordings are shown across electrode pairings in Figures 18 through 21 for all the implanted ears. The waveforms toward the top of the series are from the apical pairs and the waveforms at the bottom are from basal electrode pairs. Stimulation level for

these recordings was either at “loud comfortable” level, or, in a number of cases, at the maximum output of the recording equipment, which did not always reach a judgment of “loud comfortable” for the patients.

The narrow bipolar stimulation results are of unique interest in terms of the frequency specificity of the measurement technique. To this end, amplitudes and latencies for all identifiable peaks for Waves I, III, and V across the six ears with measurable data are plotted in Figures 22 and 23. Means and standard deviations are shown in Figures 24 and 25. It can be seen that latencies are much less variable across subjects than are amplitudes, a finding not uncommon in electrophysiological research. In general, mean latencies and amplitudes appear to be fairly constant across the electrode pairing frequency range, and the best-fit latency lines fairly flat, although there are slight upward or downward trends in some instances. For some individual subjects, however, amplitudes for Waves III and V appear to be slightly larger and more clearly defined for apical electrodes (low frequencies) than for basal electrodes (high frequencies), while Wave I amplitudes appear to be more constant across the sites of stimulation.



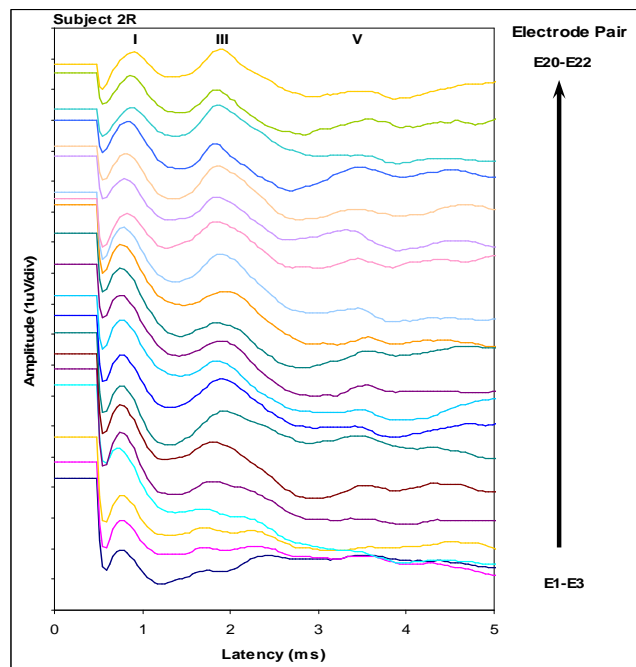
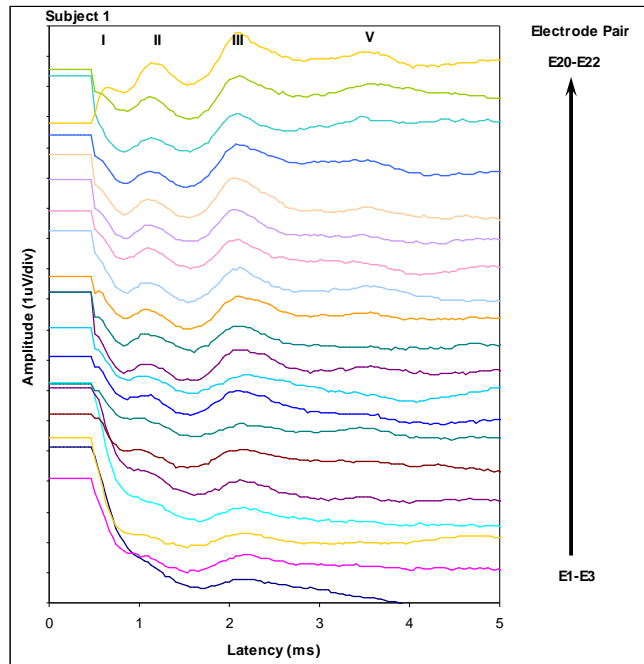

Figure 18. Narrow bipolar stimulation EABRs from Subject 1 (upper panel), and Subject 2, right ear (lower panel), showing data across the electrode pairings for stimulation at either maximum output or “loud comfort” level.

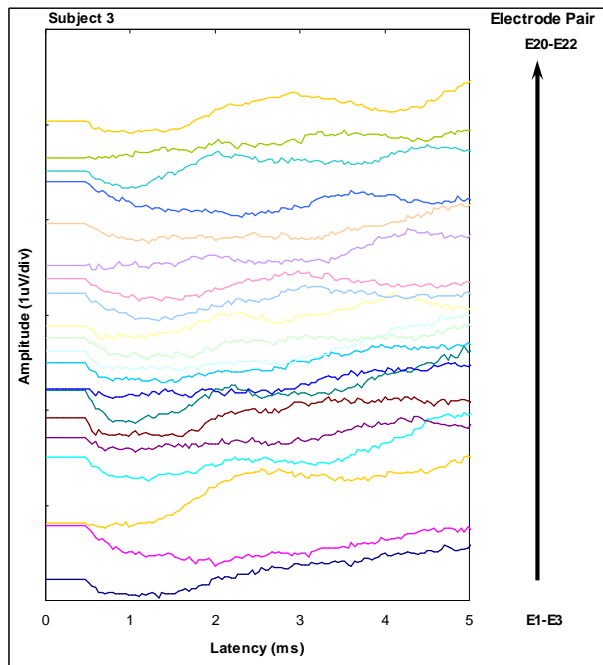
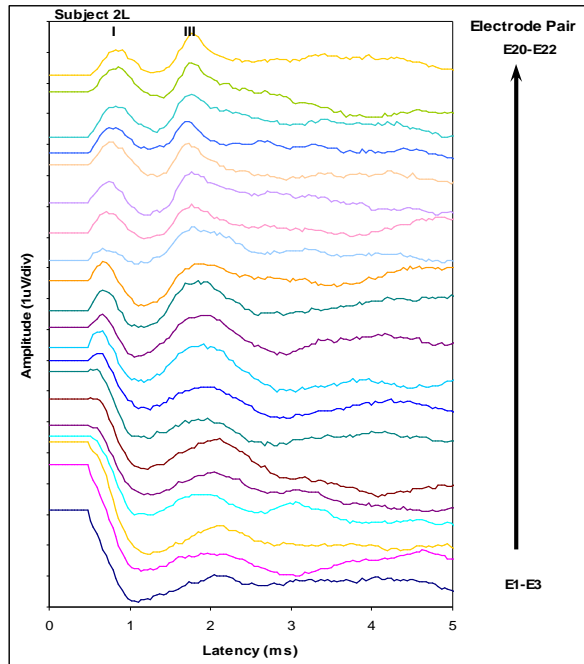

Figure 19. Narrow bipolar stimulation EABRs from Subject 2, left ear (upper panel), and Subject 3 (lower panel), showing data across the electrode pairings for stimulation at either maximum output or “loud comfort” level.

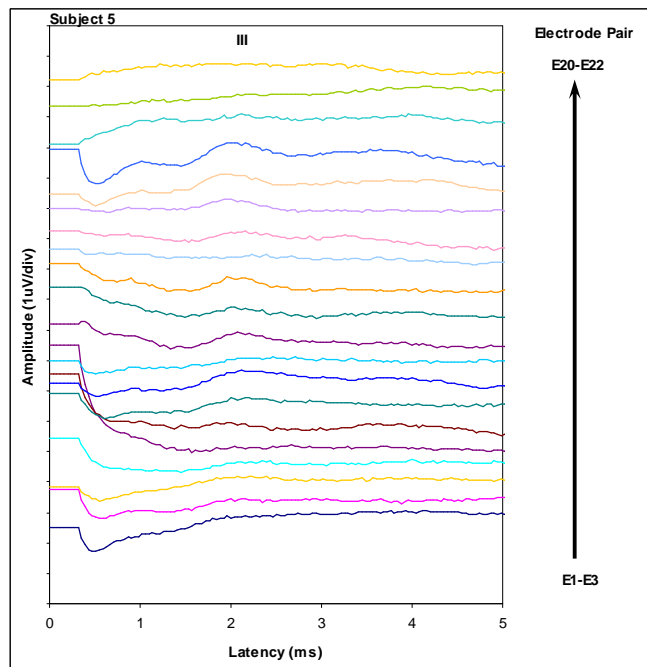
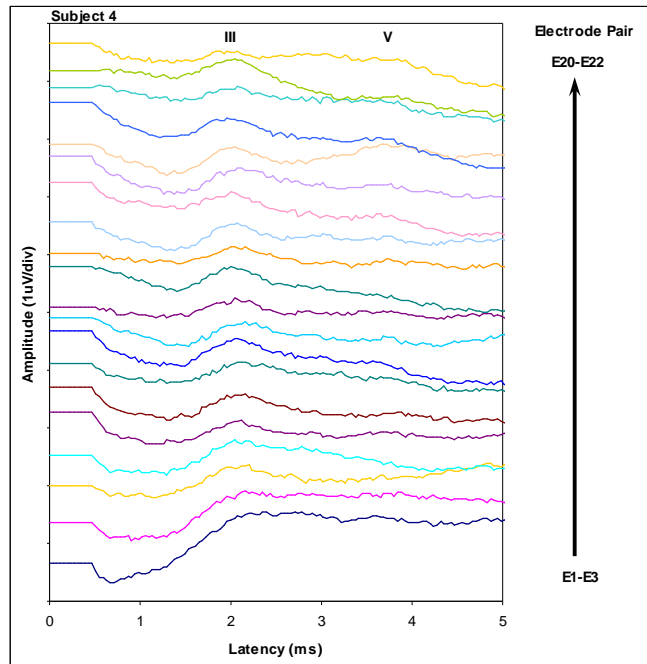

Figure 20. Narrow bipolar stimulation EABRs from Subject 4 (upper panel), and Subject 5, right ear (lower panel), showing data across the electrode pairings for stimulation at either maximum output or “loud comfort” level.

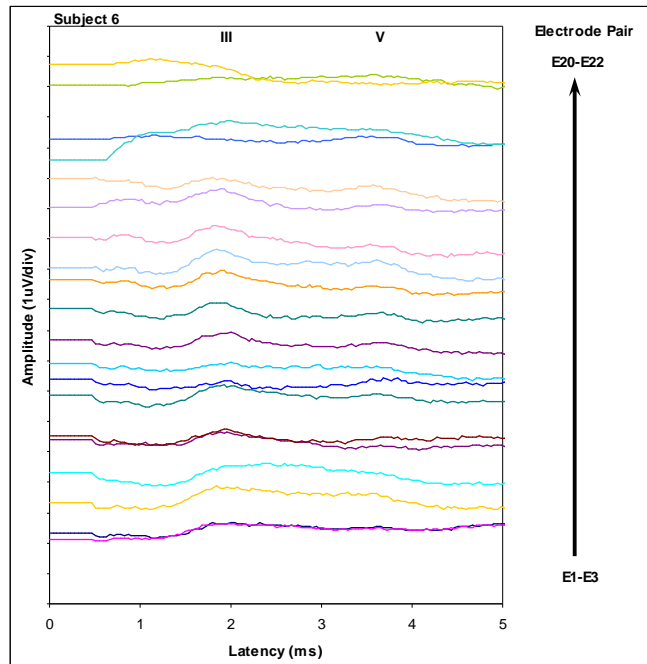

Figure 21. Narrow bipolar stimulation EABRs from Subject 6, showing data across the electrode pairings for stimulation at either maximum output or “loud comfort” level.

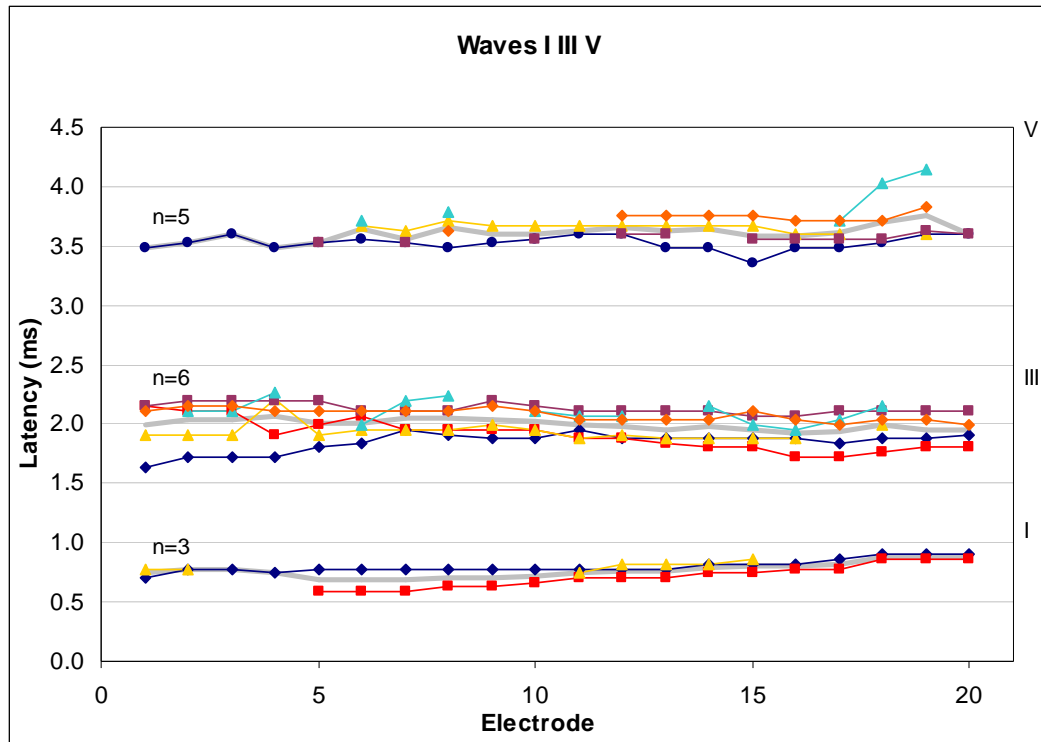

Figure 22. Measured latencies across all ears with identifiable Waves I, III, and V, for each of the narrow bipolar electrode pairings.

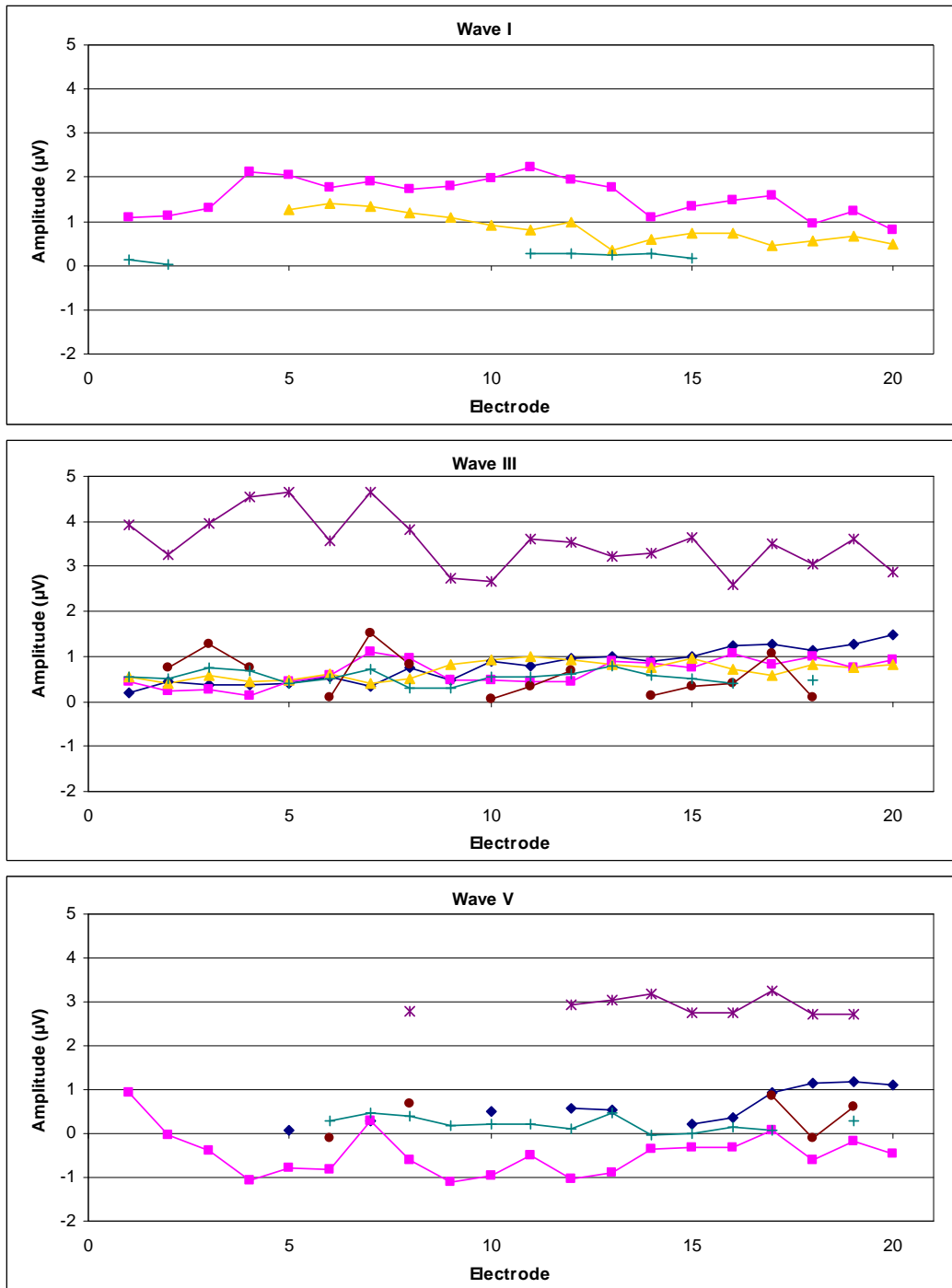

Figure 23. Measured amplitudes across all ears with identifiable Waves I, III, and V, for each of the narrow bipolar electrode pairings.

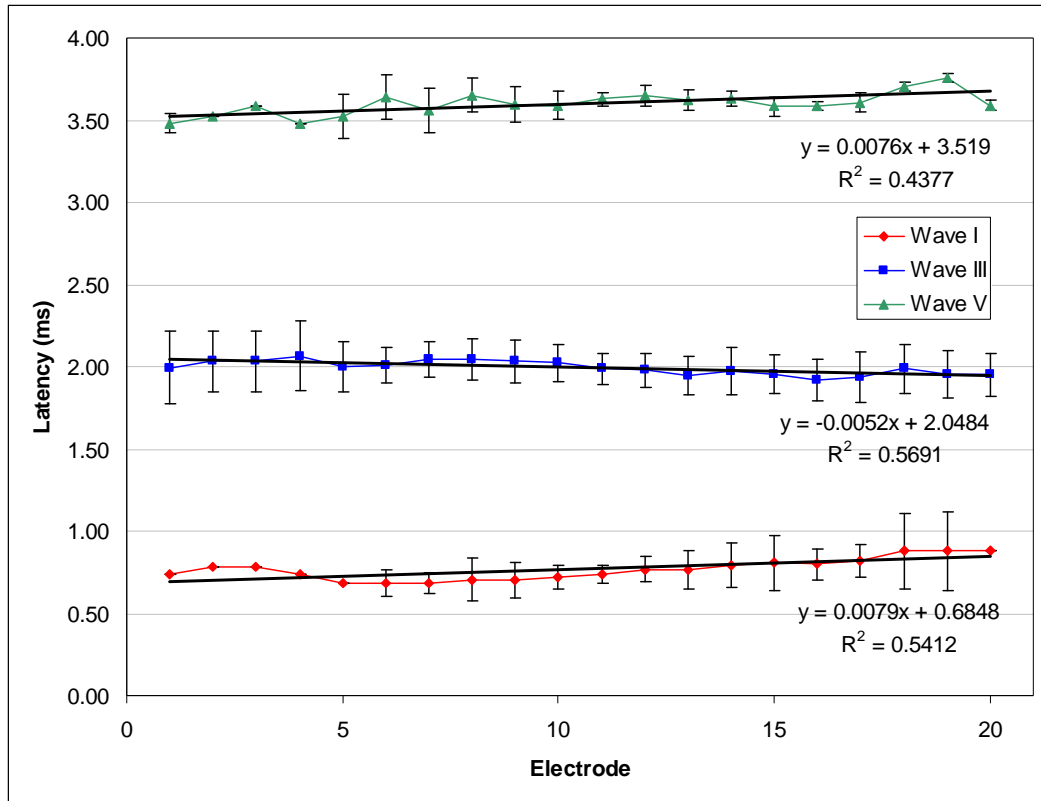

Figure 24. Means and standard deviations of latencies for identifiable Waves I, III, and V for each of the narrow bipolar electrode pairings. Also shown are best-fit linear regression lines.

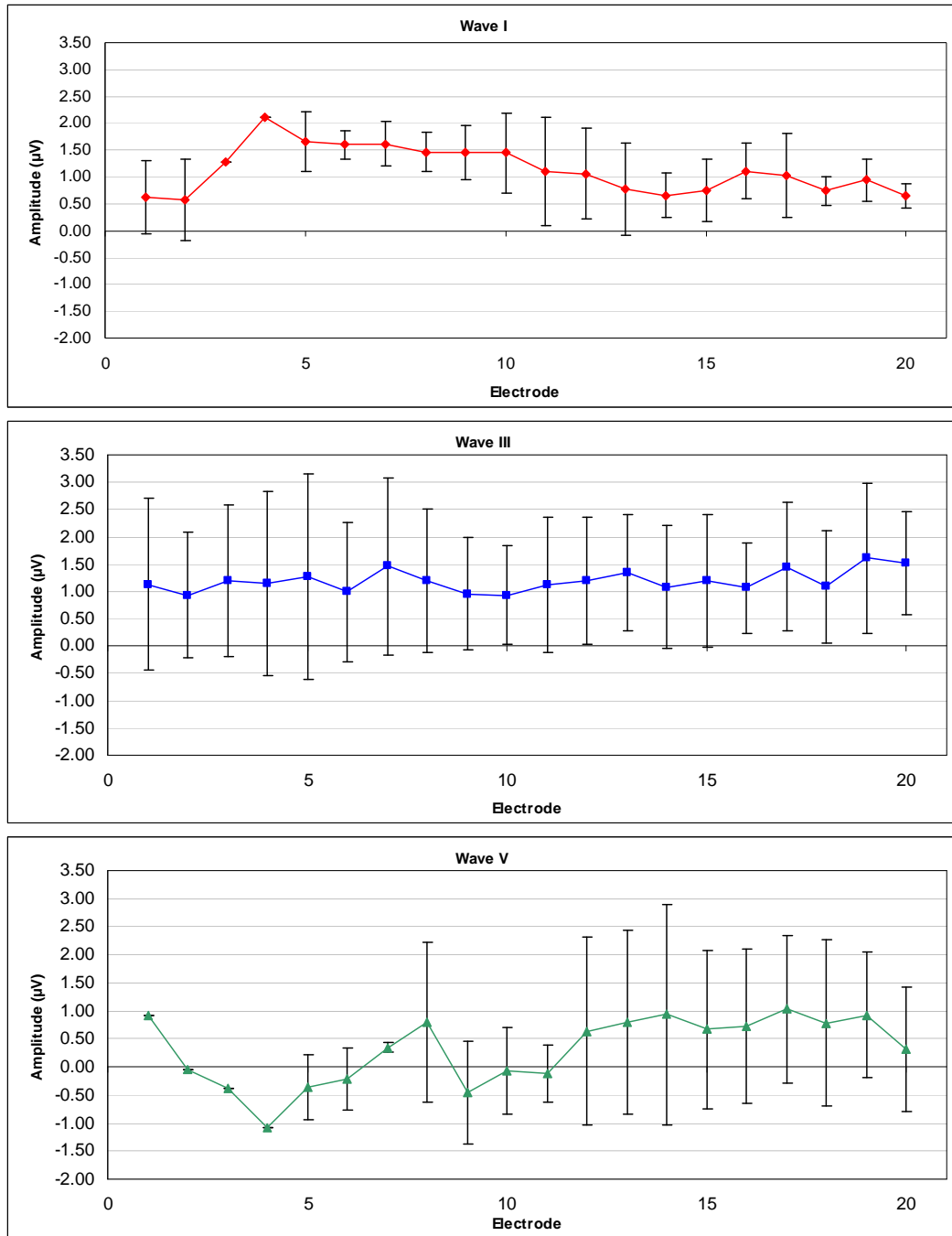

Figure 25. Means and standard deviations of amplitudes for identifiable Waves I, III, and V for each of the narrow bipolar electrode pairings.



## **EABR Model**

The output of the MatLab simulation and a set of typical electrically evoked ABR waveforms that were published in the literature (Hay-McCutcheon, 2002) are shown in Figure 26 in the left panel. Displayed are a series of MatLab-simulated EABR waveforms measured over a range of stimulus levels as indicated numerically on the right side of the plot. The stimulus levels in the simulation range from just at a typical threshold of hearing (140) up to a level that would likely be near the upper comfortable limit (200) for most cochlear implant users.

The right panel in Figure 26 displays the published series of EABR results that were obtained from the subject with stimulation of electrode E5 on their implanted array. The range of stimulus levels used for measurements on this patient extended from their threshold of hearing up to a medium comfortable loudness level. In general, the amplitude growth and latency shifts for the EABRs across stimulation levels compare reasonably well between the simulated and the measured electrically evoked ABR results. The general wave shape (morphology and ability to identify peaks) is slightly better, however, for the simulated series than for the published data.

Both the simulation and the measured electrical ABR results in Figure 26 show three well-defined wave peaks, representing Waves I, III, and V. This is typical of the pattern of results (missing Waves II and IV, which are smaller and

less robust peaks) seen with hearing impairment with acoustical stimulation. As would be expected in a typical ABR, the simulation results demonstrate increased amplitude, shortened peak latency, and a more well-defined waveform morphology as stimulus intensity is increased. The published series of waves shows the same result.

One difference in the traces in Figure 26 is that in the measured data from this particular patient there appears to be an ABR response threshold at about 167-170, while in the simulation ABRs the threshold is reached at approximately 140 - i.e. at a lower (more favorable threshold) stimulus level. A range of ABR threshold values can be found across cochlear implant patients so this does not invalidate the legitimacy of the simulation for the purposes for which it was intended. While not done in the current MatLab simulation, it would be possible to modify the algorithm to include definition of patient threshold.

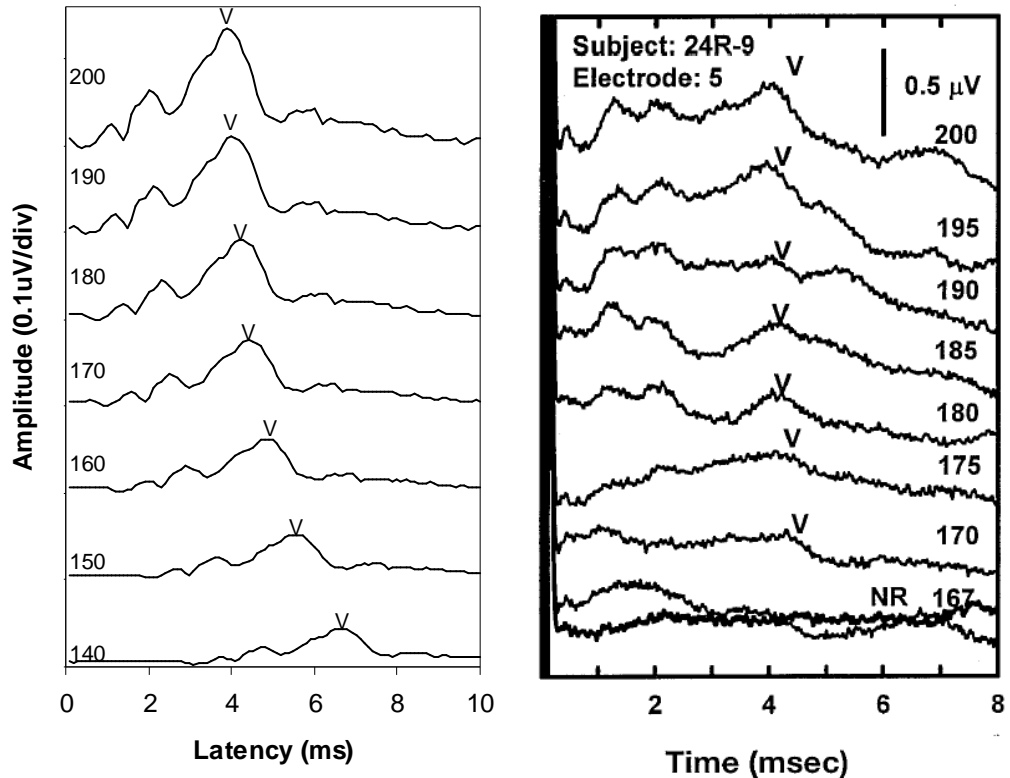

Figure 26. The amplitude and latency patterns for a series of EABRs with increasing stimulus intensities. The numbers attached to the curves are the Current Level of the stimuli. On the left are results from the simulation, and on the right are the results measured on a cochlear implant patient. (Measured EABR results from Hay-McCutcheon *et al.*, 2002)

### Measured EABRs versus Predicted EABRs

Because they provided the best morphology results and the most identifiable peaks, the data from the EABRs from Subjects 1 and 2 were used as the basis to evaluate the computer simulation model that was developed for purposes of this study. For these subjects, because the amplitude of the peaks was higher at maximum stimulation or “loud comfort” level, it was also possible to

collect waveforms for decreasing stimulus intensity. The EABR data collected across stimulus level for a basal and an apical electrode pairing from these subjects are compared to the MatLab model waveforms in Figures 27 and 28. Only the right ear of Subject 2 is shown, but the left ear of this bilaterally implanted subject showed similar results. Identifiable Wave V peaks are marked on the experimental data sets.

The empirical data collected from these two subjects are at least as good in terms of morphology as the published data shown in Figure 29, and actually are somewhat better for Subject 2, although they are again slightly less defined than the MatLab model predictions. Subject 2 produced better morphology waves overall, with amplitude patterns more in sync with those expected for normal acoustic ABRs and those predicted by the MatLab model. In contrast, Subject 1 showed larger Wave III amplitudes than Wave V, a pattern that is occasionally seen, but which is not as common in acoustically elicited responses.

Latency information is more often used in diagnostic applications of ABRs because it is more stable across different subjects and conditions than amplitude data. In fact, Wave V, when present, is generally at the predicted latencies for the model. As expected, as the intensity level is reduced, Wave V latency systematically increases for both subjects. Threshold level for both subjects closely matches the simulated threshold.

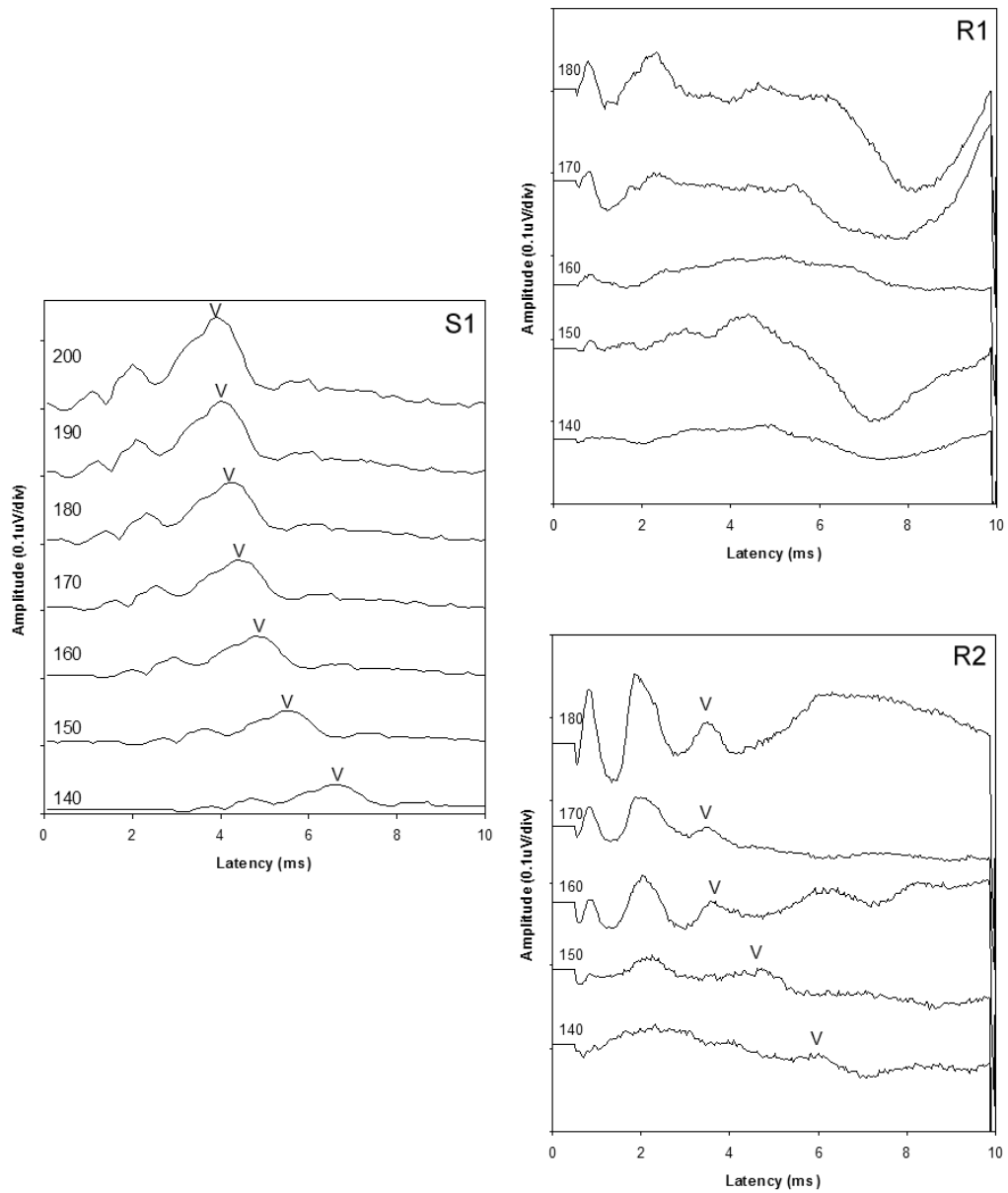

Figure 26. The panel on the left shows modeled EABRs generated by MatLab, while the panels on the right are EABRs recorded from research Subject 1. R1 waveforms were elicited from the basal electrode pair E1 and E11, and R2 waveforms were elicited from the apical electrode pair E11 and E22, across a range of stimulation intensities.

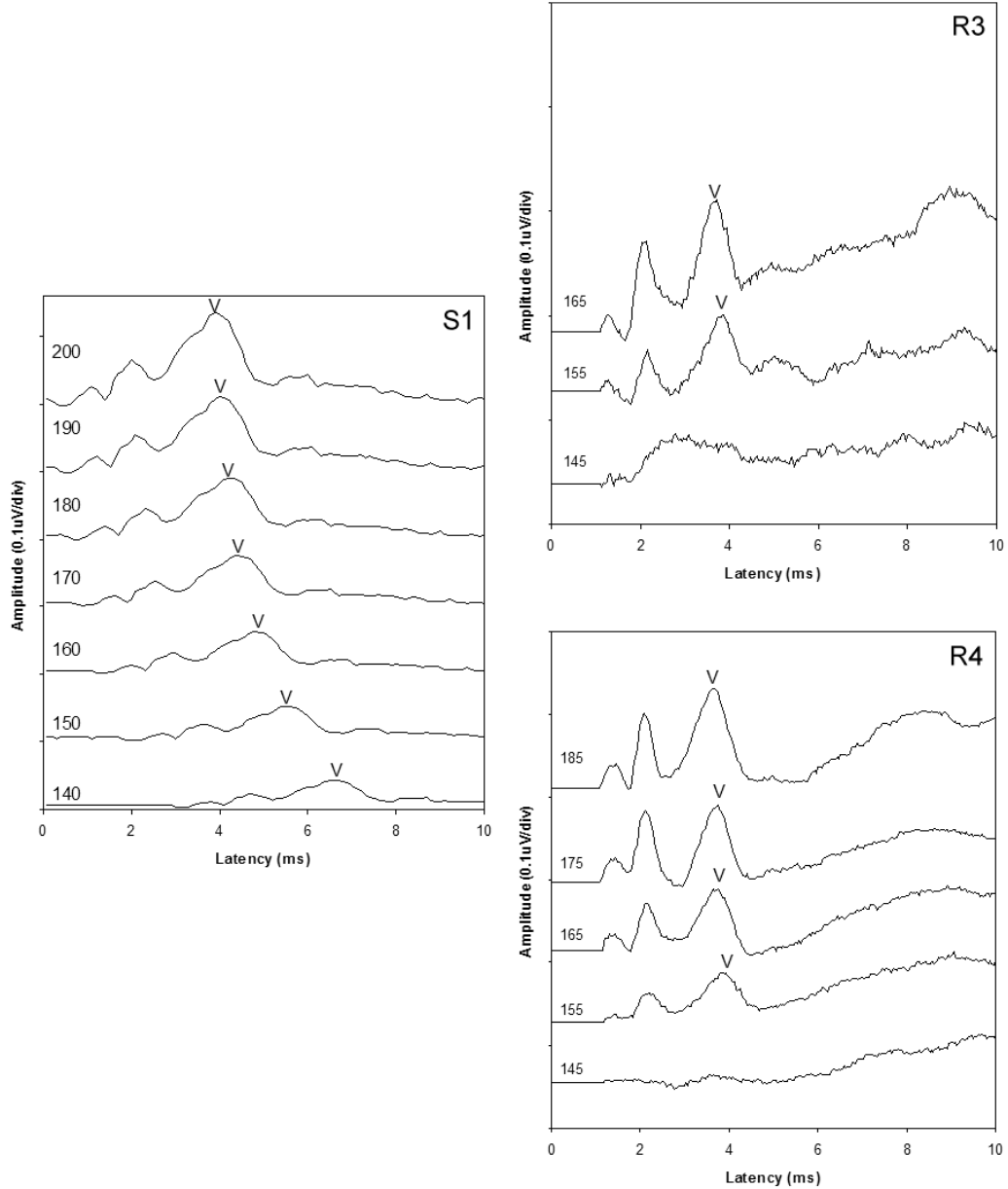

Figure 27. The panel on the left shows modeled EABRs generated by MatLab, while the panels on the right are EABRs recorded from the right ear of research Subject 2. R3 waveforms were elicited from the basal electrode pair E1 and E11, while R4 waveforms were elicited from the apical electrode pair E10 and E21, across a range of stimulation intensities.

It is notable that the EABRs collected from these subjects are not as well defined for the basal electrode pair (electrodes E1 and E11) as they are for the apical electrode pair (electrodes E11 and E22 for Subject 1, and E10 and E21 for Subject 2 due to nonfunctioning of electrode E22 in the latter subject). The difference is greater for Subject 1 than for Subject 2.

## CHAPTER 5

### DISCUSSION

The reasons for a failure to obtain good EABRs in all subjects and ears is not entirely clear. It is important to note, however, that it is not an uncommon finding in the field that some implant recipients give much better evoked responses than do others. This variability in measurable responsivity is also seen clinically with hearing-impaired patients with lesser degrees of loss in measurement of acoustically stimulated ABRs. Even in acoustic ABRs, there are a range of normal ABR morphologies, amplitude and latency values.

It is not known whether or not differences between the subjects in terms of their years of deafness, or years of experience with the implant, or other factors related to the implant or its sound processing might explain the morphology and amplitude differences in the EABRs produced. Examination of the demographic data, hearing loss history, and implant use history for the subjects in this study did not reveal an overall obvious pattern or reason for the failure to obtain EABRs in some subjects and conditions. The two subjects with the clearest responses, Subjects 1 and 2, do however, illustrate some differences that may possibly be factors in the morphology of the obtained responses. Subject 1 was a less experienced implant user than Subject 2; Specifically, Subject 1 had his device



only about 4 years prior to this study and had not previously participated in any cochlear implant research, while Subject 2 had worn her device about 12 years and had been a research subject for more than 5 years in studies done by other researchers (not the author of this study). Subject 1 also had a longer period of auditory deprivation due to more years of profound deafness prior to cochlear implantation. Although obviously a link cannot be established with merely two subjects, these subjects' differences in history of stimulation of the auditory system are intriguing because they suggest that stimulation helps in development of measurable synchrony of neural responses over time.

Despite differences in their history of implant use and in the measured EABRs, however, both subjects were highly satisfied and highly successful cochlear implant users, with outstanding performances on speech recognition with their implants, even without visual lipreading cues. Both subjects could also communicate over the telephone, a task which relies entirely on hearing through their implant since no visual cues are available. This reiterates the known fact that the inability to measure the EABR does not always correspond with the patient's actual performance with the device, although the presence of a good morphology response is more likely to correspond to good performance than the absence of a response will correspond to bad performance.

One topic of interest in this thesis was whether or not the use of the novel technique of measuring with narrow bipolar stimulation rather than the conventional wide bipolar approach would result in some frequency specificity of

the responses. In fact, the slopes of most of the linear-fit trend lines for the mean latency data were minimal, so that there was not an obvious characteristic EABR waveform morphology unique to the neural population excited by each electrode pair along the array. The exception was in the amplitude data, and there did appear to be a trend across the individual data for some subjects to produce slightly higher amplitude and clearer responses for apical rather than basal pairings. Since, as was discussed in the background section, neural tissue is essentially organized from high frequency to low frequency as one moves from the base of the cochlea to the apex, this could possibly indicate that this novel approach to EABR measurement could serve as an objective measure of the spectral target for each electrode if the pattern found can be replicated across a larger number of subjects.

If differences do occur for basal versus apical stimulation, it is likely that it has to do with the need to innervate sufficient numbers of neural populations to elicit strong peaks in the response, and possibly the fact that with acoustic ABRs elicited with a broadband click stimulus, it is well-known that responsivity is primarily from the 2000 to 4000 Hz region. The basal electrode pair tends to elicit a high-frequency broadband hearing perception at frequencies above about 4000 Hz, while the apical electrode pair tends to elicit a lower-frequency broadband hearing perception that better encompasses the most important frequency region for brainstem responses. As shown in the Greenwood map

(Greenwood, 1990, see Figure 15), electrodes in the apical portion of the cochlea do stimulate frequencies below about 4000 Hz.

A limitation of the use of narrow bipolar stimulation mode, however, was that fact that relatively few of the subjects demonstrated good responses using this technique, as opposed to the standard wide bipolar stimulation technique. Just like with the traditional wide bipolar stimulation mode, the precise reasons for the inter-subject variability are not completely known. One obvious complicating factor is that, when using narrow bipolar stimulation it takes a higher electrical stimulus intensity level to reach an individual patient's judgment of "loud comfortable" than it does when using wide bipolar stimulation. Given the output limits of the measurement system, there were a number of cases where the maximum output of the stimulus generator still was not high enough for the patient to call it "loud comfortable". Thus, stimulation was less than that needed for an optimal EABR recording. This occurred with most of the subjects for at least some electrode pairings, but appeared to be more prevalent in those cases where no response or a poor morphology response was obtained. That said, this factor cannot explain all of the variability because Subject 2, who produced the best responses, also reported that the maximum stimulation level was below her judgment of "loud comfortable". It is notable, however, that loudness judgments can be unreliable and dependent upon the individual's personality and experience.

Another interesting finding with narrow bipolar stimulation is that more patients produced an identifiable Wave III than V, and Wave III was often of

higher amplitude than Wave V. This finding is not consistent with the acoustic ABR literature or the wide bipolar stimulation literature, where Wave V is typically the most prominent peak. More research on a larger group of subjects will need to be done to explain this discrepancy and to further delineate what is being measured when a narrow bipolar stimulation mode is used for EABRs in cochlear implant recipients.

In any case, the fact that not all subjects produce EABRs, or good morphology and high enough amplitude responses to provide confidence in measurements, is one argument for why modeling may be very useful. An absence of EABRs in some implant recipients using standard clinical measurement practices impacts the ability to use EABRs to evaluate the effects of signal processing algorithms. Thus, modeling based on good morphology waveforms obtained from those subjects with measurably good EABRs may assist in developments that will benefit other patients in whom good EABRs cannot be measured.

In this study, the simulated (predicted) waveforms were often of better morphology and clarity than the actual measured waveforms, but they still tended to have similar amplitudes and intensities compared with both the published data and those empirically collected in this study on the two subjects who produced the best EABRs. Further, estimated threshold of response on the intensity functions was a reasonably good match to the measured data.

There are some aspects of the auditory system that were not included in the MatLab model, including normal nonlinearities inherent in the human auditory system, and the use of post-collection filtering of the responses in addition to signal averaging, and the model might be improved with further work. Nevertheless, the simulation results appear to be valid in comparison to the actual waveforms, in that they are producing the expected patterns. The use of this MatLab model, or an extension of it thus appears to be a potentially useful tool for future research in the area of cochlear implants.

## CHAPTER 6

### CONCLUSIONS

In conclusion, the work presented herein provides a computer model that is a good first approximation, and that performs reasonably well to predict electrically evoked auditory brainstem responses (EABRs) in patients using cochlear implants. One strong rationale for the use of modeling is provided by the fact that a number of subjects in the study did not produce measurable EABRs despite being high performers with their implants.

In addition, the use of a novel approach to measurement via narrow bipolar electrode pairings appears promising in terms of obtaining the possibility of more site-specific, frequency-selective EABRs. Such an approach might prove useful in development of better signal processing algorithms for cochlear implant sound processors, and in understanding why some patients perform better with their implant than do others.

Much more work needs to be done, however, in terms of understanding electrically evoked potentials in cochlear implant recipients because even those subjects with the same level of speech recognition and daily performance with their cochlear implants produced quite different EABR morphologies. More study may help elucidate factors that contribute to the ability to measure

responses, such as the duration of deafness or implant use, or the signal processing or other implant factor such as number of active electrodes.

It would be good to extend this type of modeling approach to other EAPs in the evoked and endogenous potential family as well, as these may help more in characterizing the speech performance of patients. As CI technology and signal processing continue to improve and more deaf patients receive unilateral, and more recently, bilateral implants, there will be a greater need for better measurements techniques. This thesis work is a first step in that direction.

## BIBLIOGRAPHY

- Beynon AJ, Snik AF, van den Broek P. Evaluation of cochlear implant benefit with auditory cortical evoked potentials. *Int J Audiol.* 2002 Oct; 41(7):429-35.
- Blackwood, DH, St Clair, DM, Blackburn, IM, Tyrer, GM. Cognitive brain potentials and psychological deficits in Alzheimer's dementia and Korsakoff's amnesic syndrome. *Psychol Med.* 1987 17:349-358.
- Firszt JB, Chambers RD, Kraus N, Reeder RM. Neurophysiology of cochlear implant users I: effects of stimulus current level and electrode site on the electrical ABR, MLR, and N1-P2 response. *Ear Hear.* 2002 Dec; 23(6):502-515.
- Firszt JB, Rotz LA, Chambers RD, Novak MA. Electrically evoked potentials recorded in adult and pediatric CLARION implant users. *Ann Otol Rhinol Laryngol Suppl.* 1999 Apr; 177:58-63.
- Fjell AM, Walhovd KB. Effects of auditory stimulus intensity and hearing threshold on the relationship among P300, age, and cognitive function. *Clin Neurophysiol.* 2003 May; 114(5):799-807.
- Goodin DS, Squires KC, Starr A. Long latency event-related components of the auditory evoked potential in dementia. *Brain.* 1978; 101:635-648.
- Gordon KA, Papsin BC, Harrison RV. Activity-dependent developmental plasticity of the auditory brain stem in children who use cochlear implants. *Ear Hear.* 2003 Dec; 24(6):485-500.
- Groenen, PA, Beynon, AJ, Snik, AF, van den Broek, P. Speech-evoked cortical potentials and speech recognition in cochlear implant users. *Scand Audiol.* 2001, 30: 31-40.
- Hay-McCutcheon MJ, Brown CJ, Clay KS, Seyle K. Comparison of electrically evoked whole-nerve action potential and electrically evoked auditory brainstem response thresholds in nucleus CI24R cochlear implant recipients. *J Am Acad Audiol.* 2002 Sep;13(8):416-427.
- Kaga, K, Kodera, K. P300 response to tones and speech sounds after a cochlear implant: A case report. *Laryngoscope.* 1999, 101: 905-907.



Kraus, N, Micco, AG, Koch, DB, et al. The mismatched negativity cortical evoked potential elicited by speech in cochlear implant users. *Hear Res.* 1993, 65: 118-124.

Katz J, ed. *Handbook of Clinical Audiology, Fourth Edition.* Williams and Wilkins, Baltimore; 1994.

Kileny PR. Use of electrophysiologic measures in the management of children with cochlear implants: brainstem, middle latency, and cognitive (P300) responses. *Am J Otol.* 1991;12(Suppl): 37-42.

Kubo T, Yamamoto K, Iwaki T, Matsukawa M, Doi K, Tamura M. Significance of auditory evoked responses (EABR and P300) in cochlear implant subjects. *Acta Otolaryngol.* 2001 Jan; 121(2):257-61.

Krueger B, Joseph G, Rost U, Strauss-Schier A, Lenarz T, Buechner A. Performance groups in adult cochlear implant users: speech perception results from 1984 until today. *Otol Neurotol.* 2008 Jun; 29(4):509-12.

Micco AG, Kraus N, Koch DB, McGee TJ, Carrell TD, Sharma A, Nicol T, Wiet RJ. Speech-evoked cognitive P300 potentials in cochlear implant recipients. *Am J Otol.* 1995 Jul; 16(4):514-20.

Muhler R, Ziese M, Kevanishvili Z, Schmidt M, von Specht H. Visualization of stimulation patterns in cochlear implants: application to event-related potentials (P300) in cochlear implant users. *Ear Hear.* 2004 Apr; 25(2):186-190.

Näätänen R. the role of attention in auditory information processing as revealed by event-related brain potentials and other brain measures of cognitive function. *Behav Brain Res.* 1990; 13:201-233.

Okusa M, Shiraishi T, Kubo T, Nageishi Y. Effects of discrimination difficulty on cognitive event-related brain potentials in patients with cochlear implants. *Otolaryngol Head Neck Surg.* 1999 Nov;121(5):610-615.

Oviatt, DI, Kileny, Pr. Auditory event-related potentials elicited from cochlear implant recipients and hearing subjects. *Am J Audiol.* 1991; Nov. 48-55.

Parkinson, AJ, Arcaroli, J, Staller, SJ, Arndt, PL, Cosgriff, A, Ebinger, K. The Nucleus® 24 Contour™ cochlear implant system: Adult clinical trial results. *Ear and Hearing,* 2002; 23 (Suppl), 41-48.

- Picton TW. The P300 wave of the human event-related potential. *J Clin Neurophysiol.* 1992; 9:456-479.
- Sharma A, Dorman MF, Spahr AJ. A sensitive period for the development of the central auditory system in children with cochlear implants: implications for age of implantation. *Ear Hear.* 2002 Dec;23(6):532-539.
- Sharma A, Dorman MF, Spahr AJ. Rapid development of cortical auditory evoked potentials after early cochlear implantation. *Neuroreport.* 2002 Jul 19;13(10):1365-1368.
- Sharma A, Tobey E, Dorman M, Bharadwaj S, Martin K, Gilley P, Kunkel F. Central auditory maturation and babbling development in infants with cochlear implants. *Arch Otolaryngol Head Neck Surg.* 2004 May;130(5):511-516.
- Singh S, Liasis A, Rajput K, Towell A, Luxon L. Event-related potentials in pediatric cochlear implant patients. *Ear Hear.* 2004 Dec;25(6):598-610.
- Squires KC, Hecox KE. Electrophysiological evaluation of higher level auditory processing. *Semin Hear.* 1983; 4:415-433.
- Thai-Van H, Gallego S, Truy E, Veuillet E, Collet L. Electrophysiological findings in two bilateral cochlear implant cases: does the duration of deafness affect electrically evoked auditory brain stem responses. *Ann Otol Rhinol Laryngol.* 2002 Nov; 111(11):1008-1014.
- Turner, C, Gantz, BJ, Reiss, L. Integration of acoustical and electrical hearing. *J Rehab Res Dev* 2008; 45(5): 769-778.
- Vannier E, Adam O, Motsch JF. Objective detection of brainstem auditory evoked potentials with a priori information from higher presentation levels. *Artificial Intelligence in Medicine* 25 (2002) 283–301.
- Beynon AJ, Snik AF, van den Broek P. Evaluation of cochlear implant benefit with auditory cortical evoked potentials. *Int J Audiol.* 2002 Oct; 41(7):429-35.
- Blackwood, DH, St Clair, DM, Blackburn, IM, Tyrer, GM. Cognitive brain potentials and psychological deficits in Alzheimer's dementia and Korsakoff's amnesic syndrome. *Psychol Med.* 1987 17:349-358.
- Firszt JB, Chambers RD, Kraus And N, Reeder RM. Neurophysiology of cochlear implant users I: effects of stimulus current level and electrode site on the electrical ABR, MLR, and N1-P2 response. *Ear Hear.* 2002 Dec; 23(6):502-515.

Firszt JB, Rotz LA, Chambers RD, Novak MA. Electrically evoked potentials recorded in adult and pediatric CLARION implant users. *Ann Otol Rhinol Laryngol Suppl.* 1999 Apr; 177:58-63.

Fjell AM, Walhovd KB. Effects of auditory stimulus intensity and hearing threshold on the relationship among P300, age, and cognitive function. *Clin Neurophysiol.* 2003 May; 114(5):799-807.

Gibson WP, Sanli H, Psarros C. The use of intra-operative electrical auditory brainstem responses to predict the speech perception outcome after cochlear implantation. *Cochleara Implants Int.* 2009; 1:53-57.

Goodin DS, Squires KC, Starr A. Long latency event-related components of the auditory evoked potential in dementia. *Brain.* 1978; 101:635-648.

Gordon KA, Papsin BC, Harrison RV. Activity-dependent developmental plasticity of the auditory brain stem in children who use cochlear implants. *Ear Hear.* 2003 Dec; 24(6):485-500.

Gordon KA, Valero J, van Hoesel R, Papsin BC. Abnormal timing delays in auditory brainstem responses evoked by bilateral cochlear implant use in children. 2008 Feb; 29(2): 193-198.

Groenen, PA, Beynon, AJ, Snik, AF, van den Broek, P. Speech-evoked cortical potentials and speech recognition in cochlear implant users. *Scand Audiol.* 2001, 30: 31-40.

Hay-McCutcheon MJ, Brown CJ, Clay KS, Seyle K. Comparison of electrically evoked whole-nerve action potential and electrically evoked auditory brainstem response thresholds in nucleus CI24R cochlear implant recipients. *J Am Acad Audiol.* 2002 Sep;13(8):416-427.

Kaga, K, Kodera, K. P300 response to tones and speech sounds after a cochlear implant: A case report. *Laryngoscope.* 1999, 101: 905-907.

Kraus, N, Micco, AG, Koch, DB, et al. The mismatched negativity cortical evoked potential elicited by speech in cochlear implant users. *Hear Res.* 1993, 65: 118-124.

Katz J, ed. *Handbook of Clinical Audiology, Fourth Edition.* Williams and Wilkins, Baltimore; 1994.

- Kileny PR. Use of electrophysiologic measures in the management of children with cochlear implants: brainstem, middle latency, and cognitive (P300) responses. *Am J Otol.* 1991;12(Suppl): 37-42.
- Kubo T, Yamamoto K, Iwaki T, Matsukawa M, Doi K, Tamura M. Significance of auditory evoked responses (EABR and P300) in cochlear implant subjects. *Acta Otolaryngol.* 2001 Jan; 121(2):257-61.
- Micco AG, Kraus N, Koch DB, McGee TJ, Carrell TD, Sharma A, Nicol T, Wiet RJ. Speech-evoked cognitive P300 potentials in cochlear implant recipients. *Am J Otol.* 1995 Jul; 16(4):514-20.
- Muhler R, Ziese M, Kevanishvili Z, Schmidt M, von Specht H. Visualization of stimulation patterns in cochlear implants: application to event-related potentials (P300) in cochlear implant users. *Ear Hear.* 2004 Apr; 25(2):186-190.
- Näätänen R. the role of attention in auditory information processing as revealed by event-related brain potentials and other brain measures of cognitive function. *Behav Brain Res.* 1990; 13:201-233.
- Okusa M, Shiraishi T, Kubo T, Nageishi Y. Effects of discrimination difficulty on cognitive event-related brain potentials in patients with cochlear implants. *Otolaryngol Head Neck Surg.* 1999 Nov;121(5):610-615.
- Oviatt, DI, Kileny, Pr. Auditory event-related potentials elicited from cochlear implant recipients and hearing subjects. *Am J Audiol.* 1991; Nov. 48-55.
- Picton TW. The P300 wave of the human event-related potential. *J Clin Neurophysiol.* 1992; 9:456-479.
- Sharma A, Dorman MF, Spahr AJ. A sensitive period for the development of the central auditory system in children with cochlear implants: implications for age of implantation. *Ear Hear.* 2002 Dec;23(6):532-539.
- Sharma A, Dorman MF, Spahr AJ. Rapid development of cortical auditory evoked potentials after early cochlear implantation. *Neuroreport.* 2002 Jul 19;13(10):1365-1368.
- Sharma A, Tobey E, Dorman M, Bharadwaj S, Martin K, Gilley P, Kunkel F. Central auditory maturation and babbling development in infants with cochlear implants. *Arch Otolaryngol Head Neck Surg.* 2004 May;130(5):511-516.

Singh S, Liasis A, Rajput K, Towell A, Luxon L. Event-related potentials in pediatric cochlear implant patients. *Ear Hear.* 2004 Dec;25(6):598-610.

Squires KC, Hecox KE. Electrophysiological evaluation of higher level auditory processing. *Semin Hear.* 1983; 4:415-433.

Thai-Van H, Gallego S, Truy E, Veillet E, Collet L. Electrophysiological findings in two bilateral cochlear implant cases: does the duration of deafness affect electrically evoked auditory brain stem responses. *Ann Otol Rhinol Laryngol.* 2002 Nov; 111(11):1008-1014.

Vannier E, Adam O, Motsch JF. Objective detection of brainstem auditory evoked potentials with a priori information from higher presentation levels. *Artificial Intelligence in Medicine* 25 (2002) 283–301.

## APPENDIX A

### MATLAB Code

```
% ABR Simulation Module

% unit - Unitary Neural Response: the action potential of a single neuron
% firing
% CL - Current Level: clinical unit of stimulus current
% I - Stimulus current measured in uA
% EP - Evoked Potential: electrical potential elicited by a stimulus
% Ls - Latency of the evoked response
% ABR - Auditory Brainstem Response

clc
clear

load unit.txt; % load unitary neural response
load time.txt; % load time scale
CL = input('Enter CL[1-255]: '); % set stimulus level
N = 1000; % number of responses averaged
k = 1E-3; % unitary response scaling constant

I = 10*(175^(CL/255)); % stimulus current in uA
stim = ones(1,1); % initialize electrode array
stim = I * stim * k; % load stimulus level into array
EP = conv(unit, stim); % calculate evoked potential
Ls = round(4000 * exp(-0.006*(CL^1.36))); % calculate latency shift
[m,n] = size(EP); % get length of EP vector
for i = 1:n
    Decay(i) = 8 * exp(-i/20); % calculate propagation decay
end
for i = 1:n
    EP(i) = EP(i) * Decay(i); % introduce propagation decay
end
ABR = zeros(1,n); % initialize EP response
% accumulator
for i = 1:N
    EPS = zeros(1,n); % repeat EP generation N times
    EPS(Ls+1:n) = EP(1:n-Ls); % create vector for total potential
    RNA = 2 * (0.5 - rand(1,n)); % shift response
    EPS = EPS + RNA; % introduce ambient neural activity
    ABR = ABR + EPS; % summate total potential
end
ABR = ABR/N; % accumulate EP responses
% average the EP response

figure; % plot ABR
plot(time,ABR)
axis([0 12.0 -1 1])
title('MLR');
xlabel('Time (ms)');
ylabel('Evoked Potential (uV)');
```

```

% ABR Data Extraction Module

clc
clear

Filename = input('Enter EP filename: ', 's'); % select file
Record = 1; % initialize record counter
FileStats = dir(Filename); % get file size
NRecords = int16(FileStats.bytes/2560) % compute number of records in
% file

while Record
    Record = input('Enter Record Number: '); % select record number
    if Record
        if Record <= NRecords
            Filepointer = Record * 2560; % get requested record
            FID = fopen(Filename);
            fseek(FID, Filepointer, -1);
            DATA = fread(FID, 256, 'int16'); % load data array from file
            fclose (FID);
            DATA = -DATA; % invert data values
            plot(DATA) % plot data for verification
        else
            'Invalid Record'
        end
    end
end
close;

```

## APPENDIX B

### LIST OF PUBLICATIONS

Simulation of Electrically-Evoked Auditory Brainstem Response. Miller, DA. University of Denver Graduate Research Day, March 2005

Computer Modeling of the Cochlear Implant EABR. Miller, DA. University of Denver Graduate Research Day, May 2006

Sequential Electrode EABRs in Cochlear Implant Subjects. Miller, DA, Matin, MA. American Academy of Audiology, April 2007

A Model for Simulation of Electrically-Evoked Neural Responses. Miller, DA, Matin, MA. SPIE, August 2009 [accepted]