

University of Denver

Digital Commons @ DU

---

Electronic Theses and Dissertations

Graduate Studies

---

8-1-2013

## eStudy of BER Performance in Passive Optical Networks with Different Modulation Techniques

Ayoob Alateeq  
University of Denver

Follow this and additional works at: <https://digitalcommons.du.edu/etd>



Part of the [Electrical and Computer Engineering Commons](#)

---

### Recommended Citation

Alateeq, Ayoob, "eStudy of BER Performance in Passive Optical Networks with Different Modulation Techniques" (2013). *Electronic Theses and Dissertations*. 12.  
<https://digitalcommons.du.edu/etd/12>

This Thesis is brought to you for free and open access by the Graduate Studies at Digital Commons @ DU. It has been accepted for inclusion in Electronic Theses and Dissertations by an authorized administrator of Digital Commons @ DU. For more information, please contact [jennifer.cox@du.edu](mailto:jennifer.cox@du.edu), [dig-commons@du.edu](mailto:dig-commons@du.edu).

eStudy of BER Performance in Passive Optical Networks with Different Modulation  
Techniques

---

A Thesis

Presented to

the Faculty of the Daniel Felix Ritchie School of Engineering and Computer Science  
University of Denver

---

In Partial Fulfillment  
of Requirements for the Degree  
Master of Science

---

by

Ayoob Alateeq

August 2013

Advisor: Mohammad A. Matin

©Copyright by Ayoob Alateeq 2013

All Rights Reserved

Author: Ayoob Alateeq  
Title: Study of BER Performance in Passive Optical Networks with Different Modulation Techniques  
Advisor: Mohammad A. Matin  
Degree Date: August 2013

### **Abstract**

The amazing growth in the usage of the broadband services has motivated a number of the services' providers to find drastic solutions. The percentage of broadband subscribers has increased from 5.3% of the world population in 2007 to 8.5% of the population in 2011. The increase in the number of subcarriers and a high bandwidth requirement are two motivations to demonstrate the broadband service provision. As a promised demonstration of the broadband provision, professionals use optical fiber to account for the present and the future broadband demand.

Power consumption and bandwidth capacity, which the optical fiber has offered, are two main requirements for success of any communication system. In this thesis several implementations have been added to such Passive Optical Network (PON) systems in order to meet the future broadband demand by maintaining the Bit Error Rate (BER). The interaction between Radio Frequency (RF) and optical fiber can support both wired and wireless communication systems. The modulation of RF signals has been tried by using different types in order to study the BER performance when PON is used. Three different optical millimeter signals were analyzed, which are Single Side-Band (SSB), Double Side-Band (DSB), and Optical Carrier Suppression (OCS) and applied to Wavelength Division Multiplexing- Passive Optical Network (WDM-PON) systems. The Orthogonal Frequency Division Multiplexing (OFDM) multi-carrier has been realized as

an advanced modulation format of RF. Two different modulations methods of OFDM were used and compared at different levels.

## **Acknowledgements**

This work would not have been accomplished without my advisor's support and motivation. Dr. Mohammad A. Matin encouraged and supported me during the period of my masters' program from my first day at the University of Denver until the last word I wrote in this thesis report. I would like also thank Dr. Vijya Nnarapreddy and Dr. George Edwards for their help and sincere interest in my research. I also would like to appreciate my colleagues Khaled Alatawi and Fahad Almasoudi for their cooperation in our first paper under the title "Design of Broadband RoF PON for the Last Mile".

Special acknowledgments go to my father, my brothers, and my sisters who supported and motivated me in my studies.

## Table of Contents

Chapter 1.....	1
Introduction.....	<b>Error! Bookmark not defined.</b>
1.1 Background of modern telecommunications .....	2
1.2 Broadband wired access network.....	3
1.2.1 Copper-based access network .....	3
1.2.2 Optical fiber access network .....	4
1.3 Problem Statement .....	6
1.4 Scope of research work .....	6
1.5 Methodology.....	7
1.6 Thesis Organization.....	8
 Chapter 2.....	 9
Passive Optical Network (PON) .....	9
2.1 Description of operation of passive optical network.....	9
2.1.1 Downstream link.....	10
2.1.2 Upstream link .....	10
2.2 History of WDM .....	11
2.3 Overview of WDM.....	12
2.4 WDM standard.....	12
2.5 Overview of WDM-PON.....	13
2.6 TDM-PON vs WDM-PON .....	15
 Chapter 3.....	 16
Different Modulation Methods of RoF in PON .....	16
3.1 RoF Overview .....	16
3.2 Generation methods of millimeter-wave signals over optical links.....	17
3.2.1 RF signal generation by intensity modulated and direct detection (IM-DD) .....	18
3.2.2 External intensity modulation.....	19
3.3 RoF-PON system configuration.....	22
3.4. OFDM Background.....	23
3.5 OFDM overview .....	24
3.6 OFDM modulation .....	25
3.7 Constellation diagram.....	26
3.8 M-ary PSK and QAM.....	28
3.8.1 PSK modulation and demodulation process.....	28

3.8.2 Quadrature Amplitude Modulation (QAM) ....	<b>Error! Bookmark not defined.</b>
3.9 Trading Power and Bandwidth .....	30
3.10 Bit Error Rate (BER).....	31
3.11 OFDM-PON system configuration .....	31
Chapter 4.....	33
Simulation Results .....	33
4.1 Comparison between two externally modulation methods in RoF-PON .....	34
4.2 Comparison of DSB, SSB and OCS modulation methods in WDM-PON .....	<b>Error! Bookmark not defined.</b>
4.3 Modulated RF signals by using OFDM format .....	46
4.3.1. 20 Gb/s OFDM signals over 40-km SMF by using QAM modulation .....	48
4.3.2. 20 Gb/s OFDM signals over 40-km SMF by using PSK modulation .....	52
4.4 Results Evaluation.....	55
Chapter 5.....	57
Conclusion and Future Work .....	57
5.1 Conclusion .....	57
5.2 Future Work.....	58
References.....	60
List of Publications.....	65
Appendix-A Journal Publications .....	66



## **Abbreviations**

<b>AWG</b>	“Arrayed Waveguide Grating”
<b>BER</b>	“Bit Error Rate”
<b>BPSK</b>	“Binary Phase Shift Keying”
<b>CO</b>	“Central Office”
<b>CW</b>	“Continuous Wave”
<b>dB</b>	“Decibel”
<b>dBm</b>	“The measured power referenced to one milli-watt”
<b>DSB</b>	“Double Sideband”
<b>EDFA</b>	“Erbium-doped fiber amplifier”
<b>FDM</b>	“Frequency Division Multiplexing”
<b>FFT</b>	“Fast Fourier Transform”
<b>FTTH</b>	“Fiber-to-the-home”
<b>Gb/s</b>	“gigabit per second”
<b>GHz</b>	“gigahertz”
<b>ICI</b>	“Inter Carrier Interference”
<b>IFFT</b>	“Inverse Fast Fourier Transform”
<b>IM</b>	“Intensity modulation”
<b>ISI</b>	“Inter Symbol Interference”
<b>LAN</b>	“Local Area Network”
<b>LO</b>	“Local oscillator”

<b>MZM</b>	“Mach-Zehnder modulator”
<b>OCS</b>	“Optical carrier suppression”
<b>OFDM</b>	“Orthogonal Frequency Division Multiplexing”
<b>OLT</b>	“Optical line terminal”
<b>ONU</b>	“Optical network unit”
<b>OSNR</b>	“Optical Signal to Noise Ratio”
<b>PON</b>	“Passive optical network”
<b>PRBS</b>	“Pseudo-random bit sequence”
<b>PSK</b>	“Phase Shift Keying”
<b>QAM</b>	“Quadrature Amplitude Modulation”
<b>RF</b>	“Radio Frequency”
<b>RoF</b>	“Radio-over fiber”
<b>SMF</b>	“single mode fiber”
<b>SNR</b>	“Signal to Noise Ratio”
<b>SSB</b>	“Single sideband”
<b>TDMA</b>	“Time Division Multiplexing Access”
<b>WDM</b>	“Wavelength Division Multiplexing”
<b>WLAN</b>	“Wireless Local Area Network”

## List of Figures

Figure 1.1: Figure 1.1 Architecture of a) TDM-PON b) WDM-PON.....	5
Figure 1.2: Thesis Flow Chart.....	8
Figure 2.1: Scheme of two channels bidirectional WD.....	11
Figure 2.2: Spectral grid of coarse wavelength division multiplexing C.....	13
Figure 2.3: Comparison between WDM and AWG.....	14
Figure 3.1: simple scheme of IM-DD modulation.....	19
Figure 3.2 :Optical up-conversion using DSB.....	20
Figure 3.3 :Optical up-conversion using SSB.....	21
Figure 3.4 :Optical up-conversion using OCS.....	21
Figure 3.5. Architecture of WDM-PON system for production and transmission RF signal.....	23
Figure 3.6: Block diagram of process of OFDM system.....	25
Figure 3.7 : BPSk constellation.....	26
Figure 3.8 : 16-QAM constellation.....	27
Figure 3.9 : 64-QAM constellation.....	27
Figure 3.10: QAM or quadrature multiplexing scheme.....	30
Figure 3.11 Architecture of OFDM-WDM-PON system.....	33
Figure 4.1 BER curves of DSB and SSB.....	35
Figure 4.2. OSNR vs BER of SSB and DSB when 80 km SMF used.....	35
Figure 4.3: Eye diagram of received signal when SSB used at 80 km SMF.....	36

Figure 4.4: Eye diagram of received signal when DSB used at 80 km SMF.....	37
Figure 4.5: BER of SSB and DSB when 130 km SMF used.....	38
Figure 4.6. OSNR vs BER of SSB and DSB when 130 km SMF used.....	39
Figure 4.7. Eye diagram of received signal when SSB used at 130 km SMF.....	40
Figure 4.8. Eye diagram of received signal when DSB used at 130 km SMF.....	40
Figure 4.9: Eye diagrams of OCS at WDM-PON 80 km SMF.....	43
Figure 4.10: Eye diagrams of SSB at WDM-PON 80 km SMF.....	44
Figure 4.11: Eye diagrams of DSB at WDM-PON 80 km SMF.....	44
Figure 4.12. Optical spectra for one channel of WDM when 64-QAM used.....	46
Figure 4.13. Optical spectra for one channel of WDM when 16-QAM used.....	47
Figure 4.14. Optical spectra for one channel of WDM when BPSK used.....	47
Figure 4.15: Received signal constellation of 16-QAM after 40 km SMF.....	48
Figure 4.16: Received signal constellation of 64-QAM after 40 km SMF.....	49
Figure 4.17. OSNR vs BER of 16-QAM after 40 km.....	51
Figure 4.18. OSNR vs BER of 64-QAM after 40 km .....	51
Figure 4.19: Received signal constellation of 8-PSK after 40 km SMF.....	52
Figure 4.20: Received signal constellation of 16-PSK after 40 km SMF.....	53
Figure 4.21 OSNR vs BER of the received signal when 8-PSK and 16-PSK used at 20 Gb/s.....	54

## **List of Tables**

Table 4.1: Q-factor of SSB and DSB at different SMF length.....	41
Table 4.2: Q-factor of DSB, SSB and OCS at different SMF length.....	42
Table 4.3: Q-factor, OSNR and power of the received signal in WDM-PON.....	45
Table 4.4 :OSNR and power of the received signal with different modulation methods..	50
Table 4.5 : OSNR and the received power with two different order of PSK.....	54

## **Chapter One**

### **Introduction**

The growth in broadband services during the last few years is related to its facility in use and its mobility. This thesis contains five main chapters. Chapter 1 includes a concise history of modern telecommunication systems, a short explanation of broadband wired access networks, the problem statement, and the methodology.

Chapter 2 consists of short explanations about PON types, such as TDM-PON and WDM-PON, and a description of passive optical network operations. Chapter 3 includes two systems that are used differently and that have been applied to WDM-PON. The first part of Chapter 3 is an RoF overview and the second part addresses OFDM at the end of the chapter. Simulation, designs and discussion results are the main contents of Chapter 4. The conclusion and the future work section conclude this thesis in Chapter 5.

## **1.1 Background of Modern Telecommunications**

Communication at a distance or telecommunication has been very critical to humans since several centuries ago when communication consisted mostly of letters. In 1793, a serious visual communication system was invented by Claude Chappe, a Frenchman who tried to connect several devices in a series [1]. These devices worked as telephones in a bounded area with a distance of 10 km between the sender and the receiver. Later, in 1820, Hans Christian sparked developments in telecommunication systems by discovering the relationship between electricity and magnesium [2]. Years later, Michael Faraday discovered the electricity which is behind each development in modern telecommunications.

Since Faraday's discovery, telecommunication systems have developed and expanded to connect the world. Transmission voice data was the only task that telecommunication systems offered until the invention of the internet in the 1960s. In the early years of usage, the internet was only used by companies for sending and receiving emails. In the early 1990s, the World Wide Web made the internet an essential part of the humans' lives [3].

Today, multimedia and digital communications have become essential for many people around the world. Using phones is not only limited to talk as in the past. Now, people use their phones for checking email, searching the web, and downloading videos. This development in human usage of telecommunications requires a high bandwidth. Meeting these customers' needs requires advancement in the infrastructures of the communication systems [1].

## **1.2 Broadband Wired Access Networks**

Several broadband wired access networks are used for providing high speed internet access and three dominant services: data, voice, and video. A digital subcarrier line (DSL) is provided by either a television or telephone company as a solution to providing enough broadband services. Using traditional wires makes coping with an increase in demand very difficult, principally with the increase of high definition videos. To account for this difficulty, single mode fiber (SMF) has been used. One of SMF's fundamental features is providing a vast bandwidth, besides its ability to travel a long way. Connecting every single user, whether residential or business, by using a SMF is called Fiber to Terminals (FTTs). By supporting passive optical networks (PON), FTT networks have shown their efficiency and reliability to expand the bandwidth [4][5][6].

### **1.2.1 Copper-Based Access Network**

An efficient way of transporting high bandwidth data to the end users is by using DSL technology which works over telephone lines. The frequencies used by the telephone lines have to be divided into two elementary bands in order to create the DSL connection. Those two bands are occupied by data and voice. Here, data will get no less than 80 % of the voice service's capacity.

The bandwidth limitation in a copper-based line has been considered as a one issue. To overcome this issue, multi-level transmission methods such as quadrature-amplitude modulation (QAM) and discrete multitone (DMT) are highly recommended. However,



using these two modern technologies will not overcome the transmission distance restriction.

Coaxial copper cables are another technology used in network structures. These types of cables have a similar function to DSL, but they can transport larger bandwidths. In order to send digital video and data signals via coaxial cables, 64/256 QAM modulation has been used [7]. To expand the transmission distance, SMF is added to make a hybrid of coaxial and optical cables that can transport both digital and analog signals. Taking advantage of the existing traditional infrastructure for transmitting digital data is an advantage of DSL and coaxial cables. On the other hand, transmitting over long distances, which demands electrical power, is one of the drawbacks of these technologies. Moreover, these options require more electrical power and require adding extra equipment which adds extra cost.

### **1.2.2 Optical Fiber Access Networks**

Reducing the loss and the expansion of bandwidth capacity are two fundamental features that SMF has been addressing in the last decades. To meet the future demand for the broadband service, SMF has been used in the installation of FTTH broadband infrastructures. FTTH systems can be either active or passive optical networks. Active optical networks require electrically powered devices in order to deploy the signals. As a result they cost more than the passive optical networks. Absence of any active elements from the central office (CO) to the end user gives us the other type of FTTH, which is called the passive optical network (PON).

PON is defined as the distribution from a point to several networks structures that contain an unpowered splitter to divide one point into multiple points at the CO [8]. A PON requires less fiber and CO equipment than with the active network. Having a point to multipoint in their structures, PON demands multiplexing devices for combining and splitting the signals. Several types of multiplexing techniques such as time division multiplexer TDM, wavelength division multiplexer, and subcarrier division multiple access SCMA are mostly used in PON. In PON, two popular multiplexing techniques are used, TDM-PON and WDM-PON. In the PON network there is an optical network termination (ONT) that is controlled by the service's provider. Each ONT is connected to a passive optical splitter in TDM-PON or to a wavelength division multiplexer in WDM-PON [9]. The power splitter in TDM-PON splits the signal downstream into several signals as needed. Each separated signal is connected to optical network units (ONUs) at last end user as in Figure 1.1

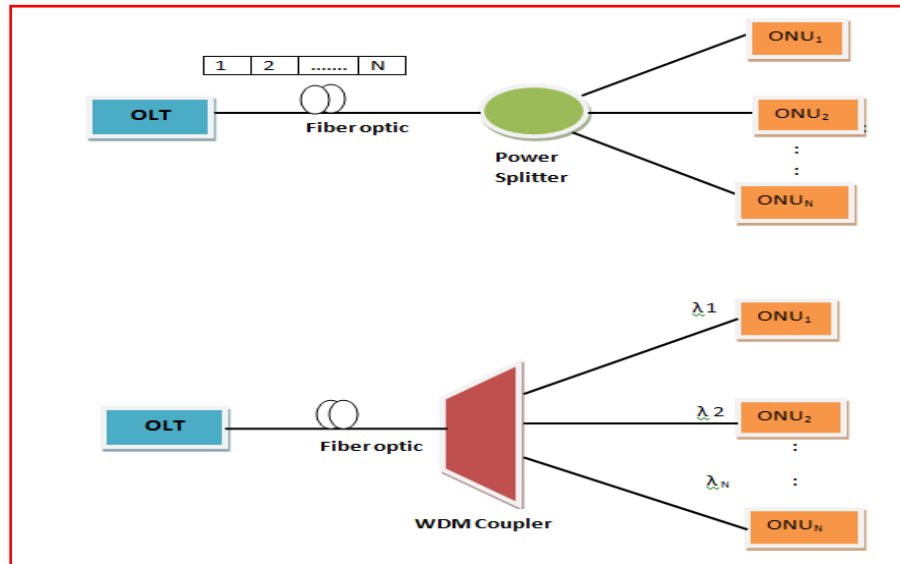

Figure 1.1 Architecture of a) TDM-PON b) WDM-PON

WDM-PON networks have shown their ability to provide a large bandwidth and maintain the quality of signal to the end users. Instead of using passive optical splitters as in TDM-PON, array waveguide gratings (AWG) are used in WDM-PON for multiplexing the wavelengths of the upstream and demultiplexing the downstream wavelengths [10].

### **1.3 Problem statement**

Providing broadband service by any of traditional systems such as by coaxial cable or DSL has shown its ability to provide high bandwidth for the last few decades. The problem exhibited in the traditional system is that of high power consumption which leads to an increase in BER. As a result, the quality of the signal is affected. In a wired communication system, power plays the role in transmitting signals to the end user. Having less signal power means the bandwidth on the receiver side could occupy the end users' service. To overcome this issue, SMF has been inserted in an installation of contemporary communication systems. SMF has proven its strength to maintain the signal's power even over a long distance. In this thesis, PON, which is applied to an RoF that was modulated by different common modulation methods, is used to demonstrate the BER and maintain the bandwidth capacity.

### **1.4 Scope of Research Work**

PON networks could be used to overcome the issues that appear when traditional networks are used for providing a broadband service to the end user. Studies of BER and Q-factor have been recommended to find a comparison between the PON system and

other traditional systems, or between two different designs of PON, in order to maintain the provision of broadband service. When using PON system, the most critical issue in broadband provision is dispersion and attenuation. These two issues appear because of the length of the transmission that affects the signal's power. To overcome these issues, a novel design for the generation of RF signals and multicarrier OFDM to optimize received power for the end user has to be maintained.

### **1.5 Methodology**

The Optiwave version.11 simulation program is used to build bidirectional PON schemes to transmit and receive single carrier RF signals and multicarrier OFDM signals and to compare them to either traditional scheme. By finding and plotting the Q-factor, OSNR, and BER, we can easily find a construct by sending those two types of signal via a regular communication system or via PON system. Two significant measurement methods have been used, the eye diagram measurements in RoF system, and the electrical constellation in OFDM system.

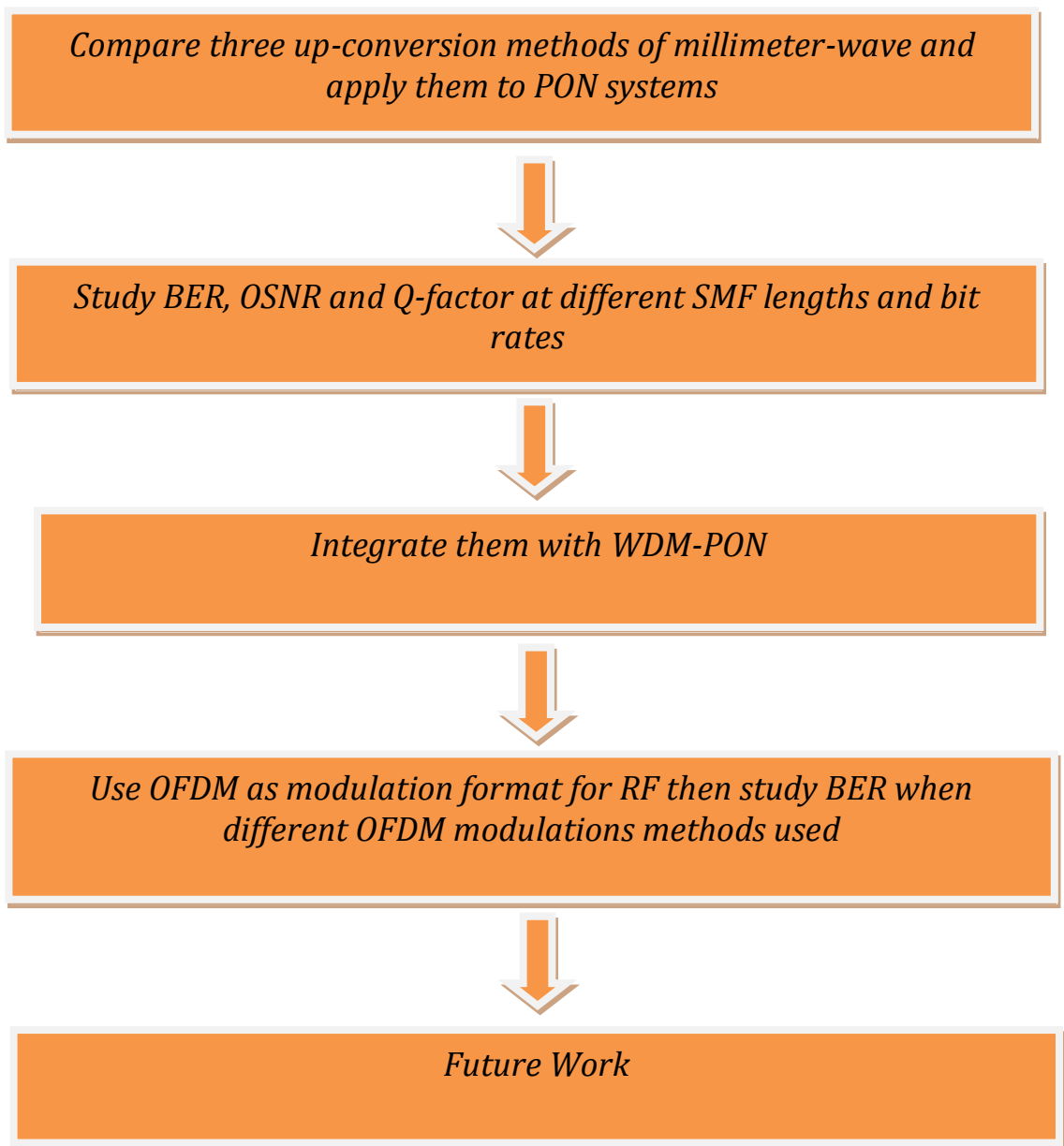

Figure 1.2: Thesis Flow Chart

## **Chapter Two:**

### **Passive Optical Network (PON)**

In this thesis I am focusing on the PON as a sophisticated network for transmitting RF signals to provide broadband services to the end users. PON is a promising option to provide enough broadband services for the future's demands. Now there are many studies and researches finding drastic solutions to meet the broadband demand for sending and receiving high definition video.

#### **2.1 Description of operation of passive optical network**

A PON with diverse components works individually to transport and receive high quality signals. With a PON, streaming down and streaming up are two ways which a signal can go forward and backward via a bidirectional SMF. The downstream schemes are usually more complex than the upstream schemes because the downstream schemes are more heavily used to transmit than the upstream schemes and, therefore, require more components [11]. Moreover, customers use the internet for downloading more than uploading data, voice, or videos. The transmitted and received signals have different wavelengths depending on the type (data, voice, or video) and also whether the signals are going forward or going backward.

### **2.1.1 Downstream link**

The downstream link is designed to be a way through which transmitted signals travel from the CO or ONT to the end user or ONL. At the ONT, the voice and data compound in one frame when preparing for transmission. However, the video signals transmit individually in one frame. This group of frames has been transferred into signals. These signals distribute to the end users via SMF branches which are either unidirectional or bidirectional SMF [12]. Coupling a certain number of those branches without needing any power for regeneration of signals can be done by using optical splitters. The responsibility of the optical splitters is to receive the signals from ONT or CO and send them to ONLs or to the end users. Sending signals to the end users has been demonstrated by TDM which works to send the signals in different times. Besides the differences in time, the signals' wavelengths have to be different in case two or more signals are sent at one time [13-15].

### **2.1.2 Upstream link**

The direction of the information from the end users to CO is called the upstream link. As with the downstream link, data and voice information are compounded in one frame. However, the video information stays indivisibly in one frame. As in the downstream link, information moves backward through the same SMF, and passes through the optical splitters in which the signals will be collected in this direction. TDM in this link is functional when sending information from multiple points of end users via one

single channel to the CO. Unlike the downstream link, the upstream link uses one wavelength which is usually chosen to be 1310 nm [13-15].

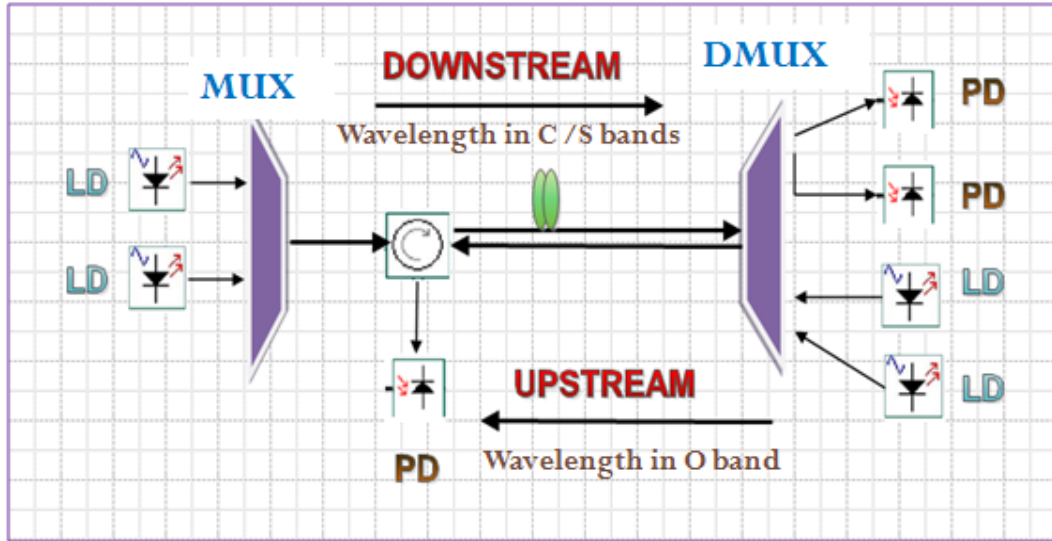

Figure 2.1: Scheme of two channels bidirectional WDM-PON system

## 2.2 History of WDM

The first paper about the WDM concept was published in 1970, and by 1978 WDM systems were recognized in laboratories [16]. Those early WDM systems were only designed to combine and separate two signals and were very expensive. Now, WDM systems have been improved. In 2011, sophisticated WDM systems could handle up to 160 channels with 1.6 Tbit/s and a total bit rate of 10 Gbit/s for each channel. Recently, WDM has played a role in the development of the telecommunications companies because of the capability of expanding the bandwidth capacity. Another impact of WDM is, instead of installing SMF for each single signal from the central office to the end user



or from the end user to the central office WDM needs one SMF to send up to 160 channels.

### **2.3 Overview of WDM**

In the 1980s the optical fiber links contained a number of point to point connections. Each one of those links had one optical source, photodetector, and optical fiber that joined the link's terminals [14]. Moreover, these basic links that had different optical sources needed unique, individual optical fiber which would cost a lot. To overcome this issue, wavelength division multiplexing was invented in order to reduce the number of used optical fibers and to expand the capacity of positioned point to point links. Implementing a WDM design in order to increase the capacity that allows a certain number of wavelengths to be compounded has been the dominant demonstration of WDM. The modern WDM is capable of sending tons of optical signals, which are sourced by optical laser sources, with very narrow spacing wavelength between each two signals. Not only are the wavelengths allowed to be different, but WDM also allows each channel to have its own format by using different data rate [16]. WDM systems are divided into two types depending on the wavelength's categories and the number of channels. These two types of WDM are coarse WDM, CWDM and DWDM. [14]

### **2.4 WDM standards**

Because of its essentiality to carrying frequencies, WDM standards have been implemented for optical fiber by the international telecommunication union or ITU. The

spacing frequencies are the main aspect that ITU controls and fixes. ITU has released recommendation for WDM systems, CWDM, or DWDM. In 2002, ITU published an appropriate recommendation for DWDM which is G.694.1 Operation of WDM either in S, L and C bands whether in WAN or MAN networks was one of these recommendation aspects [16]. Year after, 2003, G.694.2 was released for CWDM which has a spectral grid from 1270 nm to 1610 nm with a spacing wavelength 20 nm Figure 2.2 [14][17-19].

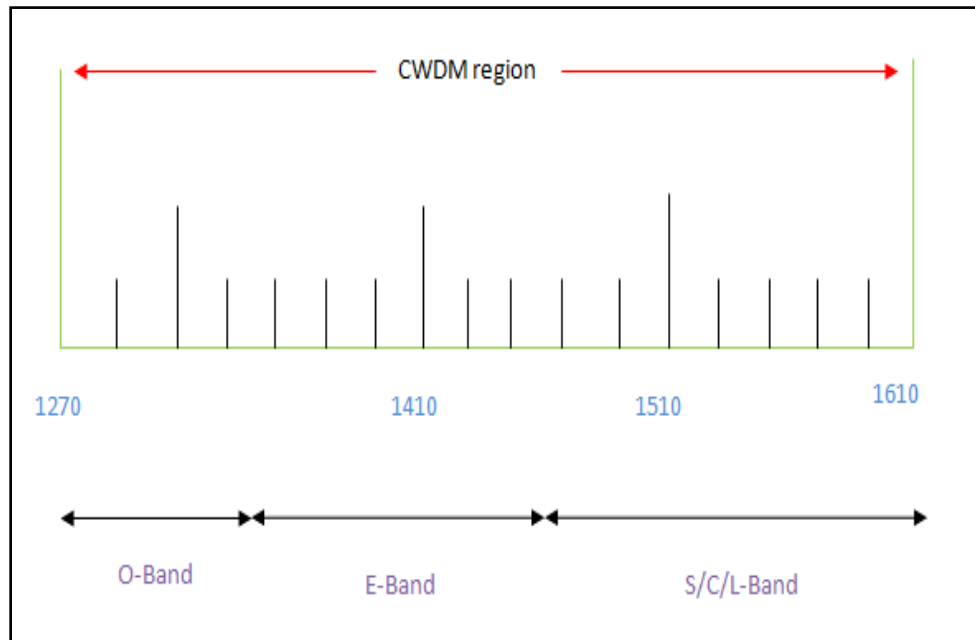

Figure 2.2: Spectral grid of coarse wavelength division multiplexing CWDM

## 2.5 Overview of WDM-PON

The WDM-PON expands the qualifications of PON. Instead of using more than one optic fiber in the original PON to distribute the transmitted signals from the CO to OUNs, WDM-PON reduces the usage of fiber optics in the system. Moreover, since

WDM-PON distributes the received signals among multi users, each user gets his/her own wavelength, increases the privacy in the PON systems besides the high reliability and less maintenance that WDM-PON systems have [20]. As a drawback of WDM-PON, costs of WDM elements have been part of the challenges that WDM-PONs face. Even though the prices of WDM have been reduced tremendously, they still are not affordable.

In WDM-PON, arrayed waveguide grating (AWG) is a key element in many designs. The traditional WDM coupler has one input and N output channels according to their wavelengths as shown in Figure 2.3 [8]. The original AWG router contains two star couplers linked together. Unlike the traditional WDMs, AWG has N number of inputs that are faced by N number of output ports. The input ports in AWG have signals with multi wavelengths. Shifting any of the inputs from one port to another leads to a shift in the demultiplexed output to the next port without any losses that might happen in WDM [13].

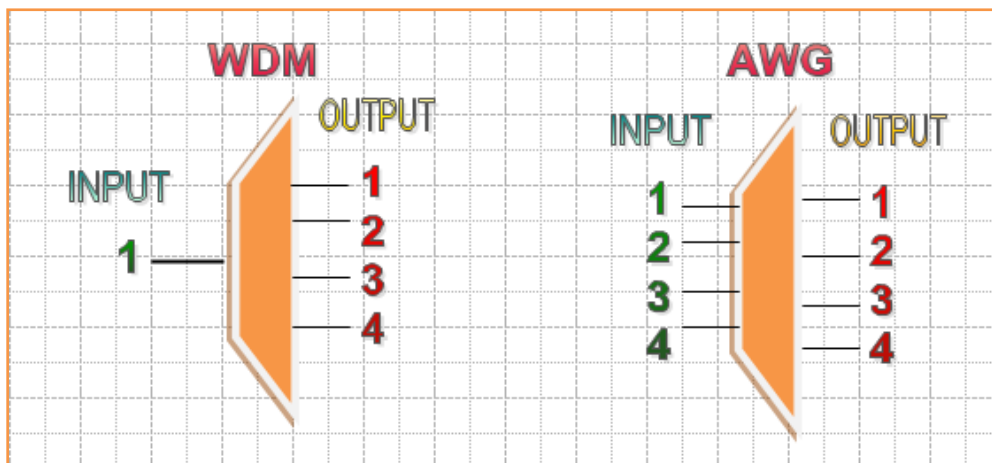

Figure 2.3: Comparison between WDM and AWG

## **2.6 TDM-PON vs WDM-PON**

The common aspects in the two structures, from the OLT in CO to the end ONUs, active elements are completely disappeared. The fundamental element in the TDM-PON is the optical power splitter . Broadcasting a signal from OLT or CO have to pass through power splitter which distributes the received signal to each individual ONUs. Multiplexing signals from diverse ONUs are in the time domain. By using the address brand of the signal, each ONUs can distinguish data.

In WDM-PON the essential element is a passive WDM coupler. From the CO, a WDM coupler multiplexes a number of signals and each one of them has its own wavelengths. At the ONUs side, each ONU takes its own wavelength. Because ONU knows the wavelength that it will receive, WDM-PON systems have more privacy than TDM-PON. In contrast, the high cost of WDM elements is one of the WDM-PON drawback [8][21][22].

## **Chapter Three**

### **Different Modulation methods of RoF in PON**

#### **3.1 RoF Overview**

Transmitting radio frequency signals from the CO to the Remote Antenna Units (RTU) via optical fiber is known as RoF technology. In such narrowband communication systems, before sending the signals to RTU, all the RF signals processing such as carrier modulation have to be performed at CO. Centralizing all the RF signals processing in CO and sending them via optical fiber is one of the fundamental features of RoF signals. Further, it helps to share the same equipments and simplifies the system operation and maintenance. The optical fiber offers low signal loss which depends on the wavelength of the signals, 0.3 dB/km for 1550 nm, and 0.5dB/km for 1310 nm. The responsibility of doing amplification functions and the optoelectronic conversion is the main duty of RTUs which is one of the RoF impacts [23].

As in each transmission systems either in free space or by line of the microwave signals with high frequencies, the loss is problematic. The losses in the free space transmission system are related to the increase of the frequency with the absorption and the reflection. However, in the transmission line system the loss is due to the impedance of the lines with frequency. Transmitting and distributing RF signals over a traditional

line needs more regenerating equipment to avoid the losses. The alternative solution to reduce the losses and enhance the transmitted and received RF signals is by using optical fiber or RoF [24].

Promotion of the bandwidth capacity is one of the issues that need to be fixed; however, optical fiber offers a substitute solution to solve that. There are three main wavelengths that are mainly used in the transmission, 850 nm, 1310 nm and, 1550 nm. Therefore, several factors have the capability of expanding the bandwidth of the optical fiber, including the capacity of the low dispersion devices, such as the Erbium Doped Fibre Amplifier (EDFA) and other the multiplexed devices.

Moreover, the RoF systems disappearance of the electromagnetic interface (EMI) is related to the immunity that optical fiber offers. Besides the elimination of EMI, installation of the RoF systems has shown an economic impact and low maintenance. Supplementing the RTU systems by adding optical fiber helps to reduce the power consumption.

### **3.2 Generation methods of millimeter-wave signals over optical links**

One promised solution for demonstrating the wireless communication system is up converting the baseband signals. As a one performance of up conversion, the baseband signal to millimeter-wave carriers prepare for broadcasting in the space. Even though transmitting the baseband signals via optical fiber helps to reduce the dispersion, the up conversion process at the COs needs more equipment for generating millimeter-wave carriers and mixing them with LO. Developing the millimeter-wave generation methods

has encouraged many groups to find efficient ways to support wireless telecommunication systems. Conventionally, there are four different methods for producing millimeter-wave signals with intensity modulation: intensity modulated and direct detection, external modulation, harmonic modulation and optical heterodyning [25][27].

### **3.2.1 RF signal generation by intensity modulated and direct detection (IM-DD)**

The straight forward way of RF generation is by modulating the intensity light of the laser source and directly detecting by a photodetector. There are two strategies to modulate the light signal. The first way is immediate modulation by which RF immediately modulates the current of the laser source. Connecting a Mach-Zehnder Modulator (MZI), which works as an external modulator, to a continue wave laser (CW) is the second strategy as shown in Figure 3.1. Modulating the original RF to be distributed is the common feature that both strategies have. After the modulation stage at the transmitter side, the signals have to be transported over optical fiber, which is usually chosen to be SMF, before being detected by the photodetectors at the receiver side of the system [23][25].

The simplicity and the linearity are two impacts of using IM-DD, because of having simple design and low dispersion [25]. Furthermore, the transporting to any of the modulation formats of RF signals is because the optical fiber acts as either attenuator or amplifier. On the other hand, the failure to support mm-wave systems with high frequency is one of the drawbacks of IM-DD system. Moreover, generating mm-wave

signals with high frequencies requires the same frequencies for the modulating signals. The other drawback of this method is the limitation of the modulation bandwidth [26][27].

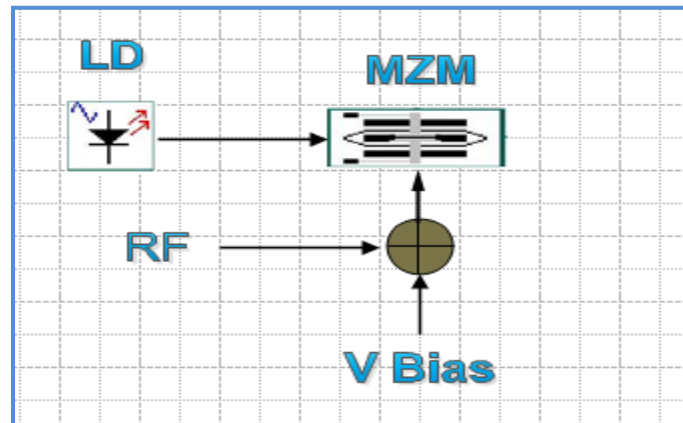

Figure 3.1: simple scheme of IM-DD modulation

### 3.2.2 External intensity modulation

Modulating intensity externally to demonstrate the conversion of radio signals via SMF at RF carrier is another simple method. As a two up-conversion methods for millimeter-wave, double sideband (DSB) and single sideband (SSB) methods are used to demonstrate the generation and the transmission of millimeter-wave at RF carrier. DSB modulation is mostly used for short distance transmission because of the dispersion effects in fibers [Figure 3.2]. However, SSB modulation helps to transport RF signal through long transmission distance. In SSB, a dual-arm MZM modulator has to be used to modulate two local oscillators (LO) which have the same frequencies with  $90^\circ$  phase



shift [Figure 3.3]. Those two methods, when they are multiplexed by using WDM and transmitted via SMF in PON, they could not transport RF signals farther than a single channel [7][28][29].

To overcome the multiplying effects, optical carrier suppression (OCS) is used as another up-conversion technique. In this method each channel of WDM has the same scheme of OCS [Figure 3.4]. Besides the easy integration of OCS with WDM-PON and the high reception sensitivity, RF signals entail a low bandwidth in OCS modulation [7][30]. The voltage bias in OCS is double that of the voltage bias in SSB and DSB.

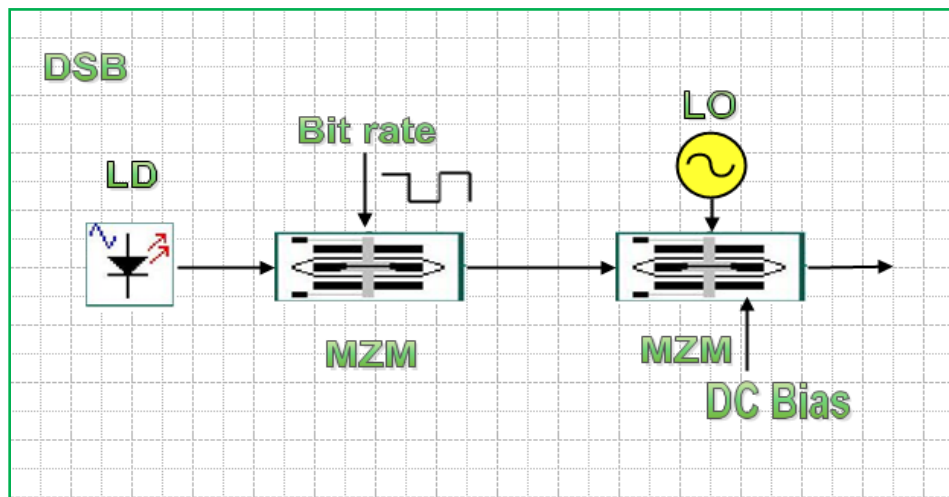

Figure 3.2 :Optical up-conversion using DSB

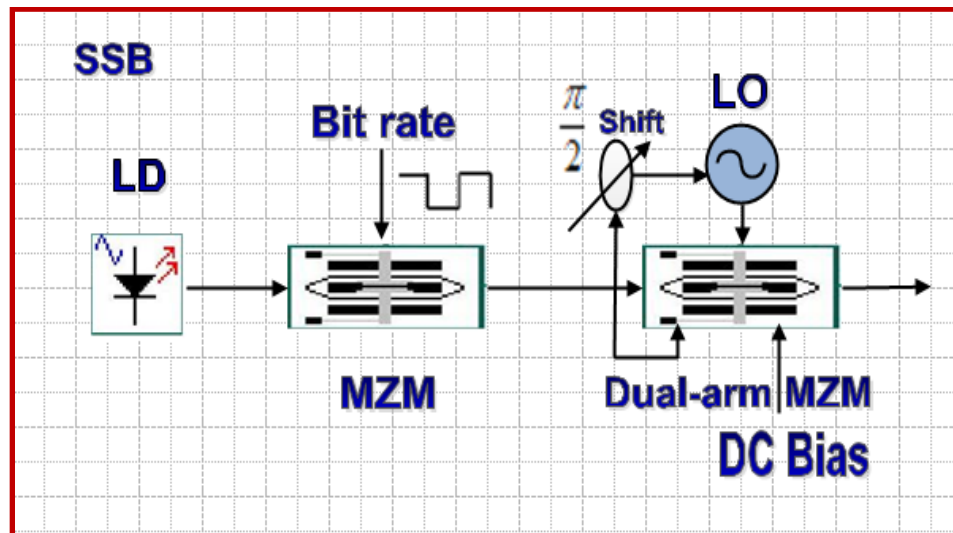

Figure 3.3 :Optical up-conversion using SSB

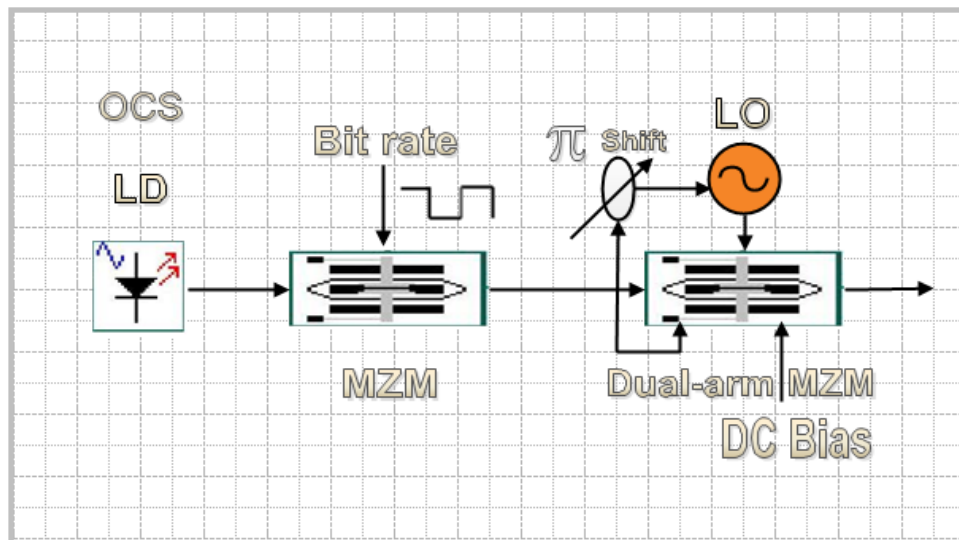

Figure 3.4 :Optical up-conversion using OCS

### 3.3 RoF-PON system configuration

In any simple RoF system demonstrating RF signals is the main critical process to increase the ability of the transmission and meet the bandwidth demand. Increasing the length of SMF or expanding the bandwidth of millimeter-wave causes a suffering for a received signal from dispersion or attenuation. As mentioned previously, three production methods of millimeter-wave have been used then sent via PON system through different length of SMF. Figure 3.5 shows a novel design of a bidirectional PON system. The upstream link starts from the continuous wave laser (CW), and then bidirectional SMF is used to connect the ONL to ONUs. Before reaching ONUs, power splitters are used to separate the transmitted signals into desired numbers of signals. Each output of the power splitter is connected to one ONU via a short SMF. Having SMF from the ONL to the end ONU leads to promote the bandwidth at the receiver side. In this system each ONU represents to be RTU which takes electrical signals. Photodiode detectors are used to reconvert the optical signals to electrical signals.

To insert RFs for any one of chosen methods, MZMs have been used to modulate the LO signals with laser sources CWs. In the case of using two LOs to produce RFs signals, each LO has its phase shift as in SSB and OCS, and dual arm MZM has been chosen. The upstream link contains several numbers of time delay which work to delay the transmitted signals from ONU to ONL in order to avoid the confliction between the down link signals and upstream signals. In another trick to avoid the conflict between up and down stream, two ranges of wavelengths usually are chosen which are 1500s and

1300s. Similar to the end of the downstream links, upstream links have photo detectors at the end of the links to reconvert the optical signals to electrical signals [Figure 3.6].

For transmitting more than one signal via one bidirectional SMF, WDM is used. Each channel of WDM has a specific wavelength. These wavelengths of all channels will be multiplexed at WDM before travelling through SMF then demultiplexed by WDM demultiplexer in order to separate and distribute them among the end users [30-34].

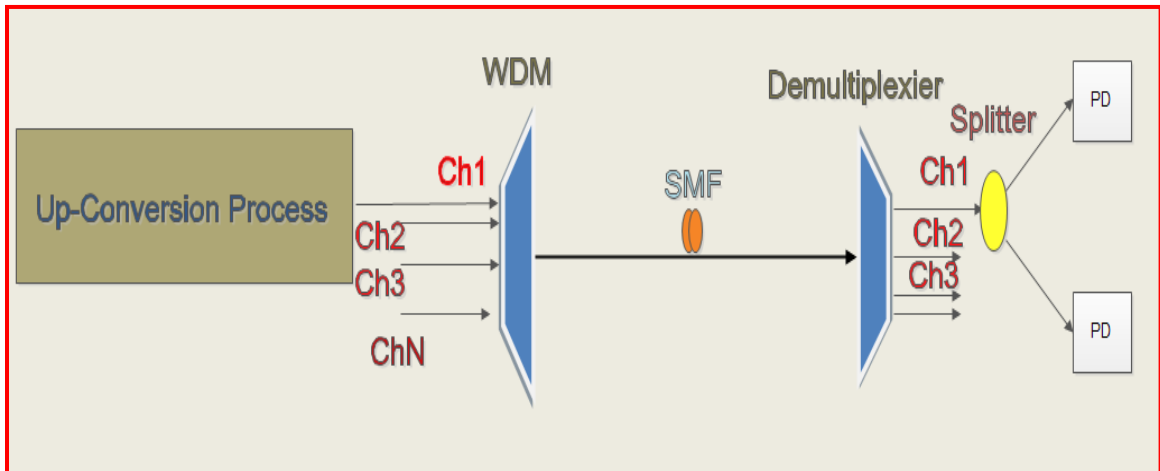

Figure 3.5. Architecture of WDM-PON system for production and transmission RF signal

### 3.4. OFDM Background

In the traditional parallel data system, the signal bandwidth can be split into a number of sub-channel frequencies without overlapping between two sub-channels. Modulation each single subchannel is individually with a split symbol then they will be frequency multiplexed. Multiplexing sub-channels helps to stay away from the overlapping that might cause inter-carrier interface ICI. In the mid 1960s, an idea was

brought to eliminate the incidence of ICI even with subchannels overlapping in frequency division multiplexing FDM. Orthogonalizing Mathematically the subchannels is required to realize this idea. To achieve the orthogonality, orthogonal frequency division multiplexing OFDM was invented theoretically.

The first appearance of OFDM in telephone lines transmission was in 1980 because of its ability to reduce the process complexity and demonstrate the Fast Fourier Transformation FFT. Several years later, usage of OFDM expanded to be a critical component in building the mobile communication systems and broadcasting schemes. Since that date, OFDM has been developed until it has become an essential part of the telecommunications standard [35][36].

### **3.5 OFDM overview**

OFDM is an encoding digital data method for several carrier frequencies. Compared to single carrier transmission systems, OFDM supports the high data transmission rate. OFDM is functional equipment that has been used in many communications' applications such as broadband internet access and 4G mobile communications. Using the RF spectrum by OFDM functionally is required for the transmission of the data in multiple frequencies. Coping with several channel conditions is one of the fundamental impacts that OFDM offers and makes OFDM preferable to single carrier frequency. Besides that impact, controlling the orthogonality of the systems. Offering the orthogonality for the systems and having an enough strength to transmit a high data are the two important advantages that make OFDM a functional

equipment in the modern communications systems. Use of OFDM modulation format in RoF systems has showed its capability to meet the broadband future's demand [1][7][35].

### 3.6 OFDM modulation

Using OFDM in receiver and transmitter schemes requires modulating and demodulating of transmitted signals. Several modulations techniques are used, however, two methods are commonly used which are QAM and PSK. Figure 3.6 shows a block diagram of the basic technique for modulation and demodulation. The block diagram contains two main parts which are the transmitter and receiver.

At the transmitter side the process starts with a mapping technique by using either QAM or PSK modulations methods. After serial to parallel conversion, streams pass through IFFT. In order to protect the signals from the overlapping, a protector period is added before the parallel to serial conversion [37].

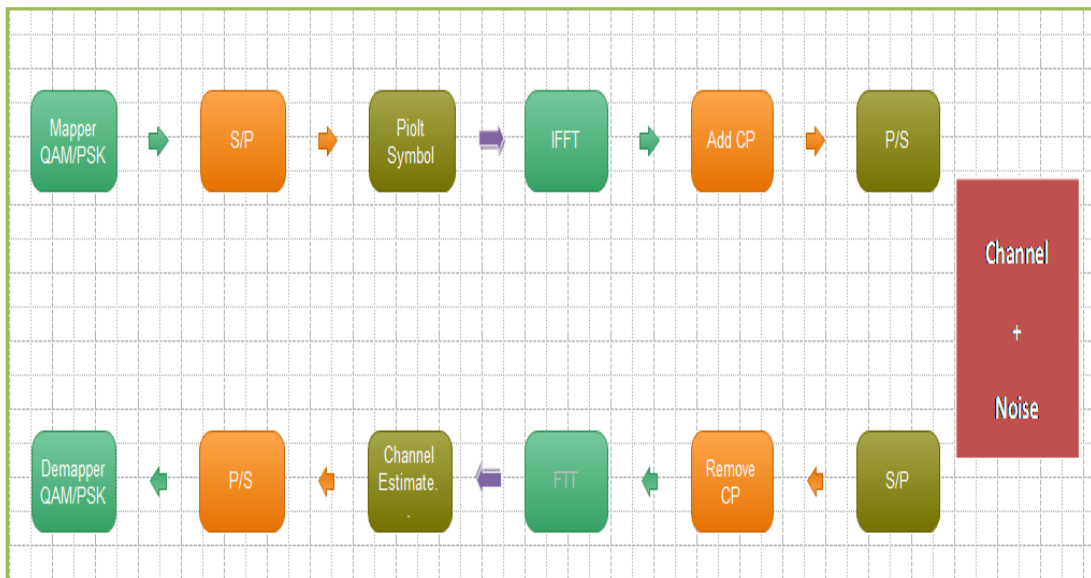

Figure 3.6: Block diagram of process of OFDM system

At the receiver side the process of the transmission starting with serial to parallel conversion in order to take off the cyclic prefix is almost the opposite way. Before estimating the step, FFT is used to the signal. Demodulation of the signal either by using QAM or PSK is the last stage in the OFDM modulation process.

### **3.7 Constellation diagram**

In order to test the quality of the signal in the OFDM, a constellation diagram is used. Each data symbol is represented by a dot in a two dimensional diagram. This two dimensional diagram represents a data symbol as real and imaginary numbers on the x-axis and y-axis respectively. For modulation's types, a constellation diagram has an appropriate format. For using BPSK modulation, a constellation diagram represents only two points as in Figure 3.7. However, using 16 QAM or 64 QAM will present 16 and 64 point in the constellation diagram as shown in Figure 3.8 and Figure 3.9.

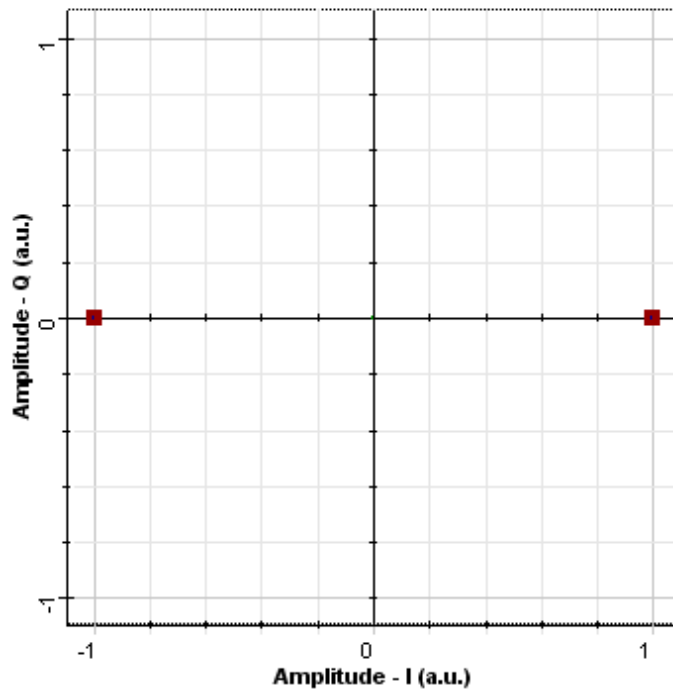

Figure 3.7 : BPSk constellation

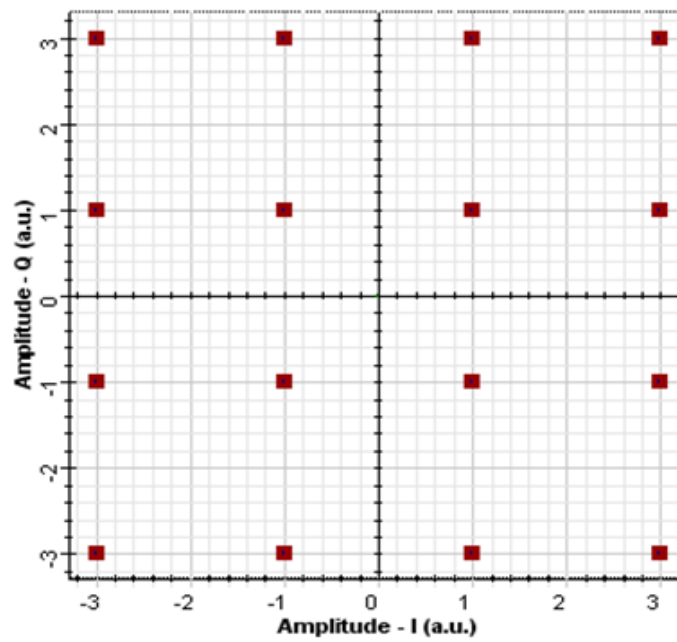

Figure 3.8: 16-QAM constellation



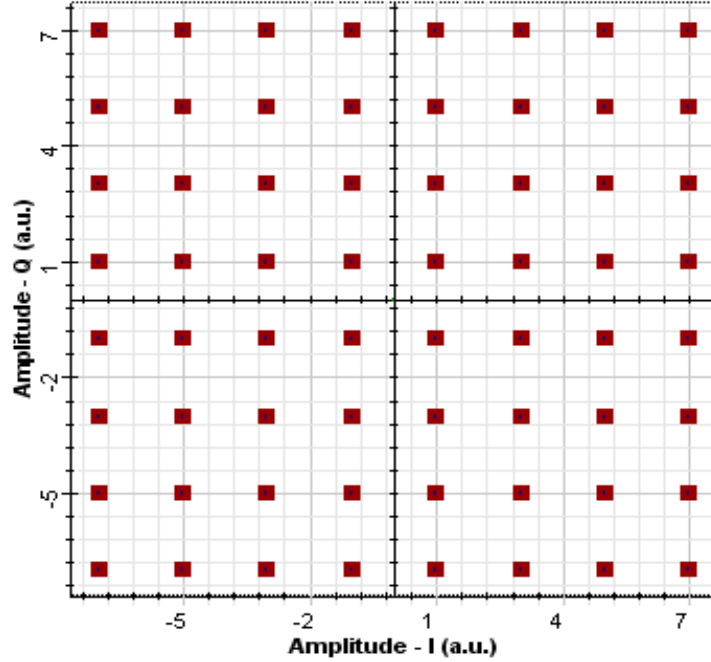

Figure 3.9 : 64 constellation

### 3.8 M-ary PSK and QAM

PSK and QAM are considered to be the most common modulation techniques for OFDM. The difference between these two methods is that the PSK scheme transfers the data by changing the phase of the reference signal while the QAM scheme transmits data by modulating the amplitude of the reference signal. The common feature between these two schemes is that they are both use two DSB signals carriers[1][7].

#### 3.8.1 PSK modulation and demodulation process.

The varying phase of the modulated signal builds a subtle connection between the analog modulation and the PSK. The modulated signal can be derived from equation 3.1

$$\varphi_{PSK}(t) = A \cos(w_c t + \theta_k) \quad (3.1)$$

Where  $\theta_k$  is a constant phase and  $kT_b \leq t \leq kT_b + T_b$ , we can rewrite the PSK signal as

$$\varphi_{PSK}(t) = a_k \cos w_c t + b_k \sin w_c t \quad (3.2)$$

Where  $a_k = A \cos \theta_k$  and  $b_k = -A \sin \theta_k$ .

By applying some amendments to equation 3.3, the general form of PSK is given by:

$$\varphi_{PSK}(t) = a_m \sqrt{\frac{2}{T_b}} \cos w_c t + b_m \sqrt{\frac{2}{T_b}} \sin w_c t \quad 0 \leq t \leq T_b \quad (3.3)$$

The demodulation technique of BPSK depends on the binary digit. For instance, if the digit is 1 it will be transmitted by a pulse  $A \cos w_c t$ . Otherwise, it will be transmitted by a pulse  $-A \cos w_c t$ . Similar to the DSB subcarrier, an envelope detection method could not be applied in BPSK because 1 and 0 stay constant in the envelope. The received signals at the decision box have been evaluated, and if the received signals are positive then it will be detected as 1. Otherwise, it will be detected as 0.

### 3.8.2 Quadrature Amplitude Modulation (QAM)

As compared to the SSB subcarrier, QAM can be generated accurately, which is considered to be the most important feature of QAM. Figure (3.10) shows a QAM scheme operation which works by transmitting two DSB signals with the same carrier frequency having a  $\frac{-\pi}{2}$  phase shift between them. The phase shifter delays the phase of

an inserted sinusoid by  $\frac{-\pi}{2}$  before they are added together to give the QAM signal as in 3.4.

$$\varphi QAM(t) = m_1(t)\cos w_c t + m_2(t)\sin w_c t \quad (3.4)$$

The added modulated signal occupies one band before it divides at the receiver into two local carriers  $x_1(t)$  and  $x_2(t)$  as in the following 3.5 and 3.6.

$$x_1(t) = m_1(t) + m_1\cos 2w_c t + m_2(t)\sin 2w_c t \quad (3.5)$$

$$x_2(t) = m_2(t) - m_2(t)\cos 2w_c t + m_1(t)\sin 2w_c t \quad (3.6)$$

The modulated signals by a carrier of angular frequency  $2w_c$  are suppressed by two low-pass filters at the end of the demodulation stage [1][38].

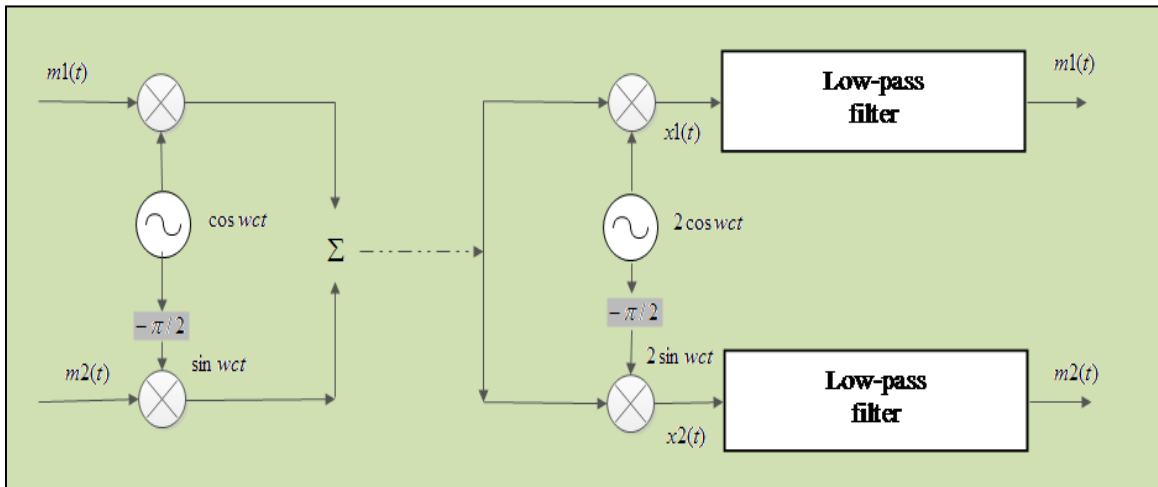

Figure 3.10: QAM or quadrature multiplexing scheme

### 3.9 Trading power and bandwidth

The choice of the M-ary has affected the mood of the interchange between the transport power and the transition bandwidth (SNR). For instance, the transmission

bandwidth in the orthogonal signaling proportionally increases when M increases while the transport power is inversely proportional with the value of M. On the other hand, in the PSK signaling, the transmitted power increases when M increases. However, the bandwidth stays constant. Seeking for an appropriate transmitted power or transmission bandwidth depends on the M-ary choice. For example, acquiring a transition bandwidth recommends using QAM signaling while the orthogonal signaling is recommended when the transmitted power is needed [1].

### **3.10 Bit error rate**

The total number of errors to the total sent bits ratio is defined Bit error rate (BER) as given in the following formula

$$BER = \frac{\text{Number of errors}}{\text{total number of bits sent}}$$

In the PSK or QAM, the M order affects the BER value. That is because the high order of M means transmitting a large number of bits. The increase in the sent bit will likely promote the number of errors, and as a result the BER will increase [1].

### **3.11 OFDM-PON system configuration**

In the OFDM-PON system, four symmetrical channels have been multiplexed by using WDM (Figure 3.8). The key element in each channel in the downstream link design is OFDM. Using OFDM in any communication system requires specific types of modulation to modulate and demodulate the transmitted and received signals such as QAM or PSK. The downstream links start with a Pseudorandom Binary Sequence

(PRBS) which is modulated by QAM or PSK before going to OFDM. Each one of the two OFDM outputs go to pass via a low pass filter before going to the MZM. Output modulated signals from the MZM are multiplexed by WDM before travelling via bidirectional SMF. Before and after SMF, two EDFAs are used to promote the power of the multiplexed signals. After the second EDFA and before the WDM demultiplexer, the optical circulator is used to redirect the down and up stream signals. After passing through the WDM demultiplexer, photo detectors are used to reconvert the optical signals to electrical signals and then demodulate again [39-43].

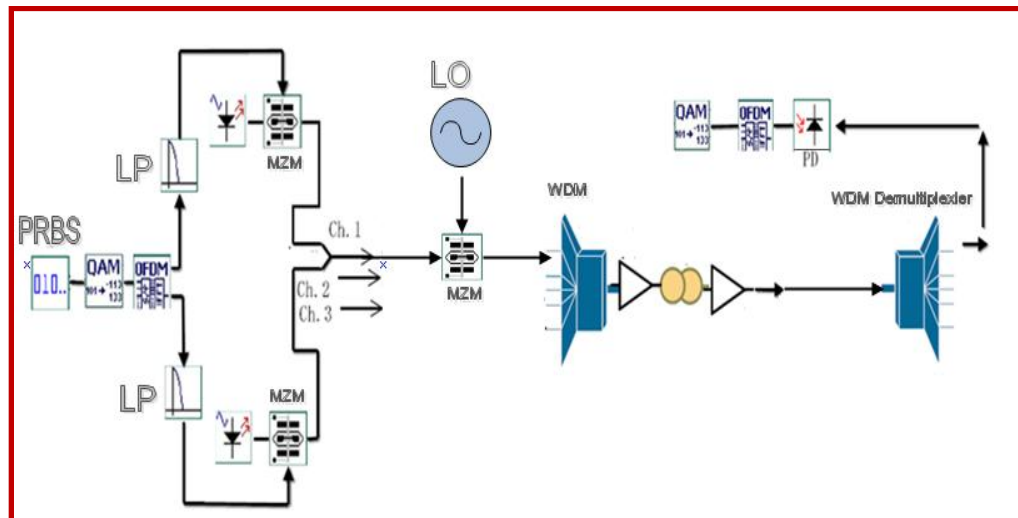

Figure 3.11. Architecture of OFDM-WDM-PON system.

## **Chapter Four:**

### **Simulation Results**

Chapter four includes a study of BER and Q-factors of more than one WDM-PON scheme in order to achieve a maximum bit rate carried via the longest possible SMF length. The two main WDM-PON systems were studied in this thesis. Each one of these systems was analyzed under different parameters with different designs and elements. The common function of these two systems is to improve the transmitted bit rate by using different modulation methods either by a single carrier or multi carrier OFDM modulation formats. In such a single carrier RoF system, three modulation schemes were used to up-convert RF signals and were compared with each other. Studying each method individually in order to find the appropriate method for transmitting RF signals via WDM-PON is necessary.

As an advanced modulation format in RoF, OFDM was used to modulate RF signals in WDM-PON. An analysis of OFDM was focused on different modulation methods for OFDM, such as PSK and QAM.

Before going through the results, a comparison among three different schemes and several parameters are under consideration to analyze the results. BER, Q-factor, OSNR and eye diagrams are the main parameters that help to find a comparison of the

received signals in all three methods. BER is defined as the division of the concerned bits by the total bit rate sent under a limited period of time. The values of BER are should be as low as possible. However, the Q-factor and OSNR values are desired to be high.

#### **4.1 Comparison between two externally modulation methods in RoF-PON**

An optiwave scheme was built to study BER, OSNR, eye diagram and Q-factor at 2.5 Gb/s in RoF-PON system as is shown in Figure 3.5. Production of RF signals by using either DSB or SSB was considered to find a comparison between two of them. Before going through the result, the LO signals frequencies in DSB and SSB as in Figure 3.2 and Figure 3.3 were chosen to be 60 GHz, and the bit rate was chosen to be 2.5 Gb/s. Figure 4.1 shows a plot of received power vs log of BER of DSB and SSB after varying the CW power 10 times from 5 dBm to -5 dBm. When the SMF length is equal to 80 km, the received power in SSB and BER is higher in DSB than the BER of SSB while both SSB and DSB have nearly the same value of received power. The maximum value of log BER in SSB was around -92.47 while the maximum in DSB was less than -30. A low value of log BER leads to a signal with high quality as in both SSB and DSB. In the case of having almost equal OSNR, having a low BER in the SSB is shown in Figure 4.2 is evident. The reason why SSB advances DSB systems is because occupying the both sides of signals in DSB means transmitting signals with 120 GHz bandwidth while in SSB just 60 GHz is necessary. In other words, DSB offers double the bandwidth which increases the dispersion in SMF.

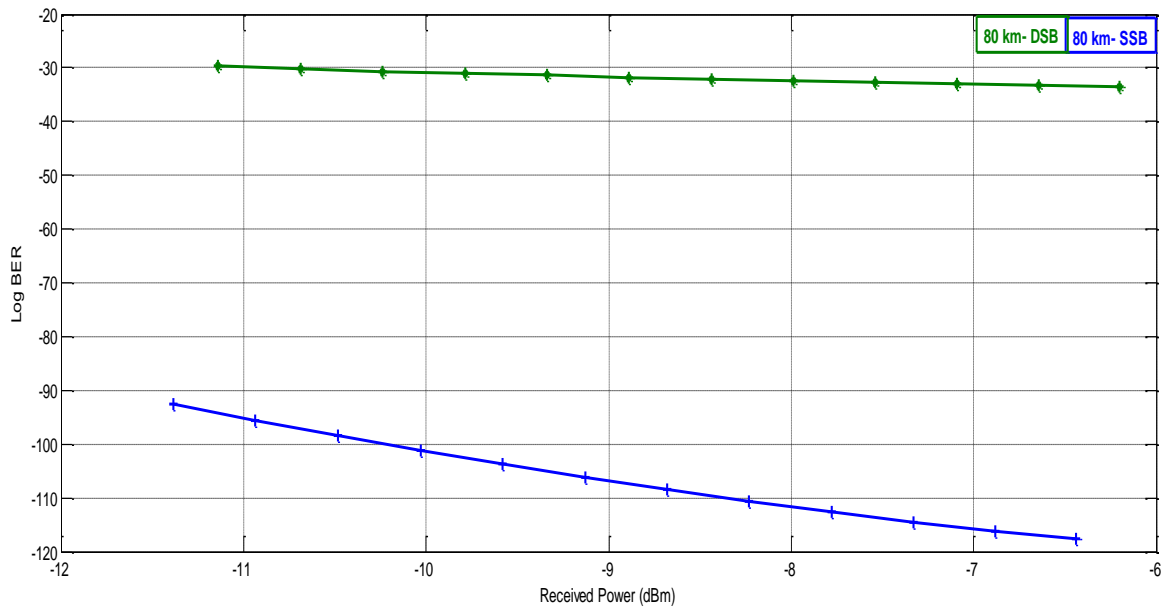

Figure 4.1 BER curves of DSB and SSB when 80 km SMF used

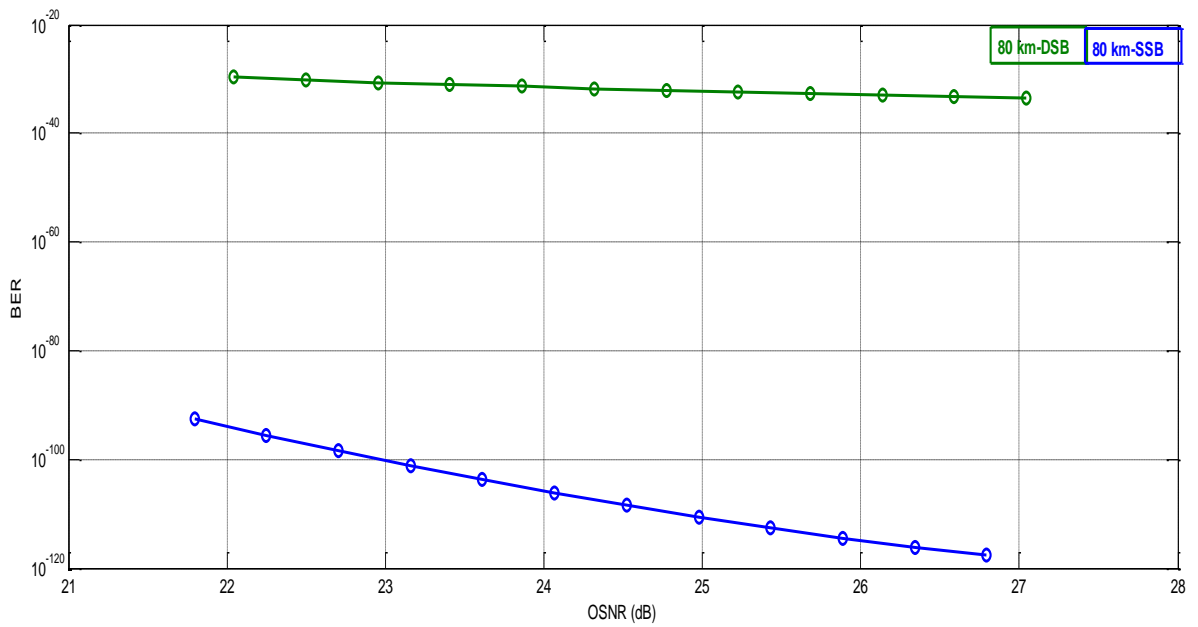

Figure 4.2. OSNR vs BER of SSB and DSB when 80 km SMF used



The other comparison concerns the eye diagrams of the received signal for both DSB and SSB. Figure 4.3 and Figure 4.4 show that the opening eye of the received signal in SSB is bigger than in DSB. Having a big opening eye represents a received signal with high quality which demotes when the penning eye shrinks. Inversely proportional Q-factors increase when BER decreases. The bit rate carried by RF signals needs a high quality of RF signals in order to be delivered with low error.

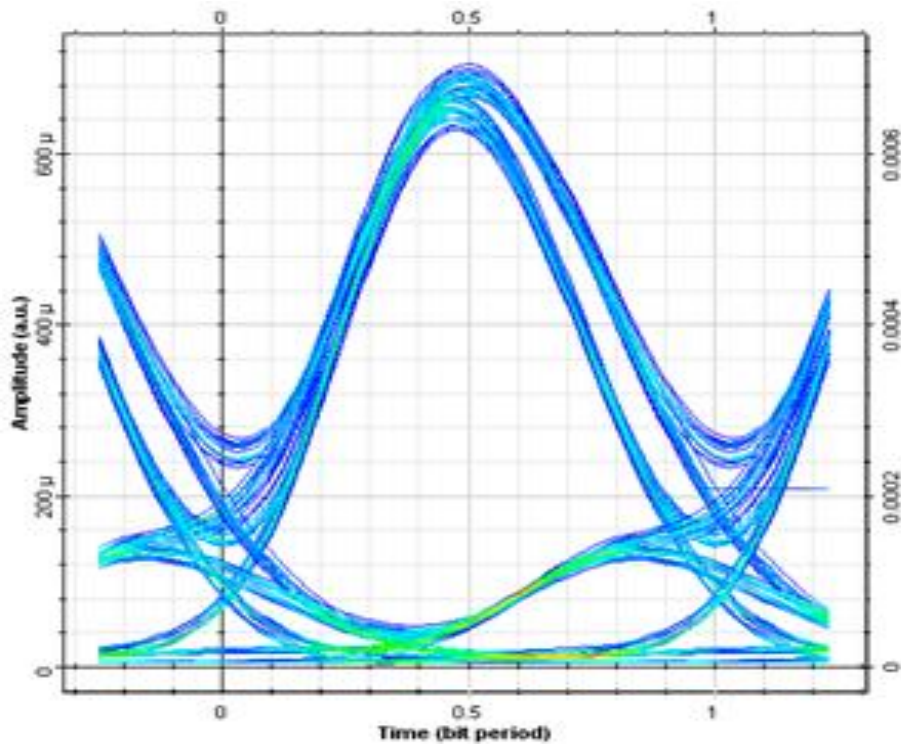

Figure 4.3: Eye diagram of received signal when SSB used at 80 km SMF

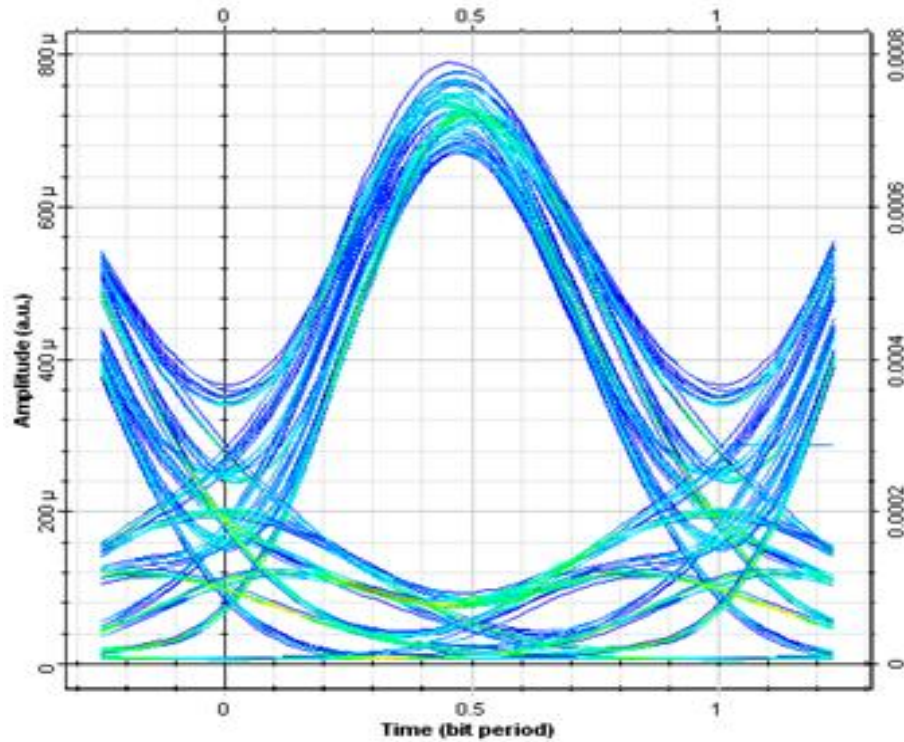

Figure 4.4: Eye diagram of received signal when DSB used at 80 km SMF

It can be clearly seen from the eye diagrams in Figure 4.3 and Figure 4.4 that the Q-factor in SSB is greater than the Q-factor of DSB. Although the Q-factor of DSB is lower, it is still enough to receive a satisfactory signal if we take into account the SMF length. Moreover, RoF-PON system contributes to maintain the quality of the received signal when either DSB or SSB are used to modulate RF signals, which is then sent via 80 km of SMF. The values of BER and OSNR of the received signals show that transmitting signals via PON system, especially for DSB, is suitable even though the BER is higher than in SSB.

By repeating the same procedure at 80 km, the SMF length was expanded to 130 km in order to find the maximum length for transmission RF signals. Figure 4.5 shows that the BER in DSB continues to be higher than the BER in SSB. As SMF length extended by 50 km, SSB and DSB lost around 50 % of their OSNR values. The maximum OSNR in SSB after the extension is around 16.79 dB while the maximum OSNR in DSB is 17.04 dB [Figure 4.6].

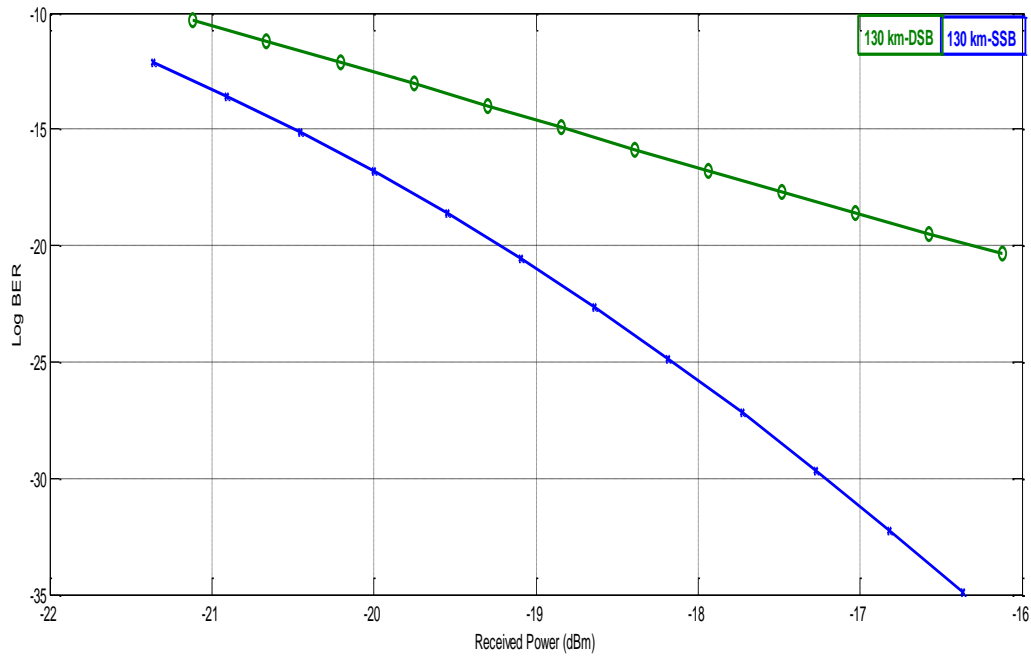

Figure 4.5: BER of SSB and DSB when 130 km SMF used

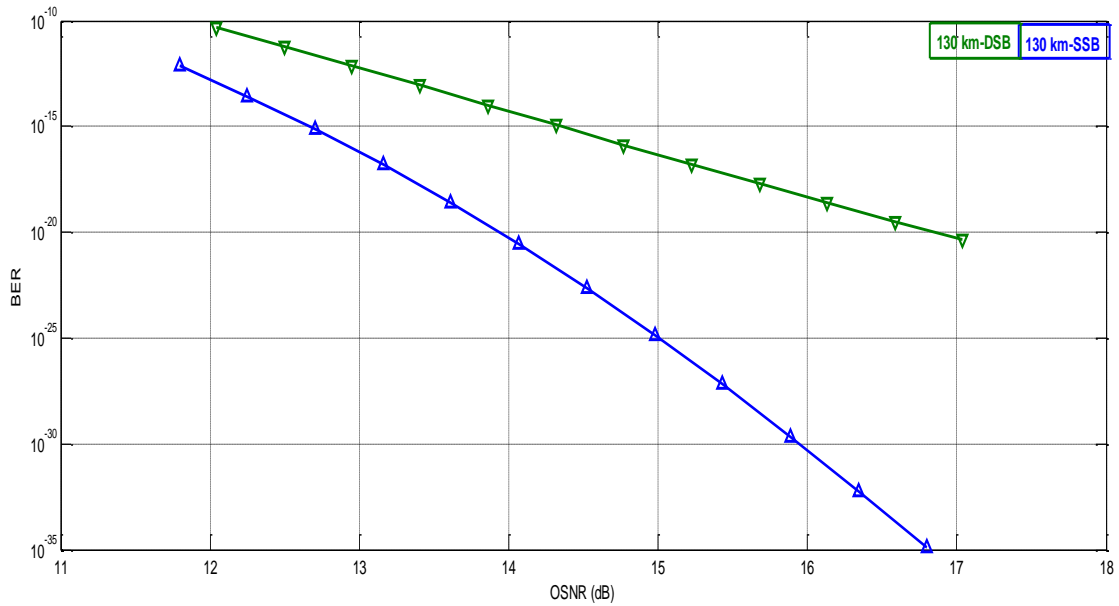

Figure 4.6. OSNR vs BER of SSB and DSB when 130 km SMF used

After expanding the SMF length, the opening eye in Figure 4.7 and Figure 4.8 became smaller and as a result the Q-factor decreased. Having a small opening eye means that the signals are affected by the optical fiber dispersion and attenuation which occur after a certain length of SMF. In the DSB or SSB, the shrinkage in the opening eye expounds that transmitting 60 GHz via 130 km and cannot go farther than that distance with only 2.5 Gb/s.

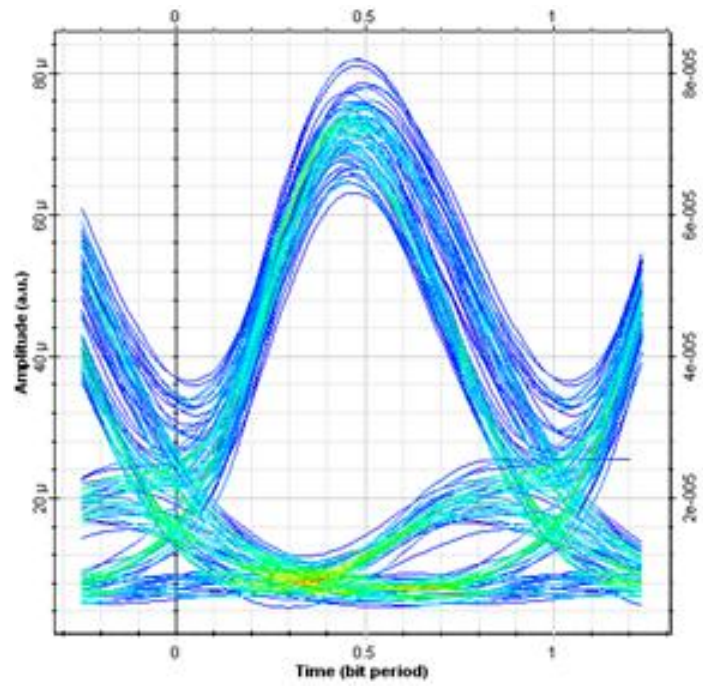

Figure 4.7. Eye diagram of received signal when SSB used at 130 km SMF

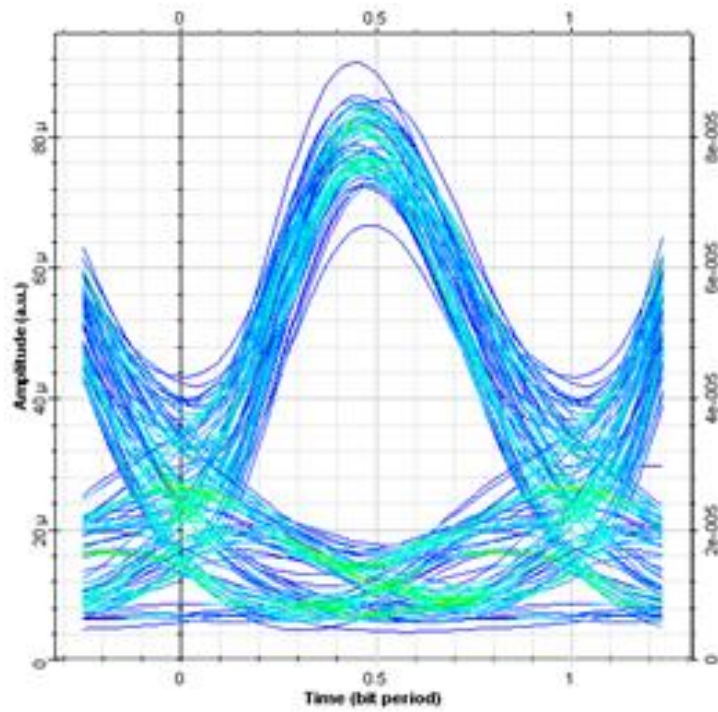

Figure 4.8. Eye diagram of received signal when DSB used at 130 km SMF

Table 4.1 portrays a comparison between two mm-waves modulated by SSB and DSB for different lengths of SMF 30, 80 and 130 km. The comparison between these two methods was for Q-factor values. Despite the high reduction in Q-factor of SSB from 75.33 to 11.3, the value of Q-factor when 130 km SMF is still admitted. The low signal's power of DSB when the 130 km SMF is used would not be enough for receiving a signal with suitable quality. On other hand, the received power when 130 km SMF was used with the SSB method is acceptable.

Table 4.1: Q-factor of SSB and DSB at different SMF length

<b>Length of SMF</b>	<b>Q-factor DSB</b>	<b>Q-factor SSB</b>
<b>30 (km)</b>	16.5	75.33
<b>80 (km)</b>	12.03	22.75
<b>130 (km)</b>	8.87	12.03

## 4.2 Comparison of DSB, SSB and OCS modulation methods in WDM-PON

The integration of any three modulations methods with WDM-PON as in Figure 4.9 could not be satisfied because of the insertion of WDM in the scheme. Each channel of WDM gets an individual wavelength and a 2.5 Gb/s bit rate. As analyzed previously, the SSB method shows enough strength to transmit signals up to 130 km length. However, inserting WDM causes more noise in transmitted signals, and as a result, the quality will drop. On the other hand, DSB could not go further than 80 km. To overcome this issue, an alternative modulation, OCS, as in Figure 3.4, was proposed by [7]. The LO bandwidth in OCS was selected to be 30 GHz with a  $180^\circ$  phase shift. The bias voltage was more than twice the voltage's values at SSB and DSB. Table 4.2 shows a comparison of three modulation methods in Q-factor when they were integrated with WDM-PON. Under different lengths of SMF, the maximum Q-factor occurred when OCS modulation was used. After a certain length of SMF, a dramatic decrease happened because of the dispersion and attenuation in SMF.

Table 4.2: Q-factor of DSB, SSB and OCS at different SMF length

SMF Length (km)	DSB	SSB	OCS
30	18.96	44.55	51.19
70	7.6	10.4	12.37
100	3.8	5.2	7.4

Having a low Q-factor value means that DSB has the maximum value of BER while the minimum value occurred when OCS was used. This increase in BER value in DSB is related to the integration with WDM-PON. Moreover, the DSB modulation method cannot support the RF to travel more than 80 km.

The three eye diagrams of these three methods are portrayed in Figure 4.9, Figure 4.10 and Figure 4.11 and prove that when 80 km SMF was used, the biggest opening eye appeared when OCS was used. The modulated RF signal by OCS has enough strength to carry bit rate smoothly with less BER.

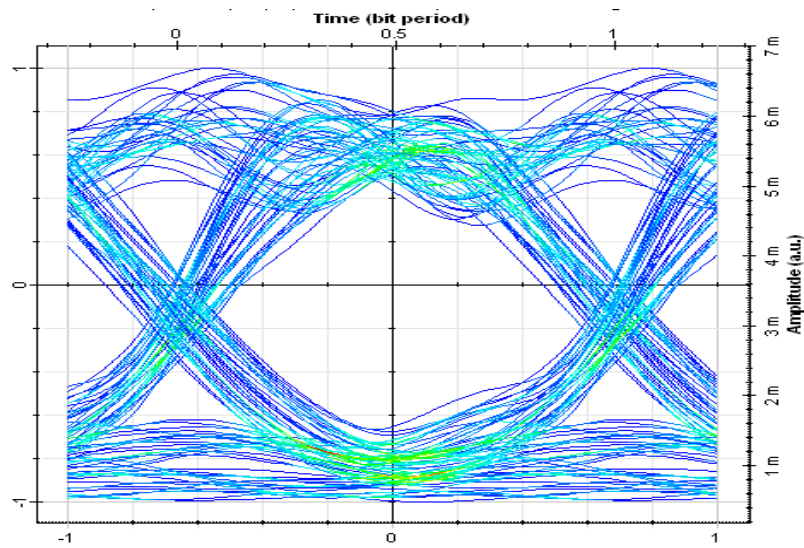

Figure 4.9: Eye diagrams of OCS at WDM-PON 80 km SMF



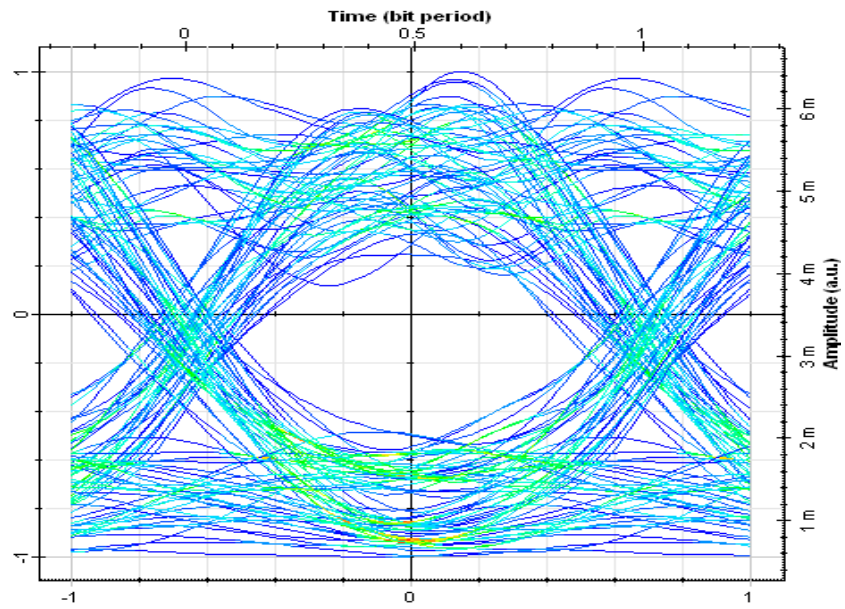

Figure 4.10: Eye diagrams of SSB at WDM-PON 80 km SMF

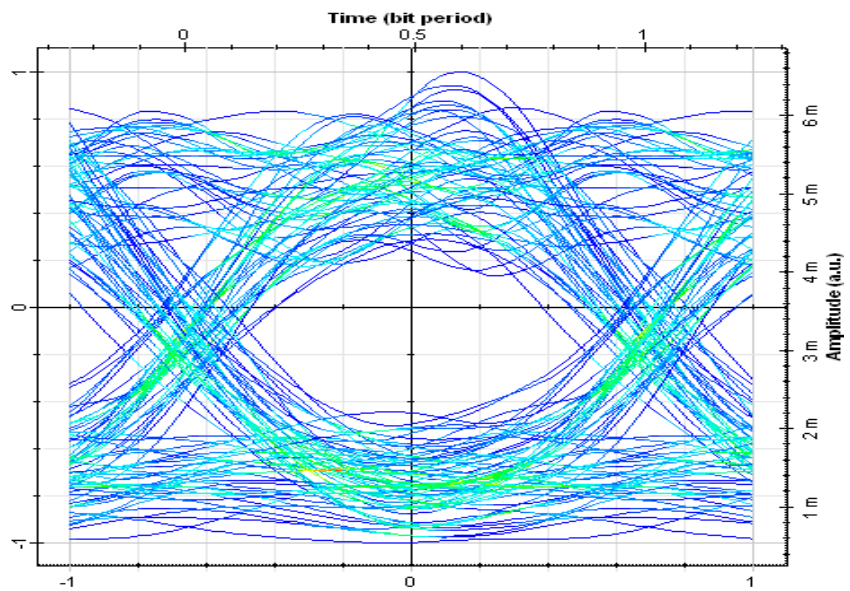

Figure 4.11: Eye diagrams of DSB at WDM-PON 80 km SMF

Having qualified RF signals contributes to transmitting a higher bit rate to the end user. The three modulation methods were tested when the SMF length was equal to 40 km and the bit rate was 10 Gb/s. Table 4.3 compares these three methods in Q-factor, OSNR, received power. The maximum Q-factor appeared when OCS was used, however the minimum Q-factor was when DSB was used. Because of the good quality in the received signals, the OCS modulation method showed to be the best method to transmit 10 Gb/s via the WDM-PON system up to 40 km. From the Eye diagrams of all three methods, it can be clearly seen that the big opening eye appeared when OCS used. The eye diagram is more evidence for OCS being the best method.

Table 4.3: Q-factor, SNR and power of the received signal in WDM-PON

	<b>OCS</b>	<b>SSB</b>	<b>DSB</b>
<b>Q-factor</b>	8.855	6.05	4.23
<b>OSNR</b>	22.3	14.36	29.95
<b>Power</b>	-47.93	-45.7	-29.36

### 4.3 Modulated RF signals by using OFDM format

In this part, the scheme in Figure 3.8 was built in Optiwave software in order to find the OSNR, the received power, and the electrical constellation of the received signal. Two different modulation methods of OFDM were used to discover the best methods among them. The multiplexed signals of four channels were sent over a 40 km SMF with a bit rate equal to 20 Gb/s and 30 Gb/s. The used methods for OFDM modulations were QAM and PSK with different M order such as BPSK, 16-PSK, 16-QAM and 64-QAM. The OFDM output was modulated with RF 20 GHz by MZM. Even though adding an RF signal helped to expand the bandwidth of the carrier signals, it caused a drop in the signal's power. To overcome this issue, the CW input power was increased to maintain the required power of the transmission process. An increase in the CW input power varies from one modulation method to another. For example, the 64-QAM needs less input power than 16-QAM, and BPSK needs the largest increase in CW power. Figure 4.12, Figure 4.13 and Figure 4.14 show optical spectrums of the signals before sending via 40SMF of three different modulation methods.

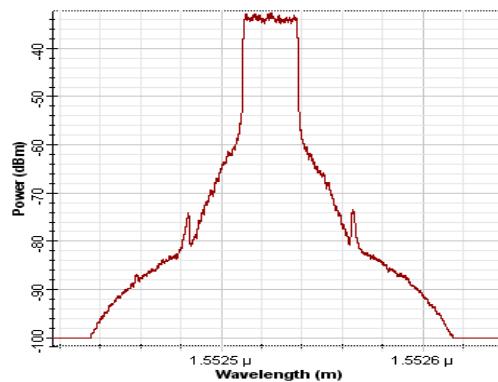

Figure 4.12. Optical spectra for one channel of WDM when 64-QAM use

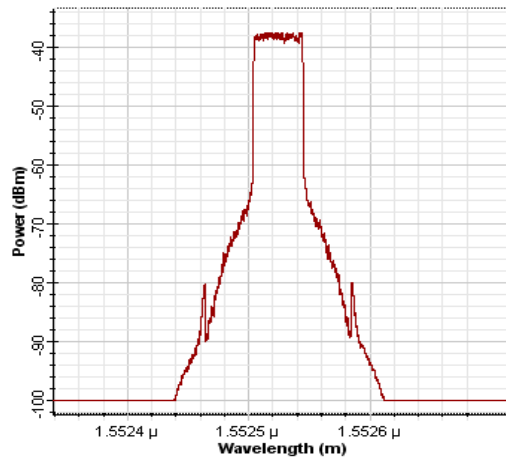

Figure 4.13. Optical spectra for one channel of WDM when 16-QAM used

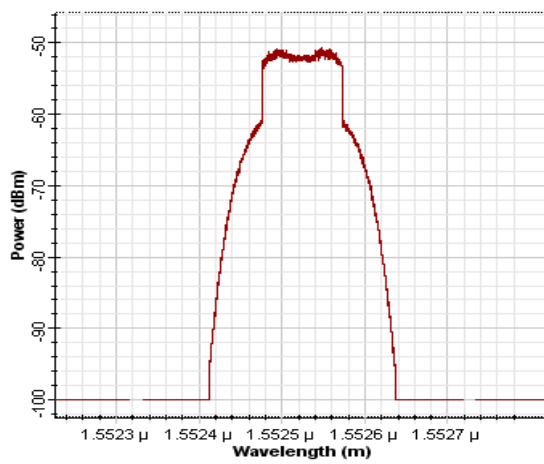

Figure 4.14. Optical spectra for one channel of WDM when BPSK used

### 4.3.1 20 Gb/s OFDM signals over 40-km SMF by using QAM modulation

A useful representation in such a communication system is electrical constellation analyzers, which were used to portray electrical constellation of all used modulation methods before the demodulation process. In this part, the chosen modulated method of OFDM is QAM with two different orders, 16-QAM and 64-QAM. Figure 4.15 and Figure 4.16 show electrical constellation diagrams for 16-QAM and 64-QAM respectively when 20 Gb/s was used with a 40 km length of SMF. It can be clearly seen that 16-QAM has very separated constellation points and there is a large distance between the two points while the most scattered points appeared with 64-QAM.

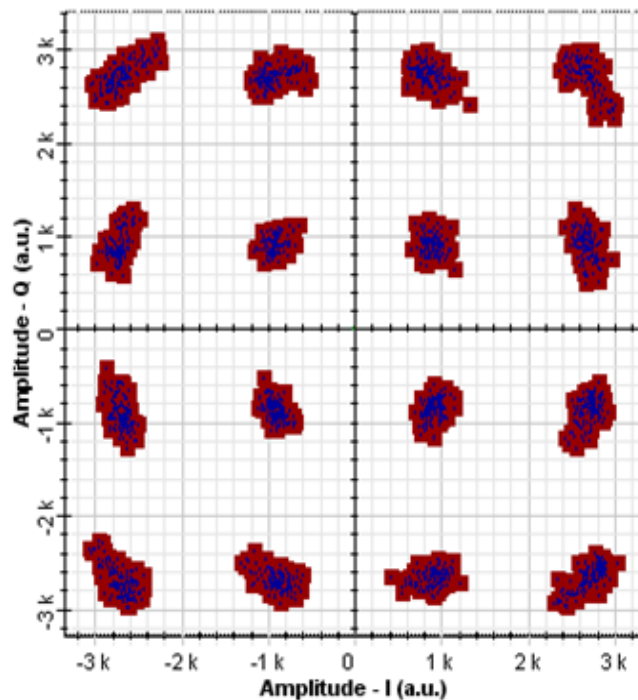

Figure 4.15: Received signal constellation of 16-QAM after 40 km SMF

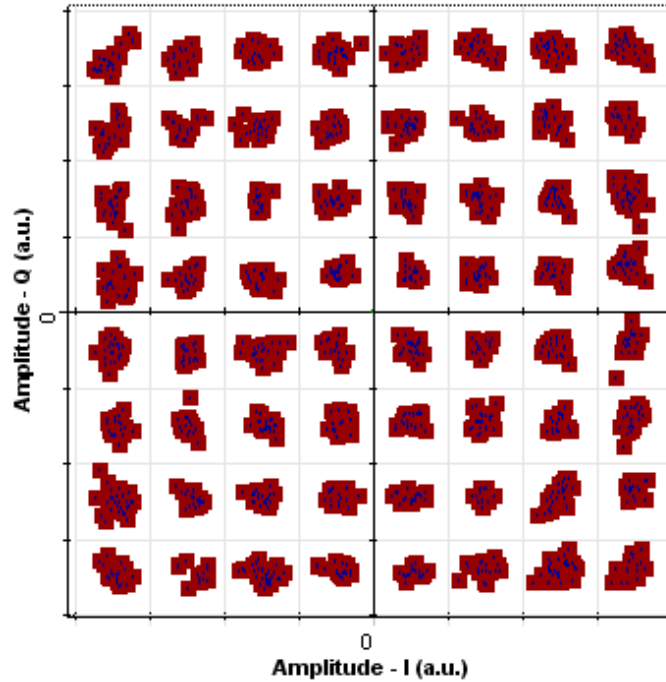

Figure 4.16: Received signal constellation of 64-QAM after 40 km SMF

Table 4.4 contains a comparison of received signals under a different order of the QAM modulation method. It is apparent that using OFDM formatting with the 64-QAM modulation method has the highest value of OSNR and received power. The lowest OSNR and received power occurred when the 16-QAM method was used. Since there is low received power in 16-QAM, it is sufficient for only one bit per symbol. On the other hand, the highest values of OSNR and received power in 64-QAM might not be adequate for six bits per symbol.

Table 4.4 : OSNR and power of the received signal with different modulation methods

SMF length (Km)	OSNR (dB)		Received Power (dBm)	
	16-QAM	64-QAM	16-QAM	64-QAM
40	97.31	97.47	-5.16	-4.52619
80	35.89	41.25	-53.05	-50.6
120	27.9	33.3	-61.02	-58.75

Having a high OSNR value and received power could not be enough to have less BER. Figure 4.17 and Figure 4.18 show an OSNR vs BER when 16-QAM and 64-QAM are used. From these two figures, it is evident that 16-QAM has less BER value than 64-QAM at different values of OSNR. When OSNR values are increased, BER in both methods decreased. However, BER reached lower value at 16-QAM.

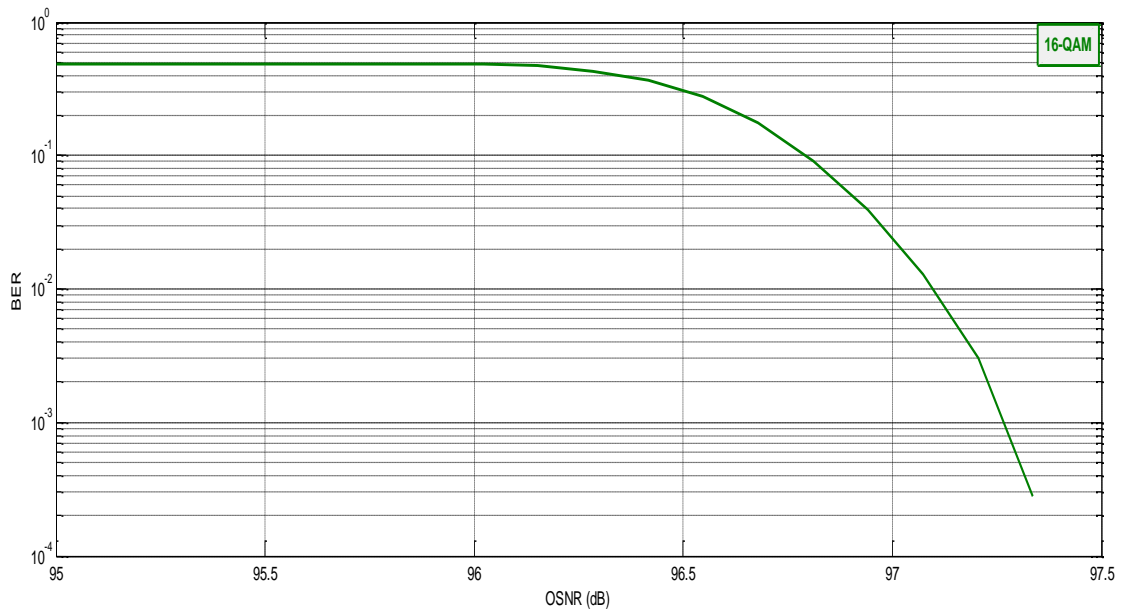

Figure 4.17. OSNR vs BER of 16-QAM after 40 km

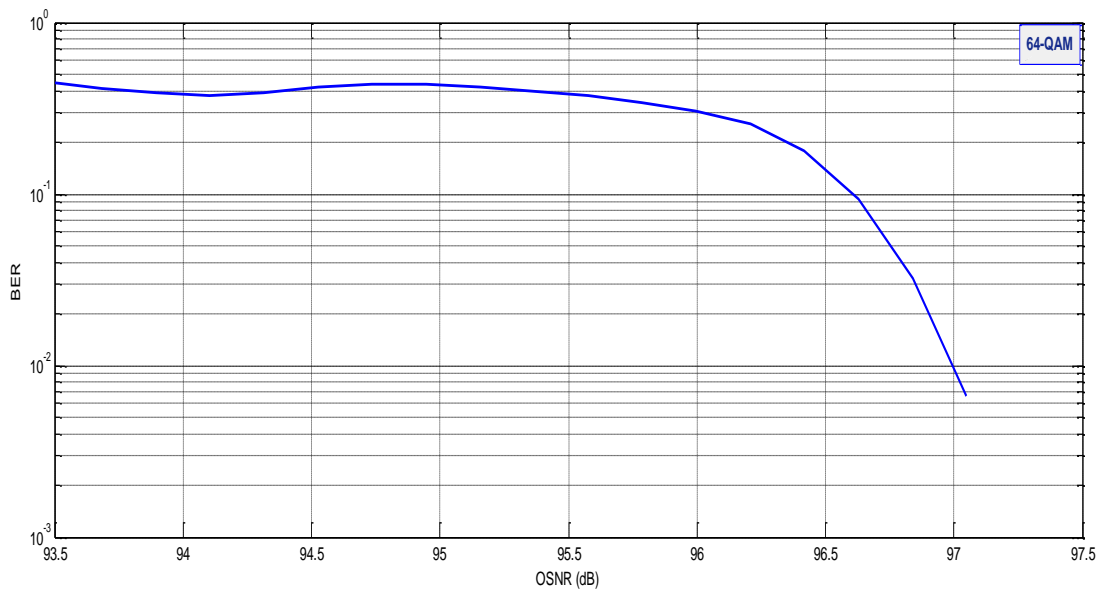

Figure 4.18. OSNR vs BER of 64-QAM after 40 km



### 4.3.2 20 Gb/s OFDM signals over 40-km SMF by using PSK modulation

In this part, two orders of PSK were used as a modulation method of OFDM which are 8-PSK and 16-PSK. As a technique for measuring the BER of the received signals, an electrical constellation was used again in this part. Figure 4.19 and Figure 4.20 show two different constellations of the received signal when 8-PSK and 16-PSK were used. Each point of the 8 points in the 8-PSK constellation represents a 3 symbol. However, it represents a 4 symbol per bit in 16-PSK. Clearly, there is enough space between two points in the constellation diagram when 8-PSK was used, which helps to eliminate the scattering. On the other hand, this space between any two points when 16-PSK was used became smaller. As a result the BER in 16-PSK increased.

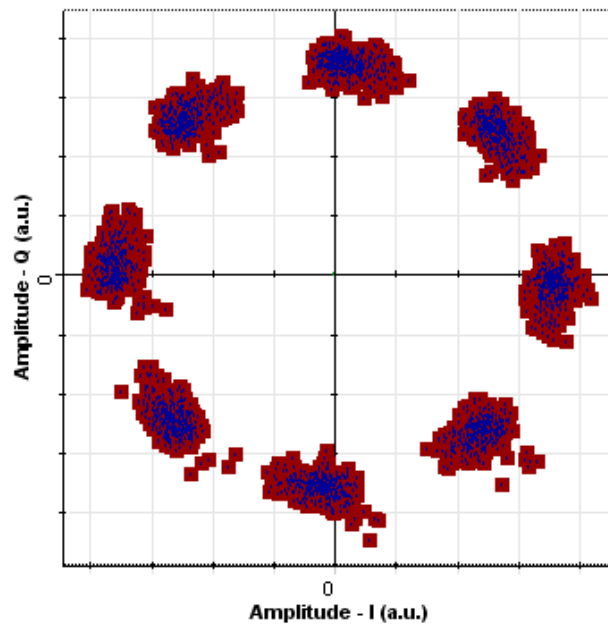

Figure 4.19: Received signal constellation of 8-PSK after 40 km SMF

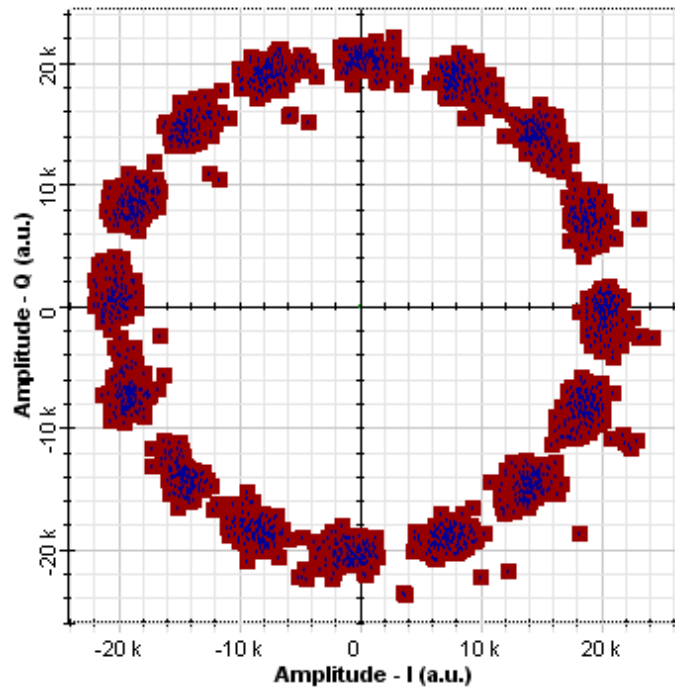

Figure 4.20: Received signal constellation of 16-PSK after 40 km SMF

In another comparison between the two different orders of PSK modulation, table 4.5 shows the values of an OSNR and received power signal. The differences of OSNR and received power values in these two methods were very subtle. Because of having a larger capacity, 16-PSK is preferable when used with almost equal OSNR and received power in both orders. The BER in 16-PSK is larger than BER in 8-PSK according to Figure 4.21. The high BER in 16-PSK is related to the capacity, which is bigger than the capacity offered by 8-PSK.

Table 4.5 : OSNR and the received power with two different order of PSK

	8-PSK	16-PSK
OSNR (dB)	78.7466	78.8159
Received power (dBm)	-21.2534	-21.1841

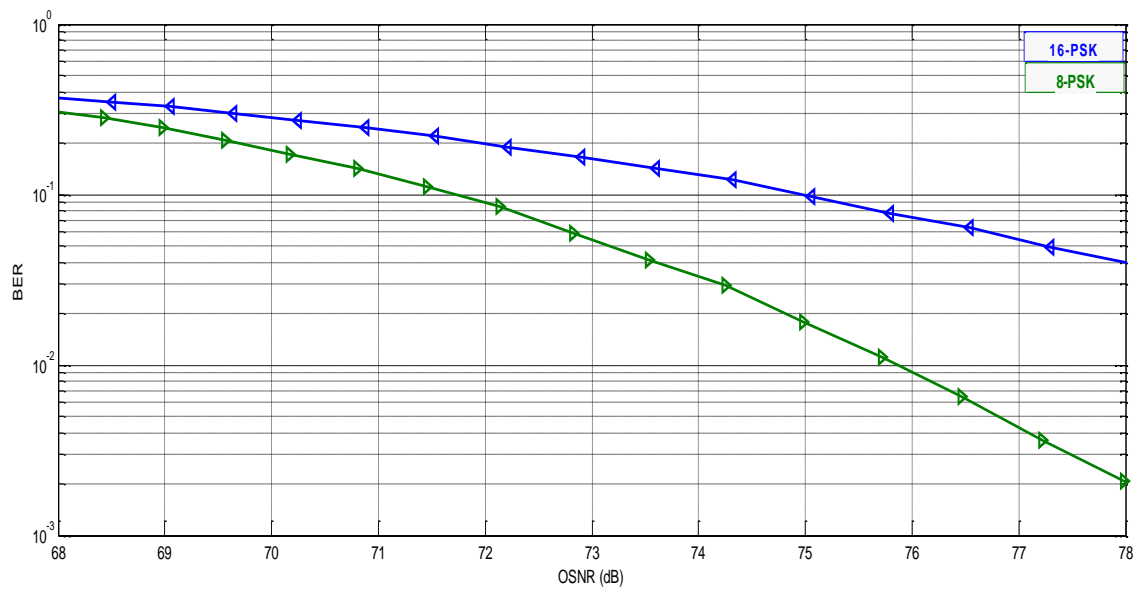

Figure 4.21 OSNR vs BER of the received signal when 8-PSK and 16-PSK used at 20 Gb/s

#### **4.4 Results Evaluation**

For the first part of the results, a comparison was done in terms of BER between two different up-conversion methods of millimeter-wave. The BER in such proposed methods by [7] was successfully demonstrated when they were used in PON system. These implementations, which were achieved when PON was used, allowed an increase in the transmission length up to 130 km and in the bit rate up to 10 Gb/s. For 80 km SMF long, the maximum achieved received power in SSB was around -6.43 dBm after it was around -28 dBm with only a 40 km transmission length. Further, the log BER was improved to be -117 after it was 11. On the other hand, using DSB in PON improved the received power from -20 dBm with only 2 km SMF used to -6.2 dBm with 80 km SMF.

The second part of the results contains a study of three proposed methods by [7] after integrating each one of them in WDM-PON. All three methods were practically proven to be used in WDM-PON up to 70 km SMF length. The maximum Q-factor at different lengths of SMF occurred when an OCS method was used up to 130 km, 10 Gb/s for each channel, and was successfully achieved with OCS. Transmitting 10 Gb/s for each channel of WDM means the WDM-PON can transmit more than 1.6 Tb/s when 160 WDM used.

The last part of the results show the use of an OFDM format modulation to modulate RF signals. In [43], OFDM-WDM-PON was designed by using 2.5 Gb/s 16-QAM then transmitting over 20 km SMF. Many implementations were applied to this design in order to send 20 Gb/s in OFDM-WDM-PON by using two

different modulation formats PSK and QAM with varied orders and transmitted over 40 km SMF. All four modulation methods successfully achieved the required BER for having a qualified signal. Even though the highest BER occurred when 64-QAM was used, it was suitable because of the high capacity of the large number of symbols that 64-QAM offered.

## **Chapter Five**

### **Conclusion and Future wor**

#### **5.1 Conclusion**

The performance of BER was studied and analyzed at different types of RF modulations. In the first part, using more than one up-conversion technique of millimeter-wave was analyzed. The three methods showed a diversity of received signal details which depended on the SMF length and bit rate. Between SSB and DSB in only single RoF, SSB showed a high quality received signal even when SMF length was expanded. On the other hand, the produced signal in DSB showed less ability to be transmitted over long distance than SSB did. Having less ability is related to SMF dispersion which mostly occurs when a double-sided band signal is transmitted. Transmitting a signal with a double-sided band at 60 GHz of LO means that the signal frequency is 120 GHz for both bands. Integrated RF signals with WDM-PON proved that OCS had the Q-factor among all three methods after certain SMF lengths with a bit rate of 10 Gb/s for each signal channel of WDM.

The second part of this thesis was about using the OFDM format to modulate an RF signal. The OFDM multicarrier device is considered one of the advanced modulations that helps to meet the future broadband demand. Two

different modulations of OFDM were used with different order. Among all QAM or PSK orders, the lowest BER occurred when BPSK was used, however, BPSK only transmitted one bit per symbol. Transmitting a high amount of bits per symbol makes 64-QAM and 32-PSK highly recommended modulation methods under low BER assumption. In this thesis even though the largest BER happened when 64-QAM was used, and the BER was still suitable for transmitting a high quality signal with 20 Gb/s.

## 5.2 Future work

One of this thesis' conclusions is that the BER in OFDM modulated by a certain order of QAM or PSK, such as 64-QAM, increases when the order increases. The relationship between the transmitted signals' capacities and the order of the modulation formats QAM or PSK is proportional. In other words, the desirable order of QAM or PSK is higher and better. However, managing and maintaining the orthogonality in OFDM is one of its challenges. The main point of the orthogonality in OFDM is to protect the central frequency of the subcarrier from interfacing.

For my future work, I am considering using an OFDM modulation format with a high order of either QAM or PSK and finding a solution for the interfaces that harm the orthogonality. The modulated OFDM signal

$$\sum_{h=0}^{N-1} S_h e^{j2\pi f_h t} = \sum_{h=0}^{N-1} S_h \varphi_h(t) \quad \text{for} \quad 0 \leq t \leq Ts$$

where

$$f_k = f_0 + h\Delta f$$

and

$$\varphi h(t) = \begin{cases} e^{j2\pi f_h t} & 0 \leq t \leq T_s \\ 0 & \text{otherwise} \end{cases}$$

$T_s$  is the symbol duration and  $\Delta f$  is the subchannel space of OFDM. To keep the orthogonality, these two parameters have to be maintained especially when a high order of QAM or PSK is used. The symbol duration of the received signals has to be long enough in order to be demodulated by the receiver. The orthogonality condition can be derived from the following formula:

$$T_s \cdot \Delta f = 1$$

To have long symbol duration, the bandwidth of the received power has to be high, and that will eliminate the expected overlapping and save the orthogonality.



## References

- [1] Lath, B & Ding, Z .(2010). “Modern Digital and Analog Communication systems”. Oxford
- [2] Bunch, B & Hellemans, A (2004) ”The History of Science and Technology: A Browser's Guide to the Great Discoveries, Inventions, and the People Who Made Them from the Dawn of Time to Today”. Houghton Mifflin, Boston.
- [3] Shannon. C. E (July.1948). “A Mathematical Theory of Communication”. Bell Syst. Tech. J.
- [4] Koonen, T (May 2006) “Fiber to the home/fiber to the premises: what, where, and when?”,Proc. of IEEE, vol. 94, no. 5, pp. 911-934.
- [5] Salvador Asensi Pla, J., (2011) “Design of Passive Optical Network”, Department of Telecommunications, Faculty of Electrical Engineering and Communication Brno University of Technology.
- [6] S. W, S. & L,Y. & Wang, T (2012)“The Comsoc Guide to Passive Optical Networks Enhancing the Last Mile Access”, Canada: IEEE communication society.
- [7] Jia, Z. (August.2008)“Optical millimeter- wave signal generation, transmission and processing for symmetric super-broadband optical-wireless access networks” PhD Dissertation, Electrical Engineering, Georgia Tech.
- [8] Kazovsky, L., Shaw, W., Gutierrez, D., Cheng., N & Wong, S. (Nov.2007) “Next-generation optical access networks," J. Lightw. Technol., vol.25, no.11, pp.3428-3442.
- [9] Bavey, R., Kani, J., Bourgart, F., & McCammon, K. (Oct.2006)”Options for future optical access networks," IEEE Commun. Mag., vol.44, no.10, pp.50-56.
- [10] Lam, C. (2007). ” Passive Optical Networks: Principle and Practice”. Academic Press, pp 20-30.
- [11] Keiser, G. (2006). “FTTX Concepts and Applications”. Wiley, Hoboken, NJ.

- [12] Lin, C. (2006). "Broadband Optical Access Networks and Fiber-to-the- Home: Systems Technologies and Deployment Strategies", Wiley, Hoboken, NJ.
- [13] Kramer, G. (2005). "Ethernet Passive Optical Networks", McGraw-Hill, New York.
- [14] Keiser, G.(2011). "Optical fiber communication" 4<sup>th</sup> ed, McGraw-Hill, New York.
- [15] Presi, M., Proietti, R., Prince, K., Constestabile, G., and Ciaramella, E (2008), "A 80 km reach fully passive WDM-PON based on reflective ONUs," Opt. Express, Vol. 16 pp. 19043-19048.
- [16] Tomlinson, W. J.; Lin, C., (May.1978) "Optical wavelength-division multiplexer for the 1–1.4-micron spectral region", Electronics Letters, vol. 14, p. 345–347.
- [17] Li-Jia, Z., Xiang-Jun, X., Bo, L., Qi, Z., Yong-Jun, W., and Chong-Xiu, Y.(May.2010 ) "Broadband Convergence of 40 GHz-ROF and 10-Gb/s WDM-PON Systems in the Duplex Access Network," Chinese Physics Letters, vol. 27, no. 5, p. 054203.
- [18] ITU-T Recommendation G.694.1, Dense Wavelength Division Multiplexing (DWDM), (June.2002).
- [19] ITU-T Recommendation G.694.2, Coarse Wavelength Division Multiplexing (DWDM), (Dec.2003).
- [20] Keiser, G., E., (Jan.1990). "A review of WDM technology and applications," IEEE J. Select Area Commun, Vol. 5, pp.3-39.
- [21] Banerjee, A., Park, Y., Clark, F., Song, H., Yang, S., Kramer, G., Kim, K., and Mukerjee, B, (Nov.2005). "Wavelength-division-multiplexing passive optical network (WDM-PON) technology for broadband access: a review" ,J. optical Networksing, Vol. 4, no. 11, pp737-756.
- [22] Poboril, R., Latal, J., Koudelka, P., Vitasek, J., Siska, P., Skapa, J., and Vasinek, V (2012)"A Connccept of a Hybrid WDM/TDM Topology using the

Fabry Perot Laser in the Optiwave Simulation Environment”, *Advances in Electrical and Electronic Engineering*, pp. 167–178.

- [23] Ng’oma, A. (June.2005). “Radio-Over-Fiber Technology for Broadband wireless communication systems”, Eindhoven University of Technology, Netherlands.
- [24] Wake, D. (2002). “Radio over fiber systems for mobile applications” in *radio over fiber technologies for mobile communications networks*”, (Al-Raweshidy, H., & Komoaki, S, Eds.). Artech House, Inc, USA.
- [25] Yu, J., Jia, Z., Yi, L., Su, Y., Chang, G.-K , and Wang, T.(Jan.2006). ”Optical millimeter-wave genera-tion or up-conversion using external modulators,” *IEEE Photon. Technol. Lett.*, vol.18, no. 1, pp. 265-267
- [26] Rosa, L., Selleri, S., Tartarini, G., Faccin, P., and Fabbri, E. M. ( Sept.2006). “Distortion performance prediction in multi-band radio over \_ber systems exploiting direct laser modulation,” *36th European Microwave Conference*, pp. 1292-1295.
- [27] Fuster, J. M., Marti, J., Corral, J. L., Polo, V., and Ramos, F. (July.2000). “Generalized study of dispersion-induced power penalty mitigation techniques in millimeter-wave fiber-optic links,” *J. of Lightw. Technol.*, vol. 18, no. 7, pp. 933-940.
- [28] Smith, G. H. Novak, D. Ahmed, Z.(Aug.1997 ) “Overcome chromatic-dispersion effects in fiber-wireless systems incorporating external modulators,” *IEEE Trans. on Microw. Theoryand Tech.*, vol. 45, no. 8, pp. 1410-1415.
- [29] Yu, J., Jia, Z., Yi, L., Su, Y., Chang, G.-K , and Wang, T.(Jan.2006). ”Optical millimeter-wave genera-tion or up-conversion using external modulators,” *IEEE Photon. Technol. Lett.*, vol.18, no. 1, pp. 265-267
- [30] Rajalakshmi, S., Srivastava, A., and Pandey, A. (2012).“RSOA based 10G WDM for long reach PON using Manchester Coding for Re-Modulation”, *International Journal of Engineering Science and Technology*, vol. 4, no. 04, pp. 1767–1775.

- [31] Frigo, N, J., (1997). "A survey of fiber optic in local access architectures", in optical fiber telecommunications, IIIA, pp 461-522
- [32] Afifi, N, S., Othman, M., and Tukiran, Z. (2008). "Optimization for the Best Performance for Wavelength Division Multiplexed Passive Optical Network", Proceedings of EnCon2008" pp. 1038–1043.
- [33] Zhang, J., and Ansari, N (Jan.2010) "Design of WDM PON With Tunable Lasers: The Upstream Scenario", J. Lightw. Technol, Vol. 28, No. 2.
- [34] Alateeq, A., Alatawi, K., Almasoudi, F., and Matin, M, A., (November.2012) "Design of Broadband RoF PON for the Last Mile" Scientific and research: Journal of communications and network, Vol. 4, pp 269-277.
- [35] LaSorte, N., Justin Barnes, W., and Refai, H (2008). "The History of Orthogonal Frequency Division Multiplexing", Global Telecommunications Conference, 2008. IEEE GLOBECOM 2008. IEEE, pp 1-5
- [36] Stephen B, W. (June.2009) "The history of orthogonal frequency-division multiplexing [History of Communications]", Communication magazine IEEE, Vol. 47, No. 11, pp 26-35.
- [37] Albdran, S., Alshammari, A., & Matin, M. (2012). "The Sensitivity of Bit Error Rate (BER) Performance in Multi-Carrier (OFDM) and Single-Carrier", SPIE optics and photonics.
- [38] Hanzo, L. Ng, S.X. Keller, T. and Webb, W.T. (2004). "Quadrature Amplitude Modulation: From Basics to Adaptive Trellis-Coded, Turbo-Equalised and Space-Time Coded OFDM, CDMA and MC-CDMA Systems", 2<sup>nd</sup> ed, Wiley, John & Sons, Incorporated ch. 3, sec. 15-17, pp 397-480
- [39] Nowshin, N. Arifuzzman, A. and Tarique, M. (January.2012). "Demonstration and performance analysis of RoF based OFDM-PON system for next-generation fiber optic communication," International J of computer networks & communicationns, Vol. 4, no. 1, pp 193-209.
- [40] Chow, C. Yeh, C. Wang, C. Shih, F. Pan, C. and Chi, S.(July.2008). "WDM extended reach passive optical networks using OFDM-QAM," Optics express, Vol. 16, No. 16, pp 12096-12101.

- [41] Hu, X. Zhang, L. Cao, P. Wang, K. and Su, Y.(March.2012)“ Energy-efficient WDM-OFDM-PON employing shared OFDM modulation modules in optical line terminal,” optics express, Vol. 20, No. 7, pp. 8071-8077.
- [42] Huang, J. Liu, D. and Zeng, C.( March.2011)“ 10 Gb/s WDM-PON using downstream OFDM and upstream OOK,” computer and information science, Vol. 4, No. 2, pp 34-38.
- [43] Hu, M. Wu, S. Fang, M. and Tang, L.(2011). “A wavelength reuse OFDM-WDM-PON architecture with downstream OFDM and upstream OOK modulations,” ICCSN, 2011 3<sup>rd</sup> international conference on, pp 389 – 392.

## **List of Publications Journal**

1. Alateeq A. and Matin, M. A., "Using M-QAM-OFDM in Downstream Link and WBTW-SOA in Upstream of a Bidirectional WDM-PON System", Optics and Photonics Journal, Vol. 3, pp 88-92, 2013
2. Alateeq A. and Matin, M. A., "Study of the BER performance in RoF-OFDM system modulated by QAM and PSK", IOSR Journal of Engineering, Vol. 3, No.2, pp 27-32, 2013.
3. Alateeq A., Alatawi K., Almasoudi F, and Matin, M. A., "Design of Broadband -PON for the Last Mile", Communications and Network, Vol. 4, No. 4, pp 269-277, 2012.

## Appendix A: Journal Publications

*Optics and Photonics Journal*, 2013, 3, 88-92

doi:10.4236/opj.2013.31014 Published Online March 2013 (<http://www.scirp.org/journal/opj>)



# Using M-QAM-OFDM in Downstream Link and WBTW-SOA in Upstream of a Bidirectional WDM-PON System

**Ayoob Alateeq, Mohammad A. Matin**

Department Electrical and computer Engineering, University of Denver, Denver, USA

Email: Ayoob.alateeq@du.edu

Received January 18, 2013; revised February 20, 2013; accepted February 27, 2013

### ABSTRACT

The passive optical network WDM-PON is one of the most dominant performers of all communication systems, and provides sufficient broadband service. Providing enough data for the demands of today and the future, marks this area as a critical topic for researchers. The first goal of this article is to study the performance of OFDM in a bidirectional WDM-PON by using QAM and BPSK modulation methods in the downstream link. The second goal is to build the upstream link with WBTW-SOA and show its ability to transmit the upstream signal with low equipment. Sending and receiving signals from the central office to the last mile, and opposite of the network up to 100 Km via a bidirectional single mode optical fiber (SMF) was successfully achieved.

**Keywords:** PON-WDM; OFDM; QAM; BPSK

### 1. Introduction

Provisioning broadband services for downloading and uploading high definition data has become a difficult requirement for data providers. Covering users' data demand for the future has encouraged many researchers to find suitable ways to develop transmitted or received data. Using a wavelength division multiplexing in passive optical

network (WDM-PON) is one of the implementations that have been added to cover this additional demand **Figure 1**. WDM-PON has shown its ability to increase the bandwidth of the signal, as a result of expanding the bandwidth, the signal capacity will increase [1]. Moreover, transmission data via optical fiber has a limitation of how far distance data can be transmitted, after a certain

distance dispersion will occur. Besides using WDM-PON in the communication systems as an enhanced change, orthogonal frequency division multiplexing (OFDM) has been used to encode data in a multicarrier frequency. The carrier signal of an OFDM is the sum of the orthogonal subcarriers, which are individually modulated by different types of modulation such as quadrature amplitude modulation (QAM) or phase-shift keying (PSK). Using M-QAM OFDM in the WDM-PON systems helps to increase multi-accesses of multi-users [2,3]. An easy way to provide multi-paths, which are used in most broadband systems between transmitters and receivers, is to use OFDM. In order for WDM-PON

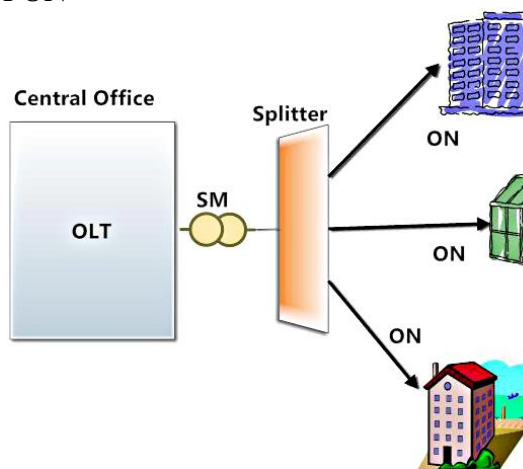

Figure 1. Simple architecture of PON WDM.

to provide multi-paths between the transmission and reception terminals, M-QAM OFDM must be used. Using QAM, which offers orthogonal modulation, helps to modulate each subcarrier independently [4]. In this paper, we have proposed an OFDM bidirectional WDM-PON design that is modulated by several types of QAM for the downstream, and uses a wideband traveling wave semiconductor optical amplifier

WBTW-SOA for the upstream. We have compared several types of OFDM modulations such as BPSK, 16-QAM, and 64-QAM for the same WDM-PON system. We also tried to expand the transmission length up to 100 Km and study the constellation and SNR of downstream and BER and Q factor of upstream.

## 2. Design Configuration

### 2.1. Downstream Design

Figure 2 contains four identical channels that are multiplexed by a wavelength division multiplexer. For the downlink design, in each channels OFDM is used. Modulation of OFDM in this design has been tried by using BPSK 16-QAM and 64-QAM. Each one of the two ports of OFDM goes through low pass filter LP which has a cutoff frequency equaling 7.44 GHz. The filtered signals will be modulated with CW lasers by using mach zehnder modulators (MZM). The output laser signals of MZM will be multiplexed by using WDM and sent via bidirectional single mode optical fiber (SMF). The optical fiber length in this design has been varied from 40 to 100 Km. Before and after the optical fiber, multiplexed signal in the downlink will pass through two EDFAs with gains equal to 13 dB and 12 dB respectively. After the second EDFA an optical circulator is used to redirect the signals of downlink and uplink. At the receiver side, and after the circulator, DWDM is used to separate the received signal into four signals for each channel. Each signal has been detected by a photodiode detector, which converts the optical signal to an electro signal. This electrical signal will be demodulated by using an OFDM demodulator and a QAM



sequence decoder [1-3,5-10].

## 2.2. Upload Design

For the uplink, the wideband travelling wave semiconductor optical amplifier (WBTW-SOA) is used to simulate the traveling wave SOA that is based on an identical hidden edge SOA. A transmitter source Tx and CW laser source are coupled by using an optical coupler and the output is applied to WBTW-SOA. The output signal of WBTW-SOA will be sent via the uplink of SMF. Before reaching the PD at the receiver side, EDFA is used to amplify the signal. SMF in this link has been varied, and the bit error is compared.

## 3. Result and Discussion

We simulate the design by using the Optiwave software V-11 to analyze and discuss the results. For the downstream link, we tried three different types of OFDM modulation; we used BPSK, 16 QAM, and 64-QAM. For each type, the SMF length varied from 60, 80 and 100 Km. At a certain

length of SMF, we found that maximum received power occurs when 64-QAM OFDM is used. However, the minimum received power occurs when BPSK is used as shown in **Figure 3**. To study the quality of the received signals, which is modulated and demodulated by using QAM, an electrical constellation visualizer is used. Modulation of the digital OFDM signal by using 2-QAM or BPSK was our first step in this experiment. **Figure 4** shows a constellation diagram of three different cases of BPSK, when SMF equals 60, 80 and 100 Km, respectively. A 60 Km length of SMF can be clearly seen, the constellation is more clearly arranged, and the stars are separated (**Figure 4(a)**). Expanding the SMF length up to 80 and 100 Km (**Figures 4(b)** and **(c)**) respectively, gives us constellations that are less arranged than the constellation at 60 km. Having scattered constellations in 80 and 100 km shows that the qualities of the received signals are less than at 60 km, however, these qualities are acceptable overall.

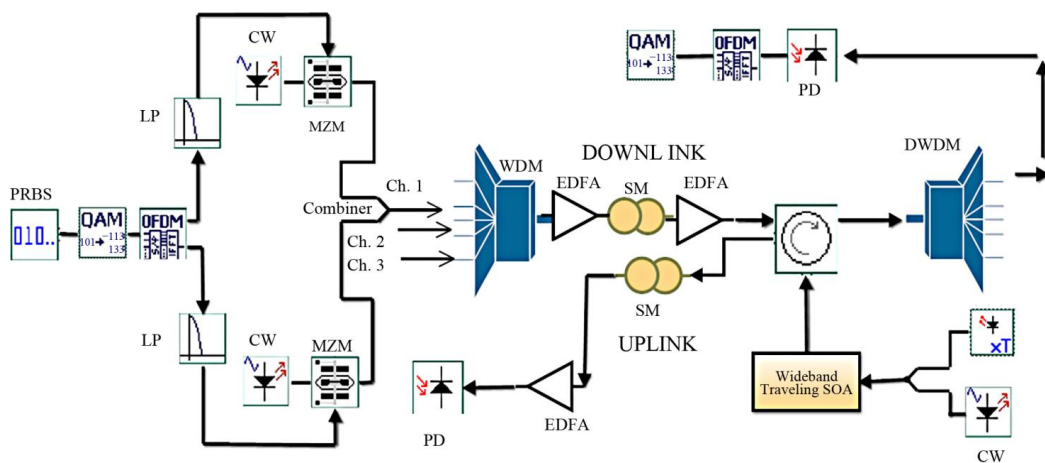

**Figure 2.** Proposed bidirectional WDM-PON system with OFDM downstream link and WBTW-RS for Upstream link.

**Figure 5** represents a constellation diagram where a 16-QAM modulation

is used at a different length of SM. When a 60 km SMF is used, the

received signals show a more clearly arranged constellation (**Figure 5(a)**), as compared to the constellations when 80 and 100 km SMF is used. Using a 64-QAM modulation type produces more power than the other types. However, the constellations of the received signals are more scattered, especially at 100 km (**Figure 6**). The upstream link BER and Q factor were measured at

different lengths of SMF. When 60 Km SMF is used, the BER equals 37.8, and the Q factor is very close to zero. Having less BER and more Q factor portrays a large eye opening in the eye diagram pattern (**Figure 7(a)**). As the SMF length expanded, the BER increases, and the Q factor reduces; as a result the opening eye will become smaller (**Figures 7(b)** and **(c)**).

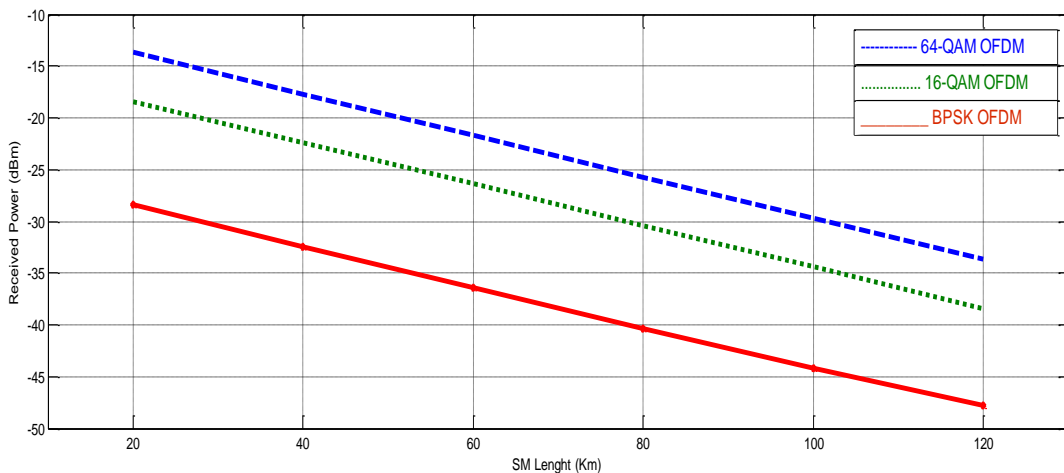

**Figure 3. Received power of downlink signal vs length of SMF.**

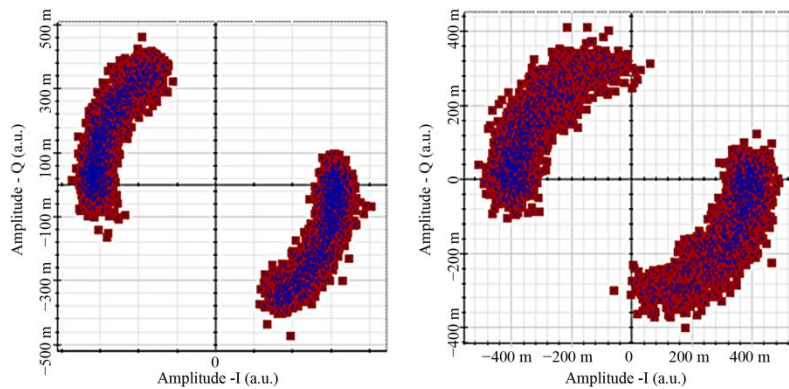

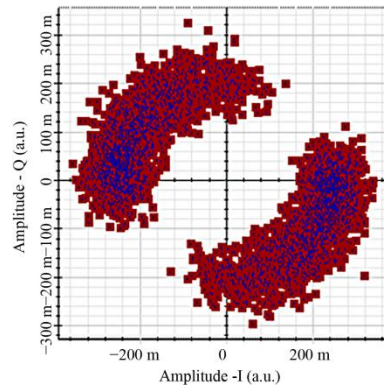

(a) (b) (c)

**Figure 4. Electrical constellation of the received downlink signal modulated by BPSK over (a) 60 Km (b) 80 Km (c) 100 Km.**

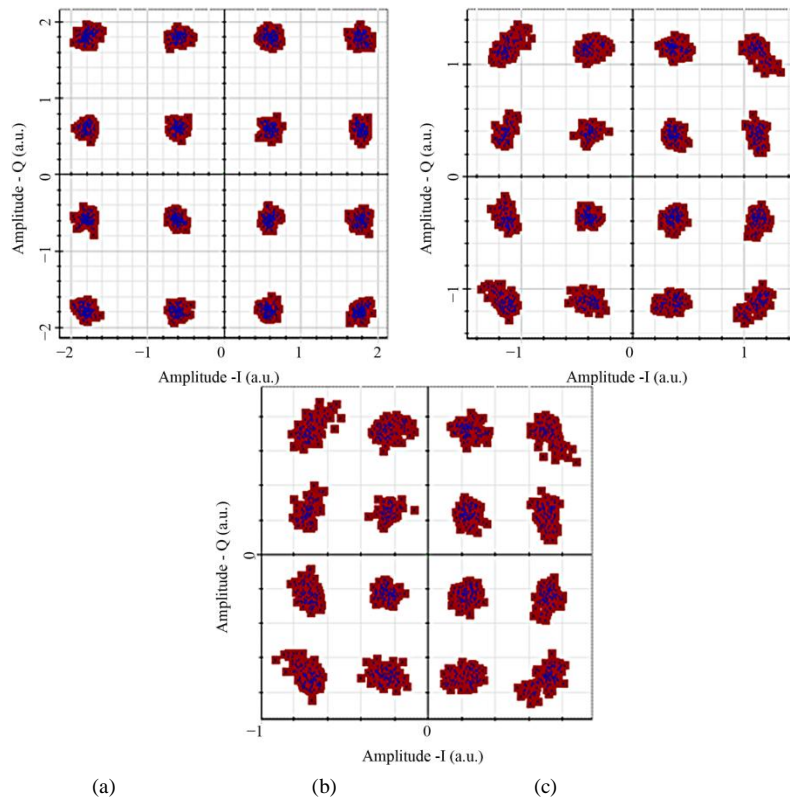

(a) (b) (c)

**Figure 5. Electrical constellation of the received downlink signal modulated by 16 QAM over (a) 60 Km (b) 80 Km (c) 100 Km.**

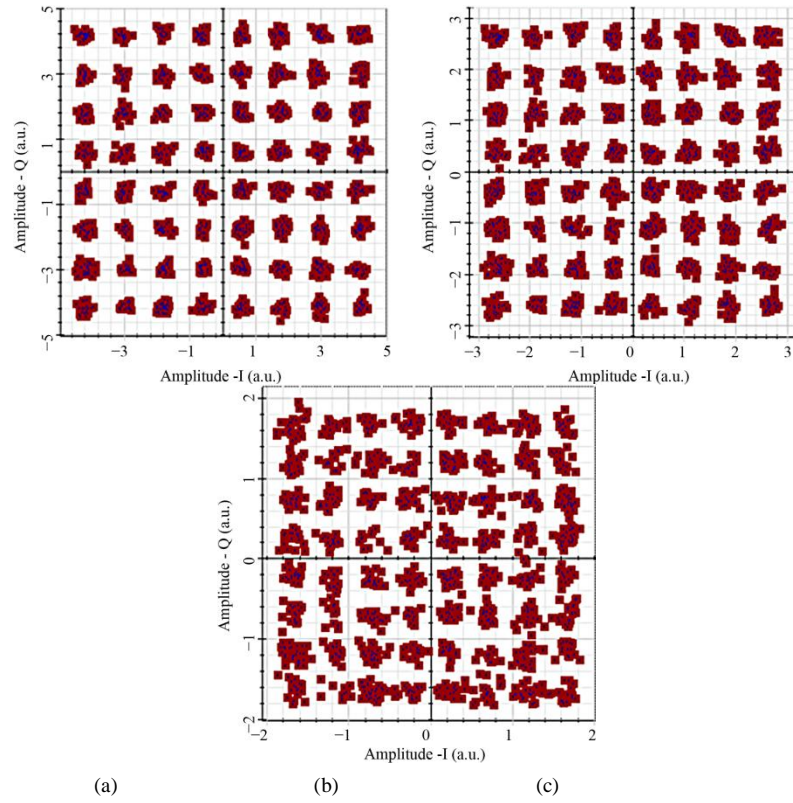

**Figure 6. Electrical constellation of the received downlink signal modulated by 64 QAM over (a) 60 Km (b) 80 Km (c) 100 Km.**

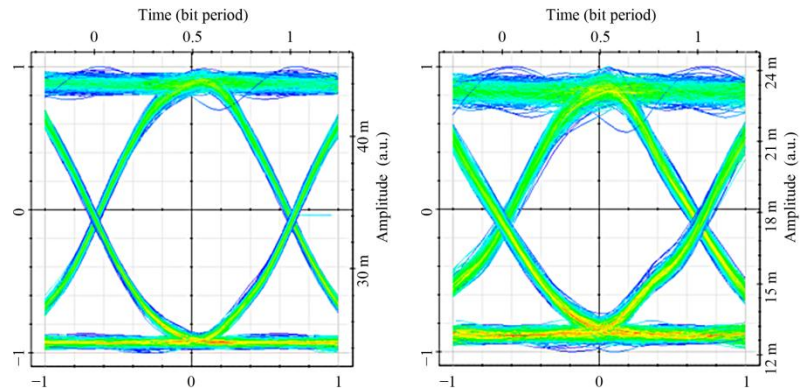

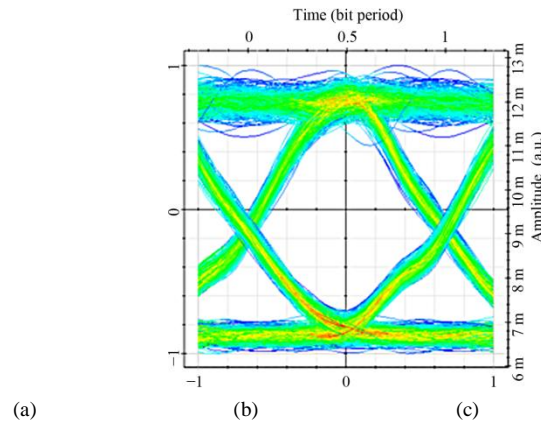

Figure 7. Eye diagram of the received uplink signal with different length of SMF (a) 60 km (b) 80 Km (c) 100 Km.

#### 4. Conclusion

In this paper we have demonstrated how to transmit signals via SMF with lengths up to 100 km by using OFDM, which is modulated by BPSK, 16QAM, and 64QAM in the downstream link. The received signals were studied by using an electrical constellation visualizer, which helps to show the constellation of the symbols at the receiver's end. According to the maximum received power when 64-QAM was used, the best modulation method is 64-QAM, while BPSK is the worst. For the upstream link, the wide band traveling wave modulator was used, and the BER and Q factor of the received signals were measured. Even when expanding the SMF length up to 100 km, the opening eye of the received signals is big enough for having received signals with good qualities.

#### REFERENCES

- [1] S. Chi, C. Yeh and C. Chow, "Broadband Access Technology for Passive Optical Network," *Broadband Access Communication Technology III*, Vol. 7234, 2009, Article ID: 723408.
- [2] M. Hu, S. Wu, M. Fang and L. Tang, "A Wavelength Reuse OFDM-WDM-PON Architecture with Downstream OFDM and Upstream OOK Modulations," *IEEE 3rd International Conference on Communication Software and Networks (ICCSN)*, Xi'an, 27-29 May 2011, pp. 389-392.
- [3] A. Alateeq, K. Alatawi, F. Almasoudi and M. A. Matin, "Design of Broadband RoF PON for the Last Mile," *Scientific and Research: Journal of Communications and Network*, Vol. 4, 2012, pp. 269-277.
- [4] L. Hanzo, S. X. Ng, T. Keller and W. T. Webb, "Quadrature Amplitude Modulation: From Basics to Adaptive Trellis-Coded, Turbo-Equalised and Space-Time Coded OFDM, CDMA and MC-CDMA Systems," 2nd Edition, Wiley, John & Sons, Incorporated, Hoboken, 2004, pp. 397-480
- [5] N. Nowshin, A. Arifuzzman and M. Tarique, "Demonstration and Performance Analysis of RoF Based OFDM- PON System for Next-Generation Faber Optic Communication," *International Journal of Computer Networks & Communications*, Vol. 4, No. 1, 2012, pp. 193-209.
- [6] B. Liu, L. Zhang, X. Xin and J. Yu, "Constellation-Masked Secure Communication Technique for OFDM- PON," *Optics Express*, Vol. 20, No. 22, 2012, pp. 25161- 25168.
- [7] C. Chow, C. Yeh, C. Wang, F. Shih, C. Pan and S. Chi, "WDM Extended Reach Passive Optical Networks Using OFDM-QAM," *Optics Express*, Vol. 16, No. 16, 2008, pp. 12096-12101. [doi:10.1364/OE.16.012096](https://doi.org/10.1364/OE.16.012096)
- [8] X. Hu, L. Zhang, P. Cao, K. Wang and Y. Su, "Energy-Efficient WDM-OFDM-PON Employing Shared OFDM Modulation Modules in Optical Line Terminal," *Optics Express*, Vol. 20, No. 7, 2012, pp. 8071-8077.
- [9] J. Huang, D. Liu and C. Zeng, "10 Gb/s WDM-PON Using Downstream OFDM and Upstream OOK," *Computer and Information Science*, Vol. 4, No. 2, 2011, pp. 34-38.

- [10] B. liu, L. Zhang, X. Xin and J. Yu, "Symmetric Terabit WDM Pre-DFT OFDM Access Network Using PCF- Supercontinuum," *Optics Express*, Vol. 20, No. 22, 2012, pp. 24356-24363.

## **Study of the BER performance in RoF-OFDM system modulated by QAM and PSK**

Ayoob Alateeq, Mohammad Matin

---

**Abstract:** Orthogonal frequency division multiplexing (OFDM) is considered as a one of essential components in most of recent telecommunication systems. To maintain a high bit rate and provide a high bandwidth, using the OFDM as a modulation format in RoF system is preferred over another modulation formats. In this paper, up-converting a 20 Gb/s and a 30 Gb/s OFDM signals on a 20-GHz microwave carrier over 40 km SMF was applied under a different modulation methods of OFDM such as QAM and PSK in order to study the BER performance in all proposal cases.

**Key Words:** *Rof-Of dm, Qam, Psk, Ber*

---

### **I. INTRODUCTION:**

An increase in the broadband demands has induced many studies and researchers to discover urgent and temporary solutions that help to meet the present and future demand. This high requirement in the broadband usage is related to the diversity of the traded signals among customers. After it was limited for only sending and receiving emails, the usage of broadband has extended to be a remarkable need in humans' lives for trading data, voices, and videos signals. Besides this diversity in the use of broadband, broadband mobility shares to be another cause of this shortage. Now days by their smart phones, people checking their emails, skype with each other, and access to downloading or uploading data [1]. As a one solution, RoF-based optical-wireless access is rated. The Rof technology helps to increase the converge, bandwidth, and mobility. The most challenge in the RoF system, as well in any traditional communication system, is to transmit and receive signals with low bit error rate (BER). The modulation and demodulation methods of the transmitted signals in the RoF systems play a role for maintaining the BER. Picking a modulation method for any RoF systems depends on the capacity and the coverage that system works to accomplish [2][3].

Orthogonal frequency division multiplexing (OFDM) is considered to be a promising modulation method for future optical wireless system. The amazing role of OFDM in encoding digital signals in multiple carrier frequencies makes it an appropriate modulation format in such an optical wireless system. Moreover, under bad conditions with high bit rate OFDM proves its ability to be an efficient format in this case. Because of having multiple carrier frequencies, OFDM needs specific modulation methods such as phase shift keying (PSK) or qudrature amplitude modulation (QAM). The PSK and QAM orders, such as 8-PSK and 16-QAM, have different impacts and drawbacks depending on how many bits per symbol need to be transmitted. The transmission and reception stages in the RoF system are not only the effects of increasing BER; however, the optical link between these two stages is another negative effect. To overcome this effect, passive optical networks (PON)s are recommended to use. The PON's impacts are immunization against electro and magnetic interface and low power consumption. Interaction RF signal, that modulated by OFDM format, in a WDM-PON system has shown its ability to maintain the BER. Studying the BER at different modulation methods of RoF-OFDM is the main goal of this paper [1][4][5].



## II. OFDM MODULATION

Inserting OFDM in transmission and reception terminals of any communication schemes needs a specific modulation and demodulation process for transmitted signals. There are several appropriate modulation methods of OFDM; however, the most common methods are QAM and PSK. The requisite process of modulation and demodulation OFDM goes through is shown in the block diagram Figure 1. As in any communication system, block diagram represents the transmission and the receiving terminal. The transmission side process begins by mapping technique by using either PSK or QAM before serial to parallel conversion. The streaming signals pass into IFFT operation before they are protected from overlapping of their information by adding cyclic prefix. The signal reconvert from parallel to series as preparing to send it through wireless channel. At the receiver side starts by a conversion from series to parallel in order to remove the cyclic prefix before goes through FFT. The reception process ends with de-mapping either by using QAM or PSK after parallel to series conversion [6].

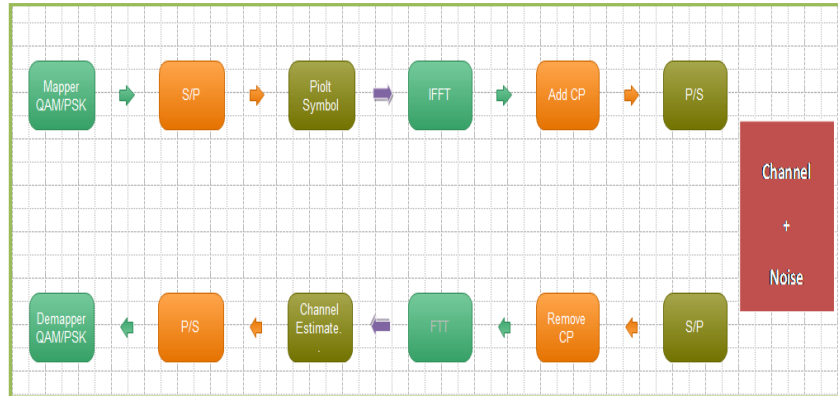

Figure 1: a block diagram of modulation and demodulation process in the OFDM

## III. DESIGN CONFIGURATION

To study and analyze the BER performance in RoF-PON scheme based on OFDM modulation format we built our proposal design in Optiwave V.11. Two of most common methods were used in OFDM modulations which are QAM and PSK. Different types of QAM and PSK such as 16-QAM, 8-PSK, and 16-PSK were tried and compared to learn the performance of BER. Figure 2 shows a block diagram of one channel of our proposal design which contains four identical channels. In each single channel the transmitter side starts with pseudorandom binary sequence (PRBS) with supplies a 20 Gb/s bit rate. The PRBS supplies a string of bit to OFDM modulation throughout either QAM or PSK modulation format with different orders. To change either QAM or PSK order, which is a power of 2, a symbol per bit value has to be changed in order to give the desired order. The OFDM modulator has two electrical output ports each one of them was connected to Mach-Zehnder modulator (MZM) via a low pass filter (LP). Two continuous wave laser diodes (CW) were connected to the optical inputs of MZM-1 and MZM-2. The two outputs of MZM-1 and MZM-2 were combined by using an optical power combiner. The added signal was inserted again to MZM-3, in order to be modulated with 20 GHz local oscillator (LO). Because of having for identical channels wavelength division multiplexing was used in order to send all these channels via one single mode fiber (SMF). The SMF length was chosen to be 40 km, whose chromatic dispersion and attenuation is 16 ps/nm/km and 0.2dB/km respectively. The receiving process begins with WDM demultiplexer which works to separate and distribute each channel. The separated signal reconverted from optical to electrical by using photo diode detector (PD) before it connects to OFDM demodulator [7-11].



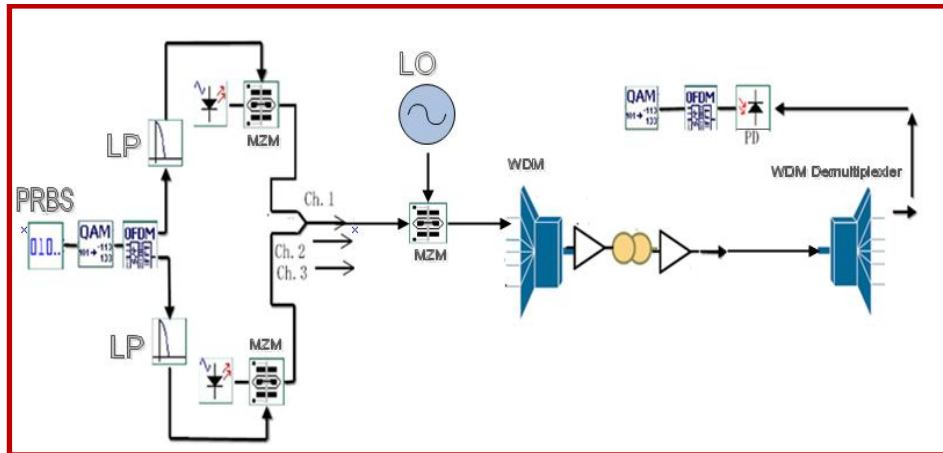

Figure 2. block diagram for a single channel of RoF-OFDM proposal system.

#### IV. RESULTS AND DISCUSSION

By using Optwave V.11, we built the proposal design in order to study the BER of the received signals at different parameters. Two different cases of the system were studied by using different OFDM modulation methods which are 8-PSK, 16-PSK and 16-QAM. The first case was to up-converted 20 Gb/s OFDM signals on a 20-GHz microwave carrier over 40-km SMF. The second case was up-converted 30 Gb/s OFDM on a 20-GHz microwave carrier over 40-km SMF.

#### V. 20 GB/S OFDM SIGNALS OVER 40-KM SMF

PRBS supplied 20 Gb/s to OFDM throughout PSK coder with 3 symbol per bit (8-PSK). Figure 3-a shows an electrical constellation of the received signal after 40-km SMF. It is clearly can be seen each point in the constellation diagram, which contains 3 bits, has enough space without any scattering. Having separated points in the constellation diagram represents a high quality of a received signal. As a one change was applied to PSK coder and decoder, the symbol per bit value was increased from 3 to 4 in order to get 16-PSK and left the other parameters as they were. The constellation diagram of the received signal when 16-PSK modulation technique used is portrayed in Figure 3-b. To find a comparison between using PSK and QAM modulation techniques of RoF-OFDM, we replaced the PSK coder and decoder to 16-QAM. Figure 3-c shows a high quality of received RoF-OFDM by using 16-QAM.

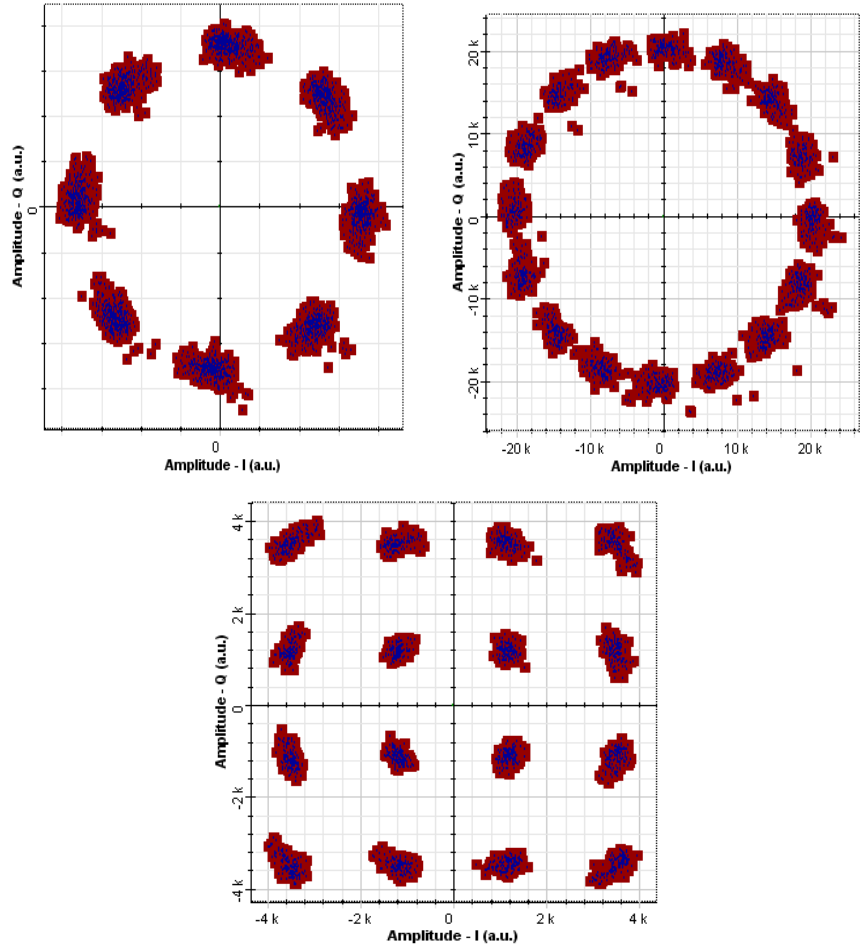

Figure 3. Constellation diagram of the received signal at different modulation of OFDM a) 8-PSK b) 16-PSK c) 16-QAM at 20 Gb/s up-converted

Table 1 has a comparison among the three modulation methods based on the received power, OSNR. The highest OSNR was occurred when 16-QAM used, however the minimum was at 8-PSK. The 16-QAM and 16-PSK have the same capacity; however, in the received power and the OSNR value 16-QAM has the highest value. The reason why 16-QAM is preferred to be used rather than 16-PSK is when the bandwidth is premium while the 16-PSK is preferred to be used when the received power is premium. The received power and OSNR of 8-PSK and 16-PSK were almost the same that means 16-PSK is preferable in case of having a high capacity.

Table 1: OSNR and received power of the received signal at different modulation formats at 20 Gb/s

	8-PSK	16-PSK	16-QAM
<b>OSNR dB</b>	78.7466	78.8159	97.3369
<b>Received power (dBm)</b>	21.2534	21.1841	2.66307

Figure 4 shows a comparison between 8-PSK and 16-PSK in BER vs OSNR. The 16-PSK has a higher BER than 8-PSK. The reason is why BER is higher in 16-PSK than 8-PSK is related to the capacity which is bigger in 16-PSK than 8-PSK. Another reason is related to the orthogonality which is affected by the overlapping in subcarriers. Having a high order of PSK means having a high number of subcarriers which causes overlapping and affect the orthogonality as a result the BER goes higher. The other evident shows the BER is higher in 16-PSK is in Figure 5 which represents a plot of the received power vs log of BER. The log of BER of 8-PSK is higher than 16-PSK which leads to have a low BER if both 8-PSK and 16-PSK have almost the same values of received power.

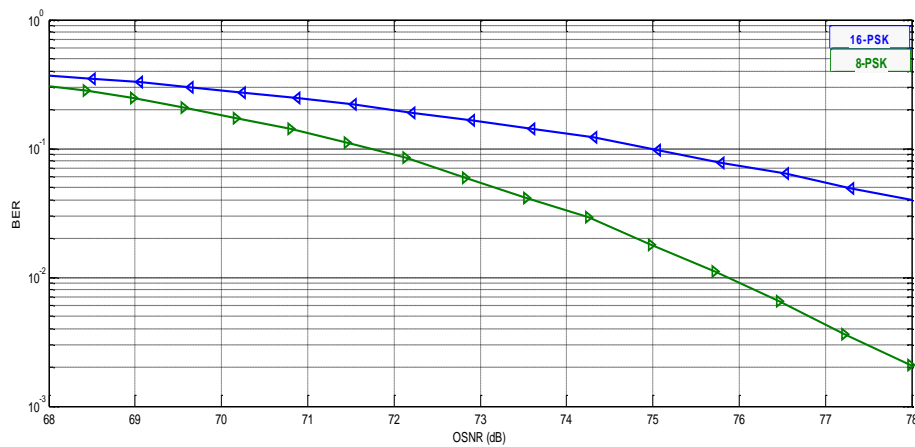

Figure 4. OSNR vs BER of received signal when 8-PSK and 16-PSK used at 20 Gb/s

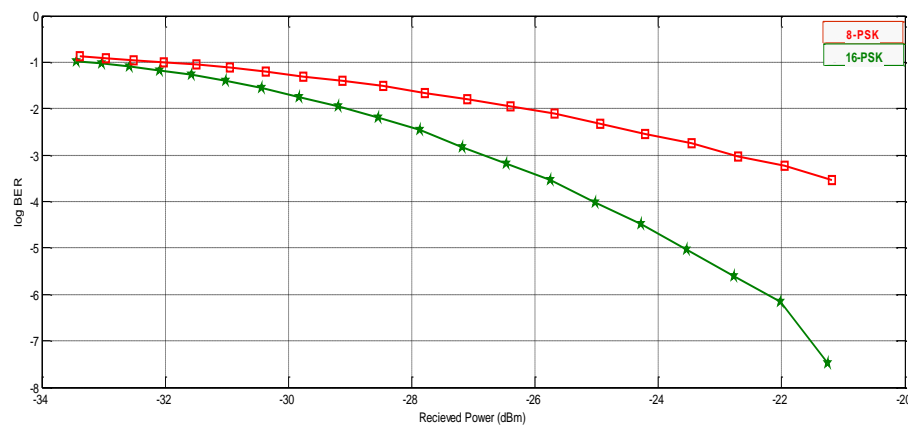

Figure 5. received power vs log of BER of received signal when 8-PSK and 16-PSK used at 20 Gb/s

## VI. 30 GB/S OFDM SIGNALS OVER 40-KM SMF

In this case the same procedures in part were applied with an increase in the bit rate value from 20 Gb/s to 30 Gb/s. The constellation diagram of all three modulations methods were impacted by this change as in Figure 6. Because of this increase, the constellation points of 8-PSK and 16-QAM became closer to each other while in 16-PSK they osculated each other. These crowded points in the constellation diagrams represent a received signal with low quality in all the three modulation techniques.

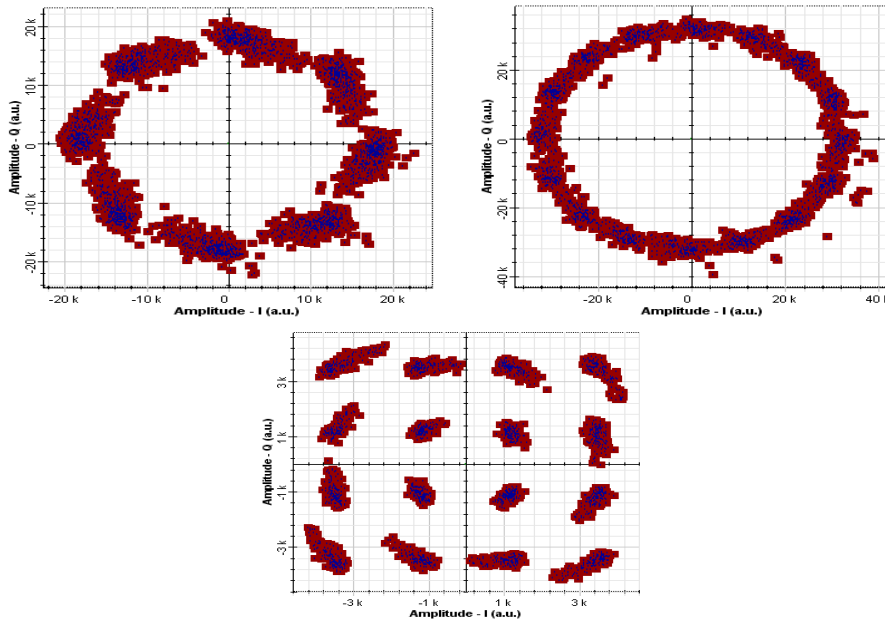

Figure 6. Constellation diagram of the received signal at different modulation of OFDM a) 8-PSK b) 16-PSK c) 16-QAM at 30 Gb/s upconverted

Table 2 has a comparison of the three modulation methods in OSNR and received power. The arrangement of which one of these methods has a highest OSNR and received power did not change with increasing the bit rate. The highest OSNR and received power happened when 16-QAM was used, while still almost the same values of OSNR and received power for both 8-PSK and 16-PSK. Even though, the bit rate increased the OSNR and received power of all methods did not dramatically decrease; however, a little drop happened.

Table 2. OSNR and received power of the received signal at different modulation formats at 30 Gb/s

	8-PSK	16-PSK	16-QAM
OSNR dB	78.5721	78.7345	97.2627
Received power (dBm)	-21.4279	-21.2655	-2.73728

Another evident to the impact of bit rate's increase is shown in Figure 7 which exhibits a plot of OSNR vs BER when 8-PSK and 16-PSK were used. The BER is still higher in 16-PSK, whilst it became high in both cases after the bit rate increase. Even though, only 50 % of bit rate was taken in to the system, the BER increased more than twice a value of the BER at bit rate 20 Gb/s. Figure 8 shows plot of received power vs a log of BER of 8-PSK and 16-PSK.

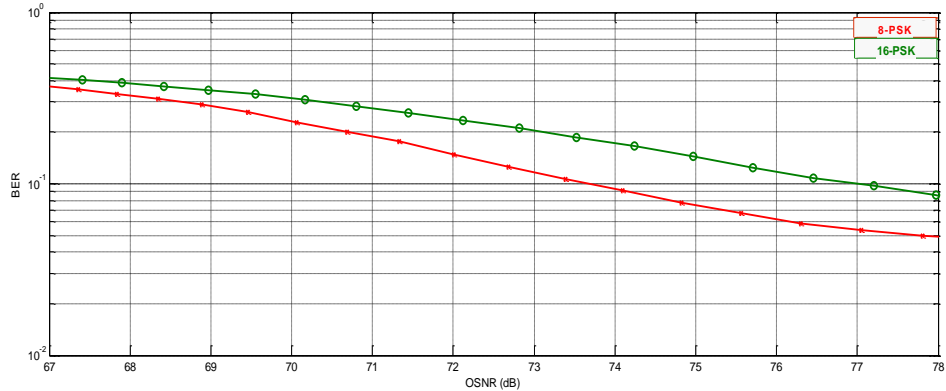

Figure 4. OSNR vs BER of received signal when 8-PSK and 16-PSK used at 30 Gb/s

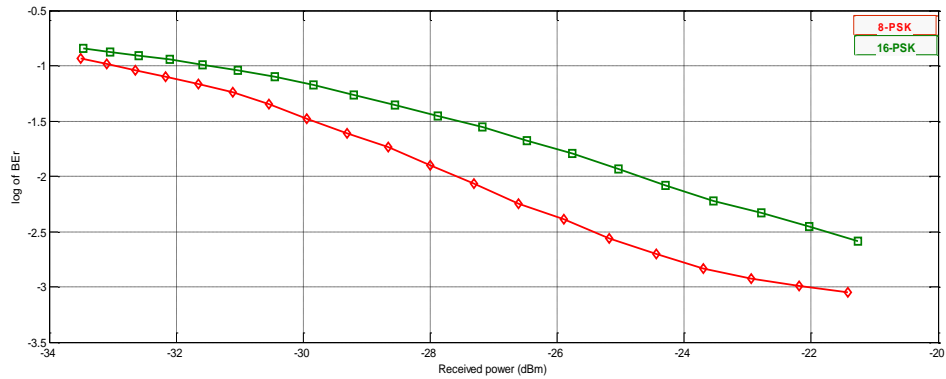

Figure 8. received power vs log of BER of received signal when 8-PSK and 16-PSK used at 30 Gb/s

## VII. CONCLUSION

In this paper we studied the BER performance in RoF-OFDM system that modulated by different modulation techniques such as QAM and PSK. The study was under to cases of up-converted 20 Gb/s and 30 Gb/s OFDM signals on 20-GHz microwave carrier over 40 km SMF. In both cases the lowest BER and the highest received power appeared when 16-QAM was used, while the highest BER occurred when 16-PSK modulation used. The capacity of 16-QAM and 16-PSK are almost the same; however, using 16-PSK is necessary when the received power is premium. As a comparison between using 8-PSK and 16-PSK we found using 16-PSK caused a higher BER than using 8-PSK. The increase in BER when 16-PSK used might refers to the difficulty in maintaining the orthogonality in the OFDM. After increase the bit rate to 30 Gb/s the BER values in all modulation cases are not clear evidence for having a received signals with high qualities.

## REFERENCES

- [1] A. Alateeq, K. Alatawi, F. Almasoudi, and M. A. Matin, "Design of Broadband RoF PON for the Last Mile" Scientific and research: Journal of communications and network, Vol. 4, pp 269-277, November, 2012
- [2] Zhensheng Jia, "*Optical millimeter-wave signal generation, transmission and processing for symmetric super-broadband optical-wireless access networks*" PhD Dissertation, Electrical Engineering, Georgia Tech, August, 2008
- [3] Chi, C. Yeh, and C. Chow, "Broadband access technology for passive optical network," broadband access communication technology III, Vol. 7234, 2009
- [4] C. Chow, C. Yeh, C. Wang, F. Shih, C. Pan, and S. Chi, "WDM extended reach passive optical networks using OFDM-QAM," Optics express, Vol. 16, No. 16, pp 12096-12101, Jul, 2008
- [5] B. liu, L. Zhang, X. Xin, and J. Yu, "Symmetric terabit WDM pre-DFT OFDM access network using PCF-supercontinuum," optics express, Vol. 20, No. 22, pp 24356-24363, October, 2012
- [6] S. Albdran, A. Alshammari, & M. Matin, M. "The Sensitivity of Bit Error Rate (BER) Performance in Multi-Carrier (OFDM) and Single-Carrier", SPIE optics and photonics, 2012
- [7] M. Hu, S. Wu, M. Fang, and L. Tang, "A wavelength reuse OFDM-WDM-PON architecture with downstream OFDM and upstream OOK modulations," ICCSN, 2011 3<sup>rd</sup> international conference on, pp 389 – 392, 2011.
- [8] N. Nowshin, A. Arifuzzman, and M. Tarique, "Demonstration and performance analysis of RoF based OFDM-PON system for next-generation fiber optic communication," International J of computer networks & communications, Vol. 4, no. 1, pp 193-209, January 2012.
- [9] C. Lin, Y. Lin, J. Chen, S. Dai, P. Shih, P. Peng, and S. Chi, "Optical direct-detection OFDM signal generation for radio-over-fiber link using frequency doubling scheme with carrier suppression," Optical express, Vol. 16, No. 9, pp 6056-6063, 28 April 2008
- [10] X. Hu, L. Zhang, P. Cao, K. Wang, and Y. Su, " Energy-efficient WDM-OFDM-PON employing shared OFDM modulation modules in optical line terminal," optics express, Vol. 20, No. 7, pp. 8071-8077, March, 2012
- [11] J. Huang, D. Liu, and C. Zeng, " 10 Gb/s WDM-PON using downstream OFDM and upstream OOK," computer and information science, Vol. 4, No. 2, pp 34-38, March, 2011

# Design of Broadband RoF PON for the Last Mile

**Ayoob Alateeq, Khaled Alatawi, Fahad Almasoudi, Mohammad A. Matin**

Department Electrical and Computer Engineering, University of Denver, Denver, USA

Email: Ayoob.alateeq@du.edu

Received August 24, 2012; revised September 22, 2012; accepted October 25, 2012

## ABSTRACT

An increase in the demand of broadband service has encouraged research and study to find a solution to offer an adequate amount of service. Living in this digital world with downloading video, voice or data leads us occasionally to have a shortage of bandwidth in the provided data. One of the solutions to cover the huge expected demand in the future is improving the communication systems by adding optical passive components to the Radio over Fiber (RoF) system. This work is mainly to increase the bandwidth that allows the small and single consumer at the last mile. We have shown that by adding the 40-GHz mm-wave to the system, Bit-Error-Rate (BER) has increased while Q-factor has de-creased.

**Keywords:** WDM-PON; MM-Wave Radio; RoF; Q-Factor; BER

## 1. Introduction

In the modern communication systems, optical fiber is used to promote the efficiency in the transmitting and the receiving signals. This development in the communication system will help to supply enough broadband service to the last point of each individual consumer. Providing broadband service to each single end would not be an easy task to the service providers. Not only does optical fiber have immunity to the electromagnetic field, it also offers a high bandwidth that might be needed at the end of a single terminal. Distributing services to each single end will be costly. However, by using the wavelength division multiplexer (WDM), which works to transmit one signal with many wavelengths, one fiber, is needed to connect the wavelength division multiplexing to the demultiplexing at the end of the transmitter side and the beginning of the receiver side. Fiber to terminal x technology (FTTx) has shown its ability to increase the bandwidth at the last mile terminals such as small businesses and housing customers. The passive optical network (PON), which consists of, the optical line terminal (OLN), the single mode fiber optic (SM), and the optical network terminal (ONT), is simply a (FTTx) technology. WDM PON systems can also offer symmetric wavelengths, both downstream (from OLN to ONT) and upstream (from ONT to OLN) [1]. Moreover, for the wire-

less broadband technology mm-wave radio shows its efficiency in supporting the wireless connections. In this paper, we have found the function of WDM-PON systems which requires having all passive optical components and studying the system after adding the optical fiber to the last mile terminal [2]. We also have added mm-wave to the carrier signal in order to take the advantage of mm-wave.

The demand for a high-speed data rate has increased over the last few years. The traditional networks that use coaxial cable and wireless communication have become insufficient to provide high data and large bandwidth. To overcome this problem, an optical fiber must be used because it can provide large bandwidth and a high data transfer rate. The use of the passive optical network (PON) is the most efficient and economic way to solve this problem because of its characteristics. The passive optical network has many advantages. For instance, it does not use active devices such as optical amplifiers, repeaters and active splitters especially between the central offices and the base stations. Therefore it consumes less power, less space, and less complexity. Because of this it can be expanded cheaply as compared to the active network [3].



## 2. System Design

The most dominant use of the passive optical network is to provide high speed, large bandwidth, and a high data rate to the end user at the last mile. The demand for using the Internet service for gaming, video calling, and high-definition television has been increased by the end users [1]. Therefore, this will require large bandwidth and a high data rate. The main goal of this project is to provide high-speed Internet services to the last mile by using fiber to the home, which is known as FTTH. In this study we used the broadband passive optical network, Which is known as BPON to implement the FTTH network and adding mm-wave to the carrier and finding the effects that mm-wave apply to the output signal.

In this paper we design and analysis a broadband passive optical network (BPON-RoF) to achieve a high-speed data rate and large bandwidth. We have built our system in two different designs one is without a mm-

wave and the second one is with a mm-wave. OptiSystem software version 10 was used to simulate those two designs. **Figure 1** shows the basic Architecture of WDM-PON network. **Figure 2** represents our whole

model after adding the 40-GHz mm-wave. We use two transmitters that have been used to generate two different wavelengths of 1510 and 1530 nm, respectively. The two wavelengths have been combined using a WDM multiplexer. After that the signal has been inserted in the bidirectional single mode optical fiber. After using the bidirectional SM optical fiber a splitter was used as in **Figure 3**. The splitter block contains the WDM demultiplexer to separate the two wavelengths in the downstream. For the upstream the splitter block contains WDM in order to combine the wavelengths that will be

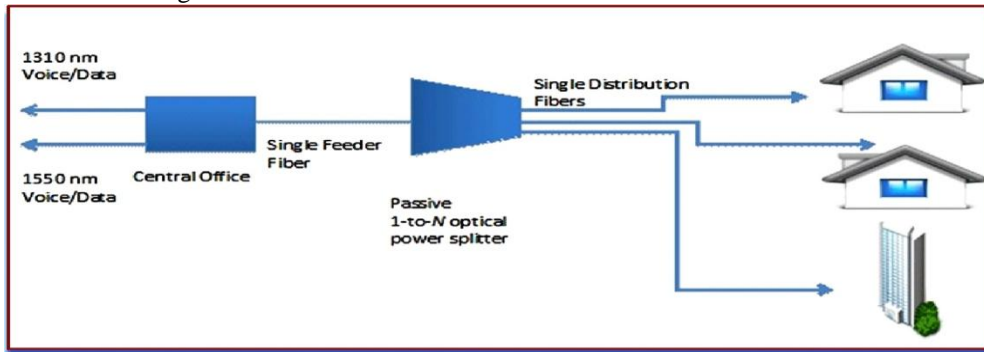

Figure 1. Basic architecture of WDM-PON network.

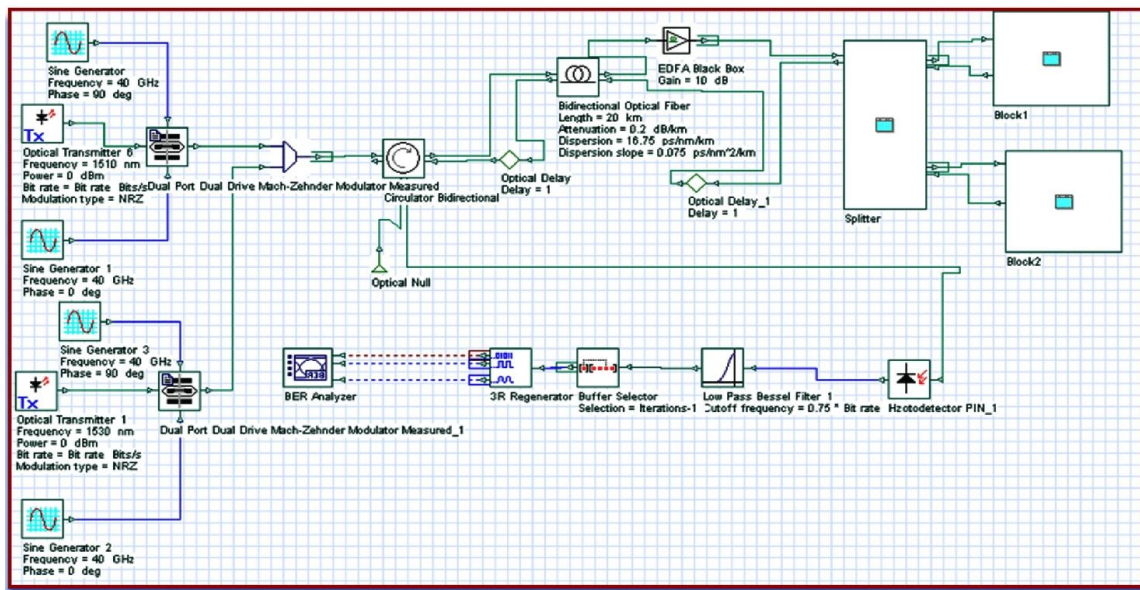

Figure 2. System model.



sent by the end users. For the downstream the two wavelengths that were demultiplexed will be transmitted to the two optical network terminals (ONTs). Each ONT contains an optical splitter and to optical network units (ONUs). The signal that comes from the splitter block will be inserted into the splitter through 3 Km bidirectional optical fiber, after dividing the signal each output port from the splitter will deliver a signal to an ONU through 50 m bidirectional optical as shown in **Figure 4**. Each ONU consists of a photodetector with a low pass filter for the downstream and a transmitter for the upstream signals as shown in **Figure 5**. At each of the

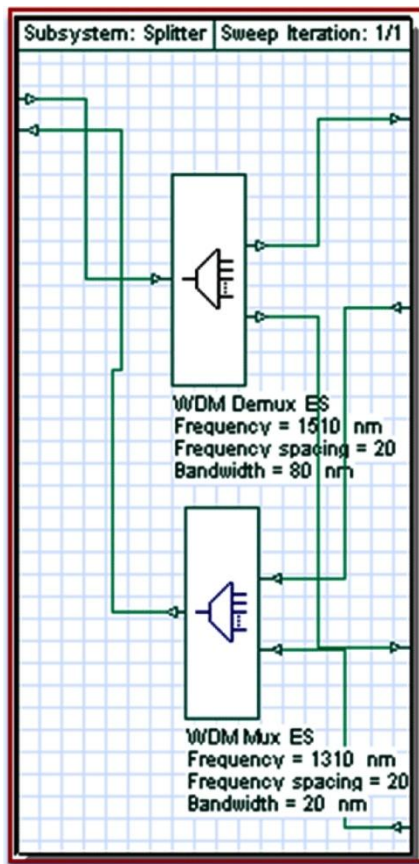

Figure 3. Splitter Circuit with WDM Mux and Dmux.

ONUs the transmitter's wavelength is 1310 nm. Since we have four transmitters with the same wavelength that may transmit their information at the same time, we take the advantage of time division multiplexing access (TDMA) to design the upstream system. TDMA has been designed by using two dynamic y select that will pass the signal upstream in a determined period of time and will set the rest of the signals to zero **Figure 5**. The receiver end of the upstream link consists of a buffer selector to select the desired signal. A photodetector with low pass filter is connected to the buffer selector. By using dual-arm MZM in the input side, we have inserted 40-GHz mm-wave signal based on optical carrier suppression (OCS) to the input signal 1510 and 1530 nm for the downstream link; however, for the upstream link out of MZM was connected to the input of the selectors [3-5].

### Design Studying Parameters

After designing the system, three parameters were tested to study the performance of the network and the quality of the signal. These parameters are the Q-factor, the bit error rate and the eye diagram. The Q-factor is the quality factor; a higher Q-factor indicates a higher signal quality. On the other hand, the bit error rate (BER) is the ratio between the number of the bits with errors and the total number of bits received and it helps to identify the quality of the optical connection. The eye diagram is one of the important methods to study the system. The eye opening can indicate the noise in the signal and how it differentiates the logic 0 from logic 1. The eye width can indicate the jitter effect and the rising or falling edge can indicate the distortion of the signal path [6,7].

### 3. Results

After designing this PON, a number of parameters have to be considered such as bit rate, sequence length, samples per bit and the total samples. In the case we have studied this system is at 2.5 G/s as a bit rate, the sequence length is 128 bits, samples per bit are 64 and the total number of samples is 8192.

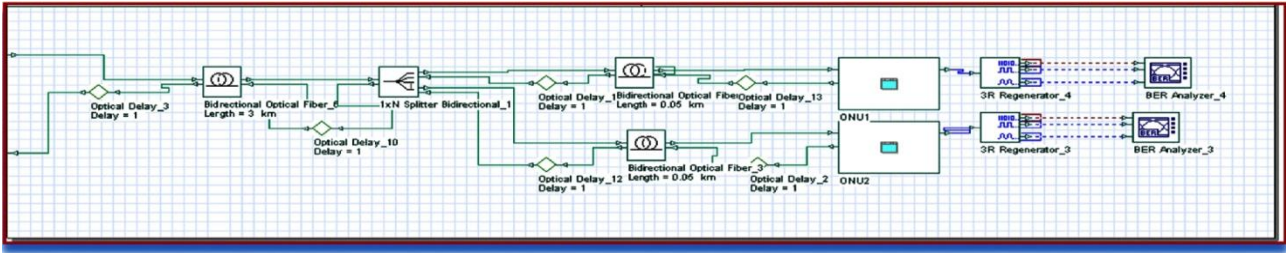

Figure 4. Passive optical network for one block.

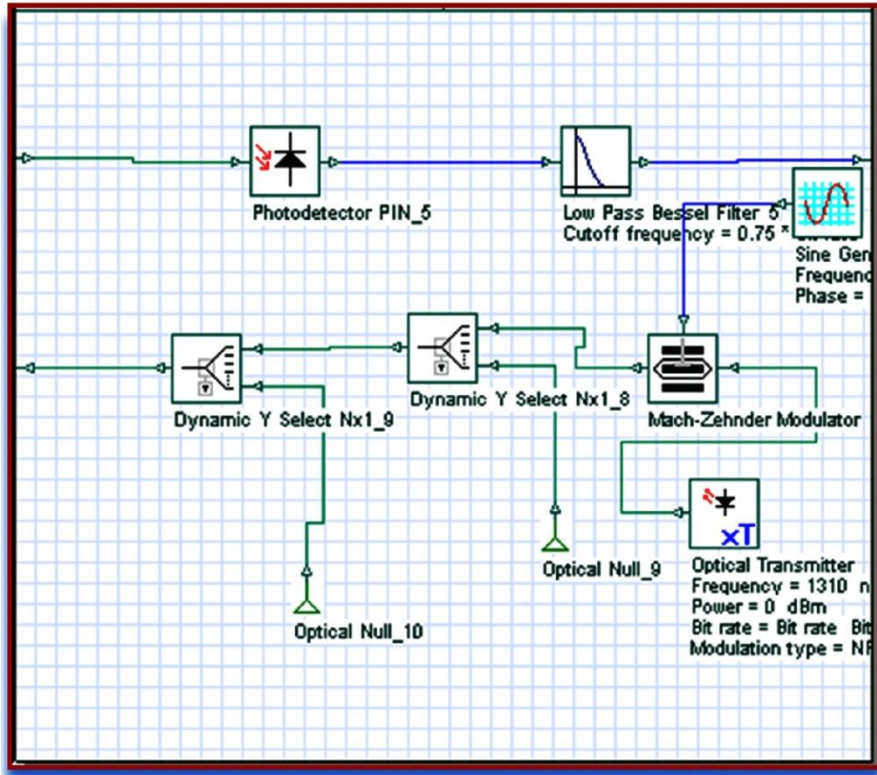
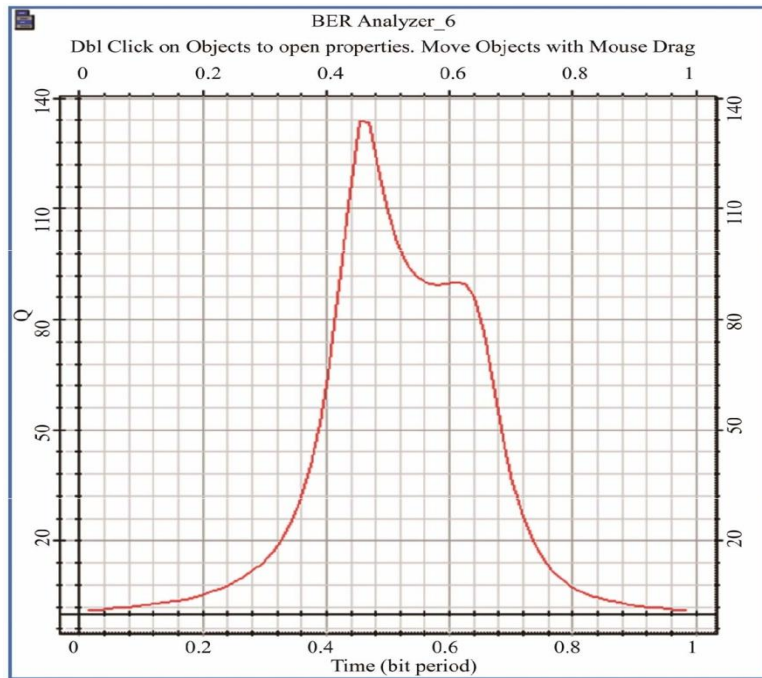
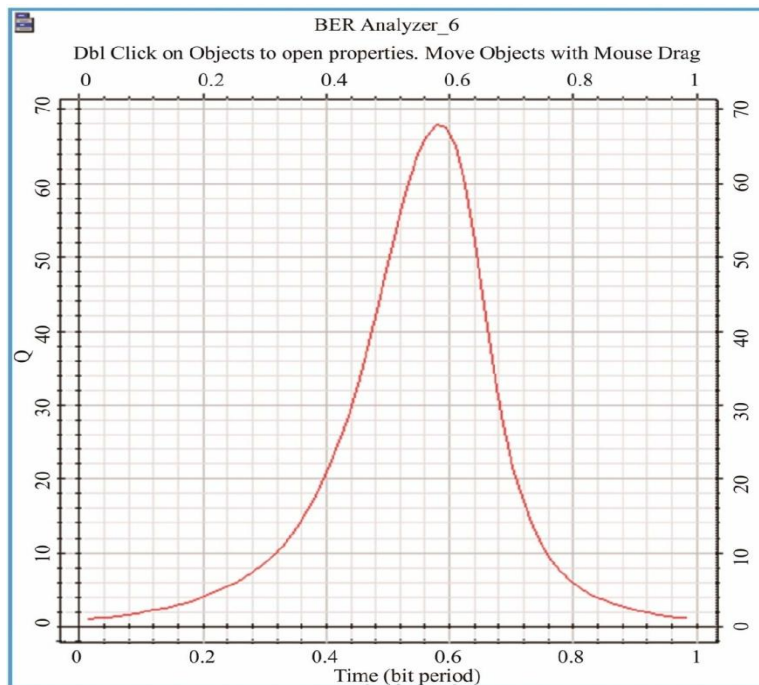

Figure 5. Optical network unit (ONU).



(a)



(b)

Figure 6. Q-factor vs. time for downstream signal with (b) and without (a) 40-GHz mm-wave.

### 3.1. Downstream Design Analysis

For the downstream signal with and without adding mm-wave to the system, **Table 1** shows the important output of BER, Q-factor and eye diagram which are at one single user. Because of having almost identical out-puts for each one of the four users, we have analyzed the quality of the signals at only one single user. From **Figure 6(a)**, the maximum Q-factor is equal to 133.819; however, after adding 40 -GHz mm-wave to the system has the Q-factor is equal to 67.909 as shown in **Figure 6(b)**. These two values of Q-factor are high enough for having a good quality of the output signal and have achieved the desired value of the Q-factor. BER for the downstream signal is zero which means the Q-factor has reached its maximum. **Figure 7** portrays the eye diagram of the downstream signals. From this figure, it can be clearly seen that the opening eye is large and clear which means this signal is very good with little noise and distortion and it is easy to distinguish between logic 0 and logic 1 [8,9].

### 3.2. Upstream Design Analysis

Before running the upstream design, seven iterations have to be set in order to operate the design. Seven iterations are needed because each upstream signal from any

**Table 1. Downstream signal details with and without 40-GHz mm-wave.**

	Without 40-GHz mm-wave	With 40-GHz mm-wave
Max. Q-factor	133.819	67.909
Min. BER	0	0
Eye height	0.008254238	0.00765657
Threshold	0.00200062	0.00347784
Decision inst	0.5	0.5

individual user will go through seven time delays before reaching the upstream receiver. **Table 2** shows the most important details of the upstream signal with and without the mm-wave. From this table, the BER values are larger than the BER values of the downstream signals; however, the Q-factor values are smaller than those of the downstream design as shown as in **Figure 8**.

This decrease in Q-factor and the increase in BER values lead us to have a signal with lower quality than the quality of the downstream signals. Even though the upstream signal is a good signal, it is not as good as the downstream signal. The eye diagram of the upstream signals shows in **Figure 9**, that this signal has noise and distortion which are larger than those of the downstream signal.

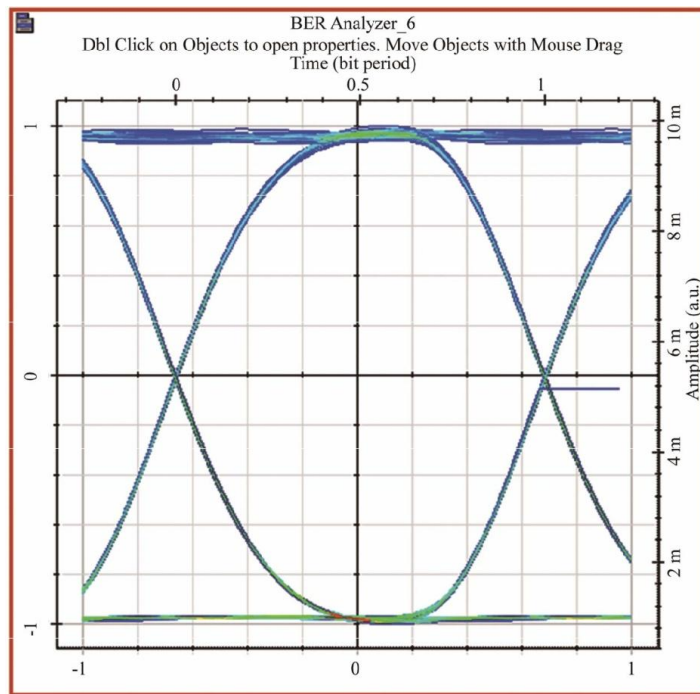

(a)

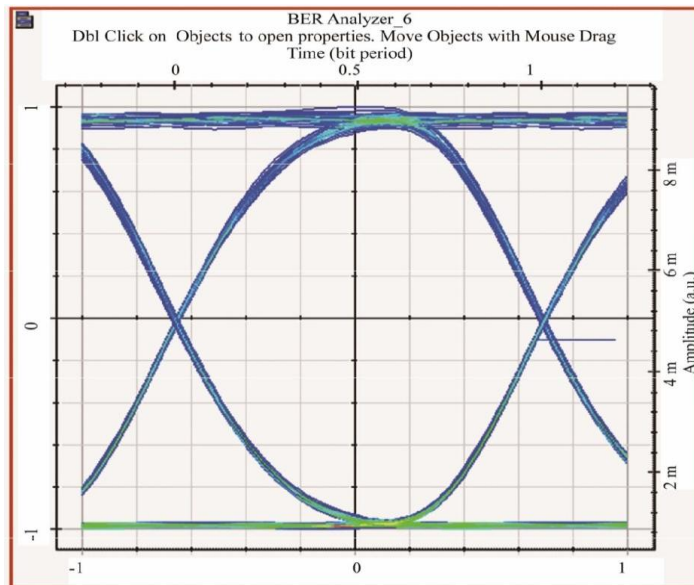

(b)

Figure 7. Eye diagram of the downstream signal with (b) and without (a) inserting 40-GHz mm-wave.

**Table 2. Upstream signal details with and without Rf generator.**

	Without Rf generator	With Rf generator
Max. Q-factor	8.09842	3.90774
Min. BER	1.6922e-016	1.50805e-005
Eye height	0.000345197	5.84756e-005
Threshold	0.000318945	0.000103043
Decision inst	0.375	0.359375

BER Analyzer\_6  
 Double Click on Objects to open properties. Move Objects with Mouse Drag

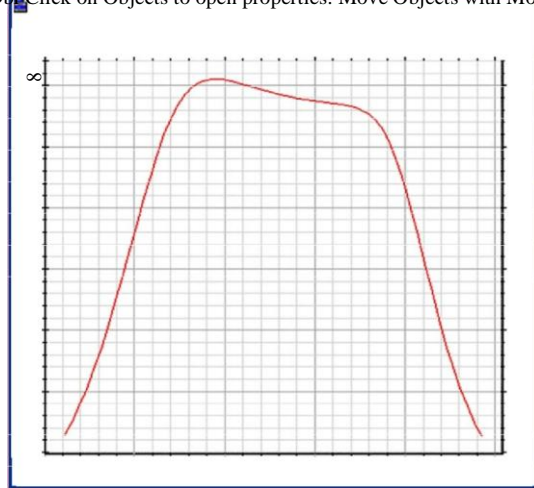

(bit period)

(a)

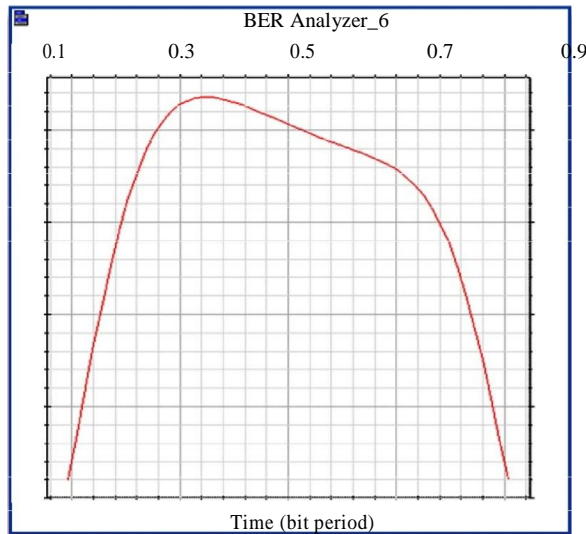

Time (bit period)

(b)

**Figure 8. Q-factor vs. time for upstream signal with (b) and without (a) inserting 40-GHz mm-wave.**



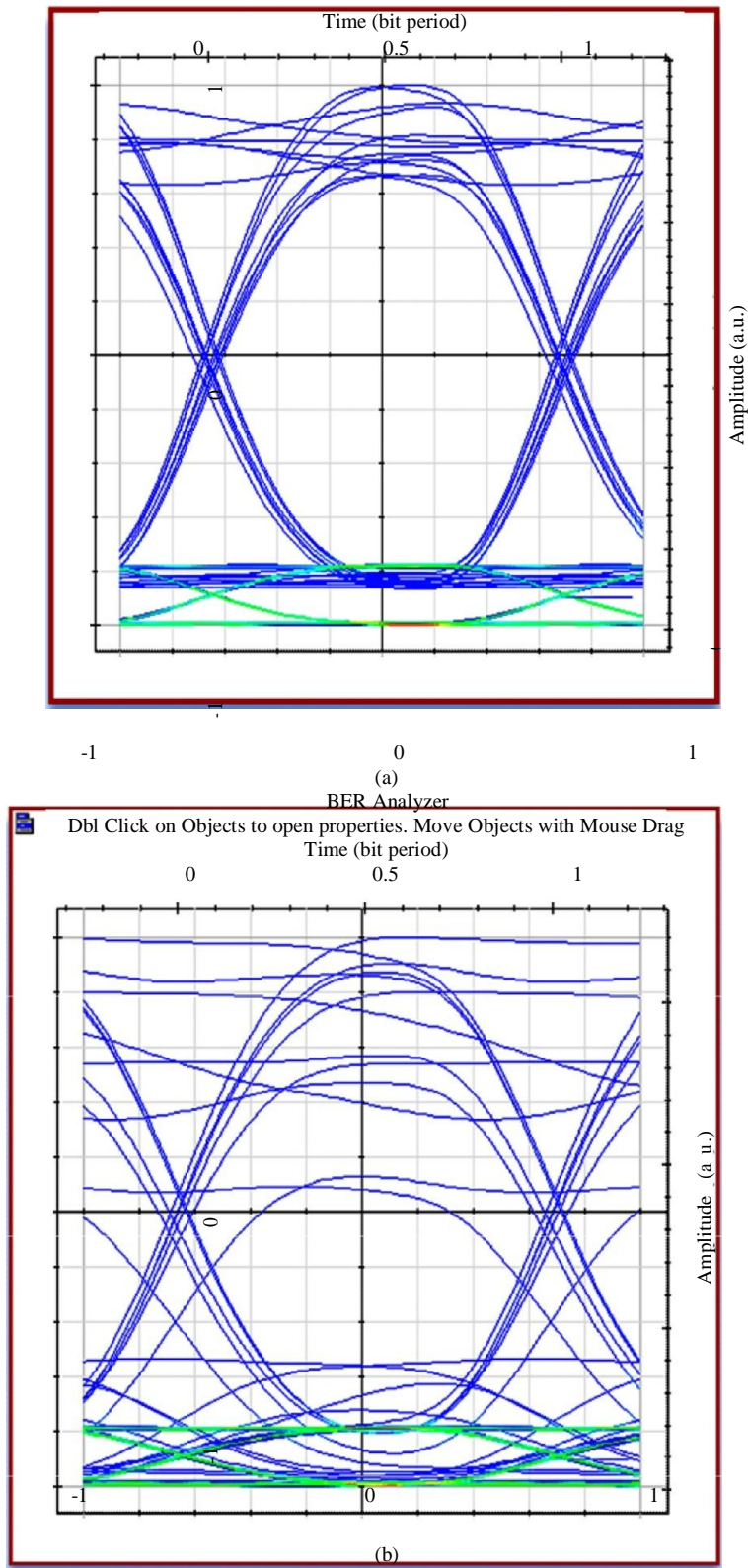

Figure 9. Eye diagram of the upstream signal with (b) and without (a) inserting 40-GHz mm-wave.

#### 4. Conclusion

The results showed that the BER of the signal was very low and the eye diagram showed the quality of the signal for the downstream was very high before adding the 40-GHz mm-wave; however, after adding the mm-wave to the system BER has increased and Q-factor has decreased as a result the quality of the signal was affected by mm-wave. But for the upstream signals, as the eye diagram showed, the quality was good but not as high as the downstream signal because in the downstream a lot of equipment was used including amplifiers and filters. The qualities of the signals were decreased after adding the mm-wave; however, there are still acceptable. Building BPON system in general has showed high reliability. In general using PON has a lot of advantages which include allow costs, very low power consumption and flexi-bility in extending the network.

#### REFERENCES

- [1] J. S. A. Pla, "Design of Passive Optical Network," Department of Telecommunications, Faculty of Electrical Engineering and Communication, Brno University of Technology, Brno, 2011.
- [2] W. Stephen and T. Wang, "The Comsoc Guide to Passive Optical Networks Enhancing the Last Mile Access," John Wiley & Sons, Chichester, 2012.
- [3] R. Poboril, J. Latal, P. Koudelka, J. Vitasek, P. Siska, J. Skapa and V. Vasinek, "A Concept of a Hybrid WDM/TDM Topology Using the Fabry Perot Laser in the Opti-wave Simulation Environment," *Advances in Electrical and Electronic Engineering*, Vol. 9, No. 4, 2012, pp. 167-178.
- [4] Z. Jia, "Optical Millimeter-Wave Signal Generation, Transmission and Processing for Symmetric Super-Broadband Optical-Wireless Access Networks," Ph.D. Dissertation, Electrical Engineering, Georgia Tech, 2008.
- [5] L.-J. Zhang, X.-J. Xin, B. Liu, Q. Zhang, Y.-J. Wang and C.-X. Yu, "Broadband Convergence of 40 GHz-ROF and 10-Gb/s WDM-PON Systems in the Duplex Access Network," *Chinese Physics Letters*, Vol. 27, No. 5, 2010, p. 054203. [doi:10.1088/0256-307X/27/5/054203](https://doi.org/10.1088/0256-307X/27/5/054203)
- [6] S. Rajalakshmi, A. Srivastava and A. Pandey, "RSOA Based 10 G WDM for Long Reach PON Using Manchester Coding for Re-Modulation," *International Journal of Engineering Science and Technology*, Vol. 4, No. 4, 2012, pp. 1767-1775.
- [7] N. S. Afifi, M. Othman and Z. Tukiran, "Optimization for the Best Performance for Wavelength Division Multiplexed Passive Optical Network," *Proceedings of Engineering Conference*, 2008, pp. 1038-1043.
- [8] G. Keiser, "Optical Fiber Communications," McGraw-Hill Education, New York, 2011.
- [9] J. Zhang and N. Ansari, "Design of WDM PON with Tunable Lasers: The Upstream Scenario," *Journal of Lightwave Technology*, Vol. 28, No. 2, 2010, pp. 228-2