

University of Denver

Digital Commons @ DU

Electronic Theses and Dissertations

Graduate Studies

1-1-2012

Performance Study of OFDM over Fading Channels for Wireless Communications

Ahmed Alshammari
University of Denver

Follow this and additional works at: <https://digitalcommons.du.edu/etd>



Part of the [Computer Engineering Commons](#), and the [Electrical and Computer Engineering Commons](#)

Recommended Citation

Alshammari, Ahmed, "Performance Study of OFDM over Fading Channels for Wireless Communications" (2012). *Electronic Theses and Dissertations*. 748.
<https://digitalcommons.du.edu/etd/748>

This Thesis is brought to you for free and open access by the Graduate Studies at Digital Commons @ DU. It has been accepted for inclusion in Electronic Theses and Dissertations by an authorized administrator of Digital Commons @ DU. For more information, please contact jennifer.cox@du.edu, dig-commons@du.edu.

PERFORMANCE STUDY OF OFDM OVER FADING CHANNELS FOR WIRELESS
COMMUNICATIONS

A Thesis

Presented to

The Faculty of Engineering and Computer Science

University of Denver

In Partial Fulfillment

of the Requirements for the Degree

Master of Science

by

Ahmed Alshammari

November 2012

Advisor: Dr. Mohammad Matin

© Copyright by Ahmed Alshammari

2012 All Rights Reserved

Author: Ahmed Alshammari
Title: PERFORMANCE STUDY OF OFDM OVER FADING CHANNELS FOR
WIRELESS COMMUNICATIONS
Advisor: Dr. Mohammad Matin
Degree Date: November 2012

ABSTRACT

Orthogonal Frequency Division Multiplexing (OFDM) is a very efficient multicarrier technique. OFDM is used more and more in recent wideband digital communications. It has numerous advantages such as the ability to handle severe channel conditions, efficient spectral usage, reduced inter symbol interference (ISI), and high data rate. Therefore, it has been utilized in many wired and wireless communication systems like DSL, wireless networks and 4G mobile communications.

Studying the performance of OFDM over different channels is the main focus of this research. Channels' environments simulated in Matlab are additive white Gaussian noise (AWGN) and fading channels. Each channel affects the process of transmission in a certain way. Simulation results will make us understand some of these effects.

Fading channels include two types of flat fading and two types of frequency selective fading. At certain signal-to-noise ratios (SNRs), channels are compared together in order to rank them according to the delivered signal. Quality of the signals, bit-error-rates (BERs), and peak signal-to-noise ratios (PSNRs) of the received signals are the aspects in which system performance is evaluated.

Acknowledgments

My sincere gratitude goes to my advisor Dr. Mohammad Matin whose supervision was of a great help in accomplishing this research. I also appreciate his role in increasing my confidence throughout my two years at DU. Thanks to all of my defense committee members, Dr. David Gao and Dr. Ramakrishna Thurimella, for their cooperation and support.

I would like to express love and thanks to my parents who have always been the guide of my life. I would also like to thank all of my family members for their support, encouragement and trust because this is always what pushes me forward.

Table of Contents

Abstract.....	ii
Acknowledgements	iii
List of Figures.....	vi
List of Abbreviation	viii
Chapter One: Introduction	
1.1 Goals of This Research	2
1.2 Scope of This Research.....	3
1.3 Motivation to Research OFDM	3
1.4 Statement of the Problem.....	4
1.5 Methodologies and Report Structure	4
Chapter Two: Background	
2.1 Parallel Transmission.....	6
2.2 Basic Principle of OFDM	7
2.3 Important OFDM Parameters	8
2.4 OFDM Model	11
2.5 Advantages of OFDM.....	13
2.5.1 Tolerance towards Multipath Delays.....	13
2.5.2 Robustness against Channel Distortion	13
2.5.3 Capacity Transmission.....	14
2.5.4 Effectiveness against Impulse Noise	14
2.5.5 Frequency Diversity.....	15
2.6 Disadvantages of OFDM	15
2.6.1 Peak Average Power Ratio	15
2.6.2 Sensitivity to Frequency Errors	16
2.7 Applications of OFDM	16
2.7.1 Digital Audio Broadcasting (DAB)	16
2.7.2 Digital Video Broadcasting (DVB)	17
2.7.3 Wireless LANs	17
2.7.4 OFDMA	17
2.7.5 Fourth Generation (4G)	18
Chapter Three: Communication Channel	
3.1 Fading	20
3.2 Kinds of Small Scale Fading	23
3.2.1 Fading from Multipath Time Delay Spread.....	23
3.2.2 Fading from Doppler Spread	24

3.3 Factors Affecting Small Scale Fading	25
3.4 Communication Channel Model	27
3.4.1 Delay Spread Parameters	29
3.4.2 Doppler Spread Parameters	32
3.5 Rayleigh Distribution	34
3.6 Multipath Fading Model	35
3.6.1 Clarke's Model	35
Chapter Four: Simulation Results	
4.1 Trial of the OFDM Simulation	40
4.2 Transmission over AWGN Channel	43
4.3 Transmission over Multipath Fading Channels	46
4.3.1 Flat Fading Channels	46
4.3.2 Frequency Selective Fading Channels	51
4.4 Discussion of the Results	56
Chapter Five: Conclusion and Future Work	
5.1 Conclusion	59
5.2 Future Work	60
References	61
Appendix A	65
Appendix B	81

List of Figures

Figure 1.1 Flowchart of the Thesis	5
Figure 2.1 Benefits of the Guard bands	8
Figure 2.2 Spectrum of Orthogonal OFDM Subcarriers	9
Figure 2.3 Block Diagram of OFDM Modulation and Demodulation	10
Figure 2.4 OFDM System Block Diagram	12
Figure 3.1 Multipath Environment	20
Figure 3.2 Fading Channel Manifestation	22
Figure 3.3 Delay Spread	24
Figure 3.4 Doppler Spread.....	25
Figure 3.5 Small Scale Fading Based on Multipath and Doppler Spread	27
Figure 3.6 Moving Receivers	29
Figure 3.7 Normalized Exponential Power Delay Profile	31
Figure 3.8 Normalized Gaussian Power Delay Profile.....	31
Figure 3.9 Doppler Spectrums	33
Figure 3.11 PDF of Rayleigh Distribution.....	34
Figure 3.12 Received Wave with Angle of Arrival	36
Figure 3.13 Simulator of Raleigh Fading	38
Figure 4.1 Test Image	40
Figure 4.2 Program Run Times.....	42
Figure 4.3 BER vs. SNR.....	42
Figure 4.4 BER vs. MPSK.....	43
Figure 4.5 Image Sent over AWGN Channel.....	44
Figure 4.6 (a) BER over AWGN Channel.....	45

Figure 4.6 (b) PSNR over AWGN Channel.....	45
Figure 4.7 Image Sent Over Flat Slow Fading Channel with Different SNRs	47
Figure 4.8 (a) BER over Flat Slow Channel.....	47
Figure 4.8 (b) PSNR over Flat Slow Channel.....	48
Figure 4.9 (a) Image Sent Over Flat Fast Fading Channel with Different SNRs	49
Figure 4.10 (a) BER over Flat Fast Channel.....	50
Figure 4.10 (b) PSNR over Flat Fast Channel	50
Figure 4.11 Image sent over Frequency Selective Slow Fading Channel	52
Figure 4.12 (a) BER over Frequency Selective Slow Channel.....	53
Figure 4.12 (b) PSNR over Frequency Selective Slow Channel	53
Figure 4.13 Image sent over Frequency Selective Fast Fading Channel.....	54
Figure 4.14 (a) BER over Frequency Selective Fast Channel	55
Figure 4.14 (b) PSNR over Frequency Selective Fast Channel.....	55
Figure 4.15 (a) Comparing BER of the Different Channels	57
Figure 4.15 (b) Comparing PSNRs of the Different Channels	57

List of Abbreviation

AWGN (Additive White Gaussian Noise)
ADC (Analog to Digital Converter)
BER (Bit Error Rate)
BPSK (Binary Phase Shift Keying)
CP (Cyclic Prefix)
DAC (Digital to Analog Converter)
DFT (Discrete Fourier Transform)
DTV (Digital Television)
ETSI (European Telecommunication Standards Institute)
FDM (Frequency Division Multiplexing)
FDMA (Frequency division Multiple Access)
FFT (Fast Fourier Transform)
ICI (Inter Carrier Interference)
IDFT (Inverse Discrete Fourier Transform)
IFFT (Inverse Fast Fourier Transform)
ISI (Inter Symbol Interference)
LAN (Local Area Network)
LOS (Line of Sight)
LTE (Long Term Evolution)
MIMO (Multiple Input Multiple Output)
PAPR (Peak to Average Power Ratio)
PDF (Power Density Function)
PSK (Phase Shift Keying)

QAM (Quadrature Amplitude Modulation)

QPSK (Quadrature Phase Shift Keying)

TDMA (Time Division Multiple Access)

Wi-Fi (Wireless Fidelity)

WiMAX (Worldwide Interoperability for Microwave Access)

WLAN (Wide Area Network)

WLAN (Wireless Local Area Network)

Chapter One: Introduction

The problems of inter symbol interference (ISI) in single carrier communication systems is significantly reduced when the symbol period is made bigger than the time delay [3]. However, having long symbol period results in a very low data rate, which makes the communication system inefficient. Therefore, single carrier communication is not enough to transfer data at a high rate.

Demand for broadband communications is increasing every day. Multicarrier communication is used to meet that increasing need [31]. Frequency division multiplexing (FDM) is a multicarrier technique that subdivides the spectrum of the communication channel to transmit data in parallel through multiple carriers [3]. Inter-carrier interference (ICI) is another possible problem, in this case, since carriers are so closely spaced to achieve a high data rate. This issue is resolved by placing guard bands between carriers, which lowers the data rate as a trade off.

Currently, OFDM is the most common technique for many communication systems because of its ability to provide high speed without facing the problem of ICI and ISI [47]. In fact, it is considered to be the dominant communication technique that can handle a digital multimedia application [32].

OFDM has drawn the attention as a multicarrier technique modulation during the last decade. It had emerged in the 1960's, but it was not utilized as a transmission technique until the demand for multimedia transmission had increased, driven by the growth of the wireless technology industry [7]. Communication channels usually affect high data rates sent over high bandwidth carrier frequency in wireless communication.

OFDM is considered to be a special case of FDM [3]. An intuitive understanding of the difference between FDM and OFDM channels is to think of the water flow coming out of a faucet as the FDM channel and the water coming from the shower as the OFDM signal. ISI and multipath fading effects have been minimized by sending data in parallel subcarriers and at a low data rate. OFDM is efficiently utilized in many applications such as the wireless local area network (WLAN), fourth generation communications 4G LTE and digital audio broadcasting (DAB) [1][9][34].

1.1 Goals of This Research

- Studying OFDM technology in a wireless environment
- Using computer simulation to design and analyze the performance of OFDM over multipath propagating channels
- Using a JPG image as a test signal
- Obtain values of BER & PSNR vs. SNRs for the different channels used

1.2 Scope of This Research

This research begins with general information about OFDM. It then gives an overview of multipath channels and the model used to simulate them. The last chapter shows and discusses simulation results. The interest of this research is to study the performance of OFDM over five distinct kinds of channels:

- AWGN Channel
- Multi-path fading channels
 - a) Flat fading
 - b) Frequency selective
 - c) Fast fading
 - d) Slow fading

1.3 Motivation to Research OFDM

Most of Wireless LAN systems currently apply OFDM. It is relatively new to the communication industry and there are many enhancements to OFDM that are expected in the future. Therefore, OFDM is one of the promising research areas. By designing and evaluating a model of OFDM using MATLAB, it would enable me to enter the field of researching cutting edge technologies that could influence the industry of communications. MATLAB is one of the most efficient tools for researching the area of communications. Hence, it was chosen to design and simulate this research.

1.4 Statement of the Problem

Unlike wired channels, wireless channels can be unpredictable because they may operate under strict and difficult environment circumstances such as delay, Doppler spread, shadowing or multipath fading. These conditions can occur due to the mobility of the receiver or the size of communication environment. In wireless communications, signals that reach the receiver by more than one path are known as a multipath propagating signal. They are usually received with different phase offsets that result in fading signals, with part of their energy canceled. The cancellation and fading amount depends on the delay spread.

This research is concerned with studying OFDM by analyzing the system performance over multipath fading channels. It studies OFDM performance with those channels after analyzing the simulation results. Results would include BER, PSNR, run times as well as visual comparison between the input and output image.

1.5 Methodologies and Report Structure

Stages of conducting this research are illustrated in figure 1.1. The research consists of three main parts: theoretical research; simulating the communication model and finally, comparing results from different aspects.

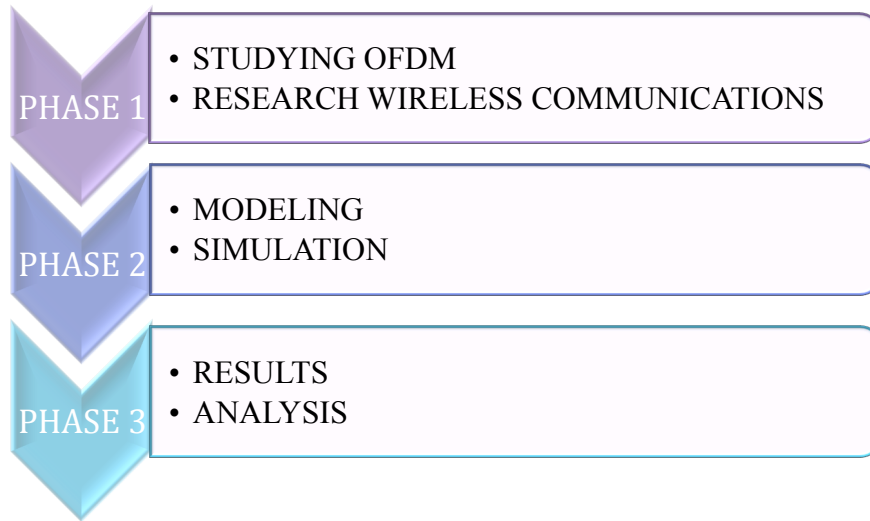

Figure 1.1 Flowchart of the Thesis

Chapter Two: Background

2.1 Parallel Transmission

When many versions of the signal are received at different times, the impulse response of the channel provides information about fading situations. This information enables us to know the approximate instances of reception, power, and phase of the signal. This is considered to be a very big issue in single carrier communications because very complicated equalization techniques are needed to get the correct impulse response of the channel. This is particularly true if about several megabits per second.

Parallel transmission has been introduced in order to avoid this issue, especially in a multipath-fading environment. It is also capable of carrying out broadband communications via sending parallel data in several channels instead of single high-speed stream.

To understand the effect of parallel transmission we have to think of a certain data rate. The more parallel channels are used to transmit this data rate, the more the data rate is reduced per channel. As a result, we end up with a longer symbol period that will result in eliminating the effect of the delay in the received signal.

2.2 Basic Principle of OFDM

OFDM is based on the idea of multicarrier modulation that was introduced in the mid 60's [15]. Data is represented in the form of bits in digital communications and the term symbol indicates a group of different sizes of bits [17]. M-PSK or QAM symbols are used to generate OFDM data. Symbols are then converted to N parallel streams by means of serial to parallel converters. The task of the different subcarriers is to carry out each of the N symbols. Inverse Discrete Fourier Transform (IDFT) converts to the time domain. It is applied in this case because it is more efficient, [3]. All OFDM carriers transmit through the communication channel simultaneously in parallel utilizing the maximum available bandwidth. At the receiver, applying a fast fourier transform (FFT) reverses this process.

In order for the received OFDM signal to be synchronized with the modulated one, OFDM symbols are sent in frames with a long symbol periods. Inter symbol interference (ISI) is not eliminated by long symbol periods. Therefore, guard intervals are introduced here. Simply, they are copies that are taken from the end of each symbol and added to its front end. This technique is known as the cyclic extension and it is applied to each symbol. This helps the receiver in fetching the information without loss, provided that the delay does not exceed the length of the guard interval [2]. Figure 2.1 shows the benefit of having cyclic prefix when the receiver gets a delayed version of the OFDM signal [2].

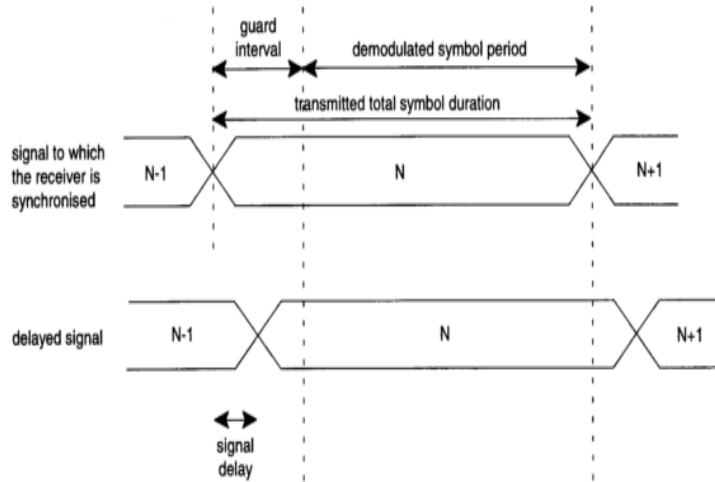

Figure 2.1 Benefit of the Guard bands [2]

2.3 Important OFDM Parameters

Subcarrier widths are the result of splitting the bandwidth w of the communication channel [45]. It is given by: $\Delta f = \frac{w}{N}$ where N indicates the number of subcarriers. The bandwidth of the channel is orthogonally divided as in Figure 2.2. Spectral efficiency is one advantage of this process because the peak of every signal overlaps with the other signals trough without causing any interference. Therefore, the system that meets this requirement is known as an OFDM system. In fact, it can be said that orthogonal carriers are the main assent of the OFDM.

Two signals are orthogonal to each other if they satisfy one condition. This condition requires the integral of two multiplied signals to be zero over a period of time. In fact, any two sinusoids are considered orthogonal provided that their frequencies

are integer multiples of the same frequency. This is expressed in equation 2.1.

$$\int_0^T \cos(2\pi nft) \cos(2\pi mft) dt = 0 \quad (n \neq m) \quad 2.1$$

Where n and m indicate two integers, T is the period of the integration, which is the period of one symbol [24]. It is convenient to set f to $\frac{1}{T}$ in order to get the most efficiency from the OFDM system [25].

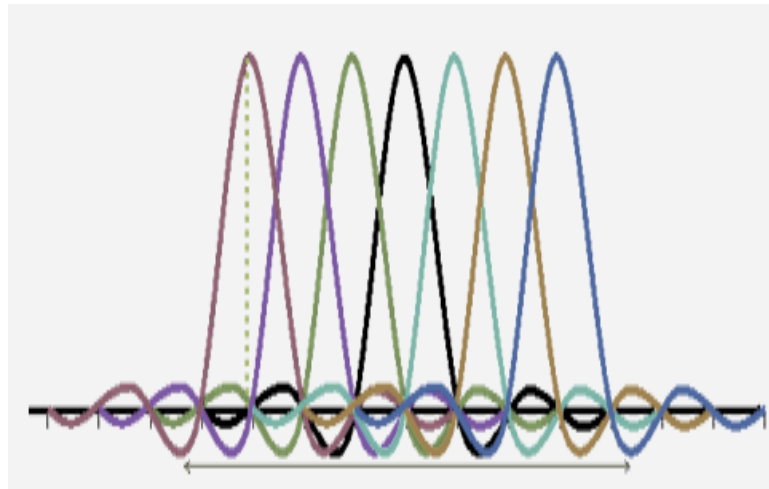

Figure 2.2 Spectrum of orthogonal OFDM sub channels [29]

Multicarrier signal can be calculated as in equation 2.2

$$s(t) = \sum_{m=-\infty}^{\infty} \left(\sum_{k=0}^{N-1} x_{k,m} \psi_k(t - mT_c) \right) \quad 2.2$$

In the equation above the k^{th} subcarrier is modulated by the $x_{k,m}$ symbol.

Two factors controls the number of subcarriers in any OFDM system. These two factors are the IFFT size and the bandwidth of the channel. IFFT size is decided by the relationship in equation 2.3[14]. ISI is reduced when the number of carriers increases.

$$\left(\text{number of subcarriers} \leq \frac{\text{IFFTsize}}{2} - 2\right)$$

2.3

OFDM modulation and demodulation are illustrated in figure 2.3. We clearly can see from the figure that subcarriers of a frequency $f_k = k/T_{sym}$ are modulated by the frequency domain symbol $X[k]$ for $N=6$ i.e. $k = 0,1,2 \dots 5$. The Orthogonal subcarriers are utilized to demodulate them in the receiver. Each OFDM symbol is composed of N symbols in a parallel form. Also, it is important to notice that the original length of the symbol $X[k]$ is extended from T_s to $T_s = NT_s$ as a result of transmitting N symbols simultaneously. Each symbol modulates one of the orthogonal carriers, which means having N subcarriers.

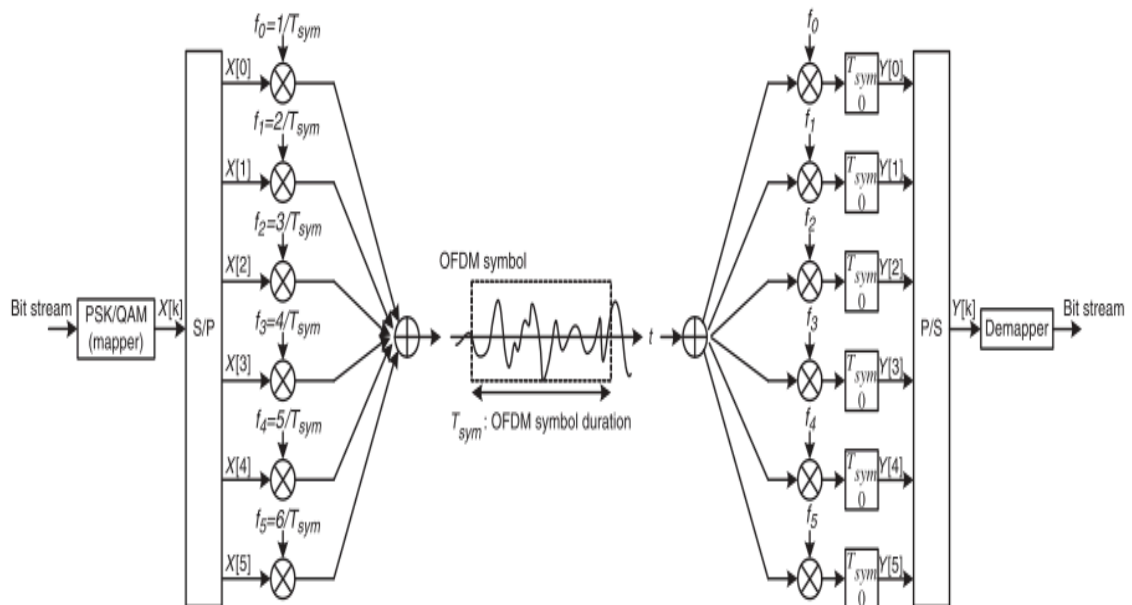

Figure 2.3 Block diagram of OFDM Modulation and demodulation [3]

2.4 OFDM Model

The general OFDM system is shown in figure 2.4. Blocks of data symbols are formed after reshaping data to parallel representation. Assuming that the number of blocks is N then the vector $X_m = (x_{0,m} \ x_{1,m} \ \dots \ x_{N-1,m})^T$ characterizes those symbols. Subcarriers are modulated after exposing them to IFFT as well as attaching guard bands of length N_{cp} . Equation 2.4 represents the m^{th} OFDM symbols.

$$S_m(n) = \begin{cases} \frac{1}{N} \sum_{k=0}^{N-1} x_{k,m} e^{\frac{j2\pi k(n-N_{cp})}{N}} & \text{for } n \in [0, N + N_{cp} - 1] \\ 0 & \text{otherwise} \end{cases} \quad 2.4$$

An envelope detector identifies the beginning and the end of every frame. Each frame is then demodulated to data. The received signal $r(n)$ is represented mathematically as in equation 2.5 [7]. It is obvious that this signal is the result of summing AWGN $n(n)$ and the convolution of the channel's impulse response $h(n)$.

$$r(n) = \sum_{\eta}^{n_{cp}-1} h(\eta) s(n - \eta) + n(n) \quad 2.5$$

We can imagine that the channel is constant for one OFDM symbol. This is possible by supposing that the fading is slow enough. In addition, we could assume in an ideal case that the transmission process is synchronized.

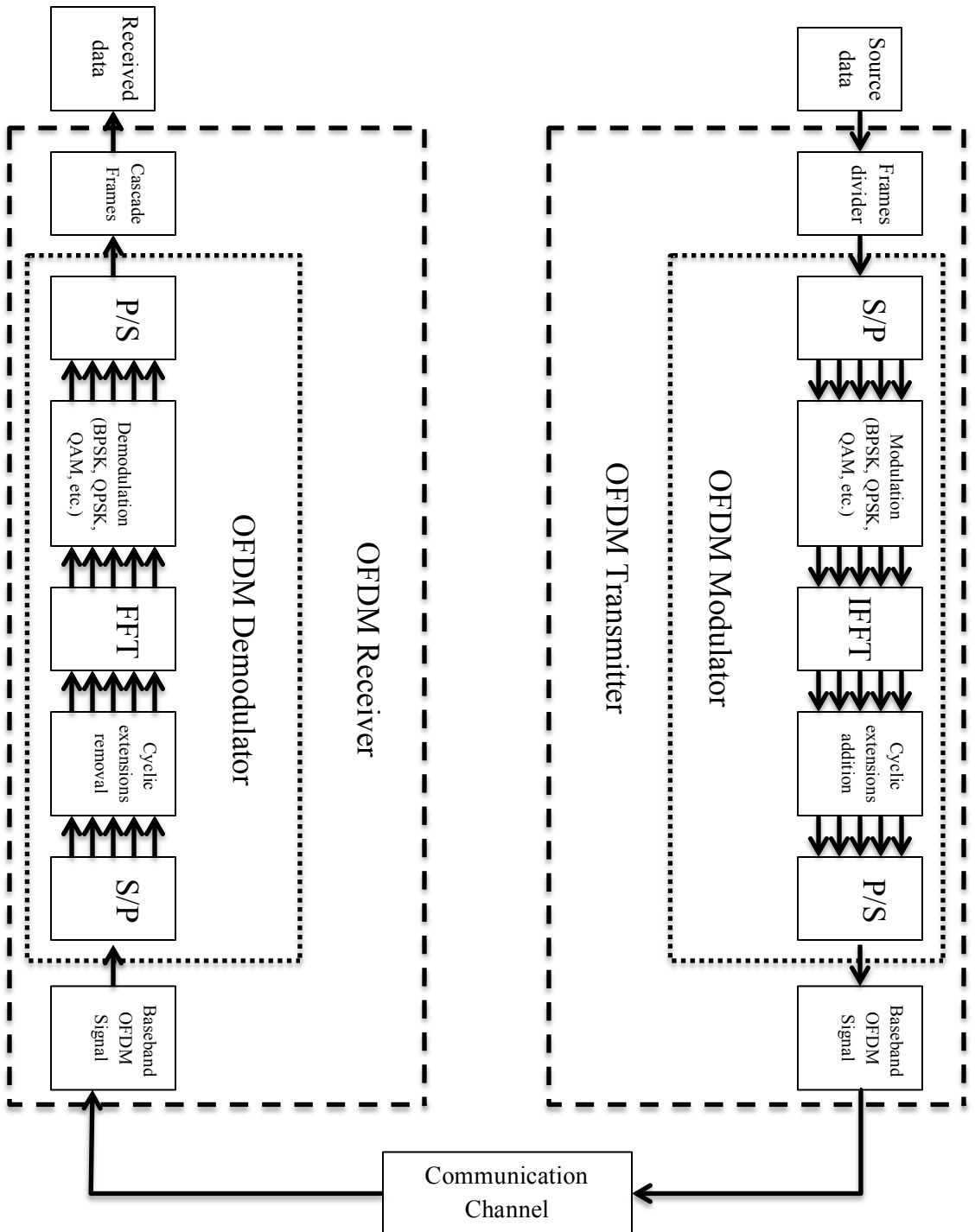

Figure 2.4 OFDM System Block Diagram

2.5 Advantages of OFDM

It is obvious that OFDM is getting popular in modern communication systems because of its numerous advantages [22]

2.5.1 Tolerance Towards Multi-path Delays

As mentioned before, the efficiency of OFDM to decrease ISI because of multi-path delay is increased after lengthening OFDM symbols by a factor of N (which represents the number of subcarrier). In fact, ISI can be completely eliminated provided that cyclic extensions with good design are used.

2.5.2 Robustness against Channel Distortion

It is almost impossible to have a frequency response of a channel with flat amplitude in single carrier communications. This leads to ISI and delay variation in the channel. For example, the twisted-pair working in single carrier telephone lines are used to handle calls with low frequency responses when transmitting high frequencies. Equalizers with a complexity that depend on the strength of the channel distortion are used in order to reduce channel distortion. However, an OFDM system has a flat amplitude response because of the narrow bandwidth of each subcarrier. In the case of high distortion, a very simple equalizer is used to easily correct distortions.

2.5.3 Capacity Transmission

OFDM systems are capable of transmitting in the highest possible capacity because of their tolerance towards channel fading and distortions. The technique used to make that achievable is called channel loading. Assuming that particular frequency range of subcarriers has fading notches, then it would be more convenient to alter the modulation only for this subcarrier in order to enhance its ability to reduce noise. This maximizes the overall capacity of the system as long as the notch does not change rapidly when compared to the OFDM symbol duration. However, it is very important to detect that notch by means of channel estimation. Also, we should have the data from channel estimation algorithms. Actually, there is no similar solution that can be applied in single carrier communications to minimize the effect of a fading notch and we can only depend on equalizers and error correction codes.

2.5.4 Effectiveness Against Impulse Noise

Impulse noise can be defined as the interference that results from natural phenomena such as lightning. It happens in communications that is using either wireless or twisted pair channels. Usually, symbol duration is much less than the length of the waveform of interference. In order to clarify that, we can imagine having a system of 10 Mbps that has $0.1 \mu\text{s}$ as its symbol duration. A burst error that cannot be reversed using conventional error correcting codes happens if the noise waveform is more than two microseconds.

Because OFDM symbol duration is longer than the symbol duration of single carrier systems, it is not affected very much by impulse noise. Therefore, it is possible that no single symbol error takes place in OFDM systems. As a result, OFDM systems' transceiver designs are much simple because there is no need to use the complicated error correcting codes to prevent errors caused by impulse noise.

2.5.5 Frequency Diversity

If someone is looking for frequency diversity, OFDM is the most appropriate technique to use. MC-CDMA, which is a mixture of OFDM and CDMA, makes frequency diversity available in the system.

2.6 Disadvantages of OFDM

Although OFDM has brought many great features to communication systems, it has some disadvantages. These drawbacks are being researched all over the world in order to make OFDM systems [22].

2.6.1 Peak to Average Power Ratio (PAPR)

High PAPR is considered to be one of the main disadvantages of OFDM. The reason behind that could be understood if every modulated subcarrier is seen as a complex signal at its own frequency. This is clear since OFDM signals are nothing but the addition of N complex random variables. Hence, PAPR is considered to be a transmitter issue. The transmitted waveform must contain all the peaks. Therefore, the power amplifier of the transmitter is required to have a wide linear range in order to prevent clipping of the

waveform to be transmitted. Such amplifiers are very expensive to build and consume a large amount of power [27][16][18].

2.6.2 Sensitivity to Frequency Errors

Frequency errors might cause degradation in the performance of an OFDM system. ICI causes the BER in the received signals that might be affected by the Doppler frequency shifts and carrier synchronization errors [6].

2.7 Applications of OFDM

Since the invention of OFDM in the last century, a lot of applications that utilize it have emerged especially in the last decade. An overview of some of the important applications is provided in this section [22].

2.7.1 Digital Audio Broadcasting (DAB)

AM and FM are considered to be old analog technologies that already have reached their limits. Therefore, they are now being replaced by DAB. Digital broadcasting is used all over Europe. The European Telecommunication Standards Institute (ETSI) approved it in 1995[8]. With DAB, several transmitters can deliver the same data to one receiver. This is due to the single frequency network in which it is designed to operate. In fact, it makes a good use of the available spectrum. Also, Multipath issues, that happen because of the number of transmitters and cause some delay in the reception process, are well handled by DAB if the correct guard bands are chosen.

2.7.2 Digital Video Broadcasting (DVB)

In 1997, the European Telecommunications Standards Institute (ETSI) approved DVB. It regulates transmitting digital video over terrestrial, cable and satellite. Some of the important parameters of DVB include:

- Two modes: 2k and 8k modes with 1705 and 6817 subcarriers respectively.
- QPSK, 16-QAM or 64-QAM are used to modulate the subcarriers.
- Coherence in the received signal is achieved using a pilot subcarrier that can give phases and reference amplitudes.
- A pilot subcarrier is mainly utilized with two-dimensional estimation.

2.7.3 Wireless LANs

OFDM is present in wireless LANs because the small amount of delay it has. Also, OFDM has a very high efficiency for indoor applications since the delay spread is less in this case. Directional antennas are usually used for outdoor environment especially if equal guards are used.

2.7.4 OFDMA

OFDM is applied in the multiple access technique known as OFDMA. The implementation of this technique is possible by assigning a smaller number of subcarriers to every user. Although there are some similarities between OFDMA and FDMA, the large guard bands that are used to avoid ICI are not used in OFDMA.

2.7.5 Fourth Generation 4G

4G is the acronym for the fourth generation of cell phone mobile communication networks. Since modern digital signal processing has greatly improved, OFDM has become very practical to implement. That is why it is now used in 4G wireless communications. 4G revolutionized Intelligent Transportation Systems (ITS) such as broadband communications to high speed moving receiver, video advertising, and broadband wireless internet [35].

Chapter Three: Communication Channel

The term channel denotes the medium connecting the transmitting and the receiving ends.

In practice, the medium of transmission could vary depending on the system [20]:

- 1) The link between two points in a circuit
- 2) The way of delivering an electrical or electromagnetic signal
- 3) Connecting a data source to a data sink.
- 4) A track that can be reached to a certain reading or writing station from a storage medium

Usually in wireless communication models, additive noise and random attenuation of the signal represent communication channels. The random attenuation is used to indicate the loss in signal as it reaches the receiver and the noise is used to manifest external interference. Communication systems could be:

- One way systems
- Two ways systems

3.1 Fading

In a wireless environment such as the one in figure 3.1, radio signals might arrive to the receiver by two or more paths in phenomenon known as multipath propagation. Multipath is caused by many factors such as Atmospheric ducting, ionosphere reflection and refraction. Phase shifting, destructive and Constructive interference are possible in a multipath environment [5]. This would result in Rayleigh Fading that affects the quality of the received signal after causing errors.

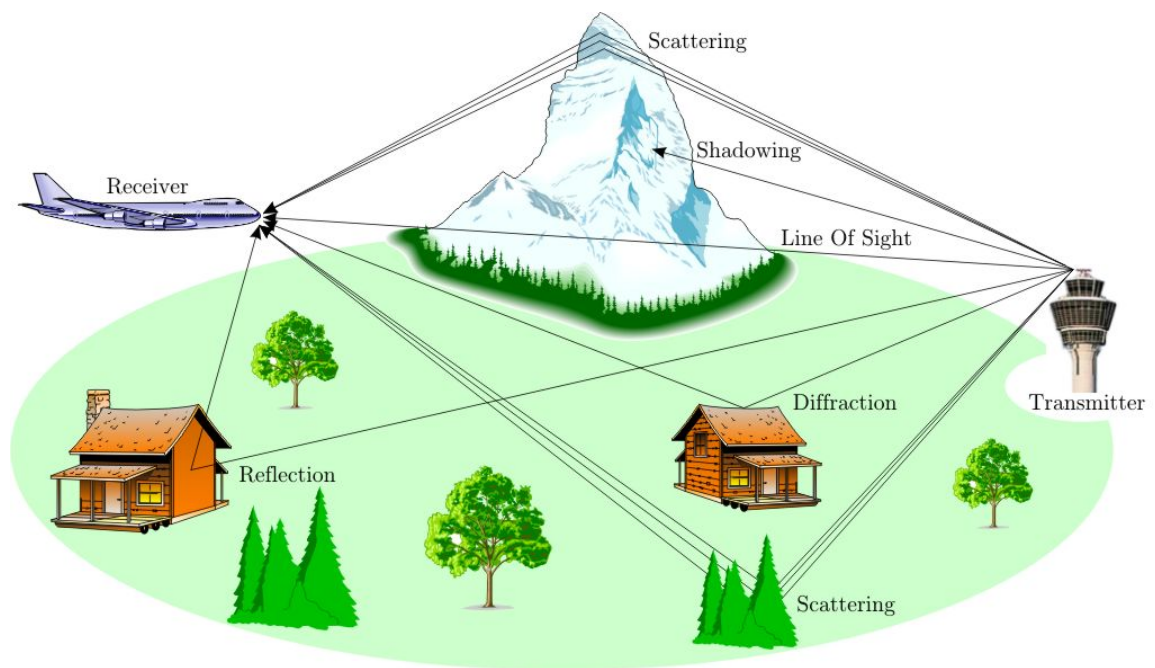

Figure 3.1 Multipath environment [19]

Fading is simply the result of the overlap in the received signal that occurs after receiving multiple copies of that signal at different times. The receiver in this case is dealing with signals that can have different amplitudes and phases as a result of the propagation time, the intensity distribution of the waves, and the bandwidth of the transmitted signal [23][33].

Fading can be divided into two main categories: large scale and small scale fading. The first usually happens as a result of objects around the propagation environment such as hills, mountains, etc. Small scale fading happens when no single line of sight (SOF) is available between both sides. This usually occurs when antennas are shorter than some of the objects around it. Small scale fading happens sometimes even if there is a line of sight because the reflection from other objects can lead to the receiving of signals with different waves that consist of amplitudes and phases distributed randomly.

The practical way to fight fading is to send more than one version of the signal and to combine them coherently at the receiver. This could be achieved by the use of multiple antennas. The easiest way to model fading is to multiply the signal with a random variable that represents a time dependent coefficient. This will result in a random signal to noise ratios SNRs.

The two types of fading are illustrated in figure 3.2. It is divided into two main categories based on delay spread and Doppler spread. Only small scale fading is considered in this research.

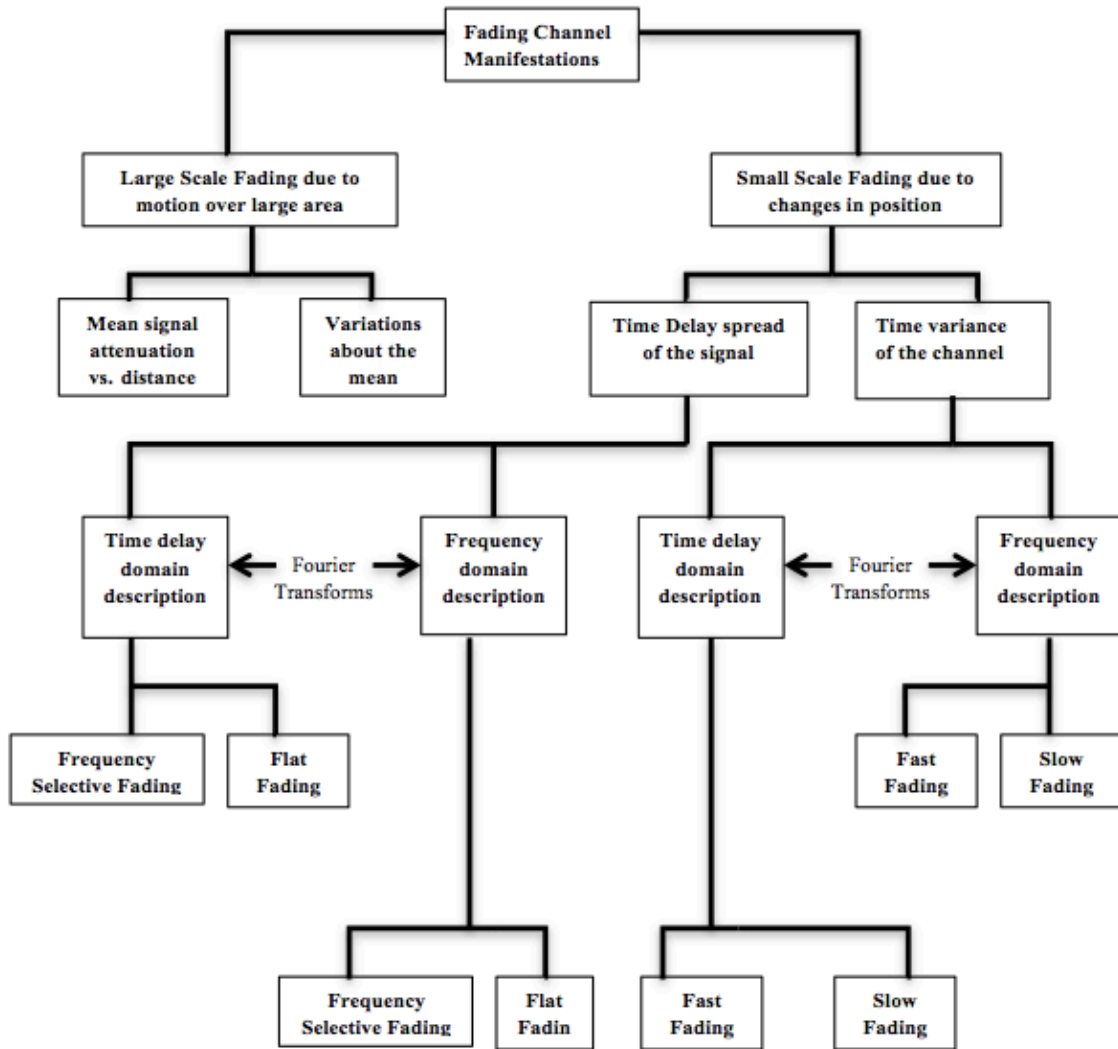

Figure 3.2 Fading Channel Manifestations [26]

3.2 Kinds of Small Scale Fading

Types of fading are controlled by the characteristic of the channel and the nature of the signal [36]. Factors like symbol period, bandwidth, and parameters of the channel such as Doppler spread, RMS and delay spread, control the quality of the communication channel. Four Kinds of fading could possibly caused by these factors:

- Slow fading
- Fast fading
- Flat fading
- Frequency selective fading

3.2.1 Fading from Multipath Time Delay Spread

Delay spread that is depicted in figure 3.3 consists of two categories [23]:

1) Flat Fading:

Flat fading is the most common types of fading. It happens when the gain and the bandwidth of the channel are larger than the signal's bandwidth. The power of the transmitted signal is the main difference because it changes according to the variation in the gain of the multipath channel. The spectrum, however, does not vary in this case.

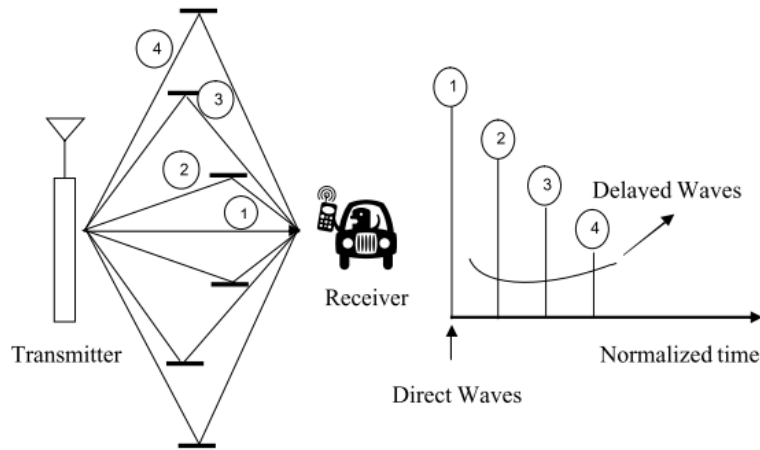

Figure 3.3 Delay Spread [20]

2) Frequency Selective Fading

In this type of fading, the gain is constant and it has a linear phase response. However, the signal has a bandwidth that is bigger than the channel's bandwidth. In this situation, the signal is distorted due to the multiple copies of the signal with different amplitude and a time delay. For example, this kind of fading in wireless communication happens because of the time dispersion that happens to the transmitted signal [46].

3.2.2 Fading from Doppler Spread

Both slow fading and fast fading are the result of Doppler spread. The speed of the receiver decides if the signal experiences slow or fast fading. There are some characteristics for slow and fast fading.

1) Slow Fading

This type of fading occurs when the symbol duration is more than that of the coherence. The signal changes slower than the channel. The transmitted signal varies faster than the impulse response of the channel.

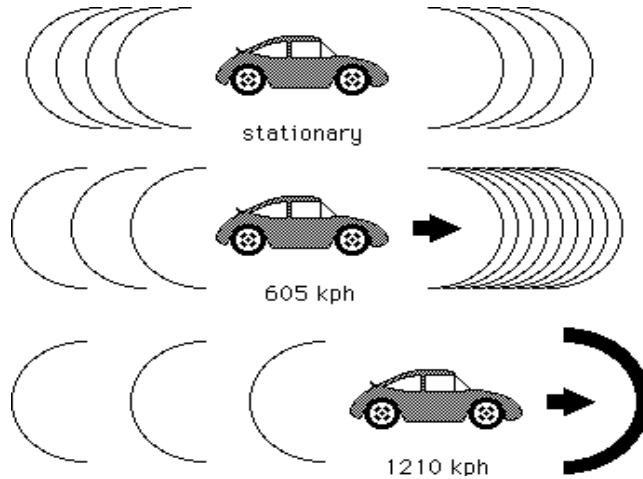

Figure 3.4 Doppler spread [21]

2) Fast Fading

The channel experiences fast fading when its impulse response varies too fast during the symbol period. In other words, the duration of the symbol that is being transmitted is more than the channel's coherence time.

3.3 Factors affecting Small Scale fading:

1) Velocity of the receiver

This factor leads to Doppler shift when the receiver is not stable i.e. moving. Doppler shift is either positive or negative. The positive Doppler shift happens when the receiver

moves toward the transmitter while the negative Doppler shift happens when the receiver moves away from the transmitter.

2) Velocity of objects within the channel

Sometimes things in the wireless environment are moving. If the velocity of that motion is more than the velocity of the receiver, small scale fading is caused. It can be ignored when the velocity of these objects is less than that of the receiver.

3) Multipath propagation

The energy of signal is wasted to phase, amplitude, and time when signal propagates in more than one path. In situations like this, more than one copy of that signal gets to the receiving end. The time needed for the signal to get to the receiver might be increased if it propagates in two or more paths.

4) Bandwidth of the channel

In the case where the bandwidth of the communication channel is less than the bandwidth of the signal, it will experience distortion. This issue is not a problem in a local network because the distortion is very little. Flatness of the transfer function of the channel is the only condition required in order to have a coherent bandwidth. The channel transfer function is flat when the phase response is linear and the gain remains the same [10].

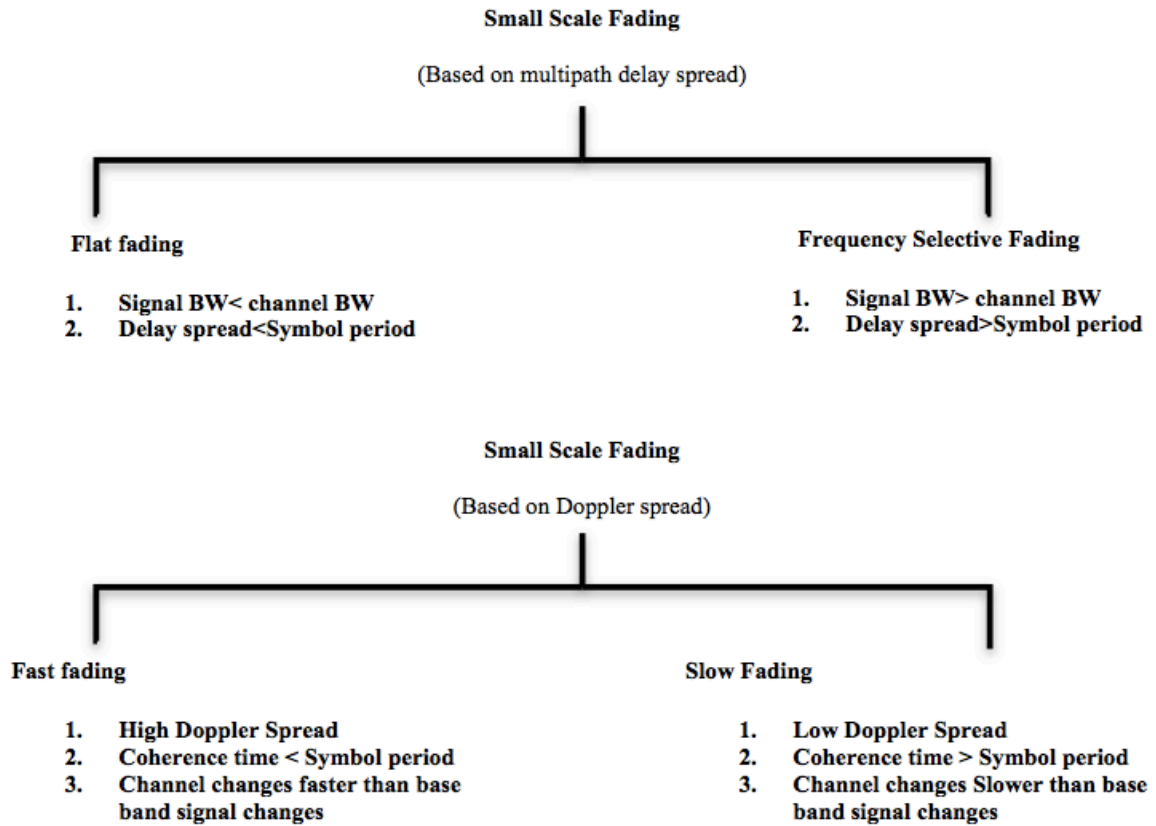

Figure 3.5 Small Scale Fading based on Multipath and Doppler Spread

3.4 Communication Channel Model

In this section, the model of the wireless communication channel is considered as an impulse response. The ease of analyzing and comparing the performance of different systems, each with a certain channel condition, is the reason impulse response is used.

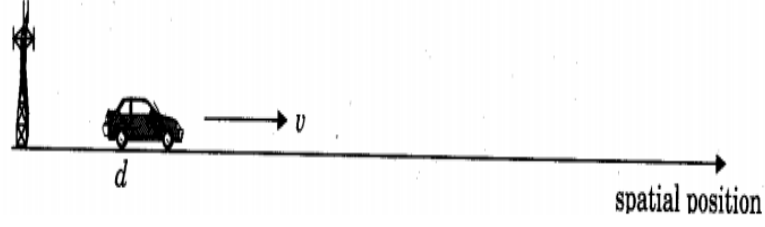

Figure 3.6 Moving Receivers [30]

Time varying impulse response is used to model the filtering characteristics of the channel. As in figure 3.5, the motion of the receiver is the only variable that affects time. The received signal $y(d, t)$ is given by equation 3.1

$$y(d, t) = \int_{-\infty}^t x(\tau)h(d, t - \tau)d(\tau) \quad 3.1$$

where $h(d, t)$ is the channel's impulse response and $x(t)$ is the signal transmitted.

Knowing that the position of the receiver is $d = vt$ and knowing that v is just a constant, d in equation 3.1 could be replaced with vt as in equation 3.2. As a result, mobile radio channels are expressed as a linear time varying.

$$y(vt, t) = \int_{-\infty}^t x(\tau)h(vt, t - \tau)d(\tau) \quad 3.2$$

In a multipath channel, copies of the transmitted signal that are attenuated, time and phase shifted are received. Equation 3.3 represents the impulse response of the baseband channel in this case,

$$h_b(t, \tau) = \sum_{i=0}^{N-1} a_i(t, \tau)e^{j(2\pi f_c \tau_i(t) + \phi_i(t, \tau))} \delta(\tau - \tau_i(t)) \quad 3.3$$

where $a_i(t, \tau)$ represents amplitudes and $\tau_i(t)$ represents delays. $\theta_i(t, \tau) = 2\pi f_c \tau_i(t) +$

$\varphi_i(t, \tau)$ is the phase shift of the i th multipath component.

In case of time invariant channel, equation 3.4 represents the impulse response of the channel. Time invariant in this case means the time delay is present in every multipath component of the channel impulse response.

$$h_b(\tau) = \sum_{i=0}^{N-1} a_i(t, \tau) e^{[j\theta_i(t, \tau)]} \delta(\tau - \tau_i(t)) \quad 3.4$$

3.4.1 Delay Spread Parameters

A power delay profile is utilized to get the channel's parameters that consist of a multipath propagating environment. The average of the instantaneous power delay profile is used to find out the average small-scale power delay. Usually $\frac{1}{4}$ of the wavelength is used as the spatial separation of sampling is. Also, the motion of the receiver does not exceed 6m and 2m for sampling in outdoor and indoor environments respectively.

The desparation parameters of multipath channel include RMS delay spread, means excess delay, and excess delay spread. These parameters can be found via the power delay profile. For wide band multipath channels, the mean excess delay $\bar{\tau}$ given by equation 3.5 and RMS delay in equation 3.6 control the time dispersive properties.

$$\bar{\tau} = \frac{\sum_k a_k^2 \tau_k}{\sum_k a_k^2} = \frac{\sum_k P(\tau_k) \tau_k}{\sum_k P(\tau_k)} \quad 3.5$$

$$\sigma_\tau = \sqrt{\bar{\tau}^2 - (\bar{\tau})^2} \quad 3.$$

The impulse response of a wireless channel is used to describe it. All the important data needed to simulate and analyze any kind of mobile radio channel could be provided by the impulse response of the channel. In fact, linear filters that have a time varying impulse response could be used to model that channel. The movement of the receiving side causes time variations in this case. Addition of all amplitudes and delayed copies of the transmitted signals waves at any moment is used to implement that filter.

In any wireless environment, the symbol period and the RMS delay spread of the channel relationships govern the severances of the delay spread in the channel. The power delay profile is usually measured experimentally. Also, the channel environment has its effects. Therefore, a functional form of the profile is assumed. This form could have varied parameters for the purpose of simulation to get results that could be applied to a broad spectrum [4]. Figures 3.7 and 3.8 shows the Gaussian power delay profile and the exponential power delay profile that are given by equation 3.7 and 3.8 receptively.

$$P_e = \begin{cases} \frac{1}{s} e^{(-\frac{\tau}{s})}, & \tau \geq 0 \\ 0 & \textit{otherwise} \end{cases} \quad 3.7$$

$$P_g(\tau) = \begin{cases} \frac{1}{\sqrt{2\pi}S} e^{(-\frac{(\tau-\bar{\tau})^2}{2S^2})}, & \tau \geq 0 \\ 0 & \textit{otherwise} \end{cases} \quad 3.8$$

S represents RMS delay spread and $\bar{\tau}$ indicates average delay.

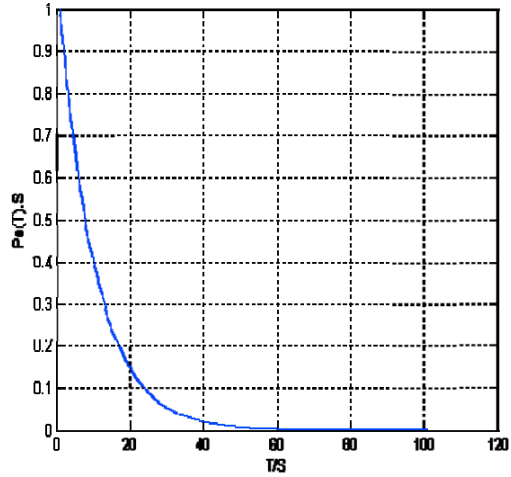

Figure 3.7 Normalized exponential power delay profile [13]

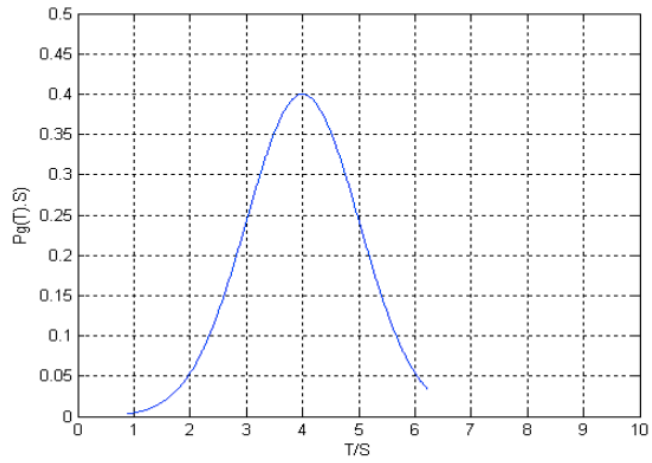

Figure 3.8 Normalized Gaussian Power delay profile [13]

3.4.2 Doppler Spread Parameters

A Doppler spread is considered when the receiver is moving through the path d with a speed v . $d \cos \theta$ is the length of the distance from the source s . The phase difference due to the change in path lengths in the received signal is given by equation 3.9.

$$\Delta\varphi = \frac{2\pi\Delta l}{\lambda} = \frac{2\pi\Delta t}{\lambda} \cos\theta \quad 3.9$$

Equation 3.10 gives the Doppler frequency, which describes the relation among the speed of the receiver, the Doppler shift, and the angle with the directions of the wave movement and its arrival.

$$f_d = \frac{1}{2\pi} * \frac{\Delta\varphi}{\Delta t} = \frac{v}{\lambda} \cos\theta \quad 3.10$$

Doppler shift is frequency dependent. Therefore, in a multipath communication channel, Doppler shift is different for each copy of the signal propagating along that path. The signal at the receiver is the result of adding those copies. Therefore, the spectrum of the transmitted signal is much less than the spectrum of the signal that reaches the receiver. As a result, channel variations are controlled by how much Doppler spread the signal is exposed to when transmitted through the channel.

In a multipath environment, power spectral density of single frequency sinusoid is the Doppler spectrum. The power density function (PDF) is the impulse response that has the frequency of the carrier when the channel is stationary.

A channel with a moving receiver of velocity v and received signal power with a Doppler spectrum in figure 3.9 is given by equation 3.11.

$$S(f) = \frac{k}{\sqrt{1 - \left(\frac{f - f_c}{f_{max}}\right)^2}} \quad 3.11$$

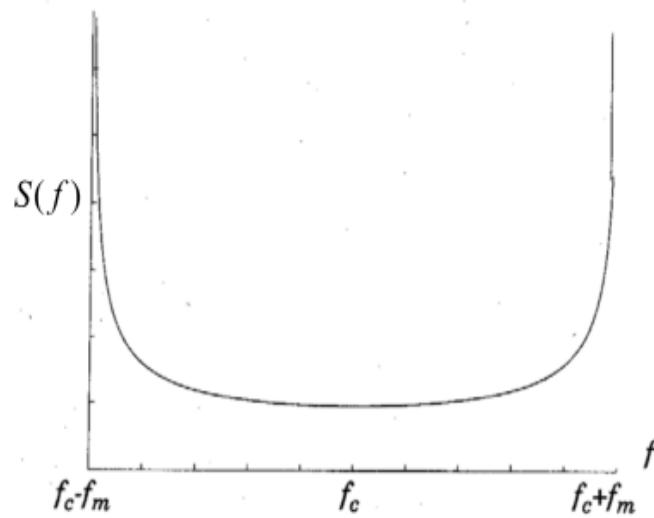

Figure 3.9 Doppler Spectrums [30]

The rate of channel variations is considered to be the top Doppler shift f_{max} . It is also identified as the bandwidth of the Doppler spectrum. Fast fading happens when that Doppler bandwidth is big in comparison to the bandwidth of the signal because channel changes are fast in comparison to the changes of the signal. Otherwise, it is known as slowfading.

3.5 Rayleigh Distribution

Characteristics of a multipath channel over radio signal can be statistically modeled using Rayleigh fading model. Power of the signal varies in a random fashion or fades according to Rayleigh distribution. It assumes that no direct path between transmitter and receiver exists; the signal can propagate through more than one path before getting to the receiver. The PDF of Rayleigh distribution is given by equation 3.11. It is simply the envelope that results from the summation of the quadrature Gaussian noise and the in-phase noise. Fading is complex and has zero mean Gaussian process. The envelope of fading follows the Rayleigh distribution pattern because the in-phase and quadrature components are complex.

$$p(r) = \begin{cases} \frac{r}{\sigma^2} e^{-\frac{r^2}{2\sigma^2}} & 0 \leq r < \infty \\ 0 & r < 0 \end{cases} \quad 3.11$$

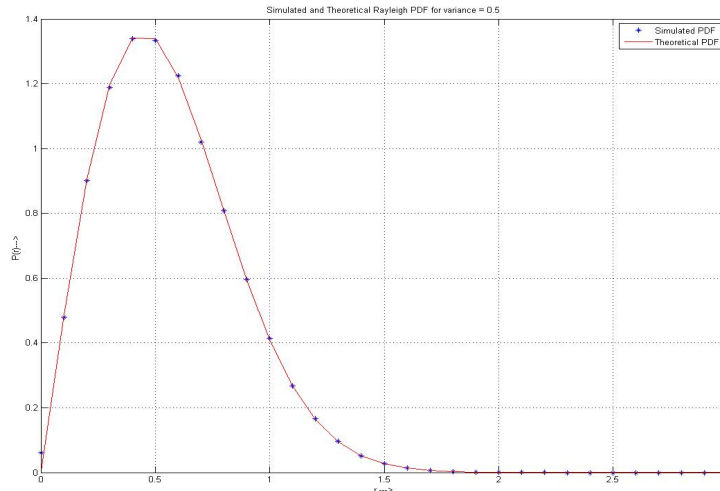

Figure 3.11 PDF of Rayleigh Distribution [8]

3.6 Multipath Fading Models

The statistical nature of a wireless communication channel is analyzed with the help of a number of models. One of the first models that have been proposed was by Ossana [12]. It uses waves that reflect from buildings at different locations but it was not suitable for use in urban areas with crowded buildings. This is because there has to be a direct line of sight path that may not exist in cities. Fortunately, several models have been suggested later to model wireless channel communications. The following list includes a number of these models:

- 1) Two ray Rayleigh fading model
- 2) Simulation of models
- 3) Saleh and Valenzuela indoor statistical model
- 4) Clark's model for flat fading
- 5) SIRCIM and SMRCIM indoor and outdoor statistical model.

Clark's model for flat fading is a model that is widely used. Therefore, it has been used in conducting this research.

3.6.1 Clarke's Model

Scattering principle is employed by Clarke's model to discover the statistical properties of the electromagnetic fields of the received signal. The main assumption of this model is a stationary transmitter with a vertical polarized antenna. The other assumption for the incident field antenna is that it may have N normalized plane waves with random carrier phases and random angles of arrival. The scattered components that

arrive to the receiver from a short distance usually go through the same attenuation because there is no direct path between the transmitting and the receiving sides.

For flat fading, a moving receiver is assumed. For the m_{th} wave that has arriving angle α_m with respect to the x-axis as shown in figure 3.12, the Doppler shift is given by equation 3.13.

$$f_m = \frac{v}{\lambda} \cos \alpha_m \quad 3.13$$

Where, λ is the wavelength of incident wave.

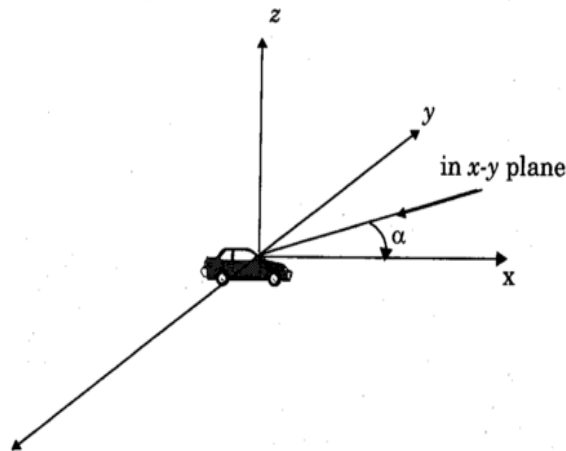

Figure 3.12 Received wave with angel of arrival α [30]

The spectrum is limited by $\pm f_m$ with a center frequency equal to the carrier frequency f_c . Every received wave in this case has a different carrier frequency with a small shift from the center frequency. The power spectral density of the output is given by equation 3.14. It is clear from that equation that the PDF is zero when $|f - f_c| > f_m$.

$$S(f) = \frac{A[q(\alpha)G(\alpha)+(-\alpha)G(-\alpha)]}{f_n \sqrt{1-\left(\frac{f-f_c}{f_m}\right)^2}} \quad 3.14$$

For example if we assume that there is a vertical $\frac{\lambda}{4}$ antenna, $G(\alpha) = 1.5$ and $p(\alpha) = \frac{1}{2\pi}$ over 0 to 180° , the output spectrum becomes as given by equation 3.15.

$$S(f) = \frac{1.5}{\pi f_m \sqrt{1-\left(\frac{f-f_c}{f_m}\right)^2}} \quad 3.15$$

PDF of Doppler components arriving between 0 and π are infinite. However, the probability that one component reaches the receiver within these angles is zero because α is uniformly distributed.

The simulator of frequency domain Rayleigh fading implementation is shown in figure 3.13. In order to simulate this model, in-phase and quadrature modulation are used. Therefore, in-phase and quadrature fading components are generated from two independent Gaussian low pass noise sources. Hence, orthogonal in-phase and quadrature components must be achieved in order to get each Gaussian source, which is the summation of those two components. IFFT is used at the last phase of the simulator for the purpose of shaping a random signal.

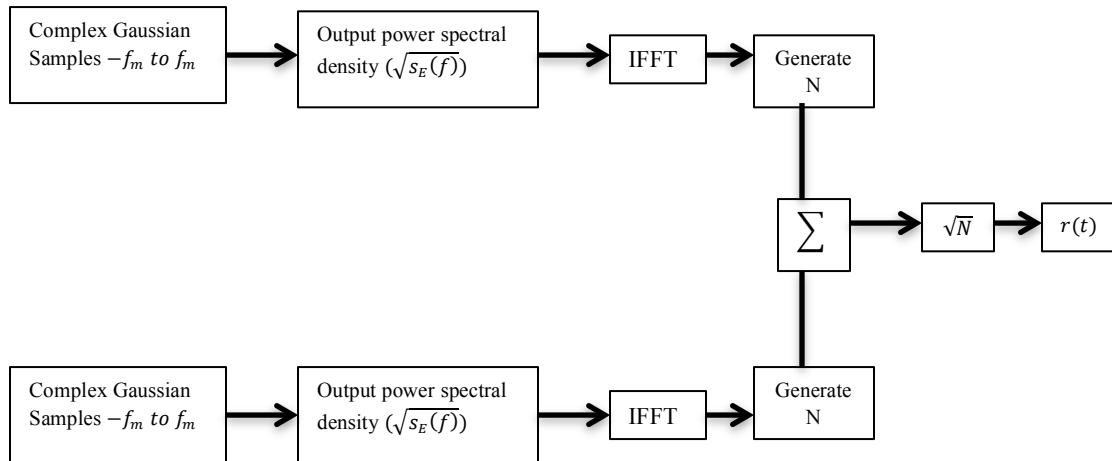

Figure 3.13 Rayleigh fading implementation

There are a number of steps that should be followed in order to implement the simulator in figure 3.13 [12]:

- Determine the number of points in frequency domain N that describes the square root of PDF $\sqrt{S_{E_z}(f)}$. The max Doppler frequency shift f_m should be specified as well
- Find out the time duration of the fading waveform that is given by $T = \frac{1}{\Delta f}$
- Create complex Gaussian random variables for each $\frac{N}{2}$ positive frequency components
- Conjugate positive frequencies in order to find the negative ones
- Multiply the in-phase and quadrature components by fading spectrum $\sqrt{S_{E_z}(f)}$
- Apply IFFT on the in-phase and quadrature components in order to obtain two N times series. Sum the squares of each signal point

- Take the square root of the summation done in the previous step in order to obtain the N Pnt time series with the Doppler spread and the time correlation for the Rayleigh fading.

Several Rayleigh fading simulators are used to implement Frequency selective fading, each with different variables gains and time shifts.

Chapter Four: Simulation Results

We have collected data from OFDM communication system outputs using MATLAB simulations based on the discussion in Chapters 2 and 3. To analyze its performance over wireless fading channels, the JPG image in figure 4.1 was used as the test signal to examine the performance of the system. The OFDM system simulated is based on the model illustrated in chapter 2 and fading channels were implemented according to Clarke's model.



Figure 4.1 Test Image

4.1 Trial of the OFDM Simulation

Parameters in table 4.1 were used in order to try the model shown in chapter 2 with different modulation schemes for AWGN Channel. Four kinds of modulation schemes were used to transmit a random signal. The modulation scheme was chosen based on BER run times of our program. Run time measurements for these trailers are shown in figure 4.2. It is easier to tell the difference in efficiency between all M- PSK based modulations. It is clear that the run time of the MATLAB program is less with BPSK than the other orders of PSK modulations.

Parameters	Values
Source signal	Random
IFFT size	1024
Number of Carriers	200
SNR	0-12

Table 4.1 Parameters for BER/SNR Test

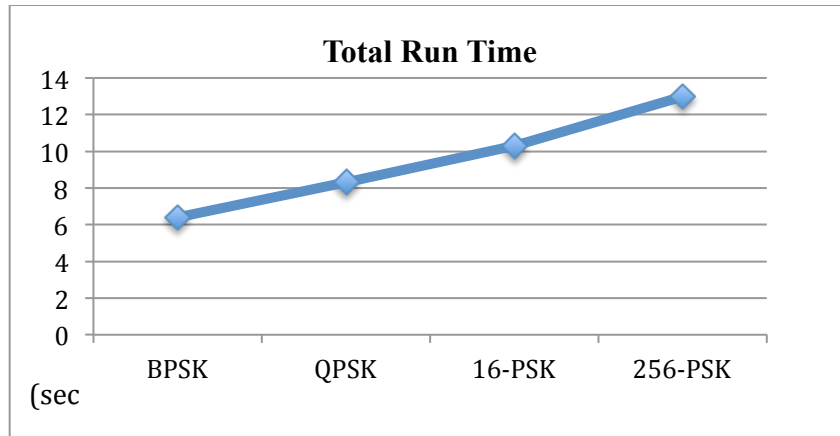

Figure 4.2 Program Run Time

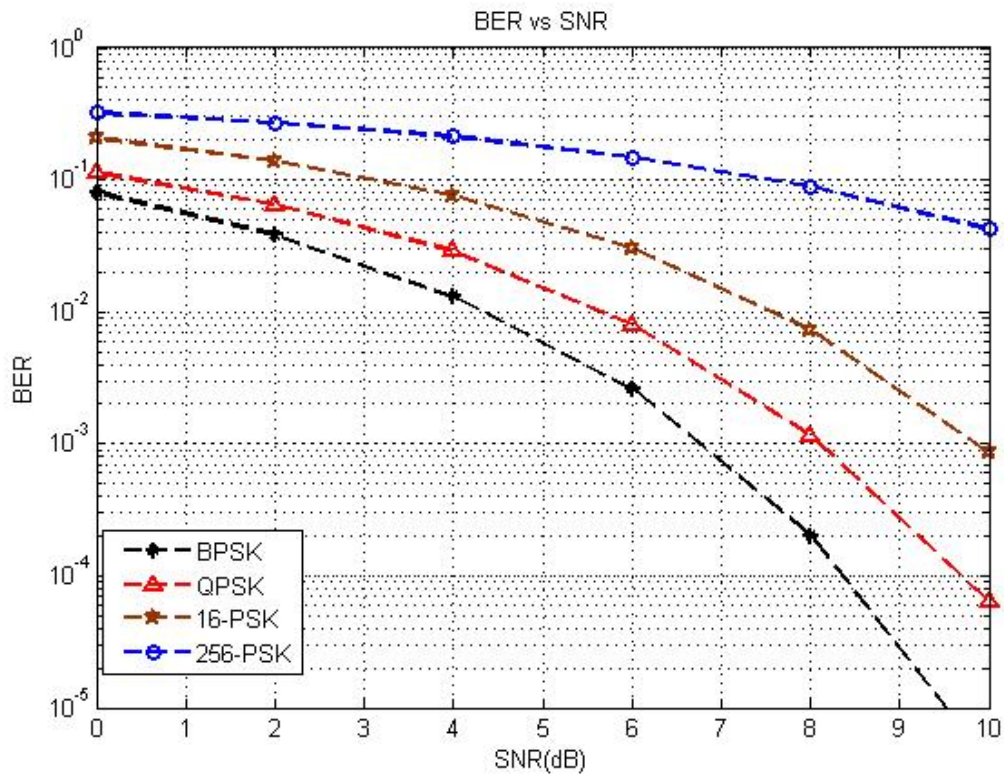

Figure 4.3 BER vs. SNR

The relationship between BER and SNR using different M-PSK modulations is shown in figure 4.3. It is obvious that BER increases at higher orders of M-PSK. It is also important to notice that BER rates are inversely proportional to the values of SNRs. Also, Figure 4.4 displays the difference in BER for the four types of M-PSK modulations. SNR used to measure BERs time is fixed at 6 dB.

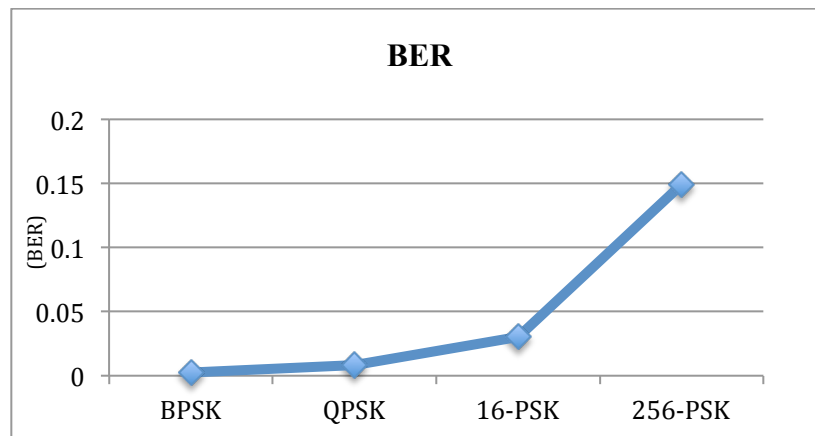
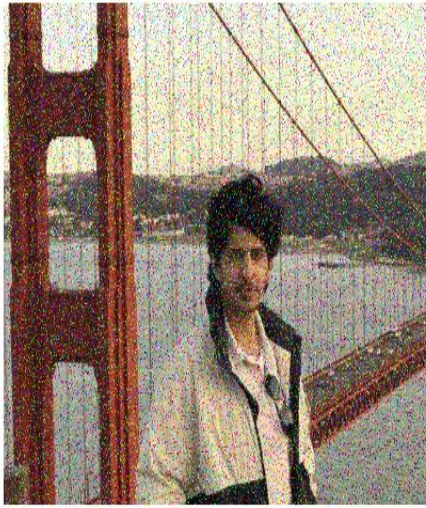

Figure 4.4 BER vs. M-PSK

According to results shown in this section, BPSK modulation is used in our simulation.

4.2 Transmission Over AWGN Channel

In this part of the simulation, AWGN channel is the medium of transmission. Simulation is repeated four times with different SNRs as shown in figure 4.5. Received image shows better qualities at higher SNRs, which is proved with BER and PSNR curves in figure 4.6. At higher SNR, BER decreases while PSNR increases. This indicates that the quality of the received signal is enhanced at higher SNRs.



0dB



4dB



8dB



12dB

Figure 4.5 Image sent Over AWGN Channel with Different SNRs

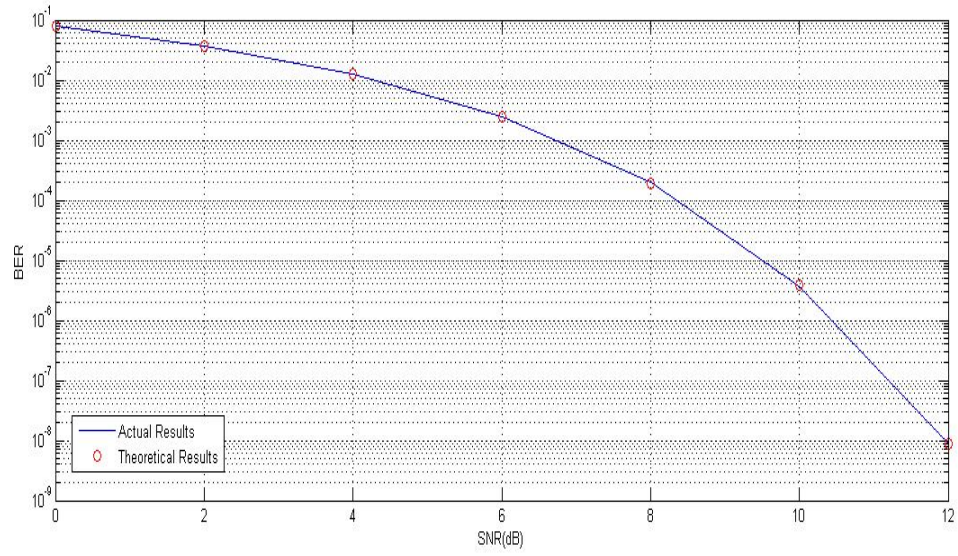

Figure 4.6 (a) BER over AWGN Channel

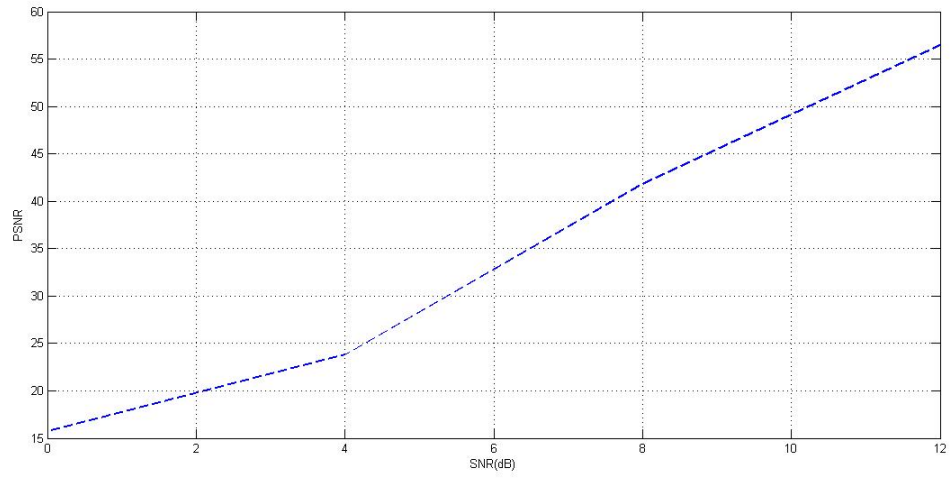

Figure 4.6 (b) PSNR over AWGN Channel

4.3 Transmission over Multipath Fading Channels

Small scale fading usually occurs due to the lack of single line of sight (SOF) between both sides. This usually happens when antennas are shorter than some of the objects around it. Small scale fading happens sometimes even if there is a line of sight but the reflection from other objects lead to the receiving of signals with different waves that consist of amplitudes and phases distributed randomly.

Clarke's model illustrated in chapter 3 is used to study the performance of OFDM over fading channels. Since mobility of the receiver is assumed, a slow receiver with a speed of 3 miles/hour and a fast receiver with a speed of 100 miles/hour were used in the simulation of flat and frequency selective fading.

4.3.1 Flat Fading Channels

Flat fading is the most common types of fading. It happens when the gain and the bandwidth of the channel are larger than the bandwidth of the signal. The power of the transmitted signal is the main difference in this case because it changes according to the variation in the gain of the multipath channel.

Flat fading channels are implemented using Clarke's Model. The simulation was carried with 3 miles/hour and 100 miles/hour as the speed of the receiver. The first speed is devoted for simulating Doppler spread while the second is used to create large Doppler spread. The process is repeated 4 different times for each of flat slow and flat fast fading and the outputs are shown in Figures 4.7 and 4.9 respectively. BERs and PSNRs over flat slow and flat fast fading are shown in shown in figures 4.8 and 4.10 respectively.



0dB

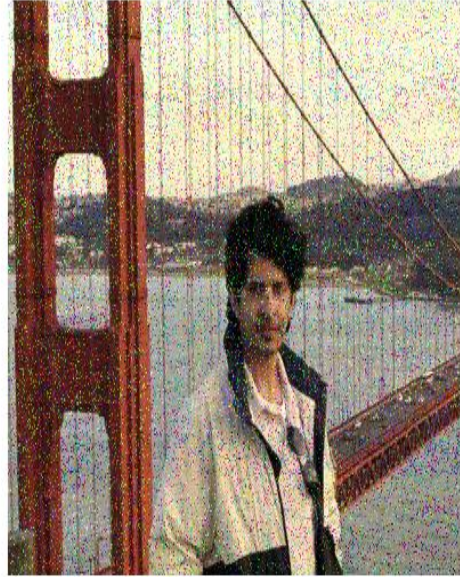

4dB



8dB



12dB

Figure 4.7 Image sent Over Flat Slow Fading Channel with Different SNRs

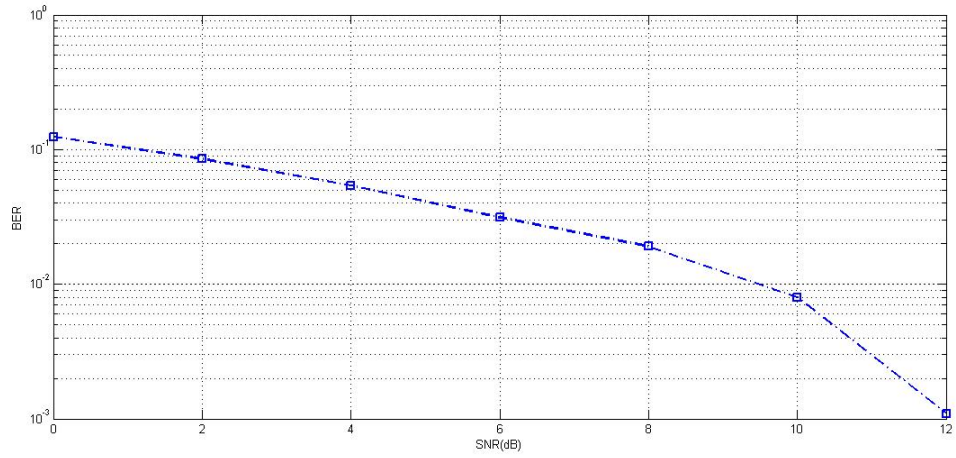

Figures 4.8 (a) BER over Flat Slow Fading

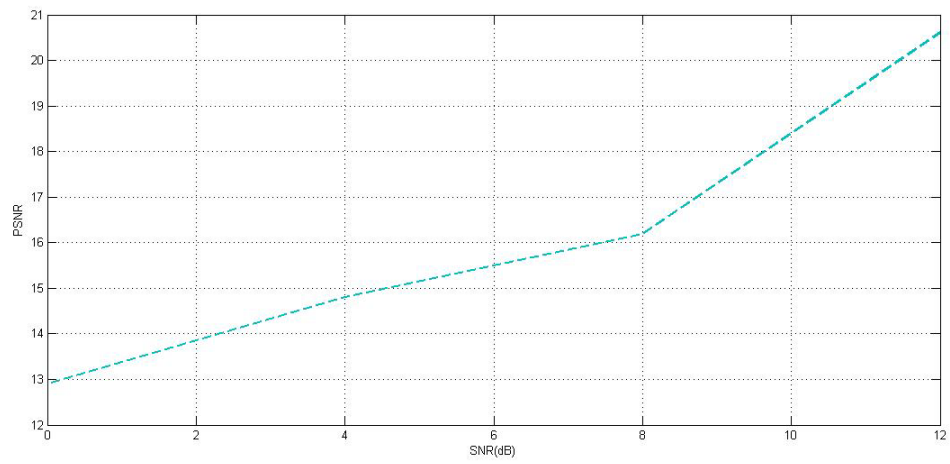

Figures 4.8 (b) PSNR over Flat Slow Fading

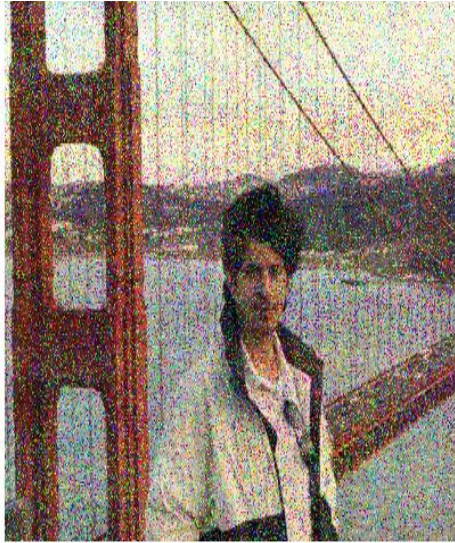

0dB

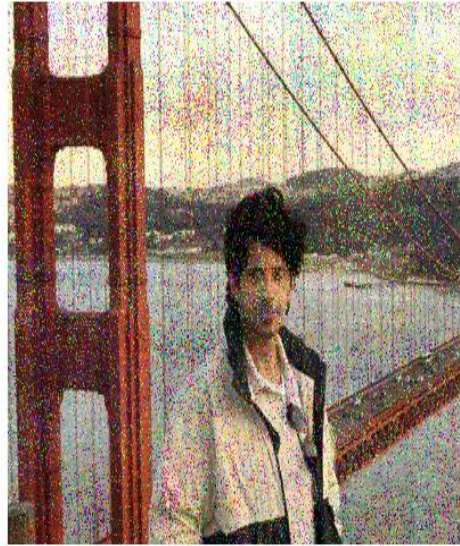

4dB



8dB



12dB

Figure 4.9 Image sent Over Flat Fast Fading Channel with Different SNRs

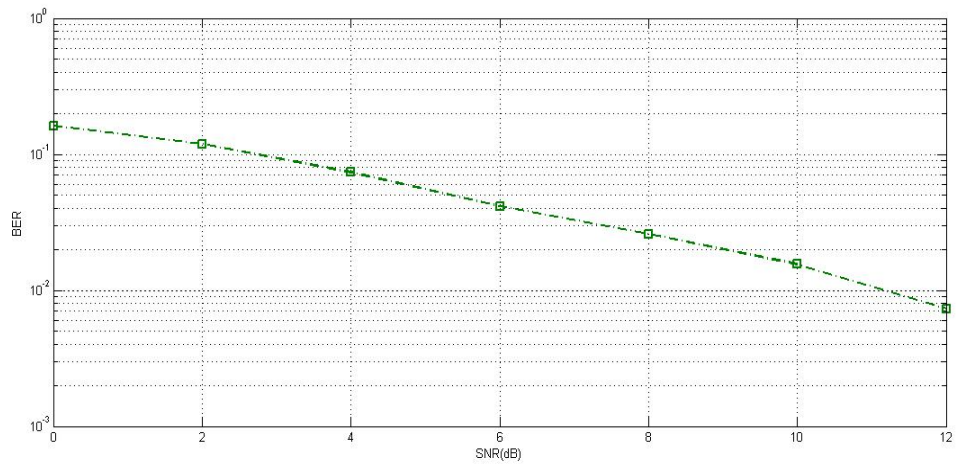

Figures 4.10 (a) BER over Flat Fast Fading

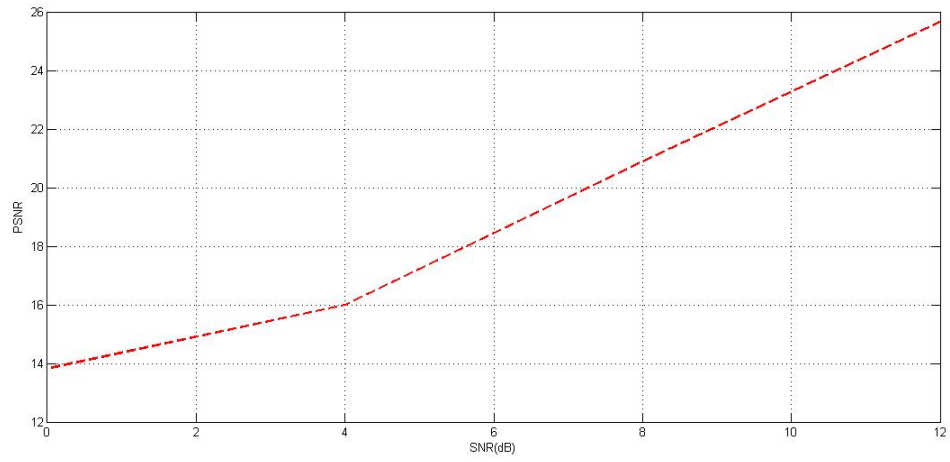

Figures 4.10 (b) PSNR over Flat Slow Fading

4.3.2 Frequency Selective Fading Channels

In this type of fading, the gain is constant and it has linear phase response. However, the bandwidth of the signal is bigger than the channel's bandwidth. In this case, the signal is distorted because of the multiple copies of the signal with different amplitude and a time delay. This kind of fading in wireless communication happens because of the time dispersion that happens to the transmitted signal.

More than one Clark's models are applied in order to get the effect of frequency selective fading. The models are applied to multiple copies of the signal with different delay. Therefore, the copies reach the receiver in 4 paths with 0, 4, 8, and 16 delays. The same speeds are set again for the receiver to simulate frequency selective slow fading with 3 mile/hour the received signals are shown in figure 4.11. Frequency selective fast fading signals with 100 mile/hour are shown in figure 4.13. BER and PSNR of transmission over frequency selective slow/fast fading are shown in figures 4.12 and 4.13 respectively.

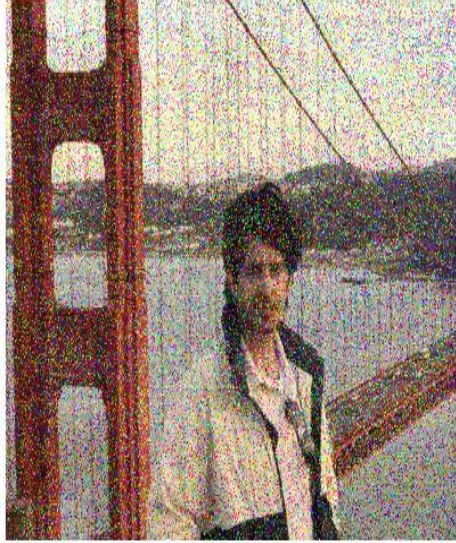

0dB

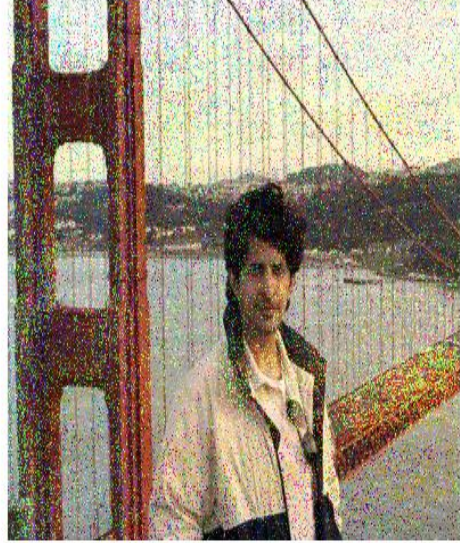

4dB



8dB



12dB

Figure 4.11 Image sent Over Frequency Selective Slow Fading Channel with Different SNRs

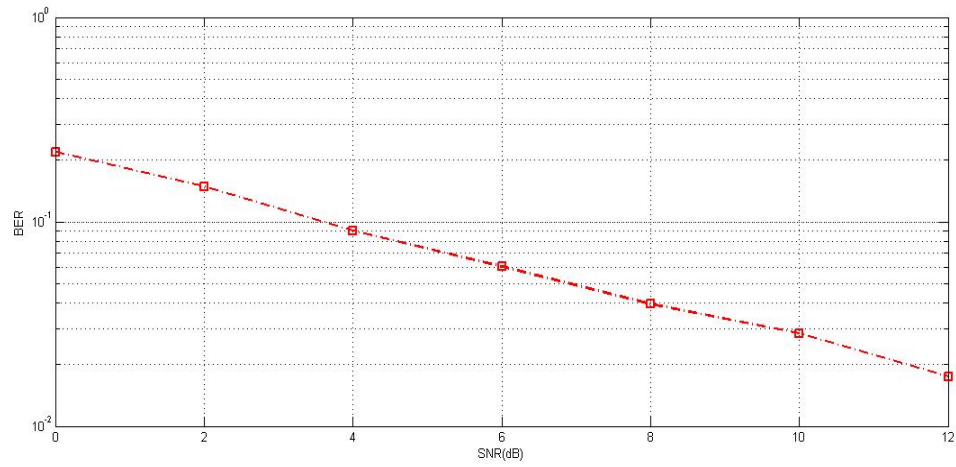

Figures 4.12 (a) BER over Frequency Selective Slow Fading

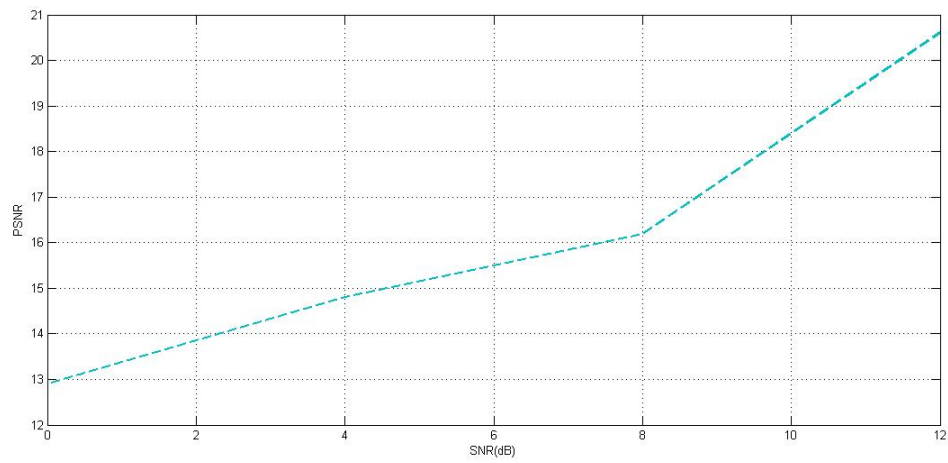

Figures 4.12 (b) PSNR over Frequency Selective Slow Fading



0dB



4dB

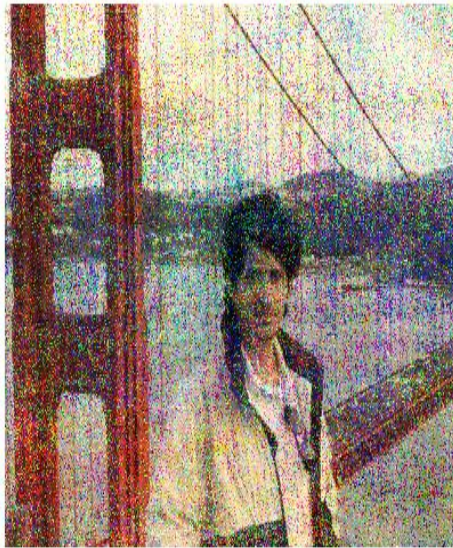

8dB



12dB

Figure 4.13 Image sent Over Frequency Selective Fast Fading Channel with Different SNRs

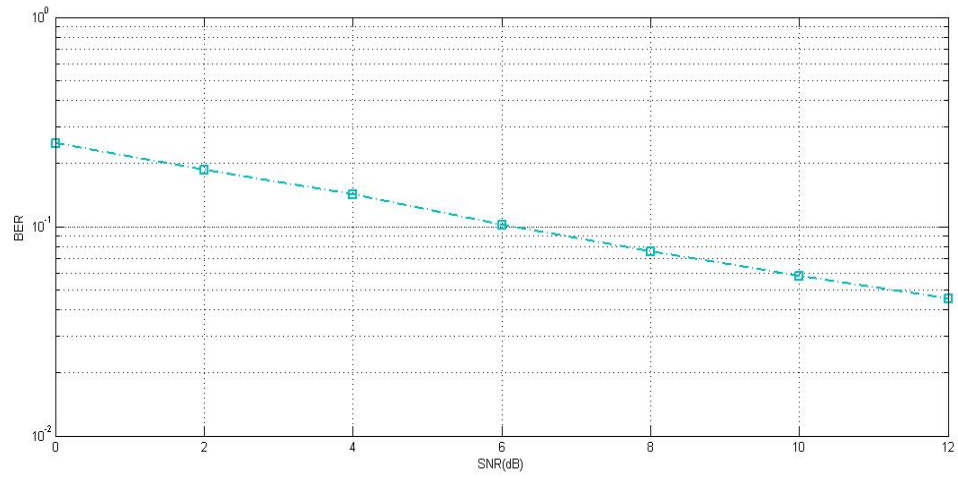

Figures 4.14 (a) BER over Frequency Selective Fast Fading

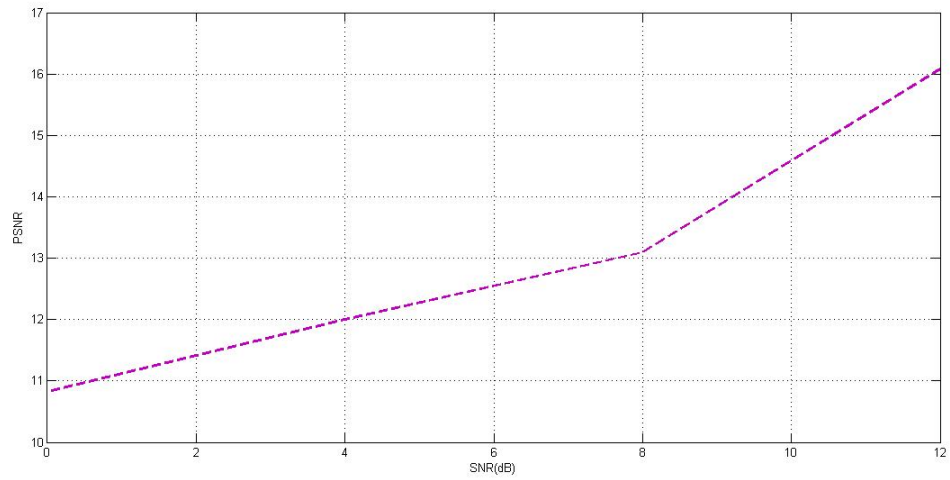

Figures 4.14 (b) PSNR over Frequency Selective Fast Fading

4.4 Discussion of The Results

The results of the OFDM simulation are compared in three criteria. The way that OFDM reacts to different channels can be understood after comparing BERs & PSNRs readings with respect to different SNRs. Figure 4.15 (a) shows the BERs curves of all the channels used in this research. Some readings from these curves at certain SNRs are given in table 4.2. Figure 4.15(b) and Table 4.3 provide similar comparisons in terms of PSNR. Depending on the quality of the received signals BERs and PSNRs, OFDM system shows the best performance over an AWGN channel. Quality of the signal would be excellent in case its power is increased. However, transmission over fading channels in wireless communications showed some distortion in the images. It is clear from the results that the quality of the received signal is worsened when the speed of the mobile is increased as well as going from flat fading to frequency selective fading channel. It very important to remember that OFDM has the ability to handle severe channels conditions. Subcarriers have dealt with the fading issues. Hence, the performance over fading channels is quite acceptable.

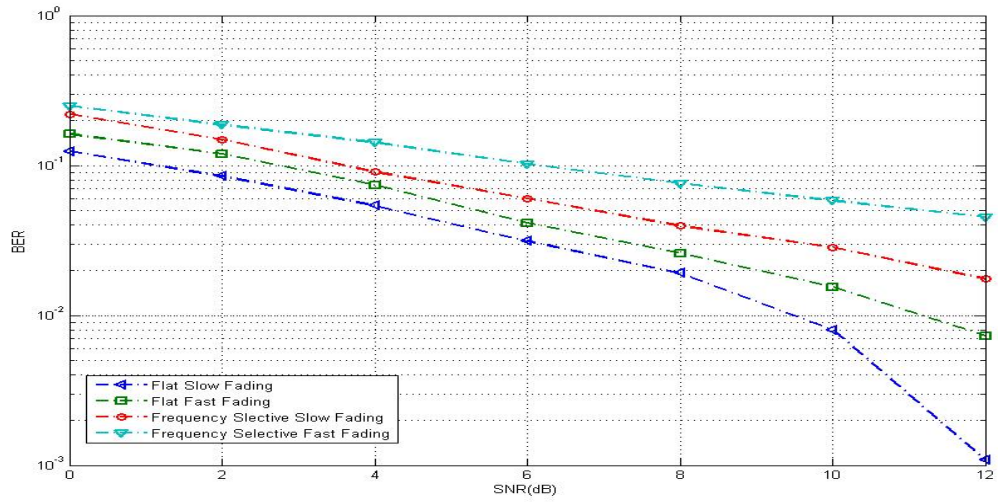

Figure 4.15(a) Comparing BER of The Different Channels

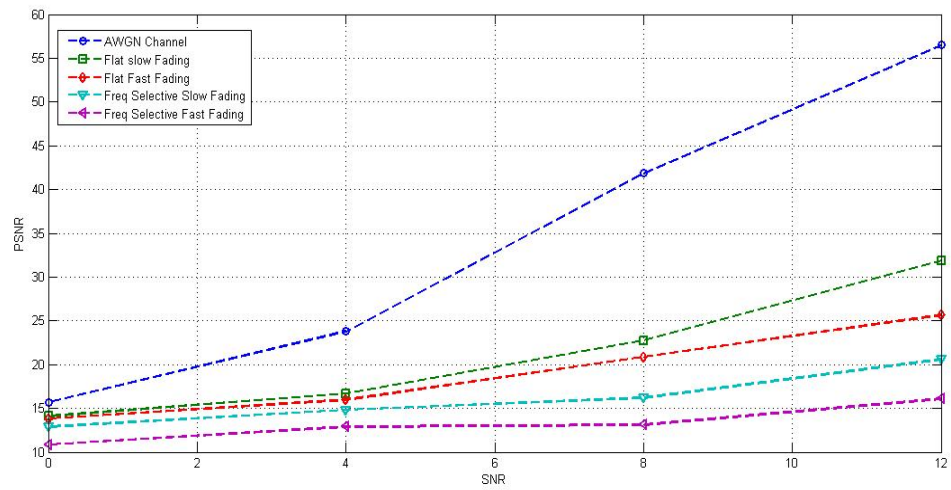

Figure 4.15(b) Comparing PSNR of The Different Channels

Channel \ SNR (dB)	AWGN Fading	Flat Slow Fading	Flat Fast Fading	Frequency Selective Slow Fading	Frequency Selective Fast Fading
0	0.0789	0.1243	0.162	0.22	0.25
2	0.0375	0.085	0.1195	0.149	0.187
4	0.0123	0.054	0.074	0.09038	0.1423
6	0.0024	0.0313	0.0414	0.0602	0.102
8	0.000196	0.0191	0.026	0.0396	0.076209
10	0.00000373	0.0080101	0.0155	0.0284	0.0581023
12	$9 \cdot 10^{-9}$	0.00109	0.0073	0.0175	0.045301

Table 4.2 BER Measurements vs. SNRs for Different Channels

Channel \ SNR (dB)	AWGN Fading	Flat Slow Fading	Flat Fast Fading	Frequency Selective Slow Fading	Frequency Selective Fast Fading
0	15.7	14.1	13.8266	12.9	10.825
4	23.8	16.7	16	14.8	12.9
8	41.84	22.75	20.9	16.19	13.09
12	56.5	31.9	25.67	20.61	16.08

Table 4.3 PSNR Measurements vs. SNRs for Different Channels

Chapter Five: Conclusion and Future Work

5.1 Conclusion

OFDM systems are very efficient in handling bad conditions and high data rates. Fading channels, however, are very common in wireless communications. They affect the process of signal reception after causing losses in transmitted signal. Fading channels include two types of flat fading and two types of frequency selective fading. Effects that fading channels have on the performance of OFDM systems were investigated. MATLAB was used to simulate wireless fading channels that are either based on Doppler spread or delay spread. The quality of received images, BER, PSNRs, is the criteria used to evaluate the extent of these effects. At the same values of SNR, AWGN delivered the best signal. Flat fading and frequency selective fading channels came after respectively. It was also noticed that increasing the speed of the receiver negatively affected the quality of the received signal.

In conclusion, fading that is caused by delay-spread results in less distortion than fading that is caused by Doppler spread. It is proven that distortion to the received signal is higher when the speed of the receiver is increased.

5.2 Future Work

Several ideas could be considered to extend this research in particular or for studying other aspects of OFDM. For example, it is possible that QAM be used instead of MPSK modulation, and then compares outputs of both modulation techniques together. Also, it is possible to further research fading in the Multiple Input Multiple Output OFDM (MIMO-OFDM) Channels. MIMO-OFDM channel estimation, synchronization or frequency-offset estimations are all possible research topics in the future.

References

- [1] Narasimhamurthy, A. B., Banavar, M. K., & Tepedelenlioglu, C. (2010). *OFDM systems for wireless communications*. San Rafael, CA: Morgan & Claypool.
- [2] Maddocks, M. C. D., (1993). An introduction to digital modulation and OFDM techniques. *BBC Research Department, R&D Report 1993-10*.
- [3] Cho, S. C., Kim, J., Yang, Y. Y., & Kang, C. G. (2010). *MIMO-OFDM wireless Communications with MATLAB*. Singapore: Wiley.
- [4] Chuang, J. C. (1987). The effects of time delay spread on portable radio communications channels with digital modulation. *IEEE journal on selected areas in communications*.
- [5] Mathur, S. (2005). Small scale fading in radio propagation. *Wireless Communication Technologies Spring 2005*, 16:332:546
- [6] Zhao, Y., & Haggman, S. G. (1996). Sensitivity to Doppler shift and carrier frequency errors in OFDM System: the consequences and solutions. *IEEE conference proceedings VTC*.
- [7] Engels, M. (2002). *Wireless OFDM systems 2*. (2nd ed.). Boston, MA: Kluwer Academic.
- [8] *Fading channels - Rayleigh fading*. Retrieved April 5, 2012, from <http://gaussianwaves.blogspot.com/2010/02/fading-channels-rayleigh-fading.html>
- [9] Frederiksen, F. B., & Prasad, R. (2002). An overview of OFDM and related techniques towards development of future wireless multimedia communications. *IEEE Radio and Wireless Conference Proceedings*.
- [10] Gayatri, S., Prabhu, P., & Shankar, M. (2002). Simulation of flat Fading using MATLAB for classroom instruction. *IEEE Transactions on Education*.
- [12] Arokiamary, V. J. (2009). *Mobile Communications*. India: Technical Publications Pune.
- [13] Lajevardi, S, *Transmission Over AWGN/ Fading Channels Using OFDM and Performance Analysis*.
- [14] Langton, C. *Orthogonal frequency division multiplex (OFDM) Tutorial*. (2004). Retrieved November 4, 2012, from www.complextoreal.com
- [15] Lasorte, N., Barnes, W. J., & Refai, H. H. (2008). "The history of orthogonal

frequency division multiplexing.” *Communications Society*, 74135.

- [16] Li, X., & Cimini, L. (1997). Effects of clipping and filtering on the performance of OFDM. pp. *EEE Proceedings VTC* (1634-1638. I).
- [17] Litwin, L., & Pugel, M. (2001). The principles of OFDM. *RF Signal Processing*.
- [18] May, T. & Rohling, H. (1998). Reducing the peak to average power ratio of OFDM Radio Transmission Systems. *Proceedings of IEEE VTC '98* (pp. 2474-2478). Ottawa, Canada.
- [19] Retrieved April 30, 2012, from <http://www.kn-s.dlr.de/people/haas/>
- [20] Osman, A. S. (2006). BER performance study of orthogonal frequency division multiplexing (OFDM). *MS Thesis: Universiti Teknologi Malaysia*.
- [21] Peter, W. *The physics of waves and oscillation*. Retrieved June 5, 2012, from http://people.finearts.uvic.ca/~aschloss/course_mat/MU207/wolfenden_article.html
- [22] Ramasami, V. C. *Orthogonal Frequency Division Multiplexing*. Retrieved May 5, 2012, from <http://www.cetuc.pucio.br/~amanda.cunha/projeto/OFDM/Tutorial%20de%20Orthogonal%20Frequency%20Division%20Multiplexing.pdf>
- [23] Rappaport, T. S. (1996). *Wireless communication: principles and practice*. Upper Saddle River, NJ: Prentice Hall.
- [24] Sankar, K. (2008). *Understanding an OFDM transmission*. Retrieved April 15, 2012, from <http://www.dsplog.com/2008/02/03/understanding-an-ofdm-transmission/>
- [25] Sankar, K. (2007). Minimum frequency spacing for having orthogonal sinusoidal. Retrieved April 15, 2012, from <http://www.dsplog.com/2007/12/31/minimum-frequency-spacing-for-having-orthogonal-sinusoidals/>
- [26] Sklar, B. (2001). The Characterization of Fading Channels. Retrieved April 15, 2012, from http://faraday.ee.emu.edu.tr/ee569/art_sklar5_fading.pdf
- [27] Wilkinson, T., & Jones, A. (1995). Minimization of the peak-to-mean envelope power ratio of multi-carrier transmission schemes by block coding. *Proceedings of the IEEE VTC* (pp. 825-829). Chicago.
- [28] Bloul, A, Mohseni, S, Alhasan, B, Ayad, M, & Matin, M. A. (2010). Simulation of OFDM technique for wireless communication systems. *Proc. SPIE*, Vol. 7797,

- [29] *Wireless Intelligent Networking*. Retrieved 5/13/2012 from, <http://www.w-i-n-wireless.com/technology/5ghz.php>
- [30] Chapter 4: Mobile Radio Propagation : Small-Scale Fading and Multipath.”Retrieved 5/13/2012 from http://web.ee.ccu.edu.tw/~wl/wireless_class/Cho%20wireless/ch4.pdf
- [31] Alshammari, A., Albdran, S., & Matin, M. (2012). Study of bit error rate (BER) for multicarrier OFDM. *Proc. SPIE*. San Diego.
- [32] Albdran, S., Alshammari, A., & Matin, M. (2012). The Sensitivity of Bit Error Rate (BER) Performance in Multi-Carrier (OFDM) and Single-Carrier. *Proc. SPIE*. San Diego.
- [33] Bolat, E. (2003). Study of OFDM performance over AWGN channels. Retrieved 4/13/2012 from http://faraday.ee.emu.edu.tr/eaince/gradthesis/OFDM_OVER_AWGN.pdf
- [34] Kumar, S., & Sharma, S. (2010). Error probability of different modulation schemes for OFDM based WLAN standard IEEE 802. 11a. *International Journal of Engineering* (pp. 262–267).
- [35] Ali, S., Rahman, M., Hossain, D., Islam, S., & Islam, M. (2008). Simulation and Bit Error Rate Performance Analysis of 4G OFDM Systems. *11th International Conference On Cooputer and Information Technology* (pp. 138–143).
- [36] Rugini, L., & Banelli, P. (2005). BER of OFDM systems impaired by carrier frequency offset in multipath fading channels. *IEEE Proc: Transactions on Wireless Communications*, vol. 4, no. 5 (pp. 2279–2288).
- [37] Howald, R. L., Kesler, S., & Kam, M. (1998). BER performance analysis of OFDM-QAM in phase noise. *IEEE Proceedings: International Symposium on Information Theory* (p. 256-261).
- [38] Noor, L Anpalagan, A., & Kandeepan, S. (2007). SNR and BER derivation and analysis of downlink OFDM systems with noisy fading Doppler channels. *9th International Symposium on Signal Processing and Its Applications* (pp. 1–4).
- [39] Liu, X., & Hanzo, L. (Apr. 2007). Exact BER analysis of OFDM systems communicating over frequency-selective fading channels subjected to carrier frequency Offset. *IEEE 65th Vehicular Technology Conference - VTC2007-Spring*, vol. 0, no. 1, (pp. 1951–1955).

- [41] Athaudage, R. N. (2002). BER sensitivity of ofdm systems to time synchronization error. *The 8th International Conference on Communication Systems*.
- [42] Ma, X., Kobayashi, H., & Schwarrz, S.C. (2003). Effect of frequency offset on BER of OFDM and single carrier. *PIMRC 14th IEEE Proceedings*.
- [43] Haggman, S. G. (1998). BER analysis of OFDM communication systems with inter carrier interference. *1998 International Conference on Communication Technology, Proceedings (IEEE Cat. No.98EX243)*, vol. vol.2, p. 5.
- [44] Lee, K. H., Chang, N., & Kang, J. (2007). Design of novel orthogonal space-time-frequency block codes for OFDM systems Over Fading Channel environments. *2007 IEEE 66th Vehicular Technology Conference* (pp. 521–525).
- [45] Ali, B. M., & Jamuar, S.S. (2008). Space-time and space-frequency OFDM with conventional proceeding over fading channels. *TENCON 2008 IEEE Region 10th Conference*.
- [46] Alshammari, A., Alabdran, S., & Matin, M. (September 2012). Effects of Fading Channels on OFDM. *IOSR Journal of Engineering*, 2(9), 116-121.
- [47] Alabdran, S., Alshammari, A., & Matin, M. (September 2012). Clipping and Filtering Technique for reducing PAPR In OFDM. *IOSR Journal of Engineering*, 2(9), 91-97.

Appendix A

(Journal Publication)

IOSR Journal of Engineering (IOSRJEN)

e-ISSN: 2250-3021, p-ISSN: 2278-8719, www.iosrjen.org

Volume 2, Issue 9 (September 2012), PP 116-121

Effects of Fading Channels on OFDM

Ahmed Alshammari, Saleh Albdran, and Dr. Mohammad Matin

Department of Electrical and Computer Engineering University of Denver

Abstract—One of the essential components of recent communications is Orthogonal Frequency Division Multiplexing (OFDM). Handling bad conditions, high bandwidth and using the available spectral efficiently are some of its characteristics. Hence, it has replaced old communication technologies in many systems such as wireless networks and 4G mobile communications. In this paper, Effects of fading channels on OFDM are investigated. MATLAB is used to simulate wireless fading channels environments that are either based on Doppler spread or Delay Spread.

Key Words— OFDM, ISI, BER, PSNRs

I. INTRODUCTION

High data rates are demanded a lot in modern communications. It is the huge development in the communications industry that led to this demand. Also, better quality and lower BER became more important. OFDM technique, which was introduced in the 1960's, provides all that [1][2]. It was not practical at that time because technologies to apply did not exist then e.g. it was not possible to have processors that can perform IFFT and FFT. In the 90's many of those problems were solved and OFDM started getting more popular since then.

Multi carrier modulation is the backbone of the OFDM technique. Hence, data are split to many parallel streams, which decreases bit rate. OFDM system of modulates several subcarriers using these parallel sub streams. OFDM's ability to transmit data with high speed is the main reason it is getting so popular besides robustness against Inter symbol interference (ISI). Therefore, many wireless and wired communication standards around the world have adopted this kind of modulation.

OFDM system model used in this paper is shown in Figure 1. Series to parallel conversion of the data stream results in the blocks of data symbols that we are transmitting. Assuming that N is the number of these blocks then OFDM symbols are characterized by $X_m = (x_{0,m} x_{1,m} \dots x_{N-1,m})^T$. After that each one of the symbols modulates one subcarrier. A guard band of length N_{cp} is attached to each OFDM symbol. The m^{th} OFDM symbol is given by equation (1).

$$S_m(n) = \begin{cases} \frac{1}{N} \sum_{k=0}^{N-1} x_{k,m} e^{j2\pi k(n-N_{cp})/N} & \text{for } n \in [0, N + N_{cp} - 1] \\ 0 & \text{otherwise} \end{cases} \quad (1)$$

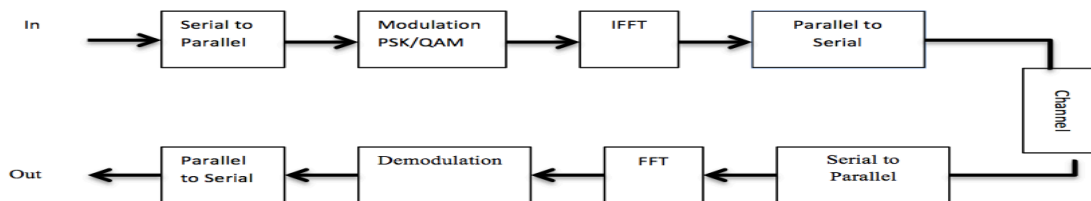

Figure 1 Block diagram of the OFDM system

Equation (2) represents the received signal $r(n)$ [3]. We can notice that the received signal is the summations of the white Gaussian noise (AWGN) $n(n)$ and the convolution of the channel's impulse response $h(n)$.

$$r(n) = \sum_{\eta}^{n_{cp}-1} h(\eta)s(n-\eta) + n(n) \quad (2)$$

II. FADING

Communication channel is the medium that connects the transmitter and the receiver. Channels could vary according to the nature of the system. The loss in the signal as it approaches the receiving side is caused by random attenuations. In wireless environment, it is possible that signals propagate through two or more paths before reaching the receiver in a phenomenon that is known as multipath propagation. There are many reasons that can cause multipath such as atmospheric conditions or lack of direct path. Phase shifting, destructive and constructive interference are some of the consequences of this phenomenon [4]. Hence, received signal could have different amplitude and phase because of change in the propagation time and the intensity distribution of the waves [5].

2.1 Small Scale Fading

Small scale fading is controlled by the nature of the sent signal and communication environments. Symbol duration, Bandwidth and channel parameter are factors that decide the type of fading channel. Small scale fading could be divided into two main categories as shown in figure 2:

1) Fading Due To Delay Spread: Delay spread can cause two types fading that are either frequency selective slow and frequency selective fast fading [5]. Flat fading is the most popular types of fading. It occurs when the bandwidth of the signal is less than the bandwidth of the channel. The power of the signal is reduced in this case as a consequence to the gain variation of the channel when the spectrum remains the same. In frequency selective fading: linear phase response and constant gain are the main characteristics. Bandwidth of the channel is smaller than that of the signal, which is distorted by frequency selective, fading due to the multiple version of the signal with various amplitudes that are received.

2) Fading From Doppler Spread: it is either flat slow or flat fast fading caused by Doppler spread. In slow fading, symbol period is more than coherence. In Fast Fading, impulse response of the channel variations are very fast i.e. symbol duration of the transmitted signal is more than the coherence time.

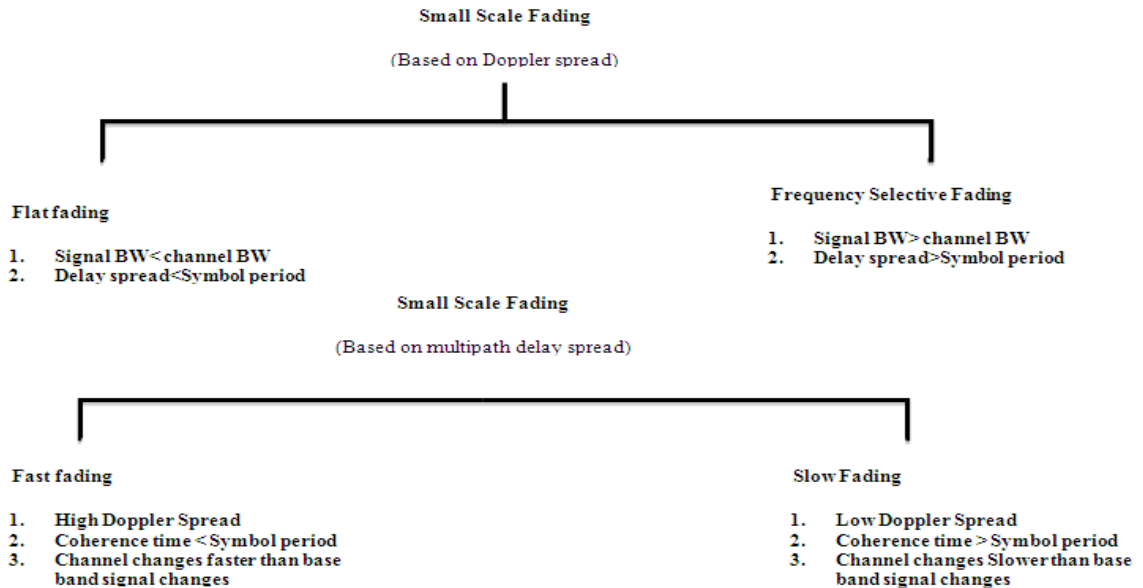

Figure 2 Small Scale Fading

2.2 Factors affecting fading:

Four things could affect small scale fading:

- 5) Mobile speed: moving mobile could experience positive or negative Doppler shift. When the mobile moves closer to the transmitting side positive Doppler spread happened while Negative Doppler spread occurs the other way around.
- 6) Multipath Propagation: Signal energy is consumed by phase, amplitude and time in multipath environment. Multiple versions of the signal with various arriving instants and shifted spatial orientation. The duration that the signal takes to get to the receiver is increased in multipath channels.
- 7) Bandwidth of The Channel: When the bandwidth of the channel is less than that of the signal transmitted, it gets distorted. The channel transfer function must be flat in order for its bandwidth to be coherent. Transfer function of the channel is flat whenever the phase response is linear with a constant gain [6].
- 8) Velocity of objects within the channel: Objects in the communication environment sometimes are moving. If that movement is of a speed that is more than that of the receiver, small-scale fading happens otherwise we can ignore those movements.

III. CHANNEL MODELING

Time variant impulse response of the channel is used to model it. Motion of the receiver is the variable that affects time changing. Equation (3) calculates the received signal.

$$y(d, t) = \int_{-\infty}^t x(\tau)h(d, t - \tau)d(\tau) \quad (3)$$

Where $h(d, t)$ is the impulse response of the channel and $x(t)$ is the signal. If $d = vt$ is the position of the receiver and v is a constant, it is possible to replace d in equation (3) with vt as in equation (4).

$$y(vt, t) = \int_{-\infty}^t x(\tau)h(vt, t - \tau)d(\tau) \quad (4)$$

$$h_b(t, \tau) = \sum_{i=0}^{N-1} a_i(t, \tau)e^{[j(2\pi f_c \tau_i(t) + \varphi_i(t, \tau))]} \delta(\tau - \tau_i(t)) \quad (8)$$

Channel impulse response can be found using (5). Where, $a_i(t, \tau)$ are the amplitudes and $\tau_i(t)$ are the delays whereas $\theta_i(t, \tau) = 2\pi f_c \tau_i(t) + \varphi_i(t, \tau)$ represent phase shift in the i th component.

The impulse response can be found using equation (9) for time invariant channel where every multipath components of that channel have delay.

$$h_b(\tau) = \sum_{i=0}^{N-1} a_i(t, \tau)e^{[j\theta_i(t, \tau)]} \delta(\tau - \tau_i(t)) \quad (9)$$

3.1 Clarke's Model

Clarke's Model relies on scattering to discover the statistical characteristics of the channel. Beside the assumption of fixed transmission antenna that is vertically polarized, N normalized plane waves of the antenna with a random carrier phases angles of arrival are assumed while amplitude remains unchanged. When the receiver is moving, m_{th} wave that has arriving angle α_m with respect to the x-axis. Doppler shift is given by equation (10).

$$f_m = \frac{v}{\lambda} \cos \alpha_m \quad (10)$$

Where, λ is the wavelength of incident wave.

Every received wave has a different carrier frequency with small shift from the center frequency. The power spectral density of the output is given by equation 11. It is clear from that equation that the PDF is zero when $|f - f_c| > f_m$. With center frequency f_c , Spectrum is limited to $\pm f_m$ and all the received waves has different carrier frequencies that are shifted.

$$S(f) = \frac{A[q(\alpha)G(\alpha) + (-\alpha)G(-\alpha)]}{f_n \sqrt{1 - (\frac{f - f_c}{f_m})^2}} \quad (11)$$

Assuming a vertical $\frac{\lambda}{4}$ antenna, $G(\alpha) = 1.5$ and $p(\alpha) = \frac{1}{2\pi}$ over 0 to 180° , then $S(f)$ becomes as in equation (12).

$$S(f) = \frac{1.5}{\pi f_m \sqrt{1 - (\frac{f-f_c}{f_m})^2}} \quad (12)$$

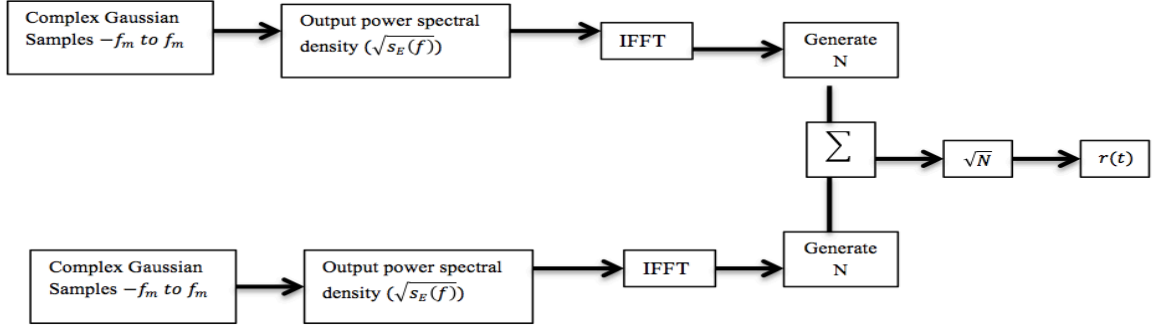

Figure 3 Rayleigh fading implementation

The block diagram in figure 3 was used to simulate Rayleigh fading in the frequency domain. First, The signal is modulated with In-phase & quadrature modulation. Thus, two independent Gaussian low pass noise components are used to create these components. IFFT is implemented as the last step in the simulation process in order to shape the random signal.

The simulator in figure 3 is impended according to the following steps [5]:

- Determine the number of points in frequency domain N which describes the square root of PDF $\sqrt{S_{E_z}(f)}$ and the max Doppler frequency shift f_m should be specified as well.
- Find out the time duration of the fading waveform that is given by $T = \frac{1}{\Delta f}$.
- Create complex Gaussian Radom variables for each $\frac{N}{2}$ positive frequency components.
- Conjugate positive frequencies in order to find the negative ones.
- Multiply the in-phase and quadrature components by fading spectrum $\sqrt{S_{E_z}(f)}$
- Apply IFFT on the in-phase and quadrature components in order to obtain two N times series. Sum the squares of each signal point.
- Take the square foot of the summation done in the previous step in order to obtain the N Pint time series with the Doppler spread and the time correlation for the Rayleigh fading.

IV. RESULTS

OFDM technique is studied over wireless communication environment to examine the effects of fading. MATLAB to simulate the process of transmitting image signals over fading channels with various SNRs. OFDM model discussed in the first part of this paper was followed and Fading channels were implemented according to Clarke's model. It assumes that there is no line of sight between transmitter and receiver ends. For flat and frequency selective fading, the speed of the receiver was either slow 3-miles/hour or fast 100-miles/hour. 3 Miles/hour was assigned as the speed of the receiver for the purpose of simulating Small Doppler Spread and 100 Miles/hour was used to simulate large Doppler Spread. Figures 4 and 5 shows images sent over Flat slow Fading and Flat Fast Fading channels respectively with different SNRs. It is clear that quality of the received signals is improved at higher SNRs. Also, images have more distractions at higher speeds of the receiver. Therefore, the OFDM system delivers better images than over flat slow fading.



Figure 4 Image sent Over Flat Slow Fading Channel with Different SNRs

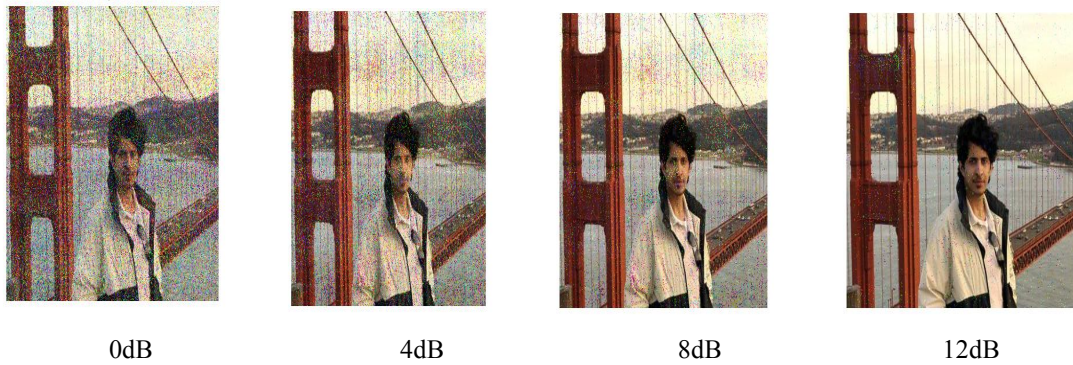

Figure 5 Image sent Over Flat Fast Fading Channel with Different SNRs

For Frequency selective fading environment, Multiple Clarke's model was used. Multiple delayed versions of the transmitter signal are subjected to Clark's model to simulate frequency selective Fading. 4 different paths are assumed with delay of 0,4,8 and 16 samples. As done in flat fading, 3 Mile/hour mobile speeds was used in the simulation for frequency selective slow fading and 100 Mile/hour speed was used to simulate Frequency Selective Fast Fading. Figures 6 and 7 shows BER over Frequency Selective Slow Fading and Frequency Selective Fast Fading respectively.

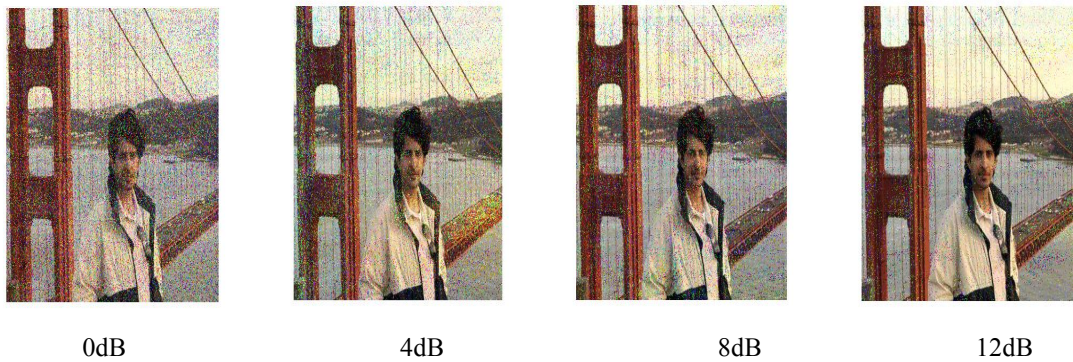

Figure 6 Image sent Over Frequency Selective Slow Fading Channel with Different SNRs

Similarly, Quality of the received images is improved at higher SNRs for frequency selective fading channel. However, images have more distractions at high receiver speeds. Therefore, OFDM system delivers better images over Frequency Selective slow fading than frequency selective fast fading when the speed of the receiver is increased.

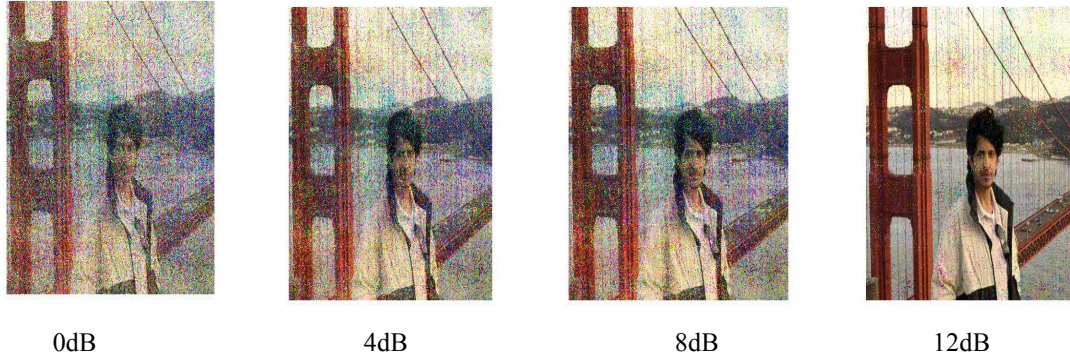

Figure 7 Image sent Over Frequency Selective Fast Fading Channel with Different SNRs

OFDM system shows a better performance over flat fading than frequency selective fading. Also, the quality of the received signal is less when the mobile is moving with higher speeds. BER of the four kinds of Fading are shown in figure 8. It is clear that the signal received in frequency selective fading channel environment has more BER than the one that is received in flat fading channel environment.

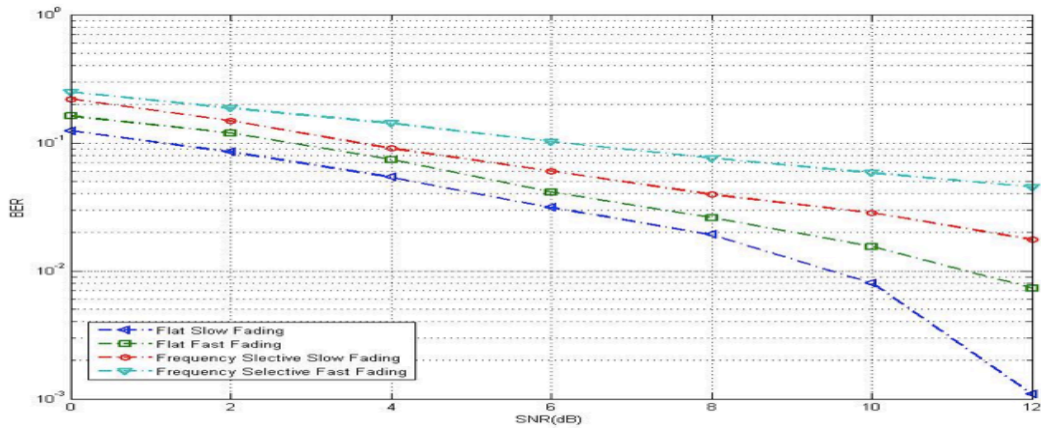

Figure 8 Comparing BER of The Different Channels

Peak-Signal-to-Noise Ratio (PSNR) is used to measure reconstruction quality of the received signal. It is simply the ratio between the power of the original signal and the power of the disturbing noise that affect the quality of the received signal. PSNRs curves for the received images are shown in figure 9. We can see the OFDM System delivers images with more PSNRs flat fading channel than in frequency selective fading channel.

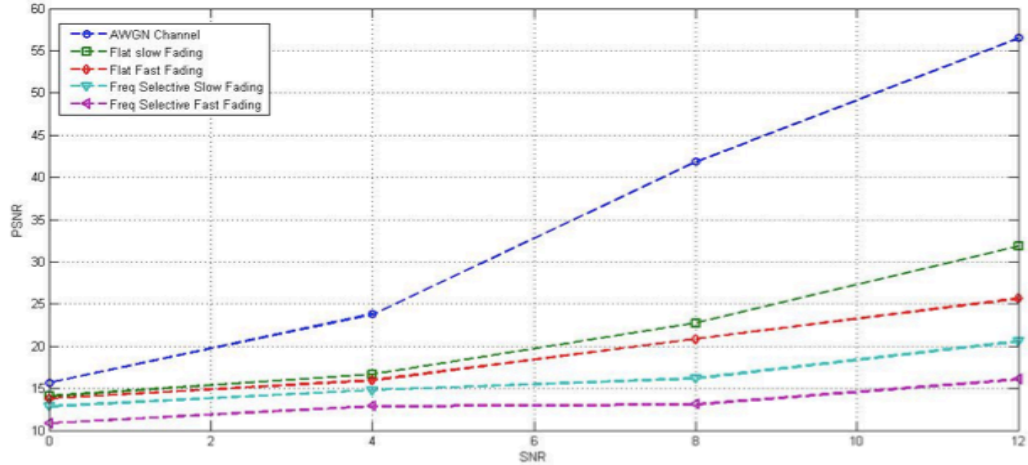

Figure 9 Comparing PSNR of The Different Channels

V. CONCLUSION

OFDM systems are very efficient in handling bad conditions and high data rates. Fading channels, however, are very common in wireless communications. They affect the process of signal reception after causing losses in transmitted signal. These effects that fading channels have on the performance of OFDM systems are investigated. MATLAB was used to simulate wireless fading channels that are either based on Doppler spread or Delay Spread. Quality of received images, BER, PSNRs is the aspects used to evaluate the extent of these effects. In conclusion, fading that is caused by delay spread caused less distortion than fading that result from Doppler spread. We found that Distortion to the received signal is higher when the speed of the receiver is increased.

VI. REFERENCES

- [1] BBC Research Department, E. D. An introduction to digital modulation and OFDM techniques, 1993.
- [2] Y. Cho, J. Kim, W. Yan, & C. Kang, *MIMO-OFDM wireless communications with MATLAB*. (Singapore: Wiley, 2010).
- [3] R. Frederiksen, F. Prasad, An overview of OFDM and related techniques towards development of future wireless multimedia communications, *IEEE Radio and Wireless Conference Proceedings*, 2002.
- [4] W. Spring, & T. Mathur, Small scale fading in radio propagation, 2005.
- [5] T. Rappaport. *Wireless Communication*. (Upper Saddle River, NJ: Prentice Hall, 1996).
- [6] J. C. Chuang, The effects of time delay spread on portable radio communications channels with digital modulation, *IEEE journal on selected areas in communications*, 1987.
- [7] V. Jeyasri, Mobile communications, India: Technical Publications Pune, 2009.
- [8] M. Engels. *Wireless OFDM systems 2* (Boston: KLUWE Academic, 2002).
- [9] S. Gayatri, P. Prabhu, & M, Shankar, Simulation of flat fading using MATLAB for classroom instruction. *IEEE TRANSACTIONS ON EDUCATION*.
- [10] K, SANKAR. Understanding an OFDM transmission, 2008. Retrieved April 15, 2012, from <http://www.dsplog.com/2008/02/03/understanding-an-ofdm-transmission>
- [11] K. Lee, H. Lee, N. Chang, and J. Kang, Design of novel orthogonal space-time-frequency block codes for OFDM systems Over Fading Channel Environments, *Proc. IEEE 66th Vehicular Technology Conference*, 2007, pp. 521–525.

Clipping and Filtering Technique for reducing PAPR In OFDM

Saleh Albdran¹, Ahmed Alshammari², Mohammad Matin³
¹(Electrical & Computer Engineering Department, University of Denver)
(smbdran@hotmail.com)

Abstract— Recently, Orthogonal Frequency Division Multiplexing (OFDM), as a multi-carrier, and a single carrier transmission systems are used widely in the communications industrial systems. Each one of these two techniques has their own advantages and disadvantages. To maintain a high data rate, OFDM is preferred over the single-carrier transmission system due to several shortages like, complexity of equalizing that increases proportionally with the data rate. To overcome this problem, OFDM is used as a transmission system with much better Bit Error Rate (BER) performance. Peak-to-Average-Power ratio (PAPR) is major drawback of using OFDM but we can deal with it using clipping and filtering as a power reduction technique.

Keywords— Additive White Gaussian Noise (AWGN), BER, high data rate, Multi-Carrier, OFDM, Single-Carrier (SC),

I. INTRODUCTION

During the last few years, the wireless communications went through several improvement stages in a fast way and as a result of that, the demand on the wireless services has growth rapidly as well. Due to the unpredictable nature of the wireless channels, calculating the propagation and the noise is not easy. On the other hand, the wired channels have less complexity of calculating the noise because that the signal propagates in a fixed path. One of the reasons to have signal degradation is the Additive White Gaussian Noise (AWGN) that could be occurred due to industrial or natural sources. There are also several types of fading channels include: multipath fading, frequency selective fading and others.

It is much easier to use single-carrier transmission scheme due to the simplicity and accuracy that is provided especially with the low data rate. This technique has its own advantages like the simplicity of transmitting the signal through a flat fading channel and saving more power since there is no need to extend the bandwidth by inserting guard interval. However, the use of single-carrier may have actual drawbacks with high data rate including equalizing complexity. Also Inter Symbol Interference (ISI) is a serious issue that appears with the multipath fading or frequency selective fading channels. OFDM is used to overcome the shortages of the single-carrier transmission scheme in the case of having high data rate [1]. The high bandwidth efficiency is one of the OFDM advantage in the case of having a big number of subcarriers. Also, with the OFDM scheme there is much lower chance to have ISI. Nevertheless, there are some OFDM drawbacks that could be the low bandwidth efficiency for having small subcarrier number. Also, we might have high peak values because of the IFFT operation in the transmitting side.

Frequency Division Multiplexing (OFDM), as a multiple carrier, outperforms the single carrier for communication systems mainly in high data rate. OFDM is getting so popular since it is less exposed to multipath effects, that makes it the core technique for the future standard systems, beside the high

efficiency of its spectrum [2]. The main drawback of OFDM is the peak to average power ratio (PAPR) performance, which rises so high because of amplifiers nonlinear effects. The high PAPR essentially reduces the efficiency of the output power amplifier (PA). There are several techniques, to reduce the PAPR, which are divided into different categories: clipping technique, coding technique, probabilistic technique and so on [3] [4]. In this paper we will use clipping and filtering technique scheme to reduce the PAPR because of its easiness. However, this process could cause in-band distortion or out-of-band radiation, which could destroy the signal or disturb the adjacent channel. The paper is organized as follow: In section II a short definition of the OFDM and the PAPR to state the main concepts. Then, a brief explanation and description of the system in section III. After that in section III there is some details regarding the clipping and filtering technique. In section IV a simulation results is placed with extended details. Finally in section V, we conclude this paper with some of our observations.

II. SINGLE-CARRIER TRANSMISSION

In Fig1, there is a block diagram for a typical end-to-end single-carrier scheme. This transmission system is contains of a band-limited channel denoted by $h(t)$, the transmit mapper $g_T(t)$, the receiver demapper $g_R(t)$ and equalizer symbolized by $h^{-1}(t)$. The transmitted symbols a_n have a period of T for each symbol and the data rate is presented as $R = 1/T$. The output of the process is shown in the following equations (1) and (2) where the AWGN is denoted by $z(t)$:

$$y(t) = \sum_{m=-\infty}^{\infty} a_m g(t - mT) + z(t) \quad (1)$$

$$g(t) = g_T(t) * h(t) * g_R(t) * h^{-1}(t) \quad (2)$$

We made assumption in this paper that the transmitted signal is recovered from the fading and noise effects using the equalizer. Since this assumption is made, the noise in the previous equations is ignored and the noise-free output can be formed as follow:

$$y(t) = \sum_{m=-\infty}^{\infty} a_m g((n - m)T) \quad (3)$$



Fig1: Model of single-carrier transmission system.

In the stages of mapping and de-mapping, different modulation techniques could be used. Quadrature Amplitude Modulation (QAM) and Phase Shift Keying (PSK) are used in this paper as a

modulation technique. The input sinusoidal signal can be mapped to two components the In-phase component $I(t)$ and the Quadrature component $Q(t)$. To explain the concept of modulation procedure, we can take Binary PSK as an example. In the case of having BPSK, there are two possible values, 0 or 1. While, if QPSK is used, we would have two binary digits at a time, (00,01,10,11). Table1 show the mapped component represented in terms of Q and I:

Table 1: Converting binary digits to complex form.

Binary Digits	I(t)	Q(t)
00	$1/\sqrt{2}$	$1/\sqrt{2}$
01	$1/\sqrt{2}$	$-1/\sqrt{2}$
10	$-1/\sqrt{2}$	$1/\sqrt{2}$
11	$-1/\sqrt{2}$	$-1/\sqrt{2}$

III. MULTI-CARRIER (OFDM)

To over come the shortages that appear using single-carrier transmission, OFDM is used as a multi-carrier transmission [4]. Fig2 shows a block diagram for the OFDM transmission system where it has two main parts: transmitting side and receiving side. The signal gets into the transmitting side starting with mapping process. Then the output of the operation is converted from serial form to parallel form making shorter symbols sequences. A pilot is inserted in between the sub-carrier seeking a way to estimate a start of the OFDM symbols. Afterward the output signal goes through the IFFT operation before adding the Cyclic Prefix (CP). The use of the IFFT is so important to overcome the use of huge number of RF oscillators. The last stage in the receiver is the parallel to serial convertor.

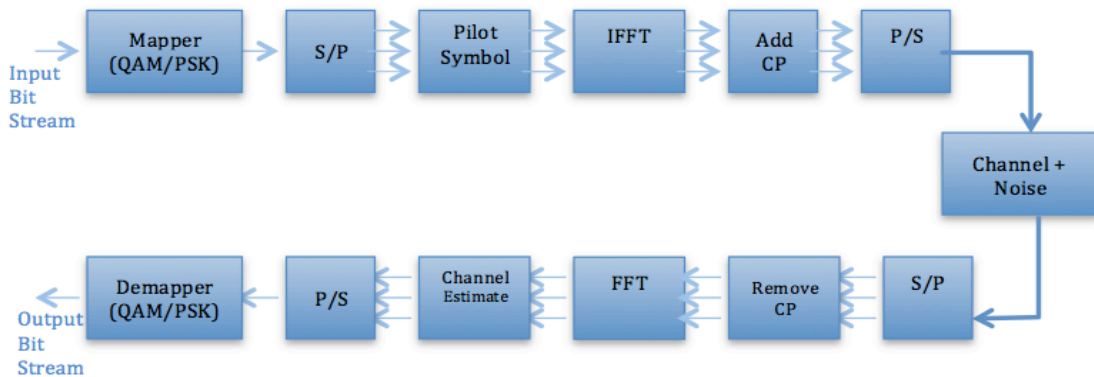

Fig2: Model of Multi-carrier transmission system (OFDM).

Orthogonality should be achieved to ensure better spectral efficiency for the system and maximum capacity for the transmitting channels. The aim of maintaining orthogonality is to prevent the overlapped of center frequency for the subcarrier and giving a chance for the spectrums of the subcarriers to overlap

desiring higher spectral efficiency. Assume there is complex exponential signal $\{e^{j2\pi f_k t}\}_{k=0}^{N-1}$ that represents the subcarriers in the OFDM signal while we have $f_k = k/T_{sym}$. To check the orthogonality of any two sub-carriers in the OFDM signal, the following conditions can be applied as shown in equation (4):

$$\begin{aligned} \frac{1}{T_{sym}} \int_0^{T_{sym}} e^{j2\pi f_k t} e^{-j2\pi f_i t} dt &= \frac{1}{T_{sym}} \int_0^{T_{sym}} e^{\frac{j2\pi k}{T_{sym}} t} e^{-\frac{j2\pi i}{T_{sym}} t} dt \\ &= \frac{1}{T_{sym}} \int_0^{T_{sym}} e^{\frac{j2\pi(k-i)}{T_{sym}} t} dt \\ &= \begin{cases} 1, & \text{when } k = i \\ 0, & \text{otherwise} \end{cases} \end{aligned} \quad (4)$$

If the dot product of the tested signals is not equal zero, we can say that these two signals did not fulfill the orthogonality condition, otherwise the two signals are orthogonal to each other. To prevent ISI, guard intervals are used to be inserted between the OFDM symbols to avoid the overlapping that could be caused by transmitting delay. The used of guard intervals is so important to ensure a symbol full attenuating. There are several types of guard intervals: zero padding, cyclic prefix (CP) and cyclic suffix (CS). In this paper we inserted CP as guard intervals to prevent ISI. On the receiving side, the signal is down converted to get the base-band signal and we make assumption that both side of the system, the receiver and the transmitter, are synchronize in time. After that, the received signal is converted from serial to parallel form to have shorter sequence in length. Then the CP is removed from the signal preparing it to proceed through the FFT operation. In the ideal case, we would have perfect output, which is impossible in practical operations.

IV. PEAK-TO-AVERAGE POWER RATIO (PAPR)

Depends on the ratio between the maximum power of the complex pass-band signal and the mean power of it, we can calculate the PAPR. The value of PAPR can be calculated as following equation shows [7]:

$$PAPR = \frac{\max(x^2(t))}{\text{mean}(x^2(t))} \quad (5)$$

Where $x(t)$ is presented in the equation to denote the amplitude of the complex pass-band signal. To calculate the probability of having PAPR greater than the threshold value for the OFDM signal, we could use Complementary Cumulative Distribution Function (CCDF). By simulating the CCDF, we compare the theoretical values with the simulation results and the PAPR keeps increasing when the number of carriers increases. In the simulation part there is a figure showing the CCDFs of OFDM signals with different number of subcarriers.

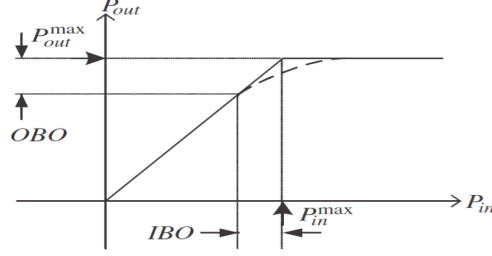

Fig3: Input and output characteristic of an HPA [5].

If we use linear amplifiers that they have larger input than the nominal value, we could have an output with a nonlinear distortion. In Fig3, there is a diagram for High Power Amplifier (HPA) showing the input and output characteristic. In this diagram, the input power is denoted by P_{in} while the outputs power is represented by P_{out} . To keep the linearity, the maximum output power is limited by the value P_{out}^{max} and the maximum input power is pounded by P_{in}^{max} . Both the input and output power are backed off to insure a linear operation and the area of the backing off is termed by Input Bach-Off (IBO) and Output Back-Off (OBO). The following two equations describe the IBO and the OBO in terms of the input-output power and the maximum input-output power:

$$IBO = 10 \log_{10} \frac{P_{in}^{max}}{P_{in}} \quad (6)$$

$$OBO = 10 \log_{10} \frac{P_{out}^{max}}{P_{out}} \quad (7)$$

In the case of having nonlinear HPA characteristic, which is caused by having larger input than its nominal value, we could have out-of-band radiation that makes an overlap between the adjacent signals [8]. Also there is another problem that appears with the nonlinear characteristic of HPA that is the in-band distortion causing a serious issues including attenuation, spinning and offset the received signals.

V. CLIPPING AND FILTERING

The clipping is the easiest technique to reduce the power by setting a maximum level for the transmitted signal [9]. Though, this technique has several disadvantages:

- The performance of BER could be affected negatively due to the in-band distortion caused by the clipping.
- Also out-of-band radiation usually appears with clipping technique that could disturb the adjacent channels.

However, we can use filtering operation to decrease the appearance of the out-of-band radiation but the signal may exceed the maximum level of the clipping operation [10]. The block diagram of clipping and filtering technique for PAPR reduction is exposed in Fig4. In this figure, N denotes the number of subcarrier and L represents the oversampling factor. In the diagram, The IFFT generate $x'[m]$ which is the L -times oversampled signal. As shown in fig4, the FFT-IFFT filter is applied to allow the signal passing through a band-pass filter (BPF) then through a low-pass filter (LPF). The outcome of the filtering stage is a less degraded BER performance and a reduced out-of-band radiation. Though, the PAPR reductions improvements are gained at the cost of regrowth the peak where the signal could go beyond the clipping level after applying the filtering operation.

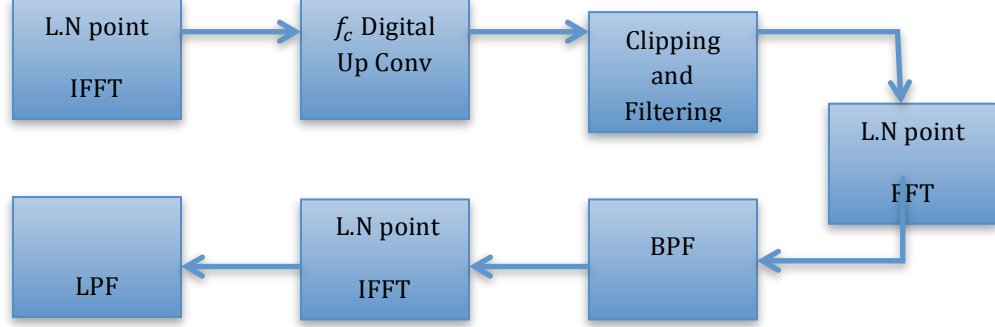

Fig4: The scheme of clipping and filtering technique for PAPR.

The signal $x^p[m]$ is the passband modulated one with carrier frequency f_c . We symbolize the clipped form of the passband-modulated signal as $x_c^p[m]$. The expression of this signal is shown in following equation:

$$x_c^p[m] = \begin{cases} -A & x^p[m] \leq -A \\ x^p[m] & |x^p[m]| < A \\ A & x^p[m] \geq A \end{cases} \quad (8)$$

Where the clipping level is denoted by A and (CR) is the clipping ratio that can be represented as follow:

$$CR = \frac{A}{\sigma} \quad (9)$$

Where the RMS value of OFDM signal is denoted by σ and it is well known that $\sigma = \sqrt{N}$ for the baseband and $\sigma = \sqrt{N/2}$ for the passband OFDM signal.

VI. SIMULATION RESULTS

The BER performance is investigated in this comparison using MATLAB code. The definition of the BER can be explained as the effected bits divided by the whole number of the transmitted bits over a time interval [11]. This calculation provides us with a percentage quantity that is a unit-less. In Fig5, there is two curves represent a comparison between the OFDM and the SC transmission systems. The comparison shows the BER performance when we use 4QAM. From the curves we can see that the OFDM transmission system improves the BER percentage compared to the SC. As we stated before, the use of the OFDM transmission has a main drawback, which is the PAPR distribution as shown in Fig6.

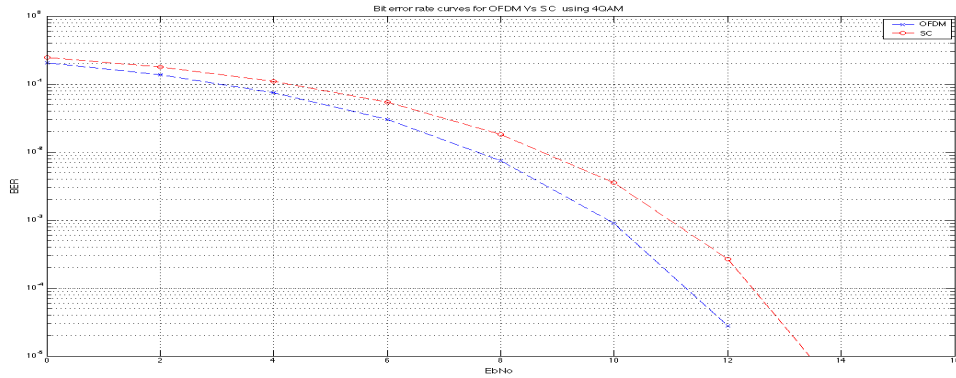

Fig5: BER curves for OFDM Vs. SC using 4QAM.

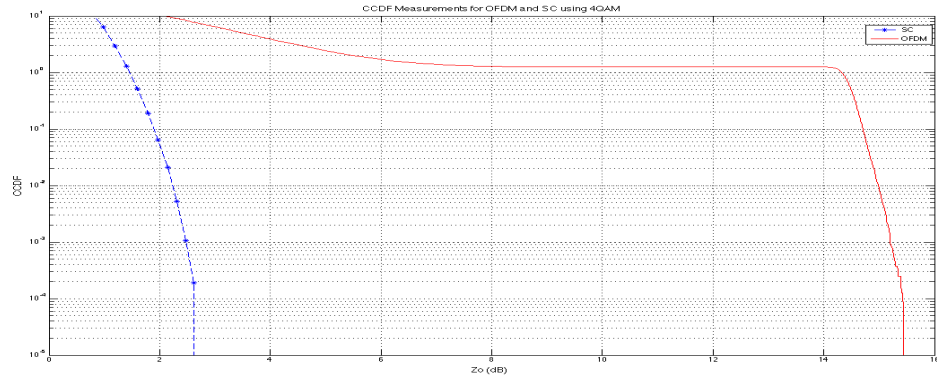

Fig6: CCDFs of OFDM Vs. SC using 4QAM.

Because crest factor (CF) is the square root of PAPR, CCDF of the CF represents the PAPR distribution. Fig7 shows CCDFs of CF of the OFDM signals after clipping with three different values for clipping ratio. There is an obvious drop in the PAPR of the OFDM signal after clipping. It can be seen as well that the highest PAPR reduction effects happens at the lowest clipping ratio. Fig7 shows that the PAPR is 14.3dB for the unclipped signal at CCDF of 10^{-1} . When we apply a clipping ratio (CR) of 1, PAPR is reduced to 5.2dB after applying this algorithm for the same values of CCDF. On the other hand, the BER performance is worsen badly as shown in Fig8 at it gets better when the CR get higher.

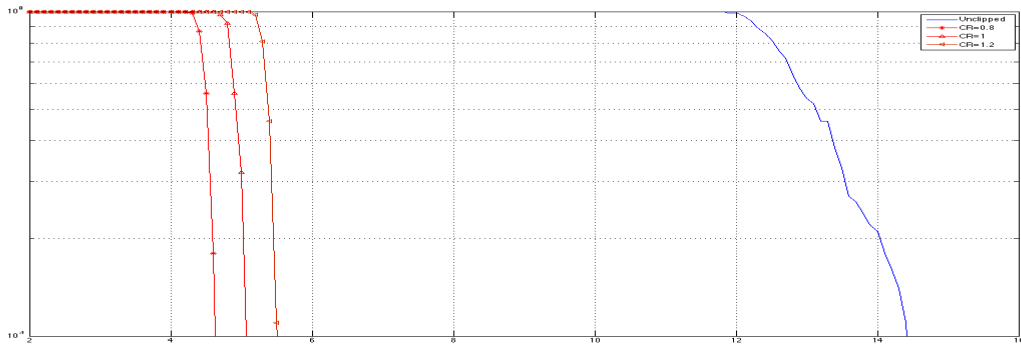

Fig7: PAPR distribution for clipped and unclipped signals.

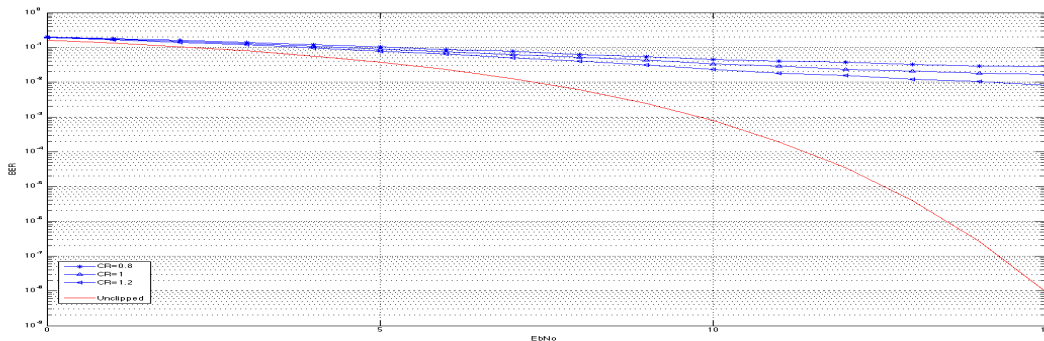

Fig8: BER for clipped and unclipped signals.

Fig9 shows the effect of the clipping and filtering on the PAPR performance where the PAPR is reduce clearly after applying this power reduction technique. The performance of BER for the clipping and filtering technique with respect to the signal to noise ratio (SNR) is compared to the unclipped OFDM signal BER as shown in fig10. Different clipping ratios have been used. It is clear that the performance of the BER get worse as the CR gets lower. The BER of the clipped and filtered signal is 0.0039 at 10 dB SNR when the clipping ratio is 1.2. The curves also show that the BER of the clipped signal is 0.0019 for the same clipping ratio and SNR.

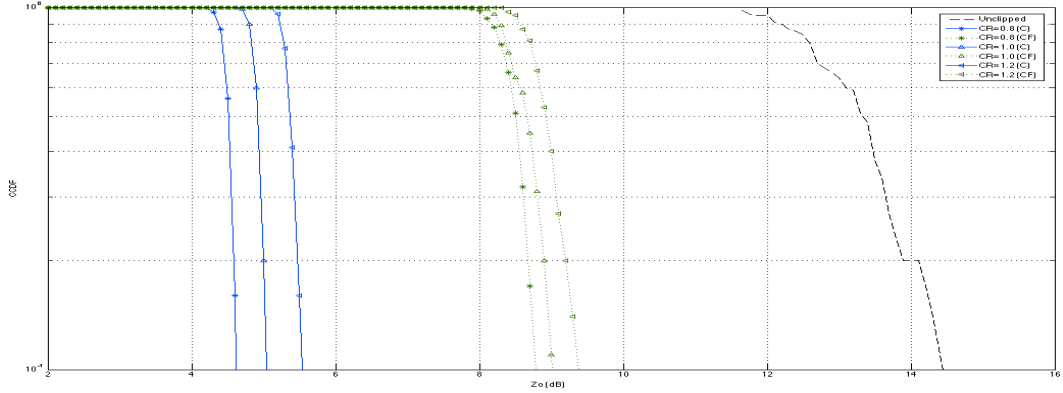

Fig9: PAPR distribution for clipped, filtered, and unclipped signals.

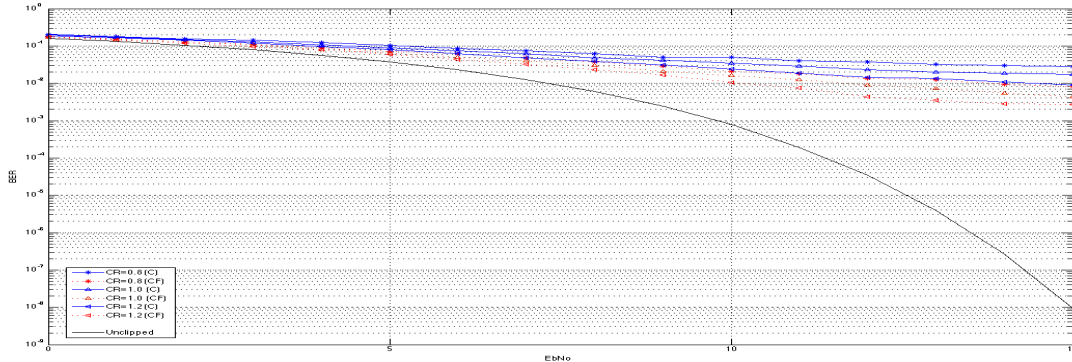

Fig10: BER for clipped, filtered, and unclipped signals.

VII. CONCLUSION

In this paper, the BER performance is investigated and analyzed for the OFDM and the single-carrier transmitting schemes to compare between them. For the both techniques, the same parameters are used to make a reasonable comparison and the two signals went through the same channel (AWGN). From the results, we have noticed that the BER performance is improved using the OFDM and outperforms the single-carrier performance. Though, there is a major drawback for using OFDM, which is the high PAPR. This problem can be reduced by using clipping and filtering, as a power reduction technique. The performance of clipping and filtering technique to has been studied in this paper. We conclude from our

results that PAPR reduces more at lower CR. The results show how clipping and filtering affect the BER of an OFDM signal and it is clear that the BER is increased after this process. Filter is used to decrease the distortion that result from clipping.

REFERENCES

- [1] A. John, Multicarrier Modulation for Data Transmission: An Idea Whose Time Has Come. *IEEE Communications Magazine*, 1990.
- [2] S. Albdran, A. Alshammari, and M. Matin, The Sensitivity of Bit Error Rate (BER) Performance in Multi-Carrier (OFDM) and Single-Carrier, *SPIE optics and photonics*, 2012.
- [3] J. Tubbax, OFDM versus Single Carrier: A Realistic Multi- Antenna Comparison, *EURASIP Journal on Applied Signal Processing*, 2004, 1275–1287.
- [4] R. Nee, and R. Prasad, OFDM for wireless multimedia communications, *Boston, MA: Artech House*, 2000.
- [5] Y. Cho, J. Kim, W. Yang, and C. Kang, *MIMO-OFDM wireless communication with MATLAB* (Singapore, Wiley, 2010)
- [6] A. Bahai, B. Saltzberg, and M. Ergen, Multi carrier digital communications: Theory and applications of OFDM, *Springer Science, New York*, 2004.
- [7] A. Saleh, R. Valenzuela, A Statistical Model for Indoor Multipath Propagation, *IEEE Journal on selected Areas in Communications*, 1987, 128-137.
- [8] H. Ochiai, and H. Imai, On the Distribution of the Peak to Average Power Ratio in OFDM Signals, *IEEE Trans. Commun*, 2001.
- [9] S. Han, and J. Lee, An overview of peak-to-average power ratio reduction techniques for multicarrier transmission, *IEEE Wireless Communications*, 2005, 56-65.
- [10] B. Alhasson, and M. Matin, Reduction of PAPR for OFDM Downlink and IFDMA Uplink Wireless Transmissions, *International Journal of Computer Science and Information Security*, 2011.
- [11] A. Alshammari, S. Albdran, M.Matin, Study of Bit Error Rate (BER) for Multicarrier OFDM, *SPIE optics and photonic*, 2012

Appendix B

(Conference Proceedings)

Study of Bit Error Rate (BER) for Multicarrier OFDM

Ahmed Alshammari, Saleh Albdran, and Mohammad Matin
Department of Electrical and Computer Engineering
School of Engineering and Computer Science
University of Denver

Abstract

Orthogonal Frequency Division Multiplexing (OFDM) is a multicarrier technique that is being used more and more in recent wideband digital communications. It is known for its ability to handle severe channel conditions, the efficiency of spectral usage and the high data rate. Therefore, It has been used in many wired and wireless communication systems such as DSL, wireless networks and 4G mobile communications. Data streams are modulated and sent over multiple subcarriers using either M-QAM or M-PSK. OFDM has lower inter symbol interference (ISI) levels because of the of the low data rates of carriers resulting in long symbol periods. In this paper, BER performance of OFDM with respect to signal to noise ratio (SNR) is evaluated. BPSK Modulation is used in s Simulation based system in order to get the BER over different wireless channels. These channels include additive white Gaussian Noise (AWGN) and fading channels that are based on Doppler spread and Delay spread. Plots of the results are compared with each other after varying some of the key parameters of the system such as the IFFT, number of carriers, SNR. The results of the simulation give visualization of what kind of BER to expect when the signal goes trough those channels.

Key Words: OFDM, BER, BPSK, SNR, ISI

1. INTRODUCTION

Nowadays data transmission at high bit rates is very important feature for many communication systems. The importance of this feature came from the development of communication system and the need for services like streaming video and digital audio. As a result, high bandwidth and low bit error ratio are two of the most important criteria for modern communication systems. High Speed data, voice signals, multimedia and video are all examples of the services offered by the latest generation of mobile communication systems. The Fourth Generation (4G) is one of the most capable schemes that can provide such serveries. 4G mainly utilize the principle of OFDM. These principles have been there since the 1960's [1][2]. Due to the lack of technology, it was not used for high-speed communication systems until the last decade. For example, very powerful processors were needed to carry on FFT and IFFT necessary for OFDM to work but such processors were not around for a long time when the principles of OFDM were in Theory. Also, linear power amplifiers and oscillators with enough stability to maintain subcarriers orthogonally were needed. By the 90's many of these obstacles were solved and since then OFDM has been getting more popular every year because of the many advantages it provides that solve conventional communication issues.

OFDM could be thought of as a particular case of FDM [2]. To understand that difference between FDM and OFDM, we could think of FDM and OFDM as the water coming from the faucet and the shower respectively. Therefore, the issue of ISI and fading effects on the signal are minimized as a result of transmitting the signal in parallel subcarriers with low data rate.

2. OFDM PARAMETERS

The communication channel bandwidth w is divided equally between the subcarriers. The width of each of one of the N subcarriers is $\Delta f = \frac{w}{N}$. The most essential factor in dividing the bandwidth is to achieve orthogonally between subcarriers. This can only be satisfied if the integral of multiplication of two subcarriers is zero for a particular time period. As shown by equation (1) It important to notice that any two sinusoids are orthogonal as long as their frequencies are integer multiples.

$$\int_0^T \cos(2\pi nft) \cos(2\pi mft) dt = 0 \quad (n \neq m) \quad (1)$$

Where n and m indicate the two integers, T is the period of the integration [10]. Also, the multicarrier signal is given as in equation (2)

$$s(t) = \sum_{m=-\infty}^{\infty} \left(\sum_{k=0}^{N-1} x_{k,m} \psi_k(t - mT_c) \right) \quad (2)$$

In the equation above the k^{th} subcarrier is modulated by the $x_{k,m}$ symbol.

The number subcarrier in any OFDM system is decided by two criteria. These two criteria are the size of IFFT and the channel bandwidth. IFFT size is decided fixed by the relation in equation (3). Increasing the number of subcarriers will result in decreasing ISI.

$$(number\ of\ subcarriers \leq \frac{IFFTsize}{2} - 2) \quad (3)$$

Subcarriers with a frequency of $f_k = k/T_{sym}$ are modulated by the symbol $X[k]$ for $N=6$ i.e. $k = 0,1,2 \dots 5$. Demodulation is carried out at the receiver utilizing the principle of orthogonality. N symbols in parallel compose the OFDM Symbol and it is important to know that the original length of the symbol $X[k]$ is extended from T_s to $T_s = NT_s$. This is due to transmitting N symbols simultaneously each of which modulates one of the orthogonal subcarriers.

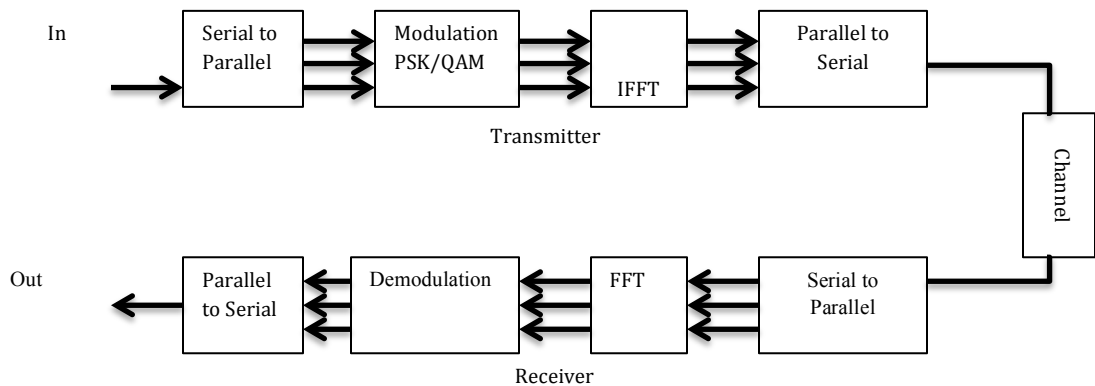

Figure 1 Block diagram of the OFDM system

3. OFDM SYSTEM MODEL

The OFDM system used in this paper is shown in figure 1. Reshaping data streams from series to parallel results in the blocks of data symbols to be transmitted. Assuming that N is the number of these blocks then OFDM symbols are characterized by $X_m = (x_{0,m} \ x_{1,m} \ \dots \ x_{N-1,m})^T$. After that each one of the symbols modulates one subcarrier. A guard band of length N_{cp} is attached to each OFDM symbol. The m^{th} OFDM symbol is given by equation (4).

$$S_m(n) = \begin{cases} \frac{1}{N} \sum_{k=0}^{N-1} x_{k,m} e^{\frac{j2\pi k(n-N_{cp})}{N}} & \text{for } n \in [0, N + N_{cp} - 1] \\ 0 & \text{otherwise} \end{cases} \quad (4)$$

Envelope detector detects the beginning and the end of each frame. Every frame is demodulated to data. Equation (5) represents the received signal $r(n)$ [6]. It is clear that the received signal is nothing but the summations of the white Gaussian noise (AWGN) $n(n)$ and the convolution of the channel's impulse response $h(n)$.

$$r(n) = \sum_{\eta}^{n_{cp}-1} h(\eta) s(n - \eta) + n(n) \quad (5)$$

4. COMMUNICATION CHANNEL

Communication channel means the path that the signal takes between the transmitter and the receiver. There are many forms of that according to the type of communication system. Additive noise and attenuated version of the signal are used to represent the channel in wireless communication systems. The loss in the signal as it approaches the receiving side is manifested by random attenuation while noise is there to represent other interference.

4.1 Fading

In wireless communication, signal might take two or more paths to get to the receiver. This phenomenon is called multipath propagation, which is usually caused, by atmospheric ducting, ionosphere reflection and refraction. Multipath propagation effects on the signal include phase shifting, constructive and destructive interference [5].

Overlapping that result from receiving copies of the transmitted signal at various times is the simplest definition of fading. Therefore, the received signal could have different amplitude and phase because of the propagation time and the intensity distribution of the waves [9].

4.2 Small Scale Fading

Nature of the sent signal and the channel are controls the kind of fading. Symbol duration, Bandwidth and channel parameter are all things that decide the quality of the channel. Doppler spread, RMS and delay spread usually cause four types of fading.

4.2.1 Fading Du To Delay Spread

Delay spread consists of two types [9]

- 1) Flat fading: Flat fading is the most popular kinds of fading. When the signal bandwidth is smaller than the bandwidth of the channel, Flat fading happens. The strength of the signal gets affected by this fading due to the gain variation of the channel while the spectrum remains the same.
- 2) Frequency Selective Fading: Linear phase response and constant gain are the main characteristics of frequency selective fading. The bandwidth of the channel is smaller than that of the signal. Signal is distorted by frequency selective fading due to the multiple version of the signal with various amplitudes and delay. In other word, frequency selective fading in mobile communication occurs as a result of the time dispersion of the transmitted signal.

4.2.2 Fading From Doppler Spread

Slow and fast fading results from Doppler spread. The fading is either slow or fast depending on the speed of the receiver.

- 1) Slow Fading: Symbol period is greater than coherence time in this case. Also, signal changes slower than the channel, which means that variations of the signal are faster than the channel's impulse response
- 2) Fast Fading: Impulse response of the channel variations are very fast through the symbol period i.e. symbol duration of the transmitted signal is greater than the coherence time of the channel

4.4 Communication Channel Model

Filtering properties of the channel is modeled by means of its time varying impulse response. Movement of the mobile is variable that influence time change. Received signal $y(d, t)$ is given by equation (6).

$$y(d, t) = \int_{-\infty}^t x(\tau)h(d, t - \tau)d(\tau) \quad (6)$$

Where $h(d, t)$ is the impulse response of the channel and $x(t)$ is the signal.

Knowing that the position of the receiver is $d = vt$ and knowing that v is just a constant, we could replace d in equation (6) with vt as in equation (7). As a result, mobile radio channels could be expressed as a linear time varying.

$$y(vt, t) = \int_{-\infty}^t x(\tau)h(vt, t - \tau)d(\tau) \quad (7)$$

$$h_b(t, \tau) = \sum_{i=0}^{N-1} a_i(t, \tau)e^{j(2\pi f_c \tau_i(t) + \varphi_i(t, \tau))} \delta(\tau - \tau_i(t)) \quad (8)$$

Impulse response of the baseband channel is given by equation (8). Here, $a_i(t, \tau)$ are the amplitudes and $\tau_i(t)$ are the delays whereas $\theta_i(t, \tau) = 2\pi f_c \tau_i(t) + \varphi_i(t, \tau)$ represent phase shift in the i th component.

In case of time invariant channel, delay occurs in each multipath component of the channel. Impulse response is calculated by equation (9).

$$h_b(\tau) = \sum_{i=0}^{N-1} a_i(t, \tau) e^{j\theta_i(t, \tau)} \delta(\tau - \tau_i(t)) \quad (9)$$

4.5 Rayleigh Distribution

Rayleigh fading is used to statistically model the properties of a channel that experience multipath conditions. According to Rayleigh model, the changes to the power signal are unpredictable and it assumes that there is no direct path between transmitter and receiver. Therefore, it assumes more than one connection that signal travel through to the receiver. Power Density function PDF of Rayleigh distribution is shown in equation (10). It is the result of summation of the quadrature Gaussian noise and the in-phase noise. Therefore, the fading follows Rayleigh distribution pattern.

$$p(r) = \begin{cases} \frac{r}{\sigma^2} e^{-\frac{r^2}{2\sigma^2}} & 0 \leq r < \infty \\ 0 & r < 0 \end{cases} \quad (10)$$

4.5.1 Clarke's Model

Clarke's Model is one of a number of models that generates Rayleigh fading. It depends on the scattering principle to find statistical properties of the channel. Also, it assumes that the transmitter is fixed that has a vertical polarized antenna. N azimuthally plane waves of the antenna with random carrier phases and angles of arrival are assumed while amplitude remains unchanged. Receiver mobility is assumed for flat fading and m_{th} wave that has arriving angle α_m with respect to the x-axis the Doppler shift is given by equation (11).

$$f_m = \frac{v}{\lambda} \cos \alpha_m \quad (11)$$

Where, λ is the wavelength of incident wave.

The spectrum is limited by $\pm f_m$ with a center frequency that is equal to the carrier frequency f_c . Every received wave in this case has a different carrier frequency with a small shift from the center frequency. The power spectral density of the output is given by equation 3.14. It is clear from that equation that the PDF is zero when $|f - f_c| > f_m$.

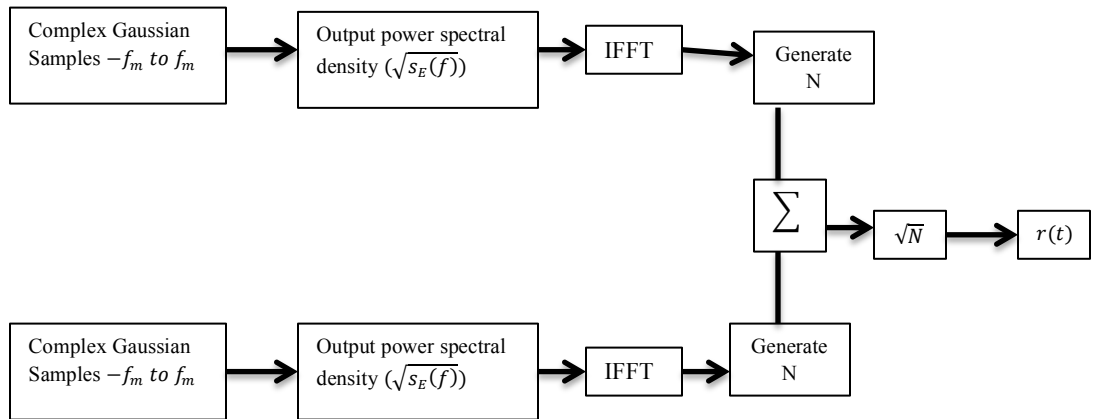

Figure 3 Rayleigh fading implementation

Spectrum is bounded by $\pm f_m$ and f_c the carrier frequency is the center frequency. Carrier frequencies are different for every wave. Equation (12) is the PDF of the received signal is $S(f)$ in equation (12)

$$S(f) = \frac{A[q(\alpha)G(\alpha)+(-\alpha)G(-\alpha)]}{f_n \sqrt{1-\left(\frac{f-f_c}{f_m}\right)^2}} \quad (12)$$

Assuming a vertical $\frac{\lambda}{4}$ antenna, $G(\alpha) = 1.5$ and $p(\alpha) = \frac{1}{2\pi}$ over 0 to 180° , then $S(f)$ becomes as in equation (13).

$$S(f) = \frac{1.5}{\pi f_m \sqrt{1-\left(\frac{f-f_c}{f_m}\right)^2}} \quad (13)$$

PDF of Doppler components arriving between 0 and π are infinite. However, the probability that one component reaches the receiver within these angles is zero because α is uniformly distributed.

Frequency Domain Rayleigh Fading is simulated according to the block diagram in figure 3. The signal goes through In-phase & quadrature modulation first. Therefore, Two independent Gaussian low pass noise sources are used to generate In-phase and quadrature fading components. IFFT is implemented as the last step in the simulator to shape the random signal

5. RESULTS

As discussed in the previous sections, OFDM technique as applied to a wireless communication in order to examine its performance. The signal is transmitted in MATLAB program over AWGN and fading Channels with various SNRs. The OFDM system is simulated according to the Model illustrated in the first section of this paper. Clarke's model has been utilized to implant the system over fading channels. Mobility of the receiver is one specification for this model. It was assumed the mobile is either moving slowly with a speed of 3 miles/hour or fast with a speed of 100 miles/hour in order to implement flat fading and frequency selective fading. Clarke's model assumes that there is no line of sight between the mobile and the transmitter because it depends on the principle of Rayleigh distributions. Figure 4 Shows the BER over AWGN channel with BPSK as the modulation technique. At the same values of SNR, AWGN has shown the best BER performance after that come both of flat fading channels as in figures 5&6 and frequency selective fading in figures 7&8 respectively. It is also noticed that increasing the speed of the receiver negatively affects the quality of the received signal.

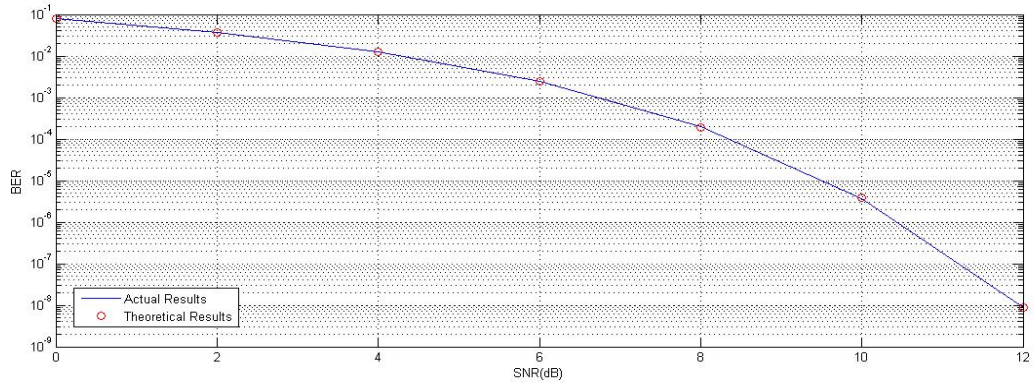

Figure 4 Shows the BER over AWGN

3 Miles/hour was assigned as the speed of the receiver for the purpose of simulating Small Doppler Spread and 100 Miles/hour was used to simulate large Doppler Spread. Figures 5 and 6 shows BER over Flat slow Fading and Flat Fast Fading respectively.

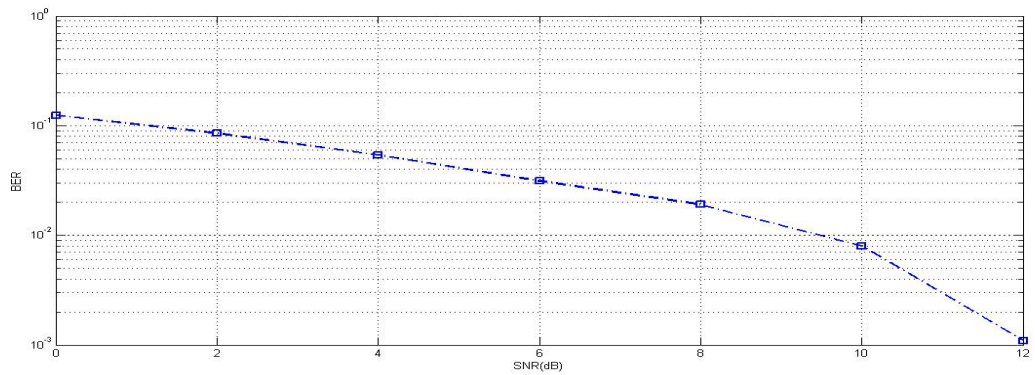

Figure 5 BER over Flat Slow Fading

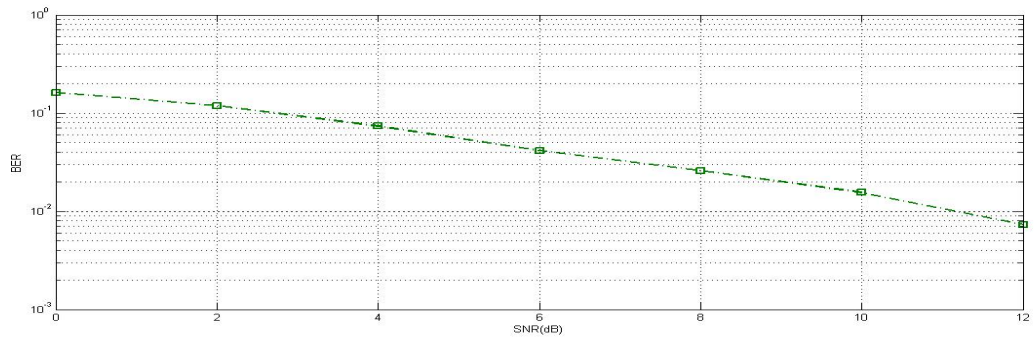
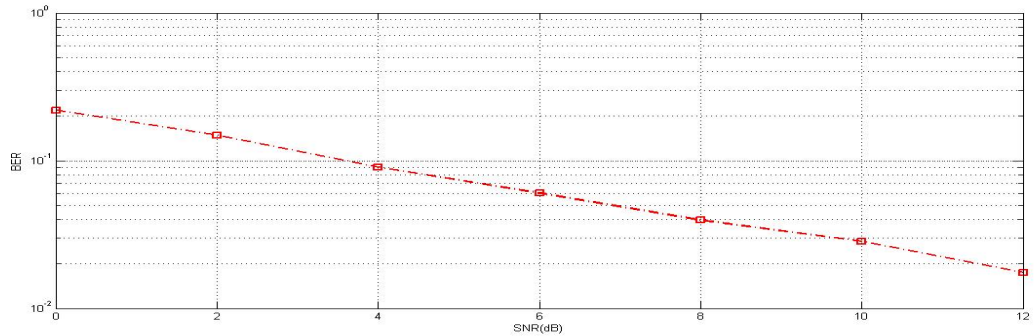

Figure 6 BER over Flat Fast Fading

In the Case of Frequency selective fading, Multiple Clarke's model is used. Different Delayed versions of the received signal are subjected to Clark's model to simulate frequency selective Fading. 4 different paths are assumed with delay of 0,4,8 and 16 samples. 3 Mile/hour mobile speed is used to simulate Frequency Selective Slow Fading and 100 Mile/hour speed is used to simulate Frequency Selective Fast Fading. Figures 7 and 8 shows BER over Frequency Selective Slow Fading and Frequency Selective Fast Fading respectively.



Figures 7 BER over Frequency Selective Slow Fading

BER of the four kinds of Fading are shown in figure 9. It is clear that the quality of the signal received from frequency selective fading channel is less than the one received from Flat Fading. Also, the quality of the received signal is less when the mobile is moving with higher speeds.

6. CONCLUSION

Effects of different wireless channels have been investigated in this paper. Results shows that AWGN Channel has the best performance while the results of flat fading and frequency selective fading indicates that they are of less efficient respectively. BPSK was used as the modulation technique for the purpose of studying the performance of OFDM. Also, Clarke's model was implemented to simulate the multipath channel environment. Fading Channels are very common in wireless communications. Therefore, Transmitting signals over fading channels cause a lot of problems to the process. Results show that the quality of the received signal is less when the mobile is moving with higher speed.

This research could be extended study to aspects of OFDM. For example, QAM could be used instead of MPSK modulation and compare outputs of both modulation techniques together. Also, it is possible to extend this research to the Multiple Input Multiple Output OFDM (MIMO-OFDM) Channels. MIMO is especially used for the purpose of wideband transmission after its combination with OFDM.

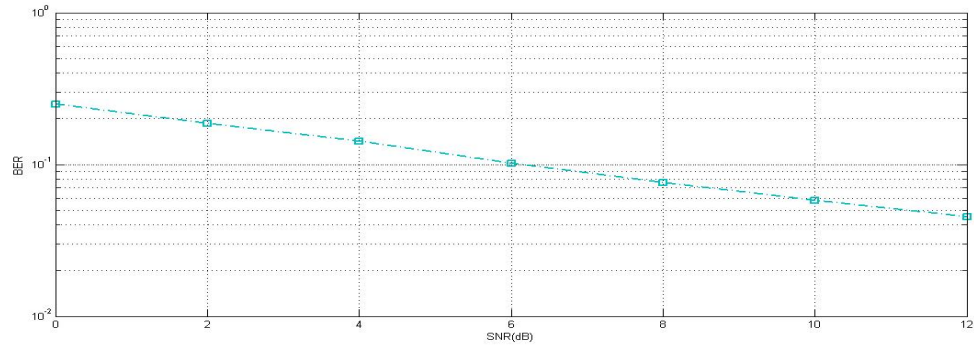

Figures 8 BER over Frequency Selective Fast Fading

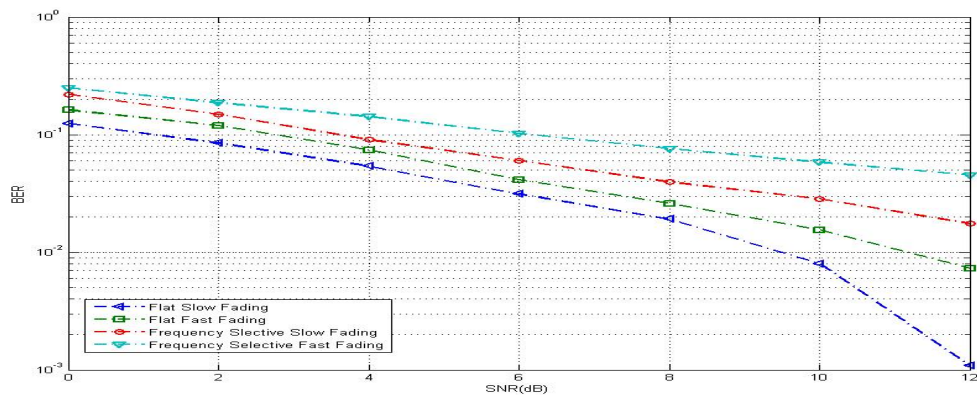

Figure 9 Comparing BER of The Different Channels

REFERENCES

- [1] BBC Research Department, E. D. "An Introduction to Digital Modulation And OFDM Techniques". (1993).
- [2] Cho, Y., Kim, J., Yang, W., & Kang, C. [MIMO-OFDM wireless communication with MATLAB. Singapore: Wiley]. (2010).
- [3] R. Frederiksen, F.B & Prasad, "An overview of OFDM and related techniques towards development of future wireless multimedia communications," in *IEEE*, 2002.
- [4] J. C. Chuang, "The Effects of Time Delay Spread on Portable Radio Communications Channels with Digital Modulation," *IEEE journal on selected areas in communications*, no. 5, 1987.
- [5] Communication, W., Spring, T., Mathur, S., & Engineering, E. Small Scale Fading in Radio Propagation. (2005).
- [6] Engels, M. [Wireless OFDM systems 2]. (2nd Ed.). Boston: KLUWE Academic. (2002).
- [7] Gayatri, S., Prabhu, P., & Shankar, M. (n.d.). "Simulation of Flat Fading Using MATLAB for Classroom Instruction". *IEEE TRANSACTIONS ON EDUCATION*.
- [8] Jeyasri, V. "Mobile Communications". India: Technical Publications Pune. (2009).
- [9] Rappaport, T. "Wireless Communication". Upper Saddle River, NJ: Prentice Hall. (1996).
- [10] SANKAR, K. Understanding an OFDM transmission. (2008). Retrieved April 15, 2012, from <http://www.dsplog.com/2008/02/03/understanding-an-ofdm-transmission>
- [11] Bloul A., Mohseni S., Alhasan B., Ayad M., and Matin M. A. "Simulation of OFDM technique for wireless communication systems", *Proc. SPIE*, Vol. 7797, 77971B, (2010), [DOI:10.1117/12.863101]

Study the Sensitivity of Bit Error Rate (BER) Performance in Multi-Carrier (OFDM) and Single-Carrier

Saleh Albdran, Ahmed Alshammari, Mohammed Matin.
Department of Electrical and Computer Engineering
University of Denver

Abstract

Recently, the single-carrier and multi-carrier transmissions have grabbed the attention of industrial systems. Theoretically, OFDM as a Multicarrier has more advantages over the Single-Carrier especially for high data rate. In this paper we will show which one of the two techniques outperforms the other. We will study and compare the performance of BER for both techniques for a given channel. As a function of signal to noise ratio SNR, the BER will be measure and studied. Also, Peak-to-Average Power Ratio (PAPR) is going to be examined and presented as a drawback of using OFDM. To make a reasonable comparison between the both techniques, we will use additive white Gaussian noise (AWGN) as a communication channel.

Key words: Single-Carrier (SC), Multi-Carrier, OFDM, BER, SNR, high data rate, Additive White Gaussian Noise (AWGN), IFFT, FFT.

1. Introduction

During the last decade, the wireless communications have been improved rapidly and as a result of that, the demand on the wireless communication devices have growth as well. The nature of the wireless channel, that is unpredictable, leads to more difficulties of calculating its noise and the propagation. Unlike the wireless channels, the wired one has less complexity of determining the noise due to the fixed path that the signal propagates through. There are several reasons for the signal to have degradation and one of them is called AWGN, which caused by either natural or industrial sources. Also, there is another common source called multipath fading, which is classified among the small-scale fading category. The reason to have this kind of fading is the natural or even industrial huge surfaces where the signal is reflected or scatted while it should ideally propagate directly to the receiver in case of not having obstacles.

The use of single-carrier transmission scheme provides easiness and accuracy while using low data rate. This type of transmission scheme has it own advantages and disadvantages. The single-carrier transmission is simple in case of having a flat fading channel also there is no need to increase the bandwidth of the signal by inserting a guard interval, unlike the multi-carrier technique. On the other hand, the single-carrier transmission has several drawbacks for instance, the complexity of equalizing which increases proportionally with the data rate. Another disadvantage is the suffering of Inter Simple Interference (ISI) that occurs when there is a multipath fading in the wireless channel or equivalently if the signal propagates through a frequency-selective fading channel.

In the case of having high data rate, the use of single-carrier might have several shortages and to overcome these problems, OFDM technique, as multi-carrier transmission, is proposed to transmit the signals [1]. The use of OFDM has several advantages; one of them is the high bandwidth efficiency while transmitting a large number of subcarriers. Also it is useful to use the multi-carrier scheme to overcome the ISI problems that occurred during the multipath or frequency-selective fading channels. Despite the

advantages, this scheme has its own drawbacks such as having low bandwidth efficiency for a small number of subcarrier or having high peak values due to the use of IFFT and the addition of many subcarrier components. OFDM has IFFT in the transmitting side and FFT in the receiving side. Before converting the data from series to parallel, a modulation technique such as phase shift keying PSK and quadrature amplitude modulation QAM will be applied to the signal [2]. The same thing will be done to the receiving side to demodulate the signal.

2. Single-Carrier Transmission

A typical end-to-end single-carrier transmission system is shown in Figure.1. This configuration consists of a band-limited channel $h(t)$, the transmit mapper $g_T(t)$, the receiver de-mapper $g_R(t)$ and equalizer $h^{-1}(t)$. The transmitted symbols are denoted by a_n , each one of these symbols has a period of T and data rate of $R = 1/T$. The following equations shows the equalizer output where the additive noise is denoted by $z(t)$ and the other one shows the impulse response for the whole system which is denoted by:

$$y(t) = \sum_{m=-\infty}^{\infty} a_m g(t - mT) + z(t) \quad (1)$$

$$g(t) = g_T(t) * h(t) * g_R(t) * h^{-1}(t) \quad (2)$$

In this paper we assume that the signal is completely recovered from the channel effect using the equalizer. As a result of this assumption, we ignore the noise in the previous equation of the equalizer output and the noise-free equation can be represented as follow:

$$y(t) = \sum_{m=-\infty}^{\infty} a_m g((n - m)T) \quad (3)$$



Figure1: Model of single-carrier transmission system.

In the mapping and de-mapping stages, two different modulation techniques are used. The amplitude modulation is represented by QAM and the binary modulation is demonstrated by PSK. To clarify the idea behind these procedures, we will go through the PSK and explain its concept. The input signal usually has a sinusoidal shape and it can be mapped into another form where $I(t)$ denotes the In-phase component and $Q(t)$ denotes the Quadrature component. In the case of using Binary Phase Shift Keying (BPSK) as a modulation type, we would have two possible values, either 0 or 1. On the other hand, the QPSK would have four possible values, two binary digits at a time, (00,01,10,11) and the following table shows how to represent them in terms of Q and I:

Binary Digits	I(t)	Q(t)
00	$1/\sqrt{2}$	$1/\sqrt{2}$
01	$1/\sqrt{2}$	$-1/\sqrt{2}$
10	$-1/\sqrt{2}$	$1/\sqrt{2}$
11	$-1/\sqrt{2}$	$-1/\sqrt{2}$

Table 1: Converting binary digits to complex form.

3. Multi-Carrier Transmission (OFDM)

OFDM is used as a multi-carrier transmission scheme to overcome the shortages and the problems that appear during the single-carrier transmission [4]. The block diagram of the OFDM transmission scheme is shown in Figure.2 and it has two main parts: transmitter and receiver. Mainly, the transmitter has a mapper where the signal is modulated there by either digital or analog modulation technique. As mentioned in the previous section, MPSK modulation technique is going to be used in this paper with different order numbers. After mapping the signal, a serial to parallel conversion is applied to the signal to make shorter sequences with lower number of symbols. Pilot insertion is used in this scheme by fitting reserved sub-carrier in between the sub-carrier that carried information. The point of inserting these pilots is to estimate the start of the OFDM symbol on the receiving side also to make equal distribution for the noise over the entire signal. To create OFDM symbols we need a way to solve the problem of using of huge number of RF oscillator. To overcome this issue, the inverse Discrete Fourier Transform can be applied to generate the OFDM symbols and to speed up the process, FFT can be used.

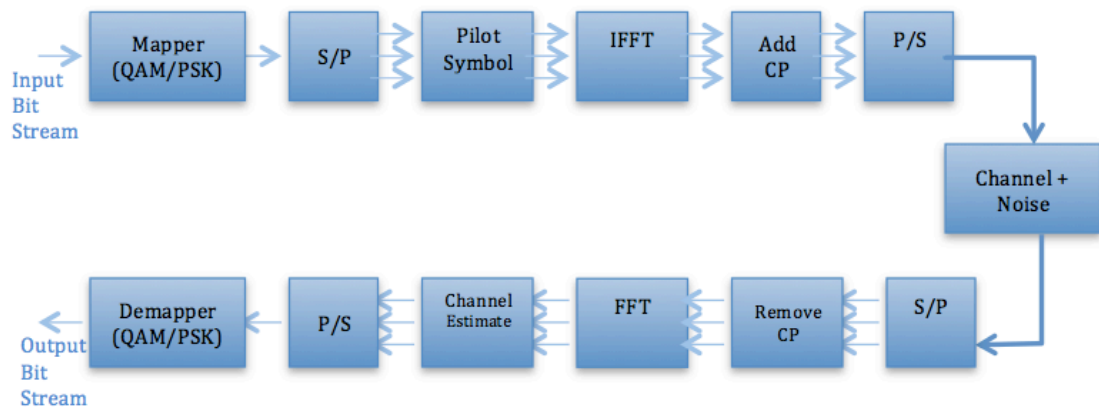

Figure2: Model of Multi-carrier transmission system (OFDM).

Orthogonality must be maintained to insure better spectral efficiency and maximum capacity. The reason of applying orthogonality is to keep the center of the subcarrier from being overlapped and letting the spectrums of the subcarriers overlapping to get higher efficiency of the spectral. Assume we are having

complex exponential signal $\{e^{j2\pi f_k t}\}_{k=0}^{N-1}$ that represents the subcarriers in the OFDM signal where $f_k = k/T_{sym}$. To check whether any two sub-carriers in the OFDM signal are maintaining the orthogonality or not, we can apply the following conditions in equation (4):

$$\begin{aligned} \frac{1}{T_{sym}} \int_0^{T_{sym}} e^{j2\pi f_k t} e^{-j2\pi f_i t} dt &= \frac{1}{T_{sym}} \int_0^{T_{sym}} e^{\frac{j2\pi k}{T_{sym}} t} e^{-\frac{j2\pi i}{T_{sym}} t} dt \\ &= \frac{1}{T_{sym}} \int_0^{T_{sym}} e^{\frac{j2\pi(k-i)}{T_{sym}} t} dt \\ &= \begin{cases} 1, & \text{when } k = i \\ 0, & \text{otherwise} \end{cases} \end{aligned} \quad (4)$$

Where if the dot product of the two signals is equal to zero we can say that the two signals are orthogonal to each other. This term of orthogonality is so useful in terms of preventing interfering in the carriers and avoiding Inter Carrier Interference (ICI). We can express the previous equation in the discrete time domain at $t = nT_s = \frac{nT_{sym}}{N}$, and the value of n goes from 0 to N-1 as equation (5) shows:

$$\begin{aligned} \frac{1}{N} \sum_{n=0}^{N-1} e^{\frac{j2\pi k}{T_{sym}} nT_s} e^{-\frac{j2\pi i}{T_{sym}} nT_s} &= \frac{1}{N} \sum_{n=0}^{N-1} e^{\frac{j2\pi k}{T_{sym}} nT/N} e^{-\frac{j2\pi i}{T_{sym}} nT/N} = \\ &= \frac{1}{N} \sum_{n=0}^{N-1} e^{\frac{j2\pi(k-i)}{N} n} \\ &= \begin{cases} 1, & \text{when } k = i \\ 0, & \text{otherwise} \end{cases} \end{aligned} \quad (5)$$

To avoid Inter Symbol Interference (ISI), guard intervals are inserted in between the OFDM symbols avoiding the overlapping between the symbols due to the delay in one of the transmitted symbols. The use of guard interval insures a full attenuation for the symbol and keeping the next symbol away. There are several ways to implement the concept of guard intervals insertion; one of them is the zero padding where the guard interval is nothing more than a null signal. The other two techniques are similar to each other and called cyclic prefix (CP) and cyclic suffix (CS). In this paper CP is used to maintain the wanted preventio

against the ISI. In the CP technique, a cyclic extension is copied from the OFDM symbol and inserted at the front. The duration of the OFDM symbol T_{sub} is increased by the cyclic prefix duration T_G making the final duration of the OFDM symbol equals to T_{sym} as equation (6) shows:

$$T_{sym} = T_{sub} + T_G \quad (6)$$

The parallel OFDM symbols should be converted to serial symbols preparing the OFDM signal to be up-converted which is the last stage in the transmitting side. . The duration of the converted OFDM symbol, which is coming out of the parallel to serial convertor operation, is denoted by X_{len} , while the duration length of the OFDM symbol in the parallel form before proceeding through the convertor is equal to $T_{sub} + T_G$. Assuming that the number of OFDM symbols is denoted by M, we can apply the operation shows in equation (7) to find the duration of the of the converted OFDM symbol X_{len} as follow:

$$X_{len} = M(T_{sub} + T_G) \quad (7)$$

On the receiving side, the received signal is down converted to extract the base-band signal out of it by assuming that both of the receiver and the transmitter are in time synchronization. Then, the received signal converted from serial form to parallel form with shorter sequence length. After removing the cyclic prefix interval that are inserted in the transmitting side, the signal goes through the FFT operation to extract the sub-carriers values without using huge number of filters and oscillators. The output of the FFT operation is de-mapped using PSK modulation technique and this stage is the last one on the receiving side. If we have a perfect transmitter and receiver, we might have identical input and output, which is practically impossible. There are some reasons to not have perfect modulation scheme one of them is the errors of the residual equalization that cause mismatch between the transmitter and receiver in terms of phase shift and the value of the amplitude [5].

4. Noise and Channel Fading

The nature of the wireless channel affects the performance of the wireless system in a bad way. Unlike the wired communication systems, It is so difficult to do exact calculation for the noise and the propagation in the case of have wireless channels. These difficulties appear due to the randomness of the noise and the unpredictability of the channel propagation. Basically, there are two main sources for the system degradation: additive white Gaussian noise (AWGN) and multipath fading.

AWGN is undesirable signals that combined with the sent information making it so difficult for the receiver to extract the correct information. In that kind of noise, the data transmission rate will be affected negatively. There are different sources to have this kind of noise, which can be classified into two main categories: natural and industrial sources. Naturally, the sunray the atmospheric particles could cause AWGN and degrade the system performance. On the other hand, the overhead power lines, electrical and electronic devices and switches are example of industrial noise sources.

Assume we have a white Gaussian noise denoted by $w(t)$ which disturb the information signal $s(t)$, in that case we will have a received signal as follow:

$$r(t) = s(t) + w(t) \quad (8)$$

In radio signal, when the signals get to the antenna of the receiver from different paths it can be called multipath fading. The multipath fading could be caused by different reasons and might be formed in many

ways. Ideally, the signals propagate directly to the receiver in one path if there are no obstacles. But in reality, the natural huge objects like mountains could cause a shadowing or scattering for the signal due to its rough surface. The signals also could be reflected or diffracted because of buildings, trees or mountainsides [6].

5. Peak-to-Average Power Ratio (PAPR)

The way of calculation the PAPR depend on the ratio between the maximum power of the complex pass-band signal and the mean power of it. The following equation shows how to calculate the PAPR [7].

$$PAPR = \frac{\max(x^2(t))}{\text{mean}(x^2(t))} \quad (9)$$

Where the amplitude of the complex pass-band signal is denoted by $x(t)$. In the worst-case scenario by adding all the subcarriers, the OFDM peak power for N subcarriers equals to N. In M-QAM and M-PSK, we have noticed that the PAPR increases when the value of M goes up. When we have N goes to ∞ , the maximum PAPR for the signal x_k represented as follow:

$$PAPR_m = \frac{N}{N/N} = N \quad (10)$$

6. Simulation Results

Before going through the results of the BER performance, let us explain the definition of the BER. The bit error is the received bits coming through a communication channel and carried by a stream of data where these bets have been affected and changed by the nature of the communication channel. To calculate the bet error rate, the total number of the affected bits is divided by the entire amount of the transmitted bits during a specific time interval to get a unit-less quantity that is proposed as a percentage.

In the first part of the simulation results, AWGN channel is used as communication channel without including any fading effects. BER performance for the single-carrier transmission was simulated by generating a MATLAB code with M-PSK modulation type. Then, the same thing is done for multi-carrier transmission scheme (OFDM). After that, a comparison between the OFDM and the SC transmission techniques is presented in terms of BER performance and PAPR behavior using BPSK.

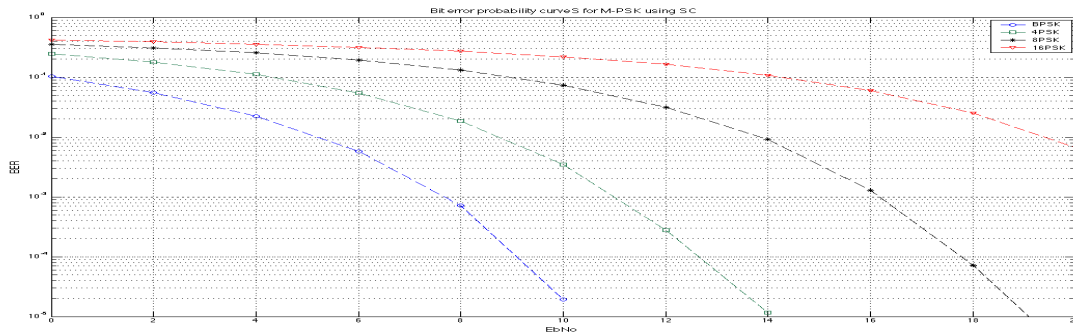

Figure 4: BER curves for SC using M-PSK

The BER performance is affected by the order of the modulation technique; the lower the order the best the performance. Figure 4 shows BER curves of single-carrier transmission using M-PSK with M= 2, 4, 8, and 16. The curves illustrates that the best BER performance occurs when BPSK is used.

The same thing is noticed when the OFDM scheme is used as shown in Figure 5. The 16-PSK modulation technique has the worst BER performance compared to the lower order.

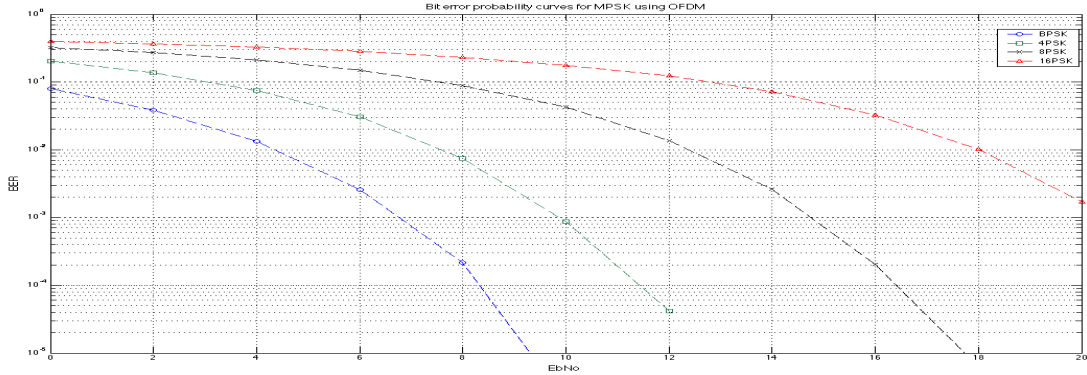

Figure 5: BER curves for OFDM using M-PSK.

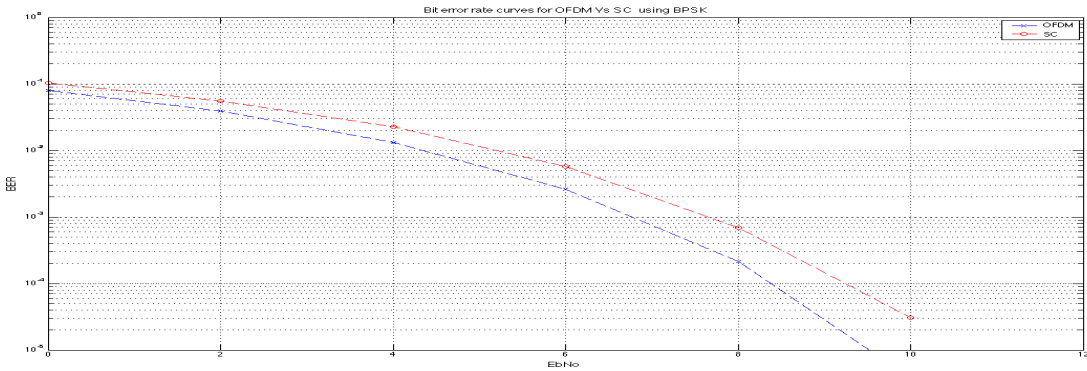

Figure 6: BER curves for OFDM Vs. SC using BPSK.

Figure 6 shows a comparison between OFDM and SC in terms of BER performance using BPSK and from the curves we can see that the use of OFDM reduces the BER percentage. From the SC curve we can indicate higher BER but on the other hand the PAPR distribution is much lower as shown in Figure 7. The red curve in Figure 7 represents the PAPR distribution for OFDM which much higher than the blue one which is for SC. The bad PAPR performance is a major drawback that it appears with OFDM.

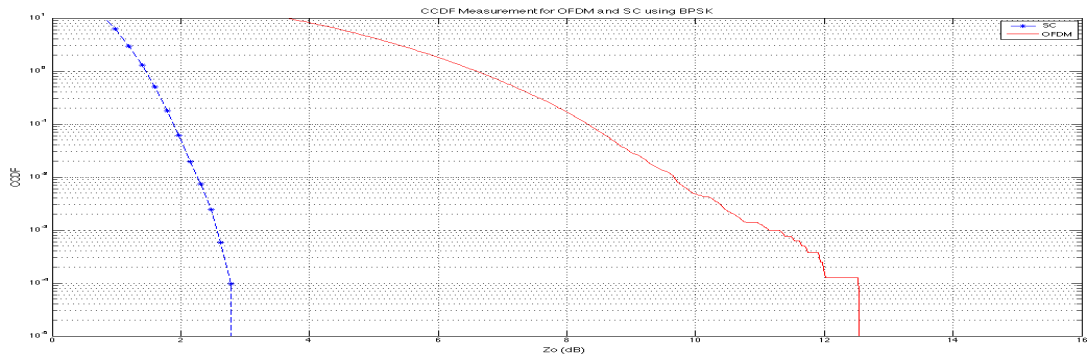

Figure 7: CCDFs of OFDM Vs. SC using BPSK.

7. Conclusion

In this paper, a comparison between multi-carrier and single-carrier systems is presented to study the BER performance. The transmitted data, in both cases, has the same parameters and the signal went through the same channel (AWGN) to make a reasonable comparison. The results showed for both techniques advantages and drawbacks.

From the results, we have noticed that the use of the OFDM transmission system improves the BER performance and outperforms the single-carrier scheme. On the other hand, the OFDM scheme has a main drawback which is the high PAPR compared to the single-carrier. This problem can be dealt with using PAPR reduction techniques, which can be used to improve the performance of PAPR [8] [9].

References

- [1] Principle, H. E., Transmitting, O. F., & By, D. (1990). Multicarrier Modulation for Data Transmission : An Idea Whose Time Has Come. IEEE Communications Magazine, (May).
- [2] "Air Interface for Fixed Broadband Wireless Access Systems", IEEE Standard 802.16-2004, 2004.
- [3] J. Tubbax, et. al, " OFDM versus Single Carrier: A Realistic Multi- Antenna Comparison", EURASIP Journal on Applied Signal Processing 2004:9, 1275–1287_c 2004.
- [4] R. van Nee and R. Prasad, "OFDM for wireless multimedia communications," *Boston, MA: Artech House*, 2000.
- [5] A. Bahai, B. Saltzberg and M. Ergen, Multi carrier digital communications: Theory and applications of OFDM, Springer Science, New York, 2004.
- [6] SALEH, A., VALENZUELA, R., "A Statistical Model for Indoor Multipath Propagation", IEEE Journal on selected Areas in Communications, Volume 5, Issue 2, Feb 1987 Page(s):128 137
- [7] H. Ochiai and H. Imai, On the Distribution of the Peak to Average Power Ratio in OFDM Signals, IEEE Trans. Commun., vol. 49, no. 2, pp. 28289, Feb. 2001.
- [8] S. H. Han and J. H. Lee, "An overview of peak-to-average power ratio reduction techniques for multicarrier transmission," IEEE Wireless Communications, vol. 12,
- [9] Alhasson B. and Matin M. A., "Reduction of PAPR for OFDM Downlink and IFDMA Uplink Wireless Transmissions", International Journal of Computer Science and Information Security, Vol. 9, No. 3, pp 6-13, 2011, ISSN: 1947-5