

University of Denver

Digital Commons @ DU

Electronic Theses and Dissertations

Graduate Studies

1-1-2012

The Bit Error Rate (BER) Performance in Multi-Carrier (OFDM) and Single-Carrier

Saleh M. Albdran
University of Denver

Follow this and additional works at: <https://digitalcommons.du.edu/etd>



Part of the [Electrical and Electronics Commons](#)

Recommended Citation

Albdran, Saleh M., "The Bit Error Rate (BER) Performance in Multi-Carrier (OFDM) and Single-Carrier" (2012). *Electronic Theses and Dissertations*. 744.
<https://digitalcommons.du.edu/etd/744>

This Thesis is brought to you for free and open access by the Graduate Studies at Digital Commons @ DU. It has been accepted for inclusion in Electronic Theses and Dissertations by an authorized administrator of Digital Commons @ DU. For more information, please contact jennifer.cox@du.edu, dig-commons@du.edu.

THE BIT ERROR RATE (BER) PERFORMANCE IN MULTI-CARRIER (OFDM)
AND SINGLE-CARRIER

A Thesis

Presented to

The Faculty of Engineering and Computer Science

University of Denver

In Partial Fulfillment

of the Requirements for the Degree

Master of Science

by

Saleh Albdran

November 2012

Advisor: Dr. Mohammed Matin

© Copyright by Saleh Mohammad Albdran 2012

All Rights Reserved

Author: Saleh Albdran
Title: THE BIT ERROR RATE (BER) PERFORMANCE IN MULTI-CARRIER (OFDM) AND SINGLE-CARRIER
Advisor: Dr. Mohammad Matin
Degree Date: November 2012

Abstract

The spectacular growth of wireless communication tools has escalated the number of mobile subscribers from almost 700 million in 2000 to more than 4 billion in 2009. The huge number of subscribers has led to several issues with how service is provided. The high user demand has forced developers to overcome the problems of the old analog systems and to introduce OFDM as a promising technique that can fulfill users' high demands. This technique matches well with high data rate connection and provides a higher capacity for the subscribers' usage.

The OFDM, as a multi-carrier, is more complex than the single-carrier transmission scheme. However, the OFDM technique maintains better performance for high data rate in terms of bit error rate (BER). In this thesis a comparison has been presented between the multi-carrier OFDM and the single-carrier to prove, in a simulation form, the theoretical point of view. Despite the advantages of using the OFDM scheme, there are several drawbacks. One of these negatives is the high peak to average power ratio (PAPR).

To overcome this problem, there are power reduction techniques that can be applied to the signal to reduce the high power. One of these techniques is the clipping and filtering technique. A maximum level is sited for the transmitted signal to reduce the power and afterward, the signal goes through a filter to remove the influence of the in-band distortion and out-of-band radiation.

Acknowledgment

This thesis report could not have been done without the help of my supervisor, Dr. Mohammad Matin, who supported and encouraged me during my master's program from the first day we met until the last page of this report was written. He did his best to push me to my limits. I also extend my acknowledgment and gratitude to Dr. David Gao and Dr. Vi Narapareddy for their advice and corrections.

Special thanks go to my parents who supported me throughout my long journey. Also, I would like to express my gratitude towards my wife for everything she has done for me.

Table of Contents

Abstract	ii
Acknowledgements	iii
Abbreviations	vi
List of Figures	viii
List of Tables	x
Chapter 1: Introduction	1
1.1 History of Communication Systems	2
1.2 Propagation and Fading of Wireless Channels	3
1.2.1 AWGN	3
1.2.2 Multipath Fading.....	3
1.3 OFDM.....	4
1.4 Single-Carrier Transmission.....	5
1.5 Problem Statement.....	6
1.6 Scope of Research Work	7
1.7 Methodology	7
Chapter 2: Orthogonal Frequency Division Multiplexing.....	9
2.1 OFDM Overview	9
2.2 History of OFDM.....	10
2.3 OFDM Modulation	11
2.3.1 Constellation	12
2.3.2 Symbol Mapping.....	14
2.3.3 Serial to Parallel Conversion	15
2.3.3.1 Symbol Interleaving	16
2.3.4 Pilot Insertion	16
2.3.5 Inverse Fast Fourier Transform	17
2.3.5.1 Orthogonality	18
2.3.6 OFDM Guard Interval	19
2.3.6.1 Cyclic Prefix (CP).....	20
2.3.7 Parallel to Serial Conversion	21
2.3.8 Up-Conversion	21
2.4 OFDM Demodulation	22
2.4.1 Serial to Parallel Conversion	22
2.4.2 Guard Period Removal	22
2.4.3 Fast Fourier Transform	23

2.4.4 Equalization and Channel Estimation	24
2.4.4.1 Equalization	24
2.4.4.2 Channel Estimation	25
2.4.5 Parallel to Serial Conversion	25
2.4.6 Symbol Demodulation	25
Chapter 3: PAPR Reduction Techniques	27
3.1 PAPR Overview	27
3.2 PAPR Reduction Techniques	30
3.2.1 Clipping Technique	31
3.2.2 Clipping and Filtering	32
3.2.3 Partial Transmit Sequence (PTS) Technique	33
Chapter 4: Simulation Results	35
4.1 M-PSK Comparison for SC and OFDM	36
4.2 Comparison Between OFDM and SC	39
4.3 PAPR Reduction Using Clipping and Filtering	43
4.4 Results Evaluation	50
Chapter 5: Conclusion and Future Work	52
5.1 Conclusion	52
5.2 Future Work	53
Reference	55
Appendix A: Journal Publications	59
Appendix B: Conference Proceedings	74

Abbreviations

AWGN “Additive White Gaussian Noise”

BER “Bit Error Rate”

BPSK “Binary Phase Shift Keying”

CCDF “Complementary Cumulative Distribution Function”

CDF “Cumulative Distribution Function”

CP “Cyclic Prefix”

CR “Cognitive Radio”

DFT “Discrete Fourier Transform”

ETSI “European Telecommunications Standards Institute”

FDM “Frequency Division Multiplexing”

FFT “Fast Fourier Transform”

GSM “Global System for Mobile Communication”

ICI “Inter Carrier Interference”

IDFT “Inverse Discrete Fourier Transform”

IFFT “Inverse Fast Fourier Transform”

ISI “Inter Symbol Interference”

LAN “Local Area Network”

LTE “Long Term Evolution”

OFDM “Orthogonal Frequency Division Multiplexing”

PAPR “Peak to Average Power Ratio”

PSK “Phase Shift Keying”

PTS “Partial Transmit Sequences”

QAM “Quadrature Amplitude Modulation”

QPSK “Quadrature Phase Shift Keying”

RF “Radio Frequency”

SISO “Single Input Single Output SIMO Single Input Multiple Outputs”

SNR “Signal to Noise Ratio”

TDMA “Time Division Multiplexing Access”

Wi-Fi “Wireless Fidelity”

WiMAX “Worldwide Interoperability for Microwave Access”

WLAN “Wireless Local Area Network”

List of Figures

Figure 1.1: Multipath-Fading.....	4
Figure 1.2: Model of Single-carrier Transmission System	6
Figure 1.3: Thesis Flow Chart	8
Figure 2.1: OFDM Block Diagram.....	11
Figure 2.2: Constellation of QPSK with 45° Phase Shift	12
Figure 2.3: Constellation of 8-PSK.....	13
Figure 2.4: Constellation of 16-QAM.....	13
Figure 2.5: Serial to Parallel Conversion.....	15
Figure 2.6: Pilot Sub-carrier Insertion	16
Figure 2.7: Power Spectrum of OFDM Signal with Four-carriers	19
Figure 2.8: OFDM Symbol with CP of Length T_G	20
Figure 2.9: Guard Period Removal	23
Figure 3.1: Input and Output Characteristic of an HPA	29
Figure 3.2: The Block Diagram of Clipping and Filtering Technique for PAPR.....	31
Figure 4.1: BER Curves for SC using M-PSK	36
Figure 4.2: BER Curves for OFDM using M-PSK.....	37
Figure 4.3: CCDF Measurements for Single-Carrier using M-PSK.....	38
Figure 4.4: CCDF Measurements for Multi-Carrier using M-PSK	38
Figure 4.5: BER Curves for OFDM Vs. SC using BPSK.....	39
Figure 4.6: CCDFs of OFDM Vs. SC using BPSK	40
Figure 4.7: BER Curves for OFDM Vs. SC using 4QAM	41
Figure 4.8: CCDFs of OFDM Vs. SC using 4QAM.....	41

Figure 4.9: BER Curves for OFDM Vs. SC using 8PSK	42
Figure 4.10: CCDFs of OFDM Vs. SC using 8PSK.....	43
Figure 4.11: Baseband Signal after adding CP	45
Figure 4.12: Power Spectrum of the Pass-band Signal	45
Figure 4.13: Power Spectrum of Clipped Signal	46
Figure 4.14: Power Spectrum of the Clipped Signal	46
Figure 4.15: PAPR Distribution for Clipped and Unclipped Signals	47
Figure 4.16: BER for Clipped and Unclipped Signals.....	48
Figure 4.17: PAPR Distribution for Clipped, Filtered, and Unclipped Signals.....	49
Figure 4.18: BER for Clipped, Filtered, and Unclipped Signals	49
Figure 5.1: Block Diagram for Clipped-PTS Technique	54

List of Tables

Table 2.1: I and Q components for one binary digit	14
Table 2.2: I and Q components for two binary digits	15
Table 4.1: Parameters used for simulation.....	43
Table 4.2: Comparison between OFDM and SC	50
Table 4.3: Comparison between clipped, filtered, and unclipped signals	51

Chapter One: Introduction

During the last few years wireless communication has grown rapidly and the demand on this new tool of interaction has increased because of its ease of use and its portability. This report is made up of five chapters. Chapter 1 includes a brief history of wireless communication, specifically the history of the OFDM, which also proposes the problems and presents the methodology.

Chapter 2 has a detailed explanation of the OFDM procedure. It also illustrates the different stages of the transmitter and the receiver. Chapter 3 includes general information about PAPR definition and how we can reduce power use through various reduction techniques, such as the clipping technique and the clipping and filtering technique. Also, in the same chapter Partial Transmit Sequence (PTS), another power reduction method, is discussed in detail. The simulation results of my thesis are proposed in Chapter 4 and plans for future work conclude this report in Chapter 5.

1.1 History of Wireless Communication Systems

The early 1990's could be named the era of new digital communications, starting with the huge success of the internet, which coordinated with the rising popularity of mobile devices. In the 1980's, the very first communication systems of analog mobiles were established and the era of cellular phones started officially. Because of the competition between developers, each country had its own system. In 1979, Nippon Telephone and Telegraph (NTT) started a new mobile communication system in Japan and five years later Motorola developed a system in the United Kingdom named Total Access Communication System (TACS). A few years later, Norway, Germany and France established their own mobile communication systems with different standards.

These analog systems could not provide enough capacity to deal with users' high demand [33]. Additionally, the mismatch between the diverse systems made it difficult to start a real global industry. In 1990, a new standard (IS-54B) was developed in North America and the capacity of the system was increased by using Time Division Multiplexing Access (TDMA). Two years later, a new system had been developed called Global System for Mobile Communications (GSM).

Because of the fast growth of the internet, new wireless standards were developed to provide the mobile users with an internet service [1]. The first communication system that provided internet service is the third generation (3G) [28]. This kind of phone supported both indoor and outdoor applications with speeds of up to 384kbps and 2Mbps respectively. The Long Term Evolution (LTE) [36] or 4GPP communication systems recently revealed offer both extremely fast internet connection (compared to 3G) and a reasonable price for IP based services [17].

1.2 Propagation and Fading of Wireless Channels

The environment of the wireless channel plays a basic role affecting the performance of the system. The unpredictability of the wireless channel makes it difficult to perform an exact calculation of the noise and its propagation compared to the fixed and predictable noise measurements in the wired channels. Mainly, Additive White Gaussian Noise (AWGN) and multipath fading are the most common sources for these systems' performance degradation.

1.2.1 AWGN

The AWGN is an unwanted signal. When combined with the main information being sent, the receiver has difficulty getting and extracting the main information from the AWGN. AWGN sources can be classified into two main groups: natural or industrial. Natural sources include sunrays and atmospheric particles. On the other hand, industrial sources could be overhead power lines, electronic devices and switches.

1.2.2 Multipath Fading

Multipath fading occurs when the receiver antenna receives different signals from different paths [21]. Multipath fading could be formed in many ways by various causes as shown in Figure 1. In the ideal situation, the signal should propagate directly to the antenna with no obstacles. However, in real applications, natural huge objects such as a mountain could cause shadowing or scattering of the signal due to the mountain's rough surface [30]. The signal could also be reflected or diffracted because of buildings or trees [2].

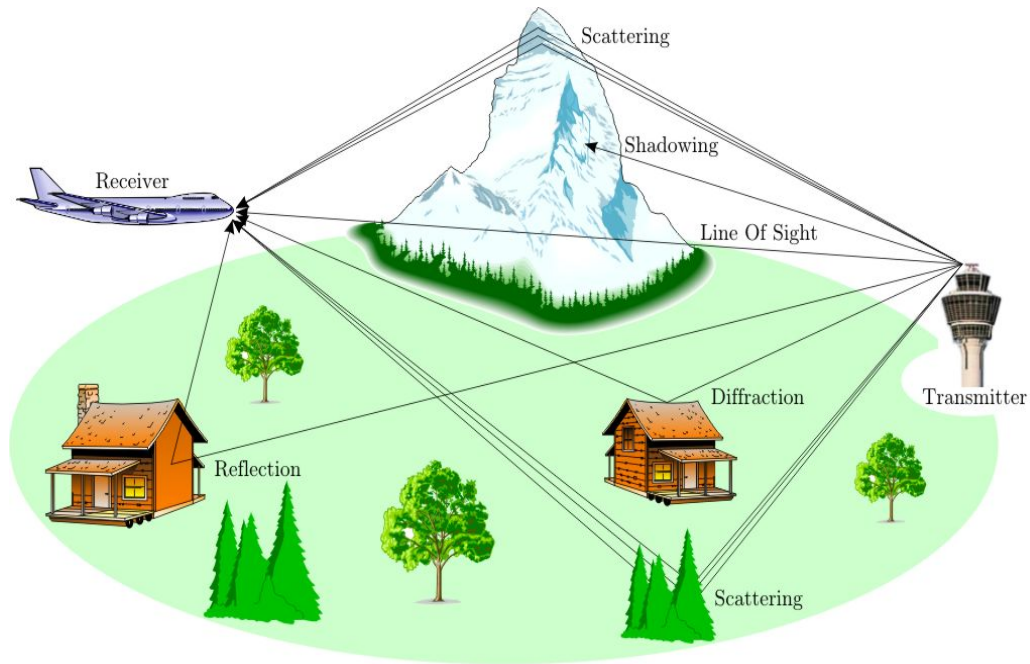

Figure1.1: Multipath Fading [3]

1.3 OFDM

Recently, the OFDM scheme is becoming an extremely popular multicarrier technique for communication systems. The fact that OFDM is much less exposed to the effects of multipath fading makes it the main communication technique for future standards [11]. OFDM is also less complex than other techniques, reducing the multipath fading effect without using complex equalizers.

The idea of transmitting data in parallel form was first developed in the 1960's and named Frequency Division Multiplexing (FDM). Despite the advantages of this technique, its spectral efficiency is poor and each sub-channel must be modulated individually. In the OFDM technique, the high data rate stream is divided into N subcarriers that have a smaller data rate. The overlapping between sub-channels is applied and the subcarriers must be orthogonal to each other.

In the early 1990's, OFDM was used in certain wireless standards like Asymmetric Digital Subscriber Loop (ADSL). Several years later, European and Japanese standards used OFDM in their Digital Terrestrial Video Broadcasting (DTVB)[4]. Recently, new standards such as Broadband Fixed Wireless Access (BFWA) and Wireless Metropolitan Area Network (WMAN) and other standards have begun using OFDM [5].

1.4 Single-Carrier Transmission

A typical end-to-end single-carrier transmission scheme is shown in Figure 1.2. This block diagram represents a transmission system with a band-limited channel denoted by $h(t)$, and a transmitted mapper represented by $g_T(t)$. While the receiver de-mapper signal is denoted by $g_R(t)$, and $h^{-1}(t)$ represents the output of the equalizer. We assume that a_n is a transmitted signal with a symbol period of T and the data rate is calculated as $R = 1/T$. The output of transmission system is shown in equations (1.1) and (1.2) where the signal goes through AWGN channel $z(t)$:

$$y(t) = \sum_{m=-\infty}^{\infty} a_m g(t - mT) + z(t) \quad (1.1)$$

$$g(t) = g_T(t) * h(t) * g_R(t) * h^{-1}(t) \quad (1.2)$$

It is assumed in this thesis that the transmitted signal has recovered completely from the effects of fading and noise using the equalizer. Due to this assumption, the noise that is in the previous equations is ignored and the output, that is free of noise, is represented as follow:

$$y(t) = \sum_{m=-\infty}^{\infty} a_m g((n - m)T) \quad (1.3)$$

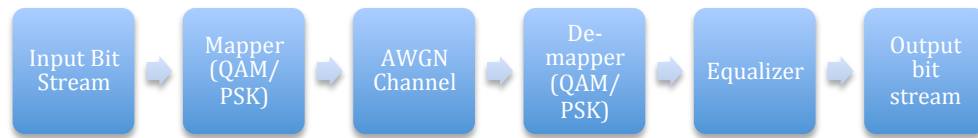

Fig1.2: Model of Single-carrier Transmission System

In the mapping and de-mapping stages, different modulation techniques could be used [45]. QAM and PSK are used in this thesis as a modulation technique [18]. The input sinusoidal signal can be mapped to two components: the in-phase component $I(t)$ and the quadrature component $Q(t)$. To explain the concept of modulation procedure, Binary PSK can be used as an example. In the case of having BPSK, there are two possible values, 0 or 1. While, if QPSK is used, we would have two binary digits at a time (00, 01, 10, 11).

1.5 Problem Statement

The single-carrier transmission scheme has its own advantages; but in terms of high data rate, the single-carrier has channel estimation complexity. Also, the BER performance with the single-carrier is less than OFDM. The real issue with the single-carrier scheme is Inter-Symbol Interference (ISI) when a multi-path fading channel is present. Using OFDM for transmission is the best way to avoid fading problems and to improve the BER performance. In the case of using the OFDM transmission system, there are some serious drawbacks. One of these problems is the high PAPR performance. In this thesis a power reduction technique, which is clipping and filtering technique, is used to improve the PAPR performance.

1.6 Scope of Research Work

A multi-carrier transmission scheme such as OFDM could be used to overcome the issues that appear when using the single-carrier transmission scheme. A study of Bit Error Rate (BER) performance is proposed to present a comparison between the OFDM and the single-carrier transmission schemes in different situations. The most significant drawback of the OFDM scheme is the high PAPR performance. A clipping technique can be applied to the signal for reducing the power but this technique has some disadvantages such as radiation and distortion. To overcome these disadvantages, the clipped signal should be filtered to reduce the effects of distortion and radiation by trading off a higher PAPR.

1.7 Methodology

The MATLAB simulation program is used to build models of single-carrier and multi-carrier communication schemes in order to study their respective BER performance. By plotting BER graphs we can make a reasonable comparison between the two techniques, which are useful in showing how badly the noise in the channel affects the signal. Also, simulating the power reduction technique schemes allows us to examine how the power is reduced. The following figure represents a flow chart for the thesis report.

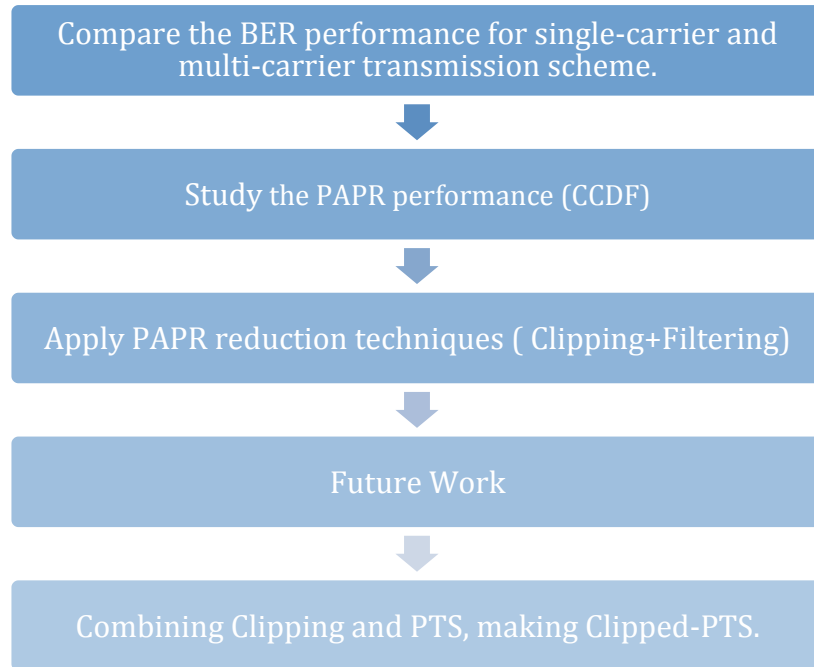

Figure 1.3: Thesis Flow Chart

Chapter Two: Orthogonal Frequency Division Multiplexing

In this thesis I am focusing on OFDM as a modulation technique that is a multi-carrier for high data rate transmission. This chapter starts with an overview describing OFDM in Section 2.1. Also, there is background information on OFDM starting with the beginning of the invention followed by a history of the development process up to the present in Section 2.2. Section 2.3 presents a detailed explanation of OFDM modulation including symbol mapping, pilot insertion, IFFT, and other stages of the modulation process [20]. The demodulation process is described in Section 2.4, including the main stages required for receiving an OFDM signal.

2.1 OFDM Overview

OFDM is a multicarrier scheme with the ability of supporting high data transmission rates and providing more efficient performance compared to single-carrier transmission systems. Because of the effective use of multiple frequencies in transmitting data, OFDM uses the Radio Frequency (RF) spectrum more efficiently. OFDM has one more advantage over the single-carrier technique, the ease of the signal equalization process. To achieve the system's orthogonality, guard intervals must be applied to the OFDM transmission process. The drawback of using guard interval is lower spectral efficiency [6]. The OFDM scheme is becoming popular because of its ability to transmit high data-rate. Besides, the idea of orthogonality provides a good use of channel bandwidth[19].

2.2 History of OFDM

Multi-carrier modulation was first used by Kineplex Collins in the 1950's when they produced a voice band modem with 3000 bps [7]. In 1966, Chang and Saltzberg of Bell Labs, which got the patent for OFDM, wrote the first paper about OFDM. At that time the idea of OFDM was only a theory and it proved very difficult to implement due to the huge amount of hardware requirements. In 1971, Weisten and Ebert proposed a solution to reduce the number of hardware components by using Fast Fourier Transform (FFT) and inserting guard intervals.

In 1980, OFDM appeared in telephone line transmissions because it offered increased FFT efficiency and reduced the complexity of the process. Five years later, OFDM was proposed for use in mobile communications and in the scheme of digital broadcasting. That proposal was completed in 1989 by Rault and Castellian, who developed a solution to mobile communications problems by using OFDM in conjunction with codes of convolution, and their method became the main transmission technique in the standards of digital audio broadcasting.

OFDM's performance was examined by Bingham in 1990. He investigated the sensitivity BER versus fixed values of signal to noise ratio (SNR) over a no distortion wireless channel. Another study was conducted to determine how to develop the performance of the OFDM system using different techniques. In 1997, the European Telecommunications Standards Institute (ETSI) released its new OFDM-based standards for Digital Video Broadcasting-Terrestrial (DVB-T). OFDM-based schemes are also used in North American standards like IEEE802.11a and IEEE802.11g [32].

2.3 OFDM Modulation

There are different ways to modulate and demodulate the message bits using OFDM transceiver [35]. The simplest way to build an OFDM transmitter and receiver is presented in Figure 2.1. In the block diagram of the OFDM transceiver, there are two main parts: the transmitter and the receiver. In this section, before going through the details of the different stages of the transmitter and receiver, an important term - “data symbol” - should be explained clearly. It is a complex-value number on the constellation diagram in two dimensions and is represented as a dot [25].

The process in the transmitter includes mapping using either QAM or PSK. After converting serial streams to parallel, the signal goes through IFFT operation. Then, a guard period is inserted to prevent information overlapping and the signal to be sent through a wireless channel is then prepared by applying a parallel to serial convertor.

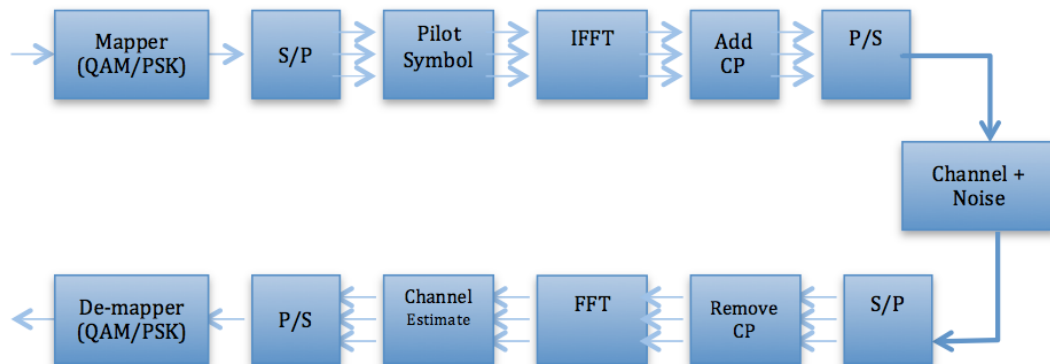

Figure 2.1: OFDM Block Diagram

On the receiving side, the series signal will be converted to parallel to remove the cyclic prefix. Afterwards, a FFT will be applied to the signal before the estimating stage using the channel estimator. To demodulate the signal using either QAM demodulator or PSK modulator, a parallel to serial converter is applied.

2.3.1 Constellation

A data symbol is correlated to a two-dimensional diagram that is called a constellation diagram and the data symbol is shown on the diagram as a point. To map the modulated signal, the data symbol is represented as complex-value number on the constellation diagram in two dimensions. The imaginary part of the data symbol is represented by y-axis with the origin of $0i$ and the x-axis represents the real part with origin of 0 as well. The format of the constellation diagram depends on the type of modulation. If QPSK is used then there will be four signal points on the diagram as shown in Figure 2.2. Figure 2.3 and Figure 2.4 present 8-PSK and 16-QAM constellation diagrams respectively.

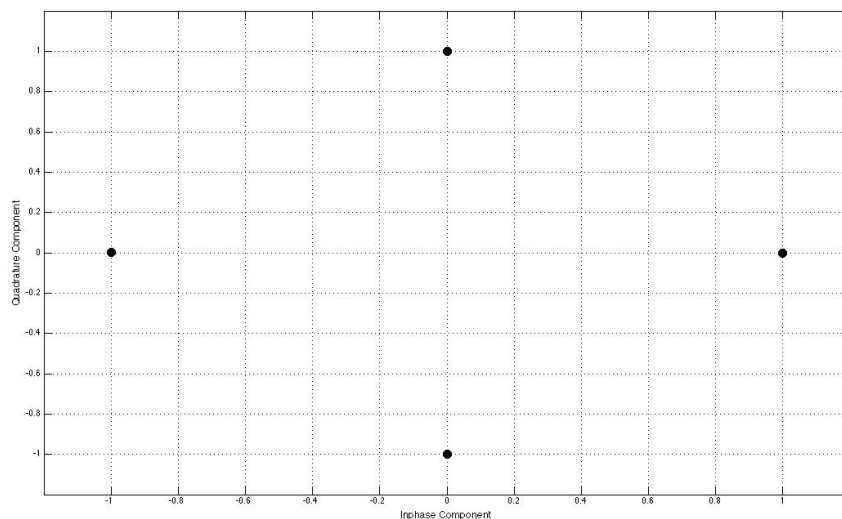

Fig 2.2: Constellation of QPSK with 45° Phase Shift

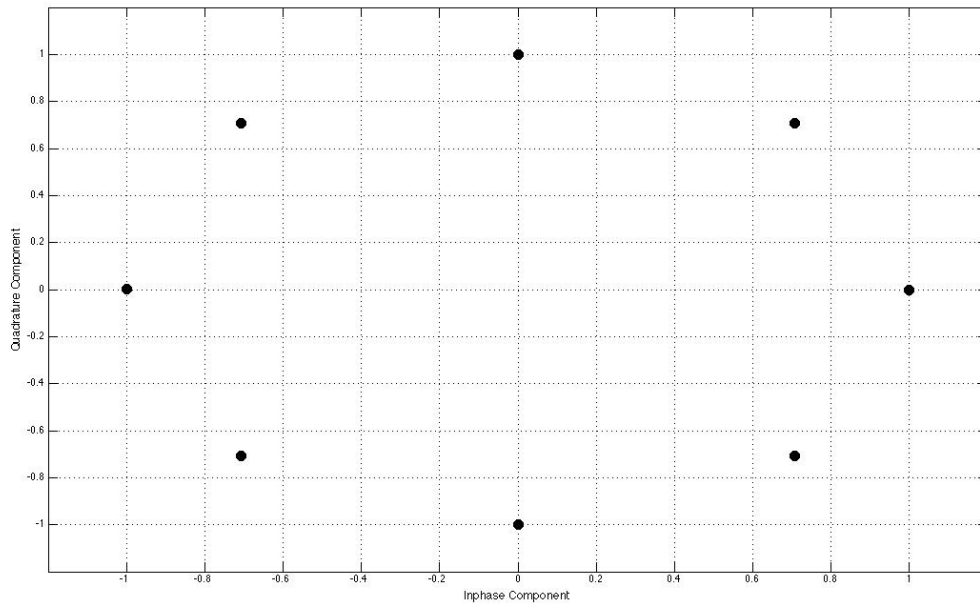

Fig 2.3: Constellation of 8-PSK

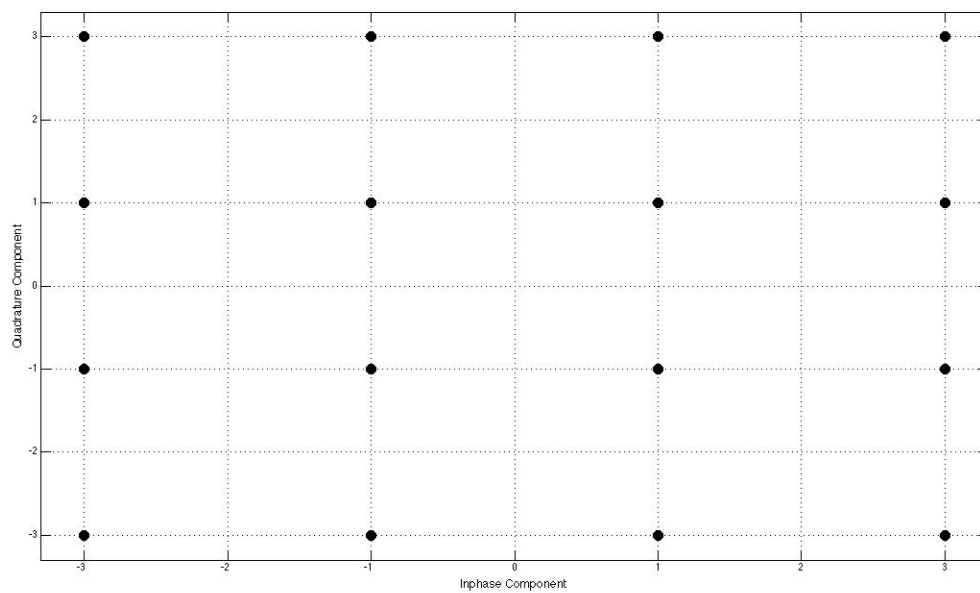

Fig 2.4: Constellation of 16-QAM

2.3.2 Symbol Mapping

In the OFDM transceiver, we usually have a sinusoidal signal as a basic function and we can represent that signal with frequency of f_n , number of subcarrier of n , and amplitude of $A(t)$ as follows:

$$\phi_n(t) = A(t)\exp(j2\pi f_n t) \quad 2.1$$

The previous equation 2.1 can be represented in another form where $I(t)$ denotes the in-phase component and $Q(t)$ denotes the Quadrature component:

$$\phi_n(t) = A(t) \cos(2\pi f_n t) + A(t)j\sin(2\pi f_n t) = I(t) + jQ(t) \quad 2.2$$

The data of the input signal is represented in phase and amplitude form and carried by the sub-carriers. To clarify the idea, examine a Binary Phase Shift Keying (BPSK) as a modulation type. Since it is binary, it has one binary value each time, meaning we have only two possible values, either 0 or 1. These values in terms of Q and it would be represented as follows:

Binary Digits	I(t)	jQ(t)
0	1	0
1	-1	0

Table 2.1: I and Q Components for One Binary Digit.

The same thing could be shown using QPSK where there are two binary values at a time (00, 01, 10, 11). These binary values could be represented in a complex form in the expressions of in-phase and Quadrature values as listed in table 2.2.

Binary Digits	I(t)	Q(t)
00	$1/\sqrt{2}$	$1/\sqrt{2}$
01	$1/\sqrt{2}$	$-1/\sqrt{2}$
10	$-1/\sqrt{2}$	$1/\sqrt{2}$
11	$-1/\sqrt{2}$	$-1/\sqrt{2}$

Table 2.2: I and Q Components for Two Binary Digits

2.3.3 Serial to Parallel Conversion

When binary values are converted to complex values, the sequence of data signals should be converted to parallel symbols. These parallel symbols must be arranged into sub-sets and, depending on the number of the sub-carriers, we can determine how many data symbols will be carried in each sub-set. In Figure 2.5, presume that there are sixteen signal points of complex-value to be transmitted by eight sub-carriers; simply, each sub-carrier should carry two data symbols. To rearrange the data symbols, we should start with the last two symbols and place them into the eighth sub-carrier. Then the same step is performed on all of the data symbols until we assign the first two symbols to the first sub-carrier.

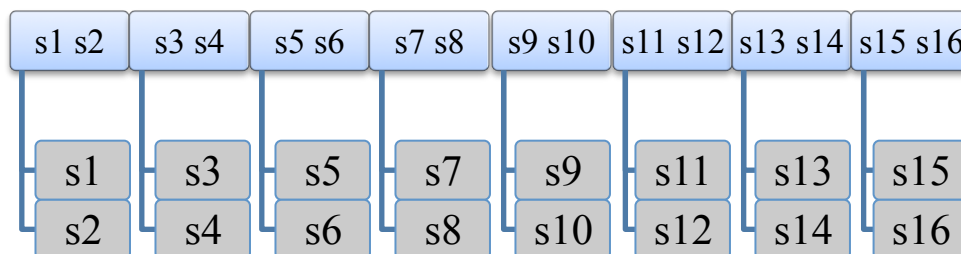

Figure 2.5: Serial to Parallel Conversion.

2.3.3.1 Symbol Interleaving

To ensure a well transmitted signal with lower fading effects, we should use symbol interleaving. This is a means of rearranging the position of the signals, unlike the original signal form, to get average fading effects over the entire transmitted signal. The advantage of using symbol interleaving is that it offers the chance to save most of the sequence and keep the loss to one symbol at each sequence. This prevents extensive damage to most of the symbols in one sequence, which would require investing valuable time to correct.

2.3.4 Pilot Insertion

The pilot carriers are reserved sub-carriers inserted in between the sub-carriers that carry information. One advantage of pilot insertion is that it equalizes channel noise over the entire signal. It is also important to insert pilot sub-carriers to estimate the beginning of the OFDM symbol on the receiving side. One option for pilot insertion is shown in Figure 2.6, where two OFDM symbols are placed in parallel. Pilot insertion would increase the number of sub-carriers in Figure 2.5 from eight to fifteen sub-carriers.



Figure 2.6: Pilot Sub-carrier Insertion

2.3.5 Inverse Fast Fourier Transform

After inserting the pilot carriers, we must have a fast way to create OFDM symbols. We need one Radio Frequency (RF) oscillator in the single-carrier transceiver, one Radio Frequency (RF) oscillator, and, if we use the same technique in multi-carrier, a unique oscillator for each carrier. The problems of using an RF oscillator include RF-leakage due to the overlapping, and the close space between the oscillators. Also, it very difficult to maintain the orthogonality and keep any two adjacent signals orthogonal to each other. Finally, the complicated transceiver that is needed to create the OFDM symbols and the huge modulation components increase the complexity and forcing the developer to find ways to overcome those problems.

One suggestion for solving the complexity of the transceiver would be to calculate the inverse Discrete Fourier Transform (DFT) to generate OFDM symbols. DFT requires long and complicated computations to run it. The Fast Fourier Transform is proposed to speed up the process. Cooley and Tukey developed FFT algorithm in 1965 [8]. FFT and IFFT are both useful in OFDM transceivers to reduce the size of the physical components. The FFT algorithm is also suitable to ensure that we maintain the orthogonality in the OFDM transceiver and to avoid any interference. In the following subsection several important details describe and explain the idea of orthogonality and how to maintain and ensure that the signals are orthogonal to each other.

2.3.5.1 Orthogonality

To ensure maximum capacity and higher spectral efficiency in the system, orthogonality must be maintained. The point is to keep the center frequency of the sub-carrier from overlapping while the spectrums of the sub-carrier overlap to achieve higher spectral efficiency. By maintaining orthogonality the received signals do not suffer from any interference caused by the neighboring signal or any degradation in the signal.

Suppose that we have a complex exponential signal $\{e^{j2\pi f_k t}\}_{k=0}^{N-1}$ that denotes the subcarriers in the OFDM signal where $f_k = k/T_{sym}$. To investigate if any two subcarriers in the OFDM signal are orthogonal to each other or not, we should apply the orthogonality condition as follows:

$$\begin{aligned} \frac{1}{T_{sym}} \int_0^{T_{sym}} e^{j2\pi f_k t} e^{-j2\pi f_i t} dt &= \frac{1}{T_{sym}} \int_0^{T_{sym}} e^{\frac{j2\pi k}{T_{sym}} t} e^{-\frac{j2\pi i}{T_{sym}} t} dt \\ &= \frac{1}{T_{sym}} \int_0^{T_{sym}} e^{\frac{j2\pi(k-i)}{T_{sym}} t} dt = \begin{cases} 1, & \text{when } k = i \\ 0, & \text{otherwise} \end{cases} \end{aligned} \quad (2.3)$$

Where, if the dot product equals to zero, we can say that the two signals are orthogonal to each other. We can express the previous equation in the discrete time domain at $t = nT_s = \frac{nT_{sym}}{N}$, and the value of n goes from 0 to N-1.

$$\begin{aligned} \frac{1}{N} \sum_{n=0}^{N-1} e^{\frac{j2\pi k}{T_{sym}} nT_s} e^{-\frac{j2\pi i}{T_{sym}} nT_s} &= \frac{1}{N} \sum_{n=0}^{N-1} e^{\frac{j2\pi k}{T_{sym}} nT/N} e^{-\frac{j2\pi i}{T_{sym}} nT/N} = \\ &= \frac{1}{N} \sum_{n=0}^{N-1} e^{\frac{j2\pi(k-i)}{N} n} = \begin{cases} 1, & \text{when } k = i \\ 0, & \text{otherwise} \end{cases} \end{aligned} \quad (2.4)$$

This condition of orthogonality is vital for avoiding Inter Carrier Interference (ICI). The following Figure 2.7 illustrates power signals whose spectrums interfere with one another while their centers are spaced equally.

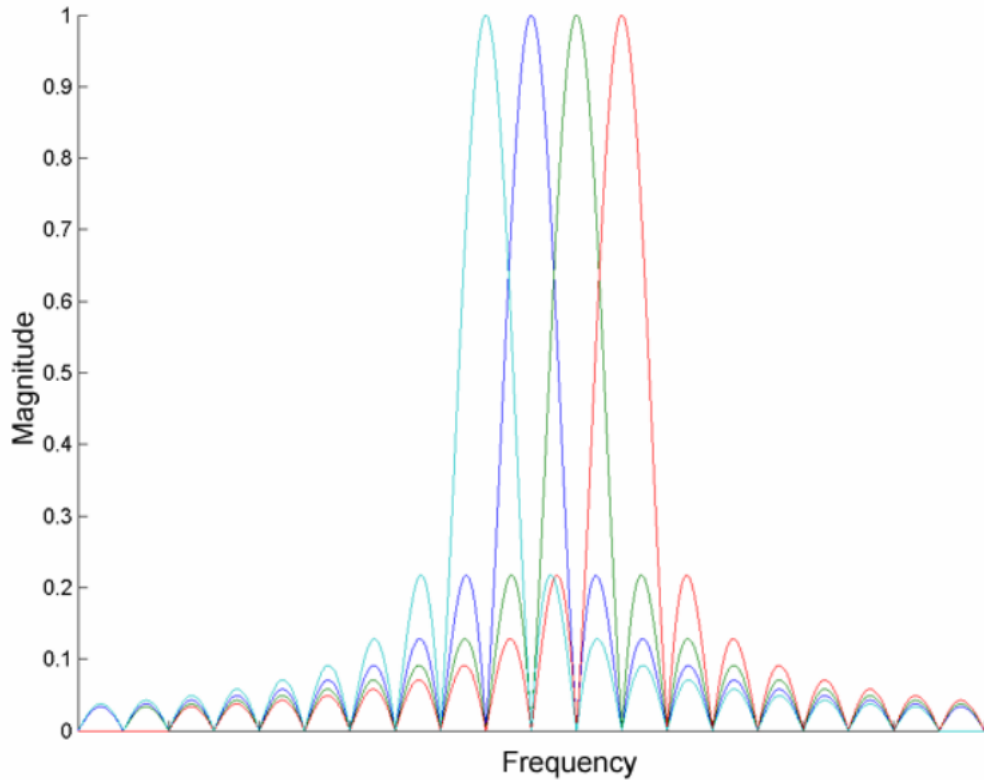

Figure 2.7: Power Spectrum of OFDM Signal with Four-carriers [27]

2.3.6 OFDM Guard Interval

To prevent ISI and thereby maintain orthogonality, it is important to insert guard intervals between the symbols of the OFDM signal. The occurrence of ISI is due to one or more delays in transmitted OFDM symbols causing symbols to interfere with the next transmitted OFDM symbol. The guard intervals ensure a period of protection keeping the transmitted symbol apart from the next symbol and preserving full attenuation for the previous one. The guard interval could be zero padding where there is a null signal

inserted between the OFDM symbols. Two other guard techniques include cyclic prefix and cyclic suffix. The cyclic prefix is an extra extension that is duplicated from the symbol end and inserted at the front of the symbol. Conversely, cyclic suffix is a copy of the OFDM symbol head that is inserted at the tail of the symbol.

2.3.6.1 Cyclic Prefix (CP)

CP is a method that can be applied to the signal for ISI effect reduction. This technique involves duplicating a cyclic extension and inserting it at the head of the symbol. The length of CP is denoted by T_G and the duration of the OFDM symbol becomes $T_{sym} = T_{sub} + T_G$. Figure 2.8 shows an OFDM symbol with a cyclic prefix that has a length of T_G inserted at the head of the symbol. To ensure a minimum effect of ISI, we should set the length of the CP longer or at least at the same length as the greatest multipath channel delay. If the CP duration is shorter than the multipath channel delay, the tail of the symbol would be affected by the head of the next one causing ISI.

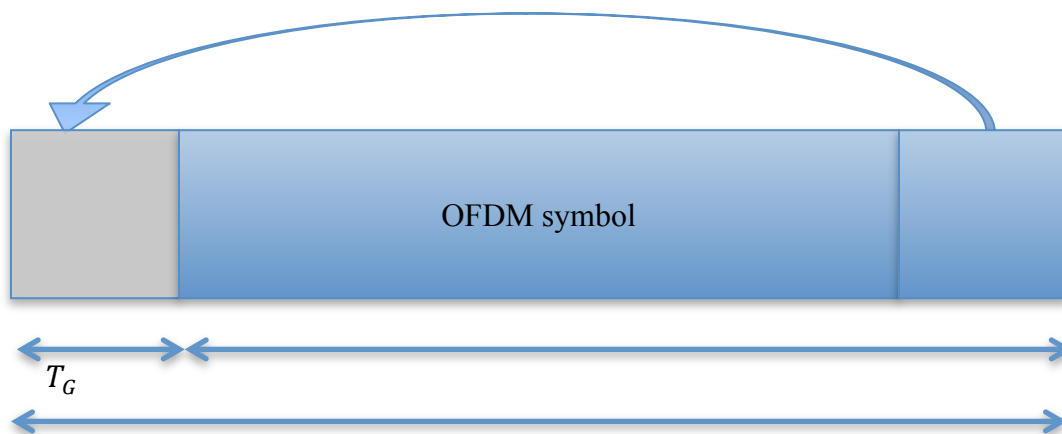

Figure 2.8: OFDM Symbol with CP of Length T_G

The FFT start point would cause a problem even if the CP duration is made longer than the multipath channel delay. ISI would happen if the FFT starting point comes ahead of the earlier symbol end. However, if the opposite happens, where both ISI and ICI could occur, the problem would be worse [38].

2.3.7 Parallel to Serial Conversion

After inserting the guard intervals, CP in this case, the parallel OFDM symbols are converted to serial OFDM. The outputs of this conversion are OFDM signals that are prepared for up-conversion. The length of the converted OFDM symbol is denoted by X_{len} , while the length of the OFDM symbol in the parallel form is equal to $T_{sub} + T_G$. If we have the number of OFDM symbols denoted by M , we can find the value of X_{len} as follows:

$$X_{len} = M(T_{sub} + T_G) \quad (2.5)$$

2.3.8 Up-Conversion

In terms of translating the frequency, the stage of converting the baseband OFDM signal to the desired band is the last stage in the transmitter. In this stage, there is a combination of the baseband signal and RF signal. It is at this point that the desired center frequency of the pass-band signal is chosen. To fulfill international standards, a spectrum mask is used for windowing the frequency spectrum. The use of a spectrum mask is important to limit signal spectral content.

2.4 OFDM Demodulation

On the receiving side, the signal will be converted from serial to parallel and then the cyclic prefix should be removed. Afterwards, an FFT will be applied to the signal before the estimating stage using the channel estimator. To demodulate the signal using either a QAM demodulator or PSK modulator, a parallel to serial converter is applied. These are the main demodulation stages minus several important steps such as filtering and symbol synchronization.

2.4.1 Serial to Parallel Conversion

Assume that the signal that is received is down-converted successfully and both of the OFDM transverse sides are synchronized in time. Then, the OFDM sequences will be converted to shorter OFDM symbols. Each received OFDM frame has the length of $X_{len} = M(T_{sub} + T_G)$, and these frames will be converted to M parallel streams preparing them to be demodulated.

2.4.2 Guard Period Removal

At this stage, the guard period that was inserted previously on the transmission side can be removed. With the assumption that we have perfect estimation for the receiver, we can then proceed to the guard removal stage. To get the OFDM symbols to their original form, the appended cyclic prefix should be removed from the received parallel baseband OFDM signals. It is a simple process where the cyclic prefix of length T_G is removed to get back the original length of the OFDM symbols T_{sub} as shown in Figure 2.9.

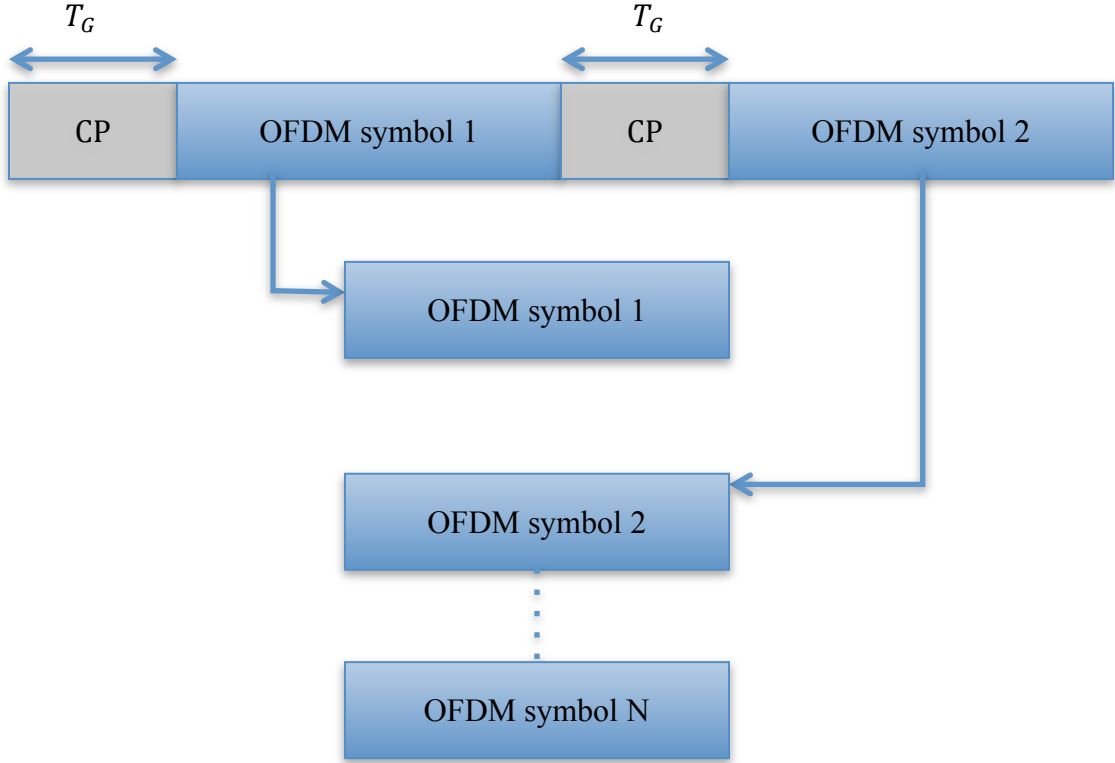

Figure 2.9: Guard Period Removal

2.4.3 Fast Fourier Transform (FFT)

After removing the guard intervals, an FFT procedure is used on the OFDM symbols to convert the real values to frequency domain. In this stage we extract the sub-carrier values to get the original information without the pilot symbols. The use of FFT makes it easier to recover the sub-carriers in one step without using a huge number of filters and oscillators. Assuming the signals are down-converted and there is perfect time synchronization, we can express the digital signal as follow:

$$r(k) = \exp\left(j \frac{2\pi kv}{N_{FFT}}\right) \sum_{p=0}^{k-1} h_p s(k - \eta) + n(k) \quad (2.6)$$

where η is the set of the path time delay and h_p is the complex gain. Also the AWGN is denoted by $n(k)$ and the carrier spacing offset is represented by ν . As mentioned previously, when the time synchronization is achieved perfectly and the cyclic prefix removed successfully, then we have a signal sequence formed from 0 to $N_{FFT}-1$ with maintained orthogonality.

2.4.4 Equalization and Channel Estimation

Even though the CP has a longer duration than the supreme delay of the multipath channel, there is still a slight chance of having ISI, the main reason being channel frequency selectivity.

2.4.4.1 Equalization

After applying FFT on the received OFDM signal, we can eliminate the distortion by using a channel equalizer. The coefficient of the equalizer is multiplied by the samples of the subcarrier independently to force diminished ISI. There are several criteria to calculate for a suitable equalizer coefficient. One criterion is Zero-Forcing (ZF). The following equation shows how the equalizer coefficient can be calculated:

$$C_n = \frac{1}{H_n} \quad (2.7)$$

Where the frequency response for any one of the sub-carriers is denoted by H_n . The drawback of this criterion is that when the channel frequency response is small in one sub-carrier, the noise at that sub-carrier will be increased, which results in an inverse relationship in the channel frequency response.

2.4.4.2 Channel Estimation

After equalizing the subcarriers individually, pilot symbols are needed to perform and implement the channel estimation [34]. These pilots are inserted on the transmitting side in between the sub-carriers. This process of inserting happens as mentioned previously, just before proceeding to the IFFT operation. Since the equalization of the OFDM channel is applied in the frequency domain, it is important to estimate the frequency response. In a more complicated scenario, tracking the channel is required to estimate the multipath channel that is time varying in nature [37].

2.4.5 Converting from Parallel to Serial

This converter is similar to the operation on the transmitter side where the parallel OFDM symbols were converted to serial sequences. The process is preparing the OFDM symbols for the next stage. As mentioned before, the parallel OFDM symbols, which have shorter duration, are converted to get the original duration length and prepared for demodulation. This is to try to recover the binary signal that is transmitted through this model.

2.4.6 Symbol Demodulation

The symbol demodulation stage is the last and final stage in the OFDM transceiver. This stage, which is also called de-mapping, recovers the input binary information that went through all these steps on both sides of the system. As stated previously, the binary information of the original input was mapped to complex-valued signals depending on the phase shift of these symbols and also their amplitude.

Depending on the type of transmitter modulation, the output of converting parallel symbols to serial symbols would have a specific number of complex-valued signals. To be more precise, if we modulated a binary input signal using QPSK we would have four complex-valued signals for each symbol on the constellation diagram. As a result, the received signal prior the modulation stage has four complex-valued signals. These values will not appear on the constellation diagram exactly as they were on the transmitter side. To round the error data to the closest correct data on the constellation diagram we can use a decision-metric algorithm.

If we have a perfect transmitter and receiver we would have identical input and output, which is nearly impossible. There are several reasons for not having a perfect modulation scheme, including residual equalization errors that cause mismatch among the transmitting side and receiving side in terms of phase shift and the value of the amplitude.

Chapter Three: PAPR Reduction Techniques

The use of IFFT operation in the OFDM transmitter side creates a time domain high peak value due to adding the subcarrier components. In this case of using multicarrier systems, we would have a high PAPR. In contrast, the SC system does not face these issues with the PAPR because its design does not contain an IFFT operation [40]. In this chapter we will go through the PAPR in detail including its definition and the mathematical concept behind it. Also, PAPR reduction techniques will be explained in general then more focused as we go through the technique that I used in this thesis including: clipping technique, clipping and filtering technique, and Partial Transmit Sequence (PTS) technique [9] [23].

3.1 PAPR

Calculating the PAPR depends on the ratio between the maximum power of the complex pass-band signal and its mean power [22]. The following equation shows how to calculate the PAPR.

$$PAPR = \frac{\max(x^2(t))}{\text{mean}(x^2(t))} \quad 3.1$$

Where the amplitude of the complex pass-band signal is denoted by $x(t)$

In the worst-case scenario, by adding all the subcarriers, the OFDM peak power for N subcarriers equals to N . In M-QAM and M-PSK, we have noticed that the PAPR increases when we have a higher modulation order. If the number of subcarriers increases to ∞ , the maximum PAPR for the signal x_k is represented as follows:

$$PAPR_m = \frac{N}{N/N} = N \quad 3.2$$

The rate of maximum PAPR is correlated to the subcarriers number, increasing and decreasing as the number increases or decreases. We have Gaussian distribution for the signal x_k when k goes from 1 to N and it can be represented as follow:

$$P(x_k < PAPR_m) < 1 \quad 3.3$$

The probability of the signal x_k having a smaller $PAPR$ than the one that is given $PAPR_m$ can be shown in the following equation:

$$\lim_{N \rightarrow \infty} \prod_{k=1}^N P(x_k < PAPR_m) = 0 \quad 3.4$$

On the other hand, we can represent the probability of having $PAPR$ of the same signal x_k greater than the probability of $PAPR_m$ for the same number of subcarrier N and the following equation shows that:

$$\lim_{N \rightarrow \infty} (1 - \prod_{k=1}^N P(x_k < PAPR_m)) = 1 \quad 3.5$$

To calculate the possibility of having PAPR greater than the threshold value for the OFDM signal, we could use the CCDF. By simulating the CCDF, we compare the theoretical values with the simulation results and the PAPR keeps increasing when the number of carriers increases. In the simulation a figure shows the CCDFs of OFDM signals with different numbers of subcarriers [24].

If we use linear amplifiers that have larger input than the nominal value, we could have an output with a nonlinear distortion. In Figure 3.1, a diagram for a High Power Amplifier (HPA) shows the input and output characteristic. In this diagram, the input power is denoted by P_{in} while the output power is represented by P_{out} .

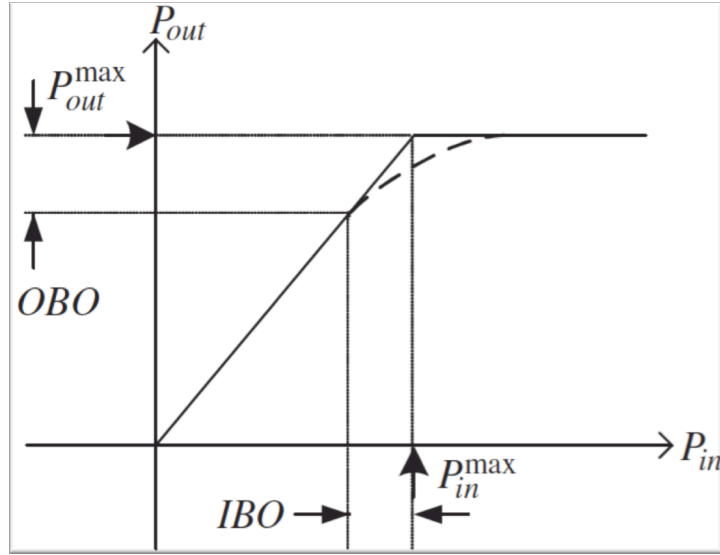

Figure 3.1: Input and output characteristic of an HPA [15].

To retain linearity, the maximum output power is limited by the maximum output power value P_{out}^{max} and the maximum input power is bounded by the maximum input power value P_{in}^{max} . Both the input and output power are backed off to ensure a linear operation and the area of the backing off is termed Input Back-Off (IBO) and Output Back-Off (OBO). The following two equations describe the IBO and the OBO in terms of the input-output power and its maximum values:

$$IBO = 10 \log_{10} \frac{P_{in}^{max}}{P_{in}} \quad 3.6$$

$$OBO = 10 \log_{10} \frac{P_{out}^{max}}{P_{out}} \quad 3.7$$

In the case of having nonlinear HPA characteristics, which is caused by having larger input than its nominal value, we could have out-of-band radiation that overlaps between the adjacent signals. Another problem that appears with the nonlinear characteristic of HPA is the in-band distortion which leads to serious issues including attenuation, spinning, and offset of the received signals.

3.2 PAPR Reduction Techniques

To reduce the effects of high PAPR in the OFDM systems, we could use several power reduction techniques. One of the simplest techniques is clipping, where the PAPR is reduced by clipping the peaks [41]. Coding is another power reduction technique where code words are selected to minimize the PAPR, but its drawback is that when the code rate is minimized the bandwidth efficiency will suffer [13] [14].

Another technique called the probabilistic technique involves transmitting one of the lowest PAPR OFDM symbols to reduce the PAPR occurrence probability [43]. But this technique contains some disadvantages, including increased complexity when using higher numbers of subcarriers. The adaptive pre-distortion technique is another type, which can be used to eliminate nonlinear effect, which appears when using HPA. We can apply another technique called DFT-spreading to decrease the OFDM PAPR to the single-carrier transmission levels. Using it with the uplink transmission, as a mobile terminal, is helpful in reducing power consumption. The following sections analyze some of the PAPR reduction techniques in details. The research concentrates on three techniques including the clipping technique, the clipping and filtering technique, and PTS technique.

3.2.1 Clipping Technique

Clipping is the one of the simplest techniques that can be used to reduce power by picking a maximum level for the transmitted signal [5] [12]. However, this technique has several drawbacks:

- In-band distortion.
- Out-of-band radiation.

There is a way to eliminate the effects of the out-of-band radiation by filtering the signal but the signal may exceed the maximum level of the clipping operation . Figure 3.2 shows the block diagram of clipping and filtering technique that can be used to reduce PAPR, where the number of subcarriers is denoted by N and the oversampling factor is represented by L .

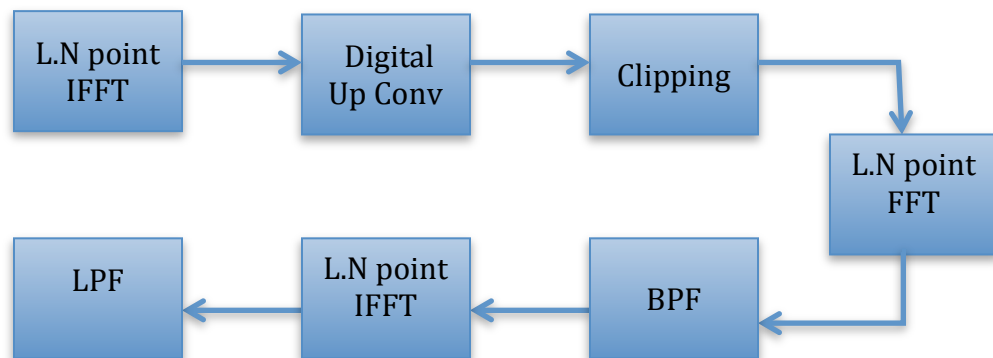

Figure 3.2: The Scheme of Clipping and Filtering Technique for PAPR

The modulated pass-band signal is represented by $x^p[m]$ with carrier frequency f_c . We denote the pass-band-modulated clipped signal by $x_c^p[m]$. The following equations express the clipping level of this reduction technique:

$$x_c^p[m] = \begin{cases} -A & x^p[m] \leq -A \\ x^p[m] & |x^p[m]| < A \\ A & x^p[m] \geq A \end{cases} \quad 3.8$$

or

$$x_c^p[m] = \begin{cases} x^p[m] & \text{if } |x^p[m]| < A \\ \frac{x^p[m]}{x^p[m]} * A & \text{otherwise} \end{cases} \quad 3.9$$

where the clipping level is represented by A and (CR) is the clipping ratio that can be characterized as follows:

$$CR = \frac{A}{\sigma} \quad 3.10$$

We have in equation 3.10 the RMS value of OFDM signal is denoted by σ and it is known that $\sigma = \sqrt{N}$ is for the baseband and $\sigma = \sqrt{N/2}$ is for the passband OFDM signal.

3.2.2 Clipping and Filtering

The disadvantages of using the clipping technique include signal distortion and radiation. The performance of the BER will be seriously affected as a result of using the clipping approach. To overcome these issues, filtering is applied to reduce the effect of the out-of-band interference and to improve the BER performance [35].

As shown in figure 3.2, the FFT-IFFT filter is applied to make the signal pass through a band-pass filter (BPF) and after that through a low-pass filter (LPF). The output of the filtering stage is a less degraded BER performance and reduced out-of-band radiation. However, after applying the filtering, the PAPR reduction improvements are gained at the cost of the peak regrowth, where the signal could exceed the clipping level.

3.2.3 Partial Transmit Sequence (PTS) Technique

With the PTS technique, we could face more complexity than with other techniques in terms of pointing the phase vector optimum [24]. To overcome that issue, a useful algorithm is offered to reduce the commutation number, which becomes much lower than with the last PTS technique. The PTS technique splits the data block of X symbols to a number of sub-blocks with Z disjoint as 3.10 shows:

$$X = [X^0, X^1, X^2, \dots, X^{Z-1}]^T \quad 3.11$$

Where, in our case, X^i represents the subcarriers that have the same size and are located in sequence form. In the selective mapping technique, it is easier because there is scrambling for all subcarriers, while in the PTS technique, there is scrambling for every sub-block. By multiplying every sub-block with phase factor $b^z = e^{j\theta^z} = 1, 2, 3, \dots, Z$, the value IFFT can be represented as follows:

$$x = IFFT\{\sum_{z=1}^Z b^z X^z\} = \sum_{z=1}^Z b^z IFFT\{X^z\} = \sum_{z=1}^Z b^z x^z \quad 3.12$$

Where x^z is related to the partial transmit sequence. To reduce the PAPR, a selection of the phase vector can be represented as follows:

$$[\tilde{b}^1, \dots, \tilde{b}^z] = \arg \min_{[\tilde{b}^1, \dots, \tilde{b}^z]} \left(\max_{n=0,1,\dots,N-1} \left| \sum_{z=1}^z b^z x^z [n] \right| \right) \quad 3.13$$

For the lowest PAPR vector, the signal for the time domain is shown as follow:

$$\tilde{x} = \sum_{z=1}^z \tilde{b}^z x^z \quad 3.14$$

The performance of the PAPR improves as long as the number of the sub-blocks continues to increase [44].

Chapter Four: Simulation Results

The comparison between the SC and MC schemes in terms of bit error rate (BER) performance is represented by different modulation techniques, starting with varying the order of the modulation technique M-PSK ($M = 2, 4, 8, 16$). For SC and MC schemes, the input signals were chosen to be random signals that propagated through the same channel (AWGN). The results show that the multi-carrier (OFDM) technique outperforms the single-carrier in terms of BER. However, there is a trade-off relationship where the PAPR gets higher when using OFDM. Calculating the PAPR depends on the ratio between the maximum power of the complex pass-band signal and its mean power [16].

To overcome this kind of drawback we could apply PAPR reduction techniques where the performance of the PAPR is improved (reduced) but the BER performance would be affected. The clipping is applied first to see the changes on the output and after which the clipped signal is filtered to compare the results after that process. The BER performance is investigated in this comparison using MATLAB code.

Before going through the simulation results we have to give brief definitions for the technical terms that are used in this simulation. The bit error rate (BER) can be explained as the total of affected bits divided by the total transmitted bits for a specific time interval. For this calculation we get a percentage quantity that is unit-less. To calculate the possibility of having PAPR greater than the threshold value for the OFDM signals and the single-carrier signals, we could use the (CCDF).

4.1 M-PSK Comparison for SC and OFDM

MATLAB code was used to carry out the simulation for this thesis. The BER performance is clearly affected by changing the value of M in M-PSK; the lower the order, the better the performance as shown in Figure 4.1. The BER curves of single-carrier are represented in different colors where the values of M-PSK has $M= 2, 4, 8,$ and 16 . The curves illustrate that the best BER performance occurs when BPSK is applied. In Figure 4.2, we can notice the same thing when the OFDM scheme is used and how the BER performance is affected badly when the order of M-PSK increases. The 16-PSK-modulation technique has the worst BER performance compared to the lower M-PSK order.

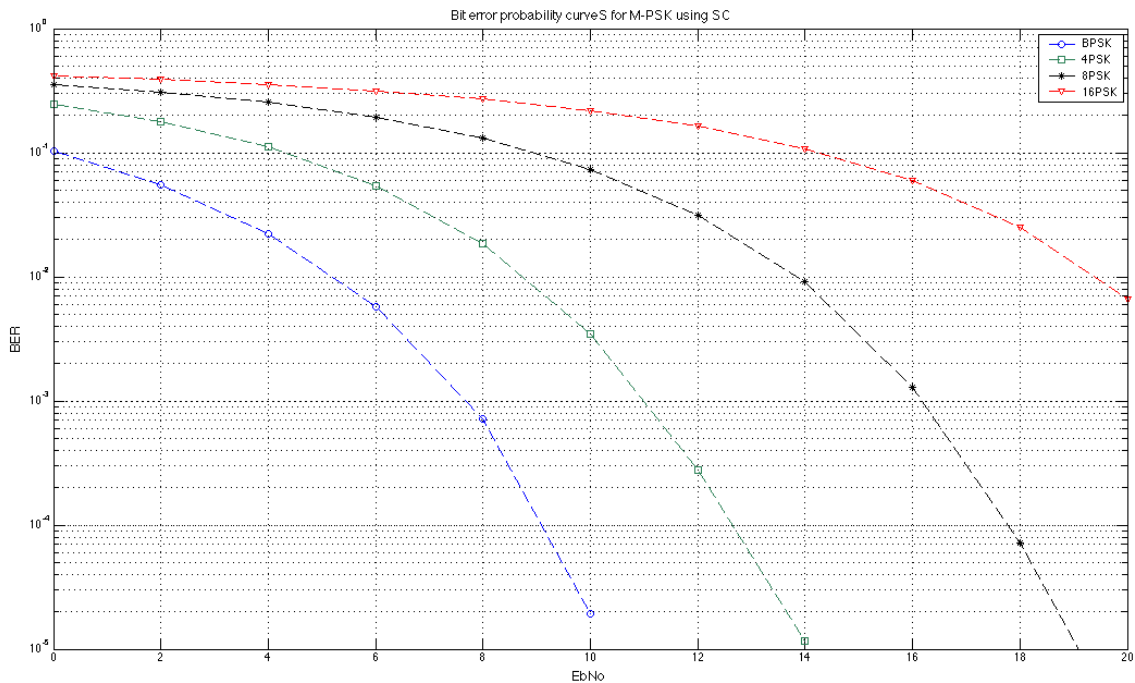

Figure 4.1: BER Curves for SC using M-PSK

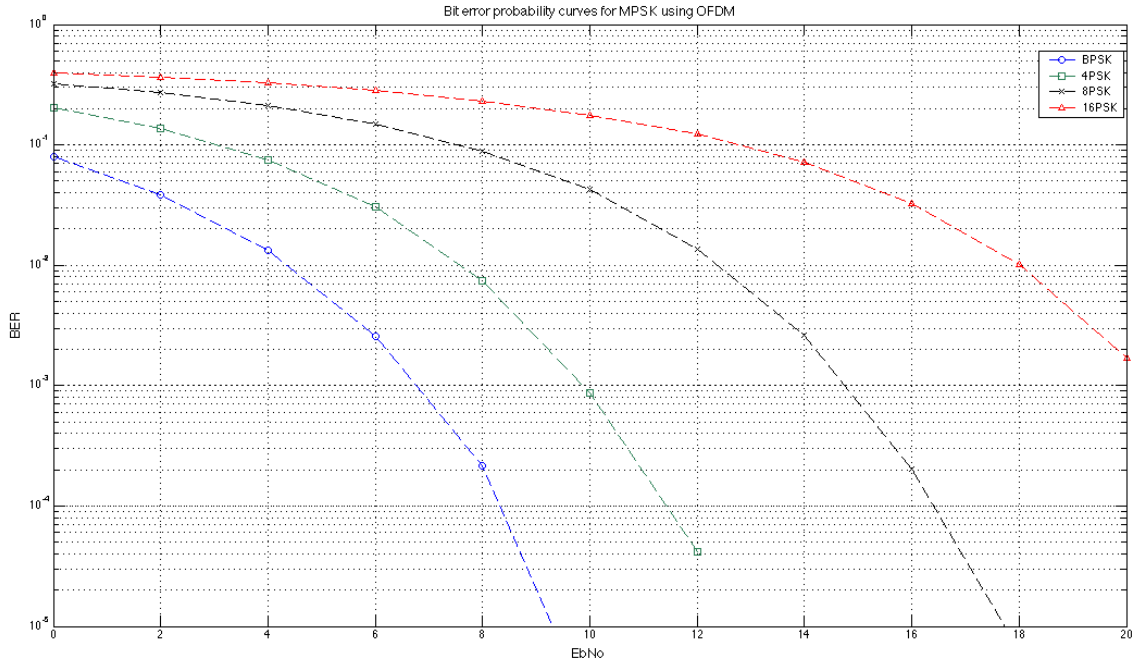

Figure 4.2: BER Curves for OFDM using M-PSK

The other comparison concerns the CCDF measurements for both single and multi-carriers. The curves that are shown in Figure 4.3 represent the CCDF measurements for SC and, as we can see in the figure, the value of PAPR is not affected by changing the M-PSK order. Despite the BER performance for SC, the low PAPR ratio provides us with a performance that does not consume much power. On the other hand, Figure 4.4 shows that the CCDF measurements are disturbed by the use of OFDM. From the figure we can see that the PAPR values are escalated from around of 2.5 dB in SC to more than 12 dB in OFDM. This is the main drawback of using the OFDM transmission scheme. Moreover, the PAPR value increases when the value of M gets higher.

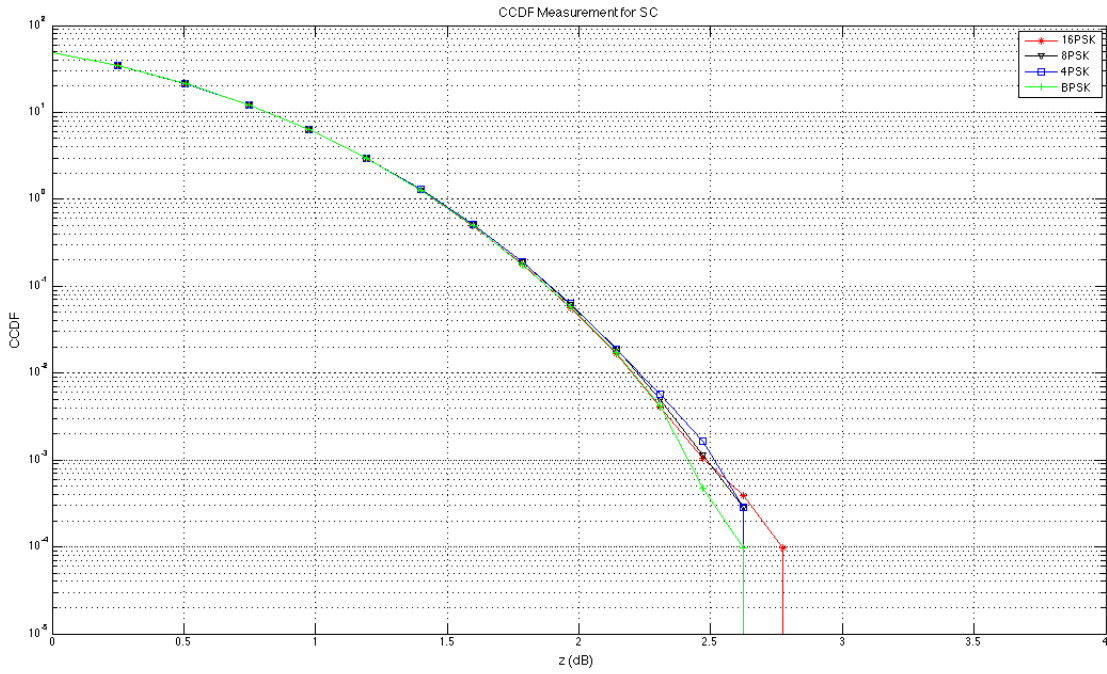

Figure 4.3: CCDF Measurements for Single-Carrier using M-PSK

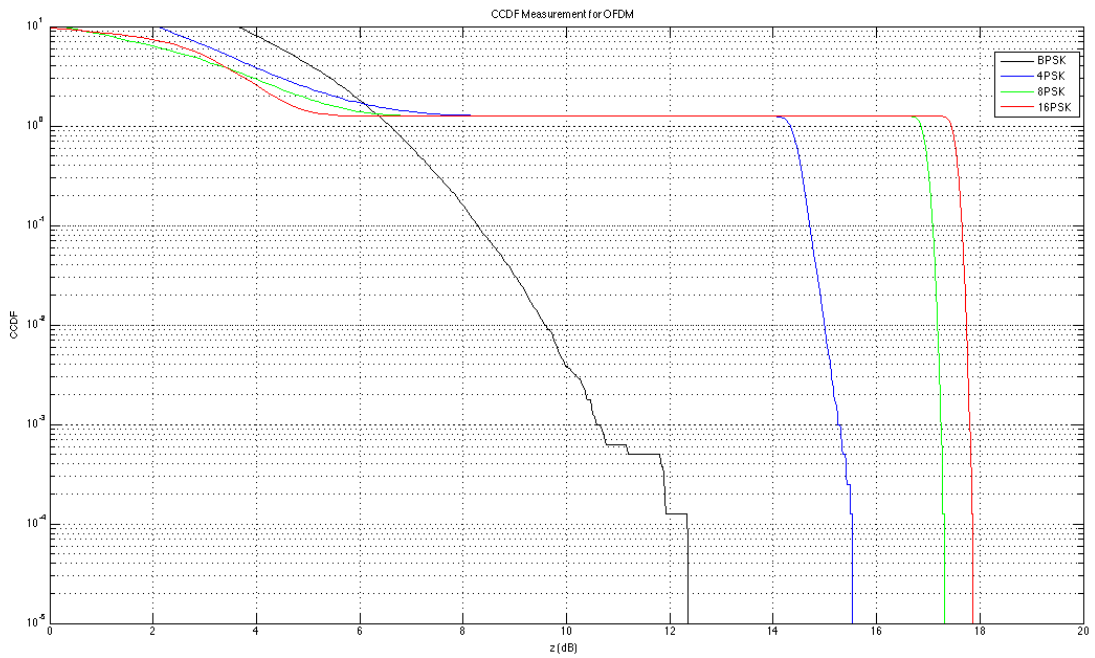

Figure 4.4: CCDF Measurements for Multi-Carrier using M-PSK

4.2 Comparison Between OFDM and SC

A comparison has been stated between OFDM and SC in terms of BER performance with respect to SNR as Figure 4.5 shows. The analysis went through different modulation methods and it began with the simplest modulation method BPSK. From the curves the improvement of the BER performance can be seen when using OFDM compared to the BER value using SC. Even with that indication of lower BER performance, the OFDM still has its own drawback that appears in Figure 4.6. The red curve represents the PAPR distribution for OFDM, which is much higher than the blue curve that represents the SC. The PAPR ratio increased from 2.8 dB in SC to 12.5 dB in OFDM and to overcome this problem power reduction technique should be used.

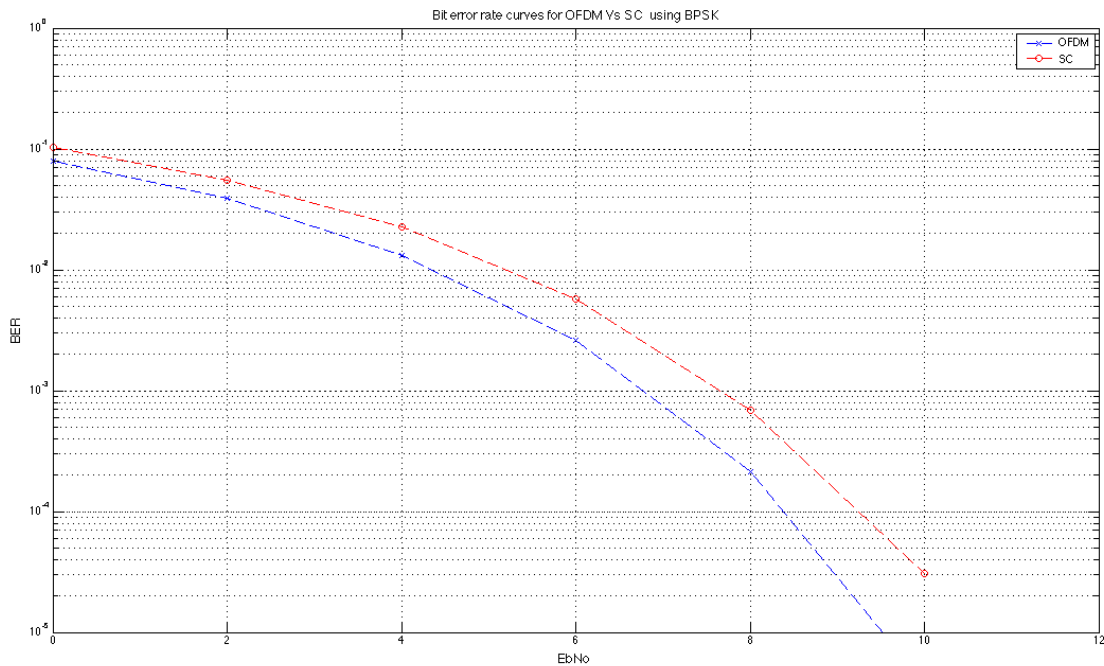

Figure 4.5: BER Curves for OFDM Vs. SC using BPSK

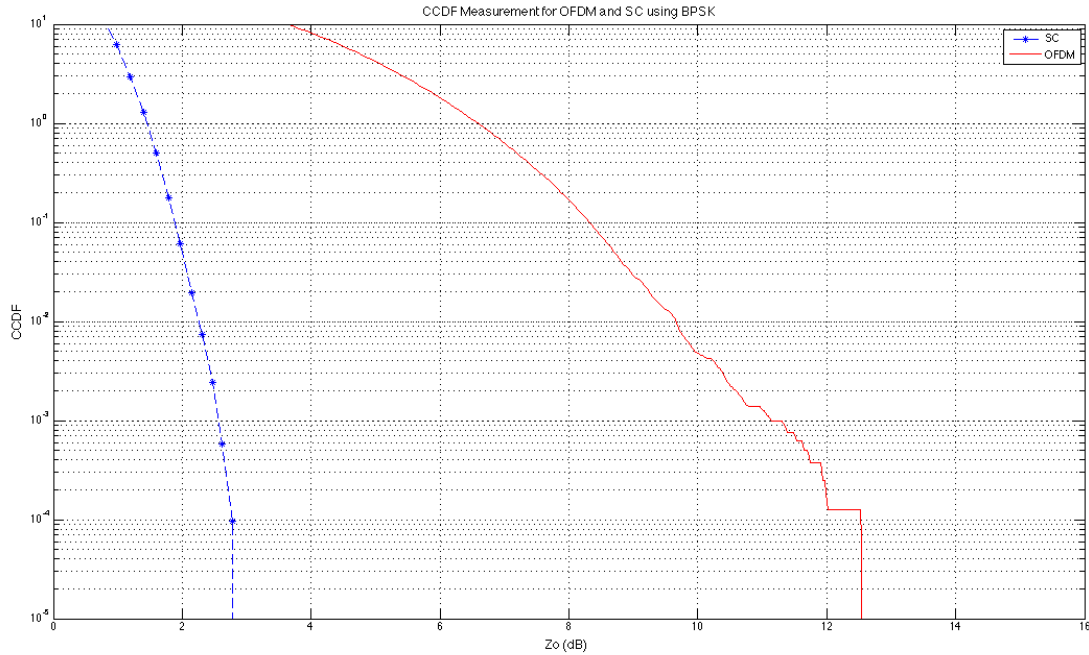

Figure 4.6: CCDFs of OFDM Vs. SC using BPSK

In Figure 4.7, two curves represent a comparison between the OFDM and the SC transmission systems. The comparison shows the BER performance with respect to SNR values when using 4QAM. The blue curve represents the OFDM performance and the red curve represents the SC. From the curves, it can be seen that the OFDM transmission system improves the BER percentage as compared to the SC. As stated before, the use of the OFDM transmission has a major drawback, which is made evident in the PAPR distribution as shown in Figure 4.8. The PAPR ratio jumped from 2.3 dB in SC to 15.6 dB in OFDM.

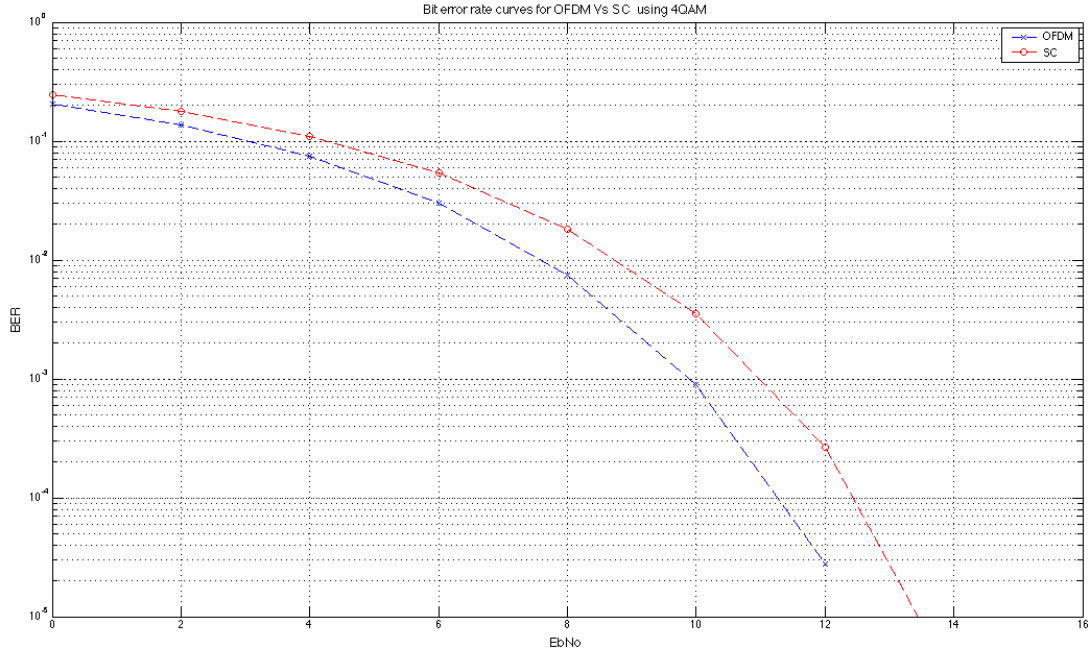

Figure 4.7: BER Curves for OFDM Vs. SC using 4QAM

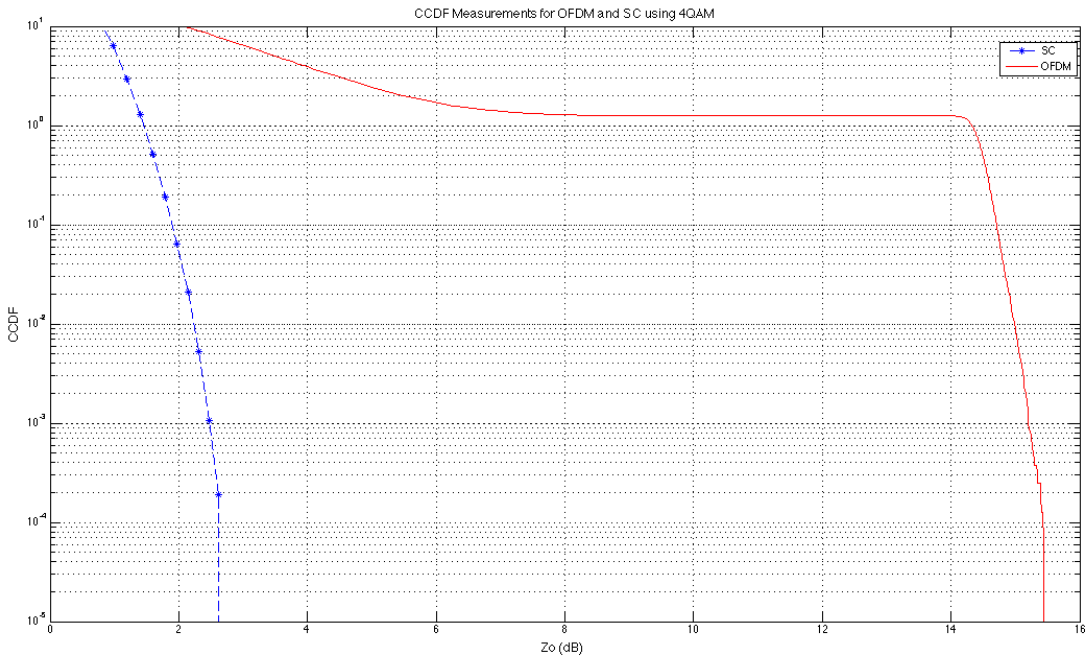

Figure 4.8: CCDFs of OFDM Vs. SC using 4QAM

The two curves in Figure 4.9 show the BER percentage after applying the 8PSK modulation scheme. As stated before, the BER performance of the OFDM is improved and outperforms the SC scheme performance when using BPSK and 4QAM modulation techniques. Still, there is a drawback with using OFDM, which is the increase of PAPR ratio. The PAPR ratio with OFDM increased to 17.2 dB compared to 2.3 dB in the SC scheme. This issue can be dealt with by applying power reduction techniques, as is stated in the following section.

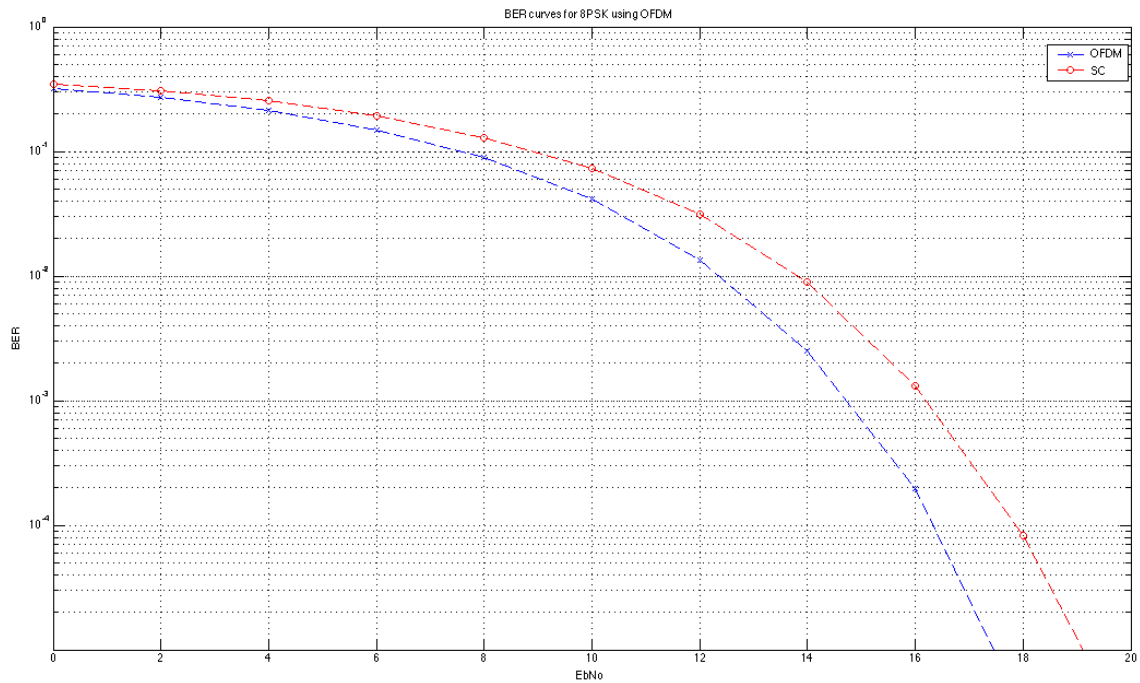

Figure 4.9: BER Curves for OFDM Vs. SC using 8PSK

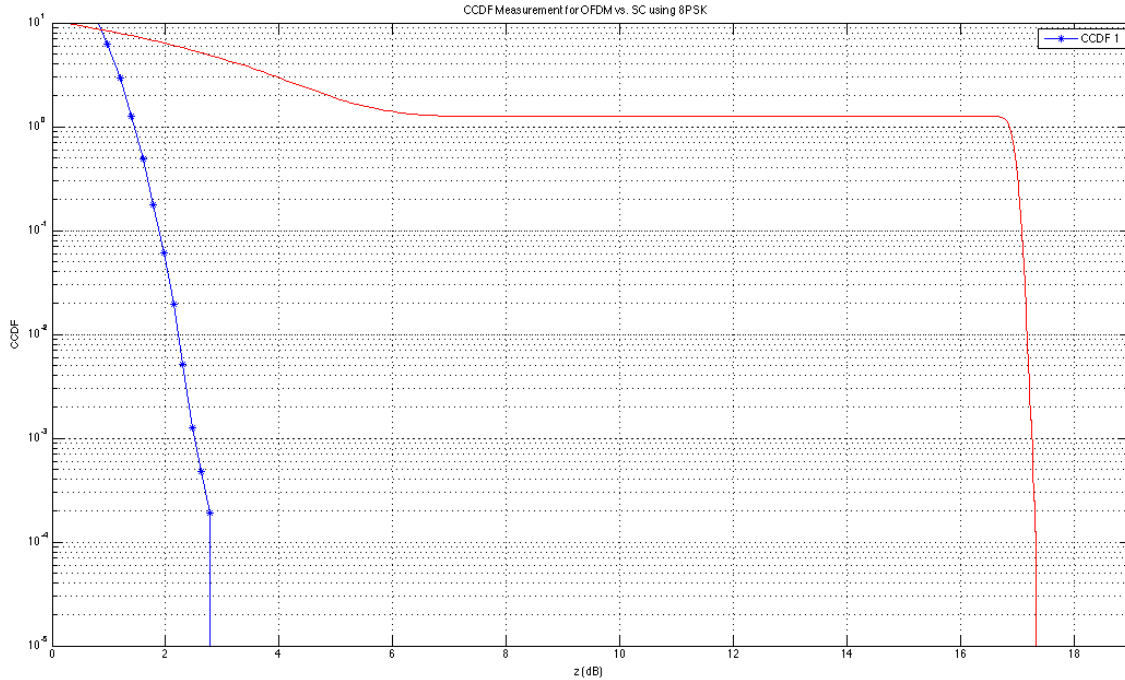

Figure 4.10: CCDFs of OFDM Vs. SC using 8PSK

4.3 PAPR Reduction Using Clipping and Filtering

The technique of clipping is the easiest way to reduce power by setting a maximum level for the transmitted signal. However, this technique has several disadvantages such as distortion radiation. The performance of the BER is seriously affected when using the clipping approach, but it can be improved by filtering to decrease the effect of the out-of-band interference and to improve the BER performance.

Bandwidth	1 MHz
Clipping Ratio (CR)	0.8, 1.0, 1.2
Order of Modulation	QPSK
Interval (CP)	32

Table 4.1: Parameters used for Simulation

Based on [15], a QPSK/OFDM system was simulated as well as the algorithm of clipping and clipping and filtering of the OFDM symbol. The parameters in table 4.1 have been used for the purpose of analyzing the clipping and filtering technique. The behavior of this method is evaluated in the following three aspects.

- The power spectral density where ripples of the in-band and radiation of the out-of-band are detected
- PAPR or the crest factor distribution
- BER performance

The following figures represent the power spectrum of a pass-band OFDM signal using a random input signal. The input signal and the cyclic prefix insertion are shown as well as the clipped version of the pass-band signal and the filtered signals. The results show that the OFDM signal follows a pattern that is similar to the Gaussian distribution. Figure 4.11 shows the input baseband signal after duplicating the symbol end and inserting it at the front. To ensure a minimum effect of ISI we should set the length of the CP longer or at least at the same length as the greatest multipath channel delay. Figure 4.12 shows the pass-band signal before applying the clipping and filtering process. This power spectrum needs to be clipped to reduce the peak ratio.

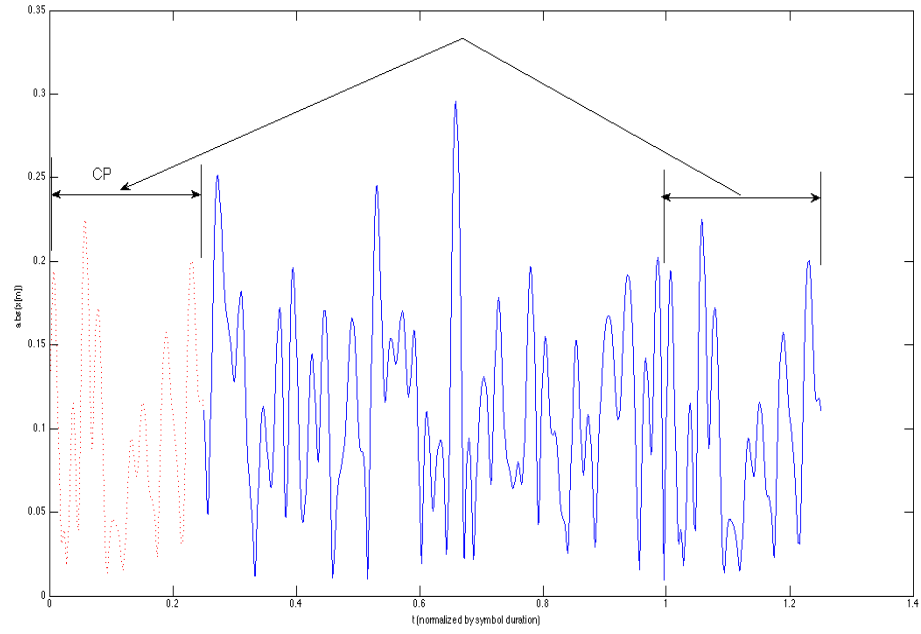

Fig 4.11: Baseband signal after adding the cyclic prefix.

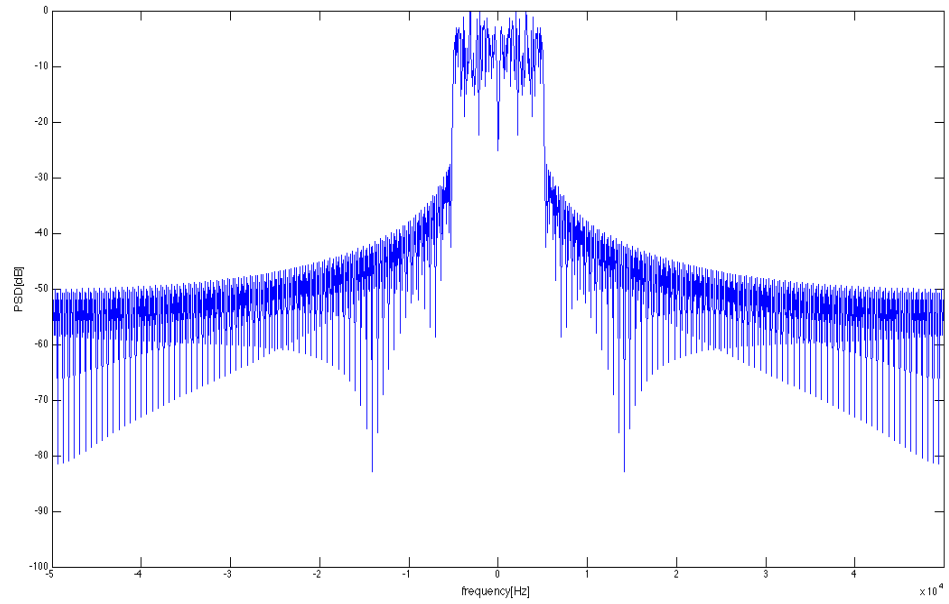

Fig 4.12: The power spectrum of the pass-band signal.

It is evident from Figure 4.13 that the clipped version of the OFDM signal is distributed within the clipping level, whereas Figure 4.14 shows that the peak value is beyond the clipping level for the filtered signal. The disadvantage of the clipping process is that the out-of-band spectrum is increased after clipping, but it can be reduced again after filtering the signal as in Figure 4.14, though there is a small peak regrowth in the PAPR after going through the filtering process.

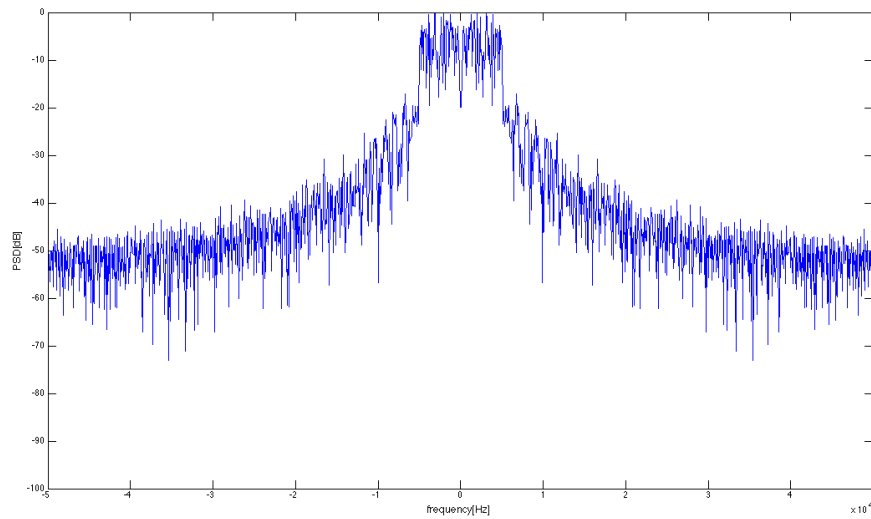

Fig 4.13: The power spectrum of the clipped signal.

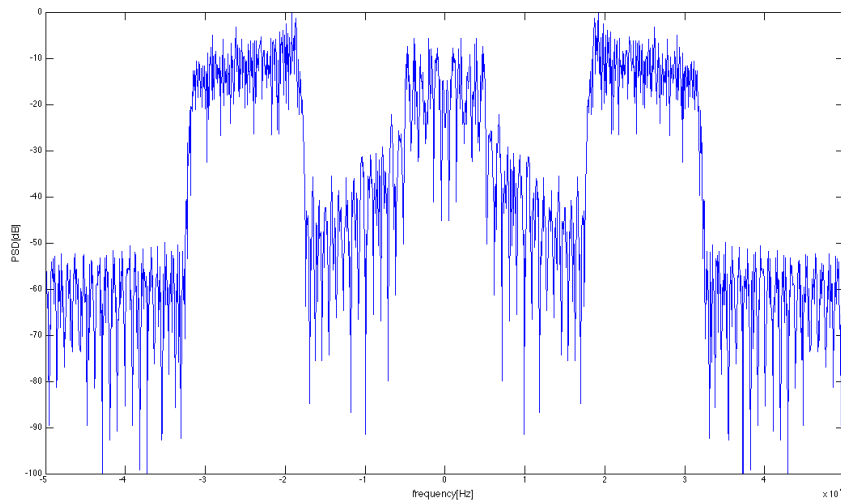

Figure 4.14: The power spectrum of the clipped and filtered signal.

To see the effects of applying clipping and filtering techniques, we studied the BER performance and the PAPR distribution for the OFDM signal. The CCDF of the Crest Factor (CF) represents the PAPR distribution, where the CF is square root of PAPR. The simulation was run for three different values of the clipping ratio. After clipping, there is clear drop in the PAPR distribution and the highest PAPR reduction effects occur at the lowest clipping ratio. At CCDF of 10^{-1} dB, the unclipped signal has PAPR value of 14.3 dB and it dropped to 5.2 dB when CR equals to 1. As a result of the radiation, the BER performance of the clipped signal worsened and it improved slightly when the CR rose.

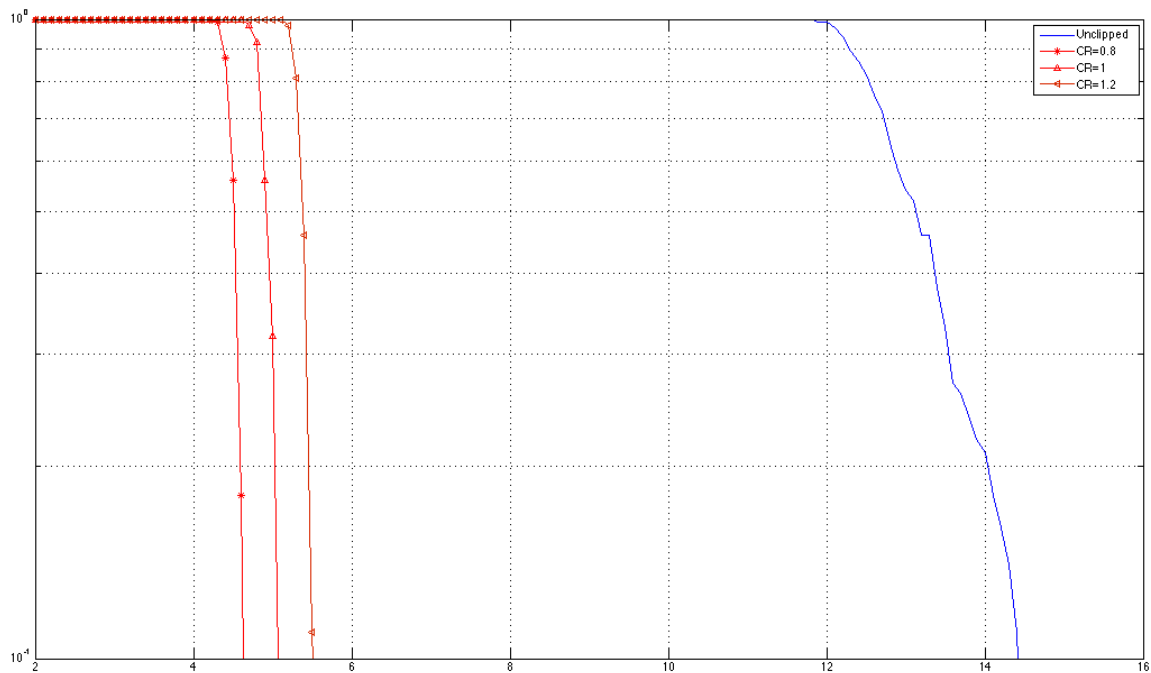

Figure 4.15: PAPR distribution for clipped and unclipped signals.

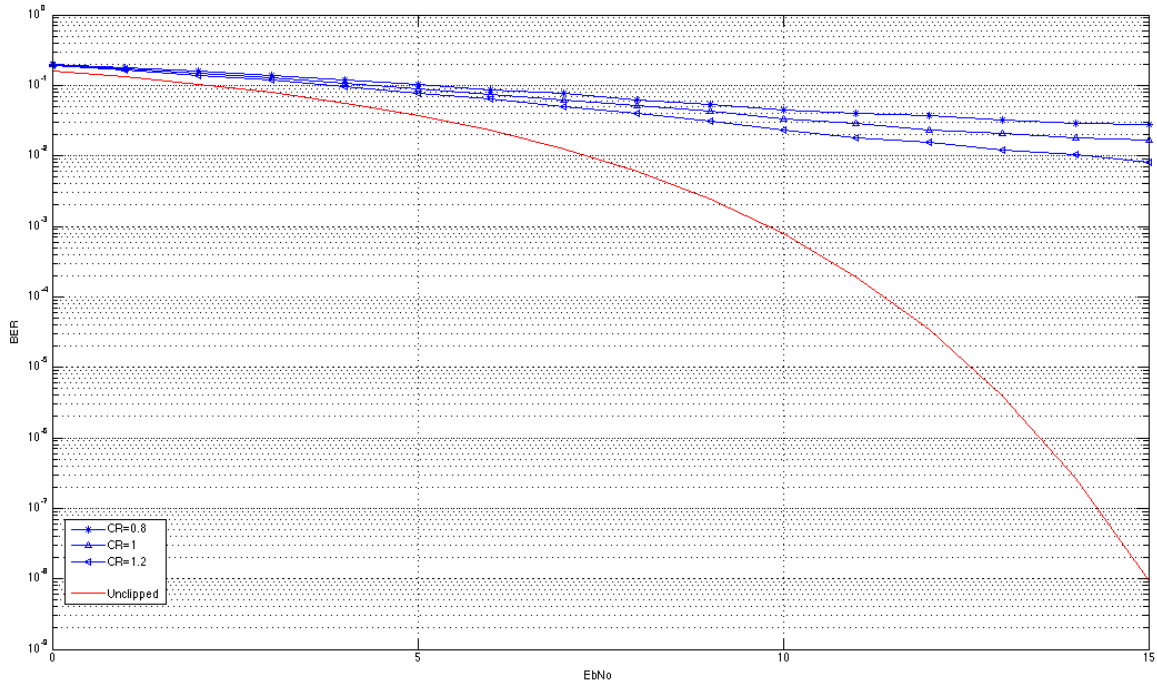

Figure 4.16: BER versus SNR for clipped and unclipped signals.

To overcome the problem of out-of-band radiation the clipped signal was filtered. The BER performance versus SNR improved as shown 4.18. After applying the clipping and filtering process at $CR = 1.2$, the BER was reduced to 0.001 at 10 dB SNR compared to 0.021 for the clipped signal. Due to the trade off relationship between the PAPR distribution and the BER performance, the PAPR was badly affected. The PAPR distribution for the clipped signal was 5.2 dB when $CR = 1$ and it increased to 9 dB after the filtering stage.

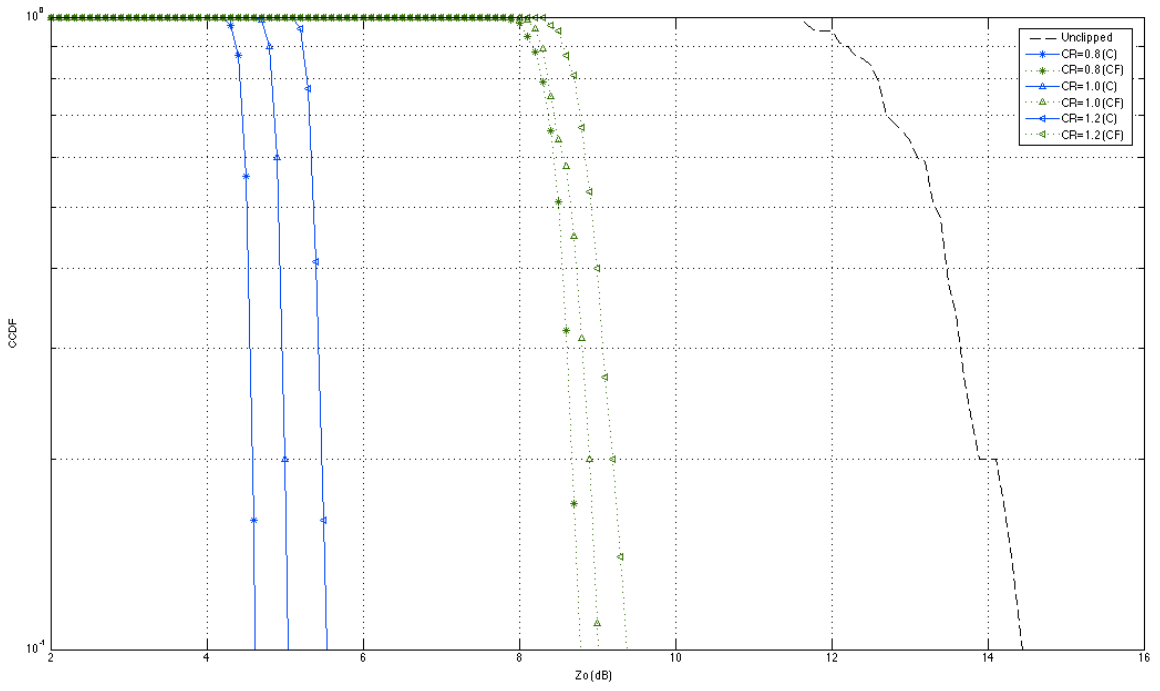

Figure 4.17: PAPR distribution for clipped, filtered, and unclipped signals.

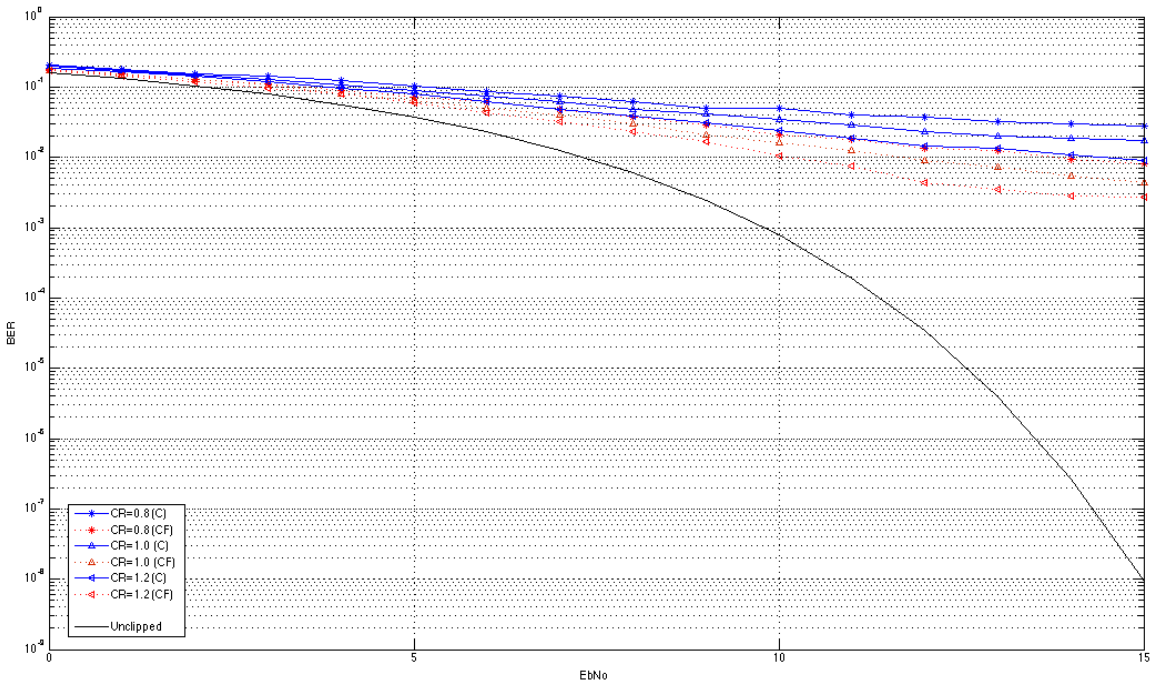

Figure 4.18: BER versus SNR for clipped, filtered, and unclipped signals.

4.4 Results Evaluation

For the first part of the results, a comparison was proposed between the OFDM and the SC in terms of BER performance. The results show that the OFDM outperformed the SC and the BER was clearly reduced. Also, the results show that the higher the M-PSK orders the worse the BER performance. The PAPR distribution was constant for the SC after varying the M-PSK order while the PAPR increased dramatically for the OFDM. The following table illustrates the results that we maintain in the comparison section between OFDM and SC in terms of BER and PAPR:

Modulation	BER for SC	BER for OFDM	PAPR for SC	PAPR for OFDM
BPSK	0.0060	0.0012	2.8 dB	12.5 dB
4QAM	0.010	0.0065	2.8 dB	15.6 dB
8PSK	0.130	0.090	2.8 dB	17.2 dB

Table 4.2: Comparison between OFDM and SC.

Since the OFDM is performing better than the SC, we attempted to address the high PAPR issue. The clipping and filtering technique was used to reduce the PAPR distribution. After clipping, the PAPR values dropped dramatically but with a tradeoff of higher out-of-band radiation. After applying the filtering process, the BER dropped from 0.021 to .001 at 10 dB SNR. The following table represents a comparison between the output results of the last simulation section:

QPSK (CR=1)	BER	PAPR
Uncropped	0.001	14.3 dB
Clipped	0.022	5.2 dB
Clipped and Filtered	0.01	9.0 dB

Table 4.3: Comparison between clipped, filtered, and unclipped signals.

Chapter Five: Conclusion and Future Work

5.1 Conclusion

BER performance for the OFDM and SC transmission schemes was studied and analyzed. In both cases, the transmitted data had the exact same parameters and the signals were propagated through the same channel (AWGN). The results reveal advantages and drawbacks for both techniques. It was noticed that BER performance improved after using the OFDM compared to the SC scheme. On the other hand, high PAPR values were a major drawback of OFDM. This problem can be reduced using the PAPR reduction technique, which is the clipping and filtering technique.

The effect of using clipping and filtering technique on the OFDM signals was studied and it was concluded from the results that the PAPR could be decreased at lower CR for both clipped and filtered signals. For the clipped signal, the PAPR was reduced by more than 50% compared with the unclipped signal. However, the BER was affected badly and increased due to the radiation. A filter was used to decrease the distortion and radiation that resulted from clipping and to improve the BER performance. Despite the slight increase of the PAPR, the BER performance was improved.

5.2 Future Work

As for future work, I am thinking of combining two different PAPR reduction techniques to reap the benefits of both. I will try to apply PTS technique for a clipped signal to see whether the performance will improve or not. The idea as shown in Figure 5.1 concerns letting the signal go through the clipping process where the modulated pass-band signal is represented by $x^p[m]$ with carrier frequency f_c . The pass-band modulated clipped signal is denoted by $x_c^p[m]$. The following equations express the clipping level of this reduction technique:

$$x_c^p[m] = \begin{cases} -A & x^p[m] \leq -A \\ x^p[m] & |x^p[m]| < A \\ A & x^p[m] \geq A \end{cases} \quad 5.1$$

Where the clipping level is represented by A and (CR) is the clipping ratio that can be characterized as follows:

$$CR = \frac{A}{\sigma} \quad 5.2$$

Then proceeding through the PTC algorithms, I would try to improve the performance of our scheme. The PTS technique could present increased complexity than other techniques in terms of pointing the phase vector optimum [26]. To overcome this issue, a useful algorithm is offered to reduce the commutation number, which becomes much lower than with the last PTS technique [33]. The technique, where the PTS is used, splits the data block of X symbols to the number of sub-blocks with Z disjoint as 3.10 shows:

$$X = [X^0, X^1, X^2, \dots, X^{Z-1}]^T \quad 5.3$$

Where, in our case, X^i represents the subcarriers that have the same size and are located in sequence form. The selective mapping technique used is simpler in that there is scrambling for all subcarriers, while in the PTS technique there is scrambling for every sub-block. By multiplying every sub-block with phase factor $b^z = e^{j\theta^z}$, $z=1, 2, 3, \dots, Z$, the value IFFT can be represented as follows:

$$x = IFFT\{\sum_{z=1}^Z b^z X^z\} = \sum_{z=1}^Z b^z IFFT\{X^z\} = \sum_{z=1}^Z b^z x^z \quad 5.4$$

Where x^z is related to the partial transmit sequence. To reduce the PAPR, a selection of the phase vector can be represented as follows:

$$[\tilde{b}^1, \dots, \tilde{b}^z] = \arg \min_{[\tilde{b}^1, \dots, \tilde{b}^z]} (\max_{n=0,1,\dots,N-1} |\sum_{z=1}^Z b^z x^z [n]|) \quad 5.5$$

As shown in Figure 5.1, the scheme is constructed to take advantage of both techniques and to improve the performance of the BER by maintaining the orthogonally with the lowest possible PAPR ratio.

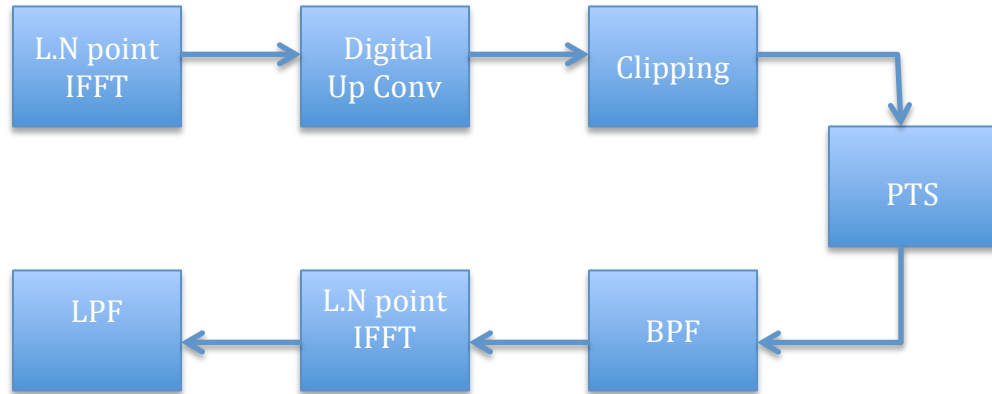

Figure 5.1: Block diagram for Clipped-PTS technique.

Reference

- [1] Geoffrey, Y., & Gordon, L. (2006). "Orthogonal Frequency Division Multiplexing for Wireless Communications". Springer.
- [2] Sizon, H. (2003). "Radio Wave Propagation for Telecommunication Applications". Springer.
- [3] RF Signal Propagation. (2011). Retrieved from <http://www.cs.nccu.edu.tw.htm>
- [4] Richard, N., & Ramjee, P. (2000), "OFDM for Wireless Multimedia Communications". Artech House.
- [5] Khaled, F., & Stefan, K. (2003). "Multi-Carrier and Spread Spectrum Systems". Wiley.
- [6] Wu, Y., & Zou, Y. (1999). "Orthogonal frequency division multiplexing: a multi-carrier modulation scheme". Consumer Electronics, IEEE Transactions on 41(3) pp: 392-399.
- [7] Mosier, R. & Clabaugh, R. (Jan.1965). "Kineplex: A Bandwidth-Efficient Binary Transmission System", AIEE Trans. Vol 76, Jan. 1958, pp. 723-28.
- [8] Cooley, J. W. and Tukey, J. W. (1965). "An algorithm for the machine calculation of complex Fourier series", Mathematics of Computation, 19, 90, pp. 297-301.
- [9] Jean, A. (2001). "New OFDM Peak-to-average Reduction Scheme". In IEEE Vehicular Technology Conference, Rhodes, Greece.
- [10] Princ, H. (May.1990). "Multicarrier Modulation for Data Transmission: An Idea Whose Time Has Come". IEEE Communications Magazine.
- [11] Karam, G., & Jeanclaude, I. (Feb.1995). "Transmission Techniques for Digital Terrestrial TV Broadcasting". IEEE Communications Magazine.
- [12] Albdran, S., Alshammari, A., & Matin, M. (2012). "Clipping and Filtering Technique for reducing PAPR In OFDM". *IOSR Journal of Engineering*, 2(9), 91-97.
- [13] Han, S., & Lee, J. (Apr.2005). "An overview of peak-to-average power ratio reduction techniques for multicarrier transmission". IEEE Wireless Communications, vol. 12, issue 2, pp. 56- 65.

- [14] Tao, J., & Yiyang, W. (Jun.2008). “An Overview: Peak-to-Average Power Ratio Reduction Techniques for OFDM Signals”. *IEEE Trans. Broadcasting*, Vol. 54, No. 2, pp. 257-268.
- [15] Cho, Y., Kim, J., Yang, W., & Kang, C. (2010). “MIMO-OFDM wireless communication with MATLAB”. Singapore: Wiley.
- [16] Albdran, S., Alshammari, A., & Matin, M. (2012). “The Sensitivity of Bit Error Rate (BER) Performance in Multi-Carrier (OFDM) and Single-Carrier”, *SPIE optics and photonics*.
- [17] Donald, N. (2004). “Air Interface for Fixed Broadband Wireless Access Systems”, *IEEE Standard 802*.
- [18] Tubbax, J. et. al, (2004). “OFDM versus Single Carrier: A Realistic Multi- Antenna Comparison”, *EURASIP Journal on Applied Signal Processing 2004:9*, 1275–1287_c.
- [19] Alshammari, A., Alabdran, S., & Matin, M. (September 2012). “Effects of Fading Channels on OFDM”. *IOSR Journal of Engineering*, 2(9), 116-121.
- [20] Bahai, A., Saltzberg, B., & Ergen, M. (2004). “Multi carrier digital communications: Theory and applications of OFDM”, Springer Science, New York.
- [21] Saleh, A.M. and Valenzuela, R.A. (1987). “A statistical model for indoor multipath propagation”. *IEEE J. Select. Areas Commun.*, 5(2), 128–137.
- [22] Ochiai, H., & Imai, H. (Feb. 2001). “On the Distribution of the Peak to Average Power Ratio in OFDM Signals”, *IEEE Trans. Commun.*, vol. 49, no. 2, pp. 280-289.
- [23] Han, S., & Lee, J. “An overview of peak-to-average power ratio reduction techniques for multicarrier transmission,” *IEEE Wireless Communications*, vol. 12,
- [24] Alhasson, B., & Matin M. (2011). “Reduction of PAPR for OFDM Downlink and IFDMA Uplink Wireless Transmissions”, *International Journal of Computer Science and Information Security*, Vol. 9, No. 3, pp 6-13, ISSN: 1947-5500.
- [25] Zhou, C., & Wunder, G., Bakker, H., & Kaminski, S. (2005). “OFDM-HSDPA: conceptual approach, simulation methodology and throughput performance,” in *Proceedings of the 10th International OFDM Workshop, Hamburg, Germany*.

- [26] Alhasson, B., & Matin, M. (2010). "The challenge of scheduling user transmissions on the downlink of a long-term evolution (LTE) cellular communication system". *Optics and Photonics for Information Processing IV, Proc. of SPIE Vol. 7797*, 779719.
- [27] Capoglu, I.R., Li, Y., & Swami, A. (2005). "Effect of Doppler spread in OFDM based UWB systems. *IEEE Trans. Wireless Commun.*, 4(5), 2559–2567.
- [28] Akki, A.S. & Haber, F. (1986). "A statistical model of mobile-to-mobile land communication channel". *IEEE Trans. Veh. Technol.*, 35(1), 2–7.
- [29] Smith, J.I. (1975). "A computer generated multipath fading simulation for mobile radio". *IEEE Trans. Tech.*, 24(3), 39–40.
- [30] Seidel, S.Y. et al. (1991). "Path loss, scattering and multipath delay statistics in four European cities for digital cellular and microcellular radiotelephone". *IEEE Trans. Veh. Technol.*, 40(4), 721–730.
- [31] Alard, M., & Lassalle, R. (1987). "Principles of modulation and channel coding for digital broadcasting for mobile receivers". *EBU Tech. Review* (224), 47–69.
- [32] Sari, H., Karam, G., and Jeanclaude, I. (1995) "Transmission techniques for digital terrestrial TV broadcasting". *IEEE Commun. Mag.*, 33(2), 100–109.
- [33] Willink, T.J. and Witteke, P.H. (1997) "Optimization and performance evaluation of multicarrier transmission". *IEEE Trans. Commun.*, 43(2), 426–440.
- [34] Vande, J., Sandell, M., & Beorjesson, O. (1997). "ML estimation of time and frequency of OFDM systems". *IEEE Trans. Commun.*, 45(7), 1800–1805.
- [35] Pollet, T., Spruyt, P., & Moeneclaey, M. (Nov. 1994). "The BER performance of OFDM systems using non-synchronized sampling". *IEEE GLOBECOM'94*, pp. 253–257.
- [36] Tsai, Y., Zhang, G., Grieco, D. et al. (2007) "Cell search in 3GPP long term evolution systems". *IEEE Vehicular Technology Magazine*, 2(2), 23–29.
- [37] Van de Beek, J.J., Edfors, O., Sandell, M. et al. (July 1995). "Channel estimation in OFDM systems". *IEEE VTC'95*, vol. 2, pp. 815–819.
- [38] Zhao, Y. & Haggman, S.G. (2001). "Inter-carrier interference self-cancellation scheme for OFDM mobile communication systems". *IEEE Tran. Commun.*, 49(7), 1158–1191.
- [39] Lee, K.I., Woo, K.S., Kim, J.K. et al. (Sep. 2007). "Channel estimation for OFDM based cellular systems using a DEM algorithm". *PIMRC'07*.

- [40] Ochiari, H. & Imai, K. (2001) “On the distribution of the peak-to-average power ratio in OFDM signals”. IEEE Trans. Commun., 49(2), 282–289.
- [41] Ochiari, H., & Imai, K. (Dec.2000). “On clipping for peak power reduction for OFDM signals”. IEEE GTC,vol.2, pp. 731–735.
- [42] Li, X., & Cimini, L.J. (1998). “Effects of clipping and filtering on the performance of OFDM”. IEEE Commun. Letter, 2(20), 131–133.
- [43] Van, R. (Nov.1996). “OFDM codes for peak-to-average power reduction and error correction”. IEEE GTC, London, vol. 2, pp. 740–744.
- [44] Alshammari, A., Albdran, S., & Matin, M. (Oug. 2012).“Study of Bit Error Rate (BER) for Multicarrier OFDM”, SPIE optics and photonics.
- [45] Myung, H.G., Lim, J., and Goodman, D.J. (Sept. 2006).“Peak-to-Average Power Ratio of Single Carrier FDMA Signals with Pulse Shaping”. PIMRC’06, pp. 1–5.

Appendix A: Journal Publications

IOSR Journal of Engineering (IOSRJEN)

e-ISSN: 2250-3021, p-ISSN: 2278-8719, www.iosrjen.org

Volume 2, Issue 9 (September 2012), PP 91-97

Clipping and Filtering Technique for reducing PAPR In OFDM

Saleh Albdran¹, Ahmed Alshammari², Mohammad Matin³

¹(Electrical & Computer Engineering Department, University of Denver)

(smbdran@hotmail.com)

Abstract— Recently, Orthogonal Frequency Division Multiplexing (OFDM), as a multi-carrier, and a single carrier transmission systems are used widely in the communications industrial systems. Each one of these two techniques has their own advantages and disadvantages. To maintain a high data rate, OFDM is preferred over the single-carrier transmission system due to several shortages like, complexity of equalizing that increases proportionally with the data rate. To overcome this problem, OFDM is used as a transmission system with much better Bit Error Rate (BER) performance. Peak-to-Average-Power ratio (PAPR) is major drawback of using OFDM but we can deal with it using clipping and filtering as a power reduction technique.

Keywords— Additive White Gaussian Noise (AWGN), BER, high data rate, Multi-Carrier, OFDM, Single-Carrier (SC),

I. INTRODUCTION

During the last few years, the wireless communications went through several improvement stages in a fast way and as a result of that, the demand on the wireless services has growth rapidly as well. Due to the unpredictable nature of the wireless channels, calculating the propagation and the noise is not easy. On the other hand, the wired channels have less complexity of calculating the noise because that the signal propagates in a fixed path. One of the reasons to have signal degradation is the Additive White Gaussian Noise (AWGN) that could be occurred due to industrial or natural sources. There are also several types of fading channels include: multipath fading, frequency selective fading and others.

It is much easier to use single-carrier transmission scheme due to the simplicity and accuracy that is provided especially with the low data rate. This technique has its own advantages like the simplicity of transmitting the signal through a flat fading channel and saving more power since there is no need to extend the bandwidth by inserting guard interval. However, the use of single-carrier may have actual drawbacks with high data rate including equalizing complexity. Also Inter Symbol Interference (ISI) is a serious issue that appears with the multipath fading or frequency selective fading channels. OFDM is used to overcome the shortages of the single-carrier transmission scheme in the case of having high data rate [1]. The high bandwidth efficiency is one of the OFDM advantage in the case of having a big number of subcarriers. Also, with the OFDM scheme there is much lower chance to have ISI. Nevertheless, there are some OFDM drawbacks that could be the low bandwidth efficiency for having small subcarrier number. Also, we might have high peak values because of the IFFT operation in the transmitting side.

Frequency Division Multiplexing (OFDM), as a multiple carrier, outperforms the single carrier for communication systems mainly in high data rate. OFDM is getting so popular since it is less exposed to multipath effects, that makes it the core technique for the future standard systems, beside the high efficiency of its spectrum [2]. The main drawback of OFDM is the peak to average power ratio (PAPR) performance, which rises so high because of amplifiers nonlinear effects. The high PAPR essentially reduces the efficiency of the output power amplifier (PA). There are several techniques, to reduce the PAPR, which are divided into different categories: clipping technique, coding technique, probabilistic technique and so on [3] [4]. In this paper we will use clipping and filtering technique scheme to reduce the PAPR because of its easiness. However, this process could cause in-band distortion or out-of-

band radiation, which could destroy the signal or disturb the adjacent channel. The paper is organized as follow: In section II a short definition of the OFDM and the PAPR to state the main concepts. Then, a brief explanation and description of the system in section III. After that in section III there is some details regarding the clipping and filtering technique. In section IV a simulation results is placed with extended details. Finally in section V, we conclude this paper with some of our observations.

II. SINGLE-CARRIER TRANSMISSION

In Fig1, there is a block diagram for a typical end-to-end single-carrier scheme. This transmission system is contains of a band-limited channel denoted by $h(t)$, the transmit mapper $g_T(t)$, the receiver de-mapper $g_R(t)$ and equalizer symbolized by $h^{-1}(t)$. The transmitted symbols a_n have a period of T for each symbol and the data rate is presented as $R = 1/T$. The output of the process is shown in the following equations (1) and (2) where the AWGN is denoted by $z(t)$:

$$y(t) = \sum_{m=-\infty}^{\infty} a_m g(t - mT) + z(t) \quad (1)$$

$$g(t) = g_T(t) * h(t) * g_R(t) * h^{-1}(t) \quad (2)$$

We made assumption in this paper that the transmitted signal is recovered from the fading and noise effects using the equalizer. Since this assumption is made, the noise in the previous equations is ignored and the noise-free output can be formed as follow:

$$y(t) = \sum_{m=-\infty}^{\infty} a_m g((n - m)T) \quad (3)$$



Fig1: Model of single-carrier transmission system.

In the stages of mapping and de-mapping, different modulation techniques could be used. Quadrature Amplitude Modulation (QAM) and Phase Shift Keying (PSK) are used in this paper as a modulation technique. The input sinusoidal signal can be mapped to two components the In-phase component $I(t)$ and the Quadrature component $Q(t)$. To explain the concept of modulation procedure, we can take Binary PSK as an example. In the case of having BPSK, there are two possible values, 0 or 1. While, if QPSK is used, we would have two binary digits at a time, (00,01,10,11). Table1 show the mapped component represented in terms of Q and I:

Table 1: Converting binary digits to complex form.

Binary Digits	I(t)	Q(t)
00	$1/\sqrt{2}$	$1/\sqrt{2}$
01	$1/\sqrt{2}$	$-1/\sqrt{2}$
10	$-1/\sqrt{2}$	$1/\sqrt{2}$
11	$-1/\sqrt{2}$	$-1/\sqrt{2}$

III. MULTI-CARRIER (OFDM)

To over come the shortages that appear using single-carrier transmission, OFDM is used as a multi-carrier transmission [4]. Fig2 shows a block diagram for the OFDM transmission system where it has two main parts: transmitting side and receiving side. The signal gets into the transmitting side starting with mapping process. Then the output of the operation is converted from serial form to parallel form making shorter symbols sequences.

A pilot is inserted in between the sub-carrier seeking a way to estimate a start of the OFDM symbols. Afterward the output signal goes through the IFFT operation before adding the Cyclic Prefix (CP). The use of the IFFT is so important to overcome the use of huge number of RF oscillators. The last stage in the receiver is the parallel to serial converter.

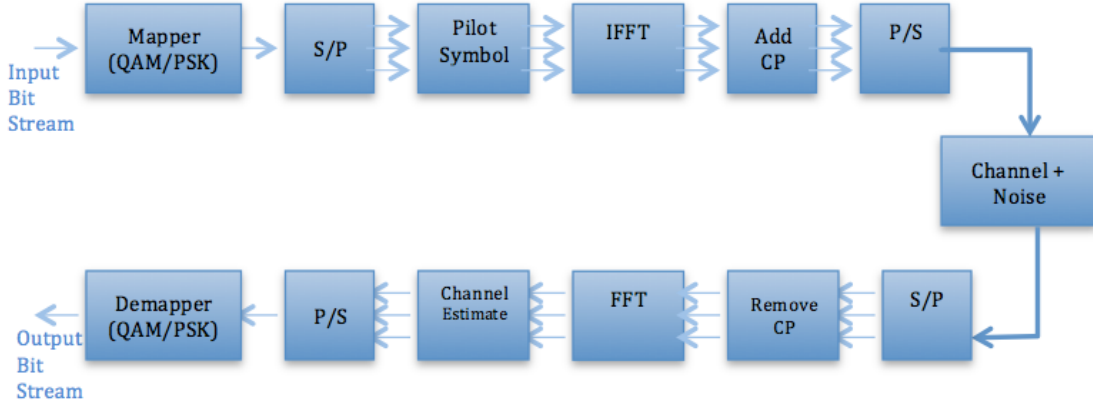

Fig2: Model of Multi-carrier transmission system (OFDM).

Orthogonality should be achieved to ensure better spectral efficiency for the system and maximum capacity for the transmitting channels. The aim of maintaining orthogonality is to prevent the overlapped of center frequency for the subcarrier and giving a chance for the spectrums of the subcarriers to overlap desiring higher spectral efficiency. Assume there is complex exponential signal $\{e^{j2\pi f_k t}\}_{k=0}^{N-1}$ that represents the subcarriers in the OFDM signal while we have $f_k = k/T_{sym}$. To check the orthogonality of any two sub-carriers in the OFDM signal, the following conditions can be applied as shown in equation (4):

$$\begin{aligned}
 \frac{1}{T_{sym}} \int_0^{T_{sym}} e^{j2\pi f_k t} e^{-j2\pi f_i t} dt &= \frac{1}{T_{sym}} \int_0^{T_{sym}} e^{\frac{j2\pi k}{T_{sym}} t} e^{-\frac{j2\pi i}{T_{sym}} t} dt \\
 &= \frac{1}{T_{sym}} \int_0^{T_{sym}} e^{\frac{j2\pi(k-i)}{T_{sym}} t} dt \\
 &= \begin{cases} 1, & \text{when } k = i \\ 0, & \text{otherwise} \end{cases} \quad (4)
 \end{aligned}$$

If the dot product of the tested signals is not equal zero, we can say that these two signals did not fulfill the orthogonality condition, otherwise the two signals are orthogonal to each other. To prevent ISI, guard intervals are used to be inserted between the OFDM symbols to avoid the overlapping that could be caused by transmitting delay. The used of guard intervals is so important to ensure a symbol full attenuating. There are several types of guard intervals: zero padding, cyclic prefix (CP) and cyclic suffix (CS). In this paper we inserted CP as guard intervals to prevent ISI. On the receiving side, the signal is down converted to get the base-band signal and we make assumption that both side of the system, the receiver and the transmitter, are synchronize in time. After that, the received signal is converted from serial to parallel form to have shorter sequence in length. Then the CP is removed from the signal preparing it to proceed through the FFT operation. In the ideal case, we would have perfect output, which is impossible in practical operations.

IV. PEAK-TO-AVERAGE POWER RATIO (PAPR)

Depends on the ratio between the maximum power of the complex pass-band signal and the mean power of it, we can calculate the PAPR. The value of PAPR can be calculated as following equation shows [7]:

$$PAPR = \frac{\max(x^2(t))}{\text{mean}(x^2(t))} \quad (5)$$

Where $x(t)$ is presented in the equation to denote the amplitude of the complex pass-band signal. To calculate the probability of having PAPR greater than the threshold value for the OFDM signal, we could use Complementary Cumulative Distribution Function (CCDF). By simulating the CCDF, we compare the theoretical values with the simulation results and the PAPR keeps increasing when the number of carriers increases. In the simulation part there is a figure showing the CCDFs of OFDM signals with different number of subcarriers.

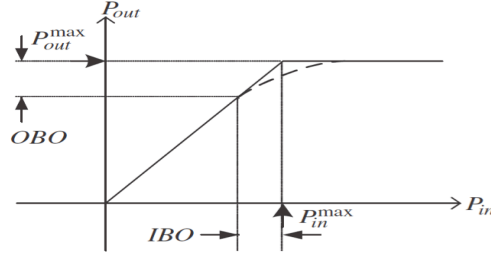

Fig3: Input and output characteristic of an HPA [5].

If we use linear amplifiers that they have larger input than the nominal value, we could have an output with a nonlinear distortion. In Fig3, there is a diagram for High Power Amplifier (HPA) showing the input and output characteristic. In this diagram, the input power is denoted by P_{in} while the outputs power is represented by P_{out} . To keep the linearity, the maximum output power is limited by the value P_{out}^{max} and the maximum input power is pounded by P_{in}^{max} . Both the input and output power are backed off to insure a linear operation and the area of the backing off is termed by Input Bach-Off (IBO) and Output Back-Off (OBO). The following two equations describe the IBO and the OBO in terms of the input-output power and the maximum input-output power:

$$IBO = 10 \log_{10} \frac{P_{in}^{max}}{P_{in}} \quad (6)$$

$$OBO = 10 \log_{10} \frac{P_{out}^{max}}{P_{out}} \quad (7)$$

In the case of having nonlinear HPA characteristic, which is caused by having larger input than its nominal value, we could have out-of-band radiation that makes an overlap between the adjacent signals [8]. Also there is another problem that appears with the nonlinear characteristic of HPA that is the in-band distortion causing a serious issues including attenuation, spinning and offset the received signals.

V. CLIPPING AND FILTERING

The clipping is the easiest technique to reduce the power by setting a maximum level for the transmitted signal [9]. Though, this technique has several disadvantages:

- The performance of BER could be affected negatively due to the in-band distortion caused by the clipping.
- Also out-of-band radiation usually appears with clipping technique that could disturb the adjacent channels.

However, we can use filtering operation to decrease the appearance of the out-of-band radiation but the signal may exceed the maximum level of the clipping operation [10]. The block diagram of clipping and filtering technique for PAPR reduction is exposed in Fig4. In this figure, N denotes the number of subcarrier and L represents the oversampling factor. In the diagram, The IFFT generate $x'[m]$ which is the L-times oversampled signal. As shown in fig4, the FFT-IFFT filter is applied to allow the signal passing through a band-pass filter (BPF) then through a low-pass filter (LPF). The outcome of the filtering stage is a less degraded BER performance and a reduced out-of-band radiation. Though, the PAPR reductions improvements are gained at the cost of regrowth the peak where the signal could go beyond the clipping level after applying the filtering operation.

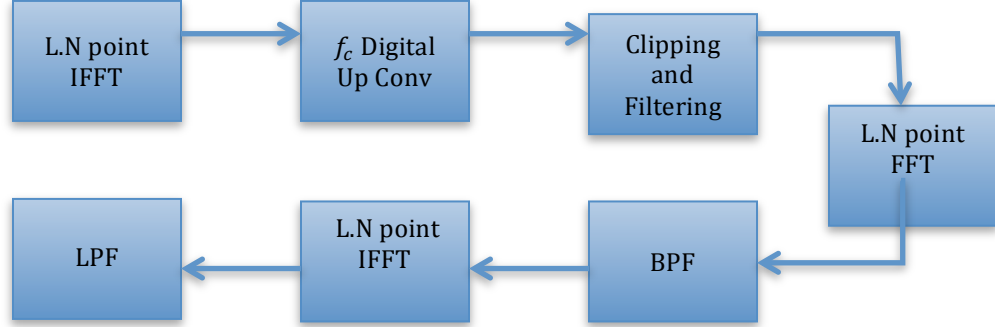

Fig4: The scheme of clipping and filtering technique for PAPR.

The signal $x^p[m]$ is the passband modulated one with carrier frequency f_c . We symbolize the clipped form of the passband-modulated signal as $x_c^p[m]$. The expression of this signal is shown in following equation:

$$x_c^p[m] = \begin{cases} -A & x^p[m] \leq -A \\ x^p[m] & |x^p[m]| < A \\ A & x^p[m] \geq A \end{cases} \quad (8)$$

Where the clipping level is denoted by A and (CR) is the clipping ratio that can be represented as follow:

$$CR = \frac{A}{\sigma} \quad (9)$$

Where the RMS value of OFDM signal is denoted by σ and it is well known that $\sigma = \sqrt{N}$ for the baseband and $\sigma = \sqrt{N/2}$ for the passband OFDM signal.

VI. SIMULATION RESULTS

The BER performance is investigated in this comparison using MATLAB code. The definition of the BER can be explained as the effected bits divided by the whole number of the transmitted bits over a time interval [11]. This calculation provides us with a percentage quantity that is a unit-less. In Fig5, there is two curves represent a comparison between the OFDM and the SC transmission systems. The comparison shows the BER performance when we use 4QAM. From the curves we can see that the OFDM transmission system improves the BER percentage compared to the SC. As we stated before, the use of the OFDM transmission has a main drawback, which is the PAPR distribution as shown in Fig6.

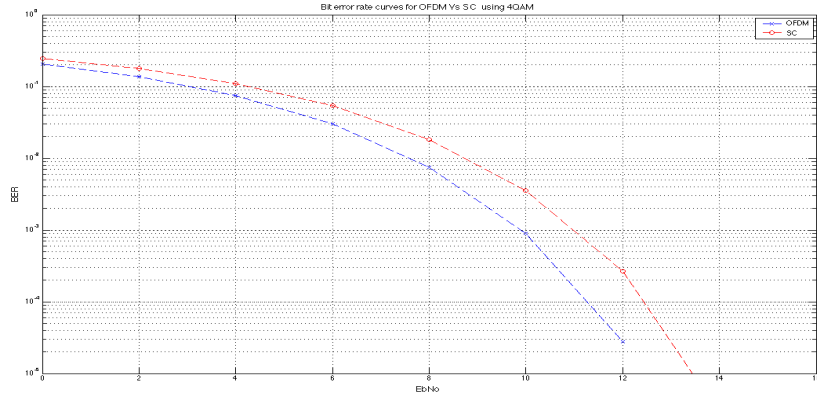

Fig5: BER curves for OFDM Vs. SC using 4QAM.

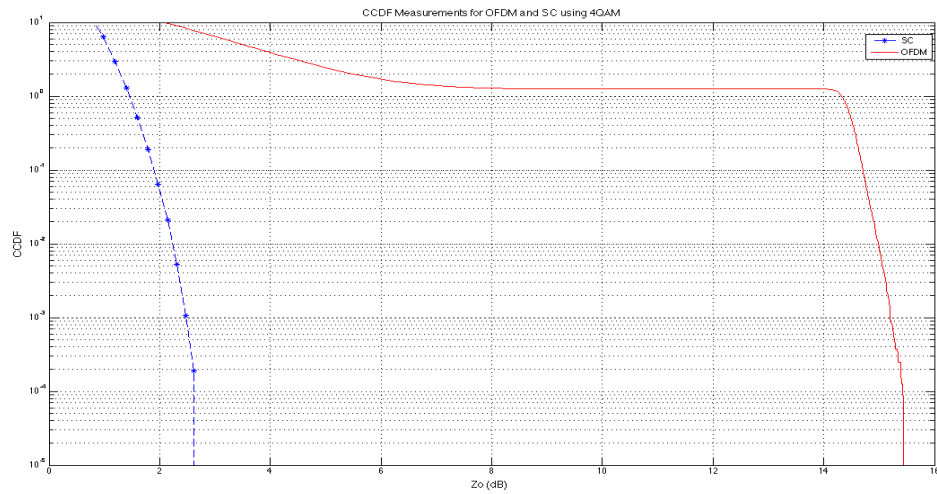

Fig6: CCDFs of OFDM Vs. SC using 4QAM.

Because crest factor (CF) is the square root of PAPR, CCDF of the CF represents the PAPR distribution. Fig7 shows CCDFs of CF of the OFDM signals after clipping with three different values for clipping ratio. There is an obvious drop in the PAPR of the OFDM signal after clipping. It can be seen as well that the highest PAPR reduction effects happens at the lowest clipping ratio. Fig7 shows that the PAPR is 14.3dB for the unclipped signal at CCDF of 10^{-1} . When we apply a clipping ratio (CR) of 1, PAPR is reduced to 5.2dB after applying this algorithm for the same values of CCDF. On the other hand, the BER performance is worsen badly as shown in Fig8 at it gets better when the CR get higher.

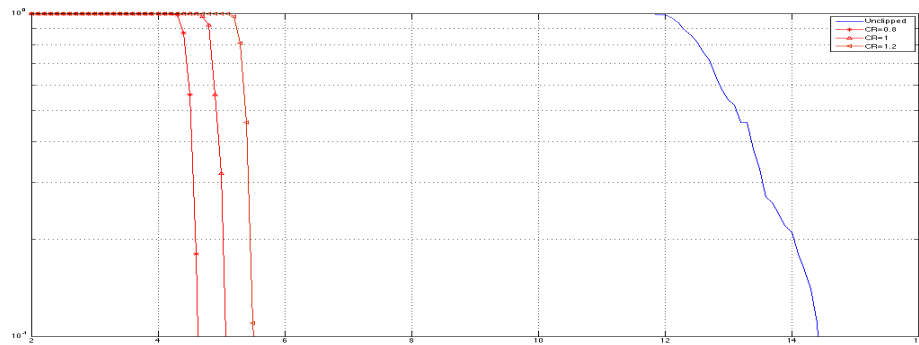

Fig7: PAPR distribution for clipped and unclipped signals.

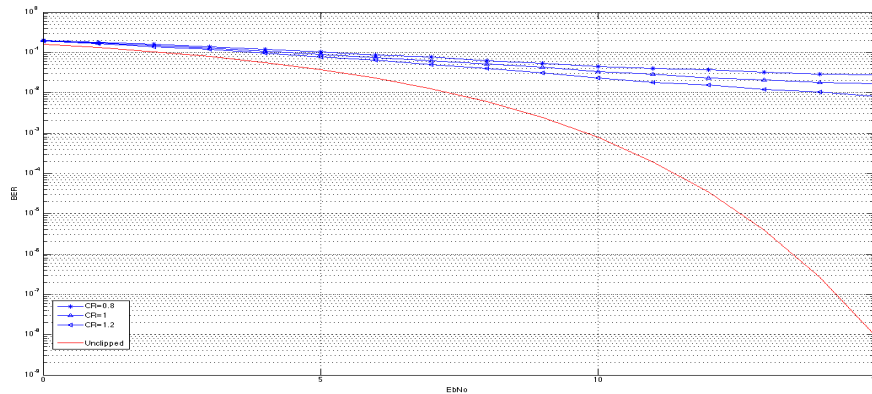

Fig8: BER for clipped and unclipped signals.

Fig9 shows the effect of the clipping and filtering on the PAPR performance where the PAPR is reduce clearly after applying this power reduction technique. The performance of BER for the clipping and filtering technique with respect to the signal to noise ratio (SNR) is compared to the unclipped OFDM signal BER as shown in fig10. Different clipping ratios have been used. It is clear that the performance of the BER get worse as the CR gets lower. The BER of the clipped and filtered signal is 0.0039 at 10 dB SNR when the clipping ratio is 1.2. The curves also show that the BER of the clipped signal is 0.0019 for the same clipping ratio and SNR.

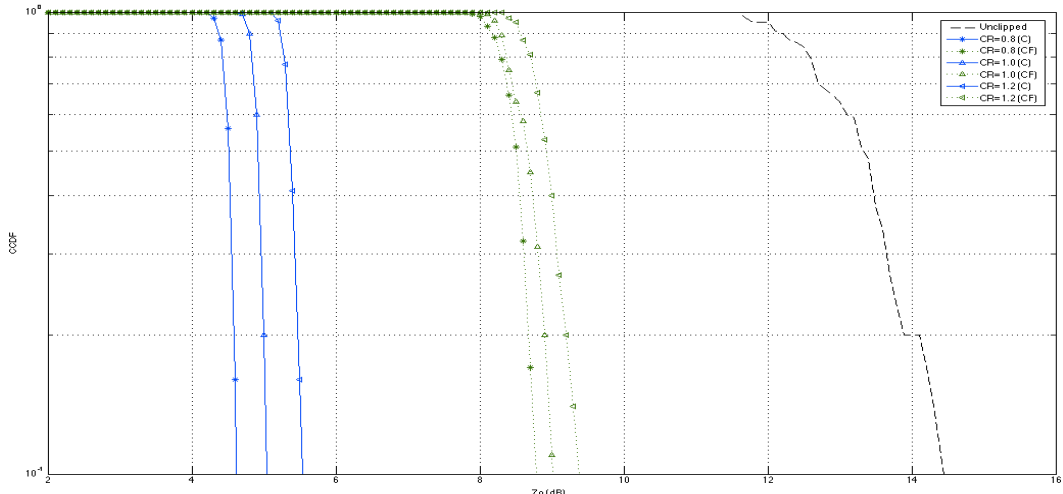

Fig9: PAPR distribution for clipped, filtered, and unclipped signals.

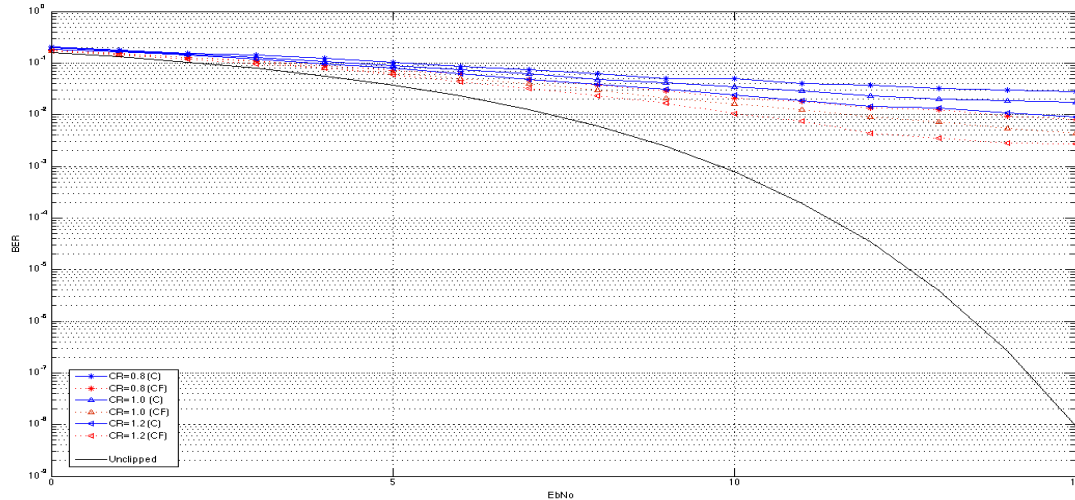

Fig10: BER for clipped, filtered, and unclipped signals.

VII. CONCLUSION

In this paper, the BER performance is investigated and analyzed for the OFDM and the single-carrier transmitting schemes to compare between them. For the both techniques, the same parameters are used to make a reasonable comparison and the two signals went through the same channel (AWGN). From the results, we have noticed that the BER performance is improved using the OFDM and outperforms the single-carrier performance. Though, there is a major drawback for using OFDM, which is the high PAPR. This problem can be reduced by using clipping and filtering, as a power reduction technique. The performance of clipping and filtering technique to has been studied in this paper. We conclude from our results that PAPR reduces more at lower CR. The results show how clipping and filtering affect the BER of an OFDM signal and it is clear that the BER is increased after this process. Filter is used to decrease the distortion that result from clipping.

REFERENCES

- [1] A. John, Multicarrier Modulation for Data Transmission: An Idea Whose Time Has Come. *IEEE Communications Magazine*, 1990.
- [2] S. Albdran, A. Alshammari, and M. Matin, The Sensitivity of Bit Error Rate (BER) Performance in Multi-Carrier (OFDM) and Single-Carrier, *SPIE optics and photonics*, 2012.
- [3] J. Tubbax, OFDM versus Single Carrier: A Realistic Multi- Antenna Comparison, *EURASIP Journal on Applied Signal Processing*, 2004, 1275–1287.
- [4] R. Nee, and R. Prasad, OFDM for wireless multimedia communications, *Boston, MA: Artech House*, 2000.
- [5] Y. Cho, J. Kim, W. Yang, and C. Kang, *MIMO-OFDM wireless communication with MATLAB* (Singapore, Wiley, 2010)
- [6] A. Bahai, B. Saltzberg, and M. Ergen, Multi carrier digital communications: Theory and applications of OFDM, *Springer Science, New York*, 2004.
- [7] A. Saleh, R. Valenzuela, A Statistical Model for Indoor Multipath Propagation, *IEEE Journal on selected Areas in Communications*, 1987, 128-137.
- [8] H. Ochiai, and H. Imai, On the Distribution of the Peak to Average Power Ratio in OFDM Signals, *IEEE Trans. Commun*, 2001.
- [9] S. Han, and J. Lee, An overview of peak-to-average power ratio reduction techniques for multicarrier transmission, *IEEE Wireless Communications*, 2005, 56-65.
- [10] B. Alhasson, and M. Matin, Reduction of PAPR for OFDM Downlink and IFDMA Uplink Wireless Transmissions, *International Journal of Computer Science and Information Security*, 2011.
- [11] A. Alshammari, S. Albdran, M. Matin, Study of Bit Error Rate (BER) for Multicarrier OFDM, *SPIE optics and photonic*, 2012.

Effects of Fading Channels on OFDM

Ahmed Alshammari, Saleh Albdran, and Dr. Mohammad Matin

Department of Electrical and Computer Engineering University of Denver

Abstract—One of the essential components of recent communications is Orthogonal Frequency Division Multiplexing (OFDM). Handling bad conditions, high bandwidth and using the available spectral efficiently are some of its characteristics. Hence, it has replaced old communication technologies in many systems such as wireless networks and 4G mobile communications. In this paper, Effects of fading channels on OFDM are investigated. MATLAB is used to simulate wireless fading channels environments that are either based on Doppler spread or Delay Spread.

Key Words— OFDM, ISI, BER, PSNRs

I. INTRODUCTION

High data rates are demanded a lot in modern communications. It is the huge development in the communications industry that led to this demand. Also, better quality and lower BER became more important. OFDM technique, which was introduced in the 1960's, provides all that [1][2]. It was not practical at that time because technologies to apply did not exist then e.g. it was not possible to have processors that can perform IFFT and FFT. In the 90's many of those problems were solved and OFDM started getting more popular since then.

Multi carrier modulation is the backbone of the OFDM technique. Hence, data are split to many parallel streams, which decreases bit rate. OFDM system of modulates several subcarriers using these parallel sub streams. OFDM's ability to transmit data with high speed is the main reason it is getting so popular besides robustness against Inter symbol interference (ISI). Therefore, many wireless and wired communication standards around the world have adopted this kind of modulation.

OFDM system model used in this paper is shown in Figure 1. Series to parallel conversion of the data stream results in the blocks of data symbols that we are transmitting. Assuming that N is the number of these blocks then OFDM symbols are characterized by $X_m = (x_{0,m} \ x_{1,m} \ \dots \ x_{N-1,m})^T$. After that each one of the symbols modulates one subcarrier. A guard band of length N_{cp} is attached to each OFDM symbol. The m^{th} OFDM symbol is given by equation (1).

$$S_m(n) = \begin{cases} \frac{1}{N} \sum_{k=0}^{N-1} x_{k,m} e^{\frac{j2\pi k(n-N_{cp})}{N}} & \text{for } n \in [0, N + N_{cp} - 1] \\ 0 & \text{otherwise} \end{cases} \quad (1)$$

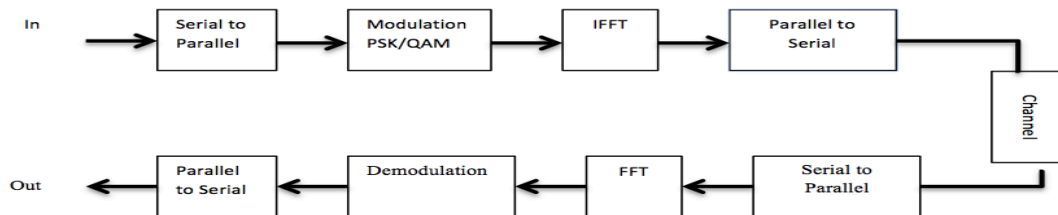

Figure 1 Block diagram of the OFDM system

Equation (2) represents the received signal $r(n)$ [3]. We can notice that the received signal is the summations of the white Gaussian noise (AWGN) $n(n)$ and the convolution of the channel's impulse response $h(n)$.

$$r(n) = \sum_{\eta}^{n_{cp}-1} h(\eta)s(n-\eta) + n(n) \quad (2)$$

II. FADING

Communication channel is the medium that connects the transmitter and the receiver. Channels could vary according to the nature of the system. The loss in the signal as it approaches the receiving side is caused by random attenuations. In wireless environment, it is possible that signals propagate through two or more paths before reaching the receiver in a phenomenon that is known as multipath propagation. There are many reasons that can cause multipath such as atmospheric conditions or lack of direct path. Phase shifting, destructive and constructive interference are some of the consequences of this phenomenon [4]. Hence, received signal could have different amplitude and phase because of change in the propagation time and the intensity distribution of the waves [5].

2.1 Small Scale Fading

Small scale fading is controlled by the nature of the sent signal and communication environments. Symbol duration, Bandwidth and channel parameter are factors that decide the type of fading channel. Small scale fading could be divided into two main categories as shown in figure 2:

1) Fading Due To Delay Spread: Delay spread can cause two types fading that are either frequency selective slow and frequency selective fast fading [5]. Flat fading is the most popular types of fading. It occurs when the bandwidth of the signal is less than the bandwidth of the channel. The power of the signal is reduced in this case as a consequence to the gain variation of the channel when the spectrum remains the same. In frequency selective fading: linear phase response and constant gain are the main characteristics. Bandwidth of the channel is smaller than that of the signal, which is distorted by frequency selective, fading due to the multiple version of the signal with various amplitudes that are received.

2) Fading From Doppler Spread: it is either flat slow or flat fast fading caused by Doppler spread. In slow fading, symbol period is more than coherence. In Fast Fading, impulse response of the channel variations are very fast i.e. symbol duration of the transmitted signal is more than the coherence time.

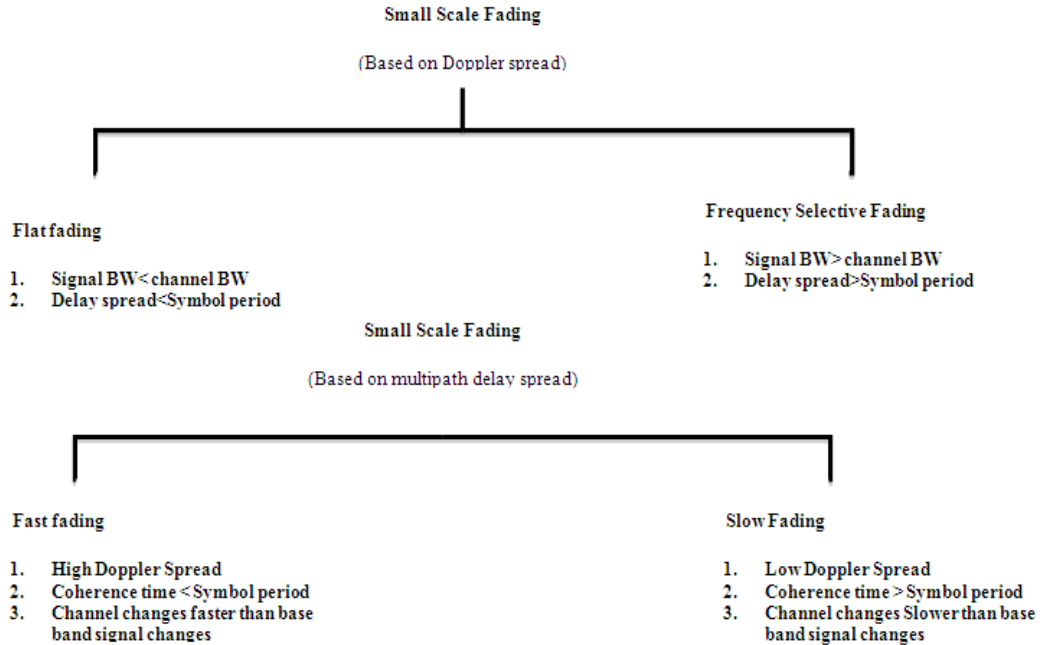

Figure 2 Small Scale Fading

2.2 Factors affecting fading:

Four things could affect small scale fading:

- 1) Mobile speed: moving mobile could experience positive or negative Doppler shift. When the mobile moves closer to the transmitting side positive Doppler spread happened while Negative Doppler spread occurs the other way around.
- 2) Multipath Propagation: Signal energy is consumed by phase, amplitude and time in multipath environment. Multiple versions of the signal with various arriving instants and shifted spatial orientation. The duration that the signal takes to get to the receiver is increased in multipath channels.
- 3) Bandwidth of The Channel: When the bandwidth of the channel is less than that of the signal transmitted, it gets distorted. The channel transfer function must be flat in order for its bandwidth to be coherent. Transfer function of the channel is flat whenever the phase response is linear with a constant gain [6].
- 4) Velocity of objects within the channel: Objects in the communication environment sometimes are moving. If that movement is of a speed that is more than that of the receiver, small-scale fading happens otherwise we can ignore those movements.

III. CHANNEL MODELING

Time variant impulse response of the channel is used to model it. Motion of the receiver is the variable that affects time changing. Equation (3) calculates the received signal.

$$y(d, t) = \int_{-\infty}^t x(\tau)h(d, t - \tau)d(\tau) \quad (3)$$

Where $h(d, t)$ is the impulse response of the channel and $x(t)$ is the signal. If $d = vt$ is the position of the receiver and v is a constant, it is possible to replace d in equation (3) with vt as in equation (4).

$$y(vt, t) = \int_{-\infty}^t x(\tau)h(vt, t - \tau)d(\tau) \quad (4)$$

$$h_b(t, \tau) = \sum_{i=0}^{N-1} a_i(t, \tau)e^{j(2\pi f_c \tau_i(t) + \varphi_i(t, \tau))} \delta(\tau - \tau_i(t)) \quad (8)$$

Channel impulse response can be found using (5). Where, $a_i(t, \tau)$ are the amplitudes and $\tau_i(t)$ are the delays whereas $\theta_i(t, \tau) = 2\pi f_c \tau_i(t) + \varphi_i(t, \tau)$ represent phase shift in the i th component.

The impulse response can be found using equation (9) for time invariant channel where every multipath components of that channel have delay.

$$h_b(\tau) = \sum_{i=0}^{N-1} a_i(t, \tau)e^{j\theta_i(t, \tau)} \delta(\tau - \tau_i(t)) \quad (9)$$

3.1 Clarke's Model

Clarke's Model relies on scattering to discover the statistical characteristics of the channel. Beside the assumption of fixed transmission antenna that is vertically polarized, N normalized plane waves of the antenna with a random carrier phases angles of arrival are assumed while amplitude remains unchanged. When the receiver is moving, m_{th} wave that has arriving angle α_m with respect to the x-axis. Doppler shift is given by equation (10).

$$f_m = \frac{v}{\lambda} \cos \alpha_m \quad (10)$$

Where, λ is the wavelength of incident wave.

Every received wave has a different carrier frequency with small shift from the center frequency. The power spectral density of the output is given by equation 11. It is clear from that equation that the PDF is zero when $|f - f_c| > f_m$. With center frequency f_c , Spectrum is limited to $\pm f_m$ and all the received waves has different carrier frequencies that are shifted.

$$S(f) = \frac{A[q(\alpha)G(\alpha) + (-\alpha)G(-\alpha)]}{f_n \sqrt{1 - (\frac{f - f_c}{f_m})^2}} \quad (11)$$

Assuming a vertical $\frac{\lambda}{4}$ antenna, $G(\alpha) = 1.5$ and $p(\alpha) = \frac{1}{2\pi}$ over 0 to 180° , then $S(f)$ becomes as in equation (12).

$$S(f) = \frac{1.5}{\pi f_m \sqrt{1 - (\frac{f-f_c}{f_m})^2}} \quad (12)$$

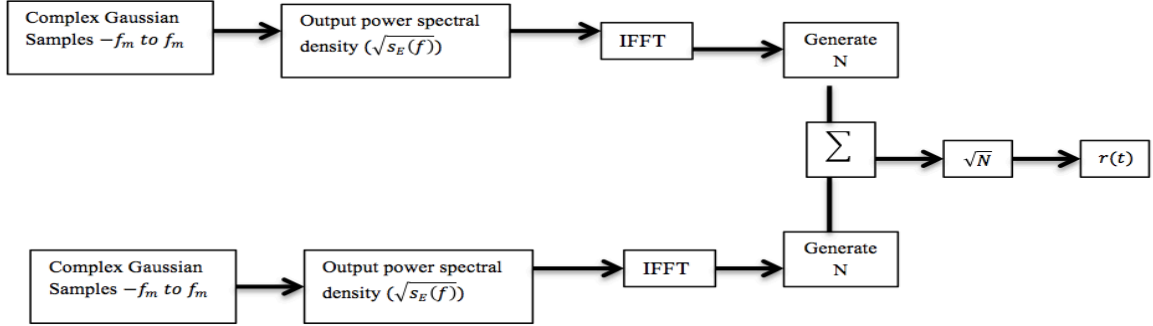

Figure 3 Rayleigh fading implementation

The block diagram in figure 3 was used to simulate Rayleigh fading in the frequency domain. First, The signal is modulated with In-phase & quadrature modulation. Thus, two independent Gaussian low pass noise components are used to create these components. IFFT is implemented as the last step in the simulation process in order to shape the random signal.

The simulator in figure 3 is impended according to the following steps [5]:

- Determine the number of points in frequency domain N which describes the square root of PDF $\sqrt{S_{E_z}(f)}$ and the max Doppler frequency shift f_m should be specified as well.
- Find out the time duration of the fading waveform that is given by $T = \frac{1}{\Delta f}$.
- Create complex Gaussian Radom variables for each $\frac{N}{2}$ positive frequency components.
- Conjugate positive frequencies in order to find the negative ones.
- Multiply the in-phase and quadrature components by fading spectrum $\sqrt{S_{E_z}(f)}$
- Apply IFFT on the in-phase and quadrature components in order to obtain two N times series. Sum the squares of each signal point.
- Take the square foot of the summation done in the previous step in order to obtain the N Pint time series with the Doppler spread and the time correlation for the Rayleigh fading.

IV. RESULTS

OFDM technique is studied over wireless communication environment to examine the effects of fading. MATLAB to simulate the process of transmitting image signals over fading channels with various SNRs. OFDM model discussed in the first part of this paper was followed and Fading channels were implemented according to Clarke's model. It assumes that there is no line of sight between transmitter and receiver ends. For flat and frequency selective fading, the speed of the receiver was either slow 3-miles/hour or fast 100-miles/hour. 3 Miles/hour was assigned as the speed of the receiver for the purpose of simulating Small Doppler Spread and 100 Miles/hour was used to simulate large Doppler Spread. Figures 4 and 5 shows images sent over Flat slow Fading and Flat Fast Fading channels respectively with different SNRs. It is clear that quality of the received signals is improved at higher SNRs. Also, images have more distractions at higher speeds of the receiver. Therefore, the OFDM system delivers better images than over flat slow fading.

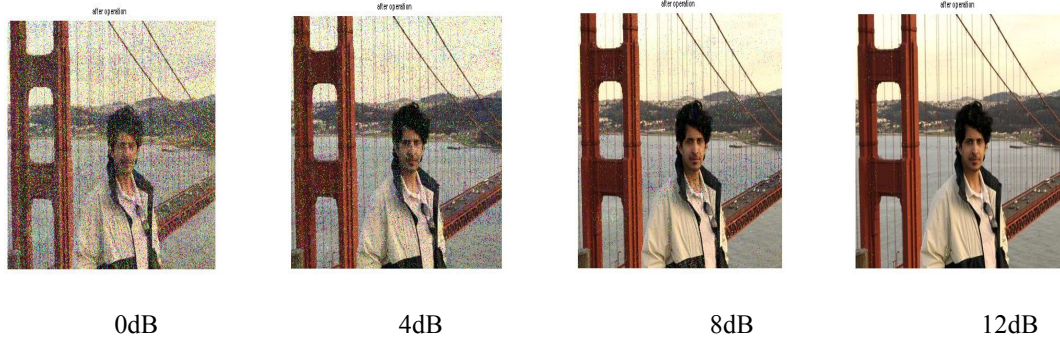

Figure 4 Image sent Over Flat Slow Fading Channel with Different SNRs

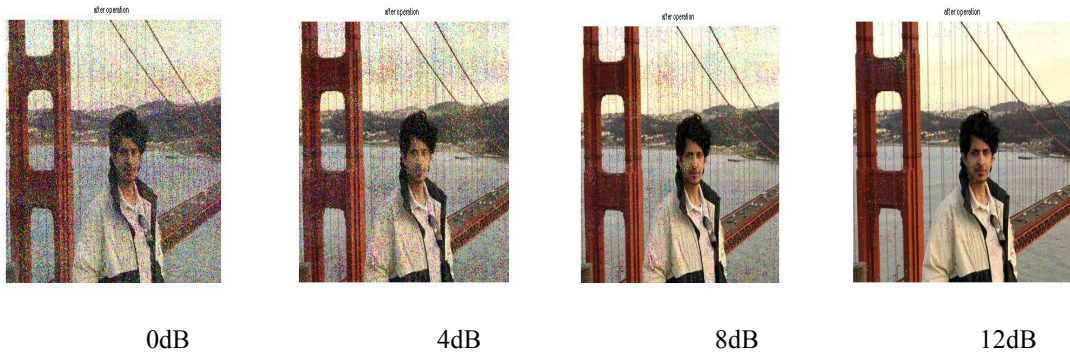

Figure 5 Image sent Over Flat Fast Fading Channel with Different SNRs

For Frequency selective fading environment, Multiple Clarke's model was used. Multiple delayed versions of the transmitter signal are subjected to Clark's model to simulate frequency selective fading. 4 different paths are assumed with delay of 0,4,8 and 16 samples. As done in flat fading, 3 Mile/hour mobile speeds was used in the simulation for frequency selective slow fading and 100 Mile/hour speed was used to simulate Frequency Selective Fast Fading. Figures 6 and 7 shows BER over Frequency Selective Slow Fading and Frequency Selective Fast Fading respectively.

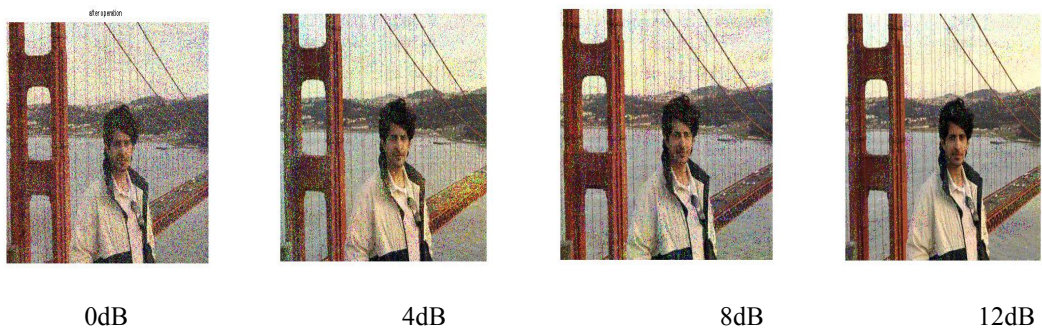
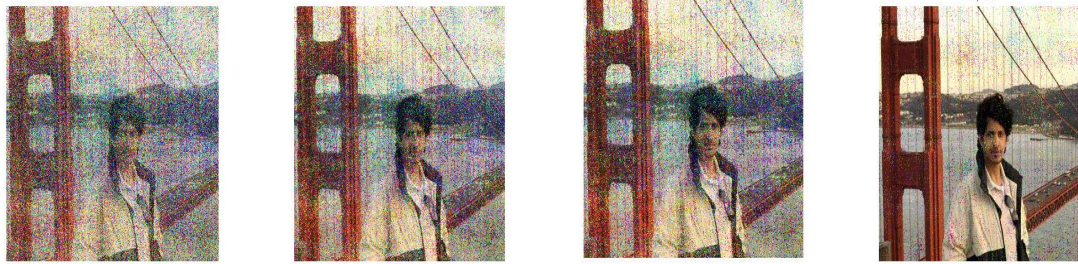

Figure 6 Image sent Over Frequency Selective Slow Fading Channel with Different SNRs

Similarly, Quality of the received images is improved at higher SNRs for frequency selective fading channel. However, images have more distractions at high receiver speeds. Therefore, OFDM system delivers better images over Frequency Selective slow fading than frequency selective fast fading when the speed of the receiver is increased.



0dB 4dB 8dB 12dB
 Figure 7 Image sent Over Frequency Selective Fast Fading Channel with Different SNRs

OFDM system shows a better performance over flat fading than frequency selective fading. Also, the quality of the received signal is less when the mobile is moving with higher speeds. BER of the four kinds of Fading are shown in figure 8. It is clear that the signal received in frequency selective fading channel environment has more BER than the one that is received in flat fading channel environment.

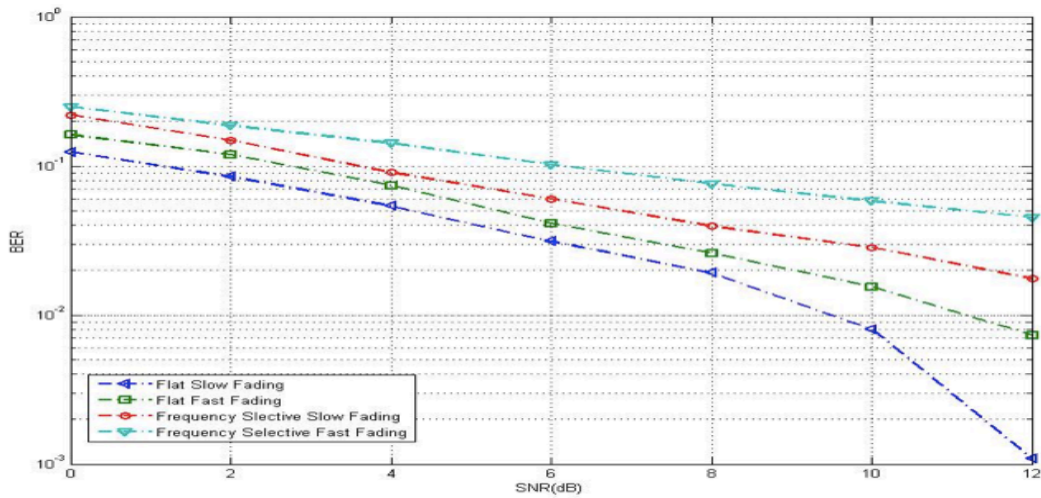

Figure 8 Comparing BER of The Different Channels

Peak-Signal-to-Noise Ratio (PSNR) is used to measure reconstruction quality of the received signal. It is simply the ratio between the power of the original signal and the power of the disturbing noise that affect the quality of the received signal. PSNRs curves for the received images are shown in figure 9. We can see the OFDM System delivers images with more PSNRs flat fading channel than in frequency selective fading channel.

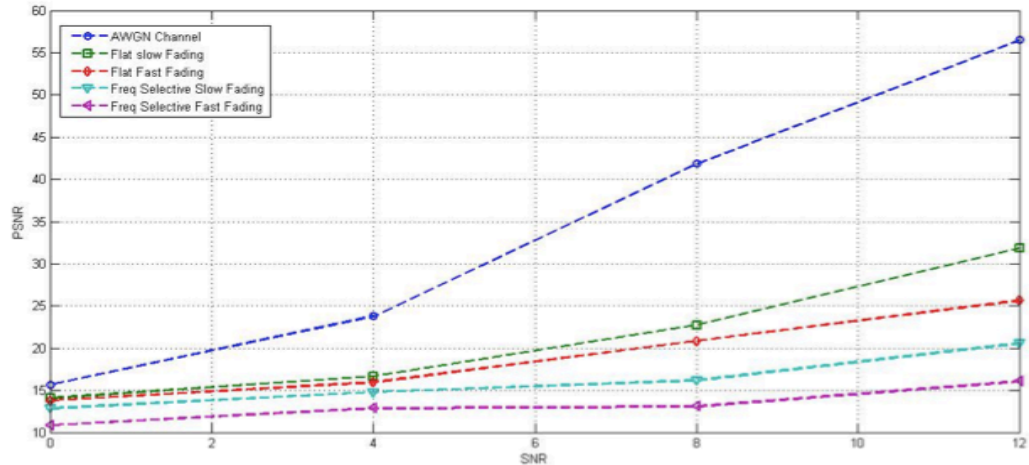

Figure 9 Comparing PSNR of The Different Channels

V. CONCLUSION

OFDM systems are very efficient in handling bad conditions and high data rates. Fading channels, however, are very common in wireless communications. They affect the process of signal reception after causing losses in transmitted signal. These effects that fading channels have on the performance of OFDM systems are investigated. MATLAB was used to simulate wireless fading channels that are either based on Doppler spread or Delay Spread. Quality of received images, BER, PSNRs is the aspects used to evaluate the extent of these effects. In conclusion, fading that is caused by delay spread caused less distortion than fading that result from Doppler spread. We found that Distortion to the received signal is higher when the speed of the receiver is increased.

VI. REFERENCES

- [1] BBC Research Department, E. D. An introduction to digital modulation and OFDM techniques, 1993.
- [2] Y. Cho, J. Kim, W. Yan, & C. Kang, *MIMO-OFDM wireless communications with MATLAB*. (Singapore: Wiley, 2010).
- [3] R. Frederiksen, F. Prasad, An overview of OFDM and related techniques towards development of future wireless multimedia communications, *IEEE Radio and Wireless Conference Proceedings*, 2002.
- [4] W. Spring, & T. Mathur, Small scale fading in radio propagation, 2005.
- [5] T. Rappaport. *Wireless Communication*. (Upper Saddle River, NJ: Prentice Hall, 1996).
- [6] J. C. Chuang, The effects of time delay spread on portable radio communications channels with digital modulation, *IEEE journal on selected areas in communications*, 1987.
- [7] V. Jeyasri, Mobile communications, India: Technical Publications Pune, 2009.
- [8] M. Engels. *Wireless OFDM systems 2* (Boston: KLUWE Academic, 2002).
- [9] S. Gayatri, P. Prabhu, & M, Shankar, Simulation of flat fading using MATLAB for classroom instruction. *IEEE TRANSACTIONS ON EDUCATION*.
- [10] K, SANKAR. Understanding an OFDM transmission, 2008. Retrieved April 15, 2012, from <http://www.dsplog.com/2008/02/03/understanding-an-ofdm-transmission>
- [11] K. Lee, H. Lee, N. Chang, and J. Kang, Design of novel orthogonal space-time-frequency block codes for OFDM systems Over Fading Channel Environments, *Proc. IEEE 66th Vehicular Technology Conference*, 2007, pp. 521–525.

Appendix B: Conference Proceedings

Study the Sensitivity of Bit Error Rate (BER) Performance in Multi-Carrier (OFDM) and Single-Carrier

Saleh Albdran, Ahmed Alshammari, Mohammed Matin.
Department of Electrical and Computer Engineering
University of Denver

Abstract

Recently, the single-carrier and multi-carrier transmissions have grabbed the attention of industrial systems. Theoretically, OFDM as a Multicarrier has more advantages over the Single-Carrier especially for high data rate. In this paper we will show which one of the two techniques outperforms the other. We will study and compare the performance of BER for both techniques for a given channel. As a function of signal to noise ratio SNR, the BER will be measure and studied. Also, Peak-to-Average Power Ratio (PAPR) is going to be examined and presented as a drawback of using OFDM. To make a reasonable comparison between the both techniques, we will use additive white Gaussian noise (AWGN) as a communication channel.

Key words: Single-Carrier (SC), Multi-Carrier, OFDM, BER, SNR, high data rate, Additive White Gaussian Noise (AWGN), IFFT, FFT.

1. Introduction

During the last decade, the wireless communications have been improved rapidly and as a result of that, the demand on the wireless communication devices have growth as well. The nature of the wireless channel, that is unpredictable, leads to more difficulties of calculating its noise and the propagation. Unlike the wireless channels, the wired one has less complexity of determining the noise due to the fixed path that the signal propagates through. There are several reasons for the signal to have degradation and one of them is called AWGN, which caused by either natural or industrial sources. Also, there is another common source called multipath fading, which is classified among the small-scale fading category. The reason to have this kind of fading is the natural or even industrial huge surfaces where the signal is reflected or scatted while it should ideally propagate directly to the receiver in case of not having obstacles.

The use of single-carrier transmission scheme provides easiness and accuracy while using low data rate. This type of transmission scheme has it own advantages and disadvantages. The single-carrier transmission is simple in case of having a flat fading channel also there is no need to increase the bandwidth of the signal by inserting a guard interval, unlike the multi-carrier technique. On the other hand, the single-carrier transmission has several drawbacks for instance, the complexity of equalizing which increases proportionally with the data rate. Another disadvantage is the suffering of Inter Simple Interference (ISI) that occurs when there is a multipath fading in the wireless channel or equivalently if the signal propagates through a frequency-selective fading channel.

In the case of having high data rate, the use of single-carrier might have several shortages and to overcome these problems, OFDM technique, as multi-carrier transmission, is proposed to transmit the signals [1]. The use of OFDM has several advantages; one of them is the high bandwidth efficiency while transmitting a large number of subcarriers. Also it is useful to use the multi-carrier scheme to overcome the ISI problems that occurred during the multipath or frequency-selective fading channels. Despite the advantages, this scheme has its own drawbacks such as having low bandwidth efficiency for a small number of subcarrier or having high peak values due to the use of IFFT and the addition of many subcarrier components. OFDM has IFFT in the transmitting side and FFT in the receiving side. Before converting the data from series to parallel, a modulation technique such as phase shift keying PSK and quadrature amplitude modulation QAM will be applied to the signal [2]. The same thing will be done to the receiving side to demodulate the signal.

2. Single-Carrier Transmission

A typical end-to-end single-carrier transmission system is shown in Figure.1. This configuration consists of a band-limited channel $h(t)$, the transmit mapper $g_T(t)$, the receiver de-mapper $g_R(t)$ and equalizer $h^{-1}(t)$. The transmitted symbols are denoted by a_n , each one of these symbols has a period of T and data rate of $R = 1/T$. The following equations shows the equalizer output where the additive noise is denoted by $z(t)$ and the other one shows the impulse response for the whole system which is denoted by:

$$y(t) = \sum_{m=-\infty}^{\infty} a_m g(t - mT) + z(t) \quad (1)$$

$$g(t) = g_T(t) * h(t) * g_R(t) * h^{-1}(t) \quad (2)$$

In this paper we assume that the signal is completely recovered from the channel effect using the equalizer. As a result of this assumption, we ignore the noise in the previous equation of the equalizer output and the noise-free equation can be represented as follow:

$$y(t) = \sum_{m=-\infty}^{\infty} a_m g((n - m)T) \quad (3)$$



Figure1: Model of single-carrier transmission system.

In the mapping and de-mapping stages, two different modulation techniques are used. The amplitude modulation is represented by QAM and the binary modulation is demonstrated by PSK. To clarify the idea behind these procedures, we will go through the PSK and explain its concept. The input signal usually has a sinusoidal shape and it can be mapped into another form where $I(t)$ denotes the In-phase component and $Q(t)$ denotes the Quadrature component. In the case of using Binary Phase Shift Keying (BPSK) as a modulation type, we would have two possible values, either 0 or 1. On the other hand, the QPSK would have four possible values, two binary digits at a time, (00,01,10,11) and the following table shows how to represent them in terms of Q and I:

Binary Digits	I(t)	Q(t)
00	$1/\sqrt{2}$	$1/\sqrt{2}$
01	$1/\sqrt{2}$	$-1/\sqrt{2}$
10	$-1/\sqrt{2}$	$1/\sqrt{2}$
11	$-1/\sqrt{2}$	$-1/\sqrt{2}$

Table 1: Converting binary digits to complex form.

3. Multi-Carrier Transmission (OFDM)

OFDM is used as a multi-carrier transmission scheme to overcome the shortages and the problems that appear during the single-carrier transmission [4]. The block diagram of the OFDM transmission scheme is shown in Figure.2 and it has two main parts: transmitter and receiver. Mainly, the transmitter has a mapper where the signal is modulated there by either digital or analog modulation technique. As mentioned in the previous section, MPSK modulation technique is going to be used in this paper with different order numbers. After mapping the signal, a serial to parallel conversion is applied to the signal to make shorter sequences with lower number of symbols. Pilot insertion is used in this scheme by fitting reserved sub-carrier in between the sub-carrier that carried information. The point of inserting these pilots is to estimate the start of the OFDM symbol on the receiving side also to make equal distribution for the noise over the entire signal. To create OFDM symbols we need a way to solve the problem of using of huge number of RF oscillator. To overcome this issue, the inverse Discrete Fourier Transform can be applied to generate the OFDM symbols and to speed up the process, FFT can be used.

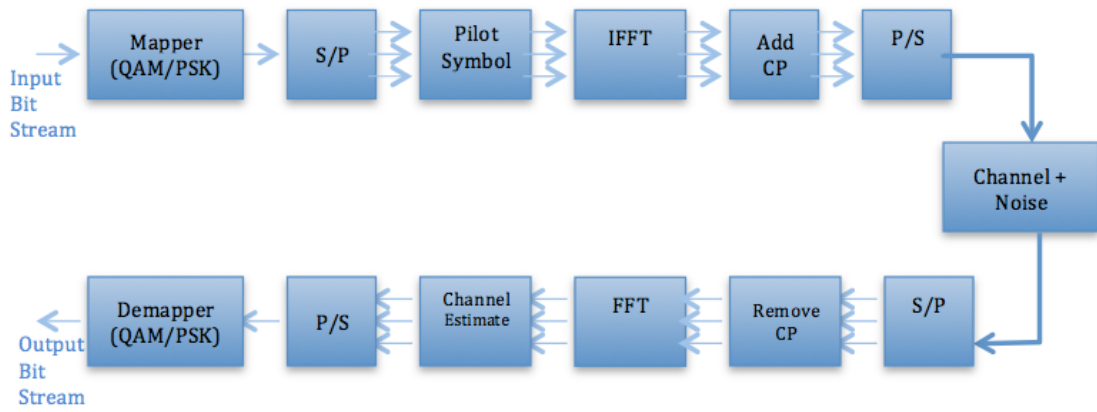

Figure2: Model of Multi-carrier transmission system (OFDM).

Orthogonality must be maintained to insure better spectral efficiency and maximum capacity. The reason of applying orthogonality is to keep the center of the subcarrier from being overlapped and letting the spectrums of the subcarriers overlapping to get higher efficiency of the spectral. Assume we are having complex exponential signal $\{e^{j2\pi f_k t}\}_{k=0}^{N-1}$ that represents the subcarriers in the OFDM signal where $f_k = k/T_{sym}$. To check whether any two sub-carriers in the OFDM signal are maintaining the orthogonality or not, we can apply the following conditions in equation (4):

$$\begin{aligned} \frac{1}{T_{sym}} \int_0^{T_{sym}} e^{j2\pi f_k t} e^{-j2\pi f_i t} dt &= \frac{1}{T_{sym}} \int_0^{T_{sym}} e^{\frac{j2\pi k}{T_{sym}} t} e^{-\frac{j2\pi i}{T_{sym}} t} dt \\ &= \frac{1}{T_{sym}} \int_0^{T_{sym}} e^{\frac{j2\pi(k-i)}{T_{sym}} t} dt \\ &= \begin{cases} 1, & \text{when } k = i \\ 0, & \text{otherwise} \end{cases} \end{aligned} \quad (4)$$

Where if the dot product of the two signals is equal to zero we can say that the two signals are orthogonal to each other. This term of orthogonality is so useful in term of preventing interfering in the carriers and avoiding Inter Carrier Interference (ICI). We can express the previous equation in the discrete time domain at $t = nT_s = \frac{nT_{sym}}{N}$, and the value of n goes from 0 to N-1 as equation (5) shows:

$$\begin{aligned}
\frac{1}{N} \sum_{n=0}^{N-1} e^{\frac{j2\pi k}{T_{sym}} n T_s} e^{-\frac{j2\pi i}{T_{sym}} n T_s} &= \frac{1}{N} \sum_{n=0}^{N-1} e^{\frac{j2\pi k}{T_{sym}} n T/N} e^{-\frac{j2\pi i}{T_{sym}} n T_s/N} = \\
&= \frac{1}{N} \sum_{n=0}^{N-1} e^{\frac{j2\pi(k-i)}{N} n} \\
&= \begin{cases} 1, & \text{when } k = i \\ 0, & \text{otherwise} \end{cases}
\end{aligned} \tag{5}$$

To avoid Inter Symbol Interference (ISI), guard intervals are inserted in between the OFDM symbols avoiding the overlapping between the symbols due to the delay in one of the transmitted symbols. The use of guard interval insures a full attenuation for the symbol and keeping the next symbol away. There are several ways to implement the concept of guard intervals insertion; one of them is the zero padding where the guard interval is nothing more than a null signal. The other two techniques are similar to each other and called cyclic prefix (CP) and cyclic suffix (CS). In this paper CP is used to maintain the wanted prevention against the ISI. In the CP technique, a cyclic extension is copied from the OFDM symbol and inserted at the front. The duration of the OFDM symbol T_{sub} is increased by the cyclic prefix duration T_G making the final duration of the OFDM symbol equals to T_{sym} as equation (6) shows:

$$T_{sym} = T_{sub} + T_G \tag{6}$$

The parallel OFDM symbols should be converted to serial symbols preparing the OFDM signal to be up-converted which is the last stage in the transmitting side. . The duration of the converted OFDM symbol, which is coming out of the parallel to serial convertor operation, is denoted by X_{len} , while the duration length of the OFDM symbol in the parallel form before proceeding through the convertor is equal to $T_{sub} + T_G$. Assuming that the number of OFDM symbols is denoted by M, we can apply the operation shows in equation (7) to find the duration of the of the converted OFDM symbol X_{len} as follow:

$$X_{len} = M(T_{sub} + T_G) \tag{7}$$

On the receiving side, the received signal is down converted to extract the base-band signal out of it by assuming that both of the receiver and the transmitter are in time synchronization. Then, the received signal converted from serial form to parallel form with shorter sequence length. After removing the cyclic prefix interval that are inserted in the transmitting side, the signal goes through the FFT operation to extract the sub-carriers values without using huge number of filters and oscillators. The output of the FFT operation is de-mapped using PSK modulation technique and this stage is the last one on the receiving side. If we have a perfect transmitter and receiver, we might have identical input and output, which is practically impossible. There are some reasons to not have perfect modulation scheme one of them is the errors of the residual equalization that cause mismatch between the transmitter and receiver in terms of phase shift and the value of the amplitude [5].

4. Noise and Channel Fading

The nature of the wireless channel affects the performance of the wireless system in a bad way. Unlike the wired communication systems, It is so difficult to do exact calculation for the noise and the propagation in the case of have wireless channels. These difficulties appear due to the randomness of the noise and the unpredictability of the channel propagation. Basically, there are two main sources for the system degradation: additive white Gaussian noise (AWGN) and multipath fading.

AWGN is undesirable signals that combined with the sent information making it so difficult for the receiver to extract the correct information. In that kind of noise, the data transmission rate will be affected negatively. There are different sources to have this kind of noise, which can be classified into two main categories: natural and industrial sources. Naturally, the sunray the atmospheric particles could cause AWGN and degrade the system performance. On the other hand, the overhead power lines, electrical and electronic devices and switches are example of industrial noise sources.

Assume we have a white Gaussian noise denoted by $w(t)$ which disturb the information signal $s(t)$, in that case we will have a received signal as follow:

$$r(t) = s(t) + w(t) \quad (8)$$

In radio signal, when the signals get to the antenna of the receiver from different paths it can be called multipath fading. The multipath fading could be caused by different reasons and might be formed in many ways. Ideally, the signals propagate directly to the receiver in one path if there are no obstacles. But in reality, the natural huge objects like mountains could cause a shadowing or scattering for the signal due to its rough surface. The signals also could be reflected or diffracted because of buildings, trees or mountainsides [6].

5. Peak-to-Average Power Ratio (PAPR)

The way of calculation the PAPR depend on the ratio between the maximum power of the complex pass-band signal and the mean power of it. The following equation shows how to calculate the PAPR [7].

$$PAPR = \frac{\max(x^2(t))}{\text{mean}(x^2(t))} \quad (9)$$

Where the amplitude of the complex pass-band signal is denoted by $x(t)$. In the worst-case scenario by adding all the subcarriers, the OFDM peak power for N subcarriers equals to N . In M-QAM and M-PSK, we have noticed that the PAPR increases when the value of M goes up. When we have N goes to ∞ , the maximum PAPR for the signal x_k represented as follow:

$$PAPR_m = \frac{N}{N/N} = N \quad (10)$$

6. Simulation Results

Before going through the results of the BER performance, let us explain the definition of the BER. The bit error is the received bits coming through a communication channel and carried by a stream of data where these bets have been affected and changed by the nature of the communication channel. To calculate the bet error rate, the total number of the affected bits is divided by the entire amount of the transmitted bits during a specific time interval to get a unit-less quantity that is proposed as a percentage.

In the first part of the simulation results, AWGN channel is used as communication channel without including any fading effects. The BER performance for the single-carrier transmission is simulated by generating a MATLAB code for M-PSK modulation type where M is equal to 2, 4, 8 and 16. Then, the same thing is done for multi-carrier transmission scheme (OFDM). After that, a comparison between the OFDM and the SC transmission techniques is presented in terms of BER performance and PAPR behavior using BPSK.

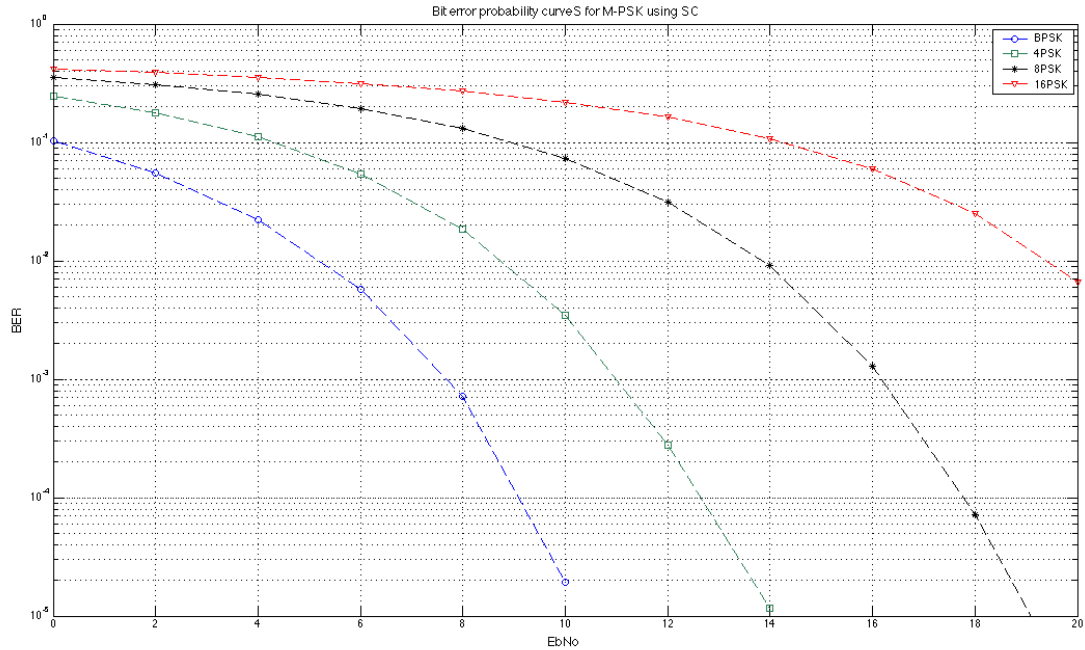

Figure 4: BER curves for SC using M-PSK.

The BER performance is affected by the order of the modulation technique; the lower the order the best the performance. Figure 4 shows BER curves of single-carrier transmission using M-PSK with M= 2, 4, 8, and 16. The curves illustrates that the best BER performance occurs when BPSK is used. The same thing is noticed when the OFDM scheme is used as shown in Figure 5. The 16-PSK modulation technique has the worst BER performance compared to the lower order.

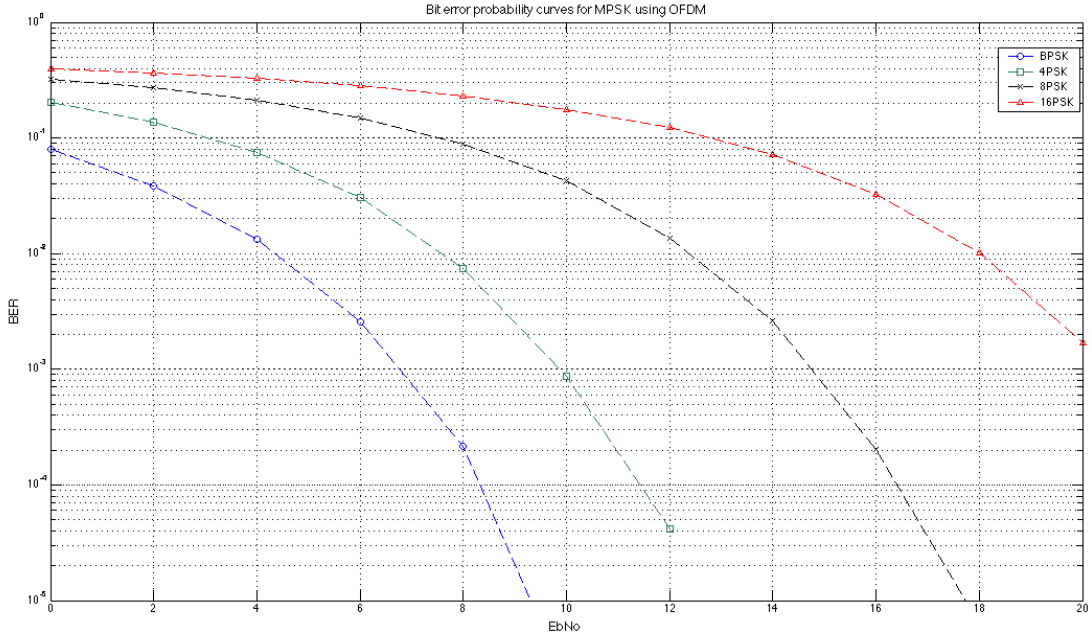

Figure 5: BER curves for OFDM using M-PSK.

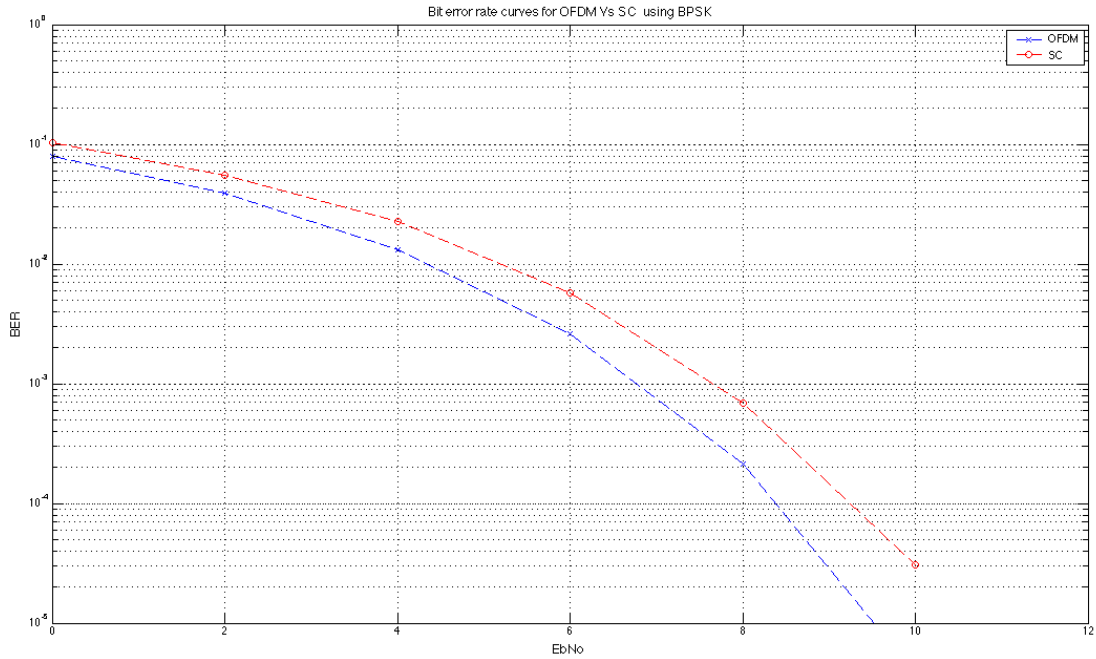

Figure 6: BER curves for OFDM Vs. SC using BPSK.

Figure 6 shows a comparison between OFDM and SC in terms of BER performance using BPSK and from the curves we can see that the use of OFDM reduces the BER percentage. From the SC curve we can indicate higher BER but on the other hand the PAPR distribution is much lower as shown in Figure 7. The red curve in Figure 7 represents the PAPR distribution for OFDM which much higher than the blue one which is for SC. The bad PAPR performance is a major drawback that it appears with OFDM.

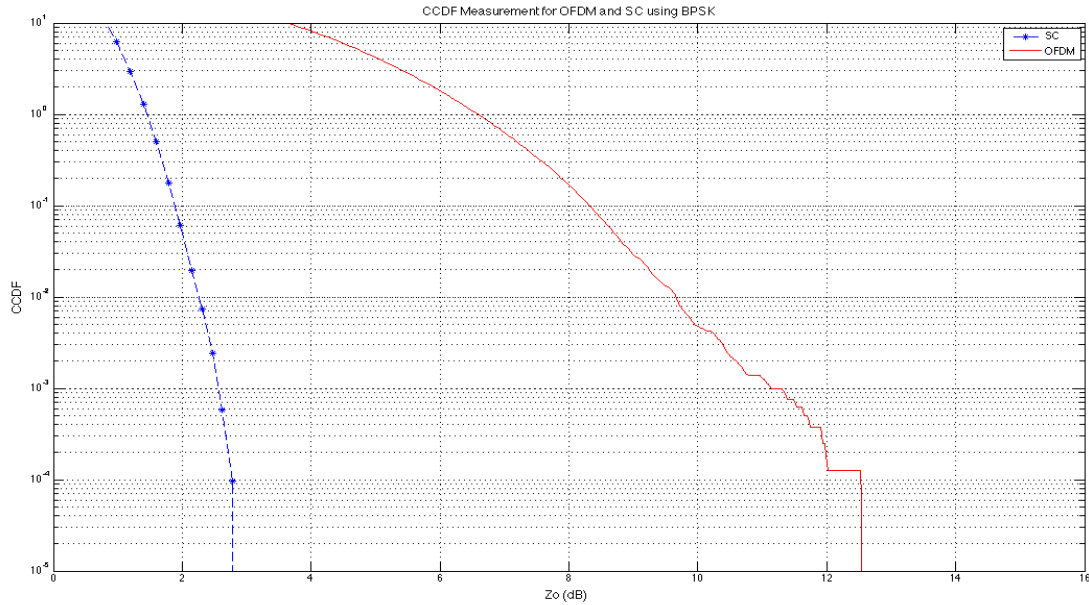

Figure 7: CCDFs of OFDM Vs. SC using BPSK.

7. Conclusion

In this paper, a comparison between multi-carrier and single-carrier systems is presented to study the BER performance. The transmitted data, in both cases, has the same parameters and the signal went through the same channel (AWGN) to make a reasonable comparison. The results showed for both techniques advantages and drawbacks.

From the results, we have noticed that the use of the OFDM transmission system improves the BER performance and outperforms the single-carrier scheme. On the other hand, the OFDM scheme has a main drawback which is the high PAPR compared to the single-carrier. This problem can be dealt with using PAPR reduction techniques, which can be used to improve the performance of PAPR [8] [9].

References

- [1] Principle, H. E., Transmitting, O. F., & By, D. (1990). Multicarrier Modulation for Data Transmission : An Idea Whose Time Has Come. IEEE Communications Magazine, (May).
- [2] "Air Interface for Fixed Broadband Wireless Access Systems", IEEE Standard 802.16-2004, 2004.
- [3] J. Tubbax, et. al, " OFDM versus Single Carrier: A Realistic Multi- Antenna Comparison", EURASIP Journal on Applied Signal Processing 2004:9, 1275–1287_c 2004.
- [4] R. van Nee and R. Prasad, "OFDM for wireless multimedia communications," *Boston, MA: Artech House*, 2000.
- [5] A. Bahai, B. Saltzberg and M. Ergen, Multi carrier digital communications: Theory and applications of OFDM, Springer Science, New York, 2004.
- [6] SALEH, A., VALENZUELA, R., "A Statistical Model for Indoor Multipath Propagation", IEEE Journal on selected Areas in Communications, Volume 5, Issue 2, Feb 1987 Page(s):128 137
- [7] H. Ochiai and H. Imai, On the Distribution of the Peak to Average Power Ratio in OFDM Signals, IEEE Trans. Commun., vol. 49, no. 2, pp. 28289, Feb. 2001.
- [8] S. H. Han and J. H. Lee, "An overview of peak-to-average power ratio reduction techniques for multicarrier transmission," IEEE Wireless Communications, vol. 12,
- [9] Alhasson B. and Matin M. A., "Reduction of PAPR for OFDM Downlink and IFDMA Uplink Wireless Transmissions", International Journal of Computer Science and Information Security, Vol. 9, No. 3, pp 6-13, 2011, ISSN: 1947-5500.

Study of Bit Error Rate (BER) for Multicarrier OFDM

Ahmed Alshammari, Saleh Albdran, and Mohammad Matin

Department of Electrical and Computer Engineering
School of Engineering and Computer Science
University of Denver

Abstract

Orthogonal Frequency Division Multiplexing (OFDM) is a multicarrier technique that is being used more and more in recent wideband digital communications. It is known for its ability to handle severe channel conditions, the efficiency of spectral usage and the high data rate. Therefore, It has been used in many wired and wireless communication systems such as DSL, wireless networks and 4G mobile communications. Data streams are modulated and sent over multiple subcarriers using either M-QAM or M-PSK. OFDM has lower inter symbol interference (ISI) levels because of the low data rates of carriers resulting in long symbol periods. In this paper, BER performance of OFDM with respect to signal to noise ratio (SNR) is evaluated. BPSK Modulation is used in a Simulation based system in order to get the BER over different wireless channels. These channels include additive white Gaussian Noise (AWGN) and fading channels that are based on Doppler spread and Delay spread. Plots of the results are compared with each other after varying some of the key parameters of the system such as the IFFT, number of carriers, SNR. The results of the simulation give visualization of what kind of BER to expect when the signal goes through those channels.

Key Words: OFDM, BER, BPSK, SNR, ISI

1. INTRODUCTION

Nowadays data transmission at high bit rates is a very important feature for many communication systems. The importance of this feature came from the development of communication systems and the need for services like streaming video and digital audio. As a result, high bandwidth and low bit error ratio are two of the most important criteria for modern communication systems. High Speed data, voice signals, multimedia and video are all examples of the services offered by the latest generation of mobile communication systems. The Fourth Generation (4G) is one of the most capable schemes that can provide such services. 4G mainly utilizes the principle of OFDM. These principles have been there since the 1960's [1][2]. Due to the lack of technology, it was not used for high-speed communication systems until the last decade. For example, very powerful processors were needed to carry on FFT and IFFT necessary for OFDM to work but such processors were not around for a long time when the principles of OFDM were in Theory. Also, linear power amplifiers and oscillators with enough stability to maintain subcarriers orthogonally were needed. By the 90's many of these obstacles were solved and since then OFDM has been getting more popular every year because of the many advantages it provides that solve conventional communication issues.

OFDM could be thought of as a particular case of FDM [2]. To understand that difference between FDM and OFDM, we could think of FDM and OFDM as the water coming from the faucet and the shower respectively. Therefore, the issue of ISI and fading effects on the signal are minimized as a result of transmitting the signal in parallel subcarriers with low data rate.

2. OFDM PARAMETERS

The communication channel bandwidth w is divided equally between the subcarriers. The width of each of one of the N subcarriers is $\Delta f = \frac{w}{N}$. The most essential factor in dividing the bandwidth is to achieve orthogonally between subcarriers. This can only be satisfied if the integral of multiplication of two subcarriers is zero for a particular time period. As shown by equation (1) It important to notice that any two sinusoids are orthogonal as long as their frequencies are integer multiples.

$$\int_0^T \cos(2\pi nft) \cos(2\pi mft) dt = 0 \quad (n \neq m) \quad (1)$$

Where n and m indicate the two integers, T is the period of the integration [10]. Also, the multicarrier signal is given as in equation (2)

$$s(t) = \sum_{m=-\infty}^{\infty} \left(\sum_{k=0}^{N-1} x_{k,m} \psi_k(t - mT_c) \right) \quad (2)$$

In the equation above the k^{th} subcarrier is modulated by the $x_{k,m}$ symbol.

The number subcarrier in any OFDM system is decided by two criteria. These two criteria are the size of IFFT and the channel bandwidth. IFFT size is decided fixed by the relation in equation (3). Increasing the number of subcarriers will result in decreasing ISI.

$$(number\ of\ subcarriers \leq \frac{IFFTsize}{2} - 2) \quad (3)$$

Subcarriers with a frequency of $f_k = k/T_{sym}$ are modulated by the symbol $X[k]$ for $N=6$ i.e. $k = 0,1,2 \dots 5$. Demodulation is carried out at the receiver utilizing the principle of orthogonality. N symbols in parallel compose the OFDM Symbol and it is important to know that the original length of the symbol $X[k]$ is extended from T_s to $T_s = NT_s$. This is due to transmitting N symbols simultaneously each of which modulates one of the orthogonal subcarriers.

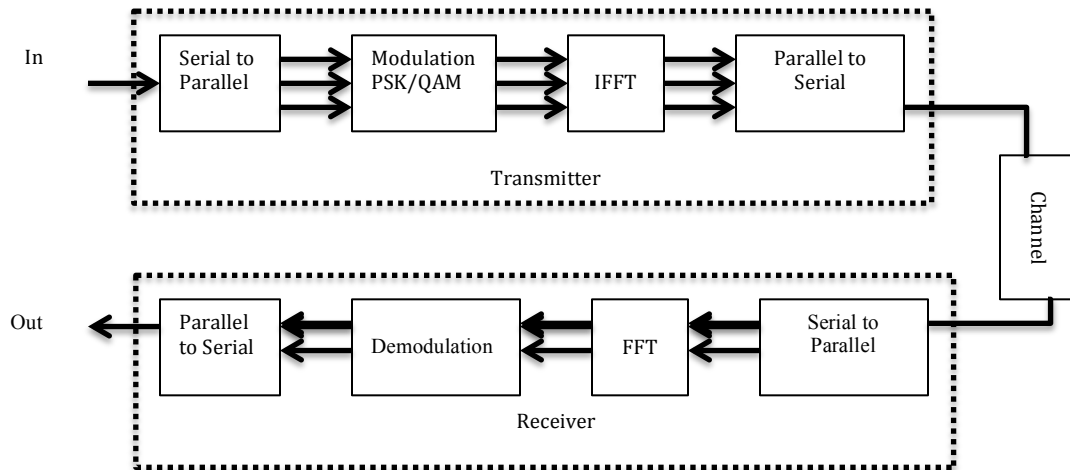

Figure 1 Block diagram of the OFDM system

3. OFDM SYSTEM MODEL

The OFDM system used in this paper is shown in figure 1. Reshaping data streams from series to parallel results in the blocks of data symbols to be transmitted. Assuming that N is the number of these blocks then OFDM symbols are characterized by $X_m = (x_{0,m} \ x_{1,m} \ \dots \ x_{N-1,m})^T$. After that each one of the symbols modulates one subcarrier. A guard band of length N_{cp} is attached to each OFDM symbol. The m^{th} OFDM symbol is given by equation (4).

$$S_m(n) = \begin{cases} \frac{1}{N} \sum_{k=0}^{N-1} x_{k,m} e^{\frac{j2\pi k(n-N_{cp})}{N}} & \text{for } n \in [0, N + N_{cp} - 1] \\ 0 & \text{otherwise} \end{cases} \quad (4)$$

Envelope detector detects the beginning and the end of each frame. Every frame is demodulated to data. Equation (5) represents the received signal $r(n)$ [6]. It is clear that the received signal is nothing but the summations of the white Gaussian noise (AWGN) $n(n)$ and the convolution of the channel's impulse response $h(n)$.

$$r(n) = \sum_{\eta}^{n_{cp}-1} h(\eta) s(n - \eta) + n(n) \quad (5)$$

4. COMMUNICATION CHANNEL

Communication channel means the path that the signal takes between the transmitter and the receiver. There are many forms of that according to the type of communication system. Additive noise and attenuated version of the signal are used to represent the channel in wireless communication systems. The loss in the signal as it approaches the receiving side is manifested by random attenuation while noise is there to represent other interference.

4.1 Fading

In wireless communication, signal might take two or more paths to get to the receiver. This phenomenon is called multipath propagation, which is usually caused, by atmospheric ducting, ionosphere reflection and refraction. Multipath propagation effects on the signal include phase shifting, constructive and destructive interference [5].

Overlapping that result from receiving copies of the transmitted signal at various times is the simplest definition of fading. Therefore, the received signal could have different amplitude and phase because of the propagation time and the intensity distribution of the waves [9].

4.2 Small Scale Fading

Nature of the sent signal and the channel are controls the kind of fading. Symbol duration, Bandwidth and channel parameter are all things that decide the quality of the channel. Doppler spread, RMS and delay spread usually cause four types of fading:

4.2.1 Fading Due To Delay Spread

Delay spread consists of two types [9]

- 1) Flat fading: Flat fading is the most popular kinds of fading. When the signal bandwidth is smaller than the bandwidth of the channel, Flat fading happens. The strength of the signal gets affected by this fading due to the gain variation of the channel while the spectrum remains the same.

- 2) Frequency Selective Fading: Linear phase response and constant gain are the main characteristics of frequency selective fading. The bandwidth of the channel is smaller than that of the signal. Signal is distorted by frequency selective fading due to the multiple version of the signal with various amplitudes and delay. In other word, frequency selective fading in mobile communication occurs as a result of the time dispersion of the transmitted signal.

4.2.2 Fading From Doppler Spread

Slow and fast fading results from Doppler spread. The fading is either slow or fast depending on the speed of the receiver.

- 1) Slow Fading: Symbol period is greater than coherence time in this case. Also, signal changes slower than the channel, which means that variations of the signal are faster than the channel's impulse response
- 2) Fast Fading: Impulse response of the channel variations are very fast through the symbol period i.e. symbol duration of the transmitted signal is greater than the coherence time of the channel

4.4 Communication Channel Model

Filtering properties of the channel is modeled by means of its time varying impulse response. Movement of the mobile is variable that influence time change. Received signal $y(d, t)$ is given by equation (6).

$$y(d, t) = \int_{-\infty}^t x(\tau)h(d, t - \tau)d(\tau) \quad (6)$$

Where $h(d, t)$ is the impulse response of the channel and $x(t)$ is the signal.

Knowing that the position of the receiver is $d = vt$ and knowing that v is just a constant, we could replace d in equation (6) with vt as in equation (7). As a result, mobile radio channels could be expressed as a linear time varying.

$$y(vt, t) = \int_{-\infty}^t x(\tau)h(vt, t - \tau)d(\tau) \quad (7)$$

$$h_b(t, \tau) = \sum_{i=0}^{N-1} a_i(t, \tau)e^{j(2\pi f_c \tau_i(t) + \varphi_i(t, \tau))} \delta(\tau - \tau_i(t)) \quad (8)$$

Impulse response of the baseband channel is given by equation (8). Here, $a_i(t, \tau)$ are the amplitudes and $\tau_i(t)$ are the delays whereas $\theta_i(t, \tau) = 2\pi f_c \tau_i(t) + \varphi_i(t, \tau)$ represent phase shift in the i th component.

In case of time invariant channel, delay occurs in each multipath component of the channel. Impulse response is calculated by equation (9).

$$h_b(\tau) = \sum_{i=0}^{N-1} a_i(t, \tau)e^{j\theta_i(t, \tau)} \delta(\tau - \tau_i(t)) \quad (9)$$

4.5 Rayleigh Distribution

Rayleigh fading is used to statistically model the properties of a channel that experience multipath conditions. According to Rayleigh model, the changes to the power signal are unpredictable and it assumes that there is no direct path between transmitter and receiver. Therefore, it assumes more than one connection that signal travel through to the receiver. Power Density function PDF of Rayleigh distribution is shown in equation (10). It is the result of summation of the quadrature Gaussian noise and the in-phase noise. Therefore, the fading follows Rayleigh distribution pattern.

$$p(r) = \begin{cases} \frac{r}{\sigma^2} e^{-\frac{r^2}{2\sigma^2}} & 0 \leq r < \infty \\ 0 & r < 0 \end{cases} \quad (10)$$

4.5.1 Clarke's Model

Clarke's Model is one of a number of models that generates Rayleigh fading. It depends on the scattering principle to find statistical properties of the channel. Also, it assumes that the transmitter is fixed and has a vertical polarized antenna. N azimuthally plane waves of the antenna with random carrier phases and angles of arrival are assumed while amplitude remains unchanged. Receiver mobility is assumed for flat fading and m_{th} wave that has arriving angle α_m with respect to the x-axis. The Doppler shift is given by equation (11).

$$f_m = \frac{v}{\lambda} \cos \alpha_m \quad (11)$$

Where, λ is the wavelength of incident wave.

The spectrum is limited by $\pm f_m$ with a center frequency that is equal to the carrier frequency f_c . Every received wave in this case has a different carrier frequency with a small shift from the center frequency. The power spectral density of the output is given by equation 3.14. It is clear from that equation that the PDF is zero when $|f - f_c| > f_m$.

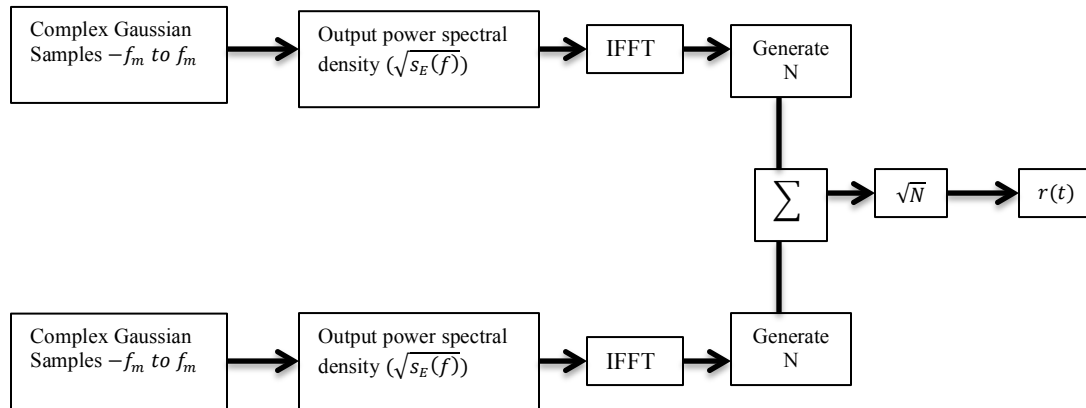

Figure 3 Rayleigh fading implementation

Spectrum is bounded by $\pm f_m$ and f_c the carrier frequency is the center frequency. Carrier frequencies are different for every wave. Equation (12) is the PDF of the received signal is $S(f)$ in equation (12)

$$S(f) = \frac{A[q(\alpha)G(\alpha)+(-\alpha)G(-\alpha)]}{f_m \sqrt{1-\left(\frac{f-f_c}{f_m}\right)^2}} \quad (12)$$

Assuming a vertical $\frac{\lambda}{4}$ antenna, $G(\alpha) = 1.5$ and $p(\alpha) = \frac{1}{2\pi}$ over 0 to 180° , then $S(f)$ becomes as in equation (13).

$$S(f) = \frac{1.5}{\pi f_m \sqrt{1-\left(\frac{f-f_c}{f_m}\right)^2}} \quad (13)$$

PDF of Doppler components arriving between 0 and π are infinite. However, the probability that one component reaches the receiver within these angles is zero because α is uniformly distributed.

Frequency Domain Rayleigh Fading is simulated according to the block diagram in figure 3. The signal goes through In-phase & quadrature modulation first. Therefore, Two independent Gaussian low pass noise sources are used to generate In-phase and quadrature fading components. IFFT is implemented as the last step in the simulator to shape the random signal

5. RESULTS

As discussed in the previous sections, OFDM technique as applied to a wireless communication in order to examine its performance. The signal is transmitted in MATLAB program over AWGN and fading Channels with various SNRs. The OFDM system is simulated according to the Model illustrated in the first section of this paper. Clarke's model has been utilized to implant the system over fading channels. Mobility of the receiver is one specification for this model. It was assumed the mobile is either moving slowly with a speed of 3 miles/hour or fast with a speed of 100 miles/hour in order to implement flat fading and frequency selective fading. Clarke's model assumes that there is no line of sight between the mobile and the transmitter because it depends on the principle of Rayleigh distributions. Figure 4 Shows the BER over AWGN channel with BPSK as the modulation technique. At the same values of SNR, AWGN has shown the best BER performance after that come both of flat fading channels as in figures 5&6 and frequency selective fading in figures 7&8 respectively. It is also noticed that increasing the speed of the receiver negatively affects the quality of the received signal.

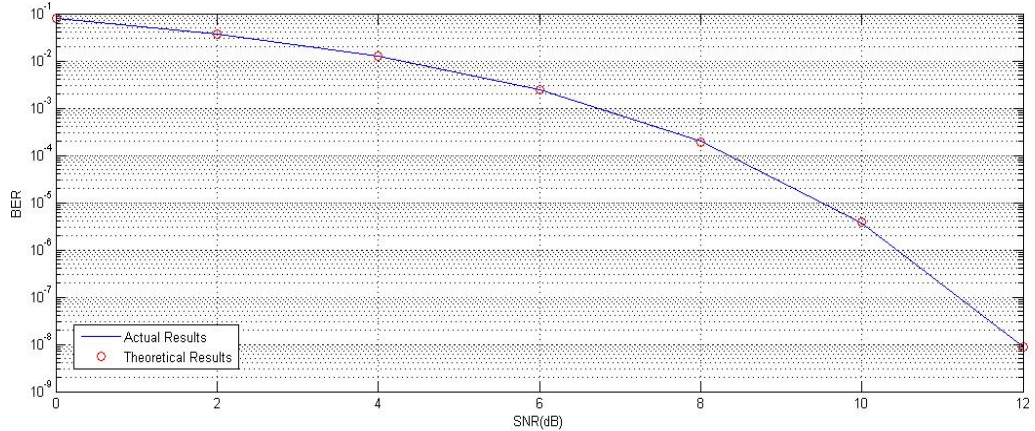
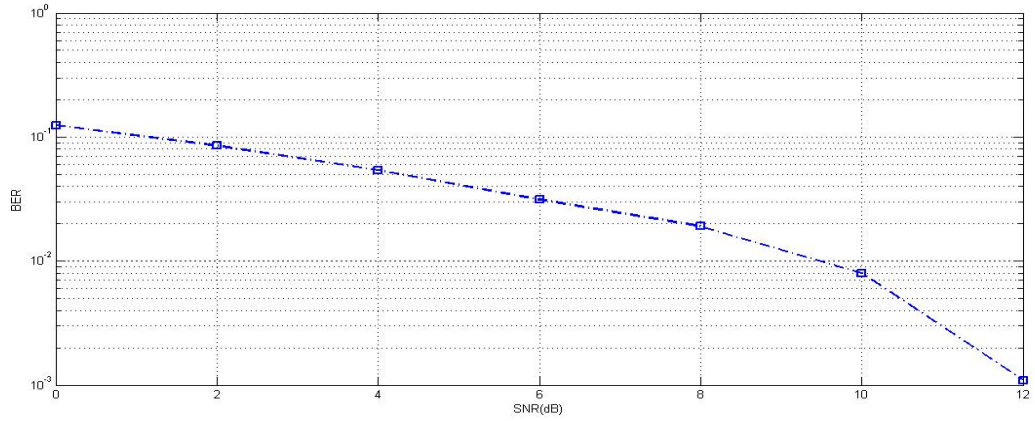
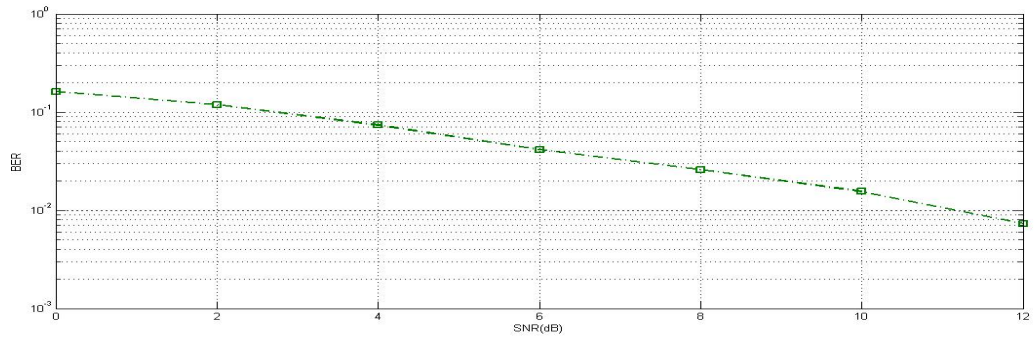

Figure 4 Shows the BER over AWGN

3 Miles/hour was assigned as the speed of the receiver for the purpose of simulating Small Doppler Spread and 100 Miles/hour was used to simulate large Doppler Spread. Figures 5 and 6 shows BER over Flat slow Fading and Flat Fast Fading respectively.



Figures 5 BER over Flat Slow Fading



Figures 6 BER over Flat Fast Fading

In the Case of Frequency selective fading, Multiple Clarke's model is used. Different Delayed versions of the received signal are subjected to Clark's model to simulate frequency selective Fading. 4 different paths are assumed with delay of 0,4,8 and 16 samples. 3 Mile/hour mobile speed is used to simulate Frequency Selective Slow Fading and 100 Mile/hour speed is used to simulate Frequency Selective Fast Fading. Figures 7 and 8 shows BER over Frequency Selective Slow Fading and Frequency Selective Fast Fading respectively.

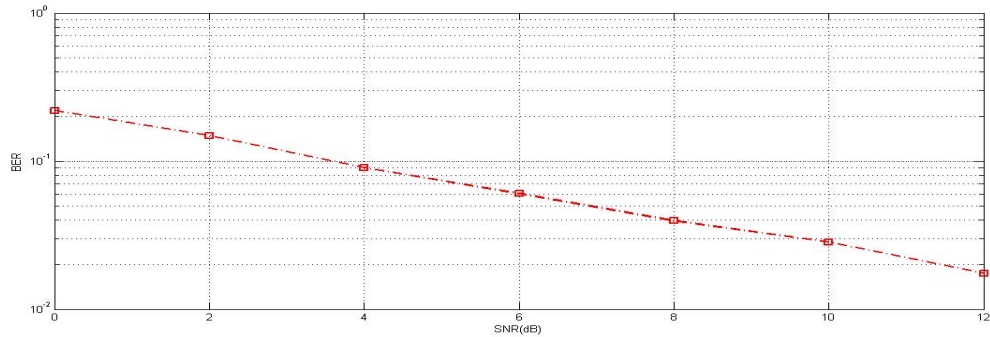

Figures 7 BER over Frequency Selective Slow Fading

BER of the four kinds of Fading are shown in figure 9. It is clear that the quality of the signal received from frequency selective fading channel is less than the one received from Flat Fading. Also, the quality of the received signal is less when the mobile is moving with higher speeds.

6. CONCLUSION

Effects of different wireless channels have been investigated in this paper. Results shows that AWGN Channel has the best performance while the results of flat fading and frequency selective fading indicates that they are of less efficient respectively. BPSK was used as the modulation technique for the purpose of studying the performance of OFDM. Also, Clarke's model was implemented to simulate the multipath channel environment. Fading Channels are very common in wireless communications. Therefore, Transmitting signals over fading channels cause a lot of problems to the process. Results show that the quality of the received signal is less when the mobile is moving with higher speed.

This research could be extended study to aspects of OFDM. For example, QAM could be used instead of MPSK modulation and compare outputs of both modulation techniques together. Also, it is possible to extend this research to the Multiple Input Multiple Output OFDM (MIMO-OFDM) Channels. MIMO is especially used for the purpose of wideband transmission after its combination with OFDM.

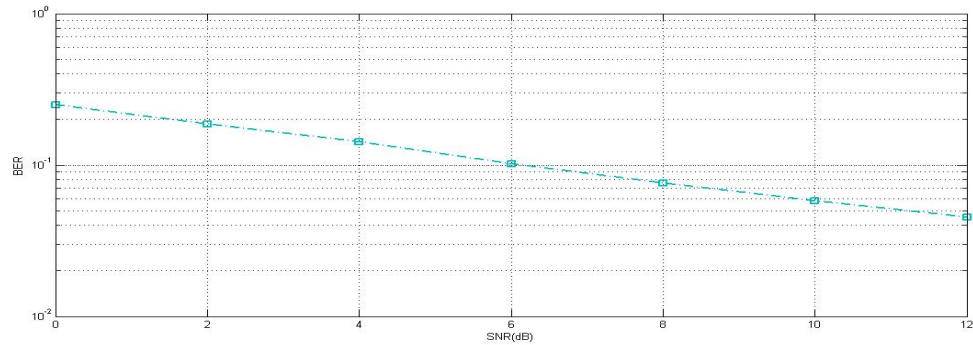

Figures 8 BER over Frequency Selective Fast Fading

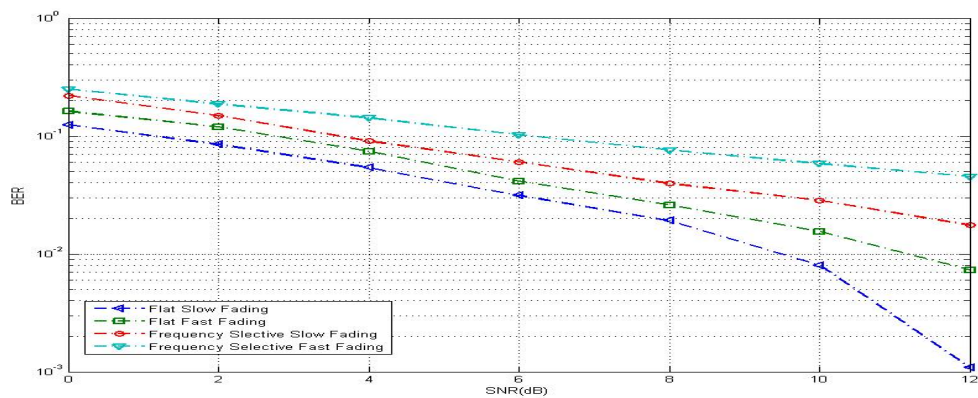

Figure 9 Comparing BER of The Different Channels

REFERENCES

- [1] BBC Research Department, E. D. "An Introduction to Digital Modulation And OFDM Techniques". (1993).
- [2] Cho, Y., Kim, J., Yang, W., & Kang, C. [MIMO-OFDM wireless communication with MATLAB. Singapore: Wiley]. (2010).
- [3] R. Frederiksen, F.B & Prasad, "An overview of OFDM and related techniques towards development of future wireless multimedia communications," in *IEEE*, 2002.
- [4] J. C. Chuang, "The Effects of Time Delay Spread on Portable Radio Communications Channels with Digital Modulation," *IEEE journal on selected areas in communications*, no. 5, 1987.
- [5] Communication, W., Spring, T., Mathur, S., & Engineering, E. Small Scale Fading in Radio Propagation. (2005).
- [6] Engels, M. [Wireless OFDM systems 2]. (2nd Ed.). Boston: KLUWE Academic. (2002).
- [7] Gayatri, S., Prabhu, P., & Shankar, M. (n.d.). "Simulation of Flat Fading Using MATLAB for Classroom Instruction". IEEE TRANSACTIONS ON EDUCATION.
- [8] Jeyasri, V. "Mobile Communications". India: Technical Publications Pune. (2009).
- [9] Rappaport, T. "Wireless Communication". Upper Saddle River, NJ: Prentice Hall. (1996).
- [10] SANKAR, K. Understanding an OFDM transmission. (2008). Retrieved April 15, 2012, from <http://www.dsplog.com/2008/02/03/understanding-an-ofdm-transmission>
- [11] Bloul A., Mohseni S., Alhasan B., Ayad M., and Matin M. A. "Simulation of OFDM technique for wireless communication systems", Proc. SPIE, Vol. 7797, 77971B, (2010), DOI:10.1117/12.863