

2001

# Tanker accidents : double hull is not the only viable alternative

Mukkadayil Paily John  
*World Maritime University*

Follow this and additional works at: [http://commons.wmu.se/all\\_dissertations](http://commons.wmu.se/all_dissertations)



Part of the [Environmental Studies Commons](#)

---

## Recommended Citation

John, Mukkadayil Paily, "Tanker accidents : double hull is not the only viable alternative" (2001). *World Maritime University Dissertations*. 257.  
[http://commons.wmu.se/all\\_dissertations/257](http://commons.wmu.se/all_dissertations/257)

This Dissertation is brought to you courtesy of Maritime Commons. Open Access items may be downloaded for non-commercial, fair use academic purposes. No items may be hosted on another server or web site without express written permission from the World Maritime University. For more information, please contact [library@wmu.se](mailto:library@wmu.se).

**WORLD MARITIME UNIVERSITY**  
Malmö, Sweden

**TANKER ACCIDENTS: DOUBL HULL IS NOT  
THE ONLY VIABLE ALTERNATIVE**

By

**MUKKADAYIL PAILY JOHN**  
India

A dissertation submitted to the World Maritime University in partial  
fulfilment of the requirements for the award of the degree of

**MASTER OF SCIENCE**

In

**MARITIME AFFAIRS**  
**(Maritime Safety and Environmental Protection)**

2001

## Declaration

I certify that all the material in this dissertation that is not my own work has been identified, and that no material is included for which a degree has previously been conferred on me.

The contents of this dissertation reflect my own personal views, and are not necessarily endorsed by the University.

(Signature) .....

(Date) .....

Supervised by:

Professor Jan-Åke Jönsson  
World Maritime University

Assessor:

Professor Rajendra Prasad  
World Maritime University

Co-assessor:

Captain Kjell Grahm  
Visiting professor  
World Maritime University

**Dedicated to  
my mother who passed away on  
15<sup>th</sup> January 2000**

## **Acknowledgements**

This dissertation was developed as part of my post-graduate studies at the World Maritime University. These studies would not have been possible without the kind support of a number of people and organisations, to which I am deeply indebted.

First of all, I am grateful to the Almighty God, for giving me an opportunity and courage to pursue the course and complete the studies at the World Maritime University. My sincere thanks to Mr. D.T. Joseph, Director General of Shipping, India, Mr. B.K. Biswas, Chief Surveyor with the Government of India, and Mr. Subimal Chakroborthy, Principal Officer, Mercantile Marine Department, Chennai, India, who encouraged and sponsored me for attending the course at the World Maritime University.

I wish to express my gratitude and sincere thanks to the Swedish International Development Cooperation Agency for the fellowship provided to facilitate my studies. My sincere thanks are extended to my dissertation supervisor, Professor Jan-Åke Jönsson and Dr. P.K. Mukherjee, Faculty Professor for their guidance and advice in overcoming the difficulties encountered during the preparation of this dissertation. My special thanks go to Ms Susan Wangeci-Eklöw and Ms Cecillia Denne of WMU Library for their sincere support.

My heart felt and profound appreciation and thanks are extended to my dear wife, Dr. Shirley John, son Joshin John and daughter Litty John who sacrificed and volunteered to live with my absence, without their active and unstinting support and encouragement I could not have mustered strength and courage to attend this post-graduate course at World Maritime University, Malmö.

## **Abstract**

Title of Dissertation: **Tanker accidents: Double Hull is not the only viable alternative**

Degree: **MSc**

This dissertation is a study of the international maritime regime relating to the mitigation of pollution from oil tankers in the event of collision or stranding. The study focuses on issues that have evolved as a result of various amendments to relevant Conventions adopted in the recent years.

A brief review of the development of maritime regulations for prevention of pollution of sea from ships is undertaken. The backgrounds to the enactment of the US OPA 90 and the adoption of regulations I/13G and I/13F to MARPOL 73/78 are discussed, and the phase out programmes of existing single hull tankers in both cases are examined.

Regulatory features of the double hull tanker are discussed, and the potential design, construction, operation problems and the risks involved are analysed. Alternative double hull designs to overcome some of the problems and risks have been discussed.

Accidental outflow of oil from tankers can be reduced by the use of double hull, reduced tank size, and the use of outflow prevention measures inside a tank. Whether the Mid-deck and Coulombi Egg concepts are superior to the double hull solution to limit the total amount of oil spilled, are examined.

The concluding chapter evaluates the findings of the research on double hull tanker and alternative design concepts, and makes certain recommendations and suggestions aimed at relevant authorities.

**KEYWORDS:** Alternative, Amendment, Disaster, Pollution, Prevention, Regulation.

# TABLE OF CONTENTS

Declaration		ii
Acknowledgements		iv
Abstract		v
Table of Contents		vi
List of Figures		ix
List of Abbreviations		xii
<b>1</b>	<b>Introduction</b>	
1	Objective of the research	1
2	Research methodology	2
<b>2</b>	<b>Tanker accidents: its influence in developing international regulations</b>	
1	Introduction	3
2	Marine pollution	4
3	MARPOL 73/78	6
4	The Exxon Valdez disaster	10
5	The Oil Pollution Act 1990 (OPA 90)	12
	5.1 Emergency response plans	13
	5.2 Double hull tank vessels & single hull phase out	13
	5.3 Liability	13
	5.4 OSLT fund	13
	5.5 Navigational measures & state pre-emption	14
6	MARPOL regulations 13G & 13F	14
<b>3</b>	<b>The Erika disaster and its aftermath</b>	
1	Introduction	20
2	The Erika disaster	20
3	Fact or fiction	23
	3.1 Shipowners	24
	3.2 Classification societies	24
	3.3 Flag States	25
	3.4 Port States	26
	3.5 Charterers	27
4	Aftermath in Europe	27

4.1	The French action	27
4.2	The European Commission directives	28
4.2.1	Erika I-package	28
4.2.2	Erika II-package	29
5	Single hull phase out - revised timetable	30
5.1	Three categories of tankers	30
5.2	Exemptions	31
5.3	Condition Assessment Scheme (CAS)	31
6	Other post-Erika amendments	31
<b>4</b>	<b>Design characteristics of double hull tankers</b>	
1	Introduction	33
2	Regulatory features	33
3	Design & construction problems	35
4	Alternative double hull designs	38
4.1	Alternatives A1 and A2	39
4.2	Alternatives B1 and B2	40
4.3	Alternatives C1 and C2	42
4.4	Alternatives D1 and D2	42
4.5	Alternatives E1 and E2	43
<b>5</b>	<b>Double hull tanker concerns</b>	
1	Introduction	46
2	Potential operational problems	47
2.1	Problems relating to ballast space	47
2.2	Free surface effect & angle of loll	48
2.3	Sloshing	51
3	Corrosion risks	51
3.1	Pitting	52
3.2	Bacterial corrosion	53
3.3	Coating	55
4	Fatigue risks	56
4.1	Environmental loads & corrosion	59
4.2	Steel types	59
4.3	Trade routes	59
4.4	Relative deflection	60
4.5	Hot spot stresses	61
5	Structural failures in double hull tankers	61
<b>6</b>	<b>Alternatives to double hull tanker</b>	
1	Introduction	70



2	Mid-deck tanker design	72
2.1	Principal features	73
2.2	Oil outflow containment	74
2.3	Safety aspects	75
2.4	Collision & grounding	76
3	Coulombi Egg design	78
3.1	Basic features	78
3.2	Transverse web frames & transverse bulkheads	79
3.3	Fabrication	81
3.4	Grounding & collision	82
3.5	Cracks & fractures	86
3.6	Ballasting & cargo handling	86
3.7	Construction cost	87
3.8	Observations	87
4	COBO proposal	89
4.1	Oil outflow prevention	89
4.2	Salvage & tank cleaning	90
4.3	Building cost	90
5	Other alternative concepts	93
<b>7</b>	<b>Summary, conclusion and recommendations</b>	
1	Summary & conclusion	97
2	Recommendations	99
	<b>References</b>	101

## LIST OF FIGURES

Fig. 1	99.996% of world oil transported safely	4
Fig. 2	Phasing out of single hull tankers	17
Fig. 3	Hydrostatically Balanced Loading	19
Fig. 4	Typical double hull midship section nomenclature	36
Fig. 5	Alternative A1	39
Fig. 6	Alternative A2	39
Fig. 7	Alternative B1	40
Fig. 8	Alternative B2	40
Fig. 9	Alternative C1	41
Fig. 10	Alternative C2	41
Fig. 11	Alternative D1	42
Fig. 12	Alternative D2	42
Fig. 13	Alternative E1	43
Fig. 14	Alternative E2	43
Fig. 15	Diagrammatic section of a single hull tanker and its stability curve	50
Fig. 16	Diagrammatic section of a double hull tanker and its stability curve	50
Fig. 17	Grooving corrosion in a stiffener connection	53
Fig. 18	Typical grooving corrosion in stiffener connection	54
Fig. 19	Severe pitting corrosion in the bottom plate in tank	54
Fig. 20	Bacterial corrosion	56
Fig. 21	Pitting corrosion in ballast tank	57

Fig. 22	Coating is the best solution when pitting occurs	57
Fig. 23	Fractures/ Cracks statistics	58
Fig. 24	Forced deflection	60
Fig. 25	Areas susceptible to stress concentration on midship	62
Fig. 26	Areas susceptible to stress concentration on transverse bulkheads	63
Fig. 27	Bilge hopper: Connection of hopper plate to inner bottom	64
Fig. 28	Wing ballast tank: Connection of longitudinals to transverse webs	65
Fig. 29	Connection of transverse bulkhead	66
Fig. 30	Web frame in cargo tank: Tripping brackets	67
Fig. 31	Connection of longitudinals to horizontal stringers	68
Fig. 32	Vertically corrugated transverse bulkhead stools	69
Fig. 33	General tank layout of a mid-deck tanker	72
Fig. 34	Hull section of a Mitsubishi mid-deck tanker	74
Fig. 35	An emergency suction line below the mid-deck on MHI's design	75
Fig. 36	General layout of a Coulombi Egg Tanker	80
Fig. 37	Midship section of a Coulombi Egg design	80
Fig. 38	Transverse web frame construction of a Coulombi Egg design	81
Fig. 39	A Coulombi Egg tanker proposal for building block fabrication	82
Fig. 40	Midship section showing partial bulkhead	84
Fig. 41	Breach of wing cargo tank forces oil to the ballast tank	85
Fig. 42	Breach of lower center tank forces oil to both wing tanks	85
Fig. 43	Objective of tank size and location	90
Fig. 44	Small outflow after side and bottom damage in the COBO design	91
Fig. 45	The COBO midship section in three dimensions	92
Fig. 46	Small structural loads of COBO in laden conditions	92
Fig. 47	An economical and ecological comparison	93
Fig. 48	MARC GUARDIAN	94
Fig. 49	EPOCH	94

Fig. 50	Intertanko middeck	94
Fig. 51	Under pressure	94
Fig. 52	Imaginary double bottom	94
Fig. 53	SCOL	94
Fig. 54	POLIS	95
Fig. 55	POLMIS(under pressure)	95
Fig. 56	POLMIS ballast bag	95
Fig. 57	DIATANK	95
Fig. 58	HONYCOMB	95
Fig. 59	STROBBS brine system	95

## LIST OF ABBREVIATIONS

ABS	American Bureau of Shipping
AUPS	American under pressure system
BM	Bending moment
BMER	French marine accident investigation bureau
BV	Bureau Veritas
CAS	Condition Assessment Scheme
CLC 1969	International Convention on Civil Liability for Oil Pollution Damage, 1969
COBO design	Combination of basic objectives design
COW	Crude Oil Washing
DB	Double bottom
DNV	Det Norske Veritas
dwt	Deadweight
EC	European Commission
ERS	Emergency rescue system
ERTS	Emergency rapid transfer system
ESP	Enhanced Survey Program
EU	European Union
FUND 1971	International Convention on the Establishment of an International Fund for Compensation for Oil Pollution Damage, 1971
GL	Germanischer Lloyds

GM	Metacentric height
GT	Gross tons
GZ	Righting lever
HBL	Hydrostatically balanced loading
HTS	High tensile steel
ICM	Increased corrosion margin
ICS	International Chamber of Shipping
IDB	Imaginary double bottom
IGS	Inert Gas System
IMCO	Intergovernmental Maritime Consultative Organization
IMO	International Maritime Organization
INTERTANKO	The International Association of Independent Tanker Owners
INTERVENTION 1969	International Convention Relating to Intervention on the High Seas on Cases of Oil Pollution Casualties, 1969
IOPC Fund	The International Oil Pollution Compensation Fund
ITOPF	The International Tanker Owners Pollution Federation
L/D	Length/draught
LR	Lloyd's Register
LSC	Liner Shipping Conference
MARPOL 1973	The International Convention for the Prevention of Pollution from Ships, 1973
MARPOL 73/78	International Convention for the Prevention of Pollution from Ships 1973, as modified by the Protocol of 1978 relating thereto
MEPC	Marine Environmental Protection Committee
MHI	Mitsubishi Heavy Industries
MIC	Microbial induced corrosion
MMA	Malta's Maritime Authority
MOU	Memorandum Of Understanding

NRC	National Research Council
OCIMF	Oil Companies International Marine Forum
OILPOL 1954	The International Convention for the Prevention of Pollution of the Sea by Oil 1954
OPA 90	Oil Pollution Act of 1990
OSLTF	Oil Spill Liability Trust Fund
PL	Protective location
POLIS	Pollution limitation system
PSC	Port State Control
Regulation I/13	Regulation 13 of Annex I
RINA	Registro Italiano Navale
SBT	Segregated ballast tank
SCF	Stress concentration factor
SCOL	System for controlled oil leakage
SOB	Sulphur oxidising bacteria
SOLAS 74	International Convention for the Safety of Life at Sea, 1974
SOPEP	Shipboard Oil Pollution Emergency Plan
SRB	Sulphate reducing bacteria
TSCF	Tanker Structure Co-operative Forum
TSPP	Conference on Tanker Safety and Pollution Prevention
VLCC	Very large crude oil carrier

# CHAPTER 1

## Introduction

In the wake of the *Exxon Valdez* tanker disaster in 1989, which polluted the environmentally sensitive coastal areas of Alaska, the social and political climate in the United States at that time demanded action and the US Congress introduced the Oil Pollution Act 1990 (OPA 90) requiring double hull for new tank vessels and specifying a phasing out schedule for existing single hull tank vessels operating in US waters. Further, the International Maritime Organisation (IMO) adopted amendments to the MARPOL 73/78 to put an end to catastrophic oil spills caused by tanker accidents as a result of the worldwide political pressure. Following the *Erika* disaster and with the mounting concerns, the phasing out schedule of single hull tankers was revised by the IMO in April 2001.

### 1. Objective of the Research

The dissertation focuses mainly to reveal the problems and difficulties faced during design, construction and operation of double hull tankers as compared to other alternatives and also to discuss some of the alternative design concepts with its merits in mitigating oil pollution. It emphasises the need for careful consideration of all aspects by the concerned authorities before taking decisions such as to implement design changes to phase out single hull tankers, which has far reaching dimensions and resulting implications. It also points out the technological freeze created for developing alternatives to double hull design by the tough stand taken by the United States.



## **2. Research Methodology**

In this dissertation the development of international regime for control of marine pollution is examined. The requirements emanated out of the unilateral decision by the United States to implement the OPA 90 and the international regime by the MARPOL 73/78 are critically analysed. Literature research on the subject including conceptual design has been carried out. Information was also collected from the Internet sources. Interviews were held; contacts were established with the people related to the design, construction and operation of various types of tankers and information collected. The effectiveness of the present regulations regarding the design, construction and operation of double hull tankers are addressed with respect to problems faced and some alternative tanker designs are suggested. Opinions of many critics regarding numerous potential operational problems are critically analysed. Advantages and disadvantages of various designs have been examined.

During the course of collecting data for preparation of this dissertation, many experienced surveyors from various maritime administrations and classification societies were interviewed and their expert opinions were obtained. Almost 17 years of the writer's experience as a marine engineer on board ships after graduation in engineering and about 9 years of experience as maritime administration surveyor with the government of India with the active involvement in shipbuilding and ship repair has been of added advantage for analytical assessment of the subject.

## **CHAPTER 2**

# **Tanker Accidents: its Influence in Developing International Regulations**

### **1. Introduction**

Between 1970 and 1984 oil tankers spilled about 3,824,000 tons of oil worldwide. During the next 14-year period, from 1985 to 1998, the quantity of oil spilled was reduced to 1,535,000 tons; a 60% reduction despite an 80% increase in tanker activity ('Strong improvement', 1999, p.5). (See Fig.1). The main causes for tanker accidents that have led to large oil spills include groundings on reefs, collisions with other vessels, and fires and explosions emanating from cargo. Statistics from ITOPF (2001, pp.1-3) show that the number of oil spills per year during the periods 1970-'79, 1980-'89 and 1990-'99 were 24.1, 8.8 and 7.3, respectively, and that the maximum of 34 spills were in the year 1979. Patin (1999, p.2) states that the quantity of oil spilled by tanker accidents in 1989 and 1990 were 114,000 and 45,000 tons, respectively, whereas the average volume of oil pollution caused by marine oil transportation was 500,000 tons per year.

The world's first oil tanker carrying kerosene started operating in the late 19<sup>th</sup> century. However, marine oil pollution from ships was felt to be a problem requiring attention only during World War I (IMO, 2000, p.2). The first International Conference on Oil Pollution Prevention at Sea was convened in the United Kingdom in May 1954, which adopted the International Convention for the Prevention of Pollution of the Sea by Oil, 1954 (OILPOL 1954). It recognized the potential of oil to pollute the marine

environment from shipboard operations. The Convention prohibited discharge of oily wastes within a certain distance from land and in designated ‘special areas’, and required the provision of reception facilities for oil waste from ships in ports and terminals (IMO, 1997a, p.1).

This chapter focuses on the background that led to the adoption and implementation of international conventions for the control of oil pollution from ships. It will also touch on the development of the international regime following some of the major oil spills from tankers, namely, the *Torrey Canyon*, the *Amoco Cadiz* and the *Exxon Valdez*.

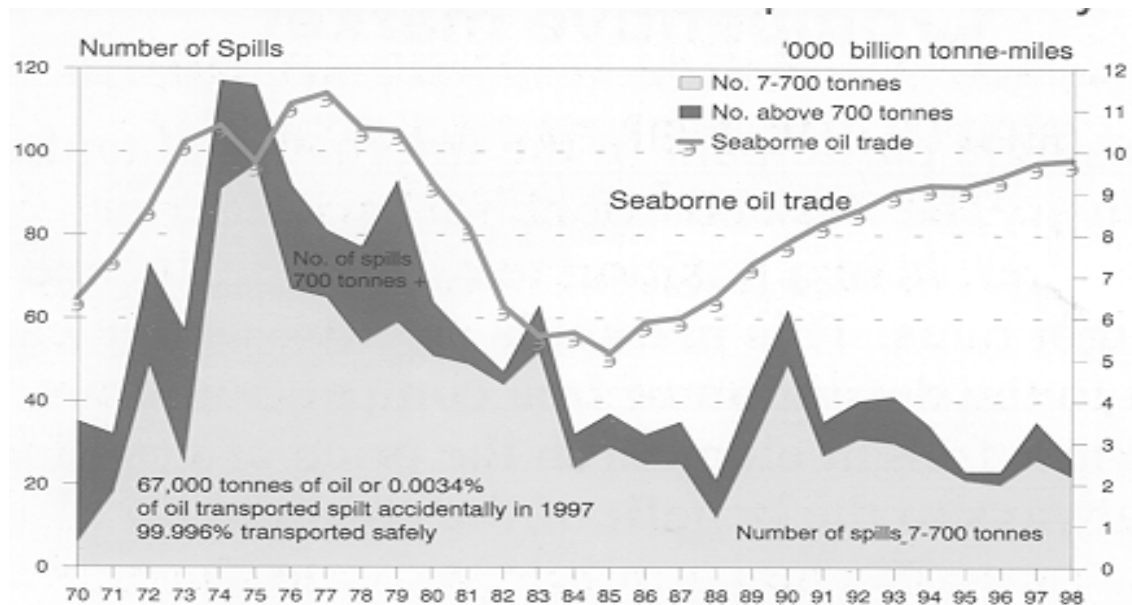

Fig.1. 99.996% of world oil transported safely

(Source: Intertanko Houston Tanker Event, April 1999, p.5)

## 2. Marine Pollution

When the Inter-governmental Maritime Consultative Organization (IMCO)<sup>1</sup> became operational in 1959, marine pollution was regarded as a relatively minor problem.

<sup>1</sup> An International Conference held by United Nations adopted the Convention establishing IMCO on 6 March 1948. The Convention entered into force on 17 March 1958. The name IMCO was changed to the

OILPOL 1954 was amended in 1962 to include ships of lesser gross tonnage and to enlarge the prohibited zones. In 1967, however, the scenario changed when the supertanker *Torrey Canyon* ran aground on Seven Stones Reef while entering the English Channel and spilled<sup>2</sup> 95,000 tons of crude oil. This caused massive oil pollution affecting the French and British shores with major ecological consequences (Patin, 1999, pp. 2-3). It was the biggest marine pollution disaster in history at the time.

The *Torrey Canyon* incident revealed that deficiencies prevailed in the existing system for mitigating oil spills from ships, and providing compensation to victims of pollution damage. Also, there was inadequacy of shipping traffic lanes. It was primarily this incident that led to the adoption of the following International Conventions:

- International Convention for the Prevention of Pollution from Ships, 1973 (MARPOL 1973);
- The International Convention Relating to Intervention on the High Seas in Cases of Oil Pollution Casualties (INTERVENTION), 1969;
- The International Convention on Civil Liabilities for Oil Pollution Damage (CLC), 1969; and
- The International Convention on the Establishment of an International Fund for Compensation for Oil Pollution Damage (FUND), 1971. (IMO, 1998, p.3)

Although tanker accidents caused significant oil spills and environmental pollution, it was recognized that most of the oil entering the sea resulted from routine tanker operations. OILPOL 1954 was further amended in 1969, which entered into force in 1978. The amendment introduced the 'load on top' procedure. After discharging cargo, a tanker needs to take seawater as ballast in some of its tanks to maintain the minimum

---

International Maritime Organization (IMO) by amending the original Convention in 1975, which entered into force in 1982.

<sup>2</sup> IMO document shows the quantity of oil spilled as 120,000 tons, whereas, ITOPIF statistics shows the quantity as 119,000 tons. The quantity shown by Patin (1999) is 95,000 tons.

seagoing draft condition during the ballast voyage. When seawater is taken into some empty cargo tanks it mixes with oil residues in the tank and becomes 'dirty ballast', which is unsuitable for discharging to sea at the loading terminal. The load on top method involves the following procedure (Marton, 1984, pp. 194-195).

1. During the ballast voyage some empty cargo tanks are cleaned at sea and filled with clean ballast water, which can be pumped back to the sea without risk of pollution when the tanker reaches the loading terminal. The oily washings from the tank cleaning are pumped into a designated tank called the 'slop tank'.
2. In the 'dirty ballast' tanks, the oil floats to the top and the clean water under the oil is discharged to the sea and the oily layer on top is transferred to the slop tank.
3. In the slop tank, the dirty washings and the oil from dirty ballast settle into a layer of oil floating on clean seawater. This clean water under the oil is carefully pumped back into sea and the oily waste is left on board. The next cargo is loaded on top of the remaining oil and all of it is discharged when the tanker berths at the discharge terminal.

The load on top procedure has the advantages of reducing operational pollution and saving oil cargo (IMO, 2000, p.3; IMO, 2001b, FAQs)

### **3. MARPOL 73/78**

The enormous growth in the size of oil tankers with the consequent carriage of huge quantities of oil by sea, the development and increase of chemical tankers, and the growing concern for the world's environment during the end of 1970s, made many countries feel that OILPOL 1954 was inadequate despite the various amendments which had been incorporated. As a result, an International Conference on Marine Pollution was convened by IMO in 1973. In this Conference the International Convention for the

Prevention of Pollution from Ships, 1973 (MARPOL 1973) was adopted, covering various ship-generated sources of pollution contained in the five annexes<sup>3</sup> as below:

Annex I Regulations for the prevention of pollution by oil

Annex II Regulations for the control of pollution by noxious liquid substances in bulk

Annex III Regulations for the prevention of pollution by harmful substances carried by sea in packaged form

Annex IV Regulations for the prevention of pollution by sewage from ships

Annex V Regulations for the prevention of pollution by garbage from ships.

Most of OILPOL 1954 together with its amendments are incorporated in Annex I. The Convention requires continuous monitoring of oily water discharges from oil cargo spaces and machinery spaces. State Parties are required to provide reception and treatment facilities for slops and oily water from ships at oil terminals and ports. A number of additional 'special areas' are also established. Regulation 13 of Annex I requires segregated ballast tanks (SBT)<sup>4</sup> on new tankers over 70,000 tons dwt. A proposal by the United States for a requirement for double bottoms was not accepted by the Convention (IMO, 2000, p.4).

A State could become party to the MARPOL 1973 only by ratifying Annexes I and II. Annexes III to V were optional. The Convention required ratification by 15 States with a combined merchant fleet of not less than 50% of the world shipping gross tonnage, to enter into force. The prerequisite to comply with the provisions of Annex II along with Annex I made it difficult for many States to ratify the MARPOL 1973 Convention. This became a major concern. A series of tanker accidents occurred in 1976-1977,

---

<sup>3</sup> The International Conference of Parties to MARPOL 73/78 held at London in September 1997 adopted the Protocol of 1997 to amend MARPOL 73/78, which sets out in its annex the new Annex VI - Regulation for prevention of air pollution from ships.

<sup>4</sup> Segregated ballast tanks are those ballast tanks exclusively used for carrying clean ballast water.

mostly in and around the United States waters. For example, in December 1976 an oil tanker *Argo Merchant* ran aground and broke apart southwest of Nantucket Island, spilling her entire cargo of 7.6 million gallon fuel oil (Fact Monster, 2001). Other major oil spills were 100,000 tons from the *Urquiola* at La Coruna, Spain and 95,000 tons from the *Hawaiian Patriot* 300 nautical miles off Honolulu (ITOPF, 2001, p.4)

The increasing awareness of the disastrous effects of oil pollution on the coastal ecology, coupled with dramatic media coverage, led to an enormous public outcry in the United States. With mounting pressure from maritime states affected by the oil pollution and at the initiative of the United States, IMO convened the Conference on Tanker Safety and Pollution Prevention (TSPP) in 1978 and adopted Protocols to MARPOL 1973 and SOLAS 1974. The Protocol to MARPOL 1973 includes the following requirements:

- New crude oil tankers of 20,000 tons dwt and above and new product carriers of 30,000 tons dwt and above are to be constructed with segregated ballast tanks in protectively located<sup>5</sup> areas.
- New crude oil tankers of 20,000 tons dwt and above are to be fitted with crude oil washing<sup>6</sup> (COW) system.
- Existing tankers of 40,000 tons dwt and above are to be fitted with either SBT or COW systems.

The Protocol provides for an interim period and for certain type of tankers to use dedicated clean ballast tanks<sup>7</sup>. MARPOL 73/78, which includes the protocol of 1978, entered into force on October 2, 1983 (IMO, 2000, p.5).

---

<sup>5</sup> Protective location means that the ballast tanks of the ship are positioned where the impact of collision or grounding is likely to be greatest. In this way the amount of cargo spilled after such an accident will be greatly reduced.

<sup>6</sup> Crude Oil Washing is the cleaning or washing of cargo tanks with high-pressure jets of crude oil. By the use of this system, the quantity of oil remaining on board after discharge is reduced.

<sup>7</sup> Dedicated clean ballast tanks - specific cargo tanks dedicated to carry only clean ballast water.

Additional safety measures for tankers were incorporated in the TSPP 1978 Protocol to the International Convention for the Safety of Life at Sea, 1974 (SOLAS 74). It includes the requirement for an Inert Gas System<sup>8</sup>(IGS) for tankers of 20,000 tons dwt and above. (IMO, 1997a, p.3). The 1978 TSPP Protocol relating to SOLAS 1974 entered into force in May 1981.

The world did not have to wait long to witness another major oil spill from a tanker. On March 16, 1978, just one month after the TSPP Conference, the supertanker *Amoco Cadiz* ran aground and broke into two, off the north- west coast of France, near Portsall, and spilled its entire 230,000 tons of crude oil cargo that resulted in a major environmental disaster between the coastal towns of Port Bano and Le Conquet (Cheeseman, 2001, p.1). Another oil spill from a tanker occurred in 1978 in the Shetland basin. The tanker *Esso Bernica* was holed while mooring and spilled 1,100 tons of heavy oil into the coastal waters (Patin, 1999, p.3).

While operational oil pollution from ships has been reduced considerably, accidental pollution continued, requiring continuous review of the provisions of MARPOL 73/78 and its amendments. The 1983 amendments to the Convention banned the carriage of oil in forepeak tanks (IMO, 1997a, p.5). The 1984 amendments mainly dealt with subdivision and stability of oil tankers and the 1991 amendments introduced a new chapter requiring ships to carry shipboard oil pollution emergency plan (SOPEP) (IMO, 2000, p.7)

Some of the major oil spills from tankers during the period 1979 to 1989 are as below.

<u>Ship name</u>	<u>Year</u>	<u>Location</u>	<u>Oil lost in tons</u>
<i>Atlantic Empress</i>	1979	off Tobago, West Indies	287,000

---

<sup>8</sup> The inert gas system- In this system the flammable gases in tanks are replaced by cleaned exhaust boiler flue gases with a low oxygen content and thus incombustible.



<i>Independenta</i>	1979	Bosphorus, Turkey	95,000
<i>Castillo de Bellver</i>	1983	off Saldanha Bay, South Africa	252,000
<i>Assimi</i>	1983	55 NM off Muscat, Oman	53,000
<i>Odyssey</i>	1988	700 NM off Nova Scotia, Canada	132,000
<i>Khark 5</i>	1989	120 NM off Atlantic coast of Morocco	80,000
<i>Exxon Valdez</i>	1989	Prince William Sound, Alaska, USA	37,000
<i>Aragon</i>	1989	on transit from Mexico to Spain	25,000

(Source: ITOPF, 2001, p.4)

In the wake of the *Exxon Valdez* disaster, the social and political climate in the United States at the time demanded action and the US Congress introduced a new Act in 1990. This event also led to some of the most important changes in MARPOL 73/ 78.

#### **4. The Exxon Valdez Disaster**

On March 24, 1989 the U.S. flag tanker *Exxon Valdez* ran aground at Bligh Reef in Prince William Sound, Alaska. After receiving 53 million gallons of crude oil cargo, the vessel sailed from Valdez pipeline terminal on 23<sup>rd</sup> March at 2126 hours for Long Beach, California. The weather that night was conducive for sailing although some growlers had drifted from the Columbia glacier. While manoeuvring through Prince William Sound, the vessel did not turn sharply enough and on 24<sup>th</sup> March at 0004 hours it grounded on Bligh Reef. The *Exxon Valdez* was one of the largest oil tankers at the time, built in 1986 and operating at a speed of 15 knots per hour (TED, 2000, pp. 1-2).

The impact of the grounding was so severe that the ripped cargo tanks spilled tons of oil into the sea so quickly that it created waves of oil about one meter above the water level. An estimated 11 million gallons of crude oil leaked into the environmentally sensitive Prince William Sound creating the worst oil spill in American history (TED, 2000, p.2). The spill spread over an area of more than 1,000 miles of the coast, and travelled nearly

470 miles Southwest from Bligh Reef. The oil coated the coastline of Alaska contaminating a national forest, four national wild life refuges, three national parks, five state parks, five state critical habitant areas, and a state game sanctuary (McFarland, 2000, p.2).

According to the oil response plan submitted by Alyeska, one of the conditions for the construction of the Trans Alaska Pipeline was that they would be at the site with response equipment within five hours of the spill. However, at the time of the *Exxon Valdez* spill the oil-containment equipment was not ready. It took ten hours for the clean up crew to reach the site and by that time oil slick had spread for miles (TED, 2000).

The clean up operations were carried out under the co-ordination of the ship owner and the US Coast Guard. The oil spill response consisted of the booming of environmentally sensitive areas, skimming corralled oil, cleaning up oil-laden beaches, wildlife rescue, and waste management. The oil spill response, salvage, and clean up efforts were extensive, time consuming and costly. It was conducted over a period of three years from 1989 to 1992 as a result of northern climatic conditions (McFarland, 2000, p.2).

Disasters like the *Exxon Valdez* grounding are news worthy and accessible to the media. Television and newspapers regularly provide the public with minute information (Griffin, 1999, p.1). The pictures of blackened beaches and oil soaked birds galvanize the minds of viewers of the harm done to the ecosystem. As a result, the public put pressure on national governments to take stronger measures to prevent future spills.

It was reported in Trade Environment Database (2000, p.2) that Alaska natives, fishermen and environmentalists have always been suspicious of the oil industry's foothold in the region for the potential risk of an oil spill. The *Exxon Valdez* incident sparked off a battle between the native Alaskans and the oil industry in the courtroom

and the press. The battle was over the responsibility for the accident as well as on the future of the region, the future of oil transportation and the oil spill response readiness.

A settlement was reached between the state of Alaska, the federal government, and Exxon Corporation in 1991. It was agreed that Exxon would pay the state of Alaska and the United States USD 900 million over a ten-year period in response to civil damage claims and USD 250 million in relation to criminal charges. Exxon had already spent over USD 2.1 billion on clean up costs. However, in October 2000, the US Supreme Court refused to release Exxon from the obligation to pay USD 5 million in punitive damages (Artic/ North Culture, 1999, pp. 1-2).

## **5. The Oil Pollution Act 1990 (OPA 90)**

In the wake of the *Exxon Valdez* oil spill the US Congress passed the Oil Pollution Act 1990 (OPA 90). It was signed into law on August 18, 1990. With regard to the *Exxon Valdez* oil spill, and the subsequent legislation and implementation of OPA 90, Pang and Williams (2001, p.1) state-

The *Exxon Valdez* spill caused legislators to act because of the size of the spill, its remote location, and its ecological impact. This legislation brought stricter regulations to the shipping and oil industries and led to the implementation of new regulations, for example the double-hulled tanker requirement.

The objectives of OPA 90 are prevention of oil spills, a comprehensive response regime for clean up in case of an oil spill, the assessment of penalties and liabilities to be paid by polluters for the damages caused, and punishment to polluters when appropriate (Loy, 1999, pp.1-2). A summary of the major provisions of the Act is set out below (OSIR, 2000, p.1):

### **5.1. Emergency response plans**

Owners of vessels are required to develop plans detailing the steps that they will take to respond to an oil spill. These plans must include contractual arrangements with the US based oil spill clean up organizations. Foreign ship owners must have their qualified designated persons based in USA. The vessel must be in possession of an emergency response plan approved by the US Coast Guard.

### **5.2. Double hull for tank vessels & single hull phase out**

Section 4115 of OPA 90 contains the double hull requirements and a phase out schedule for single hull tank vessels operating in US waters. According to this provision, all newly constructed tank ships must meet the double hull requirements. The phase-out dates for single hull tank ships of 5,000 GT and above are specified as a function of two variables with different dates. They are size groups with either double bottom or double hull construction. The size groups are: 5,000 – 15,000 GT, 15,000 – 30,000 GT, and 30,000 GT and above. In the present phase-out period single hull vessels up to 40 years of age are permitted for the two small sizes, with an additional five years for either double-hull or double-bottom. But a single hull vessel may not operate in US waters after January 1, 2010 and a vessel with only double bottom or double sides after January 1, 2015. (See Fig. 2). The double hull requirements do not apply to foreign vessels engaged in innocent passage.

### **5.3. Liability**

OPA 90 does not hold cargo owners liable for oil spills. Ship owners are subject to liability limits of USD 1,200 per gross ton of oil spill. The operators of such vessel are also rendered liable for oil pollution damage. The use of the term “operator” is very significant in that it could cover a whole host of potential defendants, including a pilot, a ship-management company and a mortgagee in possession.

### **5.4. OSLT fund**

OPA 90 has established a one billion dollar Oil Spill Liability Trust Fund (OSLTF). The federal government raises the fund from a five cent per barrel tax on oil. Third party

victims of an oil spill can submit claims against the fund. The US Coast Guard has access to the fund for distribution in case it is unable to locate the party responsible for the spill.

### 5.5. Navigational measures & State pre-emption

The Act requires a study of navigational measures undertaken by the US Coast Guard with the object of reducing oil spills. This may require prohibition of tanker movements in certain areas. The provisions of OPA 90 allow states in the U.S. to legislate and implement more stringent laws than the federal government, to protect their territories from oil pollution, to prevent occurrences and to deal with them in cases of oil pollution, in addition to imposing heavier penalties. Accordingly, many states have enacted more stringent laws in their jurisdictions.

## 6. MARPOL Regulations 13G AND 13F

After several spectacular tanker accidents, such as the *Exxon Valdez*, the *Khark 5*, the *Mega Borg*, political pressure started building up worldwide to put an end to catastrophic oil spills. Some of the major oil spills from tankers occurring during 1989 to 1992, which have influenced IMO to amend MARPOL 73/78 are noted below:

<u>Ship name</u>	<u>Date</u>	<u>Location</u>	<u>Oil lost in million gallons</u>
<i>Khark 5</i>	December 19, 1989	Atlantic ocean 185 KM away from Moroccan coast	20
<i>Cibro Savannah</i>	March 6, 1990	Linden, New Jersey	not known
<i>Mega Borg</i>	June 8, 1990	86 KM south west of Galveston, Texas	5.1
<i>Haven</i>	April 11, 1991	Genoa, Italy	42
<i>ABT Summer</i>	May 28, 1991	Atlantic ocean 1287 KM off Angola	15

(Source: OSIR, 2000)

Under the circumstances, the double hull amendments proposed by the United States in 1990 were accepted into MARPOL 73/78 with certain modifications. Alternative methods of design and construction ensuring the same level of protection against pollution in a collision or stranding were also incorporated (Griffin, 1999, pp. 12-14).

On March 6, 1992 amendments to MARPOL 73/78 were adopted, which added regulations 13F and 13G concerning the design and construction of both new<sup>9</sup> and existing tankers to Annex 1. The amendments came into force in July 1993. The essence of Regulation 13F is as follows:

- New oil tankers of 600 tons dwt and above are to be fitted with double hull, mid-deck or an other approved<sup>10</sup> alternative method of design and construction at least equivalent to double hull to prevent oil spills in the event of collision or stranding.
- Double hull tankers of 5,000 dwt and above, must be fitted with double bottoms and wing ballast tanks or spaces other than cargo and fuel oil tanks extending the full depth of the ship's side and the entire cargo tank length for the protection of cargo tanks.
- For mid-deck tankers, in addition to providing wing tanks as non-cargo spaces, the cargo and vapour pressure exerted on the inside of the bottom shell plating, forming a single boundary between the cargo and the sea, does not exceed the external hydrostatic water pressure.
- Oil tankers of 20,000 tons dwt and above have to comply with the damage assumptions prescribed to meet the assumed bottom raking damage.
- Oil tankers of less than 5,000 tons dwt must be fitted with double bottom tanks and the capacity of each cargo tank is limited to 700 cubic meters, unless they are fitted with double hulls.

---

<sup>9</sup> New oil tanker means a tanker for which the building contract was placed on or after July 6, 1993, or the keel was laid on or after January 6, 1994 or the delivery of which was on or after July 6, 1996.

<sup>10</sup> Approved means approved by Marine Environment Protection Committee (MEPC) based on the guidelines developed by IMO.

Regulation 13G, containing the IMO phase-out requirements for existing crude oil tankers of 20,000 tons dwt and above and product carriers of 30,000 tons dwt and above, took effect from July 6, 1995. It does not apply to tankers complying with regulation 13F. (See Fig. 2). The main provisions of regulation 13G are as follows:

- Existing oil tankers must be subject to an enhanced program of inspection (EPI), which must at least comply with the guidelines in IMO resolution A.744 (18), as amended.
- An oil tanker not meeting the TSPP 1978 requirements, must not operate later than 25 years after the date of delivery, unless it complies with the requirements of regulation 13F. However, an additional life of five years is possible, provided the tanker adopts either approved alternative operational arrangements, such as 'hydrostatic balance loading' (HBL), or meets the protective location requirements of paragraph 4 of the regulation.
- An oil tanker meeting the TSPP 1978 requirements, must not operate later than 30 years after the date of delivery, unless it complies with the requirements of regulation 13F.

Gray (1997, p.2) states that -

Regulation 13G, and its companion 13F requiring double hull, mid-deck or equivalent for new-building tankers, were developed in a group of feverish sessions at IMO which sought to reconcile the unilateral demands of the United States to impose OPA chapter and verse on the international fleet, and at the same time to deal with tanker design and construction features, both new and existing, on more rational and technically-based grounds that existed during U.S. Development of OPA.

While deliberating on the issue, the MEPC had the benefit of detailed studies conducted following the *Exxon Valdez* disaster. These included the results obtained from the

implementation of OPA 90 as well as the National Research Council's (NRC) study "Tanker Spills: Prevention by Design". The MEPC also conducted a comprehensive study on oil tanker design, which had participants from among the world's leading tanker design experts, shipyards and major classification societies.

## Upgrading Requirements

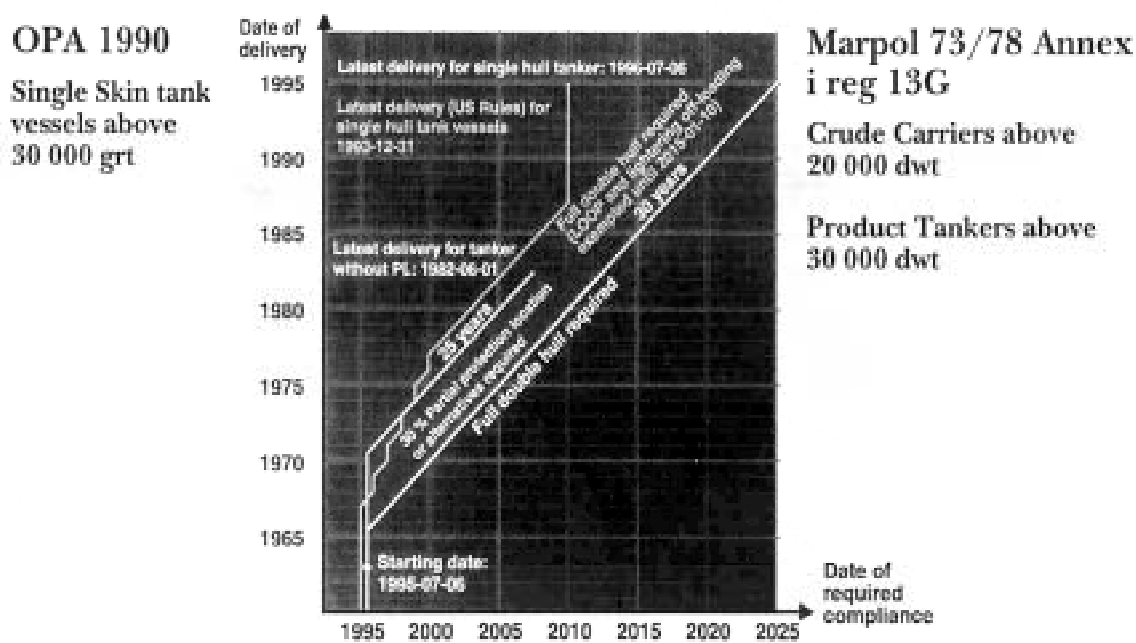

Fig. 2. Phasing out of single hull tankers under OPA 90 and MARPOL 73/78

(Source: DNV Paper series No. 97-P003, 1997)

The concept of 'enhanced program of inspection (EPI)' for oil tankers is called 'Enhanced Survey Program (ESP)' by the classification societies. Gray (1997, p.3) stresses that the concept, which was proposed by the tanker industry led by Intertanko, the International Chamber of Shipping (ICS), and the Liner Shipping Conference (LSC) in 1991, is clearly the most effective pollution prevention measure for dealing with existing substandard tankers. The basic principle of ESP is to have an extremely detailed and regular inspection of structure conducted by surveyors of the classification



societies with records of results maintained on board and available to interested parties such as Port State Control officers, charterers etc.

Although conversion of pre-TSPP 1978 single hull tankers to meet the protective location requirement of regulation 13G(4) can increase the life of a tanker to 30 years, it may require retrofitting partial bulkheads in cargo tanks, which can involve huge expenditure. Operation of such tankers without retrofitting and keeping large volumes of wing tanks empty or exclusively for ballast to meet the rule requirements may not be economically viable. As a result, ship owners may opt to scrap such single hull tankers rather than converting them, or adapting them to any other acceptable measures.

HBL is based on the principle that the hydrostatic pressure at the cargo tank bottom of the cargo oil column plus the ullage space inert gas overpressure remains equal to or less than the hydrostatic pressure of the outside water column, thereby mitigating the outflow of the oil in case of bottom damage. When grounded, the high pressure of the seawater pushes it into the tank forcing the cargo upwards and forming a seawater layer in the lower part of the tank. (See Fig. 3). Acceptance of this method by the administrations is based on the guidelines of IMO resolution MEPC 64(36). According to Gray (1997, p.4), the National Research Council report “ Tanker Spills: Prevention by design” speaks in a guarded way about HBL and expresses cautions. The report states that -

The effectiveness of hydrostatic control depends on operator’s strict adherence to rules, rather than on a permanent feature of vessel design and construction; and

Hydrostatic control does not provide complete protection against oil outflow due to tidal variations or wave action following a grounding.

It is this indent that the NRC is not favourably disposed towards hydrostatically balanced design options for new tank vessels.

The *Exxon Valdez* disaster, OPA 90 and Annex 1 regulations 13F and 13G of MARPOL 73/78 have altered the attention more towards tanker operational measures. It has brought in awareness in the shipping industry of the importance of safer ships and environment friendly ship performance.

Cargo capacity at 98% full tanks ..... : 463,673.6 m<sup>3</sup>  
Center tanks 98% full and and wing tanks loaded to 87.5% ..... : - 441,137.3 m<sup>3</sup>  
Cargo capacity reduction ..... : 22,536.3 m<sup>3</sup>

Cargo capacity reduction = 4.9 %

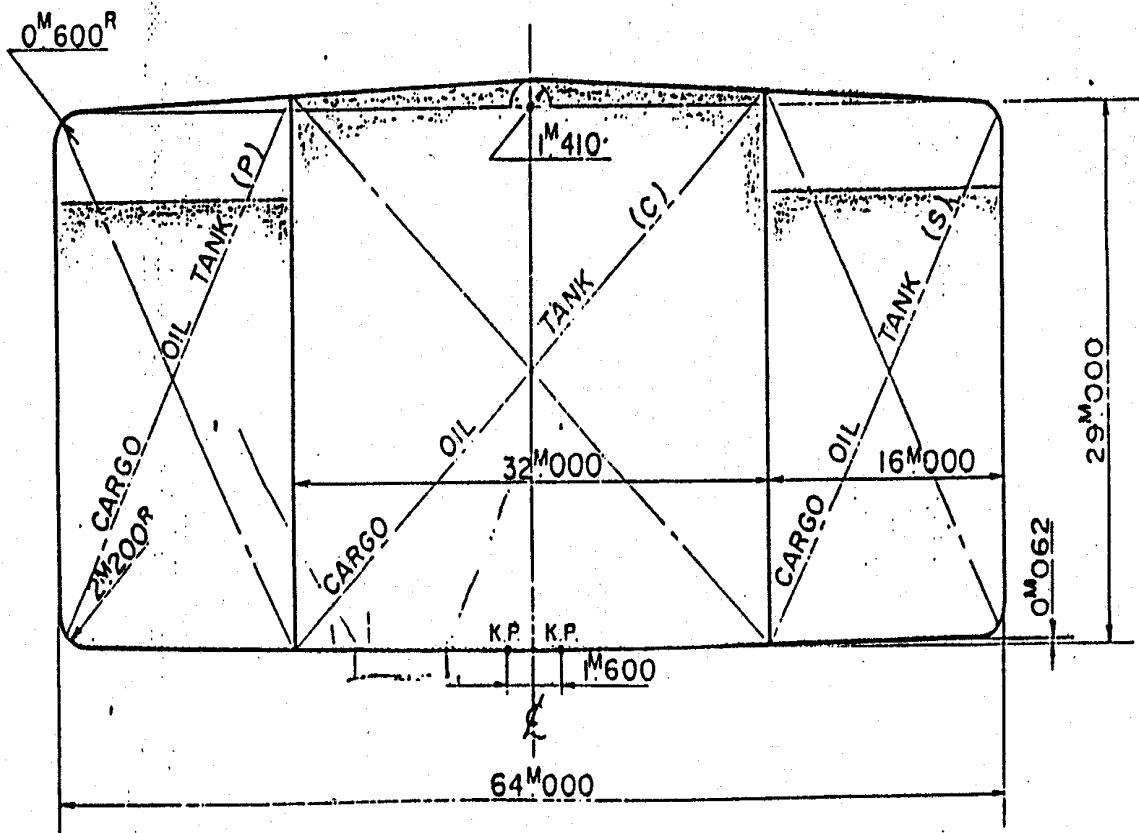

Fig. 3. Hydrostatically Balanced Loading

(Source: DNV Paper series No. 97-P003, 1997)

## CHAPTER 3

### The Erika Disaster and its Aftermath

#### 1. Introduction

Elimination of sub-standard ships and protection of the marine environment are issues, which have been discussed seriously by the shipping world in the past three decades. While operational and accidental pollution from ships have been reduced, with the increase in size and number of ships, the accidental pollution continues to occur. The international community creates hue and cry over any accidental oil pollution, which causes misery to the local population or affects the coastal ecosystem, and demands higher level of protection and preservation of the environment. The *Erika* disaster has caused such reverberations. The causes of the sinking of the *Erika*, the main players who contributed to the disaster, the reaction by the French authorities, the proposed European Commission directives and finally the changes adopted in the IMO single hull tanker phase-out schedule will be discussed in this chapter.

#### 2. The Erika Disaster

The 37,238 tons dwt tanker *Erika* broke into two in heavy seas, off the coast of Brittany, France, on December 12, 1999 while carrying approximately 30,000 tons of heavy fuel oil, and spilled about 15,000 tons of cargo. The entire crew of 26 was saved. The two sections of the vessel sank in 120 meters of water about 100 km from the mouth of the

river Loire. The spilled oil cargo was blown towards the French coast and polluted a 400 km long coastline, from Brittany to La Rochelle ('The Erika accident', 2000, p.2)

The 24-year old tanker *Erika* sailed under the Maltese flag. It was owned by the Savarese family of Sorrento in Italy through Teverse Shipping Company based at Valletta and Panship Management & Services, an Italian company, operated it. The *Erika* was classed with Registro Italiano Navale (RINA). The vessel was in possession of valid statutory and classification certificates issued by RINA after it carried out the five-year special survey in June 1998 and annual survey two weeks before the disaster. Prior to carrying out the special survey, the classification society of the ship was changed from Bureau Veritas (BV) following a change of ownership. On the fateful voyage, the *Erika* was under charter to TotalFinaElf carrying a cargo of heavy fuel oil from Dunkirk in northern France to Livorno in Italy. It was inspected under Port State Control (PSC) in Porto Torres in May 1999 and no deficiencies were reported. Also, PSC authorities in the port of Novorossiysk, Russia inspected it in November 1999 and a few deficiencies were noted ('Erika- principal', 2000, p.2).

The Malta's Maritime Authority (MMA) and the French Marine Accident Investigation Bureau (BMER) conducted separate official investigations into the cause of the *Erika* disaster. The MMA reported the cause for the loss as follows (Björkman (2000, p.1):

The loss was the result of several factors acting concurrently or occurring simultaneously... The most likely reasons for the loss were corrosion, cracking and local failure, vulnerabilities in the design of the ship, and the prevailing sea conditions... In 1998 the tanker underwent repairs at the Bijela shipyard in Montenegro...The low quality of the Bijela repairs could have contributed to the initial local failure, leading to the final collapse... The ship's managers were in attendance when these repairs were carried out, yet they failed to identify and/or address areas of significant local corrosion, nor did they monitor the repairs correctly.

From this part of the report, it can be seen that the MMA had identified local structural problems resulting from corrosion as the most probable cause of the sinking. Further, they criticized the shipyard repair in 1998 as minimal and in all probability insufficient. The shipyard's poor quality could have contributed to the initial local failure, leading to a final collapse ('French say', 2001, p.2).

The BMER investigation report has described the discovery of a serious loss of thickness of up to 30 % in hull plating and the replacement of 16mm plate with 12mm when the ship was repaired in the Bijela yard in Montenegro in August 1998. The repair work played a determining role in the chain of events that led to the accident. General rusting was widespread, and there were many patches of deep corrosion ('French say', 2001, p.2). The report states –

The Erika resembled a patchwork of metal sheets of different thickness and varied quality. The vessel would not have fallen apart if it had been as seaworthy as it was claimed to be by the classification society as late as 20 days before it broke up on December 12, 1999. There was excessive corrosion, beyond norms that are considered acceptable by classification societies.

Sub-standard welding was also noted on the ship. The existing state of the ship is summarized in the report as “In short, the state of the ship and its rapid deterioration in the final hours were such that there was no possibility of avoiding the catastrophe” ('Tanker so corroded', 2001, p.1; Parry, 2000, p.1).

Both reports criticized RINA, the Italian classification society. The BEMR discounted RINA's argument that the master of the vessel was partly to blame. They instead pointed to the areas of general corrosion, and the localized deep corrosion that led to the break up of the hull in tank No.2 starboard (Parry, 2000, p.1). From the investigation

reports of MMA and BMER, it can be concluded that the causes for the *Erika* catastrophe were corrosion and botched repairs, aggravated by rough sea conditions.

Many consider the *Erika* disaster to be the catalyst for a lookout to newer tankers to carry the world's oil production to the market. Older ships, of age 15-20 and more, are generally considered to be a liability for companies to charter them.

### **3. Fact or fiction**

The *Erika* spilled 15,000 tons of cargo oil when she broke into two, which was only 6.5% of the oil spill caused by the *Amoco Cadiz* in 1978 when it ran aground and broke into two in the same region. But the *Erika* disaster has stirred media interest and shipping industry repercussions more than that caused by the spill 22 years ago, as it broke apart while underway at sea. The French authorities have taken up the issue with IMO as well as with the European Union for immediate stringent measures to avoid recurrence of such incidents ('Erika provokes', 2000, p.2). The adequacy of the safety regime and the role of the main players responsible for the disaster are discussed below.

The quantity of oil spilled by the tanker *Erika* was not so large. But the disaster raises the question whether the present international maritime regime is adequate, or there exists weaknesses in the maritime safety rules that have contributed to the loss of the *Erika*. Intertanko is of the opinion that the provisions governing the design, equipment and operation of tankers are amongst the most rigorous of all IMO requirements ('Erika provokes', 2000, p.2; 'The Erika accident', 2000, p.3). Existing IMO conventions cover all the design and operation aspects of the *Erika* that could have contributed to the ship's sinking. The investigation reports of MMA and BMER point to the fact that the *Erika* accident occurred because the responsible parties were not implementing the safety

regime properly. The vessel was allowed to deteriorate to the point of break up. In the opinion of this writer, the responsibilities for the mishap lies firstly with the ship owners, followed by the classification society, flag state, and the charterer, which is discussed in the following paragraphs.

### **3.1. Shipowners**

Shipowners are responsible to maintain and operate ships in such a way that their ships are at least in compliance with the relevant IMO requirements and without diluting their obligations regarding safety, and protection of marine environment. Investigation reports of the *Erika* reveal that these norms have not been strictly adhered to. Renewing the hull plating by 12mm instead of 16mm thick plates, allowing wasting of hull plates to the extent of 30%, doing patchwork at plating areas of deep corrosion, etc. confirms the irresponsibility of the shipowners.

### **3.2. Classification societies**

Classification societies develop and administer the technical standards for the design, construction, and periodical surveys of ships, which are called the 'Rules'. The Rules are developed and updated on the basis of many years of experience from thousands of ships in service and on advanced research, theoretical and practical knowledge gained from experiments, and reflect the views of the whole industry (Abe, 1990, pp. 3-4).

Classification societies claim that they are independent and non-profit making third party organizations. It is this writer's opinion that generally, classification societies do their job well. But it cannot be denied that some of them play easy with shipowners, in order to procure more business and thereby more gross tonnage under their class. They compromise rigour by sharing the risk and responsibility with ship owners, for example, by allowing vessels to operate with existing deficiencies for a period of time. In many cases it is observed that when a ship is detained under PSC for any major structural

defect, the classification society of the ship issues condition of class to be dealt with in a short period, after the ship has carried out temporary repairs, which enables the ship to continue its operation. This may be a practical solution. But there is no reason for such a major deficiency to occur when the entire ship structure is subject to a systematic inspection at scheduled intervals. Secondly, in any case of a major deficiency, it has to be dealt with immediately.

Another factual observation is that some of the classification societies have dual standards even though they do not admit, as their rules are the same for all. Their standards vary from ship to ship depending on the owners, the flag of the ship, the area of operation of the ship, etc. This writer believes that often these factors contribute to the occurrence of disasters.

A third observation is about the regional standards of some of the classification societies. Classification society surveyors, sometimes, follow regional standards and practices, which may be below the standards set up by their rules. Finally, shortage of experienced, trained and qualified surveyors may also be a contributing factor.

### **3.3. Flag States**

In various IMO Conventions it is made clear that the flag state, which is signatory to the Convention, has full and formal responsibility for taking all measures deemed necessary to give the Convention full and complete effect. According to Article 1 of SOLAS 1974, the Administration is obliged to promulgate all laws, decrees, orders and legislation and to take all other steps, which may be necessary to ensure that a ship is fit for the service for which it is intended. The Administration is responsible for taking the necessary measures to ensure that ships flying its flag comply with the provisions of relevant Conventions. The Administration may delegate the execution of its obligation



to others, for example to classification societies, to carry out statutory surveys but it cannot delegate nor absolve the responsibility for shouldering it (Jönsson, 2000, pp.1-4).

### **3.4. Port States**

In the past two decades, PSC inspections have helped to eradicate the operation of substandard ships to some extent. Under various regional Memoranda of understanding (MOU) covering all the oceans and sea, PSC has created a sense of awareness among shipowners and operators that they have to properly maintain their ships to avoid being detained in ports. But PSC inspections have their limitations. As a normal inspection under port state control takes only two to four hours, it may not reveal a serious structural defect when the ship's records and classification listings do not reveal it. The ship may appear good superficially, and it may not be practicable to inspect all the ballast or cargo spaces, unless the Port State Control Officer (PSCO) suspects a defect or receives such information. Co-operation of the crew is essential for a successful PSC inspection, which may not be easily available due to various constraints. In the condition and circumstances explained, it is this writer's opinion that a PSC inspection of the *Erika* might also not have revealed its serious structural deficiencies.

To substantiate this writer's view on the above, a specific PSC inspection is narrated below. In 1994, a gas carrier named *Coral Star* of Panama flag called at Port of Cochin in India to receive drinking water and provision for the crew. It was built in 1972, owned by an Italian shipping company and classed with RINA. The PSCO, who was suspicious of the circumstances of the vessel's call to the port, boarded the ship for an inspection. All the vessel's records were found to be in order, fire fighting arrangement and life saving equipment were in satisfactory condition, and the engine room spaces and machinery were properly maintained. Also, crew did not inform the PSCO of any defects. The master informed the PSCO that the ship had encountered cyclonic weather

during the voyage, had exhausted the supply of drinking water and provisions, and had therefore called into the port.

The PSCO observed that the classification surveyor had carried out a safety equipment survey about two weeks earlier and the vessel had undergone dry-docking repairs recently. However, just by sheer coincidence, the PSCO inspected the void space in the cargo area. To his dismay, the ship's double bottom ballast tank tops were found corroded and transversally cracked at a few places. The collision bulkhead was also corroded and leaking. If the cracks on the tank tops, which were adjacent to the hull plating, had travelled to the hull with the stresses induced by rough seas, it could have ended up in a disaster.

### **3.5. Charterers**

The charterers have an obligation to recognize and support quality shipping by doing everything in their power to identify substandard ships and avoid any association with them ('Erika provokes', 2000, pp.2-3; 'The Erika accident', 2000, p.4). Charterers can effect improvements to the current safety regime by tightening their vetting and approval procedures during selection of ships for chartering.

Therefore, in order to eradicate substandard ships, shipowners, classification societies, flag states, port states, charterers, and ship's crew must all cooperate.

## **4. Aftermath in Europe**

### **4.1. The French action**

The Government of France, in a unilateral move, have introduced rigorous new national tanker shipping safety rules in its drive for tighter European Rules. TotalFina, Elf and the French subsidiaries of BP, Shell and Esso signed a voluntary tanker shipping safety charter sponsored by the French Government, which promises to introduce stricter

checks on tankers over 15 years of age and to cease using single hull tankers by 2008. A number of other French shippers' organizations, Ship owner's Central Committee and Bureau Veritas have also signed (IRI, 2000. p.1).

#### **4.2. The European Commission directives**

The public outcry over the pollution damage caused by the *Erika* disaster has provoked a massive and radical reaction from the European Commission (EC), the French Government, classification societies, environmental campaigners and others. The reaction was so strong that it was felt that nearly every aspect of pollution law might undergo radical change within few years. Many felt that the reaction was abrupt and hasty. Following the energetic representation of the French Government, the EC proposed legislation, which was described as 'more wide ranging and more draconian than the US OPA 90' and hence dubbed as 'Eur OPA 2000' (Leech, 2000, pp. 1-3).

##### **4.2.1. Erika I-package**

The post-Erika package labelled as 'Erika I-package' was presented by the EC in March 2000. It contains amendments to the existing EC directives on Port State Control, classification societies, and new scheme for faster phasing out of single hull tankers in European trades ('The Erika accident', 2000, pp. 5-6).

The proposed amendment on PSC includes enhanced surveys for tankers over 15 years, increased flow of information between classification societies, PSC and flag states, listing of the charterer in a PSC detention data and banning of vessels older than 15 years which have been detained more than twice. The proposed directive on classification societies includes the increased possibility for the Commission to prevent non-performing classification societies from doing statutory work for member states, an increased surveillance of their quality standards and for a harmonized European system for liability of classification societies.

The proposal for accelerated phasing out of single hull tankers in European waters, based on OPA 90, basically contains the following elements:

- Phasing-out of single hull non-TSPP 1978 tankers by 2005, single hull TSPP 1978 tankers by 2010, and single hull tankers below 20,000 tons dwt by 2015;
- Removal of the provision for HBL made under the MARPOL Convention; and
- Introduction of financial incentives for operating double hull tankers or tankers exhibiting similar safety characteristics.

Many issues on this list of amendments are creating difficulties for the EU Commission, the Council and the Parliament to reach a common view. As regards the proposal for the accelerated phasing-out of single hull tankers, the IMO has gone a long way to accommodate the EU's positions. In view of the decisions emanating from the 46<sup>th</sup> session of the MEPC in April 2001, it seems highly likely that the regional rules in Europe will be avoided (The Indian Mariner's News Desk, 2000a, p.1; The Indian Mariner's News Desk, 2000b, p.1; 'In the wake' 2000, p.1; 'The Erika accident', 2000, pp. 5-6).

#### **4.2.2. Erika II-package**

The second package presented by the Commission on 6<sup>th</sup> December 2000, contains the following new far reaching proposals:

- Improved VTS<sup>1</sup> in European waters
- Establishment of European Maritime Safety Agency
- International oil compensation regime
- Increased transparency (EQUASIS<sup>2</sup>)

---

<sup>1</sup> Vessel Traffic Services contribute to the safety of life at sea, safety and efficiency of navigation and protection of maritime environment, adjacent shore areas, work sites and offshore installation from possible adverse effects of maritime traffic. IMO resolution 857(20), SOLAS regulation V/ 12, MSC circular 952, IALA recommendation V/ 103, and Maritime and Coast Guard Agency – MGN 109 (M+F) are the existing instruments dealing with the requirement of VTS.

These proposals will have to undergo the decision making process of the Council as well as the Parliament, as in the case of the ‘Erika I-package’. The Erika II-package is also bound to confront the tanker industry with far reaching practical and tactical challenges (The Indian Mariner’s News Desk, 2000b, p.1; EU – EP, 2001, pp. 1-2).

## **5. Single-hull phase out – Revised timetable**

At the 46<sup>th</sup> session of the MEPC held in April 2001, IMO agreed to a revised timetable for elimination of single-hull tankers by 2015 or earlier. The new phase-out timetable will be included by amending regulation 13G of Annex 1 of MARPOL 73/78 and will enter into force in September 2002. The content of the revised timetable is as follows (IMO, 2001b, pp. 1-2; True, 2001, pp. 68-69):

### **5.1. Three categories of tankers**

The new regulation identifies three categories of tankers as below:

Category 1 - oil tankers of 20,000 tons dwt and above carrying crude oil, fuel oil, heavy diesel oil or lubricating oil as cargo, and of 30,000 tons dwt and above carrying other oils as cargo, which do not comply with the PL/ SBT requirements.

Category 2 - oil tankers of 20,000 tons dwt and above carrying crude oil, fuel oil, heavy diesel oil or lubricating oil as cargo, and 30,000 tons dwt and above carrying other oils, which comply with the PL/ SBT requirements.

Category 3 - oil tankers of 5,000 tons dwt and above but less than the tonnage specified for Categories 1 and 2.

---

<sup>2</sup> On January 28, 2000, the maritime administrations of France, United Kingdom, Spain, Singapore, US Coast Guard and European Commission signed an agreement to set up a ship safety database formally known as Equasis information system that is aimed at eradicating dangerous vessels. Equasis will be collecting safety-related information on the world’s merchant fleet from both public and private sources and making it easily accessible on the Internet. This database will include information of Port State Control inspections as well as detention information from France, Far East, and United States, along with industry details such as classification, insurance and participation in inspection schemes (Equasis, 2000)

## **5.2. Exemption**

With the revised regulation I/13G of MARPOL, although 2015 is set as the new cut-off date for phasing-out single hull tankers, the flag administration may allow some newer single hull ships registered with them and conformed to certain technical specifications, to continue trading until the 25<sup>th</sup> anniversary of their delivery. However, any port state can deny entry of such single hull tankers to their ports or offshore terminals, but they must communicate their intention to IMO (IMO, 2001b, p.2).

## **5.3. Condition Assessment Scheme (CAS)**

MEPC in its 46<sup>th</sup> session adopted a resolution on the Condition Assessment Scheme, which will be applied to all Category 1 vessels continuing to trade after 2005 and all Category 2 vessels after 2010. The requirements of the CAS include enhanced and transparent verification of the reported structural condition of the ship and verification that documentary and survey procedures have been properly carried out and completed. Further, the scheme requires that compliance of CAS be addressed during the ESP concurrent with intermediate or renewal surveys as required by resolution A.744 (18), as amended (IMO, 2001b, p.2).

## **6. Other Post-Erika Amendments**

In October 2000, the IMO adopted amendments to the CLC and the IOPC Fund Convention and raised the limits of compensation by 50%, payable to victims of pollution by oil from tankers. In December 2000, amendments to the guidelines on the EPI<sup>3</sup> during surveys of bulk carriers and oil tankers in relation to the evaluation of the longitudinal strength of the hull girder of oil tankers were also adopted. In response to

---

<sup>3</sup> Amendments to resolution A.744 (18) Guidelines on the enhanced program of inspection during surveys of bulk carriers and oil tankers, 1993.

the Erika incident, the IMO has taken action on several other operational matters aimed at enhancing safety and minimizing the risk of oil pollution (IMO, 2001b, p.2).

To summarise, even though the international maritime regime does cover the entire spectrum of safety in design, construction and operation of ships, safety of people and environment, the accidents still occur mainly because some responsible parties are not properly implementing the safety regime. Accidents, like the sinking of the *Erika*, occur due to the casual and irresponsible attitude of some ship owners, operators, classification societies, flag states, charterers, etc. Most of the accidents pave way to public outcry and become a whip in the hands of the lawmakers to adopt and implement the new laws, mostly to satisfy the aroused public. This indeed becomes punishment to the innocent and responsible shipowners and operators.

In the IMO accelerated phasing-out or ‘Dead Drop’ requirements of single-hull tankers, even many well-maintained tankers will have to accept premature death and go to the graveyard before completing the normal life span. The consequences of such hasty actions may seed direct and indirect harm to the shipping industry. The oil price may shoot up. The shipowners may hesitate to buy stronger and costlier ships.

## CHAPTER 4

### Design Characteristics of Double Hull Tankers

#### 1. Introduction

Since June 1990 the OPA 90 has required all new tankers trading in USA to have double hull, and since July 1993 the IMO has set out a phased program requiring all new tankers trading worldwide to have double hull or equivalent design. Magelssen (1997, p.2) states-

By introducing these Rules it is concluded by the Rule-makers that a possible oil spill after a collision or grounding will be reduced for a double hull tanker.

With the introduction of these rules, the world tanker fleet has been changing slowly to double hull in the beginning and then gathering momentum gradually. The statistics published by Intertanko ('Tanker transport', 1999, p.4) show that the majority of the world tanker fleet is still made up of single hull, but the proportion of the double hull tankers has increased from 4% in 1990, to 10% in 1994, and some 27% in 1999. They have estimated that by 2002 double hull tankers will account for 50% of the world tanker fleet.

The effectiveness of the present regulations regarding the construction and operation of double hull tankers is the main concern both from an environmental as well as a commercial perspective. In this chapter, first the salient points of the double hull tanker regulations will be addressed, then the problems faced in double hull tanker design and



construction will be discussed, and finally, some of the alternative double hull tanker designs will be briefly presented.

## **2. Regulatory features**

We have seen in Chapter 2 that the OPA 90 and the regulation 13F of Annex I [I/13F(3)]<sup>1</sup> of MARPOL 73/78 require construction of all new oil tankers of 5,000 tons dwt and above to be double hull. Regulation I/13F(3) requires that the entire cargo tank length is to be protected by ballast tanks or spaces other than cargo and fuel oil tanks, in addition to stipulating the minimum height, depth and width of these tanks and spaces. The requirements are summarized as follows:

- the wing tanks or spaces are to be extending either for full depth of the ship's side or from the top of the double bottoms to the uppermost deck;
- the minimum width at any point of the wing tanks or spaces shall not be less than calculated from the formula given in the regulation or two meters which ever is less, but not less than the minimum value of one meter;
- the double bottom tanks or spaces are to be extending either from side shell to side shell, or from side tank or space to side tank or space;
- the minimum depth at any cross-section of the double bottom tanks or spaces shall not be less than  $B/15$  (meter) or 2 m which ever is less, but not less than one meter;
- if the side tanks are common to the double bottom or a portion of it, the tanks are generally J or L tanks in order to comply with the regulation I/25A.

Regulation I/25A, which came into force on February 1, 1999, practically requires longitudinal central bulkheads in order to comply with the intact stability criteria.

---

<sup>1</sup> Regulation I/13F(3) means regulation 13F(3) of Annex 1

Regulation 13F(3) also deals with other details such as turn of the bilge area, aggregate capacity of ballast tanks, suction wells in cargo tanks, and ballast and cargo piping. Oil tankers of less than 5,000 tons dwt must at least be fitted with double bottom tanks or spaces having a depth of  $B/15$  (meter) with a minimum value of 0.76 m. The regulations do not mention the requirement of side tanks or space for oil tankers of this size category. However, the capacity of cargo tanks cannot exceed  $700 \text{ m}^3$  unless fitted with wing tanks or space complying with the requirements stated earlier.

### **3. Design & Construction problems**

The double hull concept simply means that the cargo oil tanks are separated from the outer hull by means of a space large enough to absorb low-speed impacts. Fig 4 shows midship section with nomenclature of a typical double hull tanker. Björkman (1992, p.321) says that the most obvious structural solution to this requirement is to build the double hull of sandwich panels. The sandwich panels mean that the webs and stiffeners of inner and outer shells will be inside the double hull.

With the implementation of double hull regulations, the geometrical structure of oil tankers has undergone changes. According to Magelssen (1996, p.2), the change in length/draught ( $L/D$ ) is from approximately 11.5 to 10, with considerable reduction in scantling. Particularly with the use of high tensile steel (HTS), the critical buckling stresses will often exceed the acceptable corrosion limit applicable to pre-MARPOL designs. A double hull ship built with HTS in deck and bottom area will have a ratio of 30-40 % between HTS and mild steel.

For small size double hull tankers the regulation requires more ballast volume than that for single hull ships of the same size. Magelssen (1996, p.2) clarifies that the requirement for more ballast volume reduces with the increase in size of the vessel, and

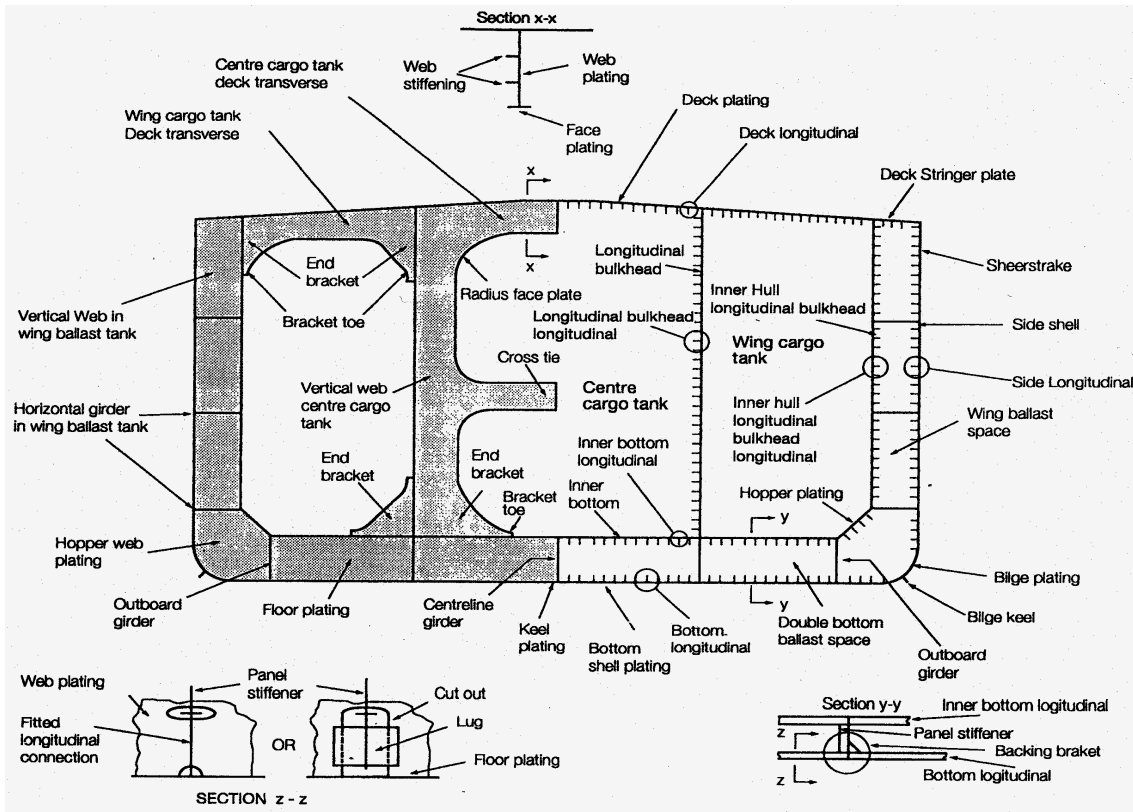

Fig. 4. Typical double hull midship section nomenclature

(Source: Tanker Structure Co-operative Forum)

for ships of 80- 100,000 tons dwt, there may not be any difference. But the area exposed for ballast will be between 2-3 times more in double hull tankers than in single hull tankers of the same size. This means that more area is exposed to possible corrosion requiring protection by coating and access to the structure, involving additional expenditure.

Magelssen (1996, p.2) foresees that for large double hull tankers, ballast conditions involving filling up of all ballast tanks may give rise to a high still-water bending moment. To reduce this effect, forepeak tanks may have to be only partially filled. For

tankers designed without longitudinal bulkheads and built before regulation 25A entered into force, stability will be another area requiring attention.

In a conventional double hull tanker, because of the mandatory even distribution of cargo oil tanks and ballast water tanks, hull girder bending moments are higher than for single hull tankers in both the loaded and ballast conditions (Hah and Akiba, 1994, p.268). This results in high hull girder bending stresses throughout the ship's life.

Björkman (1992, p.321) explains the difficulties associated with the design of a double hull tanker with a small distance between inner and outer shell plates, which houses the webs and stiffeners as follow:

- complex task to calculate the combined stresses and buckling strength as static and dynamic loads stress the shell plates longitudinally, transversally and laterally;
- cumbersome to carry out the manual welding due to the restricted access for welding stiffeners to webs inside the double hull space;
- corrosion protection by coating and anodes for the double hull space, used to carry ballast water, becomes a major concern due to the maximum structure inside the space;
- easy access and ventilation are to be incorporated to facilitate removal of ballast water sediments, for general cleaning, maintenance and inspection, and for monitoring presence of gas leak within the sandwiched double hull space.

It is difficult to carry out proper welding in the narrow space between the inner and outer shell congested with webs and stiffeners. A welder may not be able to position himself properly at many locations in order to carry out welding. There may not be sufficient ventilation in the space and the smoke and heat generated by welding cannot escape easily. Further, access for welding to many areas may be difficult. The welder will feel

fatigued soon. All these factors can result in poor workmanship and welding quality. Another factor requiring consideration is the amount of welding to be carried out in the congested double skin space. As there is an additional hull compared to a single hull tanker, the welding length in the double hull space is almost double. The amount of work for the yard quality control department, statutory surveyors and classification surveyors carrying out welding inspection will also increase considerably. Also, the possibility of human error while carrying out tedious inspections in congested space cannot be ignored.

#### **4. Alternative Double Hull designs**

In order to overcome some of the major design and construction difficulties, Björkman (1992, pp. 321-328) describes the following five pairs of alternative designs complying with the double hull regime. To demonstrate the alternatives, he has used 280,000 tons dwt VLCC with the following approximate particulars: Length: 320 m, Breadth: 57.5 m, Depth: 30.3 m, Draught: 21 m, Cargo capacity: 330,000 m<sup>3</sup>, Ballast capacity including peak tanks: 105,000 m<sup>3</sup>, cargo tank body length: 255 m and web spacing: 5.32 m.

MARPOL cargo tank size limitations are met by the suitable location of longitudinal bulkheads. Each figure from 5 to 14 shows a simple cargo tank layout at the top, a transverse web section at the middle, and primary supports on the transverse bulkhead and the access trunks to the double bottom tanks at the bottom

#### 4.1. Alternatives A1 and A2

Figs. 5 and 6 are two alternatives A1 and A2, where the double hull spaces at sides and bottom have a uniform distance between inner and outer skins of 3.5 m. There are four pairs of side and double bottom ballast tanks. The main difference between A1 and A2 is in the web fitting of the longitudinal bulkhead separating centre and side cargo tanks. In A1, the web is fitted at the centre cargo tank side, whereas in A2 it is at the side cargo tank side. The access to the double bottom tank is via trunks incorporated in a vertical web on the transverse bulkhead and a longitudinal bulkhead web. The inner and outer side shell stiffeners are located inside the double skin space. These designs incorporate all the four problems, described earlier.

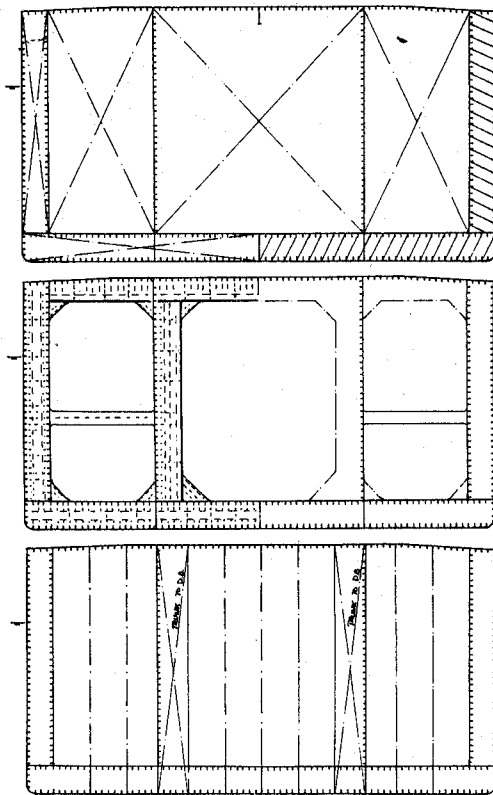

Fig. 5. Alternative A1

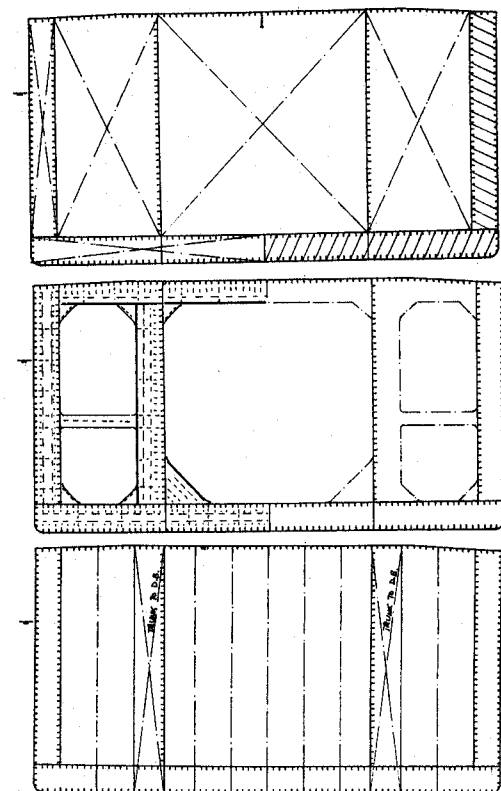

Fig. 6. Alternative A2

(Source: The Naval Architecture, 1992 June, p.321)

#### 4.2. Alternatives B1 and B2

Figs. 7 and 8 show alternatives B1 and B2, which have 2 m deep double bottom tanks and 5 m wide side tanks. The inner bottom longitudinals are fitted in the cargo tanks. As the double bottom is not a sandwich construction, carrying out assembly welding in this space is easier. Further, welding inside the space is limited to upside welding of the web and vertical stiffeners to the inner bottom shell. The inner bottom plate is subject to less transverse stresses because its position is close to the neutral axis of the bottom web. The bottom web flanges take the maximum stresses. Access to the double bottom space is similar to A1 and A2.

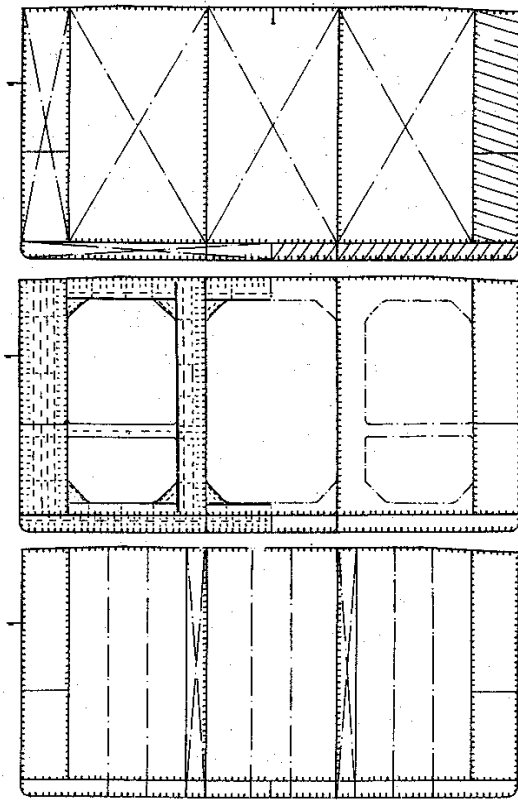

Fig. 7. Alternative B1

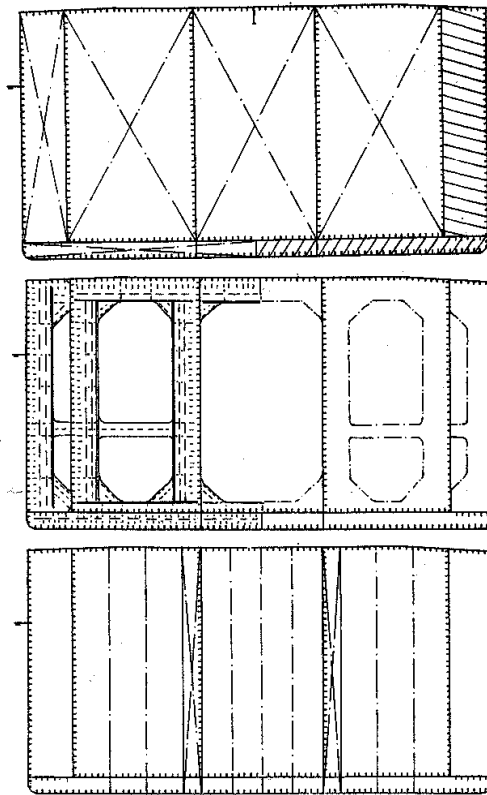

Fig. 8. Alternative B2

(Source: The Naval Architecture, 1992 June, p.321)

Although in B1 the inner side shell stiffeners are located in the ballast tanks, they are not sandwich panels as there is sufficient width between inner and outer shells and the two panels are joined at the web. In B2 the inner side shell stiffeners are located in the side cargo tank. The conventional web beams support the inner and outer shells and the quantity of steel structure in ballast tanks is reduced.

In B1 and B2 the side ballast tanks can carry about 70% of the ballast. As these tanks are wider in construction, they can be easily cleaned and ventilated. The double bottom tanks may need to carry less quantity of ballast water as peak tanks can also be used for ballast. This facilitates filling of double bottom ballast tanks in the open clean sea and avoids ballast sediments collecting in the tanks.

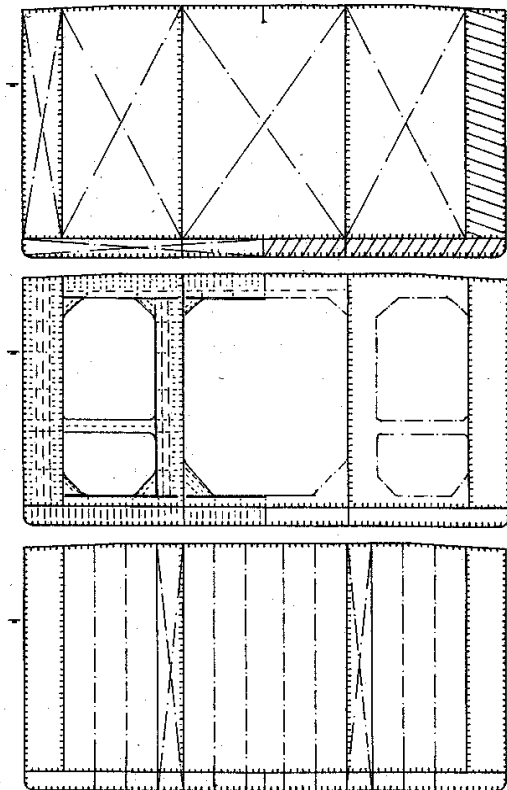

Fig. 9. Alternative C1

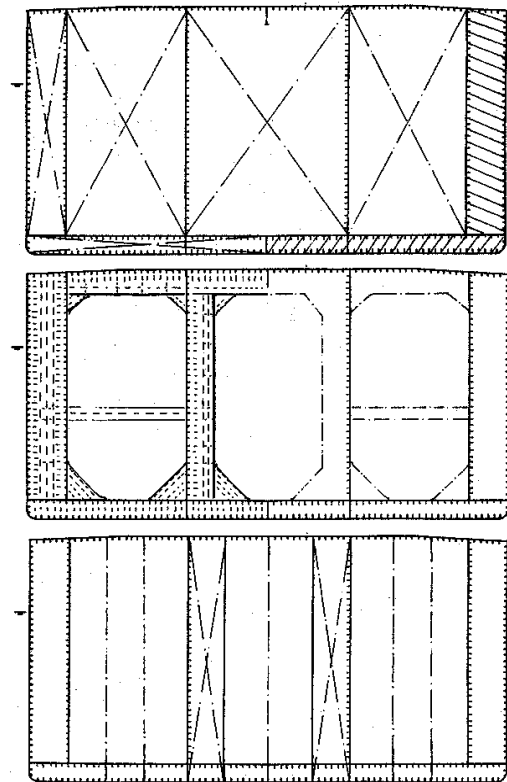

Fig. 10. Alternative C2

(Source: The Naval Architecture, 1992 June, p.321)



### 4.3. Alternatives C1 and C2

Figures 9 and 10 show alternatives C1 and C2, where the double bottom tanks are 2.33 meters deep and the double side tanks are 4.66 meters wide. The difference between C1 and C2 is in the location of longitudinal bulkhead web between the side and central cargo tanks and the construction of double bottom. In C1, web fitting of the longitudinal bulkhead is in the side cargo tank, whereas in C2 it is in the central cargo tank. Similarly, the inner bottom longitudinals are fitted in the cargo tanks side in C1, whereas it is fitted in double bottom in C2.

### 4.4. Alternatives D1 and D2

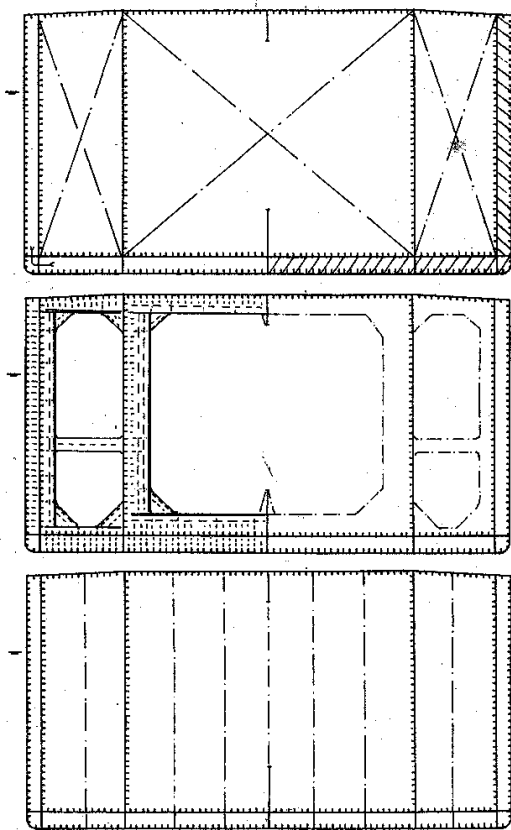

Fig. 11. Alternative D1

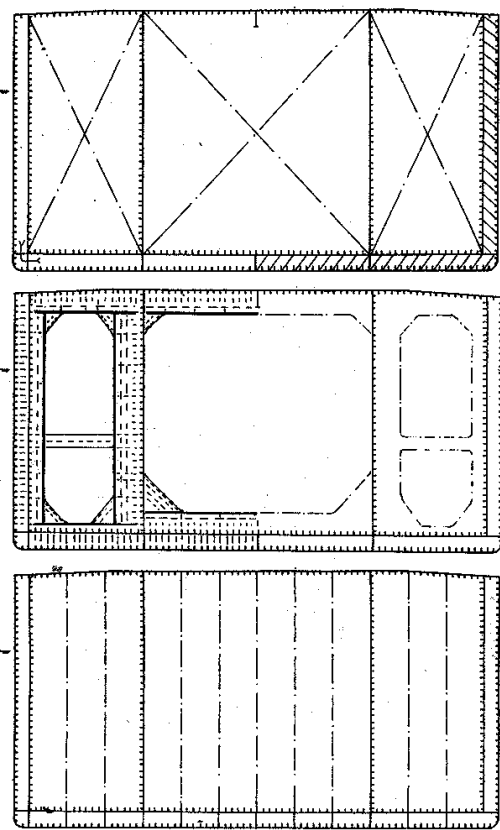

Fig. 12. Alternative D2

(Source: The Naval Architecture, 1992 June, p.323)

Figures 11 and 12 show alternatives D1 and D2. The alternatives have 2m wide double hull with inner shell stiffened in the cargo tanks. The double bottom is not of a sandwich construction, but with two panels fitted on top of each other, similar to B1 and B2, with the inner shell plate located close to the transverse web frame neutral axis. As the double hull space used for carrying ballast water has only 2m widths, this space alone cannot carry adequate quantity of ballast water to meet the MARPOL requirements. Either one centre tank or a pair of side tanks must be allocated for ballast purposes. Further, it may be possible to arrange four U-shaped ballast tanks in the double hull cargo body, meeting the requirements of regulation I/25A. Such an arrangement can facilitate easy ventilation of these tanks from one side to other.

#### 4.5. Alternatives E1 and E2

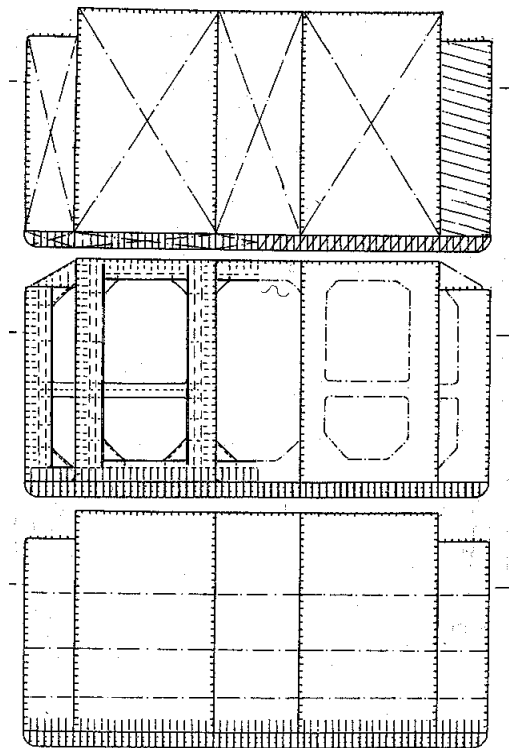

Fig. 13. Alternative E1

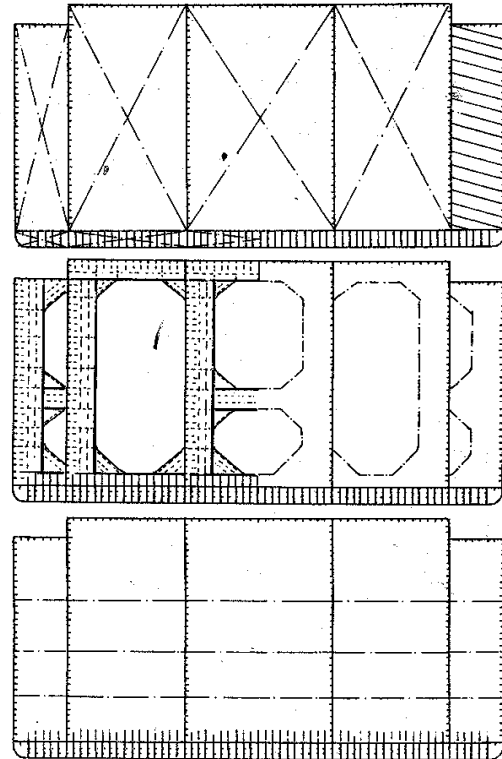

Fig. 14. Alternative E2

(Source: The Naval Architecture, 1992 June, p.323)

Figures 13 and 14 show alternatives E1 and E2. The main difference between E1 and E2, and other alternatives is in the design of the double bottom tanks. Other alternatives have transverse webs inside double bottom supporting the outer shell longitudinals. In E1 and E2, one longitudinal girder with two longitudinal stiffeners replaces the inner and outer shell bottom longitudinals. The unidirectional stiffened double bottom has no transverse webs inside the double bottom. The transverse webs inside the cargo tanks support the longitudinal girders. The difference between alternative E1 and E2 is that in the former the longitudinal bulkhead web is in the wing tanks and in the latter it is in the centre tank.

The double bottom space consists of five double bottom tanks extending the entire length of the tank body. There are two accesses in each double bottom tank, one at the collision bulkhead and the other from the pump room. The advantages of these designs are the ease in cleaning and ventilating the double bottom tanks. The tanks can be ventilated from forward to aft. Similarly, with an after trim the tanks can be washed to the after side and the sediments collecting near to the pump room can be easily pumped out. Further, it is easy to fabricate the unidirectional stiffened double bottom with the absence of web connections and stiffeners in the space. As double bottom space does not require access in the tank body, the transverse bulkheads are vertically stiffened with horizontal stringers as support. During the ballasting process, the double bottom ballast tanks should be ballasted at the last stage in clear seas to avoid collection of sediments. It may be possible even to avoid ballasting of double bottom tanks in case the side tanks are large enough to take the required ballast.

Even though alternatives E1 & E2 are superior to other alternatives, Björkman expresses his dissatisfaction for various reasons. Many yards and owners go for sandwich panels and then try to remedy the difficulties through additional arrangements such as vent/purge pipes in the ballast tanks, fixed gas detection system, etc. It is known that a

double hull tanker requires extra steel for construction as compared to a monohull tanker. But the steel should be arranged to locate high stresses in safe places, facilitate access and ventilation and allow collection of sediments in easy locations for removal.

To conclude, double hull for new tankers has become a mandatory requirement by amendment to the MARPOL 73/78 Convention and the OPA 90, although alternative designs providing equivalent protection are also acceptable under the former. Basically, the double hull concept requires cargo oil tanks to be separated from the outer hull by a space large enough to absorb low energy impacts. MARPOL regulations specify minimum dimensional requirements for this space.

With the change in geometrical structure of the hull, there may be considerable reduction in scantlings in double hull tankers. Further, the critical buckling stresses often exceed the acceptable corrosion limit, particularly with the use of HTS. For a large double hull tanker on a ballast passage with all ballast tanks full, the condition may give rise to a high still water bending moment. Carrying out welding and quality inspection with restricted access inside the double hull space is cumbersome and can adversely affect in the quality of welding. In addition to many technical problems and difficulties with regard to the design and construction, double hull tankers are costlier than single hull tankers with the use of more steel for construction.

## CHAPTER 5

### Double Hull Tanker Concerns

#### 1. Introduction

Long-term preservation of anything that resides in an exposed environment is a difficult objective, and this is particularly true for ships operating in the marine environment. The old saying “corrosion never sleeps” is definitely true, but Birkholz (1997, pp.1-4) opines that this may be a little understated, as corrosion actually appears to go on binges. Coatings are the primary line of defence against corrosion as they work to keep the oxygen and moisture away from the metal. Present day coatings available are mostly “surface tolerant”<sup>1</sup>

Many critics have pointed out that a conventional double hull tanker has numerous potential operation problems. Magelssen (1996, pp.2-4) has listed some of them, which include cargo leak to ballast tanks from explosion and pollution points of view, maintenance of corrosion coating in extended ballast area, difficult pipe replacement, problems in ventilating the ballast tanks, difficulties in fire fighting due to less heat transfer, and stability problems without longitudinal bulkheads in cargo area.

The focus of this chapter is to discuss various operational problems faced and the risks involved in double hull tankers. First the difficulties for inspection, monitoring,

---

<sup>1</sup> Surface tolerant coatings can be applied over a less than well-prepared surface.

cleaning and maintenance of double hull ballast space will be discussed together with the effects of free surface and sloshing. This will be followed by a discussion on corrosion and fatigue risks, and finally, an analysis on the structural failures in double hull tankers will be presented.

## **2. Potential operational problems**

### **2.1. Problems relating to ballast space**

The complexities involved in double hull tanker construction, which include a proliferation of webs and stiffeners in narrow spaces between double shells, cause many operational problems and difficulties. Hah & Akiba (1994, p.268) point out some of them, which are explained in the following five paragraphs.

A double hull tanker has vast boundary areas between the cargo tanks and ballast tanks as well as between the sea and water ballast tanks. Inspection of these entire spaces is cumbersome. The ballast tanks will be humid, wet, dark and slippery, and hence are not assessable to proper inspection. The performance and reliability of oil and vapour leak detection systems in double hull spaces have not been proved successful. Such systems are difficult to be kept in proper operational condition in such locations.

It is difficult to remove any oil leaking into the ballast space and the risk of oil pollution is high when ballast water is discharged into the sea. Accumulation of dirt and sand in ballast tanks cannot be avoided when the ship has to ballast dirty seawater in order to maintain stability and control structural stresses. Removal of dirt and sand from double bottom and narrow double side tanks is difficult.

In a double hull tanker, ballast space surface areas requiring coating protection are almost double compared to a single hull tanker of similar size. Therefore, efforts needed

for maintenance of the coated surfaces are double. A higher risk of coating breakdown can also be expected.

Damage to the ballast tank corrosion protection coatings, can occur during inspection of the space, repair of valves and welding repairs. Structural welding repairs at the boundary areas between cargo tanks and ballast tanks will damage the coatings in the double hull space. It is difficult to detect and carry out effective repairs of the damaged coatings due to the dark, wet and humid conditions inside the double hull ballast tanks.

Double hull space is complex with various structures within a narrow space. Congestion with the presence of webs and stiffeners restricts the airflow during ventilation and gas freeing operations. Problems to ventilate and gas free the double hull space make inspection and maintenance difficult and dangerous.

## **2.2. Free surface effect & angle of loll**

A ship having a negative initial metacentric height<sup>2</sup> (GM) will heel to one side, when an external force such as wave or wind acts, to an angle till the centre of buoyancy moves out to a position vertically under the centre of gravity and the capsizing moment disappears. The angle of heel at which this occurs is called angle of loll (Derrett, 1990, p.45). According to Lloyd's Register (LR), sudden lolling during cargo and ballast operations experienced on some double hull tankers is caused primarily by the occurrence of free surface effects in cargo oil and ballast water tanks ('Double-hull concerns', 2000, p.18). During loading/unloading and ballasting/deballasting, there can be free surfaces in many tanks at the same time and the effects from each tank added together will increase the risk of high reduction in GM. Some double hull tankers are

---

<sup>2</sup> Metacentric height (GM) is the distance from centre of gravity of a ship to its metacentre. Metacentre of a ship is the point at which the verticals through the centres of buoyancy at two consecutive angles of heel intersect

without longitudinal bulkheads subdividing the cargo tanks, and having tanks of much more breadth than that of single hull tankers. Derrett (1990, p.184) states that doubling the cargo or ballast tanks' breadth increases the free surface effect by eight fold. In a ship with a small initial GM, the creation of free surface can cause a virtual loss of GM. This can cause the ship to take up an angle of loll, which may be dangerous and, at the very least, undesirable (Derrett, 1990, p. 48).

As double hull tanker design generally uses double bottom and side tanks for carrying ballast water, the free surface effects associated with these tanks can be very high unless filled to the inner bottom level. Problems of critical loss of GM with the presence of free surfaces are likely to occur when the ship is close to a fully loaded condition, either nearing completion of loading or shortly after commencing discharge operation ('Double-hull concerns', 2000, p.18). The free surface effects will be extremely high in slack<sup>3</sup> double bottom tanks extending from side to side. The international convention on ballast water management, due to be introduced by IMO in 2003, might require ships to change ballast water at high seas, and the risk of free surface effects could increase further ( IMO, 2001c, p.1; IMO, 1997b, pp. 228-231).

Det Norske Veritas (DNV) (1999, pp. 1-2) has published an incident of listing of a double hull tanker during cargo operation caused by the free surface effects. A product carrier of 1996 built and 28,000 GT while loading at a terminal, listed heavily to port during shifting of ballast, and stabilised at about 16 degrees port list whilst touching the bottom. At the time of the incident, the ship was almost at even keel and the draft was about 9m. Investigations concluded that slack cargo tanks with no longitudinal bulkheads might have caused large free surface effects and the loss of initial GM, and the initial instability might have resulted in heeling the ship to the angle of loll. It was confirmed by sounding that there had been significant asymmetrical distribution of

---

<sup>3</sup> Slack tank means any tank that is not totally empty or full.



ballast before the ship listed, which also might have contributed to a high angle of loll along with the shifting of ballast water through crossover valves.

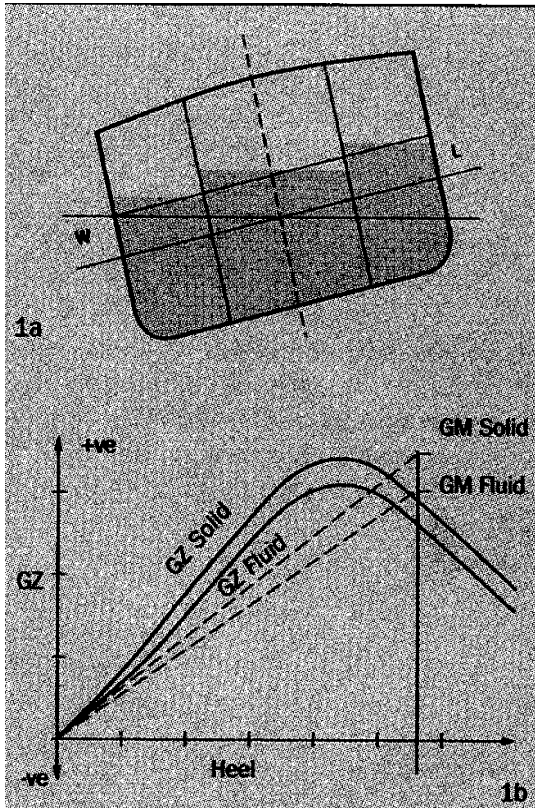

Fig.15. Diagrammatic section of a single hull tanker and its stability curve.

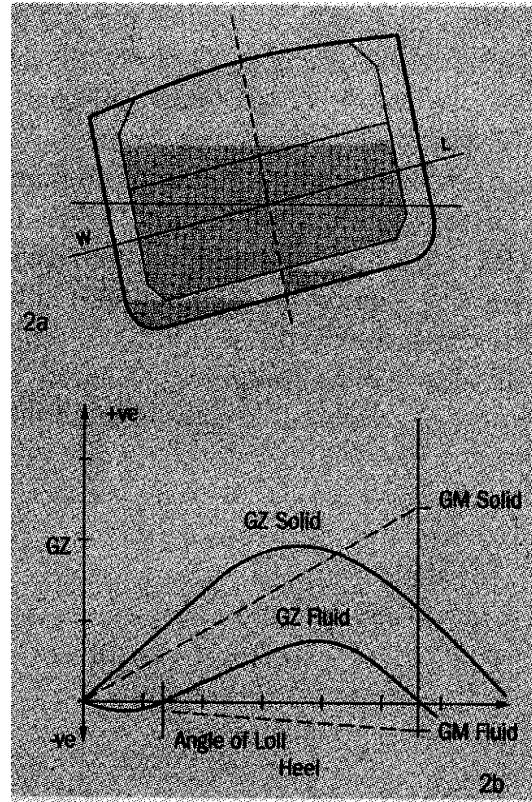

Fig. 16. Diagrammatic section of a double hull tanker and its stability curve.

(Source: The Naval Architect, 2000, June, p. 28)

The diagrammatic sections with stability righting lever curves of a single hull tanker and a double hull tanker in fig.15 and fig. 16, respectively, illustrate the essential differences in free surface effects in tankers with and without longitudinal subdivision of the cargo tanks ('Double-hull concerns', 2000, p.18). Comparing the stability curves<sup>4</sup> it can be observed that a single hull tanker with longitudinal subdivision has high initial GM,

<sup>4</sup> Stability curves, also called as GZ curves, provide information of the righting lever about an assumed center of gravity at any angle of heel and particular displacement, range of stability, angle of vanishing stability, maximum GZ, initial GM, etc. of a ship.

maximum GZ, high range of stability and good angle of vanishing stability, whereas a double hull tanker without longitudinal subdivision has all the above factors low in addition to the negative GZ causing an angle of loll.

### **2.3. Sloshing**

In the double hull tankers, partial loading of cargo in centre tanks with large smooth and plain bulkhead panels, can cause damage to bulkheads and internal fittings during rolling of the ship by sloshing. The effect of sloshing increases with increase in tank breadth and high-density cargo (DNV, 1992, p.1). An oil tanker of 56,000 GT while carrying high-density heavy fuel, suffered structural collapse of cargo pipes inside an oil tank. Some cargo tanks, including No.2 tank, were partially filled. When the vessel encountered rough weather, steam heating coils in No. 2 tank were lost. Investigations concluded that sloshing created unforeseen forces, which damaged the piping and heating coils. The report referred to the above states that in new double hull tankers with smooth centre tanks, the cargo pipe arrangement placed on the tank top would have to be protected against sloshing. Stronger and more closely spaced supports and better clamping are among the features to be considered.

## **3. Corrosion risks**

Statistics indicate that corrosion damage increases when ships are 12-15 years of age. Magelssen (2000b, p.1) states that some of the double hull tankers have corrosion problems even before reaching this age, as more areas are exposed to ballast water with low quality coating and low maintenance level. Corrosion rates are generally severe on horizontal surfaces. In oil cargo tanks, the residual water from the cargo and from water washing will lie on transverse bulkhead horizontal girders and on the inner bottom. These areas are generally left uncoated resulting in wastage of the plating, which are prominent towards the after end of the tanks due to the trim by stern (TSCF, 1995, p.19).

According to Bjarne Thygensen of Ospery Maritime Limited in London, high temperature in double hull tankers may be a contributing factor for a relatively high rate of corrosion in the upper part of a cargo tank. Other contributing factors for high corrosion rate are sulphur from inert gas, carbonic acid ( $H_2CO_3$ ) formed by combining  $CO_2$  with water, hydrogen sulphide ( $H_2S$ ) released from crude oil, and insufficient crude oil washing under deck to remove acidic deposits and corrosion products. The corrosion rate multiplies with increasing salinity, temperature, oxygen content, water velocity, and content of contaminants promoting corrosion (Magelssen, 2000b, p.7).

### **3.1. Pitting**

Pitting is a form of local corrosion within limited areas (Magelssen, 2000b, pp. 10-12). According to the Oil Companies International Marine Forum (OCIMF), excessive pitting corrosion of up to 2 mm per year was observed in the uncoated bottom plating in cargo tanks in new single and double hull tankers. In addition, indication of general corrosion up to 0.24 mm per year has been found in vapour spaces. Magelssen explains that severe pitting occurring in the bottom of cargo and ballast tanks or other horizontal surfaces may tend to merge to form a long groove or scabies of wide patches with resemblance of general corrosion. Fig. 17 shows a typical grooving corrosion in a stiffener connection. The average corrosion rate in pits and grooves can be very high. When grooves occur close to a weld between a longitudinal bulkhead and the deck, it may create a higher deformation of the stiffener resulting in an accelerated corrosion rate in the groove. This condition, at times, introduces a 'necking effect'. Fig. 18 shows a typical grooving corrosion in stiffener connection.

In 1997 the American Bureau of Shipping (ABS) reported that accelerated pitting corrosion rates were discovered in the cargo tank bottom plating of a number of

relatively new double hull crude oil tankers. This evidence suggests that corrosion rates for under deck plating in uncoated cargo tanks of double hull tankers can be two to three times the normal anticipated rate. There are several reports of severe pitting corrosion, to a depth of 3 to 4 mm, in the inner bottom plating of cargo tanks, which can be attributed to the collection of water where there has been a breakdown of natural oil film coatings formed from cargo ('Double hull concerns', 2000, p.18). Fig. 19 shows severe pitting corrosion in the bottom plate of a combined oil/water ballast tank.

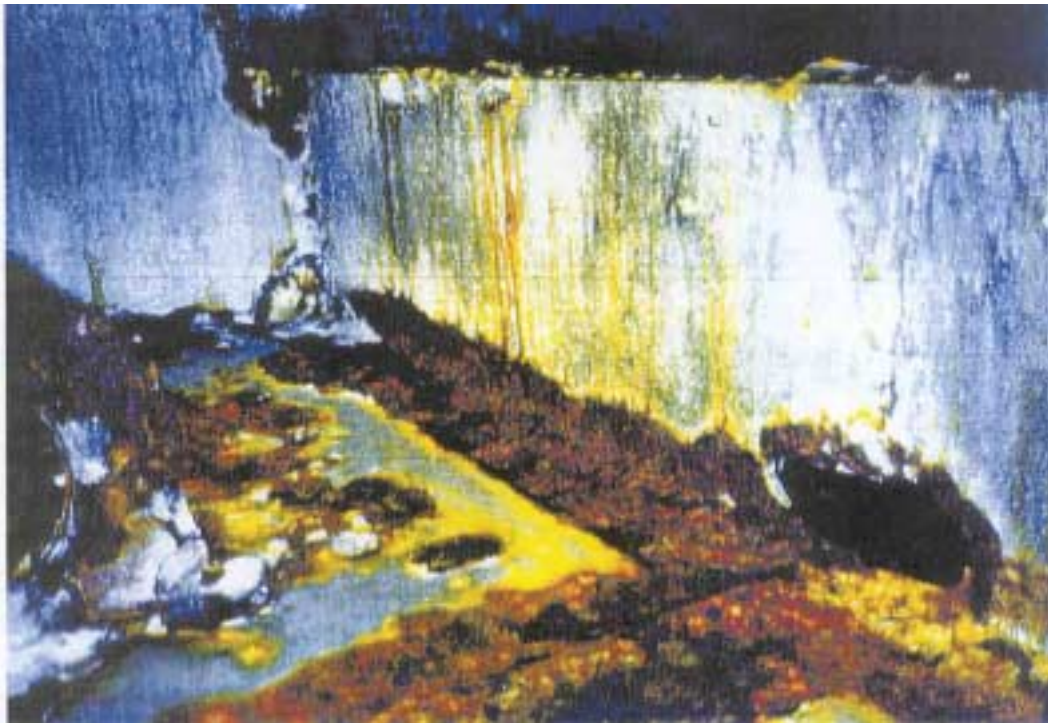

Fig. 17. Grooving corrosion in a stiffener connection (Source: DNV paper series No.2000-P008. p.11)

### **3.2. Bacterial corrosion**

Small animals eating steel may sound mythical, but it is a fact that bacteria initiates chemical processes resulting in high local corrosion rates. This is often described as 'bacterial corrosion' or 'microbial corrosion' or more correctly 'microbial influenced

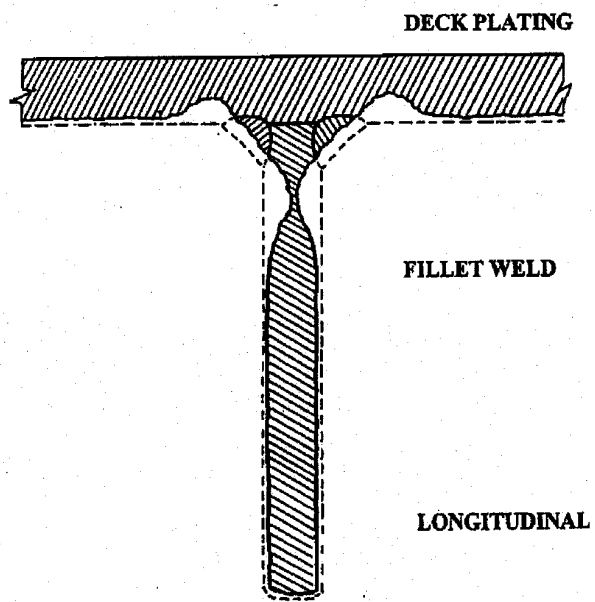

Fig. 18. Typical grooving corrosion in stiffener connection

(Source: DNV paper series No.2000-P008. p.12)



Fig. 19. Severe pitting corrosion in the bottom plate in a combined oil/water ballast tank

(Source: DNV paper series No.2000-P008. Appendix 1)

corrosion (Magelssen, 2000b, p.14). A mixture of oil, water and heat is a perfect breeding ground for bacteria. Some may require oxygen and others are anaerobic.

Microbial induced corrosion (MIC) associated with the corrosion of steel is from sulphate reducing bacteria (SRB) and sulphur oxidizing bacteria (SOB). Acid is the result of a chemical process, and consequently, pitting corrosion at an extreme rate may occur. Double hull tankers are more prone to this corrosion due to the 'thermos bottle effect'. On the loaded passage, the ballast tanks provide a buffer between the cargo and the sea, acting almost as a thermos flask. The cargoes retain their heat and bacterial growth has been shown to increase dramatically with temperature as crude oil routinely has small water content ('First fire', 2001, p.27). Fig. 20 is a typical example of bacterial corrosion. Experience indicates that bacterial corrosion occurs at a temperature range of 20°C to 50°C with a longer time duration, which explains the reason why long trade VLCC are much more exposed to this type of corrosion than other tankers on shorter runs (Magelssen, 2000b, p.14).

### **3.3. Coating**

The main parameter for a good and safe ship operable over a long period is avoidance of the situations giving rise to the need for steel renewal. To achieve this, Magelssen (2000b, pp.16-17) stresses that the factors, viz., coating and anodes, increased scantling, design, combination of the above and access are to be taken into account. Although these will increase the new building costs, the life span of the ship will be considerably increased. Fig. 21 shows pitting corrosion in the bottom plate of a ballast tank. Coating is the remedy for avoiding pitting. Fig. 22 shows protection by good coating in a pitted plate. Increased scantling and coating will reduce general corrosion. To encourage ship owners, classification societies have introduced voluntary class notations for scantling and coatings. DNV has introduced notations such as Increased Corrosion Margins (ICM) for increased scantling, COAT-1/2 for coating, etc.





Fig. 20. Bacterial corrosion (Source: DNV paper series No.2000-P008. p.15)

#### **4. Fatigue risks**

Avoiding fatigue cracks in ship structures has become a priority for safety of ships. Such cracks may result in pollution as well. The VLCCs built in the 1980's and in the beginning of the 1990's have experienced fatigue damage, which has become an industrial problem due the lack of fatigue prevention requirements in the classification society rules. Prior to 1990, Class Rules had only implicit fatigue criteria, expressed in the material factor (Dugstad, 2000, p.9).



Fig. 21. Pitting corrosion with build up of scale rust in the bottom plate of a ballast tank (Source: DNV paper series No.2000-P008. Appendix 1)



Fig. 22. Coating is the best solution when pitting occurs (Source: DNV paper series No.2000-P008. p.21)



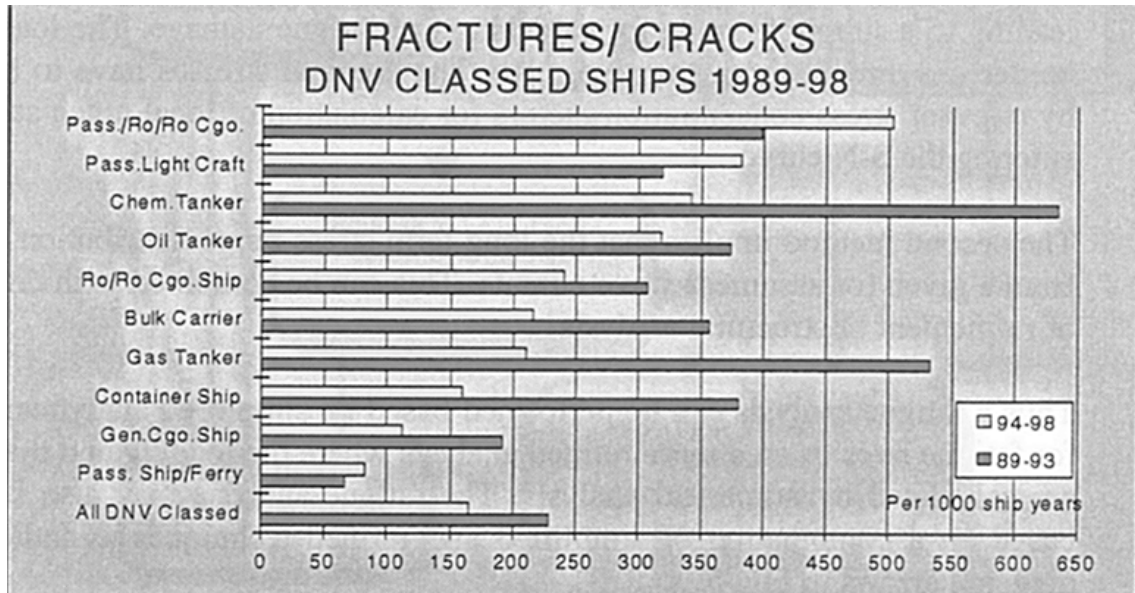

Fig. 23. Fractures/ Cracks statistics. (Source: DNV paper series No. 2000-P0004, p.5)

Hull damage may be categorised as damage due to deformation, corrosion/surface defects, and fractures/cracks. Deformation damage has been recorded for less than 10%, whereas, corrosion damage accounts for approximately 45% and fracture/crack damage for about 40%. Some damages reported are unspecified (Magelssen, 2000a, pp.1-3). Fig. 23 shows fractures/cracks in DNV classed ships during 1989-98. From this statistics, it can be observed that the share of cracks as a fraction of all hull damage for the ship types tanker for oil, bulk carrier and container carrier has increased from approximately 40% to 50%.

Fatigue life can be expressed by a simple formula:  $N = C \cdot \left[ \frac{1}{\sigma \cdot k} \right]^3$  where

N = fatigue life in years, C = constant including the environment,  $\sigma$  = nominal stress, k = stress concentration factor.

From this formula, it can be seen that fatigue life is proportional to the third power of the stress amplitude. Magelssen (2000a, pp. 12-13) & Dugstad (2000, pp. 3-8) explained factors affecting fatigue life, which includes the following.

#### **4.1. Environmental loads & corrosion**

Cyclic loading causes fatigue damage and for ships, high amplitude varying sea waves and hull girder wave bending moments are the main contributors. The most exposed areas of a ship for possible fatigue damage are side structures located between the loaded and ballast waterline, which is subjected to local dynamic sea pressure, the deck to hull girder stress, and bottom structure to a combination of hull girder stress and local sea dynamic pressure.

In a corrosive environment if the steel structure is exposed, the lifetime of the steel can be reduced by 50% due to fatigue. Hence it is important to apply a good protective coating from new building stage and maintain it during the ship's lifetime.

#### **4.2. Steel types**

Fatigue strength of a welded joint is the same for mild steel and HTS, even though yield strength for HTS is more. The lack of fatigue requirement in Class Rules prior to 1990 instigated ship owners to build ships using a large quantity of HTS in order to reduce the lightweight of the ship, increase the dead weight, and thereby reduce the building cost and increase the earning cost. The scantling was reduced too much when HTS was used, which was the cause of the majority of fatigue damage cases. Small scantling will also give high deflection and thereby a high risk for coating damage.

#### **4.3. Trading routes**

Due to different wave environments fatigue life may vary with a factor of two or more. Critical environmental areas for fatigue are the North Sea, the North Atlantic ocean and

Alaska where fatigue life will be roughly 50% when sailing continuously, compared to worldwide trade.

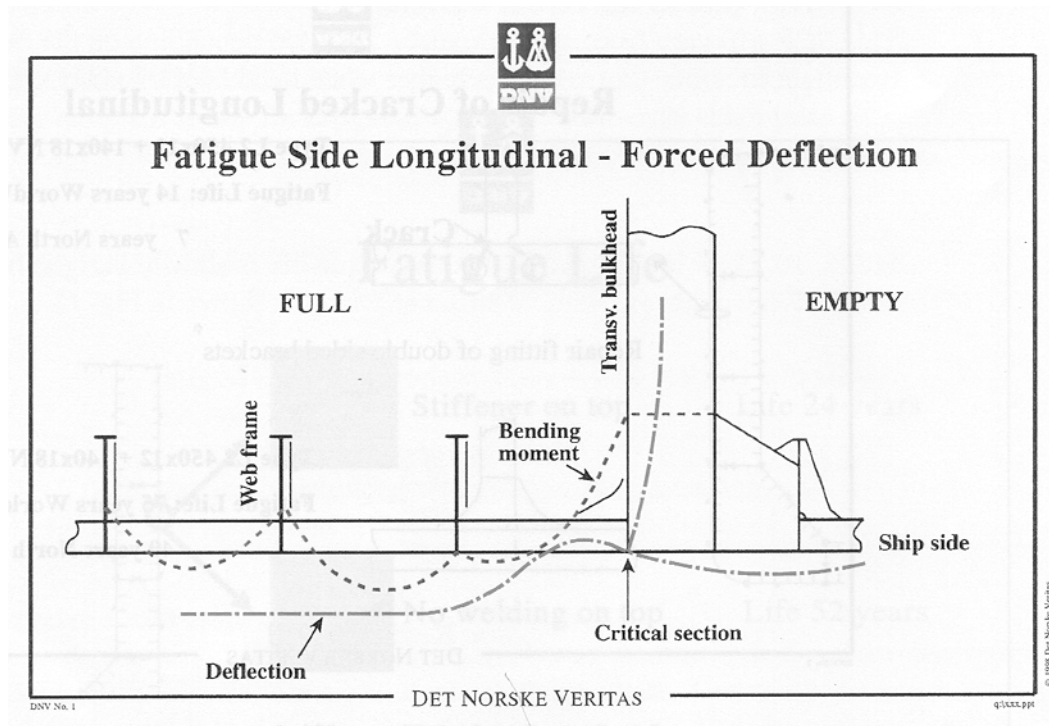

Fig. 24. Forced deflection

(Source: DNV paper series No. 2000-P0004, p.16)

#### 4.4. Relative deflection

Loads in general for ship design are based on a 20-year return period in the North-Atlantic. But when fatigue criteria were introduced, the fatigue load was based on a worldwide ship trading. Fig. 24 illustrates stresses due to forced deflection. Referring to the figure, the bending moment (BM) has a peak at the transverse bulkhead, where the BM caused by relative deflection and local bending combines to create a peak stress. The BM from relative deflection is highly dependent on the flexibility of the web frame aft of the transverse bulkhead. The fatigue life for all the longitudinals and stiffeners is

greatly influenced by the stresses due to forced deflection. As a rule of thumb the dynamic load on the side shell is taken as twice the load in the bottom.

#### **4.5. Hot spot stresses**

As fatigue life depends on the hot spot stresses ( $\sigma_k$ ) to the third power, the uncertainties in fatigue life calculated can be high. Examples are underestimated trading patterns, stress concentration factor (SCF), etc. SCF itself can be divided into three main groups, viz., due to gross geometry, weld geometry and workmanship. SCF due to gross geometry will vary from 1.5 to 6 depending on the design. Workmanship is based on approved yard standards, the influence of which is difficult to judge. SCF due to weld geometry is normally 1.5.

### **5. Structural failures in double hull tankers**

Fracture/cracks are caused mainly by stress concentrations, which occur at locations within primary structure due to specific design configurations or detailed secondary design. The Tanker Structure Co-operative Forum (TSCF) (1995, pp. 1-89) has reported many structural failures due to stress concentration in double hull tankers of various sizes, based on the information received from surveyors of classification societies. They have categorized the failures on the basis of the size and design of the tankers and demarcated the areas of stress concentration. Figs. 25 and 26 indicate the areas within the double hull tank structure of a typical large double hull tanker at which higher magnitudes of stress will occur on midship sections and transverse bulkheads, respectively.

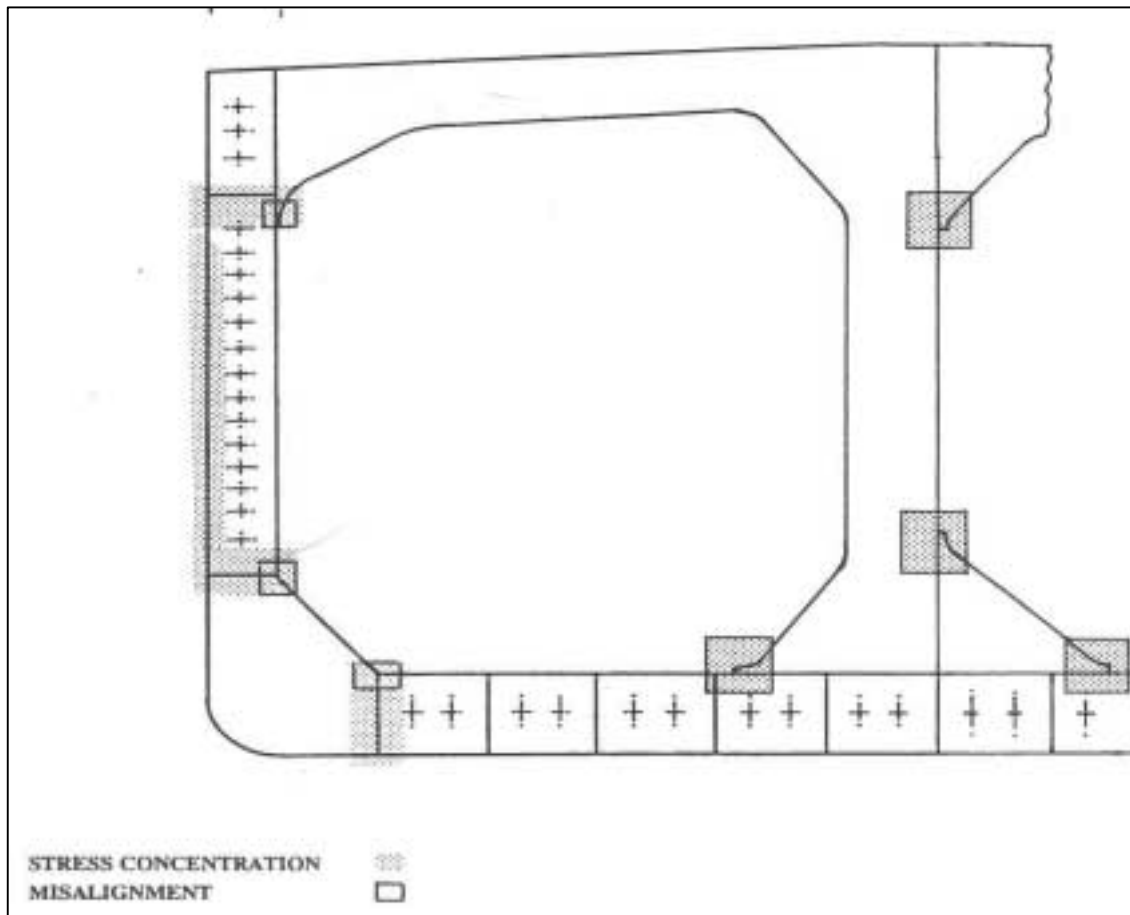

Fig. 25. Areas susceptible to stress concentration and misalignment on midship of a typical large double hull tanker (Source: Tank Structure Co-operative Forum, 1995 )

Some typical damages in the tank structure of double hull tankers, reported by TSCF along with their proposed repairs, are reproduced below with sketches. Fig. 27 shows a fracture of an inner bottom plate at the weld connection of the bilge hopper plate. According to them, contributing factors for the damage are stress concentration at juncture of hopper plate to inner bottom shell plate, insufficient welding connection and misalignment between the hopper plate, inner bottom and girder.

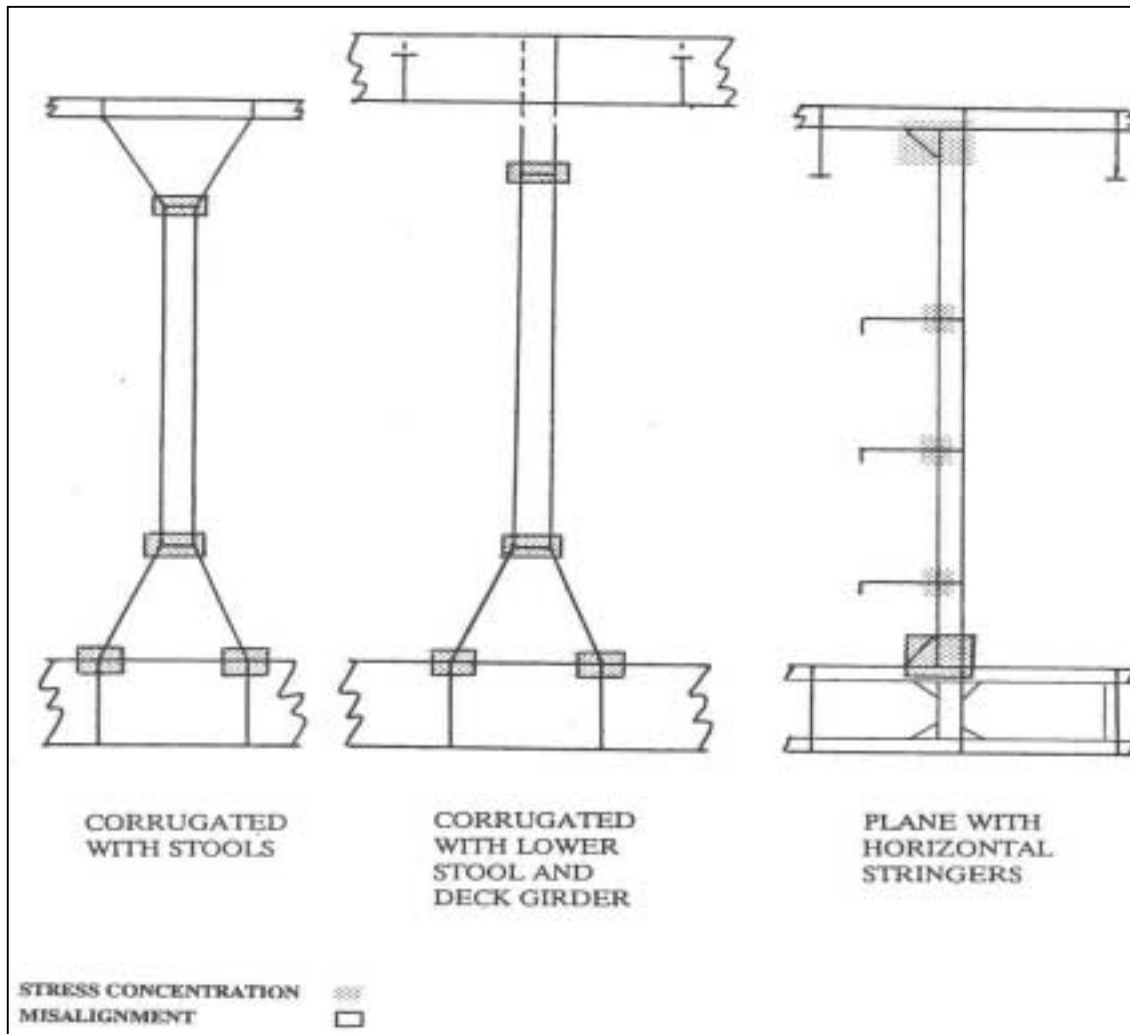

Fig. 26. Areas susceptible to stress concentration and misalignment on transverse bulkheads of a typical large double hull tanker

(Source: Tank Structure Co-operative Forum, 1995)

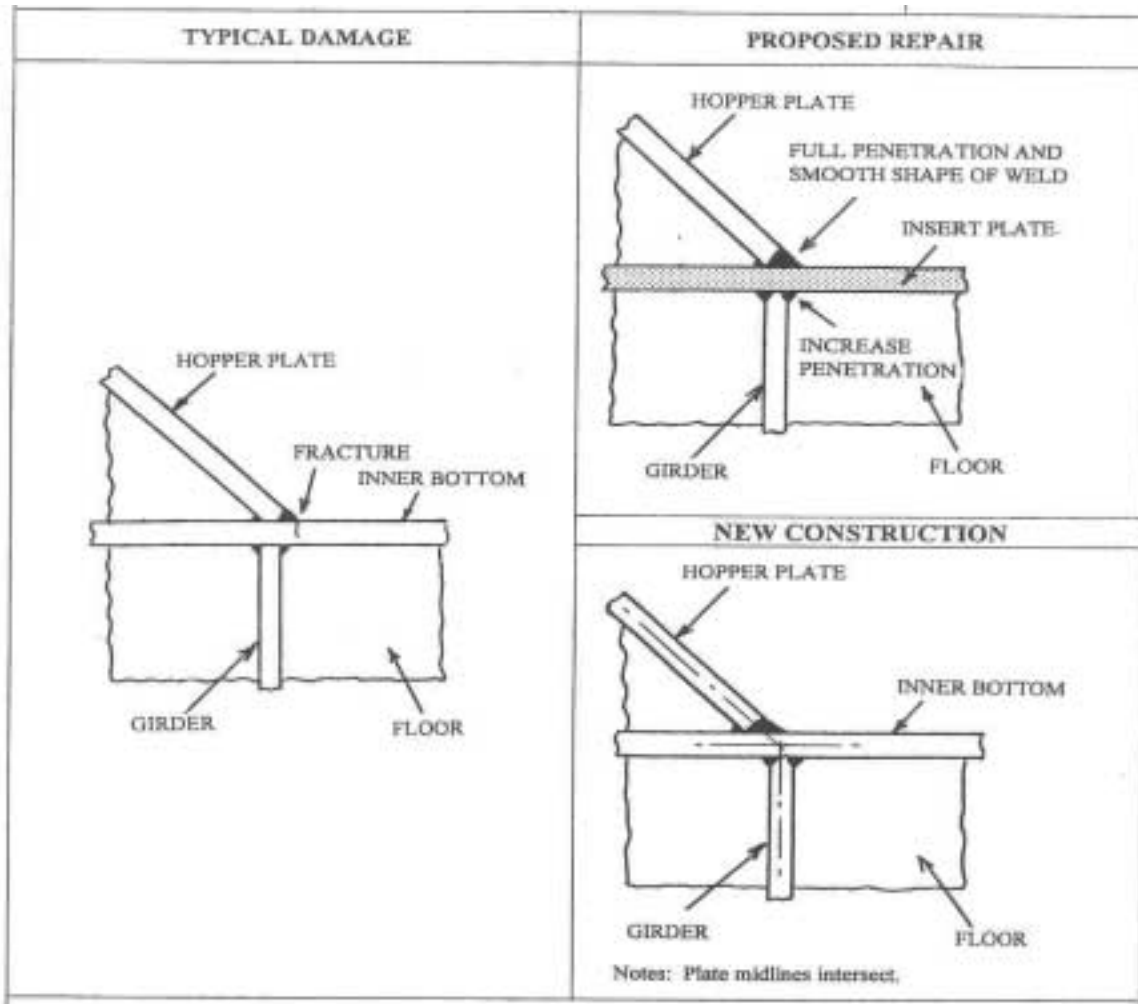

Fig. 27. Bilge hopper: Connection of hopper plate to inner bottom

(Source: Tank Structure Co-operative Forum, 1995)

Fig. 28 shows fracture at the connection of longitudinals to transverse webs in a wing ballast tank of a double hull tanker. The causes for the damage are concluded to be the asymmetrical connection of the flat bar stiffener resulting in high peak stresses at the heel of the stiffener, insufficient area of connection of the longitudinal to the web, high bending stresses in the longitudinal, additional torsion stress due to the symmetry of the

longitudinal, and stress concentrations at the square angles at heel and toe of the connections.

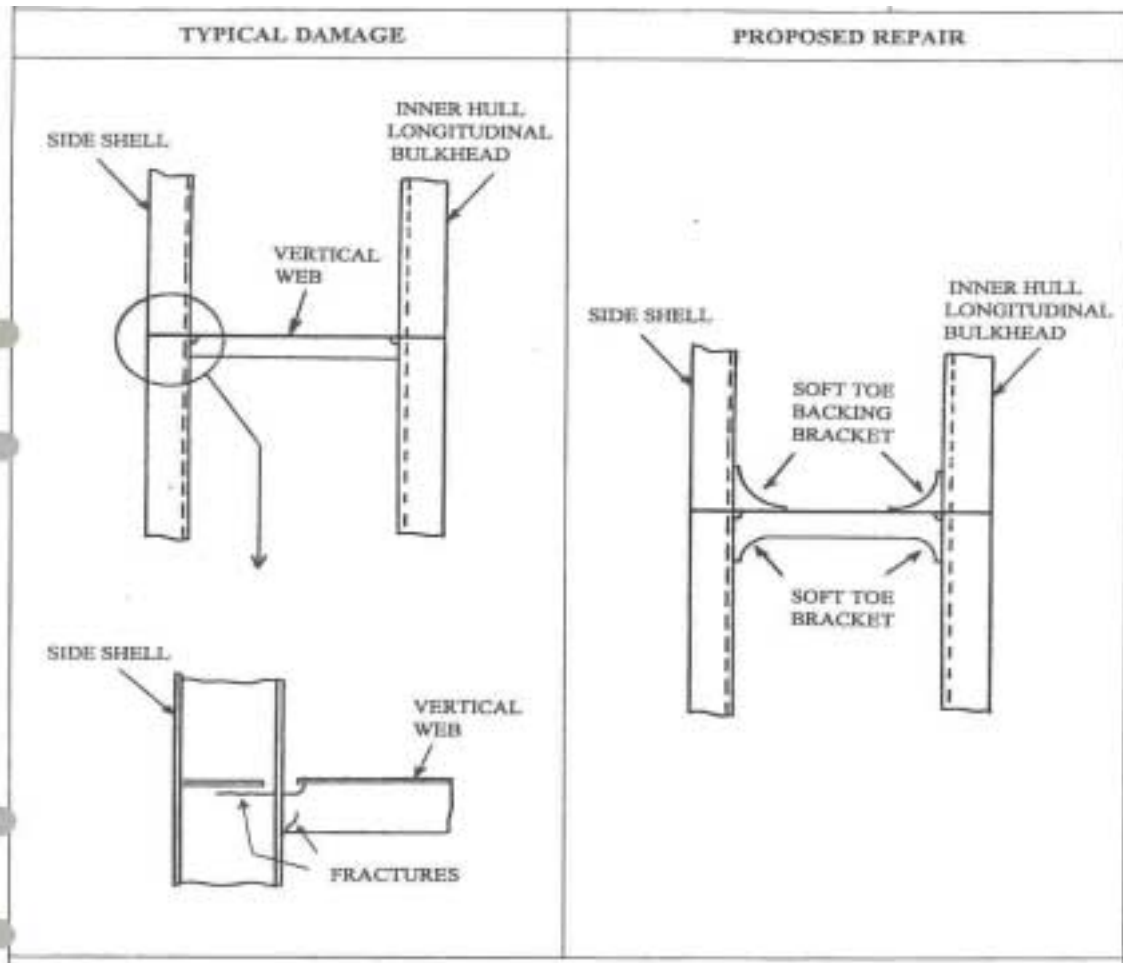

Fig. 28. Wing ballast tank: Connection of longitudinals to transverse webs

(Source: Tank Structure Co-operative Forum,1995)

Fig. 29 shows a typical fracture damage of the stiffener connection of a transverse bulkhead to the inner bottom shell and the outer bottom shell in a double bottom ballast tank. Contributing factors to the damage are considered to be the misalignment between bulkhead stiffener and inner bottom longitudinal, and high stress concentration at the points of fractures.



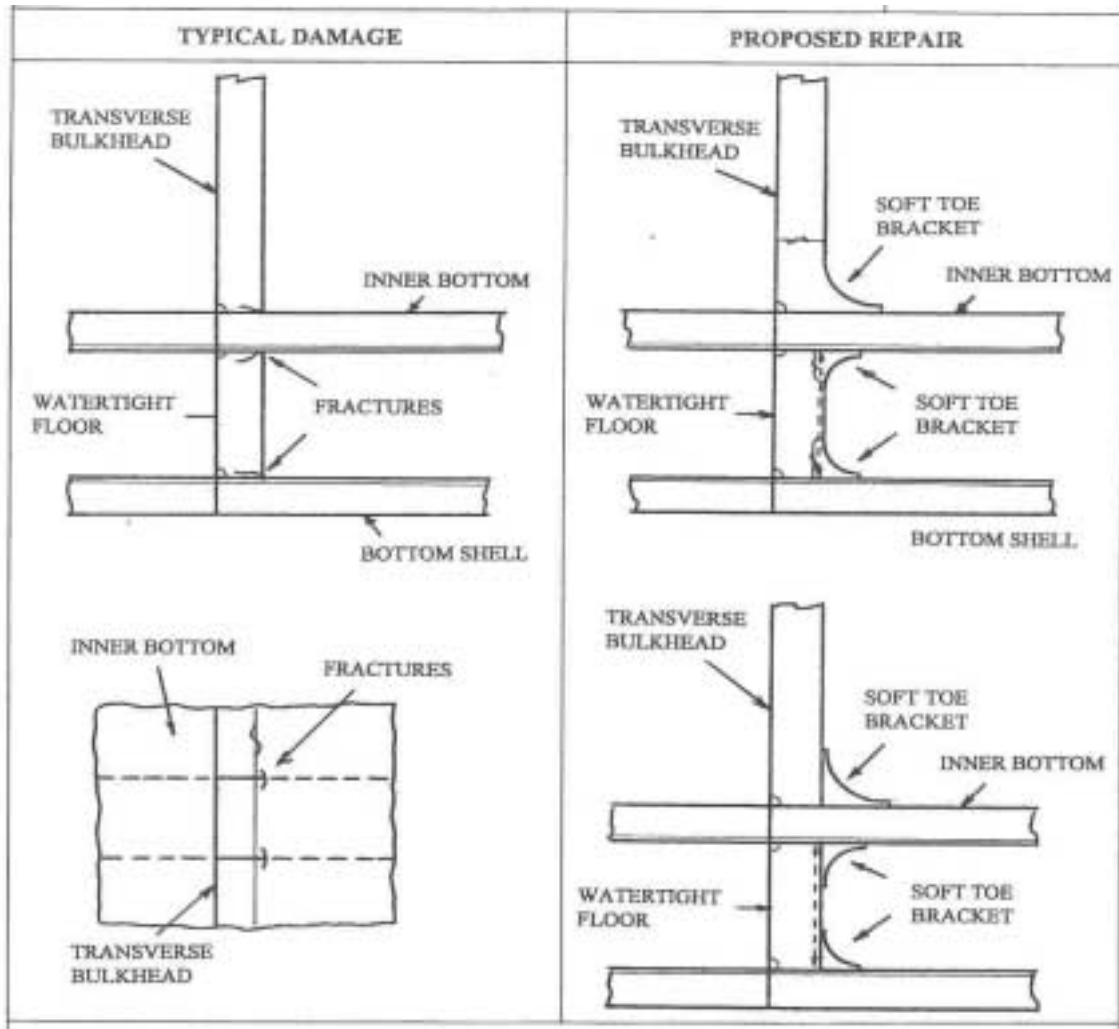

Fig. 29. Connection of transverse bulkhead: Stiffener to inner bottom and bottom shell

(Source: Tank Structure Co-operative Forum, 1995)

Fig. 30 indicates the fracture caused at the connection of a tripping bracket with the longitudinal bulkhead web in the cargo oil tank. The causes for the damage are concluded as stress concentrations at the toe bracket and high stress in the longitudinal. The modification suggested is welding soft toe brackets with longitudinal web and tripping bracket as shown in the figure, in addition to fitting an insert.

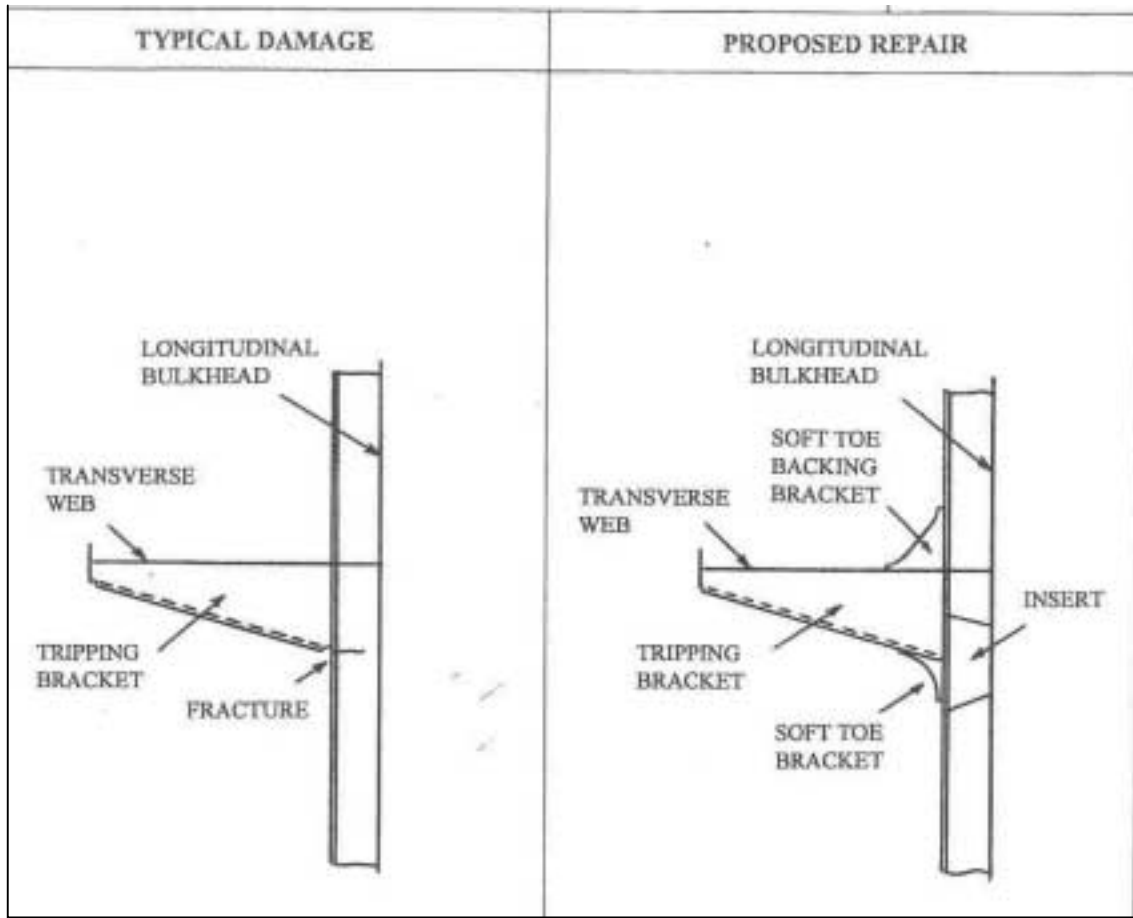

Fig. 30. Web frame in cargo tank: Tripping brackets

(Source: Tank Structure Co-operative Forum, 1995)

Fig. 31 shows the fractures at the connection of longitudinals to horizontal stringers with brackets in an oil cargo tank. The contributing factors for the damage are concluded as stress concentration due to inadequate shape of the bracket and relative deflection of adjoining transverse web against transverse bulkhead.

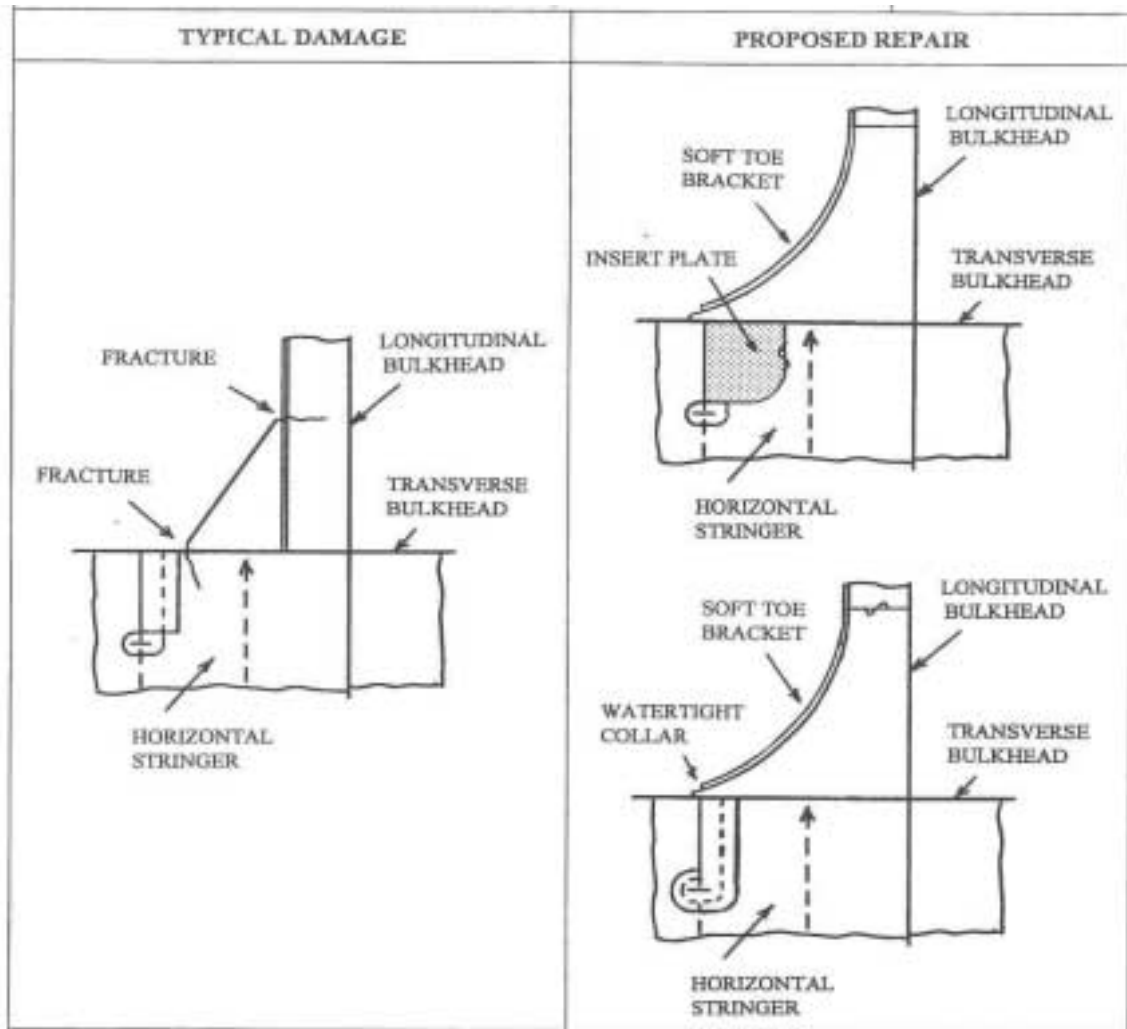

Fig. 31. Connection of longitudinals to horizontal stringers in transverse bulkhead

(Source: Tank Structure Co-operative Forum, 1995)

Fig. 32 indicates damages to the vertical corrugated transverse bulkhead with stools in a cargo tank. The factors contributing to the damage are stress concentration due to unsupported corrugation web, high through thickness stress, lamellar tearing, weld details and dimensions, misalignment, and insufficient thickness of stool side plating in relation to corrugated flange thickness. The proposed repair is bracket in line with corrugations of the bulkhead, full penetration welding of lower stool plating and vertical corrugated bulkhead with shelf plate, as shown in the figure.

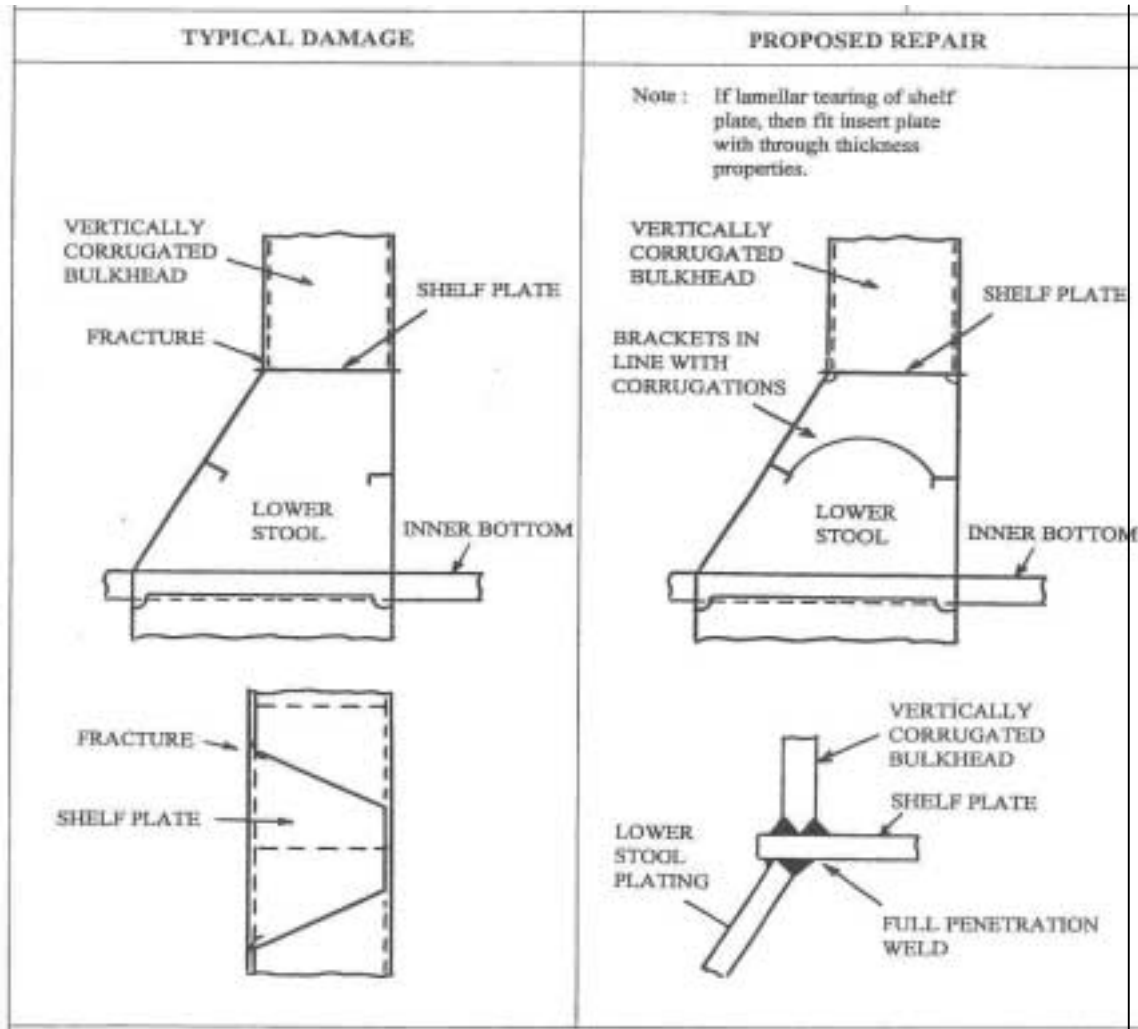

Fig. 32. Vertically corrugated transverse bulkhead stools

(Source: Tank Structure Co-operative Forum, 1995)

To summarise, due to the complexity involved in the double hull tanker structure, proper inspection, monitoring and maintenance of double hull space are difficult. Further, the surface area exposed to ballast water is much more than in single hull tankers, requiring protection by coating. Problems such as sloshing and free surface effects are also present. Cargo tanks are more prone to bacterial corrosion due to the ‘thermos bottle effect’. As the double hull spaces with sandwich panels can introduce unwanted stress concentrations, chances for fracture and cracks are more in double hull tankers.

## CHAPTER 6

### Alternatives to Double Hull Tanker

#### 1. Introduction

Accidental oil outflow from a tanker can be reduced by one of the three methods, viz., use of double hull, reduced tank size, and use of outflow prevention measures inside a tank, says Laan (1995a, p.109). The double hull concept offers protection for minor damage, but fails with regard to more serious penetrations. This is proved by a research conducted by Germanischer Lloyd (GL), which has shown definite failure of protection by double hull in case of collision at speeds exceeding 3 knots.

The logical solution to limit the oil outflow by smaller tank sizes has already been included in regulation I/24 of MARPOL 73/78, which limits the cargo tank size in large tankers to 50,000m<sup>3</sup>. Research by the National Academy of Sciences has shown that accidental oil outflow can be limited by design of tanks with half the size (NRC, 1991). But this has two disadvantages, comments Laan (1995a, p.109). Firstly, cost for small tanks is high and the maritime industry aims at larger tanks to reduce building and operational costs. Secondly, more and closer bulkheads with smaller tanks increase the chances of damage occurring at a bulkhead location, resulting in penetration of two tanks. Laan (1995a, pp.109-110) has opined that the solution by the use of outflow prevention measures inside a tank can be roughly divided into three categories, namely, hydrostatic balance for bottom damage, emergency cargo transfer for side and bottom damage and prevention of replacement outflow for side damage.

Creation of a pressure balance between cargo in the tank and water outside can prevent the oil outflow. The cargo pressure depends on the liquid column and the specific gravity<sup>1</sup>. Water pressure depends on the draught of the vessel. However, the specific gravity of cargo has to be less than that of water outside. This physical principle of hydrostatic balance is applied in mid-deck design and the vacuum system concepts.

Emergency cargo transfer from a damaged tank to an intact tank after tank penetration can reduce the oil outflow. With the ingress of seawater to the ruptured tank without losing much of the cargo, the ship's draught will increase and the higher outboard water pressure will reduce the cargo outflow. The Coulombi Egg design applies this principle.

The concept of hydrostatic balance is based on the assumption of a horizontal damage opening. In case of vertical damage, the outflow will occur until the oil is replaced by water below the highest edge of the opening. The heavier water will flow into the tank at the lower edge of the opening replacing the lighter oil flowing out at the higher edge. The rate of replacement depends on the size of opening, the specific gravity and the viscosity of cargo. The ECO-bulkhead applies this principle to prevent oil outflow.

This chapter will introduce some of the alternative design concepts to double hull, particularly Mid-deck and Coulombi Egg designs. These two concepts are approved by IMO, but not by the United States. There has not been much progress made in developing other concepts, perhaps due to the 'technological freeze' created by the tough stand taken by the United States for not approving alternative designs.

---

<sup>1</sup> The specific gravity of seawater normally falls within the range of 1.0- 1.025 tons/m<sup>3</sup> . The specific gravity of most oils is in the range 0.65-0.99 tons/m<sup>3</sup> .

## 2. MID-DECK DESIGN

Convey (U.S.) and Polviander (Finland) proposed the mid-deck tanker concept independently in the 1970's, as an alternative to double hull in reducing oil spills in grounding and collision situations (Cushing, 1994, p.11). The Mitsubishi Heavy Industries (MHI), Japan, developed the concept in order to meet the requirements of OPA 90 and IMO regulations (Tamama, 1998, p.1). The steering committee on comparative tanker designs, established by IMO, in its report states-

The mid-deck and double hull tanker designs offer equivalent protection against oil outflow when the whole range of probable groundings and collisions is considered cumulatively (IMO, 1992, p.3).



Fig. 33. General tank layout of a mid-deck tanker

(Source: IMO News, Number 1: 1992, p.4)

In March 1992, the IMO adopted mid-deck and double hull tanker designs as the international requirement for tanker new buildings ('Mid-deck design', 1993, p.21). Fig.33 shows the general tank layout of a mid-deck tanker. Based on the probabilistic oil

outflow study of alternative tanker designs by the US Coast Guard, and the model test at the David Taylor Model Basin, U.S.A., of fluid dynamics on accidental oil spillage due to grounding of mid-deck and double hull tankers, the US Coast Guard recommended double hull as the only alternative to prevent the oil outflow in grounding, the prevalent type of casualty in US waters. Consequently, the U.S.A. did not approve the mid-deck tanker design as an alternative to double hull design (Karafiath & Bell, 1993, pp.1-7).

## **2.1. Principal features**

The tank construction features a single bottom with side skins and an oil tight horizontal bulkhead. The position of the horizontal bulkhead would be below the minimum draught level at a point at which the cargo oil pressure in the lower tank becomes equal to the seawater pressure outside. The maximum specific gravity of oil likely to be loaded and inert gas pressure are taken into account. Lower tanks must not be filled more than 98% of the tank capacity ('The mid-deck supertanker', 1991, p.445).

The upper cargo tank fittings are essentially similar to conventional oil tankers except for the cargo main pipeline. Situated in the lower cargo tank are cargo oil lines, cargo vent and inert gas lines, access trunks, level gauges and fixed tank cleaning machines. A piping system as in conventional tankers for the lower tank is installed on the bottom of the tank with branch lines for both upper and lower spaces. Cargo oil vent and inert gas trunks are led from the top of the lower cargo oil tanks to upper deck and are connected to the cargo oil tank vent and inert gas main line on the upper deck. Access trunks from upper deck lead to each lower tank forward and aft and are fitted with ladders, while the level gauges measure levels through out the tank height. The access trunks can be used for various fittings and services, eliminating the need to pass through the upper tank ('The mid-deck supertanker', 1991, p.445). Fig. 34 shows the hull section of a Mitsubishi 280,000 dwt mid-deck tanker.



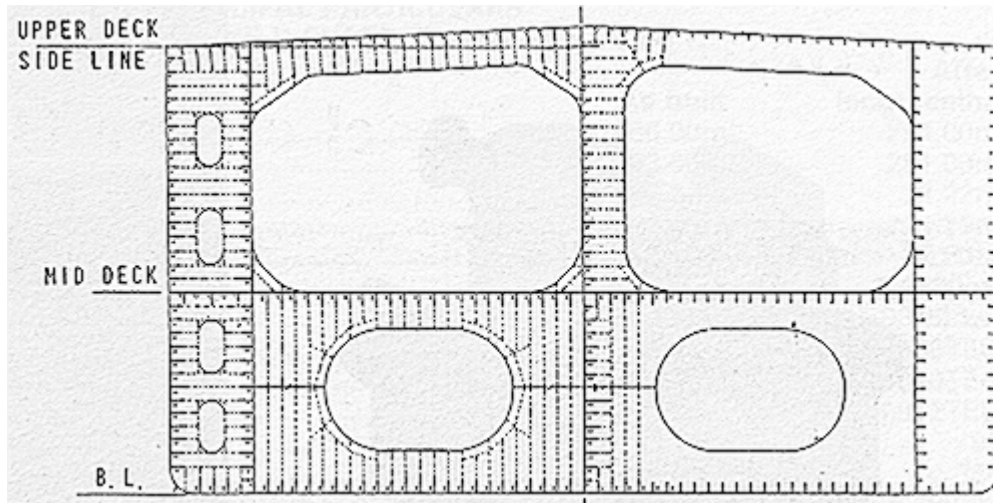

Fig. 34. Hull section for a Mitsubishi proposed 280,000 dwt mid-deck tanker.

(Source: Naval Architect, 1991 October, p. 445)

## 2.2. Oil outflow containment

By splitting the cargo tanks into upper and lower spaces with a strategically located horizontal mid-deck, the pressure of oil at the bottom plating does not exceed the outside seawater pressure. When grounded, the high pressure of the seawater pushes it into the bottom of the ruptured lower tank, forcing the cargo oil upwards and forming a seawater layer under the oil. As the lower tanks will be operated at 98% loaded condition or less which will allow the forming of a layer of seawater below the cargo in grounding, the effectiveness of hydrostatic balance is enhanced. With the increase in draught by the inflow of seawater, and the water layer formed below the oil and above the rupture will greatly reduce the oil outflow from the vessel ('Mid-deck design', 1993, p.21).

According to Nobuhara ('Mid-deck design', 1993, p.21), occurrence of a secondary oil outflow by loss of hydrostatic balance is possible. The cause can be wave-induced ship motion, relative water flow when the ship moves through the water after damage, tidal current when the ship is aground, or change in water level caused by tidal drop. However, large model tests using oil, carried out in Japan and USA under the

supervision of an IMO Steering Committee, quantified that the secondary oil outflow and initial exchange loss represented only 1-2% of the cargo tank capacity. To provide a deep layer of seawater in the damaged tank bottom, an emergency suction line can be connected to the ballast line allowing the emergency transfer of oil into the ballast water tanks. Fig. 35 shows such an arrangement on the design of the MHI.

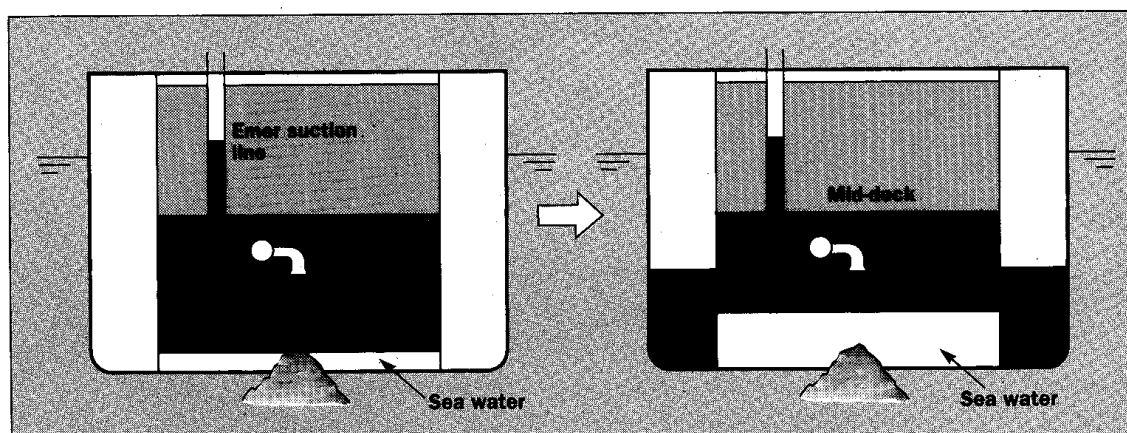

Fig. 35. An emergency suction line below the mid-deck on MHI's design.

(Source: The Motor Ship, 1993 April, p. 21)

The upper and lower cargo tanks can have free surfaces; but with no double bottom, the centre of gravity of the cargo oil is lower, states Nobuhara. This compensates for the free surface effects. Thus the mid-deck tanker has good stability. The mid-deck tanker would be able to meet the damage stability criteria even in extreme cases of upper tanks being fully loaded and the lower tanks being empty ('Mid-deck design', 1993, p.21).

### 2.3. Safety aspects

The space width between the double sides that form water ballast tanks in MHI's mid-deck tanker design is twice that of a double hull tanker, which provides extra protection to the cargo tanks in the event of collision. The extra width also facilitates easier

inspection and maintenance of the space ('Mid-deck design', 1993, p.22). As there is no double bottom (DB) in a mid-deck tanker, risk of oil or cargo vapour leak into the DB space that can lead to an explosion is absent. Further, there are no difficulties associated in re-floating the vessel for loss of buoyancy in case of grounding ('Mid-deck design', 1993, p.22). In the opinion of this writer, with the wide side tanks the chances for developing problems as experienced in side tanks of double hull tankers with sandwich construction, are less. For example, the stress concentration and subsequent stress induced fatigue could result in cracks in the inner shell structure of a double hull tanker.

The coating protection required in ballast spaces in a mid-deck tanker would be 1.5 times that of a single skin tanker, whereas a double hull tanker would have an area 2.5 times greater ('The mid-deck supertanker, 1991, p.445). As seen in chapter 4, the reduced area exposed to damage during inspection and maintenance and the wide space reduce the probability of coating damage. So the risk of corrosion caused by coating damage is reduced in the mid-deck tanker as compared to the double hull.

#### **2.4. Collision & Grounding**

At the request of the IMO Steering Committee on the comparative study on oil tanker design, Lloyd's Register (LR) analysed<sup>2</sup> the predicted oil outflow in the case of collision and grounding of double hull tankers and mid-deck designs. The content of analysis is as follows: ('Mid-deck design', 1993, pp. 22-24).

The normalised oil outflow results derived from the collision methodology show that the expected oil outflow is less from mid-deck design compared with the double hull configurations. The increased width of the ballast wing tanks in mid-deck designs

---

<sup>2</sup> The oil outflow methodology and results are published by Dr. David Aldwinckle, Principal Surveyor, Safety Technology Department, Lloyd's Register, in February 1992.

provides considerable collision protection to the cargo tanks, as reflected in the report. The vertical extent of a collision breach was assumed from the keel upward without limit, and the oil outflow reduction provided by the horizontal bulkhead were not considered. Therefore, in collisions involving only breach of upper cargo tanks, the oil outflow would be further reduced from the expected quantity.

The normalised oil outflow results derived from the grounding methodology show that the mid-deck tanker designs experienced the least expected oil outflow at grounded draughts of 0 m, 2 m, and 6 m. But with a breached bottom plating, tidal fall is likely to increase oil outflow even though the designs are to retain cargo in the lower cargo tanks. With positioning of mid-deck at low or high to avoid penetration on grounding, the oil outflow performance is not significantly affected. Double hull tankers tend to retain the oil remaining in the tank following grounding and a draught reduction by 2 m. But, the oil outflow increases significantly with a draught reduction of 6 m, as the seawater cushion is lost from the double bottom.

In the MHI's mid-deck tanker design, up to a maximum 70% of HTS will be used in construction of the hull, especially in the deck and bottom structures, enabling the vessel to carry more cargo for the same dimensions as of a mild steel ship. Also, there is more fuel economy ('Mitsubishi's mid-deck', 1992, p.481). The cargo discharge time is considered to be similar to conventional tankers ('The mid-deck supertanker', 1991, p.445). For tank cleaning, deck mounted guns can be fitted as on conventional tankers. In the bottom spaces, guns can be mounted on the tank top. Two large trunks for inlet and exhaust can supply fresh air or inert gas to both upper and lower tanks and model tests have shown satisfactory results ('Mitsubishi's mid-deck', 1992, p.481). Preliminary estimates for MHI mid-deck designs indicate that for a VLCC the building cost will be 1-2% lower than for a double hull design ('The mid-deck supertanker, 1991, p.445).

The expected oil outflow calculated by LR from mid-deck design in case of a collision or grounding was generally lower than that from corresponding double hull design. However, it also depends on the specific cargo tank arrangements in both designs as confirmed by analysis. This gives scope for optimising the designs with a view to minimise the expected oil outflow ('Mid-deck design', 1993, p.24). However, the actual performance during operation of mid-deck tankers is not known to the shipping world due to the absence of such tankers in operation.

### **3. COULOMBI EGG DESIGN**

Following a meeting held in London on 9th April 1997, the IMO has accepted the concept of the Swedish sponsored Coulombi Egg design as an alternative to double hull tankers in accordance with regulation I/13F(5), MARPOL 73/78 ('Coulombi Egg gains', 1997). The design was approved by the MEPC in September 1997. A naval architect based in France, Anders Björkman has invented and developed this design. The concept is based on the principle that oil is lighter than water ('Breaking with', 1996, p.38).

#### **3.1. Basic features**

The Coulombi Egg tanker design follows the single hull technology as much as possible and introduces some new features developed over the past few years. The bow and stern designs are similar to the conventional single hull tanker with forepeak tank, after peak tank, collision bulkhead, pump room, and engine room. The basic difference is in the cargo and ballast space designs. The general layout and mid-ship cross section of a Coulombi Egg tanker are shown in fig. 36 and fig. 37 respectively.

At the mid-ship, it is a single hull design with a stepped mid-deck from side to side. The mid-deck slopes at each side and is connected to the longitudinal cofferdams at each of

the hull sides ending at  $0.25D$  above the base line. The wing tank bulkheads are at a point one-fifth of the breadth ( $B/5$ ) from the shipside. A mid-deck oil tight horizontal bulkhead<sup>3</sup> divides all the centre tanks and the wing tanks in the respective tanks. The horizontal bulkhead dividing the centre tanks into upper and lower tanks is located at a height not more than 55% of the depth ( $0.55D$ ) above the keel. The centre tanks may be either single or divided into port and starboard tanks depending upon the size of the ship. Unlike the centre tanks, the wing tanks are divided into upper and lower tanks at a height lower than that of the bottom of the upper centre tanks by a bulkhead in the following manner. The horizontal bulkhead begins from the inner longitudinal bulkhead at a height  $0.45D$  and extends to the side till it slopes downward at an angle of 45 degrees to meet the cofferdam bulkheads at its upper inward corner situated at a height of  $0.35D$  from the base line. The cofferdams are located on both sides of the ship in the cargo area at a height extending from  $0.25D$  to  $0.35D$  with a minimum breadth  $B/40$  (Björkman, 1997a, pp. 1-3).

The upper wing tanks are segregated ballast tanks. More than 80% of the cargo is carried in the centre tanks, which are inboard of  $B/5$  from both sides and the balance of the cargo is in the lower wing tanks. Slop tanks are located in the aftermost upper cargo tanks. No cargo tank has a length greater than 20% of the ship length. That means, for any size of ship the minimum number of centre tanks lower and upper, wing tanks lower and upper on port and starboard sides will be at least four numbers each ('Breaking,' 1996, p. 38).

### **3.2. Transverse web frames & transverse bulkheads**

Fig. 38 shows a typical transverse web frame of a 280,000 dwt Coulombi Egg design. The advantages claimed in this design are easy for fabrication as the construction is in mild steel and easy for cleaning of lower centre tanks. The side webs are supported by

---

<sup>3</sup> Horizontal bulkhead means the deck between the upper and lower tanks.

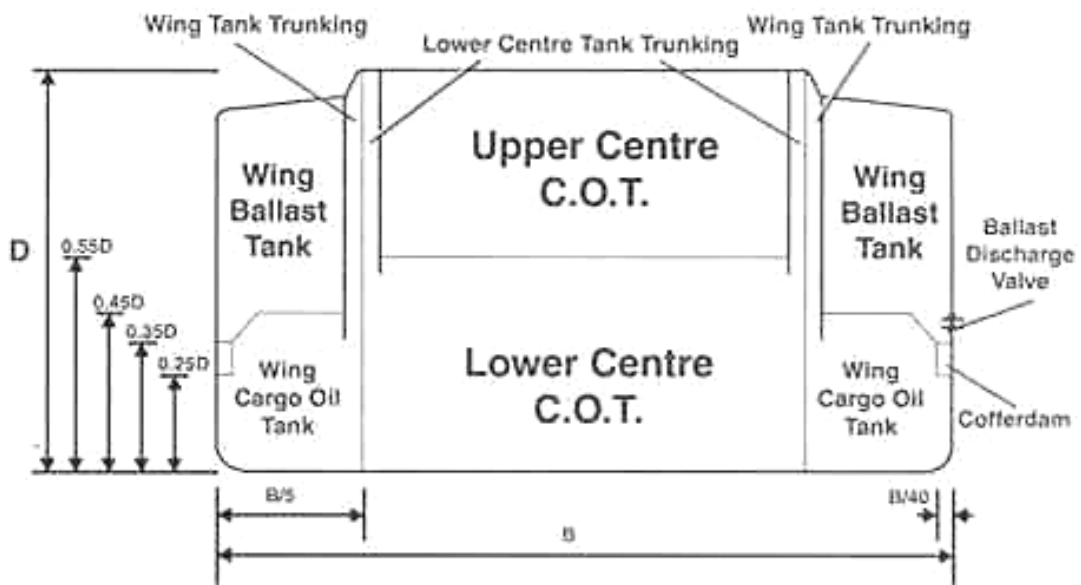

Fig. 36. General layout of a Coulombi Egg tanker

(Source: Fairplay, 1996, May 9, p.38)

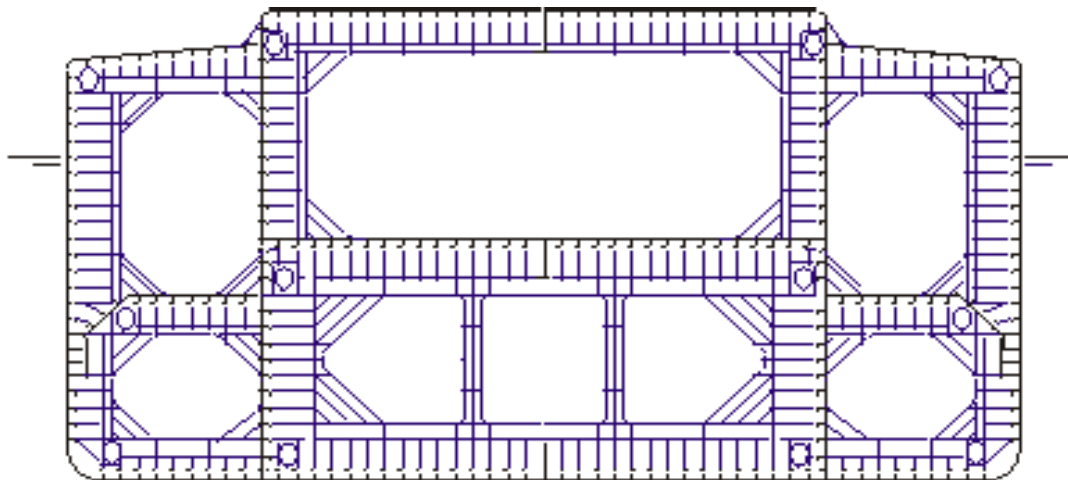

Fig. 37. Midship section of a Coulombi Egg design.

(Source: The Naval Architect, 1993, May, p.297)

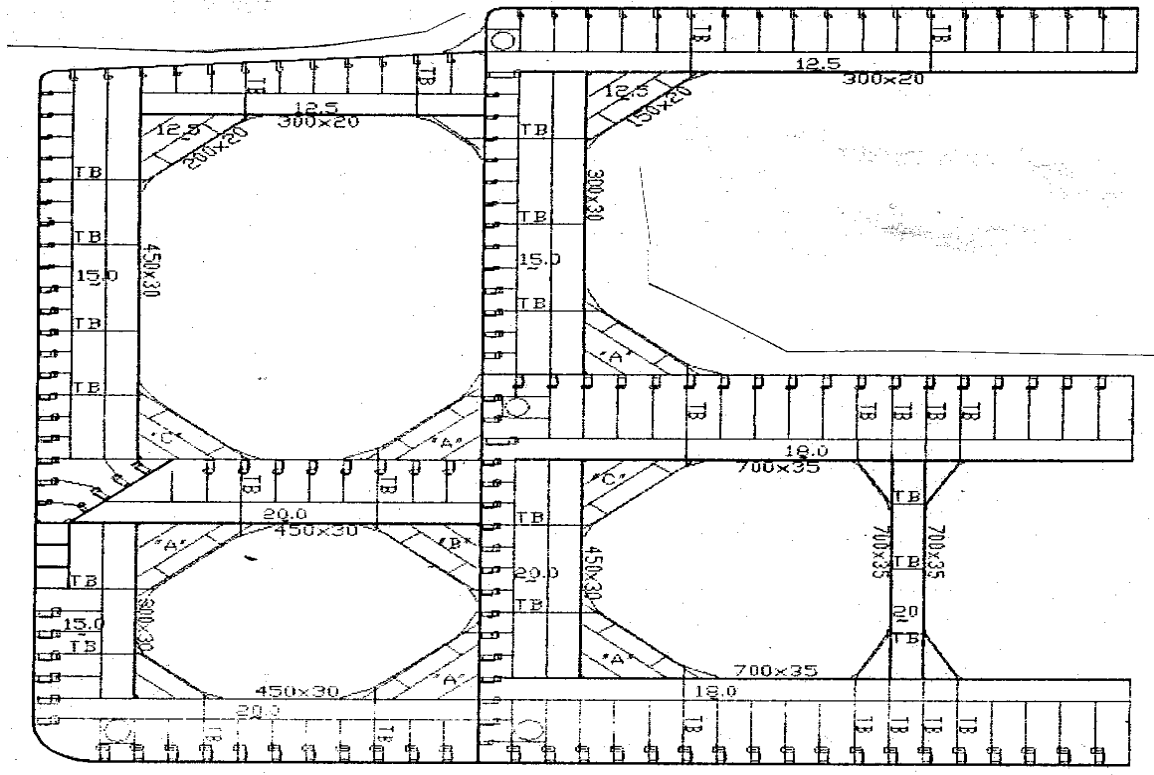

Fig. 38. Transverse web frame construction for a 280,000 dwt Coulombi Egg design

(Source: The Naval Architect, 1993, June, p.295)

mid-deck to reduce deflections. The centre bottom and mid deck webs are connected by two vertical struts to distribute the internal and external loads between the webs. The corner brackets are mostly of standard design. Transverse bulkheads are supported by vertical webs and are horizontally stiffened. The vertical webs are supported by bottom shell, mid deck and main deck (Björkman, 1993, p.295).

### 3.3. Fabrication

The tank body can be fabricated in different blocks and assembled at the building yard. Fig. 39 shows a proposed split up of a half mid ship section into four blocks during



fabrication. Each block consists of flat plate panels with stiffeners and rectangular open webs adapted for fully automatic fabrication and welding in panel and web lines. Corner brackets are fabricated in separate lines. Welding and dimensional control along the full width mid deck is easy. Application of coating to the ballast tanks can be carried out during block assembly or even after assembly (Björkman, 1993, p.295).

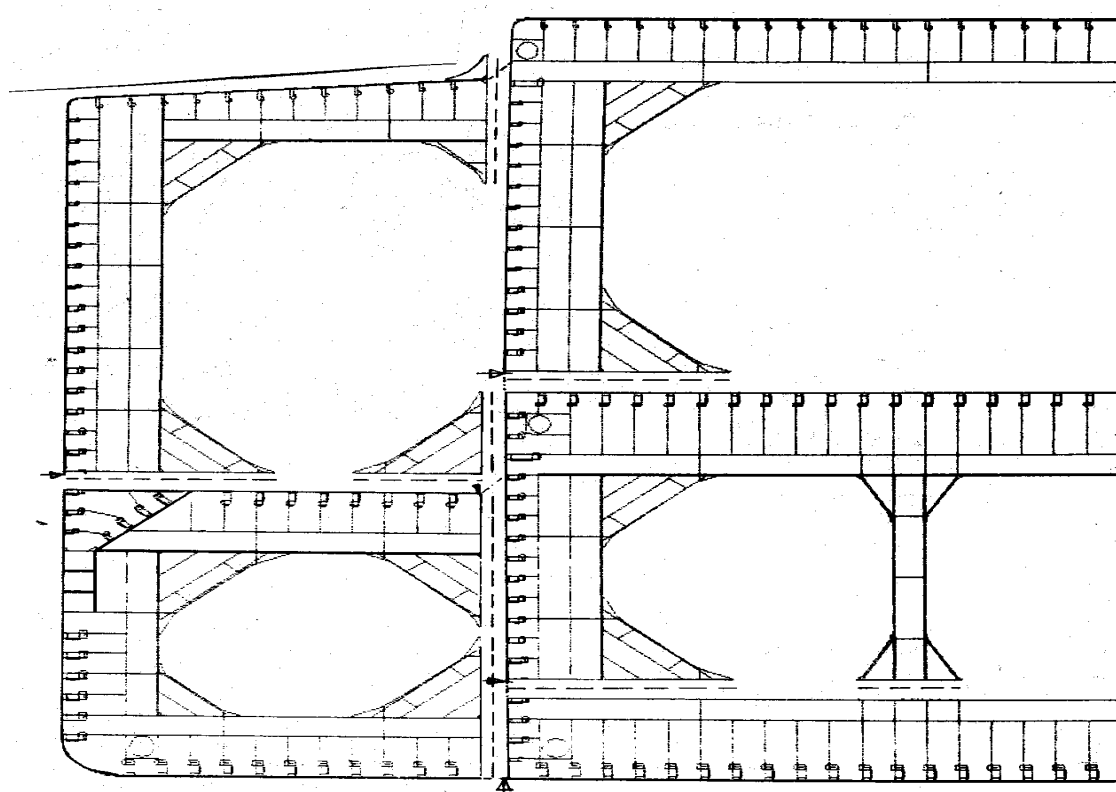

Fig. 39. A 280,000 dwt Coulombi Egg tanker proposal for building block fabrication

(Source: The Naval Architect, 1993, June, p.297)

### 3.4. Grounding & collision

The Coulombi Egg design provides protection against grounding and collision. In case of grounding and puncture of bottom shell, effective protection against cargo oil outflow is provided by the side-to-side mid-deck. Upper wing tanks, which are ballast tanks, act

as emergency receivers for cargo if the lower cargo tanks are punctured. In case of collision, the deep penetration of the side is frequently seen to occur above the water line. As the Coulombi Egg tanker has B/5 wide wing tanks, it can absorb a substantial amount of collision energy and hence provide more structural protection. The ballast tanks and cofferdams operate as crush zones absorbing the impact while preventing any breach of cargo tanks. The partial transverse bulkhead subdividing each lower wing tank at its half-length is welded to the mid deck bulkhead and extends down to the height of bottom edge of cofferdam. These bulkheads restrict the outflow of oil from the tanks trapping it in the deckhouse space<sup>4</sup> as shown in Fig. 40 ('Breaking,' 1996, pp. 38-39).

For safety measures against leak of oil cargo, automatic cargo transfer is envisaged in the event of breached shell plates below the water level. A system of piping and trunk connections between different tanks is used for this purpose. All lower wing tanks have access trunks at their forward and after ends. A pipeline with a non-return valve is connected to each access trunk at a level slightly above the upper level of the tank and leads across to the bottom of the upper wing tank on the opposite side. When the tank is breached by grounding or collision in a loaded vessel with cargo in the lower wing tank, there will be an initial inflow of water under hydrostatic pressure due to the draught that will raise the oil up into the access trunks. The force created by pressure due to the oil head in the access trunk will open the non-return valve in the crossover pipeline and lead cargo oil into the upper wing tank on the opposite side. Fig. 41 illustrates the process. As water displaces the cargo oil from the punctured tank to the ballast tank on the opposite side, a list is produced causing the grounded side to come up and assists in re-floating the vessel, in addition to avoiding oil spill. For lower centre tanks, the protection arrangement is similar to that of lower wing tanks, except that the pipelines from the access trunks with non-return valves are connected to both the upper wing tanks, as

---

<sup>4</sup> The deckhouse space is the space entrapped by the partial bulkhead below the mid deck bulkhead and extends down to the bottom edge of cofferdam.

illustrated in Fig. 42 ('Breaking with', 1996, p.39). The system works well as long as the inflow of water caused by the damage in the side tank does not exceed the capacity of evacuation system (Björkman, 1997b, pp. 1-3).

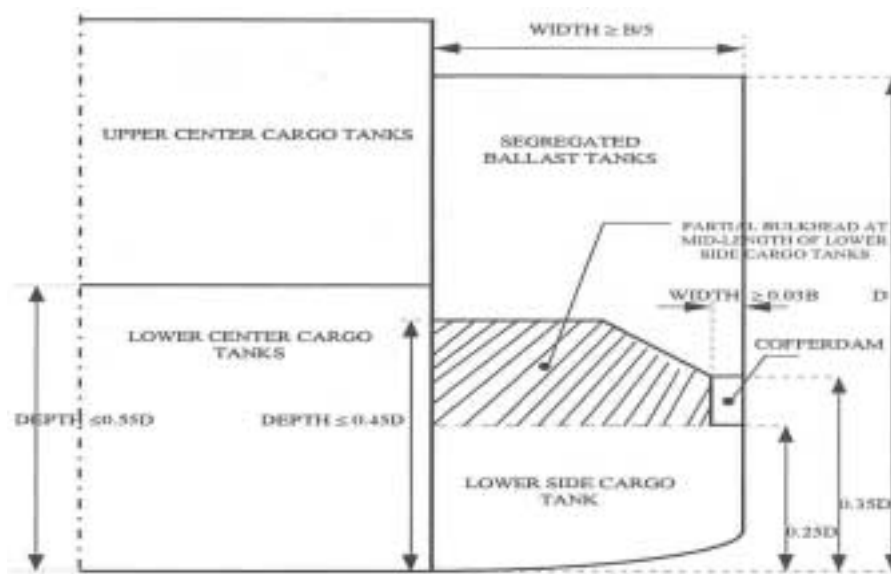

Fig. 40 Midship section showing the partial bulkhead

(Source: IMO, MEPC/ Circ.336)

Even though collision is more likely than grounding, collision between tankers as happened in the case of the Venpet/ Veniol disaster off the coast of South Africa is rare. Most tanker collisions involve cargo vessels either with head-on collision causing damage to the bow or contact at the sides damaging the upper hull. The bow of a Coulombi Egg tanker is specially strengthened with forecastle and forepeak tank. The upper ballast wing tanks provide similar protection to the upper hull sides. In the conventional and double hull tankers collision damage to the upper hull is likely to cause

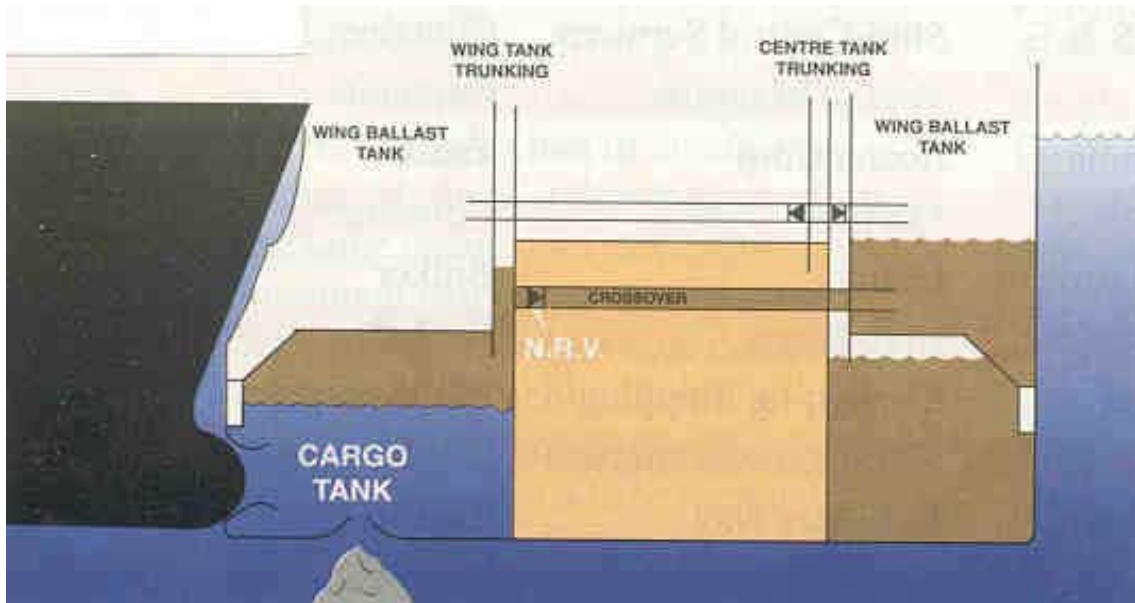

Fig. 41. Breach of wing cargo tank allows inflow of water under hydrostatic pressure forcing oil via the crossover to the ballast tank (Source: Fairplay, 1996, May 9, p.39)

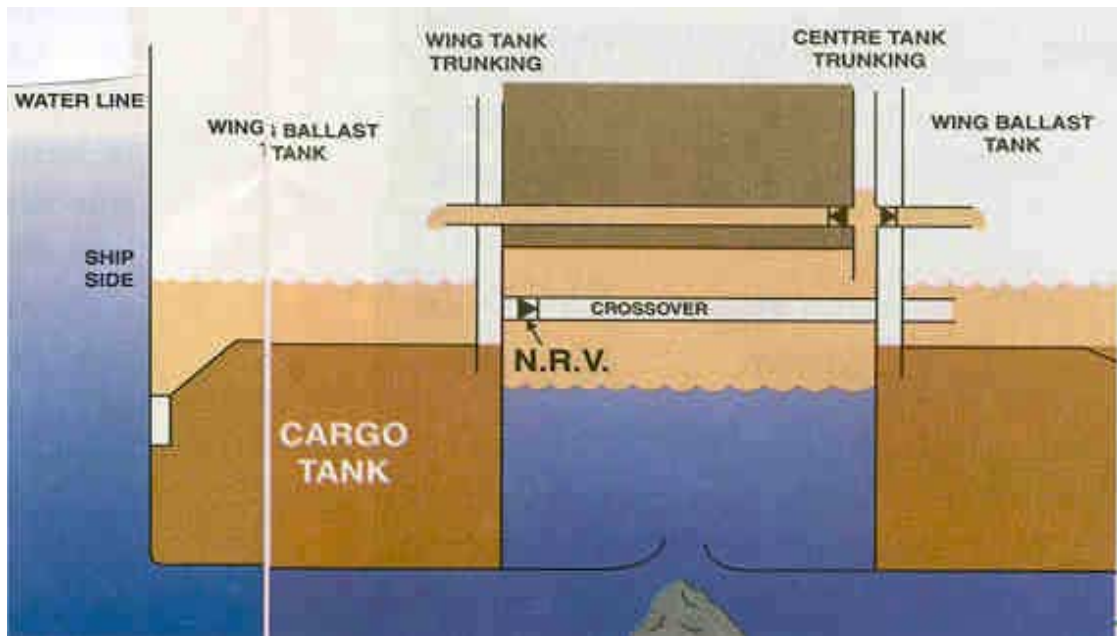

Fig. 42. Breach of lower centre tank forces oil to both wing tanks.

(Source: Fairplay, 1996, May 9, p.39)

an oil spill followed by an explosion and fire, as it happened in the *Agrip*, *Abruzzo*, *British Trent*, *Haven*, *Massia*, and *Independentia* incidents. Salvage operations and prevention of further pollution are extremely difficult in such accidents in addition to the loss of life of crew ('Breaking with', 1996, p. 39).

Based on the detailed theoretical and computer modelling studies conducted, it is seen that the Coulombi Egg system will work in a range of tidal conditions at different draughts. With significant bottom damage, oil outflow is often prevented or minimised even in severe tidal conditions (Björkman, 1997b, pp.1-3). Another benefit claimed is that the amount of oil spill, if any, caused by an accident will be 3 to 4 times less compared to the double hull design ('Coulombi Egg Tanker', 2000, p.1).

### **3.5. Cracks & fractures**

Cracks and fractures do occur in tanker structure but they should not occur in oil and ballast boundary structure causing oil leak into ballast spaces. In Coulombi Egg tankers, with the horizontal bulkhead between the upper deck and bottom plating in each transverse section in the cargo deck area, the upper part of the longitudinal bulkhead is minimally stressed. Further, the cargo areas are not subjected to the severe threat of corrosion and the chances of cracks and fractures are less, when compared to double hull design. Any such occurrence can be easily detected, as the leaked oil will be collected at the outboard corner of the ballast tank (Björkman, 1993, pp. 295-296).

### **3.6. Ballasting & cargo handling**

The ballast tanks are not fitted with any pipe connections. These tanks are filled through the deck lines from the top and discharged directly through the overboard valves fitted at the bottom of the tanks. ('Breaking with', 1996, p. 39).

Coulombi Egg tanker is suitable for handling three grades of cargo by using the free flow method. Cargo suction pipelines can be avoided and the three pumps can take direct suction from the aftermost tanks. Submerged machines are to be used for tank cleaning of the lower tanks. The structural arrangement in the lower centre tank facilitates tank cleaning with a lesser number of machines for 100% coverage. Intact stability and damage stability criteria have been analysed for various conditions and found to be satisfactory (Björkman, 1993, p.296).

### **3.7. Construction cost**

According to Björkman (1993, p. 297), even though approximately 10% more steel is used in the tank body construction the initial cost will not be 4 to 5% more than that of a single hull tanker. Moreover, with the basic form of a conventional tanker the structure is simpler for construction as compared to a double hull vessel. The additional horizontal bulkheads increase the overall strength of the vessel.

### **3.8. Observations**

Even though the concept of the Coulombi Egg design has been approved by the IMO, the reliability of the system is yet to be proved, as the maritime industry does not have experience in operating such ships. A leak in any of the non-return valves in the pipelines connecting wing ballast tanks with lower cargo tanks, provided for emergency cargo transfer, can find entry of ballast water from the ballast tanks to lower cargo tanks when the ship is in ballast condition. In loaded condition the lower cargo tank atmosphere can find its way to the ballast tank through the leaking valve and make the ballast tank atmosphere volatile to combustion, which is a major safety hazard. The provision of sensors and monitoring of the ballast tank atmosphere may be a solution.

Another question is whether it will be easy to maintain the non-return valves leak proof. Regulation I/13F(3)(f) of MARPOL 73/78 prohibits the passing of cargo piping and similar piping to cargo tanks through ballast tanks, except for short lengths on specific exemptions.

Another problem is the electrostatic sparks that can occur by the splashing of oil cargo in the ballast tanks in case of an emergency cargo transfer. As the ballast tank atmosphere can be prone to combustion, electrostatic sparks during an emergency cargo transfer present an explosion risk, even though the Administration can allow such emergency cargo transfer under regulation I/23(5) of MARPOL 73/78. It appears illogical that in one regulation oil cargo transfer to ballast tanks is permitted and in another there is restriction on any permanent connections between oil cargo and ballast tanks. It may be reiterated that these observations are only possibilities and not probabilities.

Anders Björkman, the designer who invented the Coulombi Egg concept, was contacted in order to solicit his view on the above observations. About the piping connection between lower cargo tanks and upper ballast side tanks, the IMO raised the question based on the rule, during the design approved in 1997. Björkman's argument was that each piping connection was always located in dry cargo tank access trunks at a distance above cargo surface and would never be subjected to cargo pressure, except if the cargo tank was breached in a collision and grounding, when water pressed up oil in the access trunk. However, for approving the design, this connection on spill reduction was ignored.

With regard to the leak of the non-return valve from the lower cargo tank and ballast tank, Björkman claims that the leak can be easily detected and the ballast tank ventilated after lowering the inert gas pressure in the cargo tank. Further, some valve manufacturers have assured him that the valves would never leak. Another solution

seemed to be to add an absolutely tight disc, which would break only under cargo pressure and never break under inert gas pressure. The disc, in addition to the valve, would assure 100% tightness. In a ballast passage the non-return valves will be screwed down to prevent ballast water flow into the inert and empty cargo tanks. Regarding the electrostatic sparks during an emergency cargo transfer in the ballast tank atmosphere, he commented that such emergency cargo transfer could be allowed by the Administration under the relevant MARPOL regulation. He opined that IMO might have adopted the relevant regulation because such cargo transfer would take place at such a slow rate that electrostatic sparks would not occur.

#### **4. COBO PROPOSAL**

The Combination Of Basic Objectives (COBO) design is based on the principle of protected small hydrostatically balanced cargo tanks in the vulnerable zone and large cargo tanks in the safe zone. However, the minimum size of the cargo tanks is restricted by operational requirements (Laan, 1995b, pp. 358-359). Fig. 43 shows the objectives of tank size and location. Fig. 44 shows small outflow after side and bottom damage. Laan explains the features of the this design as follows:

##### **4.1. Oil outflow prevention**

1. Double side designed for protection (energy absorption) with three stringer decks, a crushable horizontal deck of mild steel with increased thickness and strong longitudinals, combined with flexible transverses.
2. Tank walls designed for penetration prevention with strong longitudinal flexible material (mild steel).
3. Facility to inert ballast tanks rapidly, for fire prevention.



4. Reduced width and height of cargo tanks by specific arrangement of longitudinal bulkheads and horizontal decks. Reduced effective length of the tank for reducing the oil outflow by intermediate transverse ECO-bulkheads<sup>5</sup>. (Fig. 45).
5. Prevention of initial outflow by hydrostatic balance. Reduction of secondary outflow by safety margin in hydrostatic balance caused by dynamic and tidal effects; emergency cargo transfer system with rupture discs, which rupture automatically during collision and allow part cargo transfer to opposite ballast tanks.

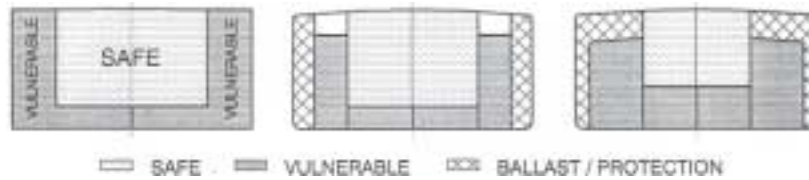

Fig. 43. Objective of tank size and location

(Source: Tanker Technology, 1995, June, p.358)

#### 4.2. Salvage & tank cleaning

The limited capacity of ballast tanks restricts the floodable volume and cargo tanks are hydrostatically balanced. The buoyancy loss of ballast tanks can be regained by transferring cargo from the centre tank to damaged ballast tank and expelling seawater. Tank cleaning is improved by the transverse on the topside. Purging, venting and gas freeing, and accessibility for maintenance are enabled through ECO-bulkhead holes.

#### 4.3. Building cost

The design has horizontal decks located high in wing tanks in order to locate the neutral axis near the half ship depth, which reduces material thickness. As structural stresses in laden condition are small, fatigue damage is reduced. Loads on mid-deck are reduced

<sup>5</sup> ECO-bulkhead, an innovative tanker swash bulkhead, features a watertight structure with a number of holes near the bottom and suitable for new and existing hulls (Laan, 1995, February, pp.109-111).

with the counter-acting pressure of cargo from the lower tanks and the absence of an ullage space with large dynamic sloshing loads, which is achieved by connecting the bottom cargo tank to both side bottom tanks by ECO-bulkheads. (See fig. 46). Efficient positioning of longitudinals and transverses reduces coating area approximately by 40% as compared to double hull and includes less material loss due to corrosion. The slope of the wing tank horizontal deck shifts the ballast sediments into the narrow double side. It is claimed that all these factors contribute to a reduction of the building cost by 5% compared to a standard double hull tanker.

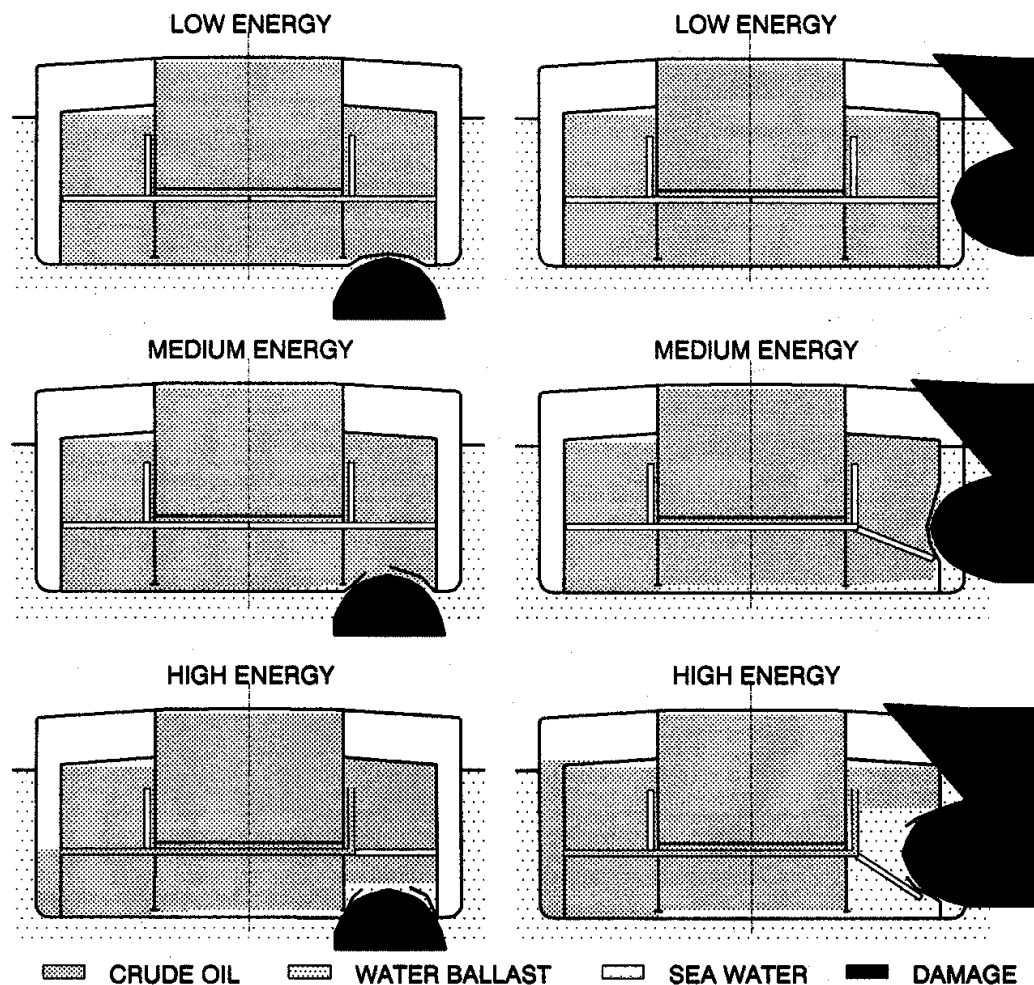

Fig. 44. Small outflow after side and bottom damage in the COBO design

(Source: Tanker Technology, 1995 June, p.358)

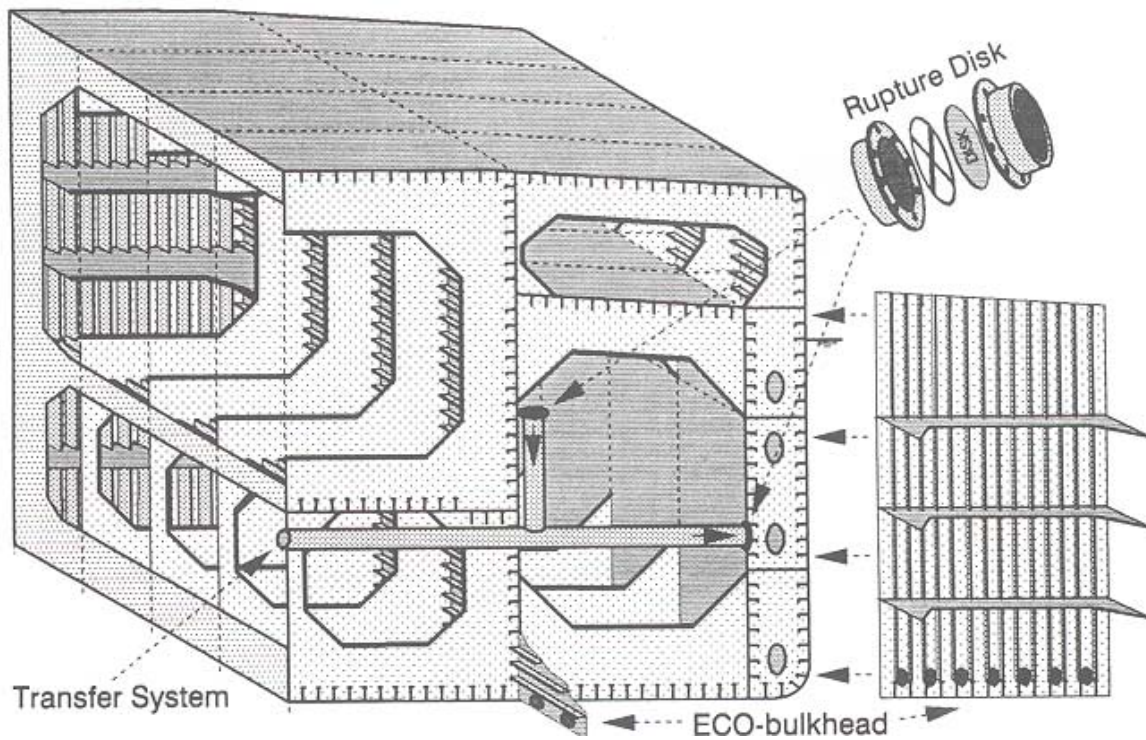

Fig. 45. The COBO midship section in three dimensions

(Source: Tanker Technology, 1995, June, p.359)

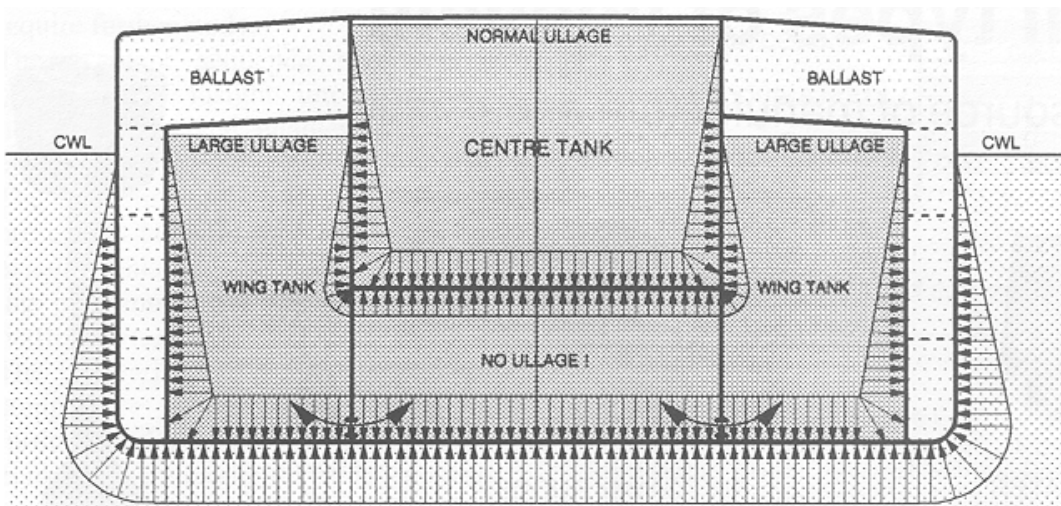

Fig. 46. Small structural loads of COBO in laden conditions

(Source: Tanker Technology, 1995, June, p.359)

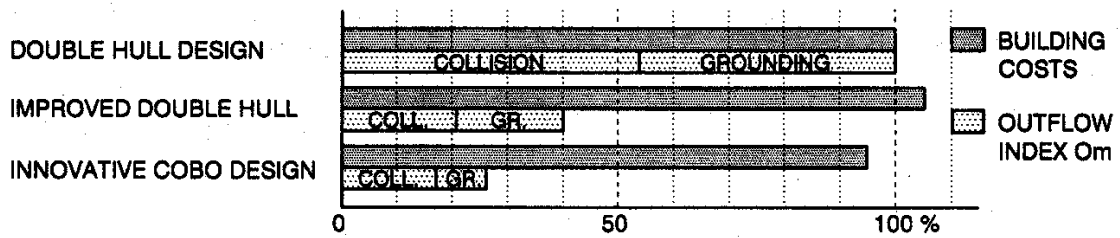

Fig. 47. An economical and ecological comparison

(Source: Tanker Technology, 1995 June, p.361)

The COBO concept features many advantages over a standard double hull tanker. Major advantages claimed are building cost reduction by 5% and oil outflow reduction by 73% (Fig. 47). Other advantages are - less area is exposed to corrosion requiring less tank coating, improved tank cleaning, purging and venting of bottom cargo tanks, less fatigue and sloshing loads, etc.

## 5. Other Alternative Concepts

There are many other advanced concepts, in addition to the alternatives to double hull design described. Cushing (1994, pp. 11-14) explains some of the development in peripheral tanks and proposed alternatives for new construction; some of them are briefly presented here. The layout of the MARC GUARDIAN series of curved plates, shown in fig.48, is a peripheral tank construction. The EPOCH system developed by Hitachi has no longitudinal bulkheads in the cargo area (Fig. 49). The SKARHAR design is a longitudinal framing system developed by the Skaarup Oil Corporation. A variation from the MHI's mid-deck is the INTERTANKO MID DECK developed by Embiricos, which employs the use of rescue tanks in the lower portion of the wing tanks, as shown in fig. 50.

The UNDER PRESSURE OR VACUUM system is a method that uses the principle of gravity to minimize oil outflow (Fig. 51). In the 1970's B. Stenstrom of Sweden, developed this system, which involves manual or automatic closing of pressure/vacuum vent valves to isolate a damaged tank or tanks. Use of pumps to maintain a vacuum above the cargo is another variation. The SPILLSTOP system, developed by M. Husain(U.S.), uses the inert gas system to maintain a negative pressure above the cargo in the cargo tanks, thereby simulating a hydrostatic balance with more cargo. This system is also known as the AMERICAN UNDER PRESSURE SYSTEM (AUPS).

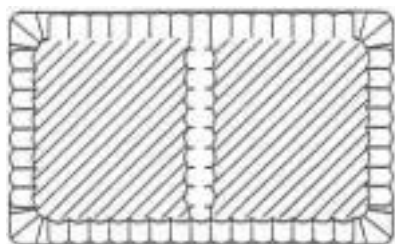

Fig. 48. MARC GUARDIAN

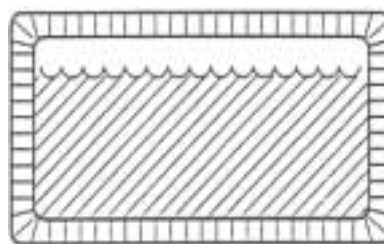

Fig. 49. EPOCH

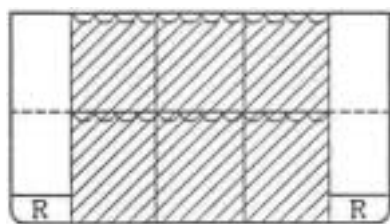

Fig. 50. INTERTANKO MID DECK

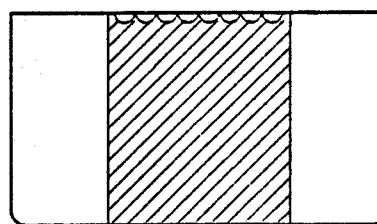

Fig. 51. UNDER PRESSURE

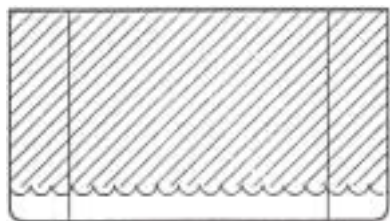

Fig. 52. IMAGINARY DOUBLE BOTTOM

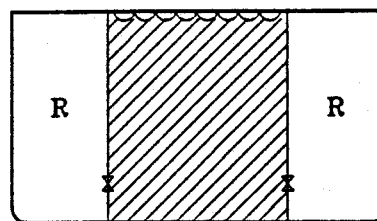

Fig. 53. SCOL



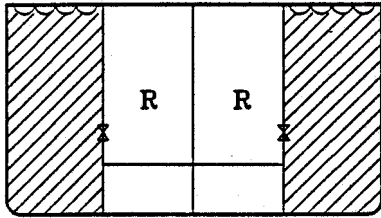

Fig. 54. POLIS

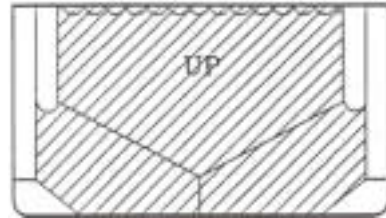

Fig. 55. POLMIS (UNDER PRESSURE)



Fig. 56. POLMIS BALLAST BAG

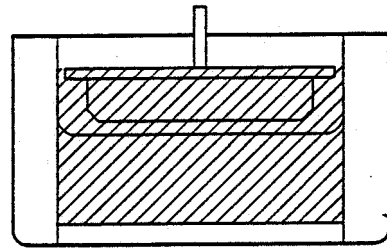

Fig. 57. DIATANK

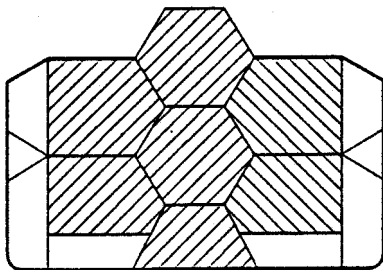

Fig. 58. HONYCOMB

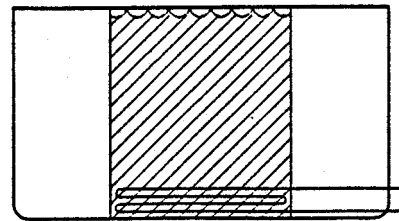

Fig. 59. STOBBS BRINE SYSTEM



(Source: Marine Log, 1994, April 6)

In the 1980's Wasemus of Norway, developed the IMAGINARY DOUBLE BOTTOM (IDB) concept (Fig. 52), where a layer of chemically treated seawater is used in the bottom of the cargo tanks of single hull tankers. In the event of grounding, the heavier seawater below the cargo oil will gravitate out until hydrostatic balance is reached between cargo oil inside the tank and water outside. In the EMERGENCY RAPID TRANSFER SYSTEM (ERTS) oil from damaged cargo tanks gravitate into rescue or

ballast tanks or bladders. The System for Controlled Oil Leakage (SCOL) is an example for ERTS (Fig. 53). In SCOL, ballast tanks act as rescue tanks. Blanked transfer pipes between cargo and ballast tanks have the blanks hydraulically sheared in case of an accident, permitting oil in damaged cargo tanks to quickly gravitate into rescue tanks.

The Pollution Limitation System (POLIS ) developed by George Paraskevopoulos is a rescue tank system intended for retrofitting into existing tank vessels (Fig. 54). The POLMIS system is a combination of the rescue tank system and mid-deck tanker concept. The system has a tapered centre tank (Fig. 55) or a ballast bag in the centre tanks (Fig.56). The EMERGENCY RESCUE SYSTEM (ERS) employs high capacity pumps to transfer cargo from damaged tanks into empty ballast tanks or bladders.

The DIATANK system employs the concept of a movable horizontally placed diaphragm to restrict the outflow of oil in grounding (Fig. 57). The HONYCOMB system, a multi-cellular system proposed in 1992 by Per Lindstrom of Sweden, utilizes a series of horizontal and sloping bulkheads, forming hexagonally shaped tanks (Fig. 58). Another unusual proposal by Stobbs of U.S.A. is STOBBS BRINE SYSTEM, which is supposed to create a rigid layer of petroleum in the bottom of the cargo tanks (Fig. 59).

To conclude, accidental oil outflow from a tanker can be reduced by the use of double hull, reduced tank size, and use of outflow prevention measures inside a tank. The study conducted by the IMO has proved that the mid-deck concept is superior to the double hull in limiting total amounts of oil spilled. The Coulombi Egg concept also provides an effective alternative to double hull in mitigating pollution. Many other technical alternatives such as the COBO proposal provide ideas for further advancement. However, until the US substantiates its reservations on well-documented scientific grounds or withdraws it, progress is effectively closed and the technological freeze will continue.

## CHAPTER 7

### Summary, Conclusion and Recommendations

#### 1. Summary & conclusion

We have seen in the previous chapters that the requirement to fit double hull or equivalent arrangements for new oil tankers is one of the most significant amendments to MARPOL 73/78. These amendments were adopted by the IMO in 1992. The writer has also discussed the *Exxon Valdez* disaster, which was caused by human error, and prompted the United States to adopt the OPA 90. One of the major provisions of the Act is the double hull requirement for new tank vessels operating in US waters. They have not approved any other alternative designs to double hull tank vessels.

The aftermath of the sinking of the 25-year old Maltese oil tanker *Erika* in December 1999 presented IMO with one of its biggest challenges in recent years. The disaster has woken up the international maritime community and in particular, the European Union (EU), of its consequences. The EU even suggested introducing an EC directive equivalent or even tougher than the OPA 90. Two separate regional requirements would have put areas outside the US and Europe at increased risk of oil pollution. It would also have seriously undermined the IMO as the only body for setting international maritime regulations. In April 2001, the IMO has agreed to a revised timetable for elimination of single hull tankers by 2015 or earlier, as one of the post-*Erika* measures.



Short-term experience of design, construction and operation of double hull tankers has presented many problems and risks, in addition to incurring more costs. With changed hull geometry there is a tendency for the reduction in scantling, particularly with the use of high-tension steel. But to fulfil the critical buckling stress requirements, the material dimensions must be increased beyond the corrosion limit. Apart from the above, high still water bending moment during ballast passage, high hull girder bending moments with evenly distributed cargo oil and ballast tanks, difficult welding in restricted double hull spaces, and stress concentrations in the structure with the sandwiched panels are some of the design and construction problems. The operational difficulties include inspection and monitoring of vast boundary areas of double hull space, gas freeing, ventilation, cleaning and maintenance of ballast space, protection of ballast tank coatings, maintaining stability during loading/unloading and ballasting/deballasting operations by avoiding excessive free surface effects, and effects of sloshing due to smooth and plain bulkhead panels in centre cargo tanks.

Risks due to corrosion and fatigue are higher in double hull tankers. With more surface area exposed to ballast water the corrosion risk is high in double hull tankers. In cargo space, the residual water from cargo and tank washings with the high temperature maintained by the 'thermos bottle effect', will contribute to high bacterial corrosion. The double hull tankers are prone to pitting corrosion caused by collection of water, either in uncoated oil tanks where the natural oil film from cargo oil is lost, or in damaged coating areas in ballast tanks. Pitting corrosion may introduce 'necking effect'. Fracture/cracks caused by fatigue are more in double hull tankers. Forced deflection due to stresses, hot spot stresses and corrosive environment are additional factors in double hull tankers contributing to fatigue damages. Reports of explosive atmosphere in ballast tanks due to leak of oil cargo and vapour through the cracks in the inner shell of double hull tankers are usual in maritime media and a spark in such tank can lead to a major catastrophe.

Although the IMO has approved the concepts of Mid-deck and Coulombi Egg designs as alternatives to the double hull, shipping companies have not yet come forward to order ships of these designs. In the opinion of this writer, the reasons are identified as follows. Firstly, the United States accounts for about 30% of the total world waterborne oil movement ('Free competition', 1999, p.6). The industry will not dare to make huge investments for ships with restricted trade limits, simply because the United States has not approved the alternative designs. Secondly, with the fast changing scenario in maritime regulations with every maritime disaster, as it happened with the *Torrey Canyon*, the *Exxon Valdez* and the *Erika* disasters, the probability of risk that would be taken by the industry with no experience in operating such tankers, will be high. This situation has created a technological freeze in developing alternative designs. Shipping experts around the world have been of the opinion that the political decision to implement double hull design as a mandatory requirement was taken in haste, which was a major deviation from the existing system developed over many years.

## **2. Recommendations**

In view of the foregoing discussions with regard to double hull tankers, introduced in feverish sessions by the United States and IMO with the intention of mitigating pollution, which have generated other serious problems, the following recommendations are submitted.

1. As IMO is the only international body for setting international maritime regulations, any actions by member states or regions displacing the decisions of IMO will seriously undermine the IMO's position and should be avoided.
2. A decision such as the mandatory requirement of double hull for oil tankers, which is a deviation from the design practices developed over years, should be implemented only after careful consideration of all aspects, supported by

thorough theoretical and practical studies and after ensuring its implications in all spheres including the safety and viability in all regions, as well as the financial, commercial and economic aspects.

3. Implementation of a technical regulation such as double hull design should not bear short-term political benefits, nor react to public outcry created by catastrophic events like the *Exxon Valdez* or the *Erika* disasters, but be based on sound technical information and knowledge.
4. While implementing a mandatory design by regulation, the authorities should encourage the industry to develop better designs by way of incentives and financial support, and in no case should a technological freeze be created as it happened when the OPA 90 was introduced.
5. While adopting any international regulation, such as for prevention of pollution at sea, the objective should not deviate from the goal of safer ships and cleaner oceans.

Finally, it is submitted that the intention of the writer is not to question the validity of double hull designs, but to impress the authorities of certain issues for more careful consideration. Further, in the opinion of the writer, decision to implement the double hull design was taken hastily. Undoubtedly it has far reaching dimensions and resulting implications.

## References

- Abe, A. & Niihara, Y. (2000, June). Assessment system of strength of double hull structure after buckling. *J Soc Naval Architects Japan*, 187, 221-228.
- Abe, M. (1990). *Classification Societies and International Association of Classification Societies (IACS)*. Unpublished lecture handout, World Maritime University, Malmö, Sweden.
- Arctic/ Northern Culture. (1999, March 24). *The Exxon Valdez Oil Spill Disaster*. Retrieved May 3, 2001 from: <http://arcticculture.about.com/culture/arcticculture/library/weekly/aa032499.htm>
- Birkholz, D. (1997). *Preservation of Iron ships in the marine environment*. Retrieved June 9, 2001 from: <http://www.maritime.org/conf/conf-birkholz.htm>
- Björkman, A. (1992, June). The VLCC for the year 2000. *Naval Architect*, (6), 321-328.
- Björkman, A. (1993, June). Towards a safer supertanker : the Coulombi Egg. *Naval Architect*, 6 (6), 293-297.
- Björkman, A. (1997a). *The Coulombi Egg Tanker: General arrangement and structure*. Retrieved April 30, 2001 from: [http://heiwaco.tripod.com/ce\\_structure.htm](http://heiwaco.tripod.com/ce_structure.htm)
- Björkman, A. (1997b). *The Coulombi Egg Tanker: The Magic Egg!* Retrieved April 30, 2001 from: [http://heiwaco.tripod.com/ce\\_coulombiegg.htm](http://heiwaco.tripod.com/ce_coulombiegg.htm)
- Björkman, A. (2000). *The Coulombi Egg Tanker and the Erika and Baltic Carrier accidents*. Retrieved May 19, 2000 from: <http://heiwaco.tripod.com/professionnels.htm>
- Breaking with tradition: Is Coulombi Egg design the way forward? (1996, May 9). *Fairplay*, 328 (5866), 38-39.
- Cheeseman, B. (2001). *Amoco Cadiz disaster, 1978*. Retrieved April 13, 2001 from: <http://www.aber.ac.uk/iges/cti-g/STHAZARDS/seaempres/amocohtml>

Coulombi Egg gains IMO approval. (1997, April 14). *Fairplay Daily News*. Retrieved April 15, 2001 from: <http://fairplay.co.uk/magazine/searchpage.asp?Src=coulombi+egg>

Coulombi Egg Tanker- Particulars. (2000, January). *Marine Digital*. Retrieved April 30, 2001 from: [http://www.marinedigital.com/en/products\\_sell/ctd/particulars.asp](http://www.marinedigital.com/en/products_sell/ctd/particulars.asp)

Cushing, C.R. (1994). *Meeting the United States Coast Guard's proposed rules for existing single hull tankers; what are the options?* Paper presented at Marine Log: Ship Repair and Maintenance '94 Conference, New Orleans, April 6, 1994.

Derrett, D.R. (1990). *Ship Stability for Masters and Mates*. Oxford: Butterworth-Heinemann.

Det Norske Veritas (DNV). (1992). *Structural collapse of cargo pipes in tank* (Casualty information No. 1/92). Retrieved April 16, 2001 from: <http://exchange.dnv.com/ServiceExperience/CasualtyInformation/CellPage.asp?Row=2&Col=7>

DNV. (1999). *Listing of double hull tanker during cargo operation* (Casualty information No. 3/99). Retrieved May 17, 2001 from: <http://exchange.dnv.com/ServiceExperience/CasualtyInformation/CellPage.asp?Row=2&Col=7>

Double-hull concerns and countermeasures. (2000, June). *The Naval Architect*, 18.

Dugstad, G. (2000). *Fatigue hull damages of single hull VLCC's*. (DNV paper series, No. 2000-P010). Oslo: DNV.

The Erika accident and issues raised. (2000, March). *Intertanko Monte Carlo Tanker Event 9-13 April 2000: Intertanko Briefing Notes*. Retrieved May 18, 2001 from: <http://www.intertanko.com/conferences/tankerevent2000/erika/>

Erika- principal particulars. (2000, April). *Intertanko: The Tanker newsletter*, 4.

Erika provokes questions. (2000, April). *Intertanko: The Tanker newsletter*, 4.

Equasis. (2000). *About Equasis*. Retrieved May 21, 2001 from: <http://www.equasis.org/>

EU - EP. (2001, June 15). *The Erika II package*. Retrieved July 27, 2001 from: <http://www.health.fgov.be/WHI3/krant/krantarch2001/kranttekstjune1/010615m07eu.htm>

Fact Monster. (2001). *Oil Spills*. Retrieved April 14, 2001 from: <http://www.factmonster.com/ipka/A0001451.html>

- First fire, now brimstone is a hazard for tankers. (2001, June). *Fairplay Solutions*, 27.
- Free competition in the global tanker market to the benefit of the consumer. (1999, April). *Tankers the link to 'The American way of life'*. Presentation at Intertanko Houston Tanker Event Conference & Exhibition.
- French say poor maintenance and rust sank Erika. (2001, February). *The Sea*, 149.
- Gray, W.O. (1997, September 24). *CMA: OPA phase-out requirements for existing single hull tankers*. Retrieved May 3, 2001 from: [http://www.cmaconnect.com/archive/997opaimo\\_2.html](http://www.cmaconnect.com/archive/997opaimo_2.html)
- Griffin, A. (1999). *MARPOL 73/78 and vessel pollution: A glass half full or half empty?* Retrieved May 12, 2001 from: <http://www.law.indiana.edu/glsj/vol1/griffin.html>
- Hah, J & Akiba, T. (1994, June). Revolutionary alternative to the double-hull VLCC. *The Naval Architect*, 268-272.
- Hooke, N. (1997). *Maritime casualties, 1963- 1996* (2<sup>nd</sup> ed.). London: LLP.
- Horrocks, C. (2000). *Background to the shipping industry*. Unpublished lecture handout, World Maritime University, Malmö, Sweden.
- The Indian Mariner's News Desk. (2000a, December 4). *The first three 'Erika' proposals*. Retrieved May 22, 2001 from: <http://www.indianmariner.com/1%20prelaunch.htm>
- The Indian Mariner's News Desk. (2000b, December 26). *Follow-up on 'Erika' accident at the end of the year 2000*. Retrieved May 22, 2001 from: <http://www.indianmariner.com/follow-up%20on%20erika.htm>
- International Maritime Organization (IMO). (1992). Steering committee report backs double-hull and mid-deck tanker designs. *IMO News*, (1), 3-4.
- IMO. (1995). *Code on Intact Stability*. London: Author.
- IMO. (1997a). *30 years on what has happened since the Torrey Canyon*. Retrieved April 14, 2001 from: <http://www.imo.org/news/197/tankers.htm>
- IMO. (1997b). Resolution A.868(20): Guidelines for the control and management of ships' ballast water to minimize the transfer of harmful aquatic organisms and pathogens. *Resolutions and other decisions of the 20<sup>th</sup> assembly* (pp. 222-235). London: Author.

- IMO. (1997c). MARPOL 73/78: Consolidated Edition. London: Author.
- IMO. (1998, October). MARPOL – 25 years. *Focus on IMO*, 1-28.
- IMO. (2000). *IMO Briefing: IMO orders study to assess impact of ERIKA proposals*. Retrieved March 20, 2001 from: <http://www.imo.org/imo/briefing/2000/fax13a.htm>
- IMO. (2001a). *Marine Pollution: Frequently asked questions (FAQs)*. Retrieved April 13, 2001 from: <http://www.imo.org/imo/convent/pollute.htm>
- IMO. (2001b, April). MEPC 46<sup>th</sup> session: *Single-hull phase out and other post-Erika measures*. Retrieved May 23, 2001 from: : [http://www.imo.org/Newsroom/contents.asp?topic\\_id=109&doc\\_id=774](http://www.imo.org/Newsroom/contents.asp?topic_id=109&doc_id=774)
- IMO. Global Ballast Water Management Programme. (2001c, March). *Stopping the ballast water stowaways*. London: Programme Coordination Unit, IMO.
- In the wake of Erika. (2000). *Norwegian Shipowners Association Annual Report 2000*. Retrieved July 27, 2001 from: <http://www.rederi.no/en/library/annualreport/2000/14.html>
- International Registries Inc (IRI). (2000, February 29). *Erika's aftermath*. Retrieved May 22, 2001 from: <http://www.register-iri.com/content/press/minews3.cfm>
- The International Tanker Owners Pollution Federation (ITOPF). (2001). *Historical Data: Statistics*. Retrieved April 15, 2001 from: <http://www.itopf.com/stats.html>
- Intertanko. (2000, November 3). *Hydrostatic Balance Loading on MARPOL Tankers (SBT/PL)*. Retrieved March 23, 2001 from: <http://www.intertanko.com/members/artikkel.asp?id=1856>
- Jönsson, J. Å. (2001). *Survey & Certification*. . Unpublished lecture handout, World Maritime University, Malmö, Sweden.
- Julian, M. (2000). The work of IMO in protecting the marine environment. *BIMCO review, 2000* (pp. 71-74). London: BIMCO.
- Karafiath, G. & Bell, R. M. (1993). *Model tests of accidental oil spill due to grounding*. Retrieved June 23, 2001 from: [http://www50.dt.navy.mil/reports/oil\\_tests/](http://www50.dt.navy.mil/reports/oil_tests/)
- Laan, M. (1995a, February). ECO-bulkhead: oil outflow reduction by simple Archimedes! *The Naval Architect*, 109-111.

- Laan, M. (1995b, June). Innovative tanker design and the COBO concept. *The Naval Architect*, 355-361.
- Leech, S. (2000, September 25-26). *The developments in marine liabilities from legal perspective*. Speech given at the Marine Forum 2000, Athens, Greece , 25 - 26 September 2000. Retrieved May 22, 2001 from:  
<http://www.mareforum.com/LEECH%20Stirling,%20Clyde%20&%20Co..htm>
- Loy, J.M. (1999, March 24). *U.S. Coast Guard statement on the Oil Pollution Act 1990 before the sub committees*. Retrieved May 5, 2001 from:  
<http://www.house.gov/transportation/cgmt/03-24-99/loy.htm>
- Magelssen, W. (1996, October). *Double hull- a political reality- for and against*. (DNV paper series, No. 97-P001). Oslo: DNV.
- Magelssen, W. (1997, April). *The effectiveness of Double hull (DH) tankers- thoughts about some factors of importance*. (DNV paper series, No. 97-P002). Oslo: DNV.
- Magelssen, W. (2000a, February). *Fatigue: The challenge for modern ship design*. (DNV paper series, No. 2000-P004). Oslo: DNV.
- Magelssen, W. (2000b, June). *Corrosion/ Corrosion Protection: What impact will this have on modern ship design?* (DNV paper series, No. 2000-P008). Oslo: DNV.
- Marton, G.S. (1984). *Tanker operations*. Maryland: Cornell Maritime Press.
- McFarland, R.E. (2000). *Exxon Valdez*. Unpublished lecture handout, World Maritime University, Malmö, Sweden.
- Mid-deck design limits oil outflow. (1993, April). *The Motorship*, 21-24.
- The mid-deck supertanker: Industry awaits completion of IMO study. (1991, October). *The Naval Architecture*, 445.
- Mitsubishi's mid-deck tanker still awaits an order. (1992, October). *The Naval Architecture*, 481.
- National Research Council (USA) (NRC). (1991). *Tanker Spills: Prevention by Design*. Washington, D.C: National Academic Press.



Oil Spill Intelligence Report (OSIR). (2000). *Oil-Spill Related Fact Summaries: Major provisions of the Oil Pollution Act of 1990 (OPA 90)*. Retrieved May 5, 2001 from: <http://cutter.com/osir/osirfact.htm>

Pang, S. & Williams, F. (2001). *Oil spills and their impact on shipping laws*. Retrieved May 6, 2001 from: <http://www.platts.com/oilspills/uschanges.shtml>

Parry, J. (2000). *Tanker world: Corrosion sank Erika*. Retrieved May 18, 2001 from: [http://www.tankerworld.com/news/nov2000/week201100/news\\_23112000\\_7.htm](http://www.tankerworld.com/news/nov2000/week201100/news_23112000_7.htm)

Patin, S. (1999). *Accidents during the offshore oil and gas development*. Retrieved March 22, 2001 from: <http://www.offshore-environment.com/accidents.html>

Strong improvement in the environmental performance of tankers. (1999, April). *Tankers the link to 'The American way of life'*. Presentation at Intertanko Houston Tanker Event Conference & Exhibition.

Tamama, H. (1998). *Summary of working paper No. 115-1998: Oil spilling from a grounded mid-deck tanker*. Retrieved June 23, 2001 from: [http://www.fni.no/insrop/INSROPSummary\\_of\\_Working\\_Paper\\_No\\_1151.html](http://www.fni.no/insrop/INSROPSummary_of_Working_Paper_No_1151.html)

Tanker 'so corroded it fell apart'. (2000, December). *TDGOODS.COM*. Retrieved May 19, 2001 from: <http://www.TDGOODS.COM/Articles/article123.htm>

Tanker Structure Co-operative Forum (TSCF). (1995). *Guidelines for the inspection and maintenance of double hull tanker structures*. London: Witherby & Co. Ltd.

Tanker transport is the basis for the welfare of U.S. citizens. (1999, April). *Tankers the link to 'The American way of life'*. Presentation at Intertanko Houston Tanker Event Conference & Exhibition.

Trade Environment Database (TED). (2000, December). *Exxon Valdez disaster*. Retrieved May 2, 2001 from: <http://www.american.edu/ted/exxon.htm>

True, W.R. (2000, November 20). IMO plans to speed single-hulls' phase out; VLCCs hit hard. *Oil & Gas Journal*, 98, (47), 68-69.

US Congress (101<sup>st</sup>, 2<sup>nd</sup> Session 1990). (1990). *Oil Pollution Act of 1990*. Washington, D.C: USA Senate.