

1999

# Port system analysis

Zhaoning Wang  
*World Maritime University*

Follow this and additional works at: [http://commons.wmu.se/all\\_dissertations](http://commons.wmu.se/all_dissertations)



Part of the [Infrastructure Commons](#)

---

## Recommended Citation

Wang, Zhaoning, "Port system analysis" (1999). *World Maritime University Dissertations*. 216.  
[http://commons.wmu.se/all\\_dissertations/216](http://commons.wmu.se/all_dissertations/216)

This Dissertation is brought to you courtesy of Maritime Commons. Open Access items may be downloaded for non-commercial, fair use academic purposes. No items may be hosted on another server or web site without express written permission from the World Maritime University. For more information, please contact [library@wmu.se](mailto:library@wmu.se).

**WORLD MARITIME UNIVERSITY**

Malmö, Sweden

**PORT SYSTEM ANALYSIS**

By

**WANG ZHAONING**

**People's Republic of China**

A dissertation submitted to the World Maritime University in partial  
fulfilment of the requirements for the award of the degree of

**MASTER OF SCIENCE**

in

**SHIPPING MANAGEMENT**

**1999**

## DECLARATION

I certify that the material in this dissertation that is not my own work has been identified, and that no material is included for which a degree has previously been conferred on me.

The contents of this dissertation reflect my own personal views, and are not necessarily endorsed by the University.

.....

.....

Supervised by:

Name: ..... Ma Shuo .....

Office: Course professor, Port- and Shipping Management .....

World Maritime University

Assessor:

Name: ..... Patrick Donner .....

Office: ..... Associate Professor, Shipping Management .....

Institution/organization: ..... World Maritime University .....

Co-Assessor:

Name: ..... Hercules Haralambides .....

Office: ..... Professor of maritime economics .....

Institution/organization: ..... ERASMUS University .....

## Acknowledgement

I feel deeply grateful to my university: Dalian Marine University and Global Foundation who offered this nice opportunity for me to study in World Maritime University.

I appreciate World Maritime University faculty and staff for their teaching and services. Particularly, I would like to thank Port- and Shipping course Professor, Ma Shuo for his valuable supervision. Each time his instruction and criticism have broaden my eyes and made me keep asking myself “why” in every step on my research. At the beginning, I feel it was not easy to adjust to his strict style, as long as I have done more and more, I recognise how nice to be under this kind of supervision. I would say, by writing this dissertation, I have learned more than I expected. I really feel proud to be under his supervision.

I would also like to say thanks to Professor Patrick Donner and Visiting Professor Hercules Haralambides for their lectures and kindly guidance and assessment.

I would thank the librarians for their patient assistance. I would also thank my classmate Tecle for his help in my dissertation work.

I owe my parents-in-law, Fang Chuanjia and Lin Qiuzi, my parents, Wang Xianhui and Ji Zhiwen , my husband, Fangbin, and my daughter, Liangliang, a lot. Their loves and inspirations are the consistent energy sources of my study. My mother-in-law’s support always made me feel indebted because she took place of me caring my baby and it was not easy to take care of a little baby in her sixties.

I know I should say too much thanks to many people, finally, I would like to attribute my modest work to my country for her future port and shipping development.

## Abstract

System approach can well apply to the conduct of port activities. System approaches are used to solve some specific port problems, such as port congestion. However, from system view point, we know that the best possible performance of each part of a system seldom adds up to the best possible performance of the system as a whole. For this reason, the author of this dissertation tries to introduce system analysis technique to the analysing of port system in a whole system scale through top-bottom analysis method. It is a test of system approach used in management aspect in comparison with other system methods.

The author also tempts to set up a whole sketch of port business structure in order to prepare a base for a port model to be set up in the future.

The basic system theory and its relation to port have been discussed in the first chapter of the dissertation. By applying the system approach in port, it has been deduced that port is a physical and social system, and it is also an open system instead of a closed system. The interrelationships within port can be categorised in three types: tangible, half-tangible and intangible.

Chapter two examines port system in a general view, three driving forces of port operation are drawn and port system outlook is given. In addition, the analysis tool is defined in this chapter, which is used for the further discussion in chapter three.

In chapter three, the author has analysed a subsystem: cargo operation system within port system based on the structure set up in the previous chapter. It is a part job of

whole port system set-up. It is a demonstration of system analysis technique used in port running. It is believed that it is quite feasible and effective to use system approach for port development. It is a good method for sustainable development of port by sharing resources and information.

Chapter four describes two cases that show how a port manager can benefit from the system vision.

Finally, the conclusion of this dissertation argues that the system approaches is an appropriate tool of management feasibility in port management and the author's suggestion. Further suggestion are also made.

## Table of Contents

<b>Declaration.....</b>	<b>ii</b>
<b>Acknowledgement.....</b>	<b>iii</b>
<b>Abstract.....</b>	<b>v</b>
<b>Table of Contents .....</b>	<b>vii</b>
<b>List of Figures .....</b>	<b>ix</b>
<b>List of Abbreviations .....</b>	<b>x</b>
<b>Introduction.....</b>	<b>1</b>
<b>Chapter 1: System theory and port .....</b>	<b>5</b>
1.1. What is a port? .....	5
1.2. Port core functions .....	6
1.3. Port is a system.....	6
1.4. Main system concepts applied to port.....	8
1.5. Interrelationships within port.....	10
1.6. What kind of system is a port?.....	11
1.7. Difference between system approach and non-system approach.....	12
1.8. System Integration.....	13
<b>Chapter 2: System analysis of port in the general view.....</b>	<b>17</b>
2.1. System technology and its application in port .....	17
2.2. System analysing approaches .....	19
2.3. Port system major elements .....	20
2.4. Port system driving forces.....	20
2.5. Tools of analysis.....	22
2.6. Port system and subsystems structure .....	23
2.7. 0-level system analysis .....	25



---

2.8. 1-level system analysis .....	26
<b>Chapter 3: Cargo operation system.....</b>	<b>30</b>
3.1. Cargo moving routes in port.....	30
3.2. Cargo operation subsystem structure .....	32
3.3. 1.1.1: Cargo operation planning.....	37
3.4. 1.1.2 Ship operation.....	40
3.5. Quay transfer operation.....	44
3.6. 1.1.4 Storage .....	47
3.7. 1.1.5 Receipt/Delivery (Distribution) .....	48
<b>Chapter 4: System vision of manager: cases .....</b>	<b>51</b>
4.1. <i>Case 1</i> : Hewlett-Packard's Systems Approach in Distribution system.....	51
4.2. <i>Case 2</i> : System vision of Port of Hamburg's Manager .....	55
4.3. Assumption.....	58
4.4. Remarks .....	59
<b>Conclusion .....</b>	<b>61</b>
<b>Bibliography .....</b>	<b>64</b>

**LIST OF FIGURES**

Figure 2-1	0-level system analysis	26
Figure 2-2	1-level system analysis	27
Figure 3-1	UNCTAD: Two routes of cargo movement	32
Figure 3-2	1.1 Cargo operation	36
Figure 3-3	1.1.1 Cargo operation planning	37
Figure 3-4	1.1.1.1 Pre-arrival planning	39
Figure 3-5	1.1.2 Ship operation	42
Figure 3-6	1.1.2.2 Cargo loading	43
Figure 3-7	1.1.2.3 Cargo unloading	43
Figure 3-8	1.1.3 Quay transfer operation	44
Figure 3-9	1.1.4 Storage operation	46
Figure 3-10	1.1.5 Receipt/Delivery(Distribution) operation	48
Figure 4-1	The state of Hamburg and its Port	55
Figure 4-2	Analysis of Hamburg Port manager's vision	58

## **LIST OF ABBREVIATIONS**

ESPO	European Sea Ports Organisation
IPP	Improve Port Performance
UNCTAD	United Nations Conference on Trade and Development

## Introduction

Actually, people involved in port have already accepted that system ideas are very important for management purpose and port is a system. We could find a lot of “system “ wording in different port publications. But why we still say that port is a system? This is because by and large the system is not widely used in the decision making in port. This dissertation tries to analyse port in a system view and give an answer to this question.

In addition, when people talk about system, model is inevitable considered. The advantages of model are well known--un-ambiguity, possibility of strict deduction, verifiability by observed data or functions. Trying to propose a model for port is also an intention of the author, given the time and length constraints of this dissertation, the author could just give a model structure of port and discuss a small subsystem within port system in more detail. The other parts of this system are to be considered later. This dissertation would dedicate its contribution to port management for three categories of users:

1: Port top-level manager:

If we compare the common organisation structure with analysed system structure, we will see in system analysing method, the manager will know:

- What flows go between the different functions and how they relate to each other instead of just knowing what is the hierarchy structure of port organisation.
- How the flows drive the system work,
- What are the inputs and outputs within the subsystem under his jurisdiction. How they go through the system.

System analysis results will indicate more than a general structure graph.

2: Port middle-level manager:

- Knowing not only the functions within his authority, but also inputs and outputs, what are his responsibilities and rights.
- Knowing what his above functions and relations with his work,
- What is his next work and under his control what his subordinate should do
- How to distribute his work to his subordinate and how to control and assess.

3: Port implementation-level manager.

- Know what is his responsibilities by knowing the whole system and what his role in the whole system.

Small elements or small functions could have big influence on whole system. In this sense, system analysis may also be a good means to decrease human errors.

Actually, few people consider that what they have done has a big influence on the whole system and consequently on themselves, they just think that what they should do and do it and not consider from a whole system point of view.

In analysing procedure, the author has tried to sketch an overall image of the port system to all above people.

Generally speaking, ports more or less have the same functions, such as loading/unloading, storage, and so no. However, some ports are more efficient than the others. From system point of view, a system analysis method gives an explanation to this question. It will also present a new methodology for port managers.

From the system point of view, we may know the system idea: A part optimal does not mean that the whole system is optimal.

For port is also the same, even port core business is dealing with ships and cargoes, just a most efficient berth does not mean a efficient or profitable port in the whole. A bad documentation procedure may block all the port.

Some system methods have been used for solving specific practical problems in port, such as simulation for solving port congestion problem. However, system approach is less used on the senior level. That is maybe the reason some developed technology could not be used effectively in the real practical work and some people even begin to suspect their usefulness. In fact, the useful things just have been used for work like painting a hand, it is useful, of course, but not as expected effective.

In this sense, a new way of thinking is needed and the author will try to test a new method to analyse port from a system view point from the general to specific details.

## Chapter 1:

# System theory and port

Nodes (port, towns, villages), lines, (railroads, highways, air routes, inland waters, marine routes) and flows (movements of vehicles on these routes with cargoes and people) are three main elements of transportation.

The port is a particularly important node since it lies at the interfaces, between the sea and land link, at the point where enormous flows of goods or people are transferred from marine vehicles and vice versa. The port is thus a critical subsystem within the total transport system.

### 1.1. What is a port?

ESPO defines port as "*an area of land and water including facilities destined mainly for receiving vessels, loading, unloading and storing cargoes, receiving and delivering the cargoes from/to land transport means; they may also include activities of firms linked to the sea-borne trade*".

Port is not only a transfer point between sea and land but also a logistical platform.

Port definition is a wide one both include these above two aspects.



## 1.2. Port core functions

As a port, whatever the nature of its trade, it must provide certain essential facilities and functions: (UNCTAD)

- ◆ A conservancy service, to give ships safe access to the port and protection when at berth or anchorage: the provision of navigational aids (such as lights, buoys and markers) access channels, breakwaters and other engineering works. As ships have got bigger, the conservancy function of ports has increased in importance, particularly the dredging of deepwater channels.
- ◆ Pilotage and towage: the provision of pilots and tugs and other vessels to help ships to manoeuvre safely into and out of port.
- ◆ Civil engineering: the construction of quays, wharves, roads, parking areas, transit sheds and warehouses, the surfacing of open yards, and the building of workshops and offices.
- ◆ Operation of cargo-handling facilities: quayside cranes, mobile mechanical handling equipment (forklift trucks, tractor-trailers, mobile cranes, etc.), transit storage areas, and the labour force.
- ◆ Ancillary service: a range of less vital services that play their part in servicing the shipowner and cargo owner.

The primary function of a port is to transfer cargo between maritime and inland transport quickly and efficiently.

## 1.3. Port is a system

Rapid technological changes and globalisation of trade have fostered a revolution in transport.

This in turn has caused major changes in the functions and uses of ports. Technological developments in ports have increased cargo-handling rates (thereby reducing port time), improved operational methods, facilitated sea channel and landside access, introduced the potential for completely automated navigational guidance, and introduced handling of new physical forms of cargoes.

These changes are dynamic and will continue to influence port as well as transportation system design, construction, and operation.

This revolution has been accompanied concurrently by traditional role of the sea port, fostering a new set of concepts governing the design and location of port facilities which more realistically reflect the needs of ocean transportation as being only one subsystem of complex inter-modal transportation and distribution system.

The economic consequences of decaying port systems usually affect a large segment of economic and commercial activity.

Port system has a lot of elements involved, that including cargo handling operations, relations between people and equipment, and innumerable financial, economic social and political problems.

Since so many resources have to be marshalled (labour, equipment, materials and storage space) and so many different parties are involved (shippers, ship's agents, stevedoring and trucking companies, railway corporations, customs officials, etc.)

Port is not just a matter of equipment and vehicles in operation, but is a wholly entity to be planned and arranged. In port, numerable problems need to be solved in production, commerce, etc.

Port is a system or a subsystem of the whole transportation system. For this purpose, “system approach” became necessary.

### **1.4. Main system concepts applied to port**

*“A system can be defined as a set of elements standing in interrelations among themselves and with environment.*

*A system consists of two basic components: elements and interrelationships.*

That is, A system is made of at least two or more parts (elements) that are physically or logically interrelated to each other.

Now we will see what is the real meaning of system, what is the difference of it comparing common entity.

In dealing with complexes of “elements” three different kinds of distinction may be made-i.e. (Ludwig,1973)

- 1, According to their *number*,
2. According to their *species*;
3. According to their *relations* of elements.

The following simple graphical illustration may clarify this point:

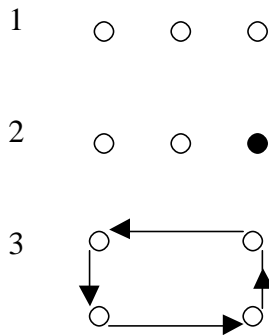

In cases 1 and 2, the complex may be understood as the sum of elements considered in isolation. In case 3, not only the elements should be known, but also the relations between them.

Characteristics of the first kind may be called summative, of the second kind constitutive. We can also say that summative characteristics of an element are those which are the same within and outside the complex; they may therefore be obtained by means of summation of characteristics and behaviour of elements as known in isolation. Constitutive characteristics are those which are dependent on the specific relations within the complex; for understanding such characteristics we therefore must know not only the parts, but also the relations.

*From system perspective, this whole is more than the sum total of the parts of the system.*

*The essential thing is that the system is composed of interrelated parts but can be perceived as a whole.*

As a system, port is not just a terminal for cargo loading/unloading or storage, it has also many other functions which have close relationships with these functions and both of them co-operate together to make everything work smoothly. This will be interpreted later in this dissertation.

## 1.5. Interrelationships within port

*The interrelationships between port activities can be tangible, half-tangible or intangible.*

The tangible degree usually could be measured by whether it could be modelled. Models are usually good methodology expressing the relations between elements. Generally there are two kinds of models: mathematics model and verbal model.

Tangible interrelationship:

For instance, port indicators can measure the relations, between efficiency of port cargo handling with port throughput. This is tangible and could be described by mathematical way.

Mathematics model essentially means the existence of an algorithm, which is much more precise than that of ordinary language. History of science attests that expression in ordinary language often preceded mathematical formulation, i. e. , invention of an algorithm .

Half-tangible interrelationship:

The relationship between world trade and port throughput is apparently close, but to what extent, how much, it is far beyond a mathematics formula description until now, it is just can be given in a verbal model , or a mathematics model in a limited extent.

A verbal model is better than no model at all. or a model which, because it can be formulated mathematically, is forcibly imposed upon and falsifies reality.

In-tangible interrelationship:

If there is a political event, maybe it will also has some influence on port working, one port may has more trade and this is opposite in another one. To grasp relation between political event and port throughput is impossible. This is intangible.

The system viewpoint has penetrated, and has indeed proved indispensable. Concept of system can be defined and developed in different ways as required by the objectives of research, and as reflecting different aspects of the port.

## **1.6. What kind of system is a port?**

*Port is a physical and social system.*

A system could be a concrete physical thing, such as an automobile, a methodology for performing some tasks or something abstract, such as in a philosophical system or a social system.

Since port has its infrastructure, it is a physical system, in addition it involves a lot social activities, such as government policies, customs authorities activities, etc. It is also a social system.

*Port is an open system instead of a closed system.*

In order to give this interpretation, we need to distinguish two different systems: close system and open system.

*Close system:* System is isolated from its environment.(Ludwig,1973)

In a closed system, a certain quantity, called entropy, must increase to a maximum, and eventually the process comes to a stop at a state of equilibrium.

However, we find systems by their very nature and definition is not closed systems. They are open systems.

*Open system:* (Ludwig,1973)

Is defined as a system in exchange of matter with its environment, presenting import and export, building up and breaking down of its material components.

A port need to get cargo flow from world trade in order to maintain its work, this can be simply regarded as its input, and it also need to arrange the cargoes in storage delivery to its destination, which is outsider of the port system. This can be thought as an output.

In this term, port must exchange its components with its environment and it relies on its good environment, such as good world seaborne trade, that is exactly a typical feature of open system. So: *Port is an open system.*

## **1.7. Difference between system approach and non-system approach**

Classic science in its diverse disciplines tried to isolate the elements of the observed object, expecting that by putting them together again, conceptually or experimentally, the whole or system would result and be intelligible. Now we have learned that for an understanding not only the elements but their interrelations as well are required.

Application of this above “put-together” analytical procedure depends on two conditions. .

The first is that interactions between “parts” be non-existent or weak enough to be neglected for certain research purposes. Only under this condition, can the parts be “work out”, actually, logically, and mathematically, and then be “put together”.

The second condition is that the relations describing the behaviour of parts be linear; only then is the condition of summativity given, i.e. an equation describing the behaviour of the total is of the same form as the equations describing the behaviour of the parts; partial processes can be superimposed to obtain the total process, etc. (Ludwig,1973)

These conditions are not fulfilled in the entities called systems. i.e. consisting of parts “in interaction”. The methodological problem of system theory, therefore, is to provide for problems which, compared with the analytical-summative ones of classical science, are of a more general nature. System analysis could result in port system integration.

## **1.8. System Integration**

System integration permits sharing of resources. Physical equipment, concepts, information, and skills may be shared as resources. (ADEDEJI, 1995)

System integration is now a major concern of many organisations.



System integration may include physical integration of technical components, objective integration of operations, conceptual integration of management processes, or a combination of any of those.

Systems integration involves the linking of components to form subsystems and the linking of subsystems and the linking of subsystems to form composite systems within a single department and /or across departments.

It facilitates the co-ordination of technical and managerial efforts to enhance organisational functions, reduce cost, save energy, improve productivity, and increase the utilisation of resources. Systems integration emphasises the identification and co-ordination of the interface requirements between the components in an integrated system.

The components and subsystems operate synergistically to optimise the performance of the total system.

Systems integration ensures that all performance goals are satisfied with a minimum expenditure of time and resources.

Integration can be achieved in several forms including the followings:

1. Dual-use integration:

This involves the use of a single component by separate subsystems to reduce both the initial cost and the operating cost during the life cycle.

2. Dynamic resource integration:

This involves integrating the resources flows of two normally separate subsystems so that the resources flow from one to or through the other minimise the total resource requirement in a project.

### 3. Restructuring of functions.

This involves the restructuring of functions and re-integration of subsystems to optimise costs when a new subsystem is introduced into the project environment. System integration is particularly important when introducing new technology into an existing system.

It involves co-ordinating new operations to coexist with existing operations, and it may require the adjustment of functions to permit sharing of resources, development of new policies to accommodate product integration, or realignment of managerial responsibilities.

It can affect both hardware and software components of an organisation. The following are guidelines and improvement questions relevant for systems integration:

- ◆ What are the unique characteristics of each component in the integrated system?
- ◆ How do the characteristics complement one another?
- ◆ What physical interfaces exist between the components?
- ◆ What data/information interfaces exist between the components?
- ◆ What ideological differences exist between the components?
- ◆ What are the data flow requirements for the components?
- ◆ What are the reporting requirements in the integrated system?
- ◆ Are there any hierarchical restrictions on the operations of the components of the integrated system?
- ◆ What are the internal and external factors expected to influence the integrated system?
- ◆ How can the performance of the integrated system be measured?
- ◆ What are the relative priorities assigned to each component of the integrated system?

- ◆ What are the strengths of the integrated system?
- ◆ What are the weaknesses of the integrated system?
- ◆ What resources are needed to keep the integrated system operating satisfactorily?
- ◆ Which section of the organisation will have primary responsibility for the operation of the integrated system?

Anyway, top level manager should arrange to find ways to reflect “why” and “how” and to plan for the future, who has the duty of keeping the performance of the port under constant review and of thinking ahead.

## Chapter 2: **System analysis of port in the general view**

System theory is not isolated, but corresponded to a trend in modern thinking.

### **2.1. System technology and its application in port**

There are quite a number of novel developments meet the needs of system theory. We may enumerate them in brief followings:

1. Cybernetics, based upon the principle of feedback or circular causal trains providing mechanisms for goal-seeking and self controlling behaviour.
2. Information theory, introducing the concept of information as a quality measurable by an expression isomorphic to negative entropy in physics, and developing the principles of its transmission.
3. Game theory analysing, in a novel mathematical frame-work, rational competition between two or more antagonists for maximum gain and minimum loss.
4. Decision theory, similarly analysing rational choices, within human organisations, based upon examination of a given situation and its possible outcomes.

5. Topology or relational mathematics, including non-metrical fields such as network and graph theory.
6. Factor analysis, i.e., isolation, by way of mathematical analysis, of factors in multi-variable phenomena in psychology or other fields.
7. General system theory in the narrow sense, trying to derive, from a general definition of “system” as a complex of interacting components, concepts characteristic of organisation, competition, finality, etc. , and to apply them to concrete phenomena.

While systems theory in the broad sense has the character of a basic science, it has its correlate in applied science, sometimes subsumed under the general name of systems science. Broadly speaking, the following fields can be distinguished:

Systems engineering, i.e. scientific planning, design, evaluation, and construction of man-machine systems.

Operations research, i.e. scientific control of existing systems of men, machines, materials, money, etc.

Human engineering, i.e. scientific adaptation of systems and especially machines in order to obtain maximum efficiency with minimum cost in money and other expenses.

There are a number of techniques for network analysis that permit complex problems in port to be analysed:

- Maximum/minimum flow networks
- Decision tree networks
- Flow graph models

- Mathematical techniques
- Simulation methods

These above technique used to concentrate a problem within a port, these kinds of system methods usage are just bound to a specific problem within a function, without consideration the whole system functions relationship in a whole port management view.

## 2.2. System analysing approaches

Actually, there are two possible ways or general methods in systems study:

Two main lines are readily distinguished.

1) One takes the whole as we find it, examines the various subsystems that occur in it-and then draws up statements about the regularities that have been observed to hold. This method is essentially empirical. It is a top-beginning method.

2) The second method is to start at the other end. Instead of studying whole system carefully, it goes to the other extreme, considers the set of all conceivable subsystems and then reduces the set to a more reasonable size. After study this, then go-up to a more general scope and position the previous study result within this. This is a bottom-beginning means.

It will easily be seen that all systems studies follow one or the other of these methods or a combination of both.

As a *whole system manager*, it is better to start with the first way, by top-to-bottom analysing, could easily control the implement level work from the whole system view.

As an *implement level manager*, the second way deserves consideration to be a beginning. .

Anyway, each of the approaches has its advantages as well as shortcomings. People should not just take one and desert the other. Only a good combination of these two ways of thinking could form a successful guidance for the whole port system work.

### **2.3. Port system major elements**

Using system thinking, we not just analyse separated part of the whole system, we analyse its internal state, the state of its surroundings, if it is possible, defines uniquely the next state the system will go to.

Port is a subsystem of the whole world trade system, and also a subsystem of logistics system. Port is open system and open system must interact with external entities in its environment. The parties have activities relating to port include the carriers, representing all modes of transport-handlers, documentaries, and financiers of cargo. In a large port, representatives of classification societies, of government regulatory agencies, of engine and equipment manufacturers, and the like are added to the numbers requiring the administrative attentions of port authority, and possibly accommodation on the port estate. Therefore port operation involves a large variety of activities performed by many different groups and individuals.

In this chapter, we will define the environment of port system by setting up system boundary.

### **2.4. Port system driving forces**

We will also describe what port system state is, what are inputs and outputs of port system and its subsystems, what are the relations between different functions within port.

Since physical flows, the financial flows and the administrative procedures are the main driving forces of the port business, we would draw a conclusion that:

*Physical flows, financial flows and information are the three main flows working through port.*

Port system model consists of inputs, such as land, labour, and capital, Outputs from the system include the movement of people and goods and improvement or deterioration of the physical environment. They could be divided into three flows:

Physical flows: consists of vehicles, pavements, tracks, rights-of-way, terminals and other manufactured or natural objects. In this dissertation, we mainly divide it as cargo flow and equipment/facility flow.

Financial flow: Apparently cash and capital flow.

Information: instruction from managers or report from implementation and documentation, so on.

The additional factors are also concerned, which are:

Activities: are the functions of port system, such as berthing, mooring, driving, traffic control, and so on. Here we mainly define them as functions or subsystems.



Human: individuals and groups of people who are involved with the physical and activity subsystems. Here we define it as outsiders or entity.

## 2.5. Tools of analysis

All systems---subsystems---are based upon five factors: input, store, processing, control and output. During our analyse process, we need some specific tools. Here we define:

 .....System boundary

Every system has a system boundary, which separates it from its environment. A system's environment is anything outside of its own boundaries with which it may interact or which may in some way influence the behaviour of the system. These things are often other “external” systems (external entities).

 -----System outsider. It means this entity is the outsider for a certain system or subsystem which we are dealing with.

 -----Information records, which mean this information will not just be used for once but also need to be saved and shared as resource. By using this, we could find what kind of information could be shared between which functions.

 -- Functions. Function of the system. Sometimes it also denotes the subsystem of current system.

 Cargo flow.

 Cash flow.

 Information flow

 Equipment flow.

X. Y-----in system function.

X-----Stands for the current system or subsystem

X. Y--- Stands for the Yth subsystem of X system.

By this tool, the structured system chart could be sketched later, after system analysis, we could find what is the main flow going between different functions.

## 2.6. Port system and subsystems structure

We define as followings according to port activities:

0:Port system

1: Operation system

1. 1 Cargo operation system

1. 2 Passenger operation system

1. 3 Other operation system

1. 3. 1 Construction and conservancy

1. 3. 2 Equipment and facilities maintenance

1. 3. 3 Pilotage

1. 3. 4 Ship/vehicle management

2: Financial and accounting system

2. 1 Budgeting

2. 2 Accounting'

2. 3 Financial analysis/decision supporting

2. 4 Audit

2. 5 Insurance

## 2. 6 Banking

### 3: Management

#### 3. 1 Decision-making

#### 3. 2 Planning

#### 3. 3 Security

#### 3. 4 Legal

##### 3. 4. 1 Contracts

##### 3. 4. 2 Negotiation

##### 3. 4. 3 Legal work

#### 3. 5 Personnel

##### 3. 5. 1 Personnel management

##### 3. 5. 2 Training

##### 3. 5. 3 Healthcare

##### 3. 5. 4 Benefits

##### 3. 5. 5 Union relations

#### 3. 6 Marketing

##### 3. 6. 1 Pricing

##### 3. 6. 2 Market research

##### 3. 6. 3 Public relations

#### 3. 7 Documentation

#### 3. 8 Services

#### 3. 9 Environment

Within cargo operation system, mainly physical cargo flows go through this system

Port organisation system: administration procedure and instructions or strategies work within it. Information flow is a significant feature of this system.

Port financial and investment system: mainly cash flow or financial flow going within this system

Port operation system: mainly cargo and equipment flows works.

Flow of information is a significant and dominant interrelation between all these subsystems.

## **2.7. 0-level system analysis**

In Figure 2-1: 0-level system analysis, we set up the boundary of port system and describe roughly its outsiders and relationships. Its main outsiders are shipping business and other organisations (government, bank, manufactures, suppliers, customs. etc.) and inland transportation. This reflects the main function of port: a node between sea transport and other transport.

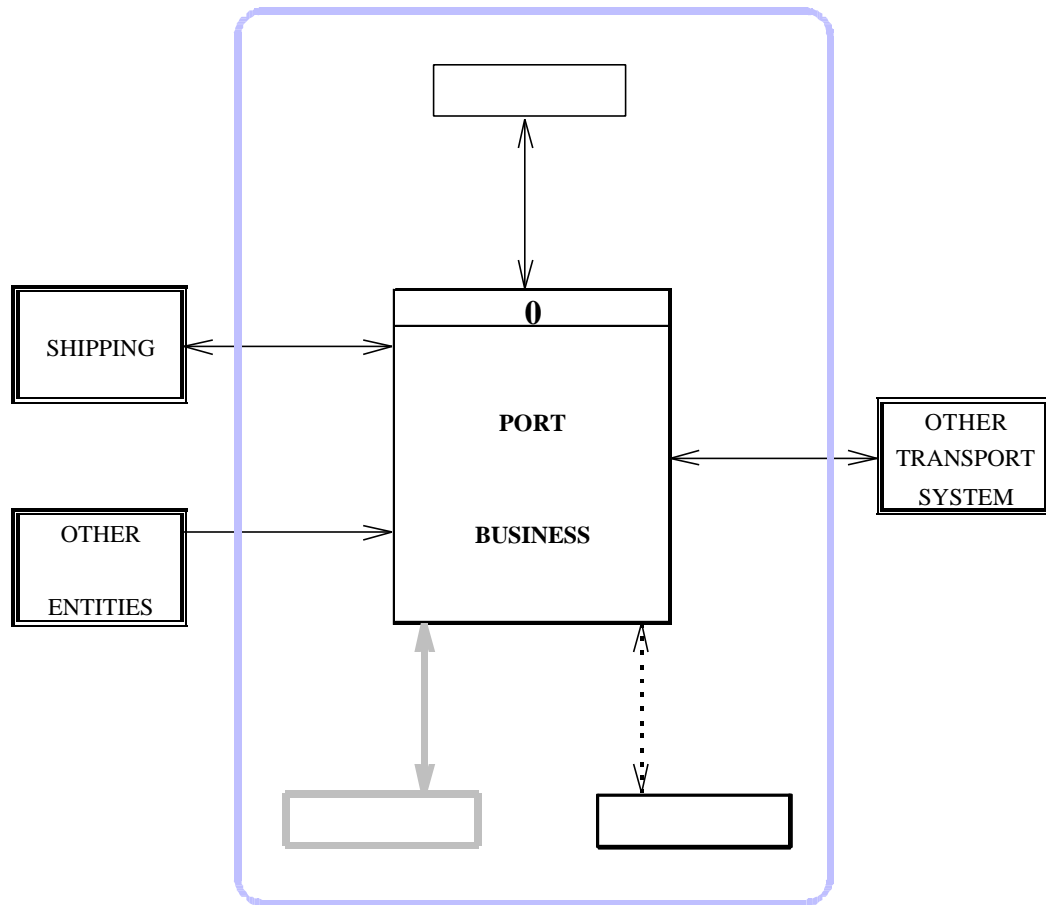

Figure 2-1: 0-level system analysis

## 2.8. 1-level system analysis

Under the above thinking, the author would like to describe port system in three main functions according to the different flows. (See Figure 2-2)

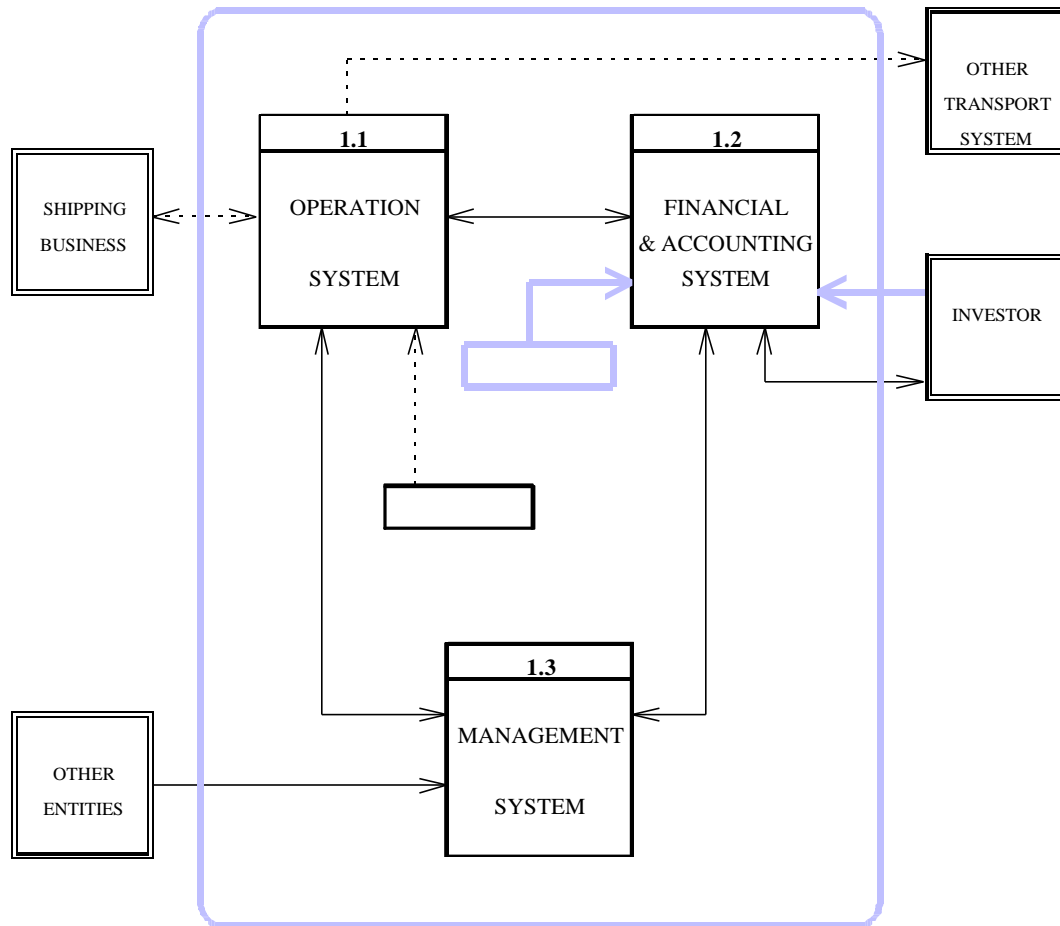

Figure 2-2 1-level system analysis

### 2.8.1. Management subsystem

The management of most ports in the world is vested in a port authority. The most striking feature of port administration in the major parts of the world is the diverse form of ownership adopted and the numerous ways in which responsibility for providing facilities and services have been delegated.

However, no matter how the organisation structure changes, the main driving forces of ports, that is physical, money, and information flows will still be the same. From the author's point of view, these are the basements for a general model of ports. That is why the Figure 2-2, the 1-level port system analysis figure was generated.

If we analyse this system further, combining 0-level, 1-level system analysis and system structure we made in this chapter, we could not only understand the port organisation hierarchy structure, but also could understand the relationships and their states and inputs and outputs. This is also the difference of this method from previous analysing tools.

### **2.8.2. Financial and accounting subsystem**

A thorough study of financial management to a port requires the modelling of the capital flows through the port entity, including the overall authority or administration. The major capital and cash flows through the port are fairly complex.

Capital and cash inflows and outflows often participate in internal feedback loops designed to assure both control and internal distribution. The method and type of financing used by a port will determine the scope of its operations and the size and type debt load the port can carry. As a result, they are the most important factors influencing a port's investment decisions, and consequently, its financial strategies, the expected returns from capital investments, its growth rate, and the like that determine future financing available.

The decisions of port are heavily dependent on and influenced by the flow of capital through port activities.

### **2.8.3. Operation subsystem**

Patterns of cargo flows are changed quickly, multi-modal transportation has also given birth to a new way of operation structure.

We admit that ports provide a fairly wide range of different services. There are, in fact, not only but several markets for their products. The demand for the bulk dry cargo shipment market is different from the carriage of bulk liquid cargoes. This in turn requires differing port facilities not only in terms of berths, but also in distribution arrangements. Likewise, the demand for containerised shipments is different from the passenger market involving a cruise liner, or the motorist travelling on a car ferry service. Again, such differing shipping services need the appropriate separate berthing facilities and “back-up” resources including customs, immigration, distribution arrangements, and so on.

However, whatever the changes are, port will still maintain its role as a linkage between sea transport and different transportation modes. What are changing are only cargo flows and value-added (which bellows financial flows), under this prerequisite, we are able to set up a relatively static and flexible rough image of operation subsystem based on its operation activities.

We just like a painter to draw a picture, first we need to make a sketch, then we begin with painting details. In next chapter, we will pay more attention on this part, especially on cargo operation subsystem.



## Chapter 3:

# Cargo operation system

Because operation in a port is an apparently confused mixture of a variety of different activities--cargoes of many types moving in all directions and being handled by different gangs and equipment, a good manager has to adopt a very systematic approach if he is to grasp what is going on--, and, especially, what is going wrong.

We must recognise the component parts of the berth operation and study them as systematic structured activities.

In previous chapter, we have discussed about the overall systematic structure of port system, now in this chapter we will analyse the subsystem of 1:operation system, 1.1 cargo operation system

### 3.1. Cargo moving routes in port

There are four basic components or subsystems of cargo operation:

- The ship operation
- The quay operation
- The storage operation
- The receipt/delivery operation

They are closely related activities and should always be considered as parts of one overall operation. However, for making these four subsystems co-operate efficiently, planning is a necessary pre-requisite.

Cargo moving across the quay to or from the ship operation has a choice of 2 routes: direct route and indirect route.

*Indirect route:*

Cargo following the indirect route is handled by the second stage of the berth operation, the quay transfer operation: movement of cargo between a storage area and the quayside. It involves not only the transfer itself but also sorting to mark and separation. As in the ship operation, manual or mechanical handling techniques may be used in the quay transfer operation.

*Direct route:*

Receipt/Delivery (Distribution) operation forms the second operation in loading/unloading sequence, following on and dovetailing with the ship operation, as cargo is lifted by the hook directly to road or rail vehicles or overside, vice versa.

From the UNCTAD chart: figure: 3-1. The arrows in the figure show two routes of cargo movement.

Since the Receipt/Delivery (Distribution) operation in direct delivery takes place on the quay apron (or on a barge alongside), bypassing Quay transfer and Storage, it might be the ideal route---cargo passes more rapidly through the port and fewer port facilities are needed.

However,  
 nowadays,  
 because of logistic  
 management, some  
 customers use port  
 as a distribution  
 and processing  
 accommodation  
 point in their  
 production  
 procedures and  
 indirect route may take its advantages in this point of view.

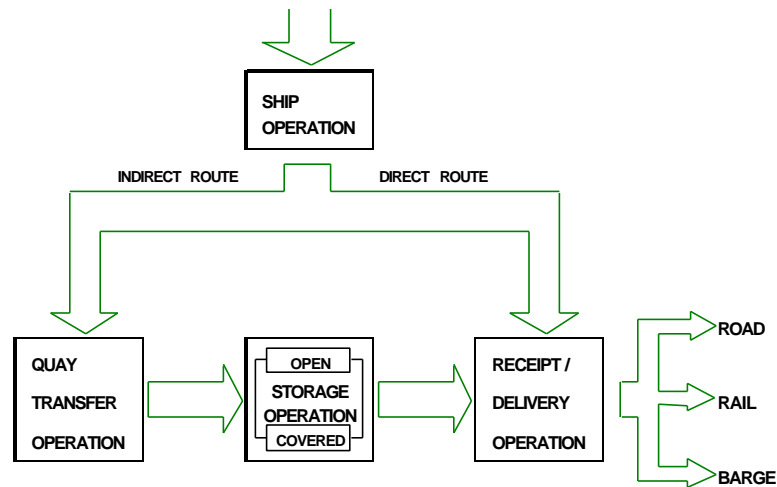

Figure 3-1

## 3.2. Cargo operation subsystem structure

Based on the activities of cargo operation, we construct this subsystem in following structure:

### 1. 1 Cargo operation:

#### 1. 1. 1 Cargo operation planning

##### 1.1.1.1 Pre-arrival planning

###### 1. 1. 1. 1 Berth allocation

###### 1. 1. 1. 2 Resources allocation

###### 1. 1. 1. 3 Estimating operation time.

##### 1.1.1.2 Work scheduling

##### 1.1.1.3 Performance review /measurement

#### 1. 1. 2 Ship operation

##### 1. 1. 2. 1 Organising

###### 1. 1. 2. 1. 1 General supervision (making hatch list)

- 1. 1. 2. 1. 2 Tallying
- 1. 1. 2. 1. 3 Safety
- 1. 1. 2. 2 Loading
  - 1. 1. 2. 2. 1 Preparation
  - 1. 1. 2. 2. 2 Lifting
  - 1. 1. 2. 2. 3 Unhooking and cargo stowage
  - 1. 1. 2. 2. 4 Hook return to the quay
- 1. 1. 2. 3 Unloading
  - 1. 1. 2. 3. 1. Preparation and hooking on of cargo in the hold
  - 1. 1. 2. 3. 2 Lifting of the cargo to the quay
  - 1. 1. 2. 3. 3 Landing of cargo and unhooking
  - 1. 1. 2. 3. 4 Return of hook to hold
- 1. 1. 3 Quay transfer operation
  - 1. 1. 3. 1 Cargo loading transfer
    - 1. 1. 3. 1. 1 Pick-up of cargo
    - 1. 1. 3. 1. 2. Transfer to quay apron
    - 1. 1. 3. 1. 3 Landing of cargo under the hook
    - 1. 1. 3. 1. 4 Return to the storage area
  - 1.1.3.2 Cargo unloading transfer
    - 1.1.3.2.1 Pick-up of cargo
    - 1.1.3.2.2. Transfer to storage
    - 1.1.3.2.3 Landing/stacking
    - 1.1.3.2.4 Return to quayside
- 1. 1. 4 Storage operation
  - 1. 1. 4. 1 Planning storage operation
  - 1. 1. 4. 2 Supervision storage operation
  - 1. 1. 4. 3 Storage
    - 1. 1. 4. 3. 1. Transit storage(short-term)
    - 1. 1. 4. 3. 2 Long-term Storage
    - 1. 1. 4. 3. 3. Re-processing (logistic)

- 1. 1. 5 Receipt/delivery
  - 1. 1. 5. 1 Co-ordination
  - 1. 1. 5. 2 Positioning
  - 1. 1. 5. 3 Loading/Discharging
  - 1. 1. 5. 4 Dispatch

Each one above stands for a small subsystem, and it has its own boundary, flows and information, which may have interaction with other parent-system or subsystems.

The author analysed this subsystem and use Figure 3-2 to show the organisation and flows relations. In this figure, we express port cargo operation subsystem into five even further subsystems according the above structure we have constructed:

- 1.1.1: Cargo operation planning
- 1.1.2: Ship operation
- 1.1.3: Quay transfer operation
- 1.1.4: Storage operation
- 1.1.5: Receipt/delivery (Distribution) operation.

From figure 3-2, we find:

1.1.1: Cargo operation planning subsystem gets application from ship or its agent for the ship's arrival. Then this subsystem will organise the operation by communication with other subsystems and generate plans, which will help other subsystems work. This is understandable by the lines denoting information flows between 1.1.1: Cargo operation planning and other four subsystems within this 1.1: Cargo operation system.

The dotted line linking outsider: Shipping with 1.1.2: Ship operation stands for the cargo movement under the actions of these two subsystems. The two

direction arrows indicate that the cargo either could move via 1.1.2 Ship operation towards shipping (Loading) or from Shipping to 1.1.2 Ship operation(Unloading).

Since there are two routes of cargo movement, 1.1.3: Quay transfer operation and 1.1.5: Receipt/Delivery (Distribution) subsystem will correspond to these two route cargo movements, respectively. The dotted-line box beside subsystem: 1.1.4 Storage means that there are cargo stores involved in this function or subsystem running.

Lines in this figure: 3-2 implicate information going between each subsystems within 1.1: Cargo operation system or with outsiders. Each of them may contain more than one piece of information and is more complicated than just simple cargo movement.

Now we analyse the subsystems in 1.1: Cargo operation system one by one.

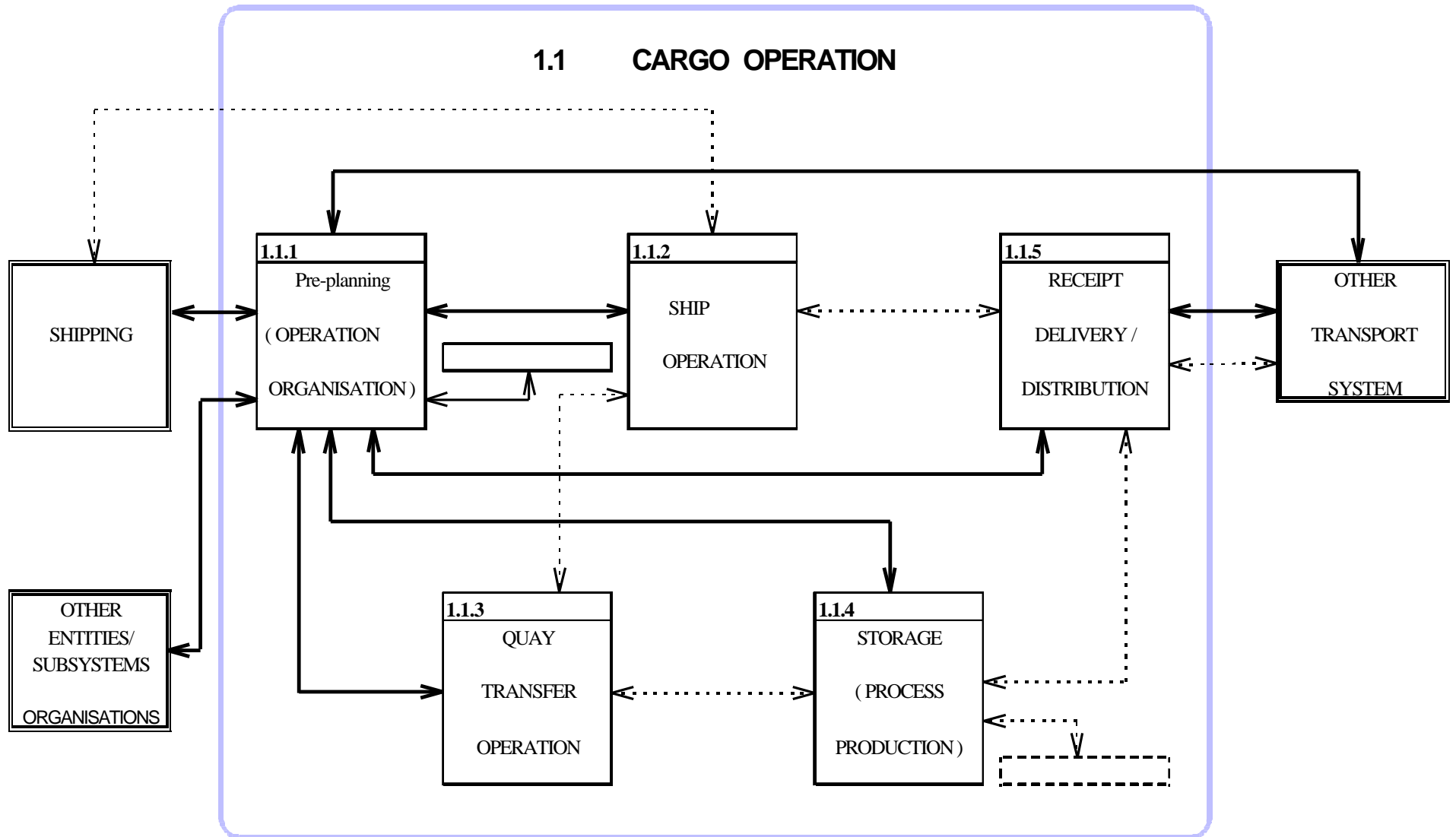

Figure 3-2

### 3.3. 1.1.1: Cargo operation planning

Managing a modern general cargo operation, with its complex, varied and continually changing activities, demands a systematic and comprehensive approach to operations planning. Detail planning is essential to ensure the proper allocation of resources and the effective co-ordinations outside the port. No matter how well traffic and operation managers undertake their day-to-day control and supervisory functions, without a systematic planning, it is impossible to achieve a very effective, smooth, cost-effective and balanced flow of cargo operated. System approach is an essential for cargo operation planning.

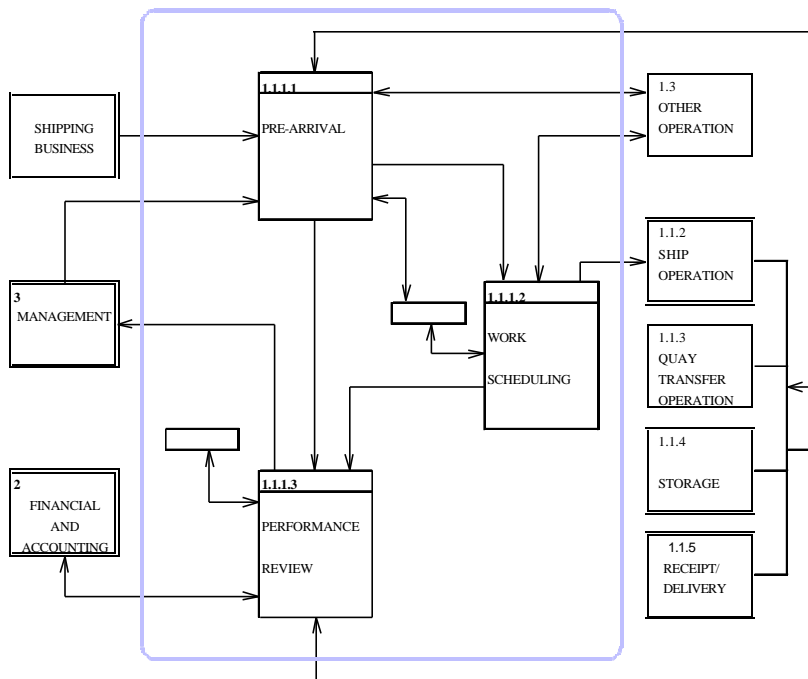

Figure 3-3 CARGO OPERATION PLANNING

Operation planning is different from some plan task of a long-term nature, which is the responsibility of senior manager, it is a plan that keeps day-to-day operations running smoothly.

smoothly.

Operations planning is of short-term and itself performed over different time-scales, ranging from a few days or even a week or two, at one extreme, to daily shift planning



at the other. It also involves a variety of activities, from allocating ships to berths to controlling the arrival of inland transport in the port.

UNCTAD IPP 1 has divided operations planning into three principal groups of activities.

- *Pre-arrival planning takes place before the vessel arrives in port.*
- *Work scheduling involves preparations for the next shift or day, when the vessel is at berth.*
- *Performance review is a 'post-mortem' on the quality of service provided on a vessel's call (or over a longer period) and is completed after the vessel has departed.*

### **3.3.1. 1.1.1.1 Pre-arrival planning**

Pre-arrival planning (see figure 3-3) is the first, and in many ways the most important, of the steps in operations planning. Pre-arrival planning has three main tasks: Berth allocation; Resource allocation; Estimate operating times.

Pre-arrival planning is designed to help the planning of the organisation of berth operations to achieve the highest possible productivity and the most efficient allocation of berth resources, to reduce to a minimum ship's time in port. It starts well before a vessel arrives at berth, and carrying out this phase of planning effectively is the best guarantee of a smooth and efficient cargo-handling operation.

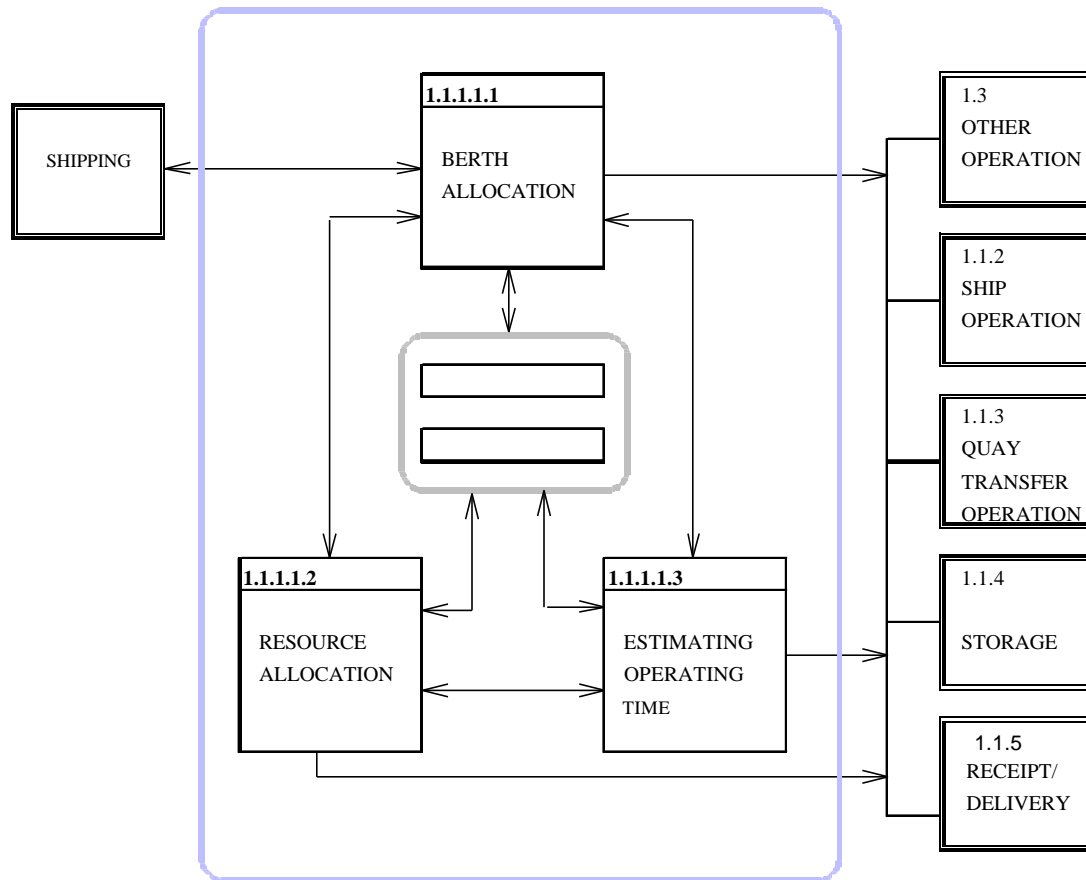

**Figure 3-4 1.1.1.1 PRE-ARRIVAL PLANNING**

### 3.3.2. 1.1.1.2 Work scheduling

It is shift-by-shift detailed planning of operations when the vessel is alongside the berth, designed to achieve the highest possible Ship output and the minimum of delays. The basic tool of work scheduling is a form. It facilitates the operator to be prepared to adjust work schedule by taking on-the spot supervision decision.

### **3.3.3. 1.1.1.3 Performance review**

After loading/unloading and other operation activities have been done, performance review task should be taken for not only concerning one ship's call but also for previous different period of times, such as week, month or year. Performance review is measurement of port performance and planning. It allows manager to identify problems and weaknesses, eventually to take actions to remove them. It is a tool of control.

Collecting data and provide indicators needed are its main functions, its inputs is from both financial subsystem (cost/earning) and other four cargo operation subsystems: ship operation, quay transfer operation, storage and receipt/delivery(distribution) systems and outputs are to organisation, financial and cargo operation subsystems for supervision or appraisal.

### **3.4. 1.1.2 Ship operation**

The ship operation covers the movement of cargo between the quayside and the vessel's hold, or vice versa. It involves preparation of cargo for the lift, the crane or the derrick operation, and release and disposal of the cargo after the lift. In modern technology, of course, the cargo may be handled through ship's doors, by ro-ro ramps, conveyor belts and so on.

The ship operation is often referred to as the dominant operation. Because every item of cargo, whatever its route through the ship operation, and the rate of handling here governs to a large extent the performance of the rest of the berth operation. The way of supervision the ship operation is a key factor in the performance of the berth operation as a whole. A sound analysis of ship operation is essential.

We analyse 1.1.2 Ship operation in systematic way, then we get figure:

The whole ship operation has three subsystems or functions: organising, loading and discharging.

From subsystem: 1. 1. 1 cargo operation planning or shipping company, 1.1.2 Ship operation subsystem gets the information about the arriving ship, which include the ship's type and cargo type, and also from 1. 1. 1: cargo operation planning, it gets the instruction, so for this function its output should be hatch list, statistical figures and safe cargo movement.

In figure 3-, we also could find there are six system inputs and outputs of 1.1.2 Ship operation system. These inputs and outputs are from/to:

- 1.1.3 Quay transfer operation
- 1.1.5 Receipt/Delivery (Distribution)
- Outsider: ship

According to the activities of ship operation, since the sequence is repeated again and again, it is often referred as Hook Cycle. Figure: 3-6 and figure 3-7 express the subsystems of ship operation: 1.1.2.2 loading and 1.1.2.3 unloading. The relations are clearly showed.

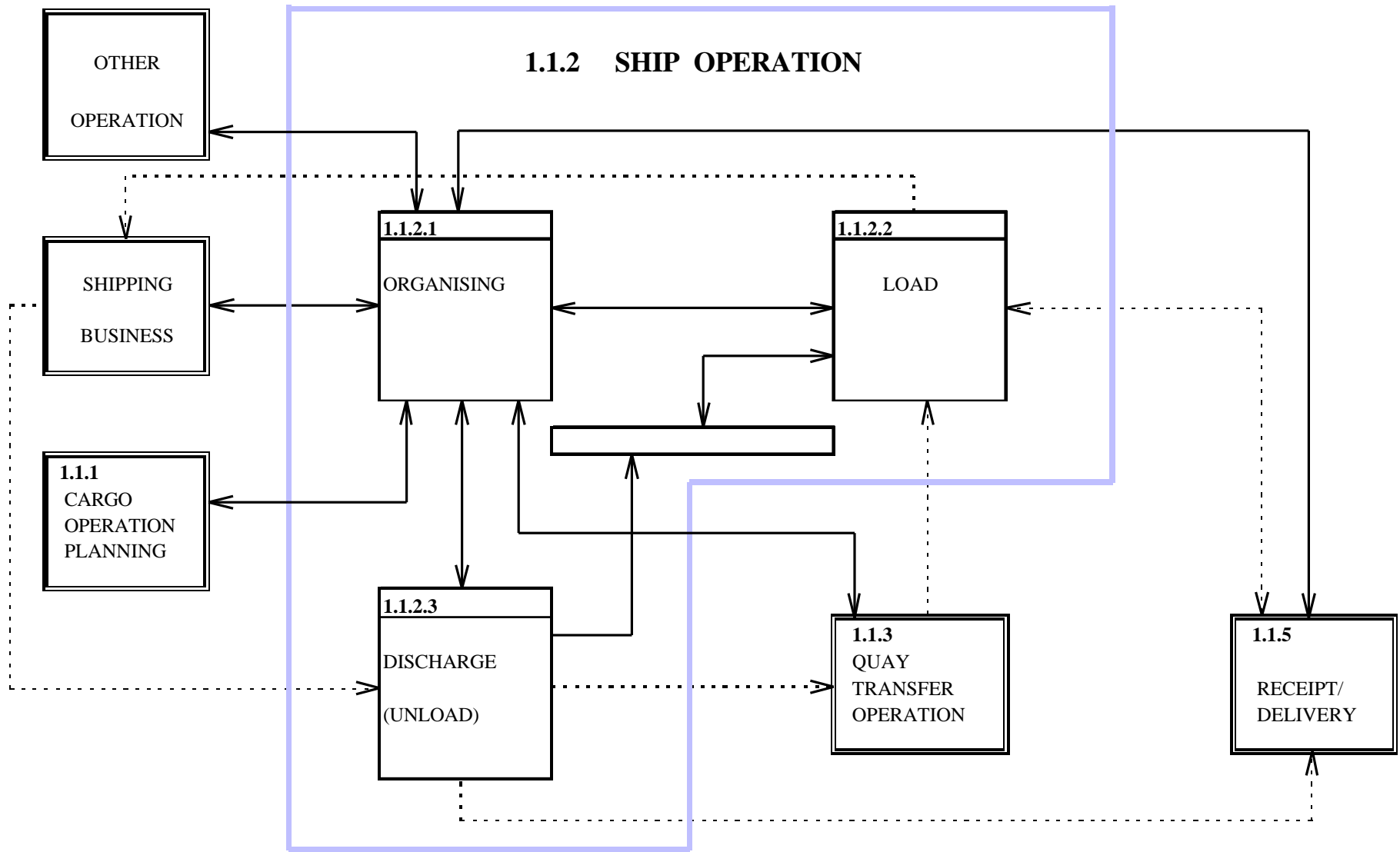
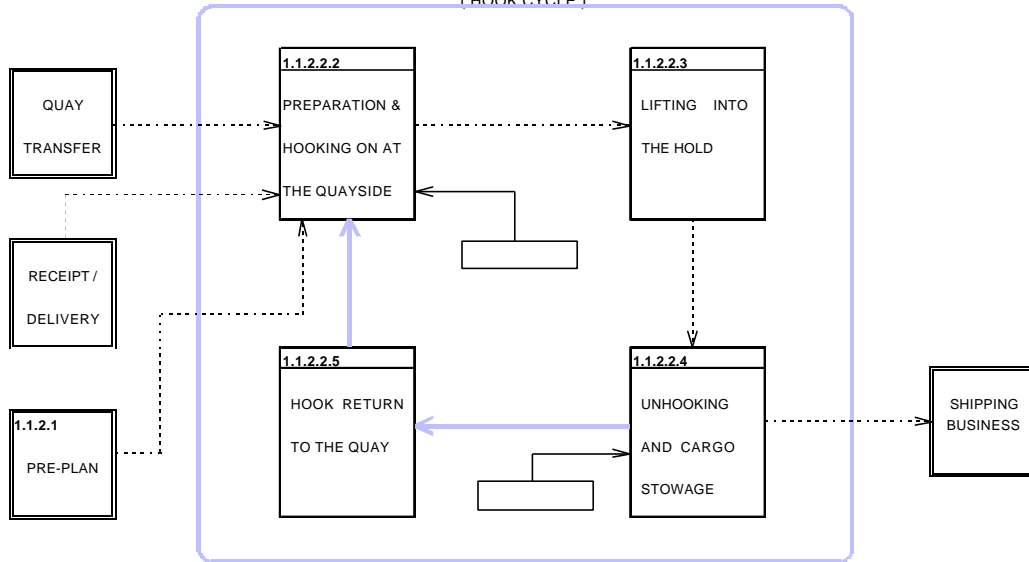
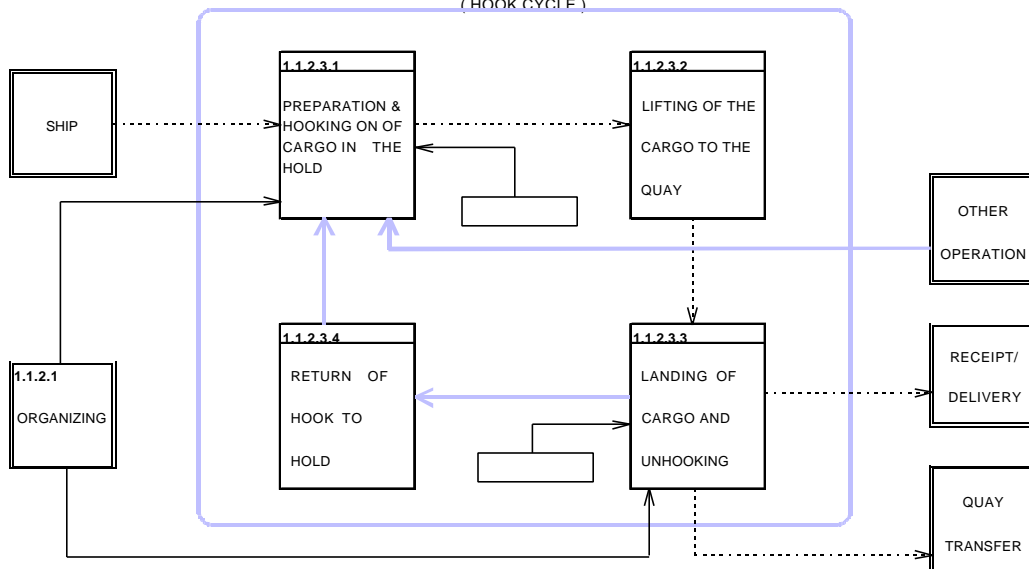

Figure 3-5

**Figure 3-6 1.1.2.2 CARGO LOADING (HOOK CYCLE)**



**Figure 3-7 1.1.2.3 CARGO DISCHARGE (HOOK CYCLE)**



1.1.2 Ship operation: loading /unloading

### 3.5. Quay transfer operation

The quay transfer operation links shipboard activities with port's storage areas, and occupies a very important position for indirectly routed cargoes. Its particular significance is as a regulator of the ship operation; unless quay transfer is efficiently organised, it can cause delays to the hook in the discharge operation or 'starvation' of the hook in loading operations.

Quay transfer operation also acts as a Cycle.

Figure 3-8 1.1.3 QUAY TRANSFER OPERATION

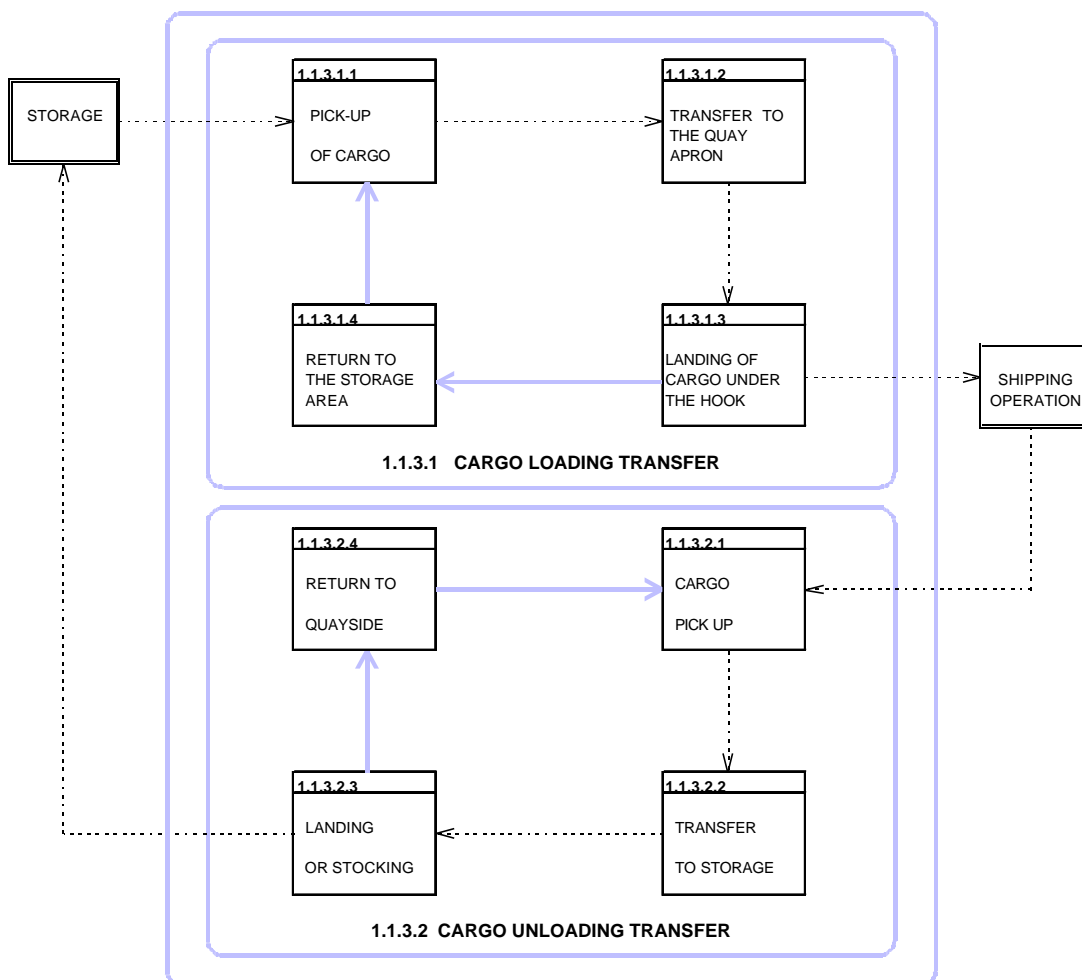

In the case of cargo discharge:

- 1. Cargo pick-up from where it has been landed by the hook on the quay apron;*
- 2. Transfer of the cargo from the quayside to the storage area;*
- 3. Landing or stacking of the cargo in its place of storage;*
- 4. Return of the equipment to the quayside, to complete the cycle.*

For cargo loading:

- 1. Pickup of cargo from storage;*
- 2. Transfer to the quay apron;*
- 3. Landing of cargo under the hook;*
- 4. Return to the storage area.*

Sensible allocation of men and equipment, which is done in cargo operation planning, enable quay transfer operation keep up with the output of the ship operation.



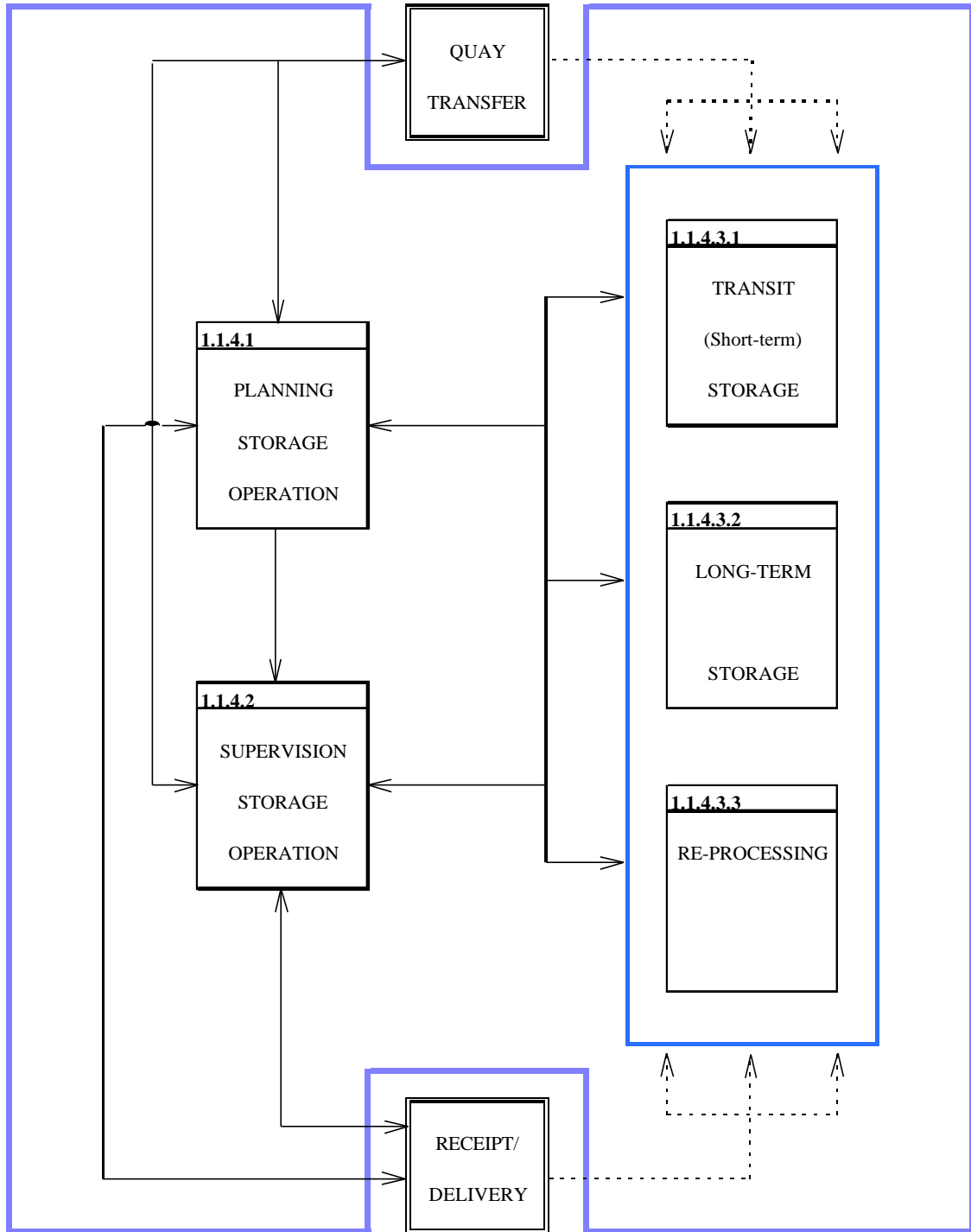

Figure 3-9 1.1.4 STORAGE OPERATION

### **3.6. 1.1.4 Storage**

Storage is the third stage of cargo operation in port. It is one kind of inland operation which include cargo processing, interfacing transportation modes, traffic control, and short -term management of cargo.

Originally, storage mainly involves transferring, sorting, inspecting, stacking, and discharging cargo according to a storage layout plan. The necessary equipment varies with the type of cargo. As logistic development, cargo processing takes more portions in storage operation than before.

We speak of open and covered storage (yards and sheds) or short-term and long-term storage. (See figure: 3-9).

Cargo storage is of three major types in terms of time scale: short term, long term and specialised. Or people may speak of indoor or outdoor, depending on the type and volume of cargo and the length of time the cargo has to be in the port, or the kind of activities required to forward it to its destination.

Short-term storage is usually for transient cargo that is awaiting distribution, inland, or marine transportation, or the remote long-term storage. For many kinds of cargo, short-term storage has been eliminated, and cargo is moved directly from the ship to long-term storage within or outside the port.

Long term storage is usually a buffer storage, from which the cargo is consumed. In some cases the same facilities are used for short and long term storage, or the two are distinguished.

Specialised storage is constructed for specific kinds of cargo; most specialised storage may be classified as long-term storage, for example, storage for refrigerated cargo, liquid cargo, bulk cargo, hazardous cargo and the like. In most cases specialised storage will be a part of specialised terminals, and here we put this function in re-processing subsystem.

### 3.7. 1.1.5 Receipt/Delivery (Distribution)

The final stage in the berth operation, as far as import cargo is concerned (the first one for export, of course), is the receipt/delivery operation. It is the movement of cargo

from its storage position to dispatch bays or delivery points and its handling to road, rail or inland waterway carriers, with all the necessary documentation and customs procedures.

**Figure 3-10 1.1.5 RECEIPT / DELIVERY OPERATION**

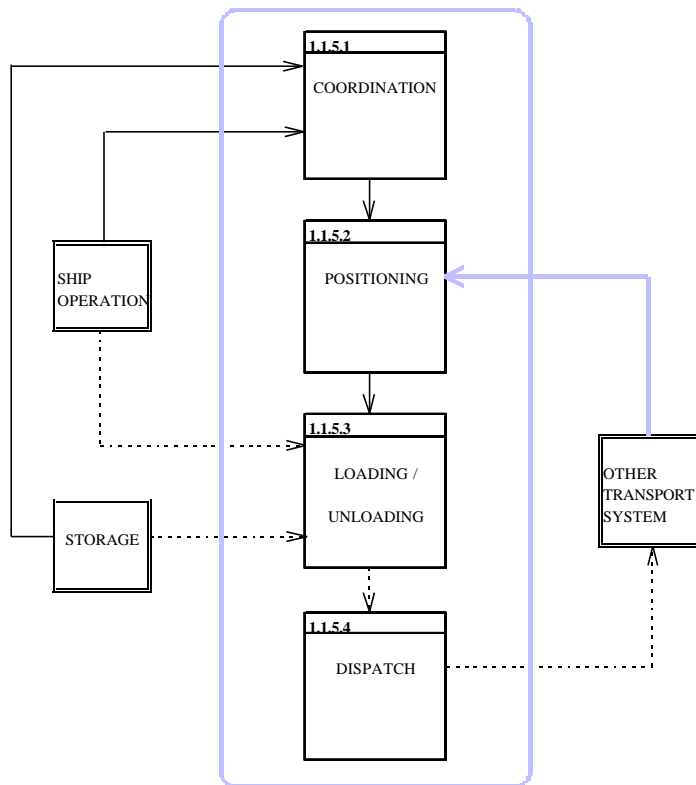

For cargo following the direct route, it forms the second operation in a discharge sequence, following on and dovetailing with the ship operation, as cargo lifted by the hook directly to

road or rail vehicles or overside to barges.

Whether cargo follows the Direct or Indirect Route through the port, the Receipt/Delivery Operation consists of a sequence of three activities: (1) Positioning, (2) Loading/Unloading, and (3) Dispatch.

For export cargo:

1. The transport vehicle is called forward to a position alongside the ship, preferably next to the hatch into which the cargo is to be loaded and, ideally, directly under the ship's hook.
2. The cargo is secured to the lifting gear and loaded into the ship.
3. The empty vehicle is moved quickly away from the quayside to a location where it can be prepared for departure and where all documentary procedures can be completed before it leaves the port.

For import cargo following the indirect route:

1. The calling of the wagons to go to the appropriate delivery bay or section, in the right order and the correct condition for receiving the cargo.
2. The loading of the cargo into the wagons;
3. Shunting of the wagons away to a marshalling yard for completion of documentary procedures before dispatch of the wagons from the port.

The Receipt/Delivery operation quite clearly demands a great deal of complex organisation. It is essential to have a properly worked-out system to handle it.

Only good management and supervision of procedures will ensure that the receipt/delivery operation does not present a barrier to the free flow of cargo into and out of the berth.

From all above analysis of 1.1 cargo operation system, we have got an idea how this system works and its interaction within or with outside parts of works. Next chapter we will see how system idea takes place in port management, especially for supporting whole port decision.

## Chapter 4

### **System vision of manager: cases**

System approach simply states that all functions or activities need to be understood in terms of how they affect, and are affected by, other elements and activities with which they interact. Without considering the impact of decision on the whole system view, a less efficient result may occur, on the other hand, a systematic decision will also be able to lead to a terrific success. Here the Hewlett-Packard's distribution of its production has given an evidence for system approach's effectiveness.

#### **4.1. Case 1: Hewlett-Packard's Systems Approach in Distribution system**

*Hewlett-Packard (HP) is a leading global supplier of computer printers. It has over \$3 billion invested in inventory worldwide. HP has a division located in Vancouver, Washington, which manufactures and distributes the Deskjet Plus worldwide. It has three distribution centres, one each in North America, Europe, and Asia.*

*HP faced a situation where high inventories of printers, approximately seven weeks' worth, were required to meet their 98 percent service goal in Europe. High inventories were required in part because each country has unique power cord and transformer requirements, and needs the proper language manual. Initially, the "differentiation" of the printers to meet the*

*needs of the local market was done at the Vancouver facility. HP apparently faced the prospect of high inventory costs or reduced customer service levels, neither of which was an acceptable option.*

*The management at the Vancouver site considered many options for reducing inventory while maintaining customer service. They first worked on improving the logistics system by reducing delivery variability. They considered faster shipping modes, such as air, to reduce transit inventory, and inventory held to cover lead times. That alternative proved too costly.*

*However, by looking at the entire system as a whole, HP was able to develop a better solution. It could delay the differentiation of printer power sources and manuals until firm orders were received. This allowed HP to reduce inventory to five weeks while maintaining 98 percent service levels. This saved over \$30 million annually. In addition, transportation dropped by several million dollars because generic printers can be shipped in larger volumes than printers specific to particular country. Because HP viewed the system as a whole and understood the interactions, they were able to develop this innovative logistical solution.*

The above story is a good example of how system approach succeeds in business work. Of course, system thinking is also feasible in port running.

We have mentioned that analysing a system will not only know the system present state, but also should see its future. In fact, by this analysing, we could know what is the main problem now, and if it is possible, what is the next problem for the system. That is we will know what is the bottleneck in the system, as long as the bottleneck could be enlarged, then the system could work smoothly.

In different time for the system, has different bottleneck. If the port has congestion, the cargo operation maybe is the bottleneck and the port manager needs to concentrate on this subsystem. If this problem is solved by either enlarging the port capacity or improvement of port productivity, may be next situation is that the port lacks of cargo, and port marketing becomes the main subsystem and should be concerned.

If even the efficiency has already reached almost its limitation, the manager still continuously caring too much about the berth efficiency instead of attracting cargo, then the port will not work well consequently.

Many successful ports actually in the right time have made the right decision because they have taken a whole point of view, system view, initiated the ports right function to work on the exactly point. Just for this reason, I would say these managers know more about system than the system expertise's on this particular case because they are not limiting system technique for solving practical problems, which would not have so much influence as big decisions for port future development.

In fact, system theory is not just suitable for practical questions. The system thinking does have worked in the decision-making procedures. Some managers just have used the system view and succeeded even they did not recognised it.

Let us take Port of Hamburg and see how systematic approach pays back?



**Figure. 4-1: THE STATE OF HAMBURG AND ITS PORT**

*Organisational Structure*

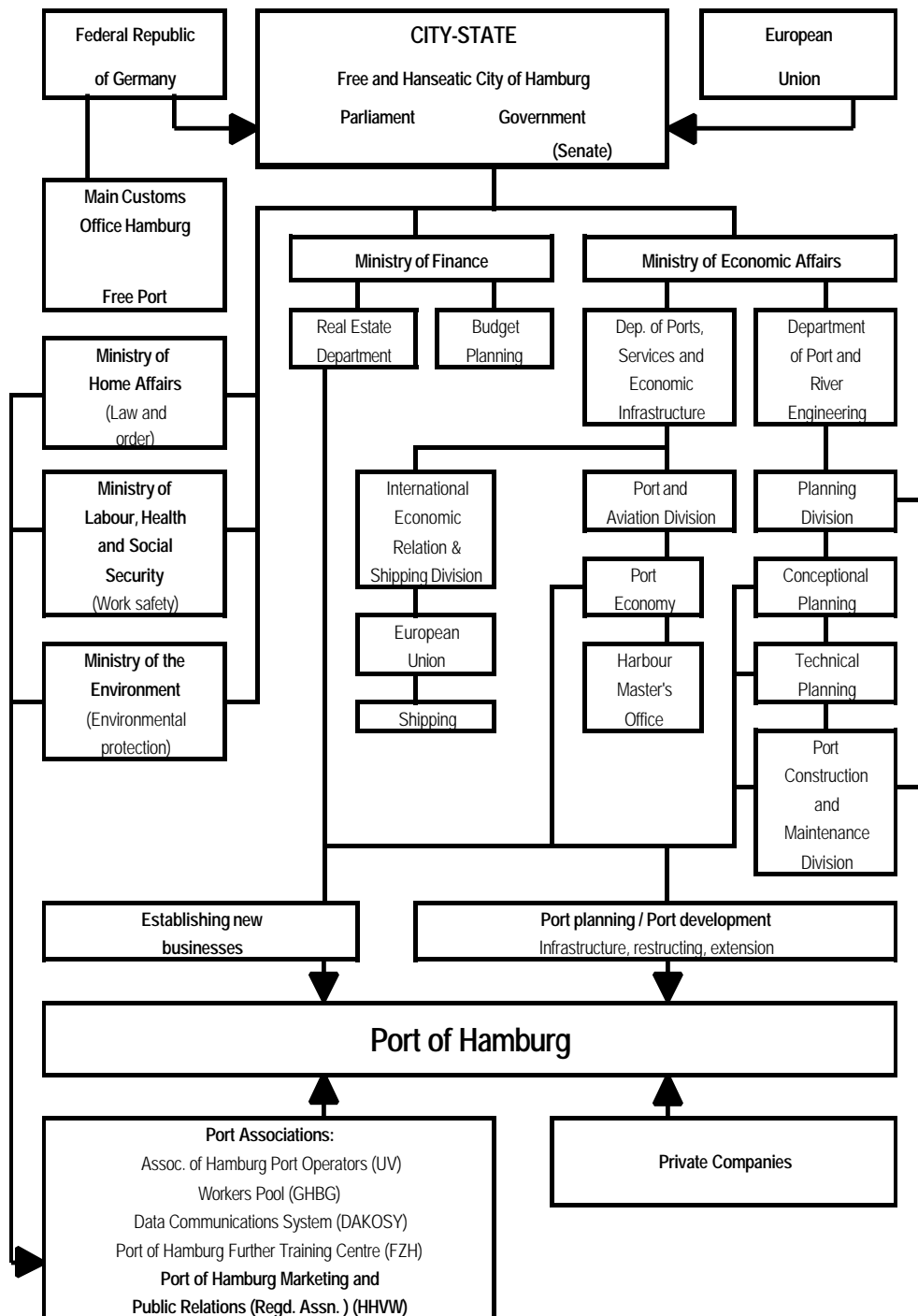

## 4.2. Case 2: System vision of Port of Hamburg's Manager

Why port of Hamburg has achieved its position today? First of all, they think in whole view instead of just chasing profits.

Dr. Hans Ludwig Beth, chairman of Port of Hamburg Marketing and public Relations association said:

*What makes the port of Hamburg unique? Our geographical location? Our outstanding rail connections to eastern Europe? Our extensive feeder network? Our high-frequency services to the Far east? Our vital role as an inter-modal hub? Our ability to provide a truly comprehensive service? The real choice we offer our customers? Our potential for growth?*

*In fact, it is all these things together - and a few more besides. there are not many ports in the world, and it is difficult to think of any in Europe, which can provide quite the range of services customers find at Hamburg. Many ports today are restricting their activities to the most profitable ventures, closing down operations which do not make money, and thus depriving the customer of choice. At Hamburg, we believe customer choice should be paramount.*

They also said:

*In today's fast expanding global market, it is those places which have always had an international outlook that are going to be successful”*

Based upon the main subsystem we analysed in Chapter 2, we will find the model is still feasible for Hamburg, see Figure 4-1, Three main subsystem corresponding to its activities:

The port has Ministry of Economic Affairs: its operation subsystem; Ministry of Finance: Financial subsystem; Other ministries (Home affairs, Labour, Health...): Management subsystem.

Actually, in above decision, they already have a vision for the development of port, not just, restricted themselves on the profits. This is a system wholly view rather than a limited small part of the whole, such as a profit, it is only one of the output of the system. in a short term, maybe the profit-concern way is better than the customer choice one, however, in the long run, the last one could be more beneficial, since this alternative including more than profits, just as we have analysed before, the first just considered the cash flow of the port system, of course we should admitted that this is also a measurement of system effectiveness, but the later one has contents of all the three flows information instead of just cash flow. See Figure:4-2 , which shows the relationships and difference of these two alternatives.

Customer is the outsider of the port system and customer is also the sources of profit, by moving cargoes or processing goods from customer, ports get their profit which stands for the added value. The relationships between port and customer are also in three categories which we have already analysed before, 3:Cargo flows; 2:Cash flow; 4:Information flow.

Profit equals earning minus cost, it is only cash flow could reflect it. From the figure, we can see::

$$\text{Profit} = (6): \text{cash flow} - \text{cost}$$

Profit has a much more restricted implication than the flows going between the Hamburg Port and its customers.

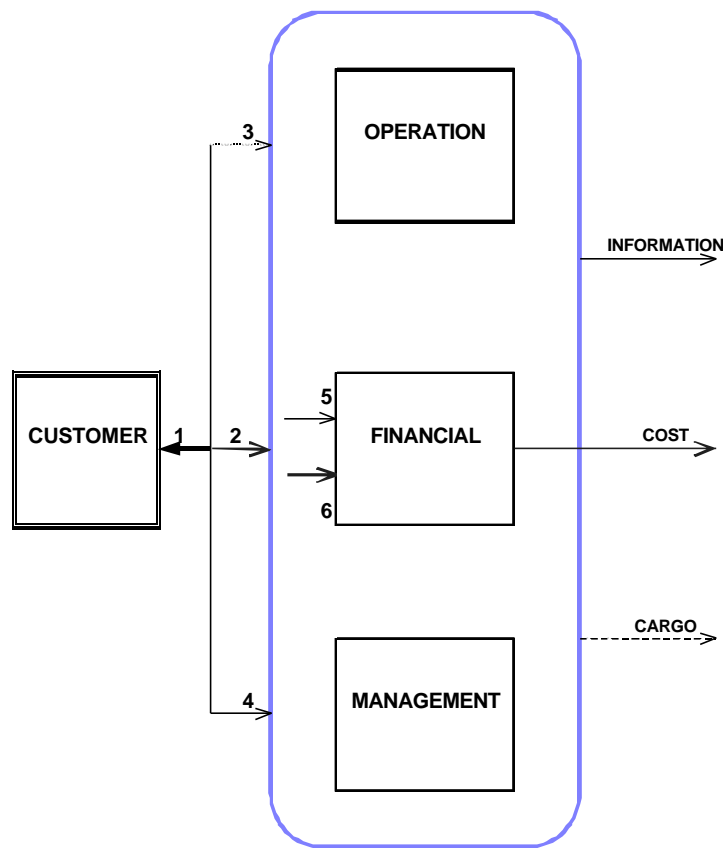

Figure. 4-2

flows and all functions are related. Summarily, customer choice has a more broad view than profit choice.

Attracting customer means getting more inputs of system: cargo flows, cash flows and information flow, which in turn will generate more outputs via system functions, provided the system in normal working status.

Consequently, the system will enlarge its boundary and the both the system and its subsystem will have larger scale than before. This is the successful secret of Port of Hamburg in a general system view.

For the profit choice, from the figure, it involves input 6: cash input, output: cost and function: Financial, even function: Financial acts simultaneously and co-ordinating with function: Operation and function Management. Customer choice includes inputs: 1,2,3,4 standing for three main kinds of

### 4.3. Assumption

Are the other ports are the same? Not exactly, at this particular case, the main function of Hamburg port is its management subsystem, making decisions between different options for the future objective of port.

Assuming if port of Hamburg has not enough investment capital at the demanding time, what would happen? If this situation happens, of course, provided that the other conditions are all the same, then the main initiated subsystem/function should be 2:Financial and accounting subsystem--get money to invest in port facilities in order to meet customer's needs.

Furthermore, if the port could not get its fund, from system view, this time the main idea should be that the 1:Operation subsystem acts efficiently to cut cost, maybe in this time, the profit choice is the best.

Definitely, in every situation, meanwhile, all the subsystems act together instead of working independently without connection with other subsystems, but the way of working are different. The most active subsystem is changing in different period.

Assuming at that time Hamburg port has found the customer should be the main concern, but Hamburg port could not be able to realise their target: to meet the needs of customer, then what the port system manager should do? From the 1-level system analysis chart of port, figure 2-2, we could give a general estimate according its subsystems or functions:

- 1: If port has not enough money to invest its facilities in order to invest its facilities in order to meet customer choice, then 2: Financial and accounting

subsystem should work as the main activated function, it will get more input from investor to expand the port service.

2: If the main problem is the port is not efficient in its operation, which leads to waste of resources and delays of ships, then the most active subsystem we concentrated should be operation subsystem.

3: If both above two options are not so blameable, and the main problem of port becomes:

- Maybe some vital decisions need to be made, or may the objective of port is to be changed.

- Or management style of port may is no longer able to catch up with the developing pace of port development and port performance, then the port manager should initiate management subsystem and management style, usually, this time a big change within port will happen, it is called as a reformation.

#### **4.4. Remarks**

How to measure a system? Why system thoughts lead success? As we know, some indicators, such as port productivity could only reflect some subsystem works in port, they are valid in measuring a specific field within port. Why port of Hamburg has achieved its position? First of all, they think in whole port of view in stead of profits.

Just as we mentioned in Chapter:1, part of the whole system is the best does not mean the whole system is the best.. In addition, that all parts of the whole systems are all best is also not equal to that the whole system is the best at that moment.

For improve port operation, we need to find main bottleneck of the whole port system. That is we should concentrate on one certain functioning subsystem within port on a specific time, which function will have the biggest effect on the port proceeding.

As resources are limited, if in a very competitive environment, a systematic vision is vital for a manager to survive.

## Conclusion

General system theory applies scientific principles and methods to the study of systems of all kinds. For port managers, system methods could provide a tool with a whole view of his business and also find the bottleneck of problem or main subsystem. The system analysis is a good decision-making support for different level managers.

From what we have discovered in port system analysis, it is believed that **system approach is not only able to solve technical problem in port, but also applied to port senior level management.**

**System thinking is required for port management and it provides a whole view for managers. In addition, system approach also can make the port manager find a way of avoiding failures.**

Failure has some reason to happen. If people think about the background of a failure they usually see the failure as the final event at the end of a short, linear chain of events that had a definite beginning followed by a short straight path to the inevitable outcome-disaster.

Once the chain of events was set in motion nothing could divert it from this path. They are not 'acts of God'. Rather they occur in a particular context, as a result, which has been accumulating for a period of time.



In system view failure is the production of undesirable outputs of the system. Systematic way of thinking could offer managers of port to avoid this shortcoming.

In the past, because of the less developed facilities and the quick pace of trade, congestion and time delay made big problems for port efficiency. As people utilised system methodology to solve these kind problems, such as net theory, simulation and queue theory. Now in many ports congestion is no longer so significant as before and most of the time delays are due to poor management instead of operation lack of facilities or investment.

Some mathematics methodology can solve the quantifiable problems of port operation but it could not solve non-quantifiable problems, such as human elements, which is the most difficult thing to control. However, these kind elements play a dominant role as development of port.

As port develop, and economy, more and more ports are emerged, and congestion may not be any question, in stead, ports begin to do marketing to attract cargo, they compete for more cargoes, which means now the main problem has changed. For example, from the system point of view, we should take environment and sustainable development issues into account.

So we can say that the system theory used nowadays is no longer the same concept as it used to be. So, the system approach becomes more qualitative rather than quantitative.

In system field, a reform from its previously methods to a new way of thinking will happen soon. This consequently will have influence on the system approaches, which used to solve port problems.

Finally, the in-tangible elements in port will become tangible in the end as long as the system theories develop to a certain extent.

In the end of this dissertation, the author would like to suggest the next step work, since we have already set up a general structure of port system and analysed a subsystem within it in more detail.

In the future, we could analyse more and more subsystems, after each subsystem has been analysed, we could get a port model and know function of each part of port and the interrelations. Finally, system integration could enable port operation to be more cost-effective and efficient by sharing resources and information through system optimising methods.

## Bibliography

ADEDEJI BODUNDE BADIRU (1995), *Industries Guide to ISO 9000*, Canada: John Wiley & Sons, Inc.

Alan E. Branch (1986). *Elements of Port Operation and Management*. London & New York: Cahpman and Hall.

Barry Richmond (1994). 'System Dynamics/systems Thinking: Let's just get on with it'. *International Systems Dynamics Conference*. <http://www.hps-inc.com/st/paper.html>

Basic Concepts of the Systems approach. (1998). <http://pespmc1.vub.ac.be/SYSAPPR.html>.

Bernard FRANCOU (1999). Port Performance Indicators. Lecture notes. World Maritime University, Malmö, Sweden.

B.Francou(1999), Port Impacts on the Economy, Handouts, Malmö: World Maritime University.

C.Jotin Khisty (1990). *Transportation Engineering: an Introduction*. New Jersey: PRENTICE HALL.

Deterministic chaos (1998). <http://pespmc1.vub.ac.be/CHAOS.html>.

Douglas M. L, James R. S and Lisa M. E. (1998). *Fundamentals of Logistics Management*. Singapore: McGraw-Hill.

E.M.L.Beale (1988). *Introduction to Optimisation*. USA: Wiley- Interscience Publication.

Ernest F.Haeussler, JR. Richard S. Paul (1990). *Introductory Mathematical Analysis*. USA: Prentice Hall International.

Ernst G. Frankel (1987). *Port Planning and Development*. USA: John Wiley & Sons, Inc.

'From Traditional Warehousing to European Logistics Centre' (1998). *Port of Hamburg*, Vol.4. United Kingdom: Compass Publications limited.

Gunther Ossimitz (1998). The Development of Systems Thinking Skills Using system Dynamics Modelling Tools. [http://www.uni-klu.ac.at/~gossimit/sdyn/gdm\\_eng.htm](http://www.uni-klu.ac.at/~gossimit/sdyn/gdm_eng.htm).

J.A.Green (1988). *Sets and Groups, a First Course in Algebra*. London and New York: Routledge & Kegan Paul.

Jean-Georges BAUDELAIRE (1986). *Port Administration and Management*. Tokyo: The international Association of Ports and harbours.

Jean M.Mancion(1998). Basic Elements of Port Operation systems. Lecture notes. World Maritime University, Malmö, Sweden.

Ludwig von Bertalanffy (1973). *General System Theory: Foundations,Development, Applications*. New York:George Braziller.

Malcolm Bull (1989) *Systems development using Structured techniques*. London: Chapman and Hall computing.

Marc H.Juhel (1999). 'Global Challenges for Ports and terminals in the new Era', *Ports and harbours*, Vol.44, No.2,pp 17-27.

Martin Gandoff (1989). *Systems analysis and Design*. Oxford: Heinemann Newnes.

Ma Shuo (1998). Logistics. Lecture notes. World Maritime University, Malmö, Sweden.

Ma Shuo (1998). Interviews. World Maritime University, Malmö, Sweden.

Ma Shuo (1999). Interviews. World Maritime University, Malmö, Sweden.

Ma Shuo (1999). Port Marketing. Lecture notes. World Maritime University, Malmö, Sweden.

P. Donner (1998). Accounting. Lecture Notes. World Maritime University, Malmö, Sweden.

P M Alderton (1999),An Analysis of Change concerning Ports, Handouts, Malmö: World Maritime University.

Port of Hamburg handbook 1997/98. United Kingdom: Compass Publications limited.

Ronald Gould (1988). *Graph Theory*. USA: The Benjamin/Cummings Publicating Company, Inc.

Transport'99 (1999)., *Port of Hamburg*, Ausgabe 2, pp 24-27. United Kingdom: Compass Publications limited.

System definitions (1998). <http://www.smeal.psu.edu/misweb/systems/sycodef.html>

Victor Bignell and Joyce Fortune(1984). *Understanding Systems Failures*. USA: Manchester University Press.

World Maritime University (1998) *Dissertation Guidelines*. Malmö: World Maritime University.

UNCTAD (1976) *Manual on Port Management: Modern Management Technique*. New York: United Nations Publication.

UNCTAD (1997). *Improvement Port Performance*. New York: United Nations Publication.

UNCTAD (1985) *Port Development: A handbook for planners in Developing Countries*. New York: United Nations Publication.