

2009

Effective implementation of emission control area towards cleaner shipping operations : focusing on sulphur oxides (SO_x) emission reduction

Fajar Nugraha
World Maritime University

Follow this and additional works at: http://commons.wmu.se/all_dissertations



Part of the [Environmental Studies Commons](#)

Recommended Citation

Nugraha, Fajar, "Effective implementation of emission control area towards cleaner shipping operations : focusing on sulphur oxides (SO_x) emission reduction" (2009). *World Maritime University Dissertations*. 186.
http://commons.wmu.se/all_dissertations/186

This Dissertation is brought to you courtesy of Maritime Commons. Open Access items may be downloaded for non-commercial, fair use academic purposes. No items may be hosted on another server or web site without express written permission from the World Maritime University. For more information, please contact library@wmu.se.

WORLD MARITIME UNIVERSITY

Malmö, Sweden

**EFFECTIVE IMPLEMENTATION OF
EMISSION CONTROL AREA
TOWARDS CLEANER SHIPPING OPERATIONS:**

Focusing on Sulphur Oxides (SO_x) Emission Reduction

By

FAJAR NUGRAHA

Republic of Indonesia

A dissertation submitted to the World Maritime University in partial
fulfilment of the requirements for the award of the degree of

MASTER OF SCIENCE

In

MARITIME AFFAIRS

(MARITIME SAFETY AND ENVIRONMENTAL ADMINISTRATION)

2009

Declaration

I certify that all the material in this dissertation that is not my own work has been identified, and that no material is included for which a degree has previously been conferred on me.

The contents of this dissertation reflect my own personal views, and are not necessarily endorsed by the University.

Signature: 

Date: August 24, 2009

Supervised by:

Jan-Åke Jönsson

World Maritime University

Assessor:

Olof Linden

World Maritime University

Co-Assessor:

Dragos Rauta

The International Association of Independent Tanker Owners (INTERTANKO)

Acknowledgement

Firstly, I would like to express my gratitude to the Almighty Allah for His mercy and guidance all through my life up to this moment. Completing this dissertation, a product of several months' work, I feel deeply indebted to many people who have greatly inspired and supported me during my master study at World Maritime University Malmö especially in writing this dissertation.

I owe my sincere gratitude to Biro Klasifikasi Indonesia (Indonesian Classification Society) and its President Director Muchtar Ali and Technical Director Haryanto for nominating me to this course. I am also particularly grateful to the Dr. Yohei Sasakawa for his generous financial support in the scheme of Sasakawa Fellowship which contributes greatly to my study and research for the dissertation.

I would like to give special thanks to Jan-Åke Jönsson for reading and making helpful comments on draft chapters. His invaluable guidance with academic perspective help me through the coarsely path of research. Without his supervision, I would not have completed this challenging dissertation. Furthermore, I would like to thank Niklas Berg, a researcher from Optical Remote Sensing Research Group, Chalmers University of Technology, Gothenburg and Gunnar Ericksson from Swedish Maritime Administration for providing me with the data and information regarding airborne emission surveillance project and emission trading respectively for this dissertation.

My further thanks also go to Inger Battista for her invaluable guidance, constructive suggestions to increase my capacities in the English language. My gratitude also goes to Cecilia Denne and Mia Hedin for supporting me in the collection of books and materials for the research work.

I also wish to express my sincere thanks and appreciation to my Swedish friend, Peter Hellberg for facilitating me to have contact persons in Swedish Maritime Administration. I would like to thank to Ondy for allowing me to access various scientific journals from his computer and Aditya for his most valuable skill in

computer which helped to perform the necessary layout of dissertation. Furthermore, thanks to all Indonesian friends: Jan, Poppy, Rona, Dewi, Nilam, Oryz, Arief, Didin and Yudi that make my life so colourful in Malmö. Moreover, my further thanks also go to my friends in MSEA study group: Kim, Park, Javier, Yasuhiro, Rino and Ping for international friendship and fruitful discussions during my study in MSEA.

My most sincere thanks go to my dear parents, Arief Supandi, Srie Maspupah and my parents-in-law, Kosasih and Uut Kutriyah. Their permanent love and confidence in me have encouraged me to go ahead in my study and career.

Finally, but definitely not the least, I would like to dedicate my dissertation to my wife Besta Niswatul Umami for the ever so many sacrifices and inconveniences she has taken and who has patiently supported me through the tough times while raising our sons (Ariq Qorihatunnasik and Muhammad Najwan Azhim Muntazhar) alone. I am sorry for not being able to accompany or witness every step of their growing up in the two years of my study. Your love and support at all times has seen me through good times and bad, more than I can put in words.

Abstract

Title of Dissertation : **Effective Implementation of Emission Control Area
Towards Cleaner Shipping Operations:
Focusing on Sulphur Oxides (SO_x) Emission Reduction**

Degree : **MSc**

The SECA regime was implemented in the Baltic Sea and the North Sea in 2006 and 2007 respectively to restrict the use of sulphur content in fuel to 1.50% or by means of exhaust gas cleaning systems or any other technological methods. Although regulation 14 of MARPOL Annex VI in the case of SECA has been fully enforced since 2006, the effectiveness of the SECA regime to reduce SO_x emissions is questionable because statistics show SO_x emissions remain increasing to the year 2030. Accordingly, the dissertation is attempting to investigate problems causing non effective implementation of SECA and to find technical and operational solutions.

The problem of low sulphur fuel availability can be addressed by boosting the use of exhaust gas cleaning systems and Liquefied Natural Gas (LNG). Furthermore, the complexity of the change over process can be minimized by retrofitting existing bunker tanks, adopting a guidance of the fuel change over process and selecting appropriate lubrication oil. Moreover, the dissertation reveals that the Automatic Identification System (AIS) is the vital instrument to improve accuracy in SO_x emission monitoring and SO_x emission inventory. In particular, SO_x emission monitoring through air and land surveillances is expected to minimize paper based inspection and time consuming fuel tests in laboratories. Finally, the solutions within the framework of the SECA loop system are the improvement processes which should be performed to achieve effective SECA implementation in decreasing SO_x emissions gradually

Keywords: Environment, SO_x, emissions, fuel, SECA, ECA, AIS, loop-system.

Table of Contents

Declaration	i
Acknowledgement	ii
Abstract	iv
Table of Contents	v
List of Tables	ix
List of Figure	x
List of Abbreviations	xi
1. INTRODUCTION	1
1.1. Background of study	1
1.2. Scope, objective of the study and research methodology	3
1.3. Organization of the dissertation	4
2. THE IMPACT OF AIR POLLUTION FROM SHIPPING OPERATION ON ENVIRONMENT AND HUMAN HEALTH	6
2.1. The recent trend of maritime transportation	6
2.2. Air emissions from shipping	7
2.2.1. Geographical distribution of ship traffic	7
2.2.2. Global shipping emission inventories	10
2.2.3. Comparison between ship emissions and other polluters	11
2.3. The effects of high sulphur content of fuel oil on ship operations	14
2.4. Ship emission impact in selected sea areas	15
2.4.1. The Baltic Sea	15
2.4.2. The North Sea and the English Channel	18
2.4.3. The Mediterranean Sea	19
2.4.4. The US and Canadian waters	21
2.4.5. The Straits of Malacca	23
2.5. Conclusion	25
3. EMISSION CONTROL AREA	27
3.1. The Background of Annex VI of MARPOL	27
3.2. Emission Control Area	28
3.2.1. The Background of Emission Control Area	28
3.2.2. Emission Control Area (ECA) Criteria	29
3.2.3. The Baltic and North Sea SECA	30

3.2.3.1. Relevant SO _x emission regulations	31
3.2.3.2. The impact of SECA on ship operations	31
3.2.3.3. The Benefit of the Baltic and the North Sea SECA	32
3.2.4. The forthcoming ECA: US and Canadian Waters	33
3.2.4.1. Relevant NO _x , SO _x and PM emission regulations	35
3.2.4.2. The impact of ECA on the ship operations	35
3.2.4.3. The Benefit of US and Canadian Waters ECA	37
3.3. The Methods of SO _x Emission Reduction	38
3.3.1. Low Sulphur Fuel Oil (LSFO)	39
3.3.1.1. Fuel Oil Availability	41
3.3.1.2. Fuel Oil Quality	41
3.3.1.3. The annual costs of LSFO and tank modification costs	42
3.3.1.4. The benefit of LSFO	43
3.3.2. Exhaust gas cleaning systems	44
3.3.2.1. Sea water scrubber	45
3.3.2.2. Fresh water scrubber	46
3.3.2.3. The requirement of exhaust gas SO _x cleaning system onboard	47
3.3.3. Other technological methods	48
3.4. Supporting policy to encourage SO _x emissions reduction	49
3.4.1. Fairway dues	49
3.4.2. Port dues	50
3.4.3. Emission Trading Scheme	51
3.5. Conclusion	53
4. THE EFFECTIVENESS OF SECA IMPLEMENTATION	55
4.1. Ishikawa diagram of SECA problems	56
4.2. Marine fuel availability	57
4.2.1. The availability of 1.00% sulphur fuel oil	57
4.2.2. The availability of 0.10% sulphur fuel oil	58
4.2.3. The complexity of incremental refining capacity	59
4.2.4. What can be done	60
4.2.4.1. Scrubbers: the most feasible alternative method	61
4.2.4.2. The Problems and Opportunities of Scrubbers	62

4.2.4.3. Liquefied Natural Gas (LNG): fuel of the future	63
4.3. Machinery: Fuel system arrangements to comply with SECA requirement	65
4.3.1. Existing ships with single tanks for two grades of fuel oil	65
4.3.2. Existing ships with segregated tanks for two grades of fuel oil	67
4.4. Lubrication system	70
4.5. SO _x emission measurement	71
4.5.1. Airborne Surveillance	72
4.5.1.1. Differential Optical Absorption Spectroscopy (DOAS) measurement	73
4.5.1.2. Sniffer measurement	75
4.5.2. Land surveillance	77
4.5.3. Automatic Identification Systems (AIS) data use in SO _x emission estimation	79
4.5.3.1. The uncertainty of fuel oil estimation	79
4.5.3.2. Ship movement based upon AIS	80
4.6. The future scenario of SO _x emission monitoring	81
4.7. The SECA loop system for effective implementation	84
5. CONCLUSIONS AND RECOMMENDATIONS	86
5.1. Conclusions	86
5.1.1. The SECA planning	87
5.1.2. The SECA execution	88
5.1.3. The SECA monitoring	89
5.1.4. The SECA evaluation	90
5.2. Recommendations	90
References	92
APPENDICES	103
Appendix A. Impact of NO _x , SO _x and PM emissions on environment and human health	103
A.1. Eutrophication	103
A.2. Ground Level Ozone	103
A.3. Acidification	103
A.4. Human health	105

Appendix B. Special areas under MARPOL	105
Appendix C. European Union Regulations – Application in EU Member States	108
Appendix D. CARB Directive, California Air Resources Board – Application in California, US	109
Appendix E. Transport and Environment Canada – Application in CANADA	109
Appendix F. NOx emission requirement: Tier I, Tier II and Tier III	110
Appendix G. ECA documentations related to low sulphur fuel oil method	112

List of Tables

Table 2-1. Selected global emission inventories from 1996 to 2012	10
Table 2-2. Comparison of emissions from heavy truck and various types of cargo vessels	13
Table 3-1. The total cost of compliant SO _x and NO _x emission regulation	36
Table 3-2. Annual cost of fuel switching for different size of ships	42
Table 3-3. SO ₂ and PM emissions are caused by fuel switching	44
Table 3-4. The differentiated fairway dues in Swedish waters	50
Table 4-1. The estimation of HFO and distillate fuel in 2007 and 2020	60
Table 4-2. Costs effectiveness of SO ₂ reduction measures comparison between seawater scrubbers and fuel switching	61

List of Figure

Figure 2-1.	The ship traffic density in June 2009 based on AMVER	8
Figure 2-2.	Approximation of ship distribution based on ICOADS	9
Figure 2-3.	Comparison air emissions among transport modes in 2000	12
Figure 2-4.	The Map of Mediterranean Sea	20
Figure 2-5.	The Straits of Malacca Map	24
Figure 3-1.	The SECA delineation of the Baltic and North the Sea	31
Figure 3-2.	The estimation of SO _x emissions within the Baltic and the North Sea SECA	33
Figure 3-3.	The ECA delineation of EEZ US and Canada	34
Figure 3-4.	ECA and global sulphur cap reduction progress from 2006 to 2020	39
Figure 3-5.	IMO sulphur monitoring program from 2003 to 2008	40
Figure 3-6.	Principle diagram of seawater scrubbing (SWS) process	45
Figure 3-7.	Principle diagram of freshwater scrubbing (FWS) process	47
Figure 3-8.	SO _x emission trading mechanism	52
Figure 4-1.	Emissions of SO ₂ from 1990 to 2010	55
Figure 4-2.	The Ishikawa diagram of SECA problems	56
Figure 4-3.	The price comparison among MGO, HFO and LNG	63
Figure 4-4.	Fuel system with single settling and service tanks	66
Figure 4-5.	Fuel sulphur content vs time when alternating between 2.90 % and 1.40 % sulphur.	66
Figure 4-6.	Example of tank modification	68
Figure 4-7.	Fuel system with double settling and service tanks	69
Figure 4-8.	Dilution time to reach 1.50% S in percent of the fuel oil hours contained in the blending volume	70
Figure 4-9.	The DOAS instruments (left) and optical measurement of an oil tanker (right)	74
Figure 4-10.	The scientist of Chalmers installing the sonde in the airplane	76
Figure 4-11.	Mixing ratios above ambient conditions for SO ₂ and CO ₂ to determine sulphur content in fuel oil	76
Figure 4-12.	The integrated system of airborne surveillance, land surveillance, exhaust gas monitoring and SO _x emission inventory	83
Figure 4-13.	The SECA loop system for effective implementation	84

List of Abbreviations

AIS	Automatic Identification System
AMVER	Automated Mutual Assisted Vessel Rescue System
BDI	Baltic Exchange Dry Index
BDN	Bunker Delivery Note
BDTI	Baltic Exchange Dirty Tanker Index
BN	Base Number
CO	Carbon Monoxide
CO ₂	Carbon Dioxide
DOAS	Differential Optical Absorption Spectroscopy
DWI	Direct Water Injection
DWT	Dead Weight Tons
ECA	Emission Control Area
EGCS	Exhaust Gas SO _x Cleaning Systems
EIA	Energy Information Administration
EPA	Environmental Protection Agency
ETM	EGCS Technical Manual
GHG	Green House Gas
gr/kW.h	gram/kilowatt.hour
GRT	Gross Register Tons
GT	Gross Tonnage
HAM	Humid Air Motor
HELCOM	Helsinki Commission
HFO	Heavy Fuel Oil
HSFO	High Sulphur Fuel Oil
HIX	Hamburg Index
ICOADS	International Comprehensive Ocean–Atmosphere Data Set
IEA	International Energy Agency
IFO	Intermediate Fuel Oil
IMO	International Maritime Organization
IPIECA	International Petroleum Industry Environmental Conservation Association

LNG	Liquefied Natural Gas
LSFO	Low Sulphur Fuel Oil
MARPOL	Marine Pollution
MCA	Maritime Coastguard Agency
MDO	Marine Diesel Oil
MGO	Marine Gas Oil
mg Sm ⁻² yr ⁻¹	milligram Sulphur/square meter year
MEPC	Marine and Environmental Protection Committee
nm	Nautical Miles
NO	Nitrogen Monoxide
NO ₂	Nitrogen Dioxide
NO _x	Nitrogen Oxide
PAH	Polycyclic Aromatic Hydrocarbons
PM _{2.5}	Particulate Matter with particles smaller than 2.5 µm
ppb	Part per billions
ppm	Part per millions
PSC	Port State Control
REMPEC	Regional Marine Pollution Emergency Response Centre for the Mediterranean Sea
Rpm	Revolution per minute
SCC	SECA Compliance Certificate
SCR	Selective Catalytic Reduction
SECA	SO _x Emission Control Area
SO ₂	Sulphur Dioxide
SO ₃	Sulphur Trioxide
SO ₄	Sulphur Tetraoxide
SO _x	Sulphur Oxide
Tg	Tetra gram
EU	European Union
UNCTAD	United Nations Conference on Trade and Development
VIMSAS	Voluntarily IMO Member States Audit Scheme
VOC	Volatile Organic Compound
WORLD	World Oil Refining Logistic and Demand

CHAPTER 1

INTRODUCTION

1.1. Background of study

Ocean going vessels are the most efficient transport mode, but they generate a substantial amount of waste during their operation. Over the last three decades, the international community is concerned with the adverse effects of maritime activities on the environment since MARPOL was adopted in 1973. The primary concern of IMO was on hazardous discharge prevention from vessels to sea through MARPOL Annex I to V within the first two decades. It is possibly because the effects of hazardous disposals on the marine environment including contaminated sea and marine ecosystem destruction are more noticeable than air pollution from shipping. Furthermore, perhaps the impact of ship air emissions on the environment and human health had not been realized at that time.

In the last three decades, air pollution issues have been discussed intensively considering that shipping activities worldwide contribute to the global anthropogenic emissions of air pollutants. IMO took initiative to reduce ship emissions with the elaboration of regulations in Annex VI of MARPOL 73/78, which was adopted by a further Protocol in 1997 and ratified by a sufficient number of member states to enter into force on 19 May 2005. The document regulates the various aspects of air pollution control, means of control, survey and certification of every ship of 400 gross tonnage and above, equipped with engine with a power output of more than 130 kW especially in compliance with Regulation 13 Nitrogen Oxides (NO_x), fixed and floating drilling rigs and other platforms.

In particular, coastal zones are the worst affected areas of emissions from shipping. An estimation is that around 70 percent of all ship emissions emanate from a zone within 400 km (248 miles) of the coast line (Corbett, Fischbeck, & Pandis, 1999). Ship emissions consist of Nitrogen Oxides (NO_x), Sulphur Oxides (SO_x), Volatile Organic Compound (VOC), Particulate Matter (PM) and Carbon Dioxides (CO₂),

which all have a connection with environmental degradation and human health damage. Unlike oil spill pollution, exhaust gasses will dilute immediately; therefore, air pollution contingency plans might not exist and the consequences of air pollution could not be combated by deploying response teams. Accordingly, preventive action through the stricter control of ship exhaust fumes is required to protect the inhabitants of coastal zones and their ecosystems from further devastation.

In the beginning of the legislation process, IMO took measures to mitigate only SO_x emissions from ships within coastal areas through SO_x Emission Control Area (SECA), which restricts sulphur content in fuel oil at a certain level. The Baltic Sea is the first designated SECA and was followed by the North Sea including the English Channel under regulation 14 of Annex VI. It entered into force on 19 May 2006 for the Baltic Sea and 22 November 2007 for the North Sea and the English Channel. The sulphur content of any fuel oil consumed onboard ships navigating within SECA must not exceed 1.50%¹, while the global sulphur cap must not exceed 4.50%.

In October 2008, Annex VI was amended by the MEPC at the 58th session, including a gradual decrease in the amount of SO_x emissions, which will enter into force on July 1, 2010 under tacit acceptance procedures. A progressive reduction in sulphur content of fuel oil to 1.00% will be effective from 1 March 2010 and to 0.10% beginning on 1 January 2015 within ECA²; meanwhile the global sulphur cap will be restricted to 3.50% from 1 January 2012, then gradually to 0.50% from 1 January 2020 subject to a feasibility study by 2018 (International Maritime Organization [IMO], 2008d). The ambitious plan of IMO is expected to minimize SO_x emissions from ships significantly as per the emissions of land based source.

¹ Previously, the standard of fuel content in fuel oil was decided in one decimal digit namely 1.5% (ECA) and 4.5% (global sulphur cap). Nowadays, the IMO unified interpretation requires two decimal digits namely 1.50% and 4.50%

² ECA : Emission Control Area is a new terminology to replace SECA since ECA accommodates SO_x, NO_x and PM emissions which will enter into force in 2010. In this dissertation, SECA terminology will be used to discuss SO_x emission reduction in the Baltic Sea, the North Sea and the English Channel. Furthermore, the discussions in Chapter 4 focus on sulphur oxides (SO_x) emissions. Consequently, SECA is suitable terminology to be used.

Unfortunately, IMO's endeavour to lessen SO_x exhaust impacts may face tough challenges because of the availability of low sulphur fuel oil (LSFO) and the reliability of exhaust gas cleaning system technology. Firstly, some uncertainty remains regarding the supply of LSFO from oil refinery industries to the existing SECA and the potential ECA in the decided timeframe. They will find difficulties to satisfy an increased demand of LSFO in amounts up to 10 million tonnes by 2010 to supply the SECA and further, if the US and Canadian waters will be designated as ECA (Meech, 2005, p.16). IMO can not enforce oil refineries to meet such demand, because they might consider commercial aspects before executing the IMO plan.

Secondly, exhaust gas cleaning system technology, such as water scrubbers utilize sea water to absorb and to neutralize SO_x. Although SO₂ emissions could be lowered by 66% with sea water scrubbers (Andreasen & Mayer, 2007, p. 3274), the negative effects of waste discharge from the equipment in the environment has not been resolved enough. Thus it has been running under trial to meet IMO requirements.

The SECA problems are not only the availability of low sulphur fuel oil (LSFO) and the reliability of exhaust gas cleaning system technology, but also other technical and operational difficulties and their consequences arise. These weaknesses will possibly disrupt the arrangements to lower SO_x emissions in 2015 which might lead to the worst impacts on the environment and human health within coastal zones.

1.2. Scope, objective of the study and research methodology

The scope of this dissertation is based on the implementation of SECA in the Baltic Sea, the North Sea and the English Channel, although several potential ECA will be discussed in Chapter 2. In essence, this dissertation is attempting to investigate problems which cause non effective implementation of SECA and to deal with them. The final result of the dissertation is technical and operational solutions in the framework of SECA loop system, which should be performed to achieve effective ECA implementation in decreasing SO_x emissions gradually. Furthermore, the discussion in this dissertation might be applicable to similar problems when potential

ECA and the global sulphur cap of 0.50% sulphur content in fuel will be introduced in 2020.

Accordingly, the objectives of this dissertation are:

- Illustrate the latest development of shipping operations and their impact on the environment and human health.
- Explain the ECA scheme in conjunction with various methods to minimize SO_x emissions and supporting economic incentive policies.
- Discuss problems related to the effectiveness of SECA implementation and investigate possible technical and operational solutions to overcome these problems.

The author will conduct research mainly with the qualitative method through critical review, investigate, discuss literature and express the author's opinions in the dissertation. Furthermore, Ishikawa diagram is employed as a qualitative tool to identify problems related to the non effective implementation of SECA regime. Moreover, correspondence with experts on air pollution issues will be carried out to improve the quality of the research. A considerable number of books, articles, reports and case studies have been published by researchers and institutions which will be used to support this dissertation.

1.3. Organization of the dissertation

The research work of the dissertation will be divided into five chapters, as follows:

- Chapter one is introductory chapter to the dissertation.
- Chapter two will take an overview of the latest development of shipping activities in relation to ship traffic density worldwide and air emission concentration in coastal areas. It should be noted that the use of high sulphur fuel onboard is the main cause why air emissions from ships devastate the environment and human health. Furthermore, air emission inventories from ships and their comparison with other emission sources from land and air transport is important information to show the contribution of airborne emissions from ships to the air quality. The main point of Chapter two is to identify SO_x, NO_x and PM emission impacts on

the environment and human health in areas within the Baltic Sea, the North Sea and the English Channel, the US and Canadian waters, the Mediterranean Sea, and the Strait of Malacca.

- Chapter three provides background information about ECA and the criteria to designate areas for controlling emissions. The impacts and benefits of the SECA regime in the Baltic Sea, the North Sea and the English Channel will be explained including the forthcoming ECA in the US and Canadian waters. This chapter will also discuss measures taken by IMO to lower SO_x emissions and the relevant regulations in Annex VI MARPOL /3/78, which deal with this issue. It is important to observe several economic policies including fairways, port dues incentives and emission trading, which encourage the efforts to lower SO_x emissions.
- Chapter four will analyze and discuss problems related to the effective implementation of the SECA scheme and provide technical and operational solutions which should be conducted to overcome SECA problems.
- Chapter five presents the overall conclusions of the dissertation on how the scheme could be improved and implemented effectively and contains also some recommendations.

CHAPTER 2

THE IMPACT OF AIR POLLUTION FROM SHIPPING OPERATION ON ENVIRONMENT AND HUMAN HEALTH

2.1. The recent trend of maritime transportation

Obviously, the increase in global ship emission inventories³ relates to maritime transport services which are driven by international trading. Merchant vessels play a significant role in transporting cargo worldwide with over 80% of world trade by volume. In 2007, the total goods loaded exceed 8 billion tons⁴, of which dry cargo was in predominance of goods loaded (United Nations Conference on Trade and Development [UNCTAD], 2008a, p.5). The demand of international seaborne trade influences world fleet number significantly to the supply carrying capacity. The world fleet of propelled sea-going merchant ships of more than 100 GT comprises 97,504 ships of 774.9 million GT with an average age of 22 years (IMO, 2008e, p.8) and comprises general cargo ships, bulk carriers, container ships, oil tankers and passenger ships. In general, the number of dedicated dry and liquid cargo ships transporting grain, coal, iron ore, bauxite/alumina, phosphate, oil and other cargoes have increased gradually over three decades. A review of loaded cargo statistic reveals that the characteristic of maritime transport is high volume carriage with low value goods (e.g. grain and phosphate), despite the amount of high value of manufactured products carried by containers has increased.

The international seaborne freight transport was 32,932 billion ton-miles in 2007, which compares favourably with that at 31,447 billion ton-miles in 2006, which is based on Fearnley's Review (as cited in UNCTAD, 2008a, p.10). The economic crisis has a tremendous implication for such figures considering the demand for maritime transport services and the supply of ship capacity, which can be captured from the transport freight rate. The transport freight rate of different commodities is represented by Baltic Exchange Dry Index (BDI) for dry bulk, the Baltic Exchange

³ *The amount of emissions is estimated in the certain area in the period of time*

⁴ *Ton is a weight unit equal to 2240 pounds (Britain) or 2000 pounds (US)*

Dirty Tanker Index (BDTI) for crude oil and the Hamburg Index (HIX) for container. The BDI dropped dramatically more than 11-fold from 11,793 in May 2008 to 891 in November 2008 (UNCTAD, 2008b) followed by BDTI (from around 2100 in May 2008 to below 600 in February 2009) (UNCTAD, 2009, p.14) and HIX as Dynamar (2009) writes “HIX decreased by 24% and 75% in February 2008 and February 2009 respectively” (UNCTAD, 2009, p.11).

A global downturn in the aforementioned indexes is largely due to the sharp decline in the demand of transport services because the financial crisis resulted in the lack of international trade. The consequence of lower demand for maritime transport is that a small percentage of merchant ships have been idle and laid up. For example, Lloyd’s List (2009) reveals “about 17.3 million dead weight ton of bulk carrier fleet or 9% of the global fleet, is now idle” (as cited in UNCTAD, 2009, p.10) and Containerization International (2009) reports “11% of the world container fleet is laid up” (as cited in UNCTAD, 2009, p.12). The recovery of shipping business from the miserable situation may take a few months up to several years. In particular, the BDI in February 2009 climbed up to 2000 from 600 (UNCTAD, 2009, p.11). However that does not necessarily mean a positive indicator of recovery because other indexes remain in under performance. Although the economic crisis is still going on, high volume cargo carriage with lower shipping costs has created economies of scale to ensure merchant vessels remain the pre-eminent mode of transport. Thereby, the development of maritime transports is expected to increase emission inventories, although the economic crisis is still going on.

2.2. Air emissions from shipping

2.2.1. Geographical distribution of ship traffic

Ships are “mobile bridges” which link loading ports with unloading ports worldwide. Loading ports and unloading ports are connected by major maritime trade routes between Europe and America, Asia and America, and Europe and Asia. Most loading ports are located in the Asian region, for example Singapore, and 8 China ports belong to the big twenty container terminals in terms of their throughput. In particular, shipping traffic density in the above stated routes is concentrated in areas

between 10° latitude north and 60° latitude north from the equator (figure 2.1). Thus, it was estimated that 85% of the ship traffic occurs in the northern hemisphere (Friedrich, Heinen, Kamakaté & Kodjak, 2007, p.24). In many ways, this is understandable, since large continents and most trade areas are located on the northern hemisphere. For example, the busiest trade route in the northern hemisphere is the trans Atlantic Ocean linking North America and European countries followed by shipping routes along the China coast.

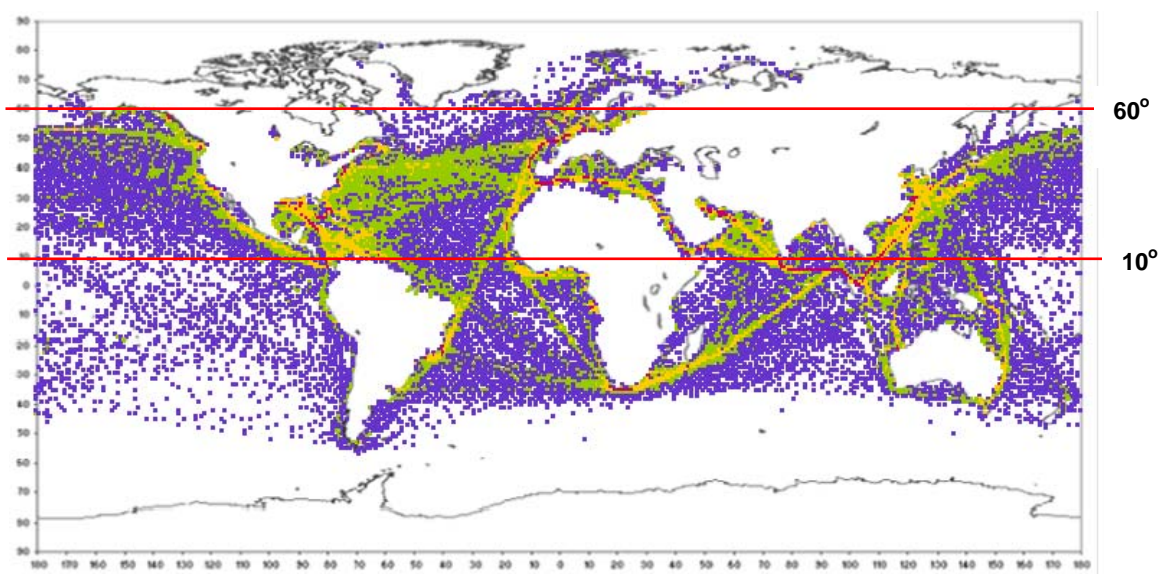

Figure 2-1. The ship traffic density in June 2009 based on AMVER

Source: AMVER. (2009). *AMVER density plot display*. Retrieved June 10, 2009 from the World Wide Web: <http://www.amver.com/density.asp>

Although the main shipping lanes are trans-ocean routes, the high ship traffic density occurs in coastal areas. As can be seen in Figure 2.1, according to Automated Mutual Assisted Vessel Rescue System (AMVER⁵), the trans-ocean route density is approximately only 5-14 vessels per month both Trans Atlantic and Trans Pacific routes (AMVER, 2009). Compared with several routes, such as east and west coast America, the North Sea and the Baltic Sea, the Mediterranean Sea,

⁵ It is developed by US Coast Guard and used to track vessel in the case of search and rescue operation

the Straits of Malacca and along the China coast show ship traffic from 15 to over 50 vessels per month. This ship traffic pattern is relatively the same as in previous months.

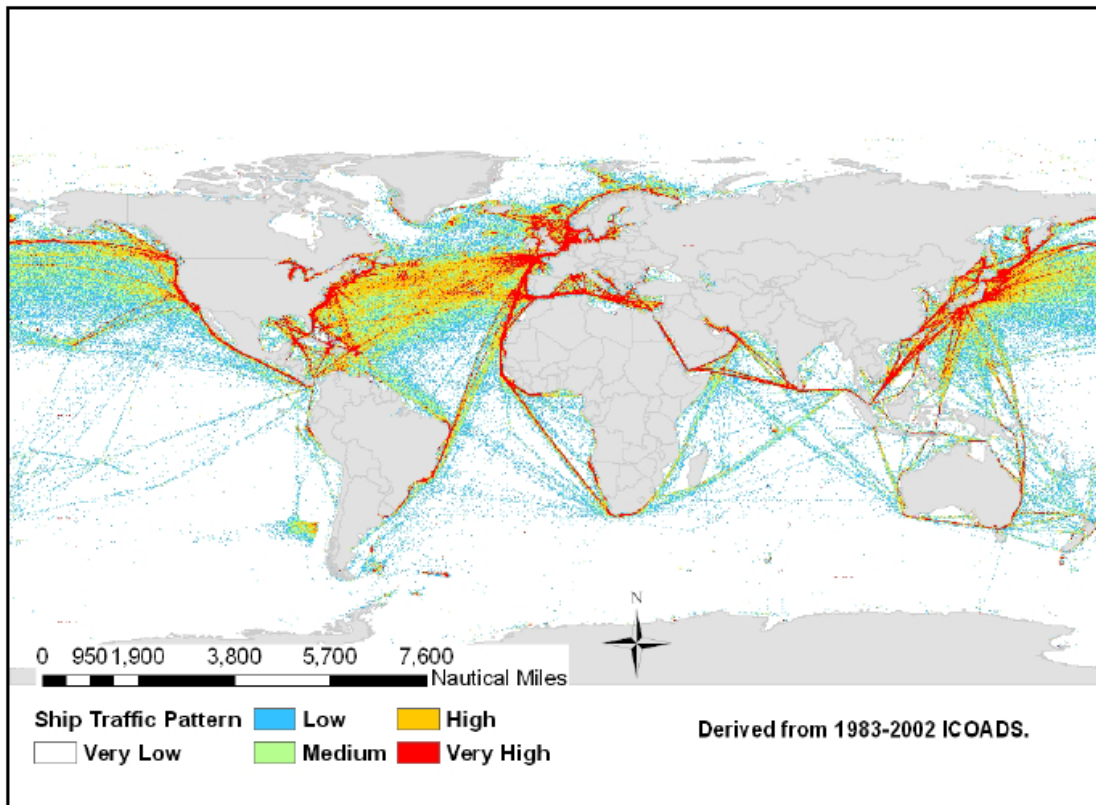

Figure 2-2. Approximation of ship distribution based on ICOADS

Source: International Maritime Organization. (2009c, April 9). Second IMO GHG Study 2009 Update of the 2000 IMO GHG Study Final report covering Phase 1 and Phase 2 Note by the Secretariat. (MEPC 59/INF.10). London: Author.

Global ship movements from International Comprehensive Ocean–Atmosphere Data Set (ICOADS⁶) and AMVER database reveal that the heaviest ship concentration is in the coastal area. From ICOADS database, a total of 1.9 million ships daily indicate that 70% of ship traffic occurs within 200 nm from shore, 44% of ships concentrate within 50 nm from shore and 36% of ships operate within 25 nm from shore (IMO, 2009c, p. 21). The huge amount of traffic density in these regions contributes to air quality problems on land. It is influenced by wind direction and wind velocity, although ships are releasing emissions from sea. The fact that

⁶ It is developed by US National Oceanic and Atmosphere Administration

shipping emissions spread hundreds of kilometres inland proves that maritime transport is a serious threat to the environment and human health in urban areas.

2.2.2. Global shipping emission inventories

Ship engines generate three main polluting substances: carbon dioxide (CO₂), nitrogen oxides (NO_x) and sulphur oxides (SO_x). In fact, there are plentiful fumes discharged from ships such as nitrogen monoxides (NO) and nitrogen dioxides (NO₂) which are labelled as NO_x. SO_x emissions is predominantly SO₂, SO₃ (around 2-3%) and SO₄ (Alexandersson, 1991, p.40). Particulate matter (PM) is created by atmospheric reaction of NO_x and SO_x.

Emission studies consistently link shipping traffic density as a basis to estimate global shipping emission inventories, which have already been conducted by several scholars and institution (Endresen, Sørgeård, Sundet, Dalsøren, Isaksen, Berglen & Gravir, 2003; Eyring, Köhler, van Aardenne & Lauer, 2005; Corbet, Winebrake, Green, Kasibhatla, Eyring & Lauer, 2007; & IMO, 2009c). Selected emission inventories between 1996 and 2012 are presented in Table 2.1.

Table 2-1. Selected global emission inventories from 1996 to 2012

SOURCES	PUBLICATION YEAR	FUEL CONSUMPTION	NO _x	SO _x	PM _{2.5}	CO ₂	INVENTORY YEARS
		(10 ⁶ METRIC TONNES)					
Corbet, et al	2007	299	24.5	13.7	1.06	N/A	2012
IMO	2009c	333	25	15	1.8	1054	2007
Eyring et al	2005	280	21.4	12	1.7	813	2001
Endresen et al	2003	158	12	6.8	0.9	501	1996

(Source: as stated on table)

CO₂ is formed in comparatively large amounts in all types of emissions in combustion processes, and amounted to 1054 million tonnes⁷ in 2007. Over 16 years (from 1996 to 2012), the growth of NO_x and SO_x emissions are twice in number except ⁸PM_{2.5}. However, IMO estimated NO_x, SO_x and PM_{2.5} emissions in 2007 slightly larger than Corbet's prediction in 2012. The discrepancy of NO_x, SO_x and PM_{2.5} inventories between 2007 and 2012 is caused by uncertainty in fuel consumption prediction. IMO predicted that fuel consumption in 2007 accounted for 333 million tonnes higher than fuel consumption in 2012 according to Corbet et al (299 million tonnes). Thus, the fuel consumption has significant contribution to ship emission inventories.

There are at least three reasons to justify the upward trend in the amount of inventories. Firstly, MARPOL annex VI entered into force 2005 and has been implemented only for 4 years; therefore, it is impossible in a short period to reduce ambient pollution concentration significantly. Perhaps it requires more than a decade to gain satisfactory results. Secondly, MARPOL Annex VI provisions are less stringent in control on emissions magnitude which compromise with several factors such as fuel supply, engine age and even economic and political pressures. For example, although the average global sulphur accounts for 2.7% in 2005 (IMO, 2006a), IMO decided the global sulphur cap less than 4.50%; neither 4.00% nor 3.00%. It might involve substantial considerations before reaching agreement on this figure. Thirdly, several green house gas (GHG) emissions have not been regulated yet, such as CO₂ which has a larger amount of inventories than other ship emissions. Although major progress was made, including several IMO GHG study projects, GHG regulation might not be adopted in upcoming months.

2.2.3. Comparison between ship emissions and other polluters

IMO (2008e, p.29) urges that air pollution from ships contributes relatively small portions of the total volume of atmospheric emissions compared to road traffic and public utilities. It is acceptable since CO₂, which is the largest pollutant of ship

⁷ Tonne is a metric unit of weight that is equal to 1000 kilograms

⁸ Particulate Matter which have particles smaller than 2.5 µm

emissions, constituted only 3.3% of the global CO₂ emissions during 2007 (IMO, 2009c, p.7).

Nevertheless, shipping could be the largest polluters in comparison with road transport and aviation in the forthcoming years. This argument is supported by Eyring and Corbett (2007) who revealed that SO₂ from ships was the highest emissions of different transport modes corresponding to 12 Tg/year⁹ while the rest emissions occupied the second largest by the year 2000 (Figure 2.3). It is possible because Annex VI was effectively enforced in 2005, so shipping emissions were not yet regulated in 2000.

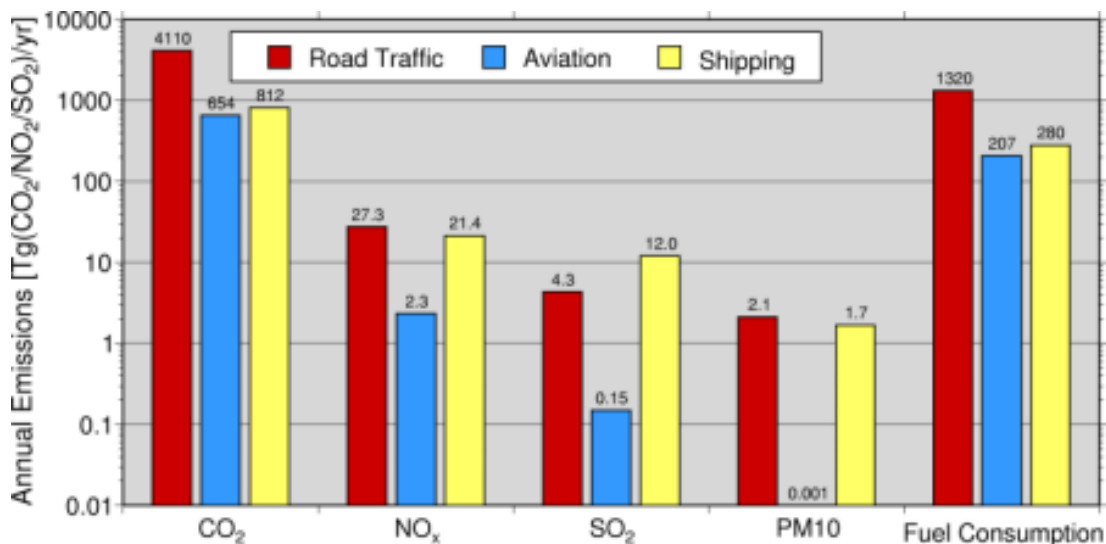

Figure 2-3. Comparison air emissions among transport modes in 2000

Source: Eyring, V., & Corbett, J.J. (2007). *Comparing Fuel Consumption, CO₂ and Other Emissions from International Shipping and Aircraft*. Retrieved June, 12 2009 from the World Wide Web: http://www.pa.op.dlr.de/SeaKLIM/Fuel_Emissions_International_Shipping.html

The air emission regulation of ships is less stringent than the air emission regulation of other transport modes especially road transport in Europe. With reference to table 2.2, comparison between heavy truck emissions and ship emissions is presented. For example, air emissions from heavy trucks have been controlled since 1990 and

⁹ Tg : Tetra gram. 1 Tg = 10¹² gram

the regulation related to trucks emissions is amended to more stringent standards almost every three years. In contrast, Annex VI was amended in 2008 almost eleven years after the Protocol of 1997 MARPOL Annex VI was adopted. Furthermore, Euro 3 standard regulated NO_x and PM emissions were limited to 5 gr/kW.h and at least 0.10 gr/kW.h respectively in 2000. On the contrary, Annex VI restricts NO_x emissions to 17 gr/kW.h released from engines running at less than 130 rpm. Moreover, there is no emissions reduction standard of PM in the Annex VI.

Table 2-2. Comparison of emissions from heavy truck and various types of cargo vessels

	CO ₂	PM	SO ₂	NO _x	VOCs
Heavy truck with trailer:					
Before 1990	50	0.058	0.0093	1.00	0.120
Euro 0 (1990)	50	0.019	0.0093	0.85	0.040
Euro 1 (1993)	50	0.010	0.0093	0.52	0.035
Euro 2 (1996)	50	0.007	0.0093	0.44	0.025
Euro 3 (2000)	50	0.005	0.0093	0.31	0.025
Cargo vessel:					
large (>8000 dwt)	15	0.02	0.26	0.43	0.017
medium size (2000-8000 dwt)	21	0.02	0.36	0.54	0.015
small (<2000 dwt)	30	0.02	0.51	0.72	0.016
RoRo (2-30 dwt)	24	0.03	0.42	0.66	0.029

Source: The European Environmental Bureau (The EEB), The European Federation for Transport and Environment (T&E), Seas At Risk (SAR), The Swedish NGO Secretariat on Acid Rain. (2004). *Air pollution from ships*. Retrieved June 10, 2009 from the World Wide Web: [http://www.eeb.org/activities/air/ship-briefing-nov04-\(1\).pdf](http://www.eeb.org/activities/air/ship-briefing-nov04-(1).pdf)

Consequently, air emissions from heavy trucks were significantly lower than from large ships. PM emissions from trucks (0.005 gr/ton kilometre) were a quarter of PM emissions released from ships (0.02 gr/ton kilometre) and SO₂ emissions from ships were almost 28 times higher than SO₂ from trucks. In this case, SO₂ emissions from trucks is lower than from ships because the sulphur content of diesel oil is around 300-350 ppm, but ships consume fuel with 26,000 ppm sulphur content. Accordingly,

it requires more stringent regulations to minimize air emissions from ships to catch up with the progress of road traffic emission standards.

2.3. The effects of high sulphur content of fuel oil on ship operations

The greatest environmental problem of maritime transport is Heavy Fuel Oil (HFO) with high sulphur content and used by most diesel engines. Merchant vessels largely consume fuel to generate main engines and auxiliary engines for ship propulsion and electricity onboard respectively. The heavy fuel oil consists of unwanted properties like incombustible transition metals, polycyclic aromatic hydrocarbons and sulphur which are residual oil from petroleum refining process to produce Marine Diesel Oil (MDO), Marine Gas Oil (MGO) and other distillate oil.

The unwanted properties make HFO price cheaper than distillate fuel oil. Intermediate Fuel Oil (IFO) 380 is the most commonly used for ocean going vessels. In Rotterdam, the price of IFO 380 is around US\$ 358/tonne, while MDO and MGO are US\$ 457/tonne and US\$ 497/tonne respectively in July 10, 2009, (Bunker word, 2009). The cheaper price of HFO is an advantage for ship operators to lower fuel costs considering incremental fuel costs if the engine consumes distilled products. It is the main reason why HFO is used by most ocean going ships. In fact, fuel costs is a dominant proportion of voyage costs accounting for 47 %, while voyage costs contribute to roughly 40% of the total operational costs (Stopford, 2009, pp. 232-233). Consequently, the fuel costs is the most important factor in the voyage costs which should be maintained as low as possible, otherwise it will bring negative effects on the total operational costs.

Nevertheless, HFO entails several drawbacks in shipping operations. For instance it must be heated to approximately 140°C because of viscous substances before it is ready to be burnt. Ships should have adequate sludge tanks to accommodate the sludge of HFO which can not be used during combustion but must be removed onboard. It will either be burnt into an incinerator or transferred to reception facilities. Above all, ship exhaust fumes are released from the combustion process using HFO in diesel engines which is vastly more harmful to human health and the environment.

2.4. Ship emission impact in selected sea areas

NO_x, SO_x and PM emissions cause eutrophication, ground level ozone, acidification and human health damage also in other parts of world than those selected in this Chapter, which can be read in Appendix A. In this Chapter, the impact of those emissions on the environment and human health in the selected sea areas will be discussed considering those emissions are restricted within ECA.

2.4.1. The Baltic Sea

The Baltic Sea is located in Northern Europe which consists of the Gulf of Bothnia in the north, the Gulf of Finland in the east, the Gulf of Gdansk and the Gulf of Riga in the south and the southeast respectively. The Baltic Sea is the largest brackish water basin in the world with an area of approximately 415 thousand square kilometres (Helsinki Commission [HELCOM], 2009). It is surrounded by 9 countries: Denmark, Sweden, Finland, Russia, Estonia, Latvia, Lithuania Poland, and Germany. The combination of sea water from the Baltic Sea and fresh water from rivers and rainfall contributes to the brackish water of the Baltic Sea. Quite few animal and plant species live in the low salinity of the Baltic Sea environment, which is similar to a lake or an estuary. Thus, a special characteristic of geography, oceanography and marine ecosystems makes the Baltic Sea vulnerable to pollution induced by human activities. Due to its vulnerability, the Baltic Sea is declared as special area¹⁰ under Annex I, Annex V and Annex VI of MARPOL 73/78. The list of special areas under MARPOL is presented in Appendix B. Furthermore, the Baltic Sea has been designated as a Particularly Sensitive Sea Area (PSSA¹¹) in 2005.

The Baltic Sea is a semi enclosed sea linked to the North Sea through the narrow and shallow straits of the Little Belt (0.8 km), Great Belt (16 km), and the Öresund (4 km) between Sweden and Denmark (HELCOM, 2007, p. 10) which is only 7-8 m in

¹⁰ *Special area is sea area where because of recognized technical reasons in relation to its oceanographical and ecological condition and its sea traffic the adoption of special mandatory methods for the prevention of sea pollution is required (IMO, 2009h)*

¹¹ *PSSA is an area that needs special protection through action by IMO because of its significance for recognized ecological or socio-economic or scientific reasons and which may be vulnerable to damage by International maritime activities (IMO, 2009i)*

depth (Clark, 2001). With an average depth of only 57 metres and a max depth of 459 metres (Walday & Kroglund, 2003), the Baltic Sea is much shallower than most of the world's seas. In fact, shipping activities in this area create one of the busiest traffic lanes in the world. More than 3,500 ships monthly operate in the Baltic Sea which accounts for 15% of the world's cargo transportation (HELCOM, 2008, p. 69). According to HELCOM, the number of ships navigating in the Baltic Sea will grow to accommodate an increase in cargo amount in 2020 by 64% from 731 million tons in 2003. Undoubtedly, the growth of shipping activities threatens the environment in the Baltic Sea and 85 million inhabitants in this region.

Ships of more than 500 GRT emitted in 2000, NO_x, SO₂ and PM quantities of roughly 299 kilotons, 212 kilotons and 24 kilotons respectively (Cofala, Amann, Heyes, Wagner, Klimont, Posch, Schöpp, Tarasson, Jonson, Whall, & Stavrakaki, 2007, p. 10). In the case of NO_x, EU commission reported NO_x may increase by two-third for two decades from 2000 to 2020, although Annex VI has been implemented. The excessive NO_x emissions in the air will threaten the biodiversity and nature protection in the Baltic Sea.

NO_x is one source of eutrophication in the Baltic Sea besides sewage discharge contains excessive nitrogen from rivers and cities around the sea. Approximately a quarter of the total nitrogen deposit in the Baltic Sea is released from ships and 40% is airborne compound of NO_x from distant sources outside the sea (HELCOM, 2005, p.3). Obviously, NO_x emissions are carried mainly by westerly winds to the south western and southern parts of the Baltic Sea.

According to Pawlak, Laamanen & Andersen (2009, p.5), the research found that 161 coastal areas were affected by eutrophication from 172 coastal areas in the Baltic Sea. It means that more than 90% of coastal areas were affected by eutrophication. Several indicators of eutrophication occur in the Baltic Sea such as cyanobacteria which have covered beaches in the northern Baltic and in the Baltic Proper (HELCOM, 2006, p.16). Several problems arise including inconvenience for recreational activities, reduced water transparency and low oxygen level in the Baltic

Sea. It is crystal clear that eutrophication has great impact on the tourism industry and the marine ecosystems in the Baltic Sea.

According to Andresson, Håkansson, B., Håkansson, J., Sahlsten, Havenhand, Thorndyke and Dupont (2008, p.19) airborne sulphur deposition is larger in the southern Baltic. Ocean acidification is not only because of CO₂ and NO_x emissions but also acid rain caused by SO_x emissions (Doney, Mahowald, Lima, Feely, Mackenzie, Lamarque & Rasch, 2007). In general, ocean acidification is a process of the ongoing decreasing pH of sea water which primarily affects oceanic calcifying organisms. As Dupont wrote, "Acidification in Swedish coastal waters caused rapidly 100% mortality of a common brittlestar and ophithrix fragilis" (as cited in Andersson et al, 2008 p. 27). The negative impact of acidification, found at earlier research will threaten calcifying species in the future.

Loss in human life expectancy is associated with anthropogenic emissions of PM_{2.5} from ships. The average loss of life expectancy caused by shipping in EU's 27 member states was 8 months in 2000 (Cofala et al, 2007, p. 39). However, most Baltic countries loss of life expectancy was below this average, such as Finland (2.94 months), Sweden (3.40 months) and Norway (2.53 months). It can be understandable because the shipping traffic density in the northern Baltic Sea is lesser than traffic density in other parts of European seas.

According to Corbet et al (2007, p.40) premature mortalities in Europe and Mediterranean region was 26,710 deaths in 2002. In this regard, PM_{2.5} emissions from ships navigating in seas around European and Mediterranean countries such as the Baltic Sea, the North Sea and the Mediterranean Sea contribute to the mortality. Consequently, health care is a vital service provided by the public and private sectors in those countries to treat illness from severe ship emissions. It is however costly. For instance, Danish Environmental Agency estimated that shipping emissions cost the Danish health service over 4.5 billion euro annually, mainly in curing cancers and heart problems (Transport & Environmental Bulletin, 2009). A strategy to reduce emissions from the shipping industry and other land based

pollution sources is extremely important. Perhaps, monetized health benefits will largely outweigh both emissions reduction cost and illness treatment cost.

2.4.2. The North Sea and the English Channel

The North Sea is constricted at the Strait of Dover and the English Channel in the southern end and the northern boundary can be regarded as a vertical line from the northern coast of Great Britain and a straight line from the Norwegian coast near Bergen. The greater North Sea has an area of about 750,000 km² and a volume of about 94,000 km³ (Vlasblom, 2006, p.51). It is including the English Channel and the straits of Dover with their estuaries and fjords. It is relatively shallow (average depth is 90 m), but also includes deeper water of 700 m such as the Norwegian Trench (Ducrotoy & Elliot, 2008, p.9).

The North Sea and English Channel are heavily trafficked sea lanes. Recently, shipping traffic density in the North Sea is more than 400,000 ship movements yearly (Sea Watch Foundation, 2009). Particularly in the Dover Strait, there are more than 400 commercial shipping movements daily (Maritime Coastguard Agency [MGA], 2009). The consequence of the dense ship traffic is that the North Sea is vulnerable to marine pollution caused by deliberate oil, sewage and garbage¹² discharges and oil leakage accidents as well as air¹³ pollution from ships.

In the year 2000, ships of more than 500 GRT released NO_x, SO₂, and PM compounds of approximately 693 kilotons, 496 kilotons and 59 kilotons (Cofala et al, 2007, p.10). In comparison with the Baltic Sea, the emissions inventories in the North Sea are more than twice. It is understandable because inventory prediction was calculated based upon several factors, such as the number of ship movements in the sea. In fact, the number of ships navigating in the North Sea is larger than in the Baltic Sea as stated above.

¹² IMO has designated North Sea as special area for preventing garbage pollution under Annex V of MARPOL 73/78

¹³ IMO has designated North Sea as special area (ECA) for preventing air pollution under Annex VI of MARPOL 73/78

It was predicted that 90% of the total SO₂ and NO_x substances which contaminate the North Sea including the English Channel originate from a zone of approximately 50 nautical miles (The EEB et al, 2004, p.3). SO_x forms acid rain that changes chemical composition of land and water which leads to acidification affecting forest ecosystems. For example, acid deposition above critical load occurs in several forests such as in Germany (62,491 km²), UK (9424 km²) and Belgium (4591 km²) (Cofala et al, 2007, p.45). Acid deposition on land impairs tree growth and even kills them because it washes away essential minerals and nutrients for plants.

It should be noted that life expectancy is one indicator of the adverse effect of PM_{2.5} emissions to human health. Although according to Cofala et al (2007, p.40) the average of life expectancy in EU's 27 member states was 8 months in the year 2000, several countries bordering the Greater North Sea experienced loss of life expectancy over the average such as the Netherlands (11.51 months) and Belgium (12.17 months) except the UK (6.71 months). It can be concluded that the air quality related human health in Northern European countries bordering the Baltic Sea is better than aforementioned countries because of ship traffic density factor. If the Arctic Sea Route will be an attractive shipping lane to connect Europe and Asia in the coming years, the degradation of air quality in Northern Europe may happen and result in a decrease in life expectancy.

2.4.3. The Mediterranean Sea

The Mediterranean Sea is the largest semi enclosed European sea and consists of a narrow shelf, a small drainage basin and a narrow littoral zone (Figure 2.4). The Mediterranean Sea has an area of 2,965,000 km² and deep water with more than 200 m in average depth and a number of deep basins below 3000 m (Clark, 2001, p. 206). The Sicilian Channel separates the eastern and western Mediterranean with distinct geographical and hydrological characteristics between them. The coastal length of the Mediterranean Sea is approximately 46,000 km (European Environmental Agency [EEA], 2006, p. 10) which is occupied with a population dense in 601 cities and receives 175 million tourists a year (Abdulla & Linden, 2008, p. 7).



Figure 2-4. The Map of Mediterranean Sea

Source: http://www.welt-atlas.de/map_of_mediterranean_sea_4-634

The sustainability of tourism industries is dominantly influenced by garbage pollution and ships are one pollutant source. Consequently, the Mediterranean Sea has already been designated as special area under Annex V of MARPOL 73/78. However, special area (ECA) for preventing air pollution under Annex VI has not been submitted yet to IMO. Today, the preparation required for submission of an application to IMO has been carried out under the auspices of Regional Marine Pollution Emergency Response Centre for the Mediterranean Sea (REMPEC) (Meech, 2005)

The Mediterranean Sea is a very important maritime transport route which connects the Atlantic Ocean through the strait of Gibraltar and the Red Sea and the Indian Ocean through the Suez Canal. Lloyd's Marine Intelligence Unit recorded the movement of all ships above 500 GT to around "250,000 movements in the Mediterranean in 2005 augmented by an additional 100,000 ferry movements" (as cited in Meech, 2005, p. 55). This database did not count movements of naval ships, fishing vessels and small craft that were excluded from estimation of emission inventories. However, those ships are enough to generate air emissions which will have an impact on marine biodiversity and human life.

In 2000, ships of more than 500 GRT released NO_x, SO₂, and PM compounds of approximately 1781 kilotons, 1251 kilotons and 151 kilotons respectively (Cofala et al, 2007, p.10). The emission inventories in the Mediterranean Sea are larger than those in the Baltic Sea and the North Sea. Surprisingly, although the number of ship movements in the Mediterranean Sea is lower than in the North Sea, the emission inventories in the Mediterranean Sea are more than twice. Thus, there is another factor that influences the emission inventories in the Mediterranean Sea. Perhaps the emissions in the Mediterranean Sea also are influenced by land based polluters.

The most prominent seas for maritime transport suffer eutrophication from NO_x released from ship engines. A study (EMEP/MSC-W, 2000) found that “ship movements contributed to over 50% of exceeded critical loads for nutrient formed by nitrogen in the coastline of Spain, Italy, Greece and Croatia” (as cited in EEA, 2006, p. 51). Harmful algal blooms, which were caused by excessive nutrients, occur in the Mediterranean Sea leads to fish kills and toxic effects on humans. Fish mortality is the main impact of eutrophication caused by poisonous algal blooms and the effect of oxygen depletion in the water. Contaminated seafood, which is infected by Seafood Toxin Blooms (STB), consumed by humans cause sickness.

Destruction of forests on the coastal area of the Mediterranean Sea is influenced by acid rain. Forest soils are located in several Mediterranean countries with larger acid deposition above the critical load found in France (19,649 km²) followed by Greece (943 km²) and Spain (900 km²) (Cofala, 2007, p. 45). The large area of forests, which could be damaged by acidification, will affect the entire ecosystem in that area. Animals rely on forests in terms of food source and important habitat. Furthermore, the risk of flood and soil slide is enormous since intensive hard rain could not be absorbed effectively by few trees which will threaten inhabitants nearby.

2.4.4. The US and Canadian waters

US coastlines consist of the Pacific Coast and the Atlantic Coast where the Pacific Ocean borders the US in the west and the Atlantic Coast borders the US in the east. The Atlantic coast spans from Maine to southern Florida with many large bays and numerous rivers, whereas the Pacific coast has peninsulas, islands and fjords. The

total of US coastlines is 12,383 miles including Alaska (6,640 miles) and Hawaii (750 miles) (U.S. Census Bureau, 2009, p. 214) while Canada is the world's longest coastlines approximately 243,000 km as well as the second largest EEZ (Canada's Federal Marine Protected Areas Strategy, 2005, p.4).

With the long coast lines, the US and Canada waters are intensively sailed by merchant vessels to and from Asian, European and inter American ports. More than 93,000 ships sail to and from the US and Canada ports annually, comprising 64,000 ships (>10,000 DWT) in the US ports and 29,000 ships (>400 GRT) in the Canadian Ports in 2008 (IMO, 2009b, p.51). In particular, according to another research conducted by Wang, Corbett, and Firestone (2007, p. 3226) the ship (> 1000 GT) movements from and to the North American ports were predicted to roughly 172 thousand voyages in 2002. In fact, emissions are released to the US and Canadian atmosphere not only from those ships but also from certain ships passing US and Canadian waters to and from other ports outside US and Canada. Consequently, the amount of emissions based upon such database is probably underestimated.

Despite the estimation might be under expectation, emissions over the US and Canadian air will almost double in the period of 18 years. Wang et al's work predicted approximately 700,000 tonnes of NO_x, 400,000 tonnes of SO_x and 58,000 tonnes of PM emissions were produced by ships navigating within the US and Canadian Economic Exclusive Zones in 2002. In 2020, the figures may rise to roughly 1.3 million tonnes of NO_x, 969,000 tonnes of SO_x and 115,000 tonnes of PM (IMO, 2009b, p.15). These Emission calculation employs "no action" scenario, which means there is no emission reduction standard of ships operating within the US and Canadian EEZ between 2002 and 2020.

The implication of "no action" scenario is obviously damaging to the environment and human beings. Ship emissions contributes to 30% of the nitrogen in the Chesapeake Bay in the Mid Atlantic coast of the US which leads to acidification (IMO, 2009b, p.4), for example, approximately 580 of the streams in the Mid Atlantic Coastal Plain make the water more acidic (Environmental Protection Agency [EPA], 2009a). Acid deposition impairs the growth of aquatic plankton which makes crayfish,

shellfish and various types of fish to disappear. The same situation occurs in eastern Canada where aquatic micro organism growth as essential food source for fish is devastated (IMO, 2009b, p.5). Some fishes which are sensitive to acid will be killed gradually such as brook trout, walleye and salmon. For example, Atlantic salmon population in rivers of the Southern Upland region of Nova Scotia is severely affected by acid rain. The acidification effect has decreased the adult salmon population from 45,000 to less than 5,000 in the areas 57 rivers (Purcell, 2007, p.1).

The number of premature mortality caused by PM_{2.5} and ozone emissions will account for 5,100-12,000 deaths in 2020 (EPA, 2009b, p.6). To some extent Corbet's research (2007, p.8515) estimated that the premature mortality related to PM_{2.5} will reach 5,100 deaths in 2012 in North America earlier than previous estimation. The latter prediction will augment if the effect of ozone on human health is considered. Diverse prediction of premature mortality can be comprehended by taking account of different methodology and databases but the essential result is that PM_{2.5} and ozone impact on human health might not be eluded. Consequently, harmful emissions will endanger 330 million lives of US and Canadian inhabitants which are over half the population living along the Atlantic and the Pacific coastline (IMO, 2009b, p.2), if there is no substantial initiative from both governments to lessen adverse consequences. Accordingly, the US and Canada submitted a joint proposal to IMO to designate their coastal area as an ECA.

2.4.5. The Straits of Malacca

The Straits of Malacca is located between the west coast of the Malaysian Peninsula and the east coast of Sumatera Island and it is connected with the Straits of Singapore at its south east end (Figure 2.5). The length of the strait is approximately 600 nm with the widest section (220 nm) at the northwest entrance then gradually narrowing to around 8 nm at the south east entrance near the Riau archipelago (Thia-Eng, Gorre, Ross, Bernad, Gervacio & Ebarvia 2000, p.160). The Strait of Malacca is a shallow area with an irregular depth from 17 m to 55 m (Thia-Eng et al, 2000, p.160) and the tidal variations of water levels ranging from 1.6 m to 3.7 m (Kullenberg, 2008).

within the straits and there is no intergovernmental declaration issued by littoral straits to protect the Straits of Malacca from air pollution. The fact that emissions from shipping contributed to ecological damage in areas surrounding the straits has been acknowledged by scholars, therefore this issue should be taken into account by the parties concerned.

According to Street, Carmichael, & Arndt (1997, p.1576), the Straits of Malacca have been contaminated by SO₂ emissions amounting to between 40,000 and 60,000 tonnes per year. SO₂ emissions create acid deposition that is believed to be a risk for damage to ecosystems in the Straits of Malacca such as coral reefs, soft bottom habitats and its neighbouring lands including estuaries and mangrove forests. In particular, the mangrove forest along the Straits of Malacca was estimated around 447, 680 ha and 385,000 ha located in the Riau province of Indonesia (Thia-Eng et al, 2000, p.162).

Since SO₂ emissions create acid deposition, Streets, Guttikunda and Carmichael (2000, p.4431) predicted a deposition increase from 66 to 112 mg Sm⁻²yr⁻¹ in the coastal areas of the Strait of Malacca between 1988 and 1995. The amount of acid deposition in 1995 was predicted to increase in the recent years. If there are no adequate measures to mitigate environmental impacts of air pollution from ships, the damage of the Straits of Malacca ecosystems may have already occurred. In fact, neither the special area under MARPOL 73/78 nor PSSA according to IMO resolution are given to the Straits of Malacca to protect its environmental ecosystems. Accordingly, the littoral states should take any appropriate measures for example submitting joint proposal regarding special areas and PSSA to IMO. The fact that the straits of Malacca is the prominent oil supply route and having the worst air quality in South East Asian Waters could convince IMO member states to include the strait as special area under Annex I and Annex VI.

2.5. Conclusion

The economic crisis has caused a decrease in the volume of international trades which resulted in ships being laid up with around 10% of world fleet in 2009 especially for bulk carries and container ships. The ship traffic density was captured

by AMVER in June 2009 which shows that most ships concentrate in coastal areas. Furthermore, ICOADS approximate 70% of ships traffic occurs within the EEZ and then gradually decreases by 36% of ships when approaching 25 nm from the coastline.

The number of ships and traffic is associated with ship emission inventories. There is a tendency that emission inventories will increase in the forthcoming years. It is possibly because the Annex VI is less stringent to control ship emissions than similar regulations for other transport modes. Furthermore, the low quality of fuel oil, which is high low sulphur content in fuel used by most vessels, is the root cause of airborne pollution.

Airborne emissions namely NO_x, SO_x and PM cause acidification, eutrophication and premature mortality especially in the Baltic Sea, the North Sea, the Mediterranean Sea and the US and Canadian waters. The Mediterranean Sea is the most affected area by air pollution from ships. In 2000, the emissions of NO_x, SO_x and PM in the Mediterranean Sea were more than twice and five times as many as those in the North Sea and in the Baltic Sea respectively. However, the ECA proposal, which designates the Mediterranean Sea as ECA, has not yet been submitted to IMO.

In the US and Canadian waters, the emissions of NO_x, SO_x and PM were estimated to roughly 700 kilotonnes, 400 kilotonnes, and 58 kilotonnes respectively in 2002. These figures are relatively the same as the amount of North Sea emissions in 2000. These emissions are expected to be minimized by designating the US and Canadian waters as ECA.

In the case of the Straits of Malacca, although air emissions are the real problem in the straits, there is a limited number of research concerning air emission inventories and there is no joint initiative from littoral states to protect the strait from air pollution. Consequently, the littoral states play an important role in the international forum to propose the straits as special area for air emission reduction.

CHAPTER 3

EMISSION CONTROL AREA

3.1. The Background of Annex VI of MARPOL

The initiative of sulphur emission reduction was discussed in meetings long before IMO decided the sulphur cap in 2005. The purpose of the meetings was mainly triggered by the effects of acid rain on crops and forest devastation induced by airborne pollution of SO_x compounds. The 1972 United Nations Conference on the Human Environment in Stockholm deliberately made efforts to alleviate acidification through international cooperation. It was followed by the Convention on Long-range Transboundary Air Pollution which was adopted in Geneva in 1979. Various legally binding protocols have been agreed concerning sulphur emission control and reduction in 1985 and 1994, controlling emissions of nitrogen oxides in 1988 and controlling emissions of volatile organic compounds in 1991 (IMO, 2009e).

In the regional forum, the Second International Conference on the Protection of North Sea was held in London, 24-25 November 1987. It was attended by ministers from eight countries who were responsible for the protection of the North Sea. The conference initiated efforts to improve quality of heavy fuel standards and to reduce airborne pollution within the international bodies concerned. The declaration convinced IMO to put air pollution issues into the Maritime Environment Protection Committee (MEPC)¹⁴ agenda towards adoption of Annex VI through a protocol to the MARPOL 73/78 in 1997, which entered into force on May 19, 2005. As at 31 July 2009, 56 countries representing over 83% of the world's tonnage have become parties to MARPOL Protocol 1997 Annex VI (IMO, 2009h).

¹⁴ *The issue of air pollution was included in the IMO agenda in 1988 following the submission of the air pollution problem from Norway Delegation. The next MEPC was held in 1989 to address issues related to fuel oil quality and airborne pollution.*

3.2. Emission Control Area

3.2.1. The Background of Emission Control Area

The IMO member states acknowledged the low quality of heavy fuel in connection with the high sulphur content of fuel onboard ships. The low quality fuel oil is producing exhaust fumes such as SO_x that leads to acid rain. Accordingly, the most straightway form of reducing acid rain effects is to switch higher sulphur fuel oil to lower sulphur fuel oil.

The above issue was discussed during MEPC meetings and raised two main topics, namely the area of sulphur emission control and the amount of sulphur content to be reduced in these areas. The Baltic Sea Countries such as Finland, Sweden, Russia and Poland preferred a global coverage of sulphur emission control but the consequences of global sulphur control area were high due to the availability of low sulphur fuel, the high cost of fuel desulphurisation and subsequent economic implications.

Although a global sulphur control area could not be accepted, the Baltic countries under the auspices of the Helsinki Commission (HELCOM) Convention requested the recognition of the Baltic Sea as a “special area” under the new Annex VI (HELCOM, 1994) which is applicable to all IMO member states and not only ships from HELCOM contracting parties. Finally, MEPC 53rd session in July 2005 adopted a “special area”, which was called SO_x Emission Control Area (SECA) which set forth sulphur content in the fuel to maximum 1.50%.

Nevertheless, the sulphur cap within SECA creates law discrimination and precipitates economic disadvantages. Ship owners must comply with more stringent regulation which is not applicable to their competitors in other parts of the world, which in turn will bring financial comparative disadvantage in terms of voyage cost. Accordingly, proponents of global sulphur control areas offered the global limitation of sulphur content in fuel oil. After difficult negotiation, the conference unanimously accepted sulphur content in fuel to be not more than 4.50%. However, this figure was higher than the average sulphur content in fuel at that time and it emerged

considerable controversy (Nielsen, 2000, p.18). In fact, this figure was an acceptable limit, which is slightly lower than the maximum limit of sulphur in fuel oil (5.00%) according to International Standardization Organization (ISO) 8217 specification.

3.2.2. Emission Control Area (ECA) Criteria

The current Annex VI enables a party or joint parties to submit designated specific areas of coastal waters as SECA to limit emissions of SO_x. The proposal of SECA is submitted to IMO including compliance of six SECA criteria. The criteria cover the geographical area of SO_x emission control, a description of SO_x impact on land and sea, an assessment of SO_x contribution to air pollution, meteorological condition description, ship traffic density and control measures to be taken by the proposing parties.

Nevertheless, a special area is not solely applicable to SO_x emissions since MEPC at the 58th session in October 2008 amended criteria on Appendix III of Annex VI. The revised criteria offer SO_x or NO_x or PM or all three types of pollutants to be restricted in the respective area which will entry into force in 2010. Since NO_x and PM emissions can be introduced in the designated area, therefore, the Emission Control Area (ECA) is now the right terminology to include also emissions other than SO_x.

The amendment to Annex VI obliges the party or joint parties to meet eight criteria in an ECA proposal, whereas the current Annex VI requires six criteria. In this regard, two additional criteria of ECA cover emission type(s) which is/are being proposed within ECA and emission reduction cost and economic impact on international shipping. The former criterion enables ECA to limit SO_x or NO_x or PM or all three types of emissions. The latter criterion concerns the economic feasibility of the regulation. The desirability of regulations can be assessed by various economic impact analysis (Mukherje & Xu, 2008), because regulation implementation will incur additional cost to industries. Economic impact analysis may employ cost benefit analysis to identify the effectiveness of forthcoming regulation. Consequently, the

analysis should confirm the benefit of recovered air quality outweighing the cost of emission reduction to ensure the regulation is feasible to be implemented.

The rest of the ECA criteria adapt to the additional emissions other than SO_x. For example, one criterion emphasizes human population and environmental description at risk of shipping emission. The human population is pertinent to the PM effect on the population, who live in coastal areas and suffer from PM induced by ships. Furthermore, the environment is an appropriate terminology to replace land and sea in the current SECA criteria.

3.2.3. The Baltic and North Sea SECA

The Baltic Sea, which was designated as the first SECA in MARPOL Protocol 1997 Annex VI, prohibited the use of residual fuel oil with sulphur contents exceeding 1.50% from 19 May 2006. The same standard was agreed at MEPC 44 in 1999 for the North Sea and came into effect on 22 November 2007. Alternatively, exhaust gas cleaning systems can be installed onboard that restrict the emission rate to 6.0 g/kWh or use other technology to limit SO_x emissions. The SECA delineation of the Baltic and the North Sea (Figure 3.1) has the same delineation as in Annex I and Annex V respectively to provide comprehensive enforcement of oil pollution, garbage management and air pollution. Undoubtedly, it will simplify the control and detection of regulation violations.

According to Annex I of the International Convention for the Prevention of Pollution from Ships (MARPOL 73/78) (2006, p. 47), the Baltic Sea means “the Baltic Sea proper with the Gulf of Bothnia, the Gulf of Finland and the entrance to Baltic Sea bounded by the parallel of the Skaw in the Skagerrak at 57°44'.8 N.” While the North Sea is defined in Annex V of MARPOL 73/78 (2006, p. 319) as follows:

The North Sea proper including seas therein within boundary between: the North Sea southwards of latitude 62°N and eastwards of longitude 4°W, the Skagerrak, the southern limit of which is determined east of the Skaw by latitude 57°44'.8 N, and the English Channel and its approaches eastwards of longitude 5°W and northwards of latitude 48°30' N.

The abovementioned definition of the Baltic Sea and the North Sea delineates the SECA border is depicted in Figure 3.1.

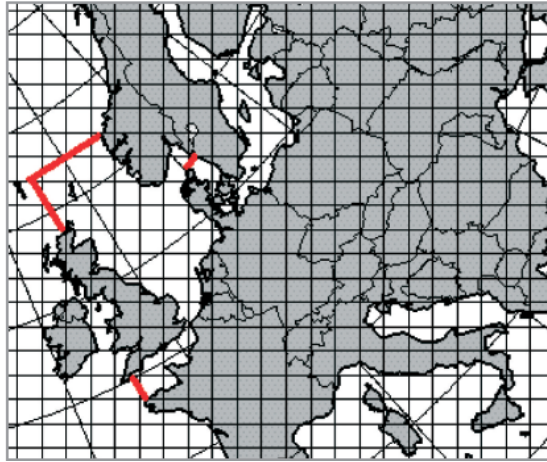

Figure 3-1. The SECA delineation of the Baltic and the North Sea

Source: Det Norske Veritas. (2006). *MARPOL Annex VI operation in SO_x Emissions Control Areas, how to comply*. Oslo: Author.

3.2.3.1. Relevant SO_x emission regulations

The European Union (EU) imposed the aforementioned standard from 11 August 2006 for the Baltic Sea and 11 August 2007 for the North Sea through EU Directive 2005/33. According to the EU, final enforcement dates for SECAs between IMO and Directive 2005/33 could not be precisely aligned because of the nature and timing of different legislative processes. The directive has also regulated the use of maximum 1.50% sulphur fuel for passenger vessels on regular service from and to European ports since 11 August 2006 and vessels at berth with minimum duration of 2 hours must use 0.10 % sulphur fuel effectively from 1 January 2010. It is an additional mitigation of SO_x while ships berth in harbours, even though ships consume less fuel (only generating electricity). The EU Directives concerning sulphur content limitation in fuel oil can be seen in Appendix C.

3.2.3.2. The impact of SECA on ship operations

Some ships, which operate exclusively in the Baltic Sea, have consumed fuel oil with a sulphur content which is lower than the SECA requirement. For example,

passenger ferries between Sweden and Finland use fuel that has significantly less sulphur, around 0.50% and even less. According to Corbett & Farrell (2002), some 65% of the ferry tonnage has switched to lower sulphur. These facts show that passenger ferries navigating regularly in the Baltic Sea did not like to experience problems when SECA was introduced in this area. However, problems will arise when all vessel-at-berth and inland waterways operations must consume 0.10% sulphur content in fuel from 2010 as per EU Directive 2005/33/EC. These vessels will probably either carry two types of fuel for their operation or they will be installed with onshore power supply which enables them to use electricity sources from the ports during berth operations.

An obvious problem is ships trading into and out of SECA because they have to operate with dual fuel oil systems (sulphur content less than 1.50% and 4.50%). The dual system operation has serious implication to engine condition, change over operation, lubrication complexity and tank segregation. Furthermore, the price of lower sulphur fuel is another problem because it is relatively costly. It is likely that the fuel cost for ships navigating in the SECA will increase. BMT (1999) estimated that “such a premium for low sulphur fuel would lead to increased running costs for ships operating in the North Sea SO_x control area of about \$330 million” (as cited in IMO, 1999, p.9).

The fuel cost will influence the total operational costs and make shipping operation unattractive. However, the International Institute for Applied Systems Analysis (IIASA) concluded that the marginal cost associated with SO₂ reduction (0.5 euro per kg SO₂) for ships operating in the North Sea was compared favourably with land based sources (1.5 euro per kg SO₂) (as cited in IMO, 1999, p.8). It means that the reduction of SO₂ emissions in shipping is relatively cheaper than the land based. Thus, it ensures the sulphur reduction scheme under SECA is reasonable.

3.2.3.3. The Benefit of the Baltic and the North Sea SECA

Some statistics show the increase in SO_x emissions within SECA both in the Baltic and the North Sea (Figure 3.2). According to IMO (2009c, p.58), emissions of SO_x from shipping in the SECA had been reduced by about 42%, corresponding to 700

kilotonnes, in 2008 when the SECA regime was applied effectively. It will go up to 800 kilotonnes in 2010 (CONCAWE, 2006). Two figures show there will be an increase in the amount of SO_x emissions over two years, despite the fact that Annex VI is fully in force.

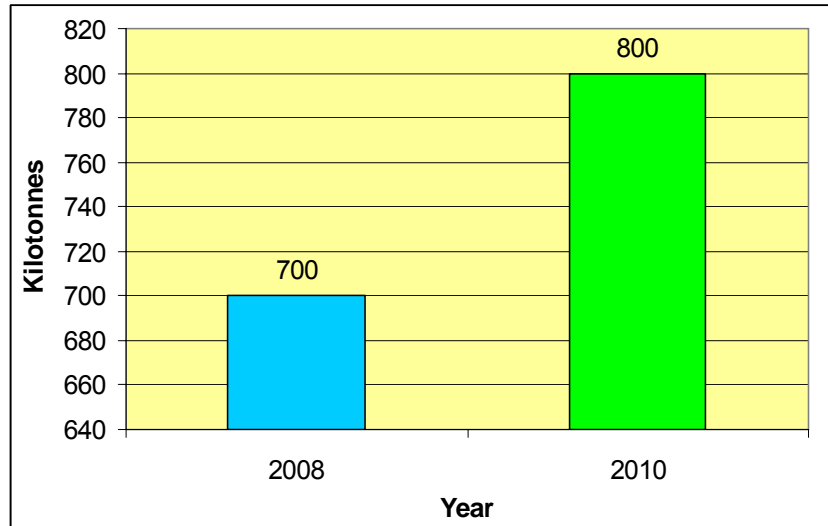

Figure 3-2. The estimation of SO_x emissions within the Baltic and the North Sea SECA

Source: The SO_x emissions in 2008: International Maritime Organization. (2009, April 9). *Second IMO GHG Study 2009 Update of the 2000 IMO GHG Study Final report covering Phase 1 and Phase 2: noted by Secretariat* (MEPC 59/INF.10). London: Author.

The SO_x emissions in 2010: CONCAWE. (2006). *Techno-economic analysis of the impact of the reduction of Sulphur content of residual marine fuels in Europe* (Report No. 2/06). Brussels: Author.

Nevertheless, the benefit of SECA can be perceived in the long term period. Recent research has been conducted to predict the benefit of SECA implementation to environment and human health (Cofala et al, 2007). For example, it will lower acidification of forests from 800,000 km² in 2000 to 688,000 km² in 2020. Furthermore, loss of human life expectancy can be reduced from 8 months (2000) to 5 months (2020). However, those benefits are estimations on paper and different findings may emerge depending upon estimation methods and assumptions.

3.2.4. The forthcoming ECA: US and Canadian Waters

The US and Canada have worked together since 2006 to formulate an ECA plan and to submit the ECA proposal to IMO in March 2009. This plan is designed to comply with the requirement of the ECA criteria of Annex VI. In this regards, it

attempts to lessen SO_x, NO_x and PM at once from ocean going ships operating within 200 nm from US and Canadian coastal baselines. The ECA proposal includes the Pacific Coast area from Anchorage to the southernmost boundary between California and Mexico, the Atlantic/Gulf Coast from Atlantic Coast of the US and Canada to the border of Texas with Mexico and eight main Hawaiian Islands (Figure 3.3). The ECA delineation covers the EEZ of the US and Canada except it would not extend into marine areas subject to the sovereignty, sovereign rights or jurisdiction of any state other than US and Canada (EPA, 2009b, p.2).

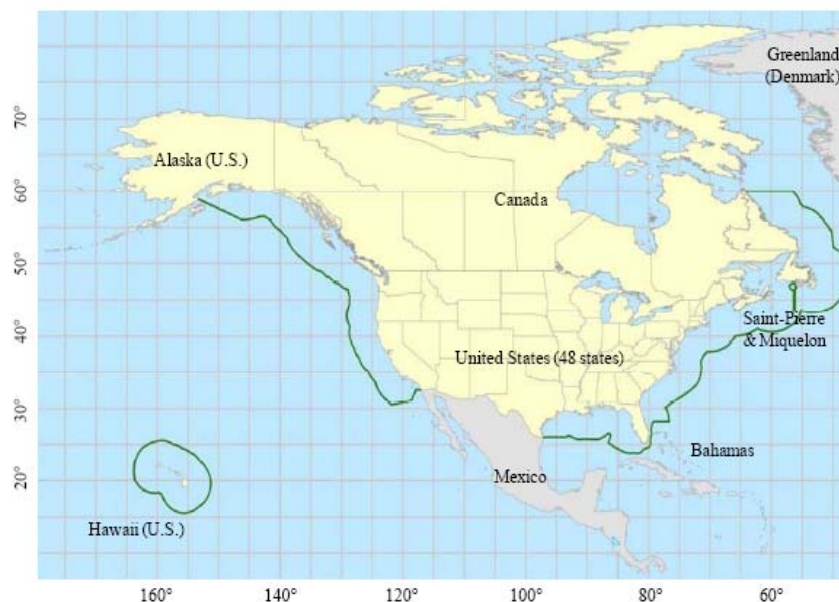

Figure 3-3. The ECA delineation of EEZ US and Canada

Source: EPA. (2009b). *Proposal of Emissions Control Area Designation for Geographic Control of Emissions from Ships*. Retrieved June 10, 2009 from the World Wide Web: <http://www.epa.gov/oms/regs/nonroad/marine/ci/420f09015.htm>

In July 2009, ECA proposal was reviewed during MEPC 59th session towards formal adoption in March 2010. In this regards, MEPC 59th session agreed to amend regulation 13 and 14 of Annex VI (IMO, 2009d). The implementation of US and Canadian waters ECA is expected to enter into force in August 2012.

3.2.4.1. Relevant NO_x, SO_x and PM emission regulations

In March 2008, EPA adopted more stringent standard to reduce NO_x and PM emissions from small marine diesel engines below 30 litres per cylinder displacement (category 1 and category 2). This standard entered into force on July, 7 2008. It is expected to lessen NO_x emissions by as much as 80% and PM emissions by as much as 90% when fully implemented (EPA, 2009c).

In 2003, EPA adopted a tier 1 standard for category 3 (marine diesel engines above 30 litres per cylinder displacement) to reduce NO_x emissions from ocean going vessels. The tier 1 of EPA standard is equivalent to regulation 13(3)(a) of Annex VI. In addition to the proposed ECA designation, EPA has issued a plan to provide more stringent reduction standard for NO_x (tier 2 and tier 3 standard), PM and SO_x emissions through abatement technologies and low sulphur content in the fuel. The new regulation is expected to be finalized in December 2009.

In December 2005, California State has so far adopted the regulation of SO_x, NO_x and PM emission reduction in auxiliary diesel engines and diesel-electric engines in ocean going vessels within 24 nautical miles of the Californian coastline. The regulation imposes the use of 0.50% sulphur fuel oil or other equal emission controls. The standard has been amended several times to reduce sulphur content in the fuel gradually (Appendix D)

In the case of Canada, a provision regarding emissions from ocean going vessels exists especially for cruise ships since 2005, namely the Pollution Prevention Guidelines for the Operation of Cruise Ships under Canadian Jurisdiction. It is only regulating sulphur content in the fuel, emissions from incinerators and halocarbons. In addition, the Canadian Act only addresses the emissions of black smoke in Canadian waters and within 1 mile of land (Appendix E).

3.2.4.2. The impact of ECA on the ship operations

Once ECA has been adopted by IMO member states, the countries should follow the IMO scheme to downgrade the sulphur content in fuel gradually until 2020.

Consequently, the availability of LSFO is a major issue in ECA implementation. For this purpose, EPA confirms LSFO (1.00%) available within the US ECA (Scott & Sinnamon, 2009, p.2). Therefore, Canada should also be able to provide adequate LSFO in the ports in its territorial waters. Since the scheme requires more stringent control of sulphur content in fuel to 0.10% from 2015, the projection of fuel consumption by 2020 is necessary to warn oil refinery industries concerning the high demand of low sulphur fuel.

Table 3-1. The total cost of compliant SO_x and NO_x emission regulation

Type Of Cost	Compliance Strategy	Cost in 2020 (Billions USD)
Operating Costs (apply to all ships)	Fuel Switching	\$ 1.9
	Urea consumption (For SCR-equipped engines)	\$ 0.17
Hardware Costs (apply to ships built in 2020)	Fuel Switching	\$ 0.03
	SCR	\$ 1.1
Total Costs		\$ 3.2

Source: International Maritime Organization. (2009a, March 27). *Proposal to Designate an Emissions Control Area for Nitrogen Oxides, Sulphur Oxides and Particulate Matter Submitted by the United States and Canada. (MEPC 59/5/X)*. London: Author.

In regard to preparation of the forthcoming ECA, the ship owners should cogitate whether or not retrofit is required to meet the ECA standards. The retrofit of ships may require upgrading equipment and systems related to the SO_x, NO_x and PM emission reduction. The reduction of SO_x and PM fumes is straightforward to use LSFO, but appropriate systems and adequate tanks are needed. The retrofit is also relevant to NO_x emission control by installing abatement technologies.

Table 3.1 shows that operating costs will attribute to the total costs to comply with ECA standard. For existing ships, it will roughly be US\$ 2.07 billions in 2020, while the new building ships will spend US\$ 3.2 billions to install appropriate hardware and to use distillate fuel and urea in 2020. Unfortunately, the analysis solely assesses Selective Catalytic Reduction (SCR) among many alternatives of the NO_x abatement technologies such as Humid Air Motor (HAM) and Direct Water Injection

(DWI). Consequently, there is a possibility to find a better option from untapped technologies in terms of technical and economical feasibility. Furthermore, IMO requires tier III to reduce NO_x emissions within ECA, which will enter into force in 2010, while global sea areas will implement tier II. Consequently, IMO should stipulate the further standards of NO_x emission reduction within ECA and their time frame after tier III has been implemented because recently there is no long term of IMO planning with regard to NO_x emission reduction. Further information regarding tier I, II, III is presented in Appendix F.

The end result of ECA impacts is the transportation cost. The implementation of ECA will increase the freight rate of goods and passengers carried by ships. It is influenced by switching from residual fuel to distillate fuel, which leads to incremental voyage cost. However, the analysis of the economic impact shows that ships engaged in ECA will suffer modest impact. For example, the costs of shipping a twenty-foot-equivalent container will increase by about US\$ 18 between Singapore, Seattle and Los Angeles/Long Beach (IMO, 2009b). Moreover, the same calculation for the per passenger price of a seven-day Alaska cruise operating entirely within ECA will increase about US\$ 7 per day. Nevertheless, ships passing over ECA from and to outside US and Canadian ports may experience higher incremental voyage costs significantly considering travel distance, unless ships avoid affected ECA.

3.2.4.3. The Benefit of US and Canadian Waters ECA

The benefit of ECA can be reviewed through the amount of emission reduction, the cost effectiveness and the quality of human health. In 2020, the ECA can reduce approximately 294,000 metric tonnes of NO_x, 85,400 tonnes of PM_{2.5} and 834,000 tonnes of SO_x (IMO, 2009b). The potential reduction of emissions will definitely be associated with the cost to provide cleaner fuel, additional tanks and abatement technologies. These costs are calculated in the form of cost effectiveness as follows: about US\$ 2,600 per tonne of NO_x removed, US\$ 11,000 per tonne of PM_{2.5} removed and US\$ 1,200 per tonne of SO_x removed (IMO, 2009b). Although this estimation is conducted within the US ECA, cost effectiveness in Canada may relatively be under the same performance. Furthermore, the cost effectiveness of ship emissions outweighs land based sources. For example, to clean up the exhaust emissions

from heavy-duty highway diesel trucks US\$ 2,700/tonne for NO_x and US\$ 17,000/tonne for PM is needed (IMO, 2009b). It means that the reduction of NO_x and PM emissions in shipping is relatively cheaper than land based. Thereby, it ensures that the NO_x and PM reduction scheme under ECA is reasonable.

Surprisingly, the cost effectiveness of SO_x is lower than other emissions, though the amount of SO_x emission reduction is the largest ones. In contrary, PM_{2.5} behaves in the opposite pattern. It shows that the recent technology to reduce PM_{2.5} emissions has not yet performed well. Furthermore, there is no dedicated abatement technology to reduce PM_{2.5} emissions except using lower sulphur fuel. Moreover, the amended Annex VI has not yet determined the allowable limit of PM_{2.5} emissions from ships. Consequently, the development of PM_{2.5} reduction technologies is encouraged to protect human health. In the efforts to reduce PM_{2.5} emissions, ECA implementation will save 8,300 lives and over three million people will recover from respiratory symptoms annually in the US while the monetized health related benefit is estimated as much as US\$ 60 billion in the U.S. in 2020 (EPA, 2009b, p.6).

The ECA implementation requires NO_x, SO_x and PM emission reduction. However, this dissertation will focus on efforts to reduce SO_x emissions, considering the emissions of SO_x is the major issue of acidification since 1972 and SO_x emissions from ships was the largest pollutant which compared unfavourably with other types of transport in 2000. The efforts to reduce SO_x emissions from ships will be discussed in the following:

3.3. The Methods of SO_x Emission Reduction

Regulation 14 of Annex VI addresses the methods of SO_x emission reduction, namely the lower sulphur fuel, the exhaust gas cleaning systems and any other technological method. Three different methods of SO_x emission reduction are aimed to alleviate acidification from acid rain by setting a sulphur limit in the fuel and the total emissions of sulphur oxide from ships. The methods of SO_x emission reduction are explained as follows:

3.3.1. Low Sulphur Fuel Oil (LSFO)

The amended Annex VI has already determined the maximum sulphur content of any fuel oil used onboard both outside and within ECA. The current global sulphur cap must not exceed 4.50%, and progressively it will be reduced to 0.50% in 2020. The current SECA allows 1.50% sulphur content in the fuel, which will drastically be reduced to 0.10% in 2015. The downward trend of sulphur fuel in Figure 3.4 shows the global sulphur cap will be set forth almost the same as the sulphur limit within ECA in 2020. In 2020, the global sulphur cap and sulphur content in the fuel within ECA will be allowed to 0.50% and 0.10% respectively. Fourteen years' duration (from 1996 to 2020) provides adequate preparation time for shipping industries, oil refinery industries and other parties to comply with the more stringent requirements on global sulphur reduction in 2020. However, this target will be reviewed considering the availability of distillate fuel oil (0.50% sulphur content) in the market. A review of standard must be completed by 2018 and must take into account: the global market supply and demand for fuel oil, an analysis of the trends in fuel oil markets and any other relevant issue (IMO, 2008d).

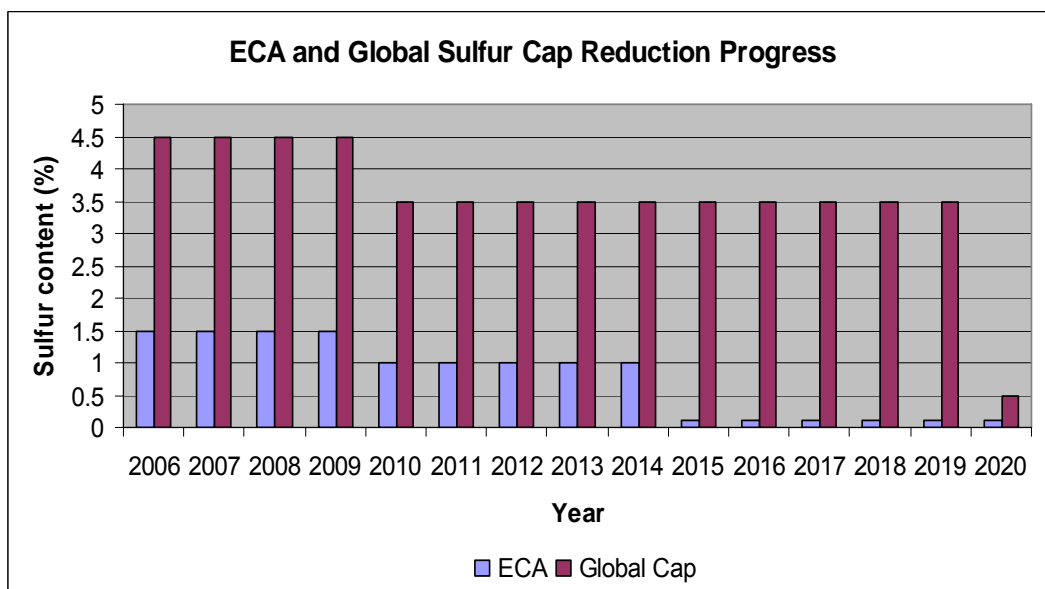

Figure 3-4. ECA and global sulphur cap reduction progress from 2006 to 2020

Source: International Maritime Organization. (2008b, October 17). *Report of the Marine Environment Protection Committee on its fifty-eighth session. (MEPC 58/23/Add.1)*. London: Author.

In order to analyse the trends in the fuel oil markets, IMO carries out global sulphur monitoring of fuel annually to identify the level of sulphur content in fuel. The global average of sulphur content in fuel is calculated, based upon the number of fuel samples tested and not the actual quantity of the fuel oil bunkered. The IMO sulphur monitoring (IMO, 2004; IMO, 2005; IMO, 2006a; IMO, 2007a; IMO, 2008a; IMO, 2009a) can be seen in the figure 3.5 as follows:

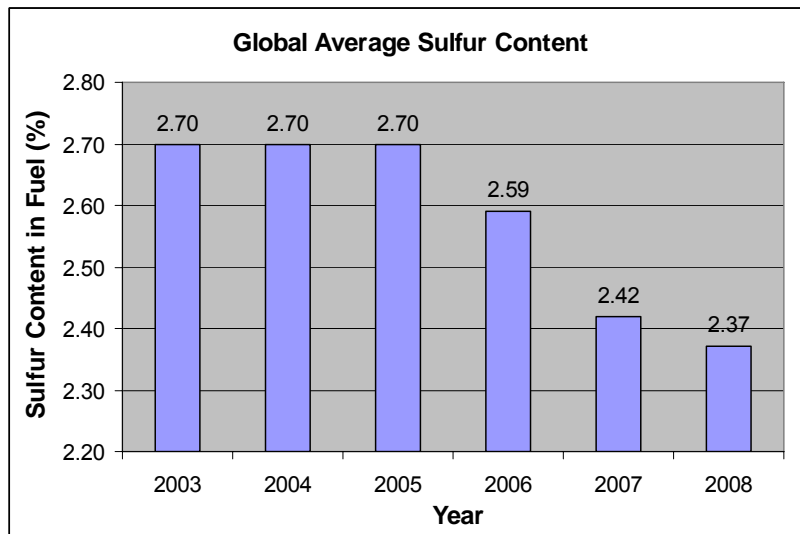

Figure 3-5. IMO sulphur monitoring program from 2003 to 2008

Source: various sources of IMO documents

The global average of sulphur content in the fuel remained constant at 2.70% until 2005. The next three years, the level of sulphur progressively decreased to 2.37% in 2008. The decrease in sulphur content level was triggered by the SECA and global sulphur cap scheme in 2006, so the demand of clean oil increased significantly. Consequently, the global average sulphur content in fuel can decline steeply in the forthcoming year because of the EU Directive 2005/33/EC regarding the use of 0.10% sulphur content in fuel at berth an inland waterway operations from 2010, the US and Canada ECA implementation in 2012, and the contribution of IMO decision on further reduction of the sulphur content in fuel oil until 2020.

The application of LSFO to reduce SO_x emissions is followed by supporting provisions under Annex VI to promote the compliance of regulations as follows:

3.3.1.1. Fuel Oil Availability

The amended regulation 18 of annex VI introduces the provision regarding the appropriate actions that should be taken by parties if ships are unable to comply with the standard of LSFO because of lack of fuel availability which is out of their control. The regulation prevents ships from being penalized by the competent party for non compliance fuel. Consequently, ship operators must notify both their Flag Administration and the competent authority of the port regarding non compliant fuel and present the records that prove the best efforts to acquire compliant fuel oil from the intended sources or other alternative sources.

This provision accommodates ships operating both outside and inside the Baltic Sea and the North Sea SECA. In particular, they may find difficulties to get such fuel oil in the ports outside SECA. The advantage of this provision enables ships voyage on their intended route to avoid delay. Ships navigating mainly within the Baltic Sea and the North Sea SECA may not encounter such problem in 2010 because of the sufficient availability of compliant fuel within the Baltic Sea and the North Sea. The problem can be experienced by ships operating within SECA when the use of 0.10% sulphur content in fuel will be introduced in 2015. This is possible because there is considerable scepticism about the availability such fuel oil.

3.3.1.2. Fuel Oil Quality

The regulation 18 of Annex VI also covers the fuel oil quality from petroleum refining and methods other than refinery products. In general, fuel must be free from inorganic acid, must not contain added substances which jeopardize the safety of ships or adversely affects the performance of the machinery or is harmful to personnel or contribute to additional air pollution.

In the same spirit, marine fuel oils must be supplied with Bunker Delivery Notes (BDN) and comply with requirements as per Appendix 5 of Annex VI. BDN is provided by fuel oil suppliers registered with the appropriate authority in the country where they operate. In this regards, the essential information of BDN is the sulphur content of actual fuel which must comply with regulation 14. The BDN must be kept

on board for PSC inspection and retained for a period of three years after the date of fuel delivery. The bulky ECA documents, which are presented in Appendix G, will increase the work load of PSC officers in performing inspection onboard ships.

The BDN must be accompanied by a statutory sample of the fuel oil delivered with reference to IMO guideline. MEPC 96(47) requires a sample quantity of at least 400 ml in volume that must be retained onboard for 12 months or until the complete bunker quantity is consumed, whichever is the longest period. The sample is taken from vessel's inlet bunker manifold, sealed and signed on behalf of the supplier and the Master or ship's officer in charge of the bunkering operation. Although fuel test takes time, upon request at PSC of contracting parties, it must be available for analysis according to verification procedures as stated in Appendix 6 of Annex VI.

3.3.1.3. The annual costs of LSFO and tank modification costs

Ritchie, de Jonge, Hugi and Cooper (2005, pp.19-20) estimated that the annual costs of LSFO for small, medium and large vessels, both new building ships and existing ships were the same in 2000 (Table 3.2.). It was calculated without capital expenditure because no additional systems and tanks were needed. This assumption can be applicable to ships trading exclusively within ECA which consume 1.50% sulphur fuel only. Therefore only operational costs are available annually.

Table 3-2. Annual cost of fuel switching for different size of ships

Methods	Vessel Condition	Vessel Size		
		Small	Medium	Large
Annual cost (euro/yr) to switch fuel from 2.70% to 1.50%	Existing / New building	156,907	513,694	1,282,237
Annual cost (euro/yr) to switch fuel from 2.70% to 0.50%	Existing / New building	201,737	660,464	1,648,590

Source: Ritchie, A., de Jonge, E., Hugi, C., Cooper, D. (2005). *Ship Emissions: Assignment, Abatement and Market-based Instruments*. Cheshire, UK: The European Commission, DG Environment.

The price of 1.50% sulphur fuel and 0.50% sulphur fuel in 2000 were 50 euro/ton and 64 euro/ton respectively and the fuel oil consumption approximately 200 g/kWh. Currently, the price of LS380 (fuel oil less than 1.50% sulphur content) is around US\$ 393/tonne (271 euro/tonne), while 0.50% sulphur fuel is approximately US\$ 497/tonne (343 euro/tonne) in July 2009 at Rotterdam Port (Bunker word, 2009).

Ships which are frequently navigating outside and within ECA may consume two grades of fuel (fuel oil at 1.50% sulphur content and fuel oil at maximum 4.50% sulphur content). This situation will force ship owners to add tanks and fuel handling systems of their existing ships. The capital costs of tank and fuel system modification are expected in the range of US\$ 50,000 to US\$ 100,000 for a typical cargo ships (Californian Environmental Protection Agency, 2007, p.55), while the costs of segregated tanks for Very Large Crude Carrier (VLCC) are estimated in the range from US\$ 200,000 to US\$ 300,000 (Tanker Operator, 2006, p.20). Ship owners who have limited budget can add bunker tanks only, while the number of settling and service tanks remains the same, although this system is very risky.

3.3.1.4. The benefit of LSFO

Since the residual oil is the root cause of most air pollution problems, switching it to clean fuel with the lower sulphur content can reduce most types of emissions. The clean fuel will lessen the demand of oil purifier. Thus, the amount of sludge in tanks and sludge burning in the incinerator will be minimized. Clean fuel in tanks can be heated easier because it has lower viscous characteristics than HFO, so the need of boilers and heating systems can be minimized. If the need of purifiers, boilers and heating systems can be minimized by consuming clean fuel, the capital and operational costs of ships can be reduced. For example, according to European Maritime Safety Agency (2005, p.52), the use of MDO in MS Turandot (one of Wallenius Lines' 37 vessels) reduced labour time for cleaning and maintenance of boilers and handling sludge on shore, and it saved money approximately US\$ 120,000/year.

The primary target of sulphur content limitation in fuel oil is to minimize the sulphur emissions as much as possible. In fact, fuel oil switching can also reduce PM at the

same time. The impact of LSFO on emission reduction was analyzed by Ritchie et al (2005) according to Table 3.3 as follows:

Table 3-3. SO₂ and PM emissions are caused by fuel switching

Methods	Emissions Reduction	
	SO ₂	PM
Switch of fuel from 2.70% to 1.50% S	-44%	-18%
Switch of fuel from 2.70% to 0.50% S	-81%	-20%

Source: Ritchie et al, 2005

The application of lower sulphur fuel has a meaningful affect on SO₂ and PM emission reduction. Use of 0.50% sulphur fuel oil causes SO₂ emission reduction almost twice from current standards (1.50%), while PM emissions will decrease by 2%. It is possible to extrapolate the emission reduction of using other sulphur content in the fuel from the information in Table 3.3. According to extrapolation results, lowering 0.10% sulphur content of fuel will reduce 3.7% of SO₂ emissions. If the reduction rate is applied for SO₂ emissions prediction in 2015, SO₂ emissions will decline by 95.8% when ECA requires 0.10% sulphur fuel. It can be understandable that the use of non-sulphur fuel oil can totally alleviate SO₂ emissions from ships. Consequently, the final benefit of SO_x emission reduction is decreasing effects of acid rain in order to improve the quality of the environment and human health.

3.3.2. Exhaust gas cleaning systems

The exhaust gas cleaning system is an alternative way to reduce SO_x emissions from main propulsion engines and auxiliary engines to 6.0 g SO_x/kW.h or less. It must be calculated as total weight of sulphur oxide emissions. At the moment, the scrubber is the only exhaust gas cleaning system available. It can be classified into seawater scrubber and freshwater scrubber. The development of scrubber technology has advanced considerably to meet the requirements of IMO guidelines for exhaust gas SO_x cleaning systems according to Resolution MEPC. 130(53).

3.3.2.1. Sea water scrubber

The seawater scrubber utilizes the slight alkaline salt water to absorb exhaust gases from engines. The water is filtered to separate particles for disposal into a settling tank, and then the water is re-circulated back into the sea (Figure 3.6). The scrubber efficiency is associated with the flow rate of sea water and the unlimited quantity of seawater is one advantage of such scrubber that may become a good choice.

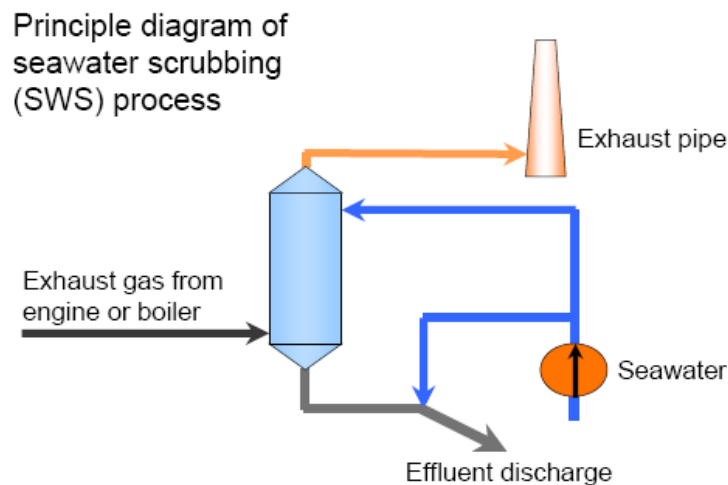

Figure 3-6. Principle diagram of seawater scrubbing (SWS) process

Source, Henriksson, T. (2006). The scrubber technology and SECA. *Service seminar presentation in Gothenburg*. Retrieved July 3, 2009 from the World Wide Web: http://www.wartsila.com/Wartsila/sweden/docs/locals/sweden/press/env_seminar_2006/scrubber_technology_seca.pdf

Unlike the fresh water scrubber, the seawater scrubber does not need additional chemical substances because the seawater has the adequate level of alkalinity and salinity. According to Andreasen and Mayer (2007, p.3274), the absorption capacity decreases with both decreasing salinity and alkalinity, especially in brackish water with close to zero salinity. Therefore, the effectiveness of seawater scrubber performance is influenced by the chemical composition of seawater where the scrubber is operated. The Baltic Sea is the largest brackish water in the world. It means that the alkalinity in the Baltic Sea is lower than normal alkalinity in other sea areas. Although the seawater scrubber can still operate normally, the efficiency of cleaning SO_x emissions is lower (Henriksson, 2007, p.57). Accordingly, the

application of seawater scrubber in the Baltic Sea SECA should be examined carefully with reference to the alkalinity and salinity level of the seawater.

Despite its low performance in brackish water, the seawater scrubber is very promising to reduce SO_x emissions as it compares favourably with low sulphur fuel. Several ships have installed the scrubber, such as MV. Pride of Kent. The scrubber can remove SO_x and PM emissions approximately 75% and 25% respectively with 2.50% sulphur fuel used onboard (Ritchie et al, 2005, p.iii). According to Ritchie et al (2005, p.ii), the lowest SO_x removal rate was around 65% because of limited sea water flow rates. Andreasen et al (2007, p.3274) found almost the same result about 66% within the Baltic Sea SECA. Consequently, seawater flow rates, alkalinity and salinity are the crucial factors in decreasing SO_x emissions by the seawater scrubber.

The annual seawater scrubber installation costs consist of the capital and operational costs. Ritchie et al (2005, p.17) estimated that the annual costs lie in the range of 50,000 – 338,000 euro/year for new building small, medium and large ships, while retrofitting costs for existing ship around 74,000 – 533,000 euro/year. Retrofitting costs is slightly larger than for new building ships. Accordingly, the application of the seawater scrubber in existing ships should consider the remaining life span of ships in order to analyze benefits versus costs during their service.

3.3.2.2. Fresh water scrubber

The fresh water scrubber uses additional chemicals to neutralize exhaust gas, such as caustic soda (NaOH). The principle mechanism of the freshwater scrubber is similar to the seawater scrubber, but the caustic soda is injected into the exhaust gas inside the system (Figure 3.7). According to Henriksson (2007, p.57), the cleaning efficiency is typically higher than 90% and depending on the lower sulphur fuel consumed by the engine. For example, use of 0.10% sulphur fuel will decline SO_x by 97%.

The freshwater scrubber is a good choice for ships operating in the Baltic Sea SECA, because this area has low salinity. Furthermore, the scrubber system can

periodically be operated without discharging wash water overboard. However, caustic soda, fresh water and wash water require adequate storages onboard. Therefore, existing ships may find difficulties to locate these materials in the limited space of ships.

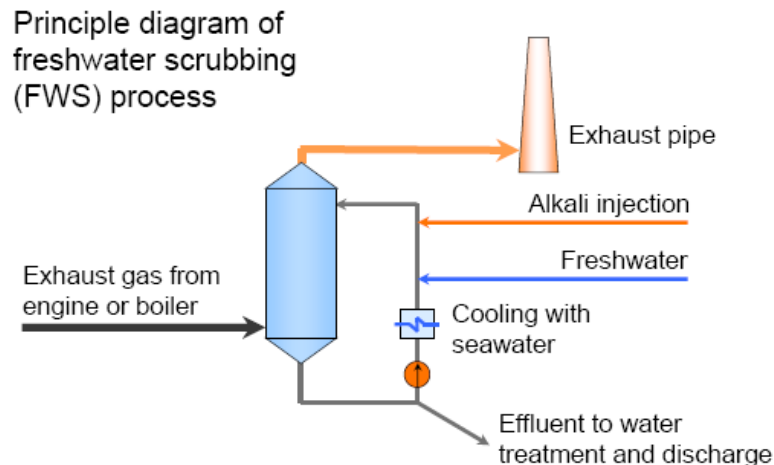

Figure 3-7. Principle diagram of freshwater scrubbing (FWS) process

Source, Henriksson, T. (2006).

3.3.2.3. The requirement of exhaust gas SO_x cleaning system onboard

The requirements of IMO guidelines for exhaust gas SO_x cleaning systems (EGCS) are stipulated in Resolution MEPC. 170(57). The guidelines permit two schemes of scrubber approval namely scheme A (Unit Certification with Parameter and Emission Checks) and Scheme B (Continuous Emission Monitoring with Parameter Checks).

In scheme A, the approval of the EGCS unit is conducted by the Administration within the manufacturing process together with EGCS Technical Manual (ETM). In order to ensure compliance of the scrubber with SECA requirements, the scrubber must have the SECA Compliance Plan containing how compliance is to be achieved, demonstrated and recorded and each item of fuel oil combustion equipment.

Prior to use within SECA, the Administration must issue the SECA Compliance Certificate (SCC) for ECGS unit for the compliant emissions limit of 6.0 g SO_x/kW.h as stated in EGCS Technical Manual. The initial, annual, intermediate and renewal survey of the ECGS unit should be carried out by the Administration and SCC should be endorsed at each survey. The ECGS unit together with the SCC and the ETM may also be subject to inspection by PSC officers.

In scheme B, the scrubber has to prove a ship's compliance by continuously monitoring emissions through exhaust gasses and water discharge. The compliance of emission monitoring must be approved by the Administration. The SCC is not required in scheme B, whereas the rest of the documents of scheme B are almost the same as in scheme A. It means that the development and improvement of scrubber efficiency will not be carried out in the type approval process again.

The scrubber and its associated equipment should have a dedicated record book to collect information about its operation and maintenance or alternatively this information can be recorded in Planned Maintenance Record Systems. In this regard, engineers should follow the procedure of operation and maintenance in an Onboard Monitoring Manual to meet the guideline requirements for operation and maintenance of the scrubbers.

The wash water discharge from scrubber operations is the main issue concerning its impact in the oceans. It is possible because wash water contains sulphur dioxide which can lower the average of pH of the oceans, which leads to ocean acidification. Hence, a guideline stipulates chemical substance and heavy metals in wash water should be reduced to a certain level. For example a pH of no less than 6.5 at the overboard discharge and PAH (Polycyclic Aromatic Hydrocarbons) should not be greater than 50 µg/L PAH_{phe} (phenanthrene equivalence) above the inlet water PAH concentration.

3.3.3. Other technological methods

The use of the boil-off gas with effectively zero sulphur content in conjunction with residual fuel oil (sulphur content above 1.50%) will be considered as the option

covered by regulation 14(4)(c) (American Bureau of Shipping [ABS], 2007). Regulation 14(4)(c) requires a limit of the SO_x emissions to a level equivalent to regulation 14(4)(b) (6.0 g SO_x/kW.h) and it must be approved by the Administration taking into account guidelines to be developed by IMO. However, the guidelines have not yet been developed by IMO.

With reference to regulation 14(4)(b), the dual fuel diesel engine (the boil-off gas and residual fuel oil) will possibly require the SECA Compliance Plan to ensure that the compliance of SO_x emissions can be achieved. In the absence of the guidelines, ship owners should approach the Administration to obtain approval of the dual fuel diesel engines. It is necessary to prove that this system complies with the desired requirements through calculations and then no engine emission testing is required (ABS, 2007).

3.4. Supporting policy to encourage SO_x emissions reduction

3.4.1. Fairway dues

A system of environmental differentiation of fairway dues is aimed to encourage ships to consume low sulphur fuel. The system is designed to give discount on the fairway dues to shipping companies based upon the sulphur content in the fuel oil used onboard. In November 2007, HELCOM issued HELCOM Recommendation 28E/13 regarding 3 options on economic incentives that may be implemented by contracting parties including differentiated fairway dues.

For example, in table 3.4 the Swedish Maritime Administration introduced the differential fairway charges in four levels of sulphur content in fuel oil, applicable to passenger ships and other vessels (Swedish Maritime Administration, 2004, p.4). Table 3.4 shows the sulphur related dues per unit of the vessel's gross tonnage. Reduced fairway dues will be granted to the ship owners who can prove and attest that ships consume low sulphur fuel. Consequently, ship owners should fill in a sulphur attestation form and provide BDN and statutory sample of fuel oil.

Table 3-4. The differentiated fairway dues in Swedish waters

Sulphur content percent by weight	Passenger Vessels (SEK)	Other Vessels (SEK)
0 - 0.2	0	0
0.21 – 0.5	0.30	0.20
0.51 – 1.0	0.60	0.40
1.01 -	0.60	0.60

Source: Swedish Maritime Administration. (2004, September 10). *Information concerning new fairway dues*. Retrieved July 3, 2009 from the World Wide Web: <http://www.sjofartsverket.se/upload/2205/New%20fairway%20duesEng.pdf>

The same treatment will also be given to ships with scrubbers, although recently there is no information regarding differentiated dues. Scrubbers should be surveyed by the Administration to ensure their compliance with regulation 14.4.(b). If the Administration is satisfied with the scrubber, a certificate will be endorsed as a basis to receive a fairway discount.

3.4.2. Port dues

About 20 Swedish ports introduced environmentally differentiated port dues by giving rebates to ships with lower sulphur fuel. The differentiated port dues are relevant to EU Directive 1999/32/EC and 2005/33EC because the enforcement area of regulations is EU ports. For example, port of Gothenburg takes extra charge of 0.20 SEK/GT for each call of passenger ships, ferries or rail ferries if the sulphur content of the fuel exceeds 0.50% and 0.10% for other vessels (Port of Göteborg, 2009, p.7). In 2010, the port dues for passenger ships, ferries and rail ferries may change since all ships must use 0.10% sulphur fuel oil when berthing in EU ports for a minimum of 2 hours.

The port of Mariehamn in the Åland Island also applies differentiated dues (Port of Mariehamn, 2009). Ships will be granted a 4% discount, if they use 0.50% sulphur in fuel. In another case, a discount of as much as 8% will be given to ships which consume 0.10% sulphur in fuel. Both ports employ sulphur content in fuel oil as a

basis to calculate port dues. While the port of Mariehamn gives discount, the port of Göteborg fines ships that exceed a certain limit of sulphur content in fuel.

The different approaches of port dues calculation, which are developed by the respective ports, are influenced by different motives. In the case of the port of Göteborg, the port dues calculation is based on a penalty approach which is driven by profit orientation. Undoubtedly, the enforcement of EU Directives will compel ship owner to consume low sulphur fuel within the port area. The target will be achieved, if all ships comply with intended requirements. Thus it is not to bring about negative effect on the Port of Gothenburg's revenue. In fact, its revenues will increase, if many ships violate the regulation. This method is relevant to business entity which mainly makes profit. Furthermore, the penalty approach in the form of extra port charges is additional punishment in addition to ship detention because of an infringement of the regulation. Consequently, it will strengthen the EU Directive implementation effectively in the ports.

In contrary, the port of Mariehamn encourages ships to use low sulphur fuel in the port by reducing the port dues. In the long term, it will diminish port's revenues since most ships can fulfil the EU Directives. Thereby, this approach is only suitable for voluntary regulations which motivate ship owners to involve it. Since the EU Directive is a mandatory regulation, ship owners make the best efforts to meet the regulation though without having financial advantage from port dues.

3.4.3. Emission Trading Scheme

Emission trading is the economic incentive mechanism that allows parties to buy and sell credits for emission standard in a defined area. The emission trading scheme enables shipping companies to comply with the environmental requirement in a cost effective way. In this scheme, financial incentive derived from trading will encourage emitters to comply with the emission regulation through purchase of LSFO or investment in an exhaust SO_x gas cleaning system (abatement technologies).

The emission trading scheme is carried out by shipping companies voluntarily, but it has not yet come into actual practice. Shipping Emission Abatement and Trading (SEaAT) is a pilot project of emission trading (using an offsetting mechanism) conducted by a group of ship owners with 45 vessels operating within or through the North Sea SECA (IMO, 2006b). Some of them consume 2.70% sulphur fuel and the rest uses 0.20% sulphur fuel or abatement technologies.

In figure 3.8, low emission ships can sell credit (1300 t) because the sulphur emissions (200 t) released from the ships is lower than required standard in SECA (1500 t), while ships visiting SECA will buy credit (1200 t) from low emission ships because sulphur emissions is emitted from ships (2700 t) exceeding required standard in SECA. Therefore, lower emissions from some ships will be used to offset the higher emissions from others, so the overall result should reach as low as 1.50% sulphur fuel.

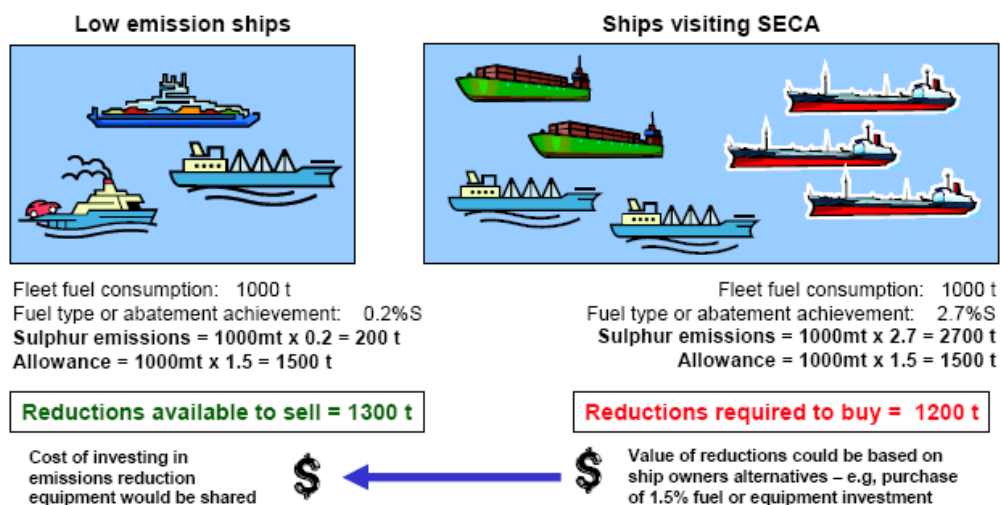

Figure 3-8. SO_x emission trading mechanism

Source: International Maritime Organization. (2006b). *Information on the potential of emissions trading to reduce harmful emissions into the air from ships: Submitted by the United Kingdom. (MEPC 55/INF.7)*. London: Author.

This mechanism enables low emission ships to share the costs of emission reduction technologies to SECA ships by selling credit, while the SECA ships will be encouraged to use lower sulphur emission or abatement technologies to avoid

buying expensive credits. The benefit of this mechanism is that ship owners have a strong economic incentive to comply with the emission regulation and make some profit from investing in emission reduction technology (Arvidsson, 2007, p.49). In fact, financial support is required to catch up with the emission requirements that need further technical measures.

The emission trading will effectively be implemented provided that the surveying and verifying mechanisms of emission reductions from ship are available. These are essential to ensure the validity of ship owners' claim regarding the quantity of emission reduction from their ships. The claim will be a basis for ship owners to sell or buy credits to other parties. In the few years, such mechanisms, which are powered by emission monitoring technology, are possible to be performed.

3.5. Conclusion

Recently, the global sulphur cap is 4.50% and SECA restricts the sulphur content in fuel oil to 1.50%. The current sulphur level of fuel oil is applied in the Baltic and the North Sea SECA. The performance of SECA in both seas is relatively promising concerning the less impact from ships operating exclusively within SECA and its future benefits. The scheme is followed by US and Canada through an ECA proposal submission in March 2009 to restrict SO_x, NO_x and PM within their EEZ, with the predicted advantages that will outweigh the disadvantages.

In 2020, both ECA and global sulphur content will be limited in fuel to 0.10% and 0.50% respectively. Perhaps ECA will not be required anymore since both regimes could restrict to the same level of sulphur fuel after 2020. Accordingly, the uniformity of the sulphur cap worldwide will diminish comparative disadvantage barriers in terms of economy among shipping operators. It will also lessen ship operation problems when carrying two qualities of fuel oil onboard and reduce significantly global sulphur oxide emissions from ships.

As discussed above, there are three methods to minimize sulphur oxide emissions, namely using low sulphur fuel, exhaust gas cleaning systems and any other technology with similar performance to exhaust gas cleaning systems. The above

mentioned methods are complemented by economic incentives through fairway and port dues and emission trading. They are useful to encourage and enforce ship owners to comply with the emission regulations.

Lowering the sulphur content in fuel oil will reduce SO_x and PM emissions, although it creates complex problems such as the availability of low sulphur fuel, the change over process and the incompatibility of lubrication oil. In the case of scrubbers, they will potentially be the best choice to reduce SO_x emissions significantly if they have been fully installed in most ships. However, the use of scrubbers replaces the air emission problems with marine pollution because washwater discharges from scrubber might create ocean acidification.

Unlike SO_x emissions, the allowable limit of PM emissions from ships and PM abatement technology has not yet been developed. It will influence the efforts to reduce PM emissions in order to protect human health. Furthermore, more stringent standard of NO_x emissions has not yet been determined by IMO for the next steps to be taken after tier III. Accordingly, IMO is expected to set forth the quantity of PM emissions (g/kW.h) and long term planning of NO_x emission reduction into its forthcoming regulations.

CHAPTER 4

THE EFFECTIVENESS OF SECA IMPLEMENTATION

A big question has arisen concerning the effectiveness of SECA implementation during the period of three years since 2006. Over three years, several improvements have been made by IMO through the amended Annex VI, in which the IMO unified the interpretation regarding sulphur limits in fuel, the requirement on wash water discharge according to IMO Guidelines for Exhaust Gas Cleaning Systems and other relevant IMO legal framework. These improvements are expected to ensure clean ship operations within SECA.

Effectiveness is related to measurement of output (Paladino, 2007) or the objective of a process. This definition makes it easier to identify the effectiveness of SECA implementation. In general, the objective of existing SECA is to reduce acidification in the Baltic Sea and the North Sea. Therefore, if the objective can not be achieved, the effectiveness of SECA implementation may be questionable. The emissions of SO₂ is expected to increase by more than 42% by 2020 (Figure 4.1) even after the enforcement of MARPOL Annex VI, especially SECA in the Baltic Sea, the North Sea and the English Channel, while pollutant from land based sources are gradually going down (The EEB et al, 2004).

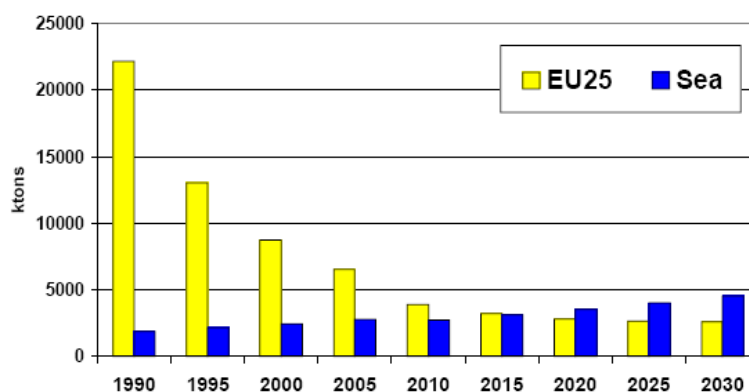

Figure 4-1. Emissions of SO₂ from 1990 to 2010

Source: Amann, M., Bertrok, I., Cofala, J., Gyarfas, F., Heyes, C., Klimont, Z., Schöpp, W., Winiwarter, W. (2004) *Baseline scenarios for the Clean Air For Europe (CAFE) Programme. Report Contract B4- 3040/2002/340248/MAR/C1*. Brussel: The European Commission, DG Environment.

From Figure 4.1, it is indicated that the SECA regime has not yet been effective enough to reduce SO₂ emissions from ships, which leads to the increase in acidification. Although the SO₂ emissions increase gradually by 2020, SECA may decelerate the increase rate of SO₂ emissions. Otherwise, there will be a considerable increase in SO₂ with more than 42% in 2020. However, people tend to ignore it since the final output shows SO₂ emissions remain increasing.

4.1. Ishikawa diagram of SECA problems

The non effectiveness of the SECA implementation is influenced by many factors. These factors contain problems which should be overcome to improve SECA effectiveness. Problems surrounding SECA can be identified systematically by means of the Ishikawa diagram. The Ishikawa diagram is a management technique, useful in decision making which is descriptive rather than quantitative (Hannagan, 2007). It shows causes and their relationship with a set of factors, for example people, material, environment, machinery and methods. The set of factors depend upon problems that would be resolved.

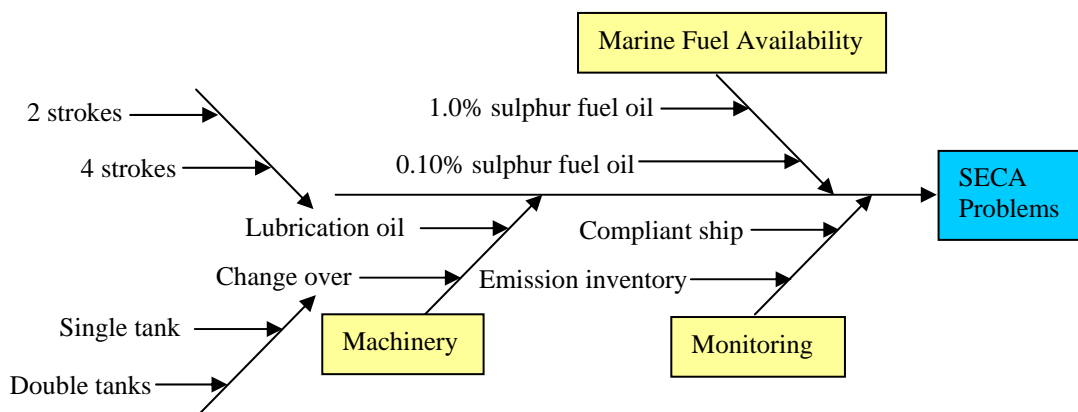

Figure 4-2. The Ishikawa diagram of SECA problems

Source: Author, 2009

As can be seen in figure 4.2, the set of factors are marine fuel availability, machinery and measurement technology in the case of SECA implementation. Certainly, there are many factors rather than only these three factors which cause the non effectiveness of SECA. Other factors are possible to be included provided they are relevant. In this case, three factors are derived from facts and discussions in previous chapters. Most factors are associated with technical and operational issues.

The first factor is marine fuel oil, which is the essential factor that contributes to the SECA regime. The current regulation related to sulphur content restriction in fuel oil has caused the uncertainty of marine fuel availability with sulphur content of 1.00% and 0.10%. The second factor is machinery. It is complicated to operate main engines with different grades of fuel onboard ships with single and double fuel tanks and to select suitable lubrication oil for two and four stroke engines. If the difficulties can be managed, SO_x emissions from ships can be maintained as low as the SECA requirements. The third factor is monitoring of compliant ship. PSC officers rely heavily on bulky documentation to inspect the compliance of ships against the SECA regulation. Furthermore, if the fuel oil sample is tested, the analysis takes time, which will delay the ship departure. Another problem is the uncertainty of SO_x emission inventory, which will mislead policy makers to formulate appropriate measures regarding SO_x emission reduction.

4.2. Marine fuel availability

4.2.1. The availability of 1.00% sulphur fuel oil

The availability of shipping fuel in the market is a critical factor to determine the target of sulphur content reduction in fuel oil. There might still be uncertainty about sufficient supply of fuel oil to meet the ambitious target of IMO in lowering the sulphur content in fuel oil progressively by 2020. In this regards, the amended Annex VI will entry into force in 2010, which requires sulphur content in fuel oil of 1.00% and 3.00% within and outside SECA.

Within the existing SECA, the availability of 1.00% sulphur fuel oil will be sufficient because the demand of such fuel will not involve major investment of refining capacity. The fuel consumption within existing SECA was estimated only about 8% of the global fuel consumption (IMO, 2009c), and therefore, the current refining capacity can manage the demand. Furthermore, the US and Canadian ECA will not be enforced until 2010, so most distillate oil demand will be concentrated to the Baltic and the North Sea SECA. In fact, Linda K. Wright, Global Director at Exxon Mobil Marine Fuels, ensured that the IMO target for lowering to 1.00% sulphur content in fuel within SECA will be achievable (Einemo, 2008, p.7). Although supply

of sufficient 1.00% sulphur fuel oil would become challenging when more SECAs are declared, the required fuel stock in the coming US and Canadian ECA is available (Chapter 3).

4.2.2. The availability of 0.10% sulphur fuel oil

The major problem with fuel supply will be encountered at the next stage of the IMO target. The International Petroleum Industry Environmental Conservation Association (IPIECA) argues that the supply of distillate oil at 0.10% will not be available at the expected date of 2015 in all regions (IMO, 2008b, p.10). It is not a problem provided that there is adequate distillate fuel oil available within existing and forthcoming SECA, where ships will be obliged to consume 0.10% sulphur fuel. If these areas suffer fuel supply uncertainty, the IMO target may not be executed within the desired time frame.

The US and Canadian EEZ was designated as ECA in the MEPC 59th session in July 2009. According to the ECA proposal, the supply of distillate oil at 0.10% in US and Canadian ECA is predicted sufficient in 2020. Based upon WORLD (World Oil Refining Logistic and Demand) model, the ECA will need less than 16 million tonnes which corresponds to 3% of the global consumption (IMO, 2009b). It is not surprising, since US enjoys a surplus of distillate oil and therefore they can export distillate oil to other regions.

The EU Directive 2005/33EC prohibits suppliers in the EU ports the sell of > 0.10% sulphur fuel. Therefore it implies that 0.10% sulphur fuel is available within EU waters including existing SECA from 2010. Nevertheless, it does not mean that such fuel is adequate to supply ships within SECA from 2015. The Baltic and the North Sea SECA will face a tough situation to satisfy the distillate oil demand. There is an early warning sign of distillate oil shortfall. Europe is already short of diesel oil (0.50 % sulphur fuel) and has to import it from the US (Distilling the Argument, 2007, p.14). In this case, the main problem with fuel availability is the limited refining capacity. In the near future, the stock of distillate oil at 0.10% sulphur content may not be sufficient for all ships within the Baltic and the North Sea SECA in 2015. Furthermore, marine transport will compete with road transport and other sectors

using distillate fuels. Accordingly, the shortfall of distillate oil in Europe should be overcome by importing distillate fuels from outside Europe or increasing the oil refining capacity within Europe.

Import distillate oil is only a temporary measure on the supply and demand balance. The US is still the best option for importing distillate oil, but the increasing demand in the US domestic market both for sea and land based consumers will force the US to keep its distillate oil production. If there are no more choices than using distillate fuel, thus a significant refinery investment is needed to meet the growing demand for distillate oil.

4.2.3. The complexity of incremental refining capacity

In recent years, the parties concerned have concentrated on the availability of 0.50% sulphur fuel in 2020 through investment analysis. Most discussions reveal the incremental refinery capacities involving huge investment costs and environmental impacts ([Air Emission, 2008a], [Distilling the Argument, 2007]). Several scenarios have been proposed to oil refining industries but none of the proposals provide a simple solution.

New refinery unit construction will need at least 5 years taking into account planning, the processing site preparation, site design and environmental assessment. To meet the huge demand of distillate fuel (Table 4.1), the incremental refining capacities will need to invest US\$ 318 billion to replace the 382 million tonnes of HFO with distillate fuel in 2020 at 0.50% sulphur fuel and it will increase 11% or 133 million tonnes of additional of CO₂ emissions (Air Emission, 2008, pp. 9-10). Switching of more than 300 million tonnes of HFO to distillate fuel means an increase in global oil production, which threatens the demand of other oil consumers. Furthermore, the energy required to remove sulphur from the fuel in order to protect the environment may increase the amount of CO₂ emissions to the detriment of the global environment.

Table 4-1. The estimation of HFO and distillate fuel in 2007 and 2020

Calculation assessment	Result 2007 (Million tonnes)	Result 2020 (Million tonnes)
Total fuel consumption by ships	369	486
Total HFO consumption by ships	286	382
Total distillate consumption by ships	83	104

Source: Air emissions from ship – time is running out. (2008a). *BIMCO Bulletin*, 103 (1), 8-12.

The desulphurization of HFO through refining processes is likely to be very costly. Therefore the refining industries would not be prepared to commit huge investment to build new refinery installations in consideration of the profitability in the short time frame, the sustainability of distillate fuel price, the uncertainty in the volatile market and the penalty because production of more CO₂ emissions.

The aforementioned analysis has drawn the attention to the fact that the introduction of global sulphur cap to 0.50% sulphur fuel oil in 2020 entails complex problems. It can be understandable that the oil refining industries will experience a tough situation in the next few years since the use of 0.10% sulphur fuel oil will enter into force in 2015 within ECA, although it may occur with less intensity. Relying heavily on the oil refinery industries should be avoided. Otherwise, IMO target will not be achievable.

4.2.4. What can be done

IMO member states and oil refining industries are strategic partners in discussing the level of the sulphur cap and the right time frame. In this partnership, IMO can not enforce the oil refining industries to meet the IMO target. The oil refining industries will consider commercial aspects for their business that will convert crude oil into profitable oil products. Accordingly, it is a challenge for IMO to secure its plan on track in order to reduce SO_x emissions for cleaner ship operations.

There is a tendency that the agreed measure of lowering sulphur content in fuel oil may be influenced by intense environmental pressures rather than the technical and scientific feasibility. It is possible because the WORLD model demonstrated that

wholesale switch to distillate fuels is not realistic for 15 or more years (Air emissions, 2008a, p.10). It means that changing all residual fuel to distillate fuel is impossible. There are two options to overcome such a problem, either reschedule the IMO target or boost alternative methods in order to lessen the burden of refining industries.

4.2.4.1. Scrubbers: the most feasible alternative method

The IMO regulation enables a ship to be equipped with scrubbers and use residual fuel oil (4.50% sulphur content), provided that SO_x emissions released from the ship are not more than 6.0 g SO_x/kW.h. Undoubtedly, shipowners prefer scrubbers because the lower price of residual fuel compares favourably with the distillates fuel oil. The cheapest price of HFO is an advantage for ship operations to lower fuel costs instead of doubling fuel costs if the engines consume distilled products, such as MGO. Furthermore, the seawater scrubber is a more cost effective measure than the distillate fuel oil (Table 4.2). The costs of scrubber installation and operations is relatively lower than low sulphur fuel oil, both for new building ships and retrofitting existing systems. Thus the ships with scrubbers will demand a considerable amount of residual fuel.

Table 4-2.Costs effectiveness of SO₂ reduction measures comparison between seawater scrubbers and fuel switching

Measure	Ship Type	Small	Medium	Large
		(euro/tonne fuel)		
SW scrubber	New	16	14	13
	Retrofit	24	22	21
Fuel switching: 2.70% S fuel to 1.50% S fuel	New Retrofit	50	50	50
Fuel switching: 2.70% S fuel to 0.50% S fuel	New Retrofit	64	64	64

Source: Ritchie, A., de Jonge, E., Hugi, C., Cooper, D. (2005). *Ship Emissions: Assignment, Abatement and Market-based Instruments*. Cheshire, UK: The European Commission, DG Environment.

The estimation of the refining capacity does not take into account the considerable amount of residual fuel that will be used by ships with scrubbers. The investment

costs of the refining capacity will decrease significantly when considering the huge demand of residual fuel used by ships with scrubbers. In this case, the oil refinery converts either crude oil or residual oil to get a certain amount of distillate fuel oil, and the remaining residual fuel oil will be consumed by ships with the scrubbers. Therefore, IMO should estimate the fuel demand from ships with the scrubbers, and that information can be used by oil refining industries to anticipate forthcoming distillate oil production. This scenario will be expected to ensure profitability in the short time frame and to lessen investment costs and CO₂ emissions. Consequently, the use of scrubber onboard ships will offset the incremental demand of distillate fuel within 2015-2020 and cost increases over coming decades.

4.2.4.2. The Problems and Opportunities of Scrubbers

Shipowners still doubt the viability of scrubber technology, although some manufacturers have received a product design type approval under scheme A and approval for exhaust and water outlet monitoring under scheme B from classification societies for their scrubber systems. Some uncertainty relates to the requirement of washwater discharge according to IMO Guidelines for Exhaust Gas Cleaning Systems (resolution MEPC.170(57)) whether it can be complied with, when the scrubbers are used continuously and whether it can be accepted by port state control officers. Furthermore, there is no single solution to reduce all emissions. Consequently, shipowners should install both NO_x and SO_x abatement technologies onboard, which will incur more financial burden.

The only one reason that will trigger shipowners to fix scrubbers is when the price of distillate fuel oil is not anymore economically attractive. Meech (2009) predicts that the costs difference between a 1.50% sulphur bunker and 1.00% sulphur bunker fuel in 2010 will be about \$55 per metric tonne (pmt). In 2015, however, the costs difference between a 1.00% bunker fuel and 0.10% would be about \$300 pmt. Thus, the price of distillate fuel oil will be higher in 2015 than 2010. With respect to incremental bunker costs, the shipowners do not have many choices and the scrubber will be the more feasible option. In the next five years, the advance technology of scrubbers is expected to address the aforementioned problems, which will convince the shipowners in terms of technical feasibility.

4.2.4.3. Liquefied Natural Gas (LNG): fuel of the future

Several alternative energy sources to propel ships are proposed, such as bio-fuel, solar cells and LPG but the energy sources need to be readily available worldwide. Consequently, these aforesaid energy sources will not be attractive in price. In the next few years, the LNG onboard ships are expected to be the common marine fuel. Currently, there are 52 oceangoing ships operating or on order worldwide fuelled by LNG (Brukner-Menchelli, 2009) to gas turbines, gas engines and dual fuel diesel electric engines. Several reasons drive the rapid development of LNG as marine fuel including the cheaper price of LNG, the huge deposit of LNG resources worldwide, the increased awareness of environmental care and the progressive tightening of emission controls.

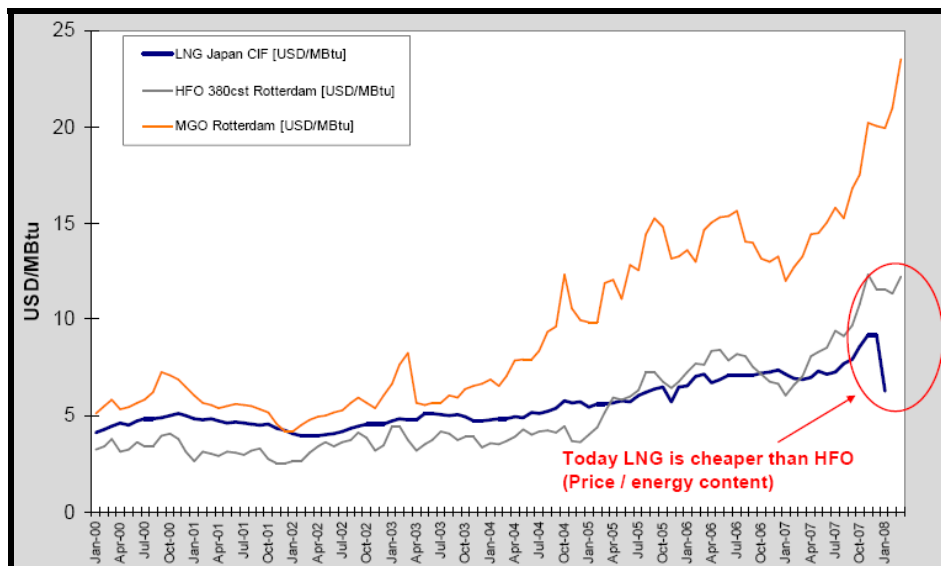

Figure 4-3. The price comparison among MGO, HFO and LNG

Source: Levander, O. (2008). *Reducing local emissions by switching to LNG*. Paper presented at Motorship propulsion & emissions conference 2008, Gothenburg, Sweden

LNG looks attractive for the long term since it is the largest energy source that will last about 130 years, and also the cheaper one. The LNG price has been cheaper than MGO and especially HFO since 2005 (Figure 4.3). It is predicted to remain relatively stable and competitive, while the cost of MGO increases dramatically because of the more stringent emission control within SECA from 2015. It can be

understandable that the excessive MGO price in the future will push more and more shipowners to order ships using LNG fuel.

The combustion process of LNG in engines is very clean compared with oil based fuel. Running on LNG will eliminate SO_x emissions because no sulphur is present when natural gas is liquefied. In practice, the derivative emissions of SO_x, namely PM will be close to zero. Furthermore, compared with MDO, using LNG will reduce CO₂ and NO_x about 26% and 80%-90% respectively (Einang, 2009). Hence, LNG is a double solution for more environmentally benign sound and more attractive with future oil prices.

In the coming years, the number of ships with LNG fuel will grow in the Baltic and the North Sea SECA. The trend is driven by Norway, which plays a leading role in the development of LNG ship operations. A considerable number of coastal ferries navigate within Norwegian waters, supply boats operate in the North Sea offshore terminals, and the use of dual fuel LNG carriers on projected trades into the Baltic for Russian export of gas cargos and North Sea destinations (ABS, 2007, p.40) are several examples of short sea shipping trade that will gain benefits of LNG.

The short sea shipping trade within the Baltic and the North Sea SECA is more economically viable because the availability of LNG and the distribution infrastructures. In fact, the number of LNG terminals is already available around the Baltic Sea and within Europe. Therefore, they sufficiently cater shipping movement throughout Northern Europe and down to the Mediterranean (Air emissions, 2008b). Since Europe is already unable to supply adequate quantity of distillate fuel, the growing use of LNG as fuel brings a positive sign to ensure a stringent emission control within the Baltic and the North Sea SECA to be managed in 2015.

The main problem of marine fuel based upon LNG is the need of sufficient space for the LNG storage. At the same energy content, LNG has a volume 1.8 larger than diesel oil; therefore vacuum isolated pressure storage LNG tanks have been adopted as a solution (Einang, 2007). In practice, existing ships may get difficulties to find the desired space to retrofit their systems to employ LNG fuel. In the

newbuildings, the considerable storage will affect the tank arrangement in double bottom tanks and the area of engine space. Consequently, the entire ship arrangement will influence the ship dimensions and the cargo/passenger ship capacity.

4.3. Machinery: Fuel system arrangements to comply with SECA requirement

The MARPOL 73/78 Annex VI stipulates the global limit for sulphur content of marine bunkers to 4.50% and 1.50% within SECA. It has not great operational impact on ships operating exclusively either within SECA or outside SECA. The complication arises for ships which use different grades of fuel oil when navigating in both areas. In that case, it is beneficial to segregate bunkers, settling and service tanks to simplify change over from high sulphur fuel oil (HSFO) to LSFO prior to entry into SECA. This recommendation is easily adopted by newbuildings, but existing ships have several options to meet the compliant of sulphur fuel oil within the SECA. However, ships navigating within and outside SECA should carry three different grades of fuel oil because EU Directive 2005/33/EC imposes 0.10% sulphur in fuel on ships at berth in UE ports at least 2 hours from 2010. Otherwise both ships and ports are equipped with shore-side electrical power to replace the use of 0.10% sulphur in fuel in order to generate electricity.

4.3.1. Existing ships with single tanks for two grades of fuel oil

Shipowners may preserve single settling and service tanks (Figure 4.4) without retrofitting because of the retrofit costs and limited spaces onboard for additional tanks. In this case, the blending process is commenced in the settling tank and afterwards in the service tanks and connected piping. Consequently, the change over duration will be longer and relatively complex.

The dilution will take more time depending on the sulphur content in the two fuel oils, the fuel oil consumption rate and the blending volume. According to Wäertsillä (2006), several days are needed to reach the new sulphur level before entering into a SECA as well as upon exit from a SECA.

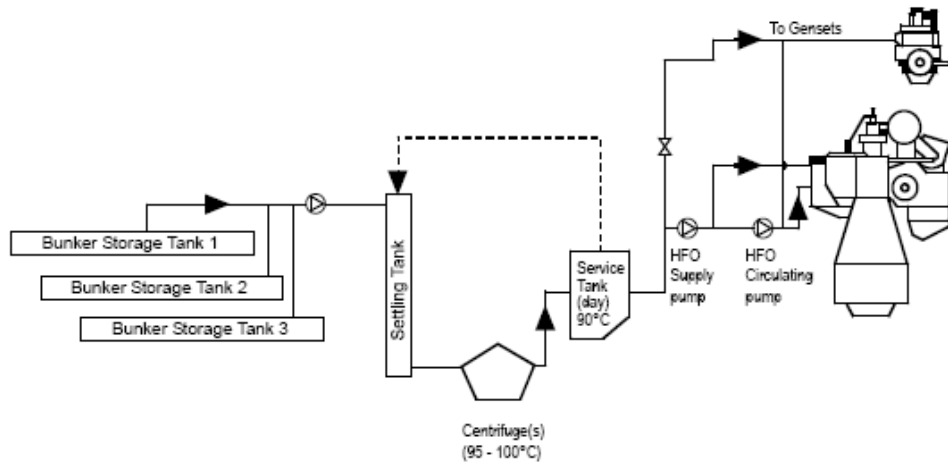

Figure 4-4. Fuel system with single settling and service tanks

Source: CE Delft, Germanischer Lloyd, MARINTEK, Det Norske Veritas. (2006). *Greenhouse gas emissions for hipping and implementation guidance for the marine fuel sulphur directive (Rep. No. 06.4103.61)*. Delft, The Netherland: CE Delft.

As is shown in Figure 4.5, sulphur content at 1.40% in fuel oil can be reached in 160 hours (around 6 days) before entering a SECA. A ship leaving a SECA needs 140 hours (more than 5 days) to increase the sulphur content in fuel oil to 2.90%. The duration of change over can be minimized by reducing content of settling and service tanks but Det Norske Veritas [DNV] (2006) recommends that the service tank should contain enough fuel to maintain continuous rating at the propulsion plant.

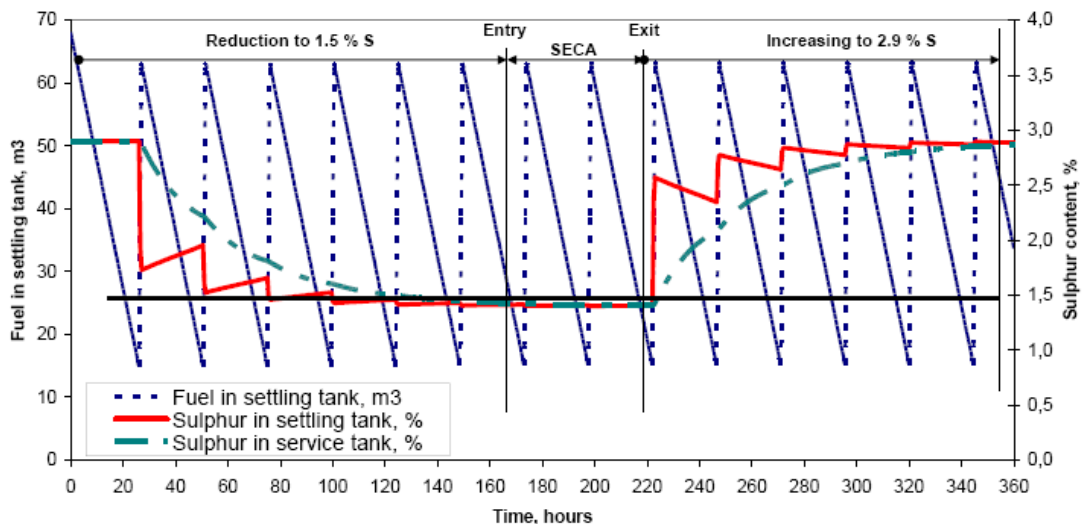

Figure 4-5. Fuel sulphur content vs time when alternating between 2.90 % and 1.40 % sulphur.

Source: Wärtsillä. (2006). *Low sulphur guidelines*. Helsinki: Author.

The main problem of mixing different fuel oils during the change over process is the risk of fuel incompatibility. The fuel incompatibility causes operational problems such as fuel coagulation, sticking of fuel injection pump, clogging of fuel filters and separators that will increase the risk of stopping engines unintentionally. Fuel compatibility problems are related to fuel stability reserve. HSFO is rather aromatic and does contain asphaltenes. Thus, if the stability reserve of the heavy fuel oil is low, it cannot tolerate the mixing of more paraffinic distillate fuel since this will cause asphaltenes to precipitate out of the blend as sludge (Marshall, Rynn, Stanton, Horn, 2007).

The fuel incompatibility can be avoided by conducting a compatibility test with a kit on board before blending the fuels. The test can also be done by an independent laboratory, but it takes time and therefore the ship will already have left the port before the test result returns. In this case, the change over process should be performed by experienced engine crews and supported by well-defined change over procedures and engine manufacturer recommendations. Accordingly, the option of segregated tanks is highly recommended to ships with more frequent visits in SECA.

The inspection of SECA compliance is performed onboard by PSC when ships enter the port. The engine log book should be checked carefully by PSC, especially information about the change over process. There is a possibility to make up information in the log book to deceive PSC officers. The non-experienced PSC officers may find difficulties in checking the dilution time prior to entering the SECA border because there is no standard of change over, and different engines have different characteristic operations. Therefore, the PSC officer is expected to calculate the dilution time independently in case of suspicious information in the log book. Therefore, it is possible that the Administration or Classification Society approves the change over manual, so that the change over procedure is suitable for each engine.

4.3.2. Existing ships with segregated tanks for two grades of fuel oil

Existing ships should be retrofitted and install additional tanks (bunker, settling and service tanks) during docking prior to their service in SECA. Furthermore, the use of

0.10% sulphur fuel at berth according to the EU Directive can be managed by allocating such fuel in a dedicated tank. In practice, additional tanks and fuel systems would simplify switch over operation prior to entering a SECA and bunker management in the ports. The possible arrangement for additional fuel oil tanks to accommodate two different types of fuel (4.50% and 1.50%) is depicted in Figure 4.6. The same tank arrangement can be built for MGO (sulphur content to 0.10% in the fuel).

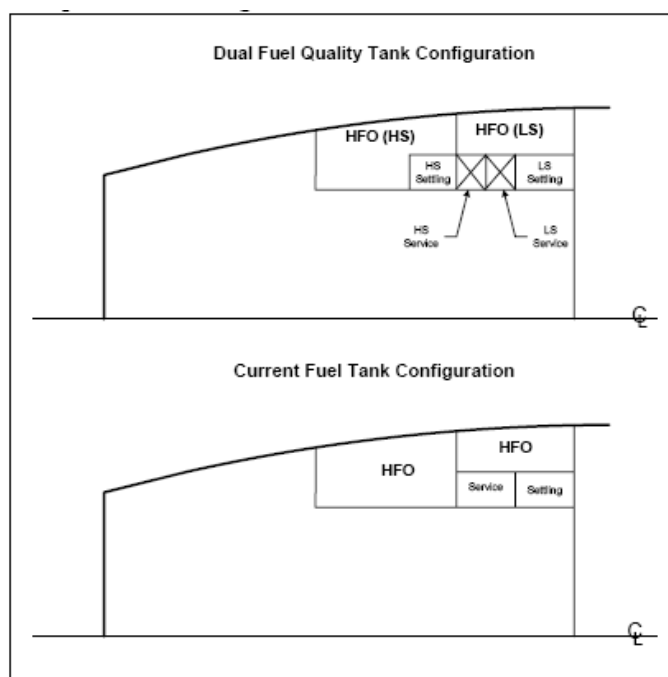

Figure 4-6. Example of tank modification

Source: Marshall, G., Rynn, P.G., Stanton, M.E., & Horn, G.E. (2007). Tanker safety-regulatory change. *WMU Journal*, 7 (1), pp. 317-351.

Marshall and his colleague's work on tank modification is relatively simple by adding a high sulphur (HS) tank and dividing a low sulphur (LS) tank. Nevertheless, their work does not consider the demand of LSFO and HSFO when ships enter and leave into a SECA to determine the capacity of each tank. A priority should be given to the capacity of the LSFO tank since the adequate quantities of LSFO within SECA must be entered in a log book. Otherwise, the lack of LSFO will force the ships to use HSFO within the SECA, which violates regulation 14 of Annex VI. Although the capacity of the LSFO tank is sufficient, the supplier may not fully provide ship

demand on LSFO. In this case, ship officers are obliged to present the necessary records of the aforementioned situation as per regulation 18.

The change over process from one to another fuel oil always is followed by a blending process. In figure 4.7, the blending takes place in the piping between the service tanks and the inlet to the engine. Since the tanks are completely separate, the change over is a relatively simple and quick operation. At the end of the change over time, the level of sulphur content in the fuel oil is expected to reach as low as 1.50%.

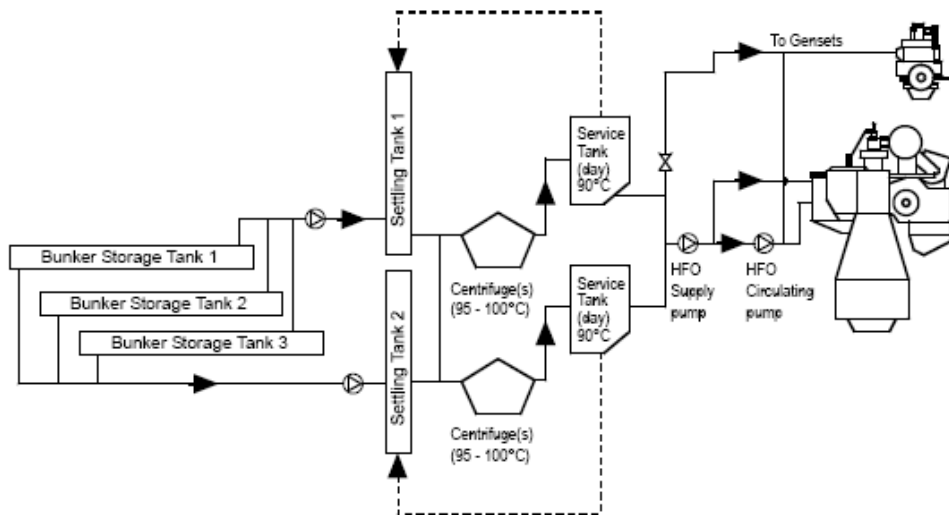

Figure 4-7. Fuel system with double settling and service tanks

Source: CE Delft, Germanischer Lloyd, MARINTEK, Det Norske Veritas. (2006). *Greenhouse gas emissions for shipping and implementation guidance for the marine fuel sulphur directive (Rep. No. 06.4103.61)*. Delft, The Netherland: CE Delft.

The regulation 14 (6) of Annex VI requires sufficient time for the fuel oil systems to be fully flushed of all fuels exceeding 1.50% prior to entry into SECA. DNV (2006) provides simple graph to calculate dilution time as stipulated in regulation 14 (6). The graph is depicted in figure 4.6. For example, the blending process in the piping needs 20 minutes to change over from 3.10% HSFO to 1.30% LSFO, the dilution time is estimated = 260% x 20 minutes = 52 minutes prior to entry into SECA. The rate of 260% is obtained from the figure 4.8.

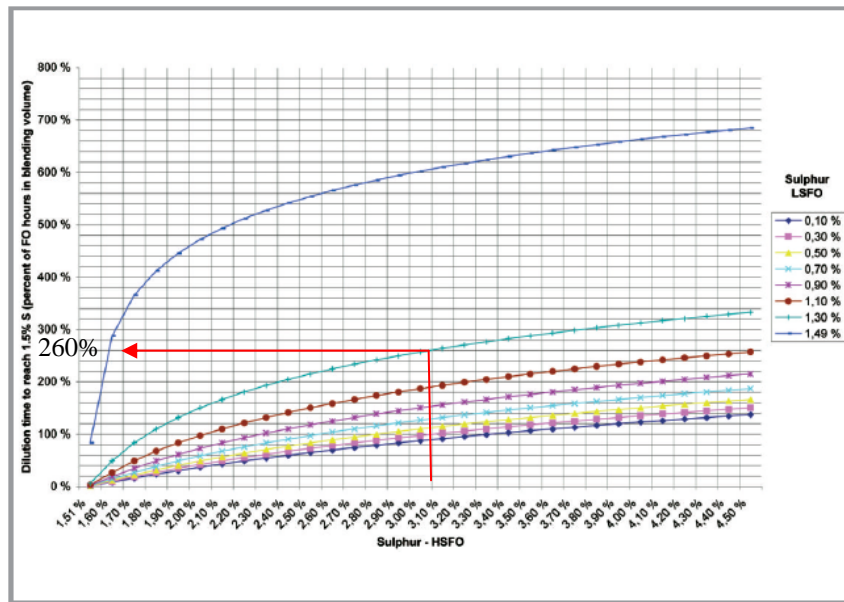

Figure 4-8. Dilution time to reach 1.50% S in percent of the fuel oil hours contained in the blending volume

Source: Det Norske Veritas. (2006). *MARPOL Annex VI operation in SO_x Emission Control Areas, how to comply*. Oslo: Author.

4.4. Lubrication system

The change over of fuel sulphur content in many cases brings about lubrication problems if the sulphur fuel does not match with optimum lubricant oil. The combustion process of the fuel sulphur content will produce sulphuric acid that can be neutralized by appropriate lubrication oil. Otherwise, the excess acidity will lead to calcium ash deposit and corrosion wear on engine parts.

The Base Number (BN) of the lubrication oil is an indicator of its ability to neutralize acid. In general, the higher sulphur fuel oil will result in more acid which can be diminished by the use of higher BN and vice versa. Hence shipowners should ensure the use of lube oil with proper specification for each different sulphur fuel oil and dedicated storages for ship operations within and outside SECA.

Most references (Aabo, 2007, p. 40 and Wäertsillä, 2006) recommend a 70BN cylinder oil for fuel with sulphur content > 1.50% to two-stroke engines, whereas

below this percentage 40BN cylinder oil is the best. Using 1.50% sulphur fuel or below and cylinder oil at 70BN will create calcium compound deposit on piston crowns and piston ring grooves resulting in bore polishing on the cylinder liner wall. However, a 70BN lube can still be used with low sulphur fuel provided that the feed rate is reduced to the minimum (Wärtsillä, 2006). This operation can be extended from 5 to 15 days (DNV, 2005). Consuming a 70BN cylinder oil less than 15 days is more than enough for ships operating within SECA before going to the global sulphur cap area. In fact, such operation makes engines vulnerable in the long term. Therefore preventive measures should be taken by controlling cylinder liner temperature regularly and checking cylinder liner, piston surface and piston rings under ship's planned maintenance systems.

Conversely, operating with high sulphur fuel oil (> 1.50%) with a 40BN cylinder oil can provoke corrosion in the cylinder liners since a 40BN has lower ability to minimize high sulphuric acid from high sulphur fuel oil. Although the feed rate can be increased to compensate its ability, it would lead to over lubrication. Experiences show that over lubrication can either create deposits effecting ring movement or rubbing the cylinder and scrapping off the oil film, in turn leading to metal to metal contact between the piston rings and liner (Low sulphur, 2006),.

The aforementioned problems of change over of different sulphur fuel oils are not really expected for four-stroke engines. According to Welsh (2002), this is possibly because the lubricant is matched to fuel sulphur content and measures have been implemented to prevent bore polishing. However, regular inspection should be conducted on engine parts as abovementioned to prevent scuffing and corrosion problems similar to two-stroke engines. The fact is that damaging effects on four-stroke engines in the long term (Payer, 2007) should be taken into account by shipowners to take any necessary measures with respect to manufacturer advice.

4.5. SO_x emission measurement

The compliant SECA requirement of ships is proved by checking the Bunker Delivery Note (BDN) and taking samples of the fuel oil, and then analyzing it in a laboratory. The fuel analysis is time consuming and quite expensive. Furthermore,

there is no guarantee that the information on sulphur content in fuel as specified on the BDN is the same as the actual fuel which is delivered onboard. Discrepancy of sulphur content in fuel oil between the BDNs and fuel samples are reported by the Maritime Coastguard Agency (MCA) to IMO (IMO, 2008c). According to MCA, there were 7 vessels with a sulphur content of fuel oil exceeding 1.50% although the BDNs of those vessels stated sulphur content lie in the range between 1.35% and 1.49%. Most bunkers were supplied from the port of Rotterdam which is the largest bunker port in Europe. In this case, the PSC officers are obliged to inform the Party under whose jurisdiction a BDN was issued, so that the Party can take appropriate actions against fuel oil suppliers as stipulated in Regulation 18 of MARPOL Annex VI.

Nevertheless, there is a problem if PSC officers inform the non-compliant fuel oil to the Party but the Party has not yet registered local suppliers of fuel oils. According to the Voluntary IMO Member State Audit Scheme (VIMSAS), which was conducted in Sweden from 22-29 January 2007, there was no register of local suppliers of fuel oil that could be shown and no monitoring of suppliers of the quality of fuel as required (Sweden, 2007b). How can a party take appropriate measures without a list of local suppliers? Thus the Swedish Maritime Administration did not comply with regulation 18 (7)(a) and (c), despite the fact that Annex VI entered into force in May 2005.

There is a possibility to make up information in the SECA documents because the checking method of SECA compliance is carried out by looking through the documents. Experienced PSC officers, who carry out inspection thoroughly, can detect suspicious documentations. Otherwise, substandard ships can sail freely without detention. Alternative methods to avoid such problems are needed through emission surveillance as follows:

4.5.1. Airborne Surveillance

In the North Sea, the close cooperation on airborne surveillance among contracting parties is performed to detect oil spillage and other harmful chemical substances under the auspices of the Bonn Agreement through including joint surveillance

operations and exchange of information. Similar cooperation in Baltic Sea was established in the HELCOM among HELCOM contracting parties.

In practice, the airborne surveillance of oil pollution can be integrated to monitor also compliant exhaust gas emissions from ships. The airborne control of exhaust gas emissions makes it possible to detect the violation of emission restriction provisions in advance, before PSC officers inspect onboard, to cover a wide area of emission control and to secure evidence against air polluters. The aforesaid advantages of airborne surveillance are expected to support current air emission inspections while ships are in ports.

In 2007, Sweden submitted information regarding a pilot project of airborne surveillance of air emissions from ships within the Baltic Sea in August 2007 (IMO, 2007b). The project, which was conducted by Chalmers University of Technology researchers, attempted to measure SO_x, NO_x and CO₂ emissions from ships using two types of remote sensing equipment: Differential Optical Absorption Spectroscopy (DOAS), which measures remotely based on spectroscopy absorption in the ultra violet and sniffer measurement, which extract directly from the plume by means of sonde. Two types of equipment were installed in a Swedish Coastguard airplane. To perform maritime surveillance, an airplane should have ability to fly with slow speed, long endurance and low altitude and to take off and land on a short runway.

4.5.1.1. Differential Optical Absorption Spectroscopy (DOAS) measurement

Since the method relies on the natural light source from the sun, it can be categorized into the passive DOAS. The exhaust gases absorb reflected solar light from the seawater surface at different wavelengths. The light is received by a telescope. The telescope transmits light through optical fibre cable into UV spectrometer for further analysis with computers, to determine the amount of gas pollutants (Figure 4.9-left). The critical point of the equipment is the pointing angle of the telescope as receiver of reflected light. The precise pointing angle of the telescope makes it possible to collect sufficient light for accurate measurement. The pointing angle of telescope should consider the spread of exhaust gasses, which is

influenced by wind speed and direction. Hence the pilot's capability will be helpful in placing the airplane in the right position over the plume. Otherwise, several cycle manoeuvres should be done to obtain sufficient measurements.

N. Berg, which is a researcher from Chalmers University of Technology, wrote that "optical measurement is done at higher altitude, 600-800 feet" (personal communication, July 20, 2009). The DOAS measured SO₂ and also NO₂ emissions when the airplane flew over plume. As can be seen in Figure 4.9-right, SO₂ emissions from an oil tanker was measured and resulted in an emission rate of about 50 kg/h (Mellqvist, Berg & Ohlsson, 2008).

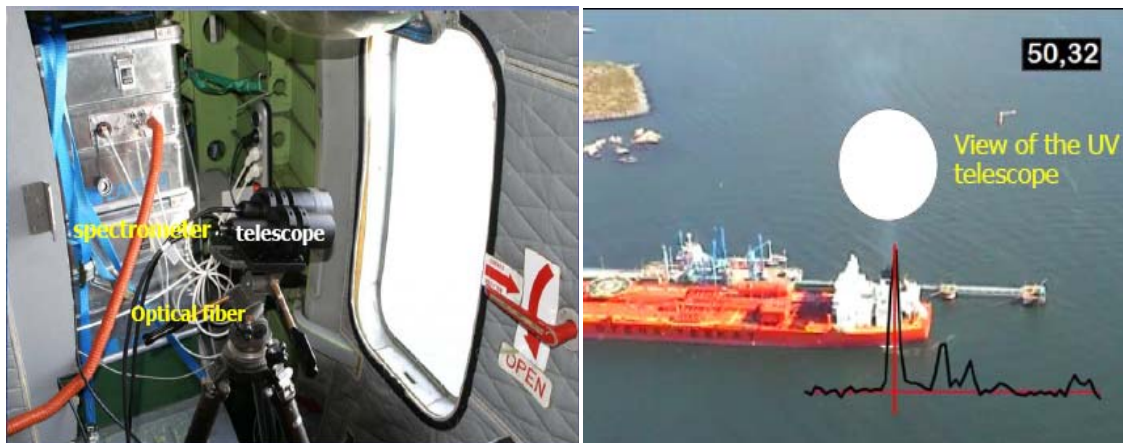

Figure 4-9. The DOAS instruments (left) and optical measurement of an oil tanker (right)

Source: Mellqvist, J., Berg, N., & Ohlsson, D. (2008). *Remote surveillance of the sulphur content and Nox emissions of ships*. Retrieved November 4, 1999 from the World Wide Web: http://www.dcmr.nl/binaries/publicatie/2008/lucht/conference_haqcc/2905_1_1_mellqvist.pdf

The equipment of the DOAS method in this project is relatively simple such as a small telescope as light receiver, UV spectrometer, computer and Automatic Identification System (AIS). The AIS is used to identify the position of the ship and relevant information of the ship, such as name, speed, course and destination. Another advantage is that there is no need for artificial light source since the instrument utilizes solar light.

Nevertheless, there are also disadvantages of the DOAS method. The availability of solar light is an essential factor. Thus the method can not be applicable to measure

ship emissions at the night and on cloudy days, although ships operate 24 hours, either in seas or ports. The solar light is not the only one light source. In fact, stars and the moon light can be utilized to measure air emissions (Platt & Stutz, 2008). However, the method requires a sensitive receiver to collect star and moon light, since their light intensity is lower than solar light. Although the moon and star light is possible in theory, the effectiveness of air emission measurement is unclear. Therefore, the solar light source is still the only reasonable and reliable method of the DOAS.

The DOAS measurement unit is in kg/h. Consequently, it is not in the acceptable SO_x emission standards according to regulation 14 (a) and (b). Either sulphur content in the fuel is not more than 1.50% or exhaust gas contains less than 6.0 g/kW.h. Therefore, the emission rate from the aforementioned measurement of about 50 kg/h should be converted to the abovementioned standard to determine whether or not the ship complies with the emission requirement and the result has reached desired accuracy.

4.5.1.2. Sniffer measurement

The sniffer system extracts gasses through a sonde that sticks out 50 cm below the airplane at an altitude of about 50-100 m from the gasses (Mellqvist et al, 2008). A sonde is connected to several gas analyzers depending upon the object of emissions to be quantified. In the case of measuring sulphur content in fuel, SO₂ and CO₂ analyzers are appropriate, because most sulphur oxides and carbon oxides would be expected in the form of SO₂ and CO₂.

Incoming SO₂ and CO₂ gasses are analyzed to quantify the mass of SO₂ and CO₂ gasses. The sulphur content in fuel oil can be calculated from the mass ratio of fuel sulphur to fuel carbon. It should be noted that SO₂ emissions emanate from the sulphur content in the fuel and in its ashes, while CO₂ emissions are based on the carbon content of the fuel. The installation of sniffer equipment is depicted in Figure 4.10.



Figure 4-10. The scientist of Chalmers installing the sonde in the airplane

Source: International Maritime Organization. (2007b, October 5)

Figure 4.11 shows the ratio of SO₂ (ppb) to CO₂ (ppm) from several ships. According to calculation, the respective ships consume fuel oil with sulphur content in the range between 0.50% and 1.70%. For example, M/V Stadion Gracht used fuel oil with sulphur content of 1.50% with the ratio between SO₂ to CO₂ around 1.7 (ppb/ppm).

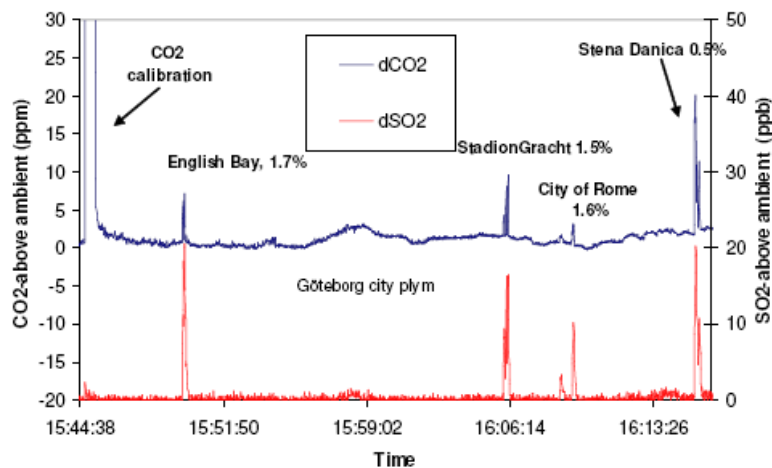

Figure 4-11. Mixing ratios above ambient conditions for SO₂ and CO₂ to determine sulphur content in fuel oil

Source: Mellqvist et al (2008)

IMO uses the SO₂/CO₂ ratio with different measurement units, namely ppm/%. The SO₂/CO₂ ratio can be used robustly at any point of operation (The International,

2006). IMO uses this ratio to monitor exhaust gas from scrubbers where the emission value does not exceed 65 (ppm/%) which corresponds to 1.50% or 6.0 g/kW.h.

The accuracy of sniffer measurement is under uncertainty so the result may deviate from the actual fuel that was used onboard. The uncertainty of measurement due to gasses calibration is estimated approximately $\pm 0.20\%$ from 1.50% (Mellqvist et al, 2008). The uncertainty over 0.20% from sulphur content limit is unacceptable since IMO interpretation requires the range of sulphur limit in fuel oil to be between 1.42% and 1.50%. The uncertainty might be minimized by frequent equipment calibration before and after measurement. Furthermore, the accuracy can be improved by arranging the sonde position properly to increase the probability of extracting the plumes so that optimum measurement can be achieved.

The sniffer measurement is more suitable for identifying sulphur content in fuel used onboard rather than the passive DOAS. The sniffer result is the percentages of sulphur content in fuel oil while the result of passive DOAS is the weight of SO₂ in the period of time (kg/h). Thus the DOAS result can contribute to establishing the real emission inventory from ships based upon field measurement. Nevertheless, passive DOAS is not efficient to quantify emissions from a considerable number of ships during a long period with airborne surveillance. Furthermore, sniffer measurement is relatively more accurate than the passive DOAS because the sniffer equipment can be calibrated frequently. However, passive DOAS measurement is affected by solar light intensity which will depend upon the weather condition that will impact on its accuracy.

4.5.2. Land surveillance

Land surveillance is another alternative to monitor air emissions from ships by utilizing active DOAS. The active DOAS uses an artificial light source from an emitter instead of solar light, which minimizes the uncertainty and improves the accuracy. An emission monitoring station can be built in the port area for example at the inlet channel of a port. It is a strategic place to measure the plume which is released from ships when they pass through the channel to berth. Therefore, none

of ships can avoid inspection. Another relevant place to install active DOAS is under bridges for example the Great Belt Bridge in Danish Waters. It is a strategic place to measure air emissions from ships when leaving and entering the Baltic Sea SECA because it is close to the border between the Baltic Sea and the North Sea, which is bounded by the parallel of the Skaw in the Skagerrak at 57°44'.8 N.

The active DOAS is an appropriate method since a receiver can be installed at a station and an emitter across the channel. Under the bridge, the receiver is fixed opposite the emitter along the bridge. The active DOAS is preferred to the sniffer instrument because it is more difficult to reach the plume from ships with a sonde.

There are three main components in this method, namely receiver, emitter and analyser. The emitter transmits a beam of light, which has a range of wavelengths, to the receiver. The air pollutants from ships absorb the light between emitter and receiver and result in different wavelengths subject to the pollutant characteristics. The various wavelengths of pollutants will be taken in a receiver and then sent to an analyzer. The rest of the process is similar to passive DOAS in the airplane. The passive and active DOAS require AIS to identify the ships which are the objects of emission measurement.

One of the DOAS problems is how to convert kg/h into acceptable emission standards according to the IMO requirement. The unit of emission restriction standards for the scrubber is g/kW.h. This unit may be applicable to the DOAS measurement provided that all engine powers (kW) in operation at that time are known. However, according to IMO, the emission value of the scrubber unit would meet the required limit of 6 g/kW.h when used with a fuel oil of 4.50% sulphur. Consequently, the limit of exhaust gas from the scrubber should be calculated with fuel oil with sulphur content of 1.50% to meet IMO requirement as per regulation 14(4)(a). Extrapolating from aforementioned standards, the use of 1.50% sulphur fuel oil will limit exhaust gas to 2 g/kW.h. The result of the DOAS measurement (kg/h) divided by engine powers (kW) must not exceed 2 g/kW.h. Therefore, the use of active DOAS at a station to monitor SO_x emissions from ships when they enter the port or pass the bridge is very promising.

4.5.3. Automatic Identification Systems (AIS) data use in SO_x emission estimation

4.5.3.1. The uncertainty of fuel oil estimation

Uncertainty in fuel consumption prediction is a common problem in ship emission inventory studies. The discrepancy of fuel consumption has raised a dispute regarding the validity of method and output. Currently, there are two methods to establish the global fuel consumption for international shipping, namely the top down approach and the bottom up approach. The former approach concentrates on the report of quantity of marine bunker fuels from oil companies delivering bunker oil to shipping companies. The database of marine bunkers is collected by the Energy Information Administration (EIA) and the International Energy Agency (IEA). The bottom up approach focuses on the specification of main and auxiliary engines onboard from Lloyd's Fairplay database and operational data from shipowners in order to calculate the fuel consumption. The information from Lloyd's Fairplay database and from shipowners is the first source to obtain engines' ship characteristics and ship movements respectively. The prediction of air emissions can be obtained from the multiplication between the fuel consumption and emission factors. Thus, accurate fuel consumption is expected to produce a reliable ship emission projection.

There is a tendency that top down approach is not a viable method to predict fuel consumption. Psaraftis and Kontovas (2009, p.4) revealed that IEA and EIA define international bunkers differently. IEA calculates the statistic of international bunker consumption including consumption by navy vessels, while EIA includes some international jet fuel in its statistic. Furthermore, Eyring et al (2005) urged that sales of marine fuel are poorly accounted for in the current reporting system because it stagnated or declined while the international ship number grew over time. It is possible because the oil companies may not really be involved in the bunkering business because they sell the fuel to bunker agents. Therefore, bunker agents may report bunker sales in different ways without uniform interpretation.

IMO (2000) predicted fuel consumption in 1996 (138 million tonnes) by means of the top down approach. It seems like IMO's estimation is also inaccurate. Airborne emission inventories which rely on inaccurate estimation in fuel consumption will mislead policy makers to formulate appropriate measures regarding ship emission reduction. Consequently, IMO (2009c) improved its estimation by using two approaches simultaneously to forecast fuel consumption in 2007. However, IMO predicted fuel consumption in 2007 accounted for 333 million tonnes higher than fuel consumption in 2012 according to Corbet et al (299 million tonnes). In this case, Corbet et al calculated fuel consumption by the bottom up approach. It is difficult to judge which estimation is more accurate by using one approach or two approaches at the same time.

4.5.3.2. Ship movement based upon AIS

The bottom up approach or activity based method is more accurate than the top down approach. It is possible because the bottom up approach collects information from the first source and the uncertainty of calculation can be minimized by the sensitivity analysis method for uncertain inputs and assumptions. Nevertheless, the potential problem of the bottom up approach is information regarding ship movements.

Firstly, information about ship movements relies on AMVER and ICOADS databases (chapter 2) which have several limitations. For example, AMVER is the voluntary global ship reporting system. That information is collected from participating ships (AMVER, 2009), whereas ICOADS database compiled information from cargo and passenger ships only (Corbett et al, 2007). Secondly, the ship distribution from those databases depicts the simple navigation routes, such as straight lines from port to port. Consequently, the real ship movement can not be captured when ships enter or leave ports. Estimation relies on those databases ignoring the variation of ship's speed and the real ship's distance during its operation. Thus ignorance of the real ship speed and travel distance will produce inaccurate fuel consumption estimation, which leads to a rough prediction of emissions.

The HELCOM AIS system is a very promising tool to collect the above stated data in real time and the image of ship's traffic situation in the Baltic Sea area in order to quantify accurate SO_x emissions. HELCOM AIS is the integrated system between ships and land based stations which are installed in the area of HELCOM contracting parties surrounding the Baltic Sea. The real time data of ship movement is more accurate because the AIS sends information including ship position, course and speed every few seconds. Consequently, it obviates many assumptions about route distances and ship speed. Furthermore, most ships with a tonnage > 300 GT engaged in international voyage, cargo ships of 500 GT and above not engaged in international voyages and all passenger ships irrespective of size are covered by AIS (IMO, 2009g). Moreover, the scrubber technology enables exhaust gases and washwater discharge to be recorded and stored along with GPS information (Krystallon, 2009a). There is a possibility that the amount of emissions can be displayed in the AIS, since MCA considers the approval of an electronic system using GPS/AIS in conjunction with scrubbers (Thomas, 2007). The quantification of emissions is directly from readings on AIS (6 g/kW.h), and relevant data such as engine power and the duration of scrubber operation can also be used to establish emission inventory.

However, AIS can not identify the operation of auxiliary engines, therefore either Lloyd's Fairplay database or ship register book from classification societies remain to be used to collect information about auxiliary engine specification. In a nutshell, the real time ship movements and the numerous ship observations will improve the projection of ship emission inventories. Thus the reliable SO_x emission inventories can provide strong evidence for evaluating IMO regulations for further environmental measures.

4.6. The future scenario of SO_x emission monitoring

There is an urgent need to monitor emissions from ships since the low sulphur fuel is more expensive than the high sulphur ones. Ships may still use high sulphur fuel when entering SECA and crews make up the SECA documentation to cover their illegal actions. In the near future, the more stringent emission monitoring will reduce illegally exhaust discharge exceeding the SECA standard. Two surveillance layers

to measure sulphur content in fuel oil from ship's exhaust gases, namely airborne and land surveillance will make PSC officer's job to enforce the SECA regulation easier.

Airborne surveillance will be performed mostly in the border area of SECA to monitor that either the change over process to low sulphur fuel took place before entering SECA or that the ships still use low sulphur fuel before going out from SECA. The airplanes can also randomly check ships within SECA to ensure low sulphur fuel implementation. Once the scrubber technology in conjunction with AIS has been widely installed onboard, PSC officers will easier track emissions and washwater discharge from AIS in their station. Furthermore, the AIS also can inform about the non scrubber vessels. This message is received by land based stations and will then be forwarded to operators in the airplanes. Therefore, the airborne surveillance may be preferred to monitor non scrubber vessels. For the sake of this purpose, the information about emission levels from scrubbers is expected to be covered in the AIS in the next few years.

Airborne surveillance is very useful for the US and Canadian ECA with a large area of emission control. Some ships, which pass through the ECA without berthing at US and Canadian ports, may disobey the regulation. The violation of emission standards found by airborne surveillance will be reported to PSC officers to take actions as appropriate against ship's crews. In this case, a data recorder from surveillance is used against polluters. Checking the BDN and taking sample fuel oil to laboratory is necessary to support evidence. However, the flexibility and ability of airplanes to move fast and do emission measurement may not be enough to cover all ships within a control area. Thus land based surveillance is the second effort to monitor emissions when ships approach ports.

The discussion regarding emission surveillances and emission inventory estimation shows that the AIS is a central point of the system as can be seen in Figure 4.12. In the future, the AIS will play a significant role in integrating the system. The final information of the system can be used by IMO to improve the efforts to protect the environment and human health from ship emissions.

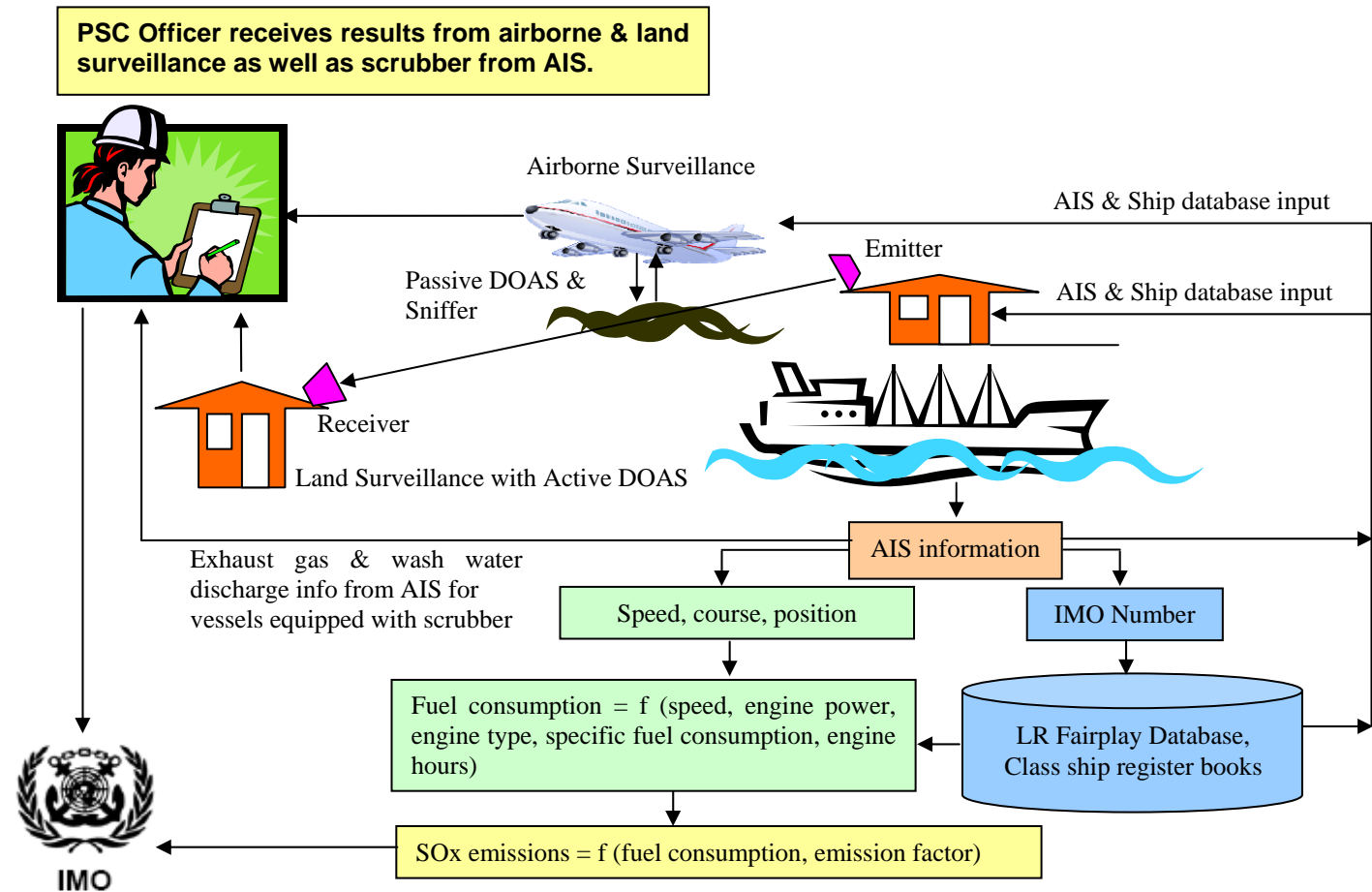

Figure 4-12. The integrated system of airborne surveillance, land surveillance, exhaust gas monitoring and SO_x emission inventory

Source: Author, 2009

4.7. The SECA loop system for effective implementation

The SECA loop system is series of causal factors to achieve effective SECA implementation (Figure 4.13). The factors of SECA loop comprise SECA planning, SECA execution, SECA monitoring and SECA evaluation. The SECA planning is the basic requirement of SECA as stipulated in Regulation 14(4)(a),(b) & (c). In this case, the dissertation has discussed the availability of marine fuel at 1.00% and 0.10% sulphur content and the alternative methods: scrubbers and LNG. The SECA execution requires shipowners, flag states, port states and other relevant parties to carry out SECA planning. In this part, the author focuses on identification and discussion of the problems of using low sulphur fuel oil, since it is the most common method to reduce SO_x emissions. The SECA monitoring is the process of output measurement to ensure the SECA compliance of ships and to establish SO_x emission inventories.

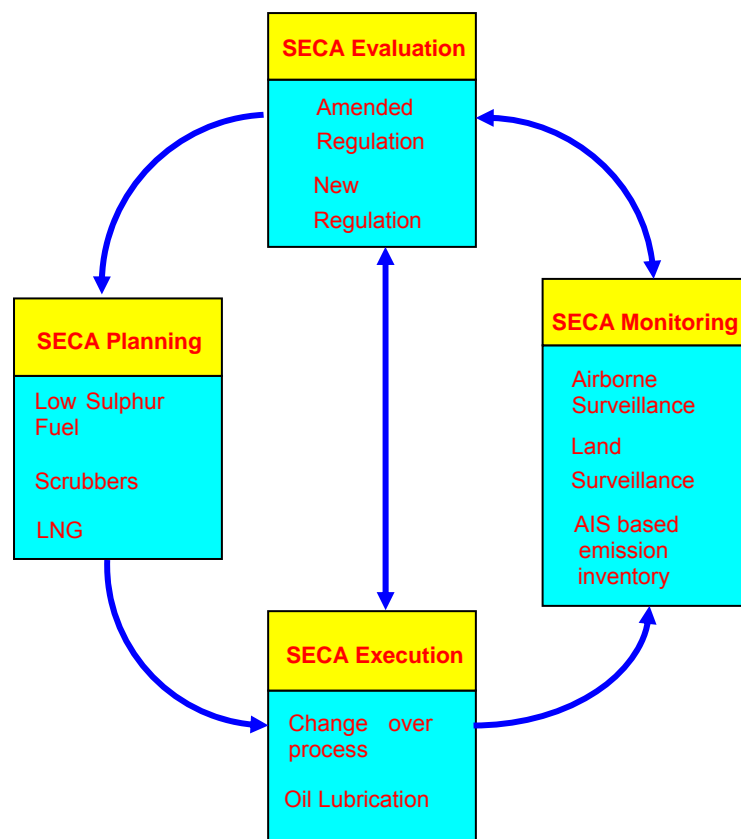

Figure 4-13. The SECA loop system for effective implementation

Source: Author, 2009

Feedback from the SECA execution and the SECA monitoring will be used by IMO member states to evaluate existing SECA regulations. However, the SECA planning may not provide feedback to the SECA evaluation unless planning has been carried out and problems are found. Feedback may contain either problems or recommendations that should be addressed by IMO. The result of the evaluation may develop either amended SECA regulations or new SECA regulations. It is expected to improve the current process in the SECA planning (i.e. more limitation in sulphur content of fuel oil), the SECA execution (i.e. the revision of wash water discharge) and the SECA monitoring (i.e. new method of SO_x emission monitoring).

In fact, the discussion in Chapter 4 can be considered as the improvement process to respond to problems related to the non effective SECA implementation, which is derived from the Ishikawa diagram. Accordingly, the continuous improvement based upon the loop system is expected to increase effective SECA implementation and will contribute to SO_x emission reduction gradually.

CHAPTER 5

CONCLUSIONS AND RECOMMENDATIONS

5.1. Conclusions

This dissertation has attempted to guide the reader through the latest development of shipping operations related to ship traffic distribution concentrated in coastal areas. The dissertation has highlighted selected sea areas, namely the Baltic Sea, the North Sea, the Mediterranean Sea, the US and Canadian waters and the Straits of Malacca, which suffer SO_x, NO_x and PM emission effects from the ships. The effects of these emissions on the environment are in the form of eutrophication and acidification, while human health damage relates to premature death caused by respiratory diseases.

Great emphasis has been placed on the regulation to limit SO_x emissions in order to minimize acidification by implementing SECA in the Baltic Sea and the North Sea from 2006 and 2007 respectively. Although regulation 14 of MARPOL Annex VI concerning SECA has been fully enforced since 2006, the effectiveness of the SECA regime to reduce SO_x emissions is questionable because statistics show SO_x emissions remain increasing until 2030.

The dissertation reveals that the SECA scheme may not be effective enough to reduce SO_x emissions because of several problems which are identified by the Ishikawa Diagram. The problems include, but are not limited to, the availability of marine fuel, the complexity of the switching over process to low sulphur fuel, the use of lubrication oil, the monitoring of SECA compliance onboard ships and the uncertainty of SO_x emission inventories. These problems predominantly influence the whole process to reach effectiveness in SECA implementation. Therefore, the dissertation deals with the aforementioned problems to produce technical and operational solutions in the framework of SECA loop system (Figure 4.13).

The SECA loop system is a series of causal factors which consists of the SECA planning, the SECA execution, the SECA monitoring and the SECA evaluation. The operational and technical solutions in the framework of the SECA loop system are the cycle of the improvement process which should be performed to achieve effective SECA implementation in decreasing SO_x emissions gradually.

5.1.1. The SECA planning

The SECA planning is the essence of the SECA regulation because it contains the methods to reduce SO_x emissions, which will influence the rest factors in the SECA loop. The low sulphur fuel is the primary method to reduce SO_x emissions. However, its availability will be uncertain to supply vessels from 2015 and onwards. The dissertation identifies that the environmental motive pressures are stronger to influence such decision rather than the technical justification related to the capacity of oil refineries to produce low sulphur fuel oil. In the case of the global sulphur cap to limit sulphur content in fuel to 0.50% in 2020, a review of this provision must be completed by 2018 to determine the availability of such fuel oil. Nevertheless, there is no provision review to identify the fuel oil availability in order to implement SECA in 2015.

There are two implications of the limited availability of low sulphur fuel. Firstly, many potential sea areas may not be declared as SECA in the next few years considering the fuel oil availability, for example the Mediterranean Sea area. If the Mediterranean Sea has not been designated as SECA, it will lessen the benefit of the North Sea SECA in countries which are close to the Mediterranean Sea, for example, France.

Secondly, shipowners have attempted to find the alternative methods, namely scrubbers and LNG to minimize SO_x emissions. Switching to scrubbers and LNG is fairly economically influenced by the price of low sulphur fuel compared with those methods. From 2015, the low sulphur fuel will be more expensive and that will force shipowners to install scrubbers, although they are still uncertain about PSC response against wash water discharge. Although the price of LNG is relatively lower than HFO and low sulphur fuel since 2008, the difficulties in retrofitting existing

vessels and the considerable demand of sufficient LNG tanks onboard ships are the main drawbacks. However, the short sea shipping trade in the Baltic Sea and the North Sea SECA will cause more and more ships to use LNG since the natural gas supply is abundant and the role of the respective states in these regions encourage using more environmentally friendly energy sources.

5.1.2. The SECA execution

The change over process to low sulphur fuel is another problem in the SECA execution. Since different engines and different fuel systems have different characteristics, there is no simple uniform change over standard available. Consequently, the PSC officer should extra carefully check the change over procedure in ships with single settling/service tank, especially to ensure that the change over process has been completed before entering into a SECA. PSC officers may need training to improve their ability to deal with change over problems to avoid uncontrolled substandard ships. Furthermore, the class society or maritime administration approval of the change over manual may be required to improve the validity of the change over process for each engine.

The single tank system is not recommended for ships with more frequent visits in SECA, because there is an increased probability of unintentionally stopping the engine. The dual tanks system is the feasible solution to operate within SECA because it reduces problems related to the change over process. In the same case, the use of 40BN and 70BN cylinder lube oil is suitable for low and high sulphur fuel, especially for two stroke engines. Four stroke engines have no specific standard of lubrication oil but potential problems similar to two stroke engines should be anticipated.

It seems that the use of scrubbers replaces the air emission problems with marine pollution because washwater discharges from scrubber might create ocean acidification. Accordingly, the use of freshwater scrubber is recommended. The freshwater scrubber system can periodically be operated without discharging wash water overboard. Hence, it will minimize wash water discharge into the sea and reduce the adverse effects of scrubber in the sea environment. Furthermore, the use

of fresh water scrubber onboard ships in the Baltic Sea is better than seawater scrubbers considering the brackish water of the Baltic Sea.

5.1.3. The SECA monitoring

In the SECA monitoring, Automatic Identification Systems (AIS) is the central point of integrated systems among airborne surveillance, land surveillance, exhaust gas monitoring and SO_x emission inventories (Figure 4.12). The AIS provides real time information related to ship movement (speed and direction) which is useful information to calculate sulphur content in the fuel oil and emission inventory. The final result of the integrated system can be used by IMO to improve the efforts to protect the environment and human health from ship emissions

The sniffer measurement is recommended to be used in airplanes because its reliability to measure the plume, while the active DOAS is the effective method in land surveillance where it can be installed in ports and under bridges. In the case of the Baltic Sea SECA, the dissertation emphasizes active DOAS equipment to be installed under the Great Belt Bridge and other bridges such as Oresund Bridge and Kiel Canal Bridge to monitor the compliant of sulphur fuel oil is used onboard ships within the SECA. Furthermore, the exhaust gas monitoring from scrubbers is possible to be displayed in the AIS. The synergy among airborne surveillance, land surveillance and scrubber is expected to provide preliminary information regarding the compliant SO_x emissions and sulphur content in fuel to PSC officers in order to conduct further inspection onboard effectively. If necessary, oil testing in laboratory may be carried out to support data recorded from surveillance. This future scenario will improve the SECA compliance of ships and reduce the effect of misleading information from the BDN.

The accuracy of SO_x emission inventory is essential to support the decision makers to take appropriate measures related to the effort to reduce SO_x emissions. There are many uncertainties of SO_x emission data collection caused by measurement methods, data reliability and unrealistic assumptions. The bottom up method in conjunction with AIS information can eliminate the unrealistic assumptions such as

ship's travel distance and ship's speed and improve the data reliability related to ship's fuel consumption.

5.1.4. The SECA evaluation

The SECA evaluation is based on a feedback mechanism from the SECA execution and the SECA monitoring. The SECA evaluation involves the role of IMO in formulating the amended SECA regulations and the new SECA regulations which have an impact on the performance of the SECA planning, execution and monitoring. The dissertation shows that the IMO decisions related to the use of low sulphur content in fuel heavily rely on the capacity of oil refinery industries. This situation might restrict the possibility for IMO to run and to fulfil its plan.

The dissertation identifies that the consistency of IMO member states to implement SECA can be revealed by VIMSAS (Voluntarily IMO Member States Audit Scheme) for example in Sweden the case related to the non compliant regulation 18 of Annex VI. The audit enables the role of member states as flag states, port states and coastal states to be assessed and correction actions can be taken to improve their roles. It is a part of SECA evaluation whether or not the SECA provision is effectively implemented by IMO member states.

5.2. Recommendations

- The SECA planning should be formulated based upon technical and economic feasibilities as well as the impact on the environment. Furthermore, the review of the availability of low sulphur fuel is required to anticipate uncontrolled problems, which will deviate the planning from the desired target.
- Further research should be carried out to investigate the fuel availability in sea areas such as the Mediterranean Sea, the straits of Malacca and its impact on the prospect of these areas to be designated as SECA.
- IMO should specify the allowable limit of PM emissions in the regulations for example in the unit of gr/kW.h, and the development of PM reduction technologies is encouraged to further reduce PM emissions in order to protect human health.

- Recently, IMO requires tier III to reduce NO_x emissions within ECA, which will enter into force in 2010. Consequently, IMO should stipulate the further standards of NO_x emission reduction and their time frame after tier III has been implemented.
- In the future, the AIS should also cover exhaust gas information from ships with scrubbers to support PSC officers' jobs by enforcing SECA regulation easier.

References

- Aabo, K. (2007). Operation on low-sulphur fuels using two-stroke engines. *BIMCO Bulletin*, 102 (4), 34 – 43
- Abdulla A & Linden, O. (2008). Foreword. In A. Abdulla & O. Linden (Eds.), *Maritime traffic effects on biodiversity in the Mediterranean Sea Volume 1 - Review of impacts, priority areas and mitigation measures* (p.7). Malaga: IUCN
- Air emissions from ships – time is running out. (2008a). *BIMCO Bulletin*, 103 (1), 8 – 12
- Air emissions from shipping – status and the way ahead. (2008b). *BIMCO Bulletin*, 103 (6), 8 –21
- American Bureau of Shipping. (2007, January). Dual fuel LNGs intended for Baltic, North Sea trading will need to demonstrate SECA compliance. *Activities*, 40-41
- Alexandersson, A. (1991). *Exhaust gas emissions from sea transportation*. Stockholm: Swedish Transport Research Board
- Amann, M., Bertrok, I., Cofala, J., Gyarmas, F., Heyes, C., Klimont, Z., Schöpp, W., Winiwarter, W. (2004) *Baseline scenarios for the Clean Air For Europe (CAFE) Programme. Report Contract B4- 3040/2002/340248/MAR/C1*. Brussels: The European Commission, DG Environment.
- AMVER. (2009). *AMVER density plot display*. Retrieved June 10, 2009 from the World Wide Web: <http://www.amver.com/density.asp>
- Andersson, P., Håkansson, B., Håkansson, J., Sahlsten, E., Havenhand, J., Thorndyke, M., & Dupont, S. (2008). *Marine Acidification on effects and monitoring of marine acidification in the seas surrounding Sweden (Rep. No. 92, 2008)*. Stockholm: The Swedish National Environmental Protection Agency
- Andreasen, A. & Mayer, S. (2007). Use of Seawater Scrubbing for SO₂ Removal from Marine Engine Exhaust Gas. *Energy & Fuels*, 21, 3274–3279
- Arvidsson, B. (2007). Swedish reports backs emission trading. *BIMCO Bulletin*, 102 (6), 48 – 49
- Bravo, A. H., Soto, A. R., Sosa, E. R., Sánchez, A. P., Alarcón, J.A.L., Kahl, J., & Ruíz, B. J. (2006). Effect of acid rain on building material of the El Tajín archaeological zone in Veracruz, Mexico. *Environmental Pollution*, 144 (44), 650 – 660
- Brukner-Menchelli, N. (2009, May/June). Scrubbers versus distillates. *Bunker world*, 24. Retrieved July 20, 2009 from the World Wide Web:

<http://i.pmcndn.net/p/bw/magazine/2009/05/2009-05-Scrubbers-versus-distillates.pdf>

Bunker word. (2009). *Rotterdam Daily Bunker Prices*. Retrieved July 10, 2009 from the World Wide Web: <http://www.bunkerworld.com/markets/prices/nl/rtm/>

Californian Environmental Protection Agency. (2007, June 13). *2nd Public workshop to discuss development of regulations for ocean-going ship main engines*. Retrieved June 25, 2009 from the World Wide Web: <http://www.arb.ca.gov/ports/marinevess/presentations/061307/061307ogvpres.pdf>

Canada's Federal Marine Protected Areas Strategy. (2005). Ottawa: Communications Branch Fisheries and Oceans Canada

CE Delft, Germanischer Lloyd, MARINTEK, Det Norske Veritas. (2006). *Greenhouse gas emissions for shipping and implementation guidance for the marine fuel sulphur directive (Rep. No. 06.4103.61)*. Delft, The Netherlands: CE Delft.

Clark, R.B. (2001). *Marine Pollution, 5th edition*. New York: Oxford University Press

Cofala, J., Amann, M., Heyes, C., Wagner, F., Klimont, Z., Posch, M., Schöpp, W., Tarasson, L., Jonson, J.E., Whall, C., & Stavrakaki, A. (2007). *Analysis of Policy Measures to Reduce Ship Emissions in the Context of the Revision of the National Emissions Ceilings Directive IIASA Contract No. 06-107*. Luxemburg: International Institute for Applied Systems Analysis (IIASA)

CONCAWE. (2006). *Techno-economic analysis of the impact of the reduction of sulphur content of residual marine fuels in Europe. (Report nr. 2/06)*. Brussels: Author

Corbett, J.J., Fischbeck, P.S., & Pandis, S. N. (1999). Global Nitrogen and Sulfur Emissions Inventories for Oceangoing Ships. *Journal of Geophysical Research*. 104, 3457-3470.

Corbett, J.J., & Farrell, A. (2002). Mitigating air pollution impacts of passenger ferries. *Transportation Research Part D* 7, 197–211

Corbett, J.J., Winebrake, J.J., Green, E.H., Kasibhatla, P., Eyring, V., & Lauer, A. (2007). Mortality from Ship Emissions: A Global Assessment. *Environmental Science Technology*, 41, 8512-8518

Det Norske Veritas. (2005). *Regulations for the Prevention of Air Pollution from Ships Technical and Operational implications*. Oslo: Author.

Det Norske Veritas. (2006). *MARPOL Annex VI operation in SO_x Emission Control Areas, how to comply*. Oslo: Author.

- Distilling the argument. (2007, February). *Marine Engineers Review*, 12 – 16
- Doney, S.C., Mahowald, M., Lima, I., Feely, R.A., Mackenzie F.T., Lamarque, J-F, Rasch, P.J.(2007). Impact of anthropogenic atmospheric nitrogen and sulfur deposition on ocean acidification and the inorganic carbon system. In M.L. Bender (ed). *Proceedings of the National Academy of Sciences of the United States of America*, 104 (37), 14580 - 14585
- Ducrotoy, J.P. & Elliot, M. (2008). The science and management of the North Sea and the Baltic Sea: Natural history, present threats and future challenges. *Marine Pollution Bulletin*, 57, 8-21
- Ehlers, P. (2008). Effects on maritime transportation. In N. Bellefontaine & O. Linden (Eds.). *In proceedings of the conference on impacts of climate change of the maritime industry* (pp. 43 – 54). Malmö: World Maritime University
- Einang, P.M. (2007, May 2). LNG as fuel for ships in short sea shipping. *Review MARINTEK*, 9 – 11. Retrieved July, 15 2009 from the World Wide Web:http://sintef.org/upload/MARINTEK/Review%202-2007/Review_2-2007.pdf
- Einang, P.M. (2009). *New emerging energy sources and systems. MARINTEK seminar at NorShipping 2009*. Retrieved July, 12 2009 from the World Wide Web:
http://www.sintef.no/project/NorShipping2009_Seminar/Energy_sources_systems_Einang.pdf
- Einemo, U. (2008, May/June). MARPOL Annex VI revision signals new low-emissions. *Bunker World*, 6 – 8
- Endresen, O., Sorgård, E., Sundet, J.K., Dalsoren, S.B., Isaksen, I.S.A., Berglen, T.F. & Gravir, G. (2003). Emission from International Sea Transportation and Environmental Impact. *Journal of Geophysical Research*, 108, 1 – 22
- Environmental Protection Agency. (2009a). *Effects of Acid Rain - Surface Waters and Aquatic Animals*. Retrieved June, 20 2009 from the World Wide Web:
http://www.epa.gov/acidrain/effects/surface_water.html
- Environmental Protection Agency. (2009b). *Proposal of Emission Control Area Designation for Geographic Control of Emissions from Ships*. Ann Arbor: Author
- Environmental Protection Agency. (2009c). *Diesel boats and ships*. Retrieved June, 20 2009 from the World Wide Web:
<http://www.epa.gov/otaq/marine.htm#2008final>
- European Maritime Safety Agency. (2005). *Study on Ships producing reduced quantities of ships generated waste – present situation and future*

- opportunities to encourage the development of cleaner ships (Report No. EMSA/OP/05/05)*. Brussels: Author
- European Environmental Agency. (2006). *Priority issues in the Mediterranean environment (Report No. 4/2006)*. Copenhagen: Author
- Eyring, V., Köhler, H. W., van Aardenne, J., & Lauer, A. (2005). Emissions from International Shipping: 1. The last 50 years. *Journal Geophysical Research*, 110.
- Eyring, V., & Corbett, J.J. (2007). *Comparing Fuel Consumption, CO₂ and Other Emissions from International Shipping and Aircraft*. Retrieved June, 12 2009 from the World Wide Web:
http://www.pa.op.dlr.de/SeaKLIM/Fuel_Emissions_International_Shipping.html
- Friedrich, A., Heinen, F., Kamakaté, F., & Kodjak, D. (2007). *Air Pollution and Greenhouse Gas Emissions from Ocean-going Ships: Impacts, Mitigation Options and Opportunities for Managing Growth. The International Council on Clean Transportation*. Retrieved June, 1 2009 from the World Wide Web:
http://www.theicct.org/documents/MarineES_Final_Web.pdf
- Hannagan, T. (2007). *Management: concepts and practices*. Essex: Pearson Education Limited
- Helsinki Commission. (1994, March 11). *Report of the 15th meeting of the Helsinki commission - Baltic marine environment protection commission (Helcom 15/18)*. Helsinki: Author
- Helsinki Commission. (2005). *Airborne nitrogen loads to the Baltic Sea*. Helsinki: Author. Retrieved June, 2 2009 from the World Wide Web:
http://www.helcom.fi/stc/files/Publications/OtherPublications/Airborne_nitrogen_loads_toBS.pdf
- Helsinki Commission. (2006). Biodiversity and Nature Protection in the Baltic Sea. *Draft HELCOM Thematic Assessment in 2006*. Helsinki: Author
- Helsinki Commission. (2007). Climate Change in the Baltic Sea Area. *Baltic Sea Environment Proceedings No. 111*. Helsinki: Author
- Helsinki Commission. (2008). Activities 2007 overview. *Baltic Sea Environment Proceedings No. 114*. Helsinki: Author
- Helsinki Commission. (2009). *Baltic facts and figures*. Retrieved June, 2 2009 from the World Wide Web: http://www.helcom.fi/environment2/nature/en_GB/facts/
- Henriksson, T. (2007, February). SO_x scrubbing of marine exhaust gasses. *Wärtsilä Technical Journal*, 55 – 58. Retrieved July, 2 2009 from the World Wide Web:
http://www.wartsila.com/Wartsila/global/docs/en/about_us/in_detail/2_2007/SO_x-scrubbing-marine-exhaust-gases.pdf

- Imai, I., Yamaguchi, M., Hori, Y. (2006). Eutrophication and occurrences of harmful algal blooms in the Seto Inland Sea, Japan. *Plankton Benthos Res*, 1 (42), 71 - 84
- International Maritime Organization. (1999, December 3). *Designation of the North Sea area as a SO_x Emission Control Area: Submitted by Austria, Belgium, Denmark, Finland, France, Germany, Greece, Ireland, Italy, Luxembourg, Netherlands, Norway, Portugal, Spain, Sweden, United Kingdom and the European Commission (MEPC 44/11/4)*. London: Author.
- International Maritime Organization. (2000). *Study of Greenhouse Gas Emissions from Ships*. Trondheim.
- International Maritime Organization. (2004, July 20). *Sulphur monitoring 2003: Submitted by the Netherlands (MEPC 52/4/8)*. London: Author.
- International Maritime Organization. (2005, March 8). *Sulphur monitoring 2004: Submitted by the Netherlands (MEPC 53/4)*. London: Author.
- International Maritime Organization. (2006a, June 6). *Sulphur monitoring 2005: Submitted by the Netherlands (MEPC 55/4/1)*. London: Author.
- International Maritime Organization. (2006b, August 10). *Information on the potential of emissions trading to reduce harmful emissions into the air from ships: Submitted by the United Kingdom (MEPC 55/INF.7)*. London: Author.
- International Maritime Organization. (2007a, March 7). *Sulphur monitoring 2006: Noted by the Secretariat (MEPC 52/4/8)*. London: Author.
- International Maritime Organization. (2007b, October 5). *Information regarding airborne surveillance of exhaust gas emissions from ships: submitted by Sweden (BLG-WGAP 2/INF.4)*. London: Author.
- International Maritime Organization. (2008a, February 8). *Sulphur monitoring 2007: Noted by the Secretariat (MEPC 57/4/24)*. London: Author.
- International Maritime Organization. (2008b, April 8). *Report of the Working Group on Annex VI and the NO_x Technical Code (MEPC 57/WP.7)*. London: Author.
- International Maritime Organization. (2008c, July 10). *Bunker delivery note and fuel oil sampling - Communications received from the Administration of the United Kingdom (MEPC.1/Circ.623)*. London: Author.
- International Maritime Organization. (2008d, October 17). *Report of the Marine Environment Protection Committee on its fifty-eighth session (MEPC 58/23/Add.1)*. London: Author.

- International Maritime Organization. (2008e, November). *International Shipping and World Trade Facts and figures*. London: Author
- International Maritime Organization. (2009a February 3). *Sulphur monitoring 2008: Noted by the Secretariat (MEPC 59/4/1)*. London: Author.
- International Maritime Organization. (2009b, March 27). *Proposal to Designate an Emission Control Area for Nitrogen Oxides, Sulphur Oxides and Particulate Matter: Submitted by the United States and Canada (MEPC 59/5/X)*. London: Author.
- International Maritime Organization. (2009c, April 9). *Second IMO GHG Study 2009 Update of the 2000 IMO GHG Study Final report covering Phase 1 and Phase 2: Note by the Secretariat (MEPC 59/INF.10)*. London: Author.
- International Maritime Organization. (2009d, July 16). *Prevention of air pollution from ships & interpretations of, and amendments to, MARPOL and related instruments & reports of sub-committees - Report of the technical group on ECA and other MARPOL Annex VI related issues (MEPC 59/WP.10/Add.1)*. London: Author
- International Maritime Organization. (2009e). *Prevention of Air Pollution from Ships*. London: Author. Retrieved June 10, 2009 from the World Wide Web: http://www.imo.org/environment/mainframe.asp?topic_id=233
- International Maritime Organization. (2009f). *Special Areas under MARPOL*. Retrieved August 10, 2009 from the World Wide Web: http://www.imo.org/Environment/mainframe.asp?topic_id=760
- International Maritime Organization. (2009g). *AIS transponder*. London: Author. Retrieved July 24, 2009 from the World Wide Web: <http://www.imo.org>
- International Maritime Organization. (2009h). *Summary of status convention*. London: Author. Retrieved August 5, 2009 from the World Wide Web: <http://www.imo.org>
- International Maritime Organization. (2009i). *Particularly Sea Sensitive Areas*. London: Author. Retrieved August 6, 2009 from the World Wide Web: http://www.imo.org/Environment/mainframe.asp?topic_id=1357
- Kullenberg, G. (2008), Transportation across the sea. In C. Thia-Eng, G. Kullenberg & D. Bonga (eds). *Securing the ocean: essays on ocean governance-Global and regional perspective* (pp. 41-64). Quezon City: GEF/UNDP/IMO regional programmer on building partnerships in environmental management for seas of East Asia (PEMSEA) and the Nippon foundation
- Krystallon. (2009a). *Water and gas monitoring*. Retrieved July 21, 2009 from the World Wide Web <http://www.krystallon.com/emissions-monitoring.html>

- Krystallon. (2009b). *Ship emissions regulations overview IMO and local directives*. Retrieved July 20, 2009 from the World Wide Web: <http://www.krystallon.com/emissions-monitoring.html>
- Levander, O. (2008). Reducing local emissions by switching to LNG. *Paper presented at Motorship propulsion & emissions conference 2008*. Gothenburg, Sweden: Motorship
- Low sulphur high risk ? (2006, February). *Marine Engineers Review*, 34 – 35
- Maritime Coastguard Agency. (2009). *The Dover Strait*. Retrieved June 12, 2009 from the World Wide Web: http://www.mcga.gov.uk/c4mca/mcga07-home/emergencyresponse/mcga-searchandrescue/mcga-hmcgsar-sarsystem/channel_navigation_information_service__cnis_/the_dover_strait.htm
- Marshall, G., Rynn, P.G., Stanton, M.E., & Horn, G.E. (2007). Tanker safety-regulatory change. *WMU Journal*, 7 (1), 317-351.
- Meech, R. (2005). *Designation of the Mediterranean Sea as a SOx Emission Control Area (SECA) under MARPOL Annex VI*. A report prepared under the Project EUROMED Cooperation on Maritime Safety and Prevention of Pollution from Ships SAFEMED (MED 2005/109-573). Retrieved May 15, 2009 from the World Wide Web: [safemedproject.org/filebank/documents/task37O/Consolidated_Final_Report_\(E\).pdf](http://safemedproject.org/filebank/documents/task37O/Consolidated_Final_Report_(E).pdf) –
- Meech, R. (2009, April 28). Scrubber market from 2015. *Bunkerworld*. Retrieved July 4, 2009 from the World Wide Web: http://www.sustainableshipping.com/news/i76672/Scrubber_market_from_2015
- Mellqvist, J., Berg, N., & Ohlsson, D. (2008). *Remote surveillance of the sulphur content and Nox emissions of ships*. Retrieved July 20, 2009 from the World Wide Web: http://www.dcmr.nl/binaries/publicatie/2008/lucht/conference_haqcc/2905_1_mellqvist.pdf
- Mukherjee, P.K., Xu, J. (2008). The legal framework of exhaust emissions from ships: A selective examination from a law and economic prospective. In N. Bellefontaine & O. Linden (Eds.). *In proceedings of the conference on impacts of climate change of the maritime industry* (pp. 69 – 102). Malmö: World Maritime University
- New Report Predicts Substantial Death Toll from Under-regulated Shipping Emissions*. (2007, November 7). Retrieved November 4, 1999 from the World Wide Web: http://www.catf.us/press_room/20071107-Shipping.pdf

- Nielsen, D. (2000). Air pollution from ship – MARPOL Annex VI. *BIMCO Bulletin*, 95 (1), 18-20.
- Pawlak, J.F., Laamanen, M & Andersen, J.H. (2009). Eutrophication in the Baltic Sea - An integrated thematic assessment of the effects of nutrient enrichment in the Baltic Sea region – Executive Summary. *Baltic Sea Environment Proceedings No. 115a*. Helsinki: HELCOM
- Paladino, B. (2007). *Five Key Principles of Corporate Performance Management*. Hoboken, NJ: John Wiley & Sons, Inc
- Payer, H.G. (2007). Current debate on sulphur emissions and potential for fuel efficiency. In *4th Annual Green Ship Technology Conference : understanding the technological advances for sustainable shipping 2007*. Antwerp, Belgium: Lloyd's List
- Platt, U & Stutz, J. (2008). *Differential Optical Absorption Spectroscopy – Principles and Application*. Berlin: Springer
- Port of Göteborg. (2009). *Port tariff for the Port of Göteborg*. Retrieved July 10, 2009 from the World Wide Web: [http://www.portgot.se/prod/hamnen/qhab/dalis2b.nsf/vyFilArkiv/hamntaxa_GB_090121_web.pdf/\\$file/hamntaxa_GB_090121_web.pdf](http://www.portgot.se/prod/hamnen/qhab/dalis2b.nsf/vyFilArkiv/hamntaxa_GB_090121_web.pdf/$file/hamntaxa_GB_090121_web.pdf)
- Port of Mariehamn. (2009). *Harbour Chargers*. Retrieved July 10, 2009 from the World Wide Web: http://www.mariehamn.ax/Port_of_Mariehamn/Charges/Harbour_charges
- Psaraftis and Kontovas (2009). CO2 emission statistics fro the world commercial fleet. *WMU Journal of maritime affairs*, 8 (1), 1 – 25
- Purcell, C. (2007). President's Creel. *Nova Scotia Salmon Association – UPSTREAM, Fall 2007*, p.1. Retrieved June 12, 2009 from the World Wide Web: http://www.novascotiasalmon.ns.ca/theassociation/documents/Salmon_Newsletter_Fall07.pdf
- Quinn, P. K., Bates, T. S., Baum, E., Doubleday, N., Fiore, A. M., Flanner, M., Fridlind, A., Garrett, T. J., Koch, D., Menon, S., Shindell, D., Stohl, A., & Warren S. G. Short- lived pollutants in the Arctic: their climate impact and possible mitigation strategies. *Atmosphere Chemical Physics*, 8 (6), 1723-1735.
- Ritchie, A., de Jonge, E., Hugli, C., Cooper, D. (2005). *Ship Emissions: Assignment, Abatement and Market-based Instruments*. Cheshire, UK: The European Commission, DG Environment.
- Sea Watch Foundation. (2009). Retrieved June 17, 2009 from the World Wide Web: <http://www.seawatchfoundation.org.uk/about.php?uid=5>

- Scott, J & Sinnamon, H. (2009). *Protecting American health from global shipping pollution establishing an emission control area in U.S. waters*. Retrieved June 17, 2009 from the World Wide Web: www.edf.org/documents/9466_ECA_report_March2009.pdf
- Shindell, D., G. Faluvegi, A. Lacis, J. Hansen, R. Ruedy, & E. Aguilar (2006). Role of tropospheric ozone increases in 20th-century climate change, *Journal Geophysics Research*, 111, 1 – 11
- Stopford, M. (2009). *Maritime Economics, 3rd edition*. New York: Routledge
- Streets, D.G., Carmichael, G.R., & Arndt, R.L. (1997). Sulphur dioxide emissions and sulphur deposition from international shipping in Asian waters. *Atmospheric Environment*, 31, pp. 1573-1582
- Streets, D.G., Guttikunda, S.K., Carmichael, G.R. (2000). The growing contribution of sulphur emissions from ships in Asian waters, 1988-1995. *Atmospheric Environment*, 34, 4425-4439
- Sweden. (2007). *Voluntary IMO Member State Audit Scheme. Audit of Sweden 22-29 January 2007. Audit Final Report*. Retrieved July 28, 2008, from Swedish Maritime Administration Web site: <http://www.shipadm.org/upload/Pdf-Gemensamma-Eng/AuditFinalReport.pdf>.
- Swedish Maritime Administration. (2004, September 10). *Information concerning new fairway dues*. Retrieved July 3, 2009 from the World Wide Web: <http://www.sjofartsverket.se/upload/2205/New%20fairway%20duesEng.pdf>
- Tanker Operator. (2006, January/February). Unravelling MARPOL Annex VI. *Tanker Operator*, 5 (1), p 20. Retrieved June 21, 2009 from the World Wide Web: <http://www.tankeroperator.com/janfeb06full.pdf>
- The European Environmental Bureau (EEB), The European Federation for Transport and Environment (T&E), Seas At Risk (SAR), The Swedish NGO Secretariat on Acid Rain. (2004). *Air pollution from ships*. Retrieved June 10, 2009 from the World Wide Web: [http://www.eeb.org/activities/air/ship-briefing-nov04-\(1\).pdf](http://www.eeb.org/activities/air/ship-briefing-nov04-(1).pdf)
- The International Convention for the Prevention of Pollution from Ships (MARPOL 73/78), IMO, (2006)
- Thia-Eng, C., Gorre, I.R.L., Ross, A., Bernad, S.R., Gervacio, B., & Ebarvia C. M. (2000). The Malacca Straits. *Marine Pollution Bulletin*, 41, 160-178
- Thomas, C.E. (2007). *Sulphur oxide and nitrogen oxides international and European legislation. A United Kingdom perspective*. Retrieved June 17, 2009 from the World Wide Web:

http://www.nmri.go.jp/main/cooperation/imo_iso/contents/IMO2007/airpolws/presentation/airpolws2.pdf

Tongzon, J.L. (2006). Whither the Malacca Straits? the rise of new hub ports in Asia. In G. G. Ong-Webb (Ed.). *Piracy, maritime terrorism and securing the Malacca Straits*. (pp. 201 - 210). Singapore: Institute of Southeast Asia Studies

Transport & Environmental Bulletin. (2009, May 18). *Environmental and health impact of shipping seriously underestimated*. Retrieved June 13, 2009 from the World Wide Web:

<http://www.transportenvironment.org/News/2009/5/Environmental-and-health-impact-of-shipping-seriously-underestimated/>

United Nation Conference on Trade and Development. (2008a). *Review of Maritime Transports 2008*. Geneva: Author

United Nation Conference on Trade and Development. (2008b). *Freight rates begin to fall for world merchant fleet*. Geneva: Author. Retrieved June, 5 2009 from the World Wide Web:

<http://www.unctad.org/Templates/webflyer.asp?docid=10755&intlItemID=1528&lang=1>

United Nation Conference on Trade and Development. (2009). The global economic crisis – linkages to shipping. *UNCTAD Transport Newsletter First Quarter 2009 (42)*. Geneva: Author

U.S. Census Bureau. (2009). *Statistical Abstract of the United States*. Washington: Author

Vlasblom. W.J. (2006). Dredging in the Dutch & Belgian Coastal Waters and The North Sea. In Eisma D (Ed), *Dredging in coastal waters (51-104)*. London, UK: Taylor & Francis

Walday, M. & Kroglund, T. (2002). *Europe's biodiversity - biogeographical regions and seas – The Baltic Sea*. Retrieved June, 5 2009 from the World Wide Web: http://www.eea.europa.eu/publications/report_2002_0524_154909/page141.html

Wang, C., Corbett, J.J. & Firestone, J. (2007). Modelling Energy Use and Emissions from North American Shipping: Application of the Ship Traffic, Energy, and Environment Model. *Environmental Science Technology*, 41, 3226-3232

Warne, K. (2008, October). Tuvalu is sinking. *Canadian Geographic Magazine*

Wärtsillä. (2006). *Low sulphur guidelines*. Helsinki: Author. Retrieved July 13, 2009 from the World Wide Web:

<http://www.cleanairactionplan.org/civica/filebank/blobdload.asp?BlobID=2323>

Winebrake JJ, Corbett JJ, Green EH, Lauer A, & Eyring V (2009). Mitigating the health impacts of pollution from oceangoing shipping: an assessment of low-sulphur fuel mandates. *Environmental Science Technology*, 43(13), 4776-82

Welsh, M. (2002). *Considerations for using low-sulphur fuel*. Retrieved July 20, 2009 from the World Wide Web:
http://www.wartsila.com/Wartsila/global/docs/en/ship_power/media_publications/technical_papers/sulzer/paper_lowsfuels_welsh.pdf

APPENDICES

Appendix A. Impact of NO_x, SO_x and PM emissions on the environment and human health

A.1. Eutrophication

NO_x, which is released from shipping activities, is one of the nutrient ingredients that is carried by winds and deposited on land and in water bodies. Eutrophication on land increases productivity of plants because of excessive nutrient availability. The effect of eutrophication on the forests is contrary to acidification. Unlike acidification on the forests, increase in the growth of plants brings benefit to the entire ecosystem. Perhaps, eutrophication in the water bodies is more harmful than on land.

Eutrophication might be called “nutrient pollution” since excessive nutrients stimulate intense algal blooms growth in water bodies such as lakes, seas and estuaries. Intense algal blooms are food sources for fish that can increase fish yields but later, abundant algal bloom will reduce sunlight penetration and oxygen in the bottom area, which leads to water quality and habitat degradation with an impact on fish and marine creature life. Notably, fish kill in water bodies is a common effect of eutrophication. For example Japan suffered a huge economic loss of approximately US\$ 60 million (death of 14.2 million yellowtails) from eutrophication caused by algal bloom (*C. antique*) in Harima-Nada in 1972 (Imai, Yamaguchi, Hori, 2006). In fact, the human being is the last victim of eutrophication because fish is the largest food source from water bodies. Low quality of fresh water supply for drinking and other utilities will impair health and shipping lanes might be blocked because of excessive algal blooms on water surface and depth deficiency.

A.2. Ground Level Ozone

Ground level ozone is when NO_x and hydrocarbon (HC) interact in the presence of sunlight. There is a growing grasp that NO_x and HC might attribute to climate change since ozone is a greenhouse gas. According to Intergovernmental Panel on Climate Change (IPCC) (2004), ground level ozone is the third most damaging

greenhouse gas. In the atmosphere, greenhouse gases will entrap heat of solar radiation rebounded from the earth while enabling most of incoming solar radiation to penetrate through the atmosphere; this leads to global warming which principally causes the spectre of climate change.

The phenomenon of climate change will provide challenges and offer opportunities. The threat posed by sea level rise possibly causes flooding of entire coastlines that will be completely inhabitable under worst scenario. The small Pacific State Island Tuvalu could suffer significant effects of 40 cm rise in sea level predicted by International Panel IPCC by the end of the twenty-first century (Warne, 2008). Consequently, a formal request was sent by Tuvalu to the Australian Government in 2000 regarding a possibility to accept refugees due to flooding risk induced by sea level rise that inevitably leads to loss of islands. Neighbouring countries in Pacific Ocean such as Kiribati, Samoa, and Micronesia relatively encounter same problems.

Conversely, global warming on the Arctic Sea is a contribution of ground level ozone (Shindell, Faluvegi, Lacis, Hansen, Ruedy & Aguilar, 2006) causing the melting of ice in the Arctic Sea, which is frankly beneficial. It will enable ships to intensively navigate via the Northern Sea Route and the Northwest Passage, which shortens the sea routes from Europe to Asia and other eastern destinations by around 4,000 nm and 2,500 nm respectively (Ehlers, 2008). Consequently, the frequency of vessel movement might grow significantly towards establishment of new ports along the shipping lane which creates potential economic advantages in surrounding areas. However, at the same time the Arctic environment will suffer more from ground level ozone. It is estimated that the amount could increase by a factor of two or three compared to present day levels (Quinn, Bates, Baum, Doubleday, Fiore, Flanner, Fridlind, Garrett, Koch, Menon, Shindell, Stohl, & Warren, 2008).

A.3. Acidification

SO_x and NO_x that are emitted from ships will react with other compounds in the atmosphere to form acid. Acid rain and fog fall to the earth leading to considerable negative implications. Acid rain could corrode buildings, sculptures and other constructions made of metal, limestone, marble and deteriorate paint on buildings

and cars. Corrosion significantly depreciates the value of buildings and requires maintenance costs. Unfortunately, the value of historical monuments and buildings can never be replaced by sophisticated renovation. For example, an El Tajin archaeological zone in Veracruz, Mexico, where 70% of the components of the building were made of limestone, was effectively dissolved by acid rain (Bravo, Soto, Sosa, Sánchez, Alarcón, Kahl, & Ruíz, 2006). The proximity of El Tajin to pollution sources is the main cause. El Tajin is located on the coastal area of the Gulf of Mexico, which is surrounded by polluters such as industries, land transport and shipping. Indeed, ships were responsible for the increase in acidification accounting for 3%-10% in certain coastal areas (Edressen et al, 2003) which might accelerate the devastation process.

A.4. Human health

Particulate matter (PM_{2.5}) is linked to premature mortalities due to heart attacks, permanent respiratory damage and lung cancer. Corbet et al (2007) estimated that 3% to 8% of global mortalities related to PM_{2.5} emissions from shipping lead to 64,000 premature deaths in 2002 because of cardiopulmonary disease and lung cancer. According to Corbet et al, this figure might increase by 40% in 2012 under current regulation following rapid growth in maritime freight. Clean Air Task Force (CATF) estimated cost related to premature death to more than \$330 billion per year and will rise to more than \$460 billion in 2012 (New Report Predicts Substantial Death Toll from Under-regulated Shipping Emissions, 2007). In particular, Europe, East Asia and South Asia coastlines are the most affected mortality areas attributable to PM concentration related to maritime transport.

Exposure to PM_{2.5} concentration from ships causes respiratory diseases, namely cardiopulmonary and lung cancer. Recent research elaborated the number of global premature mortalities related PM_{2.5} into cardiopulmonary and lung cancer with the use of two inventory databases: AMVER and COADS. AMVER collects world fleet numbers but COADS only count world passengers and cargo ships. The mortality projection of cardiopulmonary in 2012 is approximately 83,500 deaths (AMVER) and 76,700 deaths (ICOADS), while lung cancer is around 7100 deaths (AMVER) and 7000 deaths (ICOADS) (Winebrake, Corbett, Green, Lauer & Eyring, 2009). This

estimation employed “no action” scenario, which means that there was no effort from international community to reduce fuel sulphur content less than 2.70 %.

Appendix B. Special areas under MARPOL

Adoption, entry into force & date of taking effect of Special Areas			
Special Areas	Adopted #	Date of Entry into Force	In Effect From
Annex I: Oil			
Mediterranean Sea	2 Nov 1973	2 Oct 1983	2 Oct 1983
Baltic Sea	2 Nov 1973	2 Oct 1983	2 Oct 1983
Black Sea	2 Nov 1973	2 Oct 1983	2 Oct 1983
Red Sea	2 Nov 1973	2 Oct 1983	*
"Gulfs" area	2 Nov 1973	2 Oct 1983	1 Aug 2008
Gulf of Aden	1 Dec 1987	1 Apr 1989	*
Antarctic area	16 Nov 1990	17 Mar 1992	17 Mar 1992
North West European Waters	25 Sept 1997	1 Feb 1999	1 Aug 1999
Oman area of the Arabian Sea	15 Oct 2004	1 Jan 2007	*
Southern South African waters	13 Oct 2006	1 Mar 2008	1 Aug 2008
Annex II: Noxious Liquid Substances			
Antarctic area	30 Oct 1992	1 Jul 1994	1 Jul 1994
Annex V: Garbage			
Mediterranean Sea	2 Nov 1973	31 Dec 1988	1 May 2009
Baltic Sea	2 Nov 1973	31 Dec 1988	1 Oct 1989
Black Sea	2 Nov 1973	31 Dec 1988	*
Red Sea	2 Nov 1973	31 Dec 1988	*
"Gulfs" area	2 Nov 1973	31 Dec 1988	1 Aug 2008
North Sea	17 Oct 1989	18 Feb 1991	18 Feb 1991
Antarctic area (south of latitude 60 degrees south)	16 Nov 1990	17 Mar 1992	17 Mar 1992
Wider Caribbean region including the Gulf of Mexico and the Caribbean Sea	4 July 1991	4 Apr 1993	*
Annex VI: Prevention of air pollution by ships (SOx Emission Control Areas)			
Baltic Sea	26 Sept 1997	19 May 2005	19 May 2006
North Sea	22 July 2005	22 Nov 2006	22 Nov 2007

Status of multilateral conventions and instruments in respect of which the international maritime organization or its secretary general perform depositary or other functions as at 31 December 2002

* The Special Area requirements for these areas have not taken effect because of lack of notifications from MARPOL Parties whose coastlines border the relevant special areas on the existence of adequate reception facilities (regulations 38.6 of MARPOL Annex I and 5(4) of MARPOL Annex V).

Source: IMO. (2009h). Special Areas under MARPOL. Retrieved August 10, 2009 from the World Wide Web: http://www.imo.org/Environment/mainframe.asp?topic_id=760

Appendix C. European Union Regulations – Application in EU Member States

Timeline	Regulation Reference	Enforcement Area	Impacted Operator	Detail of Restriction
July 2000	1999/32/EC	EU Ports	All Vessels	Max 0.20% m/m sulphur content of Marine Gas Oil
11 August 2006	2005/33EC	EU Ports	Scheduled Passenger Vessels (>12 passengers)	Max 1.50% m/m sulphur content of bunker fuel
11 August 2006	2005/33EC	Baltic Sea (SECA)	All Vessels	Max 1.50% m/m sulphur content of bunker fuel
16 August 2006	1999/32/EC 2005/33EC	EU Ports	Suppliers	No sale of > 1.50% sulphur content of Marine Diesel Oil
11 August 2007	2005/33EC	North Sea (SECA)	All Vessels	Max 1.50% m/m sulphur content of bunker fuel
1 January 2008	1999/32/EC 2005/33EC	Eu Ports	All Vessels	Max 0.10% m/m sulphur content Marine Gas Oil
1 Jan 2010	2005/33EC	EU Ports	All Vessels at berth and inland waterways	Max 0.10% sulphur content of bunker fuel
1 Jan 2010	1999/32/EC 2005/33EC	EU Ports	Suppliers	No sale of >0.10% sulphur content of Marine Gas Oil

Source: Krystallon. (2009). *Ship emissions regulations overview IMO and local directives*. Retrieved July 10, 2009 from the World Wide Web <http://www.krystallon.com/emissions-monitoring.htm>

Appendix D. CARB Directive, California Air Resources Board – Application in California, US

Timeline	Regulation Reference	Enforcement Area	Impacted Operator	Detail of Restriction
1st January 2007	Ocean-going vessel auxiliary engine and diesel-electric engines	California Waters (24 nautical miles out)	All Vessels	1.00% max sulphur in Marine Gas Oil (MGO) and 0.5% max sulphur in Marine Diesel Oil (MDO) – Auxiliary Engines
2010	Ocean-going vessel auxiliary engine and diesel-electric engines	California Waters (24 nautical miles out)	All Vessels	0.10% max sulphur in Marine Gas Oil (MGO) and Marine Diesel Oil (MDO) – Auxiliary Engines
2010 - 2015	Main Engines	California Waters (24 nautical miles out)	All Vessels	Sulphur content limit lowered for fuels in main engines SECA establishment

Appendix E. Transport and Environment Canada – Application in CANADA

Timeline	Regulation Reference	Enforcement Area	Impacted Operator	Detail of Restriction
1st October 2007	Sulphur in Diesel Fuel Regulations	Canada	Supplier	Sulphur limit of 0.05% (50 ppm) in Marine Diesel Oil
1st June 2012	Sulphur in Diesel Fuel Regulations	Canada	Supplier	Sulphur limit of 0.0015% (15 ppm) in Marine Diesel Oil
Early 2007	Canada Shipping Act, 2001 Regulations for the Prevention of Pollution from Ships and for Dangerous Chemicals	Canadian waters and within 1 mile of land	All Vessels	Fuel-burning installation may emit black smoke only to the “density” levels specified by the Act and based on the Dept of Transport Smoke Chart

Source: Krystallon. (2009). *Ship emissions regulations overview IMO and local directives*. Retrieved July 10, 2009 from the World Wide Web <http://www.krystallon.com/emissions-monitoring.htm>

Appendix F. NOx emission requirement: Tier I, Tier II and Tier III

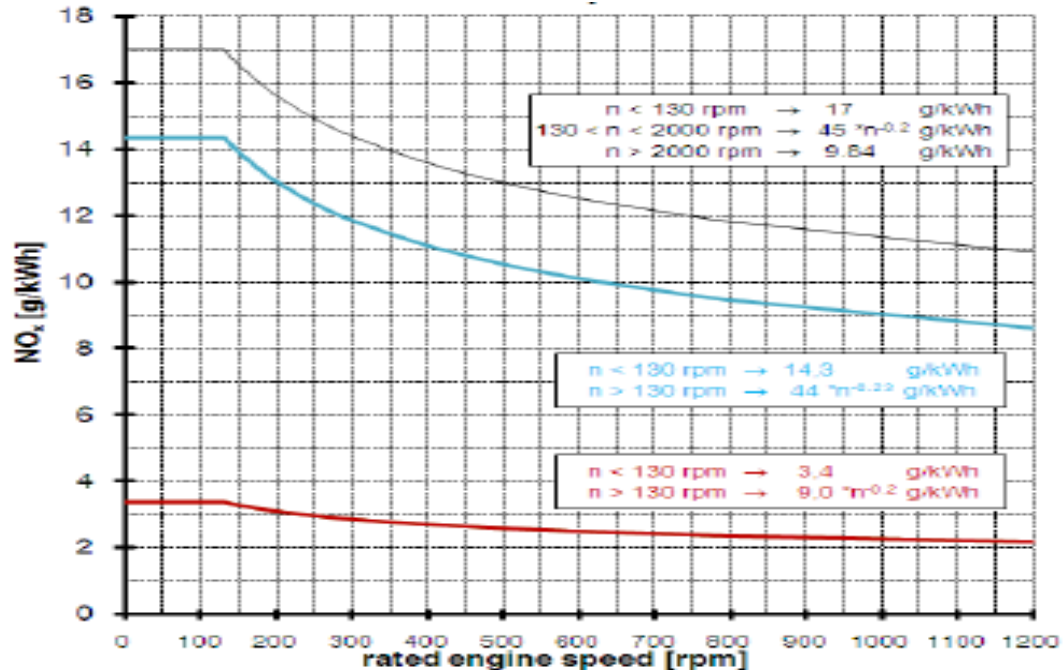

Tier I, Tier II and Tier III Graphic

Tier I

I. Subject to regulation 3 of this Annex, the operation of a marine diesel engine which is installed on a ship constructed on or after 1 January 2000 and prior to 1 January 2011 is prohibited, except when the emission of nitrogen oxides (calculated as the total weighted emission of NO₂) from the engine is within the following limits, where n = rated engine speed (crankshaft revolutions per minute):

- I.1. 17.0 g/kWh when n is less than 130 rpm;
- I.2. $45 \cdot n^{-0.2}$ g/kWh when n is 130 or more but less than 2,000 rpm;
- I.3. 9.8 g/kWh when n is 2,000 rpm or more.

Tier II

II. Subject to regulation 3 of this Annex, the operation of a marine diesel engine which is installed on a ship constructed on or after 1 January 2011 is prohibited,

except when the emission of nitrogen oxides (calculated as the total weighted emission of NO₂) from the engine is within the following limits, where n = rated engine speed (crankshaft revolutions per minute):

- II.1. 14.4 g/kWh when n is less than 130 rpm;
- II.2. $44 \cdot n^{(-0.23)}$ g/kWh when n is 130 or more but less than 2,000 rpm;
- II.3. 7.7 g/kWh when n is 2,000 rpm or more.

Tier III

- III. Subject to regulation 3 of this Annex, the operation of a marine diesel engine which is installed on a ship constructed on or after 1 January 2016:
 - III.1. is prohibited except when the emission of nitrogen oxides (calculated as the total weighted emission of NO₂) from the engine is within the following limits, where
n = rated engine speed (crankshaft revolutions per minute):
 - III.2. 3.4 g/kWh when n is less than 130 rpm;
 - III.3. $9 \cdot n^{(-0.2)}$ g/kWh when n is 130 or more but less than 2,000 rpm; and
 - III.4. 2.0 g/kWh when n is 2,000 rpm or more;
 - III.5. is subject to the standards set forth in subparagraph 5.1.1 of this paragraph when the ship is operating in an Emission Control Area designated under paragraph 6 of this regulation; and
 - III.6. is subject to the standards set forth in paragraph 4 of this regulation when the ship is operating outside of an Emission Control Area designated under paragraph 6 of this regulation.

Source: International Maritime Organization. (2008d, October 17). Report of the Marine Environment Protection Committee on its fifty-eighth session (MEPC 58/23/Add.1). London: Author.

Appendix G. ECA documentations related to low sulphur fuel oil method

In compliance with Emission Control Area requirement, ship operators are obliged to record information related to control of SO_x emissions during ship operation. The following documentations must be kept onboard to be readily available at inspection by Administration and PSC officers.

- Bunker Delivery Note is an essential document to prove that 1.50% low sulphur fuel oil has been bunkered and consumed by ships as required by regulation 18. The figure of sulphur content in the fuel oil on BDN must be an accurate statement. Previously, the standard of fuel content in fuel oil was decided in one decimal digit namely 1.5% (ECA) and 4.5% (global sulphur cap). Nowadays, the IMO unified interpretation requires two decimal digits namely 1.50% and 4.50%. Consequently, a sample test result in 1.51% sulphur content will be considered as a violation of the regulation.
- Low and high sulphur fuel oil shall be located in different tanks especially for ships operating within and outside ECA. This information must be recorded in the Oil Record Book.
- The process change over from high sulphur fuel oil to low sulphur fuel oil prior to entering ECA shall be documented in a log book as prescribed in regulation 14.6. This information includes date, time and position when a change over process has been completed.
- The same information shall be recorded in the log book when ships leave ECA. The change over back to higher sulphur oil shall be carried out after leaving ECA.
- The adequate quantity of low sulphur fuel within ECA shall be entered in the log book. Consequently, the personnel who is responsible for purchasing bunker must ensure that adequate fuel quantity is available prior to entering a ECA.