

August 2014

# Optimal DC Power Distribution System Design for Data Center with Efficiency Improvement

Xuechao Wang

*University of Wisconsin-Milwaukee*

Follow this and additional works at: <https://dc.uwm.edu/etd>



Part of the [Electrical and Electronics Commons](#)

---

## Recommended Citation

Wang, Xuechao, "Optimal DC Power Distribution System Design for Data Center with Efficiency Improvement" (2014). *Theses and Dissertations*. 547.

<https://dc.uwm.edu/etd/547>

This Thesis is brought to you for free and open access by UWM Digital Commons. It has been accepted for inclusion in Theses and Dissertations by an authorized administrator of UWM Digital Commons. For more information, please contact [open-access@uwm.edu](mailto:open-access@uwm.edu).

OPTIMAL DC POWER DISTRIBUTION SYSTEM DESIGN FOR DATA CENTER  
WITH EFFICIENCY IMPROVEMENT

by

Xuechao Wang

A Thesis Submitted in  
Partial Fulfillment of the  
Requirements for the Degree of

Master of Science  
in Engineering

at

The University of Wisconsin-Milwaukee

August 2014

## ABSTRACT

### OPTIMAL DC POWER DISTRIBUTION SYSTEM DESIGN FOR DATA CENTER WITH EFFICIENCY IMPROVEMENT

by

Xuechao Wang

The University of Wisconsin-Milwaukee, 2014  
Under the Supervision of Professor Adel Nasiri

Data Center Power Distribution design is very popular today focusing on improved energy efficiency and reduced operating cost. Conventionally data centers use low efficiency electrical power distribution systems with large AC power transformers, high power losses, and AC UPS and PDU power conversions. Most IT servers utilize low voltage level (12V or 48V) as the power source, which requires a step-down transformer and AC to DC rectifiers in every PDU. The “Proposed 380V DC Power Distribution System” promises to deliver high transmission efficiency and low power component cost.

This is a comprehensive design including data center physical architecture and equipment selection, centralized rectifier design, simulation and analysis, power loss analysis, and power requirement and system efficiency calculations.

The core technical contribution is the design and simulation of a Buck-type current source rectifier using efficiency modeling analysis. This special converter is applied to data center power system to replace large scale AC transformers and distributed rectifiers. Related power and efficiency calculations aim to verify the viability, applicability, and practicality of this system design and to minimize power losses.

© Copyright by Xuechao Wang, 2014  
All Rights Reserved

# TABLE OF CONTENTS

Chapter I Introduction.....	1
1.1 Data Center Power System .....	1
1.2 AC Power Distribution System.....	3
1.3 DC Power Distribution System.....	4
1.4 Energy Consumption Comparison .....	5
1.5 Article Layout .....	6
Chapter II Power Distribution Architecture.....	8
2.1 Data Center Power Distribution Equipment .....	8
2.2 Data Center Power Distribution Approaches.....	12
2.3 Data Center Power Consumption Flow .....	14
2.4 The Schematic of Power Distribution.....	16
2.5 Optimized Date Center DC Distribution Structure.....	20
Chapter III Power Conversion .....	22
3.1 Current Source Rectifier .....	23
3.2 Simulation Models.....	25
3.3 Control Strategy and Results .....	29
3.4 Voltage Source Rectifier and Buck Converters.....	34
3.5 DC Energy Storage .....	37
Chapter IV Efficiency Modeling of Converter .....	39
4.1 Calculation of Power Losses.....	39
4.2 Effectiveness of Variable Loads.....	43
Chapter V System Power and Efficiency Calculation .....	48
5.1 Calculating Total Power Requirements.....	48
5.2 Calculation of Efficiency (PUE).....	51
5.3 Expected Energy Savings .....	54
5.4 Opportunities for Additional Energy and Efficiency Savings .....	56
Chapter VI Conclusion .....	59
References.....	60

## LIST OF FIGURES

Figure 1: One-line diagram of typical AC Power system .....	3
Figure 2: One-line diagram of DC Power system.....	4
Figure 3: Difference in losses of each section in typical AC Power system.....	5
Figure 4: Difference in losses of UPS system in typical AC and DC Power system .....	5
Figure 5: Difference in losses of AC and DC in LBNL and EPRI .....	6
Figure 6: Block diagram of AC Distribution System in a typical data center .....	9
Figure 7 (a): One-line diagram of MV switchgear.....	10
Figure 7 (b): One-line diagram of LV switchgear.....	10
Figure 8: Eaton Floor Based Power Distribution Unit.....	11
Figure 9: Data Center Power Flow .....	15
Figure 10: Traditional AC Power System Schematic .....	17
Figure 11: AC Distribution with one DC bus Schematic.....	18
Figure 12: Proposed 380V DC Power Distribution System .....	19
Figure 13: Balanced Tree.....	21
Figure 14: Detailed view of Typical AC Power System (top) and Proposed DC Power System (bottom).....	23
Figure 15: Conversion circuit schematic. ....	25
Figure 16: The screen capture of the converter system simulation module with current and voltage PI loop PWM control .....	26
Figure 17: The screen capture of the converter system simulation module DQ PWM control .....	27
Figure 18: The diagram of the PI PWM control .....	29

Figure 19: The scope waveforms of input AC voltage and current; output DC voltage and current. ....	30
Figure 20: A-B-C stationary frame to D-Q rotating frame .....	31
Figure 21: The schematic with parameter settings and the subsystem of “PLL&Measurements” in the DQ PWM control in MATLAB/SIMULINK Model .....	32
Figure 22: The scope waveforms of input AC voltage and current; output DC voltage and current and PWM signal .....	33
Figure 23: The circuit schematic of Voltage Source Rectifier .....	34
Figure 24: The scope waveforms of input AC voltage and current; output DC voltage and current .....	35
Figure 25: the circuit schematic of Buck Converter in MATLAB/SIMULINK.....	36
Figure 26: the scope waveforms of output voltage and current for 48V Level and 12V Level. ....	37
Figure 27: Standby AC UPS System diagram. ....	37
Figure 28: New Designed Standby DC UPS System diagram .....	38
Figure 29: Total semiconductor power losses depending on the numbers of parallel switches and diodes.....	42
Figure 30: Output DC Voltage and Current under variable loads.....	45
Figure 31: Typical efficiency of a UPS as a function of IT loads.....	46
Figure 32: Data Center Efficiency Calculator online tool .....	53
Figure 33: Data Center AC vs DC Calculator online tool. ....	55



## LIST OF TABLES

Table 1: The category of three power distribution approaches. ....	12
Table 2: The energy consumption percentage of different equipment.....	16
Table 3: Parameter list of the PI PWM Control simulation module. ....	28
Table 4: Parameter list of the DQ PWM Control simulation module.....	29
Table 5: Parameter list of each PI PWM Controllers.....	30
Table 6: Power Losses Values of semiconductors. ....	41
Table 7: Data Center Power Requirement and Power Capacity estimated calculation sheet. .....	51

# Chapter I Introduction

With the development of Internet business, digital information management has become fundamental to maintaining the common operation of academic, government and communicational systems. Data centers contain primarily electronic facilities for data processing, storage, and communications networking [1]. Besides the well-known “information technology” (IT) equipment, data centers have engineered electrical power distribution system, and conversion and backup devices to maintain a reliable and high-efficiency electrical energy supply for the IT equipment, lighting and air conditioner as well [1].

## 1.1 Data Center Power System

In a typical data center room, many rows of IT equipment racks are filled in parallel order. Usually one row of equipment rack is an individual power distribution unit, which contains main server, energy storage and a power conversion bays. Uninterruptible Power Supply (UPS), consisting of batteries and power conversions systems, acts as energy backup to prevent servers from experiencing power disruptions [1]. Power conversion happens in Power Distribution Unit (PDU), where high voltage AC input power is transferred to low voltage DC for servers’ power. The size of the UPS system depends on the electricity consumption ratings. Large energy consumption sites and highly important

data centers normally have a UPS for each IT equipment racks; otherwise the data center is vulnerable because there is only one UPS system for the whole data center.

Two main input buses provide 480V/277V three phase four wire AC power to UPS units first before reaching the IT equipment rack [2]. To charge the batteries, electricity is converted from AC to DC when discharging, DC is inverted to AC. The PDU has step-down transformers to reduce voltage to usable levels and also convert AC to DC for IT loads. To proper continued operation of servers and power supply equipment, the more than 50% of heat generated is unnecessary and could be removed. Computer Room Air Conditioning (CRAC) system usually provides the data center cooling is served by the input bus.

Power distribution in data center can be accomplished by AC or DC power. AC power distribution systems are widely applied in main bus installation of voltage of 120V, 208V or 240V [2]. However, the number of distributed converters reduced the energy efficiency with a high device investment. Engineers and manufacturers propose replacing AC Power Distribution Systems with DC Power Distribution System for high-efficiency centralized power conversion equipment. With the development of DC distribution technology, voltages of 300V, 380V, 400V and 575V have been proposed in various “forums”.

## 1.2 AC Power Distribution System

The traditional AC power distribution system for data centers is 480V/277V three phase providing power to a UPS, then a PDU converts to 208V/120V for single phase branch circuits utilized by IT equipment [3]. Figure 1 is the one-line diagram showing this configuration.

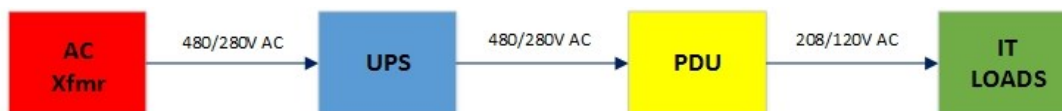

Figure 1. One-line diagram of typical AC Power system

Based on the research of paper [4], at the baseline operating load- 50% load, overall efficiency is around 89.30% which is lower than the DC overall efficiency 90.35%. This efficiency was calculated by for three power path segments: UPS, Distribution wiring and IT Equipment Power Supply. The 1.05% efficiency difference between the DC and AC system because the IT power supply has higher efficiency. Besides UPS and wiring conduction losses, the AC system has a large number of distributed power electronics converters located in PDUs creating power loss and wasted heat.

Advantages of conventional AC distribution are worldwide compatibility and applicability for a wide voltage range.

### 1.3 DC Power Distribution System

As described in section 1.2, the DC power distribution system has higher efficiency because it has a centralized rectifier feeding a 380V DC bus, shown in the one-line diagram Figure 2. The IT loads utilize 48V or lower levels from simple Buck converters.



Figure 2. One-line diagram of DC Power system

According to [5], transformers caused up to 6% of total power losses (see Figure 3). These studies assumed that there are no AC power transformers in the DC distribution system. To authentically have a 380V DC bus and eliminate the transformers, I proposed the Current Source Buck-type Rectifier (CSBR). This converter can transfer AC to DC and lower the DC voltage level to usable voltages. Any power distribution should provide isolation between the high voltage supply and logic circuits. This isolation is achieved within the power supply conversion instead of transformers found in both traditional AC and DC power systems. Details of CSBR will be discussed in Chapter III.

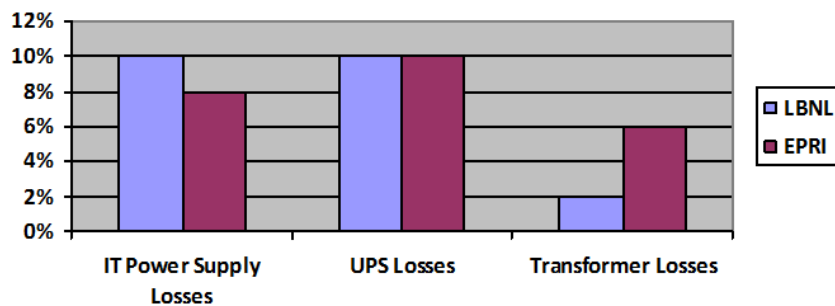

Figure 3. Difference in losses of each section in typical AC Power system. Data source: [5].

Since the system has a 380V DC bus, the energy storage model can be simplified to charging DC batteries directly through DC breakers. Figure 4 shows the UPS power loss data in AC and DC systems from LBNL and EPRI. The UPS efficiency data is based on system measurements which include power conversion losses.

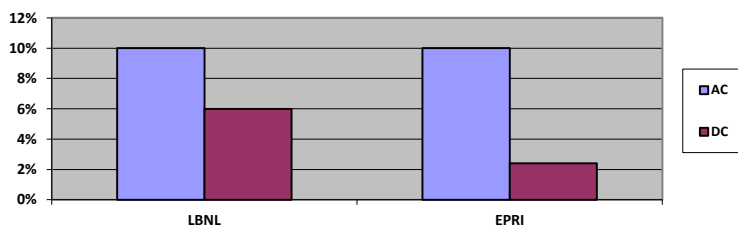

Figure 4. Difference in losses of UPS system in typical AC and DC Power system. Data source: [5].

## 1.4 Energy Consumption Comparison

In most existing AC data centers, power is delivered to the IT equipment as AC, which is converted to DC in the IT device power supply. In the proposed system, power is converted to DC closer to the utility supply and is distributed to load as DC. LBNL and EPRI conducted studies using both measurements and calculations to compare the projected power losses and energy efficiency differences between AC and DC distribution shown Figure 5. The calculated data differs from the experimental data due to assumptions about load.

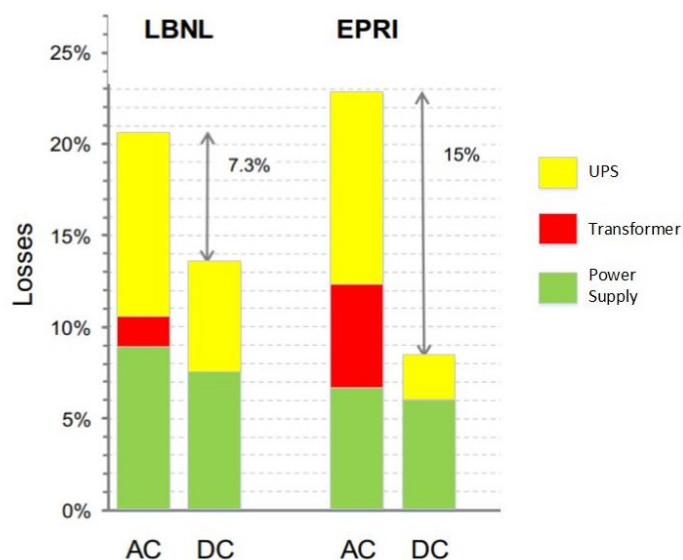

Figure 5. Difference in losses of AC and DC in LBNL and EPRI. Data source: [5].

Where conversion happens, power losses occur. Power supplies and UPSs in either the AC or DC systems are responsible for the majority of losses. Usually, the power factor correct in modern AC power supply system which is used to control the input current and eliminating harmonics, can be removed from DC operation to get 1% efficiency promotion [5]. What is more, the Proposed DC Power System charges the battery directly with one less stage of conversion in the DC system, which can bring lower power losses in UPS than the result shown in the Fig.5 above. A detailed calculation will be described in Chapter III.

## 1.5 Article Layout

This paper is organized as follows: Chapter II will focus on the DC Power Distribution

Architecture, including the power supply equipment, distribution schematic and power flow. The power conversion model, control strategy analysis, and DC UPS formulation is provided in Chapter III. Based on the simulation model, Chapter IV provides the converter power losses calculations. Chapter V presents the system efficiency modeling through total power requirements and PUE calculations, and also the expected and potential energy cost savings. Chapter V also presents opportunities for additional efficiency improvement by applying renewable energy to data center power supply systems. Concluding remarks are given in Chapter VI.



## **Chapter II Power Distribution Architecture**

Significant improvements in efficiency, power density and configurability have been achieved in data center with the development of electrical distribution equipment [6]. The techniques of transformer-based power supply are shown to be obsolete [7]. This chapter explains the physical equipment as well as the power flow and system schematic.

### **2.1 Data Center Power Distribution Equipment**

In a data center electrical power distribution system, the equipment usually contains high voltage, medium voltage, and low voltage; switch gear, switchboards, panel boards, and power distribution units, etc. [8]. Figure 6 is a simple diagram example of an AC distribution system architecture.

The diagram illustrates two AC voltage levels in the system, medium and low voltage level. The utility grid supplies the medium voltage which is stepped down to low voltage by a three phase transformer. The reactive compensation devices are normally installed at medium voltage level. The low AC voltage bus distributes electrical power to the different loads such as IT equipment, lighting and cooling systems. PDU converts AC to DC and also lower the voltage to server's utilization level, 5V, 12V or 24V, etc. Based on the data center power rating, multi-megawatt data centers can specify additional

“rPDU” located in the server rack to share the operation in order to avoid the size of main PDU when it becomes too big.

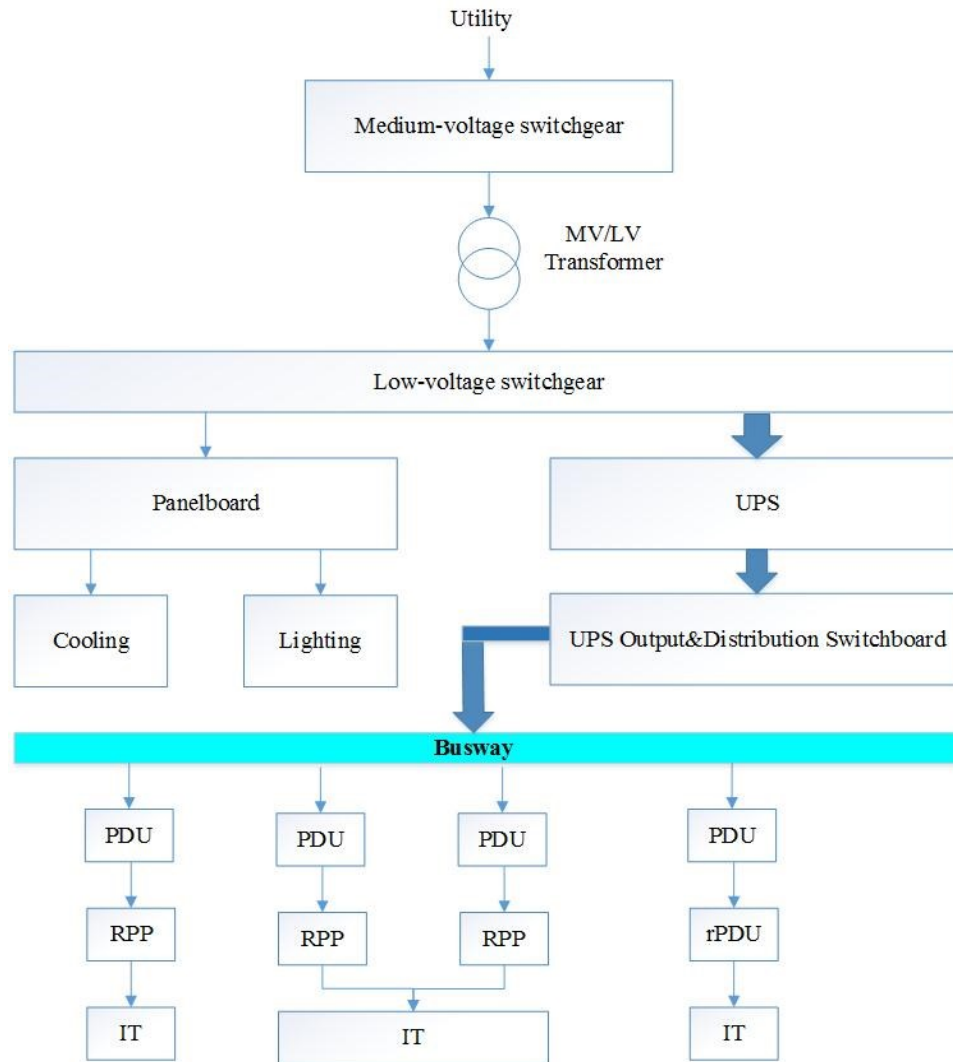

Figure 6. Block diagram of AC Distribution System in a typical data center [8].

Medium-voltage (MV) switchgear is generally used in large –capacity data centers with more than 1 MW of loads. The gear is fed directly from the utility grid, may contains breakers, meters, contactors and related electrical devices. Fig.7 (a) is the one-line

diagram of a MV switchgear line-up. For the less than 1 MV loads in data center, a low-voltage switchgear or a switchboard is installed and the incoming feed is connected with the secondary of MV transformer. Per the one-line diagram in Fig7 (b), the system has power control center and motor control center for the cooling pump and harmonic filter or power factor correction filter.

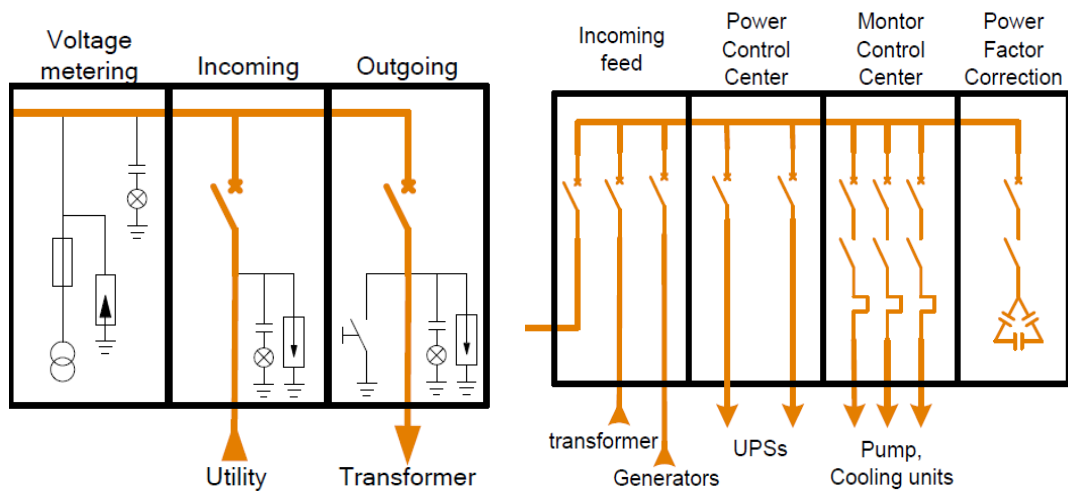

Figure 7. (a) One-line diagram of MV switchgear [8]. (b) One-line diagram of LV switchgear [8]

Per the discussion in the previous Chapter, PDU is the critical equipment for distribution, control and monitoring the electrical power from UPS to IT racks. In AC Power systems, PDU with a power transformer are mainly used to step down 480VAC to 120/208VAC and the power rated from 50kW to 500kW [8]. A typical PDU cabinet has main circuit breaker, branch circuit panels, cables, surge arrestor, monitoring and communication modules. Fig 8 shows the Eaton Power Distribution Unit. To deliver effective power management and monitoring, the Eaton PDU incorporates the Eaton Energy Management

System, optimizing both utilization and availability down to the branch circuit level [9].



Figure 8. Eaton Floor Based Power Distribution Unit. Source: [9].

Features of the advanced PDU based on the example from [9] :

- Integrated isolation, comprehensive monitoring, and a wide array of connectivity options [9].
- Unparalleled ease of use through front-access only design, top and bottom cable access, and spacious wire-ways [9].

Bus way approach is designed for power distribution from LV switchgear to PDU, and it could be mounted as overhead or underground. The existing design for AC power distribution set the over-current protection devices on the bus to protect the system. Panel board is widely used to distribute the power to non-IT load, like lighting, cooling and office utilization. To reduce the power ratings and increase the efficiency of the power system, some large data centers have Rack PDUs (rPDUs) which are connected directly

with upstream and distributed power to IT load at different loads.

## 2.2 Data Center Power Distribution Approaches

With the increase of power density and quantity of IT devices in data centers, the power distribution approaches definitely challenged the architecture. According to the research done before, a summary of three power distribution approaches is discussed in this section [6]. Each of the PDU and the Modular distribution can be subdivided into two different solutions. Table 1 is the definition of the three approaches to distributing power to IT racks.

Panelboard Distribution	Traditional PDU Distribution	Modular Distribution
	Field-wired PDU	Floor-mount Distribution
	Factory-configured PDU	Busway Distribution

Table1 the category of three power distribution approaches.

Panelboard is rated from 1.5KVA to 75KVA [6], specially designed for small load capacity installations and low capital cost. Since this approach will not be used in the proposed DC Power Distribution system, it won't be introduced anymore.

In a large load capacity data center, power is distributed to multiple PDUs rated from 50kVA to 500kVA [6]. They are fed directly from centralized circuit breaker and UPS,

and placed along the perimeter of the space. Each IT rack enclosure uses certain branch circuits which are placed under-floor or over-head cables. Two main categories of traditional PDU systems:

- Field-wired means that the cables go through cable trays or rigid conduit underneath the floor or overhead [6].
- Factory-configured using pre-installed overhead cables assemblies to the IT rack [6].

Field-wired PDU distribution approach is always used when floor space is limited and IT equipment are not likely to be changed frequently. Another advantage for this method is lower capital cost than other factory-configured PDU and Modular Distribution. When a data center plans to scale or re-layout its IT device in the future, Factory-configured PDU would be the best choice.

Comparing the traditional PDU distributions approaches, the advanced modular power distribution system is more efficient and flexible, also causing a higher capital cost than other approaches. There are two modular systems available:

- Busway: Through overhead or underfloor using plug-in units [6].
- Floor-mount: Using cables for branch circuits, distributing overhead in cable trays to IT server enclosure with pre-terminated modules that plug into finger-safe back-plane of PDU [6].

The Busway system is usually applied in the data center which has constrained floor space and well defined IT layout in large facilities. The IT load running value should be constant because adding new cables is difficult once the busway installation is done. Floor-mount modular power distribution is designed for the data center without certain power loads and requiring flexible distribution. This solution works for retrofitting existing data centers too which required additional load capacity.

There was a comparison of these five approaches from the perspectives of reliability, cost, and agility [6]. The modular distribution system is manufactory pre-assembly plug in units, meaning no exposure to live electrical wiring, thus highly increased reliability and safety. However, the capital and operating cost is 25% to 50% higher. Generally speaking, Modular Distribution approaches are more flexible, more manageable, more reliable and highly efficiency improved for the high-density data centers today [6].

### **2.3 Data Center Power Consumption Flow**

In the previous Chapter, the power consumption flow from initial high voltage input to IT loads has been discussed, but the actual measurement and quantitative comparison didn't show up until this section. This section provides detailed data center power flow and definition of Power Usage Effectiveness.

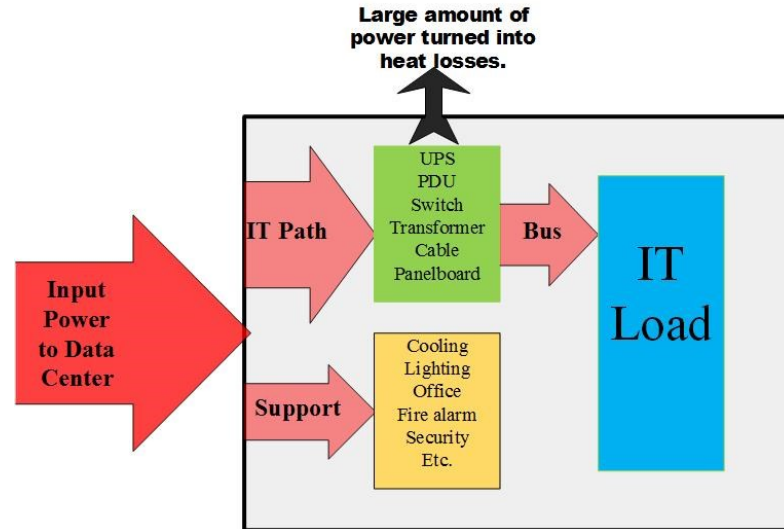

Figure 9. Data Center Power Flow

In a traditional AC Power Distribution Data Center, more than half of electrical energy consumed by the “support equipment”, including power supply devices, cooling system and lighting. Therefore only less than 50% of electricity is purchased by “useful” IT load, the other is called “support power” or “waste power” [10]. Fig. 9 shows the power flow of a typical AC Power System Data Center. Power path generates large amount of heat, taking away by cooling system which gains electricity from power supply system with considerable power losses. The proposed DC Power system is trying to remove the large scale transformer which generating the most heat and replacing the distributed converters by centralized one with lower power losses.

In the academic “research realm” of data center, usually efficiency is measured as the ratio of total facility electrical power to IT consumed power, and this metric is called



Power Usage Effectiveness (PUE) [10]:

**Data Center Efficiency (PUE) = Total Facility Power / IT Equipment Power**

A PUE equals 1 means no power losses during delivering, equivalent to a 100% efficient data center. The higher the PUE number, the lower the efficiency of whole system.

Electrical Equipment	IT Equipment (PUE=2.13)	Chiller	Humidifier	CRAC CRAH	PDU UPS	Lighting &Others
Energy consumption percentage	47%	23%	3%	15%	9%	3%

Table 2 The energy consumption percentage of different equipment. Data source [11]

Data of Table 2 is based on a typical data center operating at 30%load, showing that only half of the energy goes into the “Useful” devices in a typical high density data center with PUE equals 2.13 [11]. Obviously, another half is consumed by data center physical infrastructure (DCPI), intending to all the support equipment. These are considered as inefficiency and to dramatically reduce this inefficiency is the main purpose of recent research on data center.

## 2.4 The Schematic of Power Distribution

Through the schematic figures of power distribution system, the wiring diagram becomes very intuitive and convenience for design and analysis. This section gives the Traditional AC Power Distribution Solution Schematic and the Proposed DC Power Distribution

## Solution Schematic.

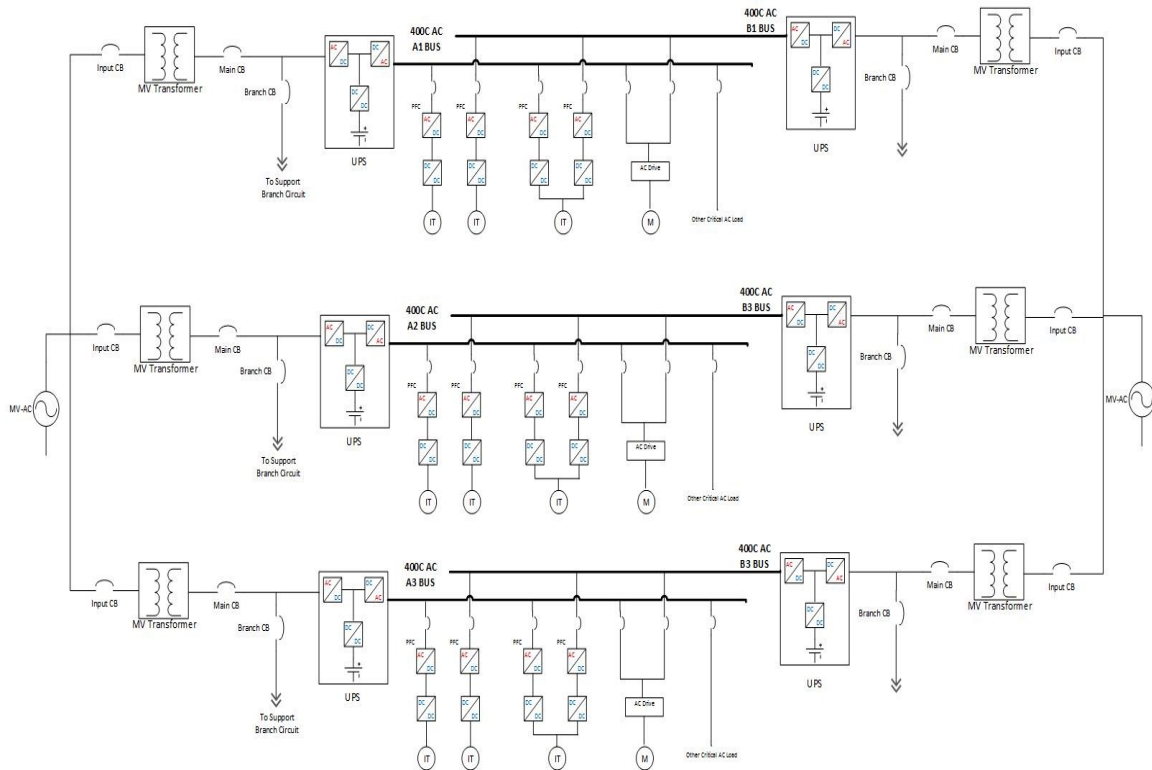

Figure 10 Traditional AC Power System Schematic [5]

Figure 10 is the traditional AC Power System Solution. One main and one backup input from the grid with media voltage. Three phase step down transformer reduced the voltage to 400Volts AC. Then one branch sends power to non-vital loads such as lighting and office regular devices. UPS system storage the energy before it arrived at the IT Rack. The 400V AC bus sends the power to each PDU for power conversion to usable voltage levels for servers. Some non-IT vital loads are connecting to the bus, like firing alarm and security, which also needs the backup power supply from UPS when the input is cut. The whole system efficiency is around 85% [5].

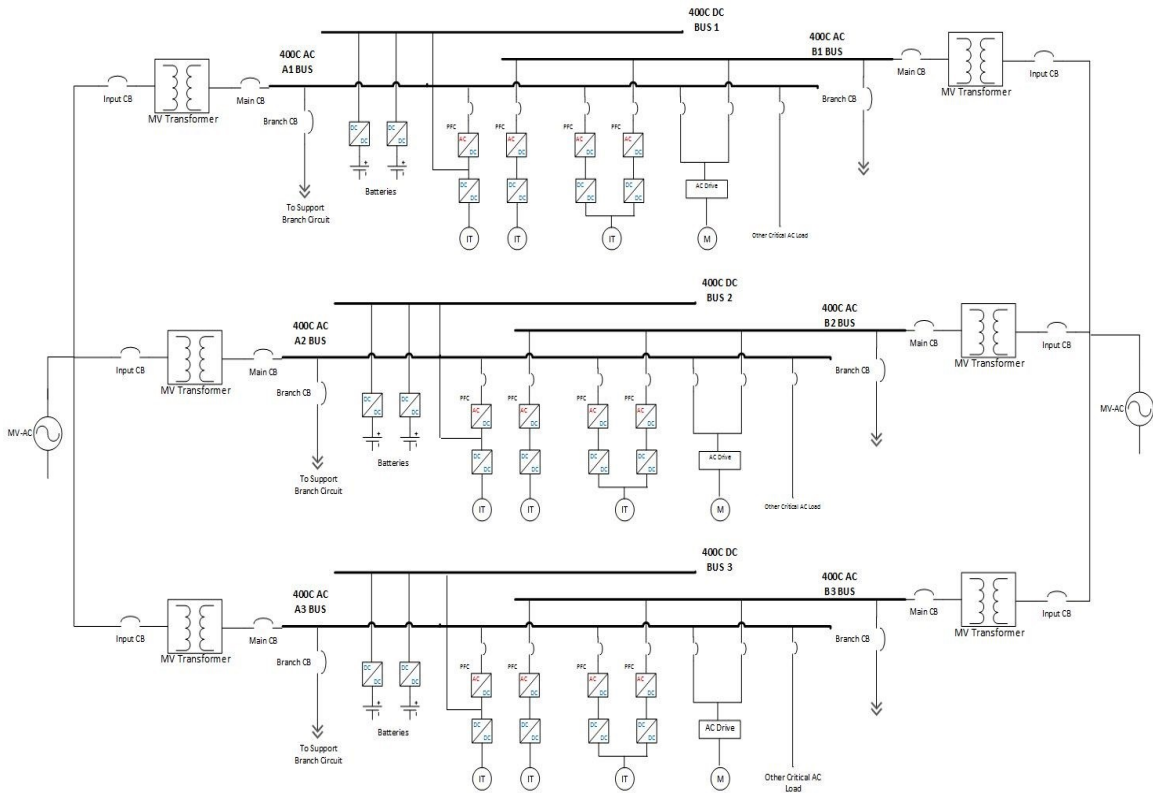

Figure 11 AC Distribution with one DC bus Schematic.

Since the UPS is a high power losses device, some researchers have updated the existing AC schematic shown in Fig 11. This system has three buses, two 400V AC buses and one 380V DC bus for the battery charging. This solution can reduce the conversions in UPS in order to increase the efficiency to 89% and add the stability for the energy storage [5]; however, the initial cost would be much higher than usual and not appropriate for retrofit of existing data center.

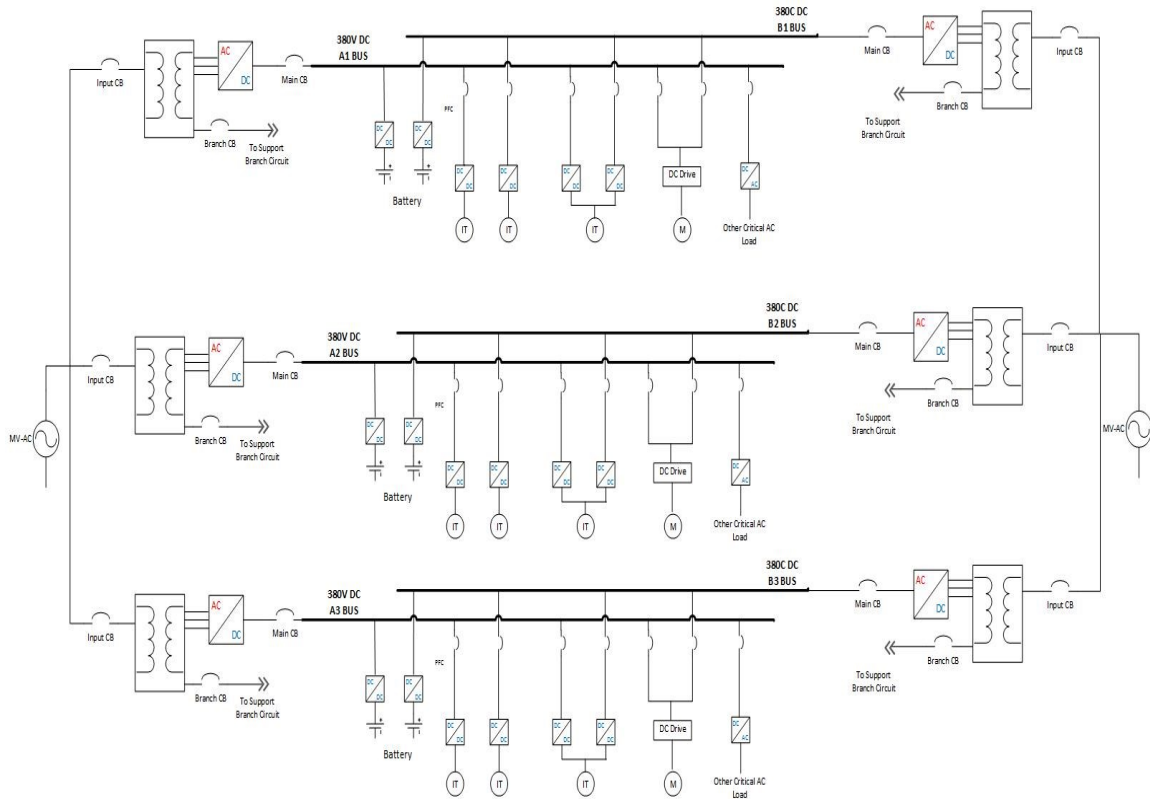

Figure 12 Proposed 380V DC Power Distribution System

To minimize the total power conversion stages, this proposed 380V DC Power Distribution System could be an ideal solution. In each IT rack, the 24 Pulse transformer is small scale that mostly like working as a current isolation. Moreover, it is connecting directly to the centralized AC/DC Conversion panel so the transformer can be recognized as one part of the converter. The main converter is a Buck-Type Current Source Rectifier converting the high voltage AC input to 380V DC output. The control topology is very complicate which will be introduced in Chapter III. The 380V AC Bus delivers power to each server and battery though a simple DC to DC converter located in PDU. Vital AC load has DC/AC inverter, system can provide power to induction motor by DC drive.

There is one diode in each phase to protect the bus and equipment from overcurrent caused by short circuit loads, very necessary for DC system. The whole system efficiency can reach 90% or even higher.

## 2.5 Optimized Date Center DC Distribution Structure

To design a network structure that is agile, resilience and can provide as much throughput as possible, the key is that how the server is connected with switches and other deployed devices [13]. Paper [13] provides four topologies with power consumption of each to illustrate the best structure for data center with different load. Among these four topologies' simulation results, "Balanced Tree" showed very strong and stable especially low power consumption performance in both high and media loads of data center. It is the optimized structure solution for the DC power distribution system as well. Shown in Fig 13, the balanced tree distributes its levels evenly between each branch. It has a single switch in the core, as the main circuit breaker in the schematic. Usually there will be  $n$  switch ports connecting with terminal block of main circuit breaker. The servers are located in the levels from each switch. If this solution has  $k$  structure levels so the whole structure can have  $n^k$  servers. The power consumption formula [13]:

$$\text{Watts} = E n^k + E_{sw} \sum_{i=0}^{k-1} n^i \quad (2)$$

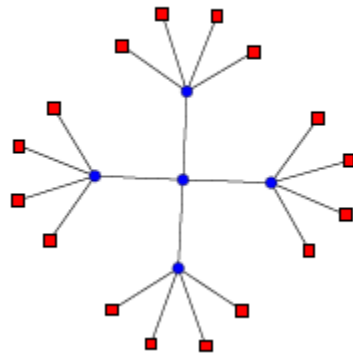

Figure 13 Balanced Tree [13].

## Chapter III Power Conversion

The power conversion system plays the most important role in the Data Center Proposed 380V DC Power Distribution System. The core converter topologies also the main contribute of this paper are buck type current source rectifier whose responsibility is converting AC to DC and voltage reduction from 10KV to 380V DC as well [14]. This Buck-type Current Source Rectifier applied to Data Center Power Distribution System may bring a significant and huge revolution in DC Power system especially for data centers.

Paper [17] and [18] provided a modulation scheme for three-phase three-switch buck-type rectifier to minimize the input filter capacitor voltage ripple and DC current ripple with low switching losses. Paper [19] proposed a comprehensive design of a three-phase three switch buck-type rectifier with system modulation and control topology. In [15], the three-phase six switches buck-type current source rectifier was first proposed for 400V DC Distribution System. The total conversion efficiency is optimized towards to 99% with methods for calculating losses of all components at full load.

In this paper, the design of the Proposed 380V DC Power Distribution System paid special attention to the three-phase six switches current source rectifier. The converter

operation theory and control topology has been updated to work with IT equipment load and semiconductor losses has been calculated based on the knowledge in [15].

### 3.1 Current Source Rectifier

In a typical AC Power Distribution System shown in Fig14, the power conversion from MV AC to 12V DC is 6 stages or more; however, the 380V DC Power Distribution System just have 3 stages with Buck-Type Current Source Rectifier [14]. In this way, 1MW DC system can be 10% more efficient than for comparable AC technology, while the costing is 15% less (14).

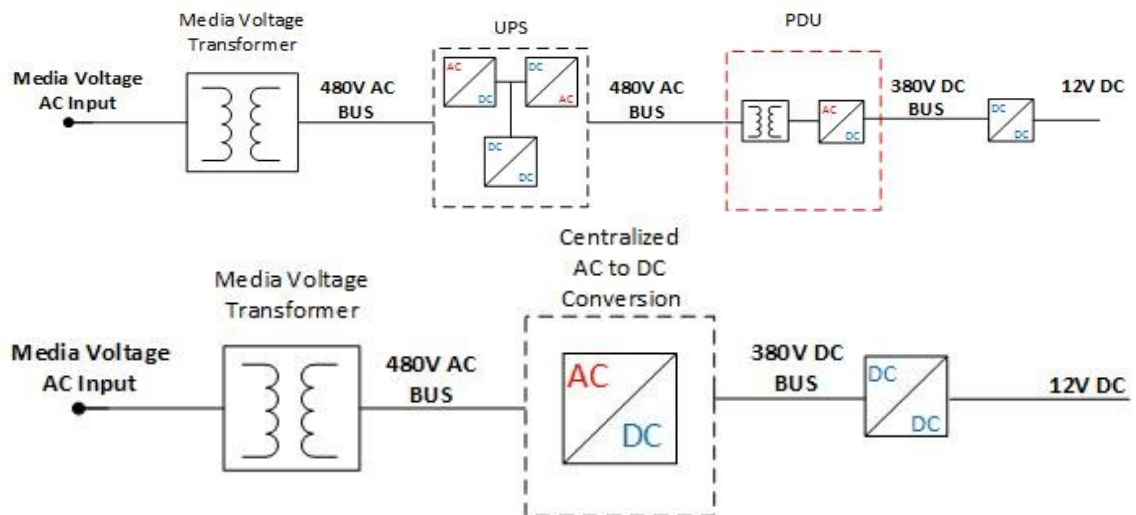

Figure 14 Detailed view of Typical AC Power System (top) and Proposed DC Power System (bottom) [14].

The three phase buck-type current source rectifier (CSR) can provide a wide output voltage control range from high to low voltages while allow for current limitation in the



case of an output short circuit [15]. That means the CSR is working as a current source to keep the output current under the limitation anytime to protect the overall power system especially the IT equipment. Both the efficiency and costing is highly increased because it potentially replaces all the “red” conversions in Fig 14 (top) and the power factor correction (PFC) is combined in the CSR. These are the advantages and benefit for picking up the CSR as the converter for proposed DC system.

The design of a high efficiency 10KW, 380V DC output, three-phase buck-type current source rectifier is optimized for 480V  $\pm 10\%$  AC input phase to phase rms voltage at 60Hz and peak efficiency at full load. The topology of the rectifier is given in Fig. 15. The six core semiconductors are designed to use high-voltage MOSFETS because they can provide better switching and higher efficiency performance due to lower forward voltage [15]. The two converter inductor is split evenly ( $L_1=L_2$ ) between the positive and negative path just in order to provide symmetric attenuation impedances for harmonic current [15].

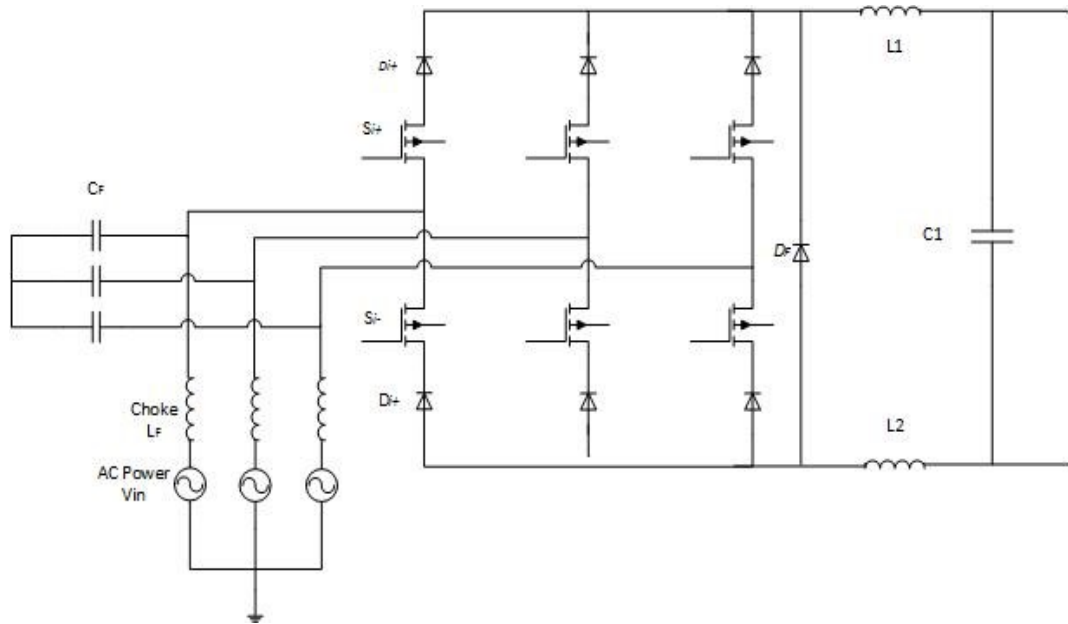

Figure 15 Conversion circuit schematic.

### 3.2 Simulation Models

The simulation of the converter was operated in MATLAB/SIMULINK. There were two simulation models with different control topologies proposed. Fig.16 is the screen capture of simulation model with voltage PI loop and current PI loop PWM control. Fig.17 is the screen capture of simulation model with DQ PWM control. Different control topologies with same converter model can result in large difference in voltage and current waveforms especially the DC's. Detailed information of the control strategy will be provided in Section 3.3.

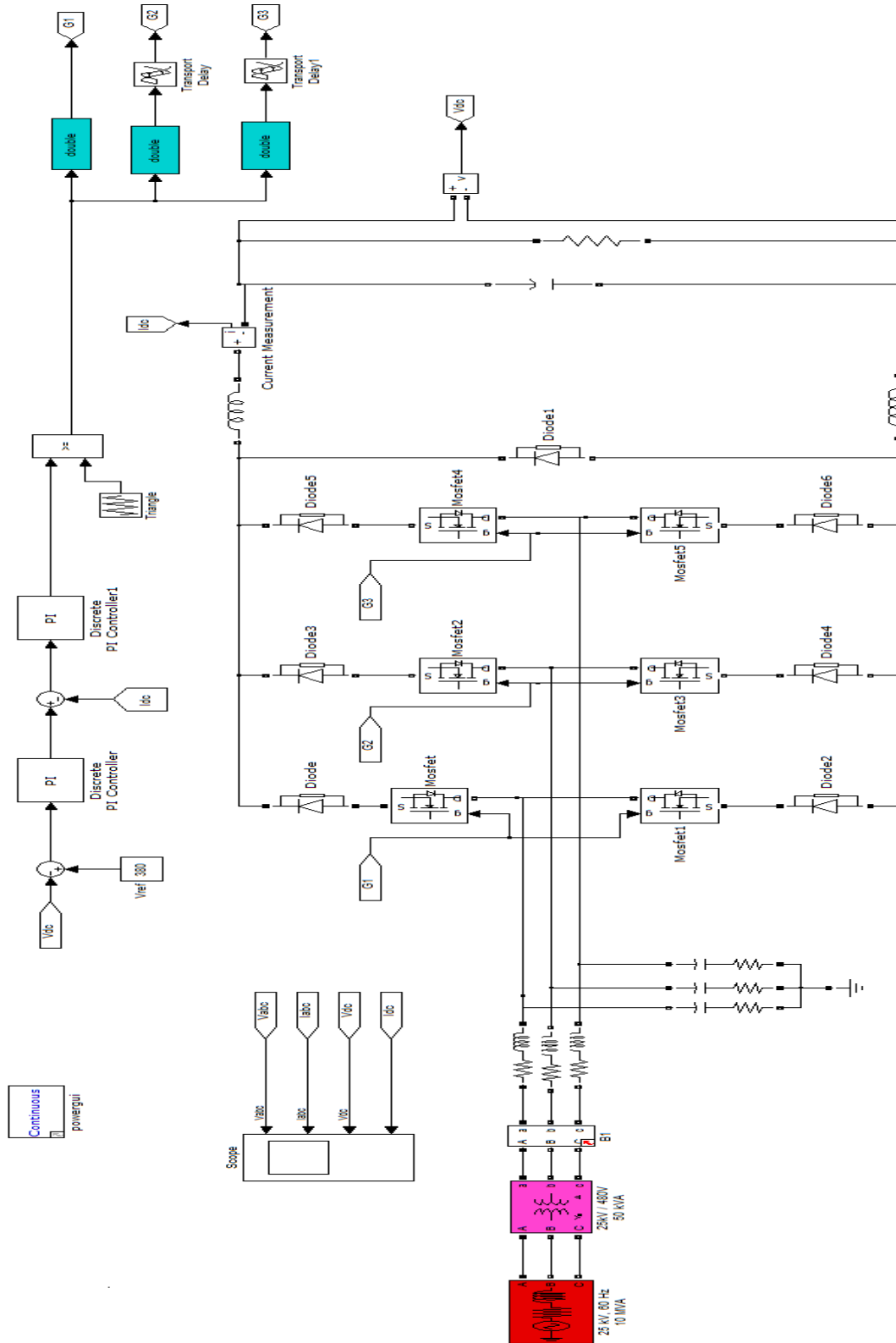

Figure 16 The screen capture of the converter system simulation module with current and voltage PI loop PWM control

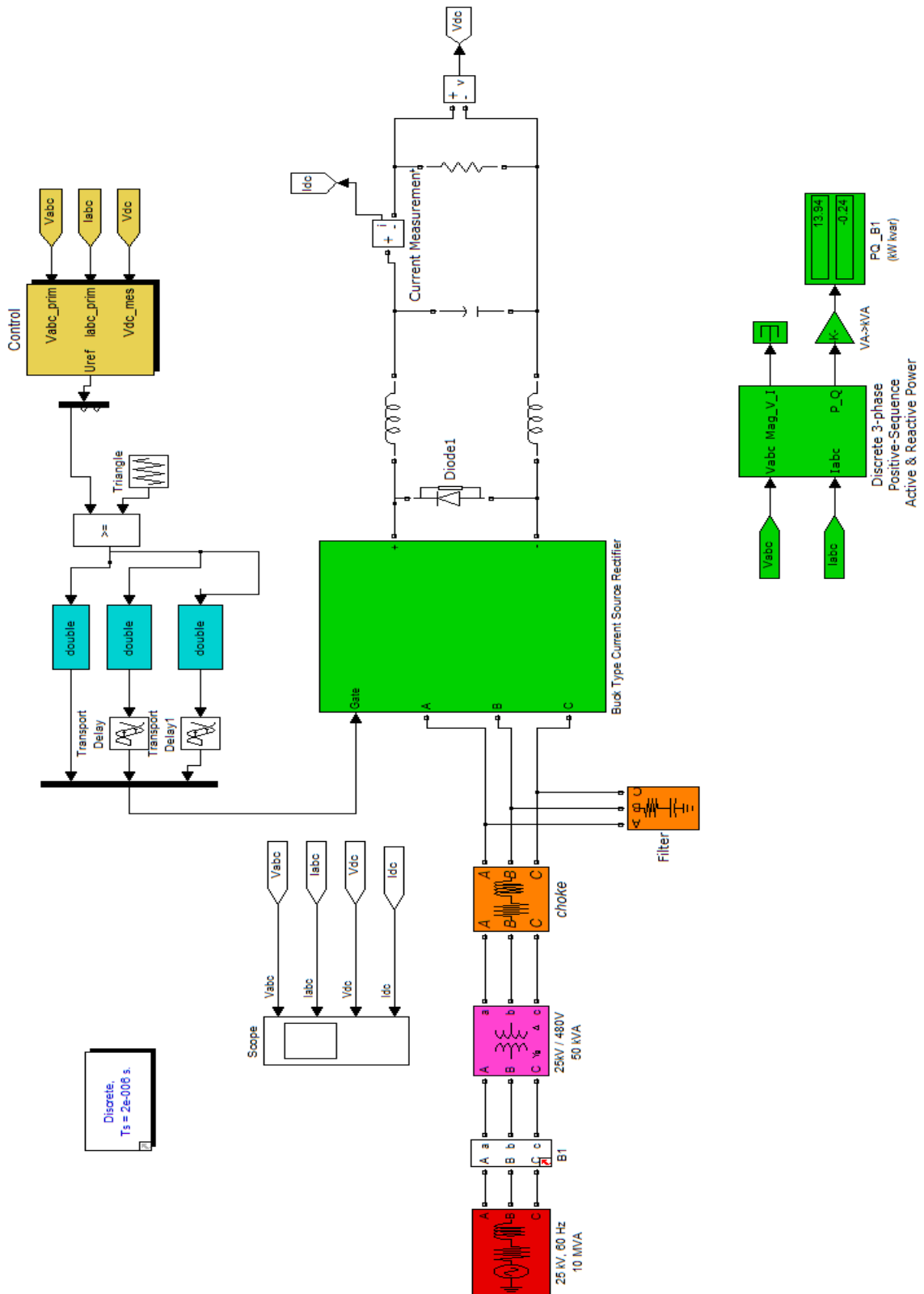

Figure 17 The screen capture of the converter system simulation module DQ PWM control

The input power (in red) is set as 25KV three phase AC input, power rating is 10MVA, which is representing the typical large scale data center power system. The Primary and Secondary side of the Media Voltage Transformer (in pink) are 25KV and 480V AC respectively. The choke and filter reduced the AC side current harmonic; in the PQ control model, the filter (in orange) also compensated reactive power to the conversion system. The green rectangle in DQ model is the six pulses buck type rectifier which the same as the one in the PI control model. There is one Mosfet and one diode in each arm. In this simulation, all the components are in idea condition. The load is simplified as resistor just for showing the output DC voltage and current. And next chapter will focus on the effective on output current and voltage with different loads. Other parameters in these two models are listed in below tables.

Choke	Filter	L1=L2	C1	Solver	Running time
R: 0.1ohms L: 2.1e-3H	R: 0.1ohms L: 1e-3F	L: 3e-2H	C: 8e-2F	Ode15s	T= 0.5s

Table 3 Parameter list of the PI PWM Control simulation module

Choke	Filter	L1=L2	C1	Solver	Running time
R: 0.1ohms L: 12.5e-3H	Reactive Power Qc: 4.5e3 Var	L: 3e-2H	C: 8e-2F	Discrete Ts=2e-6s	T= 1s

Table 4 Parameter list of the DQ PWM Control simulation module

### 3.3 Control Strategy and Results

The first PI PWM control has two loops, voltage and then the current loop. Fig. 18 is the diagram of this control strategy. Each loop has a same PI controller with different  $K_p$  and  $K_i$  listed in Table 5. The PWM carrier frequency is  $33 \times 60\text{Hz}$  brings the least harmonic in the translation system. The time period values of the triangle generator is

$$T = \frac{1}{f} = \frac{1}{33 \times 60} = 5.051 \times 10^{-4} \quad (3)$$

Based on the operation theory from [15], the two switches of each leg receiving the same gate signal is simplest way to control the switches. So the trigger signal of Phase B is 120 degree lag of Phase A and that of Phase C is 240 degree lag of Phase A.

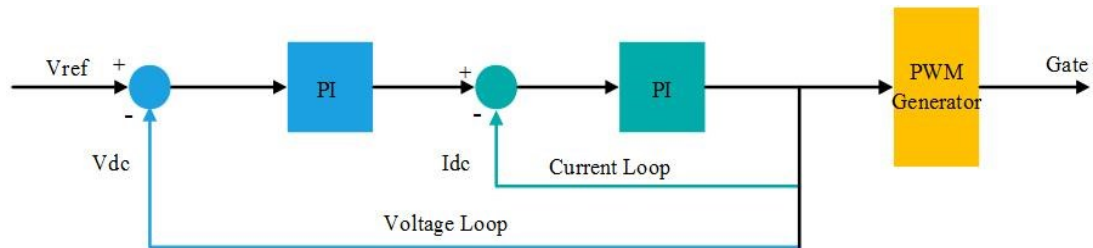

Figure 18 The diagram of the PI PWM control

	The voltage loop PI controller	The current loop PI controller
Proportional gain- $K_p$	8	2
Integral gain- $K_i$	0.05	0.005

Table 5 Parameter list of each PI PWM Controllers

Fig. 19 (upper) is the scope waveforms of input 480 V AC voltage  $V_{abc}$  and current  $I_{abc}$ ; bottom waveforms are the output 380V DC voltage  $V_{dc}$  and current  $I_{dc}$ . Before the DC

voltage reached the desired value, the current increased sharply to 350Amps due to the large inductance in the circuit and slow reaction of current loop. However, the current drops to zero for 0.01s before the voltage stable. These huge vibrations of the current can easily hit the protection relay trigger or burn the fuses in the bus. Moreover, this is also causing a very high reactive power which leads to an unacceptable low efficiency.

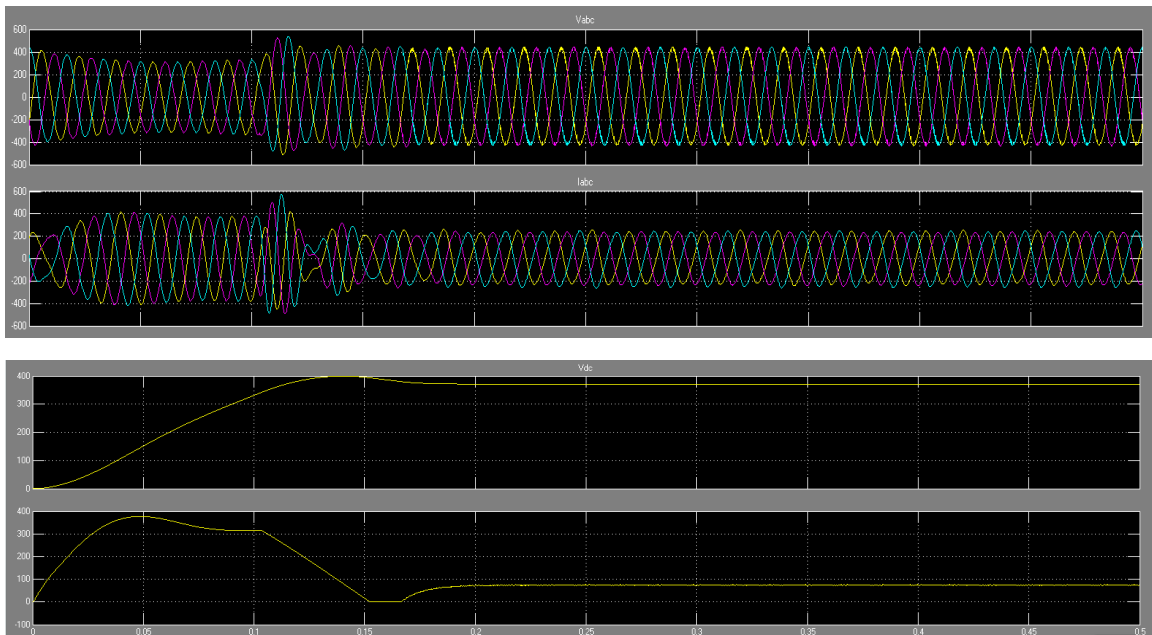

Figure 19 The scope waveforms of input AC voltage and current(upper); output DC voltage and current (bottom).

To overcome the entire disadvantage and improve the total conversion efficiency, taking the special load conditions of data center into account as well, a new control strategy has been developed for this Proposed DC Power Distribution System. To eliminate the reactive power in conversion system, space vector control theory is applied, which means three phase voltage  $V_{abc}$  and  $I_{abc}$  is represented by a  $d-q$  vector rotating at an arbitrary





angle  $\theta$  in the inverse matrix to produce the  $U_{abc-ref}$  for PWM generator.

$$x_{abc} = K^{-1}x_{dqo} = \sqrt{\frac{2}{3}} \begin{bmatrix} \cos(\theta) & -\sin(\theta) & \frac{\sqrt{2}}{2} \\ \cos(\theta - \frac{2\pi}{3}) & -\sin(\theta - \frac{2\pi}{3}) & \frac{\sqrt{2}}{2} \\ \cos(\theta + \frac{2\pi}{3}) & -\sin(\theta + \frac{2\pi}{3}) & \frac{\sqrt{2}}{2} \end{bmatrix} \begin{bmatrix} x_d \\ x_q \\ x_o \end{bmatrix} \quad (5)$$

**CSR Main Controller**

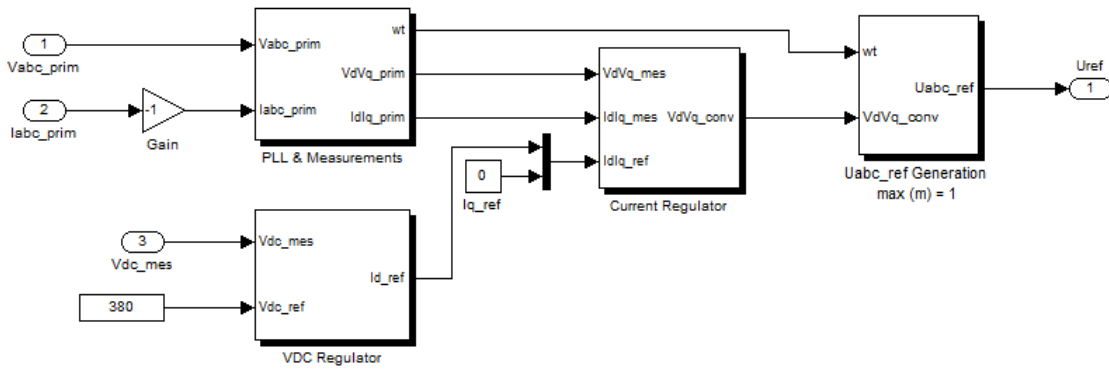

Function Block Parameters: Control

VSC Main Controller (mask)

Parameters

Nominal power and frequency [ Pnom(VA) Fnom(Hz) ]:  
50e3 60

Nominal primary and secondary voltages (Vrms LL) [ Vnom\_prim Vnom\_sec ]:  
25e3 480

Nominal DC bus voltage (V):  
380

Total transformer leakage impedance (pu/Pnom) [ Rxf Lxf ]:  
[0.008 0.04]

Choke impedance [ R(ohm) L(H) ]:  
[2e-3\*(2\*pi\*60)/50 2e-3]

VDC regulator gains [ Kp Ki ]:  
[7 800]

Current regulator gains [ Kp Ki ]:  
[0.3 20]\*1.5

Sample time  
Ts\_Control

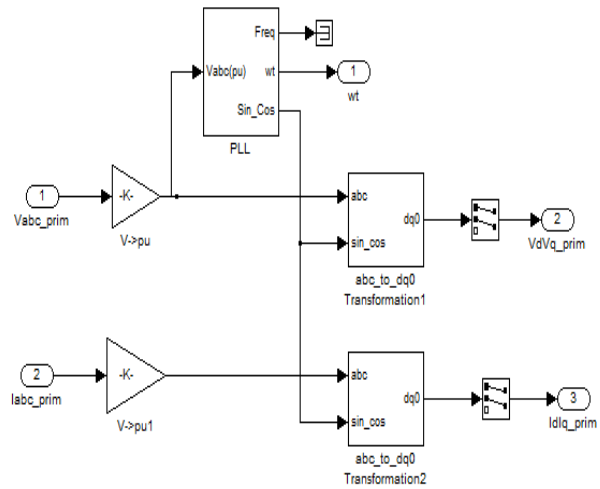

Figure 21 The schematic (upper) with parameter settings (lower left) and the subsystem of “PLL & Measurements” in the DQ PWM control in MATLAB/SIMULINK Model

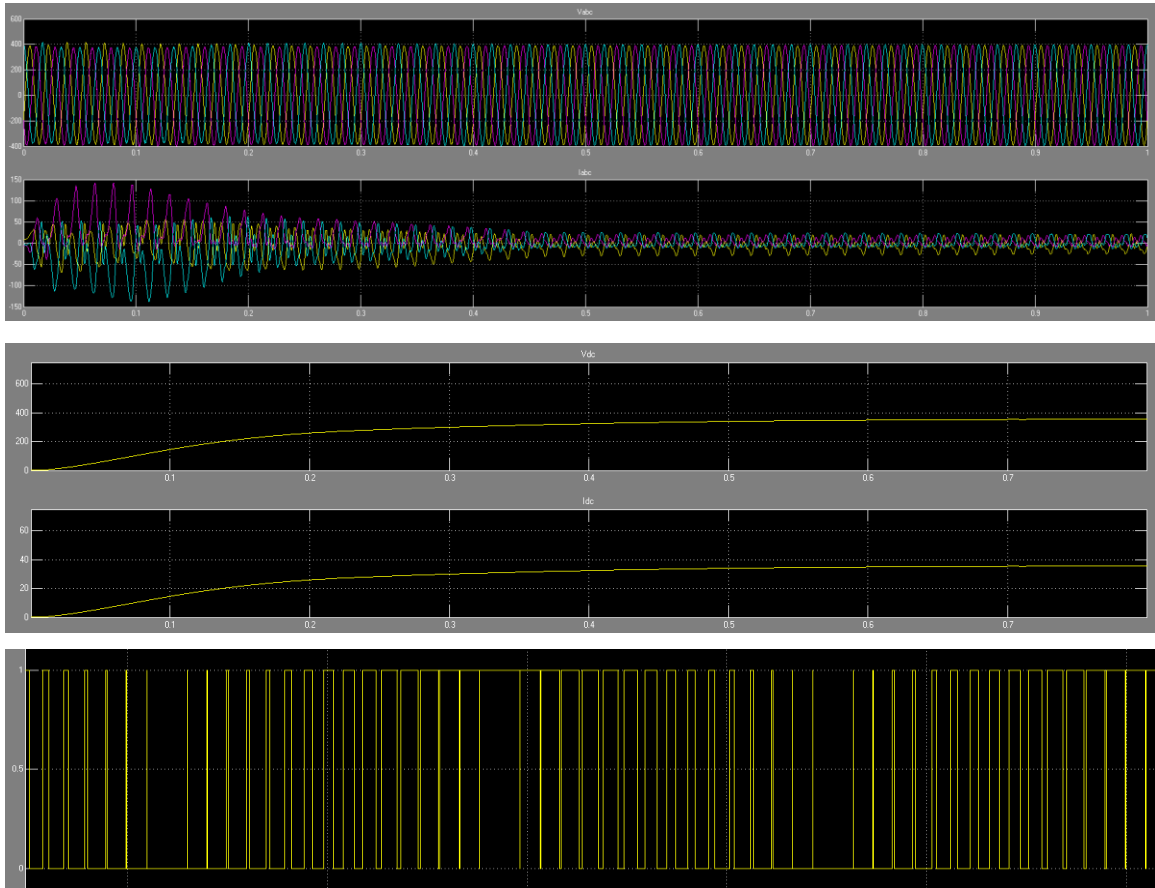

Figure 22 The scope waveforms of input AC voltage and current (upper); output DC voltage and current (middle) and PWM signal (bottom) .

Shown in Fig. 22, the output DC voltage increased from 0 to 380V very smoothly and quickly. The output DC current almost has the same appearance without any huge vibrations and ripples which significantly proved that the DQ controller reducing reactive power effectively. The power meter also certified this conclusion, with the reactive power ranging from -0.25Kvar to 0.25Kvar when the voltage is stable. However the real power is around 14KW. So the power factor is 0.98.

Compare this two control strategy applying in the same six-pulse Mosfet converter, it is no doubt that the Space Vector DQ PWM controller effectively improved the performance of output voltage and current for IT devices. On the other hand, the filter can absorb or provide more reactive power if necessary which has a profound effect on this centralized converter.

### 3.4 Voltage Source Rectifier and Buck Converters

Three-phase Buck-Type Voltage Source Rectifier (VSR) has some attractive features like high power factor, nearly sinusoidal input current compared with CSR and bidirectional power flow ability [20]. The difference of VSR and CSR is that there is no DC side inductor to limit the current shown in Fig 23.

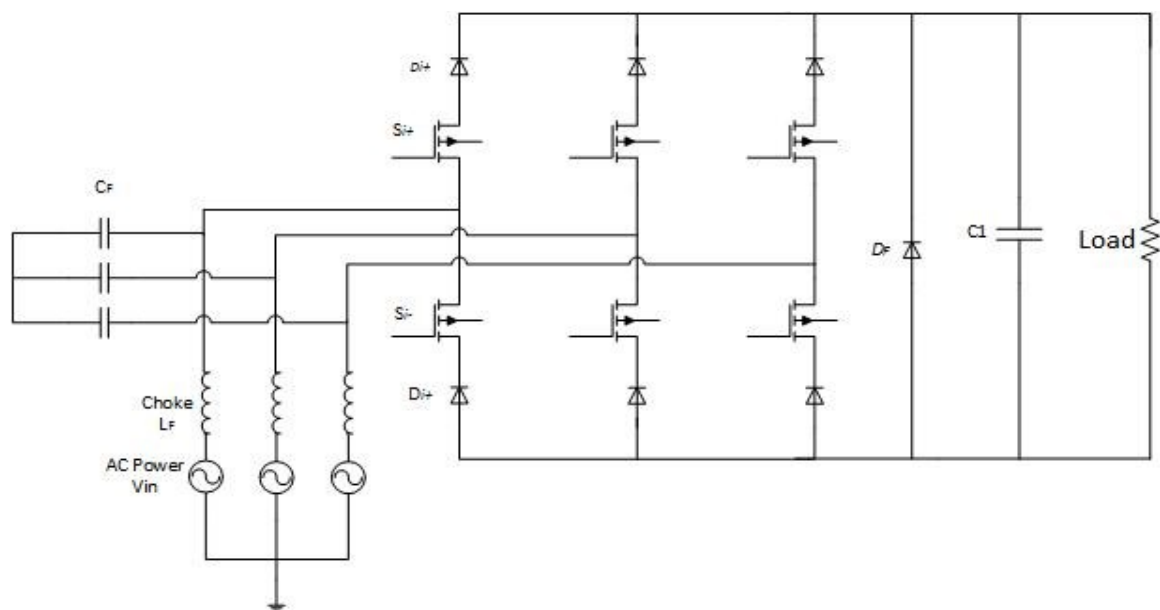

Figure 23 The circuit schematic of Voltage Source Rectifier

From the MATLAB/SIMULINK simulation model, with the same Space Vector DQ PWM Controller from CSR, the output DC voltage and current has a negative performance of stability and speed. Even the AC input current waveform is sinusoidal and less harmonic, this type of conversion cannot be guaranteed to be stability utilized under a wide-range rapidly varying load which is verified in [20]. So data center, IT servers are extremely expensive devices and very sensitive to the current variation that may cause serious damage. Comparing these two converters, CSR performed better in the stability and Speed characteristics, and also can protect the output current from increasing sharply. So the Proposed DC Power Distribution System still adopts Buck Type Current Source Rectifier.

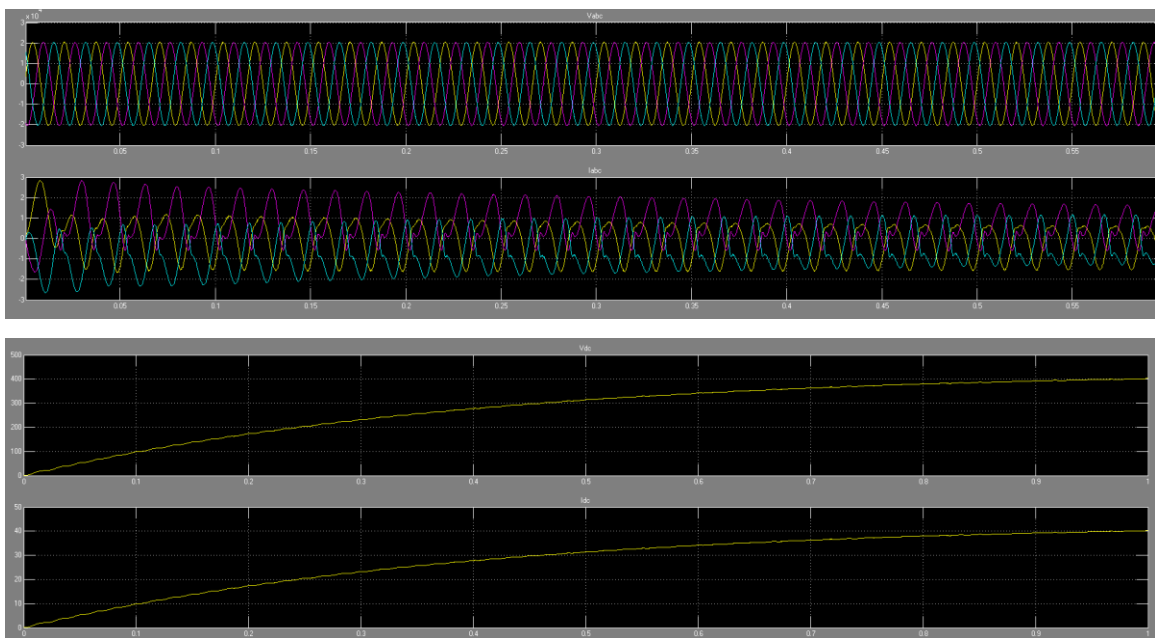

Figure 24 The scope waveforms of input AC voltage and current (upper); output DC voltage and current (bottom)

In the system schematic of Section 2.4, simple DC to DC Buck Converters connected with the circuit breaker of 380V Bus and servers' power input panel or other critical DC loads such as security and lighting. In [21], the Intel Servers utilized the 12V DC and 48V DC applied in other support devices. Two different output voltage simulation models of Buck Converter with PWM control have been conducted in MATLAB/SIMULINK. Fig. 25 is the simulation schematic through IGBT as the switch. Input DC voltage is set as 380V DC, and load is considered as a simple resistor (2ohms). The control topology is very simple those to change the output level, just reset the constant reference value in the feedback loop and modify the LC branch (L1 and C1).

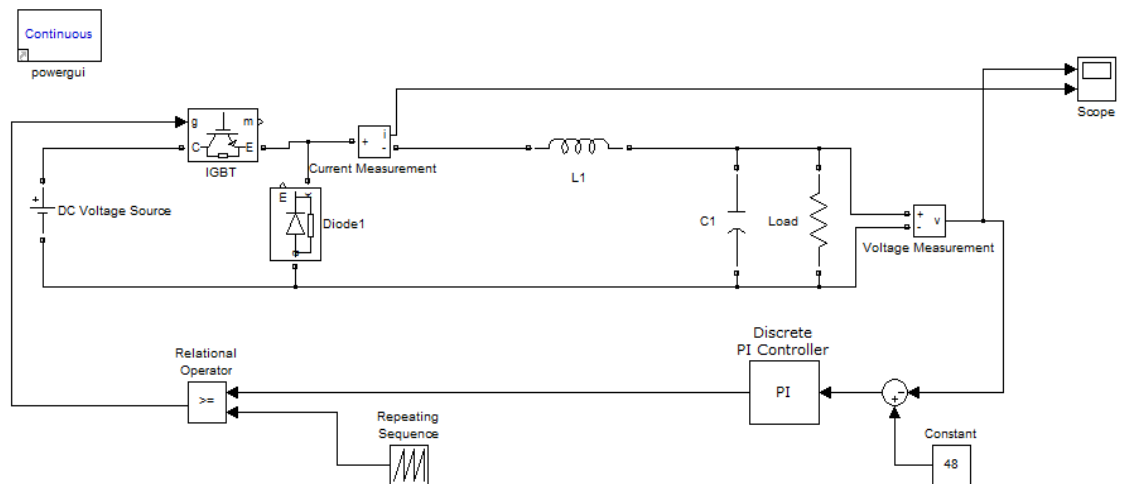

Figure 25 the circuit schematic of Buck Converter in MATLAB/SIMULINK

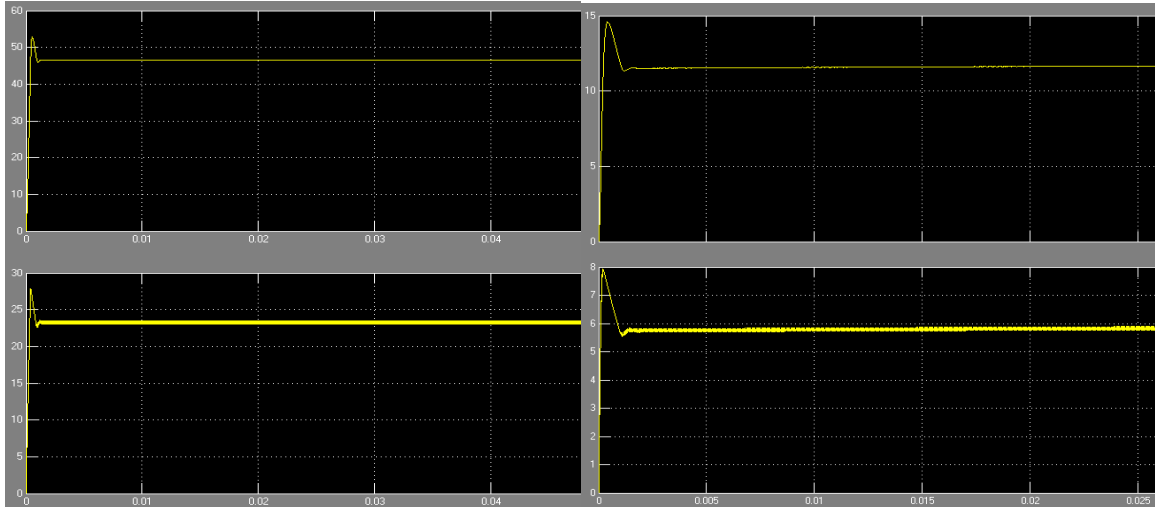

Figure 26 the scope waveforms of output voltage and current for 48V Level (left) and 12V Level (right).

### 3.5 DC Energy Storage

In the data center industry, there are varied types of uninterruptible power supplies (UPS) existing for AC Power Distribution systems. Different vendors provided models with similar design and topologies but with variable performance characteristics [22].

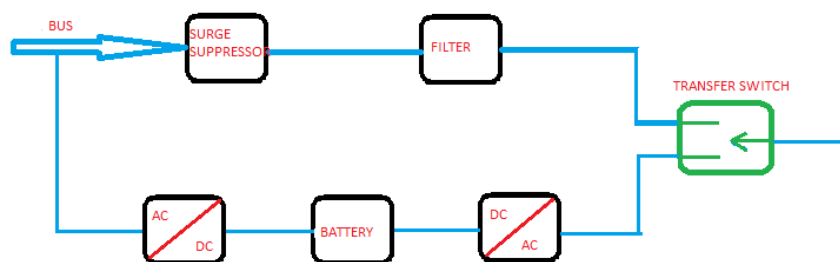

Figure 27 Standby AC UPS System diagram.

The widely used UPS system for computers and servers is called Standby UPS system shown in Fig.27.[22] The energy storage devices like battery charge and batteries, are connected in parallel with the primary power delivery source. The transfer switch is set to

choose the AC input as default, and when primary power fails, the transfer switch can operate to switch the load over to the battery as backup power source in dashed path. The battery only starts when fault happens but always ready for that, so named as “standby”.

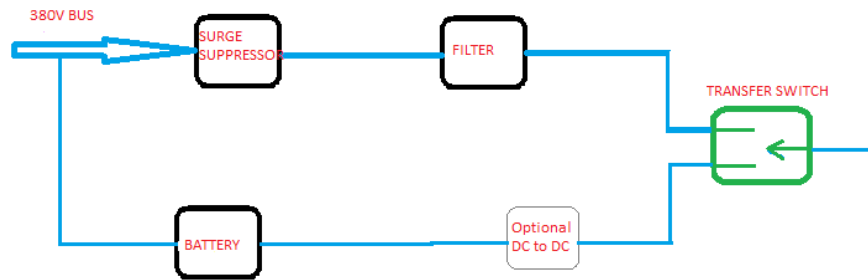

Figure 28 New Designed Standby DC UPS System diagram.

To work properly with the proposed 380V DC Distribution system, this paper designed a new DC UPS system. It is originally modified and updated from “standby” system but much simple and efficient than AC energy backup system because it doesn’t need at conversion or only small DC to DC Buck convert shown in Fig.28. The backup power devices deliver DC directly to the 380V Bus so every load can be energized even critical AC load. Usually one battery is 24V that means 380V output needs at least 15 batteries connecting in series.

## **Chapter IV Efficiency Modeling of Converter**

To design a high efficiency power distribution system, the electrical efficiency modeling must be built and analysis as precisely as possible in order to minimize unnecessary losses during the design stage. In Chapter III, the centralized CSR Buck-Type Converter is developed and simulated as the core part of this design. So in this Chapter, the power losses calculation and the effectiveness of variable loads will be provided to revise the performance of conversion system.

### **4.1 Calculation of Power Losses**

The power losses of this system mainly occur in the power conversion and voltage transformation stages. The centralized AC to DC Rectifier has conducted nearly 50kVA power so the losses would be significant for efficiency optimization. However, the PDU internal DC to DC Buck Converters have very low KVA ratings so that the power losses during this conversion can be ignored. An important feature of this proposed system is that all LV transformers have been eliminated in order to reducing losses to zero which is happened in this period. The losses during transmission and on other devices can also be negligible based on the design guidance of [19]. On the other hand, the power conversion losses can be broadly divided into two categories: losses of the semiconductors and losses of the passive components [19].



Research paper [19] has provided very detailed principle analysis of semiconductor losses for exporting calculation formulas. This paper didn't repeat the similar theoretical analysis, just applied all the calculation procedure to this special rectifier. The rms and average values of these series diode current  $I_{DS, rms}$  and average values of Mosfet current  $I_S$ , and freewheeling diode current  $I_{DF}$  can be got from (6) to (9): [19]

$$I_{DS,avg} = I_{S,avg} = \frac{I_N}{\pi} \quad (6)$$

$$I_{DS,rms} = I_{S,rms} = \frac{I_N}{\sqrt{M\pi}} \quad (7)$$

$$I_{DF,avg} = \left(\frac{1}{M} - \frac{3}{\pi}\right) I_N \quad (8)$$

$$I_{DF,rms} = \sqrt{\left(\frac{1}{M^2} - \frac{3}{M\pi}\right)} I_N \quad (9)$$

Where the  $I_N$  is the input phase current rms value, is always affected by the loads. To simplify the calculation, the load was set as 80% load. So in the scope, the phase current  $I_N$  is read around 20Amps and the rms value  $I_{N,rms}$  equals 20/1.732 is 12Amps.  $M$  is called the modulation index, can be calculated as (10):

$$M = \frac{\sqrt{2}V_{DC}}{3V_{L-N,rms}} = \frac{\sqrt{2} \times 380V}{3 \times (480/\sqrt{3})V} = 0.6467 \quad (10)$$

So the result are  $I_{DS,avg} = 3.82A$ ,  $I_{DS,rms} = 8.42A$ ,  $I_{DF,avg} = 7.10A$ ,  $I_{DF,rms} = 11.48A$ .

The total semiconductor losses of Mosfet  $P_S$ , series diode  $P_{DS}$  and freewheeling diode  $P_{DF}$  is been calculated as below: [19]

$$P_S = 6I_{S,rms}^2 \frac{R_{DS,ON}}{n_S} \quad (11)$$

$$P_{DS} = 6(I_{DS,rms}^2 \frac{R_D}{n_D} + I_{DS,avg} V_D) \quad (12)$$

$$P_{DF} = (I_{DF,rms}^2 \frac{R_D}{n_{DF}} + I_{DF,avg} V_D) \quad (13)$$

Where the  $R_{DS,ON}$  is the Mosfet on-resistance set as 0.1Ohms;  $n_s$  is the number of transistors paralleled for each switch equals 2;  $R_D$  is the diode turn-on resistance which is 0.01Ohms;  $n_D$  is the number of devices paralleled for each diode that is same as  $n_s=2$ ;  $V_D$  is the diode forward voltage which is 0.7V usually. When running the calculation, we can get the estimated power losses values:

Mosfet Losses $P_s$	Series Diode Losses $P_{DS}$	Flyback Diode Losses $P_{DF}$
21.27W	18.17W	5.63W

Table 6 Power Losses Values of semiconductors

The Semiconductor Power Losses is around 45W when the load was constant at 80% in this power conversion system. Actually the switching losses consist of two main portions. One is overlapping of current during the switch transitions; the other one is caused by the charging and discharging of the parasitic capacitances of the Mosfet and diodes [19]. When considering these factors, the turn-on losses due to overlapping of current and parasitic capacitors can be calculated as below: [19]

$$P_{ON} = \frac{6}{\pi} V_{L-N,rms} \frac{\sqrt{3}}{4} I_L t_{tr} f_{SW} \quad (14)$$

Where the  $I_L$  is the output inductor current,  $t_{tr}$  is the switching time and  $f_{SW}$  is the switching frequency. But comparing the turn-on losses with conduction losses, Former calculation did not include these cases meaning the actual power losses would be a little

bit higher. However, to optimize the efficiency in the design level, the only thing could be controlled is the number of paralleled semiconductors. Fig.29 is from previous research paper [19] showing the relationship of total losses with numbers of switches and diodes in parallel. As can be seen, the curves are nearly flat when switch number is between 6 and 11; diodes number is between 7 and 15. Optimal is  $n_s=7$ ,  $n_d=4$  which only cost  $11+26.8=37.8\text{W}$ . However, considering devices cost and converter implementation, the number was set as  $n_s=n_d=6$  costing  $39\text{W}$  just  $1.2\text{W}$  higher than optimal pair but less cost.

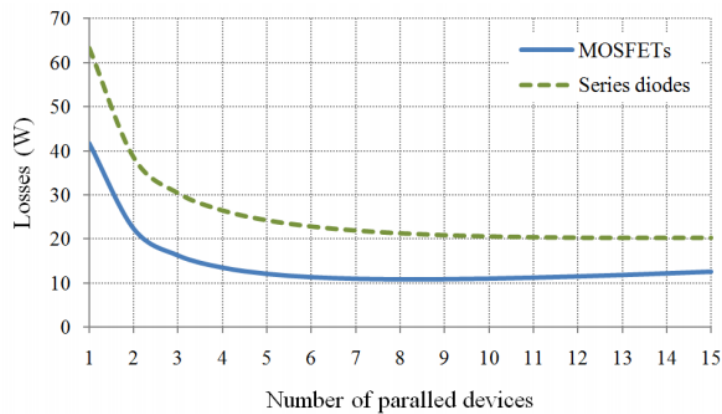

Figure 29 Total semiconductor power losses depending on the numbers of parallel switches and diodes.[19]

The output inductors and capacitors can not only provide losses on semiconductor devices, but also cause losses due to winding resistance, core and high frequency. The losses in output capacitors caused by equivalent series resistance and by leakage current. Paper [19] provides very detailed formula derivation process. When taking the inductance current harmonics into account, the total losses  $P_L$  and  $P_C$  are shown below:

$$P_L = I_L^2 R_{L,DC} + \sum_{n=1}^{n_{tot}} \frac{\Delta I_{L,n}^2}{3} R_L + P_{core} \quad (15)$$

$$P_C = I_{C,rms}^2 \frac{\tan(\delta)}{2\pi f_{sw} C} + I_{leak} V_C \quad (16)$$

When running at full load  $I_L = 25A$ , the two losses plus together were less than 10W and can't be improved from design step.

Total losses calculated for this converter were around 55W when running at 80% load, giving the efficiency at 98.35%. Breakdown the total losses, semiconductors account for over 80% and dominate the total. The improvement of semiconductors properties would be the significant way to decrease losses and achieving unit efficiency.

## 4.2 Effectiveness of Variable Loads

In this data center power distribution system, the variable IT loads significantly affect overall performance of system components. Efficiency of power and other support equipment is not constant and not independent of IT loads. However, the converter should keep the output DC voltage constant and current under the limitation when the load varies. In this section, the effectiveness of variable loads on converter output and other components is provided to verify the stability performance of this data center power distribution system.

This power conversion and transmission system is initially designed for 50KVA, however

considering support power equipment, power losses and safety issues, the output power to IT loads would reach 10KVA. In this case, the maximum current  $I_{DC}$  approximately equals  $10\text{KVA}/380\text{V}$  is 25Amps. So at full load,  $I_{DC} = 25\text{A}$ ; 80% load,  $I_{DC} = 20\text{A}$ ; 50% load,  $I_{DC} = 12.5\text{A}$ ; 30% load,  $I_{DC} = 7.5\text{A}$ . Next step is to run the simulation model to verify if the simulation result matches the assumption.

Full load,  $I_{DC} = 25\text{A}$

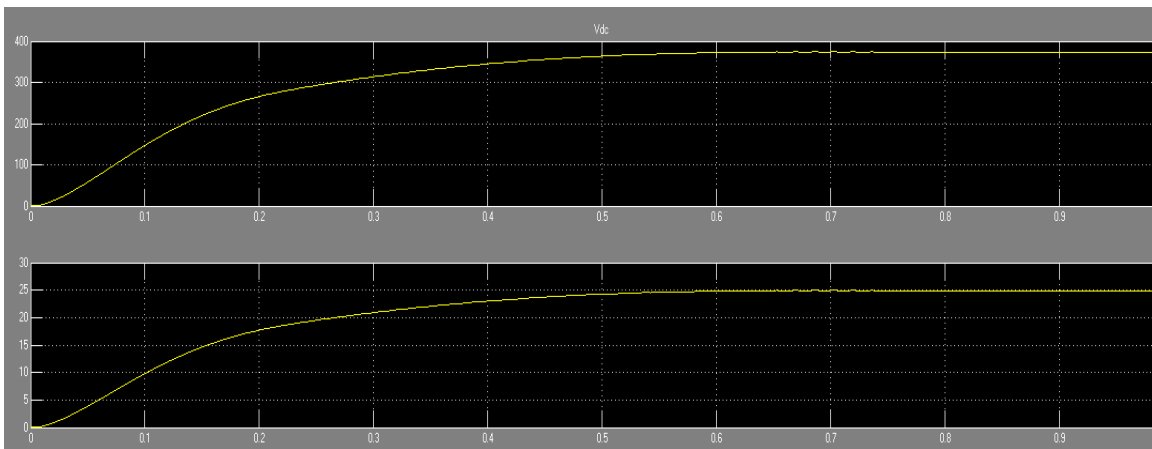

80% load,  $I_{DC} = 20\text{A}$

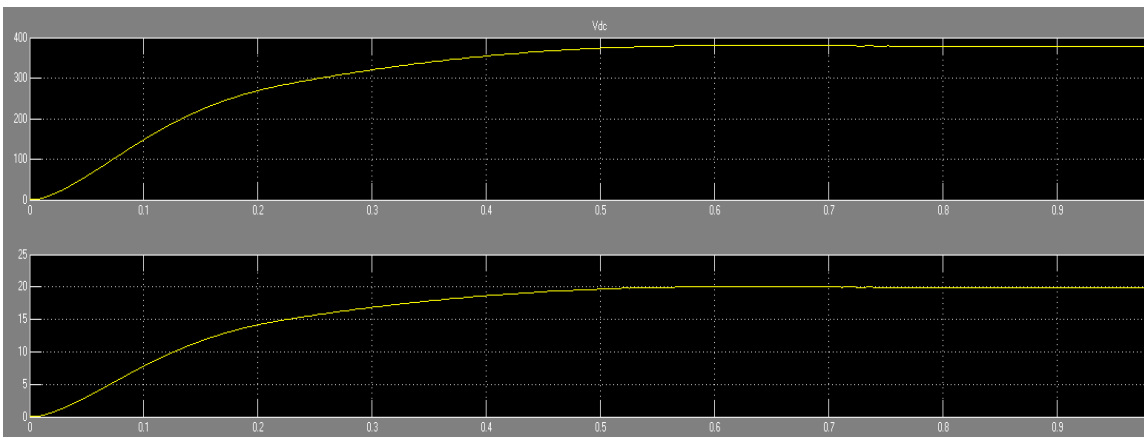

50% load,  $I_{DC} = 12.5A$

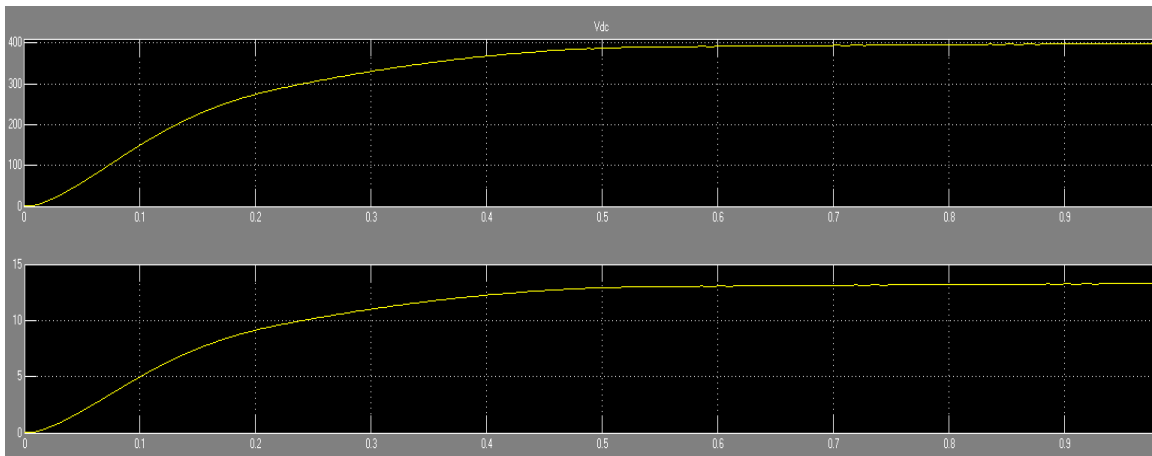

30% load,  $I_{DC} = 7.5A$

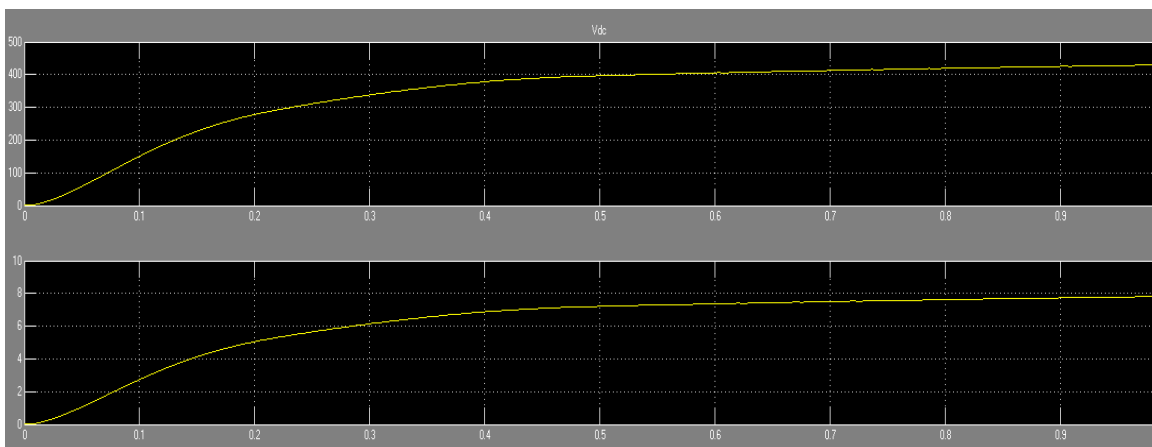

Figure 30 Output DC Voltage and Current under variable loads

In the scope waveforms as can be seen, the output DC voltage climbed to more than 400V when the system is running at less than 50% load. So operator should run the system at 80% load which can bring the most stable and accurate waveforms. From the efficiency point, running at low load mode means the energy cost by the LC devices and support devices accounts for a very large proportion which definitely lower the overall

efficiency. Paper [10] went through the efficiency curves of almost all electrical equipment in data center and got the conclusion said “Efficiency of components-especially CRAC units and UPS-significantly decreases at lower IT loads”.

CRAC means Computer Room Air Conditioning, on behalf of the support devices.

Improving model of data center overall efficiency depends on the accurately individual components. Usually the common method is to set a single constant value to represent the efficiency which is inadequate when designing the data center power system. Let’s take UPS Efficiency as one example shown in Fig.31. The actual efficiency of an energized component is not constant, but rather looks like a function of load conditions. We prefer 80% load for the best converter performance, and looking at this curve, UPS efficiency can almost reach 90% when running at the same load condition. The same conditions also happened on other power or support devices.

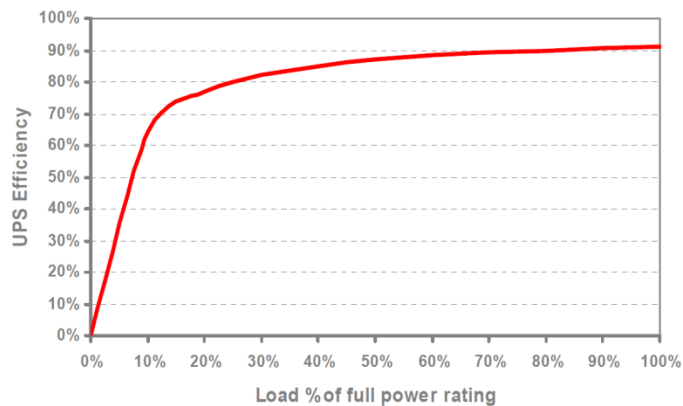

Figure 31 Typical efficiency of a UPS as a function of IT loads. [10]

Through the simulation model's analysis and other paper's verification, it is confident to say that the minimum effectiveness of variable loads is running at 80% IT load.



# **Chapter V System Power and Efficiency Calculation**

After the circuit simulation design and efficiency modeling of the power conversion system, this chapter will discuss about the power and efficiency calculation of whole system. Through the calculation of total power and PUE, this paper can exhibit the expected energy savings in order to evaluating the electrical efficiency modeling's function and comprehensive performance.

## **5.1 Calculating Total Power Requirements**

One part of data center power system design is to match the power and cooling requirements of IT equipment and make sure the capacity of infrastructure equipment can provide it. In this section, the calculation methods for power and cooling requirements is provided and analysis for determining the total electrical power capacity needed to support this data center are presented.

To design the capabilities of data center environment, regardless of the scale, should be start with the needs assessment. This assessment essentially builds the available capacity for the data applications processed by IT server. Paper [25] provides three configurations which are “N, N+1, 2N”, to identify additional IT internal power needs. “N” means that

there is no redundancy to increase availability for possible sharply increased IT load requirement. Time sensitive sites may have “N+1” topology for building a unit of redundancy in critical components and system. “2N” topology is designed for very important data centers applications where all the critical systems should be redundant. Based on the data center load profile, actual load may higher than the estimated full load (100% load). The calculated power requirement should have redundancy for all loads. So to simplify the calculation process, total calculated all loads power requirement will be added extra 50% electrical power capacity needed according to “N+1” topology. And the two buses have the same capacity.

As discussed in previous Section 2.3, power flow separated into critical loads and support loads. Critical loads are all types of hardware devices that assembly in IT cabinet which has data nameplates indicating power ratings at full load. Former studies and power supply manufacturers confirmed that the data nameplate rating of most IT devices should be above the actual running load by a factor of at least 33% [25]. On the other hand, data center loads are not always static with the rapid development of IT industry. There should be a realistic estimate of future IT organization changes and update to allow proper initial determination of load power requirements when designing. Support loads do not need any redundancy such as lighting and cooling. Usually lighting load is 21.5 Watts per square meter [25]. The cooling load and efficiency maybe vary widely due to different

heat generated inside and ambient outside. To keep the calculation simple, the cooling system will running at full load and maximum allowed ambient.

<b>Power Requirement</b>			
<b>Number</b>	<b>Item</b>	<b>Calculation</b>	<b>Subtotal Power</b>
1	Critical loads-total IT load estimated power	(Data nameplate power * 10 units * 1.33)/1000	$(451 * 10 * 1.33) / 1000 = 6 \text{KW}$
2	The critical loads besides server (including fire and security)	100W/1000	0.1KW
3	Future Loads	#1*0.2	$6 \text{KW} * 0.2 = 1.2 \text{KW}$
4	Lighting	$(21.5 \text{W/m}^2 * 100 \text{m}^2) / 1000$	2.15KW
5	UPS, Battery, Switch and converter power losses	$(\#1 + \#2 + \#3) * 0.32 + 0.055$	$(6 + 0.1 + 1.2) * 0.32 + 0.055 = 2.39 \text{KW}$
6	Total Power to fill in electrical demands	#1+#2+#3+#4+#5	11.84KW
7	Cooling	#6*0.7	$11.84 \text{KW} * 0.7 = 8.29 \text{KW}$
8	Total Power required	#6+#7	$11.84 \text{KW} + 8.29 \text{KW} = 20.13 \text{KW}$
<b>Power Capacity</b>			
9	2N	#8*1.5	$20.13 \text{KW} * 1.5 = 30.20 \text{KW}$

Table 7 Data Center Power Requirement and Power Capacity estimated calculation sheet

Based on the power requirement theory discussed above, the total power consumption and the estimated of the electrical service needed to support all the loads in data center, the Table 7 included all the items and calculation. We assume the data center's size is 100 squares meter and it has 10 units of "Cisco UCS C200 M2 SFF" server with peak power usage of 451W on the data nameplate. From the table above, estimated power capacity at full load, peak power usage is 30.2KW which is lower than the designed power converter system capacity-50KVA.

## **5.2 Calculation of Efficiency (PUE)**

Power Usage Effectiveness (PUE), as an effective energy management standard, has been widely recognized and utilized to determine data center infrastructure efficiency. Section 2.3 has provided the theory and formula of PUE and one energy consumption percentage table as an example. In this section, the PUE definition of this DC Power Distribution System is proposed and calculated.

PUE is Total Facility Power (or Total Input Power) divided by IT Load Power. Facility Power consumption units including physical infrastructure, IT loads, energy shared devices and neither sources. So issues exist here that caused difficulty to classify "power consuming subsystems", which necessarily need a standard approach to collecting all power consumption values [24]. Previous research paper [24] has defined a "Three-part

methodology” to overcome these problems:

- Categorize data center subsystems as either IT loads, physical infrastructure or not included as all [24].
- If a sub-system’s power consumption cannot be directly measured due to load sharing or technical barriers, approximately estimate power consumption of these sub-systems through “standardized methodology” [24].

However, the power distribution system in this paper is focus on the power conversion system, so it is unnecessary to measure and calculate impractical power consumption. IT loads including various hardware devices such as servers, storage equipment, networking gear, disaster recovery IT loads, network operation center, etc. [24]. Considering future loads, the total estimated power consumption by IT loads are 7.2KW based on the power requirement calculation in last section. On the other hand, physical infrastructure covers almost all the electrical devices that installed in data center. During transmission process, switchgears, panel boards, UPS and PDU consumed power should be count in; chillers, pumps and air compressors in the cooling system which support to keep a constant environment has been added in; at last the lighting system has outdoor lights and office light which has been calculated in power requirement but should be eliminated from physical infrastructure, so we take 70% lighting power out. Finally the PUE under full load conditions can be calculated as:

$$PUE = \frac{\text{Total Facility Power}}{\text{Total IT Load Power}} = \frac{19.03KW}{7.2KW} = 2.64 \quad (17)$$

Some commercial companies such as Schneider Electric provide online Data Center PUE Calculation tools that can quickly estimate the efficiency numbers by considering all the parameters. IT capacity is 30kW from last section, and PUE value is 2.26, lower than the result shown in (17). The benefit of this online tool is that through checking some options, the effectiveness of PUE showed up immediately. For example, by checking in the “PDUs without transformers” option corresponding to Proposed DC Power Distribution System, PUE dropped from 2.55 to 2.26 which means this new designed centralized power conversion system-Buck-Type CSR is extremely successful.

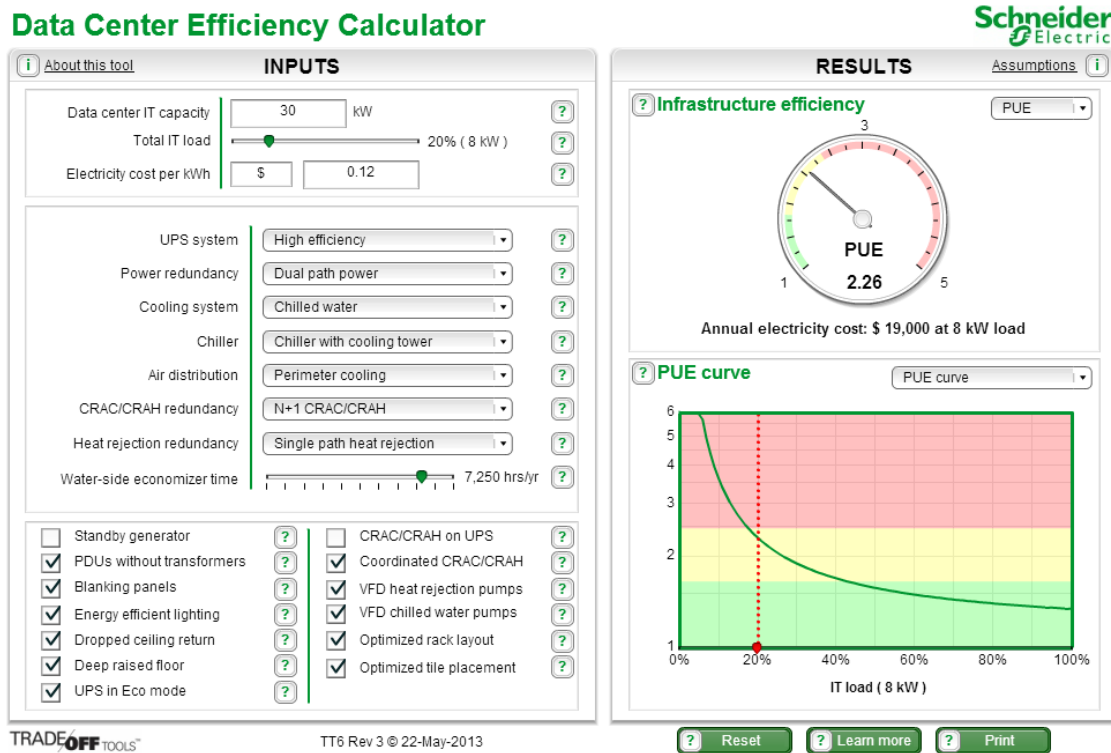

Figure 32 Data Center Efficiency Calculator online tool.

Source: [http://www.apcmmedia.com/salestools/WTOL-7CMGPL/WTOL-7CMGPL\\_R3\\_EN.swf](http://www.apcmmedia.com/salestools/WTOL-7CMGPL/WTOL-7CMGPL_R3_EN.swf)

### 5.3 Expected Energy Savings

The efficiency benefit of the DC Power Distribution System has been discussed in the previous sections. Through reducing power conversion steps and eliminating PDU transformers, it could reach an efficient, low power losses system. Moreover, the power requirement and PUE calculation can definitely help to quantitatively compare the power consumption and efficiency between the modern 208 V AC System and future 380V DC System.

To more intuitively understood the efficiency improvement and power consumption

reduction, this section still use the online tools “Data Center AC vs. DC Calculator” shown in Fig. 33. The results from this online tool are not actual conditions because the UPS, PDU and Power Supply efficiency are estimated values through the former calculations; however it is still a good reference. It is obvious can be seen that Power Path efficiency of 380V DC is 10% and 5% higher than modern 208V AC 415V AC respectively. Through power reduction figure, the power reduction of 380 V DC is 7.6% lower than that of 208V AC; that means in this 30KVA capacity system, in a typical cost of electrical power-0.12 per kW hr, the 380V DC system can save:  $30\text{KW} \times 7.6\% \times 0.12\$/\text{kW hr} \times 8760 \text{ hrs} = \$2396$ . This attractive payback absolutely draw people’s attention on this DC Power System even the capital cost is higher.



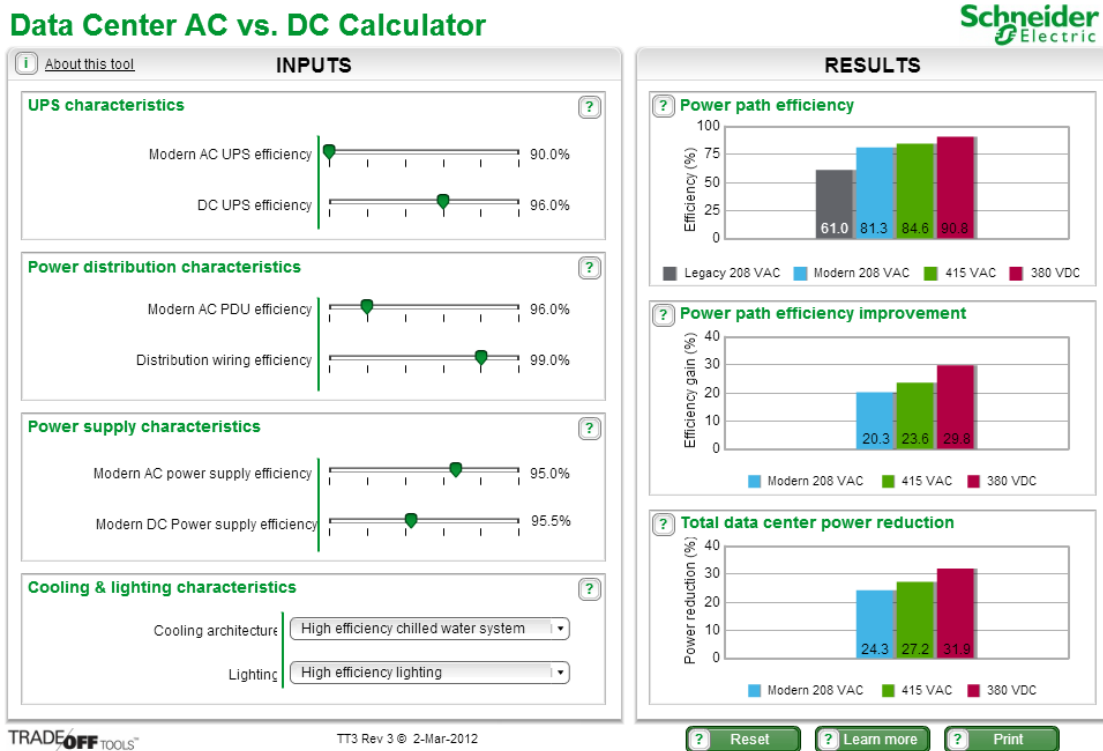

Figure 33 Data Center AC vs DC Calculator online tool.

Source: [http://www.apcmedia.com/salestools/WTOL-7DYKX4/WTOL-7DYKX4\\_R1\\_EN.swf](http://www.apcmedia.com/salestools/WTOL-7DYKX4/WTOL-7DYKX4_R1_EN.swf)

## 5.4 Opportunities for Additional Energy and Efficiency Savings

The proposed 380V DC Power Distribution system has been proved in previous sections that the system efficiency is significantly improved and total power consumption especially power losses during transmission are extreme decreased. However, there are also some additional methods can be applied for further improvement and savings. So this section will introduce some opportunities maybe applied in the future.

Regarding to reducing energy cost, there is a key principle to understand saying that

“reducing energy consumption can reduce the power capacity as well as energy cost” [11].

That is an implementation that saves electricity energy should be driven by reducing the power capacity which is mainly composed of IT load and DCPI power demands. However, the infrastructure costs are also primarily affected by load. Reducing energy consumption temporarily just focuses on DCPI, but to reducing energy consumption permanently, IT loads related power requirement capacity must be improved clearly.

The reduction of IT equipment power consumption consists of many approaches: [11]

- Operation respect: Retiring uncritical servers, operating management efficient system and platforms.
- Component respect: Software, hardware, software and network.

The purpose of operational improvement is to shut down the servers that have no users and running system with maximum advantage of power management features. Paper [1] table 3-6 is the “Potential Energy-Efficiency Improvement Opportunities for Servers and Data Center” that included all the possible improvement solutions for hardware, software system, network, control and heat removal. At the end of this table in “distributed Generation” section, there are two items called “Use renewable energy (e.g., photovoltaic panels)” and “Use fuel cells”.

Renewable energy is becoming more and more popular and useful in power generation

system, not only no CO<sub>2</sub> emission, but also can bring large scale of economic benefits. What is more, there are few researches working on design data center power distribution system with renewable as energy source. That means this topic would be one future work. Since the existence of a large number of data centers in the city, solar PV would be the best choice as energy source. The power can be delivered directly to DC bus without any conversion system. However, filtering the power path and energy storage for overnight utilizing would be technical barriers. On the other hand, fuel cells can replace UPS in existing data center power distribution system because they are free of charging as renewable source. Finally, the data center power distribution system will have little operation electricity cost when renewable energy is applied.

## Chapter VI Conclusion

Conventional electrical power distribution system of data centers are based on large scale of AC transformer, AC UPS and PDU power conversions in an extremely low efficiency.

The Proposed 380V DC Power Distribution System utilized centralized AC to DC converters with high efficiency DC UPS and non-transformer PDU through Busway Distribution, brought a considerable improvement on system efficiency and power requirement. The main contributions of this paper can be summarized as follows:

- Applied the Buck-type Current Source Rectifier as the Centralized Power Converter, and through Simulation to verify the feasibility of this solution under variable loads conditions.
- According to analyzing the existing data center architecture, selected the best suitable power distribution equipment and approach for this DC System.
- Through the calculation and comparison of power losses, power requirement and efficiency (PUE), obtained a completed and successful electrical efficiency modeling of The Proposed DC Power Distribution System.

This compensative design significantly provided an efficient approach on the topic of Data Center Power Distribution, in order to achieving higher efficiency, this research will go on.

## References

- [1] R. Brown et al. "Report to Congress on Server and Data Center Energy Efficiency Public law 109-431," U.S.Environmental Protection Agency ENERGY STAR Program, August 2, 2007.
- [2] Rasmussen, Neil. "AC vs. DC Power Distribution for Data Centers." *American Power Conversion, Tech. White Paper 63* (2007).
- [3] Rasmussen, Neil. "High-Efficiency AC Power Distribution for Data Centers." *American Power Conversion, Tech. White Paper 128* (2007).
- [4] Rasmussen, Neil; James Spitaels, "A Quantitative Comparison of High Efficiency AC vs. DC Power Distribution for Data Centers." *American Power Conversion, Tech. White Paper 127* (2007).
- [5] Rasmussen, Neil. "Review of Four Studies Comparing Efficiency of AC and DC Distribution for Data Centers." *American Power Conversion, Tech. White Paper 151* (2007).
- [6] Rasmussen, Neil; Torell Wendy, " Comparing Data Center Power Distribution Architectures." *American Power Conversion, Tech. White Paper 129* (2007).
- [7] Rasmussen, Neil, "A Scalable, Reconfigurable, and Efficient Data Centers Power Distribution Architecture." *American Power Conversion, Tech. White Paper 129* (2007).
- [8] Hu Pearl, "Electrical Distribution Equipment in Data Center Environments." *American Power Conversion, Tech. White Paper 61* (2007).
- [9]<http://powerquality.eaton.com/Products-services/Power-Distribution/Power-Distribution.asp>. Access date: 03/06/2014.
- [10] Rasmussen, Neil, "Electrical Efficiency Modeling for Data Centers." *American Power Conversion, Tech. White Paper 113* (2007).
- [11] Rasmussen, Neil, "Implementing Energy Efficient Data Centers." *American Power Conversion, Tech. White Paper 114* (2007).

- [12] Rasmussen, Neil, "An Improved Architecture for High-Efficiency, High-Density Data Centers." *American Power Conversion, Tech. White Paper 126* (2007).
- [13] Gyarmati, László, and Tuan Anh Trinh. "How Can Architecture Help to Reduce Energy Consumption in Data Center Networking?" *Proceedings of the 1st International Conference on Energy-Efficient Computing and Networking*. ACM, 2010.
- [14] "Converter Assessment for Data Center DC Power Distribution." Eaton GRT, Technology Discovery, 2013.
- [15] Stupar, A.; Friedli, T.; Minibock, J.; Kolar, J.W., "Towards a 99% Efficient Three-Phase Buck-Type PFC Rectifier for 400-V DC Distribution Systems," *Power Electronics, IEEE Transactions on*, vol.27, no.4, pp.1732,1744, April 2012.
- [16] Krstic; Familant; Bhavaraju; Lui; Theisen; Nasiri, "Data Center Power Distribution," Eaton. May 10, 2012.
- [17] Nussbaumer, T.; Kolar, J.W., "Advanced modulation scheme for three-phase three-switch buck-type PWM rectifier preventing mains current distortion originating from sliding input filter capacitor voltage intersections," *Power Electronics Specialist Conference, 2003. PESC '03. 2003 IEEE 34th Annual* , vol.3, no., pp.1086,1091 vol.3, 15-19 June 2003.
- [18] Baumann, M.; Kolar, J.W., "Comparative evaluation of modulation methods for a three-phase/switch buck power factor corrector concerning the input capacitor voltage ripple," *Power Electronics Specialists Conference, 2001. PESC. 2001 IEEE 32nd Annual*, vol.3, no., pp.1327,1332 vol. 3, 2001
- [19] Nussbaumer, T.; Baumann, M.; Kolar, J.W., "Comprehensive Design of a Three-Phase Three-Switch Buck-Type PWM Rectifier," *Power Electronics, IEEE Transactions on* , vol.22, no.2, pp.551,562, March 2007.
- [20] Wei Zhang; Yanze Hou; Xinbo Liu; Yuanjun Zhou, "Switched Control of Three-Phase Voltage Source PWM Rectifier Under a Wide-Range Rapidly Varying Active Load," *Power Electronics, IEEE Transactions on* , vol.27, no.2, pp.881,890, Feb. 2012.
- [21] Annabelle Pratt; Corporate Technology Group, Intel; "DC Voltage Level Overview,"

July 2007.

[22] Rasmussen, Neil, "The Different Types of UPS Systems." *American Power Conversion, Tech. White Paper 1* (2007).

[23] [http://www.cisco.com/c/dam/en/us/solutions/collateral/borderless-networks/advanced-services/cisco\\_hp\\_server\\_pc\\_accuracy.pdf](http://www.cisco.com/c/dam/en/us/solutions/collateral/borderless-networks/advanced-services/cisco_hp_server_pc_accuracy.pdf) Access date: 05/11/2014.

[24] Rasmussen, Neil, "Guidance for Calculation of Efficiency (PUE) in Data Centers." *American Power Conversion, Tech. White Paper 158* (2007).

[25] Richard Sawyer, "Calculating Total Power Requirements for Data Centers." *American Power Conversion, Tech. White Paper 3* (2007).