



# Project Hummingbird: Recovery of a Rocket Using Autorotation

Karen Maurer, John Dennehy, Andrew Valenti, Sophie Zaccarine, James Le  
ERFSEDS, Embry-Riddle Aeronautical University

## Abstract

Project Hummingbird is an undergraduate research project with the goal of launching and recovering a sounding rocket using a rotor-recovery system that will safely guide the rocket to landing. It aims to demonstrate an alternative approach to current methods of booster recovery that would, like the other techniques, reduce the cost per launch, but would also require a less complex system and far less fuel.

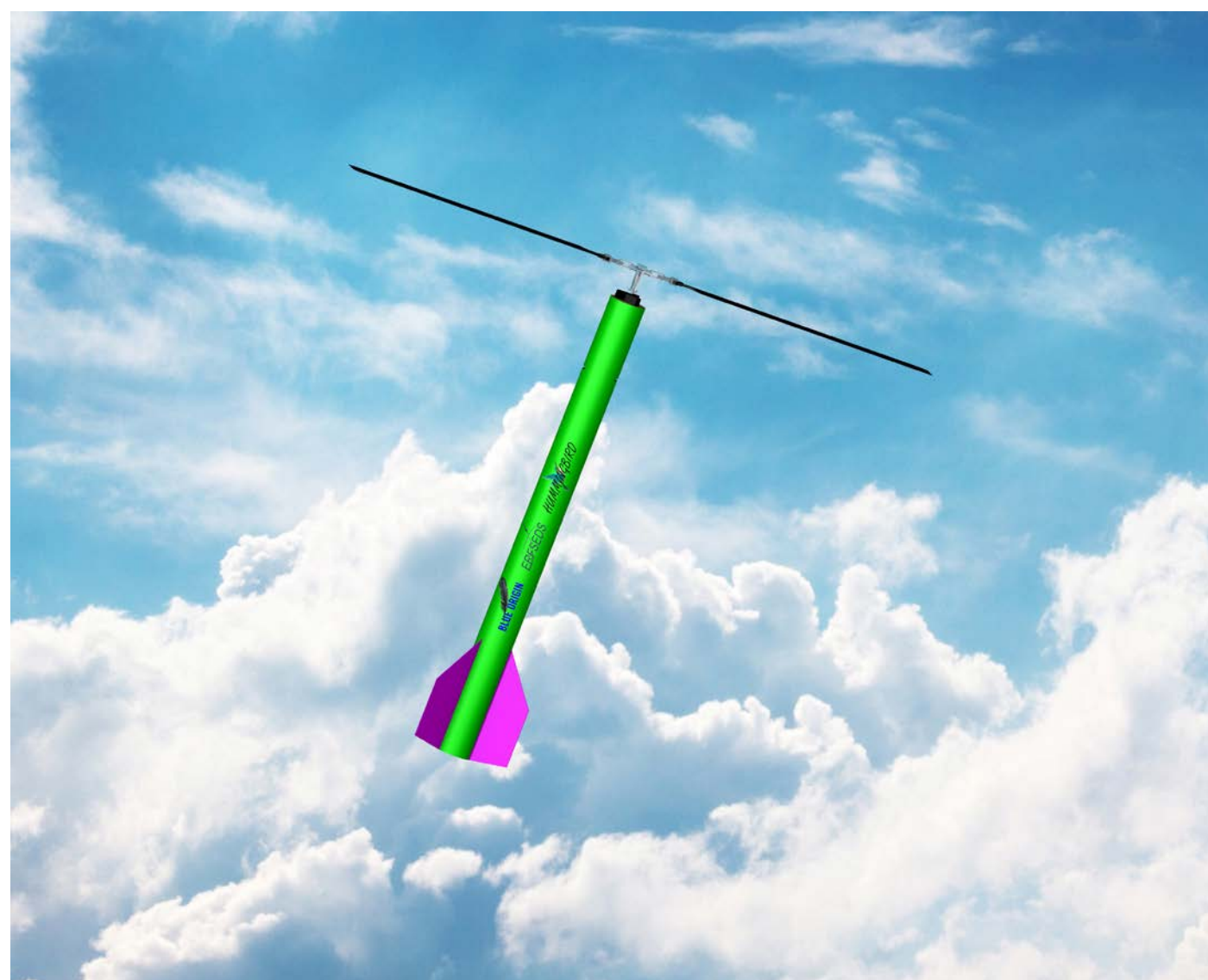

Figure 1. Rendering of Vehicle

## System Requirements

- Launch to an altitude high enough to test the experimental recovery system (not below 2700m)
- Retain blades to the rocket during upward flight
- “Right” rocket to proper upward orientation at apogee
- Deploy rotor blades
- Slow rocket descent to 6 m/s at landing
- Perform a flare movement just prior to landing
- Land at a pre-programmed location
- Sense whether the rocket has properly slowed
- Deploy an emergency parachute capable of slowing the rocket if rotor blades have not slowed descent
- Carry a flight computer capable of accepting inputs from an altimeters and IMUs and sending signals to control rotor servos, emergency parachute deployment, and any other systems requiring signals
- Transmit GPS data from all parts of rocket that land separately
- Maintain structural integrity during all flight tests

## Timeline

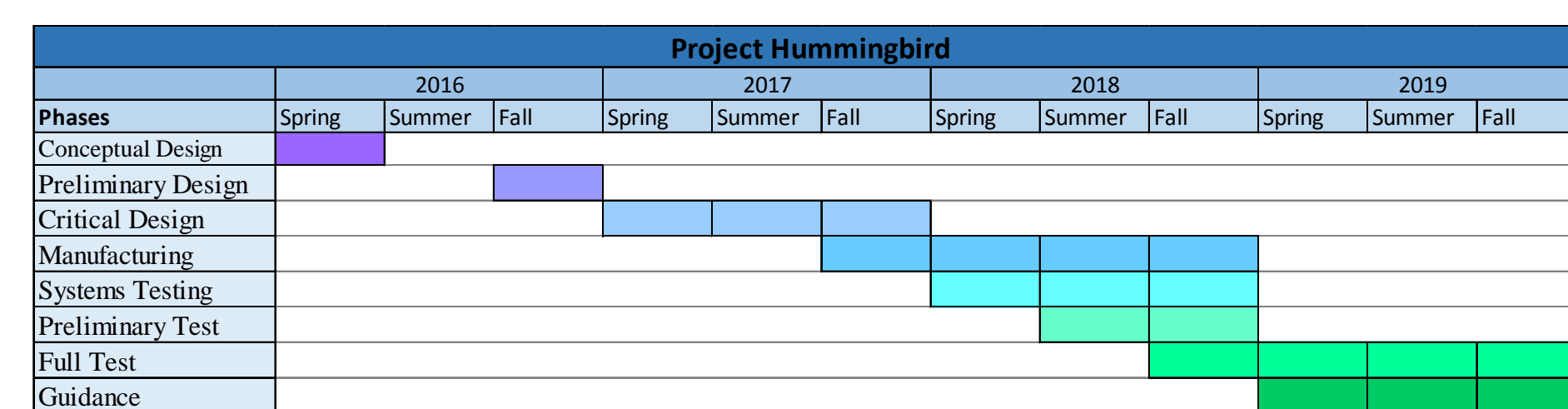

Figure 2. Gantt Chart of Project

## Concept of Operation

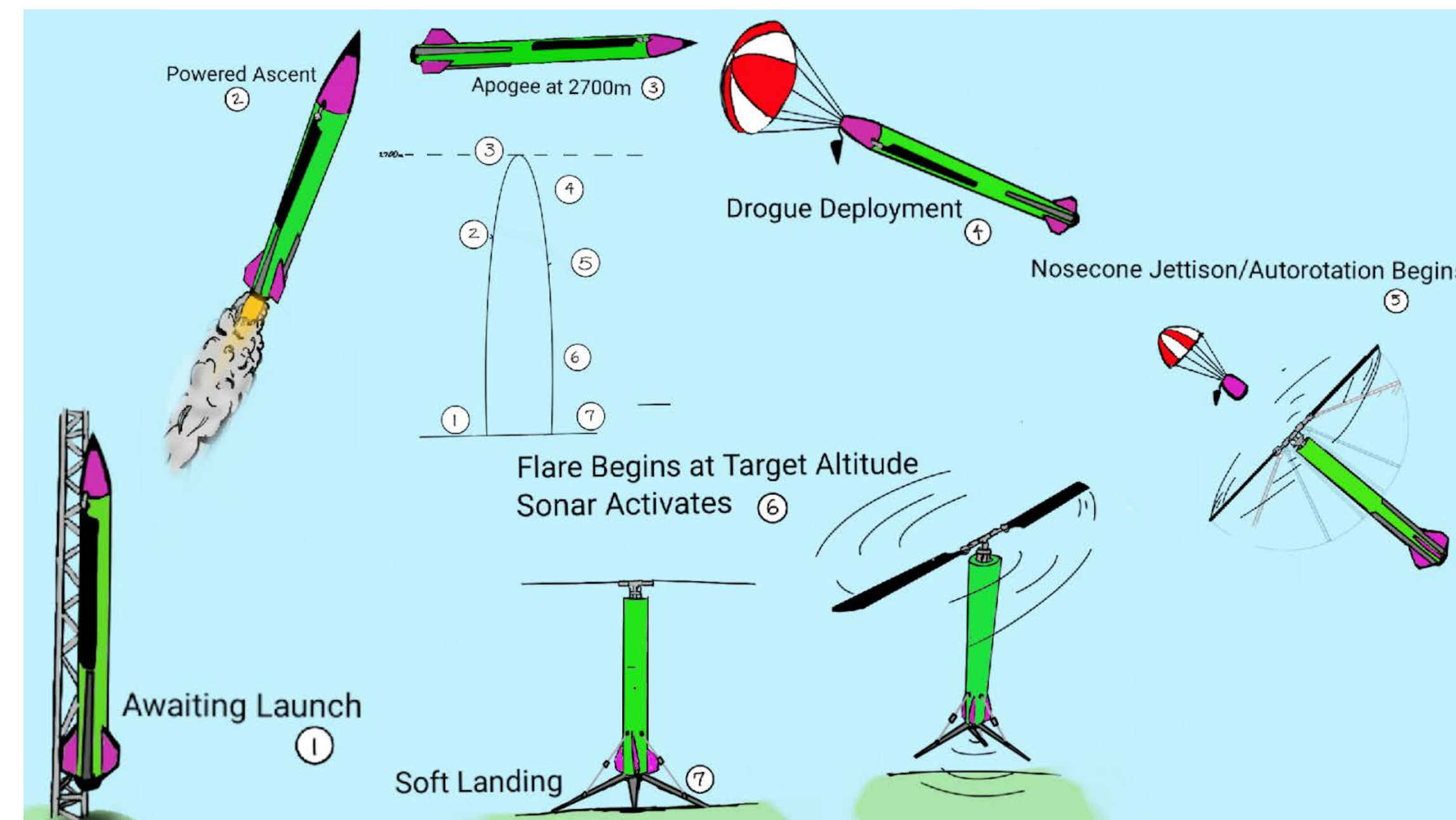

Figure 3. CONOPS

The system is designed to launch to 2,7000m with an internally stored rotor-hub and externally folded rotor-blades. At apogee, the rocket will deploy a small parachute out of the tip of the nosecone to orient itself nose up. Once the rocket is properly oriented, the entire nosecone will completely deploy off. The rotor-blades will deploy immediately after nosecone deployment. The rotor-blades will auto-rotate and slow the rocket's descent. Near the ground the rotor will perform a flare movement and land softly. An onboard flight computer will control the guidance and descent of the rocket to the ground. If the rotor-blades do not slow the descent of the rocket, an emergency parachute will deploy.

## Autorotation/Rotor Blade Design

Hummingbird's recovery system utilizes autorotation to maintain a controlled descent. Autorotation is a behavior that pertains to unpowered rotor blades with airflow traveling through the blades from the bottom as opposed to the top. This changes the effective angle of attack of the blades so the lift vector has a forward component to drive the rotor for sections of the blades. This will reach a dynamic equilibrium and settle to a steady RPM storing angular momentum. This stored momentum can be utilized to decelerate the body at landing.

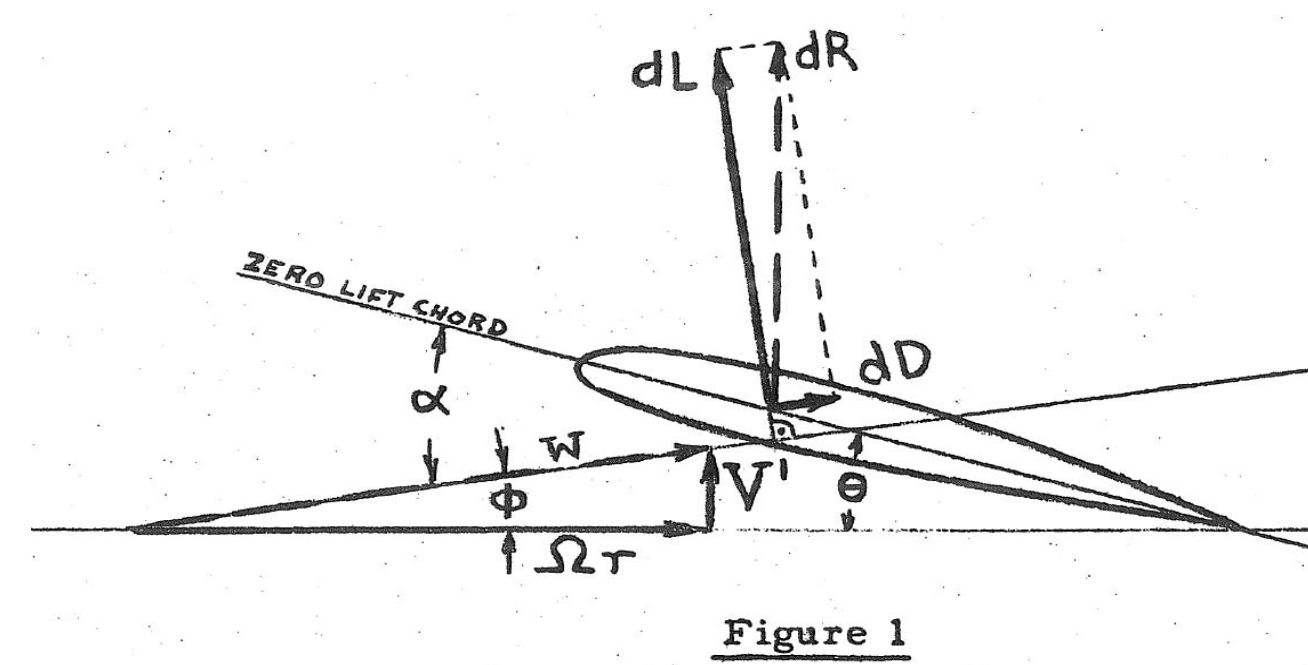

Figure 5. Autorotational Blade Forces

With this newfound information, the project focus was shifted from modeling the rocket in a simulation to collecting experimental data through test and development. A scale model is being designed to be used for wind tunnel testing and initial drop testing. The wind tunnel testing will find different conditions that autorotation will occur at for dynamically similar blades.

## Hub and Blade Grips

The full scale Hummingbird vehicle will use an HP2S rotor head manufactured by Goblin Helicopter. This rotor head is made specifically for high performance remote controlled helicopters that use rotor blade lengths range from 700-770mm. The rotor head can be fitted with servo motors and powered to change the pitches of the blades if needed. In order to deploy the rotor blades and hold them in the deployed position, a custom hinge adapter had to be designed. This hinges fits into the blade grips of the rotor head and allows the blades to fold and align to the rocket's airframe. To hold the blades up after deployment, the hinge assemblies have torsion springs that keep the assembly from folding downward.

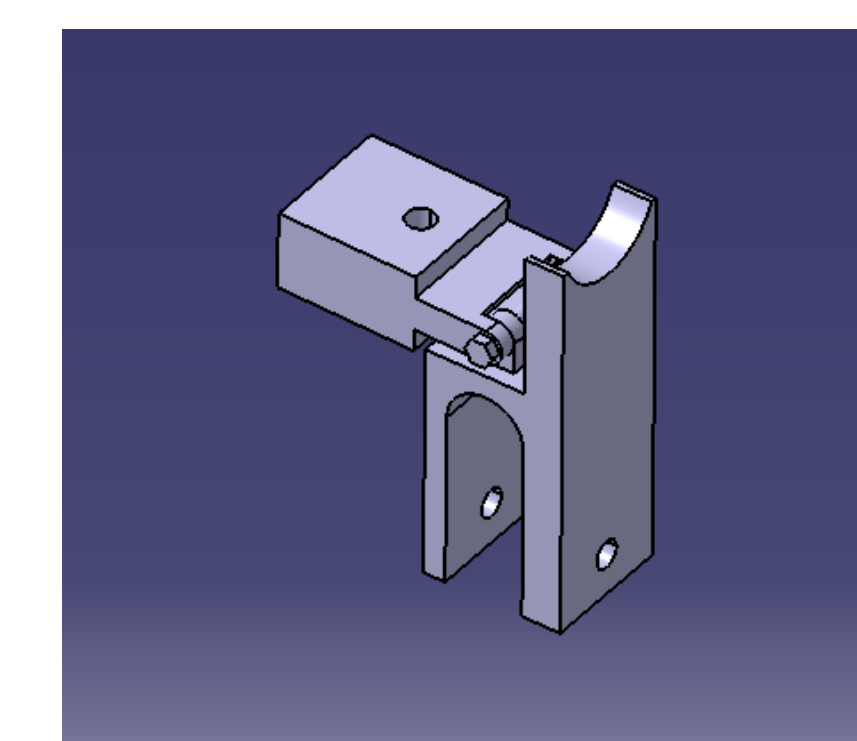

Figure 6. Hinged Blade Grip

## Nosecone Deployment System

The nose cone contains a 24" drogue chute attached to a U-bolt within its topmost chamber, which extends from the tip to the forward bulkhead and is sectioned laterally. The chute deploys via a black powder charge at apogee, triggered by an altimeter which is taking constant readings of local static pressure. The middle chamber contains the avionics which include the altimeter (plus an identical altimeter for redundancy), two 9-volt batteries for each altimeter, a GPS tracker with LiPo battery, and a CO2 system with two cartridges. Each altimeter is wired separately to a button which is accessed via the static pressure vent ports on the side of the nose cone. The rear bulkhead is removable and sealed to the inside walls with a silicone gasket, which provides the space below the rear bulkhead with the necessary pressure from the CO2 discharge (triggered by the altimeter) to separate the nose cone from the rocket body.

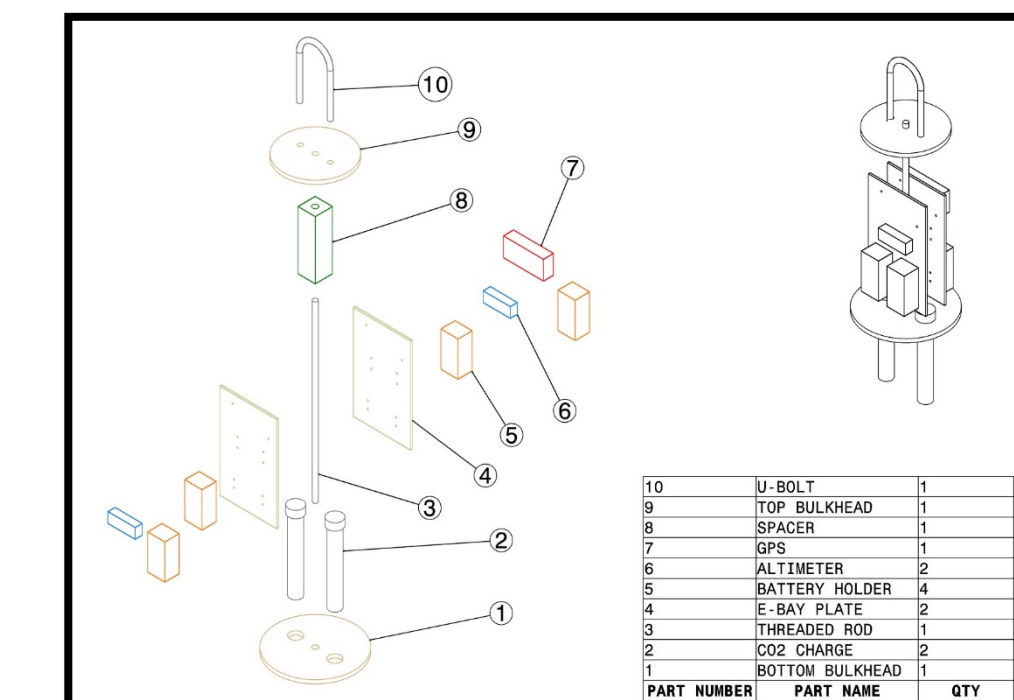

Figure 7. Nosecone Avionics

## Electronics

The job of the Hummingbird Electronics is to deploy the blades and stabilize the rocket during decent. We are using an Odroid C2, a powerful single board computer, as our flight computer. The job of the flight computer is to read the orientation data from our 9-axis IMU and altitude data from our two onboard altimeters. The Odroid will then control the movements of three servos connected to the rotor head assembly. These servos control the angle of the blades, which will intern, determine the orientation of the descending rocket. A secondary job of the flight computer is the initiate an emergency sequence if the blades fail to slow the rocket during decent.

## Rocket Airframe

The rocket airframe is 1.93m in length and 13.97cm in diameter. The airframe is made entirely of student manufactured fiberglass composite tubes. The rocket will be launched on a Cesaroni M-795 motor.

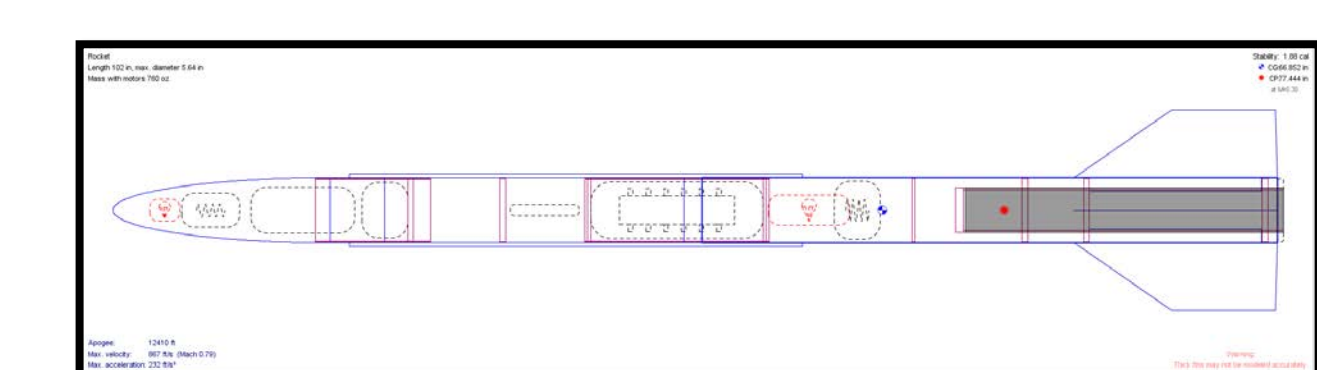

Figure 8. OpenRocket Model