

3-1992

The Influence of Cross-Cultural Differences on the Interpretation and Understanding of Aircraft Passenger Safety Briefing Cards

Florian G. Jentsch

Embry-Riddle Aeronautical University - Daytona Beach

Follow this and additional works at: <https://commons.erau.edu/db-theses>



Part of the [Management and Operations Commons](#)

Scholarly Commons Citation

Jentsch, Florian G., "The Influence of Cross-Cultural Differences on the Interpretation and Understanding of Aircraft Passenger Safety Briefing Cards" (1992). *Theses - Daytona Beach*. 274.

<https://commons.erau.edu/db-theses/274>

This thesis is brought to you for free and open access by Embry-Riddle Aeronautical University – Daytona Beach at ERAU Scholarly Commons. It has been accepted for inclusion in the Theses - Daytona Beach collection by an authorized administrator of ERAU Scholarly Commons. For more information, please contact commons@erau.edu.

**THE INFLUENCE OF CROSS-CULTURAL
DIFFERENCES ON THE INTERPRETATION
AND UNDERSTANDING OF AIRCRAFT
PASSENGER SAFETY BRIEFING CARDS**

by
Florian G. Jentsch

A Thesis Submitted to the
School of Graduate Studies and Research
in Partial Fulfillment of the Requirements for the Degree of
Master of Aeronautical Science

Embry-Riddle Aeronautical University
Daytona Beach, Florida
March 1992

UMI Number: EP31848

INFORMATION TO USERS

The quality of this reproduction is dependent upon the quality of the copy submitted. Broken or indistinct print, colored or poor quality illustrations and photographs, print bleed-through, substandard margins, and improper alignment can adversely affect reproduction.

In the unlikely event that the author did not send a complete manuscript and there are missing pages, these will be noted. Also, if unauthorized copyright material had to be removed, a note will indicate the deletion.

UMI[®]

UMI Microform EP31848
Copyright 2011 by ProQuest LLC
All rights reserved. This microform edition is protected against
unauthorized copying under Title 17, United States Code.

ProQuest LLC
789 East Eisenhower Parkway
P.O. Box 1346
Ann Arbor, MI 48106-1346

Florian G. Jentsch © 1992
All Rights Reserved

**THE INFLUENCE OF CROSS-CULTURAL DIFFERENCES
ON THE INTERPRETATION AND UNDERSTANDING OF
AIRCRAFT PASSENGER SAFETY BRIEFING CARDS**

by

Florian G. Jentsch

This thesis was prepared under the direction of the candidate's thesis committee chairman, Dr. Charles Richardson, Department of Aeronautical Science, and has been approved by the members of his thesis committee. It was submitted to the School of Graduate Studies and Research and was accepted in partial fulfillment of the requirements for the degree of Master of Aeronautical Science.

THESIS COMMITTEE



Dr. Charles Richardson
Chairman

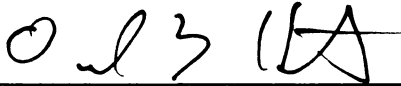

Mr. Donald Hunt
Member

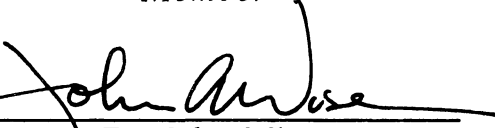

Dr. John Wise
Member

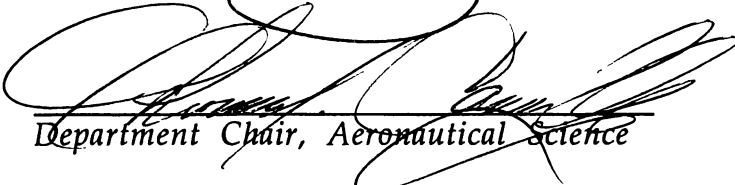

Department Chair, Aeronautical Science



Dean, School of Graduate Studies and Research

3/31/92
Date

ACKNOWLEDGEMENTS

I am thankful and in debt to a number of people who supported me while preparing this thesis. Special thanks go to the members of my thesis committee, Dr. Charles Richardson, Mr. Donald Hunt, and Dr. John Wise. Without their encouragement, knowledge, critique, and patience, this thesis would not have been possible. I feel lucky to have had such fine teachers and researchers on my committee.

At universities in five countries, people made this thesis possible through administering tests for me. I am grateful to Monsieur Michel Andreu from the French École Nationale de l'Aviation Civile, Toulouse, Prof. Gianni Casale from the Intitué Don Bosco, Warcoing, Belgium, Dr. Jake Empson from the University of Hull, United Kingdom, Dr. Daniel Garland from Embry-Riddle Aeronautical University, Daytona Beach, Florida, Herrn Prof. Dr. Gerhard Hüttig, Herrn Wolfgang Busch, and Frau Petra Göbel from the Technical University of Berlin, Germany, Dr. Helen Muir from Cranfield Institute of Technology, United Kingdom, and Mr. Mike Sylvester, St. Leo's College and Embry-Riddle Aeronautical University.

Here at Embry-Riddle, Mrs. Janet Kappa from the Jack R. Hunt Memorial Library never hesitated to devote a special effort towards supplying me with all the needed literature. Dr. Owen Lee supported me with my literature search. Thanks to them, again.

Last, but definitely not least, I would like to express my thanks and gratitude to my parents and to my friends here and there without whose support there would not be a thesis. Thanks, Mom and Dad, thanks Christof, Dave, John, Martin, Pat, and Yves!

ABSTRACT

Author: Florian G. Jentsch
Title: The Influence of Cross-Cultural Differences on the Interpretation and Understanding of Aircraft Passenger Safety Briefing Cards
Institution: Embry-Riddle Aeronautical University, Daytona Beach, Florida
Degree: Master of Aeronautical Science
Year: 1992

Aircraft passenger safety briefing cards are an important part of passenger safety education aboard commercial aircraft. The cards must be understood by all readers, regardless of age, gender, or culture. Related research indicates that passengers from different cultures might misunderstand the highly specialized instructions on safety cards.

A self-developed test was administered to 172 students from four cultures (British, French, German, U.S.) at seven universities in five countries. Significant differences ($p < 0.05$) according to culture were found for the interpretation of pictograms. Culture did also significantly influence the understanding of the color designating emergency exits in airplane floor lighting ($p < 0.01$). European subjects selected green, while subjects from the U.S. chose red. Although significant differences were found in the design preferences for safety cards, these differences were not as hypothesized. The results indicate that the interpretation of safety information varies between cultures. Appropriate recommendations were made.

TABLE OF CONTENTS

Abstract.....	v
List of Tables.....	x
List of Figures.....	xi
List of Abbreviations.....	xiv
Introduction.....	1
The Accident Record.....	1
Survival of Aircraft Accidents.....	1
Passenger Safety Education.....	2
Advantages of Passenger Briefing Cards.....	4
Understanding of Safety Cards.....	5
Statement of the Problem.....	6
Review of the Related Literature.....	7
Benefits of Passenger Safety Briefing Cards.....	7
Previous Studies of Safety Card Designs.....	8
Current Aircraft Passenger Information Cards.....	12
Safety Card Sample.....	13
Cross-cultural Communication.....	18
Cross-cultural Studies on Communication.....	21
Americans, British, French, and Germans: General Cultural Differences in Communication Styles.....	23
Americans, British, French, and Germans: Differences in the Use of Technical Signs.....	26
Summary.....	27
Statement of the Hypotheses.....	28

Method.....	31
Subjects.....	31
Native Language and Field of Study.....	31
Age.....	33
Gender.....	33
Previous Flight Experience.....	35
Instrument.....	36
Description.....	36
Development and Features.....	38
Test Instructions.....	44
Design.....	45
Limitations.....	46
Procedure.....	48
Pilot Tests.....	48
Administration of the Tests.....	49
Analysis.....	51
General Approach.....	51
All Subjects.....	52
Highly Stratified Subgroup.....	52
Control Tests.....	53
Safety Card Design Features.....	54
Description.....	54
Drawings as a Design Feature.....	57
Worded Instructions as a Design Preference.....	60
Photos as a Feature in the Design of Safety Cards.....	62
Color-Coding of Exit Lights.....	64

Interpretation of Pictograms.....	68
Approach.....	68
Categorizations.....	70
Results.....	81
Other Influences on the Interpretation of Safety Cards.....	93
Summary.....	94
Brief Comparison of the the Overall Effectiveness of the	
Pictograms	95
Exit Lighting.....	96
High Heel Shoes.....	97
Exit Slides.....	98
Electronic Equipment.....	99
Conclusions.....	100
Interpretation of Pictograms.....	101
Safety Card Design Preferences	103
Color Coding of Exits in Floor Lighting.....	103
Summary.....	105
Recommendations	107
General Recommendations.....	107
Recommendations for Test Procedures.....	108
Recommendations for Safety Card Design.....	109
Recommendations Regarding Specific Pictograms.....	110
Recommendations Regarding Exit Path Lighting.....	111
References.....	115

APPENDIX A:	FAR Part 121.571 and FAR Part 121.585 (d) and (e).....	119
APPENDIX B:	FAR Part 135.117 and FAR Part 135.129 (d) and (e).....	122
APPENDIX C:	Safety Card Sample - Data	125
APPENDIX D:	English Test/Questionnaire	128
APPENDIX E:	Test/Questionnaire: French Version	136
APPENDIX F:	Test/Questionnaire: German Version.....	144
APPENDIX G:	FAR Part 91.21.....	152
APPENDIX H:	Pictograms and their Sources.....	154
APPENDIX I:	Test Instructions in English, French, German	158
APPENDIX J:	Test Results for the 13 Pictograms.....	162

LIST OF TABLES

1. Safety Cards in the Sample. Number of Cards by Aircraft Type. Jet Aircraft only	14
2. Safety Cards in the Sample. Number of Operators Represented by Aircraft Type and by Region. Jet Aircraft only.....	14
3. Age Distribution by Group	33
4. Gender Distribution by Group.....	34
5. Flight Experience by Group	35
6. First Design Choices in Percents by Country	55
7. Second Design Choices in Percents by Country	56
8. Third Design Choices in Percents by Country.....	56

LIST OF FIGURES

1. The Three Pictograms Representing Instructions to Remove High-Heel Shoes (HEELS1, HEELS2, HEELS3).....	41
2. The Three Pictograms Representing Information about Floor Exit Path Lighting (EXIT1, SMOKELIG, FLOORLIG).....	41
3. The Two Pictograms Representing Instructions for the Usage of Emergency Exit Slides (SLIDE1, SLIDE2).....	42
4. The Two Pictograms Representing the Prohibition to Use Certain Kinds of Electronic Equipment.....	42
5. Drawings as 1st, 2nd, and 3rd Design Choices for all Subjects. Percentage in Subjects by Country.....	58
6. Worded Instructions (Words and Multiple Languages) as 1st, 2nd, and 3rd Design Choices for all Subjects. Combined Percentage of Subjects by Culture	61
7. Photos as 1st, 2nd, and 3rd Design Choices for all Subjects. Percentage of Subjects by Culture.....	63
8. Color Coding of Exits in Floor Lighting. Indicated Current Method for all Subjects. Percentage of Subjects by Culture	65
9. Color Coding of Exits in Floor Lighting. Comparison of Red and Green as the Current Method for all Subjects. Percentage of Subjects by Culture	66
10. Color Coding of Exits in Floor Lighting. Indicated Preferred Option for all Subjects. Percentage of Subjects by Culture.....	66
11. Color Coding of Exits in Floor Lighting. Comparison of Red and Green as the Preferred Option for all Subjects. Percentage of Subjects by Culture	67

12. Example Given in the Test: "Do not Smoke Cigars or Pipes."	68
13. Pictogram 1 (EXIT1). Follow Floor Lights To Exit.....	70
14. Pictogram 2 (SLIDE1). Jump - do not sit.....	71
15. Pictogram 3 (HEELS1). Remove High-Heel Shoes.....	72
16. Pictogram 4 (OXYGEN). Oxygen Mask.....	73
17. Pictogram 5 (ELECTRO1). Do Not Use Certain Electronic Equipment	74
18. Pictogram 6 (HEELS2). Remove High-Heel Shoes.....	75
19. Pictogram 7 (SMOKELIG). Crawl Under Smoke and Follow Floor Marings	76
20. Pictogram 8 (SLIDE2). Jump - do not sit.....	76
21. Pictogram 9 (DITCH). In Case of an Emergency Landing on Water [to be followed by instructions]	77
22. Pictogram 10 (HEELS3). Remove High-Heel Shoes.....	78
23. Pictogram 11 (FLOORLIG). Colored Lights in the Floor Indicate an Emergency Exit	78
24. Pictogram 12 (ELECTRO2). Do Not Use Certain Electronic Equipment	79
25. Pictogram 13 (BUTANE). Do Not Use Butane/Gas Lighters	80
26. Cultural Differences in Interpreting Safety Card Pictograms. p-Values of Significance for all Subjects Using Chi-Square Tests.....	81
27. Interpretation of Pictogram 1 (EXIT1) for all Subjects. Percentage of Subjects by Culture	83
28. Interpretation of Pictogram 2 (SLIDE1) for all Subjects. Percentage of Subjects by Culture	84
29. Interpretation of Pictogram 5 (ELECTRO1) for all Subjects. Percentage of Subjects by Culture.....	86
30. Interpretation of Pictogram 7 (SMOKELIG) for all Subjects. Percentage of Subjects by Culture.....	88

31. Interpretation of Pictogram 12 (ELECTRO2) for all Subjects. Percentage of Subjects by Culture.....	83
32. Interpretation of Pictograms. Overall Mean Scores for all Subjects.....	95
33. Comparison of Mean Scores for Pictograms Showing Emergency Exit Floor Lighting. All Subjects, by Culture.....	96
34. Comparison of Mean Scores for Pictograms Showing Instructions to Remove High-Heel Shoes. All Subjects, by Culture.....	97
35. Mean Scores for Pictograms Showing Instruction of how to use the Emergency Exit Slides. All Subjects, by Culture.....	98
36. Mean Scores for Pictograms Showing the Prohibition to use Certain Types of Electronic Equipment. All Subjects, by Culture.....	99

LIST OF ABBREVIATIONS

A300	Airbus Industrie A300 Aircraft
A310	Airbus Industrie A310 Aircraft
A320	Airbus Industrie A320 Aircraft
B727	Boeing Model B727 Aircraft
B737	Boeing Model B737 Aircraft
B747	Boeing Model B747 Aircraft
B757	Boeing Model B757 Aircraft
B767	Boeing Model B767 Aircraft
CIT	Cranfield Institute of Technology
DC-9	McDonnell-Douglas Commercial DC-9 Aircraft
DC-10	McDonnell-Douglas Commercial DC-10 Aircraft
DHC-8	DeHavilland Canada DHC-8 (Dash-8) Aircraft
DoT	United States Department of Transportation
E-RAU	Embry-Riddle Aeronautical University
F100	Fokker F100 Aircraft
FAA	Federal Aviation Administration
FAR	Federal Aviation Regulation
IATA	International Air Transport Association
ICAO	International Civil Aviation Organization
MD-11	McDonnell-Douglas MD-11 Aircraft
MD-80/88	McDonnell-Douglas MD-80/88 Aircraft
NTSB	National Transportation Safety Board
SAE	Society of Automotive Engineers
TUB	Technische Universität Berlin (Technical University of Berlin)
UCF	University of Central Florida

Introduction

The Accident Record

Travel aboard commercial airliners has become the safest mode of transportation. Fatal injuries per passenger mile are 12 times less likely to occur during commercial air travel than when travelling by automobile. In the *United States alone*, some 50,000 people die each year in car-related accidents (Goldstein, 1990). Approximately 1,000 people are killed in various forms of air transportation in one year in the U.S., most of them (> 95%) in general aviation. The number of people killed in commercial aviation accidents *worldwide* varies between approximately 300 and 2,000 per year (Taylor, 1989). Large fatal accidents are rare in commercial air transportation. Thus, a single accident with many fatalities can significantly increase the number of people killed in a particular year.

To reduce the possibility of aircraft accidents even further, aircraft must pass a series of tests to ensure that their airframes, engines, and equipment are suitable for the aircraft's operations before being certified. Likewise, aviation personnel are trained and licensed in accordance with stringent rules and regulations. Procedures must be followed in every aspect of aviation to ensure safe and efficient air transportation. The focus in aviation, more than in any other mode of travel, is on safety. Yet, even the most sophisticated aircraft flown by the most experienced pilots have been involved in accidents, some of which were disastrous.

Survival of Aircraft Accidents

Although it is a common misconception within the public, most accidents of large jet airplanes and smaller commuter aircraft used by major

and regional airlines are *survivable*. In fact, in less than 14% of commercial aircraft accidents in the United States, somebody died (*fatal accidents*). The public perception was, however, that in 75% of airline accidents somebody aboard was killed (Barthelmes, 1985). According to the National Transportation Safety Board (NTSB), a *non-survivable accident* is one during which (a) the fuselage of the aircraft is substantially damaged, or (b) the impact forces exceed human tolerances, or (c) the seatbelts and seat-restraint systems do not properly secure the passengers. Still, during accidents that were categorized as *non-survivable*, passengers did survive.

If the majority of aircraft accidents are *survivable* and *non-fatal*, this means that passengers aboard an aircraft in most cases should be able to escape from an accident without fatal injuries or even without being physically harmed at all. Yet, many aircraft occupants who did survive the initial phases of an otherwise *survivable accident* unharmed were killed or severely injured by other subsequent factors. Passengers who were trapped inside an aircraft were killed by smoke inhalation, fire, or thermal exposure (Johnson, 1984). Thus, the means to successfully escape from an aircraft accident must be provided to the passengers. Emergency exits, exit slides, and life vests are only some of the required equipment installed in large commercial aircraft towards the goal of allowing aircraft occupants to survive after an initial accident.

Passenger Safety Education

No matter how sophisticated the equipment is, for it to be useful, passengers also must be able to use the provided hardware effectively. Yet, aircraft accident history shows that passengers exposed to emergency situations often were not able to perform the necessary survival tasks

correctly, e.g., donning life vests or oxygen masks, or opening emergency exits. Barthelmes (1985) cited one example in which only two of 53 passengers aboard a large commercial jet aircraft were able to don their oxygen mask correctly after a cabin depressurization occurred. It has, however, also been shown that passengers who were well-informed of emergency procedures and the use of emergency equipment were more likely to react in a correct and timely manner during an accident than uninformed aircraft occupants (e.g., Johnson, 1984). These findings can be explained by fundamental psychological principles which state that human behavior during emergencies is directed by two different methodologies (Johnson, 1980):

1. If people have learned how to answer an emergency beforehand, their response to that particular situation is less directed by conscious thinking than if the situation is new. Previously learned and practiced procedures are followed, leading to faster response times and lower error rates (Stewart-Morris, 1991).

2. If, however, the situation faced is unprecedented, people must develop a new set of rules to follow. This process can be very time consuming, and it implies the possibility of serious errors, especially under considerable stress such as in a life-threatening situation.

For the aforementioned reasons, passenger education regarding emergency procedures and the use of emergency equipment has become a vital part of safety precautions in commercial air transportation. In addition to oral briefings by crewmembers (i.e., flight attendants), video presentations, and placards, airlines are required by law (see Appendices A and B) to provide printed material to inform passengers of emergency procedures (Department of Transportation [DoT], 1992). This information is generally displayed on passenger safety information briefing cards which can usually be found in the

seat pocket in front of the passenger. The U.S. Federal Aviation Regulations (FARs) require these cards to be applicable only to the respective aircraft, and to show the location and operation of emergency exits and other related equipment (DoT, 1992).

Advantages of Passenger Briefing Cards

Unlike video presentations or crewmember briefings, the safety briefing cards are the only source of information available to the passenger at any time throughout the whole flight. Flight attendants are often occupied with other tasks, and video presentations usually are shown only once or, seldom, twice during a flight.

Most accidents occur during three critical phases of flight: during take-off and initial climb (23.5%), approach to land (45%), and landing (8%) (Lufthansa Jahrbuch, 1987). These statistics suggest that more than half of all aircraft accidents (53%) happen considerably after crewmember briefings or video presentations have been given. Long trans- and intercontinental nonstop flights frequently last up to 12 hours. In these cases, the time between the initial presentation of safety information and the point when this information needs to be recalled by a passenger during an approach or landing accident can be so long that many passengers might not be able to remember such information. This problem is aggravated by the fact that most aircraft passengers have no previous "hands-on" experience with the emergency equipment and procedures, whereas each crewmember of U.S. scheduled air carriers, for example, must perform the actual operation of emergency equipment at least once every 24 calendar months (DoT, 1992). If a passenger decided to review the safety information, the only source accessible at any moment would be the safety card. The cards, therefore, must be as

effective as possible, i.e., convey to the passengers in the fastest and least understandable way the information of how to perform the necessary tasks.

Understanding of Safety Cards

Current safety cards employ a variety of graphics technologies to transmit safety information to passengers. In addition to worded information, sometimes translated into several languages, pictorial display formats are used, such as photographs, drawings, or pictograms. According to the *Dictionary of Psychology* (Reber, 1985), a pictogram is "a picture or symbol used to represent an object or a concept" (p. 548). Thus, pictograms differ from realistic drawings in being substantially simplified (e.g., they omit all supplemental graphic information unnecessary to represent the object or concept). Pictograms, as well as photographs and languages, are only meaningful if the reader "recognizes a previously seen shape or has learned the signification of a conventional shape" (Bertin, 1983, p. 51). This symbolism involved in understanding the depicted safety information requires a certain amount of common previous experiences and knowledge among the passengers (e.g., in the recognition of pictograms).

A common core of experiences among aircraft occupants is difficult to assume, since today's air travel is truly international. In 1989, more than 1.1 billion passengers traveled on scheduled air carriers worldwide (Lufthansa Jahrbuch, 1990). Passengers come from many different countries even on domestic flights. The languages and cultural backgrounds of aircraft occupants are often extremely diversified. Yet, all passengers must be addressed when presenting safety information. Since safety briefing cards play an important role in passenger safety education, they must be

understood by every reader, regardless of age, previous experience, native language, or culture. The *Dictionary of Psychology* (Reber, 1985) defines the term "culture" as:

The system of information that codes the manner in which the people in an organized group, society or nation interact with their social and physical environment. In this sense the term is really used so that the frame of reference is the set of rules, regulations, mores and methods of interaction within the group. . . . each member must learn the systems and the structures (p. 170).

The graphics technologies employed on aircraft passenger safety cards require recognition of abstract information based on previous experiences or a previous frame of reference. Thus, questions arise whether interpretation and understanding of safety briefing cards are influenced by varying cultural backgrounds. Do two aircraft passengers from different countries who each speak a different language comprehend instructions in two separate ways because of their culture? If so, are the differences so great that they might constitute a danger to safety? Which symbols are universally recognized, and which are misunderstandable? Do people from various countries have different preferences of how information should be presented?

Statement of the Problem

The purpose of this study was to investigate how the information on passenger safety briefing cards is understood and interpreted by subjects from different cultural and geographical backgrounds. Several features of current aircraft safety cards were tested for their overall effectiveness among university students from Belgium, France, Germany, the United Kingdom, and the United States. The probable outcome of the subjects' answers in a real emergency was compared to their previous aviation experiences, their

gender, and their cultural background to determine whether culture has a significant influence on the understanding of briefing cards.

This study could serve as a basis for further investigation into cross-cultural aspects of passenger safety education. Areas to be studied could include differences in attention to safety presentations, or possible benefits of individualized video presentations in multiple languages.

Review of the Related Literature

Benefits of Passenger Safety Briefing Cards

There is a need to convey safety information to all occupants of commercial aircraft. The NTSB stated in 1974 that the percentage of passengers injured during mishaps who had not read the passenger safety briefing card was three times as great as that for those who had read the card (Altman, 1975a). Johnson (1972) found that inaction or wrong reaction after aircraft accidents were considerably lower among passengers who had received specific and understandable safety information. Additionally, passengers who were informed of the emergency exits and evacuation procedures were able to act according to a plan, leading to higher probabilities of survival after an aircraft accident. Pre-planning and quick action were important factors common to those passengers who survived major aircraft accidents, such as the runway collision at Tenerife in 1977 or the post-landing fire of a twin-jet in Cincinnati, Ohio, on June 2, 1983 (Barthelmes, 1985). In fact, Johnson (1984) cited several examples of passengers who attributed their survival solely to the fact that they had followed the pre-departure briefing and read the safety card.

Previous Studies of Safety Card Designs

Previous investigations into the effectiveness of aircraft passenger briefing cards focused exclusively on subjects from a single country, although the problem of educating passengers from different cultures had been recognized (Altman, 1974a; Edwards, 1990). The effectiveness of passenger safety briefing cards can be measured using different approaches. Johnson (1985), whose Interaction Research Corporation (IRCTM) has been designing about 50% of the safety cards aboard U.S. airliners (Brooks, 1986), has conducted regular studies regarding the effectiveness of briefing card designs. At IRC, safety cards were redesigned until a 90% level of understanding was achieved by subjects who were not continuously involved in air transportation (Lundstrom, 1988). Two basic methods for the test of safety card designs have been employed:

1. *Behavioral tests* investigate a subject's ability to perform a specific task after receiving safety information, e.g., donning oxygen masks after reading the respective part on a passenger safety briefing card. Although these tests carry a high validity, since they actually require a subject to *perform* the safety-related task, behavioral tests necessitate complex and somewhat time-consuming testing procedures. Only a limited sample of the population can be tested, and the tests are mostly restricted to a single task.

2. *Conceptual tests* are the more often used approach: Various designs and certain features of safety cards are shown by trained interviewers to test-participants who then attempt to interpret and verbally describe the depicted information. While conceptual tests do not require the subjects to physically execute the tasks depicted on the cards, they allow a substantially higher number of subjects to be tested over a greater variety of tasks.

Altman (1974b) used the behavioral approach to investigate the effectiveness of safety card designs on life jacket donning. The study was limited to U.S. subjects and revealed procedural problems with regard to the depiction of the various steps in life jacket donning. The findings were supported by Johnson, Blom, and Altman (1975) who investigated the effectiveness of video presentations on the same task of life jacket donning using the conceptual test method. It was concluded that nonverbal presentation of safety information yields considerable benefits over worded instructions when properly tested. In this study, age had no significant influence on the answers, while gender and previous flight experience did influence the amount of correct interpretations: Men did interpret the presented pictures more correct than women, and more experienced passengers also had an increased knowledge of safety procedures.

Johnson and Altman (1973) studied the influence of various safety card designs on passenger behavior when using emergency escape slides. The correct procedure of leaving an airplane via an emergency slide is to jump onto the slide instead of sitting down at the door and then sliding down the chute. Subjects received different instructions: With no briefing card, 59.9% of the subjects jumped onto the slide; with a briefing card instructing the passengers to jump, 67.8% did in fact jump, while the highest jump ratio (73.5%) was achieved when subjects received a briefing card telling the passengers to "jump don't sit" (p. 215). In a separate analysis of the data, no significant differences due to the subjects' gender were found.

Finnair, the state airline of Finland, conducted a conceptual test of a safety card before introducing the McDonnell-Douglas MD-11 into their fleet (Paajanen, 1991). To simulate naive subjects, 112 Finnish schoolchildren between the ages of 11 and 12 years were asked in open-ended questions to

answer in writing what they thought was meant by each presented part of the safety card. The design exclusively used drawings and pictograms. The results of the study supported earlier findings regarding the design of safety cards, such as the fact that the introduction of perspective correct drawings can be clarifying (Altman, Johnson, & Blom, 1970). Another outcome of the study was the finding that pictorial representations without any explanatory words could be misleading. Many children mistook the drawing of a uniformed flight attendant opening one exit, while a non-uniformed person opened a different exit, for a separation of doors available to passengers and crewmembers. Thus, if confronted with an emergency evacuation, these children would probably not use the exit depicted with the uniformed crewmember. This could lead to serious blockages, delays, and even the loss of lives.

In 1987, Schmidt and Kysor published the results of two studies which they conducted to investigate the appeal and effectiveness of safety briefing cards on U.S. students and government employees. The subjects, 10 human factors professionals and 15 regular commercial airline passengers were asked to rank 33 sample briefing cards in the order of their perceived effectiveness. While the highest-ranked cards used more pictures, more colors, and were comparably larger, they also used a minimum amount of words integrated with pictures. In addition to the first test, 25 government employees were given one card each and received an oral briefing. After the briefing was completed, the subjects had to answer specific questions regarding safety procedures to evaluate the effectiveness of the cards. Schmidt and Kysor concluded that those briefing cards which used sketches and drawings instead of photographs and that followed general recommendations were more effective than those which did not have these features. These results

corroborated with other research regarding aircraft passenger safety cards (e.g., Altman, Johnson, & Blom, 1970; Johnson 1984, 1985). Johnson (1980) recommended a detailed, pictorial, and four-colored card without photos. A photograph is less effective than a well-designed drawing, because the photo also shows unnecessary details, creating clutter and "visual noise" (Lundstrom, 1988, p. 39; Dwyer, 1967). Additionally, the cards should be independent from the reader's language or reading capability by using pictograms rather than words. Long and complicated sentences should be avoided and replaced by short instructions in basic English. "Omit reasons why, concentrate on procedures" (Schmidt & Kysor, 1987, p. 51). Altman, Johnson, and Blom (1970) preceded Schmidt and Kysor (1987) with a similar study: Twenty-two then-current passenger safety briefing cards were ranked in two separate tests by psychology students and human factors specialists according to their effectiveness. Edwards (1990) summarized the findings from these tests within the following guidelines for effective card design:

1. Pictures with a minimum of descriptive words alone are more acceptable than pictures alone, words alone, or pictures with a large number of descriptive words.
2. A realistic understandable picture of good quality is preferable to an abstract drawing.
3. Where a sequence of actions is called for, two or more numbered pictures are desirable.
4. A simple, uncluttered, systematically-organized card format enhances acceptance by the reader (p. 184).

Although none of the cited studies specifically addressed international subjects, one result from both behavioral and conceptual tests (e.g., Altman, Johnson, & Blom, 1970) was the recommendation of *culture free* methods of conveying safety information (Altman, 1975b). Basic guidelines for *culture free* techniques have been published by the International Air Transport Association (IATA) and the U.S. Society of Automotive Engineers (NTSB,

1985). The use of pictorial representations instead of worded instructions has been encouraged. Johnson, Blom, and Altman (1975) expressed their "hope that such information displays may be understood by people from all the major language groups in the world" (p. 107). If words were necessary to explain a fact or idea, the translation into several languages was recommended. These recommendations, however, are very limited and allow a considerable range of alternatives in the design of safety cards.

Current Aircraft Passenger Information Cards

In a 1985 safety study, the NTSB compared 80 different briefing cards from 13 U.S. airlines. It was concluded that already the U.S. cards varied significantly not only in form, size, and outer appearance, but also in the conveyed information. When comparing U.S. safety cards for their tests, Schmidt and Kysor (1987) distinguished five distinctively different card design methods, such as "mostly words," "words plus diagrams," "mostly diagrams," etc. (p. 54). Some authors (e.g., Schmidt & Kysor, 1987) attributed these differences to factors such as novelty to catch the readers' interest or the production of safety cards for specific audiences. The NTSB (1985) stated that a lack of standardization among the cards was also a result of the limited regulatory guidance with respect to passenger safety briefing cards.

In the U.S., Parts 91, 121, 125, and 135 of the Federal Aviation Regulations (FARs) govern the design and contents of safety cards (See Appendices A and B), together with the respective Advisory Circulars (ACs). The most stringent regulations regarding safety cards are stipulated by FAR 121.571 and the accompanying AC121-24A *Passenger safety information and briefing cards* (DoT, 1989). Yet, neither a standard format nor special testing of the cards are required. Additionally, no provisions have been made to

address non-English speaking passengers except for the recommendation that the use of international symbols is encouraged. In fact, after a new regulation came into effect limiting exit-row seating, some airlines incorporated this information on their cards by printing it solely in English, including the statement in the center of the card advising the – potentially illiterate or non-English speaking – readers that they should notify a crewmember and be reseated if "you do not read English well enough to understand the instructions on this card or do not understand oral crew commands in English" (Comair, 1990, p. 1).

Safety Card Sample

To get an overview of currently used aircraft passenger safety briefing cards, U.S. and international airlines were solicited at various airports in the U.S. and Europe for current safety card samples. Eighty-two cards from 29 airlines and aircraft manufacturers were collected. Of those 82 cards, 72 were applicable to large transport category jet aircraft. The other ten cards pertained to turbopropeller-driven commuter aircraft. Tables 1 and 2 show the origin of those cards pertaining to jet aircraft according to type, operator, and geographical area.

The sample taken was not intended to be statistically representative. Eleven U.S. airlines were contained in the group of jet aircraft operators. The ten represented European airlines came from France, Germany (3), Iceland, Luxembourg, the Netherlands, Portugal, Switzerland, and the U.K. Three airlines from Malaysia, Singapore, and Hong Kong were represented among the Asian operators. Further information about the cards in the sample can be found in Appendix C.

Table 1

Safety Cards in the Sample. Number of Cards by Aircraft Type.

Jet Aircraft only

Aircraft Type (Family)	Cards Total
<i>Airbus A300</i>	4
<i>Airbus A310</i>	6
<i>Airbus A320</i>	1
<i>Boeing B727</i>	14
<i>Boeing B737</i>	10
<i>Boeing B747</i>	8
<i>Boeing B757</i>	2
<i>Boeing B767</i>	4
<i>Fokker F100</i>	2
<i>Lockheed L-1011</i>	4
<i>McDonnell-Douglas DC-9</i>	11
<i>McDonnell-Douglas DC-10</i>	2
<i>McDonnell-Douglas MD-11</i>	2
<i>McDonnell-Douglas MD-80</i>	2
Total Different	72

Between the beginning of acquiring the cards and the preparation of the final copy of this study, two of the U.S. airlines included in the sample (Eastern Airlines® and Pan American®) ceased to operate. Two other U.S. airlines (TWA® and United Airlines®) changed the design of their safety cards considerably within this time frame, and their new cards were added to the samples.

Table 2

Safety Cards in the Sample. Number of Operators Represented by Aircraft Type and by Region. Jet Aircraft only

Aircraft Family and Type	Operators			Total
	U.S.	Europe	Asia	
<i>Airbus A300</i>	1	1	1	3
<i>Airbus A310</i>	2	2	1	5
<i>Airbus A320</i>		1	-	1
<i>Boeing B727</i>	8		-	8
<i>Boeing B737</i>	6	4	-	10
<i>Boeing B747</i>	1	4	2	7
<i>Boeing B757</i>	1	1		2
<i>Boeing B767</i>	2			2
<i>Fokker F100</i>	1	1		2
<i>Lockheed L-1011</i>	2			2
<i>McDonnell-Douglas DC-9</i>	5			5
<i>McDonnell-Douglas DC-10</i>	1	1		2
<i>McDonnell-Douglas MD-11</i>	1	1	-	2
<i>McDonnell-Douglas MD-80</i>	2		-	2
Total Different	11	10	3	24

All safety cards contained information about the location and operation of emergency exits, exit slides, and emergency exit lighting, as well as instructions regarding the use of supplemental oxygen and floatation devices (i.e., life vests or floatation cushions). The cards were sorted by the researcher according to their primary means of communicating safety information following the categorization proposed by Schmidt and Kysor (1985):

1. No cards used *mostly words*.
2. *Words plus diagrams* (i.e., drawings and pictograms) were the primary means of conveying information on 10 cards. All cards in this category came from a single U.S. operator (Delta Air Lines®).
3. Twelve cards used *words integrated with diagrams*. In contrast to the technique employed for the cards in category 2, these cards had descriptive texts directly incorporated into the drawings, not as a separate entry.
4. *Mostly diagrams* were found on 32 cards.
5. Instead of using diagrams, 18 cards used *photos*, sometimes *photos combined with text*. The cards from the sample that fell into this category originated from four U.S. air carriers (American®, Eastern®, Northwest®, and United®) and one European airline (Swissair®).

Sixty-eight cards in the sample used color to convey safety information (i.e., the use of color was not restricted to the frame on the card or the airline's logo), while four cards (all from Northwest Airlines®) were monochrome. Multiple languages were found on 48 cards from 16 airlines. Only 12 airlines, however, used different languages to transmit safety information. In all other cases, the designation of the card was the only part translated into different languages.

As indicated earlier, several airlines changed the design of their cards during the collection of the sample. However, no clear trend could be determined: While one U.S. airline (United®) did change their design from photos to diagrams integrated with words, another U.S. airline (TWA®) changed it from mostly diagrams to photos. Lufthansa® German Airlines incorporated words into their previous design which had used diagrams only.

Further analysis of the cards revealed distinct differences in certain areas: Thirty-eight cards from 17 airlines were pertaining to over-wing exits with removable exit doors and offered an option of where to put the door once it was removed from the frame during an emergency evacuation. Of these 38 cards,

1. Eight cards from three airlines proposed to put the door *on the seats in the exit row*.
2. Eight cards from nine airlines favored to *throw the door outside* through the exit.
3. Nineteen cards from seven airlines advised the passengers to put the exit door *on the seats behind the exit row*.
4. Two cards from two airlines showed the door *in the row in front of the exit row*.
5. On one card, the exit door was placed *on a seat row adjacent to the exit row*.

Other significant differences were found between the instructions of whether to wear shoes during an emergency evacuation via the escape slides. The three German airlines represented in the sample required generally that shoes should be taken off. Thirty-eight cards from 16 airlines used depictions of high-heel shoes only. The rest of the cards (22 from five U.S. airlines) did not specify this area.

The lack of standardization among aircraft passenger briefing cards as found in the sample is aggravated on the international scale by different regulations in most countries. In Germany, for example, the guidelines require safety cards to inform about the location and operation of emergency exits and life preservers, as well as about the supplemental oxygen system, if it is installed (Bundesverkehrsministerium, 1987). No specifications,

however, are made regarding how the "appropriate . . . placards and printed instructions" ["geeignete Hilfsmittel in der Form von Hinweisschildern und gedruckten Anweisungen"] (p. 673) should be designed. Due to the actual differences in card design, the NTSB (1985) proposed additional research in the area of passenger safety education.

Cross-cultural Communication

While the question of cross-cultural communication of safety information has found comparably little attention for aircraft, it has been the focus in other areas of transportation. Airports, for example, make use of an international signage system for passenger guidance and information (Air Transport Association of America, Airport Operators Council International, & American Association of Airport Executives, 1985; Cook & Smith, 1980), using pictograms to convey information to people from various countries.

Effective communication and the understanding of information depend upon a common basis between the communicator (i.e., the person who wants to convey the information) and the receiver (i.e., the person for whom the information is intended) (Casse, 1981; DoT, 1977). A common basis can consist of shared experiences, the same language, etc. Such factors can usually be found among people who grew up and lived within the same culture (Schneller, 1989). If the sender and the receiver, however, come from different cultures, the probability of missed or failed communication is increased. In today's truly international air travel, where every place in the world can be reached by airplane within 36 hours, potential passengers come from very diversified cultural backgrounds and speak more than 2,800 languages (Collins, 1982). Thus, the passengers' common basis for successful communication is minimized.

The use of signs and pictorial representations to transmit ideas is part of *nonverbal* communication, in contrast to verbal communication which uses words and language. According to Morain (1987), nonverbal communication can employ body language, object language (e.g., signs, clothing), or environmental language (lighting, color, architecture). As has been stated earlier, the interpretation of pictograms and realistic drawings involves the process of symbolism. Combinations of shapes and/or color produce a meaningful pictorial representation only, if "one recognizes a previously seen shape or has learned the signification of a conventional shape" (Bertin, 1983, p. 51). Bertin concluded that the signification of a shape is never unmistakable:

Indeed, even the most recognizable shapes can suggest numerous meanings. A horse's head can just as easily correspond to a race track, a stable, a stud farm, a riding school, a bridal path, a horse butcher, a glue factory, a harness factory, a chess game, etc. The cross, "symbol" par excellence, allows students armed with bad maps to imagine New York as garnished with cemeteries: The fine black crosses of the cemeteries and the fine red crosses designating monuments are similar at first glance!

There is no universal shape signification. The meaning of a symbol becomes familiar to us only by habit; through the repetition of a similar situation. A shape can become a symbol only within a restricted domain, rigorously defined and previously familiar to the observer (p. 95).

Some symbols have a more universal signification than others. This is especially true for colors as symbols of natural objects: Throughout the world, human beings perceive red as a symbol of fire, blue for water, or green for vegetation. However, if they never experienced a natural phenomenon, such as ice or snow, people might not be able to interpret a picture of white mountains. Other color symbolisms, on the other hand, are strictly related to particular cultures. Death is symbolized by black in western societies, while

the respective color is white in parts of the orient. Exit signs in buildings are green in most parts of Europe, while they are red in the U.S., etc.

Thus, when using color and/or shapes as a code on symbols, it is mandatory to select pictorial representations which are constant and intuitively meaningful to potential readers. The purpose of a symbol is not fulfilled if its meaning changes easily with small changes in its connotation: "A shape can become a symbol only within a restricted domain, rigorously defined and previously familiar to the observer. However, we must recognize that modern information tends to mix different domains and hinder such familiarity!" (Bertin, 1983, p. 95) An aircraft floating on water, for example, can have two completely different meanings: When the symbol is used on a map, it most likely designates a *seaplane landing area*, while its meaning on a safety card is: *In case of emergency landing on water*.

The two different meanings of the plane on water are a typical case of what Schneller (1989) defined as "misunderstanding": "The addressee attributes a certain meaning rooted in his own individual pool of knowledge to the sender's signal or sign. But this meaning attribution differs, or even contradicts, the sender's intention when he/she encodes the message" (p. 467). Non-understanding, on the other hand, entails a lack of any connotation of a given signal, since the symbol does not exist in the receiver's knowledge. A misunderstanding can be more serious than non-understanding, since the receiver assumes to have correctly understood the message. Acting accordingly, the receiver might actually contradict the sender's intention. Parker (1988) noted that "illustrations can cause even more cultural problems than text. [Readers] . . . see illustrations immediately and react to them more strongly than to a written mistake buried in a thousands of words" (p. 1).

Cross-cultural Studies on Communication

Cultural differences were the focus of a study by the Institute for Defense Analyses (Sinaiko, Guthrie, & Abbott, 1969) regarding U.S. military and technical aid for the Republic of Vietnam. From previous studies, the authors concluded that there were "no inherent limits to the absorption of technical information and the acquisition of new skills" (p. 1) in any culture. Except for physical stature, culture was found to be learned, rather than biologically determined (Reber, 1985). Therefore, cultural differences were most pronounced in habit patterns, such as allocation of time, reluctance or wish to assume responsibility, or planning (or lack of it). Learning habits were found to vary according to cultural factors, e.g., the preference for learning by rote and imitation in some cultures. Therefore, standards of one culture for cross-cultural communication would not necessarily be applicable to another culture.

While cross-cultural differences in the understanding of verbal and body language have been widely demonstrated (e.g., Hall, 1977; Hall & Hall, 1990; Morain, 1987; Schneller, 1989), investigations into cross-cultural variances in the perception of pictorial material have been rather sparse. Miller (1973) reviewed previous research in the topic. Most of the cited studies were conducted by Europeans in Africa. In congruence with previous findings, Miller (1973) hypothesized that "cultural differences in responses to certain types of pictorial representations are reflections of differences in experiences with the techniques or conventions utilized in such representations, rather than differences in actual visual experiences in the three-dimensional world" (p. 136). Some subjects who lacked previous experience with photographs, for example, did devote the bulk of their attention on the geometrical contour and the white edges of a photograph

rather than focusing on the depicted object. "Once the individual is able to grasp the idea that a photograph or picture represents an object, he has learned to use one set of cues . . . to expect to see an object when presented with a picture" (Miller, 1973, p. 138). Yet, in another study cited by Miller, the subjects had more difficulty to recognize local, but unfamiliar animals from photos than familiar ones.

Mangan (1978) noted that the understanding and interpretation of pictorial representations was also dependent upon the extent to which a particular culture used graphics communication. In some traditional Islamic societies, for example, iconic representation was prohibited. Thus, it was concluded, it might be beneficially in some cultures not to use pictures at all to convey information. The perspective used to depict a certain object changed considerably among cultures, from the pseudo three-dimensional Western perspective, to a "fold-out" view showing all sides of an object in one picture, as used by some African and native American cultures. Other research cited by Mangan indicated that training and previous experiences allowed people to understand pictorial representations which were previously unfamiliar to them. An otherwise illiterate navigator from Micronesia was able to instantaneously understand a complicated U.S. navigational chart since his reference system (celestial objects) mirrored the one used for the production of the map. Mangan concluded that "visual images are far from self-explanatory. Accurate interpretation of such images involves the learning of conventions . . ." (p. 266). ". . . what one sees in a picture, will to a large degree depend on whether one's cultural environment (a) is in possession of pictures and (b) places emphasis on acquiring the ability to perceive what they depict" (p. 247).

To illustrate the problems caused by lack of previous experiences, Osborne (1987) cited Barnard and Marcel (1983) who employed the example of a penguin used to imply frozen goods. As Osborne pointed out, people who lacked previous experience with or had never seen a penguin might not be able to make the inferential connection between the symbol and the object it symbolized. In another study, Zambian children had more problems to identify a pig from a picture than Scottish children, while the opposite was true when the children were presented with a picture of a hippopotamus (Miller, 1973). Parker (1988) noted cultural sensibilities towards the use of certain illustrations. Gender and skin color of people, or certain animals depicted in graphics, were considered to be inappropriate or prejudiced according to cultural experiences. Thus, it was concluded that in order to effectively relay a certain message to receivers from different cultures, pictorial representations should be as unambiguous as possible and draw from a common core of previous experiences among the readers.

Americans, British, French, and Germans:

General Cultural Differences in Communication Styles

Although sharing a long common history and heritage, general cultural differences have been observed between the United States and Western Europe, as well as within Western Europe (e.g., Dreyfuss, 1970; Green & Pew, 1978; Hall & Hall, 1990; Heard, 1974; Lanier, 1973; Taylor, 1990):

Often Germans seem stiff and pompous to Americans while Americans seem sloppy and superficial to Germans. The French think Americans are enthusiastic but lacking in style; Americans feel the French take forever to get down to business. Germans think the French are not serious enough; the French think the Germans lack sophistication.

In fact, each country simply has its own way of seeing and doing things, based on unstated rules, and these hidden differences often make cooperation difficult. (Hall & Hall, 1990, p. xiii)

Hall (1977) introduced the concept of high- and low-context cultures.

In a high-context culture, much of the communication is rooted in long-standing traditions and takes place through unspoken hints, such as gestures. Thus, communication does not require a large amount of additional background data. Conversely, people from a low-context culture need as many additional information as possible to communicate. In a low-context culture, information is compartmentalized and not flowing freely from one person to another. Thus, the low-context person is accustomed to be provided with a large amount of background knowledge, from which the necessary information is derived: "High-context people are . . . apt to become impatient and irritated when low-context people insist on giving them information they don't need. Conversely, low-context people are at a loss when high-context people do not provide enough information (Hall & Hall, 1990, p. 9).

While the French are considered to be people of high context, Germans are supposedly the exact opposite (Hall & Hall, 1990); Americans and the British are considered to be between the two extremes, even if more towards the low-context side. Therefore, Germans want detailed information and need a highly-defined context when communicating. Communication must be well-defined, and Germans tend to take longer to convey a particular message than their French counterparts. This can be documented by the language and sentence structure in German: Words in German are generally more exact in meaning than for example in English (Hall & Hall, 1990). German writers always took pride in a long-sentenced and complicated style (e.g., Emmanuel Kant). Short sentences are regarded as simplistic in

Germany and as a sign of lacking writing capability. Each German noun has one of three different genders, and the articles and adjectives must conform. Germans must include extra accuracy in their verbal communication to satisfy the need for special information.

The French, on the other hand, do convey a large amount of information through non-verbal communication, such as body language (Taylor, 1990). Therefore, a personal appointment is much more appreciated in France than a telephone conversation or an impersonal letter (Hall & Hall, 1990). With the need for immediate human contacts comes an emphasis of style and form. The French are very focused on the correct and sophisticated use of their language, and are very articulate (Lanier, 1973).

Hall and Hall (1990) documented the variances in contexting by the form and contents of advertisements in France, Germany, and the U.S.:

German ads are loaded with detailed information; products are described and analyzed. . . . Ads are examined and picked apart . . . Good advertising strategies in Germany take into account that Germans are both print-oriented and very literal-minded. . . . print ads convey information rather than evoke a mood or appeal to subliminal emotions and desires. . . . The constant changes, the lack of continuity, the hyperbole and flamboyance [in U.S. advertising] – all puzzle and annoy [Germans] (p. 71 ff).

Germans ads, however, are often perceived as dull and boring – even by Germans themselves. Hall and Hall continued:

While the function of German advertising is to transmit information, the function of a French ad is to release responses – two entirely different functions. French advertising is high-context. It is based on product name recognition. . . . French ads are designed to be visually attractive and eye-catching. This fits the French visual orientation to life and reflects their sensitivity to aesthetics, color, and design. . . . An ad that is effective in the U.S. [, however,] will not necessarily be effective in France (p. 127f).

French advertisement does regularly win international prizes for artistic style and ingenuity, and samplers of French television ads are popular in German movie theaters for being entertaining – not for their marketing message.

U.S. advertisement is in marked contrast to the German idea of detailed information and the French preference for feelings.

Although ads in the United States may contain information, it is seldom detailed and is usually a bolster for the claims of product superiority. Exaggerated claims that a product is the best, newest, most fashionable, or finest are effective in the U.S. but would be both offensive and illegal in West Germany and would win no awards in France (Hall & Hall, 1990, p. 169).

As mentioned before, the British way of marketing communication is between the extremes. British advertisement can be extremely informative, yet it also can be of outrageous British black humor. Additionally, since U.S. advertisements do not need to be translated for the United Kingdom, the British are also exposed to a large amount of U.S. advertisement.

Americans, British, French, and Germans:

Differences in the Use of Technical Signs

As has been shown, one can distinguish between three distinct communication styles for France, Germany, and the U.S. Great Britain, yet distinct and deeply rooted in its own history, combines certain parts of the three styles, making it a well-defined reference point. Communication of marketing information varied considerably depending on culture. Germans, for example, preferred a wealth of printed information, while French readers chose advertisements which were focused more on graphics design.

The reviewed literature did not indicate that the influence of the three aforementioned communication styles on the interpretation and understanding of aircraft passenger safety cards has previously been

investigated. Considerable cross-cultural differences regarding the understanding of automotive symbols, however, have been found during tests in the U.S. and Western Europe (e.g., Dreyfuss, 1970; Green and Pew, 1978; Heard, 1974). Automobile transportation is comparable to air travel in several respects. Cars and aircraft were developed approximately at the same time. Both modes of transportation have given sets of technical and legal rules which are comparable in most countries in the world. Yet, the studies indicated distinct differences between British, French, German, and U.S. subjects regarding the use of highway and automotive signs. It was concluded from the tests that the interpretation of automotive symbols in Europe and in the U.S. varied considerably according to cultural traditions and local automotive standards set during the first 40 years of automobile development.

Collins (1982) summarized previous research in the use of symbols for highway signs, automotive and machinery applications, hazard warnings, as well as information symbols for buildings. Based upon findings such as that exit signs in buildings are red in the U.S. while they are green in France and Germany, the need for standardization and effective testing was emphasized, especially with regard to the increasing number of international travellers.

Summary

Aircraft passengers who are well-informed of safety procedures and the use of emergency equipment are more likely to survive an accident unharmed than uninformed occupants. Passenger safety information briefing cards are one method of conveying safety information to aircraft passengers. Current regulations, however, allow substantial differences between different safety cards. A sample of current safety cards revealed

distinct differences not only between the cards from different countries, but also between the cards from a single country.

Safety card designs that are using pictorial displays have been found to be more effective than those cards using worded instructions. However, even among cards solely using pictograms, considerable differences can be found. To understand a picture or symbol, a person needs to have learned the meaning of the symbol, or must have had previous experiences with the depicted object or concept. Traditions and cultural backgrounds can lead to differences in understanding pictorial information by users from different cultural backgrounds.

Three different communication styles were defined: The high-context French style conveys a large proportion of information through non-verbal channels with a preference for visual communication. Germans, being of very low context and thus on the other end of the spectrum, are very print-oriented and need considerable background information to successfully communicate. Americans, while being more low- than high-context people, are short and to the point. Although they can get bored by too much information, they hesitate to make decisions without a sufficient background. The British, while distinct, share characteristics with all three groups and can therefore serve as a reference point. Although the influence of these differences on the interpretation of aircraft passenger safety cards has not been studied before, previous investigations with regard to the use of symbols in buildings and cars revealed distinct differences.

Statement of the Hypotheses

Different cultures may use different symbols for depicting the same situation, process, or object (Dreyfuss, 1972). It was therefore hypothesized

that there are significant differences in the understanding and interpretation of current passenger safety briefing cards among subjects with different cultural backgrounds. It was also hypothesized that culture will have a stronger influence than gender, educational background, or previous flight experience. Based on the three previously defined communication styles, four detailed hypotheses were developed which state that individual cultural differences exist in the interpretation of safety cards between subjects from France, Germany, the United Kingdom, and the U.S. These cultural differences are more pronounced than the within-group differences such as gender or previous flight experience. The null-hypotheses for the following research hypotheses would always be: *There is no significant difference between cultures in this particular respect.*

Hypothesis I

Due to their low-context communication style, Germans prefer printed advertisements with detailed information. French advertisements are more focused on graphics, since the French are very sensitive towards color and design. It was hypothesized that, when being asked about their preferences in designing a safety card, French subjects indicate a higher preference for graphic stimuli such as drawings and color than German subjects who choose more worded instructions.

Hypothesis II

Photos were found to be used relatively widely on safety cards from the U.S. It was hypothesized that, when asked about their preferences on safety card design features, U.S. subjects indicate a significantly higher preference for photos than French, German, and British subjects.

Hypothesis III

Emergency exits are marked red in the United States and green in wide parts of Europe. It was hypothesized that, when asked about the colors used to denote aircraft emergency exits, European subjects choose green, while U.S. subjects choose red over other colors.

Hypothesis IV

The high-context French are strongly oriented towards visual stimuli. Germans with their low-context culture are supposed to be more susceptible to worded information. It was hypothesized that, when interpreting complex pictorial representations, the number of correct answers varies between subjects according to their culture.

Method

Subjects

One-hundred-and-seventy-two students were employed at seven universities in five countries. The students came from entire classes selected by local contacts (i.e., professors and teaching assistants) at the following universities:

1. Twenty students from the Intitué Don Bosco, Warcoing, Belgium (*Don Bosco*).
2. Nineteen students from the École Nationale de l'Aviation Civile, Toulouse, France (*ENAC*).
3. Fifty students from Technische Universität Berlin, Germany (*TU Berlin*).
4. Twenty-two students from the University of Hull, United Kingdom (*Hull*).
5. Twenty-four students from Cranfield Institute of Technology, United Kingdom (*Cranfield*).
6. Twenty-five students from Embry-Riddle Aeronautical University, Daytona Beach, Florida (*E-RAU*).
7. Twelve students from St. Leo's College, Daytona Beach Center (*St. Leo's*).

Since entire classes were selected for the tests, subjects whose native language differed from that of the country where their respective university was located were included in the test. These subjects were subsequently sorted into a special group, and their data were not used in the analysis.

Native Language and Field of Study.

The subjects came from five main groups based upon their native language with two subgroups each according to their field of study. Subgroups I (*Aero*) were complemented by students who studied in an aviation-related field (i.e., at ENAC, TU Berlin, Cranfield, and E-RAU), while

subgroups II (*Other*) consisted of students studying in a non-aviation oriented field, such as economics (TU Berlin), psychology (St. Leo's and Hull), or thermal technology and computer science (Don Bosco). The main groups were:

1. The *British group* consisted of 27 students who studied in England and indicated that their native language was English. Nine students studying air transport management at Cranfield (subgroup I) and 18 students studying psychology at Hull (subgroup II) were represented.
2. The *French group* was augmented by 37 subjects whose native language was French. Nineteen students were studying air transportation at ENAC (subgroup I), while 18 students studied thermal technology or computer science at Don Bosco (subgroup II).
3. All 49 students in the *German group* studied at TU Berlin and reported German as their native language. Subgroup I consisted of twenty-seven students in aeronautical engineering (*Luft- und Raumfahrttechnik*), while the 22 students in subgroup II studied economics (*Betriebswirtschaftslehre/Wirtschaftsingenieurwissenschaften*).
4. In the *U.S. group*, 37 U.S. students were represented whose native language was English. Twenty-five subjects studied in an aeronautical field at E-RAU, while the 12 subjects from St. Leo's studied psychology.
5. All students whose native languages were different from those spoken at the universities where they studied were assigned to the *International group*. These students studied at a university outside the area of their native language (e.g., Africans, Dutch, Germans, or French at Cranfield). Twenty-two students were sorted into this group. The data from these subjects were not used in the analysis.

Overall, 150 students complemented the *British* (27), *French* (37), *German* (49), and *U.S.* (37) groups. All further data and analyses are limited to the 150 students in those four groups.

Age

The students varied according to age. Of the 150 subjects, 20 (or 13.3%) were 30 years of age or older (one in the U.S. group was over 60), while 130 (or 86.7%) were under 30. Most (10) of the subjects who were 30 years of age or older came from the U.S. group, subgroup II. Table 3 shows the variations among the groups according to age.

Table 3

Age Distribution by Group

Group	Subgroup	under 30	Number over 30	Total
<i>British</i>	I (Aero)	6	3	9
	II (Other)	15	3	18
<i>French</i>	I (Aero)	17	2	19
	II (Other)	17	1	18
<i>German</i>	I (Aero)	27	0	27
	II (Other)	21	1	22
<i>U.S.</i>	I (Aero)	25	0	25
	II (Other)	2	10	12
Total		130	20	150

Gender

Overall, 34 female (22.7%) and 116 male (77.3%) subjects from the four main groups participated in the study. The gender ratio varied considerably according to the field of study and the native language.

The highest disproportion by gender was noted in the French group, where 36 of the 37 subjects were male. The genders were most evenly distributed in the British group. Sixteen (or 59.3%) of the subjects in the

British group were male, while 11 subjects were female. Table 4 shows the distribution of genders by group.

Table 4

Gender Distribution by Group

Group	Subgroup	Male	Number Female	Total
<i>British</i>	I (Aero)	8	1	9
	II (Other)	8	10	18
<i>French</i>	I (Aero)	18	1	19
	II (Other)	18	0	18
<i>German</i>	I (Aero)	25	2	27
	II (Other)	15	7	22
<i>U.S.</i>	I (Aero)	23	2	25
	II (Other)	1	11	12
Total		116	34	150

As Table 4 shows, strong variations in the gender distribution could be observed within all groups according to the field of study. This is a reflection of the different preferences in field of study among male and female students. The gender ratio among the subjects who studied aeronautics was highly skewed towards the male side. Of the 80 subjects in all subgroups I (Aero), 74 (or 92.5%) were male. Six (or 7.5%) female subjects studied Aeronautics. For the 70 subjects studying in a non-aviation related field (subgroups II), the genders were more evenly distributed. Forty-two (60%) of the students in these groups were male, while 28 (or 40%) were female.

Previous Flight Experience

Subjects were asked about their previous experience as passenger on a commercial aircraft/airliner. Overall, 135 subjects, or 90%, had flown before, while 15 subjects, or 10% had not done so.

Of the 15 students that had not flown before, ten (66.7%) did come from the *French* group (from subgroup II). One subject from the *German* group (subgroup I) and three subjects from the *British* group (subgroup II) had not flown before. In the *U.S.* group, one student from subgroup I had not flown on a commercial aircraft before.

Table 5

Flight Experience by Group

Group	Subgroup	Number		Total
		Experience	No Experience	
<i>British</i>	I (Aero)	9	0	9
	II (Other)	15	3	18
<i>French</i>	I (Aero)	19	0	19
	II (Other)	8	10	18
<i>German</i>	I (Aero)	26	1	27
	II (Other)	22	0	22
<i>U.S.</i>	I (Aero)	24	1	25
	II (Other)	12	0	12
Total		135	15	150

All 15 subjects without flight experience were male. The 34 female students in the four groups all had previously been as a passenger aboard a commercial aircraft.

Instrument

The reviewed literature did not suggest the existence of standardized tests to measure the interpretation and understanding of passenger safety briefing cards among subjects with different cultural backgrounds. Therefore, the researcher developed and pretested a five-part test/questionnaire for this study. Native speakers (graduate students at Embry-Riddle Aeronautical University including the researcher) reviewed and translated the tests from English into French and German. The tests/questionnaires were sent by mail to the participating universities and administered there by local contacts. Copies of the tests can be found in Appendices D, E, and F.

Description

The tests consisted of five parts on seven 8.5in x 11in U.S. standard letter pages:

1. In the first part, five questions solicited information about the subjects' *previous air travel experience* and their *exposure to safety cards*. Subjects had to indicate whether they had previously flown on a commercial aircraft (*yes/no*). If they had flown before, they were asked to state how often they usually flew per year (*about once or twice/several times/about each month*), when they did fly last (*less than a month ago/less than a year ago/more than a year ago*), whether they read the safety card on their last flight (*yes/no*), and – if they did not read the card – why (*knew its contents/did not want to/could not find it*).

2. An opinionnaire solicited the subjects' opinions regarding their *preferred safety card design* to test Hypotheses I and II. Subjects were asked to indicate (using the numbers 1, 2, and 3) the three design features which were most important to them if they had to design a safety card. The seven items

they could choose from were: (a) *drawings*, (b) *photographs*, (c) *durability of the card*, (d) *use of different languages*, (e) *multi-colored*, (f) *size of the card*, and (g) *words/writing*.

3. In an additional questionnaire-part, 13 *black-and-white pictograms* of a fixed size (50 mm x 50 mm and 50 mm x 75 mm, respectively) similar to those on current safety cards were presented to the test participants. The subjects were asked: "*For each of the symbols presented, please describe in a few words what you think they represent most likely.*" An example was included to show the intention of the question.

Three of the 13 pictograms focused on floor-level emergency exit lighting and color-coding of exits. Three pictograms depicted the requirement to take off (high-heel) shoes before using emergency exit slides. Two pictograms showed the correct method of using the exit slides, and two symbols represented the prohibition of the using electronic equipment aboard an aircraft. The other three pictograms pertained each to a special area: (a) supplemental oxygen, (b) in case of ditching, and (c) prohibition of butane lighters. The intention of this part was to investigate the actual understanding and interpretation of current safety card pictograms (Hypothesis IV).

4. The fourth part of the questionnaire/test contained three questions. In the first question, the subjects were presented with the situation that they had to open an *over-wing emergency exit door*. The scenario was presented in writing and in five line-drawings of the size 63 mm x 63 mm. The subjects had to select from four illustrated choices where they would *leave the door once removed from the frame*: (a) *on the seats in front of you*, (b) *throw it outside the plane*, (c) *on the seats in your row*, or (d) *on the seats in the row behind you*. This question was included in the test as an additional

indication of the general hypothesis that cross-cultural differences existed among the subjects from the four cultures.

To test the research hypothesis regarding the *color of lights to denote emergency exits* (Hypothesis III), a two-part question was introduced in the test. Since subjects with previous exposure to air travel were thought to answer the question depending upon their experiences, the question was posed in two ways:

In the first part (question 5a), the subjects were asked: "*Which color most likely indicates an exit?*" The subjects could choose from five options: (a) *white*, (b) *yellow*, (c) *red*, (d) *green*, and (e) *blue*.

In the second part of the question (5b), the subjects were asked: "*In your opinion, which color should be used to mark an exit?*" The subjects again could choose from the same five colors: (a) *white*, (b) *yellow*, (c) *red*, (d) *green*, and (e) *blue*.

5. *Biographical data* from the subjects were collected using the questionnaire-form in the last part of the test. These data included the subjects' gender (*female/male*), age in broad thirty-year intervals (*under 30, 30 to 60, over 60*), native language, home country, country where studying, and field of study (*major*).

Development and Features

The safety test/questionnaire was developed by the researcher at Embry-Riddle Aeronautical University. During all phases of the development, the researcher solicited input and opinions from various faculty, staff, and students at E-RAU.

In order to develop a data gathering instrument which was valid and reliable with respect to the understanding of safety cards, a sample of current

passenger safety briefing cards for jet aircraft was collected. Several U.S. and international airlines were solicited for safety cards from their fleets. A total of 82 cards were collected. Seventy-two cards from 24 operators in 12 countries pertained to jet aircraft. The safety cards in the sample were pre-sorted according to their main technique of presenting safety information, following the categories proposed by Schmidt and Kysor (1987). The researcher evaluated the cards with respect to special safety areas and possible ambiguities in their design (see *Review of the Related Literature*). Selected features of the cards were the basis for the development of a special safety test/questionnaire.

Since the reviewed literature suggested a significant influence of *previous flight experience* on safety card understanding, the first section of the test centered on this topic. Broad categories were chosen to minimize possible confusion and thus unreliable data from the subjects. The goal was to differentiate between subjects with casual and those with frequent experience, as well as between subjects with recent and those with past experience as aircraft passenger. Additionally, data regarding the usage of safety cards were collected.

The subjects did indicate their three *preferences of safety card design features* in an opinionnaire-form question. Seven common design features were identified from the sample of safety cards. To allow the subjects to "create" their favorite design, the three most important items were solicited.

In the main part of the test, 13 *pictograms* similar to those found on actual safety cards were presented. In open-ended questions, the subjects described in a few words what they thought the respective pictograms indicated. For the selection of the 13 pictograms that had to be interpreted, four main safety areas were identified: (a) *Floor-level emergency exit lighting*

and color-coding of exits (three pictograms); (b) *the requirement to take off (high-heel) shoes before using emergency exit slides* (three drawings); (c) *the correct method ("jump - don't sit") of using exit slides* (two pictograms); and (d) *the operation of electronic equipment on board* (two symbols). These four areas were found to be of special interest, since they either were critical to survival after an aircraft accident (e.g., the location and operation of safety exits and slides), or – as in the case of the operation of electronic equipment – were not intuitively obvious without special knowledge. As stipulated in U.S. FAR 91.21(a) (see Appendix G), the *operation* of any portable electronic device aboard an air carrier aircraft is prohibited, unless it is allowed through the special exceptions in FAR 91.21(b). Thus, the pictures were specifically included to test Hypothesis IV, using a regulation the subjects were most likely not completely familiar with.

Within the four main areas, the researcher identified two to three pictograms each from the safety card sample. To add some further indication about the influence of realism on the general understanding of pictures, the pictograms were chosen from the safety card sample by their degree of abstraction: For the removal of (high-heel) shoes, for example, the selected symbols varied from very naturalistic over somewhat naturalistic to very abstract (Figure 1). The same general principle was used to select the pictograms for the emergency exit floor lighting system (Figure 2), the exit slide usage (Figure 3), and the operation of electronic equipment (Figure 4)

Three pictograms from other areas were considered by the researcher to be probably ambiguous and thus included in the test. Additionally, these symbols served the purpose of "hiding" the pictures from the four main areas within a larger number of symbols.

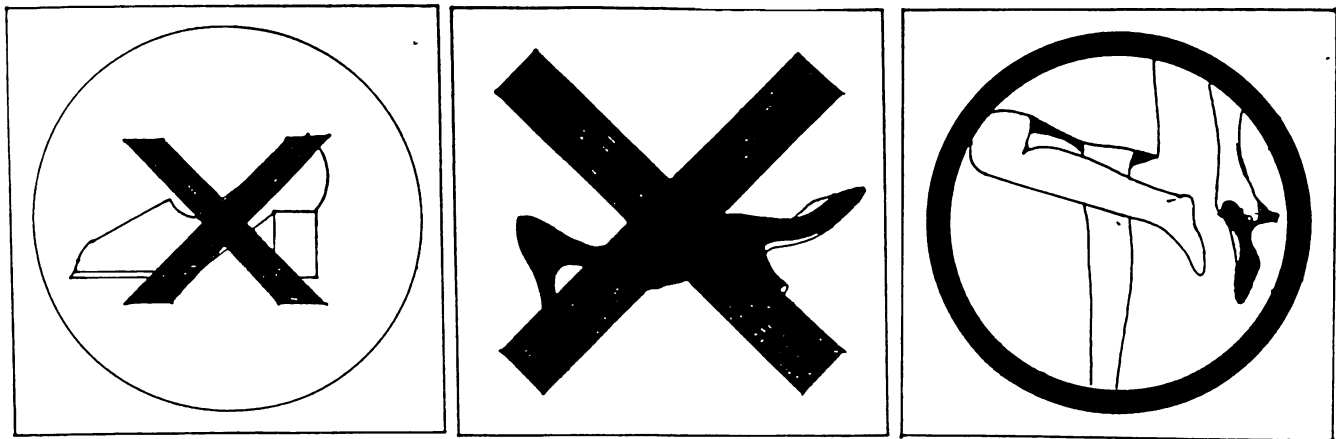

HEELS2

Very Abstract

HEELS1

Naturalistic

HEELS3

Very Naturalistic

Figure 1. The Three Pictograms Representing Instructions to Remove High-Heel Shoes (HEELS1, HEELS2, HEELS3).

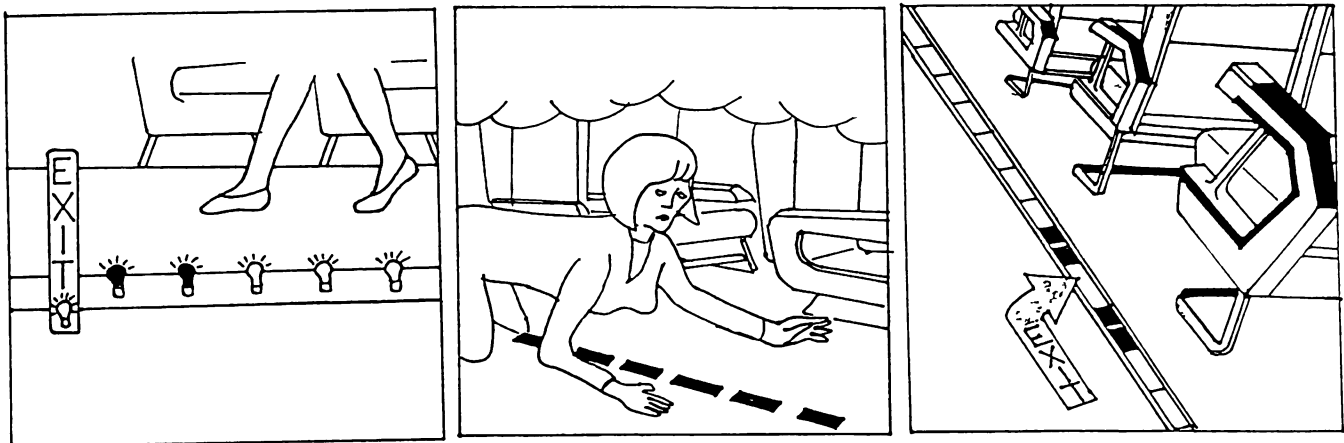

FLOORLIG

Abstract

SMOKELIG

Naturalistic

EXIT1

Very Naturalistic

Figure 2. The Three Pictograms Representing Information about Floor Exit Path Lighting (EXIT1, SMOKELIG, FLOORLIG).

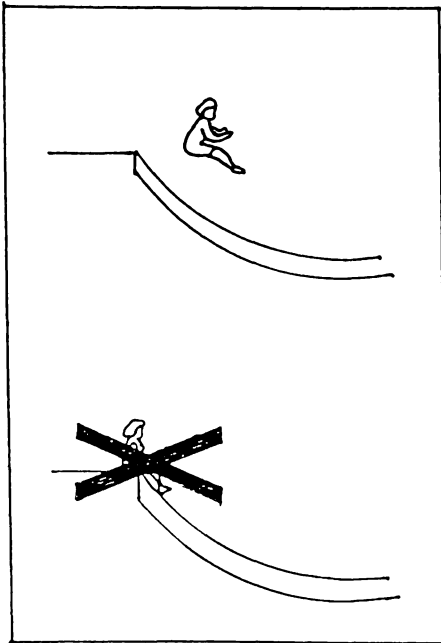

SLIDE1

Abstract

SLIDE2

Very Abstract

Figure 3. The Two Pictograms Representing Instructions for the Usage of Emergency Exit Slides (SLIDE1, SLIDE2).

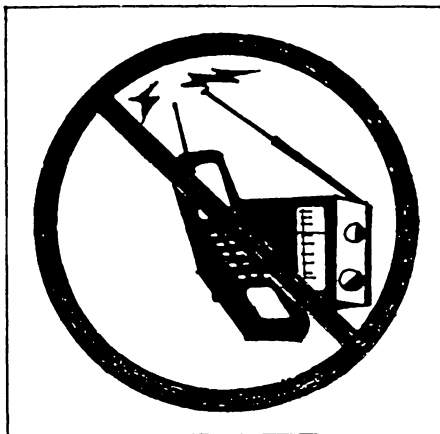

ELECTRO1

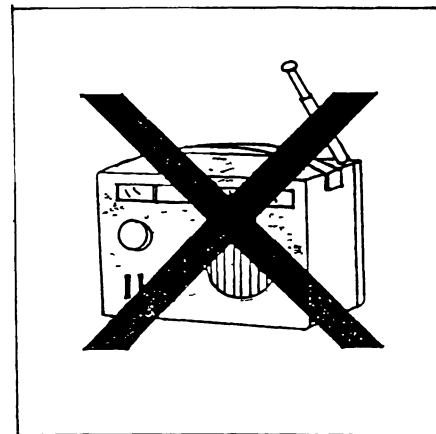
Abstract

ELECTRO2

Naturalistic

Figure 4. The Two Pictograms Representing the Prohibition to Use Certain Kinds of Electronic Equipment (ELECTRO1, ELECTRO2).

The 13 selected pictograms were similar to those on a total of 31 cards in the safety card sample. Thirteen airlines were represented with symbols: five from the U.S. (Continental®, Eastern®, Pan American®, United®, and U.S. Air®), five from Europe (Euroberlin France®, Hapag-Lloyd®, Lufthansa®, LTU®, and Luxair®), and three from Asia (Cathay Pacific®, Garuda Indonesia®, and Singapore Airlines®). Appendix H contains the pictograms used in the test and information about those cards whose symbols they resembled.

All symbols were redrawn by the researcher in a fixed size. Those pictograms which were originally circular or square were drawn in the size 100 mm x 100 mm for master prints. On the tests, the pictograms were reduced to a size of 50 mm x 50 mm. The two originally rectangular pictograms were redrawn in a size of 100 mm x 150 mm for the master prints and then reduced to 50 mm x 75 mm on the test. While three colors (black, blue, red) were used on the larger master prints, only pictograms in monochrome black/grey/white appeared on the actual tests. The symbols were redrawn to enhance the print-quality of the pictograms on the test and to exclude any biases induced by colors or different sizes.

Since the *operation of over-wing exit doors* are depicted differently on safety cards, one question in the test focused on this topic. The researcher prepared a perspective line-drawing of an over-wing exit row as seen from the aisle. The master copy was of the size 150 mm x 150 mm, later to be reduced to 63 mm x 63 mm for the test. Five copies were produced, in which the position of the door was varied. The first drawing showed that the door was to be removed. Following the options offered on current safety cards (see *Review of the Related Literature*), the other four pictorial representations showed four answer choices of where to put the emergency exit door once

removed from the frame: (a) *on the seats in front of the exit row*, (b) *outside the plane*, (c) *on the seats in the exit row*, or (d) *on the seats behind the exit row*. The pictures were included to avoid misunderstandings among the subjects regarding the four options. Additionally, the drawings helped subjects without air travel experience to imagine the situation.

Because subjects with previous exposure to air travel were thought to answer a question regarding the *color-coding of exits* on aircraft depending upon their experience, the question was posed in two ways: The first part of the question (*What color most likely indicates an exit?*) was intended to get information about the subjects' knowledge and previous experience and to prevent misunderstandings due to possible differences in experience and favorization of a certain color. The second part (*What color should be used?*) allowed subjects who had previous exposure to a certain color coding to express their agreement or rejection of that particular color, while it also gave subjects without previous flight experience the opportunity to indicate their preferred color.

The last part of the instrument collected *biographical data* from the subjects, such as gender, age group, native language, country of origin, university, and field of study. These data were intended to allow analysis for extraneous variables (within-groups factors such as gender vs. the between-groups factor, culture).

Test Instructions

The tests were given at different universities in several countries. To exclude biases due to changes in administration of the tests, special standardized test instructions were developed. The instructions focused on

administration as well as timing of the test and return of the survey forms to the researcher. Detailed instructions were given.

The sentences to be read to the students were included in the test instructions, so all subjects would receive the same directions. The instructions also contained detailed information about the timing of the test and the return of the survey forms to the researcher. The aim was to provide the local test administrators with the simplest and least time-consuming procedures.

The instructions which were originally developed in English were translated by native speakers into German and French. Sample copies of the test instructions can be found in Appendix I.

Design

The design approach of this study was a combination of both descriptive techniques for data collection and causal-comparative methods for data analysis. The study investigated differences among current university students from different cultural backgrounds with regard to their understanding and interpretation of aircraft passenger safety briefing cards.

To obtain the data, a combined questionnaire/opinionnaire was administered at seven universities in five countries. The institutions were selected from those to whom the researcher or faculty and students at Embry-Riddle Aeronautical University had contacts. The group included not only technical universities but also universities without a concentration in engineering or aviation. The narrowing of schools to those described did ensure local support for the project, timely answers, a 100-percent response rate, and thus more reliable data.

To assure confidentiality of the tests, the survey was designed in a way which did not allow the identification of particular respondents from the answer sheets without an in-depth knowledge of the respective university group. The only demographic data collected were gender, age group in broad thirty-year intervals, country of origin, major field of study, and personal air travel experience in broad intervals.

The causal-comparative method for data analysis was appropriate since the study attempted to determine the cause for probable differences in the understanding and interpretation of aircraft passenger safety briefing cards. In a $4 \times (2 \times 2 \times 2 \times 2)$ factorial arrangement, the subjects varied post-facto between groups according to their culture (*British, French, German, U.S.*), as well as within groups according to their field of study (*Aero, Other*), previous flight experience (*Yes, No*), gender (*Male, Female*), and age (*under 30, 30 and above*). The study attempted to determine whether the between-groups factor had a significant influence on the subjects' answers when compared to the within-groups factors.

No variables among the subjects were manipulated by the researcher. The test design was kept constant among all tests. All groups were predetermined, according to the subjects' culture and field of study. Thus, the experimental method was not indicated (Gay, 1987).

Limitations

The design of the study attempted to control for as many extraneous variables as possible. Standardized test instructions were used to keep the procedure as constant as possible. The questions were in the same order in all tests to exclude differences due to a change in the order of questions. Native speakers translated and checked the tests and the test instructions to exclude

any limitations that the usage of one language would have implied. Where possible, pictorial representations complemented the test questions. The subjects were exclusively university students, to restrict biases induced by differences in educational level. Subgroups were formed to control for variances in aviation knowledge.

There were, however, variables which the design of the study could not control:

1. Although the local research assistants were provided with detailed test instructions, the physical layout of the test environment as well as the actual procedure used during the tests were beyond the control of the study.

2. The subjects were asked to give professional answers. Since no direct incentive was offered to the students for completion of the test, the motivation of the students towards the test was beyond the control of the study.

3. The test was conveying information in writing and in pictures. The pictures were of constant quality and location on all tests. Although native speakers were used to translate the tests, subtle differences introduced during the translations from English into French and German, however, might not have been detected during the design. As shown earlier, verbal cross-cultural communication is subject to possible misunderstandings. These subtle, but perhaps significant differences were beyond the control of the study.

4. The limitation of the study to university students from four relatively similar Western cultures might have introduced a bias towards less distinct cultural differences. If, however, culture is to be determined as a significant factor among the subjects from an otherwise somewhat homogeneous group such as university students from Western democracies,

it can be assumed that these findings can be generalized towards much more heterogeneous groups, such as nations in Europe and Africa or Asia.

5. Due to the selection of entire classes for the test, age, gender, and previous flight experience could not be controlled. These factors must be considered as extraneous variables during the data analysis.

Procedure

Pilot Tests

To determine validity and reliability of the instrument, the test/questionnaire and the instructions were pre-tested during all stages of their development. During the initial phases, a prototype test was administered and discussed in a graduate level class on "Research Methods and Statistics" (MAS 605) at Embry-Riddle Aeronautical University. Findings from this pilot-test were incorporated in the design of the instrument. The final draft of the test/questionnaire was then pilot-tested in two classes at Embry-Riddle Aeronautical University: a Master's level class on "Human Factors in Aviation" (MAS 604) and an undergraduate class "Introduction to Psychology" (SS 220). After the review of the pilot-study, one question of the test and one part of the instructions pertaining to the time necessary for completion were changed slightly to exclude ambiguities which became apparent during the pilot test.

In the initial design of the questionnaire/test, subjects displayed problems regarding the question asking them "*You are now studying in . . .*" Instead of answering with the country, as intended by the test design, the students did answer this question with the name of their university. The question was therefore amended with the printed statement "*(country)*" to better reflect the intention.

The time for completion of the questionnaire had been estimated to be 30 to 45 minutes before the pilot tests. It became apparent during the pilot study, however, that the tests could be completed by all subjects within 10 to 15 minutes. Therefore, the time stated in the instructions for completion of the test was changed to 15 minutes.

Administration of the Tests

The test was administered at seven universities in five countries. The questionnaires and test instructions in the respective language were sent to the universities together with a self-addressed envelope and a cover letter explaining the purpose of the study. Contacts at the universities were professors, teachers, and assistants to whom the researcher or faculty and students at Embry-Riddle Aeronautical University had previous associations. The local test administrators selected an entire class from the specified field of study (aerospace or non-aerospace). Following the test instructions, the local contacts administered the test to the students in the respective classes in one session of approximately 20 to 25 minutes duration, including distribution and collection of the forms.

During the test, the subjects were informed about the purpose of the study and asked for their participation. They were advised not to sign their name anywhere on the test to guarantee anonymity. The subjects were informed that they had 15 minutes to complete the test, and that they would be reminded after 10 minutes that 5 minutes were left for completion of the test. The subjects were asked to answer the questions in the language of the country they studied in (i.e., English in the U.K. and the U.S., French in Belgium and France, and German in Germany).

After ten minutes, the test administrators informed the subjects that five minutes were left to complete the test. The students were also asked to make sure that they completed the questions soliciting biographical information.

At the end of the 15 minutes, the test administrators asked the participants to stop answering and to make sure that the biographical questions were answered. If the subjects had not completed this part, they were asked to do so at that time.

The answer sheets were collected by the test administrators and sent by mail in the self-addressed envelopes back to the researcher at Embry-Riddle Aeronautical University. All tests were received completely and within the time specified in the test instructions, except those from one university. Since the number of responses from ENAC was not sufficient after the first test, the test was again administered to other students to reach the targeted total number of about 20 students. The answers from the additional test were received in a separate envelope.

After the completed questionnaires/tests had been received by the researcher at Embry-Riddle Aeronautical University, the results were translated by native speakers where needed, categorized, and compiled into a database that allowed statistical analyses. The collected data were used to reject or accept the four null hypotheses derived from the previously stated research hypotheses.

Analysis

General Approach

Two types of data were collected during the study. Most data were nonparametric (ordinal). Other data, such as the design-preferences for safety cards, were transformed into parametric weighted scores (interval data). Since the two types of data existed, both the statistical methods for nonparametric data (Chi-Square) as well as the Analysis-of-Variance method for parametric (interval) data were employed. Throughout the analysis, it was attempted to avoid introducing Type I errors into the study, i.e., declaring that a significant difference due to culture existed, when, in fact, there was no difference. It was felt by the researcher that this procedure would give more weight to those areas where differences could be observed. Therefore, a conservative approach was selected in determining whether significant differences existed between the cultures.

One of the areas of concern during the analysis was the composition of the tested groups. The subjects who participated in the test varied between the main groups (*British, French, German, U.S.*) by their culture, i.e., native language. Within the cultures, the subjects varied according to their field of study (*Aeronautics, Other*), previous flight experience as passenger (*yes, no*), gender (*female, male*), and age (*under 30, 30 or older*). This represented a $4 \times (2 \times 2 \times 2 \times 2)$ factorial arrangement.

The design of the study did not control for a balanced or representative factorial arrangement of subjects among the groups. With the relatively small number of subjects participating, some factorial groups were not represented at all, or only with few subjects. In the *French* group, for example, only one female subject was represented. This did not allow any statistical analysis by gender

paired with native language when the *French* group was included. Other groups were strongly biased with respect to age. Most (ten) of the 20 subjects who were 30 years of age or older came from the *U.S.* group, while only one subject from the *German* group was 30 or older. Therefore, a full multiple analysis of variance (ANOVA) combining the five factors language, field of study, previous flight experience, gender, and age was not indicated. Instead, a three-fold approach was selected to test for the variances according to culture.

All Subjects

In the first test, *all subjects* from the four main groups (*British, French, German, U.S.*) were included. When indicated by the type of data, a one-way analysis of variance (ANOVA) was conducted with the respective test answers as the variable and native language as the factor. When ordinal data were analyzed, a Chi-Square test was used. Since these tests included all subjects, they also incorporated all possible biases due to the skewness of the test groups. Therefore, if culture (i.e., native language) was found to have a significant (i.e., $p < 0.05$) effect, it had to be tested whether this influence was caused by the varying compositions of the groups with respect to age, gender, or field of study, rather than by culture.

Highly Stratified Subgroup

It was possible that the one-way ANOVA or Chi-Square test incorporating all subjects was inconclusive regarding a significant influence of culture. Therefore, second one-way ANOVAs or Chi-Square tests were performed for all hypotheses, using a *highly stratified* subgroup. A sufficient number of otherwise uniform subjects was found among three main groups (*French, German, U.S.*) which were to be analyzed for the research hypotheses. All students in this

highly stratified group studied *aeronautics*, had *previous flight experience* as passengers, were *male*, and under *30 years of age*. From the *French* group, 16 students fulfilled these parameters. Twenty-four *German* students and 22 *U.S.* students were represented in the *highly stratified group*. The five subjects from the *British* group who fell into the category were not considered, if necessary for analysis, due to the insufficient number of subjects from that subgroup.

A one-way analysis of variance (ANOVA) was conducted to test for the influence of culture (i.e., native language) among the subjects from the *highly stratified group* for parametric data. For ordinal data, a Chi-Square test was employed. If culture had a significant ($p < 0.05$) effect on the test answers among *all subjects* and among the *highly stratified group*, it was assumed that these results could be generalized towards the respective populations. Conversely, if no significant effect of culture was found for both groups (*all, highly stratified*), it was assumed that there was no significant difference between the subjects in the study due to their culture.

The *highly stratified group* included those subjects who studied *aeronautics* and thus had considerable knowledge regarding aviation-related topics. Therefore, it was not assumed that a lack of a significant difference by culture within the *highly stratified group* necessarily meant that there was absolutely no difference between subjects from different cultures. In contrast, the *highly stratified group* was only used to confirm observed differences among *all subjects*. In those cases where the *highly stratified group* would not confirm the influence of culture found for *all subjects*, further tests were conducted.

Control Tests

1. Where the ANOVAs/Chi-Square tests for *all subjects* and for the *highly stratified group* indicated a significant effect of culture, Tukey HSD pairwise

comparisons or additional two-way Chi-Square tests were used to determine which cultures differed significantly. Additionally, the direction of differences according to culture was investigated.

2. To reach conclusive results in those cases where the results varied considerably between *all subjects* and the *highly stratified group* (i.e., not significant for one, but significant for the other group), the test answers were analyzed for other variables, such as *age, gender, previous flight experience, and field of study*. For each of the parametric factors, a Chi-Square test was performed to determine whether the extraneous variables had a significant influence on the test results. If one factor could be determined as significant ($p < 0.05$), the subjects were reordered according to this factor. Within the new stratified subgroups, a one-way ANOVA or Chi-Square test by language was performed to determine whether culture had a significant influence on the test results besides the previously identified extraneous variable. If no other factor was determined as significant, pairwise t-tests/Chi-Square tests between the suspected groups were performed. If the t-test/Chi-Square test was significant, it was concluded that culture did have a significant influence on the subjects' answers.

3. No further tests were conducted if both the ANOVAs/Chi-Square tests for *all subjects* and for the *highly stratified group* did not indicate a significant influence of culture on the subjects' answers. It was concluded that in those cases, culture did not have a significant influence on the subjects' answers.

Safety Card Design Features

Description

In question 2 of the questionnaire/test, the subjects were asked to indicate the three features they would put the most emphasis on if they had to design a passenger safety card. The subjects indicated their design preferences with the

numbers 1, 2, and 3, where 1 indicated the most important item. Tables 6, 7, and 8 show the distribution of the design features by native language.

Table 6

First Design Choices in Percents by Country

	British	French	German	US	Total	N
Colors	0.00	0.00	2.04	0.00	0.67	1
Drawings	66.67	67.57	67.35	43.24	61.33	92
Durability	3.70	2.70	0.00	5.41	2.67	4
Language	11.11	27.03	20.41	5.41	16.67	25
Photos	14.81	0.00	4.08	32.43	12.00	18
Size	0.00	0.00	0.00	2.70	0.67	1
Words	3.70	2.70	4.08	10.81	5.33	8
Total	100.00	100.00	100.00	100.00	100.00	
N	27	37	49	37	150	

Table 6 indicates that 61.3% of the subjects selected drawings/pictograms as their first choice. It is notable that, although a relative majority of 43.2% of the U.S. subjects also selected drawings as their first choice, this proportion was considerably lower than for the British (66.7%), French (67.6%), or German (67.4%) groups. Photos, however, were selected by 32.4% of the U.S. subjects. And while photos were chosen by 14.8% of the British subjects, no French student and only 4% of the German students decided in favor of photos for their first design choice.

Any form of written instructions was chosen by 22% of all subjects as a first choice: 16.67% selected multiple languages, while 5.33% of all subjects favored words/writing. About 27% of the French, 20% of the German, 11% of the British subjects, and 5% of the U.S. subjects chose multiple languages. Words

were selected by 4% of the German students, 10.8% of the U.S. subjects, 2.7% of the French, and 3.7% of the British subjects.

Table 7

Second Design Choices in Percents by Country

	British	French	German	US	Total	N
Colors	11.11	21.62	14.29	13.51	15.33	23
Drawings	7.41	24.32	10.20	27.03	17.33	26
Durability	7.41	5.41	2.04	0.00	3.33	5
Language	25.93	24.32	55.10	16.22	32.67	49
Photos	11.11	16.22	4.08	8.11	9.33	14
Size	0.00	2.70	8.16	10.81	6.00	9
Words	37.04	5.41	6.12	24.32	16.00	24
Total	100.00	100.00	100.00	100.00	100.00	
N	27	37	49	37	150	

Table 8

Third Design Choices in Percents by Country

	British	French	German	US	Total	N
Colors	14.81	8.11	28.57	13.51	17.33	26
Drawings	0.00	5.41	14.29	2.70	6.67	10
Durability	14.81	18.92	6.12	2.70	10.00	15
Language	25.93	21.62	8.16	24.32	18.67	28
Photos	0.00	16.22	0.00	10.81	6.67	10
Size	14.81	5.41	20.41	16.22	14.67	22
Words	29.63	24.32	22.45	29.73	26.00	39
Total	100.00	100.00	100.00	100.00	100.00	
N	27	37	49	37	150	

As indicated in Tables 7 and 8, worded instructions (i.e., words or multiple languages) became more emphasized as second and third design choices, whereas pictorial representations such as drawings and photos were primarily selected as the first design choice. This indicates that graphics were widely accepted by the subjects in the test as a primary means of conveying safety-related information. Approximately one-third of the subjects indicated that they liked colored representations. Color, however, was mostly selected as a second or third choice.

Drawings as a Design Feature

The reviewed literature indicated an emphasis on non-verbal communication in the high-context French culture and a French preference for graphic stimuli. In the low-context German culture, however, a high demand for detailed, preferably printed information was suggested. Therefore, it was hypothesized that French subjects would choose graphic representations (i.e., drawings) more often than German subjects when being asked about their design preferences on aircraft passenger briefing cards (Hypothesis Ia).

In order to consider the fact that the subjects could indicate their three design preferences, two tests were conducted. In the first test (*non-weighted*), the mentioning of a design choice by a subject (regardless of whether as first, second, or third choice) awarded that design feature one point each. The scores were used as ordinal data. Figure 5 shows the percentages of subjects by culture who chose drawings as a design feature.

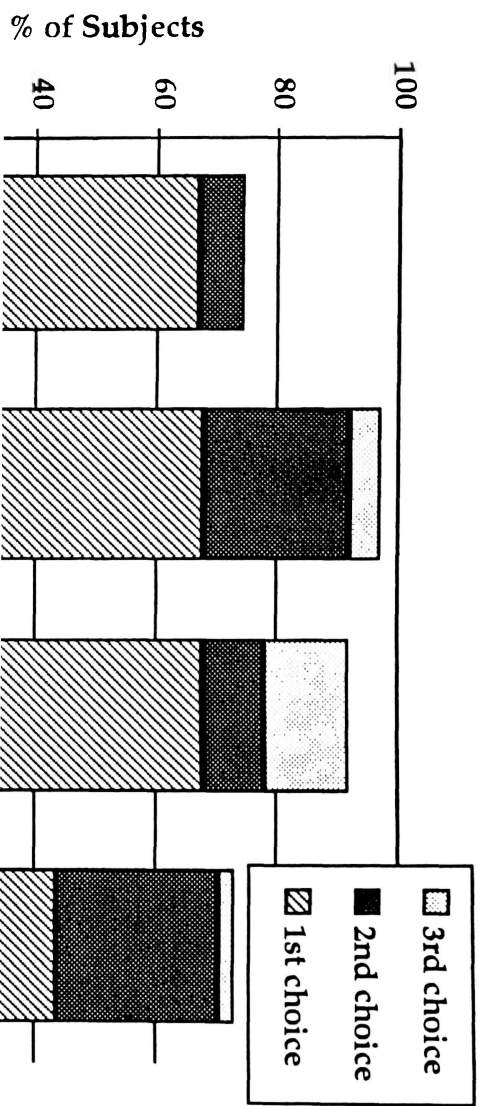

58

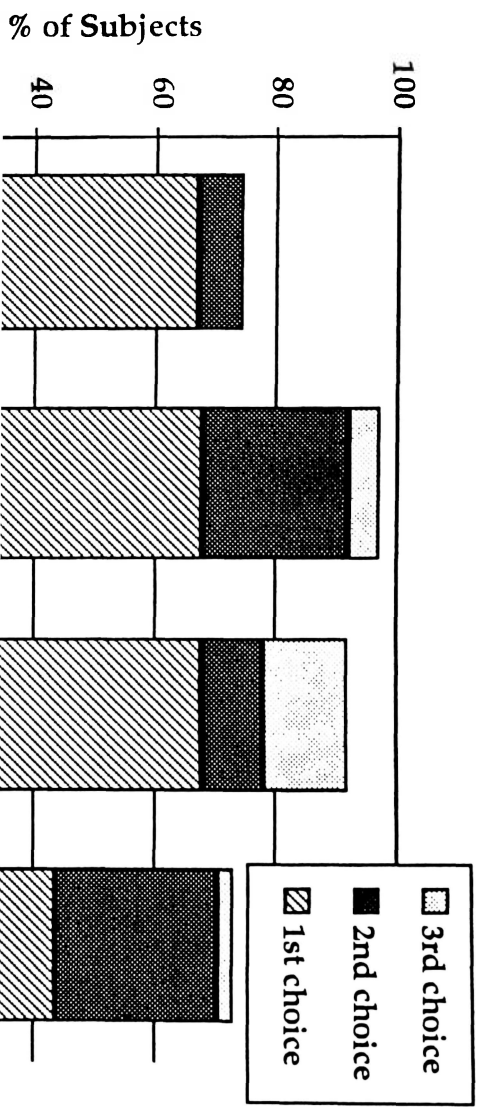

58

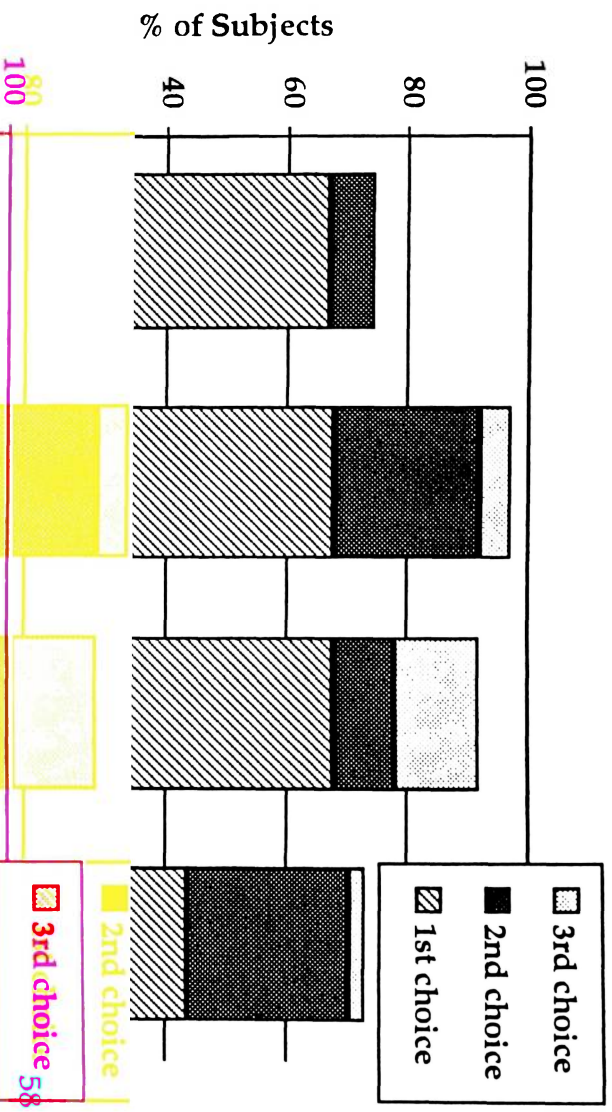

58

were awarded. For selection as a second choice, this feature received six points, and three points for being chosen as a third choice. No points were awarded if the feature was not mentioned at all by the subject. Using the weighted scores as interval data, the maximum mean score was 9.0, if all subjects in a group selected a feature as their first choice, while the minimum mean score was 0.0 if the feature was not mentioned at all.

Using the *weighted scores* as ordinal data, a Chi-Square test was conducted. Although significant differences due to culture among *all subjects* could be observed ($\chi^2=26.882$, $df=9$, $p=0.002$), no significant differences between the German and the French group were found: $\chi^2=5.252$, $df=3$, $p=0.154$.

Since the *weighted scores* were primarily intended as interval data, a one-way analysis of variance using the *weighted scores* was conducted. Culture was found to have a major effect at the $p=0.037$ level ($F=2.909$) for *all subjects*. Further analysis using a Tukey HSD comparison revealed a significant ($p=0.026$) difference between the U.S. ($M=5.595$, 3.752) and the French ($M=7.703$, $SD=2.184$) groups. However, no significant differences between the German group ($M=7.102$, 3.043) and the other groups were found. An ANOVA for the *highly stratified group* did confirm the absence of a significant difference between the German and French groups. For the *highly stratified group*, no significant differences between any cultures were found ($F(3, 63)=2.164$, $p=0.101$).

Significant differences in employing drawings as a design preference for aircraft passenger safety briefing cards were observed between the French and the U.S. groups for *all students*. Considering the *weighted* and *non-weighted* scores, no significant differences, however, were found between the German and the French group regarding the employment of drawings on passenger safety briefing cards. Hypothesis I stated an assumed significant difference between

the French and German groups and a specific direction of hypothesized difference which was not observed. Therefore, Hypothesis Ia was rejected.

Worded Instructions as a Design Preference

To test Hypothesis Ib, which stated that German subjects would select written instructions significantly more often than French subjects, the same principle of *weighted* and *non-weighted* scores as for drawings was used. Since the test question offered two features in the list which employed words (multiple languages and words/writing), a combined *weighted* and a combined *non-weighted* score for *worded instructions* was determined: For each of the two features, the normal *weighted* and *non-weighted* scores were calculated. The respective scores from the features were then added to a combined *weighted* or *non-weighted* score. Since each feature could only be mentioned once, the maximum possible mean score would have been $M=15 (=9+6)$ for the combined *weighted* score, if all subjects selected one feature as their first choice, and the other feature as their second choice, respectively. The minimum possible mean score would have been 0, if none of the subjects mentioned any of the two features. Figure 6 shows the percentages of subjects by culture who chose worded instructions as a design feature for aircraft passenger safety cards.

The Chi-Square test for the *non-weighted* scores found no significant differences due to culture for all subjects: $\chi^2=2.1258$, $df=2$, $p=0.3455$. In a control-test, no significant differences were observed between the German and the French groups: $\chi^2=2.037$, $df=2$, $p=0.3612$.

Conducting the respective ANOVAs for *all subjects* and the *highly stratified* group, no significant differences were observed between any of the groups. For the combined *weighted* score, the values were $F(3, 146)=1.131$, $p=0.339$ for *all subjects*, and $F(3, 63)=1.111$, $p=0.352$ for the *highly stratified* group.

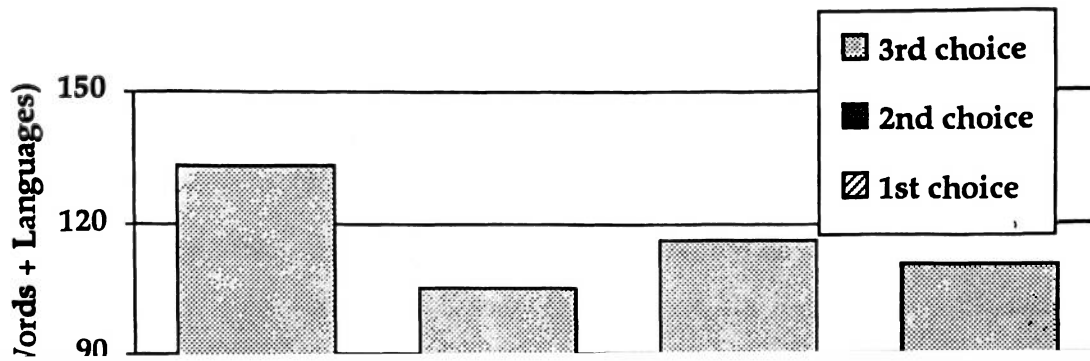
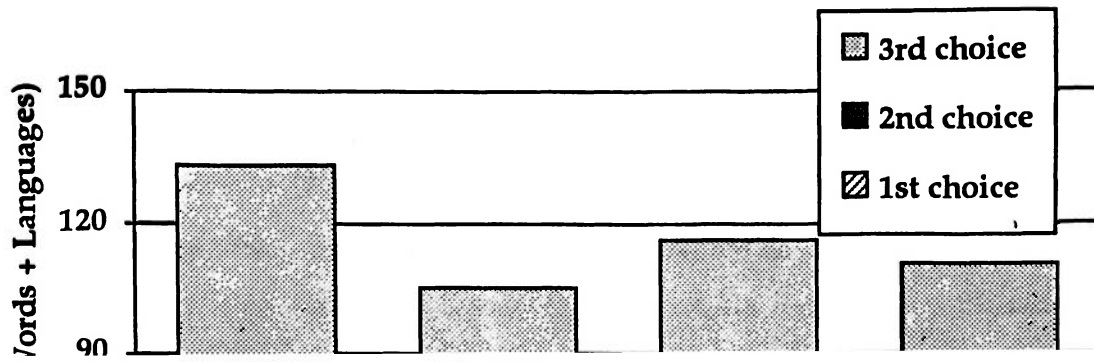
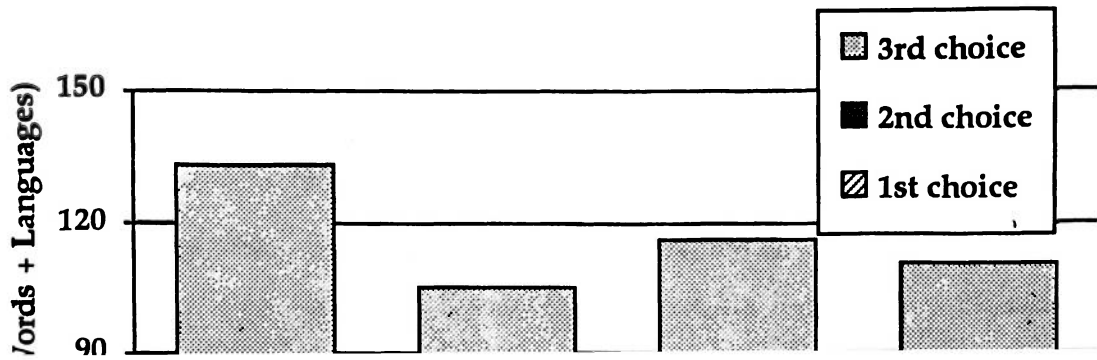

Photos as a Feature in the Design of Safety Cards

The data regarding the design preferences for aircraft passenger safety briefing cards were also analyzed regarding the preference for photos as a design feature. Photos were used relatively widely on U.S. safety cards but on only very few European cards. Additionally, it was hypothesized that photos would appeal to the realistic U.S. communication style suggested by the literature. Thus, Hypothesis II stated that U.S. subjects would indicate a higher preference for photos as a design feature on safety cards than European subjects.

Using the same design approach as for Hypothesis I, one-way ANOVAs were performed for *all subjects* and the *highly stratified group* with the *weighted* scores as the variables (interval data). The analyses revealed significant differences in the design preferences between the U.S. and the German groups and between the U.S. and the French groups for the *weighted* scores. U.S. subjects did choose photos significantly more often than German or French subjects. For the *weighted* scores and *all subjects*, the values were: $F(3, 146)=7.747, p<0.0005$, with Tukey HSD pairwise probabilities of $p=0.007$ between the French and U.S. groups and $p<0.0005$ between the German and the U.S. groups. No significant differences were found between the German and the French groups, the U.S. and the British, or the British and the French and German groups. These results were confirmed by the ANOVA for the *highly stratified group*: $F(3, 63)=4.530, p=0.006$. Figure 7 shows the percentages of subjects by culture who chose photos as a design feature for *all subjects*.

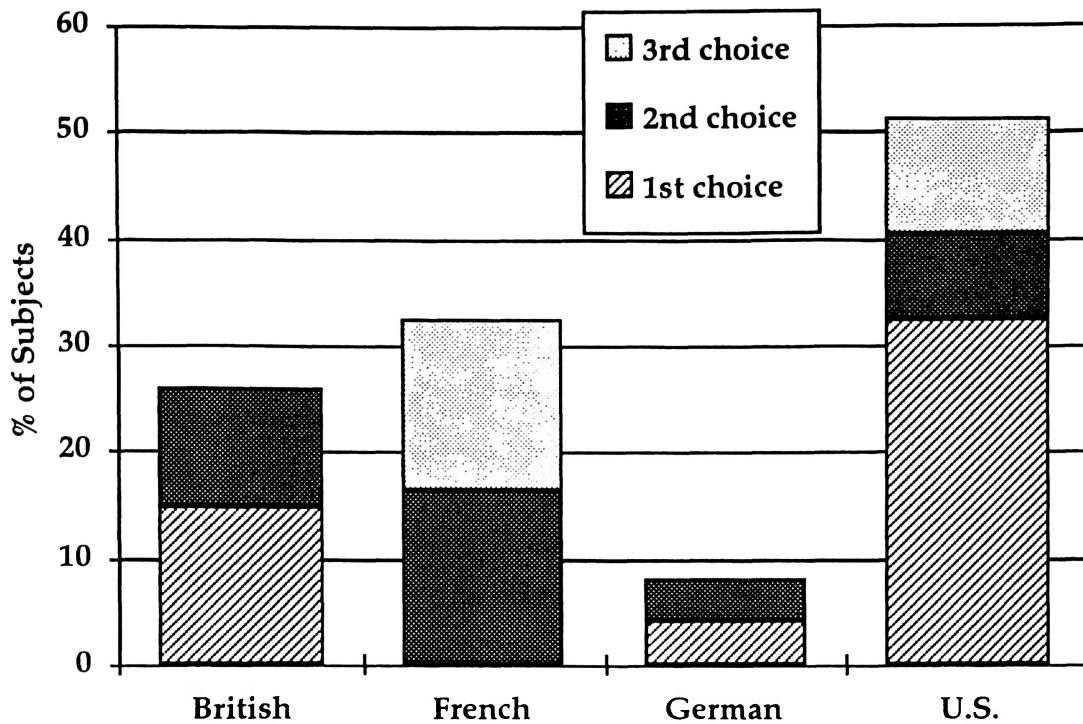

Figure 7. Photos as 1st, 2nd, and 3rd Design Choices for *all Subjects*. Percentage of Subjects by Culture.

For the *non-weighted* scores, significant differences could be observed between the U.S. and the German groups. With $\chi^2=19.990$, $df=3$, $p=0.0002$ for *all subjects*, and a pairwise $\chi^2=20.070$, $df=1$, $p<0.0005$, U.S. subjects chose photos more often than those from Germany. Since only four German subjects selected photos, one cell of the matrix was sparse. A Fisher exact test supported $p<0.0005$ between the German and the U.S. groups. The fact that the French group did not significantly differ from the U.S. group for the *non-weighted* scores ($\chi^2=2.720$, $df=1$, $p=0.0991$; Fisher exact test: $p=0.1570$) was attributed to the significant number of French subjects who mentioned photos as a second and third design choice.

There was no general significant difference between European and U.S. subjects regarding a preference for photos on safety cards. However, significant differences could be observed between the German and the U.S. groups and (when only considering the *weighted* scores) between the U.S. and the French groups. Therefore, the original Hypothesis II had to be rejected, since the differences were not uniform between the European and the U.S. groups.

Color-Coding of Exit Lights

Subjects were asked to indicate which color they thought indicated an exit in aircraft floor lighting (*current method*). The subjects also indicated which color – in their opinion – should be used for this purpose (*preferred option*). Since exit signs in buildings are red in the U.S., while they are green in wide parts of Europe, it was hypothesized that U.S. subjects would choose red over other colors, whereas Europeans would prefer green to other colors (Hypothesis III).

Highly significant differences regarding the observations and preferences for exit light color coding were found between the subjects from the U.S. and those from Europe. Chi-Square tests for both the *current method* and the *preferred option* showed significant differences when incorporating all color choices: For the *current method* and *all subjects*, culture had a significant influence at $p < 0.00005$ ($\chi^2 = 46.219$, $df = 12$). This finding was supported by the Chi-Square test for the *current method* and the *highly stratified group*: $\chi^2 = 40.3647$, $df = 12$, $p = 0.0001$. Highly significant differences were also found for the *preferred option* at $\chi^2 = 42.4203$, $df = 15$, $p = 0.0002$ for *all subjects*, and $\chi^2 = 38.4950$, $df = 15$, $p = 0.0008$ for the *highly stratified group*. The higher number of degrees of freedom for the preferred option resulted from two subjects who did not answer the question.

Further investigation of the test answered showed that subjects from the U.S. significantly more often chose red, while the European subjects preferred

green. Figures 8 shows the percentages of subjects by culture according to the color they selected as the *current method* for *all subjects*. The almost even distribution of the German subjects between red and green can possibly be explained by previous experiences, in which the subjects observed red as a color on aircraft from U.S. airlines. The subjects studied in Berlin. Until the end of the special air traffic rules in 1990, U.S. air carriers transported a high proportion of the passengers to and from Berlin.

green. Figures 8 shows the percentages of subjects by culture according to the color they selected as the *current method* for *all subjects*. The almost even distribution of the German subjects between red and green can possibly be explained by previous experiences, in which the subjects observed red as a color on aircraft from U.S. airlines. The subjects studied in Berlin. Until the end of the special air traffic rules in 1990, U.S. air carriers transported a high proportion of the passengers to and from Berlin.

green. Figures 8 shows the percentages of subjects by culture according to the color they selected as the *current method* for *all subjects*. The almost even distribution of the German subjects between red and green can possibly be explained by previous experiences, in which the subjects observed red as a color on aircraft from U.S. airlines. The subjects studied in Berlin. Until the end of the special air traffic rules in 1990, U.S. air carriers transported a high proportion of the passengers to and from Berlin.

color they selected as the *current method* for *all subjects*. The almost even distribution of the German subjects between red and green can possibly be explained by previous experiences, in which the subjects observed red as a color on aircraft from U.S. airlines. The subjects studied in Berlin. Until the end of the special air traffic rules in 1990, U.S. air carriers transported a high proportion of the passengers to and from Berlin.

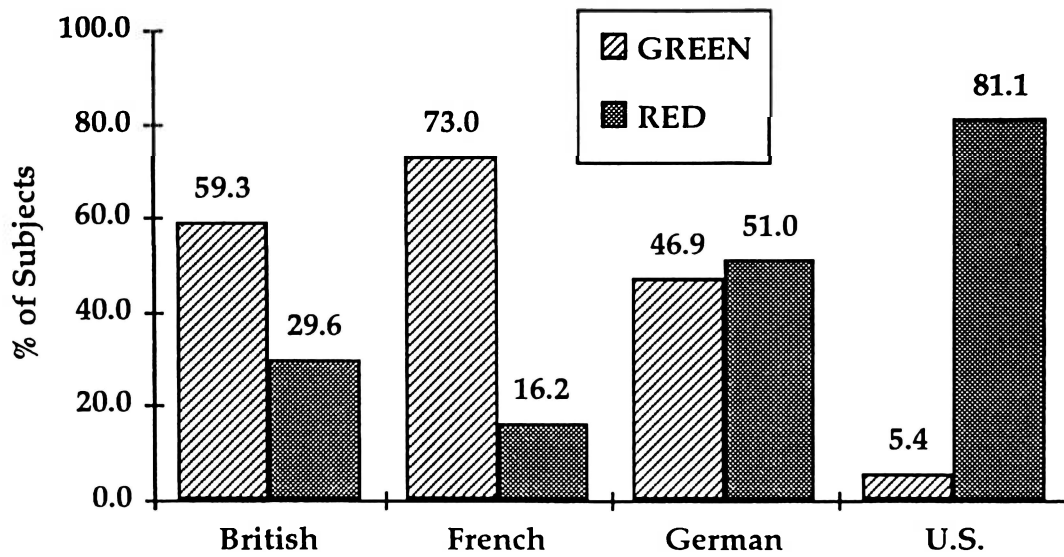

Figure 9. Color Coding of Exit in Floor Lighting. Comparison of Red and Green as the *Current Method* for all Subjects. Percentage of Subjects by Culture.

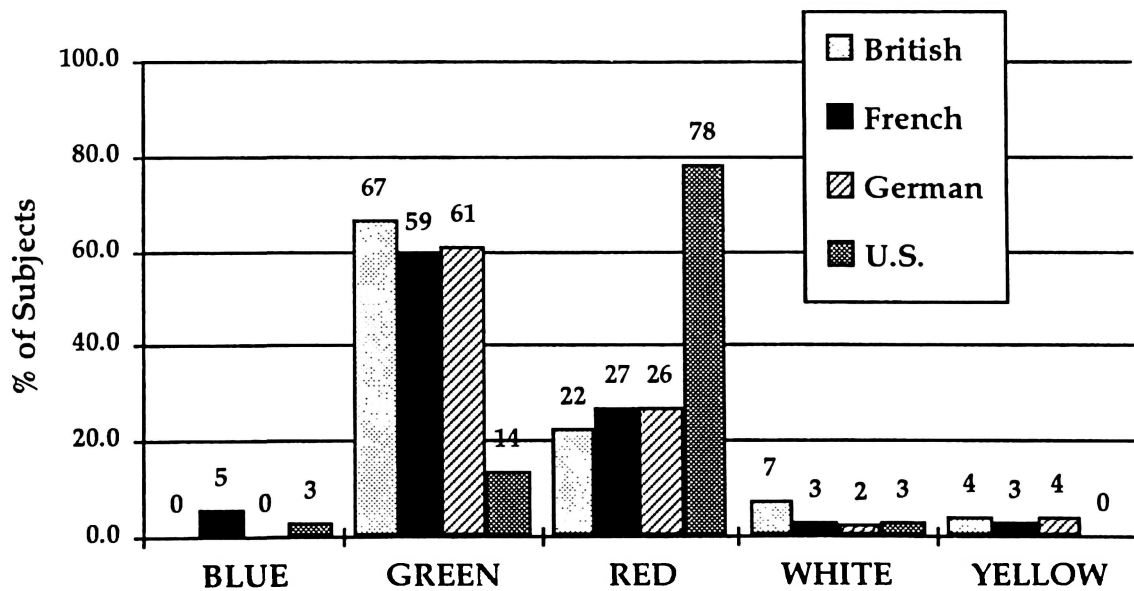

Figure 10. Color Coding of Exit in Floor Lighting. Indicated *Preferred Option* for all Subjects. Percentage of Subjects by Culture.

As shown in Figure 10, the variations between the European groups became smaller regarding the *preferred option*: 66.7% of the British, 59.5% of the French, and 61.2% of the German subjects chose green as their preference. Only 13.5% of the U.S. subjects selected green. For red, the ratios reversed: 78.4% of the U.S. subjects chose red, while 22.2% of the British, 27.0% of the French, and 26.5% of the Germans among *all subjects* selected red. The same general ratios could be observed among the *highly stratified group*. Figure 11 compares the selection of RED and GREEN for the *preferred option* for *all subjects*.

The Chi-Square tests indicated highly significant differences between the U.S. and the European subjects regarding the selection of colors for floor lighting to code emergency exits. These differences were in the expected direction. Therefore, Hypothesis III was accepted.

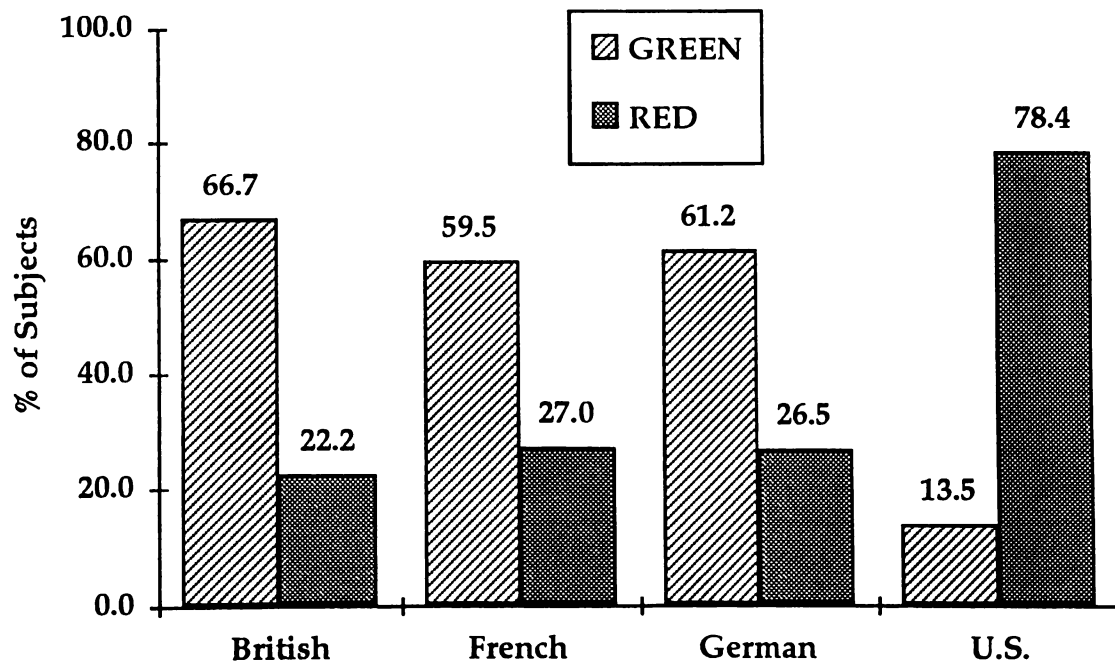

Figure 11. Color Coding of Exits in Floor Lighting. Comparison of Red and Green as the *Preferred Option* for *all Subjects*. Percentage of Subjects by Culture.

Interpretation of Pictograms

In the test, 13 pictograms similar to those on current aircraft passenger safety briefing cards were presented. The subjects were asked to describe in a few words what they thought the symbols represented most likely. An example was given to illustrate the type of requested answer. The pictogram given as an example showed a cigar and a pipe within a typical prohibition sign (Figure 12). The example of the type of requested answer was therefore: "*Do not smoke cigars or pipes.*" It was hypothesized that, due to the differing communication styles identified in the literature, the interpretation of pictograms would vary by culture (Hypothesis IV).



Do not smoke cigars or pipes

Figure 12. Example Given in the Test: "*Do Not Smoke Cigars or Pipes.*"

Approach

The subjects answered these open-ended questions with interpretations in their own words. No immediate values such as in multiple-choice tests could be assigned to their answers. To assess the understanding and interpretation of the symbols by the subjects and to allow statistical analyses, the students' answers were graded by the researcher. Three scoring levels were used:

1. An answer was considered to be *correct and complete* when all main safety information contained in the pictogram was stated by the subjects. The *complete and correct* answer for the given example contained three basic parts. The symbol showed (a) a cigar, (b) a pipe, and (c) the prohibition. Thus, any answer mentioning all three parts would have been graded as *correct and complete* and been awarded the value +1.0.

2. An *incomplete but safe* answer was one where the probable outcome of the subject's understanding and interpretation of the pictogram as indicated by the answer would most likely not have adversely affected the subject's safety or compliance with the underlying safety regulation. If, for example, a subject answered "*Do not smoke*" or "*Smoking prohibited*" when interpreting the symbol given as an example, this would not have adversely affected the subject's compliance with the stated rule "*Do not smoke cigars or pipes.*" The answer, however, would also not have been *correct and complete*, since smoking of cigarettes, for example, was not prohibited by the sign. An *incomplete but safe* answer was scored as neutral and awarded the value 0.0.

3. If an answer was *wrong or unsafe*, the incorrect interpretation of the symbol was either contrary to the intention of the pictogram, or it possibly endangered the safety of the subject in an applicable situation. An example of a *wrong or unsafe* answer for the pictogram "*Do not smoke cigars or pipes*" would, for example, have been: "*Smoking allowed*" or "*Cigars and pipes allowed.*" Since the reviewed literature (e.g., Johnson, 1984; Barthelmess, 1985) indicated that passenger inaction after aircraft accidents contributed significantly to the occurrence of fatalities and injuries, it was also considered to be *wrong or unsafe*, if no answer was given. Answers of this type were graded with a -1.0.

For each symbol, the different components of the pictogram were reviewed, and the respective answers were graded according to the standardized

requirements. The scores for each pictogram were analyzed using the aforementioned three-step process. The scores were used as ordinal data, since no degree of unsafety or safety could be determined.

Categorizations

All symbols were reviewed regarding contents and intention. For each pictogram, the components of a *complete and correct* answer were defined. Acceptable *incomplete but safe* answers were specified. The subjects' answers were then graded according to the categories.

Pictogram 1 (EXIT1). This symbol showed the location of an overwing emergency exit, as indicated by the different colored lights in the emergency lighted floor path (Figure 13). For their answer to be scored as *correct and complete*, the subjects had to mention both that an exit was located between the seat rows as well as the indication via the floor path. "*Follow floor lights to exit*" or "*Emergency exit lighting*" were examples of acceptable *complete and correct* answers.

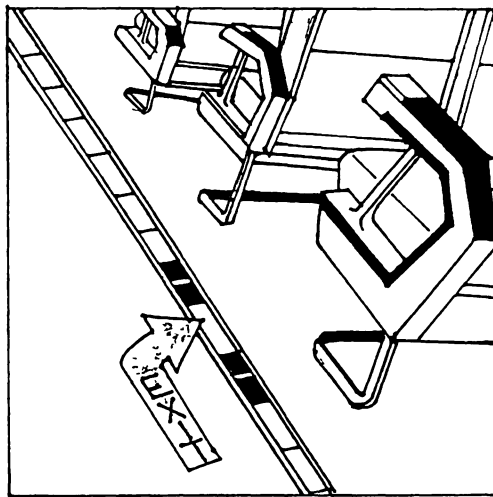

Figure 13. Pictogram 1 (EXIT1). *Follow Floor Lights To Exit.*

An answer which only mentioned the exit (e.g., "Exit located between seat rows" or "Exit this way") but not the floor path was considered to be *incomplete but safe*. The subjects would probably have found the exit in an emergency.

Examples of *wrong or unsafe* answers given by subjects for this pictogram were: "Follow arrow on floor to emergency exit" (there is no arrow on the floor in the airplane), or "In an emergency, the seat row must be pushed to the forward marker to use the emergency exit."

Pictogram 2 (SLIDE1). This pictogram indicated the correct and incorrect ways of using an emergency exit slide (Figure 14). "Jump – do not sit" was one of the most frequent *complete and correct* answers for this pictogram. Since the important feature was the correct method (jump), an answer such as "Jump when using exit slide" was also classified as *complete and correct*, although "do not sit" was not mentioned.

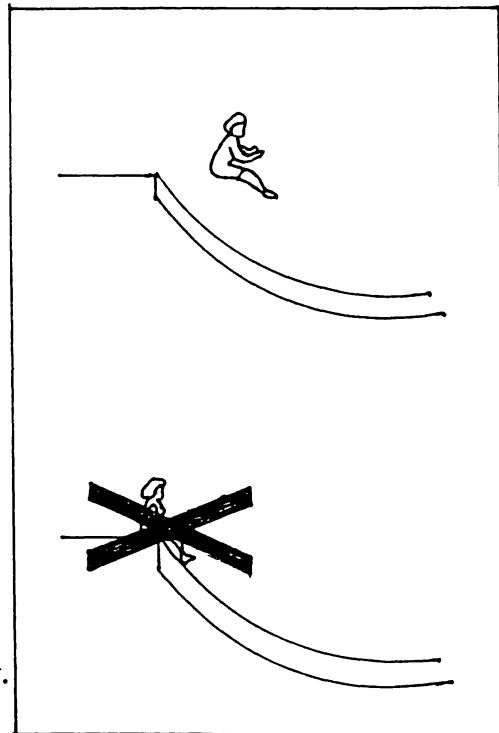

Figure 14. Pictogram 2 (SLIDE1). *Jump - do not sit.*

Incomplete but safe answers did not mention the correct method (jump), but noted the incorrect method (e.g., "Do not sit down", "Do not wait on top when using exit slide"). Other answers from this category were "Accelerate before using slide" or

"Use emergency slide quickly." Since it was not clear from the answers whether the subjects would actually jump, but perhaps sit down briefly before sliding down the chute, these answers could not be categorized as *complete and correct*.

Some subjects gave *wrong or unsafe* answers such as "Do not jump onto the emergency exit slide" or "Sit down before using exit slide." These answers contradicted the intention of the symbol.

Pictogram 3 (HEELS1). This symbol was one of three showing the instructions to remove high-heel shoes before using an emergency exit slide (Figure 15). A *complete and correct* answer mentioned the instruction to remove high-heel shoes, such as "Remove high-heel shoes," "Take off high heeled shoes," or "Take of stilettos" (a term most often used by subjects from *Hull*).

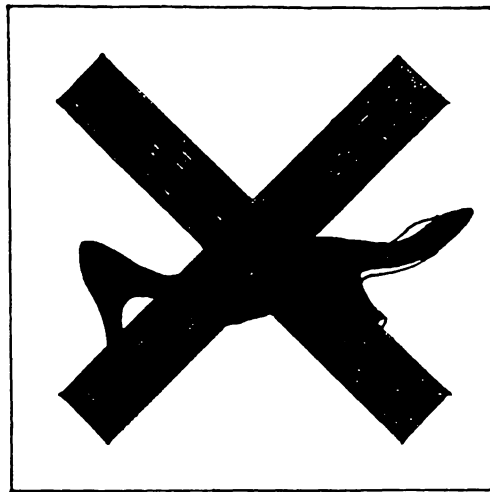

Figure 15. Pictogram 3 (HEELS1). *Remove High-Heel Shoes.*

An *incomplete but safe* answer was "Remove shoes." Although the instruction to remove all shoes is preferred by some airlines (e.g., Lufthansa, LTU, Hapag-Lloyd), problems can emanate when delays occur, or when survivors have to pass debris inside and outside the plane without shoes. Since the intent of the instruction to remove high-heel shoes for the use of the emergency slide would

have been fulfilled by removing all shoes, however, these answers were considered to be *incomplete but safe*.

Most *wrong or unsafe* answers reversed the intention of the pictogram and interpreted the symbol as a prohibition to take off shoes (e.g., "*Do not take off shoes*" or "*Prohibited to take off shoes*").

Pictogram 4 (OXYGEN). The depiction of a mask with the printed symbol O_2 as an indication of the location and operation of an oxygen mask was completely recognized by most subjects. Mentioning an oxygen mask was considered a *complete and correct* answer (Figure 16).

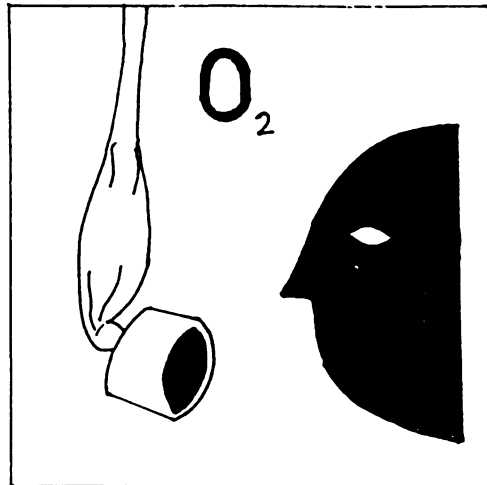

Figure 16. Pictogram 4 (OXYGEN). *Oxygen Mask.*

It was not completely clear whether the subjects who answered "*Poisonous fumes present*" or "*Gas mask*" realized the intention of the oxygen mask. Since they most likely would have used the mask, these answers were categorized as *incomplete but safe*.

The only two examples of *wrong or unsafe* answers for this pictogram were "*Danger of open fire*" and "*Tube supplies H_2O* ." In all other cases when the

categorization was *wrong or unsafe*, it was due to the fact that no answer was given.

Pictogram 5 (ELECTRO1). This symbol was one of two prohibiting the operation of certain electronic equipment aboard an aircraft. A cellular phone and a radio were depicted within the general symbol for prohibition (Figure 17). The correct and complete interpretation of the symbol in accordance with applicable regulations would have been "*Certain electronic equipment shall not be used aboard the aircraft.*" The criterion for the classification of an answer as *correct and complete* was, therefore, the mentioning of electronic items (such as radios or telephones) and of the fact that these items should not be *used*. Examples of *complete and correct* answers were "*Do not use transistors or portable phones*" or "*Do not use equipment that may interfere with frequency.*"



Figure 17. Pictogram 5 (ELECTRO1). *Do Not Use Certain Electronic Equipment.*

Since the regulations only prohibit the *operation* of electronic equipment, but do allow the *carriage* of these items aboard a plane, any answer that did not mention the usage was not considered *complete and correct*. Thus, answers such as "*No radios or telephones*" or "*Radio devices prohibited*" were considered to be *incomplete but safe*.

Wrong or unsafe answers did not assure that the equipment was not used (if not even carried). An example was "*Radio reception technically impossible*" which would probably have a reader try the operation of such equipment regardless of the statement.

Pictogram 6 (HEELS2). Although the picture was more abstract (Figure 18), the intention of this symbol was equal to that of Pictogram 3 (HEELS1). Thus, the same criteria were used.

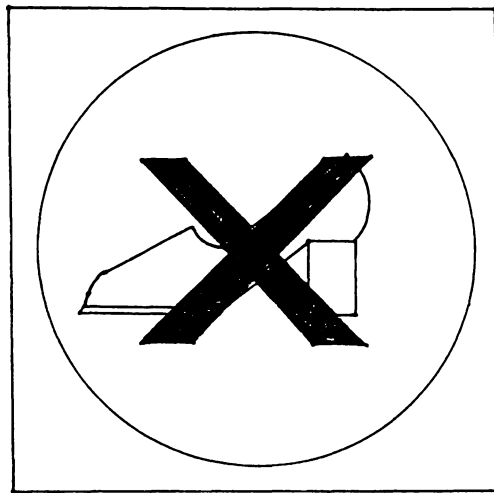

Figure 18. Pictogram 6 (HEELS2). *Remove High-Heel Shoes.*

Pictogram 7 (SMOKELIG). This symbol had two components: A floor guidance system (heavy dashed line) and the instruction to stay close to the ground / crawl under smoke in case of a fire (Figure 19). A *complete and correct* answer for this symbol mentioned both parts of the instructions (e.g., "*In case of smoke, follow the emergency exit markings on the floor*").

Incomplete but safe answers mostly did not mention the exit path marking on the floor but recognized the need to stay below the smoke in case of fire and to crawl towards an emergency exit. Since these answers indicated the correct interpretation of the immediate danger of smoke inhalation, which would result in more time to search for an exit, they were categorized as *incomplete but safe*.

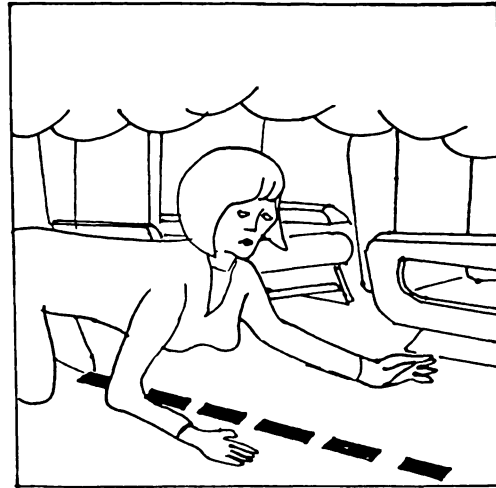

Figure 19. Pictogram 7 (SMOKELIG). *Crawl under Smoke and Follow Floor Markings.*

Examples of *wrong or unsafe* answers were "*Lie down on the floor*" (potentially dangerous) and "*Life vests are located under the seats.*" The latter interpretation was mentioned several times by subjects from different groups.

Pictogram 8 (SLIDE2). The intention of this symbol (Figure 20) was equal to that of Pictogram 2 (SLIDE1). Therefore, the same categorizations were used.

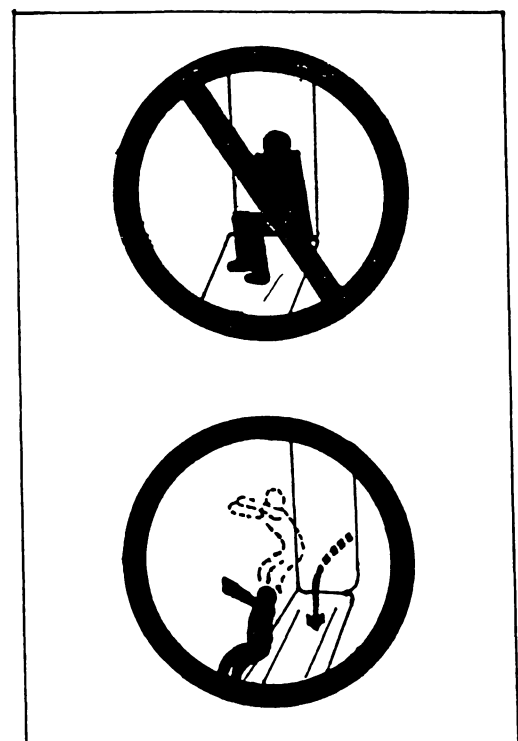

Figure 20. Pictogram 8 (SLIDE2). *Jump- do not sit.*

Pictogram 9 (DITCH). The depiction of a stylized airplane on water was used on several cards as an indication of "In case of an emergency landing on water, . . . [to be followed by instructions]" (Figure 21). The categorization used for this symbol was very strict: Only answers mentioning the intention of the pictogram as an introduction to other instructions were graded as *complete and correct*.

Thus, answers which merely mentioned "Airplane on water" or "Ditching" were only scored as *incomplete but safe*. Several *wrong or unsafe* interpretations were noted, such as "Plane will float" (possibly dangerous), "Seaplane" (a common answer), or "Seaplane landing area."

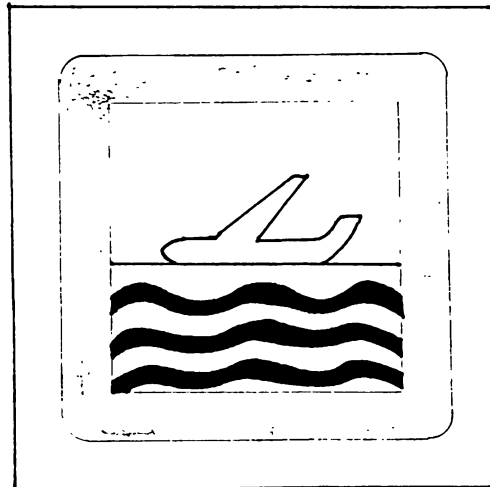

Figure 21. Pictogram 9 (DITCH). *In Case of an Emergency Landing on Water, . . . [to be followed by instructions].*

Pictogram 10 (HEELS3). This symbol (Figure 22) had the same intention as pictograms 3 and 6. Thus, the same classifications were used in the grading of the answers. During the categorizations, it was noted that many subjects whose answers were classified as *wrong or unsafe* indicated confusion as to whether the symbol meant to remove or wear shoes.

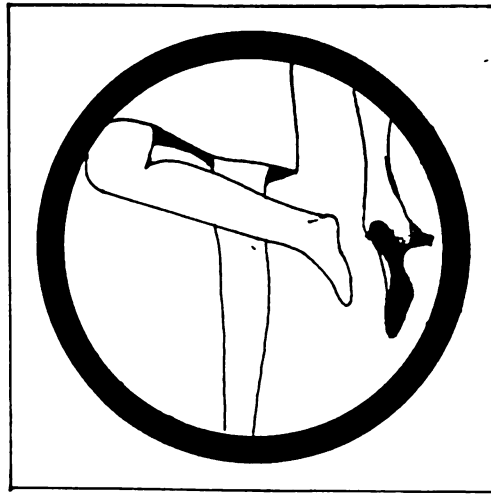

Figure 22. Pictogram 10 (HEELS3). *Remove High-Heel Shoes.*

Pictogram 11 (FLOORLIG). Similar to Pictogram 1 and 7, this symbol presented the emergency exit floor lighting (Figure 23). A *complete and correct* answer mentioned both the exit as well as the indication through the lighted path.

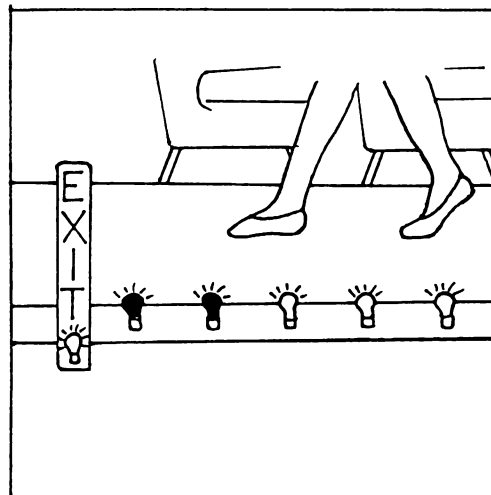

Figure 23. Pictogram 11 (FLOORLIG). *Colored Lights in the Floor Indicate an Emergency Exit.*

Incomplete but safe answers recognized that the picture pertained to an exit, but failed to mention that lights indicated the location. Although it is unclear whether the subjects realized that the exit was marked by lights, they probably would have remembered the very generic depiction of lamps in the picture when looking for the exit.

Many *wrong or unsafe* answers stated that the exit location was actually noted by a sign with the printed word "Exit." An example was "Exit is marked by sign."

Pictogram 12 (ELECTRO2). Having the same intention as pictogram 5, this symbol depicted a radio crossed out by two diagonal bars (Figure 24). Again, mentioning the fact that operation of such equipment (e.g., "Radios," "Transistors") was prohibited was necessary for the categorization as *complete and correct*. Since the applicable rule was assumed not to be known widely among the subjects, the mentioning of one type of equipment was sufficient, although the regulations state that the operation of all electronic equipment is prohibited unless specifically allowed.

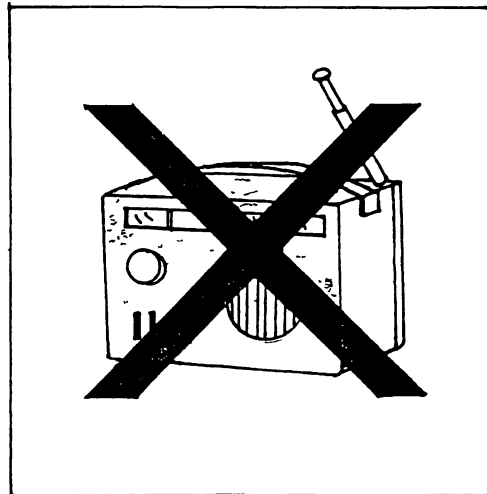

Figure 24. Pictogram 12 (ELECTRO2). *Do Not Use Certain Electronic Equipment.*

Incomplete but safe answers did not mention the operation, but the carriage of the specified equipment. Examples were "Do not carry radios," "Transistors prohibited," or "No radios."

Wrong or unsafe answers mistook the symbol for a prohibition of noise, but did not limit the operation of the equipment. An example was "No loud music."

Pictogram 13 (BUTANE). The depiction of a crossed-out gas lighter was found on the cards of one U.S. airline (U.S. Air[®]), together with the printed explanation "No butane lighters". Only answers that mentioned "No gas lighter" or "No butane lighter" were considered to be *complete and correct*, since the intention of the symbol was to ban the operation of pressurized lighters due to the possibility of high flames and explosions at reduced cabin air pressure during flight.

Matches, other lighters, or open flames were not prohibited by the sign. Since answers such as "No lighters," "No open/naked flames," or "No matches or lighters" assured that butane lighters also would not be used, these answers were categorized as *incomplete but safe*.

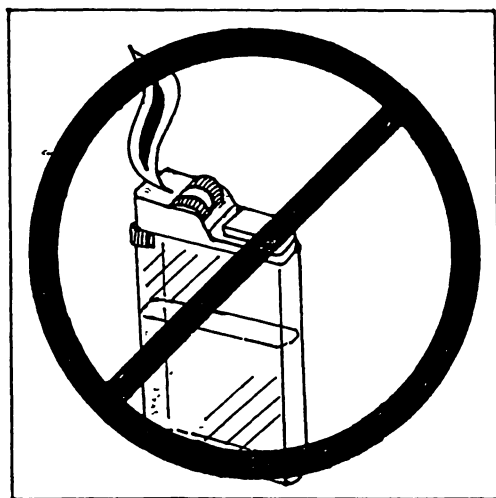

Figure 25. Pictogram 13 (BUTANE). *Do Not Use Butane/Gas Lighters.*

Most entries in the category *wrong or unsafe* were due to a lack of an answer. One answer, however, in this category was "Flammable." This answer did not assure that gas lighters would not been used, since the subject would perhaps make a mental connection between the pictogram and some part of equipment on the plane.

Results

Performing Chi-Square tests by language between *all subjects*, culture was determined to be of significant influence ($p < 0.05$) for five of the 13 pictograms: (a) Pictogram 1 (EXIT1), (b) pictogram 2 (SLIDE1), (c) pictogram 5 (ELECTRO1), (d) pictogram 7 (SMOKELIG), and (e) pictogram 11 (ELECTRO2). For the eight other pictograms, no significant influence of culture on the interpretation and understanding of the symbols was found among *all subjects*. Figure 26 shows the p-values for the influence of culture found during the analysis for all subjects.

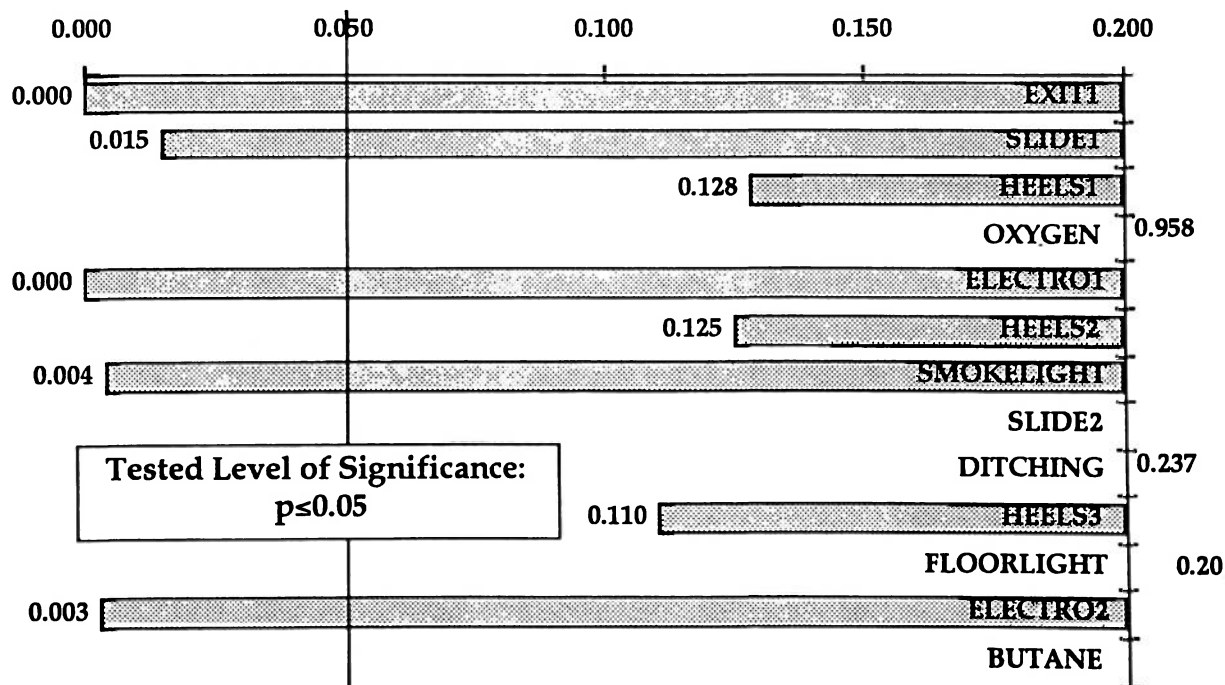

Figure 26. Cultural Differences in Interpreting Safety Card Pictograms. *p*-Values of Significance for *all Subjects* Using Chi-Square Tests.

The results of the Chi-Square tests by culture for the subjects in the *highly stratified group* (as defined earlier) confirmed a significant influence of culture on the interpretation of the symbols for four of the aforementioned five pictograms: Pictogram 1 (EXIT1), pictogram 2 (SLIDE1), pictogram 5 (ELECTRO1), and pictogram 12 (ELECTRO2).

For pictogram 7 (SMOKELIG), the Chi-Square test among the *highly stratified group* did indicate a significant influence of culture at $p=0.063$, slightly above the required level of $p<0.05$. Further analysis revealed that the significant influence was found for *all subjects* between the British and the German groups and between the British and the U.S. groups. The British group, however, was not represented in the highly stratified group. Thus, the results from this group could not show any differences between the respective groups. Appendix J contains the test results in interpreting pictograms by culture for *all subjects*.

Pictogram 1 (EXIT1). Significant differences due to culture were found among all subjects with $\chi^2=28.92$, $p<0.0005$, $df=6$ (Figure 27). The French subjects did give considerably more *wrong or unsafe* answers than all other subjects: 38% of the French answers were categorized as *wrong or unsafe*. However, only 2% of the German, 8% of the U.S., and 11% of the British answers were identified as *wrong or unsafe*. Most French *wrong or unsafe* answers indicated that the arrow (*flèche*) used in the symbol was actually installed in the aisle. Another wrong answer from the French group that was mentioned several times was "Ejection seat." Significant differences were found at $p=0.0221$ between the British and the French, at $p=0.0001$ between the French and the German, and at $p=0.0098$ between the French and the U.S. groups. Furthermore, significant differences were observed between the British and the German groups at $p=0.0394$.

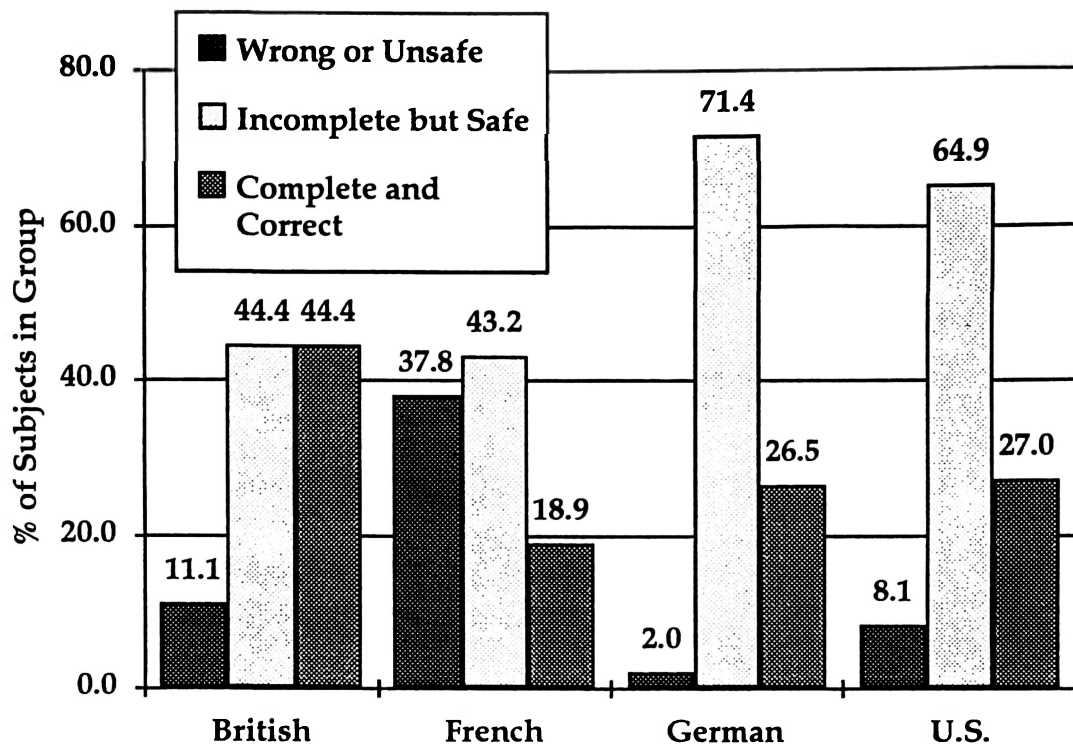

Figure 27. Interpretation of Pictogram 1 (EXIT1) for *all Subjects*. Percentage of Subjects by Culture.

The Chi-Square test for the highly stratified group confirmed the significant differences between the French and the other groups at $\chi^2=27.19$, $p<0.0005$, $df=6$. It was concluded that culture had a significant effect on the interpretation of pictogram 1.

Pictogram 2 (SLIDE1). Significant differences due to culture were found among *all subjects* in the interpretation of pictogram 2 (Figure 28). The Chi-Square test for *all subjects* showed a significant difference at $\chi^2=15.71$, $p=0.015$, $df=6$ between the German and the French groups (pairwise probability $p=0.0132$), as well as between the German and the British groups (pairwise probability $p=0.0219$). No significant differences were observed between the British and the French groups, or between the U.S. and any other groups.

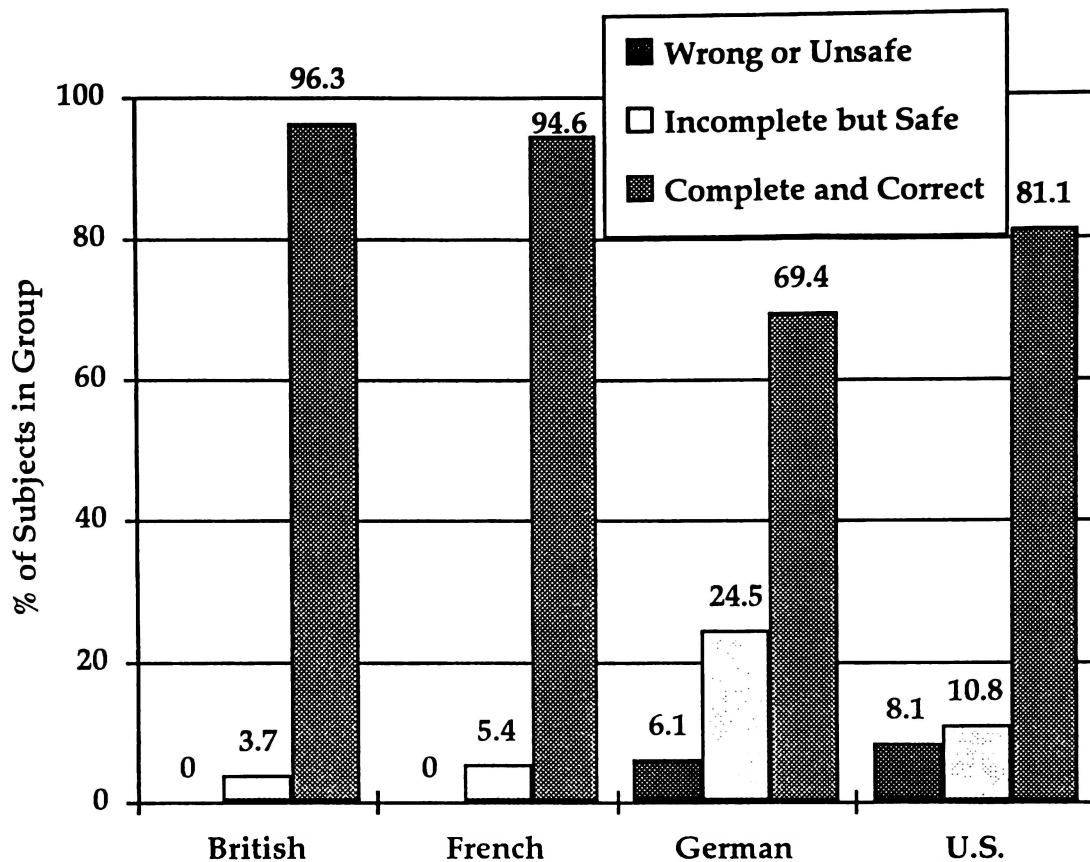

Figure 28. Interpretation of Pictogram 2 (SLIDE1) for *all Subjects*. Percentage of Subjects by Culture.

For the *highly stratified* group, the Chi-Square test confirmed significant differences at $p=0.0001$ ($\chi^2=13.204$, $df=6$). Further evaluation of the test scores revealed that the significant differences in the interpretation of pictogram 2 due to culture resulted from the comparatively high number of German answers that were classified as *incomplete but safe*. In this category, 24.49% of German answers were found, in contrast to only 3.7% of the French, 5.41% of the British, and 10.81% of the U.S. answers. Many German subjects did not include the correct method (*jump*) in their answers but used general statements which did not clarify whether they would jump down the emergency slide. Examples of such answers

were "Use slide as quickly as possible," "Do not hesitate on top of the slide," or "Don't stay seated on slide."

The analysis of the data suggested significant differences due to culture between the German and the British and French subjects. It was concluded that culture had a significant main effect on the interpretation of pictogram 2.

Pictogram 3 (HEELS1). The analysis of the answers for pictogram 3 did not suggest any significant influence of culture on the subjects' answers for any group ($\chi^2=9.928$, $df=6$, $p=0.128$). The percentages of subjects answering with a correct and complete answer did vary between 70% and 89%, however not significantly. Subjects from all cultures did recognize and describe the symbol at a high level of correctness. It was concluded that culture had no significant main effect on the interpretation of pictogram 3.

Pictogram 4 (OXYGEN). Many subjects in the pre-study pilot test had indicated that they considered the symbol for supplemental oxygen to be a particularly bad pictorial representation. However, this symbol received one of the highest overall rate of recognition of all pictograms in the test. More than 90% of subjects from all cultures described the symbol with a *complete and correct* answer, and only six of the 150 subjects did give a *wrong or unsafe* answer. No significant differences across cultures were observed in the analysis with ($\chi^2=0.544$, $df=6$, $p=0.997$) for *all subjects*. Thus, it was concluded that culture had no significant influence on the understanding and interpretation of pictogram 4.

Pictogram 5 (ELECTRO1). For the symbol prohibiting the use of electronic equipment aboard an aircraft, significant main effects of culture on the answers were found. The Chi-Square test and the subsequent pairwise comparisons for *all subjects* showed at $\chi^2=25.603$, $df=6$, $p<0.0005$ cultural differences between the U.S. and the French groups ($p=0.0003$), and between the U.S. and the German groups ($p<0.0001$). No significant differences were found

between the U.S. and the British groups ($p=0.3001$) or between the German and the French ($p=0.6779$) groups. Significant differences were again found when comparing the British and German ($p=0.0212$) groups, as well as the British and the French groups ($p=0.0154$). The observed differences were confirmed for the *highly stratified group* at $\chi^2=11.226$, $df=4$, $p=0.0241$, with significant differences between the German and the U.S., and the French and U.S. groups.

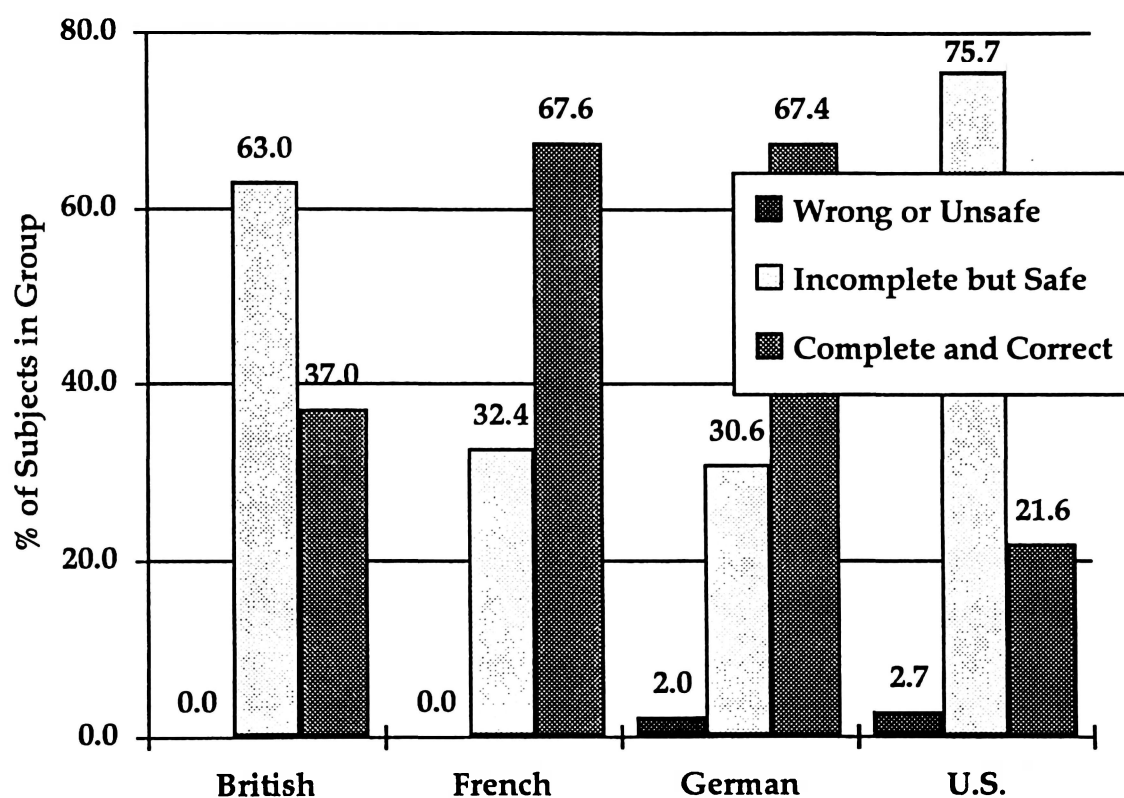

Figure 29. Interpretation of Pictogram 5 (ELECTRO1) for *all Subjects*. Percentage of Subjects by Culture.

The test results were reviewed more closely to determine the reason for the significant differences in the mean scores of the U.S. and French, and U.S. and German subjects (Figure 29). More than three-quarters of the U.S. answers

(75.68%) and almost two-thirds of the British answers were categorized as *incomplete but safe*. However, only 30.61% of the answers from the German and 32.43% from the French group were listed in this category. The reason for this difference was found to be the preference of U.S. (and British) subjects for the short answer "*No radios or telephones.*" While this answer was safe, it was ambiguous as to whether the subjects did correctly interpreted that only the *use* of electronic equipment was prohibited, whereas the *carriage* of such items was allowed. Fewer subjects from the U.S. (and British) groups than from the French and German groups used a version of the *complete and correct* answer "*Do not use radios or telephones.*" A possible explanation for this difference could be the brief and to-the-point communication style in the English language and the U.S. preference for short, headline-type statements. These characteristics were suggested by the reviewed literature. From the results, it was concluded that culture did significantly influence the interpretation of pictogram 5.

Pictogram 6 (HEELS2). This symbol was the second of three pictorial representations of instructions to remove high-heel shoes before using emergency exit slides. More than 70% of *all subjects* gave a *complete and correct* answer: 75.68% of the French, 75.51% of the German, and 75.68% of the U.S. answers were *complete and correct*. Only 59.26% of the British subjects gave answers in this category. The reversed situation was true for the *wrong or unsafe* answers: More British (18.52%) answers than French (2.70%), German (2.04%), or U.S. (5.41%) answers were found. However, the Chi-Square test for *all subjects* did not indicate a difference beyond the required level of significance of $p < 0.05$. The results were $\chi^2 = 9.980$, $df = 6$, $p = 0.125$.

Further study of the test answers of the British subjects indicated that the *wrong or unsafe* answers in that group resulted from several "*Don't know*" entries. One subject answered "*Do not obstruct aisle with loose shoes - not clear at all.*" Since

the statistical analysis did not reveal any significant differences, it was concluded that culture had no main effect on the interpretation of pictogram 6.

Pictogram 7 (SMOKELIG). The Chi-Square test for all subjects indicated significant differences due to culture at $\chi^2=18.978$, $df=6$, $p=0.004$. Pairwise Chi-Square tests revealed significant differences between the British and the German ($p=0.0303$) and between the British and the U.S. groups ($p=0.0225$). The reason was the variation of entries in the different categories: No British answer, but 16.22% of the French, 20.41% of the German, and 8.11% of the U.S. answers were categorized as *wrong or unclear*, mostly because no answer was given (Figure 30).

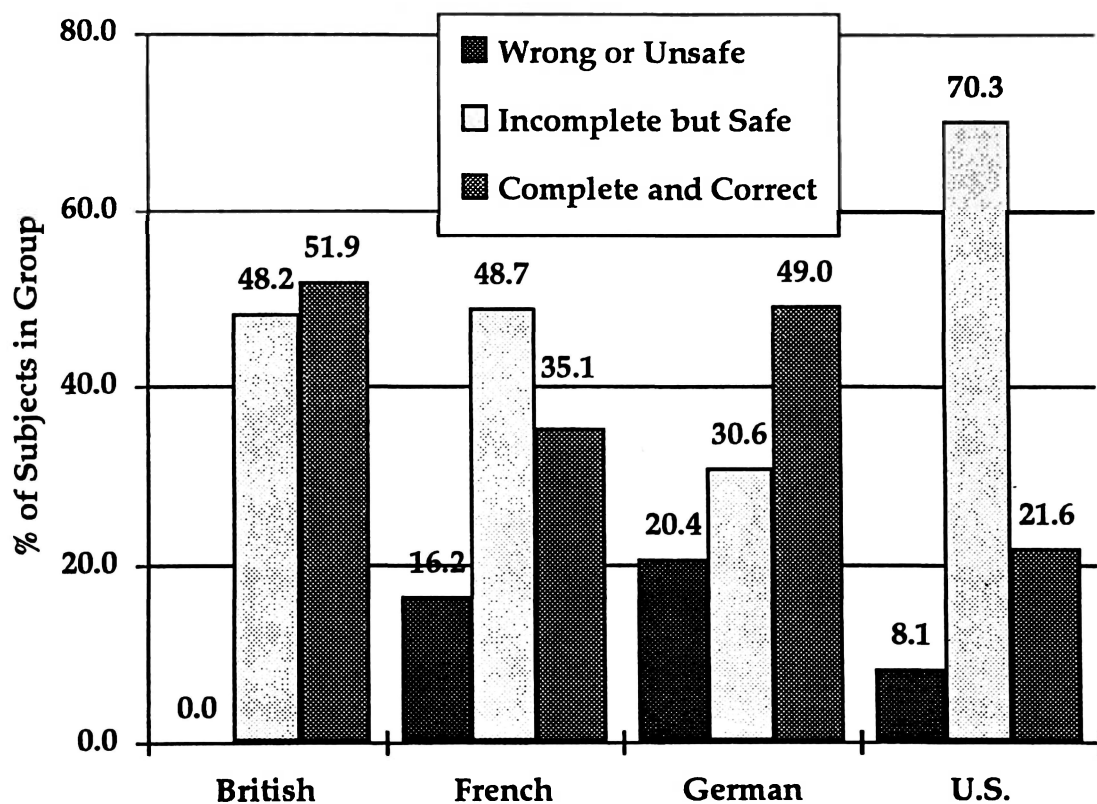

Figure 30. Interpretation of Pictogram 7 (SMOKELIG) for *all Subjects*. Percentage of Subjects by Culture.

The reverse ratios were found for the *correct and complete* answers: Here, 21.62% of the U.S., 35.14% of the French, 48.98% of the German, and 51.85% of the British subjects indicated both the danger from smoke and the emergency exit path lighting. Most answers from U.S. subjects (70.27%) lacked the information about the floor marking, and thus were categorized as *incomplete but safe*.

Review of the scores for the highly stratified group did not confirm the results for all subjects, since the British group was not represented. British subjects gave relatively more positive answers than subjects from other cultures, especially from the U.S. The statistical analysis found significant effects of culture on the interpretation of pictogram 7.

Pictogram 8 (SLIDE 2). The intention of this symbol was equal to that of pictogram 2 (SLIDE1). However, in contrast to the analysis for pictogram 2, no significant differences ($p=0.125$) due to culture were found for this symbol. For all subjects, the German answers did considerably more often (79.59% vs. 69.39%) mention the correct method of using an exit slide (jump). Furthermore, the percentages of *complete and correct* French (70.27% vs. 94.59%) and British (92.59% vs. 96.30%) answers reduced, alleviating the differences observed between the cultures for SLIDE1 to $p=0.125$ for SLIDE2. These results were confirmed by the Chi-Square test for the *highly stratified group* ($p=0.0627$). It was, therefore, concluded, that culture had no main effect on the interpretation of pictogram 8.

Pictogram 9 (DITCH). This symbol was similar to one found during the review of current safety cards on several German and one U.S. card. Its complete and correct meaning was "*In case of ditching . . . [to be followed by instructions].*" As indicated before, the subjects were graded very strictly. For *all subjects*, this symbol was incorrectly interpreted by almost half of the subjects (46%). Only 54% of *all subjects* gave an *incomplete but safe* (41.33%) or *complete and correct answer* (12.67%). Sixty-nine subjects, however, gave a *wrong or unsafe answer*.

Most *wrong or unsafe* answers interpreted the pictogram as a seaplane (*wrong*), or as an indication that the plane will float (*unsafe*).

No significant influence of culture could be observed for *all subjects*: $\chi^2=5.996$, $df=6$, $p=0.4236$. These results were confirmed with $\chi^2=0.9484$, $df=4$, $p=0.9175$ for the *highly stratified group*. It was concluded that culture had no significant main effect on the interpretation of pictogram 9.

Pictogram 10 (HEELS3). The third symbol depicting the instruction to remove high-heel shoes showed the lowest overall level of recognition of those three pictograms. The Chi-Square test for *all subjects* revealed no significant differences by culture at $\chi^2=10.3645$, $df=6$, $p=0.1101$. Pairwise comparisons, however, indicated a significant difference between the German and the U.S. groups at $p=0.0168$. Further analysis of the answers showed that almost 50% of the German subjects gave a *complete and correct* answer, whereas the percentage of *complete and correct* answers for the U.S. group was 21.62%. The reversal was found for *wrong or unsafe* answers: Only 10.20% of the German answers, but 27.03% of the U.S. answers were in this category. Most *wrong or unsafe* U.S. answers were due to the absence of any answer. Common, however, among the 28 subjects from all cultures who gave such answers was confusion as to whether the symbol meant to remove or wear shoes.

The Chi-Square test for the *highly stratified group*, however, showed significant differences at $\chi^2=12.7228$, $df=4$, $p=0.0127$ due to culture. The same difference between the U.S. and the German groups as for all subjects could be observed. While 36% of the U.S. subjects in the *highly stratified group* gave a *complete and correct* answer, 54% of the German subjects did so. In contrast, 32% of the U.S. subjects gave a *wrong or unsafe* answer, while only 8% of the German subjects gave such an answer. Although significant differences between the German and the U.S. groups could be observed, these differences were not large

enough to influence the Chi-Square test for all subjects. It was, therefore, concluded that culture had no significant main effect on the interpretation of pictogram 10.

Pictogram 11 (FLOORLIG). While two-thirds (66%) of *all subjects* gave a *complete and correct* answer, 22.67% responded with an *incomplete but safe* interpretation; and 11.33% of all subjects gave a *wrong or unsafe* answer. With $\chi^2=8.4509$, $df=6$, $p=0.207$, the Chi-Square test for *all subjects* did not indicate significant differences due to culture for pictogram 11. Additionally, no significant differences were found among paired groups or within the *highly stratified group*.

Pictogram 12 (ELECTRO2). Significant main effects for the influence of culture on the interpretation of pictogram 12 were suggested by the Chi-Square test for *all subjects* with $\chi^2=19.606$, $df=6$, $p=0.0033$. Pairwise comparisons showed a significant difference between the German and the U.S. groups at $p=0.0003$, between the French and the U.S. at $p=0.0413$, and between the British and the U.S. groups at $p=0.0197$. No other significant differences were observed. Figure 31 shows the percentages for *all subjects*.

The significant difference due to culture between the U.S. and the German groups were confirmed by the Chi-Square test for the *highly stratified group* at $\chi^2=11.300$, $df=4$, $p=0.0234$. No significant differences between any of the other groups were found.

Further analysis of the results supported the findings for pictogram 5 (ELECTRO1). Again, U.S. subjects did considerably more often (94.59%) give an *incomplete but safe* answer such as "No radios" than the German subjects (55.10%). Conversely, a significantly higher proportion of German subjects (40.82%) indicated the *complete and correct* answer "Do not use radios" than subjects from the U.S. group (5.41%). The results were consistent with the results for pictogram 5.

It was concluded that culture had a significant main effect on the interpretation of pictogram 12.

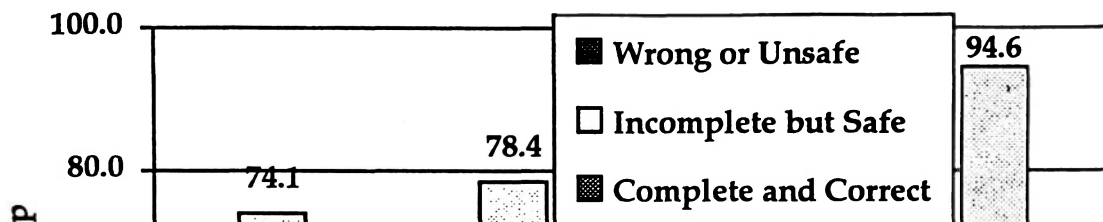

It was concluded that culture had a significant main effect on the interpretation of pictogram 12.

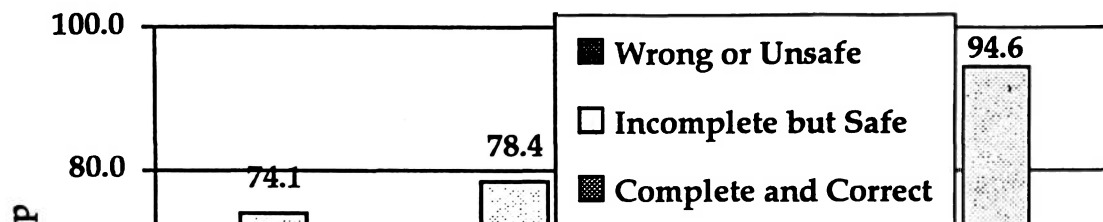

It was concluded that culture had a significant main effect on the interpretation of pictogram 12.

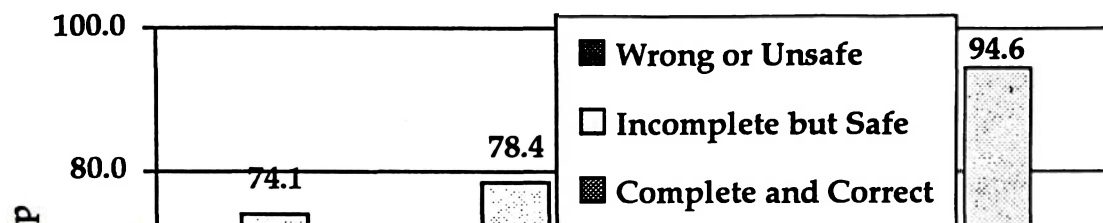

of pictogram 12.

It was concluded that culture had a significant main effect on the interpretation92

$p=0.3171$). Thus, it was concluded that culture had no significant effect on the interpretation of pictogram 13.

Other Influences on the Interpretation of Safety Cards

In separate Chi-Square tests, the subjects' interpretations of the symbols were investigated for significant main effects due to age, gender, field of study, or flight experience. The Chi-Square tests were conducted to determine whether the differences observed for the different cultures were related to the other factors.

Age. For 11 of the 13 pictograms, age had no significant main effect. The Chi-Square test showed a significant influence, however, for pictogram 4 (OXYGEN) and pictogram 8 (SLIDE2). With $\chi^2=7.8915$, $df=2$, $p=0.0193$, age was a main factor in the answers for pictogram 4. The 120 students under 30 gave with 95.3% more *complete and correct* answers than the 30 subjects 30 years of age or older (80%). With $\chi^2=9.0733$, $df=2$, $p=0.0107$, age also had a significant influence on the interpretation of pictogram 8. The group under 30 overall gave better answers than the older subjects. Since no significant differences between the cultures were found for the two pictograms, it was concluded that the influence of age did not interfere with those findings.

Gender. No significant influence of gender was found for any of the symbols in the test except for pictogram 6 (HEELS2). With $\chi^2=15.551$, $df=2$, $p=0.0004$, the 34 female subjects gave significantly less *correct and complete* answers than the 116 male test participants. A review of the test scores showed that the difference was due to the fact that women considerably less often specified that only high-heel shoes were to be removed. Instead, female subjects answered with a general "No shoes." A possible explanation for this result could be that the shoe depicted in pictogram 6 was not close enough to a realistic

representation of a high-heel shoe to be interpreted as such. HEELS2, however, was not found to be significantly influenced by culture. Thus, further analyses regarding this pictogram were not performed.

Field of Study. Of the 34 female subjects in the study, 28 studied in a field other than aeronautics. Therefore, the *aeronautics* group and the *other* group were strongly biased by gender. Since a highly significant difference was found between the genders in the interpretation of pictogram 6 (HEELS3), this difference was reflected in the significant influence between the aeronautics and the other group ($\chi^2=11.159$, $df=2$, $p=0.0038$). The field of study had no significant main effect on the interpretation of any other symbol.

Flight Experience. For two symbols, pictogram 8 (SLIDE2) and pictogram 9 (DITCH), previous flight experience had a significant main effect. Experience was found to influence the interpretations for SLIDE2 at $\chi^2=9.078$, $df=2$, $p=0.0107$. While 81% of the subjects with experience gave a *complete and correct* answer, only 60% of the subjects without experience did so. However, it must be noted that only 15 of the 150 subjects in the test had no previous flight experience as passenger. With $\chi^2=8.1346$, $df=2$, $p=0.0171$, experience also had an influence on the interpretation of pictogram 9 (DITCH). Again, the 15 subjects without flight experience gave significantly fewer correct answers than the 135 subjects with previous experience as an aircraft passenger. Subjects without experience mostly mistook the symbol for the depiction of a floatplane or as the capability of the aircraft to float. No significant influence of flight experience on the cultural comparisons were noted.

Summary

Significant main effects of culture on the interpretation and understanding of pictograms similar to those used on current safety cards were observed. For

five of the 13 presented symbol, culture had a significant influence between different groups at varying degrees. Hypothesis IV stated that the number of correct answers would vary between subjects according to their culture. Since significant variations were found for at least five of the 13 pictograms, Hypothesis IV was accepted.

Brief Comparison of the Overall Effectiveness of the Pictograms

Although not integral part of the cross-cultural study, the overall effectiveness of the symbols among all subjects was assessed. To give a brief comparison, mean scores were calculated. Although the raw scores were ordinal, it was assumed that an overall level of understanding could be represented by using mean scores (Figure 31). If all subjects had chosen a *complete and correct* answer, the mean score would be $M=+1.0$. Conversely, it would be $M=-1.0$, if all subjects in a group gave *wrong or unsafe* answers. For instructions which were represented by more than one symbol, brief comparisons were made.

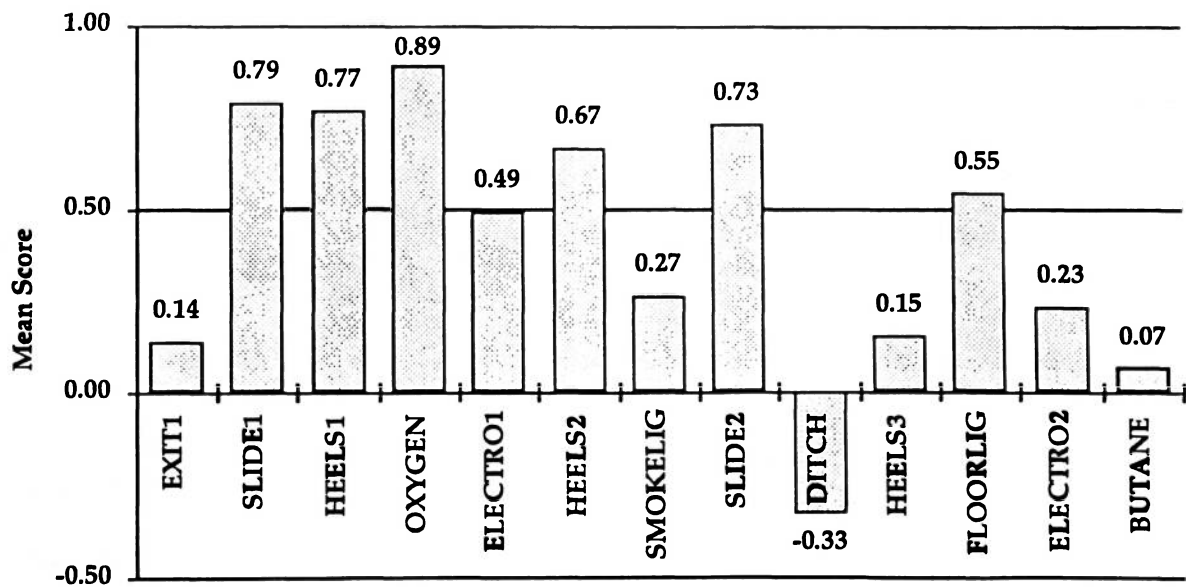
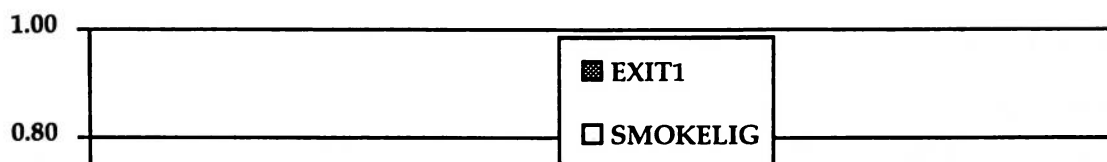

Figure 32. Interpretation of Pictograms. Overall Mean Scores for all Subjects.

Exit Lighting

Three pictograms (EXIT1, SMOKELIG, and FLOORLIG) depicted the lighted emergency exit floor path. Figure 33 shows the differences in the means for the three pictograms for *all subjects* and by culture.



Exit Lighting

Three pictograms (EXIT1, SMOKELIG, and FLOORLIG) depicted the lighted emergency exit floor path. Figure 33 shows the differences in the means for the three pictograms for *all subjects* and by culture.

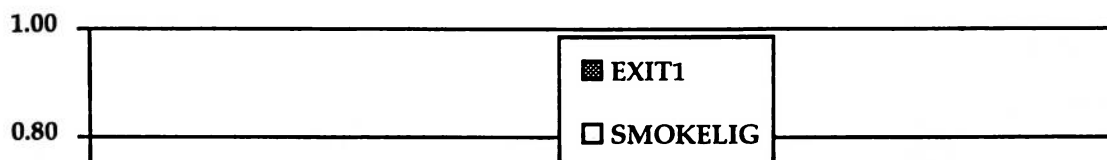

Exit Lighting

Three pictograms (EXIT1, SMOKELIG, and FLOORLIG) depicted the lighted emergency exit floor path. Figure 33 shows the differences in the means for the three pictograms for *all subjects* and by culture.

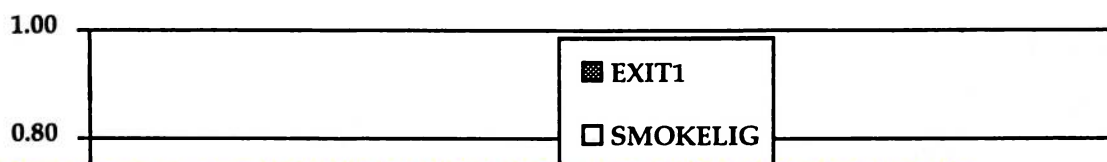

Three pictograms (EXIT1, SMOKELIG, and FLOORLIG) depicted the lighted emergency exit floor path. Figure 33 shows the differences in the means for the three pictograms for *all subjects* and by culture.

High Heel Shoes

Three pictograms (HEELS1, HEELS2, and HEELS3) displayed the instructions to remove high-heel shoes. Figure 34 shows the comparisons of mean scores by culture for the three symbols.

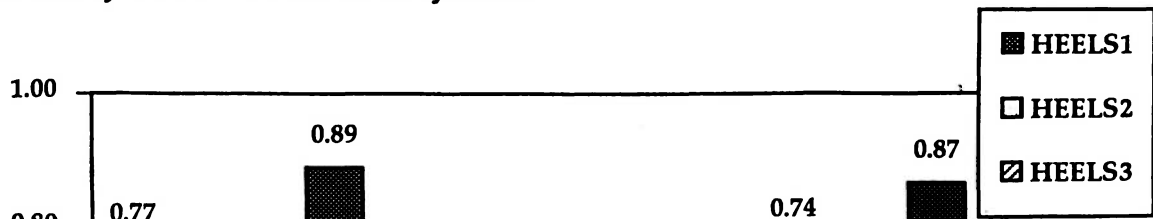

High Heel Shoes

Three pictograms (HEELS1, HEELS2, and HEELS3) displayed the instructions to remove high-heel shoes. Figure 34 shows the comparisons of mean scores by culture for the three symbols.

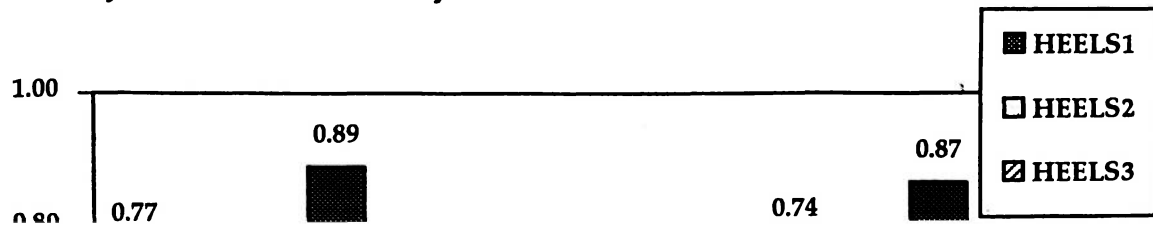

High Heel Shoes

Three pictograms (HEELS1, HEELS2, and HEELS3) displayed the instructions to remove high-heel shoes. Figure 34 shows the comparisons of mean scores by culture for the three symbols.

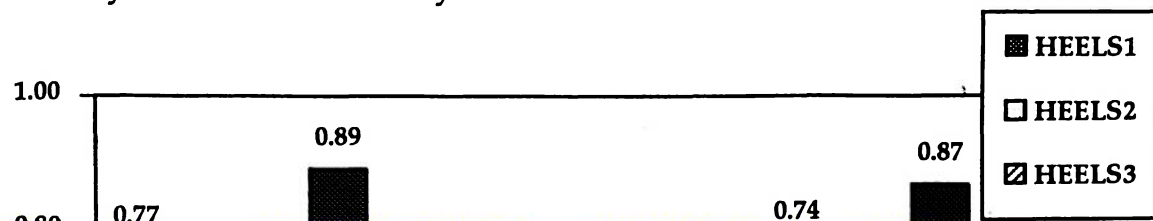

Three pictograms (HEELS1, HEELS2, and HEELS3) displayed the instructions to remove high-heel shoes. Figure 34 shows the comparisons of mean scores by culture for the three symbols.

shoes (*wrong or unsafe*). One reason could be the absence of an arrow (or a similar symbol) in HEELS3 which would have indicated the required direction of movement (i.e., to remove shoes).

Exit Slides

The correct and fastest way of using exit slides during an emergency evacuation was depicted in two pictograms. Both symbols (SLIDE1 and SLIDE2)

shoes (*wrong or unsafe*). One reason could be the absence of an arrow (or a similar symbol) in HEELS3 which would have indicated the required direction of movement (i.e., to remove shoes).

Exit Slides

The correct and fastest way of using exit slides during an emergency evacuation was depicted in two pictograms. Both symbols (SLIDE1 and SLIDE2)

shoes (*wrong or unsafe*). One reason could be the absence of an arrow (or a similar symbol) in HEELS3 which would have indicated the required direction of movement (i.e., to remove shoes).

Exit Slides

The correct and fastest way of using exit slides during an emergency evacuation was depicted in two pictograms. Both symbols (SLIDE1 and SLIDE2) similar symbol) in HEELS3 which would have indicated the required direction of movement (i.e., to remove shoes) shoes (*wrong or unsafe*). One reason could be the absence of an arrow (or a

Electronic Equipment

Figure 36 shows the different mean scores for the pictograms depicting the prohibition to use electronic equipment (ELECTRO1, ELECTRO2). Both pictograms were effective in that almost no *wrong or unsafe* answers were given, even if many subjects (especially from the U.S.) limited themselves towards answers such as "No radios." These answers suggested that the subjects thought that not only the use, but also the carriage of such equipment was not allowed.

99

Electronic Equipment

Figure 36 shows the different mean scores for the pictograms depicting the prohibition to use electronic equipment (ELECTRO1, ELECTRO2). Both pictograms were effective in that almost no *wrong or unsafe* answers were given, even if many subjects (especially from the U.S.) limited themselves towards answers such as "No radios." These answers suggested that the subjects thought that not only the use, but also the carriage of such equipment was not allowed.

99

Electronic Equipment

Figure 36 shows the different mean scores for the pictograms depicting the prohibition to use electronic equipment (ELECTRO1, ELECTRO2). Both pictograms were effective in that almost no *wrong or unsafe* answers were given, even if many subjects (especially from the U.S.) limited themselves towards answers such as "No radios." These answers suggested that the subjects thought that not only the use, but also the carriage of such equipment was not allowed.

Figure 36 shows the different mean scores for the pictograms depicting the prohibition to use electronic equipment (ELECTRO1, ELECTRO2). Both

99

Conclusions

The results of this study indicate that culture can have a significant main effect on the understanding and interpretation of safety information by passengers from different countries. A self-developed aviation safety test/questionnaire which focused on information found on aircraft passenger safety briefing cards was administered to students from three cultures in Western Europe and from the U.S. Significant culture-related differences at $p < 0.05$ were found.

The research hypotheses with respect to the understanding of the color coding used for exits in aircraft floor lighting was accepted. Significant differences were also found regarding the interpretation of symbols similar to those used on current aircraft passenger safety information cards. It was concluded that culture significantly influenced the subjects' answers in these areas.

Some of the hypothesized differences, however, were not observed. No general trend following the communication styles suggested by the literature could be identified in the design preferences for aircraft passenger safety cards. Still, significant variations were found among the cultures. These differences were between other groups than hypothesized.

In all but two cases, the significant differences existed between the U.S. group on one side, and the French and/or German groups on the other side. Additionally, all observed differences were at least between one of the two English-speaking groups (i.e., British or U.S.), and one of the groups from Continental Europe (i.e., French, German). This led to the conclusion that native language as one part of culture had a significant main effect. The British and U.S. groups only varied where a convention regarding the color

used for exit floor lighting was involved. In all other cases, there was no significant difference between the two groups. It was concluded that the British and the U.S. groups not only used the same language, but also shared other characteristics in communication style (e.g., a higher preference for photos as compared to the French and German groups).

In two cases, significant differences were found between the French and the German groups. No clear pattern could be observed. German answers were very detailed and longer than those from all other groups. This, however, did not induce significant differences in the correctness of the answers. It was concluded that the assumed strong differences in communication styles between the French and the German groups did not become apparent in the study, if they existed.

Interpretation of Pictograms

For five of the 13 pictograms presented to the subjects, significant differences in understanding and interpretation due to culture were found. The observed differences were mostly caused by a significantly higher number of incomplete or incorrect answers from the subjects in one group as compared to the other three groups. For three of the five pictograms, the U.S. group had significantly lower scores, resulting from very short answers or the absence of any answer.

One interpretation of these findings can be the short and to-the-point communication style of the English language. Short sentences and headline-type statements are preferred in the U.S. Thus, when interpreting the pictograms HEELS3, ELECTRO1, and ELECTRO2, short answers such as "No radios" or "No shoes" were preferred by U.S. (and to a certain extent, British) subjects. These answers were scored as *incomplete but safe*, since they did not

clarify what was exactly meant by the symbols, without giving a *wrong or unsafe* answer. Potential problems, however, could emerge for the instructions to remove high-heel shoes, where differences between the U.S. and the German group were observed. If all passengers take off their shoes during an emergency, possible dangers are delays, obstruction of the aisles and seat-rows with loose shoes, and the lack of protection of the passengers' feet against debris. These hazards might outweigh the advantages induced by the removal of high-heel shoes for the usage of the exit slide. It was concluded that the short U.S. interpretations could potentially have an impact on safety.

The same problem of answers that lacked precision was found for SLIDE1. German answers were in exhaustive detail regarding the need to use the slide as quickly as possible, but failed to mention the best way to do so (jump). Here, the long and complicated German style which resulted in high mean scores for other pictograms became counterproductive. Interestingly enough, German subjects mentioned jumping considerably more often for SLIDE2.

The interpretation of EXIT1 was the only case where a significant difference was found due to a high number of *wrong or unsafe* answers from one group. Many French subjects implied in their answers that the arrow used in the picture was actually installed in the aircraft. This was incorrect. The reason why many subjects in the French group gave this interpretation remained unclear.

For several safety-related areas, such as the usage of exit slides or removal of high-heel shoes, more than one pictogram was presented. It became apparent from the test scores that most pictograms were correctly interpreted by a large percentage of subjects. Some symbols, however, were recognized and understood better than others. One of the symbols for the

removal of high-heel shoes, for example, led to confusion among many passengers as to whether the symbol meant to take off or put on shoes. For the symbols prohibiting the use of certain electronic equipment, the subjects' answers showed a high proportion of literal interpretations: Only the depicted equipment was mentioned. It was concluded that the degree of subjects' understanding varied according to the quality of the symbol.

Safety Card Design Preferences

The results regarding design preferences for safety cards did not show the hypothesized differences between the German and the French groups based on varying communication styles. German and French subjects chose drawings and words at almost equal numbers. This indicated that the preferences among French and Germans suggested by the literature for advertisements were not significant for the preferred design of safety cards.

Drawings were a feature mentioned almost equally often by subjects from all cultures. It was concluded that drawings are a method of conveying safety information accepted by all cultures in the test.

U.S. subjects selected photos more often and with a higher priority than European subjects. These differences, however, were significant between the German and the U.S. group. It was concluded that photos were a design feature appealing to U.S. subjects, while unimportant to Germans.

Color Coding of Exits in Floor Lighting

As was hypothesized, European subjects indicated significantly more often than U.S. subjects that green was used as the color to denote an emergency exit in aircraft floor lighting. Conversely, red was mentioned by U.S. subjects significantly more often than by European subjects. The same

significant differences were found when the subjects were asked which color should be preferred to indicate exits: U.S. subjects chose red, while European subjects selected green. Only very few subjects from any culture mentioned any color other than green or red. These findings corroborated with the current color coding of exit signs in buildings. In the U.S., exit signs are red, while green is used in wide parts of Europe. It was concluded that the answers varied significantly due to the subjects' previous experiences.

The results of this part of the study are in agreement with general principles of cross-cultural communication suggested by the reviewed literature. Bertin (1983) stated that "*the meaning of a symbol becomes familiar to us only by habit; through the repetition of a similar situation*" (p. 95). In a specialized field such as the use of colors to denote exits, the employed code must be learned to correctly interpret the symbol. If the code varies from one culture to another, it must be expected that the interpretation of the respective symbol differs according to culture.

The findings from the test suggest that a European passenger who is caught in an aircraft accident might search for green lights in the floor path. Based upon previous experience, the passenger might believe that green indicates the exit, even when – on a U.S. plane – the exits are marked in red. The passenger would probably not be able to identify the location of exits and thus might perish in the wreckage. The reverse situation would be true of a U.S. passenger aboard a plane that has an emergency floor path installed which uses green as the color to denote an exit. It was therefore concluded that the current status of employing varying colors in different countries to denote emergency exits could result in potentially dangerous confusion among the passengers as to how an exit is actually marked.

Summary

Significant differences due to culture could be observed between the subjects for several of the investigated areas. This finding is important since it gives empirical evidence to the hypothesis that the understanding of safety-related information can vary with culture. Once these differences are investigated and documented, it will be possible to begin research into the development of a safety information format that is equally effective for subjects from different cultures.

Throughout the study, all possible precautions were taken to avoid Type I errors, i.e., the statement that a significant difference due to culture existed, when, in fact, there was none. It was felt by the researcher that this procedure would add weight to the findings in those areas where significant differences were observed. A very strict method for the analysis of data was used. Direct pairwise Chi-Square tests would have probably shown significant differences between more groups and for more questions. A highly stratified control group was used to confirm the results found for all subjects. Thus, the researcher took the risk to commit Type II errors, i.e., to state that there was no significant difference when there was one. Still, significant culture-induced differences were observed.

Furthermore, the differences were found between subjects from four cultural areas which share a long history and many common concepts. All subjects came from highly industrialized Western Democracies. All subjects were university students. Yet, even between those subjects of the same age, gender, and experience that studied in the same, test-related field, significant differences were observed.

Aircraft passenger safety briefing cards are an important part of safety precautions in aviation. Previous experience has shown that the cards help to save lives during aircraft accidents. Thus, they must be understood by all readers, regardless of age, gender, previous experience, or culture. The results of this study led to the conclusion that cultural differences must be taken into account when designing aircraft passenger safety information.

Recommendations

General Recommendations

The test showed significant differences due to culture in the understanding and interpretation of certain passenger safety information. These differences were found between subjects from Western Europe and the U.S., relatively similar societies. It can only be assumed to what extent the differences would grow in scale and severeness, if subjects from more distinct cultures were selected. Therefore, one recommendation is to test safety cards internationally among subjects from different cultural areas.

Recommendation I

Test at least those safety briefing cards used on international flights for their effectiveness among subjects from different cultures to determine whether the cards are significantly less effective for particular cultures than for others. Preferably, test in many different countries, but use at least subjects from the countries of departure and arrival.

Recommendation II

As one step towards more international testing, replicate this study with subjects from Asia, Africa, and Latin America, to determine whether greater differences exist between cultures that do not share the same geographical or historical background. Target populations could include China, Japan, Argentina, or Kenya.

Since the differences between the cultures were observed using the conceptual test method, it can only be assumed whether the subjects would

act differently in an emergency according to their answers. Cross-cultural differences might even be more pronounced when the subjects have to perform the necessary tasks.

Recommendation III

In follow-up tests, use the behavioral test method to investigate the influence of cross-cultural differences on the understanding and interpretation of passenger safety information. Employ the conceptual test method to identify symbols that have different meanings to subjects from different cultures. Then, using these symbols, test whether the differences found in the conceptual tests have a significant influence on subjects' behavior.

Recommendations for Test Procedures

During the analysis of the data, several shortcomings of the study due to the selection of subjects became apparent. A broad approach was used to test for as many different areas of interpretation of safety information as possible. The subjects in the test varied according to four extraneous variables which were unevenly distributed across the cultures. As a result, a *highly stratified* group had to be used as a control group, introducing the chances of committing Type II errors into the study. Therefore, the following measures are recommended for follow-up studies.

Recommendation IV

Use test groups that are either representative of the respective population, or limit the number of extraneous variables as much as possible. The second option, however, increases the chances for Type II errors.

Recommendation V

When using the same approach of using entire classes from universities for the test, amend the test instructions so that only native students should complete the test. All non-native subjects were removed from the analysis which reduced the number of subjects in one group (British, subgroup I, Cranfield) considerably.

Recommendation VI

This study used a broad approach, testing in several areas of interpretation and understanding of safety cards. For follow-up studies, test only one area (e.g., high-heel shoes) at one time, but in more detail.

Recommendations for Safety Card Design

According to the results of the extended tests, an international standard for safety cards should be developed. Instructions that are effective for one culture might be ineffective in another culture. Standardized instructions at an optimum overall level could aid towards familiarity with the procedures among all readers. They could also help people from different cultures in understanding the information without the need for translation, alleviating problems of confusion due to changing instructions.

Standardization also has the advantage of lower cost. An effective safety card would be developed once, and only the details regarding a particular airplane would change. This would save cost, and allow air carriers from less wealthy countries to acquire effective safety briefing cards.

Recommendation VII

If indicated by the extended cross-cultural tests, develop an international standard regarding safety cards. The standard should include guidelines regarding the size, format, color, etc. of the cards. Furthermore, details with respect to the way safety information is depicted should be given.

Some of the design feature questions indicated that drawings were acceptable to and desired by most subjects in the test. In previous studies (e.g., Johnson, 1980), drawings were found to be more effective than photos, since they reduced visual clutter and allowed emphasis of certain, important parts of the picture. Some of the pictograms were recognized and interpreted more correctly by all subjects than others.

Recommendation VIII

As a first step towards standardization, make the use of drawings to convey safety information mandatory. Then, select those symbols and pictograms that showed a high level of recognition among subjects from all cultures and standardize them.

Recommendations Regarding Specific Pictograms

The symbols used to convey the instruction to remove high heel shoes were recognized at varying degrees. HEELS3 was particularly confusing to some subjects who did not know whether the symbol meant to remove or to wear shoes.

Recommendation IX

Amend the symbol HEELS3 with an arrow showing the direction of movement away from the foot.

The subjects' interpretation of the symbols showing the prohibition to use electronic equipment aboard the airplane was very literal. The subjects mentioned only the type of equipment actually depicted on the cards.

Recommendation X

Amend the pictograms depicting the prohibition to operate certain electronic equipment as to which equipment shall not be used. Consider removal of the symbol from the safety card, since this instruction is not directly related to the safety procedures for the case of an aircraft accident. Consider combining this information with others such as no smoking on a separate instruction sheet which the passengers could receive with their ticket or boarding pass.

Recommendations Regarding Exit Path Lighting

Several of the questions in this study were connected to emergency exit floor path lighting. Three pictograms (EXIT1, SMOKELIG, and FLOORLIG) showed different depictions of the guidance system. Two questions centered around the color-coding of exits in the floor lighting.

The findings of this study with respect to the color-coding of exits are important to aircraft passenger safety. The location of emergency exits is a critical step in survival after aircraft accidents. Previous aircraft accidents showed that people died because they were not able to find the exit in a smoke-filled cabin. Two passengers were killed in 1983 during the post-

accident fire of a twin-jet at the Greater Cincinnati International Airport because they could not locate the overwing emergency exit (NTSB, 1986). The survivors of this accident indicated that they had severe difficulties to find the exit. This airplane had no emergency floor lighting, and the only hints that the survivors used to locate the exit were a dim glow of light or a draft of air. As a result of this accident, the emergency floor path marking was introduced in the U.S.

In 1991, the researcher had the opportunity to participate in evacuation trials from the cabin safety simulator at the Civil Aeromedical Institute (CAMI) in Oklahoma City, Oklahoma. Even without any heat or toxic fumes present from a fire, with the emergency floor path installed, and with the researcher being informed about the path, it was difficult to locate the exit in a cabin filled with non-toxic smoke. If the confusion in a real emergency evacuation, the heat, smoke, and toxic fumes from a real fire are added to the situation, the location of the exit could become a very demanding task for the average passenger, even without the added confusion as to whether the exit floor path is colored red or green.

It has been suggested by the literature that there are symbols that are more universally accepted than others, either because they are intuitively obvious to the observer, or because a certain familiarity has been built across cultures (Bertin, 1983). One example is the use of colors in traffic signals. Across the world, red means "Stop" in traffic lights, while green means "Go." It can be assumed that the majority of aircraft passengers is exposed to this color code on a daily basis. As has been stated earlier, humans tend to revert to old habits and learned behavior when confronted with a high-stress situation. Thus, passengers who did not previously learn which color was used to mark an exit would probably transfer their experiences from surface

travel to aviation. They would think that a green light indicated a clear path to proceed across the lights and towards the exit. Conversely, confronted with red lights, they might conclude that they should not cross the signal because greater danger was behind it.

The respective U.S. regulation for *floor proximity emergency escape path marking* can be found in FAR 25.812 (e) (DoT, 1992). While the colors for emergency exit signs are stipulated as red letters on white surface, no specifications as to color are made for the identification of the exits in the floor path. Therefore, any color could be chosen without changing the regulations. Since the researcher believes that it would add to safety to standardize the exit coding, preferably to the more intuitive green, the following recommendations were made.

Recommendation XI

As long as there is no standard as to which color is used, emphasize the color used in a particular aircraft in all passenger information. Amend safety briefing cards, crewmember briefings, and videotape instructions, if necessary, to point out which color denotes an exit.

Recommendation XII

Develop an international standard for the use of colors in denoting exits. Test green for its effectiveness; if effective with respect to legibility, contrast, acceptance, etc., implement green in all aircraft.

Recommendation XIII

Color coding would not be necessary if the path itself showed the exits by turning towards it, similar to the arrow presumed to be installed by some

subjects in the French group. Install a guidance path which leads directly to the exit, and color coding is no longer important.

References

- Air Transport Association of America (ATA), Airport Operators Council International (AOCI), & American Association of Airport Executives (AAAE). (1985). *Guidelines for airport signing and graphics*. Washington, DC: ATA.
- Altman, H. (1974a). Aircraft passenger education. *SAFE Journal*, (3), 9.
- Altman, H. (1974b). *The use of pictorial materials in aircraft passenger safety instruction*. Doctoral Dissertation. Claremont Graduate School.
- Altman, H. (1975a). Some highlights of aircraft passenger research. *Aviation, Space, and Environmental Medicine*, (1), 89-91.
- Altman, H. (1975b). Corporate/executive aircraft passenger safety – An educational approach. *SAFE Journal*, 5, 7-11.
- Altman, H., Johnson, D., & Blom, D. (1970). Passenger emergency evacuation cards – Recommendations for presentation style. *Proceedings of the 8th Annual Symposium of the Survival and Flight Equipment Association (SAFE)*, 455-474.
- Barnard, P., & Marcel, A. (1983). Representation and understanding in the use of symbols and pictograms. In R. Easterby & H. Zwaga (Eds.), *Information Design*. Chichester, UK: John Wiley & Sons.
- Barthelmes, S. (1985). *Survival factors*. Oklahoma City: Transportation Safety Institute.
- Bertin, J. (1983). *Semiology of graphics*. Madison, WI: University of Wisconsin Press.
- Brooks, H. (1986, December 21). Being in the red is good for the business. *The Olympian*, Olympia, WA.
- Bundesverkehrsministerium. (1987). *Anhang zur 1. Durchführungsverordnung zur LuftBetriebsordnung, § 10*. Bonn, Germany: Author.
- Casse, P. (1981). *Training for the cross-cultural mind – A handbook for cross-cultural trainers and consultants*. Washington, DC: The Society for Intercultural Education, Training and Research (SETAR).
- Collins, B. (1982). *The development and evaluation of effective symbol signs* (Report No. NSB Building Science Series 141). Washington, DC: National Bureau of Standards (NSB).
- Comair. (1990). *Exit row seating* (Form No. Comair FO-0192, 10/90).

- Cook, T., & Smith, D. (1980). Communications – complex problem solving: Design and development of a signage system for the Columbus international airport in Columbus, Ohio. *Proceedings of the Symposium on Human Factors and Industrial Design in Consumer Products*, 329-341.
- Department of Transportation (DoT). (1977). *Aviation instructor's handbook* (Advisory Circular AC60-14). Washington, DC: Government Printing Office.
- Department of Transportation (DoT). (1989). *Passenger safety information and briefing cards* (Advisory circular AC121-24A). Washington, DC: Government Printing Office.
- Department of Transportation (DoT). (1992). *Code of federal regulations, title 14*. Washington, DC: Government Printing Office.
- Dreyfuss, H. (1970). *Visual communications: A study of symbols* (SAE Transactions, Vol. 79). Warrendale, PA: Society of Automotive Engineers (SAE).
- Dwyer, F. (1967). Adapting visual illustrations for effective learning. *Harvard Educational Review*, 37, 250-263.
- Edwards, M. (1990). *The aircraft cabin: Managing the human factors*. Aldershot, UK: Gower Technical.
- Gay, R. (1987). *Educational research: Competencies for analysis and application* (3rd ed.). Columbus, OH: Merrill Publishing.
- Goldstein, A. (1990). *Flying out of danger – A pilot's guide to air safety*. Long Beach, CA: Airguide Publications.
- Green, P., & Pew, R. (1978). Evaluating pictographic symbols: An automotive application. *Journal of the Human Factors Society*, 20 (1), 103-114.
- Hall, E. (1977). *Beyond culture*. Garden City, NY: Anchor Press/Doubleday.
- Hall, E., & Hall, M. (1990). *Understanding cultural differences*. Yarmouth, ME: Intercultural Press.
- Heard, E. (1974). *Symbol study – 1972*. Warrendale, PA: Society of Automotive Engineers (SAE).
- Johnson, D. (1972). Behavioral inaction under stress conditions. *SAFE Engineering*, 2, 13-19.

- Johnson, D. (1980). The design of effective safety information displays. *Proceedings of the Symposium on Human Factors and Industrial Design in Consumer Products*, 314-328.
- Johnson, D. (1984). *Just in case*. New York, NY: Plenum Press.
- Johnson, D. (1985). Passenger self-help programs. In *Proceedings of the Cabin Safety Conference and Workshop 1984* (Report No. DoT/FAA/ASF100-85/01) (pp. 142-148). Washington, DC: Government Printing Office.
- Johnson, D., & Altman, H. (1973). Effects of briefing card information on passenger behavior during aircraft evacuation demonstrations. *Proceedings of the Human Factors Society – 17th Annual Meeting*, 215-221.
- Johnson, D., Blom, D., & Altman, H. (1975). Video tape presentation of passenger safety information. *Proceedings of the Human Factors Society – 19th Annual Meeting*, 102-107.
- Lanier, A. (1973). *Living in Europe*. New York: Charles Scribner's Sons.
- Lufthansa Jahrbuch*. (1987). Cologne, Germany: Deutsche Lufthansa.
- Lufthansa Jahrbuch*. (1990). Cologne, Germany: Deutsche Lufthansa.
- Lundstrom, R. (1988, July). Taking safety to the passenger. *Commuter Air*, 38-39.
- Mangan, J. (1978). Cultural conventions of pictorial representation: Iconic literacy and education. *Educational Communications & Technology*, 26 (3), 245-267.
- Miller, R. (1973). Cross-cultural research in the perception of pictorial materials. *Psychological Bulletin*, 80 (2), 135-150.
- Morain, G. (1987). Kinesics and cross-cultural understanding. In L. Luce (Ed.), *Toward internationalism – Readings in cross-cultural communication* (pp. 117-142). Cambridge, MA: Newbury House.
- National Transportation Safety Board (NTSB). (1985). *Safety study – Airline passenger safety education: A review of methods used to present safety information* (Report No. NTSB/SS-85/09). Springfield, VA: National Technical Information Service (NTIS).
- National Transportation Safety Board (NTSB). (1985). *Aircraft accident report – Air Canada flight 797, McDonnell Douglas DC-9-32, C-FTLU, June 2, 1983* (Report No. NTSB/AAR-86/02). Springfield, VA: NTIS.
- Osborne, D. (1987). *Ergonomics at work*. New York: John Wiley & Sons.

- Paajanen, R. (1991). *MD-11 safety card test*. (Unpublished Report). Helsinki, Finland: Finnair Flight Department.
- Parker, E. (1988). *Illustrating instructional materials: An international perspective*. (Reprint from *Training & Development Journal*). Alexandria, VA: American Society for Training and Development.
- Reber, A. (1985). *The penguin dictionary of psychology*. New York: Viking Penguin.
- Schmidt, J., & Kysor, K. (1987). Designing airline passenger safety cards. *Proceedings of the Human Factors Society – 31st Annual Meeting*, 51-55.
- Schneller, R. (1989). Intercultural and intrapersonal processes and factors of misunderstanding: Implications for multicultural training. *International Journal of Intercultural Relations*, 13, 465-484.
- Sinaiko, W., Guthrie, G., & Abbott, P. (1969). *Operating and maintaining complex military equipment: A study of training problems in the republic of Vietnam* (Extracts taken from Research Paper P-501). Institute for Defense Analyses – Science and Technology Division.
- Stewart-Morris, M. (1991, July). *Human factors in aircraft accident investigation*. Presentation at the Transportation Safety Institute, Oklahoma City.
- Taylor, L. (1989). *Air travel – How safe is it?* Oxford: BSP Professional Books.
- Taylor, S. (1990). *Culture shock! France*. Singapore: Times Books International.

APPENDIX A

FAR PART 121.571 AND FAR PART 121.585 (d) AND (e)

§ 121.571 Briefing passengers before take off.

(a) Each certificate holder operating a passenger-carrying airplane shall insure that all passengers are orally briefed by the appropriate crewmember as follows:

(1) Before each takeoff, on each of the following:

(i) *Smoking.* Each passenger shall be briefed on when, where, and under what conditions smoking is prohibited (including, but not limited to, the pertinent requirements of Part 252 of this title). This briefing shall include a statement that the Federal Aviation Regulations require passenger compliance with the lighted passenger information signs and posted placards. The briefing shall also include a statement that Federal law prohibits tampering with, disabling, or destroying any smoke detector in an airplane lavatory.

(ii) The location of emergency exits.

(iii) The use of safety belts including instructions on how to fasten and unfasten the safety belt.

(iv) The location and use of any required emergency flotation means.

(2) After each takeoff, immediately before or immediately after turning the seat belt sign off, an announcement shall be made that passengers should keep their seat belts fastened, while seated, even when the seat belt sign is off.

(3) Except as provided in paragraph (a)(4) of this section, before each takeoff a flight attendant assigned to the flight shall conduct an individual briefing of each person who may need the assistance of another person to move expeditiously to an exit in the event of an emergency. In the briefing the flight attendant shall—

(i) Brief the person and his attendant, if any, on the routes to each ap-

propriate exit and on the most appropriate time to begin moving to an exit in the event of an emergency; and

(ii) Inquire of the person and his attendant, if any, as to the most appropriate manner of assisting the person so as to prevent pain and further injury.

(4) The requirements of paragraph (a)(3) of this section do not apply to a person who has been given a briefing before a previous leg of a flight in the same aircraft when the flight attendants on duty have been advised as to the most appropriate manner of assisting the person so as to prevent pain and further injury.

(b) Each certificate holder shall carry on each passenger-carrying airplane, in convenient locations for use of each passenger, printed cards supplementing the oral briefing and containing—

(1) Diagrams of, and methods of operating, the emergency exits; and

(2) Other instructions necessary for use of emergency equipment.

Each card required by this paragraph must contain information that is pertinent only to the type and model airplane used for that flight.

(c) The certificate holder shall describe in its manual the procedure to be followed in the briefing required by paragraph (a) of this section.

[Amdt. 121-2, 30 FR 3206, Mar. 9, 1965, as amended by Amdt. 121-30, 32 FR 13268, Sept. 20, 1967; Amdt. 121-84, 37 FR 3975, Feb. 24, 1972; Amdt. 121-133, 42 FR 18394, Apr. 7, 1977; Amdt. 121-144, 43 FR 22648, May 25, 1978; Amdt. 121-146, 43 FR 28403, June 29, 1978; Amdt. 121-196, 53 FR 12362, Apr. 13, 1988]

Note. From *Code of Federal Regulations, Title 14, 1992*, Washington, DC: U.S. Government Printing Office.

§121.585 Exit row seating.

(d) Each certificate holder shall include on passenger information cards, presented in the languages used by the certificate holder for passenger information cards, at each seat affected by this section, information that, in the event of an emergency in which a crew member is not available to assist, a passenger occupying an exit row seat may use if called upon to perform the following functions:

- (1) Locate the emergency exit;
- (2) Recognize the emergency exit opening mechanism;
- (3) Comprehend the instructions for operating the emergency exit;
- (4) Operate the emergency exit;
- (5) Assess whether opening the emergency exit will increase the hazards to which passengers may be exposed;
- (6) Follow oral directions and hand signals given by a crewmember;
- (7) Stow or secure the emergency exit door so that it will not impede use of the exit;
- (8) Assess the condition of an escape

slide, activate the slide, and stabilize the slide after deployment to assist others in getting off the slide;

(9) Pass expeditiously through the emergency exit; and

(10) Assess, select, and follow a safe path away from the emergency exit.

(e) Each certificate holder shall include on passenger information cards, presented in the languages used by the certificate holder for passenger information cards, at all seats affected by this section, the selection criteria set forth in paragraph (b) of this section, and a request that a passenger identify himself or herself to allow reseating if he or she:

- (1) Cannot meet the selection criteria set forth in paragraph (b) of this section;
- (2) Has a nondiscernible condition that will prevent him or her from performing the applicable functions listed in paragraph (d) of this section;
- (3) May suffer bodily harm as the result of performing one or more of those functions; or,
- (4) Does not wish to perform those functions.

Note. From *Code of Federal Regulations, Title 14, 1992*, Washington, DC: U.S. Government Printing Office.

APPENDIX B
FAR PART 135.117 AND FAR PART 135.129 (d) AND (e)

§ 135.117 Briefing of passengers before flight.

(a) Before each takeoff each pilot in command of an aircraft carrying passengers shall ensure that all passengers have been orally briefed on—

(1) *Smoking.* Each passenger shall be briefed on when, where, and under what conditions smoking is prohibited (including, but not limited to, the pertinent requirements of part 252 of this title). This briefing shall include a statement that the Federal Aviation Regulations require passenger compliance with the lighted passenger information signs (if such signs are required) and posted placards. The briefing shall also include a statement (if the aircraft is equipped with a lavatory) that Federal law prohibits tampering with, disabling, or destroying any smoke detector installed in an aircraft lavatory.

(2) Use of seat belts;

(3) The placement of seat backs in an upright position before takeoff and landing;

(4) Location and means for opening the passenger entry door and emergency exits;

(5) Location of survival equipment;

(6) If the flight involves extended overwater operation, ditching procedures and the use of required flotation equipment;

(7) If the flight involves operations above 12,000 feet MSL, the normal and emergency use of oxygen; and

(8) Location and operation of fire extinguishers.

(b) Before each takeoff the pilot in command shall ensure that each person who may need the assistance of

another person to move expeditiously to an exit if an emergency occurs and that person's attendant, if any, has received a briefing as to the procedures to be followed if an evacuation occurs. This paragraph does not apply to a person who has been given a briefing before a previous leg of a flight in the same aircraft.

(c) The oral briefing required by paragraph (a) of this section shall be given by the pilot in command or a crewmember.

(d) Notwithstanding the provisions of paragraph (c) of this section, for aircraft certificated to carry 19 passengers or less, the oral briefing required by paragraph (a) of this section shall be given by the pilot in command, a crewmember, or other qualified person designated by the certificate holder and approved by the Administrator.

(e) The oral briefing required by paragraph (a) shall be supplemented by printed cards which must be carried in the aircraft in locations convenient for the use of each passenger. The cards must—

(1) Be appropriate for the aircraft on which they are to be used;

(2) Contain a diagram of, and method of operating, the emergency exits; and

(3) Contain other instructions necessary for the use of emergency equipment on board the aircraft.

(f) The briefing required by paragraph (a) may be delivered by means of an approved recording playback device that is audible to each passenger under normal noise levels.

[Doc. No. 16097, 43 FR 46783, Oct. 10, 1978, as amended by Amdt. 135-9, 51 FR 40709,

Note. From *Code of Federal Regulations, Title 14, 1992*, Washington, DC: U.S. Government Printing Office.

§ 135.129 Exit row seating.

(d) Each certificate holder shall include on passenger information cards, presented in the languages used by the certificate holder for passenger information cards, at each seat affected by this section, information that, in the event of an emergency in which a crewmember is not available to assist, a passenger occupying an exit row seat may be called upon to perform the following functions:

- (1) Locate the emergency exit;
- (2) Recognize the emergency exit opening mechanism;
- (3) Comprehend the instructions for operating the emergency exit;
- (4) Operate the emergency exit;
- (5) Assess whether opening the emergency exit will increase the hazards to which passengers may be exposed;
- (6) Follow oral directions and hand signals given by a crewmember;
- (7) Stow or secure the emergency exit door so that it will not impede use of the exit;
- (8) Assess the condition of an escape slide, activate the slide, and stabilize

the slide after deployment to assist others in getting off the slide;

(9) Pass expeditiously through the emergency exit; and

(10) Assess, select, and follow a safe path away from the emergency exit.

(e) Each certificate holder shall include on passenger information cards, presented in the languages used by the certificate holder for passenger information cards, at all seats affected by this section, the selection criteria set forth in paragraph (b) of this section, and a request that a passenger identify himself or herself to allow re-seating if her or she:

- (1) Cannot meet the selection criteria set forth in paragraph (b) of this section;
- (2) Has a nondiscernible condition that will prevent him or her from performing the applicable functions listed in paragraph (d) of this section;
- (3) May suffer bodily harm as the result of performing one or more of those functions; or,
- (4) Does not wish to perform those functions.

Note. From *Code of Federal Regulations, Title 14, 1992*, Washington, DC: U.S. Government Printing Office.

APPENDIX C
SAFETY CARD SAMPLE - DATA

Airline	Aircraft Type	Country	Year	Diagrams	Diagrams & (Words)	Words & (Diagrams)	Words	Photos	Color	Multiple Languages	Translated Instructions	Over-wing Exit Door	Shoes
Euroberlin France	B737	France	1988	1	0	0	0	0	1	0	0	2	2
Hapag-Lloyd	A310-300	Germany	N/A	0	1	0	0	0	1	1	1	0	1
Hapag-Lloyd	A310-300	Germany	N/A	0	1	0	0	0	1	1	1	0	1
LTU	MD-11	Germany	N/A	0	1	0	0	0	1	1	1	0	1
Lufthansa	A300	Germany	1989	0	1	0	0	0	1	1	1	0	1
Lufthansa	A300	Germany	1990	0	1	0	0	0	1	1	1	0	1
Lufthansa	A310	Germany	1989	0	1	0	0	0	1	1	1	0	1
Lufthansa	A320	Germany	N/A	1	0	0	0	0	1	1	0	2	1
Lufthansa	B737	Germany	1989	0	1	0	0	0	1	1	1	2	1
Lufthansa	B747	Germany	1990	1	0	0	0	0	1	1	0	0	1
Lufthansa	B747	Germany	1989	0	1	0	0	0	1	1	1	0	1
Lufthansa	DC-10	Germany	N/A	1	0	0	0	0	1	1	0	0	1
Cathay Pacific	B747-300	Hong Kong	N/A	1	0	0	0	0	1	0	0	0	2
Icelandair	B757-200	Iceland	N/A	1	0	0	0	0	1	1	0	3	2
Garuda Indonesia	A300 B4-220	Indonesia	N/A	1	0	0	0	0	1	1	1	0	2
Luxair	B737-200	Luxemburg	N/A	0	1	0	0	0	1	1	1	3	2
KLM	B747	Netherlands	1985	1	0	0	0	0	1	0	0	0	2
Air Portugal	B737-200	Portugal	1983	1	0	0	0	0	1	1	0	2	2
Singapore Airlines	A310	Singapore	N/A	1	0	0	0	0	1	0	0	0	2
Singapore Airlines	B747-400	Singapore	N/A	1	0	0	0	0	1	0	0	0	2
Swissair	B747	Switzerland	1990	0	0	0	0	1	1	0	0	0	2
Swissair	F100	Switzerland	1990	0	0	0	0	1	1	0	0	0	2
British Airways	B747-400	U.K.	N/A	1	0	0	0	0	1	1	0	0	2
Air Berlin USA	B737-300	U.S.A.	N/A	1	0	0	0	0	1	1	1	3	0
American	B727-223	U.S.A.	N/A	0	0	0	0	1	1	0	0	1	0
American	Super 80	U.S.A.	1987	0	0	0	0	1	1	0	0	4	0
Continental	A300	U.S.A.	1990	1	0	0	0	0	1	1	1	0	2
Continental	B727-100	U.S.A.	1988	1	0	0	0	0	1	1	1	1	2
Continental	B727-200	U.S.A.	1990	1	0	0	0	0	1	1	1	1	2
Continental	B737-200/300	U.S.A.	1987	1	0	0	0	0	1	1	1	1	2
Continental	DC-9-30	U.S.A.	1989	1	0	0	0	0	1	1	1	1	2
Continental	DC-9-80	U.S.A.	1987	1	0	0	0	0	1	1	0	1	2
Continental	DC-9-80	U.S.A.	1990	1	0	0	0	0	1	1	0	1	2
Delta	A310-200/300	U.S.A.	1991	0	0	1	0	0	1	1	1	0	0
Delta	B727-200	U.S.A.	1990	0	0	1	0	0	1	1	1	3	2
Delta	B737-200/300	U.S.A.	1990	0	0	1	0	0	1	1	1	3	2
Delta	B757	U.S.A.	1990	0	0	1	0	0	1	1	1	3	2
Delta	B767-300	U.S.A.	1990	0	0	1	0	0	1	1	1	3	2
Delta	B767-300ER	U.S.A.	1990	0	0	1	0	0	1	1	1	3	2
Delta	DC-9-32	U.S.A.	1990	0	0	1	0	0	1	1	1	3	2
Delta	L-1011	U.S.A.	1990	0	0	1	0	0	1	1	1	0	2
Delta	MD-11	U.S.A.	1991	0	0	1	0	0	1	1	1	0	2
Delta	MD-88	U.S.A.	1990	0	0	1	0	0	1	1	1	3	2

(Continued on Next Page)

Note. Explanation of Coding:

- Year: N/A: Unknown
- Design Features: 0: Not Used 1: Used on Card
- Over-wing Exit Door: 0: Not Mentioned 1: On Seats in Front 2: Outside 3: On Seats in Exit Row 4: On Seats Behind
- Shoes: 0: Not Mentioned 1: Remove All Shoes 2: Remove High-Heels Shoes

(Continued from Previous Page)

Airline	Aircraft Type	Country	Year	Diagrams	Diagrams & (Words)	Words & (Diagrams)	Words	Photos	Color	Multiple Languages	Translated Instructions	Over-wing Exit Door	Shoes
Eastern	B727-200	U S A	1990	0	0	0	0	1	1	1	1	3	2
Eastern	DC-9-31	U S A	1990	0	0	0	0	1	1	1	1	3	2
Eastern	DC-9-32	U S A	1990	0	0	0	0	1	1	1	1	3	2
Eastern	DC-9-51	U S A	1990	0	0	0	0	1	1	1	1	3	2
Northwest	B727-100	U S A	N/A	0	0	0	0	1	0	0	0	0	0
Northwest	B727-200	U S A	1989	0	0	0	0	1	0	0	0	0	0
Northwest	B727-200	U S A	1991	0	0	0	0	1	0	1	0	1	0
Northwest	DC-9-30/50	U S A	N/A	0	0	0	0	1	0	0	0	2	0
Pan Am	A310	U S A	1990	0	1	0	0	0	1	1	1	0	2
Pan Am	B727	U S A	1990	0	1	0	0	0	1	1	1	3	2
Pan Am	B727	U S A	N/A	1	0	0	0	0	1	1	1	3	2
Southwest	B737	U S A	1990	1	0	0	0	0	1	0	0	4	2
TWA	B727-231	U S A	1981	1	0	0	0	0	1	0	0	0	0
TWA	B727-31	U S A	1981	1	0	0	0	0	1	0	0	0	0
TWA	B747	U S A	1988	1	0	0	0	0	1	0	0	0	0
TWA	B767	U S A	1991	0	0	0	0	1	1	0	0	0	0
TWA	B767	U S A	1988	1	0	0	0	0	1	0	0	0	0
TWA	DC-9-80	U S A	1989	1	0	0	0	0	1	0	0	0	0
TWA	DC-9-80	U S A	1990	1	0	0	0	0	1	0	0	0	0
TWA	DC-9-80	U S A	1991	0	0	0	0	1	1	0	0	2	0
TWA	L-1011	U S A	1987	1	0	0	0	0	1	0	0	0	0
TWA	L-1011	U S A	1991	0	0	0	0	1	1	0	0	0	0
TWA	L-1011-100	U S A	1987	1	0	0	0	0	1	0	0	0	0
U S Air	B737-200/300	U S A	1990	1	0	0	0	0	1	1	1	2	2
U S Air	F100	U S A	1990	1	0	0	0	0	1	1	1	2	2
United	B727 stretch	U S A	1988	0	0	0	0	1	1	1	1	3	0
United	B727-200	U S A	1991	0	1	0	0	0	1	1	1	3	0
United	B737	U S A	1983	0	0	0	0	1	1	1	1	3	0
United	DC-10	U S A	1986	0	0	0	0	1	1	1	1	0	0

Note. Explanation of Coding

- Year: N/A Unknown
- Design Features: 0 Not Used 1 Used on Card
- Over-wing Exit Door: 0 Not Mentioned 1 On Seats in Front 2 Outside 3 On Seats in Exit Row 4 On Seats Behind
- Shoes: 0 Not Mentioned 1 Remove All Shoes 2 Remove High-Heels Shoes

APPENDIX D
ENGLISH TEST/QUESTIONNAIRE
(SIZE REDUCED TO 85% OF ORIGINAL)

QUESTION 2:

If you were asked to design a passenger safety information briefing card, which three features would you put the most emphasis on ?

Using the numbers 1, 2, and 3, with 1 indicating the most important item, please select the three features that would be most important to you.

- a) Drawings _____
- b) Photographs _____
- c) Durability of the card _____
- d) Use of different languages _____
- e) Multi-colored _____
- f) Size of the card _____
- g) Words/Writing _____

QUESTION 3:

On this and the following pages, you will find graphics which are similar to those used on actual passenger safety information briefing cards.

For each of the symbols presented, please describe in a few words what you think they represent most likely.

Example:



Do not smoke cigars or pipes

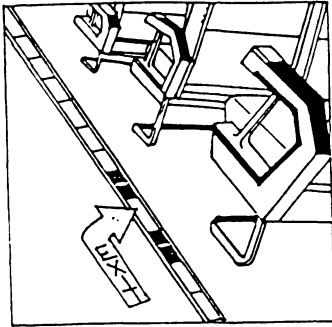

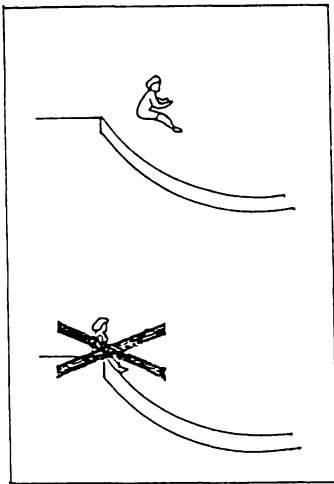

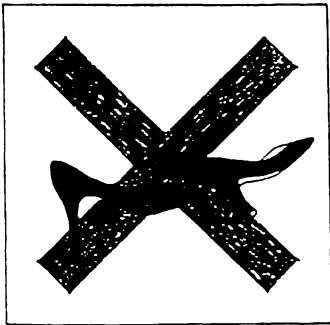

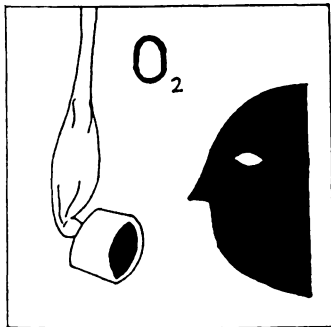

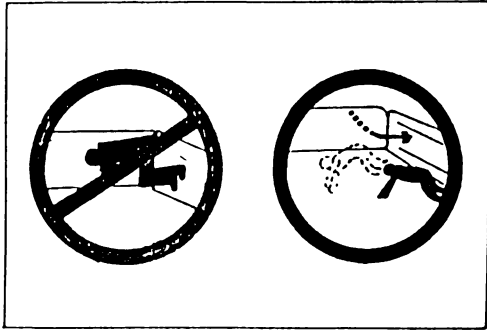
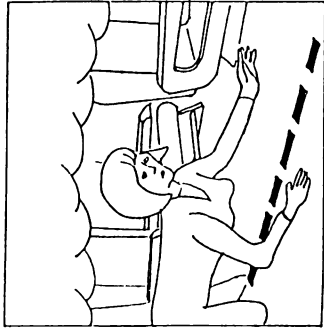
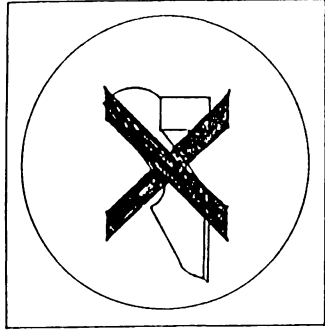
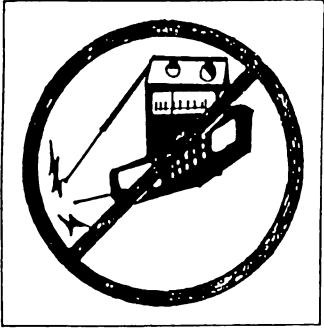

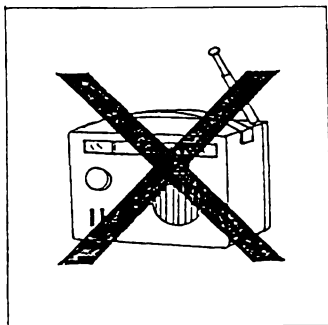
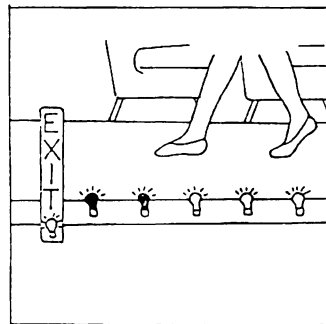
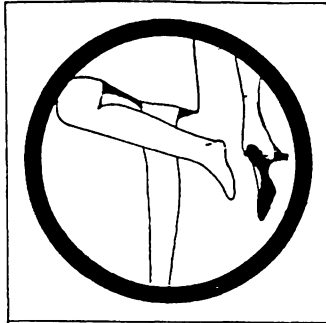
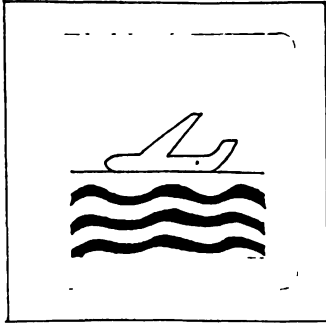

QUESTION 4

Let us assume you had to open an emergency exit during an aircraft evacuation, as indicated to the right.

WHERE WOULD YOU LEAVE THE DOOR ONCE REMOVED FROM THE FRAME ?

WOULD YOU PUT IT:

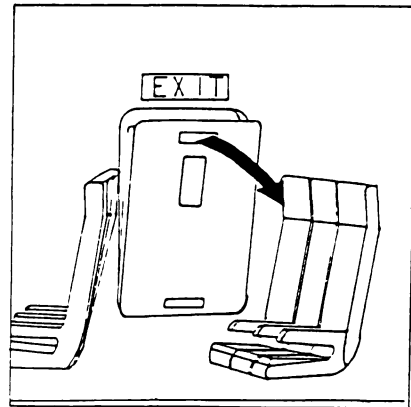

- a) on the seat in front of you, as in illustration
- b) throw it outside the plane, as in illustration
- c) on the seats in your row, as in illustration
- d) on the seats in the row behind you, as in illustration

- A _____
- B _____
- C _____
- D _____

A

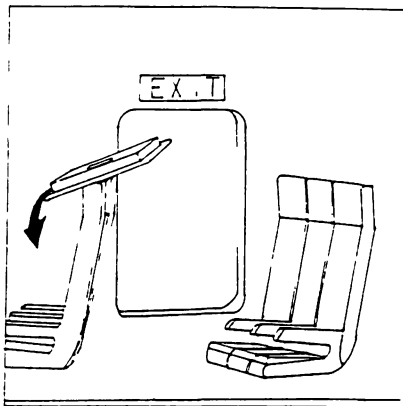

B

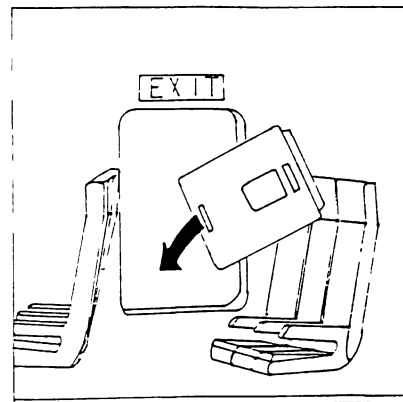

C

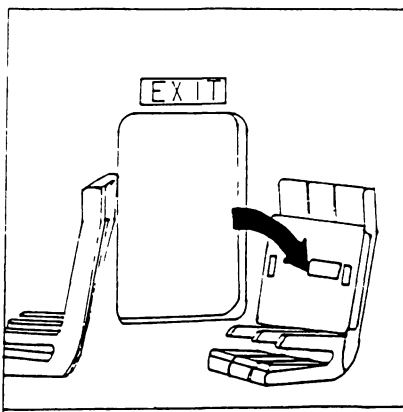

D

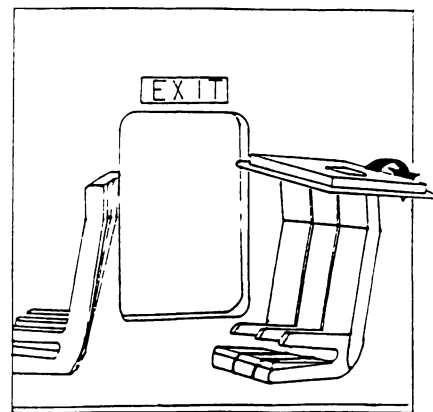

QUESTION 5:

Lights on the floor along the aisle provide guidance to exits.

5 a) What color most likely indicates an exit ?

white ____ yellow ____ red ____ green ____ blue ____

5 b) In your opinion, what color should be used to mark an exit ?

white ____ yellow ____ red ____ green ____ blue ____

QUESTION 6:

6 a) You are female ____ male ____

6 b) Your age is under 30 ____ 30 to 60 ____ over 60 ____

6 c) Your native language is _____

6 d) Your home country is _____

6 e) You are now studying in (country) _____

6 f) Your major is _____

APPENDIX E
TEST/QUESTIONNAIRE: FRENCH VERSION
(SIZE REDUCED TO 85% OF ORIGINAL)

QUESTION NO. 2:

Si l'on vous demandait de concevoir une carte de sécurité passager, sur quelles trois caractéristiques mettriez-vous le plus l'accent ?

Veillez indiquer les trois plus importantes caractéristiques par 1, 2 et 3 (1 représentant la plus importante).

- a) Dessins/Symbol/Graphique _____
- b) Photos _____
- c) Durabilité de la carte _____
- d) Différentes langues _____
- e) Différentes couleurs _____
- f) Dimensions de la carte _____
- g) Mots/Rédaction _____

QUESTION NO. 3:

Sur cette page et les suivantes, vous trouverez des graphiques similaires à ceux que l'on peut trouver sur de réelles cartes de sécurité passager.

Pour chacun des symboles suivants, veuillez décrire, en quelque mots, quelle est, pour vous, leur signification.

Example:



Interdiction de fumer le cigar ou
la pipe.

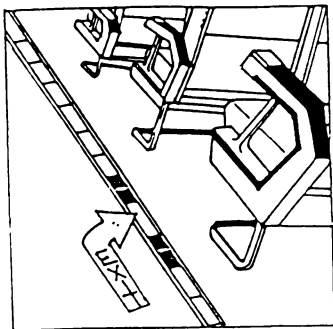

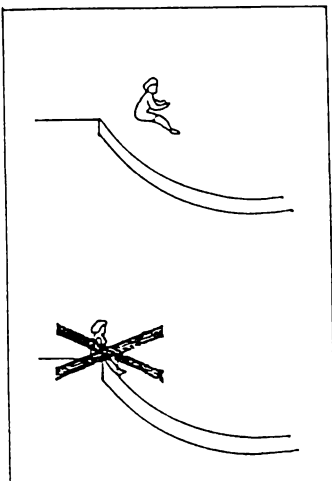

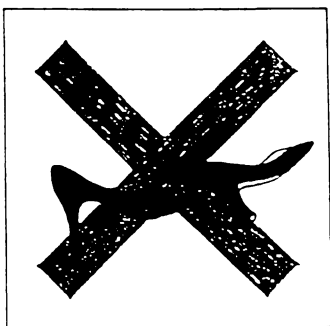

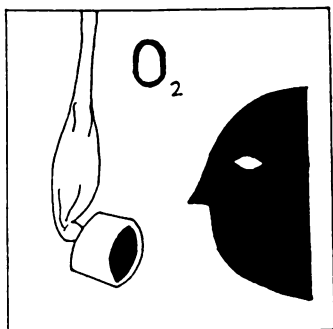



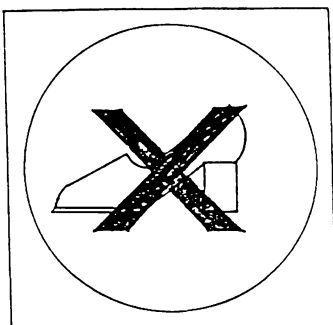

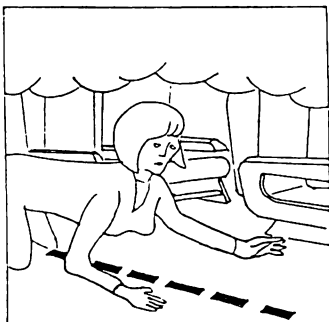

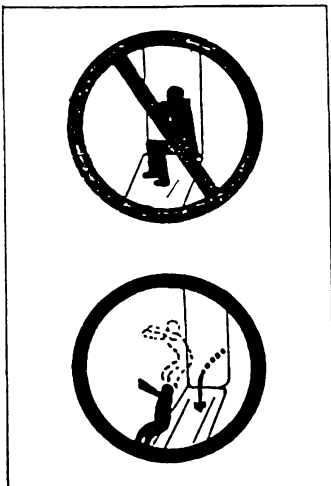

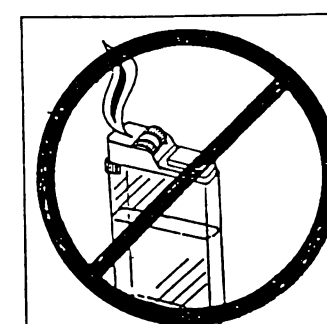
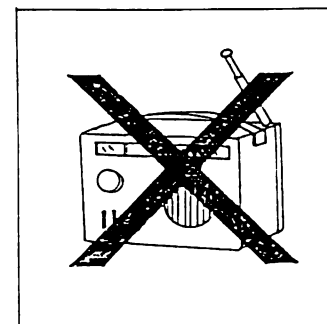
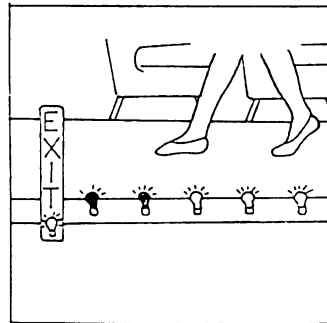
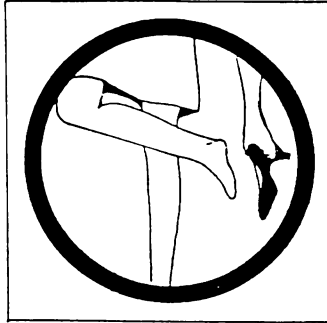
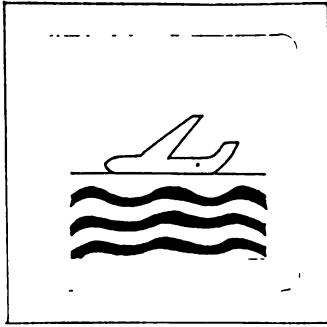

QUESTION NO. 4:

Imaginons que vous deviez ouvrir une issue de secours sur le coté droit lors de l'évacuation d'un avion,

QU'ALLEZ VOUS FAIRE DE LA PORTE ?

ALLEZ-VOUS LA

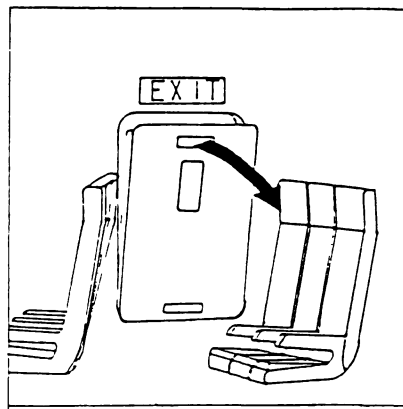

- a) mettre sur le siège devant vous, comme indiqué par la figure A _____
- b) jeter à l'extérieure, comme indiqué par la figure B _____
- c) mettre sur le siège à côté de vous, comme indiqué par la figure C _____
- d) mettre sur le siège derrière vous, comme indiqué par la figure D _____

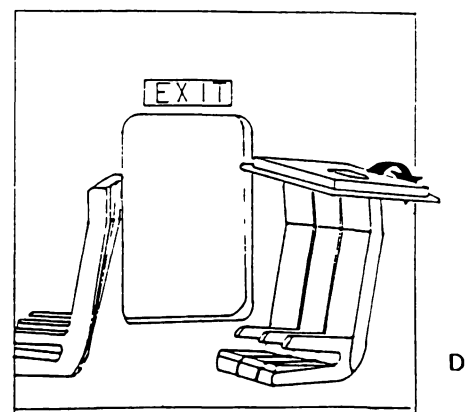
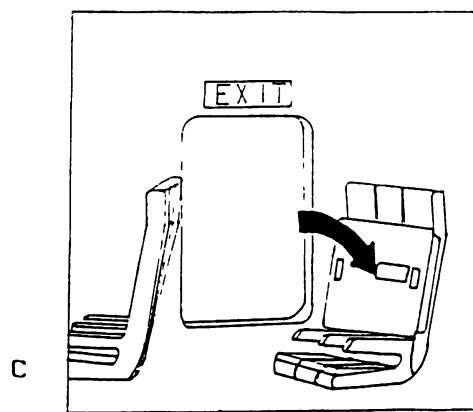
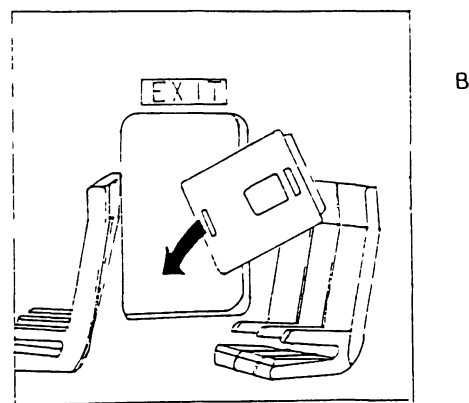
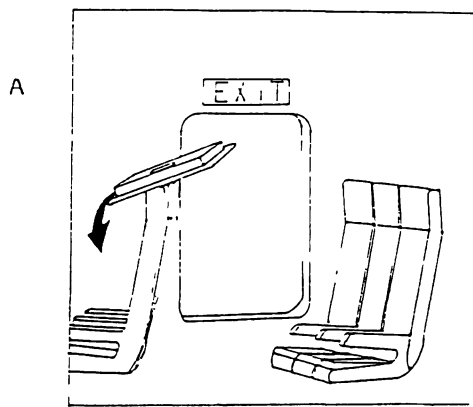

QUESTION NO. 5:

Le "sentier" lumineux le long des allées a pour but d'indiquer les issues de secours.

5 a) Quelle est la couleur qui vraisemblablement indique une issue de secours ?

blanc _____ jaune _____ rouge _____ vert _____ bleu _____

5 b) A votre avis, quelle couleur devrait être utilisée pour indiquer une issue de secours ?

blanc _____ jaune _____ rouge _____ vert _____ bleu _____

QUESTION NO. 6:

6 a) sexe féminin _____ masculin _____

6 b) age moins de 30 ans _____ de 30 à 60 ans _____ plus de 60 ans _____

6 c) Quelle est votre langue maternelle _____

6 d) Quel est votre pays d'origine _____

6 e) Dans quel pays effectuez-vous vos études _____

6 f) Dans quelle spécialité _____

APPENDIX F
TEST/QUESTIONNAIRE: GERMAN VERSION
(SIZE REDUCED TO 85% OF ORIGINAL)

FRAGE 2:

Wenn Sie gebeten würden, eine Sicherheits-Informationen-Karte für Flugpassagiere zu entwerfen, welche drei Charakteristika würden Sie für besonders wichtig halten ?

Bitte markieren Sie die drei wichtigsten Eigenschaften mit den Ziffern 1, 2 und 3, wobei 1 das wichtigste Charakteristikum angibt.

- a) Zeichnungen/Piktogramme _____
- b) Photos _____
- c) Haltbarkeit/Langlebigkeit der Karte _____
- d) Benutzung mehrerer Sprachen _____
- e) Mehrfarbig _____
- f) Größe der Karte _____
- g) Worte/Schrift _____

FRAGE 3:

Auf dieser und den folgenden Seiten finden Sie Symbole, die solchen auf heutigen Sicherheitskarten für Flugpassagiere ähneln.

Für jedes der abgebildeten Symbole, beschreiben Sie bitte in wenigen Worten, was nach Ihrer Meinung die wahrscheinlichste Bedeutung der Zeichnungen ist.

Beispiel:

Das Rauchen von Zigarren und
Pfeifen ist nicht gestattet.

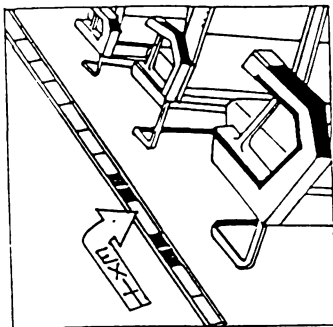

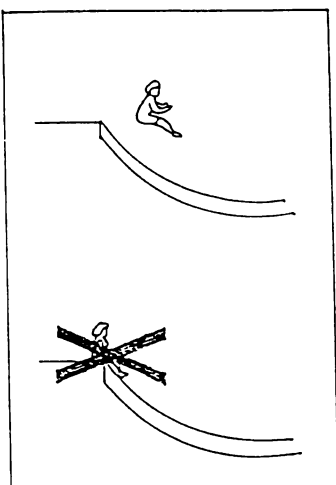

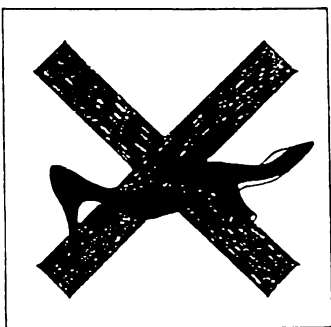

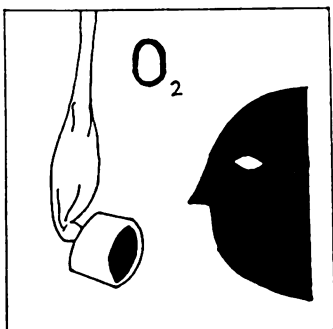

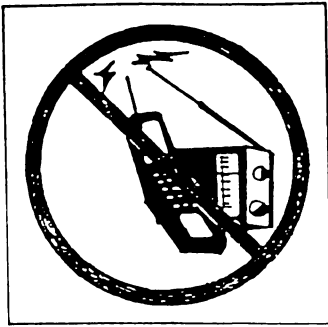

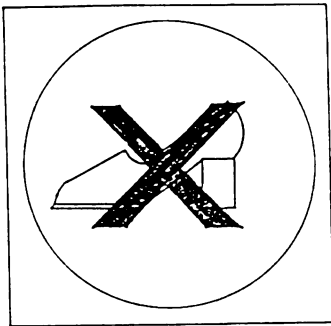

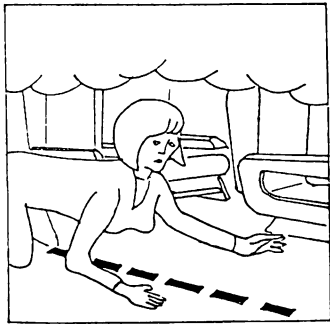

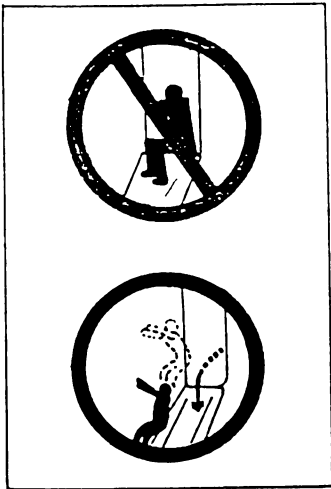

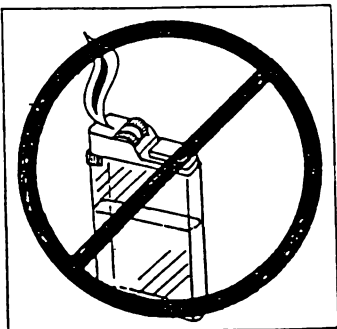
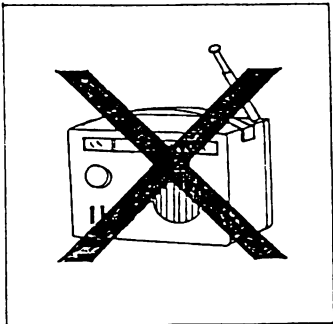
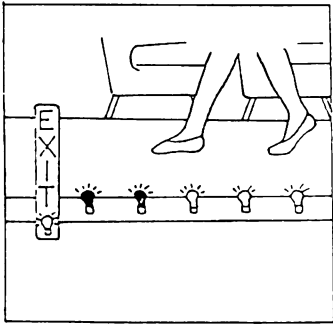
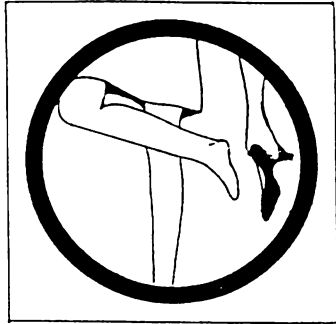
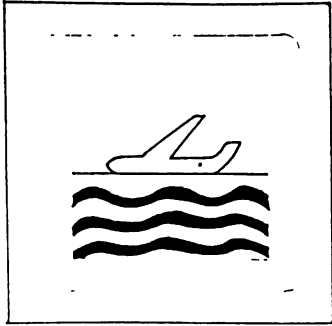

FRAGE 4:

Angenommen, Sie müßten während einer Flugzeug-Evakuierung einen Notausgang öffnen, so wie rechts dargestellt.

WO WÜRDEN SIE DIE TÜR DES NOTAUSGANGS LASSEN, NACHDEM SIE SIE AUS DEM RAHMEN GEHOBBEN HABEN ?

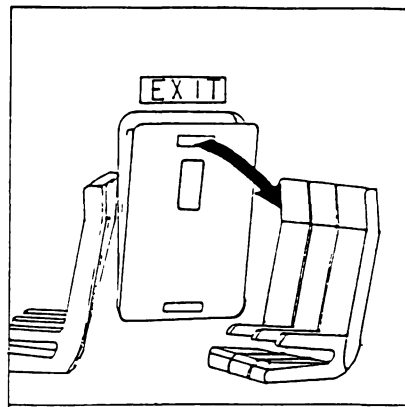

- a) auf die Sitze vor Ihnen, so wie in Abbildung
 b) aus dem Flugzeug, so wie in Abbildung
 c) auf die Sitze in Ihrer Sitzreihe, so wie in Abbildung
 d) auf die Sitze der Reihe hinter Ihnen, wie in Abbildung

A _____

B _____

C _____

D _____

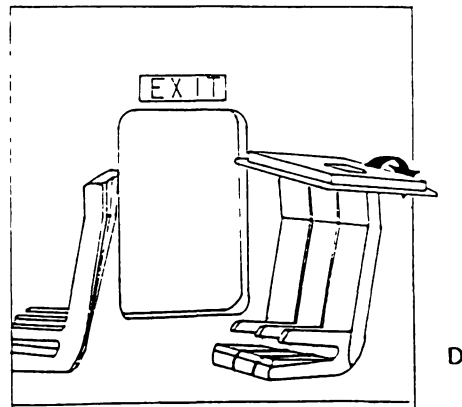
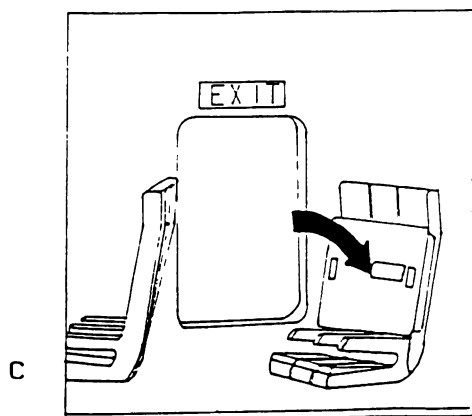
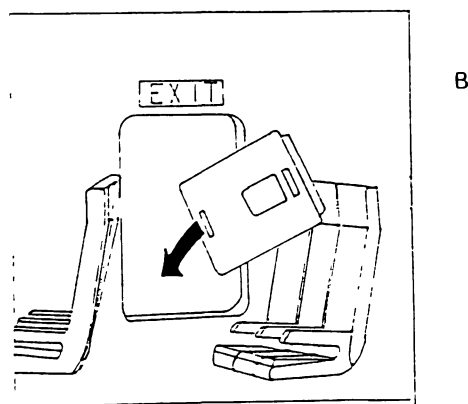
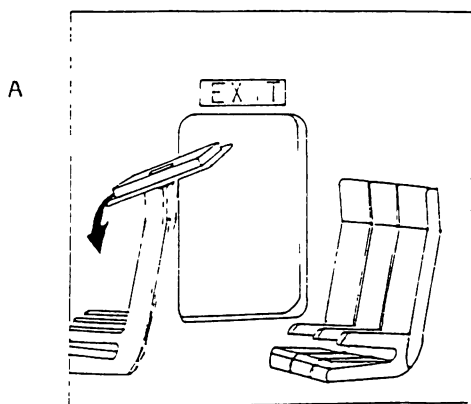

FRAGE 5:

Leuchten am Boden im Mittelgang führen zu den Notausgängen.

5 a) Welche Farbe zeigt am wahrscheinlichsten einen Notausgang an ?

weiß _____ gelb _____ rot _____ grün _____ blau _____

5 b) Nach Ihrer Meinung, welche Farbe sollte benutzt werden, um einen Ausgang zu markieren ?

weiß _____ gelb _____ rot _____ grün _____ blau _____

FRAGE 6:

6 a) Sie sind weiblich _____ männlich _____

6 b) Sie sind unter 30 _____ 30 bis 60 _____ über 60 _____ Jahre alt

6 c) Ihre Muttersprache ist _____

6 d) Ihr Heimatland ist _____

6 e) Sie studieren zur Zeit in (Land) _____

6 f) Ihr Studienfach ist _____

APPENDIX G
FAR PART 91.21

§ 91.21 Portable electronic devices.

(a) Except as provided in paragraph (b) of this section, no person may operate, nor may any operator or pilot in command of an aircraft allow the operation of, any portable electronic device on any of the following U.S.-registered civil aircraft:

(1) Aircraft operated by a holder of an air carrier operating certificate or an operating certificate; or

(2) Any other aircraft while it is operated under IFR.

(b) Paragraph (a) of this section does not apply to—

(1) Portable voice recorders;

(2) Hearing aids;

(3) Heart pacemakers;

(4) Electric shavers; or

(5) Any other portable electronic device that the operator of the aircraft has determined will not cause interference with the navigation or communication system of the aircraft on which it is to be used.

(c) In the case of an aircraft operated by a holder of an air carrier operating certificate or an operating certificate, the determination required by paragraph (b)(5) of this section shall be made by that operator of the aircraft on which the particular device is to be used. In the case of other aircraft, the determination may be made by the pilot in command or other operator of the aircraft.

APPENDIX H
PICTOGRAMS AND THEIR SOURCES

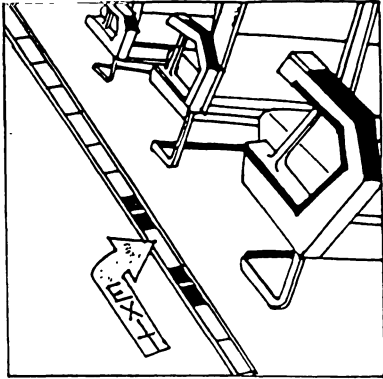

Pictogram 1 (EXIT1):

U.S. Air B-737-200/300

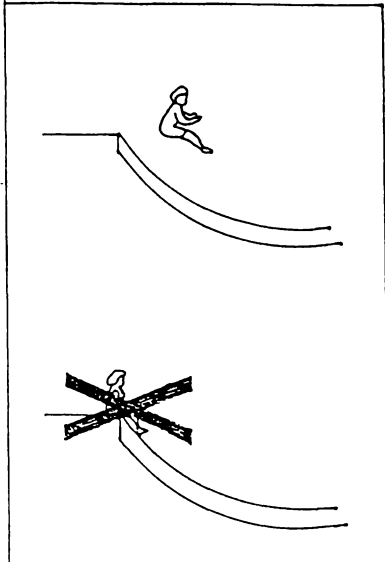

Pictogram 2 (SLIDE1):

Continental DC-9-30

Continental DC-9-80

Continental B737-200/300

Continental B727-100/200

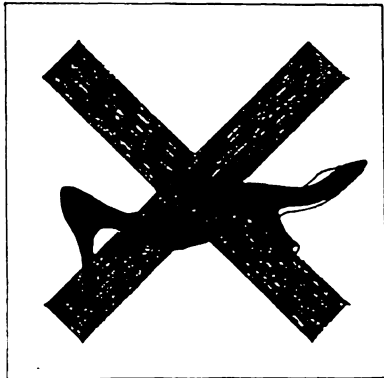

Pictogram 3 (HEELS1):

Euroberlin France B737

Cathay Pacific B747-300

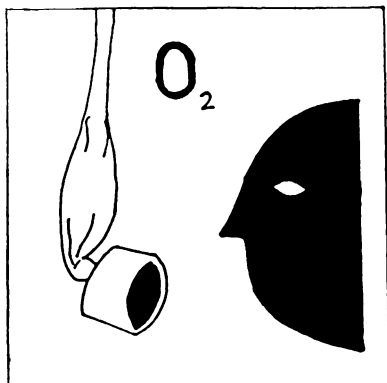

Pictogram 4 (OXYGEN):

United Airlines B-727-200 (new)

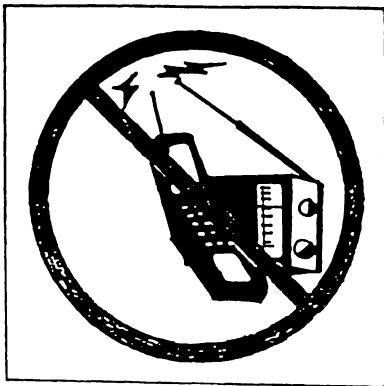

Pictogram 5 (ELECTRO1):

PAN AM B727

PAN AM A310

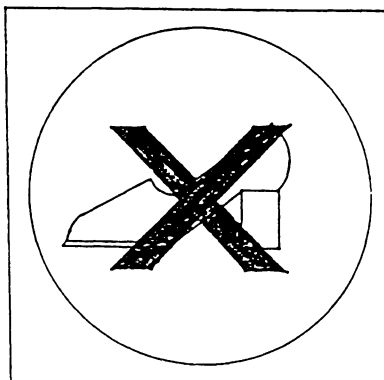

Pictogram 6 (HEELS2):

LUXAIR B737-200

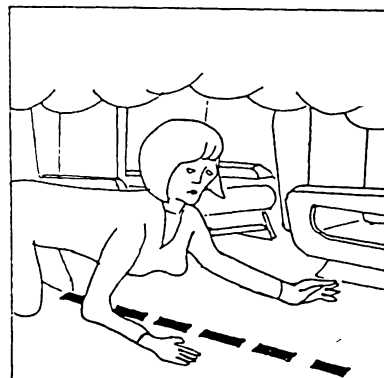

Pictogram 7 (SMOKELIG):

Lufthansa (all cards)

Hapag-Lloyd A310

LTU MD-11

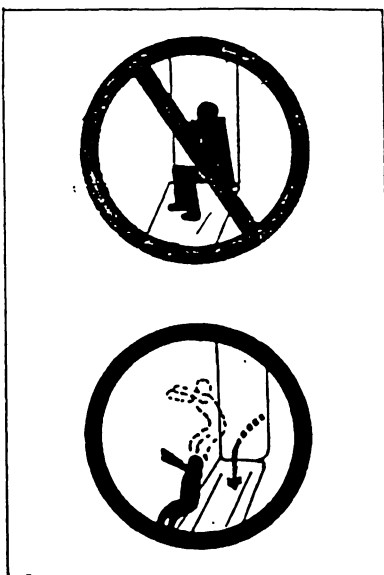

Pictogram 8 (SLIDE2):

United Airlines B727-200

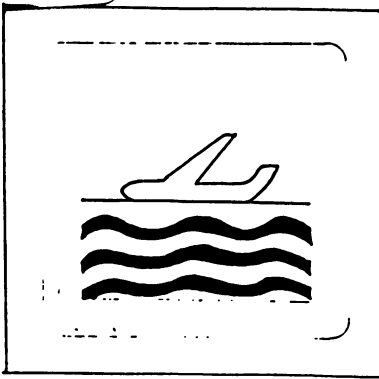
**Pictogram 9 (DITCH);**

Lufthansa (all cards)

Eastern Airlines B727-200

Eastern Airlines DC-9-31/51

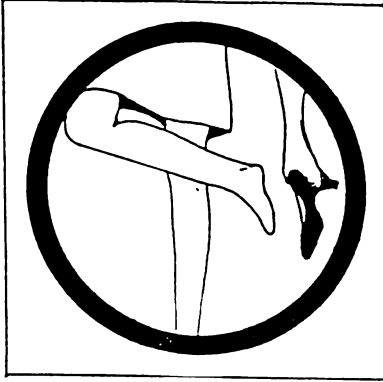
**Pictogram 10 (HEELS3)**

Garuda Indonesia A300

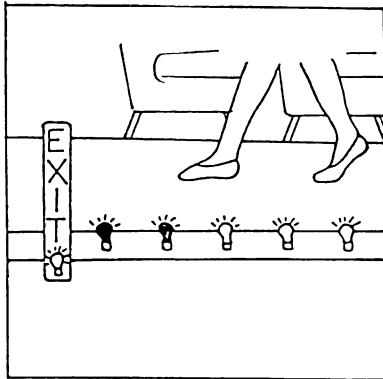
**Pictogram 11 (FLOORLIG):**

Continental Airlines (all cards)

Singapore Airlines A310/B747-400

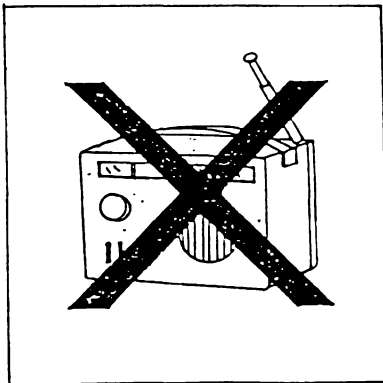
**Pictogram 12 (ELECTRO2):**

Continental Airlines (numerous cards)

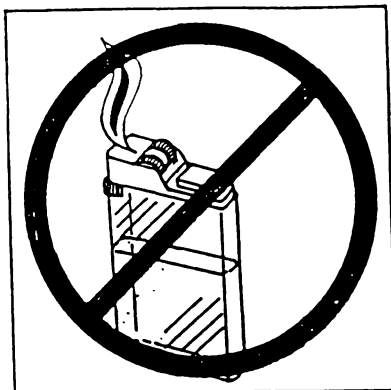
**Pictogram 13 (BUTANE):**

U.S. Air B737-200/300

U.S. Air F100

APPENDIX I
TEST INSTRUCTIONS IN ENGLISH, FRENCH, GERMAN
(SIZE REDUCED TO 85% OF ORIGINAL)

Instructions for Test Supervisors

Thank you for allocating your time to participate in this study.

Instructions:

1. Please hand out the test to the students. Please assure that every student receives his/her own copy.
2. Please read the following instructions to the students:
This test is part of a study for a Master's Thesis in aviation. The test in front of you is given to students in several countries worldwide. Thank you for your participation and cooperation. Your answers to the test will be anonymous. Therefore, please do not sign your name anywhere on the test. You have 15 minutes to complete the test which should be ample. I will inform you after 10 minutes that 5 minutes are left to finish the test. Please read each question carefully, and answer in such a way which best represents you and your opinions. Please give professional answers in order to make this study a success. Please answer the test in (your country's language, here: English). Thank you, please start now.
3. Start the time.
4. After 10 minutes, please read the following statement:
10 minutes are up, you have 5 more minutes to complete the test. Please try to answer all questions. Please make sure that you answer question 6.
5. When 15 minutes from start have passed, please read the following:
15 minutes are up, please stop answering. Turn to the last page of the test and make sure that you have answered question 6. If you have not yet answered question 6, please do so now.
6. Please collect all answer sheets.
Put the tests in and seal the enclosed return envelope.
7. Send the tests to the following address (as on the return envelopes):

Dr. John Wise / Florian Jentsch
Center for Aviation/Aerospace Research (CAAR)
Embry-Riddle Aeronautical University
Daytona Beach, Florida 32114
U.S.A.

Please use air mail and indicate "documents" on the letter for customs purposes.

Again, thank you very much for your help.

Instruction pour le surveillant

Merci de prendre le temps de participer à cette étude.

Instructions:

1. Veuillez distribuer le test. Assurez-vous que chaque étudiant reçoive un exemplaire.
2. Veuillez lire les instructions suivantes aux étudiants:
Ce test rentre dans le cadre d'une thèse de Master en aviation. Le questionnaire que vous avez devant vous a été traduit en différentes langues et va être complété par des étudiants de différents pays. Merci pour votre participation. Les réponses à ce test sont anonymes. Vous êtes donc priés de ne pas mentionner votre nom. Vous avez 15 minutes pour compléter ce questionnaire, ce qui devrait être amplement suffisant. Je vous avertirai quand il ne restera plus que 5 minutes. Veuillez lire attentivement chaque question, et répondre de telle manière à ce que vos réponses reflètent le plus précisément votre opinion. Soyez le plus professionnel que possible afin d'assurer le succès de cette étude. Répondez à ce test en français. Merci. Vous pouvez commencer maintenant.
3. Commencer le chronométrage.
4. Après 10 minutes, veuillez lire aux étudiants ce qui suit:
Il vous reste 5 minutes. Essayer de répondre à toutes les questions. Assurez-vous que vous avez répondu à la question no. 6.
5. Une fois les 15 minutes écoulées veuillez lire ce qui suit:
Les 15 minutes sont passées, veuillez arrêter d'écrire. Vérifiez que vous avez bien répondu à la question no. 6 à la dernière page du questionnaire. Si vous n'avez pas complété cette question, veuillez le faire maintenant.
6. Veuillez ramasser les questionnaires.
 Veuillez mettre les tests dans l'enveloppe et la fermer.
7. Veuillez envoyer cette enveloppe à l'adresse suivante:

Dr. John Wise / Florian Jentsch
 Center for Aviation/Aerospace Research (CAAR)
 Embry-Riddle Aeronautical University
 Daytona Beach, Florida 32114
 U.S.A.

Assurez-vous que ce courrier est envoyé "par avion" et indiquez "documents" sur l'enveloppe pour faciliter le passage de la douane.
 Une fois encore, mes sincères remerciements pour votre aide.

Instruktionen für den Test

Vielen Dank für die Zeit und Muhe, die Sie diesem Projekt widmen.

Instruktionen:

1. Bitte verteilen Sie den Test an die Studenten. Bitte stellen Sie sicher, daß jeder Student/jede Studentin je eigene Fragebogen erhält.
2. Bitte lesen Sie den Studenten die folgenden Instruktionen vor:
Dieser Test ist Teil einer Diplomarbeit in Luft- und Raumfahrttechnik. Der Test vor Ihnen wird Studenten in mehreren Ländern weltweit gegeben. Vielen Dank für Ihre Teilnahme und Kooperation. Ihre Antworten zu diesem Test sind anonym. Schreiben Sie daher nicht Ihren Namen auf die Fragebögen. Sie haben 15 Minuten, um den Test zu beantworten, was mehr als genug Zeit sein sollte. Nach 10 Minuten werde ich Sie darauf hinweisen, daß fünf Minuten verbleiben, um den Test zu vervollständigen. Bitte lesen Sie alle Fragen aufmerksam, und antworten Sie so, daß Sie und Ihre Meinungen am besten wiedergegeben sind. Bitte geben Sie professionelle Antworten, um diese Studie zu einem Erfolg zu machen. Bitte antworten Sie in Deutsch. Vielen Dank, beginnen Sie jetzt.
3. Starten Sie die Zeit.
4. Bitte lesen Sie die folgenden Satze, nachdem 10 Minuten um sind:
10 Minuten sind um, 5 Minuten verbleiben, um den Test zu beenden. Bitte versuchen Sie, alle Fragen zu beantworten. Bitte stellen Sie sicher, daß Sie Frage 6 beantworten.
5. 15 Minuten nach Beginn, verlesen Sie bitte das Folgende:
15 Minuten sind um, bitte beenden Sie den Test. Schlagen Sie die letzte Seite des Tests auf, und überprüfen Sie, ob Sie Frage 6 beantwortet haben. Wenn Sie Frage 6 noch nicht beantwortet haben, tun Sie das bitte jetzt.
6. Bitte sammeln Sie alle Fragebogen ein.
 Tun Sie die Tests in den beigelegten Ruckumschlag und schließen Sie ihn.
7. Senden Sie den Test an die folgende Adresse (wie auf dem Ruckumschlag):

Dr. John Wise / Florian Jentsch
Center for Aviation/Aerospace Research (CAAR)
Embry-Riddle Aeronautical University
Daytona Beach, Florida 32114
U.S.A.

Bitte benutzen Sie Luftpost und schreiben Sie "Dokumente" in die Zollerklärung.
 Nochmals, vielen Dank für Ihre Hilfe.

APPENDIX J
TEST RESULTS FOR THE 13 PICTOGRAMS

TABLE OF EXIT1 (ROWS) BY LANGUAGE\$ (COLUMNS)

FREQUENCIES

	BRITISH	FRENCH	GERMAN	US	TOTAL
-1.0000	3	14	1	3	21
0.0000	12	16	35	24	87
1.0000	12	7	13	10	42
TOTAL	27	37	49	37	150

TABLE OF EXIT1 (ROWS) BY LANGUAGE\$ (COLUMNS)

COLUMN PERCENTS

	BRITISH	FRENCH	GERMAN	US	TOTAL	N
-1.0000	11.11	37.84	2.04	8.11	14.00	21.00
0.0000	44.44	43.24	71.43	64.86	58.00	87.00
1.0000	44.44	18.92	26.53	27.03	28.00	42.00
TOTAL	100.00	100.00	100.00	100.00	100.00	
N	27	37	49	37	150	

TABLE OF SLIDE1 (ROWS) BY LANGUAGE\$ (COLUMNS)

FREQUENCIES

	BRITISH	FRENCH	GERMAN	US	TOTAL
-1.0000	0	0	3	3	6
0.0000	1	2	12	4	19
1.0000	26	35	34	30	125
TOTAL	27	37	49	37	150

TABLE OF SLIDE1 (ROWS) BY LANGUAGE\$ (COLUMNS)

COLUMN PERCENTS

	BRITISH	FRENCH	GERMAN	US	TOTAL	N
-1.0000	.00	.00	6.12	8.11	4.00	6.00
0.0000	3.70	5.41	24.49	10.81	12.67	19.00
1.0000	96.30	94.59	69.39	81.08	83.33	125.00
TOTAL	100.00	100.00	100.00	100.00	100.00	
N	27	37	49	37	150	

TABLE OF HEELS1 (ROWS) BY LANGUAGE\$ (COLUMNS)

FREQUENCIES

	BRITISH	FRENCH	GERMAN	US	TOTAL
-1.0000	0	1	4	1	6
0.0000	3	10	6	3	22
1.0000	24	26	39	33	122
TOTAL	27	37	49	37	150

TABLE OF HEELS1 (ROWS) BY LANGUAGE\$ (COLUMNS)

COLUMN PERCENTS

	BRITISH	FRENCH	GERMAN	US	TOTAL	N
-1.0000	.00	2.70	8.16	2.70	4.00	6.00
0.0000	11.11	27.03	12.24	8.11	14.67	22.00
1.0000	88.89	70.27	79.59	89.19	81.33	122.00
TOTAL	100.00	100.00	100.00	100.00	100.00	
N	27	37	49	37	150	

TABLE OF OXYGEN (ROWS) BY LANGUAGE\$ (COLUMNS)

FREQUENCIES

	BRITISH	FRENCH	GERMAN	US	TOTAL
-1.0000	1	1	2	2	6
0.0000	1	1	1	1	4
1.0000	25	35	46	34	140
TOTAL	27	37	49	37	150

TABLE OF OXYGEN (ROWS) BY LANGUAGE\$ (COLUMNS)

COLUMN PERCENTS

	BRITISH	FRENCH	GERMAN	US	TOTAL	N
-1.0000	3.70	2.70	4.08	5.41	4.00	6.00
0.0000	3.70	2.70	2.04	2.70	2.67	4.00
1.0000	92.59	94.59	93.88	91.89	93.33	140.00
TOTAL	100.00	100.00	100.00	100.00	100.00	
N	27	37	49	37	150	

TABLE OF ELECTRO1 (ROWS) BY LANGUAGE\$ (COLUMNS)
FREQUENCIES

	BRITISH	FRENCH	GERMAN	US	TOTAL
-1.0000	0	0	1	1	2
0.0000	17	12	15	28	72
1.0000	10	25	33	8	76
TOTAL	27	37	49	37	150

TABLE OF ELECTRO1 (ROWS) BY LANGUAGE\$ (COLUMNS)

COLUMN PERCENTS

	BRITISH	FRENCH	GERMAN	US	TOTAL	N
-1.0000	.00	.00	2.04	2.70	1.33	2.00
0.0000	62.96	32.43	30.61	75.68	48.00	72.00
1.0000	37.04	67.57	67.35	21.62	50.67	76.00
TOTAL	100.00	100.00	100.00	100.00	100.00	
N	27	37	49	37	150	

TABLE OF HEELS2 (ROWS) BY LANGUAGE\$ (COLUMNS)

FREQUENCIES

	BRITISH	FRENCH	GERMAN	US	TOTAL
-1.0000	5	1	1	2	9
0.0000	6	8	11	7	32
1.0000	16	28	37	28	109
TOTAL	27	37	49	37	150

TABLE OF HEELS2 (ROWS) BY LANGUAGE\$ (COLUMNS)

COLUMN PERCENTS

	BRITISH	FRENCH	GERMAN	US	TOTAL	N
-1.0000	18.52	2.70	2.04	5.41	6.00	9.00
0.0000	22.22	21.62	22.45	18.92	21.33	32.00
1.0000	59.26	75.68	75.51	75.68	72.67	109.00
TOTAL	100.00	100.00	100.00	100.00	100.00	
N	27	37	49	37	150	

TABLE OF SMOKEIG (ROWS) BY LANGUAGE\$ (COLUMNS)
FREQUENCIES

	BRITISH	FRENCH	GERMAN	US	TOTAL
-1.0000	0	6	10	3	19
0.0000	13	18	15	26	72
1.0000	14	13	24	8	59
TOTAL	27	37	49	37	150

TABLE OF SMOKEIG (ROWS) BY LANGUAGE\$ (COLUMNS)
COLUMN PERCENTS

	BRITISH	FRENCH	GERMAN	US	TOTAL	N
-1.0000	.00	16.22	20.41	8.11	12.67	19.00
0.0000	48.15	48.65	30.61	70.27	48.00	72.00
1.0000	51.85	35.14	48.98	21.62	39.33	59.00
TOTAL	100.00	100.00	100.00	100.00	100.00	
N	27	37	49	37	150	

TABLE OF SLIDE2 (ROWS) BY LANGUAGE\$ (COLUMNS)
FREQUENCIES

	BRITISH	FRENCH	GERMAN	US	TOTAL
-1.0000	0	3	2	4	9
0.0000	2	8	8	4	22
1.0000	25	26	39	29	119
TOTAL	27	37	49	37	150

TABLE OF SLIDE2 (ROWS) BY LANGUAGE\$ (COLUMNS)
COLUMN PERCENTS

	BRITISH	FRENCH	GERMAN	US	TOTAL	N
-1.0000	.00	8.11	4.08	10.81	6.00	9.00
0.0000	7.41	21.62	16.33	10.81	14.67	22.00
1.0000	92.59	70.27	79.59	78.38	79.33	119.00
TOTAL	100.00	100.00	100.00	100.00	100.00	
N	27	37	49	37	150	

TABLE OF DITCH (ROWS) BY LANGUAGE\$ (COLUMNS)
FREQUENCIES

	BRITISH	FRENCH	GERMAN	US	TOTAL
-1.0000	9	19	19	22	69
0.0000	14	14	23	11	62
1.0000	4	4	7	4	19
TOTAL	27	37	49	37	150

TABLE OF DITCH (ROWS) BY LANGUAGE\$ (COLUMNS)
COLUMN PERCENTS

	BRITISH	FRENCH	GERMAN	US	TOTAL	N
-1.0000	33.33	51.35	38.78	59.46	46.00	69.00
0.0000	51.85	37.84	46.94	29.73	41.33	62.00
1.0000	14.81	10.81	14.29	10.81	12.67	19.00
TOTAL	100.00	100.00	100.00	100.00	100.00	
N	27	37	49	37	150	

TABLE OF HEELS3 (ROWS) BY LANGUAGE\$ (COLUMNS)
FREQUENCIES

	BRITISH	FRENCH	GERMAN	US	TOTAL
-1.0000	7	6	5	10	28
0.0000	12	20	20	19	71
1.0000	8	11	24	8	51
TOTAL	27	37	49	37	150

TABLE OF HEELS3 (ROWS) BY LANGUAGE\$ (COLUMNS)
COLUMN PERCENTS

	BRITISH	FRENCH	GERMAN	US	TOTAL	N
-1.0000	25.93	16.22	10.20	27.03	18.67	28.00
0.0000	44.44	54.05	40.82	51.35	47.33	71.00
1.0000	29.63	29.73	48.98	21.62	34.00	51.00
TOTAL	100.00	100.00	100.00	100.00	100.00	
N	27	37	49	37	150	

TABLE OF FLOORLIG (ROWS) BY LANGUAGE\$ (COLUMNS)

FREQUENCIES

	BRITISH	FRENCH	GERMAN	US	TOTAL
-1.0000	3	8	4	2	17
0.0000	3	9	12	10	34
1.0000	21	20	33	25	99
TOTAL	27	37	49	37	150

TABLE OF FLOORLIG (ROWS) BY LANGUAGE\$ (COLUMNS)

COLUMN PERCENTS

	BRITISH	FRENCH	GERMAN	US	TOTAL	N
-1.0000	11.11	21.62	8.16	5.41	11.33	17.00
0.0000	11.11	24.32	24.49	27.03	22.67	34.00
1.0000	77.78	54.05	67.35	67.57	66.00	99.00
TOTAL	100.00	100.00	100.00	100.00	100.00	
N	27	37	49	37	150	

TABLE OF ELECTRO2 (ROWS) BY LANGUAGE\$ (COLUMNS)

FREQUENCIES

	BRITISH	FRENCH	GERMAN	US	TOTAL
-1.0000	0	0	2	0	2
0.0000	20	29	27	35	111
1.0000	7	8	20	2	37
TOTAL	27	37	49	37	150

TABLE OF ELECTRO2 (ROWS) BY LANGUAGE\$ (COLUMNS)

COLUMN PERCENTS

	BRITISH	FRENCH	GERMAN	US	TOTAL	N
-1.0000	.00	.00	4.08	.00	1.33	2.00
0.0000	74.07	78.38	55.10	94.59	74.00	111.00
1.0000	25.93	21.62	40.82	5.41	24.67	37.00
TOTAL	100.00	100.00	100.00	100.00	100.00	
N	27	37	49	37	150	

TABLE OF BUTANE (ROWS) BY LANGUAGE\$ (COLUMNS)

FREQUENCIES

	BRITISH	FRENCH	GERMAN	US	TOTAL
-1.0000	0	1	0	0	1
0.0000	24	36	44	34	138
1.0000	3	0	5	3	11
TOTAL	27	37	49	37	150

TABLE OF BUTANE (ROWS) BY LANGUAGE\$ (COLUMNS)

COLUMN PERCENTS

	BRITISH	FRENCH	GERMAN	US	TOTAL	N
-1.0000	.00	2.70	.00	.00	.67	1.00
0.0000	88.89	97.30	89.80	91.89	92.00	138.00
1.0000	11.11	.00	10.20	8.11	7.33	11.00
TOTAL	100.00	100.00	100.00	100.00	100.00	
N	27	37	49	37	150	