

12-2016

## Application of Floating Pedal Regenerative Braking for a Rear-Wheel-Drive Parallel-Series Plug-In Hybrid Electric Vehicle with an Automatic Transmission

Dylan Lewis Lewton

Follow this and additional works at: <https://commons.erau.edu/edt>



Part of the [Automotive Engineering Commons](#), and the [Electro-Mechanical Systems Commons](#)

---

### Scholarly Commons Citation

Lewton, Dylan Lewis, "Application of Floating Pedal Regenerative Braking for a Rear-Wheel-Drive Parallel-Series Plug-In Hybrid Electric Vehicle with an Automatic Transmission" (2016). *Dissertations and Theses*. 307.

<https://commons.erau.edu/edt/307>

This Thesis - Open Access is brought to you for free and open access by Scholarly Commons. It has been accepted for inclusion in Dissertations and Theses by an authorized administrator of Scholarly Commons. For more information, please contact [commons@erau.edu](mailto:commons@erau.edu).

APPLICATION OF FLOATING PEDAL REGENERATIVE BRAKING FOR A REAR-  
WHEEL-DRIVE PARALLEL-SERIES PLUG-IN HYBRID ELECTRIC VEHICLE  
WITH AN AUTOMATIC TRANSMISSION

by

Dylan Lewis Lewton

A Thesis Submitted to the College of Engineering Department of Mechanical  
Engineering in Partial Fulfillment of the Requirements for the Degree of  
Master of Science in Mechanical Engineering

Embry-Riddle Aeronautical University  
Daytona Beach, Florida  
December 2016

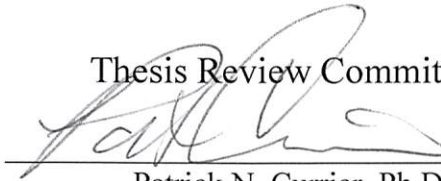
APPLICATION OF FLOATING PEDAL REGENERATIVE BRAKING FOR A REAR-  
WHEEL-DRIVE PARALLEL-SERIES PLUG-IN HYBRID ELECTRIC VEHICLE  
WITH AN AUTOMATIC TRANSMISSION

by

Dylan Lewis Lewton

This thesis was prepared under the direction of the candidate's Thesis Committee Chair, Dr. Patrick N. Currier, Professor, Daytona Beach Campus, and Thesis Committee Members Dr. Marc Compere, Professor, Daytona Beach Campus, and Dr. Darris L. White, Professor, Daytona Beach Campus, and has been approved by the Thesis Committee. It was submitted to the Department of Mechanical Engineering in partial fulfillment of the requirements for the degree of Master of Science in Mechanical Engineering

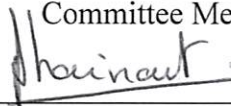
Thesis Review Committee:



Patrick N. Currier, Ph.D.  
Committee Chair



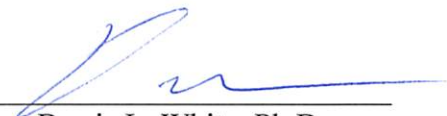
Marc Compere, Ph.D.  
Committee Member



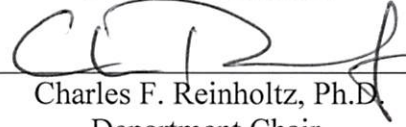
Jean-Michel Dhainaut, Ph.D.  
Graduate Program Chair,  
Mechanical Engineering



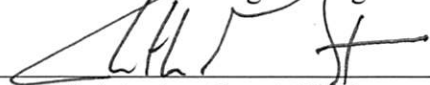
Maj Mirmirani, Ph.D.  
Dean, College of Engineering



Darris L. White, Ph.D.  
Committee Member



Charles F. Reinholtz, Ph.D.  
Department Chair,  
Mechanical Engineering



Christopher Grant, Ph.D.  
Associate Vice President of Academics

12/6/16  
Date

## Acknowledgements

First and foremost, I would like to thank my thesis advisor Dr. Currier for all his support and guidance throughout the completion of this thesis.

Although there were several people that helped with this thesis, I would like to give a special thanks to Adam Szechy, Matthew Nelson, Abdulla Karmustaji, and Marc Compere. Adam for working closely with me to develop a full vehicle model that could be used for testing control algorithms before vehicle testing. Matthew for helping find bugs in the regenerative brake controller and integrating it into car controller. Abdulla's thesis provided valuable insight on shift logic and his work on the powertrain model was extremely helpful. Marc Compere's Advanced Vehicle Dynamics class was extremely helpful in developing a seven-degree of freedom vehicle dynamics model.

## Abstract

Researcher: Dylan Lewis Lewton

Title: APPLICATION OF FLOATING PEDAL REGENERATIVE BRAKING FOR A REAR-WHEEL-DRIVE PARALLEL-SERIES PLUG-IN HYBRID ELECTRIC VEHICLE WITH AN AUTOMATIC TRANSMISSION

Institution: Embry-Riddle Aeronautical University

Degree: Master of Science in Mechanical Engineering

Year: 2016

As the world continues to move further away from our reliance on fossil fuels, hybrid vehicles are becoming ever more popular. Braking is a system on both hybrid and normal vehicles that involves a significant amount of power and energy. A hybrid can recapture some of that energy using regenerative braking. In this thesis, a method is devised to blend hydraulic and regenerative braking in the most effective manner. A MATLAB Simulink model was built to simulate a parallel-series plug-in hybrid electric vehicle. The model allows for the implementation of a regenerative brake controller that utilizes floating pedal regen, custom shift logic, and brake pedal blended regen. The floating pedal controller activates regenerative braking when the driver releases the accelerator pedal. This is done by remapping the pedal based on vehicle speed, gear position, and wheel torques. The custom shift logic utilizes the motor rpm and efficiencies curves to determine when to shift the transmission. The brake pedal regen is added to the hydraulic braking based on brake pedal position. This regenerative brake controller can recharge the battery by 2% SOC during one deceleration event from 130 kph to 20 kph, while maintaining a comfortable deceleration rate less than  $3\text{m/sec}^2$ .

## Table of Contents

Thesis Review Committee .....	i
Acknowledgements .....	ii
Abstract .....	iii
List of Figures .....	v
Limitations and Assumptions .....	vii
List of Acronyms .....	vii
Introduction .....	1
Significance of the Study .....	1
Statement of the Problem .....	2
Purpose Statement .....	3
Vehicle Architecture .....	3
Thesis Statement .....	5
Review of the Relevant Literature .....	6
Regenerative Braking .....	6
Vehicle Dynamics .....	14
Methodology .....	15
Vehicle Body Model .....	15
Powertrain Model .....	22
Regenerative Brake Controller .....	26
Model Validation .....	32
Vehicle Testing .....	32
Results .....	34
Comparative Analysis with and Without Shift Logic .....	38
Fusion Hydraulic and Regenerative Brake Pedal .....	42
Conclusions, and Future Work .....	45
Conclusions .....	45
Future Work .....	46
Appendix .....	48
Bibliography .....	48

## List of Figures

Figure 1: Manufacturers and total sales of electric vehicles [1] .....	1
Figure 2: Efficiency plot of electric motors [2] .....	2
Figure 3: Vehicle architecture for Embry-Riddle ESS Chevrolet Camaro.....	4
Figure 4: The left side of the figure shows the series mode configuration and the right shows the parallel mode configuration .....	5
Figure 5: Diagram of the vehicle forces [3].....	15
Figure 6: Rotational subsystem of vehicle dynamics model .....	16
Figure 7: Converting vehicle speed and angular wheel velocity to longitudinal and lateral wheel velocities.....	17
Figure 8: Longitudinal Weight transfer subsystem.....	18
Figure 9: Lateral weight transfer block.....	19
Figure 10: Calculation and summation of the lateral and longitudinal wheel forces .....	20
Figure 11: Calculation of vehicles velocities based off longitudinal and lateral velocities .....	21
Figure 12: Vehicle driving animation .....	22
Figure 13: Engine model.....	23
Figure 14: Lookup tables for the engine .....	23
Figure 15: Bosch IMG subsystem, which is made up of lookup tables.....	24
Figure 16: Block for friction clutches between motors .....	25
Figure 17: Transmission subsystem.....	25
Figure 18: Battery model .....	26
Figure 19: Regenerative braking subsystem .....	26
Figure 20: Floating pedal regenerative braking .....	27
Figure 21: Zero point subsystem to remap pedal.....	28
Figure 22: Dynamic lookup table to generate a floating zero pedal map .....	28
Figure 23: Overall regenerative brake controller.....	29
Figure 24: Custom shift logic regen.....	30
Figure 25: State flow of shift logic .....	31
Figure 26: Regen with brake pedal .....	31
Figure 27: 0-60 comparison for model validation .....	32
Figure 28: Accelerator pedal position during deceleration.....	34
Figure 29: Velocity comparison between model and testing during regenerative braking .....	35
Figure 30: Modeled current trace vs. current trace from testing.....	36

Figure 31: Comparison of modeled regen torque and regen torque from testing .....	36
Figure 32: Graph of the 2% increase in SOC during testing as NASA's facilities .....	37
Figure 33: Deceleration rate of the vehicle during regenerative braking from 130 kph to 20 kph.....	38
Figure 34: The figure on the left shows the velocity obtained with shift logic and the figure on the right shows without the shift logic .....	38
Figure 35: Motor torque generated without a custom shift logic.....	39
Figure 36: Motor torque generated with custom shift logic .....	40
Figure 37: Regenerative braking current with standard shift logic.....	41
Figure 38: Current generated with a custom shift logic.....	41
Figure 39: The left figure shows the 2% gain in SOC from the custom shift logic and the right shows the .5% gain in SOC with standard shift logic .....	42
Figure 40: Regenerative braking from 130 kph to 20 kph using brake pedal.....	43
Figure 41: Current generated during brake pedal regenerative braking .....	43
Figure 42: SOC increase during the braking event.....	44



## Limitations and Assumptions

Pacejka coefficients from generic tires.

Damping effects during weight transfer

## List of Acronyms

BMS	Battery management system
CAN	Controlled area network
EBD	Electronic brake-force distribution
EM	Electric machine
ESC	Electronic stability control
ICE	Internal combustion engine
IMG	Integrated motor generator
IVM	Initial vehicle movement
PHEV	Plug-in hybrid electric vehicle
RWD	Rear-wheel-drive
SIL	Software-in-the-loop
TCS	Traction control system

## Chapter I

### Introduction

#### Significance of the Study

Most of world's automotive manufacturers are expanding their research and development of hybrid and electric vehicles to decrease emissions. Along with this increase in production, there has been an ever increasing demand for hybrid and electric vehicles.

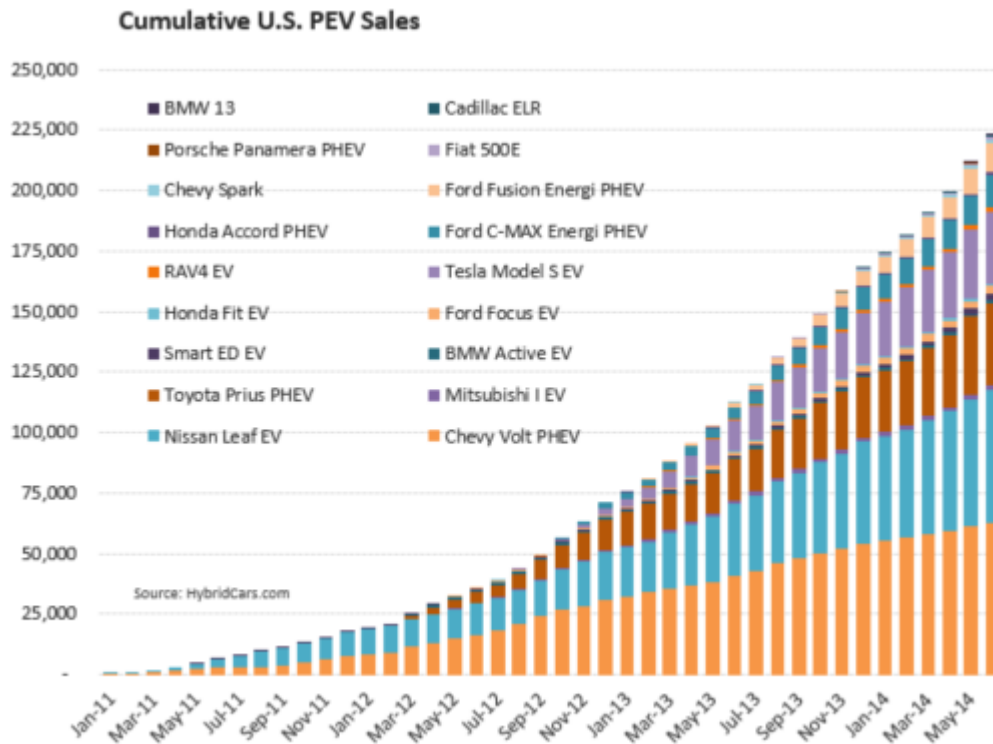


Figure 1: Manufacturers and total sales of electric vehicles [1]

The increase in production and demand for hybrid and electric vehicles to the development several different vehicle configurations and control strategies. This particular paper concentrates on a parallel-series plug-in hybrid electric vehicle with an

automatic transmission and integration of regenerative braking. In order to get the most from the regenerative braking, it is ideal to keep the motors in their most efficient region.

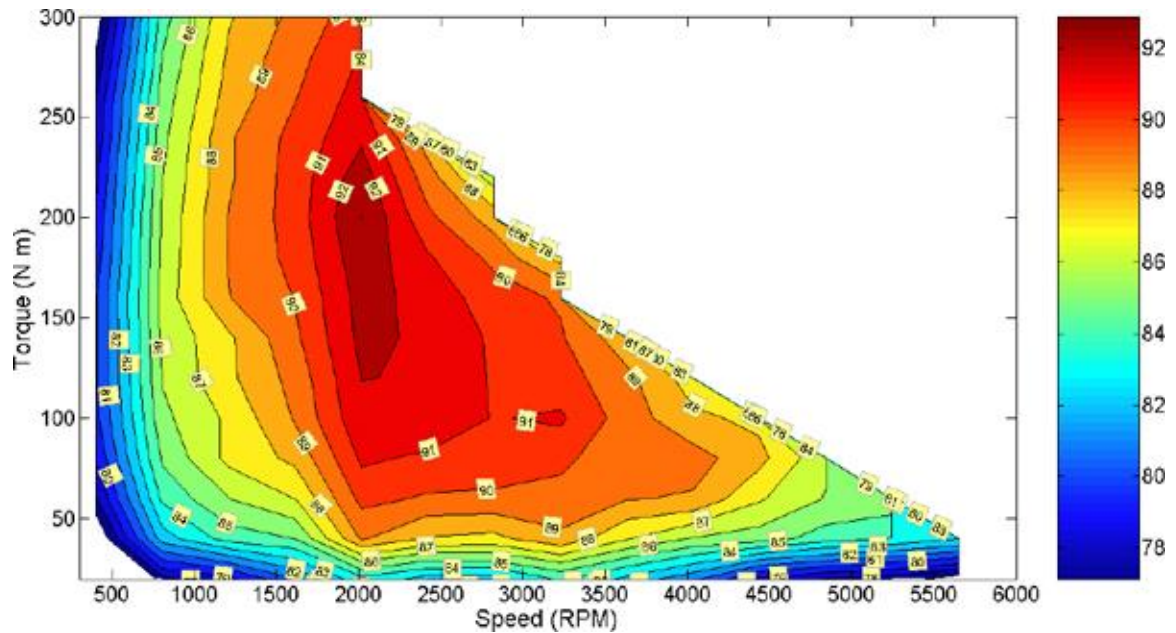


Figure 2: Efficiency plot of electric motors [2]

An automatic transmission is very beneficial in completing the task of maintaining a high efficiency in the motors because a custom shift logic can be generated to shift the transmission based on the rpm of the motors. This custom shift logic is integrated in with floating pedal regenerative braking, which gives the driver the ability to drive the vehicle with one foot.

### Statement of the Problem

During braking a hybrid vehicle would like to recover some energy through regenerative braking, however, integrating the regenerative braking with mechanical braking and an automatic transmission is no trivial task. A floating pedal regenerative brake controller must be designed to work with a custom a shift schedule to keep the motors in there most efficient range during regen. Regenerative braking must be added

to braking without making the deceleration too aggressive, but recover as much energy as possible.

### Purpose Statement

The purpose of this study was to develop a regenerative brake controller that system for a parallel-series plug-in hybrid electric vehicle with an automatic transmission. This was done by creating a floating pedal controller, custom shift logic, and brake pedal blended regenerative braking. The floating pedal utilizes vehicle speed, gear position, and wheel torque to adjust the amount of regen. The custom shift logic utilizes motor rpm and efficiency curves to determine when to shift the transmission. The brake pedal regen correlates brake pedal position to a regen torque and adds it to the hydraulic braking. All of this creates a regenerative brake controller for a parallel-series hybrid vehicle.

### Vehicle Architecture

The architecture design used in this study was designed around the rules and regulations of EcoCAR 3 competition. This is a four-year competition is sponsored by the U.S. Department of Energy, General Motors, and Argonne National Labs. EcoCAR 3 challenges sixteen universities to design a hybrid version of the 2016 Chevrolet Camaro that is as efficient as possible and still has the performance characteristics of a Camaro. This competition provides a great test bed for various hybrid vehicle controllers. Figure 3 shows the powertrain layout of Embry-Riddle's Camaro.

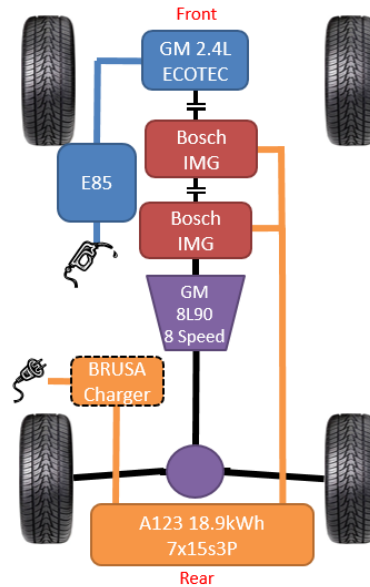


Figure 3: Vehicle architecture for Embry-Riddle ESS Chevrolet Camaro

Embry-Riddle's ESS Camaro utilizes a 2.4 E85 Ecotec from General Motors, coupled to two Bosch Integrated Motor Generators (IMG) by way of two hydraulically actuated clutches. The engine and motors are coupled to an 8190 8-speed General Motors transmission, which transfers the torque to the wheels. The system is powered by an 18.9 kWh A123 battery pack. The clutches in the powertrain design allow the vehicle to operate as a series or parallel hybrid. If the clutch between the two motors is open the car will be in series mode, so the engine will act as a generator and the car will drive all electric on the other motor. If all the clutches are closed the vehicle is in parallel mode, which means all the components are sending torque to the wheels. This type of powertrain layout allows for a lot of manipulation during regenerative braking by way of dual motors, clutches and a transmission. Figure 4 shows the power flow in series and parallel mode.

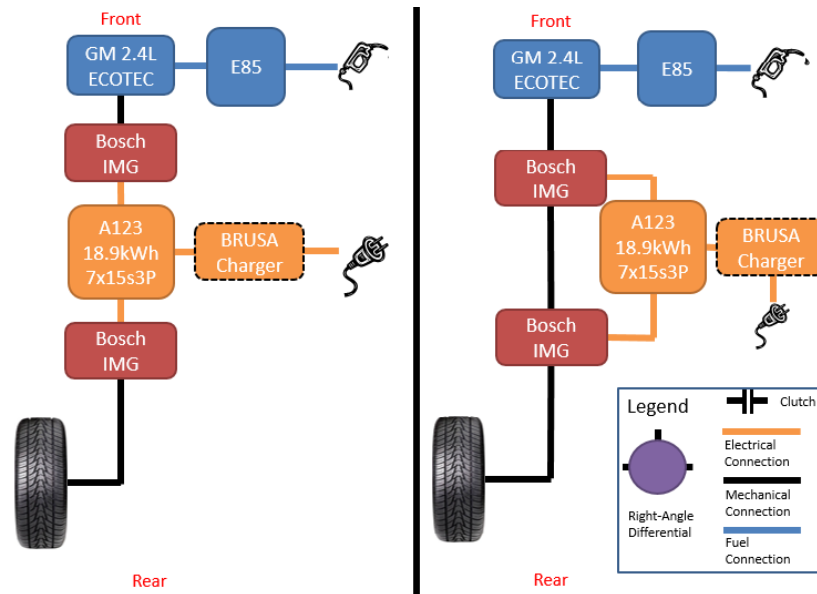


Figure 4: The left side of the figure shows the series mode configuration and the right shows the parallel mode configuration

## Thesis Statement

A hybrid muscle car with a multi-speed transmission requires regen strategies of a floating-zero pedal, custom shift logic, and hydraulic brake fusion to effectively recover energy during deceleration in Eco and Performance modes.

## Chapter II

### Review of the Relevant Literature

#### Regenerative Braking

One of the main causes of energy losses in a vehicle is braking. A more efficient way of braking can be used in PHEV's known as regenerative braking. Regenerative braking utilizes the motors to slow the vehicle, while recovering energy from the braking process to recharge the battery. This particular article uses a multi-lookup table approach to determining the amount regen to use under certain braking conditions. The tables use vehicle velocity and deceleration conditions to determine a coefficient to multiply the total braking force by to get front and rear braking. The front, rear, and total braking can be used to calculate the regen braking used in that particular condition. [3]

The essence of this literature is to develop a regen controller based on the maximum regenerative energy recovery. The controller is mainly based off a graph that graphs braking force distribution between front wheels and rear wheels, including electronic and mechanical braking. The graph also has lines for coefficient of friction, braking deceleration rate, mechanical braking curve, and ECE regulation curve. This graph then enables the controller to figure out how much regen braking is possible at that decal rate, so the maximum amount of energy is recovered. [4]

When working with a vehicle that has regenerative braking on the rear, stability of the vehicle during braking and cornering must be taken into consideration. This literature takes a look at creating a regenerative brake controller based on the stability characteristics of the vehicle. The controller takes a look at the yaw rate of the vehicle to determine the amount of regenerative braking to add or subtract from the braking or cornering maneuver. The controller works off a simplified car model and does a

relatively good job at controlling yaw stability, but doesn't use wheel lock as part of the controller. Wheel lock could take care of by letting ABS take over and not regening in ABS condition. Overall the literature is very informative on stability based regenerative brake controller. [5]

Just like in a rear-wheel drive car with regen, I front-wheel drive car with regen can have stability issues. If too much regenerative braking is applied the car may experience an understeer situation during cornering. This particular paper creates a regenerative brake controller based off the stability of the vehicle. The controller uses the car sensors for yaw rate and side slip angle and then uses the data to figure out an optimal brake torque distribution between the all the wheels and regenerative braking. Several of the same methods used in this controller can be applied to a rear-wheel drive hybrid. [6]

Effectively combining regenerative braking and mechanical braking has been an issue with hybrid vehicles. A plan proposed by this paper is to read in the slip ratios for the individual wheels and control the brake torque at each wheel. The controller also looks at the SOC, temperature of the battery pack, and the available regenerative brake torque. All of these values are sent through a fuzzy logic controller that can determine how much brake torque to apply to each wheel and how much of the brake torque can be regenerative braking. This method was tested on a custom car and the results show that controller works well. This particular method is the ideal situation for regenerative braking if you can control the amount of mechanical brake applied. [7]

This particular paper uses more of a mechanical method to integrate regenerative braking into the hybrid vehicle. To get the most regenerative braking, the mechanical braking needs to be varied as regenerative braking varies. A mechanical device was



created to decrease the front brake pressure when regenerative braking is activated. This is one most effective ways to implement regenerative braking because you can maintain the same braking torque and bias while recovering the maximum amount energy at that given time. The controller for this design takes wheel slip, battery temp, and SOC into consideration when determining the amount of regenerative braking that can be coupled to mechanical braking. This modified master cylinder design seems to be the future of regenerative braking. [8]

Another method for regenerative braking utilizes an electronic wedge brake and 6 speed automatic transmission. The electronic wedge braking allows for easy fusion of regenerative braking into the front braking. The wedge brake can be decreased and replaced with regen braking to maintain the same braking torque. The automatic transmission is also taken into consideration during regen. The transmission downshifts based on brake pedal stroke and vehicle speed during regen, which is very similar to the conventional method for automatic transmissions. The electronic wedge brake system helps with regen brake fusion and may be a possibility to add to a hybrid vehicle. [9]

Another mechanical solution for regenerative braking utilizes the brake hydraulic brake booster. The design for the system is based on varying the boost force generated in the brake booster independently of the driver braking force. This is done by an actuator on the vacuum line to the brake booster and controlling the pressure in the brake booster. The pressure in the brake booster correlates directly to the boost force on brake system. Regenerative braking can be blended in more effectively if boost force is decreased and replaced with more regen. This is a descent approach to blended regenerative braking. [10]

Instead of making mechanical changes to the vehicle to integrate regenerative braking, a custom controller for the ABS module could be utilized. The ABS module allows the control of the high-speed switch valves that pulse the brakes during an ABS braking situation. The switch valves can be used to vary the amount of hydraulic braking used during a deceleration event. This allows for hydraulic braking to be decreased and replaced with regenerative braking to maintain the same braking torque. This will internally increase the energy recovered from a deceleration event. This would be an excellent way to fuse the hydraulic and regen braking. [11]

Instead of making mechanical changes to the vehicle to integrate regenerative braking, a custom controller for the ABS module could be utilized. The ABS module allows the control of the high-speed switch valves that pulse the brakes during an ABS braking situation. The switch valves can be used to vary the amount of hydraulic braking used during a deceleration event. This allows for hydraulic braking to be decreased and replaced with regenerative braking to maintain the same braking torque. This will internally increase the energy recovered from a deceleration event. This would be an excellent way to fuse the hydraulic and regen braking. [12]

Regenerative braking can also be controlled by the throttle pedal. Regenerative braking will occur when the driver releases the accelerator pedal, which is very similar to engine braking in a standard automobile. This form of regen is very efficient for city driving, since there is a lot of starting and stopping. The release of the accelerator pedal will slow the vehicle to low speed and only minimal braking will be required, so maximum energy will be recovered. This can be done by attaching a switch to the accelerator pedal

that will trigger regenerative braking when the accelerator pedal is released. This form of regenerative braking is very promising in the hybrid world. [13]

This particular method takes a very different approach to regenerative braking in electric vehicles. This method utilizes a hydraulic pump attached to the drive shaft and an accumulator. The inertia of vehicle during a deceleration event drives the hydraulic pump and stores the braking energy in a hydraulic accumulator. The stored energy can then be released and sent to a hydraulic motor that will drive the car to a certain speed where the electric motors will take over. This is a very interesting concept that could be applied to a variety of hybrid vehicles. [14]

In regenerative braking the motor acts as a generator and it sends energy into the battery pack. The controller for regen monitors wheels speed, SOC, and charge buffer to calculate the braking torque required and possible during the given conditions. This system increases vehicle efficiency, reduces wear, decreases fuel consumption, and creates a more efficient means of braking. [15]

Regenerative braking can only be applied to the driven axle, which could cause instability in the vehicle during regen. Several different control strategies can be designed to utilize vehicle parameters to control regenerative braking. One strategy is to look at the wheel slip of the driven and compare it to the wheel slip of the non-driven wheels. The regenerative brake controller looks at the difference in the wheel slip and determines amount of regen to apply to the wheels. Another controller design could utilize the tire forces based off the normal forces on wheels and an assumed coefficient of friction. This is compared to the tire forces in the lateral and longitudinal direction to determine the slip force and the amount of regen to apply. The final method is to look at the yaw rate of the

vehicle and compare it to a reference yaw rate in vehicle state estimator. These yaw rates can then be used to dictate the regen. Each controller could be a possible solution to the instability caused by regenerative braking. [16]

The ability to diagnosis faults in regenerative braking process is extremely important in efficiency and vehicle stability. A fault diagnostic software looks at hardware, software, and communication faults during regenerative braking. This method then uses the data-driven method to detect and isolate the faults. Analysis of faults can be done to ensure that these problems don't occur again. [17]

The ability to recover kinetic energy is one of the main advantages of hybrid vehicles. During city driving more than half the energy can be dissipated to the brakes, which means there is a significant amount of energy that can be recovered. Regenerative braking can increase the efficiency and driving range of a hybrid vehicle. Various braking strategies can be implemented on a hybrid vehicle to improve the energy recovered during regenerative braking. [18]

Simulation of a regenerative brake controller is key before the actual implementation on a vehicle. This is done via hardware in the loop testing, which simulates the actual vehicle components. This particular regen controller is a for a parallel hybrid with a continuous variable transmission. The regenerative algorithm takes into consideration the battery state of charge, vehicle velocity, and motor capacity. The hydraulic system of car is varied by a reducing valve based of the regen controller. Also a stroke simulator is used to maintain the proper pedal fell when hydraulic braking is decreased and replaced with regen. Simulation results show that his regenerative brake algorithm provides sufficient braking and increased efficiency. [19]

Ideally a control strategy should seamlessly fuse hydraulic and regenerative braking to achieve the most efficient and best brake performance. A new cooperative braking strategy utilizes a brake torque distribution to better fuse the two braking systems. A sliding mode controller is used on the ABS system to adjust the hydraulic braking torque to maintain a certain wheel slip. A fuzzy logic controller adjust the regenerative braking system based on wheel slip, SOC, and motor speed. This system was simulated using Simulink and results show effective braking performance and increased efficiency. [20]

Not all hybrids are single speed gearboxes, so a control strategy must be developed to determine when to shift the transmission to get the most out of regenerative braking. A hierarchical approach is taken to both control the regen down shift and the brake blending. The upper controller looks at efficiency curves of the motor to determine the optimal time to downshift to increase the efficiency of regenerative braking operation. The medium controller uses sliding mode control to obtain the hydraulic brake torque. The lower controller is the fusion of the regen and hydraulic braking for effective braking and increased efficiency. [21]

Creating the most efficient vehicle is continually sought after when implementing regenerative braking, but vehicle stability is something that must be maintained with the added braking. Stability parameters of vehicle must be looked at and used to control the regenerative braking. One method is to use a phase-plane method to calculate optimal ABS braking. Then the targeted brake torque is divided into regen and friction braking, which creates a smooth fusion of braking. [22]

Transmissions in hybrid electric vehicles add some more complexity to the control algorithm, but can increase the efficiency during regenerative braking. A control algorithm for regen must consider the re-acceleration performance and the driving comfort. A proper regen controller must be developed to shift at optimal points for not only efficiency, but also drive comfort. A very high deceleration may create the most efficient deceleration, but may feel terrible to the driver. A deceleration rate of approximately  $3 \text{ m/s}^2$  is considered to be the max for comfortable deceleration. Simulation of the regenerative brake controller allows for tuning to maintain this deceleration rate. [23]

Many hybrids and electric vehicles are utilizing regenerative braking, so some studies have been done to prove the efficiency gains of the regen system. For this particular case study, a pure electric front-wheel drive car is used and drive cycle tested on a dyno. The study showed 11 percent gain in efficiency and a 13 percent gain in driving range. These are significant gains for regenerative braking. [24]

Several different strategies can be taken when designing a controller for regenerative braking. Three common strategies are the maximum-regeneration-efficiency, good-pedal-feel, and the coordination strategy. ECE drive cycles were used as a comparison for the control strategies. The maximum-regen strategy recovered a lot of energy, but caused problems with brake comfort and safety. The good-pedal strategy reduced energy recovery, but improved brake comfort. The coordination strategy increased regenerative brake efficiency. Overall regenerative braking improved fuel economy by 25% during these drive cycles. [25]

With the increase in hybrid vehicles, new regenerative brake control strategies are being developed. A modified control strategy is compared to a baseline regenerative brake controller by running a simulated ECE drive cycle. The modified reaches an efficiency 15 percent higher than the baseline and enhanced the fuel economy by an additional 3 percent. The modified strategy will soon be implemented on new vehicles in China. [26]

## Vehicle Dynamics

Modeling of a tire and tire forces is not a trivial task, but a set of mathematical formulas have been developed to create a linear tire model. These formulas allow for the calculation of longitudinal, lateral and camber slip conditions to be calculated. The coefficients in these equations can be changed to best represent your vehicles tires. This tire model is very critical in creating a proper vehicle dynamics model. [27]

## Chapter III

### Methodology

The first step in solving the problem with regenerative braking is developing a Mathworks Simulink model of the vehicle. A model of the vehicle enables a controller for regenerative braking to be created and tested in various situations before it is implemented on the actual vehicle.

#### Vehicle Body Model

The model is a seven degree of freedom model that makes up for some vehicle properties that the bicycle model doesn't take into consideration, such as lateral weight transfer and left/right braking forces.

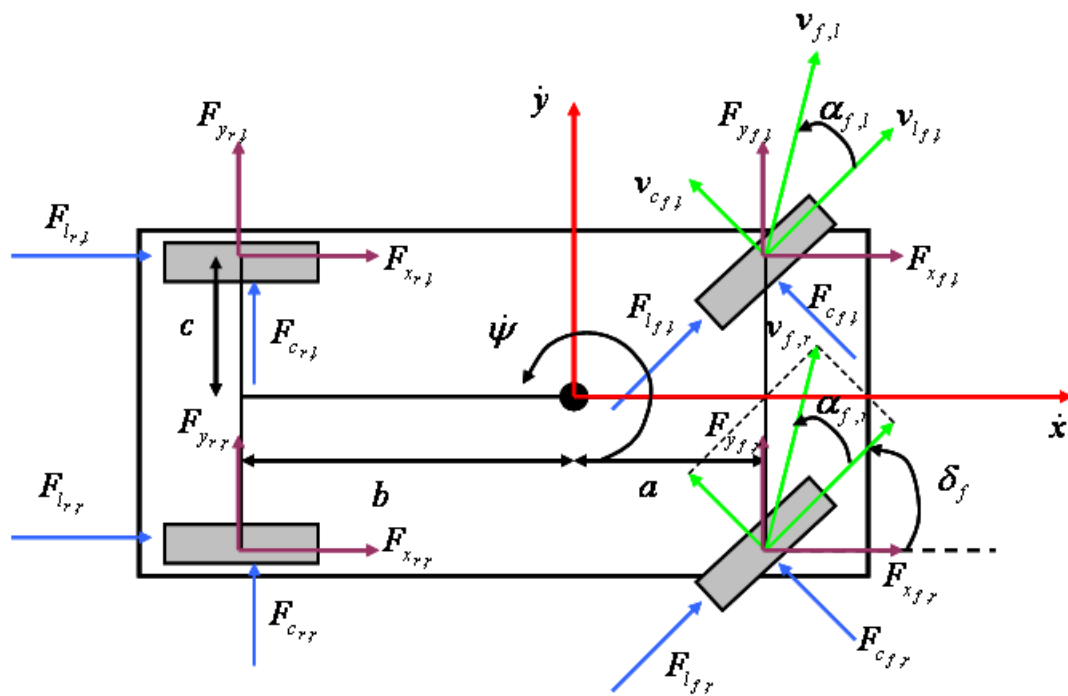


Figure 5: Diagram of the vehicle forces [3]

The first subsystem of the model is an axle subsystem that calculates individual wheel angular velocities. The model block uses the axle torque, tractive forces and brake



pressure to determine the as inputs from the car to calculate angular velocities of each wheel. Figure 6 shows the axle subsystem block in the model.

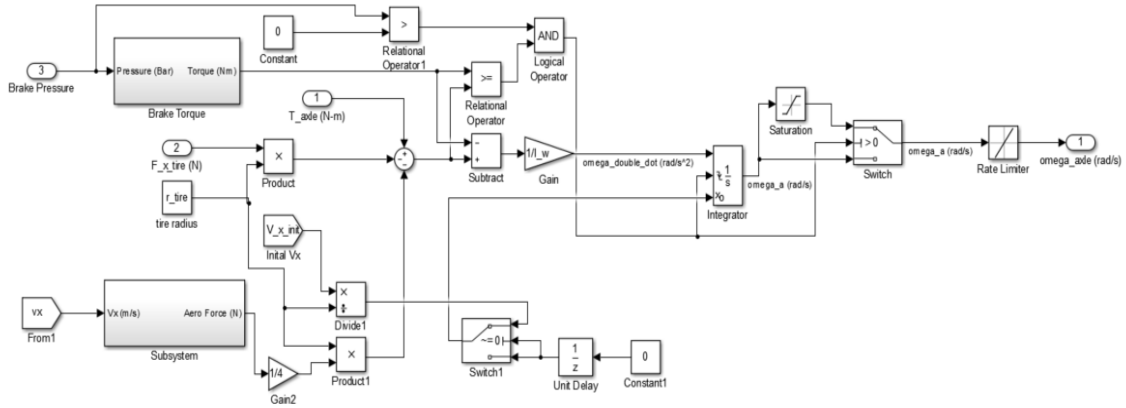


Figure 6: Rotational subsystem of vehicle dynamics model

$$\Omega = \int \frac{\tau_{tractive} - (F_x r_{dym}) - F_{road load} - \tau_{brake}}{rotational inertia}$$

Where:

$\tau_{tractive}$  = torque from powertrain

$\tau_{brake}$  = torque form brakes

$F_x$  = longitudinal force from pacejka tire model

$F_{road load}$  = aerodynamic road load

$r_{dyn}$  = dynamic rolloing radius

The aerodynamic load in the equation calculated based of GM data.

$$F_{road load} = F_0 + F_1 v_x + F_2 v_x^2$$

Where:

$$F_0 = lbf$$

$$F_1 = lbf/mph$$

$$F_2 = lbf/mph^2$$

The wheel angular velocities are then sent to the velocity kinematics subsystem, which uses the angular velocity, body velocities, and steering angle to calculate the velocity and slip ratio at each wheel. Figure 7 shows the wheel velocity block.

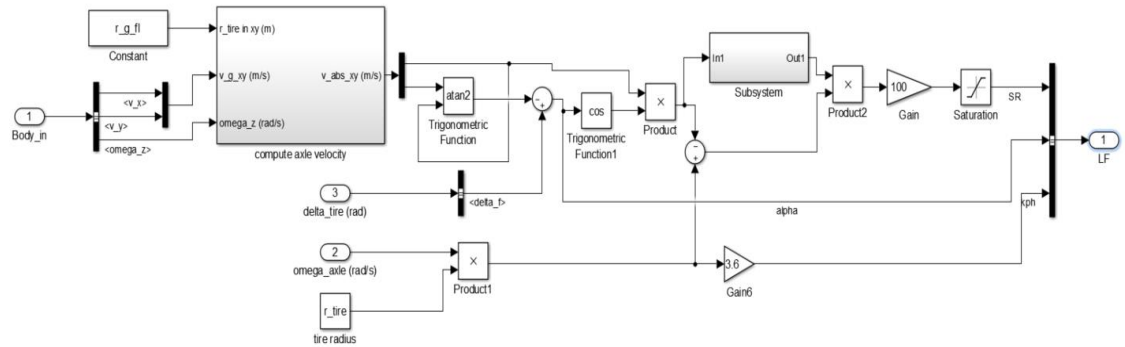


Figure 7: Converting vehicle speed and angular wheel velocity to longitudinal and lateral wheel velocities

The wheel slip is calculated using the equation below

$$\lambda = \frac{\omega_R r_{dyn} - v_x}{\omega_R r_{dyn}}$$

Where:

$\omega_R$  = angular speed of the wheel

$r_{dyn}$  = dynamic rolling radius

$v_x$  = longitudinal velocity

The next part of the model is to sum all the forces in the body fixed frame, but this can't be accomplished without wheel normal forces, which comes from a weight transfer model block. Figure 8 shows the longitudinal weight transfer calculation.

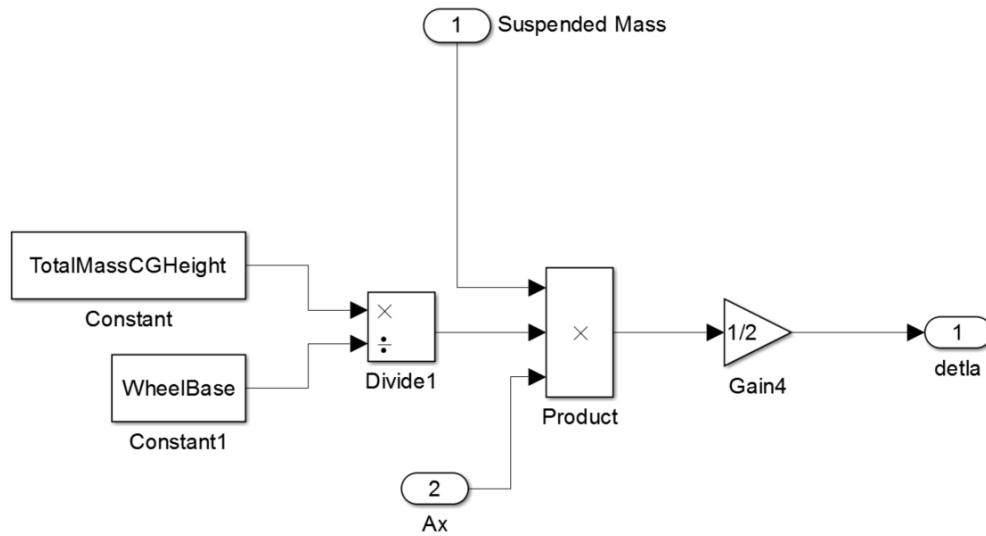


Figure 8: Longitudinal Weight transfer subsystem

The lateral weight transfer block uses the anti-roll moment from springs, anti-roll bar, suspended mass and unsuspended mass. The calculation of lateral weight transfer is shown in the figures below.

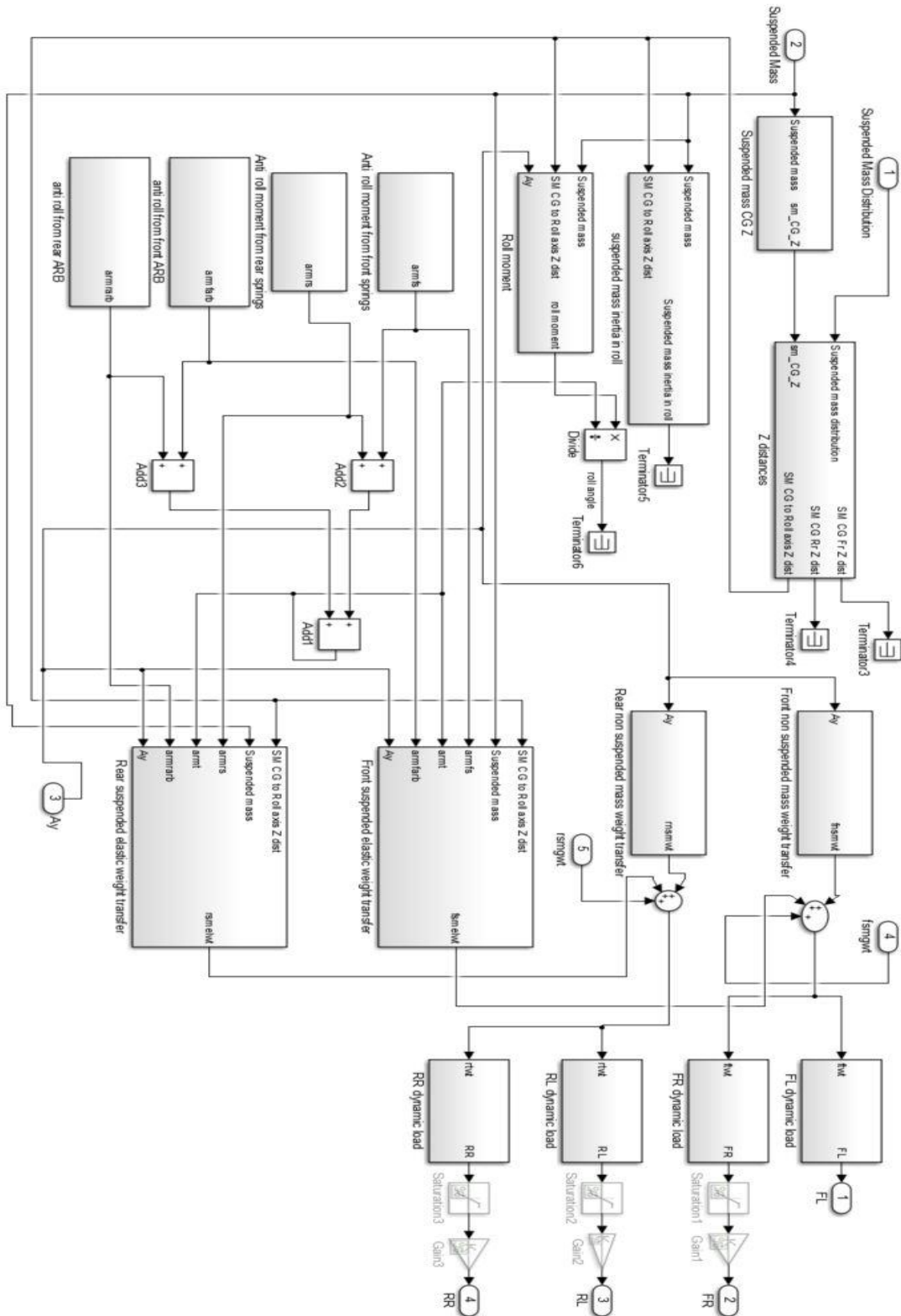


Figure 9: Lateral weight transfer block

Now that the normal forces have been determined, the next block in the model uses the normal forces, slip ratio, and slip angle at each wheel to determine the lateral and longitudinal forces. This is all done using the Pacejka tire model shown below.

$$F = F_z \cdot D \cdot \sin(C \cdot \tan^{-1}(B \cdot slip - E \cdot (B \cdot slip - \tan^{-1}(B \cdot slip))))$$

Where:

$F_z = \text{normal force on tire}$

$B = \text{Pacejka stiffness factor}$

$C = \text{Pacejka shape factor}$

$D = \text{Pacejka peak factor}$

$E = \text{Pacejka curvature factor}$

The Figure 10 shows the calculation and summation of all the lateral and longitudinal tire forces in the body-fixed frame.

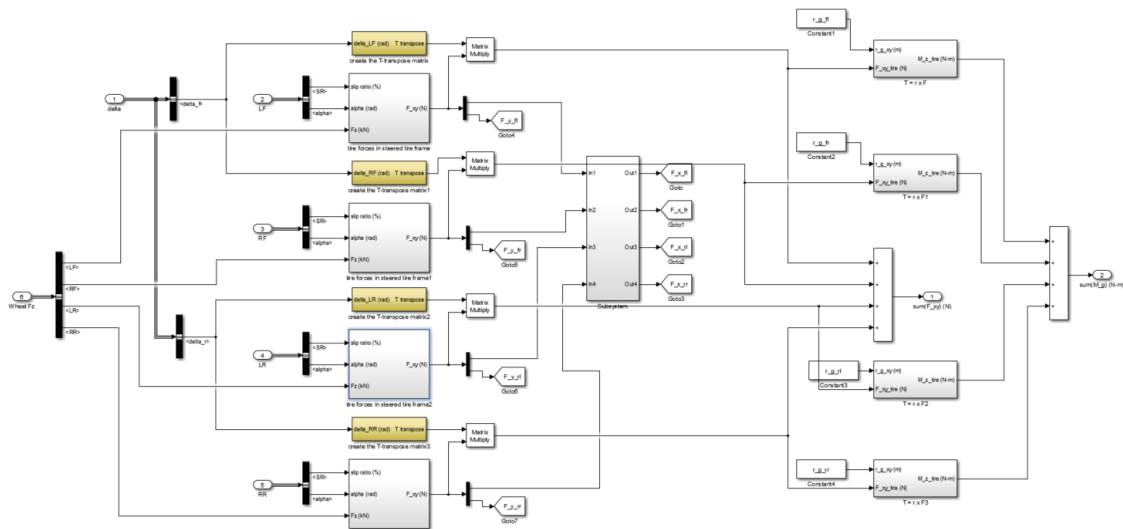


Figure 10: Calculation and summation of the lateral and longitudinal wheel forces

The sum of forces and moments that come out of this Pacejka block can then be used to calculate the vehicle lateral velocities, longitudinal velocities, and the yaw rate.

Figure 11 shows the velocity calculation in the body fixed frame.

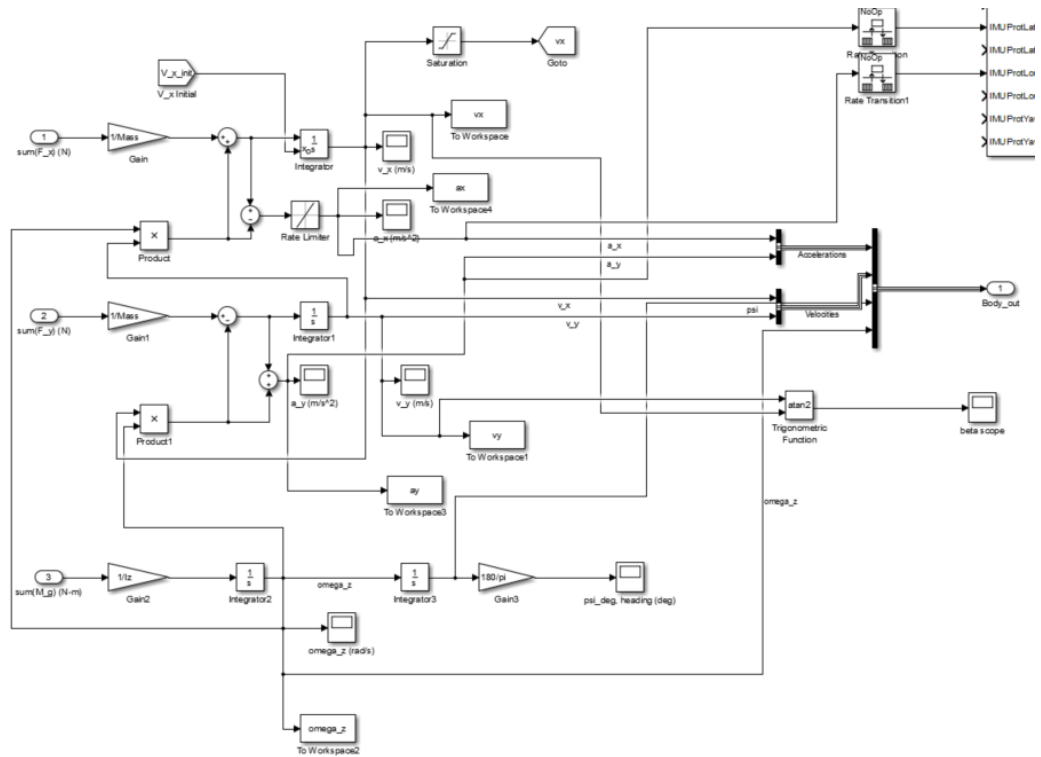


Figure 11: Calculation of vehicles velocities based off longitudinal and lateral velocities

The equations used to calculate the lateral and longitudinal velocities are shown below.

$$v_x = \int \frac{\sum F_x}{Mass}$$

$$v_y = \int \frac{\sum F_y}{Mass}$$

The velocities are then fed back to the beginning of the model to start the calculations again. The body-fixed velocities are also converted to the inertial frame to calculate vehicle position, so it can be displayed in relation to a start point.

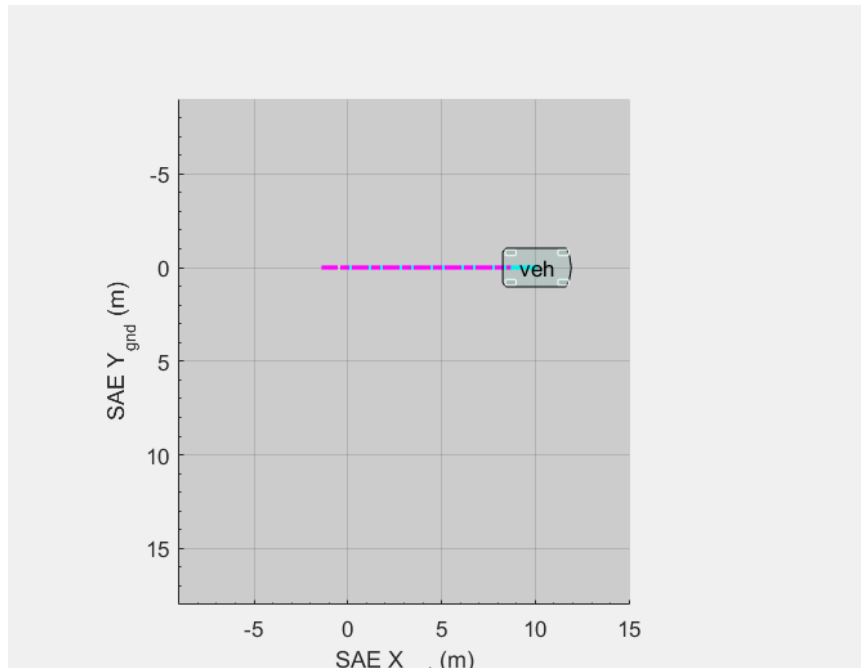


Figure 12: Vehicle driving animation

### Powertrain Model

In order to actually utilize the vehicle dynamics model and to develop a regenerative brake controller, a powertrain model had to be developed. The model is made up the major components of the parallel-series hybrid powertrain, which includes a GM LEA engine, two Bosch IMG motors, two hydraulic clutches, 8L90 transmission, differential, and an A123 battery pack.

The first major component is the GM 2.4L Ecotec engine. The engine is essentially made up of a lookup tables of torque curves vs. intake port flow and RPM. The model feeds a pedal position and rpm into the engine model, which uses these values in lookup tables to produce a torque value from the engine. Figure 13 and Figure 14 show the engine model and the lookup tables.

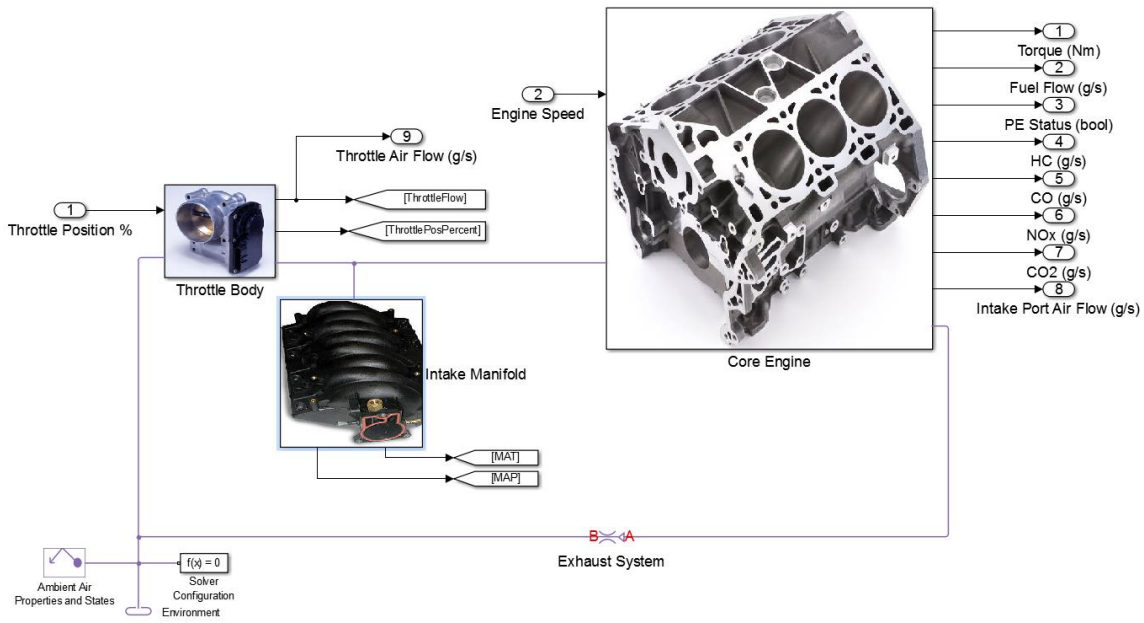


Figure 13: Engine model

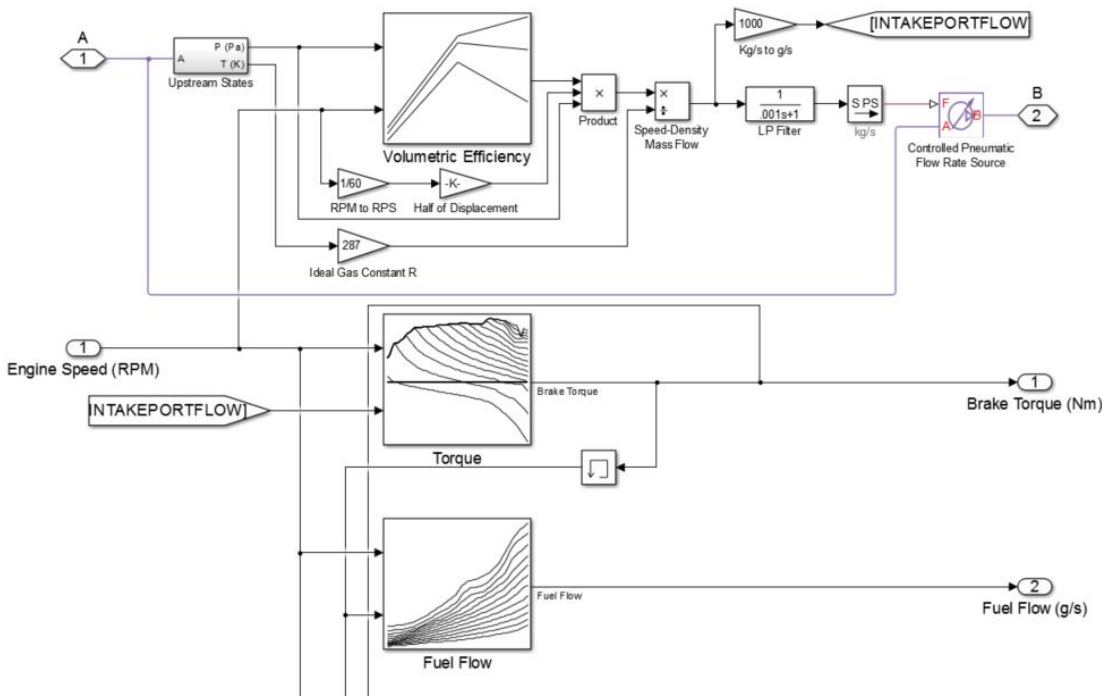


Figure 14: Lookup tables for the engine

The next part in the powertrain is the Bosch Integrated Motor Generator (IMG), which also uses a series of lookup tables to determine motor torque. The torque tables are



based on voltage, RPM, and efficiencies of the motors. The desired torque by the driver is saturated by the max torque available during motoring and regenerative braking. Figure 15 shows the motor configuration.

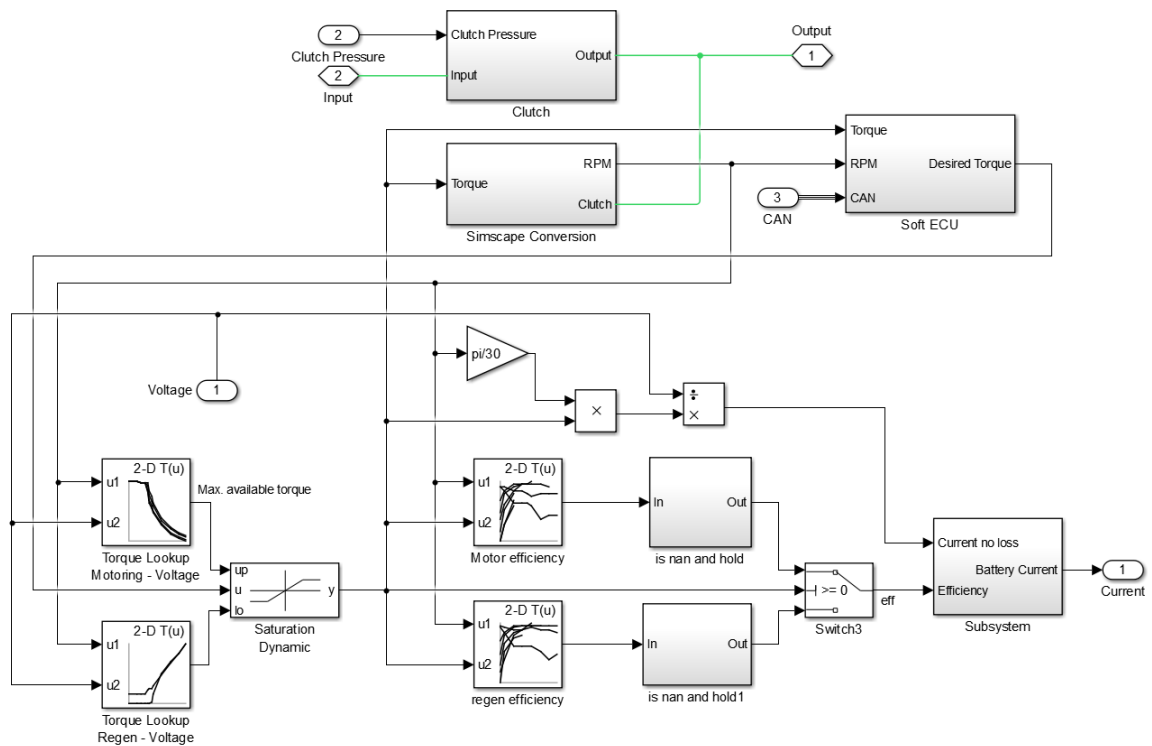


Figure 15: Bosch IMG subsystem, which is made up of lookup tables

In order to link the motors and engine together a series of clutches were used. The clutches are modeled as Simscape friction clutches that are normally closed and opened at 14 bar of pressure.

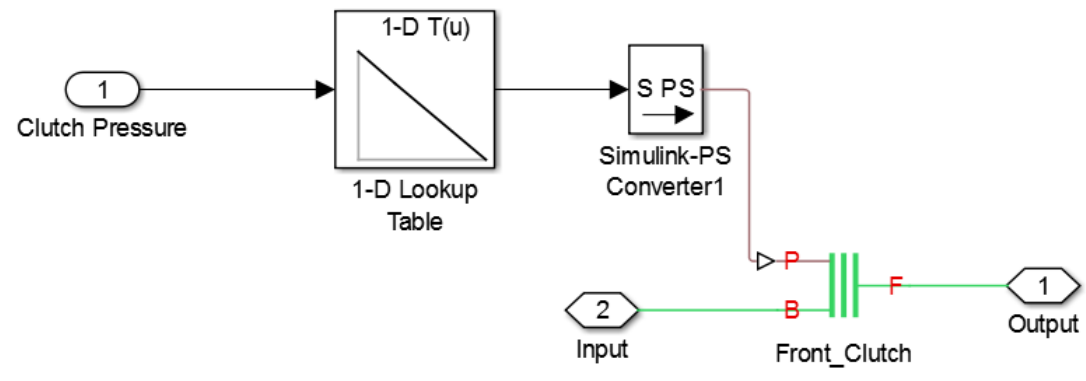


Figure 16: Block for friction clutches between motors

Further down the powertrain is the 8I90 GM transmission and the 2.77 final drive ratio differential. The transmission is made up of a Simscape torque converter, clutch inertia and a variable speed gear box. The torque from the motor and engine is transmitted through the transmission and then to a Simscape differential and then on to the axles. Then the torques and velocities are fed into the vehicle dynamics model. Figure 17 shows the transmission model.

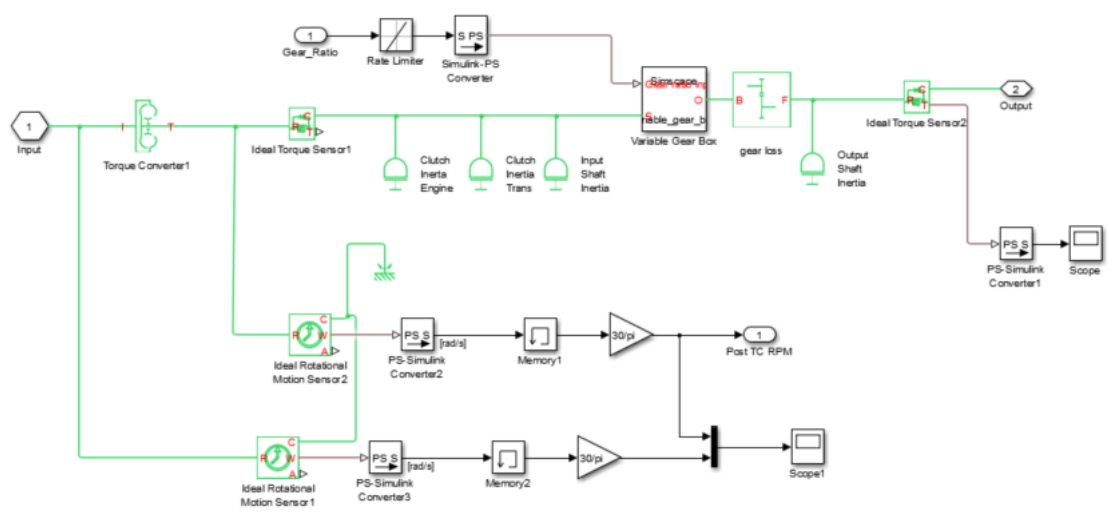


Figure 17: Transmission subsystem

The final part of the powertrain is the A123 battery pack, which is comprised of a lookup table based on voltage and current. The battery model calculates the power using the current and voltage and subtracts out losses to internal resistance at a given current draw. Figure 18 shows the overall layout of the battery model.

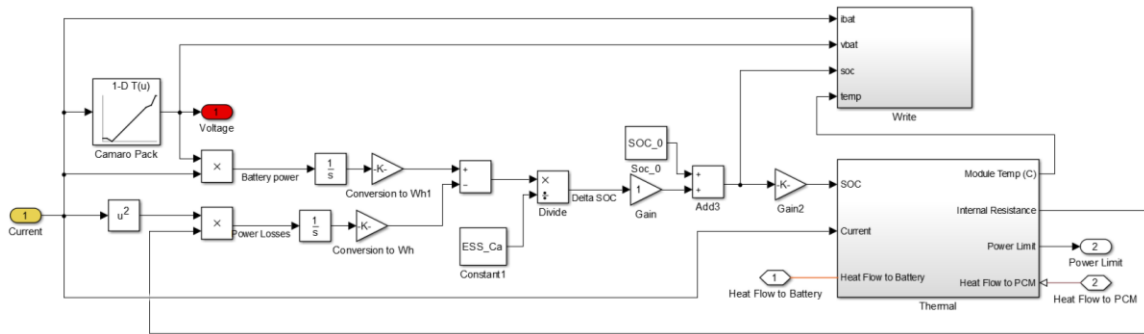


Figure 18: Battery model

### Regenerative Brake Controller

The first part of the regenerative brake controller is to develop a floating pedal regen for city driving. A floating pedal controller essentially provides regen as soon as you let off the gas pedal and the amount of regen varies with speed, rpm, and the amount of regen torque available at the given moment.



Figure 19: Regenerative braking subsystem

The model feeds in desired torque, speed (mph), regen disable, ABS active, SOC, RPM, and gear position. The desired torque request is based off throttle position and sent to a linear lookup table that correlates the throttle position to a torque request. The speed in miles per hour is read from on the wheel speed sensors. The regen disable button gives the driver the ability to turn the regen on and off. ABS active is sent to the regen controller to disable it under ABS braking situations. The SOC is sent in to disable regenerative braking when the state of charge exceeds 99%. Finally, the gear position is sent in to be used in controlling the regen. Figure 20 shows the pedal remapping.

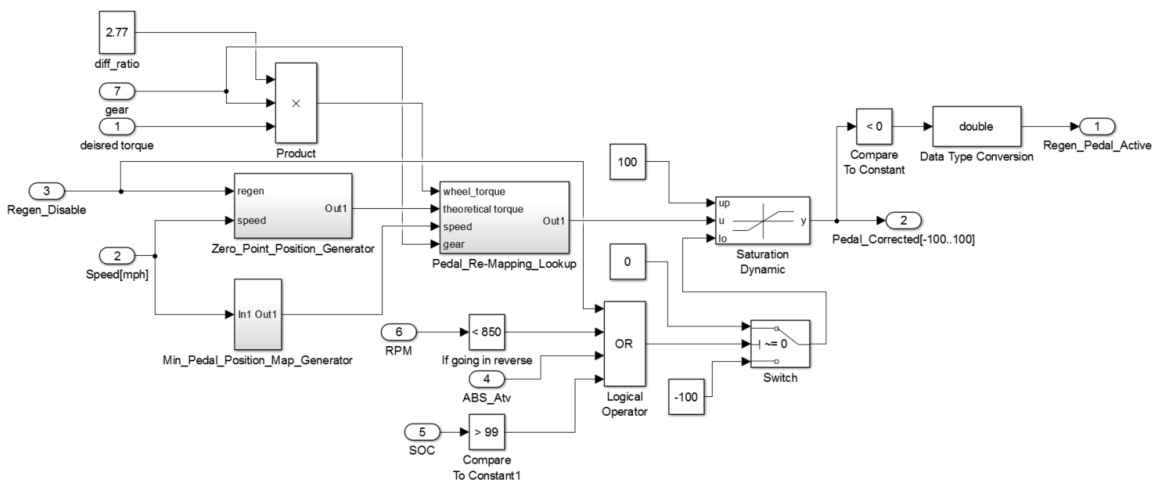


Figure 20: Floating pedal regenerative braking

The desired torque is sent in and multiplied by current gear ratio and final drive ratio to determine the desired wheel torque, which is sent into the pedal remapping subsystem. The speed is sent into a subsystem to calculate a new zero point based on the wheel torque required to maintain that speed.

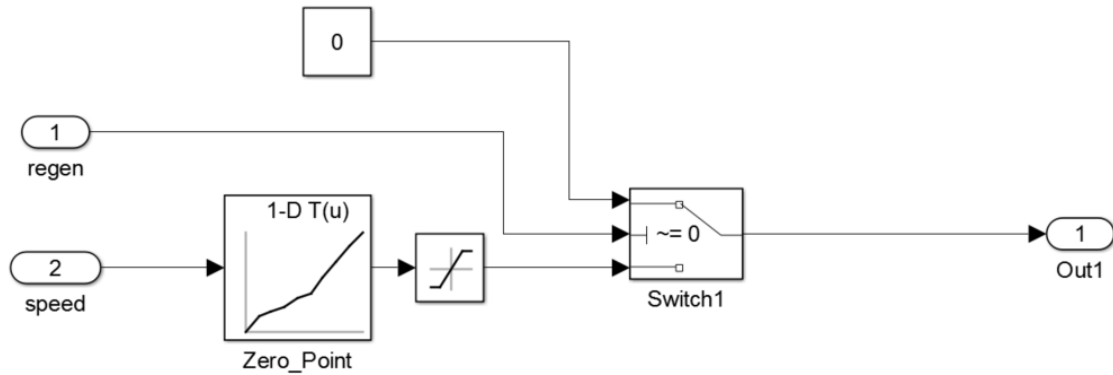


Figure 21: Zero point subsystem to remap pedal

The speed is also sent into a subsystem that uses a tanh controller to convert the speed to a value between 0 and -40 to create a new minimum pedal position. The results from the zero-point subsystem and min pedal position are sent into the pedal remapping subsystem. There is also a series of fault cases to disable regen based on RPM, SOC, and ABS activation. Figure 22 is the remapping subsystem.

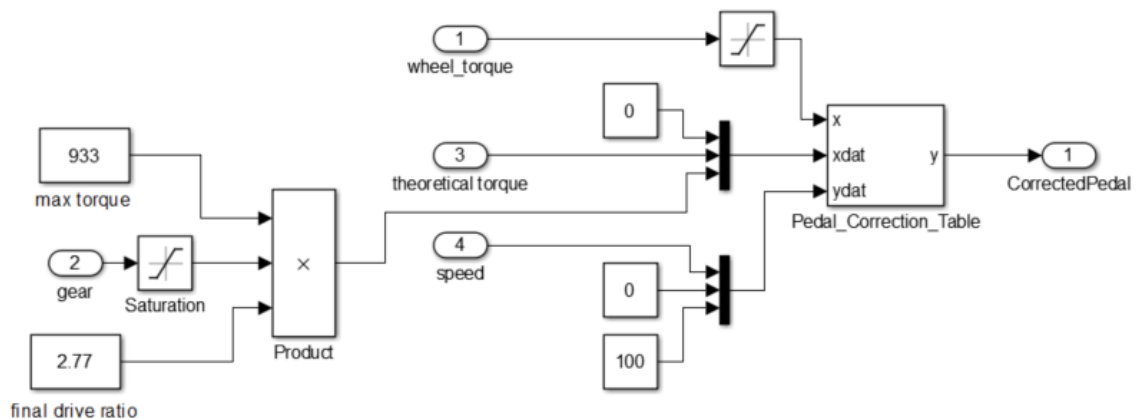


Figure 22: Dynamic lookup table to generate a floating zero pedal map

As shown above the values are sent into a dynamic lookup table that continually remaps the pedal based on speed. If the car is regening the corrected pedal will send out a negative value that can be converted to a negative torque.



The remapped pedal is then sent back to the linear desired torque curve to pull out a negative torque based on throttle position. The torque is sent through a series of torque limiting lookup tables based on SOC and RPM. Before the torque is actually applied it is sent through a saturation based on calculated regen torque available.

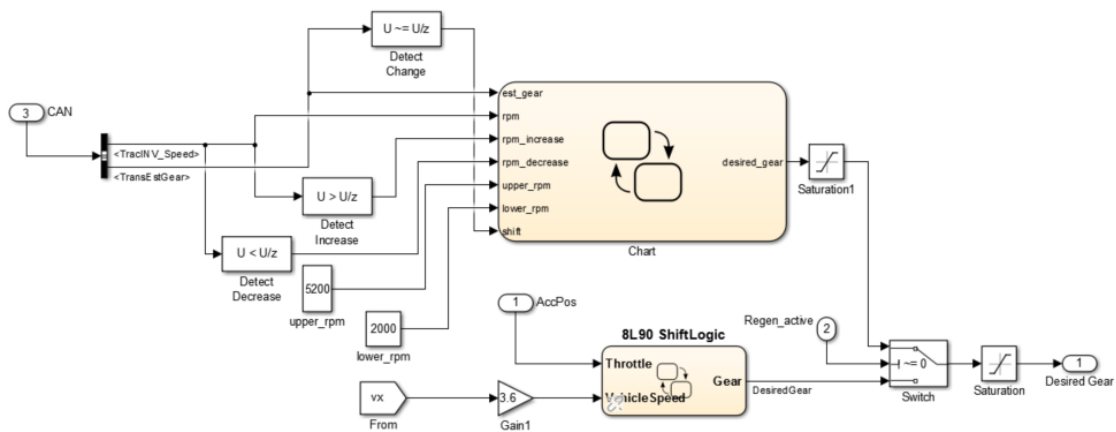


Figure 24: Custom shift logic regen

In order to get the highest efficiency from the motors, a custom shift logic was created. A signal from the pedal remapping subsystem is sent to shift schedule to tell the controller that regenerative braking is active and to switch shift schedules. The shift controller works by up shifting or downshifting based on the rpm range that is most desirable for the motors. The key to recovering the most energy is keeping the motors in their efficiency range, which is what the shift controller does by looking at motor rpm.

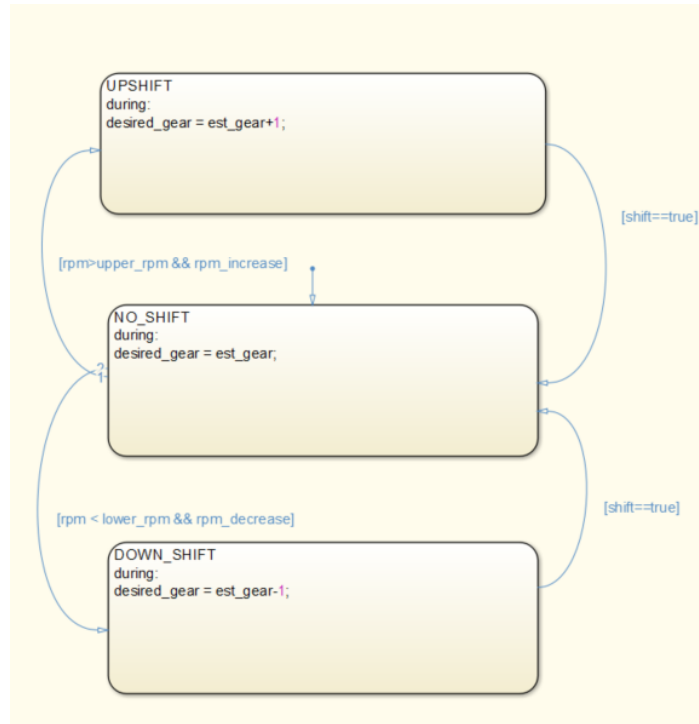


Figure 25: State flow of shift logic

The next part of the regenerative braking was to integrate it into the brake pedal. The same logic conditions were applied to the brake pedal regen, which means regen disable, ABS, and SOC can disable regen braking. The brake pedal position was then sent into a lookup table to determine the appropriate regen torque to apply. The brake position is also used to trigger between floating pedal regen and regen by brake pedal. The braking regen is also saturated by the calculated regen torque available.

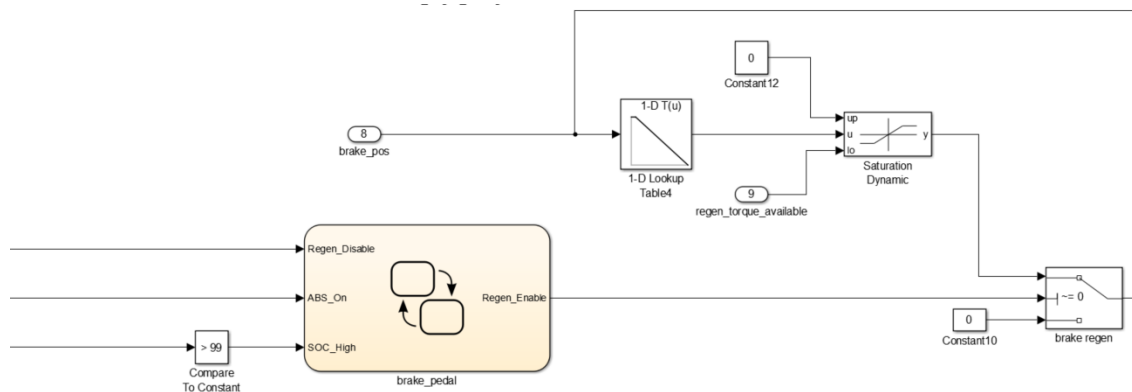


Figure 26: Regen with brake pedal



## Model Validation

In order to prove the model, a zero to sixty comparison was done with data we collected from the TRC testing facilities. The torque values from the TRC testing were fed into the model and the velocities and times were graphed in relation to one another. Figure 27 shows that model it pretty close with the exception of the initial launch of the vehicle. These difference can partially be attributed to the Pacejka tire approximation.

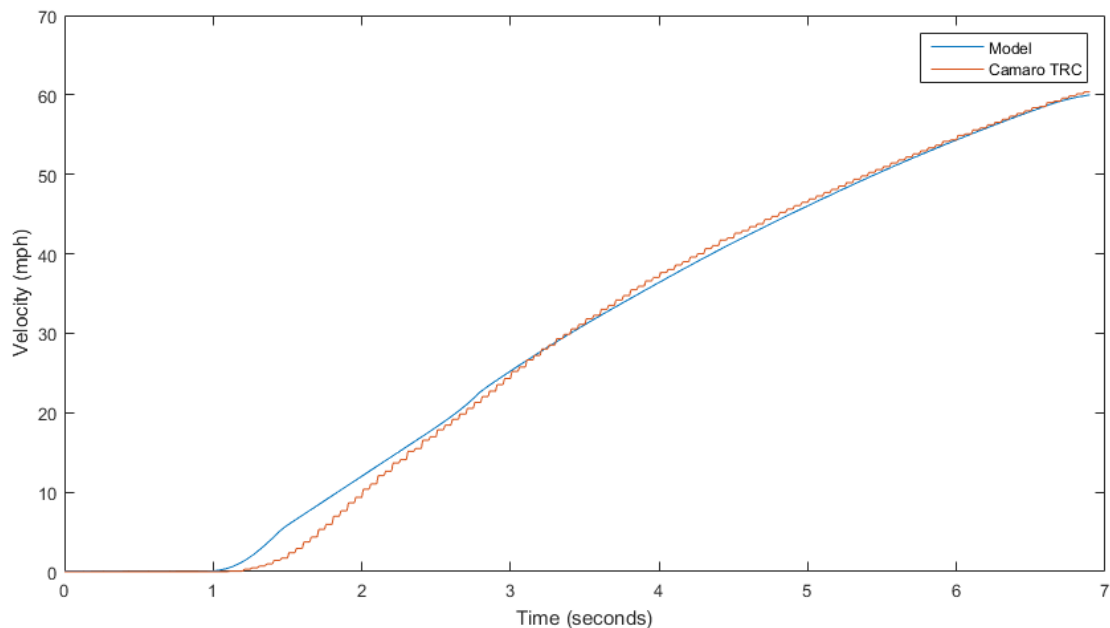


Figure 27: 0-60 comparison for model validation

## Vehicle Testing

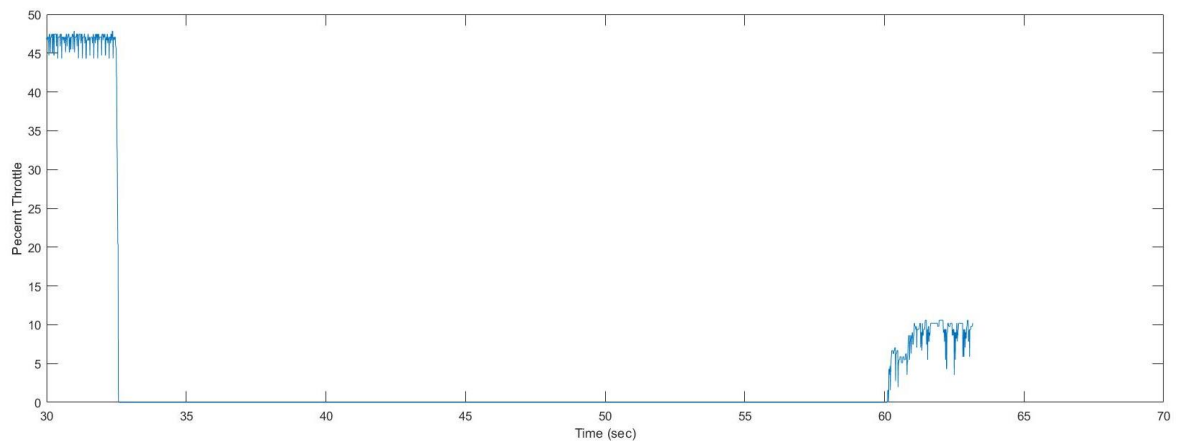
Testing has been completed at TRC testing facilities and NASA's shuttle launch facilities. The testing at TRC was done previous to the implementation of the regenerative brake controller, but the data from the testing was analyzed and used to further validate the Simulink model. With the model validated, the regenerative brake controller was created and implemented into the model.

NASA's shuttle launch facilities were used to test the regenerative brake controller on the vehicle. The vehicle was driven up to eighty miles per hour and then the driver let off the accelerator pedal, which causes regen through the floating pedal controller. The vehicle was allowed to regen down to fifteen miles per hour, which allowed for the collection of regen current, torque, gear position, and motor speed. The slow-down from 80 to 15 allowed for the vehicle to apply the regen shift logic to every gear and for the driver to experience the jerk rates as the regen changed per each gear shift. Rate limiters on regenerative brake torque were tuned to ensure a smooth and comfortable deceleration rate for the driver. NASA's facilities allowed for a significant amount of tuning to be done to regen controller and the collection of a lot of data to further validate and tune the model.

## Chapter IV

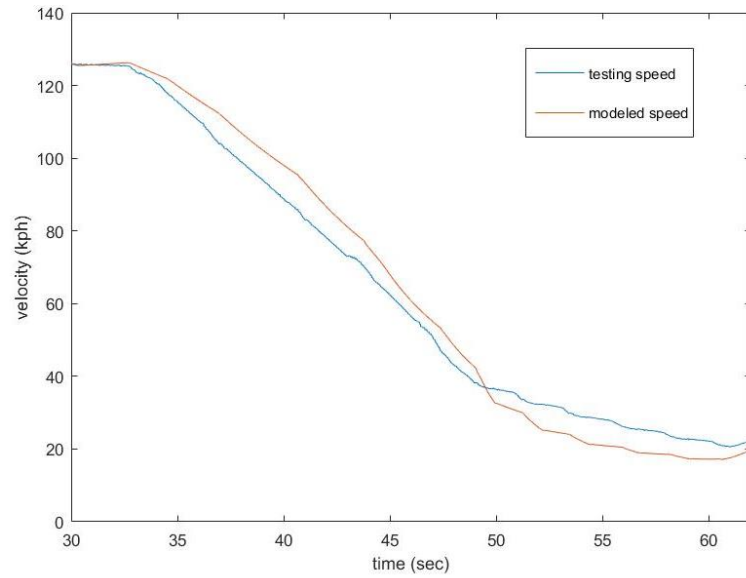
### Results

The data collected during testing proved that regenerative braking worked and the results are similar to the modeled results of the regen controller. The graph shown in Figure 28 is the accelerator pedal position from testing at Kennedy Space Center that was fed into the model to compare the results.



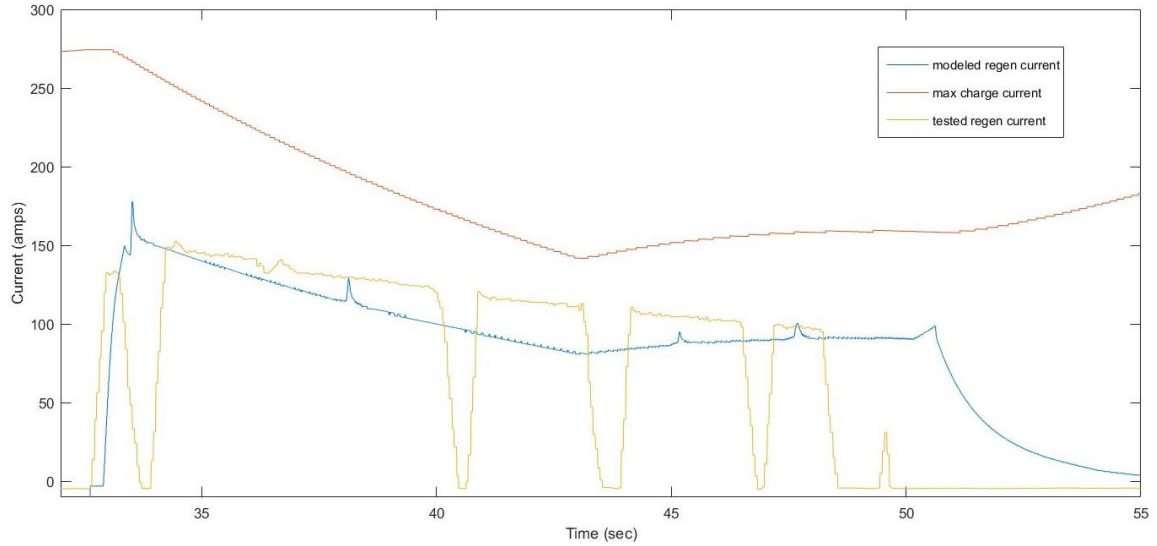
**Figure 28: Accelerator pedal position during deceleration**

The main concern is the deceleration portion, where both the modeled and testing data have essentially the same slope. The deceleration portion of the graphs uses the custom regen shift logic, which worked in both the model and real world testing. Figure 29 is a velocity comparison between modeled regen and the regen at NASA's facilities



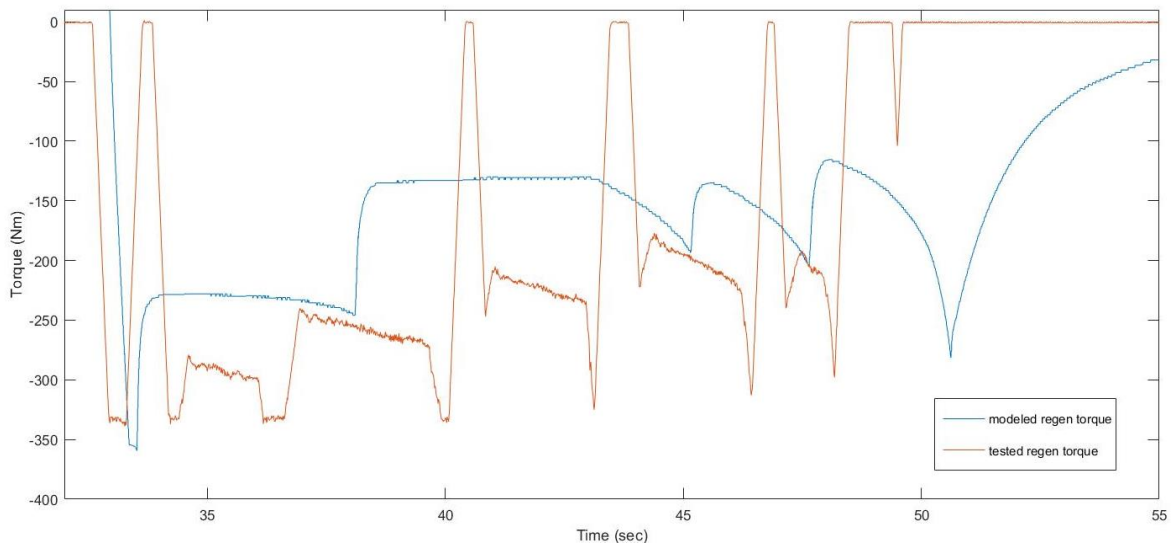
**Figure 29: Velocity comparison between model and testing during regenerative braking**

The vehicle speed gives a good visual to compare the modeled regen and testing regen, but more important characteristics are regenerative braking torque, current, and SOC. The graphs below show the current trace during regen from the model and data collected from Kennedy Space Center. The graphs show that the max current achieved during regen was within 7% of the modeled regenerative braking current. Not only is the max current close, but the current trace follows a similar trend of current decrease. One main difference is the actual car data includes torque cuts requested by the transmission, which is not compensated for in the modeled regenerative braking.



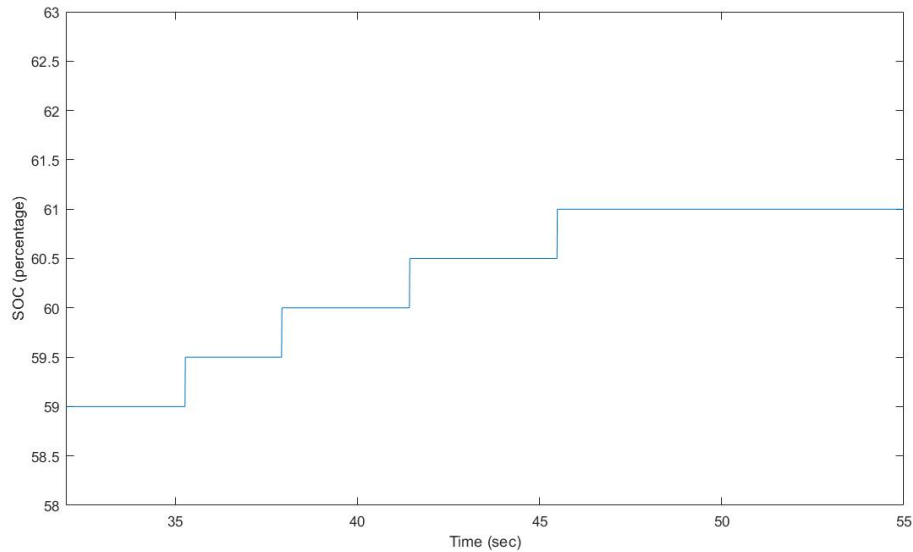
**Figure 30: Modeled current trace vs. current trace from testing**

The negative torque generated during regenerative braking is another good parameter of comparison for the regenerative brake controller. The graphs below show how the negative torque varies during a deceleration event. The max negative torque achieved during testing is within 4.5% of the modeled negative regenerative braking torque. Also both graphs show a similar torque trend, but with some differences do to the transmission requesting torque cuts during testing.



**Figure 31: Comparison of modeled regen torque and regen torque from testing**

Since the goal of regenerative braking is to charge the battery, an increase in state of charge is could metric for measuring the quality of regen control logic. Figure 32 shows that there was 2% increase SOC during a single deceleration event from 120 Kph to 20 Kph.



**Figure 32: Graph of the 2% increase in SOC during testing as NASA's facilities**

Finally, the regenerative braking algorithm was able to recover as a significant amount energy while maintaining a comfortable deceleration rate. According to the Bosch Automotive Handbook a max deceleration rate of  $3\text{m/s}^2$  is considered to be a comfortable deceleration, so the controller was tuned to maintain a deceleration rate less than or equal to  $3\text{m/s}^2$ . Figure 33 shows the deceleration rate during the tested deceleration event.

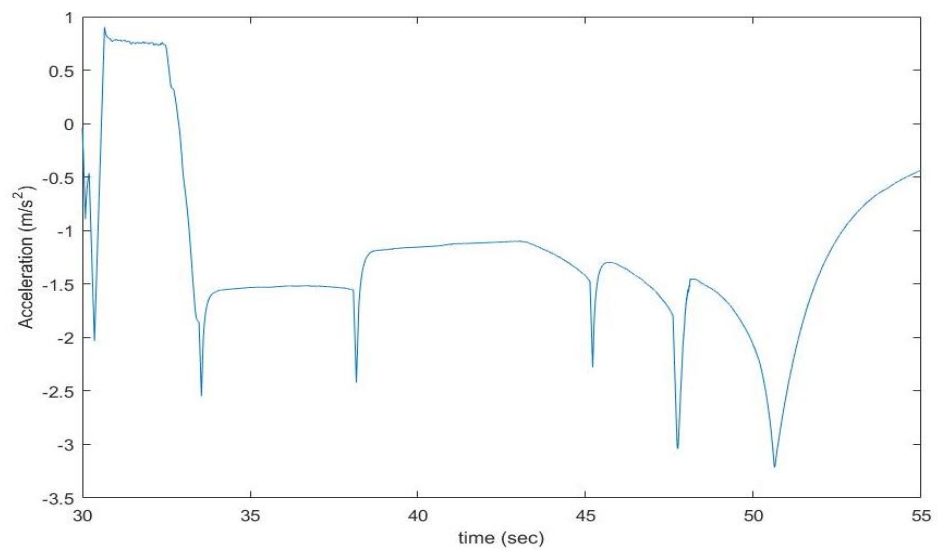


Figure 33: Deceleration rate of the vehicle during regenerative braking from 130 kph to 20 kph

### Comparative Analysis with and Without Shift Logic

Initially the regenerative brake controller was designed without a custom shift logic, but initial simulation results showed that a shift logic was needed. The graphs below show a velocity comparison using the same accelerator pedal map used in previous testing.

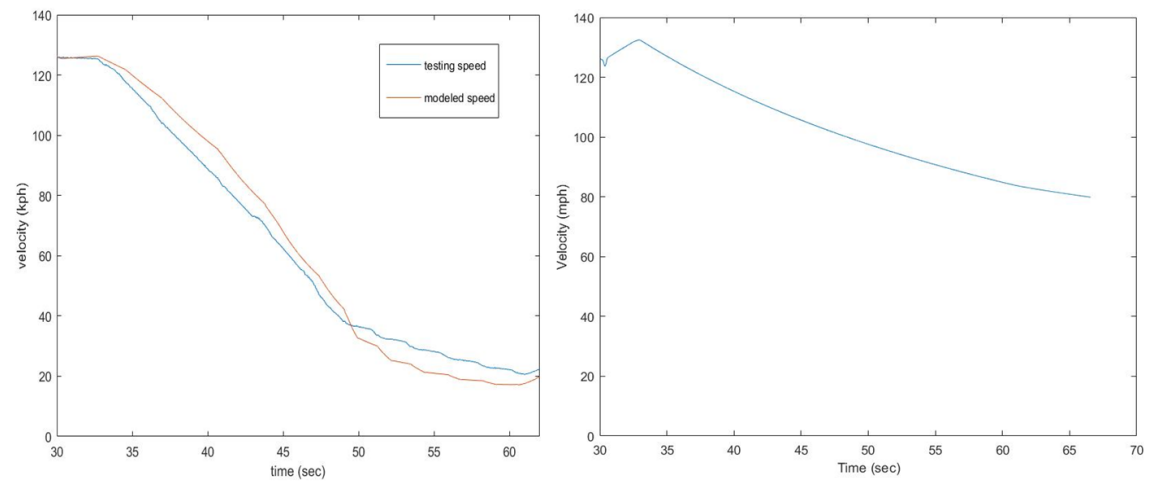
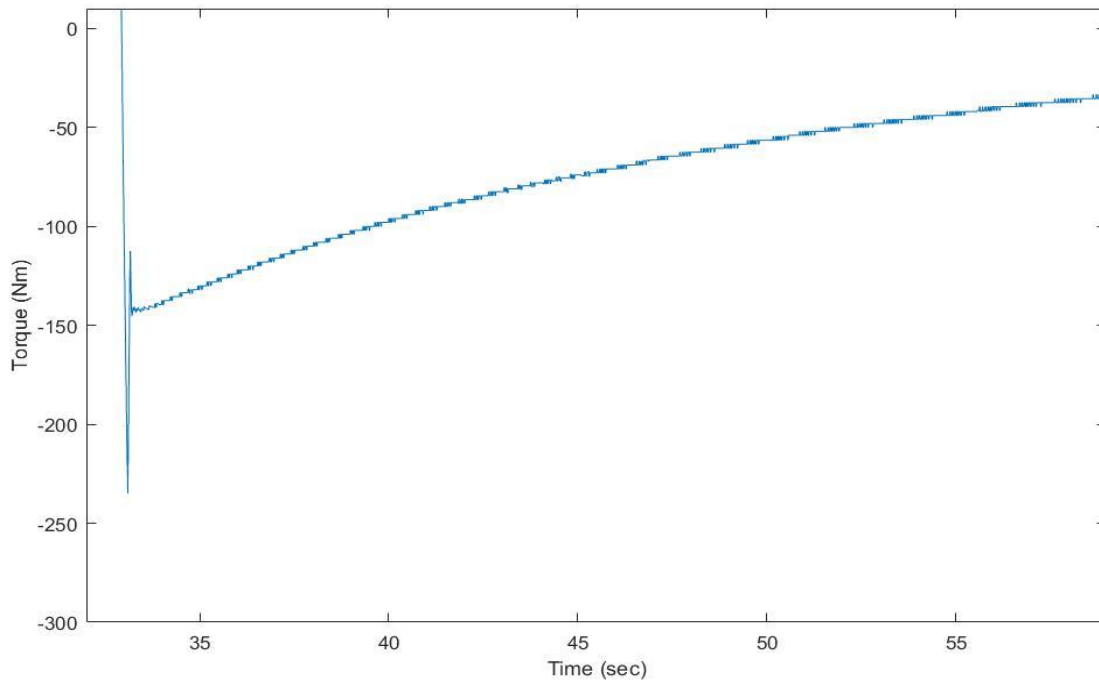


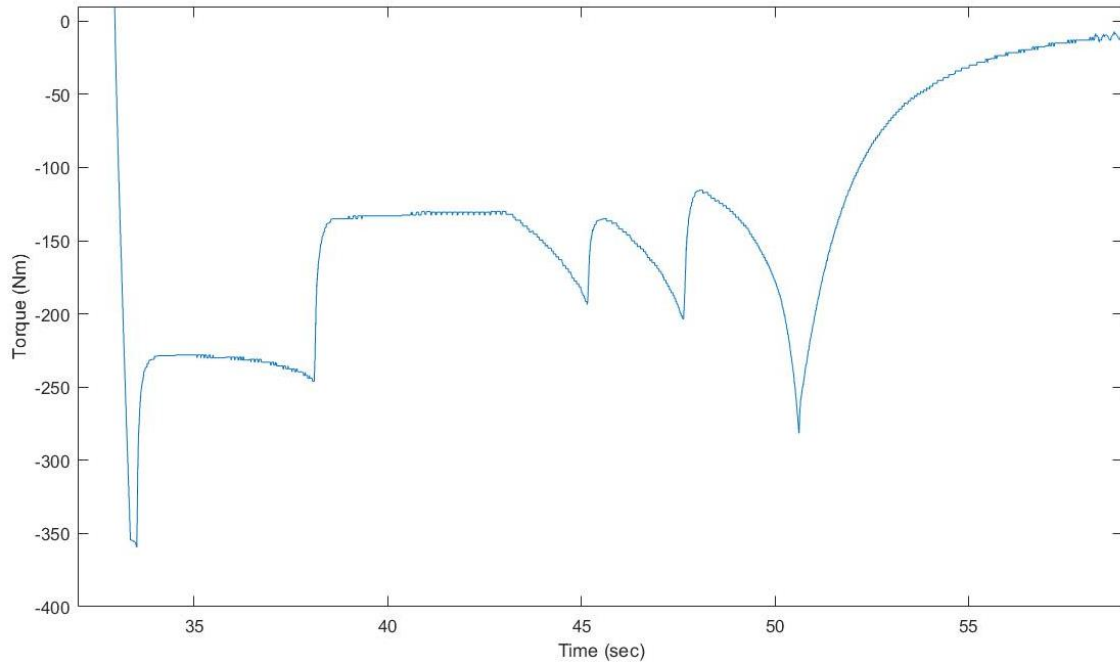
Figure 34: The figure on the left shows the velocity obtained with shift logic and the figure on the right shows without the shift logic

The graphs show that car only slows to 85 kph without a shift logic because the car isn't downshifting and keeping the motors in a high enough rpm range. The shift logic not only effects the speed obtained, but the current and the torque generated. The figures below show a torque comparison of the two regenerative brake methods.



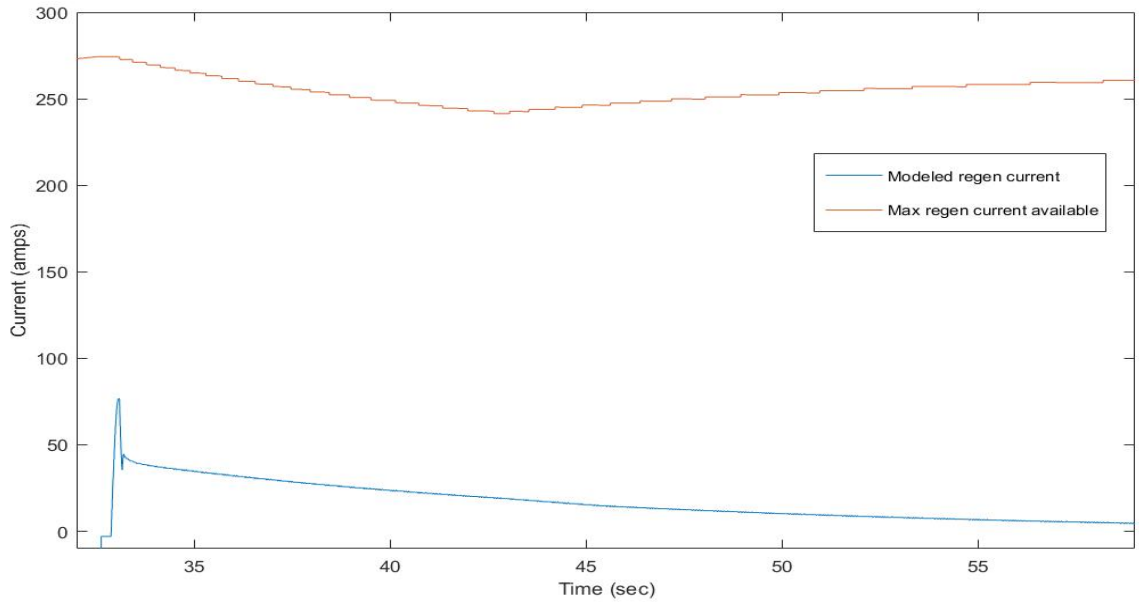
**Figure 35: Motor torque generated without a custom shift logic.**



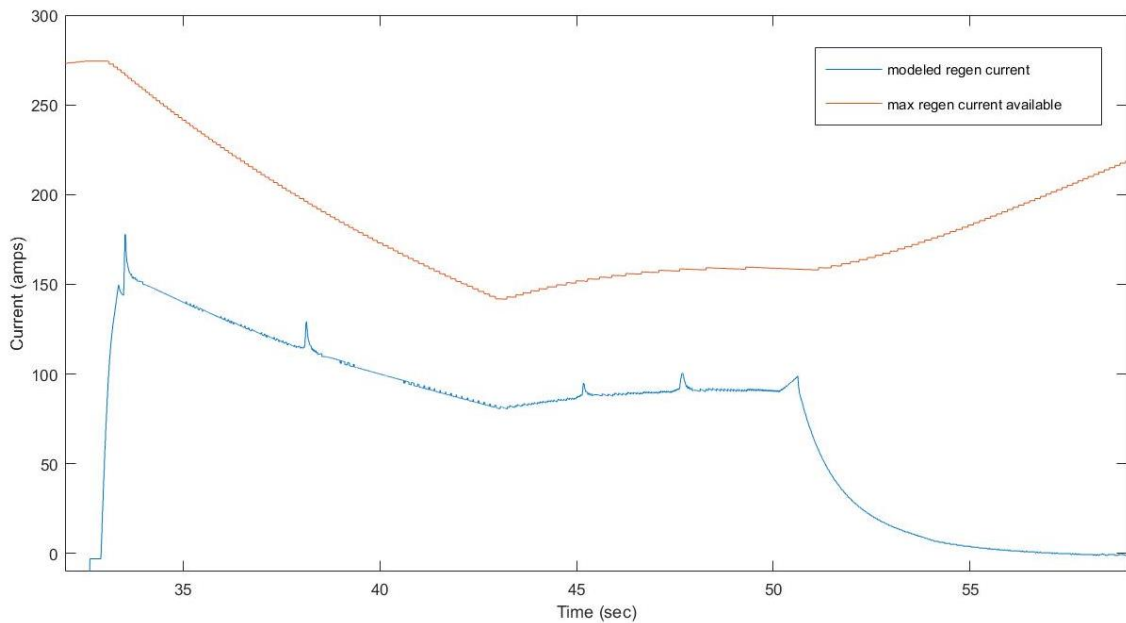


**Figure 36: Motor torque generated with custom shift logic**

The figures show that the regenerative braking with a custom shift logic generates a max torque 350 Nm, which is over 100 Nm greater than the regen without the shift logic. Also the custom shift logic maintains torque greater than 150 Nm until the regen controller fades out regen. The regen with standard shifting decreases steadily from 150 Nm to 50 Nm, which is far less torque than the custom logic. A decrease in torque correlates to current generated by the motors. The graphs below show a comparison between the current generated by the two methods.



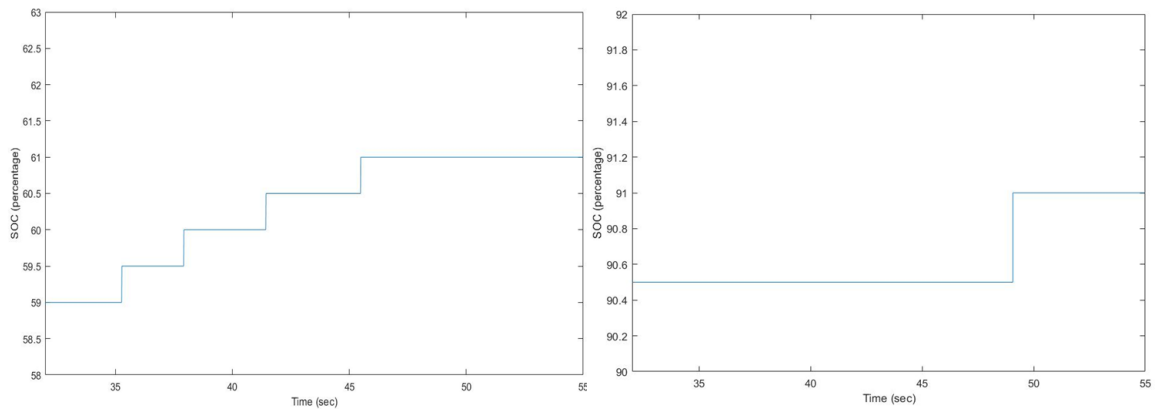
**Figure 37: Regenerative braking current with standard shift logic**



**Figure 38: Current generated with a custom shift logic.**

The figures show that the custom shift logic generated a max current of 200 amps, which is twice the max of the other shift schedule. Also, the custom shift logic maintains a current greater than 100 amps throughout the duration of the deceleration event. The normal shift logic generates less than 50 amps throughout the deceleration event. Due to

the lack in current generated with the standard shift logic, there was only a small gain in SOC.

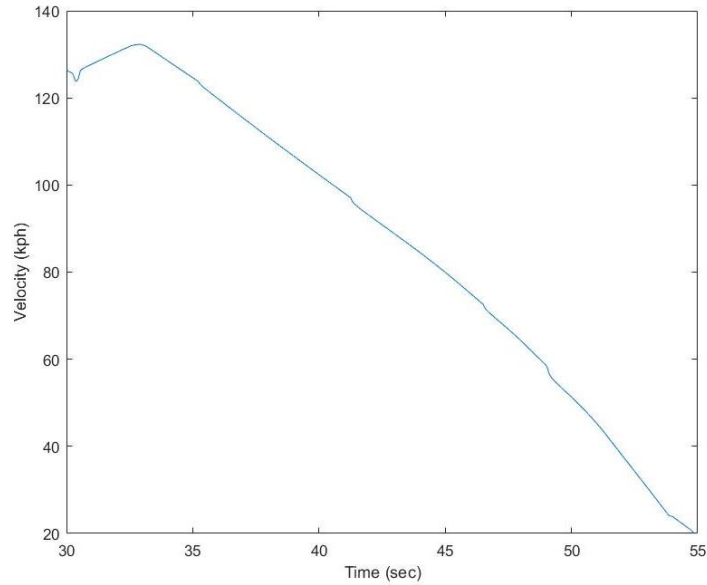


**Figure 39: The left figure shows the 2% gain in SOC from the custom shift logic and the right shows the .5% gain in SOC with standard shift logic**

The figures shown of the two shift logics make it evident that a custom shift map needed to be created to get the most efficiency from regenerative braking. The shift logic could be further tuned to get even better results.

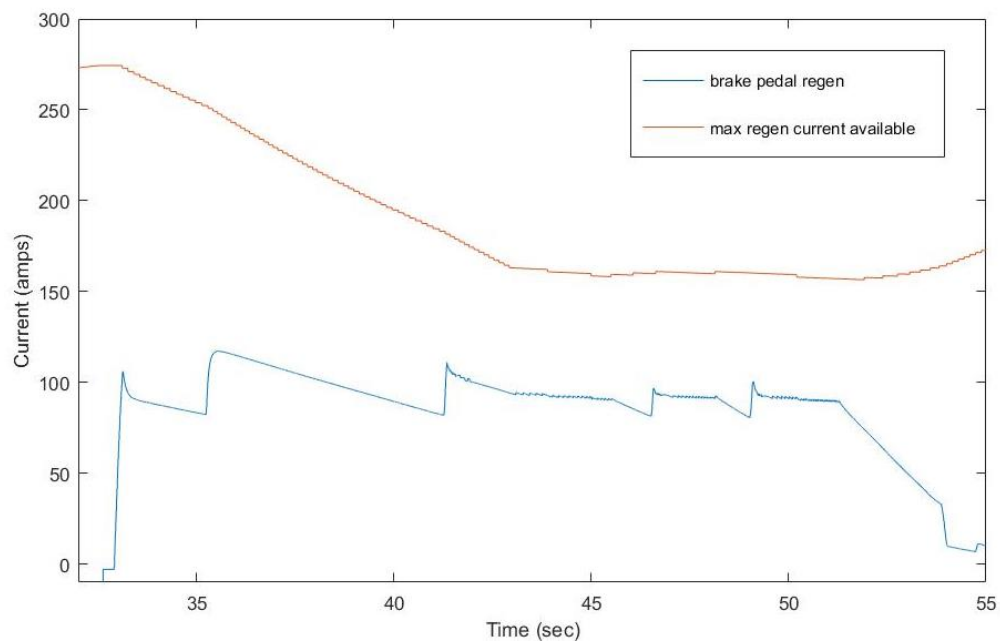
### Fusion Hydraulic and Regenerative Brake Pedal

Regenerative braking was also applied to the brake pedal to recover energy during heavy braking situations. The same accelerator pedal from previous testing used and 40% braking was applied when the accelerator pedal was released. This produced the velocity curve shown below.

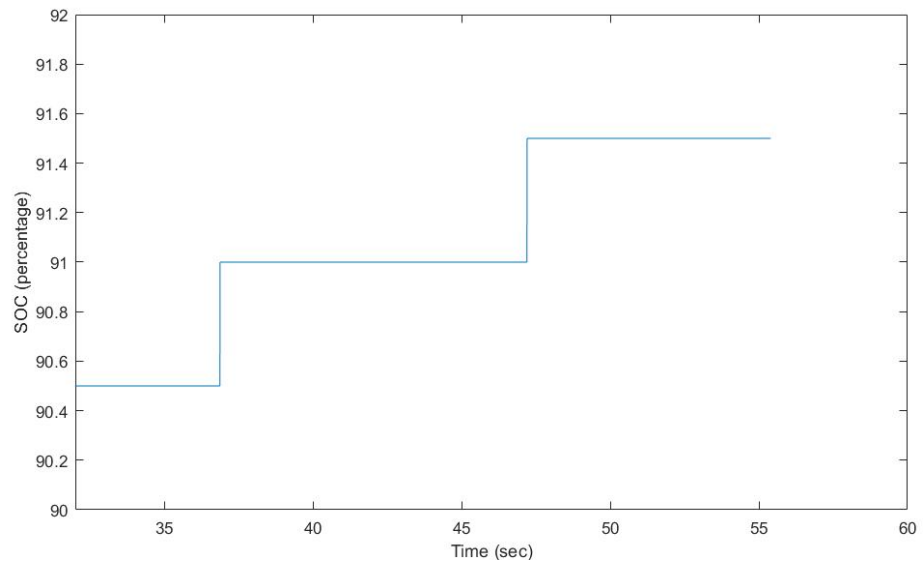


**Figure 40: Regenerative braking from 130 kph to 20 kph using brake pedal**

The brake pedal regen effectively brings the vehicle to low speed and generates a significant amount of current during that deceleration event. The current generated during this braking event caused a 1% increase in SOC, which is quite significant for one deceleration.



**Figure 41: Current generated during brake pedal regenerative braking**



**Figure 42: SOC increase during the braking event**

## Chapter V

### Conclusions, and Future Work

#### Conclusions

By developing a full car model that is comprised of a powertrain model, controller and six-degree of freedom vehicle dynamics model, a regenerative braking controller was able to be developed and tested on the Embry-Riddle's Camaro. The regenerative brake controller uses two different methods to recover energy during deceleration.

One of the methods used for regenerative braking was creating a floating pedal regen system, which works by remapping the pedal to produce a negative pedal position that correlates to a negative torque. This was accomplished using a dynamic lookup and changing the zero point of throttle using the correlation between speed and wheel torque. The new zero point is determined by running the current vehicle speed through a tanh controller and multiplying by a negative gain and sending the value to the lookup table. Once the regen torque is determined from the new pedal position, the torque is limited based on regen torque available, current SOC, and motor rpm. The torque requested is also sent through a rate limiter to control the rate of torque change and provide the driver with a comfortable deceleration rate.

The floating pedal regenerative braking also utilizes a custom shift map designed around the motor rpms and efficiencies. The custom shift logic utilizes the 8-speed automatic transmission to keep the motors in their peak efficiency regions, which is between 4000 rpm and 2000 rpm.

The other method used was regenerative braking through the brake pedal. This controller uses brake pedal position and correlates it to a negative regen torque. Also when the brake pedal is depressed, the floating pedal regen is canceled out and the car

only regens off the brake pedal to provide a comfortable deceleration rate. The regen braking will be disabled if the SOC is above 95%, ABS is active, regen disable button is depressed, or if the car is in any other gear than drive.

Overall the regenerative braking controller worked effectively with the automatic transmission in increasing the efficiency of the vehicle. In one 120 kph to 15 kph deceleration the vehicle gained to 2% SOC. The results show that an effective regenerative brake controller was developed for a rear-wheel drive parallel-series plug-in hybrid electric vehicle with an 8-speed automatic transmission.

### Future Work

If time permitted there are a few topics that would be recommended for further investigation.

One topic for further investigation would be regenerative brake shift logic, which is currently based purely on rpm and whether or not the rpm is decreasing or increasing. It would be interesting to look at the rate of change of rpm and determine if the shift needs to happen sooner to hit the rpm range and not overshoot the value. Based on some of the results, there is a quick drop in rpm at the initial let off of the pedal. This generally leads to a slight overshoot that could be compensated for by looking at the rate.

Another topic would be a mode based regenerative braking controller, where the method of regen and amount of regen would vary depending the selected mode of the vehicle. Currently the regenerative braking is built around using both the motors and the engine is running. Having the engine running means the regenerative braking must be cut off at 850 rpm, so the engine doesn't stall. If the car was in all electric mode, the regenerative braking could work all the way to 450 rpm, which is where the transmission is no longer spinning fast enough to work. Also there is a possibility to disable floating

pedal regen when the car is in sports mode and only use regen on the brake pedal to increase the braking performance of the vehicle.

A final topic for further investigation would be regenerative brake control based on dynamic vehicle parameters, such as yaw rate and wheel slip. The current controller works well in straight line regen, but some analysis needs to be done on the effects regen has on vehicle stability during cornering. Since the test vehicle for this controller is rear-wheel drive excessive rear braking will certainly cause instability. A controller that utilized weight transfer, yaw rates, and wheel slip could vary the amount of regen based on a range of acceptable values for these parameters. This is definitely a topic that must be investigated because the stability of the vehicle must not be compromised to gain some efficiency.



## Appendix A

### Bibliography

- [1] D. Christopher, "Electric Vehicle Sales Growing Fast," 2014.
- [2] C. o. T. t. A. V. a. Fuels, *Transitions to Alternative Vehicles and Fuels*, Washington D.C.: The National Academic Press, 2013.
- [3] Q. S. Shi, X. Zhang and F. Chen, "Multi-Lookup Table Based Regenerative Braking Strategy of Plug-In Hybrid Electric Vehicle," *Applied Mechanics and Materials*, pp. 44-47, 2010.
- [4] L. Cai and X. Chang, "Study on the Control Strategy of Hybrid Electric Vehicle Regenerative Braking," *Electronic and Mechanical Engineering and Information Technology(EMEIT)*, pp. 253-256, 2011.
- [5] P. Falcone, S. Pakazad and S. Solyom, "Predictive Approaches to Rear Axle Regenerative Braking Control in Hybrid Vehicles," *Decision Control*, pp. 7627-7632, 2009.
- [6] J. Han and Y. Park, "Cooperative regenerative braking control for front-wheel-drive hybrid electric vehicle based on adaptive regenerative brake torque optimization using under-steer index," *International Journal of Automotive Technology*, pp. 989-1000, 2014.
- [7] D. Peng, Y. Zhang, C. Yin and J. Zhang, "Combined Control of Regenerative Braking and Anti-Lock Braking System for Hybrid Electric Vehicles," *International Journal of Automotive Technology*, pp. 749-757, 2008.
- [8] F. Wang and B. Zhuo, "Regenerative Braking Strategy for Hybrid Electric Vehicles Based on Regenerative Braking Torque Optimization Control," *Proceedings of the Institution of Mechanical Engineers*, pp. 499-513, 2008.
- [9] J. Ko, S. Ko, H. Son, B. Yoo, J. Cheon and H. Kim, "Development of Brake System and Regenerative Braking Cooperative Control Algorithm for Automatic Transmission-Based Hybrid Electric Vehicles," *IEEE Transactions of Vehicular Technology*, pp. 431-440, 2015.
- [10] S. DeMers, "Mechanical and Regenerative Braking Integration for a Hybrid Electric Vehicle," 2008.
- [11] J. Ahn, K. Jung, D. Kim, H. Jin, H. Kim and S. Hwang, "Analysis of a regenerative braking system for hybrid electric vehicles using an electro-mechanical brake," *International Journal of Automotive Technology*, pp. 229-234, 2009.
- [12] Y. Yang, J. Zou, Y. Yang and D. Qin, "Design and Simulation of Pressure Coordinated Control System for Hybrid Vehicle Regenerative Braking System," *Journal of Dynamic Systems, Measurement, and Control*, vol. 136, 2014.
- [13] W. Parbowo and A. Purwadi, "Regenerative Braking Performance Analysis on GANG CAR Electric," Indonesia, 2013.
- [14] Z. Ding, D. Zhao and J. Zuo, "Modeling and Simulation about an Electric Car's Regenerative Braking System," in *International Conference on Mechatronics and Automation*, Harbin, 2007.

- [15] M. Yoong, Y. Gan, G. Gan, C. Leong, Z. Phuan and B. C. K. Chew, "Studies of Regenerative Braking in Electric Vehicle," in *Conference on Sustainable Utilization and Development in Engineering and Technology*, Kuala Lumpur, 2010.
- [16] S. Jansen, J. van Boekel, v. I. S.S., I. Bessellink and H. Nijmeijer, "Vehicle State Estimator based regenerative braking implementation on an electric vehicle to improve lateral vehicle stability," in *International Battery, Hybrid and Fuel Cell Electric Vehicle Symposium*, Barcelona, 2013.
- [17] C. Sankavaram, B. Pattipati, K. Pattipati, Y. Zhang and M. Howell, "Fault Diagnosis in Hybrid Electric Vehicle Regenerative Braking System," *IEEE Access*, pp. 1225-1239, 2014.
- [18] Y. Gao, L. Chen and M. Ehsani, "Investigation of the Effectiveness of Regenerative Braking for EV and HEV," *SAE International*, 1999.
- [19] H. yeo and H. Kim, "Hardware-in-the-loop simulation of regenerative braking for a hybrid electric vehicle," *Journal of Automobile Engineering*, vol. 216, 2002.
- [20] G. Yin and X. Jin, "Cooperative Control of Regenerative Braking and Antilock Braking for a Hybrid Electric Vehicle," *Mathematical Problems in Engineering*, vol. 2013, 2013.
- [21] L. Li, L. Xujian, W. Xiangyu, S. Jian, H. Kai and L. Chenfeng, "Analysis of downshift's improvement to energy efficiency of an electric vehicle during regenerative braking," *Applied Energy*, vol. 176, pp. 125-137, 2016.
- [22] L. Chen, Z. Junsui, L. Yutong and Y. Yuan, "Novel control algorithm of braking energy regeneration system for an electric vehicle during safety-critical driving maneuvers," *Energy Conversion and Management*, vol. 106, pp. 520-529, 2015.
- [23] C. Jo, J. Ko, H. Yeo, T. Yeo, S. Hwang and H. Kim, "Cooperative regenerative braking control algorithm for an automatic-transmission-based hybrid electric vehicle during a downshift," *Proc Inst Mech Eng Part D J Automob Eng*, vol. 226, pp. 457-467, 2012.
- [24] C. Lv, J. Zhang and Y. Li, "Mechanism analysis and evaluation methodology of regenerative braking contribution to energy efficiency improvement of electrified vehicles," *Energy Conversion and Management*, pp. 469-482, 23 November 2014.
- [25] J. Zhang, C. Lv, J. Gou and D. Kong, "Cooperative control of regenerative braking and hydraulic braking of an electrified passenger car," *Journal of Automobile Engineering*, vol. 226, no. 10, pp. 1289-1302, 2012.
- [26] J. Z., Y. L. and C. L., "New regenerative braking control strategy for rear-driven electrified minivans," *Energy Conversion and Management*, pp. 135-145, 26 March 2013.
- [27] H. Pacejka and E. Bakker, "The magic formula tyre model," *Vehicle System Dynamics*, vol. 21, no. 1, pp. 1-18, 1992.
- [28] P.-I. Reif, *Automotive Handbook*, Plochingen: Robert Bosch GmbH, 2011.

