

# EMBRY-RIDDLE

## Aeronautical University™

### SCHOLARLY COMMONS

---

Dissertations and Theses

---

Fall 2011

## State of the Art of Piloted Electric Airplanes, NASA's Centennial Challenge Data and Fundamental Design Implications

Lori Anne Costello

*Embry-Riddle Aeronautical University - Daytona Beach*

Follow this and additional works at: <https://commons.erau.edu/edt>



Part of the [Aerospace Engineering Commons](#)

---

### Scholarly Commons Citation

Costello, Lori Anne, "State of the Art of Piloted Electric Airplanes, NASA's Centennial Challenge Data and Fundamental Design Implications" (2011). *Dissertations and Theses*. 37.

<https://commons.erau.edu/edt/37>

This Thesis - Open Access is brought to you for free and open access by Scholarly Commons. It has been accepted for inclusion in Dissertations and Theses by an authorized administrator of Scholarly Commons. For more information, please contact [commons@erau.edu](mailto:commons@erau.edu).

STATE OF THE ART OF PILOTED ELECTRIC AIRPLANES, NASA'S CENTENNIAL CHALLENGE DATA AND  
FUNDAMENTAL DESIGN IMPLICATIONS

by

Lori Anne Costello

A Thesis Submitted to the  
Graduate Studies Office  
in Partial Fulfillment of the Requirements for the  
Degree of Master of Science in Aerospace Engineering

Embry-Riddle Aeronautical University  
Daytona Beach, Florida  
Fall 2011

Copyright by Lori Anne Costello 2011

All Rights Reserved

STATE OF THE ART OF PILOTED ELECTRIC AIRPLANES, NASA'S CENTENNIAL CHALLENGE DATA AND  
FUNDAMENTAL DESIGN IMPLICATIONS

by

Lori Anne Costello

This thesis was prepared under the direction of the candidate's thesis committee chairman, Dr. Richard "Pat" Anderson, Department of Aerospace Engineering, and has been approved by the members of her thesis committee. It was submitted to the Department of Aerospace Engineering and was accepted in partial fulfillment of the requirements for the degree of Master of Science in Aerospace Engineering.

THESIS COMMITTEE:



Dr. Richard "Pat" Anderson  
Chairman



Dr. Albert D. Helfrick  
Member



Professor Charles Eastlake  
Member

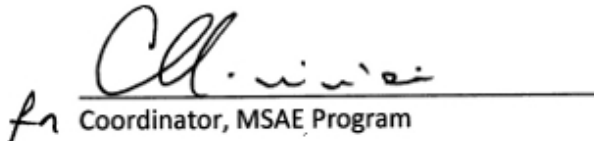

Coordinator, MSAE Program



Department Chair, Aerospace Engineering

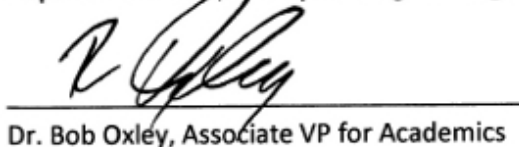

Dr. Bob Oxley, Associate VP for Academics

Date

12/20/2011  
Date

## ACKNOWLEDGEMENTS

This thesis is the culmination of two years of work on the Green Flight Challenge Eco-Eagle. The Eco-Eagle and this thesis would not have been possible without countless help and inspiration from friends and family.

I would like to thank Dr. Anderson for giving me the opportunity to participate in Embry-Riddle's Green Flight Challenge Team and for supporting me and the Eco-Eagle project. Without his guidance I would not have this paper and understood as much as I now do about electric airplanes. He gave me the opportunity to be a part of a field of aviation that I have dreamed of participating in and would not have had the ability to without him. I would also like to thank Dr. Helfrick and Professor Eastlake for being members of my thesis committee. Both spent many hours with me and this paper would not have been possible without their help. Thank you to Hever Moncayo for fixing my equations so that I came up with reasonable solutions.

I would also like to thank Mikhael Ponso for risking his life to fly the Eco-Eagle, for all of his input, his time in making this plane fly, his taste in music on the trip to and from California, and for the advice and knowledge that he added. A large thank you to Professor Greiner for working very hard on the Eco-Eagle, devoting weekends and late nights to helping the plane fly, and for giving us the confidence and motivation that we needed to be successful. To Dr. Liu for giving us a real working electrical system; without his system our plane would not be the first hybrid parallel gas/electric airplane in the world. Among many others I would also like to thank Kim Smith for all of her help on the Eco-Eagle, for her hard work and motivation, and for keeping me sane. Without Kim the plane would not have made it to the competition. To Shirley Koelker for all of her help in ordering parts, supporting the entire project and being such a great friend. Thank you to Craig Millard, Donovan Curry, Cyrus Jou, Matt Gonitzke, Hitesh Patel, Prateek Jain, and Ankit Nanda for all of their hard work on the Eco-Eagle and making it a success.

I would also like to thank all of my friends and family for all of their support along the way. Thank you to my brother Michael for always listening to my long winded stories even if he wasn't paying attention. To Cari for always being supportive and giving me good advice in any occasion. To Coach Hopfe for standing by me and supporting me in all of my decisions and endeavors. Thank you Amanda and Caroline for being such wonderful roommates and always being there to listen and make me laugh. To Stephanie for dragging me away sometimes to dinner or for walks and giving me great advice. Thank you Kira for taking me sailing and including me in team events even when I wasn't on the team any more. Thanks to all of my track teammates and friends over the years and to my ESA friends for being so supportive; every one of you helped in your own way to get me to where I am. Most of all I would like to thank my parents and my grandmother, without their help and support I would not be where I am today having accomplished what I have. You always believed in me and never thought differently, thank you.

## ABSTRACT

Author: Lori Anne Costello

Title: STATE OF THE ART OF PILOTED ELECTRIC AIRPLANES, NASA'S CENTENNIAL CHALLENGE DATA AND FUNDAMENTAL DESIGN IMPLICATIONS

Institution: Embry-Riddle Aeronautical University

Degree: Master of Science in Aerospace Engineering

Year: 2011

The purpose of this study was to determine the current state of the electric airplane as primarily defined by results from NASA's Green Flight Challenge Competition. New equations must be derived in order to determine the endurance and range for electric airplanes since the standard equations depend upon weight change over a flight and the weight of an electric airplane does not change. These new equations could then be solved for the optimal velocity and altitude which were the two driving factors that could change range and endurance for a given airplane configuration. The best velocity for range and endurance is not a function of energy storage or weight change thus the results turn out to be very similar to internal combustion engine airplanes, however, the optimal altitude for the best range and endurance equates to flying as high as reasonably possible. From examining the Green Flight Challenge data of the two fully electric airplanes, the analysis suggests that the electric propulsion system is not the only measure, given today's battery technology, that helps create a viable electric airplane solution. Aerodynamic efficiency becomes very important in order to reduce the required amount of energy. Airplanes that are aerodynamically inefficient make bad electric airplanes because the energy density of batteries is still low and the energy available to carry on board is limited. The more energy wasted on drag, the less the range and endurance of the airplane can be since the addition of more batteries may not be an option.

# Contents

Table of Figures .....	7
LIST OF ABBREVIATIONS .....	8
GLOSSARY OF TERMS.....	9
Chapter 1.....	10
1.1 Introduction and Problem Statement.....	10
1.2 Review of Literature.....	12
1.2.1 Manned General Aviation Electric Prototypes.....	12
1.2.2 UAV's.....	16
1.2.2.1 High Altitude Technology Demonstrators .....	17
1.2.3 Batteries .....	18
1.2.4 Electric Motors.....	21
1.2.5 Electric Architectures .....	23
1.2.6 Hybrid Gas/Electric Architectures.....	24
1.2.7 Green Flight Challenge .....	26
Chapter 2: Theory .....	34
2.1 Derivation of Classical Range and Endurance Equations for Electric Propulsion .....	34
2.1.1 Electric Airplane Flight Profile Eqn. Derivation: Range .....	34
2.1.2 Electric Airplane Flight Profile Eqn. Derivation: Endurance.....	41
2.2 Derivation of Energy and Efficiency Equations for Electric and Electric Hybrid Airplanes .....	47
2.3 Equations Required for Comparing Electric Airplanes to Reciprocating Engine Airplanes.....	49
Chapter 3 Analysis and Results .....	54
3.2 The Current State of the Electric Airplane .....	58
Chapter 4 Conclusion .....	75
References .....	79

## Table of Figures

Figure 1: Energy Volume Density vs. Energy Density for various sources of energy <sup>22</sup> .....	10
Figure 2: Energy Density for Various Fuels <sup>22</sup> .....	11
Figure 3: Specific Energy for Various Fuels <sup>22</sup> .....	12
Figure 4: Unit Weight vs. Energy Density for various batteries <sup>(15, 26,36, 46, 59, 69)</sup> .....	19
Figure 5: Eco-Eagle Propulsion System .....	24
Figure 6: Siemens, AEDS, and Diamonds Series Gas/Electric Hybrid Propulsion System <sup>74</sup> .....	26
Figure 7: 3-View Drawing of the Eco-Eagle <sup>64</sup> .....	29
Figure 8: 3-View Drawing of the Phoenix Airplane <sup>55</sup> .....	30
Figure 9: Pipistrel G4 3-View Drawing .....	32
Figure 10: EGenius 2-View Drawing .....	33
Figure 11: Speed Polar for Unmodified Stemme S10 Clean Configuration <sup>64</sup> .....	50
Figure 12: Rate of Climb vs Velocity for Clean and Dirty case of the Original Configuration of the Stemme S10.....	52
Figure 13: Speed Polar Shifted due to Weight change <sup>64</sup> .....	60
Figure 14: Weight vs. L/D and the Required Power .....	61
Figure 15: Weight vs. L/D for various power settings while climbing at 444 fpm .....	62
Figure 16: Weight vs. Propulsive Efficiency and the Required L/D.....	64
Figure 17: The flow of electricity from the outlet on the far left all the way to the propeller on the far right with efficiencies included .....	65
Figure 18: Drag vs. Velocity for the Unmodified Stemme S10 for 'clean' and 'dirty' flight operations.....	69
Figure 19: Power Available and Power Required for the 'clean' and 'dirty' conditions of the unmodified Stemme S10 motor-glider .....	70
Figure 20: Average Power Cruising vs. Distance for Various Energy Requirements (at 86 knots).....	72



## LIST OF ABBREVIATIONS

CAFE	Comparative Aircraft Flight Efficiency
FAA	Federal Aviation Administration
GFC	Green Flight Challenge
R/C	Rate of Climb
kts	knots
$V_{ne}$	Never Exceed Speed
L/D	Lift to Drag
mpg	miles per gallon
mph	miles per hour
POH	Pilot's Operating Handbook
BTU	British Thermal Unit

## GLOSSARY OF TERMS

R	= Range (feet)
$R_e$	= Range of electric airplane (feet)
$\eta_p$	= Propeller efficiency (%)
L	= Lift (pounds)
D	= Drag (pounds)
W	= Weight (pounds)
T	= Endurance (sec)
$\rho_o$	= Air density at sea level (slugs/ft <sup>3</sup> )
S	= Wing plan-form area (feet <sup>2</sup> )
$C_L$	= Coefficient of lift
$C_D$	= Coefficient of drag
v	= Velocity (feet/second)
t	= Time (sec)
$\rho$	= Air density (slugs/ft <sup>3</sup> )
P	= Power (lbft/sec)
$E_T$	= Total energy stored aboard airplane (Watt-hrs)
E	= Total energy for GFC competition (HP-hr)
h	= Altitude (feet MSL)
$C_{D_o}$	= Coefficient of drag for zero lift
A	= Aspect Ratio
e	= Oswald's efficiency
b	= Wing span (feet)
T	= Thrust (pounds)
$C_p$	= Coefficient of power
$C_T$	= Coefficient of thrust
J	= Advance ratio
n	= Number of propeller blades
d	= Diameter of propeller (feet)
$HP_{ave}$	= Average horse power over the flight profile (HP)
$\eta_m$	= Motor efficiency (%)
$HP_{req}$	= Required horse power (HP)
$P_{avail}$	= Power available (pounds)

# Chapter 1

## 1.1 Introduction and Problem Statement

Embry Riddle Aeronautical University investigated alternative methods of propulsion for aircraft. The Eagle Flight Research Center, a facility owned and run by the University, investigated into several alternative propulsion schemes for aircraft including diesel engines, rotary engines, alternative liquid fuels (Swift), and most recently, electric propulsion and electric hybrid propulsion. All of these projects were researched in order to minimize the impact of aviation on the environment, public health, and energy consumption. In addition, a goal of the University was to strive towards environmentally conscious and sustainable energy sources for its aviation endeavors. This thesis will focus on the hybrid electric and electric propulsion that is feasible with current technology and will leverage the data yielded during NASA's Green Flight Challenge to define the current state of the art of electric propulsion for aircraft.

As the world moves away from fossil fuels there are numerous sources of energy that must be considered. In considering alternative forms of energy, various figures must be considered with the primary being energy density. The following is a chart of energy densities of most known energy sources.

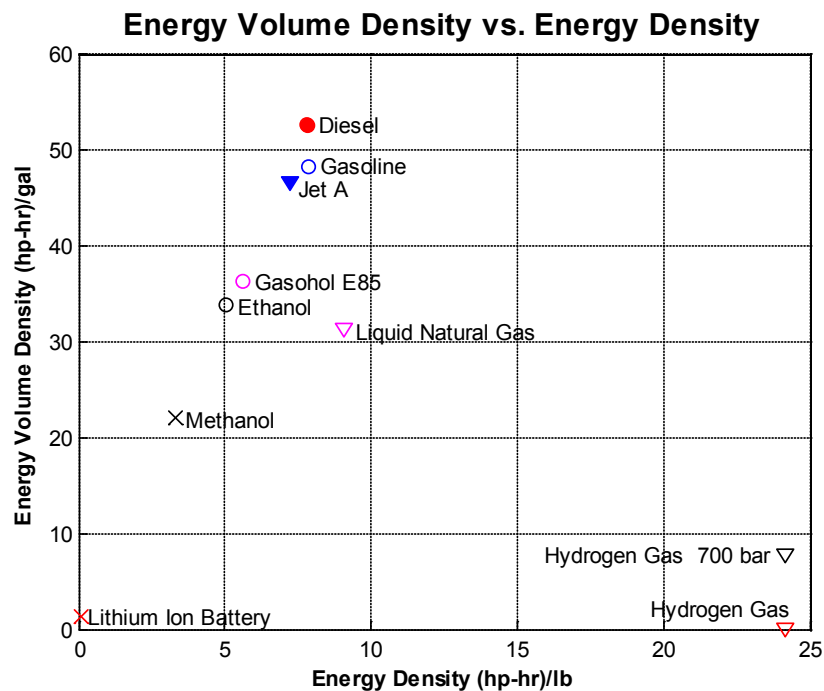

Figure 1: Energy Volume Density vs. Energy Density for various sources of energy<sup>22</sup>

Figure 1 shows many of the conventional forms of storing energy. Gasoline is an excellent method of storing energy as this figure demonstrates. In looking for alternative forms of energy storage Natural Gas, Diesel, and battery storage among others are the most applicable to aircraft propulsion. The focus of this thesis is on electric battery technology thus the primary focus is on the use of batteries as energy storage in an aviation application. Battery energy density is not a fixed value but one which increases with time as technology progresses. Figure 2 compares Lithium-Ion batteries to various fuels in terms of energy density. Diesel, Gasoline and Jet A are all fuel sources that are difficult to let go of as continue fuel sources because of their high energy density especially since space can be a large concern on airplanes.

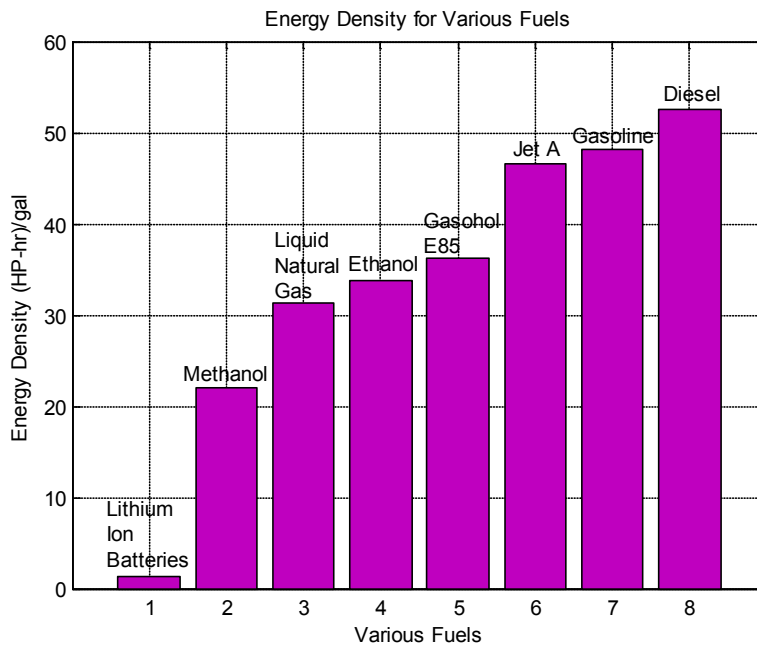

Figure 2: Energy Density for Various Fuels<sup>22</sup>

Different chemistries continue to surface which lead to different specific energies. Figure 3 depicts different fuels and their different specific energies. From this figure it is simple to see why fuels like Gasoline, Diesel and Jet A are difficult to let go. In terms of energy per weight items with high specific energy cannot be beat.

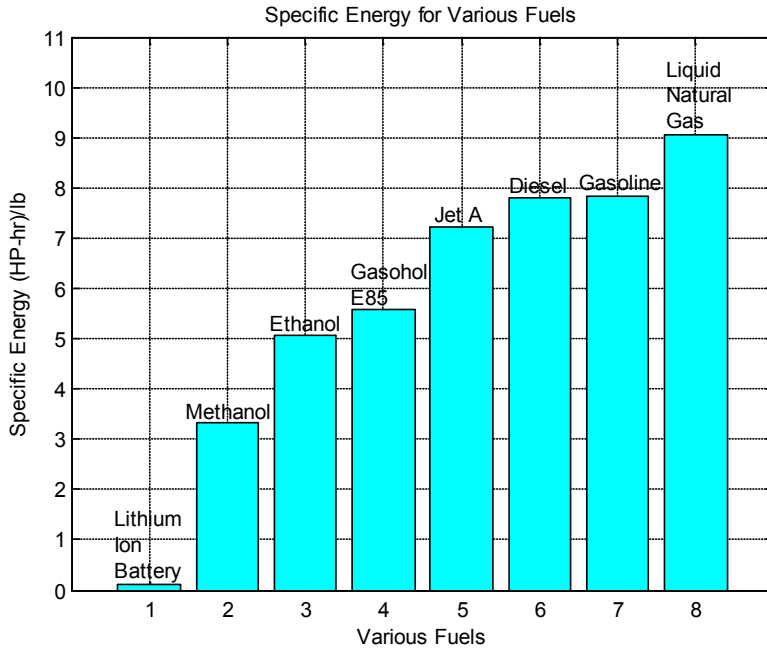

Figure 3: Specific Energy for Various Fuels<sup>22</sup>

Note that there is a significant difference between Lithium-Ion batteries and the other fuels listed. All of the fuels listed, except for Lithium-Ion batteries are consumable and used in the production of power whereas Lithium-Ion batteries act as storage devices and are refilled after each use.

Therefore, the aircraft discussed here are technology demonstrators that are in their infancies and will grow as battery energy density increases with time. Right now, the energy density of a battery compared to that of gas is nearly a factor of 80. This paper describes the flight profile for an electric airplane and helps determine the current state of fully electric propulsion for general aviation applications.

## 1.2 Review of Literature

### 1.2.1 Manned General Aviation Electric Prototypes

Tissandier and Alberto Santos-Dumont were the first people to successfully power an airship with an electric motor in 1883<sup>25</sup>. Then in 1979, the Solar Rise became the first manned electric and solar powered airplane, almost 100 years after the first electrically powered aircraft<sup>70</sup>. This airplane was a proof of concept and showed that the solar/battery combination was a possibility for flight and the next avenue of research and development.

There were several other airplanes that experimented with the solar and battery power technology of the time, but batteries would not prove to be reasonable due to low battery energy density until 1998 when the AE-1 Silent made its first flight<sup>2</sup>. This was categorized as a self-launching sailplane which paved the way for self-launch sailplanes to begin a transition over to electric. In 1999 a new electric powered airplane entered the market, the Antares 20E motor glider<sup>33</sup>. In August of 2006, Lange Aviation received certification by EASA for their 20-meter wing spanned motor glider that used a 56 HP external brushless motor. This motor was powered by 72 cells of Lithium Ion Batteries manufactured by SAFT and were stored in the wings. The flight profile of the airplane allowed the motor-glider to climb up to almost 10,000 feet before the batteries would be exhausted. The main operation of the system was only to lift the glider to a high enough altitude where the motor could be turned off and normal gliding operations could then take place. This airplane was only designed to be a self launching glider and not a sustained flight propulsion system.

February of 2008 witnessed the World's first Hybrid fuel cell/battery powered airplane<sup>28</sup>. The airframe was a two seat Dimona motor-glider made by Diamond that was modified to house the batteries, fuel cells and one pilot. The airplane flew in Spain several times climbing up to 3300 feet under battery and fuel cell power and then switched over to only fuel cells for 20 minutes at an airspeed of 54 kts.

Then, in 2009, Yuneec, a radio control airplane company that revolutionized the market by installing electric motors onto small airplanes while making them affordable to the average person, revealed the first commercially available manned electrically powered airplane<sup>76</sup>. This airplane, the E430, was designed with high aspect ratio wings like the typical motor glider but with the battery endurance that would allow it to travel to a destination under electric power. The airplane cruised around at 52 kts, had a 54 HP motor, and carried 184 pounds of batteries that would give an endurance of two to two and half hours depending on airspeed<sup>76</sup>.

Table 1: History of Electric Aircraft

First Flight	Aircraft	Propulsion Type	
1883	Airship	Batteries	 (25)
April 29, 1979	Solar Rise	Solar/Batteries	 (70)
June 13, 1979	Solar One	Solar/Batteries (NiCd)	 (17)
May 19, 1980	Gossamer Penguin and Solar Challenger	Solar/Batteries (NiCd)	 (18)
August 21, 1983	Solair 1	Solar/Batteries	 (48)
1990	Sunseeker	Solar/Batteries (NiCd)	 (41)
1996	Icare II	Solar/Batteries (Lipo)	 (30)
1998	Silent AE-1	Batteries	 (2)
2003	Antares 20E	Batteries (Li-Ion)	 (34)
July 2006	Dry-Cell Plane	Batteries (AA Dry Cell)	 (10)

April 2007	ElectraFlyer	Batteries (Lipo)	 (72)
December 2007	APAME	Batteries (Lipo)	 (53)
2007	Sky Spark	Batteries (Lipo)	 (28)
February 2008	Boeing-Fuel Cell Demonstrator	Hydrogen Fuel Cell/Batteries	 (28)
June 4, 2008	ElectraFlyerC	Batteries (Li-Ion)	 (21)
July 9, 2009	Antares DLR-H2	Hydrogen Fuel Cells	 (9)
July 2009	Flightstar e-Spyder	Batteries (Lipo)	 (23)
December 3, 2009	Solar Impulse	Solar/Batteries	 (51)
2009	Yuneec e430	Batteries (Lipo)	 (76)
June 2010	EADS Cri-Cri	Batteries	 (28)
3 December 2010	Sonex	Batteries (Lipo)	 (20)
February 2011	Pipistrel Taurus Electro G2	Batteries (Lipo)	 (25)
February 2011	Silent 2	Batteries	 (38)





March 2011	PC Aero- Electra One	Batteries (Lipo)	 (52)
August 2011	MC30 Firefly	Batteries	 (39)
2011	Lazair	Batteries	 (61)

Table 1 shows the history of electric flight involving manned missions. This table includes solar, battery, and fuel cell powered airplanes and various combinations of the two. The first manned electrically powered airplanes appeared in the 1970's as technology demonstrators but it was not until the middle to late 1990's that electric airplanes began to become more feasible. The Icare in 1998 became the first fully electric manned powered airplane which demonstrated that battery energy density was increasing<sup>30</sup>. Over the next 13 years most of the airplanes listed flew under battery power alone not needing the extra solar power and flew missions longer than a few miles.

### 1.2.2 UAV's

Unmanned Aerial Vehicles (UAV's) were the first airplanes to take to the skies powered by electricity. While the first UAV was flown in 1917 by Andrew Lowe, the first electrically powered airplane did not fly until many years later<sup>48</sup>. It was not until 1957 in the United Kingdom, that Colonel H. J. Taplin made the first electric powered radio controlled flight of an airplane<sup>48</sup>. His airplane, the Radio Queen, used 28 zinc/silver batteries weighing in at 28 ounces which supplied 8 amps and 30 volts to a 30 ounce electric motor to propel his airplane. Since the Radio Queen, electric powered radio controlled airplanes are now a dominating and ruling market amongst the radio control pilots in the world.

In 1974, the Sunrise I airplane took to the skies as the first ever solar/battery powered airplane weighing only 27 pounds and flying to an altitude of 40 feet over a distance of half a mile<sup>48</sup>. This was a technology demonstrator for manned airplanes like the Sunrise and fed into other non-manned mission and projects like the NASA Pathfinder and Helios projects that pushed the level of battery and solar technology to high altitude long duration and endurance flights. QinetiQ's Zephyr airplane would come

around in 2006 and smash endurance records and set the most recent endurance record of 14 days and 24 minutes aloft<sup>57</sup>. The QinetiQ airplane did not need any sort of refueling and could continue cycling between batteries and fuel cells pushing efficiency, endurance and range to unimaginable levels in comparison to the gas powered engine airplanes.

*Table 2: History of Unmanned Electrically Powered Aerial Vehicles*







First Flight	Aircraft	Propulsion Type	
1957	Radio Queen	Batteries (Zinc/Silver)	 (48)
1974	Sunrise I	Solar	 (48)
1880	NASA Pathfinder and Helios	Solar/Batteries	 (42)
2005	Alan Cocconi	Solar/Batteries	 (63)
March 2006	QinetiQ Zephyr	Solar/Batteries (Li/S)	 (77)
29 January 2007	Aerovironment Puma	Fuel Cell/Batteries	 (33)

Table 2 shows several unmanned aerial vehicles that were primarily technology demonstrators to prove the concepts of electric and hybrid technology. These demonstrators were implemented onto manned flights and other forms of UAV's for various different missions. The endurance that is gained from the electric and solar powered systems could be useful in surveillance missions.

### 1.2.2.1 High Altitude Technology Demonstrators

The NASA Pathfinder and Helios were two projects that looked into high altitude and long duration flights of solar and battery powered airplanes. The Pathfinder airplane consisted of a wing body with solar panels along the top and six electric motors on the trailing edge<sup>50</sup>. Pathfinder flew several times and on July 7, 1997, the airplane flew to an altitude of 71,500 feet. The Pathfinder was then given wing

extension and two more motors which allowed it to fly up to 80,201 feet<sup>50</sup>. Using this technology the Helios was made that had even a longer wingspan and more motors and reached an altitude of 96,863 feet.

These three airplanes were all proof-of-concept airplanes that helped develop solar cell and battery technology and helped demonstrate several key benefits of electric motors. As altitude increases, unlike with internal combustion engines, the performance of the engine does not decrease. Since the electric motor is only affected by the friction on the propeller, the electric motor efficiency increases with altitude.

### **1.2.3 Batteries**

Airplanes have strict weight constraints that make batteries a difficult choice in order to provide high power for takeoff and continued power for endurance cruise operations. Alongside the weight increase there are several other important characteristics of batteries that must be considered including a sophisticated battery management system, treatment of the battery that can greatly reduce the life cycle of the battery, and the life cycle cost of the battery which includes disposal and recycling costs<sup>13</sup>.

Referring to Figure 1 regarding the specific energy of various energy sources including gasoline and kerosene (Jet A) which are used in conventional aircraft, and batteries, there is a large difference between the specific energy and the energy volume density between these traditional fuels and batteries. This difference means that batteries must be heavier and take up more space than gasoline and Jet A. Figure 1 only lists Lithium Ion batteries, however, there are many different types of batteries that can be used. Amongst these batteries are batteries with less weight per specific energy.

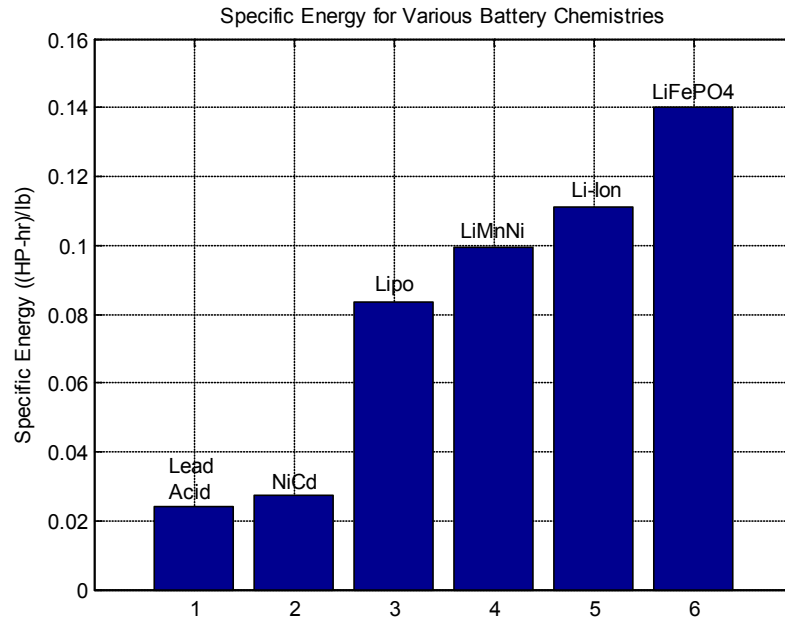

Figure 4: Unit Weight vs. Energy Density for various batteries <sup>(15, 26,36, 46, 59, 69)</sup>

Since weight is such an important value in airplane design Figure 4 compares weight to energy density of various batteries. This figure shows that Gel Cell and Lead Acid batteries are heavy but with low energy density. LiFePO<sub>4</sub> batteries have a high energy density with a low weight. Li-Ion, Lipo, and LiMnNi are all batteries with lower weight than LiFePO<sub>4</sub> however the energy density is a little bit lower for some. Of the listed batteries LiFeO<sub>4</sub> have the highest energy density and are relatively light compared to several other options. In the world of aviation design, weight is critical.

Modes of failure are another great concern. Back in 2006 Dell, Apple, Lenovo, and Toshiba all recalled several of their Lithium batteries they had sold to consumers that powered their laptops<sup>73</sup>. While these batteries were new and provided some of the highest levels of energy density of the time they were also melting, catching on fire and exploding during the recharging portion of operation. Lithium-ion batteries have been the cause of several airplane fires including a fire that caused a UPS airplane to crash in Dubai in 2010<sup>37</sup>. In this case the batteries were only being transported and were not even being charged, but if batteries can bring down an entire Boeing 747-400 in a matter of minutes they can surely cause trouble for a smaller general aviation airplane. If the temperature gets to high and goes above the glass-transition temperature of a composite airplane, then the resin will liquefy and structural failure can be a large concern. Therefore, battery temperature in airplanes is of great concern.

The FAA realized the safety hazard associated with battery usage on airplanes and have put out several Technical Standard Orders (TSO's) over the years regarding battery design and durability. These TSO's are designed to help increase safety of items that could be dangerous to the safety of an airplane if standards and regulations are not set in place. Companies who manufacture parts for airplanes that have TSO restrictions require a TSO authorization which both approves the design and the manufacturing process<sup>66</sup>. Recently, in 2006, the FAA released TSO-C179 that discusses the requirements for rechargeable lithium batteries to be used on board the airplane to power equipment (TSO-C179). In the document are listed several Minimum Performance Standards that discuss various tests that are required and the results that must be seen, such as no leaks, venting or fires.

Recharging lithium batteries requires a balancing system that monitors voltage, current, and temperature<sup>12</sup>. The primary reason for the monitoring system is because each battery cell is not the same and can degrade with time differently. With each charge and discharge the battery cells lose some of their energy capacity and as time progresses they no longer hold as long of a charge. Batteries left on shelves will degrade with time as well. As the batteries charge, current is sent through each battery cell and the voltage will build up. If not regulated the battery will surpass its maximum voltage and could be damaged. In conjunction with monitoring voltage, many balancers and management systems also monitor temperature, as the battery cell reaches its maximum charge the temperature of each cell begins to increase which can lead to reduced charge capacity and a potential thermal runaway. In order to ensure that overcharge does not occur each battery cell has a resistor in parallel with it; as the voltage reaches the maximum voltage for the cell the current is sent down the parallel resistor in order to bypass the battery cell. Since each battery cell is different, each cell reaches maximum charge at different times meaning that these resistors are used and that heat is produced. Temperature sensitivity of the immediate area surrounding the batteries is an area of concern.

Batteries degrade over time meaning that they have a life cycle and after a certain period of time or a rough number of charges and discharges the batteries become unusable. The calendar or life cycle of a battery is the amount of time before the batteries nominal capacity falls below a specific threshold such as 80% whether being used or not<sup>11</sup>. Batteries can have shorter life cycles by drawing more current from the battery than it was designed for. Another reason is if a heavy load is suddenly placed upon the battery and the chemistry in the battery cannot keep up with the instantaneous current draw. Other reasons include storing batteries at excessively high or low temperatures, using a charger that was

designed for a different cell chemistry, overcharging or over-discharging or placing the battery under vibration.

The life span of a battery plays a large factor in the cost of a battery. If the acquisition cost is reasonably priced but the battery must be replaced often, then the overall cost of the battery dramatically increases. In other words, the cost of a battery cell is directly related to the life span. On top of continuous acquisition costs are the costs involved with disposal. Batteries must be disposed of appropriately where the heavy metals can be extracted and used for other applications<sup>13</sup>. The Mercury-Containing Rechargeable Battery Management Act of 1996 was passed by the Environmental Protection Agency in order to reduce hazardous materials from entering the environment and polluting the water systems. Later the Environmental Protection Agency set up the Universal Waste Regulations, cited under the Code of Federal Regulation (CFR) 40 part 23 that helps companies and corporations understand what needs to be recycled, where these items need to go and how they can get to appropriate recycling centers. Recycling centers like Battery Solutions, take various kinds of batteries, split them up, melt them down and collect the various metals used within them. From here the metals can be recycled depending upon the process to collect it. All of this costs money, however, meaning that the disposal costs must also be factored into the cost of the batteries.

#### **1.2.4 Electric Motors**

Another portion of the electrical system is the electric motor. Michael Faraday was the first person able to convert electrical or magnetic fields into mechanical power back in the early 1800's. His discovery led to many different forms of electric motors over the years. Tesla Motors, named after Nikola Tesla who patented the AC motor, make fully electric cars which use a 3-phase alternating current induction motor<sup>67</sup>. The Tesla motor weighs 115 pounds, requires 375 volts and up to 900 amperes in order to 288 HP which makes it one of the highest power to weight electric motors in production. The electric motor, according to Tesla Motors, is a far better option than an internal combustion engine because unlike an internal combustion engine there is only one moving part, the rotor. With only one piece moving, the complexity of the system decreases.

Electric motors offer several benefits including the ability to demand torque at any RPM within the motors operating range<sup>67</sup>. With the ability to demand torque at low RPM's, RPM's below 1000, gearing is no longer a necessity as it is with internal combustion engines. Less gearing means less weight.

One of the largest benefits to a fully electrical propulsion system, as opposed to an internal combustion engine, is the amount of energy converted to mechanical power. According to the US Department of Energy, electric motors tend to convert 75% of the energy in batteries to mechanics power to push the vehicle while internal combustion engines only convert around 20% of the energy stored in gasoline<sup>22</sup>. Both values include drive-train and gearing losses among others. The efficiency value for the internal combustion engine might be slightly inaccurate since the amount of energy stored in gasoline is determined by how much energy would be released if the gasoline were to undergo a chemical reaction. This energy density also does not take into account the oxygen and pressure that are required in order to ignite the fuel.

There are several motors that could prove to be applicable for use in electric aircraft. Single phase alternating current, Tesla’s 3-phase alternating current induction motor, brushless DC motors, and brushed DC motors would all prove as viable options for aviation purposes.

*Table 3: Comparison of Different Motors*<sup>8</sup>

Motor	Pros	Cons
AC Single-Phase	<ul style="list-style-type: none"> <li>• Good for small HP</li> <li>• AC power easier to change voltage with transformer than DC</li> </ul>	<ul style="list-style-type: none"> <li>• Current from batteries is DC, current would need to be converted to AC</li> <li>• Not generally available for high HP applications</li> </ul>
AC Multi-Phase	<ul style="list-style-type: none"> <li>• AC power easier to change voltage with transformer than DC</li> <li>• Can get higher HP motors than single phase</li> <li>• More control of power than single phase</li> </ul>	<ul style="list-style-type: none"> <li>• Current from batteries is DC, current would need to be converted to AC</li> <li>• Starting current can be high</li> <li>• Speed control is required</li> <li>• A multi-phase power supply is required</li> </ul>
DC Brushed	<ul style="list-style-type: none"> <li>• Current from batteries is DC, current does not need to be converted to AC</li> <li>• Cheaper and easier to make than brushless</li> <li>• Speed control is simple compared to DC Brushless</li> </ul>	<ul style="list-style-type: none"> <li>• Brushes can wear down and break</li> <li>• Brushes can arc and also create interference with electronic equipment</li> <li>• Can have high maintenance costs</li> <li>• DC power more difficult to change voltage than AC</li> </ul>
DC Brushless	<ul style="list-style-type: none"> <li>• Current from batteries is DC, current does not need to be converted to AC</li> <li>• No brushes</li> <li>• High efficiency</li> <li>• Low maintenance</li> </ul>	<ul style="list-style-type: none"> <li>• Costs more than brushed</li> <li>• Requires more complex speed control</li> <li>• DC power more difficult to change voltage than AC</li> </ul>

Table 3 describes two basic kinds of motors, Alternating Current (AC) and Direct Current (DC). Among these two motors are Single-Phase AC motors, which differ from Multi-phase AC motors by the different number of phases associated with the power supply<sup>32</sup>. AC Multi-Phase motors are known to have higher starting torques and have better control of the power than Single-Phase, however, the extra control requires more cost.

The DC motor has both brushed and brushless options. Brushed DC motors are simpler to build and do not require a complex control system, however, the brushes wear out over time and can arc<sup>32</sup>. Arcing can lead to an explosion if there are any flammable vapors around and can create interference with electronic components. Without brushes Brushless DC motors have a longer lifetime but they have a higher initial cost and require a most expensive and complex control system.

Of the four options both Multi-Phase AC and Brushless DC motors are currently the best options for the automotive industry and the aviation industry<sup>32</sup>. Batteries provide DC therefore in order to use an AC motor an inverter is required which decreases the efficiency of the overall system. This would suggest that Brushless DC motors might be the better option however the Brushless DC motors require high initial costs and complex control systems. If the transmission of power is examined, AC power is more efficient than DC. The voltage is easy to change with a transformer meaning that for the same power the current can be reduced with a higher voltage. Over distances lower current means less loss therefore high-voltage AC systems can be more efficient than low current-voltage DC systems. The answer to which motor best for the aviation industry concludes with either the Multi-Phase AC motor or the Brushless DC.

### **1.2.5 Electric Architectures**

There are several different fully electric airplane plan-forms that have been experimented with over the years. Hybrid solar power/batteries, fully electric and hybrid hydrogen fuel cell/battery are several of these different architectures. Each of these systems generates electricity and converts the electricity to mechanical power through an electric motor.

The hybrid solar power/battery option has been used on various high altitude airplanes including the Pathfinder, Helios, and Sunseeker projects<sup>42</sup>. The Pathfinder and Helios airplanes were able to extend their endurance and range by flying at high altitudes where the solar panels were more effective and the propeller experienced less drag. At this altitude the solar panels could recharge the batteries for night operations and if the battery endurance was not long enough to make it through the night, altitude was



available for the airplane to descend. Other airplanes like the Sunseeker have used similar technology and flown for 24 hours with a pilot on board.

Fully electric airplanes have demonstrated higher speeds but lack endurance as compared to an airplane with an internal combustion engine. As battery technology continues to evolve and energy density drops, the fully electric airplane's endurance continues to increase. The basic architecture is a pack of batteries, monitored and controlled connected to a DC motor or an inverter and then an AC motor.

The hybrid hydrogen fuel cell/battery plan-form was a test concept to prove the possibility of hydrogen fuel cells in airplanes. Airplanes are capable of flying with this type of plan-form, but the determination of whether these systems are appropriate for aviation usage has yet to be determined given the explosive nature of Hydrogen.

## 1.2.6 Hybrid Gas/Electric Architectures

### 1.2.6.1 Direct Drive (Parallel) Hybrid

There have been several hybrid airplanes over the previous few years however the Embry-Riddle Eco-Eagle was the first direct drive gas/electric hybrid system. In this setup the internal combustion engine was connected directly to the drive shaft and the electric motor was offset from the drive shaft with a clutch and pulley system.

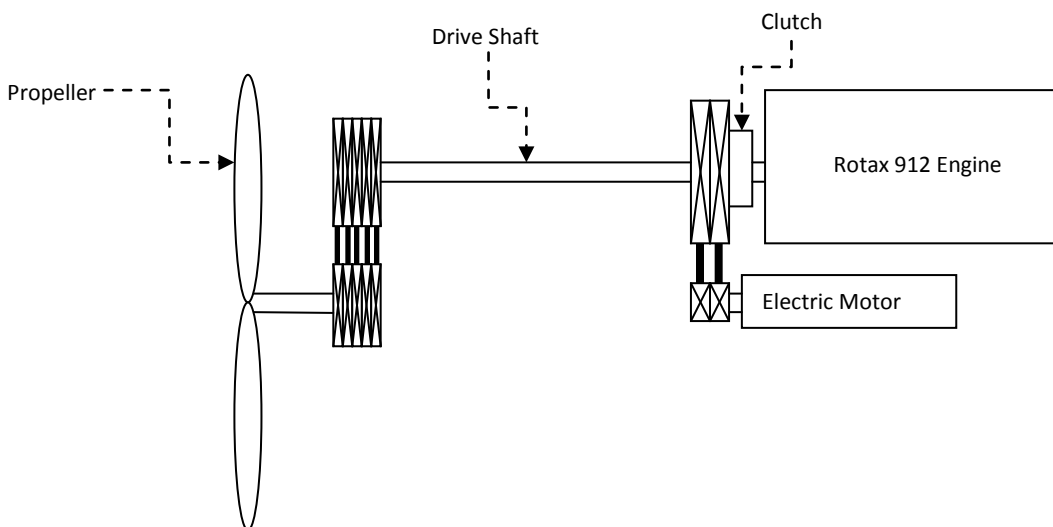

Figure 5: Eco-Eagle Propulsion System

Figure 5 depicts the Eco-Eagle propulsion system with the gas engine and electric motor on the far right connected via an over-running clutch with pulleys encasing the clutch. These pulleys were designed, tested, made and installed by Embry-Riddle in order to interface with a Formsprag FSO 300 over-running clutch. While the gas engine runs and drives the propeller, the electric motor spins freely creating very little resistance and loading of the system; then when the electric motor drives the propeller, the clutch engages and the gas engine does not turn. If anything were to ever happen to the electric motor the gas engine was in line with the drive shaft and could be engaged to drive the propeller.

There are several benefits to a system similar to the Eco-Eagle hybrid propulsion setup. In this system the gas engine was the primary propulsive force and the source of power that was most tested. If something happened to the battery system or the electric motor the gas engine could easily be restarted in flight assuming the batteries that failed are not needed to start the engine. With new electric motors and battery systems this hybrid setup would allow for a test bed flight environment for such systems.

Another benefit of this system allows the pilot to fly greater distances without the necessity of recharging for several hours between legs of a long duration flights. The battery system would act as an endurance boost but would not be required for use in every single flight. While it would be beneficial to the airplanes fuel consumption to stop and recharge and use the battery system as much as possible, long duration flights with multiple stops would not require it. Distances between stops would be shorter with no battery power, however, unlike a fully electric airplane with the recharging capabilities today and the recharge locations available to pilots, it might not be practical.

#### ***1.2.6.2 Serial Hybrid***

Along with the parallel hybrid gas-electric airplane is the serial hybrid version. The first was built by Diamond, Siemens and EADS which used a HK36 Dimona motor glider by Diamond and installed a 94 HP electric motor that was powered by either batteries or a Wankel engine from Austro Engine<sup>74</sup>. This setup alleviated the complexity of the propulsion system however it did not provide the benefits of the last system. The Wankel engine did provide a better power to weight ratio than a traditional reciprocating engine and might be slightly more efficient but there was still a loss through the electric motor. In the case of the Eco-Eagle, ignoring the losses in the pulleys, the gas engine directly drives the propeller, but with the Siemen's Dimona airplane, there is another loss in line to the propeller. The electric motor was running at around 90% efficient but that meant that 10% of the energy sent from the Wankel engine on

top of an efficiency loss from the power junction was lost on its way to the propeller. The Eco-Eagle had no loss between the internal combustion engine and the propeller.

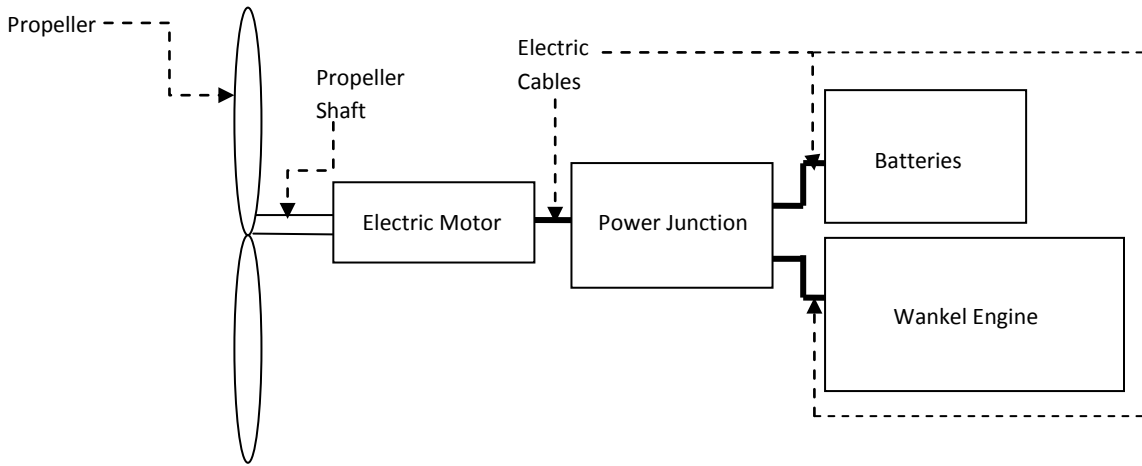

Figure 6: Siemens, AEDS, and Diamonds Series Gas/Electric Hybrid Propulsion System<sup>74</sup>

### 1.2.7 Green Flight Challenge

The Green Flight Challenge was a competition sponsored by NASA and hosted by the CAFE Foundation for the purpose of stimulating efficient airplane design. The competition set three basic rules and offered up a \$1.5 million prize for the team that could meet the requirements and perform the best. The basic rules were that the airplane had to travel over a 200 mile course while averaging at least 100 mph and achieving at least 200 passenger-mpg. In order to measure the miles per hour the 200 mile course had to be completed in under two hours and starts from brake release on the runway. Measuring miles passenger miles per gallon was based upon unleaded 87 octane gasoline. In order to make a conversion to energy the Environmental Protection Agency established a value of 33.7 kWh was stored in a gallon of gasoline by burning one gallon and determining the amount of energy released<sup>58</sup>. Burning a gallon of 87 octane gasoline releases 115,000 BTU and in order to create the same amount of heat 33.7 kWh is required, therefore there are 33.7 kWh in one gallon of gasoline. For the competition, the amount of energy was measured between the batteries and the motor for each flight of the electric airplanes and converted to mpg, once this was done the number of passengers, or pilots, was multiplied to the mpg in order to get passenger-mpg.

The competition was held in California and consisted of two separate flights where all three requirements had to be made during both flights. After landing the second flight, a 30 minute reserve was required and measured from each of the planes that met the requirements for the first flight.

Of the twelve teams that originally registered for the competition and were accepted, only four finally made it out to California for the competition; the Eco-Eagle by Embry-Riddle, the PhoEnix, the G4 by Pipistrel, the EGenius. The Eco-Eagle was a hybrid airplane, Phoenix was a fully gas powered airplane, and Pipistrel plane and the EGenius were the only two fully electric airplanes. Of the four planes only two were able to meet the requirements set forth by the competition; Pipistrel and EGenius which demonstrated that if the goal was efficient flight, electricity looked extremely promising.

Deconstructing the data from the competition could help to describe what the current level of electric and airplane technology is required in order to make electric airplanes viable alternatives. Is the fully electric airplane the immediate future or are we still a little ways away? Can we put these extremely efficient and well designed battery systems into any airplane and expect similar results? Of course not, but why? This competition demonstrated that electric battery systems and motors could lead to high speeds and little energy, however, aerodynamics is once again a key factor in ensuring success of these current systems.

Hybrid airplanes, like hybrid cars, could be an interim step to fully electric airplanes. While hybrid airplanes are far more complex than just the gas system or just the electric, they offer a backup system for the electrical system and if done in a similar fashion to the Eco-Eagle, can offer a test bed for various battery systems without risk of the batteries not working. In the case of the Eco-Eagle the drive shaft was connected to the gas engine with a clutch and pulley system off-set to the electric motor. If the electric motor or the batteries ever refused to work the gas engine could always start back up again and resume powered flight.

There are many new design criteria that need to be considered when designing or modifying an airplane for electric powered flight. Thanks to the NASA Green Flight Challenge, while not a large abundance of data, data does now exist that can shape and provide steps and ideas in order to design newer and better electric airplanes.

### 1.2.7.1 Eco-Eagle

The only hybrid airplane to show up for the competition was disqualified for not having a Ballistic Recovery System as defined by the rules and for not flying two passengers in their two passenger airplane. While the team was disqualified from the monetary prize the team was allowed to compete against the other teams. The Eco-Eagle, Embry-Riddle's team chose a Stemme S10 motor-glider and made modifications to the airframe by adding a parallel hybrid gas/electric system.

Table 4: Eco-Eagle Airplane Technical Data<sup>60</sup>

Parameter	Eco-Eagle
Wing Span	75 ft
Empty Weight	1970 lb
Competition Weight	2370 lb
Maximum HP	100 HP
Stall Speed	52 mph
Passengers	2

Table 4 shows the technical data of the Eco-Eagle that was ascertained from both the Green Flight Challenge competition data<sup>60</sup>. This data can be used later on to determine various elements of the hybrid style airplane platform.

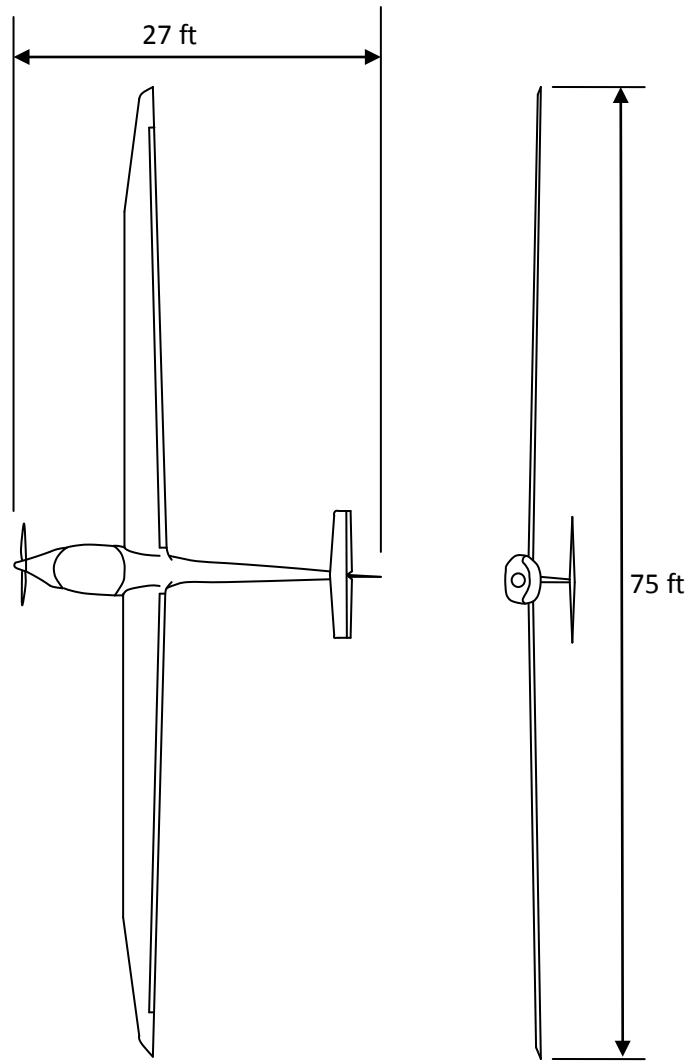

*Figure 7: 3-View Drawing of the Eco-Eagle<sup>64</sup>*

Figure 7 shows the 3-view drawing of the 2 passenger motor-glider. The airframe greatly resemble the unmodified Stemme S10 except for the nose and propeller. Originally the propeller could be retracted into the nose cone, however the new configuration keeps the propeller out in the airflow at all times.

### 1.2.7.2 Phoenix

The only competitor in the Green Flight Challenge not to use any form of electric propulsion was the Phoenix team. This team used a Czech standard production motor-glider from the PhoEnix Company. The propeller was mounted upon the nose of the airplane and was driven by a Rotax 912 gas engine.

Table 5: Phoenix Airplane Technical Data<sup>60</sup>

Parameter	Phoenix
Wing Span	49 ft
Empty Weight	727 lb
Competition Weight	1320 lb
Maximum HP	100 HP
Stall Speed	49 mph
Passengers	2

Table 5 shows the technical data of the Eco-Eagle that was ascertained from both the Green Flight Challenge competition data<sup>60</sup>. This data can be used later on to determine various elements of a very efficient gas power style airplane plan-form.

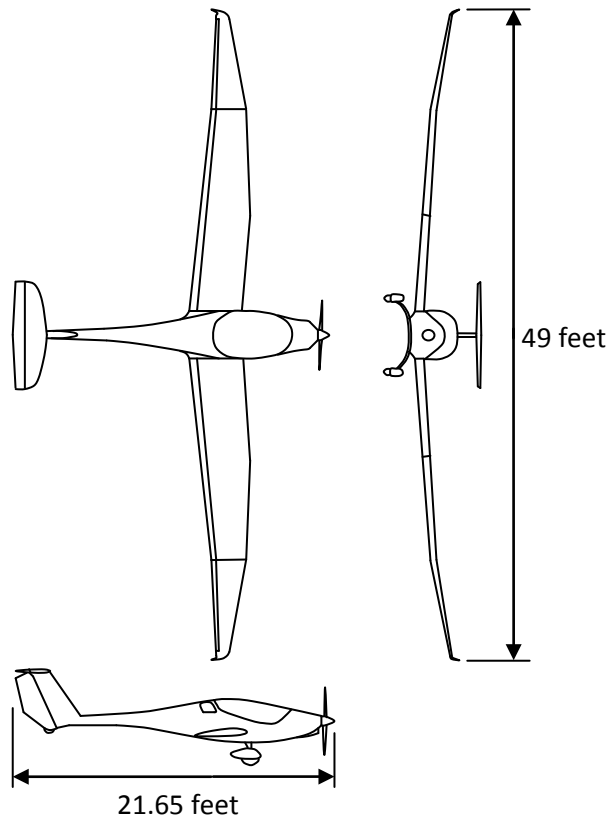

Figure 8: 3-View Drawing of the Phoenix Airplane<sup>55</sup>

Figure 8 shows the 3-view drawing of the Phoenix airplane. The propeller on this airplane had the capability of fully feathering the propeller for gliding profiles.

### 1.2.7.3 Pipistrel

Pipistrel was a motor-glider and airplane manufacturer out of Slovenia. In order to make their new G4 airplane for the competition, the company took two of their Taurus airplane fuselages and connected them via a large wing body with a nacelle for the electric motor and propeller. Figure 1 shows the scaled 3-view drawing of the Pipistrel G4 airplane and some overall dimensions.

*Table 6: Competition Team Data as published by CAFE<sup>60</sup>*

<b>Parameter</b>	<b>Pipistrel</b>
Wing Span	69 ft 2 in
Empty Weight	2490.8 lb
Competition Weight	3294.1 lb
Maximum HP	194 HP
Stall Speed	52 mph
GFC Speed ( $V_{ave}$ )	113.7 mph
PMPG	403.5
GFC Noise	71.1 dBA
Passengers	4

Table 6 shows the technical data of the Pipistrel that was ascertained from both the Green Flight Challenge competition data (Green Flight Challenge Results). This data can be used later on to determine various elements of the electric power airplane plan-form.



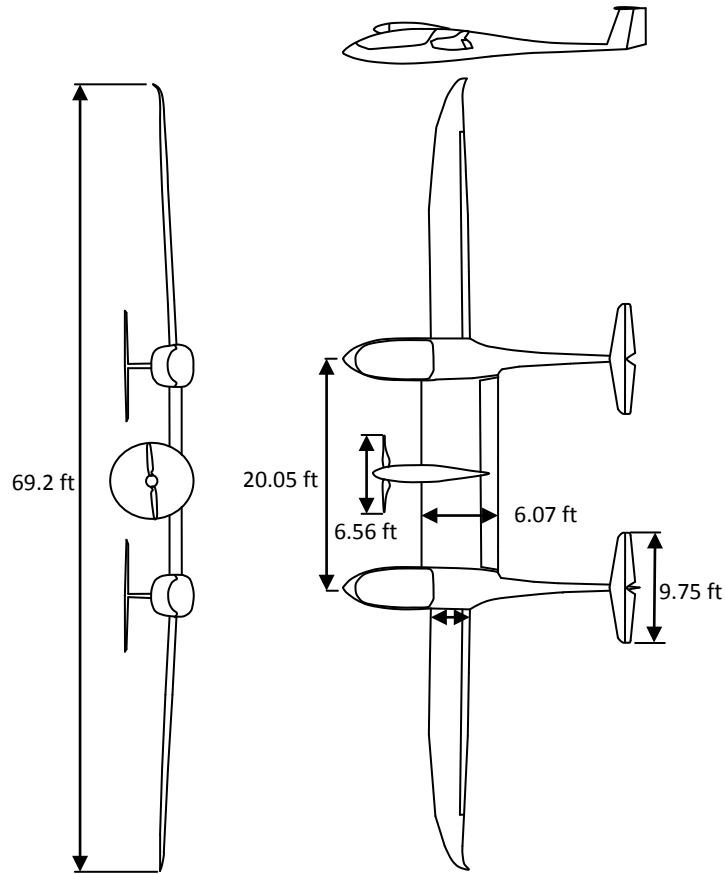

*Figure 9: Pipistrel G4 3-View Drawing*

Figure 9 shows the 3-view drawing of the Pipistrel G4 airplane. Here the twin fuselages of Pipistrel G2 motor-glider are clearly visible along with the center nacelle with the propeller and engine mount.

#### **1.2.7.4 EGenius**

The EGenius team out of Germany took a fuselage that had been specifically made for a hydrogen powered airplane and filled it with batteries instead of fuel cells. The fuselage was specifically made for reduced drag and high efficiency with the propeller on the tail and high aspect ratio wings. Figure 2 shows a 2-view drawing of the EGenius airplane with rough overall dimensions. The EGenius was first flown on May 25<sup>th</sup>, 2011<sup>54</sup>.

Table 7: Competition Team Data as Published by CAFE<sup>60</sup>

Parameter	E-Genius
Wing Span	55 ft 5 in
Empty Weight	1670.2 lb
Competition Weight	2070.2 lb
Maximum HP	80.4 HP
Stall Speed	52 mph
GFC Speed ( $V_{ave}$ )	107.4 mph
PMPG	375.8
GFC Noise	59.5 dBA
Passengers	2

Table 7 shows the technical data of the EGenius that was ascertained from both the Green Flight Challenge competition data (Green Flight Challenge Results). This data can be used later on to determine various elements of an electric power airplane different than the Pipistrel plan-form.

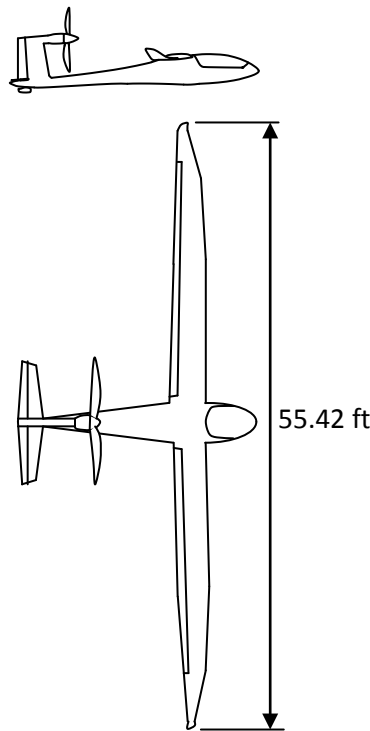

Figure 10: EGenius 2-View Drawing

Figure 10 shows the 3-view drawing of the airplane. The wings used for this airplane were the same as those used for the for Pipistrel airplane.

## Chapter 2: Theory

### 2.1 Derivation of Classical Range and Endurance Equations for Electric Propulsion

#### 2.1.1 Electric Airplane Flight Profile Eqn. Derivation: Range

The flight profile of the electric airplane may not be the same as that for an internal combustion engine airplane. The first step in order to determine an appropriate flight profile would be to examine range (R) and endurance (T) and their relation to electric airplanes<sup>7</sup>.

$$R = -\frac{\eta_p \left(\frac{L}{D}\right)}{SFC_T} \int_{W_1}^{W_2} \frac{dW}{W} \quad \text{Eqn. 1 (3.59)}$$

Eqn. 1 describes the best range for a propeller driven airplane.  $SFC_T$  is defined as the ratio of the fuel mass flow to the engine thrust which is a method for determining how efficient the engine is in providing thrust from a certain mass flow. This value is affected by altitude and will decrease as altitude increases due to the reduction in air density.

There are three or four items in Eqn. 1 that can affect the range;  $SFC_T$ , velocity (V), drag (D), and weight (W). Of these four,  $SFC_T$  is based upon the engine performance and altitude and unless the engine is changed only altitude can play a factor. Drag is a function of velocity and will be the lowest value, which for Eqn. 1 would make the longest range, at the velocity where the best L/D is obtained. The final item, weight, is dependent upon the fuel burn and the amount of fuel stored and compares the original weight of the airplane with full fuel to the final weight of the airplane with no fuel. The weight difference can only be changed if the amount of fuel carried is increased or decreased, or the engine is changed.

Eqn. 1 can be used for propeller driven airplanes with internal combustion engines, however, it cannot be used for electric airplanes. The weight of an electric airplane does not change during the flight profile. If the weight does not change that Eqn. 1 says that there was no thrust produced because this Eqn. is based on the assumption that the weight of the fuel decreasing with time is directly proportional to the power<sup>7</sup>. If there is no fuel burn, there is no thrust and there is no range.

A new range equation must be derived for electric airplanes. Returning to the original definition of range as the distance an airplane can travel on a certain fuel payload now becomes the distance given a capacity electrical energy stored on board the airplane.

$$R_e = VT \quad \text{Eqn. 2}$$

Eqn. 2 represents the most basic definition of range, however, the total time and the velocity are unknown. Since electric airplanes store a specific amount of energy and that energy is based on both power and time, the following can be said.

$$T = \frac{E_T}{P} \quad \text{Eqn. 3}$$

$E_T$  is the total energy stored on board the electric airplane, and  $P$  is the power available and  $V$  is the velocity.

$$P = DV \quad \text{Eqn. 4}$$

Eqn. 4 is the basic definition of Power which is defined by the drag ( $D$ ) of the vehicle and the velocity ( $V$ ). As mentioned above, drag is a function of velocity and can change, just as power can, with different airspeeds.

$$D = \frac{1}{2}\rho V^2 S C_D \quad \text{Eqn. 5}$$

Now, the relationship that drag has with velocity is apparent. In Eqn. 5),  $\rho$  is the density of air,  $S$  is the plan-form area of the wing, and  $C_D$  is the coefficient of drag.  $C_D$  is dependent upon velocity and can be defined as<sup>7</sup>:

$$C_D = C_{D_o} + \frac{1}{\pi A e} C_L^2 \quad \text{Eqn. 6}$$

In Eqn. 6,  $C_{D_o}$  is the minimum drag coefficient,  $A$  is the aspect ratio of the wing and  $e$  is Oswald's efficiency which takes into account the shape of the wing, geometric twist and several other factors<sup>7</sup>.

Eqn. 6 has one more variable which relies on airspeed which is  $C_L$ , the coefficient of lift.

$$C_L = \frac{L}{\frac{1}{2}\rho V^2 S} \quad \text{Eqn. 7}$$

Eqn. 7 defines the coefficient of lift. In cruising level flight, which is the assumption for the derivation of range, the lift ( $L$ ) can be equated to the weight of the airplane. The range of the electric airplane can now be solved for by inserting Eqn. 3, 4, 5, 6, and 7 back into Eqn. 2.

$$R_e = \frac{E_T}{\frac{1}{2}\rho V^2 S (C_{D_o} + \frac{1}{\pi A e} (\frac{W}{\frac{1}{2}\rho V^2 S})^2)} \quad \text{Eqn. 8}$$

Eqn. 8 is the new range equation for electric airplanes. This equation takes into account the energy stored onboard the airplane and the aerodynamic properties of the airplane.

In the range equation for propeller driven internal combustion airplanes, Eqn. 1, has two main variables that drive the equation, assuming the airplane itself is not changed, the altitude and velocity.  $A$

different altitude means a different  $SFC_T$  and a different velocity, besides changing in the equation, also changes the drag.

For internal combustion engine airplanes, the best altitude occurs at sea level where the air density is the highest. Electric airplanes, however, do not pressurize a fuel with oxygen and ignite it, therefore the best altitude may not be at sea level.

Eqn. 8, which describes the range for an electric airplane, has one variable that is dependent upon altitude, which is  $\rho$ . This variable has two basic equations that model it according to what altitude range is being examined. For operations below 36,000 feet Eqn. 9 is used.

$$\rho_1 = \rho_o(1 - 6.88 \times 10^{-6} h)^{4.256} \quad \text{Eqn. 9}$$

For operations at and above 36,000 feet, Eqn. 10 is used.

$$\rho_2 = 0.297 \rho_o e^{(-4.87 \times 10^{-5} (h - 36000))} \quad \text{Eqn. 10}$$

First the best airspeed for the best range will be determined. This assumes that the altitude is constant which means that the density is constant. Eqn. 11 and 12 are for simplification and plugged back into Eqn. 8.

$$Q(v) = \frac{1}{\frac{1}{2} \rho v^2 S} \quad \text{Eqn. 11}$$

$$K = \frac{W^2}{\pi A e} \quad \text{Eqn. 12}$$

Eqn. 13 is the Range equation derived in Eqn. 8 but with substitutions Q and K.

$$R_e = \frac{E_T Q}{C_{D_o} + K Q^2} \quad \text{Eqn. 13}$$

In order solve for the optimum velocity that will obtain the best range, Eqn. 14 must be used. This takes the derivative of Eqn. 11 with respect to velocity and Eqn. 13 with respect to Q.

$$\frac{dR_e}{dv} = \frac{dQ}{dv} \frac{dR}{dQ} \quad \text{Eqn. 14}$$

Taking the derivative of Eqn. 11 with respect to velocity, yields Eqn. 15.

$$\frac{dQ}{dv} = \frac{-4}{\rho v^3 S} \quad \text{Eqn. 15}$$

The next step involves taking the derivative of Eqn. 13 with respect to Q; this is seen in Eqn. 16.

$$\frac{dR_e}{dQ} = E_T((C_{D_o} + KQ^2)^{-1} - Q(C_{D_o} + KQ^2)^{-2}(2KQ)) \quad \text{Eqn. 16}$$

$$\frac{dR_e}{dQ} = E_T(1 - (C_{D_o} + KQ^2)^{-1}(2KQ^2)) \quad \text{Eqn. 17}$$

Eqn. 17 is a simplified version of Eqn. 16. Now that both desired derivatives have been found in order to satisfy Eqn. 14,  $\frac{dR}{dv}$  can be solved for and since the maximum velocity is desired, or a local maximum, Eqn. 14 is set to zero. In order for Eqn. 18 to be true either Eqn. 15 or Eqn. 17 must be equal to zero.

$$\frac{dR_e}{dv} = \frac{dQ}{dv} \frac{dR_e}{dQ} = 0 \quad \text{Eqn. 18}$$

The only way for Eqn. 15 to be zero is if v goes to infinity, therefore we can disregard this equation since physically this makes no sense for an airplane to have an infinite airspeed, thus Eqn. 17 is set equal to zero.

$$1 = (C_{D_o} + KQ^2)^{-1}(2KQ^2) \quad \text{Eqn. 19}$$

Eqn. 19 is step after Eqn. 17 was set equal to zero. The total energy ( $E_T$ ) disappears from the equation since this value cannot be equal to zero. If  $E_T$  did equal zero than the airplane would have no stored energy and no means to produce power, disregarding atmospheric conditions.

$$Q = \sqrt{\frac{C_{D_o}}{K}} \quad \text{Eqn. 20}$$

Eqn. 20 is further simplified from Eqn. 19. The definition of Q above in Eqn. 11 can now be easily plugged into Eqn. 20 in order to solve for v.

$$\frac{2}{\rho v^2 S} = \sqrt{\frac{C_{D_o}}{W^2} \pi A e} \quad \text{Eqn. 21}$$

Now, through algebra, Eqn. 21 can be solved for v. Eqn. 22 is the optimum airspeed for the best range of a fully electric airplane.

$$v = \sqrt{\frac{2}{\rho S \sqrt{\frac{C_D}{W^2} \pi A e}}} \quad \text{Eqn. 22}$$

Now searching for the optimum altitude in order to achieve the best range, Eqn. 8 is used and several simplifications are followed. The altitude is in terms of density therefore, Eqn. 9 will first be examined which defines density with respect to altitude below 36,000 feet.

$$\rho_1 = \rho_o(1 - 6.88x10^{-6}h)^{4.256} \quad \text{Eqn. 9}$$

In order to simplify the following calculations, Q and K are defined in Eqn. 11 and 12.

$$Q(h) = \frac{1}{\frac{1}{2}\rho_1 v^2 S} \quad \text{Eqn. 23}$$

$$K = \frac{W^2}{\pi A e} \quad \text{Eqn. 12}$$

Plugging Eqn. 11 and Eqn. 12 into Eqn. 8 yields Eqn. 13.

$$R_e = \frac{E_T Q}{C_{D_o} + KQ^2} \quad \text{Eqn. 13}$$

This time the derivative will be taken of Eqn. 13 but with respect to the altitude (h).

$$\frac{dR_e}{dh} = \frac{dQ}{dh} \frac{dR}{dQ} \quad \text{Eqn. 24}$$

Eqn. 24 is the method by which the derivative will be taken of the Range (R) stated in Eqn. 13 with respect to altitude (h). The first step involves taking the derivative of Q, Eqn. 11 with respect to altitude.

$$\frac{dQ}{dh} = \frac{-2.93x10^{-5}(1-6.88x10^{-6}h)}{\frac{1}{2}\rho_o v^2 S} \quad \text{Eqn. 25}$$

Eqn. 24 is the derivative of Q with respect to h with the density equation, Eqn. 9 plugged into Eqn. 11.

The next step is to take the derivative of R represented in Eqn. 13 with respect to Q.

$$\frac{dR_e}{dQ} = E_T((C_{D_o} + KQ^2)^{-1} - Q(C_{D_o} + KQ^2)^{-2}(2KQ)) \quad \text{Eqn. 26}$$

$$\frac{dR_e}{dQ} = E_T(1 - (C_{D_o} + KQ^2)^{-1}(2KQ^2)) \quad \text{Eqn. 27}$$

Eqn. 26 is the derivative of R with respect to Q. Eqn. 27 is a simplification of Eqn. 26. Both Eqn. 26 and Eqn. 27 are identical to Eqn. 16 and 17 in the previous derivation.

$$\frac{dR_e}{dh} = \frac{dQ}{dh} \frac{dR_e}{dQ} = 0 \quad \text{Eqn. 28}$$

In order to solve for the optimum altitude Eqn. 24 is set equal to zero in Eqn. 28. The only way that Eqn. 28 can be true is if either or both  $\frac{dQ}{dh}$  and  $\frac{dR_e}{dQ}$  are zero. In this case, the only way for Eqn. 25 to be zero would mean that the altitude was infinite. Therefore, Eqn. 27 is set equal to zero and the altitude is solved for.

$$1 = (C_{D_o} + KQ^2)^{-1}(2KQ^2) \quad \text{Eqn. 29}$$

$$Q = \sqrt{\frac{C_{D_o}}{K}} \quad \text{Eqn. 30}$$

Eqn. 29 and 30 are steps after Eqn. 26 was set equal to zero. Both Eqn. 29 and 30 are identical to Eqn. 19 and 20.

$$\frac{1}{\rho_o(1-6.88x10^{-6}h)^{4.256}V^2S} = \sqrt{\frac{C_{D_o}}{K}} \quad \text{Eqn. 31}$$

Plugging Eqn. 11 into Eqn. 30 yields Eqn. 31. From Eqn. 31 the altitude can be solved for.

$$(1 - 6.88x10^{-6}h)^{4.256} = \frac{1}{\frac{1}{2}\rho_oV^2S\sqrt{\frac{C_{D_o}}{K}}} \quad \text{Eqn. 32}$$

$$h = \frac{1 - 4.256 \sqrt{\frac{1}{\frac{1}{2}\rho_oV^2S\sqrt{\frac{C_{D_o}}{K}}}}}{6.88x10^{-6}} \quad \text{Eqn. 33}$$

Eqn. 32 was a step toward finding the altitude in Eqn. 33. Now the altitude can be found for fully electric airplanes.

The last derivation involving the range equation derived in Eqn. 8 will be to examine altitude above 36,000 feet; for this Eqn. 8 and Eqn. 10 will be needed.

$$\rho_2 = .297\rho_o e^{-4.87x10^{-5}(h-36000)} \quad \text{Eqn. 10}$$

In order to make the following equations easier, several substitutions were made in the form of Eqn. 34 and Eqn. 12.



$$Q_2(v) = \frac{1}{\frac{1}{2}\rho_2 v^2 S} \quad \text{Eqn. 34}$$

$$K = \frac{W^2}{\pi A e} \quad \text{Eqn. 12}$$

Now, the range Eqn. 8 becomes Eqn. 35.

$$R_e = \frac{E_T Q_2}{C_{D_o} + K Q_2^2} \quad \text{Eqn. 35}$$

Eqn. 36 will solve for the optimum altitude above 36,000 feet for the best range. Eqn. 36 requires that the derivative of  $Q_2$  be taken with respect to altitude and that Eqn. 35 be differentiated with respect to  $Q_2$ .

$$\frac{dR_e}{dh} = \frac{dQ_2}{dh} \frac{dR_e}{dQ_2} \quad \text{Eqn. 36}$$

First, Eqn. 34 is differentiated with respect to altitude which requires that Eqn. 10 be plugged into Eqn. 34. Eqn. 37 is the derivative of  $Q_2$  with respect to  $h$ .

$$\frac{dQ_2}{dh} = \frac{3.27 \times 10^{-4} e^{-4.87 \times 10^{-5}(h-36000)}}{\rho_0 v^2 S} \quad \text{Eqn. 37}$$

The next step would be to take the derivative of Eqn. 35 with respect to  $Q_2$ ; Eqn. 38 is this derivative and Eqn. 39 is a simplified version of Eqn. 38.

$$\frac{dR_e}{dQ_2} = E_T ((C_{D_o} + K Q_2^2)^{-1} - Q_2 (C_{D_o} + K Q_2^2)^{-2} (2K Q_2)) \quad \text{Eqn. 38}$$

$$\frac{dR_e}{dQ_2} = E_T (1 - (C_{D_o} + K Q_2^2)^{-1} (2K Q_2^2)) \quad \text{Eqn. 39}$$

In order to obtain the optimum velocity Eqn. 36 is set equal to zero. For this to be true, either or both Eqn. 37 and Eqn. 39 must equal zero.

$$\frac{dR_e}{dv} = \frac{dQ_2}{dv} \frac{dR_e}{dQ_2} = 0 \quad \text{Eqn. 40}$$

If Eqn. 37 is set equal to zero, the only way for this to happen is if Eqn. 41 is true.

$$e^{-4.87 \times 10^{-5}(h-36000)} = 0 \quad \text{Eqn. 41}$$

Eqn. 41 can only be true if h goes to infinity.

$$1 = (C_{D_o} + KQ_2^2)^{-1}(2KQ_2^2) \quad \text{Eqn. 42}$$

$$Q_2 = \sqrt{\frac{C_{D_o}}{K}} \quad \text{Eqn. 43}$$

Eqn. 42 is a simplified version after Eqn. 39 was set equal to zero. Using Eqn. 43, the optimum altitude can now be solved for by plugging in Eqn. 34.

$$\frac{1}{.297\rho_0 e^{-4.87 \times 10^{-5}(h-36000)} \frac{1}{2} V^2 S} = \sqrt{\frac{C_{D_o}}{K}} \quad \text{Eqn. 44}$$

$$-4.87 \times 10^{-5}(h - 36000) = \ln\left(\frac{1}{1.68\rho_0 V^2 S \sqrt{\frac{C_{D_o}}{K}}}\right) \quad \text{Eqn. 45}$$

Eqn. 44 and 45 are steps toward figuring out the optimum altitude. By plugging in Eqn. 34, simplifying and taking the natural log of both sides of the equation, Eqn. 46 could be found.

$$h = \frac{\ln\left(\frac{1}{1.68\rho_0 V^2 S \sqrt{\frac{C_{D_o}}{K}}}\right) - 1.75}{-4.87 \times 10^{-5}} \quad \text{Eqn. 46}$$

Eqn. 46 is the optimum altitude for the best range at an altitude above 36,000 feet.

### 2.1.2 Electric Airplane Flight Profile Eqn. Derivation: Endurance

The endurance of an airplane is defined as the amount of time an airplane can fly with a specific amount of fuel. In order to maximize the endurance, the least amount of power must be used.

$$T = \frac{\eta_p E_{MP}}{SFC_P V_{MP}} \ln\left(\frac{W_1}{W_2}\right) \quad \text{Eqn. 47}$$

Eqn. 28 defines the maximum endurance for an internal combustion engine airplane. This equation relies on aerodynamic properties such as the efficiency of the propeller ( $\eta_p$ ), the L/D for minimum power ( $E_{MP}$ ), and also relies on the ratio between the engine fuel mass flow to the power of the engine ( $SFC_P$ ), the airspeed for minimum power ( $V_{MP}$ ),  $W_1$  is the weight of the airplane before takeoff and  $W_2$  is the weight of the airplane after landing (fuel burn ratio).

For electric airplanes the amount of fuel burned is zero, therefore  $\zeta$  is zero and the natural log of 1 is zero. If there is no change in fuel weight than the airplane is said to have no endurance as per Eqn. 28. A new equation must then be derived for electric airplanes.

$$T = \frac{E_T}{\frac{dE}{dt}} \quad \text{Eqn. 48}$$

Eqn. 29 is the basic definition of endurance which relates the total energy stored on board the airplane ( $E_T$ ) to the rate of change of energy with time ( $\frac{dE}{dt}$ ). The slower the energy is consumed, the longer the airplane will be able to fly and the larger the endurance will be.

The rate of change of energy with time, or the discharge, is dependent upon the aerodynamics of the airplane. In order to compare ( $\frac{dE}{dt}$ ) to aerodynamic values reference must be made back to Eqn. 3), 4), 5), 6), and 7).

$$T = \frac{E_T}{P} \quad \text{Eqn. 3}$$

$$P = DV \quad \text{Eqn. 4}$$

$$D = \frac{1}{2}\rho V^2 S C_D \quad \text{Eqn. 5}$$

$$C_D = C_{D_o} + \frac{1}{\pi A e} C_L^2 \quad \text{Eqn. 6}$$

$$C_L = \frac{L}{\frac{1}{2}\rho v^2 S} \quad \text{Eqn. 7}$$

Using these five equations an equation can be determined for the endurance of an electric airplane.

$$T = \frac{E_T}{\frac{1}{2}\rho V^3 S (C_{D_o} + \frac{1}{\pi A e} (\frac{W}{\frac{1}{2}\rho V^2 S})^2)} \quad \text{Eqn. 49}$$

Eqn. 30 this equation now defines the endurance for an electric airplane. This equation relates the total energy of the airplane to aerodynamic properties and can only be changed based upon the altitude and the velocity. These two variables are the only ones that can be changed in a flight. The other values are all airplane specific and can only be changed if the airplane is changed.

First the optimum velocity for the best endurance was calculated. Similarly as during the range calculations, several parameters were defined in order to make the following calculations easier.

$$\beta(v) = \frac{1}{v} \quad \text{Eqn. 50}$$

$$K = \frac{W^2}{\pi A e} \quad \text{Eqn. 51}$$

$$M = \frac{1}{\frac{1}{2}\rho S} \quad \text{Eqn. 52}$$

Eqn. 50, 51, and 52 can all be plugged into Eqn. 49. Eqn. 53 is the product of this substitution.

$$T = \frac{E_T \beta^3 M}{C_{D_o} + \beta^4 M^2 K} \quad \text{Eqn. 53}$$

In order to solve for the optimum velocity for the best endurance, the derivative of Eqn. 53 must be taken with regards to  $v$ . In order to make this an easier problem to solve, Eqn. 54 breaks up the derivative.

$$\frac{dT}{dv} = \frac{dT}{d\beta} \frac{d\beta}{dv} \quad \text{Eqn. 54}$$

The first derivative was taken of Eqn. 50 with respect to velocity. Eqn. 55 is the solution to that derivation.

$$\frac{d\beta}{dv} = \frac{-2}{v^2} \quad \text{Eqn. 55}$$

Next, the derivative was taken of Eqn. 53 with respect to  $\beta$ ; Eqn. 56 is this differentiation.

$$\frac{dT}{d\beta} = E_T M (3\beta^2 (C_{D_o} + \beta^4 M^2 K)^{-1} - \beta^3 (C_{D_o} + \beta^4 M^2 K)^{-2} (4\beta^3 M^2 K)) \quad \text{Eqn. 56}$$

$$\frac{dT}{dv} = \frac{dT}{d\beta} \frac{d\beta}{dv} = 0 \quad \text{Eqn. 57}$$

In order to find the maximum or optimum airspeed, Eqn. 54 must be set equal to zero. For this to be true, either or both Eqn. 55 or Eqn. 56 must equal zero. Since the only way for Eqn. 55 to equal zero is if  $v$  goes to infinity, Eqn. 56 must equal zero. An infant value of velocity is not practical for these purposes.

$$0 = E_T M \left( 3\beta^2 - \frac{\beta^6 M^2 K^4}{C_{D_o} + \beta^4 M^2 K} \right) \quad \text{Eqn. 58}$$

$$\frac{4}{3}\beta^6 M^2 K - \beta^4 M^2 K - C_{D_o} = 0 \quad \text{Eqn. 59}$$

Eqn. 58 and Eqn. 59 are the results of setting Eqn. 56 equal to zero. From here further simplification is made by saying that  $x = \beta^2$ .

$$v^4 = \frac{1}{\frac{3C_{D_0}}{M^2 K}} \quad \text{Eqn. 60}$$

Now, the optimum altitude must be determined in order to find the best endurance for below 36,000 feet.

$$T = \frac{E_T}{\frac{1}{2}\rho v^3 S (C_{D_0} + \frac{1}{\pi A e} (\frac{W}{\frac{1}{2}\rho v^2 S})^2)} \quad \text{Eqn. 49}$$

Eqn. 49 is used and simplified by making substitutions

$$\beta = \frac{1}{v} \quad \text{Eqn. 61}$$

$$K = \frac{W^2}{\pi A e} \quad \text{Eqn. 62}$$

$$M_1(h) = \frac{1}{\frac{1}{2}\rho_1 S} \quad \text{Eqn. 63}$$

Eqn. 61, 62, and 63 were substituted into Eqn. 49 in order to make the following calculations simpler.

$$\rho_1 = \rho_0 (1 - 6.88 \times 10^{-6} h)^{4.256} \quad \text{Eqn. 9}$$

Eqn. 9 will be plugged into Eqn. 63 to account for changes in density as the altitude changes from sea level to 36,000 feet. Eqn. 64 is the outcome.

$$T = \frac{E_T \beta^3 M_1}{C_{D_0} + \beta^4 M_1^2 K} \quad \text{Eqn. 64}$$

In order to solve for the optimum altitude that will produce the best endurance, the derivative of Eqn. 49 must be taken with respect to  $M_1$  and the derivative of  $M_1$  must be taken with respect to  $h$ .

$$\frac{dT}{dh} = \frac{dT}{dM_1} \frac{dM_1}{dh} \quad \text{Eqn. 65}$$

Eqn. 66 is the derivative of Eqn. 63 with respect to  $h$ .

$$\frac{dM_1}{dh} = \frac{-3.62 \times 10^{-5} (1 - 6.88 \times 10^{-6} h)^{-5.256}}{\frac{1}{2} S \rho_0} \quad \text{Eqn. 66}$$

Moving on, the derivative was taken of Eqn. 64 with respect to  $M_1$ .

$$\frac{dT}{dM_1} = E_T \beta^3 ((C_{D_o} + \beta^4 M_1^2 K)^{-1} - M_1 ((C_{D_o} + \beta^4 M_1^2 K)^{-2} (2KM_1 \beta^4))) \quad \text{Eqn. 67}$$

$$\frac{dT}{dM_1} = E_T \beta^3 (1 - (2KM_1^2 \beta^4)(C_{D_o} + \beta^4 M_1^2 K)^{-1}) \quad \text{Eqn. 68}$$

Eqn. 68 is a simplified version of Eqn. 67. The next step after taking the derivatives of Eqn. 63 and 64 is to reference Eqn. 69. For this equation to be true, either Eqn. 66 or Eqn. 68 or both need to be equal to zero. In order for Eqn. 66 to be equal to zero, the altitude must go to infinity.

$$\frac{dT}{dh} = \frac{dT}{dM_1} \frac{dM_1}{dh} = 0 \quad \text{Eqn. 69}$$

Then Eqn. 68 is set equal to zero in Eqn. 70.

$$0 = 1 - \frac{2KM_1^2 \beta^4}{C_{D_o} + \beta^4 M_1^2 K} \quad \text{Eqn. 70}$$

Through simplification, Eqn. 71 is found. Now, Eqn. 63 can be plugged in after Eqn. 9 is inserted. With these two substitutions, Eqn. 72 is found and the altitude can be solved for.

$$M_1 = \sqrt{\frac{C_{D_o}}{K\beta^4}} \quad \text{Eqn. 71}$$

$$\frac{1}{\frac{1}{2}\rho_o(1-6.88x10^{-6}h)^{4.256}S} = \sqrt{\frac{C_{D_o}}{K\beta^4}} \quad \text{Eqn. 72}$$

Eqn. 73 is the optimum altitude for the best endurance at an altitude that is below 36,000 feet.

$$h = \frac{1 - 4.256 \sqrt{\frac{1}{\frac{1}{2}\rho_o S} \sqrt{\frac{C_{D_o}}{K\beta^4}}}}{6.88x10^{-6}} \quad \text{Eqn. 73}$$

The next step is to determine the optimum altitude for the best endurance when the altitude is above 36,000 feet.

$$\rho_2 = .297\rho_o e^{-4.87x10^{-5}(h-36000)} \quad \text{Eqn. 10}$$

Eqn. 10 describes the change in density with altitude above 36,000 feet.

$$\beta = \frac{1}{v} \quad \text{Eqn. 74}$$

$$K = \frac{W^2}{\pi A e} \quad \text{Eqn. 75}$$

$$M_2(h) = \frac{1}{\frac{1}{2}\rho_1 S} \quad \text{Eqn. 76}$$

$$T = \frac{E_T}{\frac{1}{2}\rho v^3 S (C_{D_o} + \frac{1}{\pi A e} (\frac{W}{\frac{1}{2}\rho v^2 S})^2)} \quad \text{Eqn. 49}$$

In order to simplify the following calculations, Eqn. 74, 75, and 76 were used and plugged into Eqn. 49.

From this, Eqn. 77 was derived.

$$T = \frac{E_T \beta^3 M_2}{C_{D_o} + \beta^4 M_2^2 K} \quad \text{Eqn. 77}$$

To find the optimum altitude for the best endurance, the derivative must be taken of Eqn. 77 with respect to altitude (h). The best way to do this is to use Eqn. 78.

$$\frac{dT}{dh} = \frac{dR}{dM_2} \frac{dM_2}{dh} \quad \text{Eqn. 78}$$

By taking the derivative of Eqn. 76 with respect to h, Eqn. 79 was found.

$$\frac{dM_2}{dh} = \frac{3.27 \times 10^{-4} e^{4.87 \times 10^{-5}(h-36000)}}{\frac{1}{2}\rho_o S} = 0 \quad \text{Eqn. 79}$$

Then, the derivative of Eqn. 77 was taken with respect to  $M_2$ ; Eqn. 80 is derivative and Eqn. 81 is a simplification.

$$\frac{dT}{dM_2} = E_T \beta^3 ((C_{D_o} + \beta^4 M_2^2 K)^{-1} - M_2 ((C_{D_o} + \beta^4 M_2^2 K)^{-2} (2KM_2 \beta^4)) \quad \text{Eqn. 80}$$

$$\frac{dT}{dM_2} = E_T \beta^3 (1 - (2KM_2^2 \beta^4)(C_{D_o} + \beta^4 M_2^2 K)^{-1}) \quad \text{Eqn. 81}$$

In order to solve for the optimum altitude above 36,000 feet for the best endurance, derivative of Eqn. 77 was set equal to zero, in other words, Eqn. 78 set equal to zero.

$$\frac{dT}{dh} = \frac{dR}{dM_2} \frac{dM_2}{dh} = 0 \quad \text{Eqn. 82}$$

The altitude must go to negative infinity if Eqn. 79 is set equal to zero which is not physically possible for this problem. Therefore, Eqn. 81 is set equal to zero in Eqn. 83.

$$0 = 1 - \frac{2KM_2^2\beta^4}{C_{D_0} + \beta^4 M_2^2 K} \quad \text{Eqn. 83}$$

$$M_2 = \sqrt{\frac{C_{D_0}}{K\beta^4}} \quad \text{Eqn. 84}$$

Now, with Eqn. 84, Eqn. 76 can be substituted in along with Eqn. 10. Eqn. 85 is the substitution.

$$\frac{1}{\rho_0 S \frac{1}{2} (.297) e^{-4.87 \times 10^{-5} (h - 36000)}} = \sqrt{\frac{C_{D_0}}{K\beta^4}} \quad \text{Eqn. 85}$$

$$h = \frac{\ln\left(\frac{1}{\rho_0 (.149) \sqrt{\frac{C_{D_0}}{K\beta^4}}}\right) - 1.75}{-4.87 \times 10^{-5}} \quad \text{Eqn. 86}$$

Eqn. 86 is the optimum altitude for the best endurance at an altitude above 36,000 feet.

## 2.2 Derivation of Energy and Efficiency Equations for Electric and Electric Hybrid Airplanes

From public domain data much of the performance and design details of the fully electric airplanes could be determined that competed in the Green Flight Challenge. In order to find such performance data the following equations were necessary.

The total energy ( $E_T$ ) used for each of the two electric airplanes could be found by using the Passenger-mpg (PMPG), which was a measurement of the airplanes energy consumption for the flight. Knowing the number of passengers ( $p$ ) and the distance in miles ( $N$ ), the gallons of gas could be determined, then multiplying by the energy stored in one gallon of gasoline ( $e_{87}$ ) the total energy could be found.

$$E = \frac{pD}{PMPG} (e_{87}) \quad \text{Eqn. 87}$$

Eqn. 87 shows this process and once the total energy was known then the average motor power could be found:

$$HP_{ave} = E \frac{V_{ave}}{D} \quad \text{Eqn. 88}$$



From Eqn. 88, the average power ( $HP_{ave}$ ) used over the flight could be determined based upon the total stored energy onboard the airplane ( $E_T$ ), average speed flown for the competition ( $V_{ave}$ ), and the distance flown ( $N$ ). With the  $HP_{ave}$  known, the average aerodynamic efficiency ( $L/D$ ) could be determined at the average competition speed. Assuming level flight the Lift could be equated to the weight of the airplane ( $W$ ) which was known. Then the drag could be found by finding the force required to push the airplane through the air. The  $HP_{ave}$  is the power required and since the average velocity was also known, the force could be determined with the inefficiencies in the motor ( $\eta_m$ ) and the propeller ( $\eta_p$ ) included.

$$L/D = \frac{W}{\eta_p \eta_m \frac{HP_{ave}}{V_{ave}}} \quad \text{Eqn. 89}$$

Note in Eqn. 89 that as the efficiency increases the  $L/D$  can decrease. The less energy wasted the lower the efficiency of the airplane needs be; the lower the  $L/D$ .

The total energy required is the total energy used plus that of a 30 minute reserve required by the race rules. This reserve would have to last the entire half an hour at the average power used during the race. Since the total energy calculated above was an average for the entire course, simply multiplying by  $1\frac{1}{4}$  would yield the appropriate amount of energy required by the competition.

$$E_2 = E + \frac{1}{4}E \quad \text{Eqn. 90}$$

Eqn. 90 also represents the minimum energy that each of the teams had to have carried on board. The number of batteries, weight, and cost was estimated from public domain searches of available, high energy density batteries. Using a parabolic drag equation, the  $C_{D_o}$  could be determined (Oswald).

$$D = \frac{1}{2}\rho V^2 S C_{D_o} + \frac{2}{\rho \pi e} \left(\frac{b}{W}\right)^2 \left(\frac{1}{V^2}\right) \quad \text{Eqn. 91}$$

Eqn. 91 required an estimate of Oswald's efficiency for all of the airplanes. The wing span ( $b$ ), and the drag that was already determined in the  $L/D$  equation since  $L = W$  in cruising flight.

Rate of climb was determined by dividing the excess power which involves subtracting the amount of available power, which is the multiplication of the thrust ( $T$ ) and the velocity ( $V$ ), from the power required, which is the drag ( $D$ ) multiplied by the  $V$ . This excess power is then divided by the weight of the airplane ( $W$ )<sup>7</sup>.

$$R/C = \frac{TV - DV}{W} \quad \text{Eqn. 92}$$

Eqn. 92 is the general rate of climb equation comparing power available to the power required in order to get  $P_{excess}$ .

By increasing the weight, the L/D curve is shifted to the right along the velocity axis<sup>56</sup>.

$$V_s = \frac{1}{\sqrt{S}} \sqrt{\frac{W'}{W}} \quad \text{Eqn. 93}$$

$V_s$  is the vertical speed down, the sink speed or sink rate, and  $W'$  is the new weight of the glider. Eqn. 93 can be used to plot various speed polars for difference weights. As the weight increases the polar shifts to the right and down slightly making the best L/D appear at a higher velocity.

### **2.3 Equations Required for Comparing Electric Airplanes to Reciprocating Engine Airplanes**

Comparing electric airplanes to reciprocating engine airplanes requires several equations. These equations were used to find the drag of the original unmodified Stemme S10 in its gliding configuration based upon the speed polar. The drag on the airplane in its unmodified condition with the cooling doors and propeller extended was also determined using the following equations and the best rate of climb stated in the Pilot's Operating Handbook. The 'clean' case references the unmodified Stemme S10 in its gliding configuration which does not include the cooling doors or the propeller. The 'dirty' case includes the propeller and the cooling doors extended into the airflow. The unmodified Stemme S10 had the option of retracting the propeller and cooling doors for non-powered, gliding operations.

$$D = W * \tan\left(\frac{V_s}{V}\right) \quad \text{Eqn. 94}$$

Eqn. 94 is the basic drag Eqn. derived from the Speed Polar.

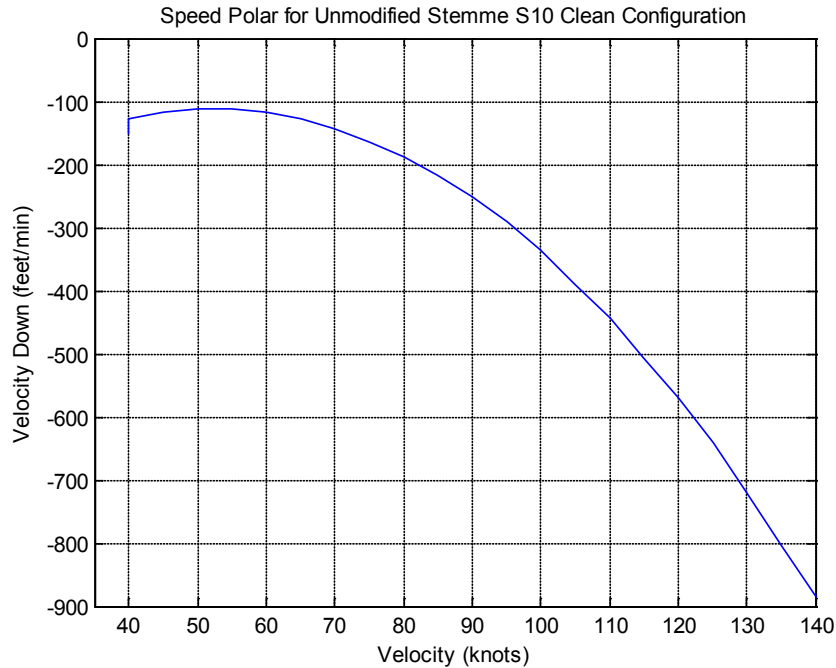

Figure 11: Speed Polar for Unmodified Stemme S10 Clean Configuration<sup>64</sup>

Figure 11 is the speed polar for the Stemme S10 at a weight of 1870 pounds. In relations to Eqn. 94  $V_s$  is along the y-axis and is the velocity down or the sink rate while the  $V$  is the horizontal velocity of the airplane. Eqn. 94 uses this graph that can be found in the Stemme S10 POH and find the drag for various airspeeds.

$$D_{Dirty} = D_{Clean} + \frac{1}{2} \rho V^2 S C_{D_o} + \frac{2}{\rho \pi e} \left(\frac{b}{W}\right)^2 \left(\frac{1}{V^2}\right) \quad \text{Eqn. 95}$$

Eqn. 95 helps determine the drag for the 'dirty' case. This equation can only be solved if Oswald's efficiency ( $e$ ) and the coefficient of drag at zero lift ( $C_{D_o}$ ) are known, which they are not, therefore an educated guess must be made. Referring to the Stemme S10 Pilot Operating Handbook, the maximum rate of climb is listed for a stated velocity<sup>64</sup>. This value will be necessary in finding an approximate guess for  $e$  and  $C_{D_o}$  but first the rate of climb for the clean configuration of the airplane must be plotted.

The classical R/C equation listed above in Equation 96 is required<sup>7</sup>.

$$R/C = \frac{TV - DV}{W} \quad \text{Eqn. 96}$$

With drag and weight known, the thrust, or power available, must be found. The original engine was a Limbach reciprocating engine that had a maximum of 89.5 Hp, however the propeller was a fixed pitch two blade propeller that was extremely inefficient. In order to approximate the inefficiencies of the propeller first the coefficient of power needed to be found<sup>64</sup>. One method in order to determine the

propeller efficiency was to find the ratio of the power converted to propulsive force to the power produced by the engine<sup>7</sup>.

$$\eta_p = J \frac{C_T}{C_p} \quad \text{Eqn. 97}$$

Using the basic definitions of  $C_T$  and  $C_p$  and knowing the definition of the advance ratio ( $J$ ) then the propeller efficiency could be found for various speeds<sup>7</sup>.

$$J = \frac{V}{nd} \quad \text{Eqn. 98}$$

$$C_p = \frac{P}{\rho n^3 d^5} \quad \text{Eqn. 99}$$

$$C_T = \frac{T}{\rho n^2 d^4} \quad \text{Eqn. 100}$$

Then knowing the propeller efficiency for various airspeeds the power available ( $P_{avail}$ ) could be determined. Using Eqn. 50 the  $P_{req}$  for 'dirty' flight could be found and used in conjunction with the  $P_{avail}$  to find the rate of climb of the airplane using Eqn. 96. For the 'dirty' case the rate of climb including for the clean configuration the rate of climb stated in the Pilot Operating Handbook for a particular speed was then plotted (Figure 11). The graph clearly shows that for that particular speed the speed polar gives a rate of climb that is much higher for the clean case. This difference is drag due to the cooling doors and the propeller and can be estimated using the parabolic drag Eqn. and the rate of climb Eqn. in conjunction. Since the drag of the entire airplane is desired, the drag can be estimated using Eqn. 95. Oswald's efficiency and the  $C_{Do}$  can be estimated by returning to the R/C graph and changing both parameters until the curve matches the rate of climb curve plotted from the speed polar and passes through the rate of climb point stated by the Pilot's Operating Handbook for the Stemme S10.

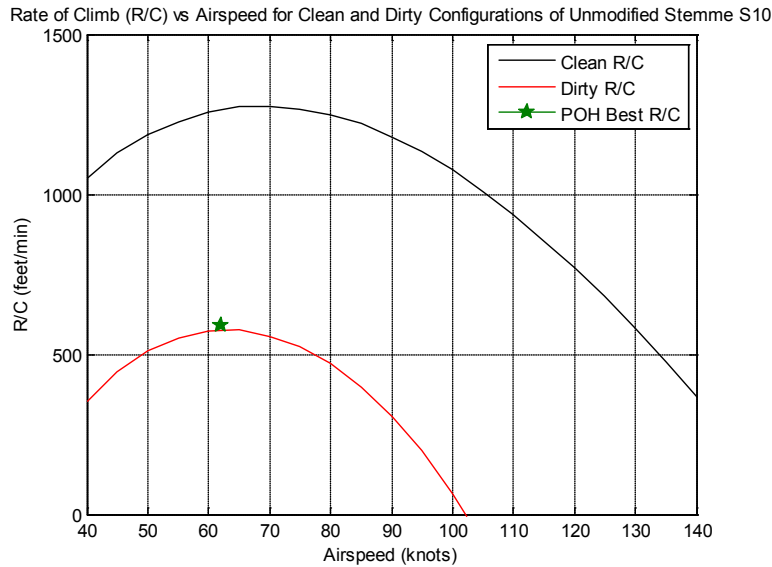

Figure 12: Rate of Climb vs Velocity for Clean and Dirty case of the Original Configuration of the Stemme S10

Figure 12 shows the R/C for the ‘dirty’ and ‘clean’ cases of the Stemme S10. The bottom curve was shaped using  $e$  and  $C_{do}$  in order to determine rough estimates for the values. Careful manipulation of the two parameters matched the shape and sent the ‘dirty’ curve through the R/C stated in the POH. Since the airplane climbs at a maximum R/C of 650 feet per minute at 62 knots the ‘dirty’ case had to include that point at the apex of the curve.

Converting a production airframe from an internally combustion propelled airplane to an electrically powered airplane could be a solution for many people wanting to use electric power. The first step would be to find the empty weight of the airplane and subtract that from the gross weight.

$$W_{batt} = W_i - W_{empty} - p(200) - W_{motor} + W_{engine} + W_{fuel\ tanks} \quad \text{Eqn. 101}$$

Eqn. 59) determines the weight in batteries that the airplane could carry without violating the maximum gross weight. This equation subtracts the empty weight of the airplane ( $W_{empty}$ ), the number of passengers multiplied by 200 pounds per passenger, the motor weight from the weight of the removed engine from the maximum gross weight of the airplane. Also added back in is the weight of the fuel tanks if they can be removed. Knowing the weight of batteries that can be installed is necessary in order to know how much energy could be stored on board the airplane. As a note  $W_{empty}$  includes the weight of the fuel tanks and  $W_{engine}$  includes all of the accessories that go along with the engine.

Assuming a battery from public domain data, the energy that could be stored on board can be found.

$$Total\ Stored\ Energy = BatteryWeight(Energy\ Density\ of\ Battery) \quad \text{Eqn. 102}$$

With the energy density in units of HP-hr/lb the HP-hr, or energy can be determined. This energy is not the only value necessary in determining the range or endurance of the airplane.

## Chapter 3 Analysis and Results

### 3.1 Electric Airplane Flight Profile

The most efficient flight profile of an electric airplane may not match that of an internal combustion engine as noted by the Pathfinder and Helios airplanes<sup>42</sup>. In order to determine the optimum velocity and altitude for the best endurance and range of the electric airplane the equations derived in Chapter 2 must be used.

In examining the electric airplane the flight profile is an important topic of discussion because the standard Brequet Range equation for reciprocating internal combustion engine airplanes does not apply since weight of the airplane does not change over the flight profile. Eqn. 1 is the classic Brequet Range equation<sup>7</sup>.

$$R = -\frac{\eta_p \left(\frac{L}{D}\right)}{SFC_p} \int_{W_1}^{W_2} \frac{dW}{W} \quad \text{Eqn. 1 (3.59)}$$

$W_1$  is the original weight of the airplane including full fuel, full payload and crew and  $W_2$  is the same weight minus the weight of the fuel. This equation demonstrates that in order to have a longer range the specific fuel consumption with regards to power ( $SFC_p$ ), and the drag ( $D$ ) must be as low as possible. Altitude is an integral part of  $SFC_T$ , as altitude increases, so does  $SFC_p$  which means that the range would decrease, therefore, lower altitudes are ideal for better range when dealing with internal combustion airplanes. The other variable that can change the range is airspeed. A higher velocity means a higher range, however, drag is related to velocity and in order to obtain the best range the drag needs to be reduced. The least drag occurs when the  $L/D$  is the highest which means there is a particular velocity for this case.

For fully electric airplanes the weight does not change because battery weight does not change with discharge. Electric airplanes there is no fuel burn and thus no change in weight from takeoff to landing which means that the value for Range would be zero. Both Pipistrel and EGenius did in fact fly the Green Flight Challenge 200 mile course which meant that the range could not be zero and that this Eqn. is not valid for electric airplanes<sup>7</sup>.

$$T = \frac{\eta_p^{EMP}}{SFC_p V_{MP}} \ln\left(\frac{W_1}{W_2}\right) \quad \text{Eqn. 47}$$

Eqn. 47 is the standard endurance equation for propeller driven aircraft. The most important variable in this equation is the weight fraction burned in flight. This value means that there was a weight change during the course of the flight, but for electric airplanes there is no weight change. The natural log of 1

is zero and this equation states that the endurance for electric airplanes is zero. In order to find the range and endurance of the fully electric airplane the basic definitions of both must be revisited.

Chapter 2 tracks through the equations starting with the most basic range Eqn. 2 and uses the relationships expressed in Eqn. 3, 4, 5, 6, and 7 in order to get an Eqn. 8 that has two variables that affect it, altitude and velocity.

$$R_e = \frac{E_T}{\frac{1}{2}\rho V^2 S (C_{D_0} + \frac{1}{\pi A e} (\frac{W}{\frac{1}{2}\rho V^2 S})^2)} \quad \text{Eqn. 8}$$

For the case with altitude, since the density is a function of altitude two cases were examined, one where the altitude was below 36,000 feet and one that was above. Since altitude is a function of density and the optimum altitude is being researched, these equations relating the two were used.

Both Eqn. 25 and Eqn. 33 show that in order to obtain the best Range for an electric airplane the altitude must be at 36,000 feet since that is where it is bounded to. Physically this means that the airplane must fly as high as possible in order to obtain the best range. Then, Eqn. 22 can only be true if the altitude goes to infinity. These answers are both against what the altitude should be for conventional internal combustion engines; since internal combustion engines rely on air in order to ignite the gas and move the pistons which in turn provide power to the propeller the higher the energy density, the better the use of gasoline and the longer the range can be. Electric motors, however, do not require air in order to generate power. The higher the electric airplane travels the more efficient it becomes because there is less resistance that the propeller and plane experience.

$$0 = 1 - 6.88 \times 10^{-6} h \quad \text{Eqn. 17}$$

$$e^{-4.87 \times 10^{-5} h} = 0 \quad \text{Eqn. 22}$$

Does the infinite altitude for maximum range make sense? Yes, less drag. Is it practical? No, climbing requires energy, there are altitude restrictions on airplanes, and infinity is very far.

Then, the optimum velocity for range was found in Eqn. 27 and the optimum velocity. Using known airplanes, required data for solving Eqn. 27 was input into Table 7 in order to determine if the optimum velocity equation made sense.



Table 8: Check of several airplanes to optimum velocity equation for best range<sup>(16, 19, 55, 60, 64)</sup>

Airplane	Weight (lbs)	Wing Area (ft <sup>2</sup> )	Aspect Ratio (A)	C <sub>D0</sub>	Computed Velocity (kts)	V <sub>best glide</sub> (kts)
Pipistrel	3290.8	200	24	0.0186	65	57
EGenius	2070.2	132.7	22	0.016	67	57
Stemme S10	2370	201	29	.02	53	57
PhoEnix	1320	138.5	17	.025	52	55
Cessna 172	2450	174	7.5	.035	70	65
DA 20	1764	125	10	.03	68	73

Table 8 displays the same airplanes that were listed in Table 7 and compares their computed velocity using Eqn. 22.

$$v = \sqrt{\frac{2}{\rho S \sqrt{\frac{C_D}{W^2} \pi A e}}} \quad \text{Eqn. 22}$$

The farthest most right column has the 'velocity for best glide' (V<sub>best glide</sub>). The velocity for best glide is the speed at which the highest L/D is obtained, at this airspeed the drag is at a minimum and in order to travel as far as possible the drag must be as low as possible.

Then, moving on to endurance, Eqn. 30 was found as the basic endurance equation. The optimum altitude was derived in much the same way that it was for range and the results, given the two cases of density varying with altitude above and below 36,000 feet, were found in Eqn. 36 and Eqn. 39. Eqn. 36 has a singularity at 145,000 feet but this equation was bounded to 36,000 feet which physically means that the altitude should be above 36,000 feet. Eqn. 39 can only be true if the altitude goes to infinity.

$$End = \frac{E_T}{\frac{1}{2} \rho v^3 S (C_{D0} + \frac{1}{\pi A e} (\frac{W}{\frac{1}{2} \rho v^2 S})^2)} \quad \text{Eqn. 30}$$

$$h = \frac{1 - 4.256 \sqrt{\frac{1}{\frac{1}{2} \rho_0 S \sqrt{\frac{C_{D0}}{K \beta^4}}}}}{6.88 \times 10^{-6}} \quad \text{Eqn. 73}$$

$$h = \frac{\ln\left(\frac{1}{\rho_0 (.149 \sqrt{\frac{C_{D0}}{K \beta^4}})}\right) - 1.75}{-4.87 \times 10^{-5}} \quad \text{Eqn. 86}$$

Eqn. 73 and Eqn. 86 state that the altitude needs to be as high as possible in order to maximize the endurance of the electric airplane. These two equations give actual values but Eqn. 73 is bounded to 36,000 feet and the altitudes this equation gives are much higher than 36,000 feet. Eqn. 86 gives an answer as well but for normal generated airplanes, the altitudes would place the airplane in the mesosphere. Therefore, the airplane should fly as high as reasonably possible. Energy required to climb to altitude and duration of the leg need to be considered.

Eqn. 60 was then derived which is the optimum airspeed for an electric airplane in order to maximize the endurance. In order to quantify and validate this equation a comparison was made between several different airplanes. Table 8 lists several different airplanes and their computed velocity from Eqn. 60 along with their stall speed.

*Table 9: Several airplanes analyzed to check optimum velocity for the best endurance<sup>(16, 19, 55, 60, 64)</sup>*

Airplane	Weight (lbs)	Wing Area (ft <sup>2</sup> )	Aspect Ratio (A)	C <sub>Do</sub>	Computed Velocity (kts)	Stall Speed (kts)
Pipistrel	3290.8	200	24	0.0186	51	45
EGenius	2070.2	132.7	24	0.016	52	45
Stemme S10	2370	201	29	.015	40	45
PhoEnix	1320	138.5	17	.02	41	47
Cessna 172	2450	174	7.5	.05	50	52
DA 20	1764	125	10	.04	50	52

Table 9 above depicts several different airplanes and their basic numbers in order to find the optimum velocity for the best endurance. Eqn. 60 was used in order to calculate the ‘computed velocity.’ Altitude was set at sea level for all airplanes.

$$v^4 = \frac{1}{\frac{3C_{D_0}}{M^2 K}} \quad \text{Eqn. 60}$$

The batteries have only so much power and in order to stay up the longest the batteries would need to be drained as slowly as possible. The faster the airplane goes the quicker the energy is drained and the shorter the flight time.

Disregarding the power to climb to altitude, the flight profile should be as high as possible and the velocity for the best endurance should be near stall speed while the velocity for best range should be near the best L/D speed.

Now, if Eqn. 30 is examined once again, the basic variable is time which is a function of energy usage. The faster the energy is burned the less time there will be. The best way to maximize the endurance is to limit the energy usage which means to fly as slowly as possible. Table 6 depicts the velocity for best endurance to be the stall speed.

### 3.2 The Current State of the Electric Airplane

The results published by CAFE (Comparative Aircraft Flight Efficiency), the third party organization that NASA contracted to run the Green Flight Challenge are listed in Tables 6 and 7. This information, while limited, is the first of its kind that can truly map what the two electric planes did quantitatively.

*Table 10: Battery Information and Assumed Values for Analysis<sup>68</sup>*

ThunderPower TP7800	0.1 hp-hr/lb 2.32 lb \$320.00 per unit
Assumed average propeller efficiency ( $\eta_p$ )	85%
Assumed electric motor efficiency ( $\eta_m$ )	92%
Oswald's efficiency factor (e)	0.90

A ThunderPower TP7800 was chosen as a representative public domain battery<sup>68</sup>. This battery is a Li-Ion battery and is a good estimate of the battery used by both the Pipistrel and EGenius airplanes. Assumed values of the propeller efficiency ( $\eta_p$ ), motor efficiencies ( $\eta_m$ ), and Oswald's efficiency factor were kept constant through the following analysis.

The assumed  $\eta_p$  can range in value depending upon airspeed and pitch. EGenius had a constant speed or variable pitch propeller that could change pitch in order to increase efficiency. Pipistrel had a fixed pitch propeller that was specially designed for the flight profile of the GFC competition. For optimally designed propellers the efficiency is normally between 85% and 90%<sup>40</sup>. Since an average for the entire flight is of interest, the propeller efficiency was assumed at 85% in order to cover the various portions of flight.

The assumed  $\eta_m$  was defined with an efficiency value of 92% based upon standards provided by the National Electrical Manufacturers Association (NEMA)<sup>44</sup>. NEMA provides, among other standards, minimum efficiency values for various power electric motors. According to NEMA, motors with a maximum power output between 50HP and 99HP must be at least 90.7% efficient and electric motors with a maximum power output great than 125HP must be at least 93% efficient. EGenius had a

maximum power output from their motor of 80.4 HP and Pipistrel had a maximum power output of 194. Therefore, 92% was chosen as an average value.

Oswald’s efficiency factor accounts for the induced drag<sup>40</sup>. According to McCormick values of Oswald’s efficiency factor vary based upon high wing and low wing airplanes due to the interaction of the thick boundary layer on the top of the wing and the fuselage. For high wing airplanes the upper boundary layer is not disturbed by the fuselage permitting values for  $e$  to be as around 0.80. For low wing airplanes the fuselage boundary layer interacts with the upper wing boundary layer and can lower  $e$  to around 0.60. That value of 0.90 was chosen due to the glider-like designs of the Pipistrel and EGenius airplanes. Both have high aspect ratio and laminar airfoil wings and have long wing span and based upon the definition of Oswald’s efficiency factor, the value should be higher for such airplanes.

From the public domain data and the assumption of several key parameters the following performance was determined for the two fully electric airplanes listed in Table 11. Eqn. 89 through 92 were used.

*Table 11: Computed Performance for the Fully Electric Airplanes*

	Pipistrel	E-Genius
Total Energy Used	89.6 HP-hr	48.1 HP-hr
Average Motor Input Power	50.9 HP	25.8 HP
Shaft HP	46.9 HP	23.8 HP
Total Energy Storage Required w/reserve	112 HP-hr	60.1 HP-hr
Battery Weight	1118.9 lb	600.7 lb
Battery Cost	\$154,337.80	\$82,857.00
Average Drag (GFC Speed ( $V_{ave}$ ))	131.3 lb	70.5 lb
Average L/D	25.1	29.4
Computed $C_{Do}$	0.0186	0.016
Compute Max R/C	1434.6 ft/min	869.9 ft/min
Airframe Weight Fraction	47%	58%
Battery Weight Fraction	44%	35%
Percent Power on Course	26%	32%

The results in Table 11 show the current state of technology for a fully electric airplane and might help to explain why each of the companies chose the designs and configurations that they did. This table suggests that the propulsion system is only part of the equation in order to design an efficient electric airplane. The Average Competition Speed was determined by the distance of the Green Flight Challenge competition course and the time it took each competitor to complete the course. As listed in Table 6 Pipistrel flew the course with an average GFC speed of 113.7 mph and EGenius flew, as listed in Table 7, the course with an average GFC speed of 107.3 mph.

First, the percent power on course is surprisingly low for both aircraft. In the case of the Cessna 172, as a point of reference, 75% power is usually seen when the aircraft is in its nominal cruising portion of flight. So why is the percent power on course so low for the Pipistrel and EGenius electric planes? The weight is high. If the battery weight were much lower than the power required to climb would be far less.

This only explains why the motor was sized as large as it was. When the airplane reached level cruising conditions power was reduced as is traditional but the reason that the power was brought back as far as it was had to do with the aerodynamic efficiency of the planes. The L/D on both airplanes was extremely high for the speeds they were flying at. A trick to increase L/D that many glider pilots use in cross country competitions is to increase the weight of the airplane<sup>56</sup>.

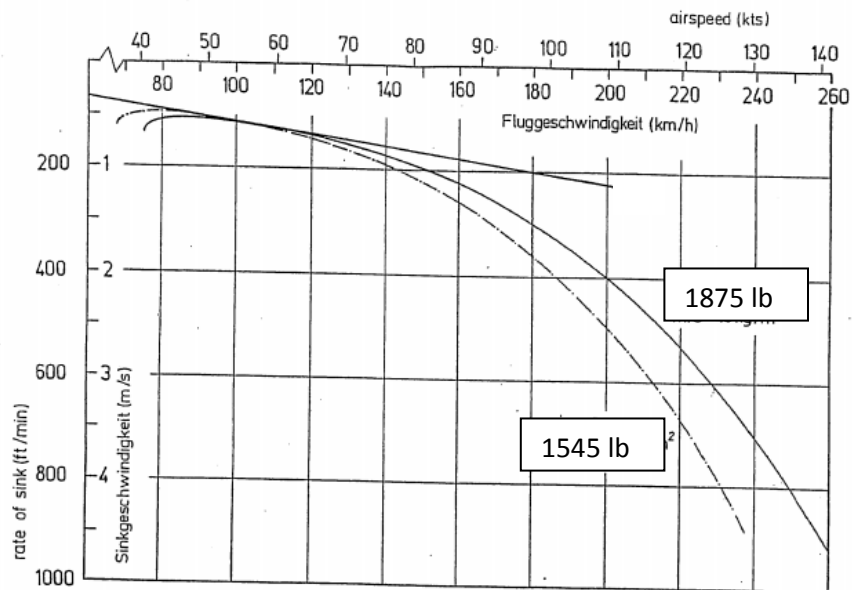

Figure 13: Speed Polar Shifted due to Weight change<sup>64</sup>

Figure 13 clearly shows how the increased weight affects the speed polar and thus the Lift to Drag for the vehicle<sup>56</sup>. Eqn. 52 defines Figure 13 where  $W'$  is the new weight of the airplane and  $W$  is the weight defined by the speed polar.  $S$  is wing plan-form area and  $V_s$  is the rate of sink, or vertical speed down. The horizontal airspeed of the airplane is plotted against the new rate of sink in order to obtain the new speed polar. Drawing a line from 0 rate of sink and 0 forward velocity (airspeed), the new airspeed for best L/D can be found.

$$V_s = \frac{1}{\sqrt{S}} \sqrt{\frac{W'}{W}} \quad \text{Eqn. 52}$$

This weight increase acts to shift the best L/D to a faster airspeed, however, increased airspeed increases parasite drag and increased weight increases induced drag<sup>56</sup>. However, as the L/D increases the change in weight does not drastically affect the power required. The higher the L/D of the airplane the less the weight increase hurts the power required.

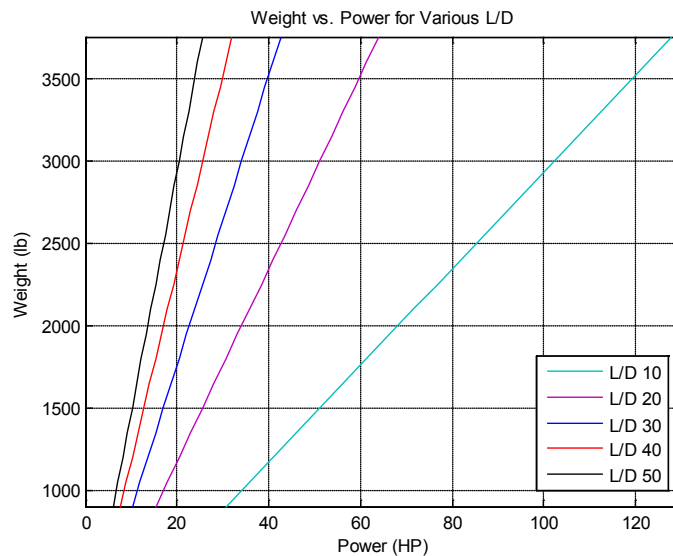

Figure 14: Weight vs. L/D and the Required Power

Figure 14 shows the relationship between weight, L/D and power for cruise. This figure is governed by Eqn. 48 and helps demonstrate the concept raised above regarding the interrelation of these three variables.

Increasing the weight does push the maximum L/D to a higher velocity, but it also requires more energy. Another drawback of increasing the weight involves increasing the energy required to bring the airplane up to altitude. The higher the L/D of the airplane the less increased weight affects the power required. The effects at altitude of increased weight are much smaller than those required to climb. Remembering the potential energy equation, mass is a large portion of the energy required to increase the altitude of an object.

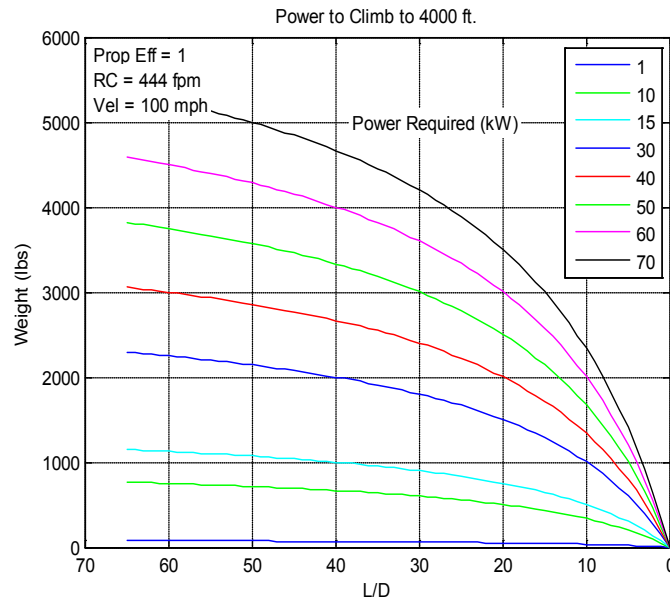

Figure 15: Weight vs. L/D for various power settings while climbing at 444 fpm

Figure 15 depicts the energy required for an airplane to climb to 4000 feet at a rate of climb of 444 fpm with an airspeed of 100 mph. This shows that even for high L/D the power required to climb can be quite high.

There are also structural considerations that need to be examined. Both airplanes were made of composite materials that behave and transmit loads much differently than metal airplanes. Composite airplane wing structures are completely different than metal ones. In the traditional metal structured wing there are metal ribs down the length of the wing with a thin metal skin attached to the ribs via rivets. Loads are transmitted through the ribs to the spar. Composite wings for most general aviation airplanes are monocoque structures that transmit load through the skin of the composite wing to the spar. With a composite wing, batteries can be placed and stored inside the wing and easily removed through an end cap. In the case of the metal wings the skin is usually too thin to transmit the loads to the ribs but if it were strong enough or if a case were created in the wings the only access point would be to drill out the rivets and peel back the skin. Large panels allowing access to the batteries would increase the weight and might create large stress concentrations that might be extremely unfavorable.

Assuming that the panels did not cause failure points and the mount for the batteries was made in the wings that allowed loads to be transmitted to the ribs, metal structures would be ruled out for one very important reason; laminar flow.

Laminar flow airfoils are only possible for composite airplanes that have extremely reduced skin friction drag. Increasing the laminar boundary layer as much as possible decreases the drag and in the efficiency game, drag is the name. The more drag a plane produces the more energy is required to push the airplane through the air.

The Pilot Operating Handbook for the Stemme S10 forbids takeoffs if the wings are wet or in rainy conditions<sup>64</sup>. This reason is because the rain water will trip the boundary layer and could create detached flow making the ailerons partially unusable, laminar bubbles.

Composite wings, in comparison to the metallic or fabric wings, are extremely rigid and do not deform with air pressure. Along with laminar airfoils, both fully electric Green Flight Challenge airplanes had aspect ratios that were much higher than the conventional airplane. Higher aspect ratio means less induced drag but higher bending moments.

Another reason to place the batteries in the wings is to help reduce the wing root bending moments. Clearly, increasing the load in the wings too much can cause bending moments in the opposite direction that would be too high. Knowing that the bending moments are larger for higher aspect ratio wings and that battery weight in the fuselage alone would cause even higher bending moments, placing batteries in the wings would prove to be a good idea to help offset such moments.

Landing gear is another area that can create a lot of drag which is one of the reasons gliders have only a wheel or two mounted to the fuselage. Both Pipistrel and EGenius chose short landing gear configurations that could easily be pulled up into the fuselage. Anything out in the airflow is a drag penalty and an automatic increase in the power required.

An airplane with short landing gear, however, gains a propeller clearance problem. In the terms of EGenius, a propeller on the nose would mean that the diameter would have to be exceptionally small and would quite possibly not generate enough power. Higher aspect ratio propellers reduce the drag of the propeller but increased area helps to provide more thrust. EGenius chose a higher aspect ratio propeller that they could change the pitch of in order to make up for the area and power reduction. Pipistrel, on the other hand, chose a large diameter propeller but with a reduced aspect ratio in order to generate a large amount of power for takeoff and climb out. Both airplanes chose propeller diameters that were larger than 6 feet and with small landing gear they were forced to find a solution to where they should place their propeller. EGenius chose to place the propeller on the tail while Pipistrel chose



to create a center fuselage between their two passenger carrying fuselages that sat high enough off the ground.

Another reason for the location of the propeller on the tail for EGenius was to have laminar air flow over the fuselage and inboard sections of the wings. A propeller creates a lot of turbulence and by placing it on the tail EGenius is actually making the rudder more effective and allowing the laminar flow over the fuselage thus further reducing the drag. One concern of this configuration is the structure of the tail with repeated landings.

Returning to the idea of an efficient airplane the question becomes, which is more important; increasing the L/D or the efficiency of the propulsion system?

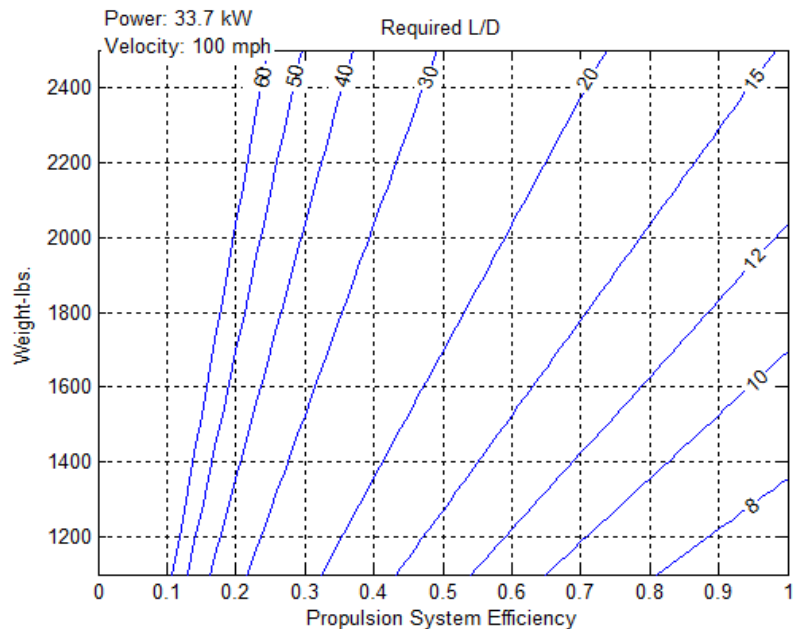

Figure 16: Weight vs. Propulsive Efficiency and the Required L/D

Figure 16 is governed by Eqn. 48 but now the power is held constant as opposed to the propulsive efficiency in Figure 14. This figure shows that as the L/D increases the change in weight does not increase the propulsive efficiency as much as with lower L/D's. With an L/D of 12 an increase of 600 pounds requires an increase in propulsive efficiency of 30%. However, with an L/D of 50 and a 600 pound weight increase, the airplane only requires an increase in propulsive efficiency of about 7%. Aerodynamic efficiency is demonstrated as being extremely important in airplane design, especially electric airplane design where weight is a problem. The answer to the question according to this figure

is that L/D can make a big difference and that an electric airplane design is also greatly interested in the aerodynamics.

### 3.3: Measuring Actual Electricity Used at the Green Flight Challenge

In analyzing both fully electric airplanes an area to note of significant importance is the energy measured by the CAFE Foundation during the GFC competition. According to the results published by the CAFE Foundation, both airplanes flew unprecedented passenger-mpg flights however their energy was only measured between the batteries and the motor. Before the flights, a shunt was placed between the batteries and motor and measured the voltage and current being transferred to the motor.

$$E_T(t) = \int_0^t i(\tau)\vartheta(\tau)d\tau$$

Eqn. 61

Eqn. 61 is a sample calculation for the method used in order to calculate the energy used to propel the airplane during and for the competition.  $E_T$  is the total energy used for the GFC competition flight,  $i$  is the current and  $\vartheta$  is the voltage. The total energy was found by integrating the current and voltage at the instantaneous time ( $\tau$ ) over the total time of the flight ( $t$ ).

This equation does not take into account the entire electrical system associated with the two electric airplanes. As expected with any system there are inefficiencies when all of the components are included. If the energy was measured from the outlet, as was defined by the original rules, would Pipistrel and EGenius still have met the 200 passenger-mpg requirements?

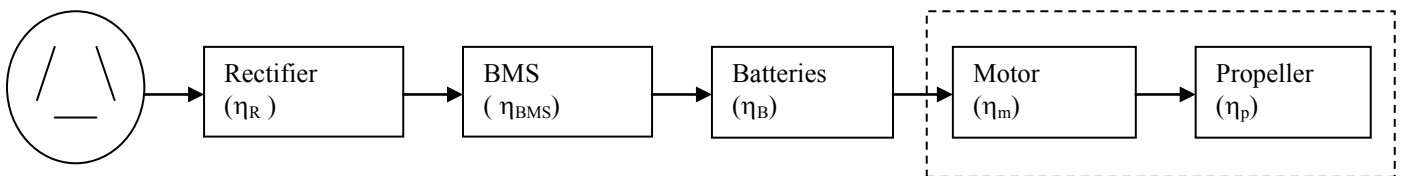

Figure 17: The flow of electricity from the outlet on the far left all the way to the propeller on the far right with efficiencies included

Figure 17 above depicts the flow of electricity from the outlet on the far left through the various components to the propeller, on the right. The rectifier acts to transfer power from normal AC to DC in order to charge the batteries. The BMS (Battery Management System) monitors and manages the current and voltage transmitted to the batteries in order to ensure the batteries are not damaged. Battery Management Systems can be extremely inefficient since the balancing of cells can be quite complicated and require the bleeding of excess voltage and current to resistors as the batteries near

their fully charged states. Battery systems themselves can dissipate energy in the form of heat thus making them slightly inefficient and the same can be said of the electric motor. Finally the propeller efficiency can be slightly better for a variable pitch or constant speed propeller, however, propeller efficiencies are normally no better than 85%.

The dashed area in Figure 15 was the only area that the CAFÉ Foundation measured current and voltage flow through. Before the start of the competition an ‘energy totalizer’ was installed into each of the airplanes and attached to small laptops that were placed in the cockpits. This laptop recorded the amount of energy transmitted from the batteries to the motor and propeller which disregarded the fact that the Battery system, the BMS, and the Rectifier all had inefficiencies stacked up in them.

*Table 12: Total passenger-mpg measured using stacked inefficiencies <sup>(1, 60)</sup>*

		Rectifier Efficiency (%)	BMS Efficiency (%)	Battery Efficiency (%)	Recorded Passenger-mpg	Calculated Passenger-mpg
Pipistrel	Best Case	99	90	90	403.5	323.6
	Worst Case	97	70	80	403.5	219.2
EGenius	Best Case	99	90	90	375.8	301.3
	Worst Case	97	70	80	375.8	204.1

Table 12 demonstrates that if the entire system had been included in the determination of the passenger-mpg; if the electricity used had been measured from the outlet, the results would have been different. The efficiency values chosen for the rectifier, BMS, and batteries have listed a best case and a worst case. These efficiency values were estimated since actual data was limited for each. The new calculated passenger-mpg calculated can now be compared to the recorded value. This table states that both airplanes would have still met the passenger-mpg requirement for the competition but their values would have been greatly reduced.

### **3.4 Comparison Between Electric and Internal Combustion Engine Airplanes**

By comparing internal combustion engine airplanes to fully electric airplanes the differences between them become more evident. Aerodynamics plays an extremely important role in the power required by the airplane, therefore, a clean example needs to be made. The Pipistrel and EGenius fully electric airplanes were compared to copies of themselves except with the batteries and motor removed and an internal combustion and gasoline added. This comparison assumed constant L/D, therefore, nothing, apart from the propulsion system was changed.

Table 13: Pipistrel Comparison to Equivalent Internal Combustion Engine Airplane at Constant L/D <sup>60</sup>

	Electric	Internal Combustion
Battery Weight	1118.9 lb	N/A
Engine Weight	200 lb	200 lb
Gasoline Weight	N/A	30.1 lb
Equivalent Flight Weights	3294.1 lb	2171.9 lb
Fuel Flow	N/A	2.0 gal/hr
Total Energy Used	89.6 HP-hr	226 HP-hr
Average Motor Input Power	50.9 HP	128.5 HP
Shaft HP	46.9 HP	41.1 HP
Passenger-MPG	403.5	160

Table 14: EGenius Comparison to Equivalent Internal Combustion Engine Airplane at Constant L/D <sup>60</sup>

	Electric	Internal Combustion
Battery Weight	600.7 lb	N/A
Engine Weight	100 lb	200 lb
Gasoline Weight	N/A	17.8 lb
Equivalent Flight Weights	2070.2 lb	1469.5 lb
Fuel Flow	N/A	1.18 gal/hr
Total Energy Used	48.1 HP-hr	133.3 HP-hr
Average Motor Input Power	25.8 HP	71.6 HP
Shaft HP	23.8 HP	22.9 HP
Passenger-MPG	375.8	135.6

Tables 13 and 14 demonstrate what would happen if the L/D were to remain constant between the fully electric Pipistrel or EGenius planes as compared to reciprocating engine versions. Data used to determine these tables was taken from tables 6, 7, and 8.

In this comparison the aerodynamics were assumed to be the same and the motor efficiency was reduced from 0.92 to 0.34 for the gas engine. In addition, the airplane weights were changed; the weight of the batteries was removed and the weight of the fuel was added. The assumption was made that the weight change from motor to gas engine was negligible for Pipistrel but was an increase of 100 pounds to the internal combustion engine for EGenius.

Using the basic Eqn.s from Chapter 2, a comparison could be made between the Pipistrel and EGenius airplanes by inserting an internal combustion engines. For both cases the L/D was assumed to be constant, in other words the aerodynamics of both airplanes was the same between the fully electric

and now internal combustion engine with only the engine and power sources changed. However, such a statement is not possible and is even expressed in Tables 9 and 10. Reciprocating engines are far less efficient than electric motors due to the energy lost as heat. The difference between the shaft horsepower and the average motor input power between the two power plants is a loss in energy. Electric motor efficiencies are somewhere in the 90 percentile area where as internal combustion engines are in the 30 percentile range. Why the difference in the efficiency; heat.

Reciprocating engines lose most of their energy in the form of heat which means that these forms of power generation systems are far hotter than electrical motors. Heat can be a very big problem for metal engine components and composite structures that encase the metal. In order to reduce the heat most reciprocating engines require cooling in the form of air, which infers that ducts are necessary. These cooling ducts automatically increase the drag especially on airplanes that have minimal drag to start with. If the drag is increased on the internal combustion engine airplane, than the L/D cannot be constant between the two cases. Internal combustion engine airplanes take a double penalty in losing roughly 70% of the energy stored in the fluid to heat and then in order to cool the heated engine, another penalty must be taken due to the aerodynamic losses of introducing cooling ducts.

As an example of cooling drag, the unmodified Stemme S10 has an L/D of 51:1 at an airspeed of 57 knots (66 mph) when the propeller and cooling doors are retracted. However, when the cooling doors are extended the L/D drops substantially.

As a mode of comparison the unmodified Stemme S10 has cooling doors and a propeller that are closed and removed from the slip stream in gliding operations but are opened during the powered mode of flight. The difference these doors and propeller make are quite substantial. Using Eqn. 48) through 54) the difference in the drag could be determined and plotted.

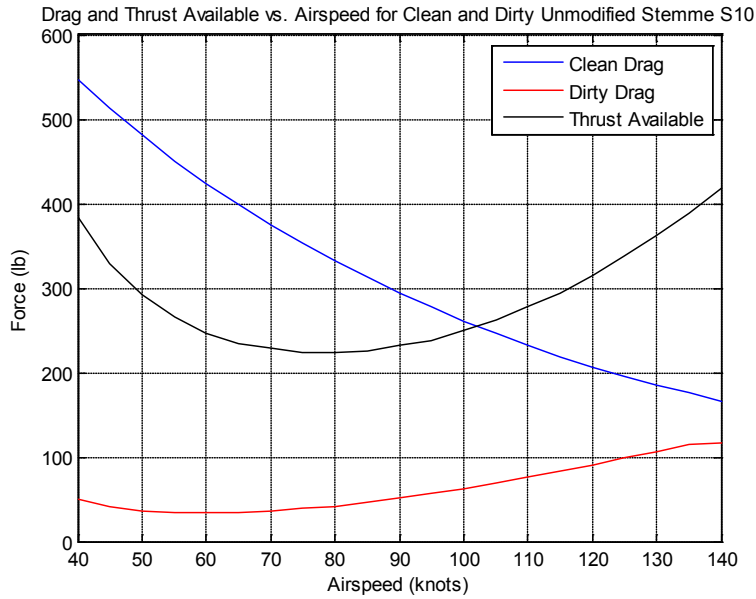
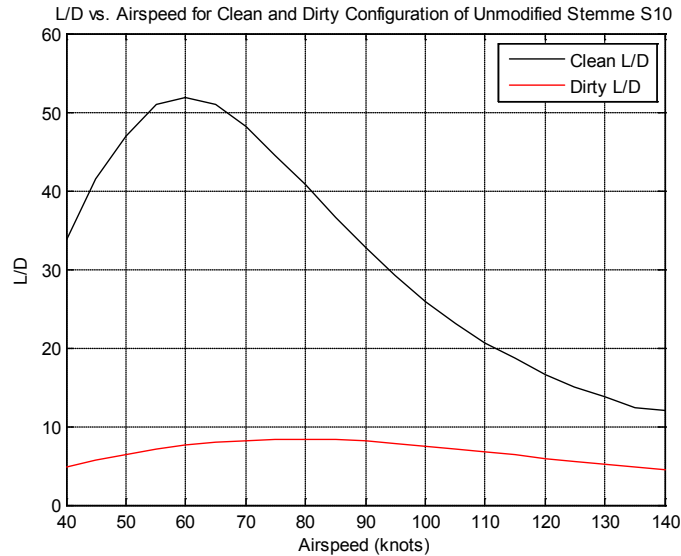

Figure 18: Drag vs. Velocity for the Unmodified Stemme S10 for 'clean' and 'dirty' flight operations

Figure 18 shows the difference between the two modes of flight for the unmodified Stemme S10. The clean case was derived from the speed polar for the airplane in its gliding configuration and the dirty case has the cooling doors and propeller extended into the slipstream.

The power required for both the clean and dirty modes of operation for the Stemme S10 are based upon the drag. Figure 18 shows the difference between the two cases and the curve for the power available. This figure clearly defines the case without cooling drag and propeller to the one with and shows the large difference in power.



*Figure 19: Power Available and Power Required for the 'clean' and 'dirty' conditions of the unmodified Stemme S10 motor-glider*

Figure 19 shows the large difference that the propeller and cooling doors can make on the unmodified Stemme S10. With the propeller and cooling doors folded the gliding ratio substantially increases. Since the drag without the cooling doors and propeller is extremely low the cooling doors and propeller substantially affect the overall drag of the airplane.

Figure 11 in Chapter 2 is the speed -polar of the unmodified Stemme S10 in the gliding portion of operations; no cooling doors and no propeller. Using this curve and knowing the weight of the airplane used to determine the speed polar (as mentioned above the speed polar shifts with added or subtracted weight) Eqn. 48 will provide the drag for various velocities. This, however, is only the drag of the “clean” airplane; no cooling doors and no propeller. In order to find the drag associated with the cooling doors and the propeller, Eqn. 53 through 58 and Figure 11 was required.

While this example does include the propeller, a portion of this does come from the cooling doors and no matter the portion there is still an increase in drag which means that internal combustion engines will likely never be as efficient as electric motors.

### 3.5 Converting Production Internal Combustion Airplanes to Electric

Not every airplane in production would make a very good electrically-powered airplane, therefore choosing the correct airframe becomes very important. For any given certified airplane in production there is a particular weight of batteries that the airplane can carry assuming the maximum gross weight cannot be violated. This value will be dependent upon the number of passengers desired and the size of the engine replaced by the electric motor. Using this value, the energy density of a battery to be used, and horsepower required to propel the particular airplane through the air, the duration of a flight, excluding takeoff, and the passenger-mpg can be determined.

The maximum gross weight and the empty weight, the number of passengers desired, the engine power available, and the L/D for a particular airspeed must be known about an airplane. These values are usually available in the Pilot Operating Handbook for most airplanes and are required for this analysis.

The first step in order to find the endurance of an airplane that is converted over to an electric airplane is to determine the size of the electric motor that is required. Assuming that the maximum gross weight cannot be violated then the power provided by the airplane's internal combustion engine can be used to find an electric motor of equivalent power. Then, if the maximum gross weight ( $W_i$ ), the empty weight of the airplane ( $W_{empty}$ ), the number of passengers ( $p$ ), the weight of the motor ( $W_{motor}$ ), the weight of the engine ( $W_{engine}$ ) and the weight of the fuel tanks ( $W_{fuel\ tanks}$ ) the total allowable weight of the batteries can be determined. As a note,  $W_{empty}$  includes the weight of the fuel tanks and the engine, also  $W_{engine}$  includes all of the various accessories such as hosing, oil, starter and various other components.

$$W_{batt} = W_i - W_{empty} - p(200) - W_{motor} + W_{engine} + W_{fuel\ tanks} \quad \text{Eqn. 59}$$

Taking this value of battery weight and then multiplying by the energy density of a battery, the total energy stored on board the airplane can be found. If the ThunderPower battery is used with an energy density of 0.1 (Hp-hr)/lb, then the total energy can be easily found<sup>68</sup>. Data regarding the ThunderPower batter can be found in Table 10.

The energy stored on board the airplane is not the only driving factor behind how far an airplane can fly. As mentioned before, aerodynamics plays a large role in the endurance and range of an airplane. Since the range is not known, Eqn. 47 could be used to solve for the average horsepower. This value could be plugged back into Eqn. 46 in order to find the distance. If the time aloft is desired then through simple algebra using the energy and the distance, the time could be determined.



$$HP_{ave} = E_T \frac{V_{ave}}{N} \quad \text{Eqn. 47}$$

Now that the maximum energy stored on board the airplane has been determined, if the power required is known for the airplane, then an approximate distance of flight can be determined. This value excludes climb out and descent and only looks at the cruising portion of the flight.

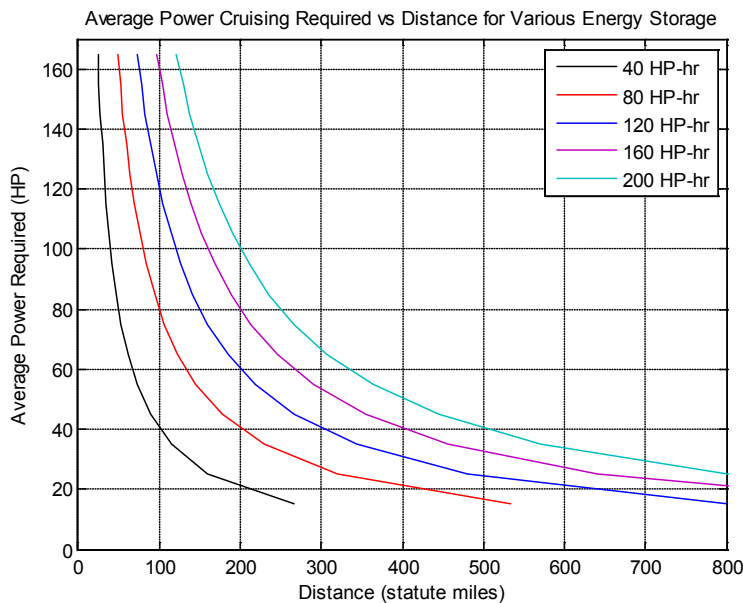

Figure 20: Average Power Cruising vs. Distance for Various Energy Requirements (at 86 knots)

Figure 20 shows that the average power required by the airplane. This figure is governed by Eqn. 47 for an average airspeed of 87 knots (100 mph). In this graph the less average power required by the airplane and the more energy stored on board then the farther the airplane can fly.

As a comparison, the Cessna 172 was analyzed in order to determine how many batteries it could carry with one passenger, how far it could fly and what its passenger-mpg would be.

Table 15: Cessna 172 Parameters<sup>16</sup>

Maximum Gross Weight ( $W_i$ )	2300 lbs
Empty Weight ( $W_{empty}$ )	1400
Number of Passengers ( $p$ )	1
Assumed Weight of Motor ( $W_{motor}$ )	100
Assumed Weight of Internal Combustion Engine ( $W_{engine}$ )	200
Maximum HP of Engine	160

Most of the parameters in Table 15 were found in the POH for the Cessna 172 except for the number of passengers, weight of the engine and the weight of the motor.  $W_{\text{engine}}$  and  $W_{\text{motore}}$  were assumptions and might vary slightly but for this analysis is a rough estimate and will be adequate. The weight of fuel tanks was not calculated and left at zero, in other words, they were not removed from the airplane.

Using Eqn. 59, the total weight of the batteries for the Cessna 172 becomes 800 pounds. Realistically, wiring, resistors, PCB's, mounts and various other components would lower this value of 800 pounds but for the analysis 800 pounds will be used.

Assuming that the ThunderPower TP7800 was used then the energy stored on board the airplane becomes 80 HP-hr<sup>68</sup>. Next, the POH states that in order to fly at 100 kts, 65% of the power is required. The maximum horsepower available is 160HP and assuming that an equivalently powerful electric motor replaced the internal combustion engine then the power required is 104 HP. Using this value and the energy stored on board the airplane, the total cruising distance can be determined from Eqn. 47. From this equation the Cessna 172 could only fly 76 nautical miles (88 statute miles) at an average speed of 100kts (115 mph).

If the Cessna were slowed down to 95 knots (110 mph) and a linear relationship between percent power required and airspeed was assumed, the Cessna 172 could fly 110 nautical miles (95 statute miles). This would mean that the percent power required was 50% which translates to 80 HP.

*Table 16: Energy Comparison of Airplanes<sup>(16, 60)</sup>*

	Pipistrel	EGenius	Cessna 172
Average Airspeed ( $V_{\text{ave}}$ )	113.7 mph	107.4 mph	110 mph
Energy Stored Onboard ( $E_T$ )	112 HP-hr	60.1 HP-hr	80 HP-hr
Power Required	46.9 HP	23.8 HP	80 HP
Distance (statute miles)	200	200	110
Number of Passengers (p)	4	2	1
Passenger-MPG	403.5	375.8	61.8

Table 16 compares the Pipistrel and EGenius airplanes from the GFC competition to the Cessna 172. In order to calculate the passenger-mpg, the energy conversion to gallons of gasoline was referenced ( $e_{87}$ ) which states that 33.7 kWh is equal to one gallon of 87 octane gasoline<sup>22</sup>. A fully electric Cessna 172 would achieve better passenger-mpg than the original internal combustion engine option which, according to the POH at 50% power, would achieve approximately 17passenger-mpg however it falls

very short of the EGenius and Pipisterl airplanes. Pipistrel is approximately 6.5 times better in passenger-mpg than the Cessna 172. This difference is primarily made up in the aerodynamics.

## Chapter 4 Conclusion

Electric airplanes are new in their designs and innovations and have primarily served as technology demonstrators. As battery energy density continues to get better, several companies have begun producing and certifying electrically powered motor-glanders because they do not require large amounts of stored energy. These high efficient airplanes take advantage of the atmospheric conditions in order to stay increase their endurance and range.

The Green Flight Challenge Competition, sponsored by NASA, was a recent competition that provided the staging and proving ground for fully electric airplanes. With the speed, distance, and efficiency requirements set forth by the competition, only fully electrically powered airplanes proved to be reasonable candidates in order to win.

If the range and endurance of these electric airplanes were computed using the classic range and endurance equations the results would say that they could not fly any distance for any duration because electric airplanes do not change weight over the course of the flight. Both the classic range and endurance equations are based upon the simple idea that internal combustion engine airplanes burn fuel as they fly. In the case of the electric airplane, battery weight does not diminish as they discharge current and voltage. Therefore, new range and endurance equations are required.

From these new range and endurance equations, which depend upon total energy stored on board the airplane and aerodynamic properties, an airspeed and altitude in order to maximize them can be determined. The airspeed for the best range results in the airspeed for the best glide, the airspeed at which minimum drag occurs. Then, the airspeed for the best endurance occurs for the case when the airplane experiences minimum drag. Both of these results for airspeed are the same for internal combustion engine airplanes. These equations depend upon the aerodynamic properties of the airplane and do not particularly care what the energy stored on board is. An important note is that as internal combustion airplanes burn fuel their weight changes which means that their best glide speed also changes. Decreased weight means that the speed for best aerodynamic efficiency (best glide speed or best L/D speed) would be slower. For an electric airplane that does not change weight, the best glide speed would remain constant throughout the flight profile. In terms of an electric airplane the velocity can be related to the energy discharge rate of the batteries.

The only other variable that can affect the range and endurance of an electric airplane during flight, besides the velocity, would be the altitude. Density is a function of altitude and varies with altitude

below roughly 36,000 feet as opposed to above 36,000 feet. Analyzing the results for below and above 36,000 feet, the optimal altitude to fly at which both optimizes the range and endurance would be to fly as high as possible. This analysis only takes into account cruising conditions and does not look at energy required to climb to altitude or the energy that can be recaptured on descent. Climbing to infinity is not only very difficult it is completely unreasonable if the flight leg is short. The higher the altitude the less the air density and the less the parasite drag on the airframe. With less density the propeller would speed and tip speeds would become a problem at the very high altitudes. Something not considered would be the optimum flight profile including the climb and descent portions.

Battery weight can be a significant portion of the airplanes weight as determined by a rough analysis of the GFC airplanes. Both of the GFC planes had high aerodynamic efficiency in order to achieve a high range and endurance for a lower power output and coupled with the high battery weight meant a lower power setting on course. The high battery weight required a high power motor to achieve altitude but at altitude with an efficient airplane, the power could be retarded and the energy consumed reduced thus increasing the endurance.

One of the main highlights of analyzing the GFC airplanes was determining that the propulsion, the battery system and electric motor, was not the only variable to meeting the competition requirements. On top of an efficient propulsion system, the teams used aerodynamically efficient airframes. These airframes helped reduce the amount of energy required by reducing the drag. Considerations like propellers, landing gear, high aspect ratio, laminar flow airfoils, and composite structures all lead to reduced drag and increased range and endurance.

The increased battery weight is not necessarily a negative affect besides when climbing to altitude. Once at cruising altitude the added weight helps to push the best glide speed to a higher airspeed. A higher best glide speed means that the airplane can travel faster while achieving the best range. Competition sailplane pilots will often add weight to their sailplanes in order to increase this best glide speed in order to fly faster and be aerodynamically efficient.

One way to increase endurance would be to recharge back up the batteries using solar film on the wings. For the GFC competition or one where the flight profile is short and any loss in efficiency could mean losing, the advantages and possibly disadvantages of solar film are present. The efficiency of solar film is still relatively low meaning that over a two hour flight, like the GFC competition, the energy regained would be low, especially compared to the potential losses incurred by placing the solar film on

the wings. Motor glider wings take advantage of laminar airflow in order to reduce the drag. If solar film was placed upon laminar airflow wings the boundary layer could detach early increasing the drag substantially. Now, the solar film that was added to collect free energy and increase the endurance has potentially decreased the endurance by more than it helped. Destroying the laminar flow on a glider could cut the endurance and range to much lower values.

If the two fully electric airplanes used in the GFC were converted over to internal combustion engine airplanes the aerodynamic efficiency of the airplanes could not be considered constant. Since internal combustion engines are far less efficient than electric motors, the heat lost due to this inefficiency must be dissipated. Sometimes heat in cold temperatures is not a bad item, however, in warmer climates heat can lead to damaged engine components and a possibly failure. Thus, cooling in the form of air intakes is required. These air intakes, or cooling ducts, automatically reduce the aerodynamic efficiency of the airplane. In some examples, where the drag on the airplane is low to begin with, cooling drag can drastically increase the drag of the airplane whereby increasing the energy required and decreasing the range and endurance. Internal combustion engines have two major penalties; they are far less efficient than electric motors, and they have an automatic increase in cooling drag because of this inefficiency.

Aerodynamic efficiency is the main reason that not every airplane can be converted over to an electric airplane, given the current level of battery technology, and make a 'good' electric airplane. Good, as in the performance is similar to the GFC electric airplanes. Many airplanes with internal combustion engines increase range or endurance by making the fuel tanks bigger instead of reducing the drag of the airplane. In terms of electric power, batteries are far heavier and take up more space than liquid fuel, meaning that it is much harder to keep adding batteries. By adding fuel the problem of efficiency is still present, the airplane still consumes the same amount of fuel as before and is just as inefficient.

Airframe design and aerodynamics are key in choosing a good electric airplane.

Electric airplanes will continue to evolve as battery technology and other forms of electric power generation such as hydrogen fuel cells continue to grow. While propulsion systems may change slightly with new batteries the aerodynamics must still be considered as a large factor contributing to the overall efficiency of the airplane. Range and endurance can be increased by flying at the appropriately derived speed; for range the best glide speed and for endurance the speed for minimum power. Increasing altitude also increases the range and endurance but the energy required to climb to altitude and the leg of the flight must be considered. If current production airplanes are to be converted to fully electric propulsion systems then airframes with low drag are ideal for increasing the range and

endurance. Motor-glider plan-forms are the best option for electric airplanes given the current level of battery technology and should be used in order to reduce energy consumption. The more aerodynamically efficient the airplane is, the less energy the airplane will require and the better the airplane will be for the environment. Future research in the area of optimum flight profile for an electric airplane, hybrid systems and battery technology are all areas that should be examined. New concepts, like the electric airplane, spur new ideas and new philosophies about what is conventional for an airplane. This thesis only looked at a few new ideas and standards but in order to examine the scope of the electric airplane, more research must be carried out.

## References

1. AC/DC telco Rectifier Delivers 96% Efficiency. eMedia Asia Ltd. 2008. 29 October 2011.
2. AE-1 Silent. Air Energy Entwicklungsgesellschaft. 2000. 30 September 2011.  
<[http://www.airenergy.de/html/ae-1\\_silent.html](http://www.airenergy.de/html/ae-1_silent.html)>
3. Aerovironment Electric UAV Sets Endurance Record. EV World. June 2007. 25 October 2011.  
<<http://evworld.com/news.cfm?newsid=15562>>
4. Airship Powered by an Electric Motor Developed by Albert and Gaston Tissandier Departing from Auteuil Paris. Library of Congress. 2011. 25 October 2011.  
<http://www.loc.gov/pictures/item/2002736254/>
5. AliSport: Silent Club, Electric Self-Launch Sailplane. AliSport, 2011. 25 October 2011.  
<[http://www.alisport.com/eu/eng/silent\\_b.htm](http://www.alisport.com/eu/eng/silent_b.htm)>
6. Anderson, John D. Aircraft Performance and Design. WCB/McGraw-Hill, 1999.
7. Asselin, Mario. An Introduction to Aircraft Performance. American Institute of Aeronautics and Astronautics, Inc. 1997.
8. Bachiochi. Motor Comparison. Circuit Cellar Magazine, Issue 216, pg. 78. July 2008
9. Barry, Kieth. Antares is First to Takeoff with Hydrogen. Wired. 9 July 2009. 25 October 2011.  
<<http://www.wired.com/autopia/2009/07/fuel-cell-flight/>>
10. Battery-Powered Plane: World's First Manned Flight on Dry Cell Batteries. Web Japane. 29 September 2006. 15 October 2011. <<http://web-japan.org/trends/science/sci060929.html>>
11. Battery Life (and Death). Electropedia. 2011. 29 October 2011.  
<<http://www.mpoweruk.com/life.htm>>
12. Battery Management System (BMS). Electropaedia. 2011. 25 October 2011.  
<<http://www.mpoweruk.com/bms.htm>>
13. Battery Solutions: Recycling. Battery Solutions. 2011. 29 October 2011.  
<<http://www.batteryrecycling.com/regulations>>
14. Battery Types and Battery Efficiency. BD Batteries. 2011. 29 October 2011.  
<<http://www.bdbatteries.com/peukert.php>>



15. Calb-400 Ah. ThunderStruck. 2011. 5 November 2011. <[http://www.thunderstruck-ev.com/index.php?dispatch=products.view&product\\_id=154](http://www.thunderstruck-ev.com/index.php?dispatch=products.view&product_id=154)>
16. Cessna 172 Pilot Operating Handbook. Cessna. 1978.
17. Cowley, Martin. Solar Challenger. Aeromodeller, June 1981. 25 October 2011. <[http://library.propdesigner.co.uk/solar\\_challenger.pdf](http://library.propdesigner.co.uk/solar_challenger.pdf)>
18. Curry, Marty. Solar-Power Research and Dryden. NASA: NASA Dryden Research Facility. December 2009. 11 October 2011. <<http://www.nasa.gov/centers/dryden/news/FactSheets/FS-054-DFRC.html>>
19. DA 20: Pilot's Operating Handbook. Diamond Aircraft. 2007.
20. E-Flight Electric Waix Achieves First Flight. Sonex. 2011. 25 October 2011. <[http://www.sonexaircraft.com/press/releases/pr\\_120310.html](http://www.sonexaircraft.com/press/releases/pr_120310.html)>
21. ElectraFlyerC Prototype. Electric Aircraft Association. 2011. 25 October 2011. <<http://www.electraflyer.com/electraflyerc.php>>
22. Electric Vehicles. US Department of Energy. 2 December 2011. 29 October 2011. <<http://www.fueleconomy.gov/feg/evtech.shtml>>
23. Flightstar e-Spyder. Experimental Aircraft Association. July 2009. 25 October 2011. <[http://www.eaa.org/news/2009/2009-07-19\\_espyder.asp](http://www.eaa.org/news/2009/2009-07-19_espyder.asp)>
24. Full Wave Bridge Rectifier. India Study Channel. 2011. 4 November 2011. <<http://www.indiastudychannel.com/projects/8-Full-Wave-Bridge-Rectifier.aspx>>
25. "Gaston Tissandier." *Encyclopædia Britannica: Encyclopædia Britannica Online*, 2011. 28 Oct. 2011. <<http://www.britannica.com/EBchecked/topic/596995/Gaston-Tissandier>>
26. GENS ACE 3300mah 6S1P 22.2V 25C Lipo Battery for Trex 500/550 and 1/8 Pro Buggy. HobbyPartz. 2011. 5 November 2011. <<http://www.hobbypartz.com/98p-25c-3300-6s1p.html>>
27. Grady, Mary. First Flight for Four-Engine Electric Airplane. AvWeb. September 2010. 15 October 2011. <[http://www.avweb.com/avwebflash/news/FirstFlightForFourEngineElectricAirplane\\_203258-1.html](http://www.avweb.com/avwebflash/news/FirstFlightForFourEngineElectricAirplane_203258-1.html)>

28. Grady, Mary. Italian Electric Airplane Reaches 155 mph. AvWeb. June 2009. 11 October 2011. <[http://www.avweb.com/avwebflash/news/ItalianElectricAirplaneReaches155mph\\_200577-1.html](http://www.avweb.com/avwebflash/news/ItalianElectricAirplaneReaches155mph_200577-1.html)>
29. Grade, Mary. Yuneec Electric LSA Hopeful Debuts at AirVenture. AvWeb. July 2009. 25 October 2011. <[http://www.avweb.com/news/airventure/EAAAirVenture2009\\_YuneecElectricLSAHopefulDebuts\\_200833-1.html](http://www.avweb.com/news/airventure/EAAAirVenture2009_YuneecElectricLSAHopefulDebuts_200833-1.html)>
30. Institut fur Flugzeugbau. Icare this Year was in Top Form. University of Stuttgart. November 2009. 11 October 2011. <<http://www.ifb.uni-stuttgart.de/en/forschung/flugzeugentwurf/icare>>
31. Jolly, Anpum. Eco-Tech: First Commercially Available Electric Aircraft Costs Less than Most Luxury Cars. Instamedia Network. 25 June 2009. 15 September 2011. <<http://www.ecofriend.com/entry/eco-tech-first-commercially-available-electric-aircraft-costs-less-than-most-luxury-cars/>>
32. Korzeniewski, Jeremy. Whats the Difference Between AC and DC? Which is Better for Electric Cars. 16<sup>th</sup> July 2009. 2 November 2011. <<http://www.green.autoblog.com/2009/07/16/greenlings-whats-the-difference-between-ac-and-dc-which-is-be/>>
33. Lange: Antares 20E Certified. Lange Flugzeugbau GmbH. 2 August 2006. 15 September 2011. <<http://www.glidermagazine.com/NewsArticle.asp?id=1539&y=2006>>
34. Lange Propulsion. Lange Flugzeugbau GmbH. 2011. 15 September 2011. <[http://www.lange-aviation.com/htm/english/products/antares\\_20e/propulsion.html](http://www.lange-aviation.com/htm/english/products/antares_20e/propulsion.html)>
35. Lange: Lange SWR.de The Research Aircraft Antares DLR H2 and Antares H3. Flugzeugbau GmbH. June 2011. 11 October 2011. <<http://www.lange-flugzeugbau.com/htm/english/news/news.html>>
36. Leoch 12V 100Ah Deep Cycle Gel Cell Battery. AtBatt. 2011. 5 November 2011. <<http://www.atbatt.com/product/23731.asp>>
37. Lowy, Joan. Hazard of Lithium Batteries on Planes Sparks Debate. MSNBC. 26 October 2010. 15 September 2011. <<http://www.msnbc.msn.com/id/39852461/ns/travel-news/t/hazard-lithium-batteries-planes-sparks-debate/#.TqrFJpsr2so>>
38. Maiden Flight of Silent 2 with Nose-Mounted Propulsion System. The Soaring Café. 22 March 2011. 25 October 2011. <<http://soaringcafe.com/2011/03/maiden-flight-of-silent-2-with-nose-mounted-propulsion-system/>>

39. MC30E Firefly with Electravia Propulsion System. Electravia. 2011. 25 October 2011.  
<<http://www.electravia.fr/mc30eEng.php>>
40. McCormick, Barnes. Aerodynamics Aeronautics and Flight Mechanics. John Wiley & Sons, Inc. 1995.
41. Moore, Bill. Sunseeker Seeks New Records. EV World. June 2004. 11 October 2011.  
<<http://www.evworld.com/article.cfm?storyid=709>>
42. NASA Dryden Fact Sheet: Pathfinder Solar Powered Aircraft. NASA: NASA Dryden Flight Research Center. March 2008. 25 October 2011.  
<<http://www.nasa.gov/centers/dryden/news/FactSheets/FS-034-DFRC.html>>
43. Naughton, Russell. Remote Piloted Aerial Vehicles. Monash University. 2003. 25 October 2011.  
<[http://www.ctie.monash.edu/hargrave/rpav\\_home.html#Beginnings](http://www.ctie.monash.edu/hargrave/rpav_home.html#Beginnings)>
44. NEMA Premium. NEMA. 2006. 29 October 2011. <<http://www.nema.org/stds/complimentary-docs/upload/MG1premium.pdf>>
45. Newcome, Laurence R. Unmanned Aviation: A Brief History of Unmanned Aerial Vehicles. AIAA, 2004
46. NiCD Replacement for Makita 1210(632277-5) Battery - Fits 6011D. AtBatt. 2011. 5 November 2011. <<http://www.atbatt.com/product/6639.asp>>
47. Niles, Russ. Boeing Flies Fuel Cell Aircraft. AvWeb. April 2008. 15 October 2011.  
<[http://www.avweb.com/avwebflash/news/BoeingFliesFuelCellAircraft\\_197531-1.html](http://www.avweb.com/avwebflash/news/BoeingFliesFuelCellAircraft_197531-1.html)>
48. Noth, Andre. History of Solar Flight. Autonomous Systems Lab, Swiss Federal Institute of Technology Zürich. 2008 July. 25 October 2011.  
<[http://www.asl.ethz.ch/research/asl/skysailor/History\\_of\\_Solar\\_Flight.pdf](http://www.asl.ethz.ch/research/asl/skysailor/History_of_Solar_Flight.pdf)>
49. Oswald, Bailey. <http://naca.central.cranfield.ac.uk/reports/1933/naca-report-408.pdf>
50. Pathfinder Aircraft in Flight. NASA: Dryden Research Center. February 2002. 25 October 2011.  
<<http://www.dfrc.nasa.gov/gallery/photo/Pathfinder/HTML/EC95-43207-76.html>>
51. Paur, Jason. Solar Impulse Completes First Flight. Wired. 2011. 25 October 2011.  
<<http://www.wired.com/autopia/2009/12/solar-impulse-completes-first-flight/>>
52. PC-Aero: Official FIRST FLIGHT successful. PC-Aero. March 2011. 25 October 2011.  
<<http://www.pc-aero.de/>>

53. Pew, Glenn. APAME Announces Electric Flight. AvWeb. 29 December 2007. 11 October 2011. <[http://www.avweb.com/avwebflash/news/APAMEAnnouncesElectricFlight\\_196847-1.html](http://www.avweb.com/avwebflash/news/APAMEAnnouncesElectricFlight_196847-1.html)>
54. Pew, Glenn. Electric Aircraft Outbreak, Speed or Distance. AvWeb. July 2011. 25 October 2011. <[http://www.avweb.com/avwebflash/news/electric\\_aircraft\\_speed\\_distance\\_cafe\\_flight\\_challenge\\_204937-1.html](http://www.avweb.com/avwebflash/news/electric_aircraft_speed_distance_cafe_flight_challenge_204937-1.html)>
55. Phoenix S-LSA Glider 04/U15; Aircraft Operating Instructions. <[http://www.phoenixairusa.com/uploads/AOI\\_Phoenix\\_04-U15.pdf](http://www.phoenixairusa.com/uploads/AOI_Phoenix_04-U15.pdf)>
56. Reichmann, Helmut. Cross Country Soaring. Thomson Publications, 1978.
57. Richard, Michael Graham. Zephyr Solar Plane Lands After Over 2 Weeks in the Air, Setting New World Record. TreeHugger. July 2010. 25 October 2011. <<http://www.treehugger.com/aviation/zephyr-solar-plane-lands-after-over-2-weeks-in-the-air-setting-new-world-record.html>>
58. Seredynski, Paul. Decoding Electric Car MPG. 10 December 2010. 29 October 2011. <<http://www.edmunds.com/fuel-economy/decoding-electric-car-mpg.html>>
59. Shorai LFX14L2-BS12 Lithium-Iron Phosphate (LiFePO4) Powersports Battery. AtBatt. 2011. 5 November 2011. <<http://www.atbatt.com/product/24414.asp>>
60. Sigler, Dean. Green Flight Challenge Final Results. CAFE Foundation. 13 October 2011. 15 September 2011. <<http://blog.cafefoundation.org/?p=4679>>
61. Sigler, Dean. "Dale Kramer and his Electric Lazair." Kitplanes, Volume 28, Number 12. December 2011, pages 31-35. Belvoir Publications. ISSN 0891-1851
62. SkySpark: The History of a Challenge. DigiSky SRI. 2009. 15 October 2011. <<http://www.skyspark.eu/web/eng/storia.php>>
63. Solar Aviation History. Solar Impulse. 2011. 30 September 2011. <[http://solarimpulse.com/common/documents/challenge\\_history.php?lang=en&group=challenge](http://solarimpulse.com/common/documents/challenge_history.php?lang=en&group=challenge)>
64. Stemme S10: Pilot Operating Handbook. Stemme Gbh. 1989.
65. Taurus Electro. Pipistrel. 2011. 25 September 2011. <<http://www.pipistrel.si/plane/taurus-electro/overview>>

66. Technical Standard Orders (TSO). FAA. 2011. 29 October 2011.  
<[http://www.faa.gov/aircraft/air\\_cert/design\\_approvals/tso/](http://www.faa.gov/aircraft/air_cert/design_approvals/tso/)>
67. Tesla: Increasing Energy Density Means Increasing Range. Tesla. 2011. 15 September 2011.  
<<http://www.teslamotors.com/roadster/technology/battery>>
68. Thunder Power RC G6 Pro Lite 25C 7800mAh 6-Cell/6S 22.2V Lipo Battery. DragonFly Innovations INC. 2011. 15 September 2011.  
<<http://www.rctoys.com/rc-toys-and-parts/TP7800-6SPL25/RC-PARTS-THUNDER-POWER-RC-25C-G6-LIPO-BATT.html>>
69. TSO-C179: Rechargeable Lithium Cells and Lithium Batteries. FAA. 22 August 2006. 25 October 2011.  
<[http://rgl.faa.gov/Regulatory\\_and\\_Guidance\\_Library/rgtso.nsf/0/afece612ce71d5e6862571d8005aaeb0/\\$FILE/TSO-C179.pdf](http://rgl.faa.gov/Regulatory_and_Guidance_Library/rgtso.nsf/0/afece612ce71d5e6862571d8005aaeb0/$FILE/TSO-C179.pdf)>
70. UFM/MAURO SOLAR RISER. Experimental Aircraft Association, Inc. 2008. 11 October 2011.  
<<http://www.airventuremuseum.org/collection/aircraft/UFM-Mauro%20Solar%20Riser.asp>>
71. Van Laer, Raphael. Peak Uncertainty, When Will We Run Out Of Fossil Fuels? Ion Publications LLC. 2010. 15 September 2011.  
<[http://www.science20.com/absentminded\\_professor/peak\\_uncertainty\\_when\\_will\\_we\\_run\\_out\\_fossil\\_fuels-70294](http://www.science20.com/absentminded_professor/peak_uncertainty_when_will_we_run_out_fossil_fuels-70294)>
72. ElectraFlyer Trike. Electric Aircraft Group. 2011. 25 October 2011.  
<<http://www.electraflyer.com/trike.php>>
73. Wilson, Tracy V. What Causes Laptop Batteries to Overheat? How Stuff Works. 2011. September 15, 2011. <<http://computer.howstuffworks.com/dell-battery-fire.htm>>
74. World's first serial hybrid electric aircraft to fly at Le Bourget. Siemens. 20 June 2011. 15 September 2011.  
<[http://www.siemens.com/press/en/pressrelease/?press=/en/pressrelease/2011/corporate\\_communication/axx20110666.htm](http://www.siemens.com/press/en/pressrelease/?press=/en/pressrelease/2011/corporate_communication/axx20110666.htm)>
75. Yechout, T. Hallgren, W. Introduction to Aircraft Flight Mechanics: Performance, Static Stability, and Classical Feedback Control. AIAA. 2011. 15 September 2011.  
<<http://ebooks.aiaa.org/BookStore/pagedisplay.do?genre=book&pub=aiaa&id=9781600860782&page=S-FC>>
76. Yuneec e430 Electric Aircraft. Yuneec International. 2011. 15 September 2011.  
<[http://yuneecouk.site.securepod.com/Aircraft\\_specification.html](http://yuneecouk.site.securepod.com/Aircraft_specification.html)>

77. Zephyr UAV. QinetiQ. 2011. 25 October 2011.

<[http://www2.qinetiq.com/home\\_farnborough\\_airshow/unmanned\\_air\\_systems/zephyr.html](http://www2.qinetiq.com/home_farnborough_airshow/unmanned_air_systems/zephyr.html)>