

5-2015

## Design and Manufacturing of a Mecanum Wheel for the Magnetic Climbing Robot

Shruti Deepak Kamdar

Follow this and additional works at: <https://commons.erau.edu/edt>



Part of the [Mechanical Engineering Commons](#)

---

### Scholarly Commons Citation

Kamdar, Shruti Deepak, "Design and Manufacturing of a Mecanum Wheel for the Magnetic Climbing Robot" (2015). *Dissertations and Theses*. 269.

<https://commons.erau.edu/edt/269>

This Thesis - Open Access is brought to you for free and open access by Scholarly Commons. It has been accepted for inclusion in Dissertations and Theses by an authorized administrator of Scholarly Commons. For more information, please contact [commons@erau.edu](mailto:commons@erau.edu).

DESIGN AND MANUFACTURING OF A MECANUM WHEEL FOR THE  
MAGNETIC CLIMBING ROBOT

by

**Shruti Deepak Kamdar**

(Master of Science in Mechanical Engineering, M.S.M.E)

A Thesis Submitted To the College Of Engineering, Department Of Mechanical  
Engineering in Partial Fulfillment of the Requirements for the Degree of  
Master of Science in Mechanical Engineering

Embry-Riddle Aeronautical University  
Daytona Beach, Florida  
May 2015

DESIGN AND MANUFACTURING OF A MECANUM WHEEL FOR THE  
MAGNETIC CLIMBING ROBOT

by

**Shruti Deepak Kamdar**

(Master of Science in Mechanical Engineering, M.S.M.E)

This thesis was prepared under the guidance of candidate's Thesis Committee Chair, Dr.Sathya Gangadharan Ph.D., P.E., C.Mfg.E. Professor, Daytona Beach Campus, and Dr. Birce Dikici, Assistant Professor, Daytona Beach Campus, and Dr. Ilteris Demirkiran, Professor, Daytona Beach Campus, and has been approved by the Thesis Committee. It was submitted to the Department of Mechanical Engineering in partial fulfillment of the requirements for the degree of Master of Science in Mechanical Engineering

Thesis Review Committee:

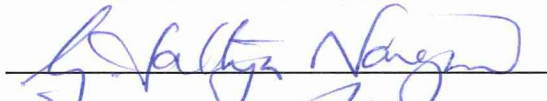
  
Sathya Gangadharan Ph.D., P.E., C.Mfg.E.  
Committee Chair

  
Birce Dikici, Ph.D.  
Committee Member

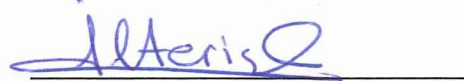
  
Ilteris Demirkiran, Ph.D.  
Committee Member

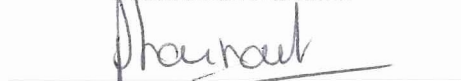
  
Jean-Michel Dhainaut, Ph.D.  
Graduate Program Chair,  
Mechanical Engineering

  
Charles F. Reinholtz, Ph.D.  
Department Chair,  
Mechanical Engineering

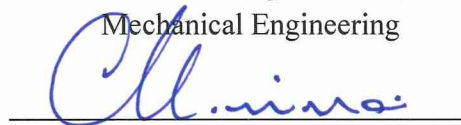
  
Maj Mirmirani, Ph.D.  
Dean, College of Engineering

  
Robert Oxley, Ph.D.  
Associate Vice-President of Academics

4-22-15  
Date

**This thesis is dedicated to my parents and my brother for their endless love, support and encouragement and also to all those who believe in the richness of learning.**



# ACKNOWLEDGEMENT

---

Firstly, I would like to thank God for giving me all the strength to complete this thesis. From the bottom of my heart, I would like to thank my parents for their unconditional love and endless support. I would like to thank them for always having faith in me and encouraging me to set higher targets. If it wasn't for you both I possibly might not had been able to do this thesis.

I would like to express the deepest appreciation to my committee members for their constant support and motivation. I would like to convey my thanks to Dr. Sathya Gangadharan for his guidance, mentoring and tutoring which helped me completing this thesis successfully. I am also grateful to Dr. Birce Dikici and Dr. Ilteris Demirkiran for their constant support and guidance throughout the thesis. I would also like to thank Dr. Heidi Steinhauer for her technical help during the study.

I would also like to convey my deepest thanks to Keith Schlee, Vice President of Helical Robotics for introducing this study to me and for all the guidance needed despite of his busy schedule. I am very grateful to him for allowing me to visit his manufacturing firm in Wisconsin to see the robot in working condition. I owe you my deepest gratitude for always helping me going out of your way to help me with this thesis.

I would like to express my gratitude to my good friend Nii Manor Nartey without whose support I would not had been able to reach this height. You stood like a backbone for this thesis and cannot thank you enough for your help and time. Your encouragement and constant support helped me a lot to complete this thesis. I would also like to thank my brother Trupal Kamdar for his love and support. I would also like to thank my friend Gazal Nagi for being my inspiration and encouraging me throughout my Masters. I would also like to thank my other friends who have always been grateful and helpful throughout my Master's Program. Thank you all for always being there on my side without any expectations. I am the one lucky person to have such wonderful people as a part of my life.

# ABSTRACT

---

Researcher: Shruti Deepak Kamdar

Title: Design and Manufacturing of a Mecanum Wheel for the Magnetic Climbing Robot

Institution: Embry-Riddle Aeronautical University

Degree: Master of Science in Mechanical Engineering, M.S.M.E

Year: 2015

An AndyMark Mecanum Wheel has been re-designed for better performance and utilization by Helical Robotics. Mecanum Wheel is a complex "Omni-Directional" wheel that currently contains several drawbacks. The drawbacks include complex design, usage of hobby grade material, bumps in rollers, etc. A comprehensive design of the Mecanum wheel is being presented using Computer Aided Software, CAD and analysis tools, such as Finite Element Analysis, FEA. The different concepts were hand sketched using various parameters and then implemented in a CAD software - CATIA. The Mecanum Wheel's feasibility was thoroughly studied through ANSYS software. Load analysis was performed using various materials and several manufacturing processes carefully, to check the achievability of the wheel. In conclusion, the Mecanum wheel was successfully re-designed and manufactured to meet the requirements and specifications of Helical Robotics.

# TABLE OF CONTENTS

---

Thesis Review Committee.....	ii
Acknowledgement .....	iv
Abstract .....	v
List of Figures .....	x
Nomenclature .....	xv
Introduction .....	xvi

## CHAPTER 1

### PROJECT INTRODUCTION

1.1 Overview .....	1
1.2 Current Wheel Types and Specifications .....	2
1.3 Company Overview.....	5
1.4 Problem Statements and Objectives.....	5

## CHAPTER 2

### FUNDAMENTALS OF MACHINE DESIGN WITHIN MECHANICAL AND MANUFACTURING ENGINEERING

2.1 Background .....	7
2.2 The Design Process .....	9
2.3 Factors to be Considered in Machine Design.....	11

2.4	Manufacturing .....	12
2.5	Manufacturing System .....	13
2.6	Finite Element Analysis (FEA) .....	15
2.7	Factor of Safety (F.O.S) .....	17
2.8	Computer Aided Design.....	18
2.9	Structural Design Optimization.....	19

### **CHAPTER 3**

#### **MECANUM WHEEL DESIGN DEVELOPMENT**

3.1	Proposed (New) Design Solution.....	20
3.2	Plate Concept 1.....	21
3.3	Plate Concept 2.....	22
3.4	Plate Concept 3.....	24
3.5	Plate Concept 4.....	25
3.6	Plate Concepts 5 and 6 .....	26
3.7	Wheel Design 1 .....	27
3.8	Wheel Design 2 .....	28
3.9	Wheel Design in GSD .....	29
3.10	Modified Wheel Design in GSD .....	35



## **CHAPTER 4**

### **FINITE ELEMENT ANALYSIS OF MECANUM WHEEL**

4.1	Finite Element Analysis .....	42
4.2	FEA Analysis of Mecanum Wheel Designed in GSD .....	43
4.3	Finite Element Analysis Using Structural Steel.....	48
4.4	Finite Design Analysis for Modified Design Using Structural Steel.....	51
4.5	Finite Design Analysis for Modified Design Using Aluminum Alloy .....	53

## **CHAPTER 5**

### **MANUFACTURING PROCESS AND MATERIAL PROPOSED FOR MECANUM WHEEL**

5.1	Manufacturing of Rollers .....	56
5.2	Application of Rubber on the Core .....	57
5.3	Material Used for Manufacturing Roller.....	59
5.4	Rubber Rollers.....	63
5.5	Core Manufacturing Material and Manufacturing Process .....	64
5.6	Roller Bearing .....	66
5.7	Manufacturing of Wheel Structure.....	66
5.8	Traction in Mecanum Wheel.....	71
5.9	Roller Bumpiness .....	75
5.10	Calculation of Kinematic Velocity and Force for Both Omni-directional and Mecanum Wheel.....	80

## **CHAPTER 6**

### **CONCLUSION AND FURTHER RESEARCH**

5.1	Results Accomplished.....	84
5.2	Further Studies / Research.....	87

### **REFERENCES**

# LIST OF FIGURES

---

## CHAPTER 1

**Figure 1.1:** Mecanum Wheels Mounted on Robot Manufactured by Helical Robotics ....2

**Figure 1.2:** Mecanum Wheel Configuration for Omni-directional Vehicle.....4

## CHAPTER 2

**Figure 2.1:** General Procedure in Machine Design.....7

**Figure 2.2:** Continuous Design Iterative Process.....10

**Figure 2.3:** Manufacturing as an Input-Output System.....14

**Figure 2.4:** FEA Simulation of the Damage of San Francisco Oakland Bay Bridge  
Caused by the 1989 Loma Prieta Earthquake.....16

**Figure 2.5:** FEA Simulation of Crush of a Car in Roll-Over Situation.....17

## CHAPTER 3

**Figure 3.1:** Plate Concept 1 Designed in CATIA & AndyMark Wheel  
Design.....21

**Figure 3.2:** Plate Concept 2 Designed in CATIA and Mecanum Wheel by  
AndyMark.....22

<b>Figure 3.3:</b> Plate Concept 3 with Teeth at an Angle Designed in CATIA.....	24
<b>Figure 3.4:</b> Plate Concept 4 Designed in CATIA.....	25
<b>Figure 3.5:</b> Plate Concept 5 and Plate Concept 6 Designed in CATIA.....	26
<b>Figure 3.6:</b> Mecanum Wheel Design 1 Designed in CATIA Using GSD Workbench.....	27
<b>Figure 3.7:</b> Mecanum Wheel Design 2 Designed using GSD and Part Design Workbench.....	28
<b>Figure 3.8:</b> Roller Profile Designed in CATIA.....	30
<b>Figure 3.9:</b> Circular Pattern of Rollers Created in CATIA.....	31
<b>Figure 3.10:</b> Design of the Flange Along with its Dimensions in CATIA.....	32
<b>Figure 3.11:</b> Design and Dimension of Pad and the Dimension of the Quadrant.....	33
<b>Figure 3.12:</b> 4-View of Mecanum Wheel Designed in GSD Workbench.....	34
<b>Figure 3.13:</b> Plane Created at an Offset from the Tip of Roller.....	36
<b>Figure 3.14:</b> Creation of Second Plane Choosing the First Plane as Reference.....	36
<b>Figure 3.15:</b> Geometry Showing the Creation of all the Three Planes.....	37
<b>Figure 3.16:</b> Creation of Flange by Joining the Three Planes Created in Geometry.....	38

<b>Figure 3.17:</b> Extrusion of the Rectangle by Creating the Profile.....	38
<b>Figure 3.18:</b> Creation of the Pattern Using the Special Feature Circular Pattern in CATIA.....	39
<b>Figure 3.19:</b> Creation of Hole to Fit in Bolts and then Creating Circular Pattern of Hole.....	39
<b>Figure 3.20:</b> Creation of Hole to Fill the Center of the Wheel.....	40
<b>Figure 3.21:</b> Creation of the Pocket to make Space for the Hub.....	40
<b>Figure 3.22:</b> Modified Mecanum Wheel 1 Designed in CATIA.....	41

## CHAPTER 4

<b>Figure 4.1:</b> Properties of Aluminum Alloy Derived from ANSYS.....	43
<b>Figure 4.2:</b> Manual Contact of Roller Created with Plane in ANSYS.....	44
<b>Figure 4.3:</b> Mesh Generated by ANSYS for Aluminum Wheel.....	44
<b>Figure 4.4:</b> Details of Meshing for Aluminum Wheel.....	45
<b>Figure 4.5:</b> Application of Forces at the Center of the Mecanum Wheel.....	46
<b>Figure 4.6:</b> Force Parameters Used for the Mecanum Wheel.....	46
<b>Figure 4.7:</b> Deformation Noticed in Aluminum Wheel.....	47
<b>Figure 4.8:</b> Equivalent Stress Distribution Noticed in Mecanum Wheel.....	47
<b>Figure 4.9:</b> Factor of Safety Calculated for Mecanum Wheel.....	48

<b>Figure 4.10:</b> Parameter for Structural Steel and Aluminum Material.....	49
<b>Figure 4.11:</b> Deformation Seen in the Mecanum Wheel while Using Structural Steel...	50
<b>Figure 4.12:</b> Equivalent Stress Distribution in Steel Wheel.....	50
<b>Figure 4.13:</b> Mesh Generated for Mecanum Wheel.....	51
<b>Figure 4.14:</b> Deformation Undergone by Structure Using Structural Steel.....	52
<b>Figure 4.15:</b> Equivalent Stress Distribution Noticed in Structural Steel Wheel.....	52
<b>Figure 4.16:</b> Safety Factor Noticed in Mecanum Wheel Using Structural Steel.....	53
<b>Figure 4.17:</b> Total Deformation Seen when Using Aluminum Alloy.....	54
<b>Figure 4.18:</b> Von-Misses Stress Noticed for Aluminum Wheel.....	54
<b>Figure 4.19:</b> Safety Factor Noticed in Aluminum Wheel.....	55

## **CHAPTER 5**

<b>Figure 5.1:</b> Shore Hardness Scale.....	59
<b>Figure 5.2:</b> Durometer Comparisons of Materials.....	60
<b>Figure 5.3:</b> Comparison between Different Materials Depending on their Temperature.....	62
<b>Figure 5.4:</b> Gray Rubber Roller.....	64
<b>Figure 5.5:</b> Bottom View of Mecanum Wheel Roller.....	72
<b>Figure 5.6:</b> Change in Vector Components due to Forward Motion.....	73

**Figure 5.7:** Increase Noticed in Motor Torque.....74  
**Figure 5.8:** Roller Profile.....76

**CHAPTER 6**

**Figure 6.1:** Final Design of the Mecanum Wheel .....87

# NOMENCLATURE

---

CAD = Computer-Aided Design

CAM = Computer- Aided Manufacturing

CAE = Computer-Aided Engineering

CATIA= Computer-Aided Three-Dimensional Interactive Application

CNC = Computerized Numerical Control

FEA = Finite Element Analysis

$F_s$  = factor of safety

$F_f$  = Forward Force

$F_r$  = Strafe Force

$F_r$  = Strafe Force

$F_c$ = Reaction force produced by the floor on the bottom of the Mecanum Wheel roller

GSD = Generative Sheet Design

Psi = Pounds per Square Inch

R= roller maximum radius

S= distance which is measured along the roller axis

$V_F$  = Forward Velocity

$V_r$  = Strafe velocity

$V_D$  = Diagonal velocity

$\Theta$ = angle

$\omega$  = wheel speed

$\tau$  = Torque



# INTRODUCTION

---

Chapter 1 introduces the current wheel design and specifications used by AndyMark. It also includes manufacturing process and materials used by AndyMark. It also highlights the requirement to carry this project and states the problems and objectives. Chapter 2 details the background information on manufacturing and fundamentals of machine design. Chapter 3 describes the proposed design and various solutions, keeping in mind the fundamentals mentioned in Chapter 2. Chapter 4 consists of finite element analysis performed on the design to show its feasibility. Chapter 5 compares the different manufacturing materials and processes chosen for the current design. Chapter 6 presents the comparison between the early design phase and final design of the element. It also mentions the results achieved while highlighting the need for further research and studies.

# CHAPTER 1

---

## PROJECT INTRODUCTION

### *1.1 Overview*

The purpose of this thesis is to re-design the Mecanum Wheel produced by a company called AndyMark. Mecanum Wheels produced by AndyMark are currently being used by the company Helical Robotics for its Robots. Different wheel plates have been designed keeping the requirements and specifications in mind. These wheel plates were re-designed by AndyMark to avoid any legal complications from the patented wheel plates already being designed and used by a competitor. To make the re-designed wheel stand out from the current one, some of the dimensions of the wheel were significantly improved upon. The combinations of several different manufacturing processes along with different materials helped in concluding the best design which will be later covered thoroughly in this thesis. Load analysis was performed on the wheel to check feasibility. A significant amount of research was concluded and taken into account regarding wheel efficiency.

Omni-directional wheels have been used in robotics, in different industries and in logistics for many years. The first Omni-directional wheel was patented in 1919 by J. Grabowiecki in US, which was not famous. Mecanum Wheels were first invented in 1973 by Swedish inventor Bengt Ilon [1]. This wheel is designed in such a way that, the rollers are mounted around the circumference of the wheel at 45 degrees to the wheel plane. This design of wheel allows for in- place rotation which prevents ground friction to a great extent and results into low driving torque. Mecanum Wheels allow a robot to achieve

Omni-directional movement while supporting large weights. A Mecanum-style wheel drive consists of two main components which are visible in Figure 1.1 below [2]:



*Figure 1.1: Mecanum Wheels Mounted on Robot Manufactured by Helical Robotics [2]*

Mecanum-style drive uses 4 wheels from which, 2 are “left” wheels and 2 are “right” wheels. One right and left wheel is on each side of the robot. Each wheel is driven independently which requires 4 individual motors [3]. The Figure 1.1 shows the magnetic climbing robot manufactured by Helical Robotics. This robot is lightweight and portable and the magnet used by the robot also does not touch the work surface. It can climb up to 7 ft. height without using any wireless components. This thesis study only concentrates on the designing of the Mecanum Wheel and analyzing its manufacturing process and material.

## *1.2 Current Wheel Types and Specifications*

Currently AndyMark manufactures multiple different sizes of wheels- 4” wheels, 6” wheels, 8” wheel and 10” wheel are the different sizes of wheels manufactured by AndyMark. The number of rollers to be mounted on the circumference of the wheel

depends on the size of the wheel. The 4" Mecanum Wheel utilizes 12 rollers which are positioned between 2 50/50 ABS and PC plastic hub valves. The 6" Mecanum HD wheel utilizes 15 rollers positioned between 2 plates. The 8" Mecanum Wheel utilizes 12 rollers, positioned between two 2 Aluminum side plates. The 10" Mecanum Wheels utilize 12 rollers positioned between 2 plates. The Steel version has a tubular hub on the interior [3].

Common specifications among 6", 8", and 10" Mecanum Wheels are as follows:

- All the wheels accept 1.125" OD ball bearings.
- Co-efficient of friction is tested on tight pile carpet.
- All wheels are designed to fit AndyMark hubs.
- All the rollers used by wheels uses SBR rubber.
- The width of 1.64" is kept at the hub.
- 6 holes are drilled around a 1.875" diameter circle.
- All 6" and 8" wheel rollers are made of a polycarbonate interior and a urethane exterior.

Rubber rollers are crammed in between 2 Steel plates and which are 15 in number. Steel plates are then riveted and bolted to two interior cone-shaped Aluminum pieces, which forms the interior hub of the wheel. These two interior pieces are crammed together at the bore with a thickness of 0.25 inch. These wheels are driven in two ways: with a sprocket or pulley in a "dead axle" setup or with a hub in a "live axle" setup.

Dead axle is where a sprocket or a pulley is attached directly to the wheel and the assembly spins on a stationary shaft. Live axle wheel is where the wheel is attached to a hub and rotates with the shaft [3].

Ilon's Mecanum Wheel is designed in such a way that the rollers placed at an angle translate a portion of the force in the rotational direction to a force normal to the wheel direction. The resulting total force from each individual wheel produces a total force vector in any desired direction thus allowing the platform to move freely in the direction of the resulting force vector without changing the direction of the wheels themselves [1].

For a Mecanum Wheel to achieve Omni-directional movement, the wheels are arranged on the platform in a configuration as shown in Figure 1.2 below [4]:

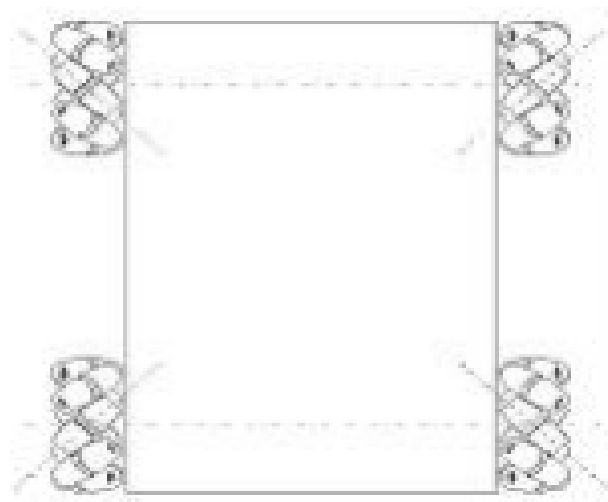

*Figure 1.2: Mecanum Wheel Configuration for Omni-directional Vehicle [4]*

Mecanum Wheel has a disadvantage resulting in reducing its efficiency. Large amount of forces are lost in one direction through the translation into a resulting force by the diagonally, only front and rear opposing wheels are spinning while the rollers on the other two wheels cause direct drag against which motors have to fight [1].

### *1.3 Company Overview*

The reference Mecanum Wheel is manufactured by AndyMark Company which is currently based in US and which is a supplier for robot parts, robot kits, robot wheels, Omni wheels, Mecanum Wheels and many more different wheels [3]. This Thesis is carried out with the guidance of the company Helical Robotics which is currently using Mecanum Wheels manufactured by AndyMark. Helical Robotics is the company based in Oregon, Wisconsin founded in 2010. They are known for their custom-built robots based on the customer's needs. They have recently started manufacturing magnetic wheeled robots which climbs pipes [5].

### *1.4 Problem Statements and Objectives*

One of the main problems faced by Helical Robotics in using Mecanum Wheel manufactured by AndyMark is that the wheel is not of expected quality and is unable to withstand high loads. The rollers have been reportedly performing poor. The material on the rollers has been reported to be ripping away after some usage. They are also sensitive to high temperature environments, causing them to fail, unable to withstand intense heat.

The standard AndyMark Mecanum Wheel is made out of Steel which has high strength/weight ratio and relatively good fatigue strength, however, not cost effective. Some of the common typical problems with the Mecanum Wheel are:

- Unable to perform smooth motion.
- Roller traction is seen in wet or dusty hard surfaces.
- When subjected to high lateral loads, the roller wears away and is damaged.
- Roller supports under high load applications.
- The current weight of the wheel is a serious concern.
- Expensive tooling is required to manufacture the wheel due to the complex design, tight tolerances, engineering development etc.
- The complex design of the wheel has too many individual components.
- Roller supports, bolts, nuts, etc. which are closed to hard rolling surface such that very small bumps and ledges when vehicle translates sideways.
- Roller bearings do not perform well and clog in high traffic or dusty/dirty environments.
- Rollers are damaged in high temperature environments.
- Wheels can also oxidize in maritime environments.

# CHAPTER 2

---

## FUNDAMENTALS OF MACHINE DESIGN WITHIN MECHANICAL AND MANUFACTURING ENGINEERING

### 2.1 *Background*

A new or a better machine is one which is more economical in terms of cost and operation. While designing a machine or any of its components, there are no rigid rules to be followed. However, below are some general procedures to solve a design problem and is also shown in Figure 2.1 [6].

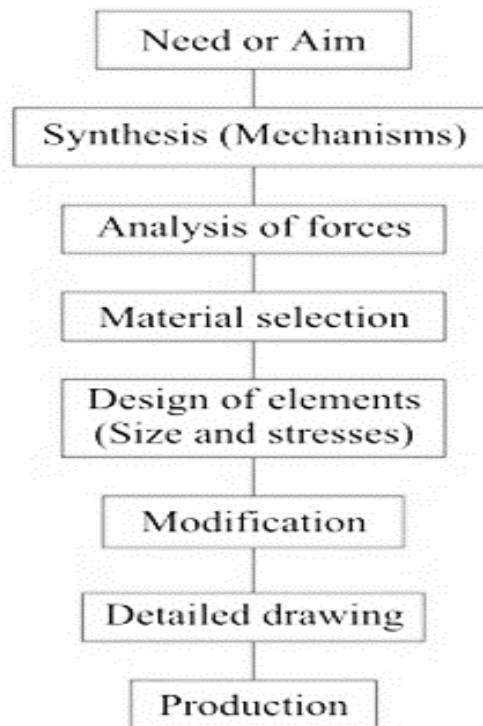

*Figure 2.1: General Procedure in Machine Design [6]*



- 1. Recognition of need:** The first step is to make a complete statement which should indicate a need, aim or purpose for which the machine is to be design.
- 2. Synthesis (Mechanisms):** Select the mechanism which will give the desired motion.
- 3. Analysis of forces:** Find the forces acting on each member of the machine and the energy that is transmitted by each member.
- 4. Material Selection:** Select the suitable material for each member.
- 5. The Design of Element (Size and stresses):** Find the size of each member of the machine by calculating the force acting on the member and the permissible stresses for the material. Also, it should be kept in mind that each member should not deflect or deform than the permissible limit.
- 6. Modification:** Modify the size of the member to facilitate manufacture. Modification is also essential to reduce overall cost of manufacturing.
- 7. Detailed Drawing:** Draw the detailed drawing of each component of the machine with all the required specifications necessary for manufacturing.
- 8. Production:** The component is manufactured as per the detailed drawing in the workshop.

Design is the process where proper decision has to be taken. To design is to articulate a plan to satisfy a particular need and to create something with physical application. The designer must evaluate precisely for which criteria to use to characterize designs and their expected performance. Design should process on the real facts and just not from the information available. Analysis should be done on that design to check its

reliability and should not be judged on perception. The design should therefore be analyzed to check its compatibility. In this thesis, the analysis has been performed to produce valuable proof. Decision making is a very crucial step that has to be taken at every step. For example, making of two cars may be different, but both may be reasonable cars and will serve the same purpose but their designs will be different. The designers take into consideration different factors and come up with ideas to design different components which lead to an optimum design.

## *2.2 The Design Process*

There are different ways in which problem related to design can be solved. The five steps involved in solving a design problem are [7]:

1. Defining the problem
2. Collecting the information
3. Generation of multiple solutions
4. Analyzing and selecting a solution
5. Testing and implementation of the solution

First step of the design process starts with defining the problem. This mainly depends on the customer requirements and how much it is needed in the society. The perceived need may not be the real need. Enough information should be collected before dealing with any detail of the design.

The next step, therefore describes the collection of the data related to the features of the product to be designed. Information regarding product specification like size,

shape, material to be used etc. is gathered to further design the product. Also, a survey should be carried out for the availability of the similar product at this stage.

Once the details of the design are identified, the design team generates various alternative solutions. Based on the compatible cost, safety, and other criteria, various other alternatives are selected.

The next step is to analyze the solution selected. Detail analysis enables to reach to a conclusion to decide the alternative that best fits the design of the product. The next step includes development of the prototype on which tests are performed to verify and modify the design further. If the solution chosen doesn't work than the previous steps are repeated and Continuous iterative process is carried which is shown in the design process in Figure 2.2 below [8]:

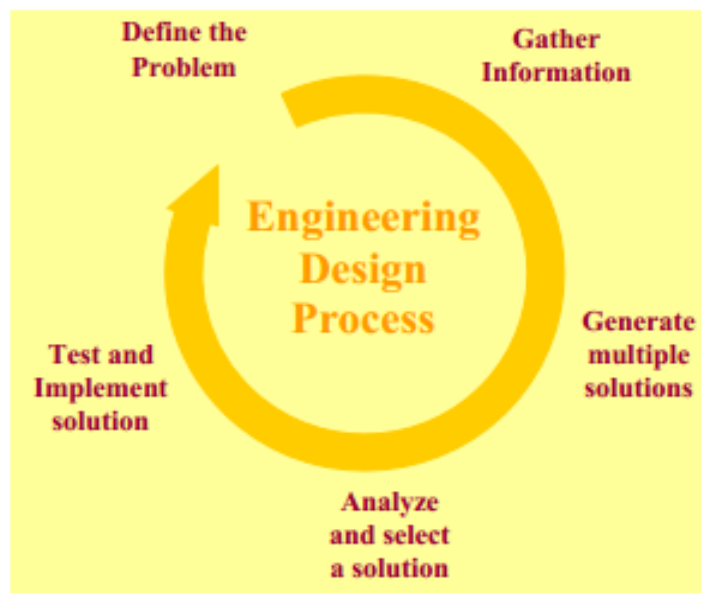

*Figure 2.2: Continuous Design Iterative Process [8]*

### 2.3 *Factors to be considered in Machine Design*

There are many factors to be considered while solving a design problem. Some of the factors to be considered are as follows [9]:

- **Material:** Material plays a very important role while designing. If a wrong material is selected, it tends to fail. Material should be chosen based on how the manufacturing has to be carried out and also depends on the budget.
- **Load:** Stresses must be determined accurately as it is responsible for the internal stresses. Different types of loads are static load, dynamic load, etc.
- **Size, Shape, Space Requirements and Weight:** Size, shape, space and weight are very crucial factors that should be taken care of. If the size of the component is too large than required, it will occupy more work space area and might also result in a high cost. Weight mainly depends on the selected material.
- **Manufacturing:** A feasible manufacturing process suitable to the design of the component must be implemented.
- **Operation:** The operation of any component should be as simple as possible. For example, usage of knob or a switch easily starts the machine. In some of the cases number of operations has to be done to get the machine started. The sequence of operating a machine should be designed in such a way that it is user-friendly.
- **Reliability and Safety:** The designed component should work effectively without facing any failure while operating it. Proper analysis of the machine should be done prior to check for its reliability. Excessive heat generation, overloading, wear of elements should be avoided for the proper functioning of the component. Safety is the other important thing that should be taken care of.

- **Maintenance, Cost and Aesthetics:** Maintenance and safety are linked to each other. If the machines are maintained well in a timely fashion, they will be safe to use resulting in low maintenance future costs possible. Cost of the machine should not be too high or too low. The overall cost of the machine depends on the selected material, machine design and components, and manufacturing process. Aesthetic features are not necessary for machine unless they serve a purpose.

## *2.4 Manufacturing*

Manufacturing is the economic term for making goods and services available to satisfy mankind's needs and for their welfare making life easier. It involves series of operations such as [10]:

- **Product Design and Development:** The first step starts with product design and development. At this stage, decisions are made as to how the product should be made and on the detail design and the production engineering.
- **Material Selection:** There are certain principles to be kept in mind while selecting material. After deciding on product design and development, material is to be selected keeping in mind the important properties such as creep, ductility, fatigue, tensile strength, etc.
- **Process Planning:** Process planning is also called manufacturing planning, process engineering etc. It includes the planning of the process and parameters to be used to manufacture a product. It includes all the detail work and instructions to produce a part. It describes material selection, sequence of operation, usage of special tools like jigs, fixtures etc.

- **Inventory Control:** Inventory control involves looking over supply, storage and availability of items in order to make sure that there is enough supply of raw material.
- **Quality Assurance:** Quality check is the important step after manufacturing the product. It is a way of preventing defects in manufacturing products. It is applied to products in pre-production to make sure it meets all specifications and requirements.
- **Marketing:** Marketing is a very important link between customers need and product design. Marketing plays an important role in designing any product according to the needs of the customer. It also helps reducing the total cost and also gives satisfaction to customers.

## 2.5 *Manufacturing System*

The system that produces useful products is called a production system.

Production can be considered as a process where the set of input is given to increase goods or services. Manufacturing system is the heart of the system where input can be raw materials and finished product serves as the output [10]. Manufacturing processes are collected together to form a manufacturing system in an input-output system which is shown below in Figure 2.3:

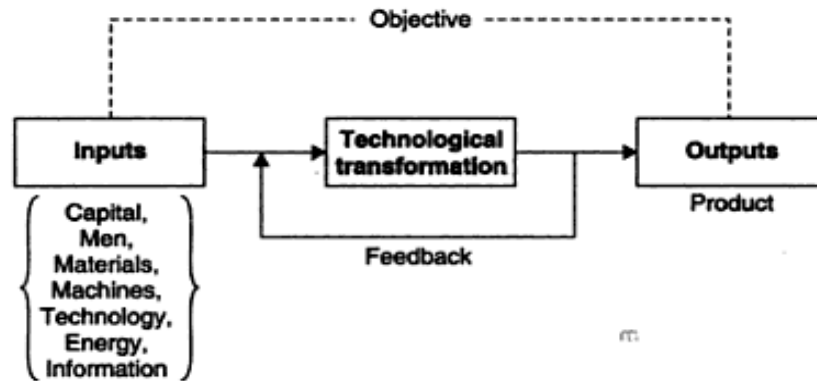

Figure 2.3: Manufacturing as an Input-Output System [10]

**Design rules for manufacturing [10]:**

1. Development of a modular design should be given most importance.
2. Usage of minimum components should be done.
3. Part variations should be minimized to reduce the part complexity.
4. Components that serve multiple purposes should be proposed.
5. Parts that can be easily manufactured should be designed.
6. Emphasis should be given to use standard parts or readily available parts
7. Parts should be produced that can be easily assembled.
8. Detailed dress up features such as chamfering, unnecessary radiuses, tapers etc. should be avoided to avoid the manufacturing complexity
9. Evaluation of assembly sequence should be given more importance to increase the efficiency.
10. Components should be easily accessible for easy maintenance work.
11. Flexible components should be avoided which are difficult to use in automated assembly.

12. Intolerance of parts should be allowed to reduce the cost of the product.
13. Vendors and suppliers should be chosen wisely who are known for their quality work and who are trustworthy.
14. Values of stress should be reduced for parts to increase their reliability and strength.
15. Sub-assemblies of the product should be minimized to reduce the complexity and part count.
16. New methods and technology should be used only when required to reduce the cost of manufacturing the product.
17. Designing components for symmetry from end to end and about axis insertion.
18. Simple operations should be used whose capability is known to reduce the trouble when manufacturing the product.

Manufacturing is a crucial part of this thesis; therefore significant amount of research was conducted to find the best possible manufacturing process for the Mecanum Wheel.

## **2.6 *Finite Element Analysis (FEA)***

After producing the prototype, it undergoes certain analysis to check for its certain properties. It can be applied to many different areas. For example, it can be applied to different structures such as beam, bridge, etc. It can also be applied to mechanics such as gear, powertrain, etc. Finite element analysis is carried to check displacement, stresses and strain at each material point when force is applied. Various functions such as mass, volume, temperature, stress, strain, displacement etc. can be



measured by using FEA software. Various types of analysis can be done with the help of FEA software such as, structural, vibrational, fatigue and heat transfer analysis.

### **How does FEA work?**

FEA consists of a computer model that is stressed and analyzed for specific results. The solid which has to be analyzed is discretized first and then meshed to break it down to number of small elements. Solid model is then fixed at certain points according to its movement and load is applied to the model where required. The analysis is then performed to achieve the displacement, stress, strain, fatigue etc. This analysis helps to decide whether or not the design is feasible in terms of function. FEA analysis of bridge and a car is shown in the Figure 2.4 and 2.5 below [11]:

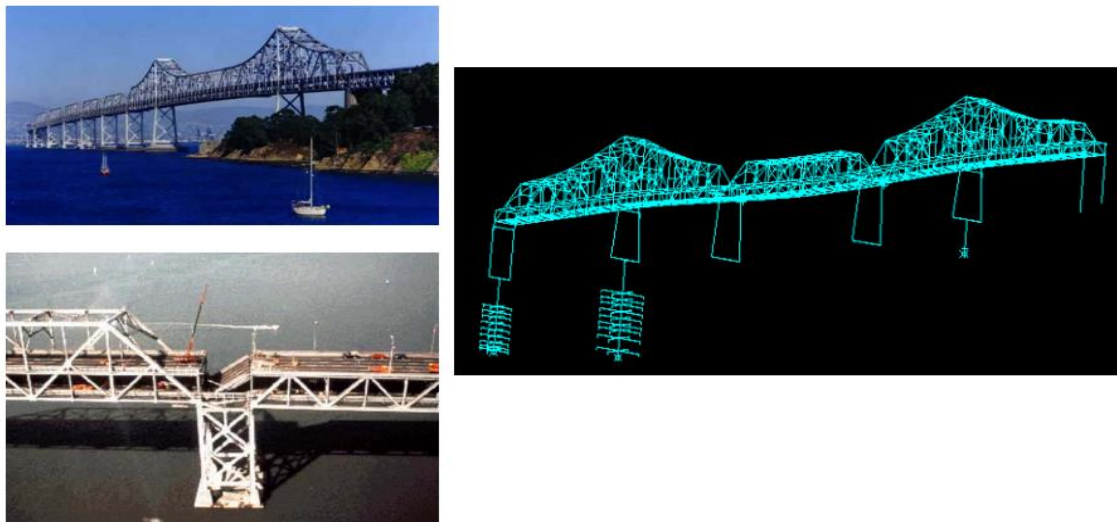

*Figure2.4: FEA Simulation of the Damage of San Francisco Oakland Bay Bridge Caused by the 1989 Loma Prieta Earthquake [11]*

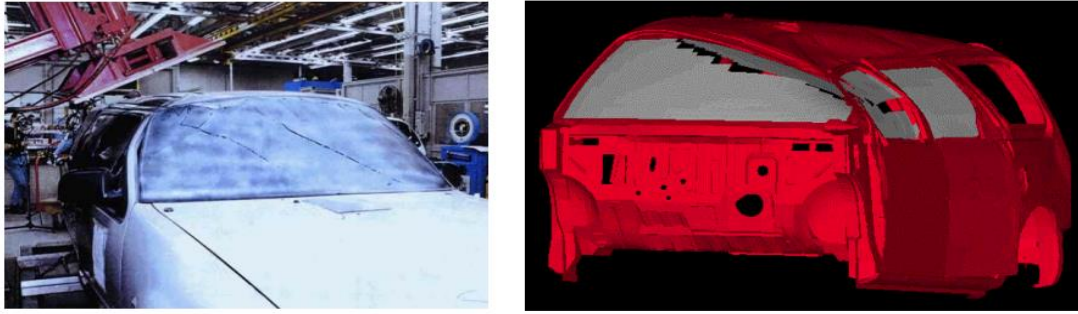

*Figure 2.5: FEA Simulation of Crush of a Car in Roll-Over Situation [11]*

Meshing of the designed product plays an important role which defines how the designed model will react on applying load [12]. FEA is just not a mean to verify the safety of the designed product but also a solution to revise the design if it fails while analyzing. Analysis can be performed with the use of different software such as NASTRAN, ANSYS, SIMULA, ADINA, etc. This software is interlinked with CAD software such as CATIA, Solid works, PRO/Engineer, etc.

FEA plays an important role for this thesis too. After designing Mecanum Wheel, next step is to analyze it before manufacturing it. Load will be applied on Mecanum Wheel and different properties are verified. FEA proves to be a solution to re-design the designed product if it fails to withstand the predetermined load.

## **2.7 Factor of Safety (F.O.S)**

There are uncertainties in the real world problems but F.O.S is one of the ways to control the failure of the designed product up to certain extent. F.O.S can be used in many ways out of which some are [13]:

1. To reduce allowable strength such as yield or ultimate strength to a lower level, to compare it with applied stress.
2. To increase the allowable stress to compare it with allowable strength.
3. To compare the ratio of allowable strength to the applied strength.

$$F_s = \frac{\text{Allowable Strength}}{\text{Applied Stress}}$$

$F_s$  denote the factor of safety.

## 2.8 *Computer Aided Design*

Computer aided design uses computers to develop, analyze or modify an engineering design. Reasons for implementing CAD are [14]:

1. **To Increase the Productivity of the Designer:** By using CAD, the designer can visualize the product and its components sub-assembly and parts. Using CAD productivity can be increased and also design cost can be reduced.
2. **To Improve the Quality of Design:** Design errors are reduced due to the accuracy of the CAD system.
3. **To Enhance Correspondence through Documentation:** Usage of CAD provides better documentation for the product design and few design errors.
4. **The Process of Documenting:** the product design requires database to manufacture is created which can be applied for several computer integrated manufacturing applications like CNC programming, programming of robots, process planning, etc.

In order to design using CAD software, it is necessary to understand what CAD is unable to do.

## 2.9 *Structural Design Optimization*

Optimization is a very important step to design a product. The basic idea is to design the product in such a way so as to decrease the cost and material usage but keeping in mind to increase their performance and durability. There can be multiple options to select a feasible design; only the design having minimum cost, mass, F.O.S, maximum performance is chosen [15].

After designing the product in CAD software, it is analyzed in one of the FEA software for the measurement of its safety. The availability of high performing computers and FEA software has together made it possible to use structural analysis with numerical optimization, which is structural optimization. The main goal for this thesis is to minimize the mass by minimizing the thickness of the Mecanum Wheel plate.

# CHAPTER 3

---

## MECANUM WHEEL DESIGN DEVELOPMENT

### *3.1 Proposed (New) Design Solution*

The main idea behind re-designing the Mecanum Wheel is to reduce the current issues. The new designs include number of concepts out of which the most feasible design is selected. The Mecanum Wheel plate is innovatively designed keeping in mind to design it differently than the patented wheel design. The main challenge was to think innovatively and design something different than the already optimized design.

Firstly the plate design was sketched on a paper to get an idea of how it would look on designing it. CAD software CATIA has been used to design the wheel due to its vast designing workbench. It has been used due to its mechanical design feature, which includes: part design, generative sheet design and assembly design. Due to the complexity of the Mecanum Wheel, generative sheet design workbench is used for creating features at an angle on circular edge. The rollers are sandwiched between two plates at 45 degrees angle and hence the generative sheet design, GSD feature works perfect which allows implementation of curved structures on circular surface. Finally, assembly design attribute is used to combine all individual designed parts. Each concept of the design has been evaluated based on the optimized design.

The design of Mecanum Wheel proposed by AndyMark is the most optimized design, but various flaws have been noticed in it. To reduce these flaws re-designing of the Mecanum Wheel has been done for this Thesis study. All AndyMark Mecanum Wheel designs and description regarding it is described in current chapter. Different

concepts of Mecanum Wheel designs, designed using CATIA software are described further while comparing it with AndyMark designs.

### 3.2 *Plate Concept 1*

Starting with plate concept 1 which is designed in CATIA and is compared with Mecanum Wheel plate manufactured by AndyMark which is also shown in Figure 3.1 [3]:



*Figure 3.1: Plate Concept 1 Designed in CATIA & AndyMark Wheel Design [3]*

The main idea behind designing the first concept is to understand and roughly estimate the design proposed by AndyMark. The first concept is just the primary step to design wheel plate that serves same function as that of the AndyMark wheel plate but with different design features.

The following steps show the design procedure:

- Firstly, shaft is generated in part design workbench by sketching the basic part profile. The diameter is assumed roughly around 6 inches.
- Using surface design workbench tooth is constructed using basic features.
- Manipulation of surface tools to get the tooth at an angle.
- After designing the tooth, it is used to generate teeth throughout the whole plate.

- Extrusion is not done at this primary stage as the main emphasis is laid on designing the tooth first at a right angle.

Also, at this stage dimensions are not accurate. The thickness is not uniform throughout the wheel plate. The advantage of this design is that it weighs less because of thin metallic plate design. Also, the downside of the design is that, it being a primary design angled extensions are not attached to the main body. This was the first step to get the base plate ready with the teeth throughout the circumference of the wheel plate.

### 3.3 *Plate Concept 2*

The main objective of the second concept was to observe the feasibility of a single block design for the rollers. The Figure 3.2 below represents the plate concept 2 designed in CATIA which is compared with the wheel proposed by AndyMark.

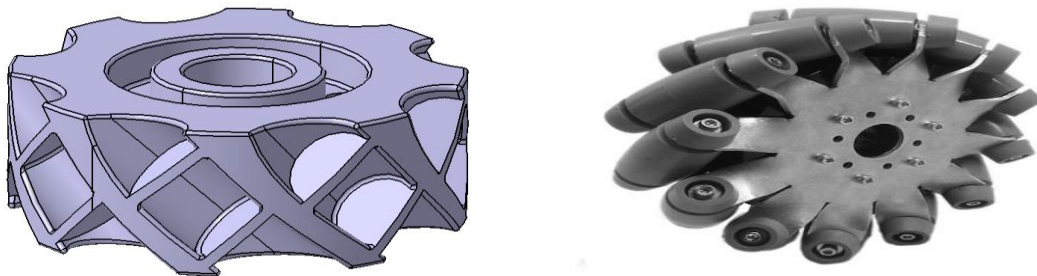

*Figure 3.2: Plate Concept 2 Designed in CATIA and Mecanum Wheel by AndyMark [3]*

Wheel plates with different type of rollers have different advantages. Plate concept 2 utilizes tri-rollers instead of simple rollers. The advantage of tri-roller is that they have large surface area which means that the surface contact between roller and the surface will be much larger. This helps when there is a slippery surface where extra

friction can be obtainable. Also, it is designed in such a way that there is no sub-assembly and because of which there are no complications to attach plates. The drawback of the design is the weight and the manufacturing complexity faced because of angled teeth.

Comparing the plate concept 1 with the plate concept 2 it can be seen that due to the complexity of the plate it will need to be manufactured using automated or semi-automated machine such as computer numerical control etc. Material has been removed from a cylinder of similar dimensions to obtain this concept. The difficult part of removing material is from section where middle roller is supposed to fit. The following steps describe design procedure:

- Solid cylinder was generated in part design workbench. Wheel is designed keeping in mind the outer diameter that has been used by AndyMark which is 6 inches.
- Plane is created at 45° angle. At 45° angle circle is drawn at the circumference of the cylinder and is used to make a pocket of 0.972 inches diameter.
- Three different sections of pocket are drawn around the circumference keeping the circle as the base to account for the tri-wheel design.
- The wheel is circular patterned to replicate the pocket design around the circumference.
- Additional features such as holes are designed to mount the plate on the hub. Also, chamfering is done to smooth the surface.



### 3.4 Plate Concept 3

To deviate from concept 2 which requires large amount of material, a simpler design is employed. This concept is proposed just to design a tooth at the circumference of the wheel plate at right angle. This design also cuts down the weight because of less material used. Also, simpler fittings where the rollers are to be attached are designed for plate concept 3. Designed plate concept 3 is shown in Figure 3.3 below.

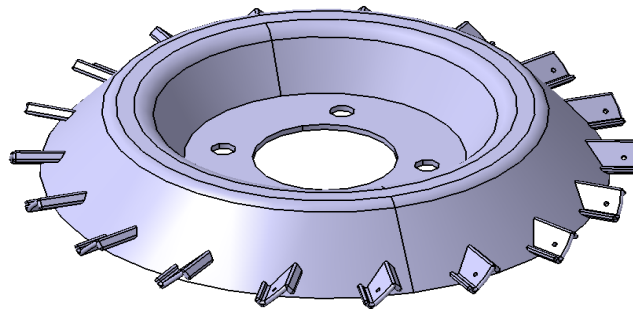

*Figure 3.3: Plate Concept 3 with Teeth at an Angle Designed in CATIA*

One of the drawbacks of this design is that the angled extensions will need to be attached to the main body separately. This adds some complications because the angled sections have to be attached by riveting which could create complications. The following steps describe the design procedure for plate concept 3:

- Shaft design is directly proposed from plate concept 1.
- Tooth is designed while extruding the design in generative sheet design feature.
- Teeth are generated after designing it and circular pattern is used to create teeth throughout the circumference.
- Finishing operation is done for holes and bends.

### 3.5 *Plate Concept 4*

The entire proposed concept is designed to achieve the most optimized design. To avoid complications faced in previous concept, a design which could be stamped from a metal sheet is investigated in the present concept. The only downside of this design is the sharp edges in the wheel plate. This design proved to be a success so far and which is also different than the AndyMark wheel plate. Designed plate concept is shown in Figure 3.4 below:

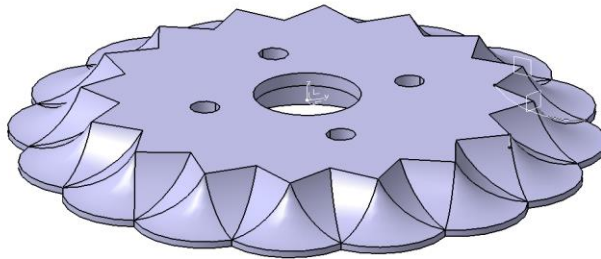

*Figure 3.4: Plate Concept 4 Designed in CATIA*

The following steps describe the design procedure for plate concept 4:

- The designing starts with generating the circular plate in part design.
- Cutout is made to give pointed edges which extrude extra material.
- The designed edge is circular patented throughout the circumference.
- Generative sheet design is used to design the teeth at the sharp edge of the plate.
- Sharp teeth are connected to the curve of the circular plate to generate it.

### 3.6 Plate Concepts 5 and 6

Different design is proposed for concept 5 and 6 which deviates from the design proposed for concept 4. This design utilizes same base plate as concept 4. Concept 5 is the primary idea but weight is saved after removing enough material which is done in concept 6. Instead of curved teeth, a straight tooth is designed for these concepts. Tooth is also closed with a solid triangular shape. Figure 3.5 below shows both concept 5 and 6.

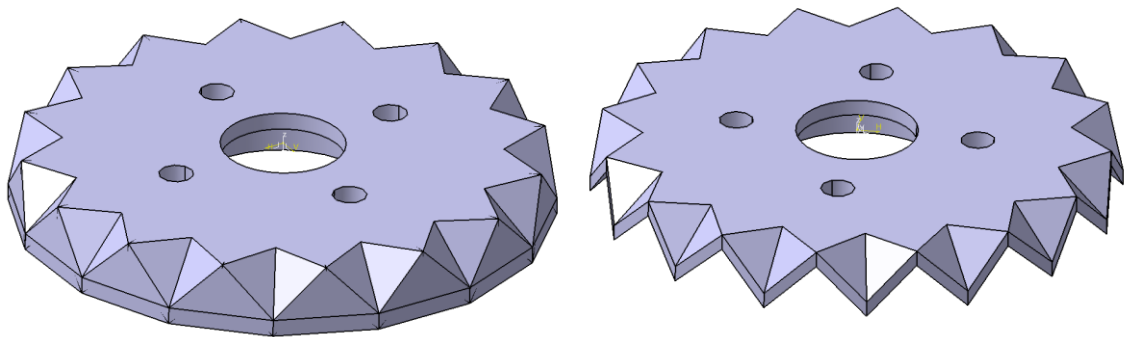

*Figure 3.5: Plate Concept 5 and Plate Concept 6 Designed in CATIA*

Overall it can be concluded that the current wheel structure is different than concept 2 which is a single part and also fits the rollers on its own. All other concepts of wheel plate require two plates per wheel to support the rollers. Hence, all other plates need to be welded, riveted or bolted together, except the second concept as shown in Figure 3.5. For the wheel concept that require 2 plates, a spacer needs to be employed between the plates or integrated bends in the plate to ensure proper roller spacing and to transfer axial loads from the bolts to both plates without pinching or crushing the rollers. Also, all other concepts have sharp angles in the design, except the second concept.

Machined parts need a minimum radius of curvature for the material. There is a lot of extra material around the 4 hub pattern holes. This area can be examined again for weight reduction. The outer portion looks like it could be stamped if a tool radius is applied to the sharp edges. The entire plate can be stamped just with the little modification to the center. Another option is to have two stamped plates with a spacer in the center for proper plate spacing so that the body of the wheel would consist of 3 parts. All these points are taken into consideration to reach the final design keeping in mind to eliminate all the drawbacks.

### *3.7 Wheel Design 1*

Figure 3.6 below, shows the wheel design 1 which is obtained from concept 6.

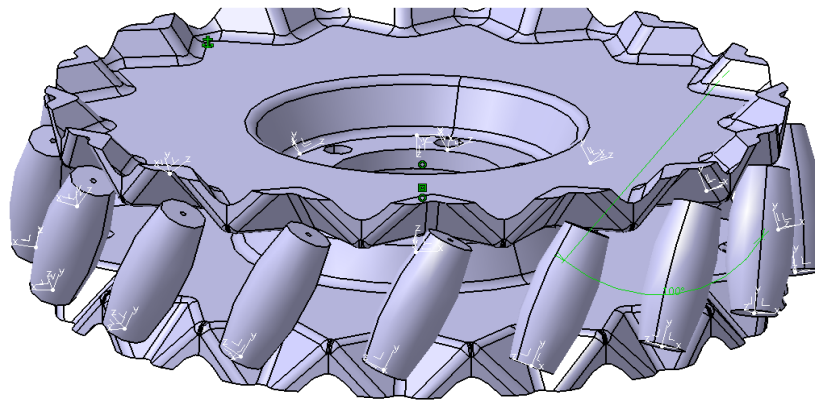

*Figure 3.6: Mecanum Wheel Design 1 Designed in CATIA Using GSD Workbench*

When, compared with concept 6 the plate used for Design 1 involves curved surfaces as well as it involves elimination of all sharp edges. The result is the wheel which utilizes 16 rollers and two plates designed previously. The plate design from

concept 6 is inverted to allow the possibility of the weight reduction. This is achieved by shaving off the pointed teeth of the plate.

Main idea of this design is to emphasize the edge fillet of the plate on both the top surface and bottom surface. Also, edges are smoothed in part design. At this stage considerable gap is seen between rollers which are not designed at this stage. Rollers from AndyMark are used to create a design which would give overview of the Mecanum Wheel. The plate design from concept 6 is inverted to allow the possibility of the weight reduction. This is achieved by shaving off the pointed teeth of the plate.

The advantage of this design is that there is enough flexibility for tooling with the curved edges. Furthermore, the plate can be stamped which is desired for Mecanum Wheel.

### 3.8 *Wheel Design 2*

This design is similar to plate concept 5 with some minor changes and is also shown in Figure 3.7 below.

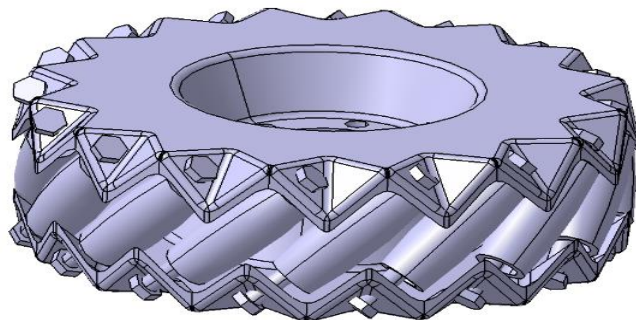

*Figure 3.7: Mecanum Wheel Design 2 Designed Using GSD and Part Design Workbench*

The main idea behind designing the above Mecanum Wheel was to make sure that the roller contour was sticking out enough so that there could contact with the surface. Previously, the emphasis was only given on designing the different wheel plate and then concentrating on the wheel rollers. But, for this wheel design also the rollers are assembled with the wheel plate to get a proper idea about the complete wheel structure. Also, this Mecanum Wheel is designed using both part design and generative sheet design. The bolts were implemented after placing the rollers at the desired location. Unlike the current design, this design cannot just be rotated 180° to fit around the plate. Hence, the plate at the bottom needs to be rotated until it is lined up with the rollers. This was the main idea behind designing the above design.

### **3.9 Wheel Design in GSD**

For the design which is done in GSD workbench, rollers and plate are designed in part design while flanges are designed in GSD workbench. All this parts are assembled to get the full assembly.

#### **Design Procedure for Rollers**

As mentioned, rollers are designed in part design. The following steps describe the roller design procedure:

- First, using the sketch feature outer roller body is designed.
- Shaft profile is designed in part design workbench which is then generated as a full solid.
- A circle is then created and after that pocket feature is used to create hole by removing material.

- Roller is rotated at an angle of 45 degrees. Circular pattern is created which generates 16 rollers in total.

The design profile of roller in CATIA is shown in Figure 3.8 below:

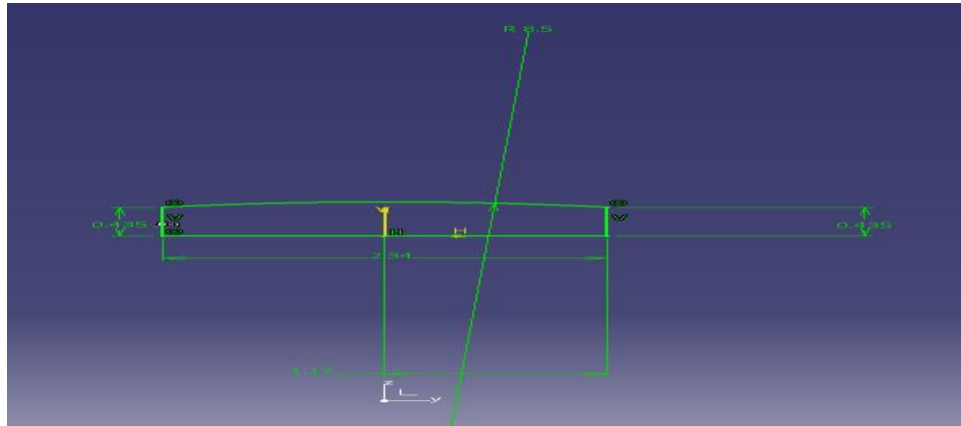

*Figure 3.8: Roller Profile Designed in CATIA*

As seen in diagram the roller dimension are as follows:

Width: 0.435 in.

Length: 2.34 in.

Radius of curvature: 8.5 in.

After generating the roller pattern it is realized that there is overlapping of rollers which is not desired in Mecanum Wheel. Efficiency of wheel decreases because of bumpiness which occurs due to the overlapping of rollers. This overlapping of the rollers is corrected by affinity feature which is available in CATIA. This feature has been used to reduce the overall size of the rollers by 33%. This value of reduction has been selected after trying different values and has also proved to be beneficial as overlapping could be

eliminated. Figure 3.9 below represents the circular pattern of the rollers which does not involve overlapping.

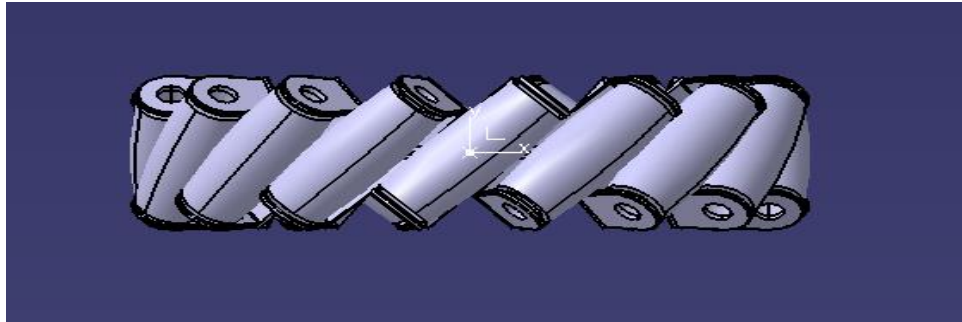

*Figure 3.9: Circular Pattern of Rollers Created in CATIA*

### **Design Procedure for Plate**

The following steps describe the design procedure for wheel plate:

- Designing of plate starts from outside and gradually moves towards the center of the plate which means designing the flanges first which holds rollers and then moving towards the hub of the plate.
- A plane is created at the end of the roller where the flange design is drawn. The flange design is drawn while maintaining the thickness of the plate which is 0.0625 inches.
- An allowance of 0.05 inches is given between the roller and the flange where the roller is attached.
- Close surface feature is then used to create a solid flange. Edge filleting is also done to avoid the sharp edges.



- Flange is circular patterned keeping the instance same as the number of rollers which is 16. The Figure 3.10 shows the design of flange along with its dimensions from which it can be noticed that the length is 0.394 inches and the dimension of the hole is 0.126 inches.

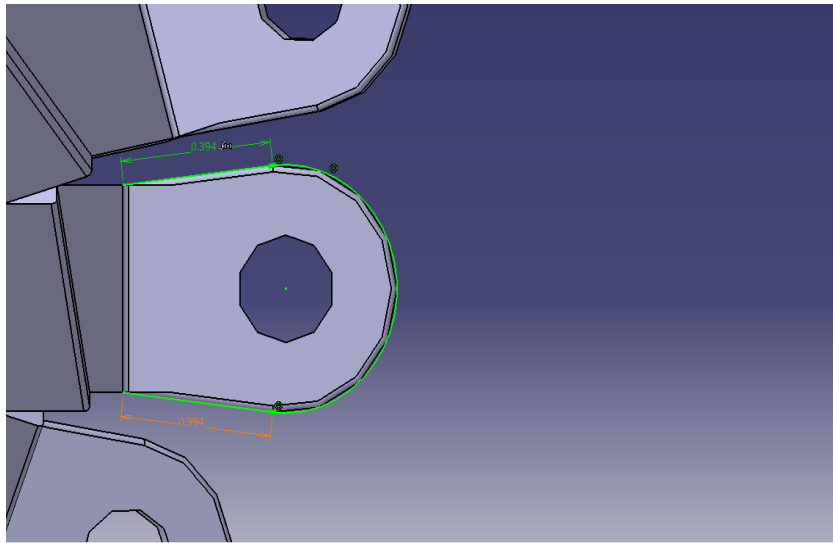

*Figure 3.10: Design of the Flange Along with its Dimensions in CATIA*

- Pad is created in part design of same thickness as that of plate. A quadrant is created on padded area and pocket feature is used to remove the material. It is then circular designed to have 4 such quadrants. The design and the dimension of the pad is shown in Figure 3.11 below which mentions that the circle is of dimension of 3 in. diameter and also the radius of curvature of the quadrant is of radius 1.5 inches which is also shown in the Figure 3.11 below:

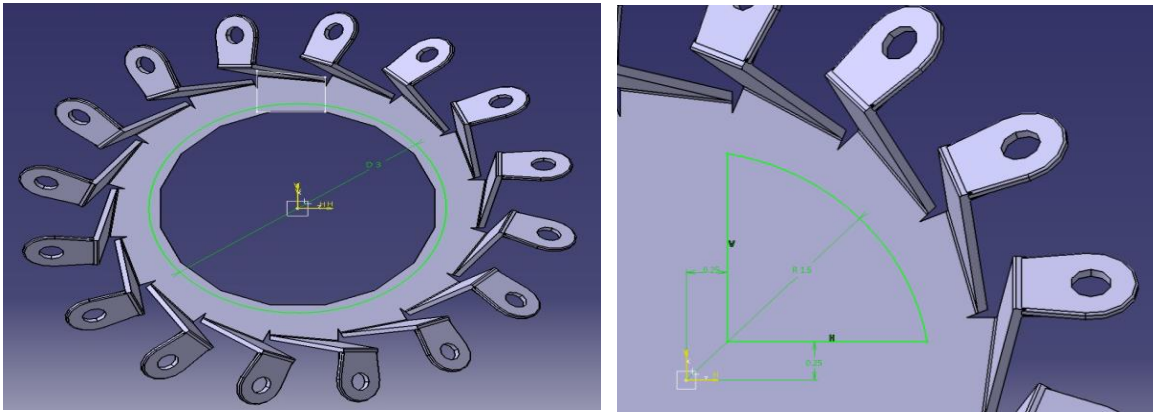

*Figure 3.11: Design and Dimension of Pad and the Dimension of the Quadrant*

After creating all these parts in product design all parts like rollers, flange and plate are assembled. 16 rollers are placed in assembly design feature and the plate is attached while aligning the holes in the plate to the holes in the rollers. A similar plate is also placed at the bottom surface and then aligned with the holes of the bottom part of the roller. The 4 view of the Mecanum Wheel plate is shown in Figure 3.12 below:

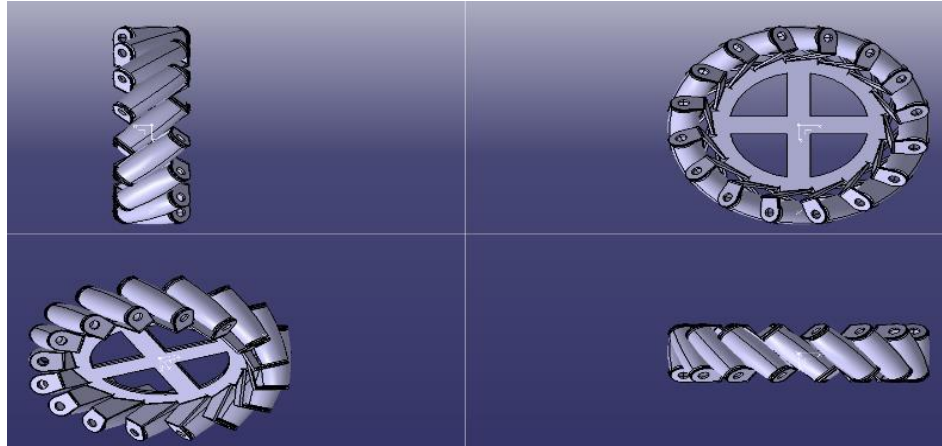

*Figure 3.12: 4-View of Mecanum Wheel Designed in GSD Workbench*

The main advantage of this design is that it is a universal plate design. It is possible to use the same plate on any side of the chassis by just changing the orientation of the plate when mounting it. Because of this wheel plate design, left hand side and right hand side wheel plate manufacturing can be avoided completely.

### **Drawbacks of Wheel Design Created in GSD**

Following are the points which are to be checked while designing the wheel plate in sheet metal design:

- Tabs protrude past the boundary of the rollers. Rollers need to be made smaller by grinding it. At least 0.175 in. (4.4 mm) of clearance has to be given between the tab and roller edge.
- The outer edges of the roller are slightly too large which needs to be taken care of.
- The roller bolts can be made smaller. It looks like M6 or 1/4-20 bolts have been used now. But bolts can be made of size M5 or 10-32 bolts can also work.

- Sheet should not be cut to a sharp point to decrease the probability of crack propagation at those points.
- Bends are too sharp which needs to be reduced by looking at K-factor for minimum bend radius.
- Artifacts near the rollers cannot be made by bending sheet metal, which has to be removed from the design.
- 90 degree bends are seen at the ends of the rollers. This condition may buckle the roller under the load. Two bend from the base plate would provide a better load path through the tabs to the center of the wheel.

### *3.10 Modified Wheel Design in GSD*

For the modified design 1 the rollers designed for previous design are used and only the wheel plates are modified. For modified design 1 the tip of the roller is chosen as reference and the plane is created from the tip at an offset of 0.264 in. the rectangle is created at using the plane created. The Figure 3.13 below represents the plane created from the tip of the roller:

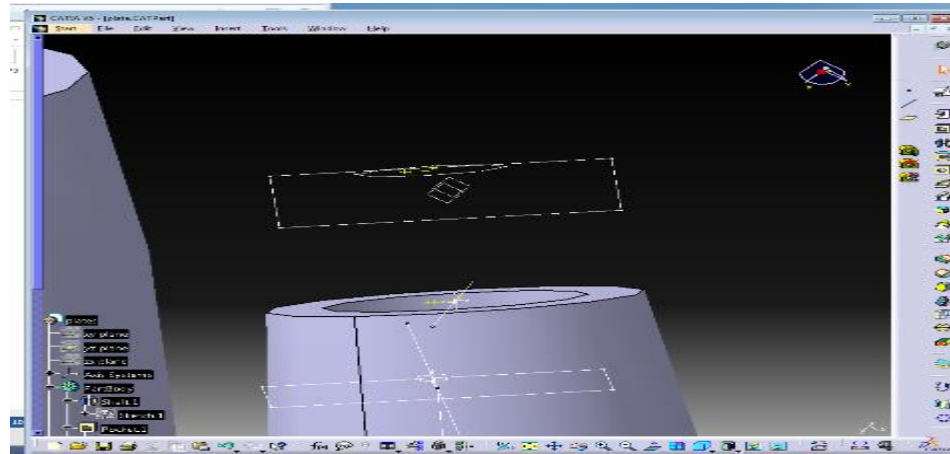

*Figure 3.13: Plane Created at an Offset from the Tip of Roller*

Again, a plane and then a rectangle is created at a 60 degree angle choosing the previous plane as reference which is also shown in Figure 3.14 below:

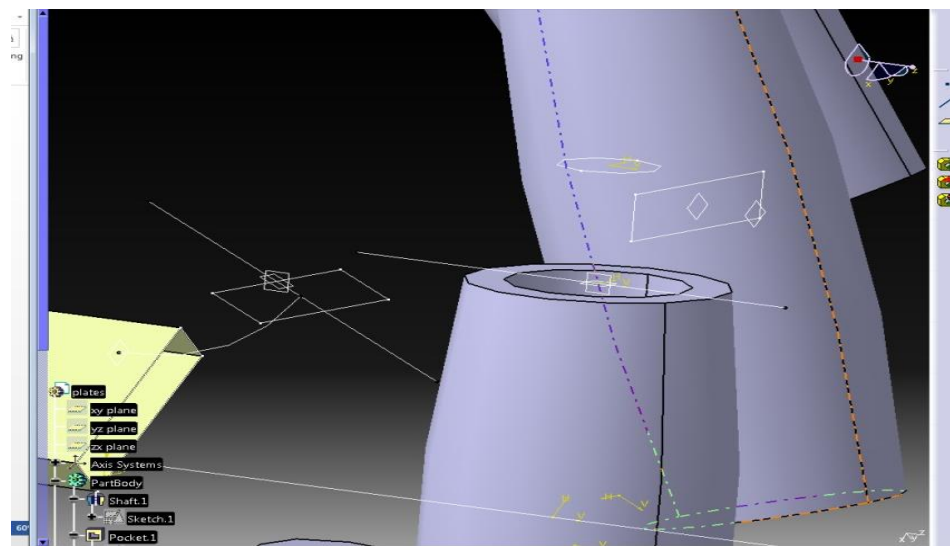

*Figure 3.14: Creation of Second Plane Choosing the First Plane as Reference*

The third plane is created from the original plane at an offset of 1.462 in. from the XY plane and also the third rectangle is created at this plane. All the three planes are shown in Figure 3.15 below:

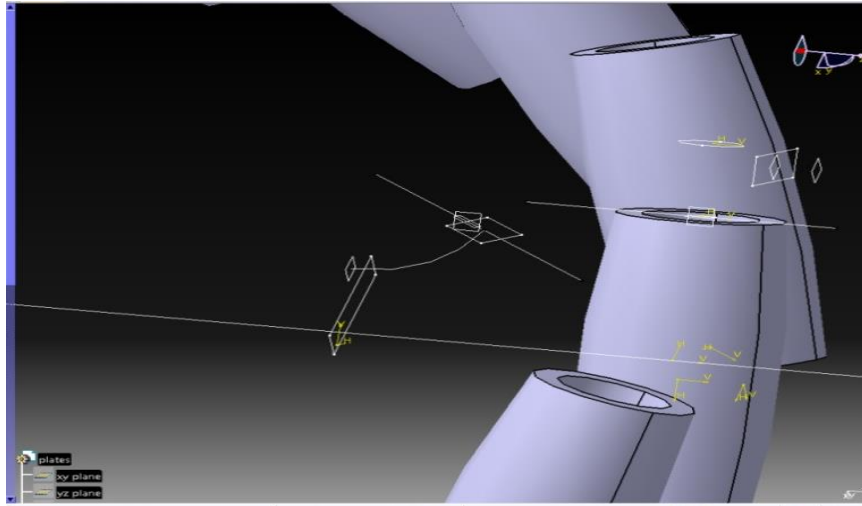

*Figure 3.15: Geometry Showing the Creation of all the Three Planes*

The tricky part of this design is to get the rectangles at right position to form the flange section of the plate. These rectangles are then connected using multi-section surface in GSD workbench. To close the surfaces of the rectangle, fill option is used. The formation of flange is shown in Figure 3.16 below:

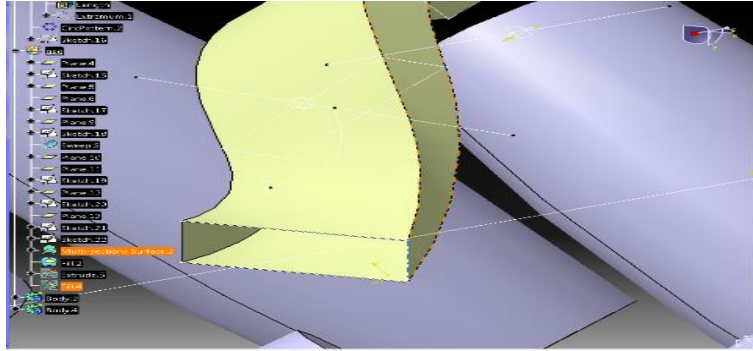

*Figure 3.16: Creation of Flange by Joining the Three Planes Created in Geometry*

For further design, choosing the third rectangle as surface it is extruded by 1 in. in XY plane. To close the extruded rectangle the fill option is used. Later, the join option is used to connect and blend all the rectangles and edges created to form one close feature and which is also shown in Figure 3.17 below:

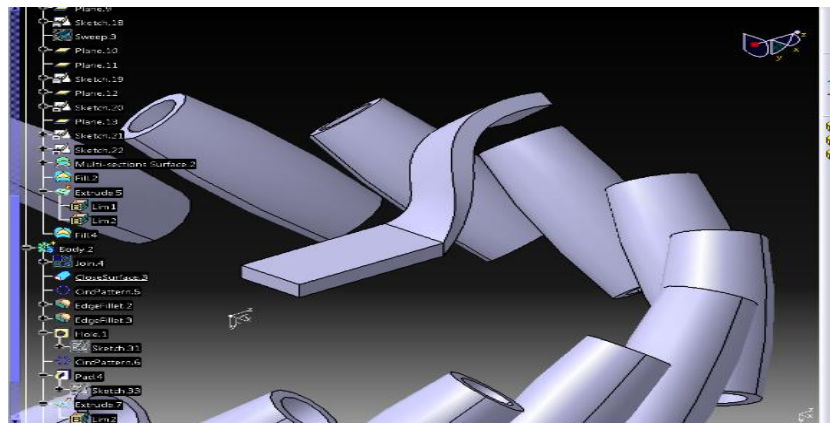

*Figure 3.17: Extrusion of the Rectangle by Creating the Profile*

After using the close surface feature, circular pattern is created and rotated around Y axis. The pattern is created using crown definition at 16 instances keeping at an angle of 22.5 degrees. Edge fillets are applied to remove sharp edges. It is also used to create

round edges for the sharp edge of the flanged part and which is also shown in Figure 3.18 below:

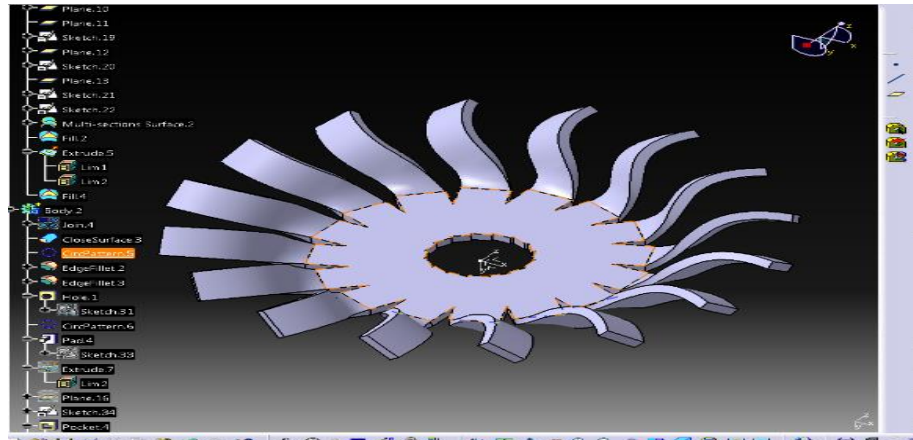

*Figure 3.18: Creation of the Pattern Using the Special Feature Circular Pattern in CATIA*

The hole is then created in the plate and circular pattern is created to repeat the holes to fit in the bolts. Also, the parameter for the circular pattern is shown in Figure 3.19 below:

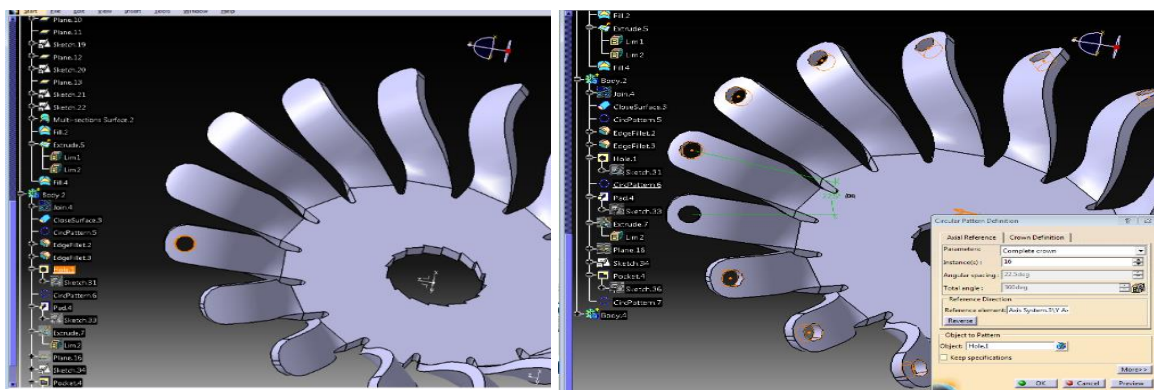

*Figure 3.19: Creation of Hole to fit in Bolts and then Creating Circular Pattern of Hole*



A circle is created at the middle of the plate and is extruded on both the sides of the plate to close the center of the plate which is shown in Figure 3.20 below:

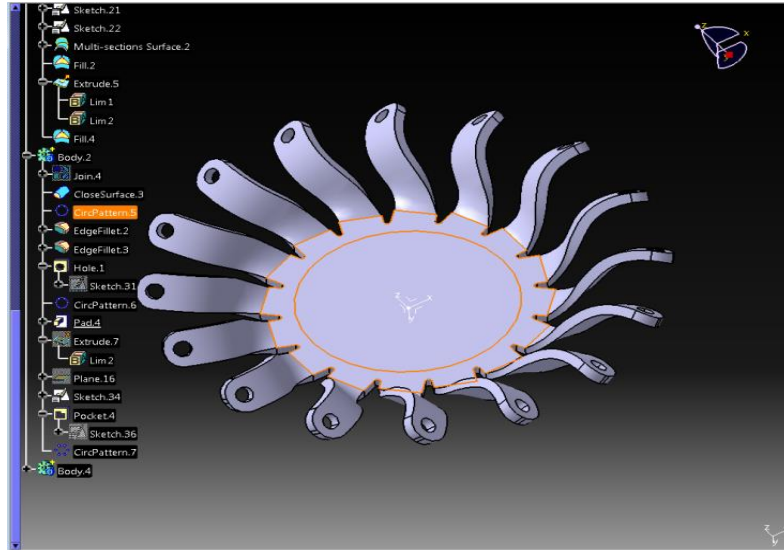

Figure 3.20: Creation of Hole to Fill the Center of the Wheel

Again, a sketch is created and pocket feature is used to remove the material and is circular patterned to make room for the hub and which is also shown in Figure 3.21 below:

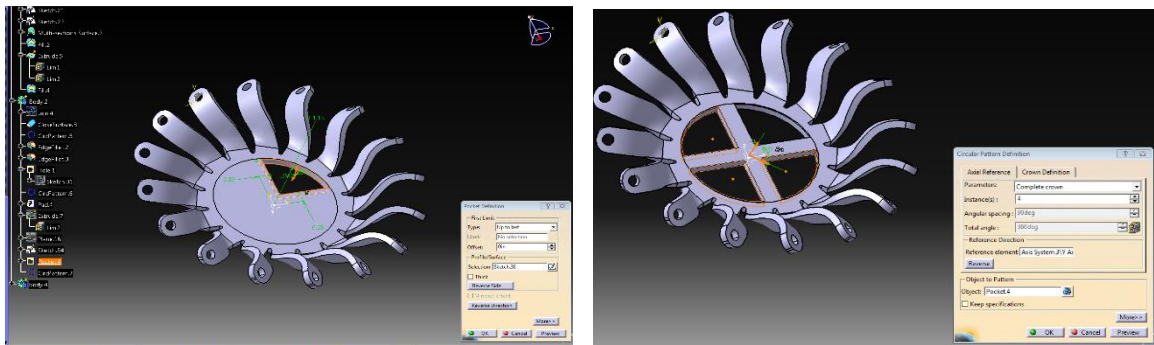
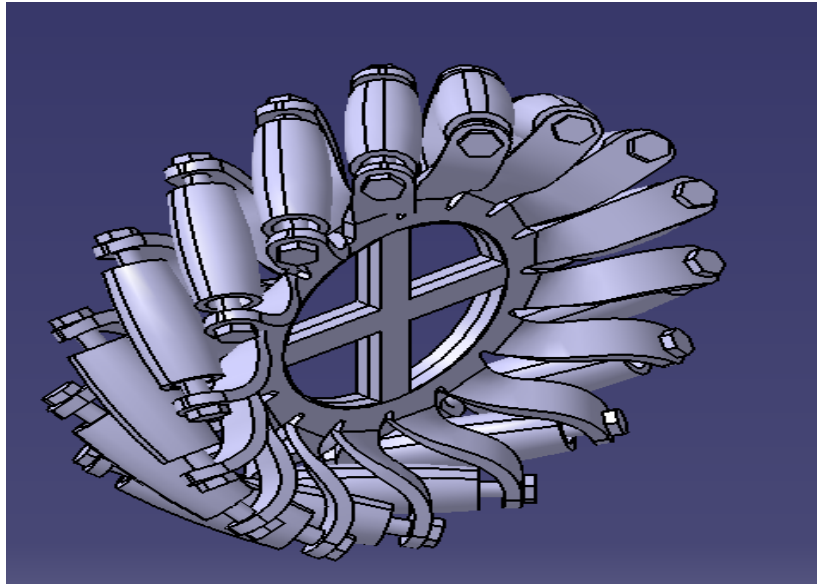

Figure 3.21: Creation of the Pocket to make Space for the Hub

And at last two plates are used to form the wheel structure and the bolts are inserted to create contact between plates and rollers. The complete product is shown in the Figure 3.22 below after assembling two plate, rollers and bolts, etc.



*Figure 3.22: Modified Mecanum Wheel 1 Designed in CATIA*

# CHAPTER 4

---

## FINITE ELEMENT ANALYSIS OF MECANUM WHEEL

### *4.1 Finite Element Analysis*

Structures designed tend to fail by applying larger loads which cannot be withstood by them. They can undergo various modes of failure such as, buckling, brittle fracture, ductile fracture, impact, creep, thermal shock, wear, etc. as well as stress and strain failures [16]. In order to check the feasibility of the structure FEA analysis was performed on the different designs of the Mecanum Wheel by following the steps mentioned below.

The first step is to convert the extension of the CATIA model from CAT product to STP file. The main difficulty faced while working with ANSYS software is that it does not read the CAT product because of which it needs to be converted to different extension file. The main aim is to check the feasibility of the Mecanum Wheel under different loads and conditions. The feasibility of the wheel is checked considering two different materials i.e. Structural Steel and Aluminum.

Analysis is performed on the main designs of the wheel and not the preliminary designs. The first analysis is performed on the wheel design that has been modeled in GSD workbench. After importing the geometry, it is actually generated as it is transferred from CATIA to ANSYS. Analysis done on wheel modeled in GSD is shown in next section.

## 4.2 FEA Analysis of Mecanum Wheel Designed in GSD

To check the feasibility of the wheel structure a plane is created for the wheel to roll to check the force impact on both wheel and plane. The basic idea is to check the feasibility of the wheel while it is rolling and not in static condition. The first step is to assign the material to the structure. Firstly, the analysis is done by assigning Aluminum alloy to the structure. Figure 4.1 shows the properties of the Aluminum material:

Properties of Outline Row 3: Aluminum Alloy				
	A	B	C	D E
1	Property	Value	Unit	
2	Density	0.10007	lb in <sup>-3</sup>	
3	Isotropic Secant Coefficient of Thermal Expansion			
4	Coefficient of Thermal Expansion	2.3E-05	C <sup>-1</sup>	
5	Reference Temperature	22	C	
6	Isotropic Elasticity			
7	Derive from	Young's Modulus and...		
8	Young's Modulus	7.1E+10	Pa	
9	Poisson's Ratio	0.33		
10	Bulk Modulus	6.9608E+10	Pa	
11	Shear Modulus	2.6692E+10	Pa	
12	Alternating Stress R-Ratio	Tabular		
13	Interpolation	Semi-Log		
14	Scale	1		
15	Offset	0	Pa	
16	Tensile Yield Strength	2.8E+08	Pa	
17	Compressive Yield Strength	2.8E+08	Pa	
18	Tensile Ultimate Strength	3.1E+08	Pa	
19	Compressive Ultimate Strength	0	Pa	

Figure 4.1: Properties of Aluminum Alloy Derived from ANSYS

The next step was to combine two plates as one solid using Boolean function. The plane created has the thickness of 1 inch. This object is quite complicated to perform analysis on. The rollers of the wheel placed at 45 degrees which makes the problem more complicated. The next step is to check connection between all the parts of the product. To avoid the loose connections, manual contact is created between three rollers which are in contact with the plane. Practically only one roller is in contact with the plane yet the

roller touching the plane is given the manual contact. The Figure 4.2 below shows the geometry of the Mecanum Wheel connected to then plane generated in ANSYS.

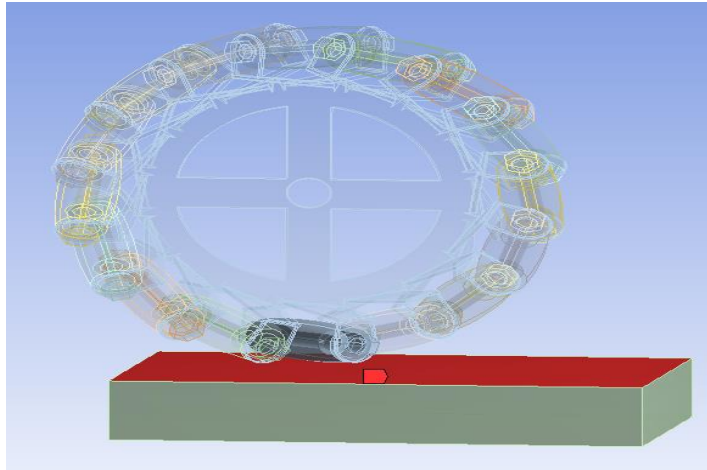

*Figure 4.2: Manual Contact of Roller Created with Plane in ANSYS*

After fixing the connections mesh is generated for both wheel and plane. A fine mesh is generated which is shown in Figure 4.3 below:

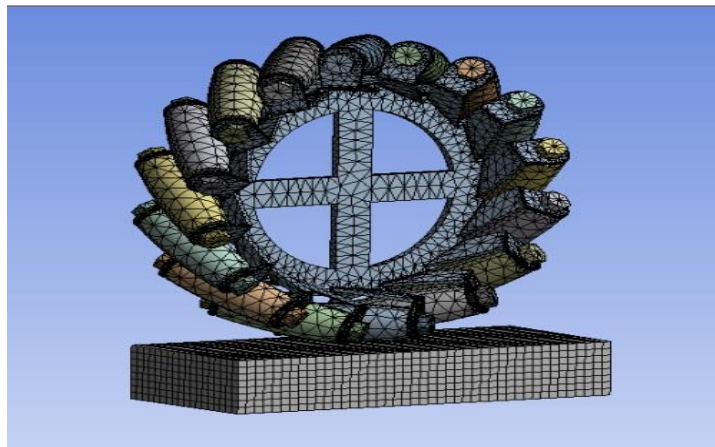

*Figure 4.3: Mesh Generated by ANSYS for Aluminum Wheel*

Also, the specifications given while meshing structure is mentioned in Figure 4.4

below:

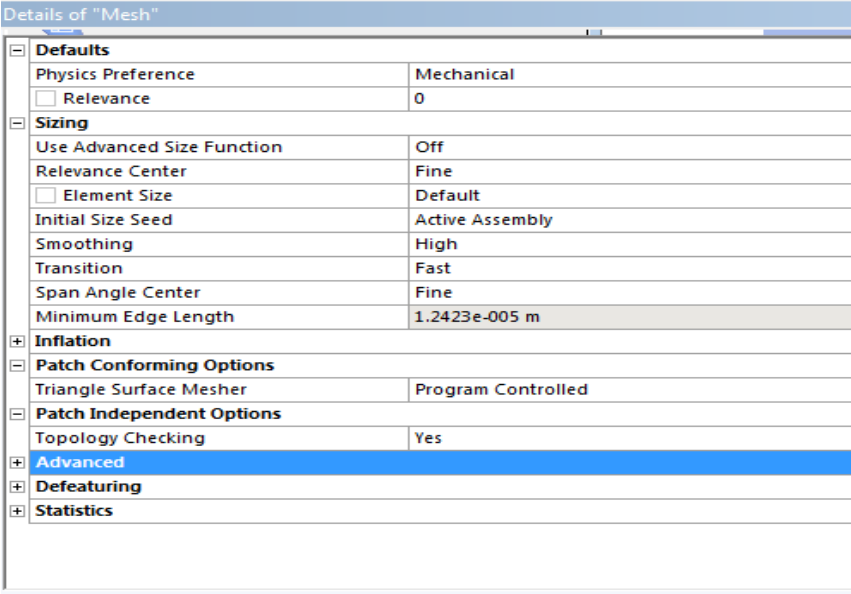
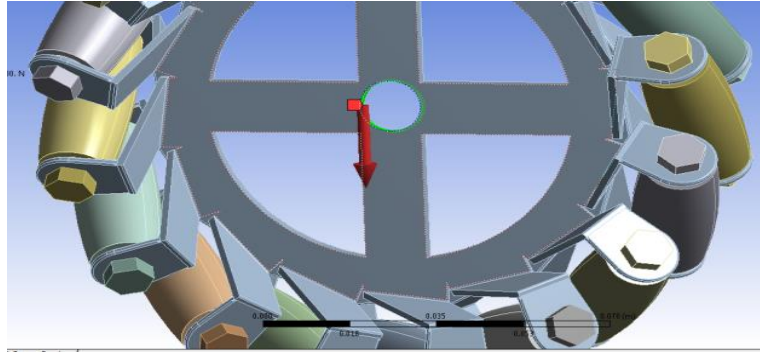

Figure 4.4: Details of Meshing for Aluminum Wheel

The next step is inserting fixed support which is given to the plane which supports the wheel structure. For this thesis static loads are given assuming the wheel at the rest and giving it a force to check its feasibility and the deformation in the body. The hole at center of the plate is where the axle of the chassis is inserted. The force is given to the face of the hole considering all the forces are getting concentrated at the center of the Mecanum Wheel. The Figure 4.5 below shows the application of the force at the five faces:



*Figure 4.5: Application of Forces at the Center of the Mecanum Wheel*

Also, the parameters given for the force are mentioned in Figure 4.6 below:

Details of "Force"	
[-] <b>Scope</b>	
Scoping Method	Geometry Selection
Geometry	5 Faces
[-] <b>Definition</b>	
Type	Force
Define By	Components
Coordinate System	Global Coordinate System
<input type="checkbox"/> X Component	0. N (ramped)
<input type="checkbox"/> Y Component	0. N (ramped)
<input type="checkbox"/> Z Component	7000. N (ramped)
Suppressed	No

*Figure 4.6: Force Parameters Used for the Mecanum Wheel*

The Mecanum Wheel was analyzed for many different loads. The wheel has the load capacity of 200 lbs. Load of 1573.66 lbs. is applied in Z direction to check the deformation. The resulting deformation was very little which proved the structure to be very rigid which could further be optimized. The thickness of plate can be decreased to reduce the rigidity of the structure.

The Figure 4.7 below shows the deformation experienced by the wheel structure when the above mentioned load is applied. The center of the wheel may tend to fail as the load is concentrated at the center of the Mecanum Wheel.

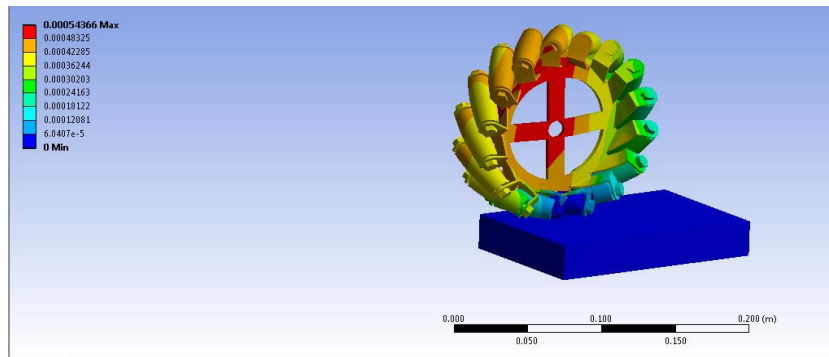

*Figure 4.7: Deformation Noticed in Aluminum Wheel*

The Figure 4.8 below shows the equivalent stress distribution from which it can be concluded that there is equivalent stress distribution:

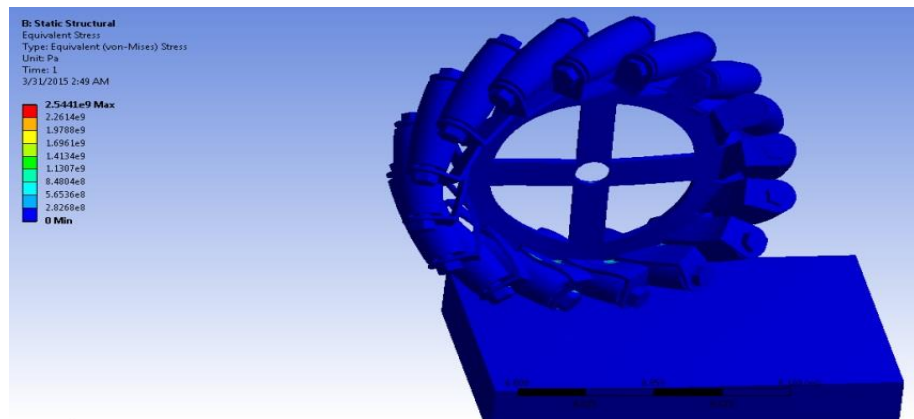

*Figure 4.8: Equivalent Stress Distribution Noticed in Mecanum Wheel*



The Figure 4.9 below represents the safety factor which is analyzed on Aluminum Mecanum Wheel on application of the load mentioned:

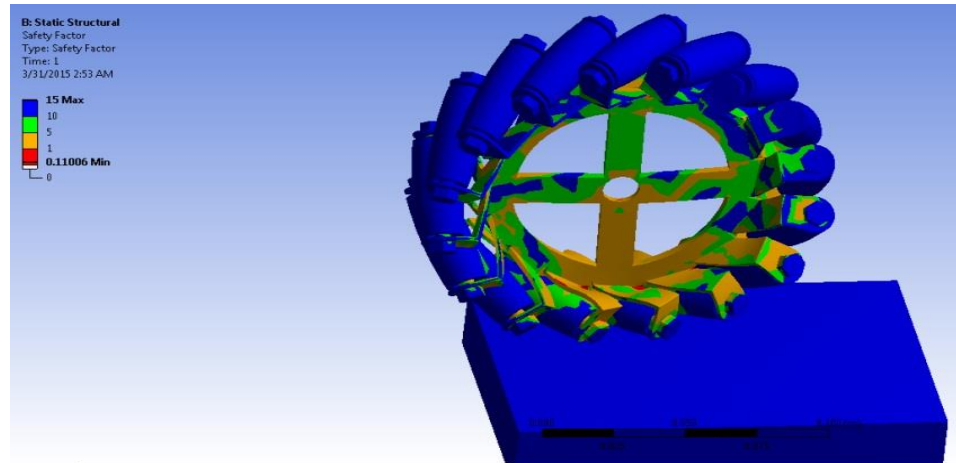

*Figure 4.9: Factor of Safety Calculated for Mecanum Wheel*

From the above Figure 4.9 it can be seen that most of the failure is seen near the edges of the roller because of the sharp edges. Getting rid of the sharp edges can prove to be beneficial to avoid the structure from failure. Due to the structure being over rigid the wheel is safer than required. Optimizing the wheel can solve this problem which should be done as future work.

### **4.3 Finite Element Analysis Using Structural Steel**

The most important difference seen while using Aluminum and the Structural Steel is the weight difference. The weight of the wheel structure is more when using structural Steel. The Figure 4.10 below shows the parameter for both Structural Steel and

Aluminum. Also, the wheel rollers are considered to be made out of Aluminum as problems were experienced using any rubber material.

Details of "Geometry"		Details of "Geometry"	
<b>Definition</b>		<b>Definition</b>	
Source	P:\final hopefully_files\dp0\Geom\DM\Geom.agdb	Source	P:\final hopefully_files\dp0\Geom\DM\Geom.agdb
Type	DesignModeler	Type	DesignModeler
Length Unit	Meters	Length Unit	Meters
Element Control	Program Controlled	Element Control	Program Controlled
Display Style	Body Color	Display Style	Body Color
<b>Bounding Box</b>		<b>Bounding Box</b>	
Length X	7.0195 in	Length X	7.0195 in
Length Y	4. in	Length Y	4. in
Length Z	6.6497 in	Length Z	6.6497 in
<b>Properties</b>		<b>Properties</b>	
<input type="checkbox"/> Volume	34.47 in <sup>3</sup>	<input type="checkbox"/> Volume	34.47 in <sup>3</sup>
<input type="checkbox"/> Mass	9.7756 lbm	<input type="checkbox"/> Mass	3.4495 lbm
Scale Factor Value	1.	Scale Factor Value	1.
<b>Statistics</b>		<b>Statistics</b>	
Bodies	34	Bodies	34
Active Bodies	34	Active Bodies	34
Nodes	80543	Nodes	80543
Elements	41062	Elements	41062
Mesh Metric	None		
<b>Basic Geometry Options</b>			

Figure 4.10: Parameters for Structural Steel and Aluminum Material

All the other parameters are kept same as used for Aluminum material. The analysis is performed and the results are shown below.

The Figure 4.11 below shows the deformation observed in Mecanum Wheel structure when using Structural Steel:

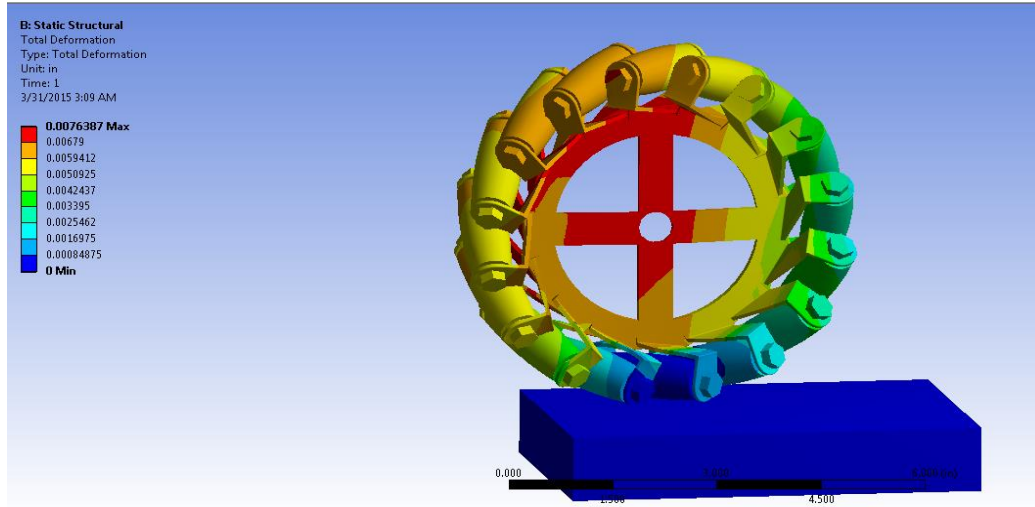

*Figure 4.11: Deformation Seen in the Mecanum Wheel while Using Structural Steel*

The Figure 4.12 below shows the equivalent stress in Mecanum Wheel and from the model it can also be concluded that the structure seems to be safe and also there is equivalent stress distribution except near the roller which is connected to the surface of the plane. To see the change in the stress distribution over the wheel, either more load than the current load should be applied or else the wheel structure should be optimized to make it feasible for the load it has been rated for.

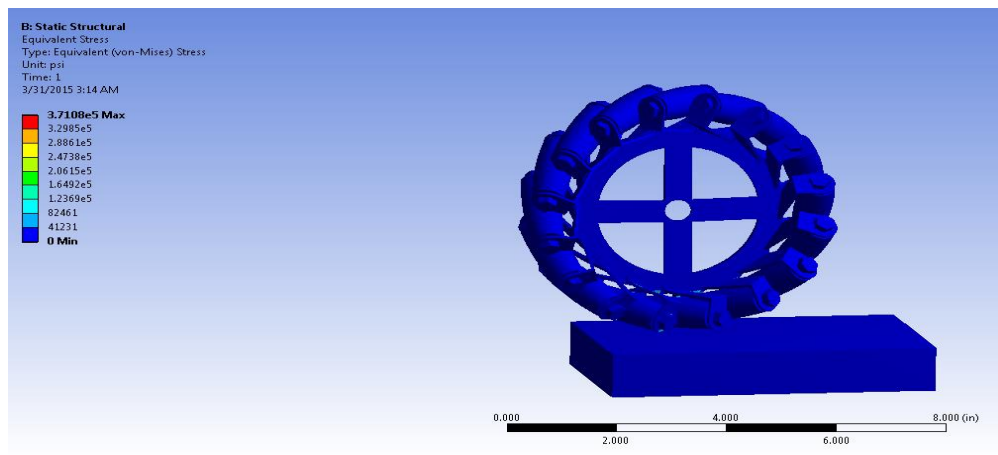

*Figure 4.12: Equivalent Stress Distribution in Steel Wheel*

#### 4.4 *Finite Design Analysis for Modified Design Using Structural Steel*

The analysis is performed on the modified design taking into consideration both the material Structural Steel and Aluminum. Again for this FEA analysis, the Boolean feature is used to connect both the plates and make them one solid body. Also, the mesh is generated which is shown below in Figure 4.13:

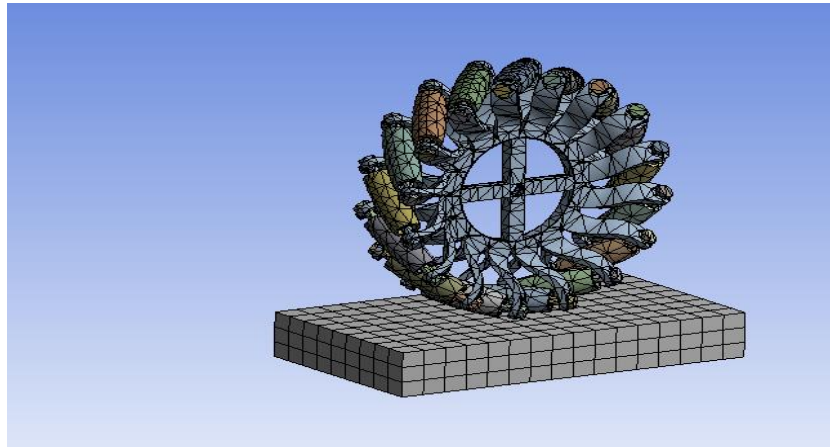

*Figure 4.13: Mesh Generated for Mecanum Wheel*

The same parameters are used for this analysis. The upper plane is fixed on which the wheel rolls. The force is applied at the center of the wheel where it is assumed to be concentrated. For now the static loads are applied to the wheel assuming the wheel to be at rest and touching the surface. The modified design has bends which tend to fail under higher loads. Therefore, for this case 337.21 lbs. load is applied and the feasibility of the wheel structure is checked. The different solutions are described below.

The Figure 4.14 below shows the deformation undergone by the wheel structure:

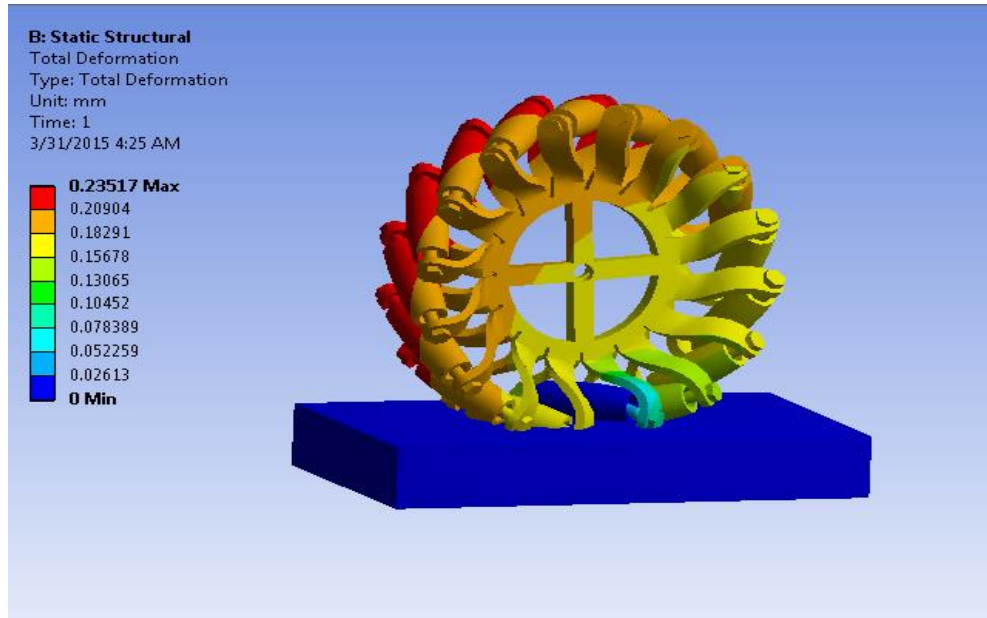

*Figure 4.14: Deformation Undergone by Structure Using Structural Steel*

From the Figure 4.14 above it can clearly be concluded that due to the sharp bends the structure might fail or deform. To protect the structure from getting fail, the sharp edges should be decreased and angle of bending should be changed.

The Figure 4.15 shows the equivalent stress distribution in the wheel structure:

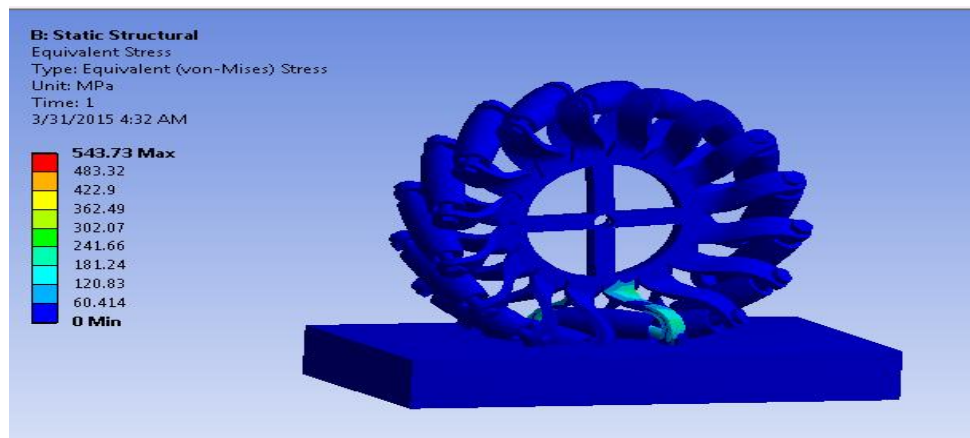

*Figure 4.15: Equivalent Stress Distribution Noticed in Structural Steel Wheel*

The Figure 4.16 shows the safety factor from which it can be concluded that the structure at the bend can fail:

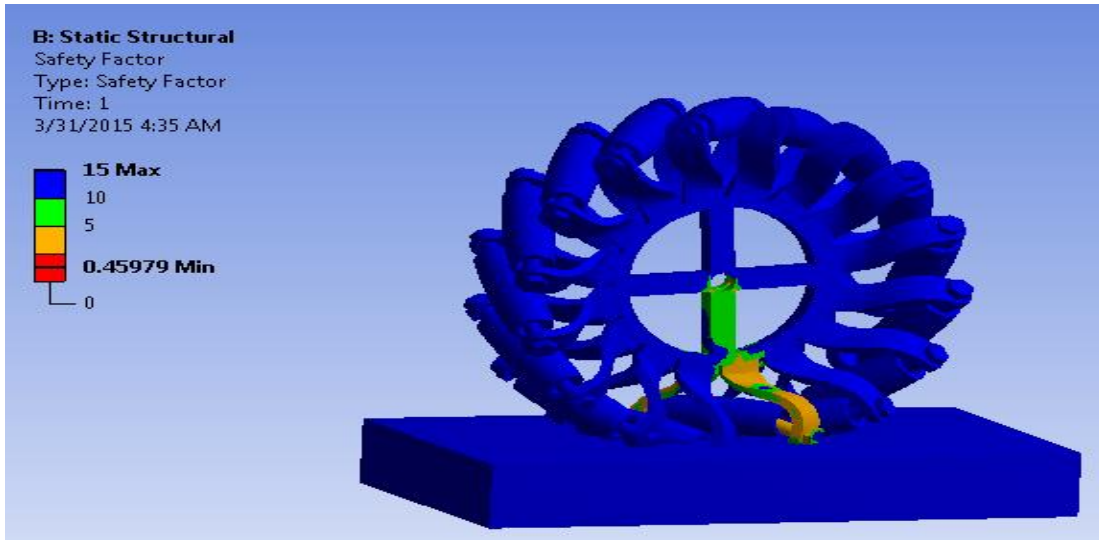

*Figure 4.16: Safety Factor Noticed in Mecanum Wheel Using Structural Steel*

In conclusion, the angle of bends should be decreased to protect the structure from deforming. It is highly recommended and suggested that this is performed in future research.

#### *4.5 Finite Design Analysis for Modified Design Using Aluminum Alloy*

All the parameters used for this analysis remain the same except the material being used. Aluminum is applied to compare results shown below:

The Figure 4.17 shows the total deformation undergone by the structure:

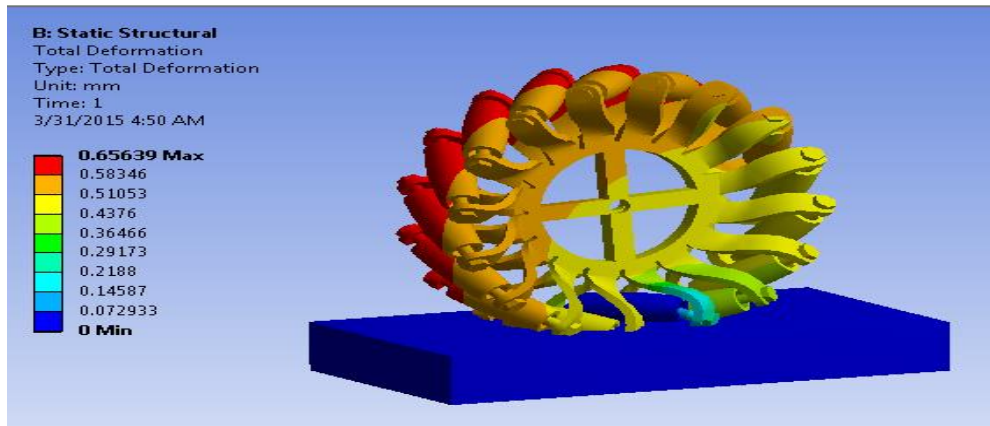

Figure 4.17: Total Deformation Seen when Using Aluminum Alloy

Figure 4.18 shows the equivalent stress which is equally distributed except at the bend of the roller which is connected to the plane:

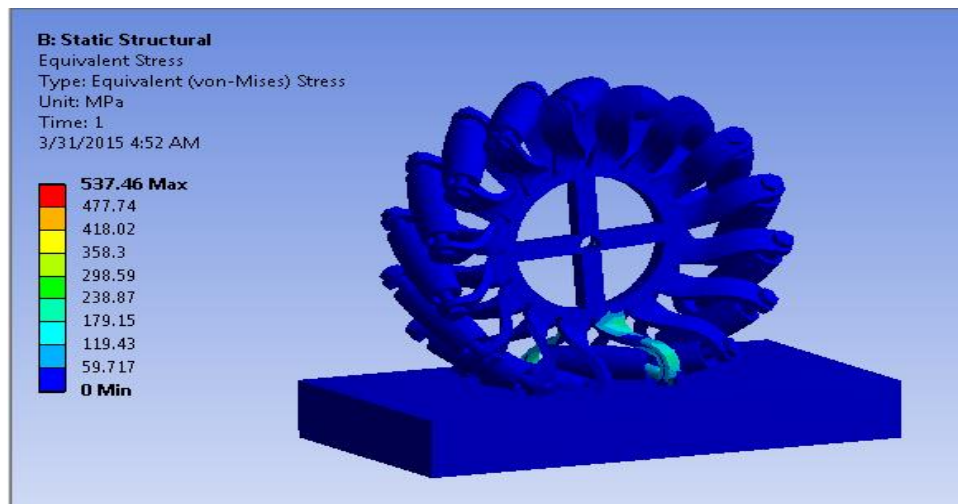
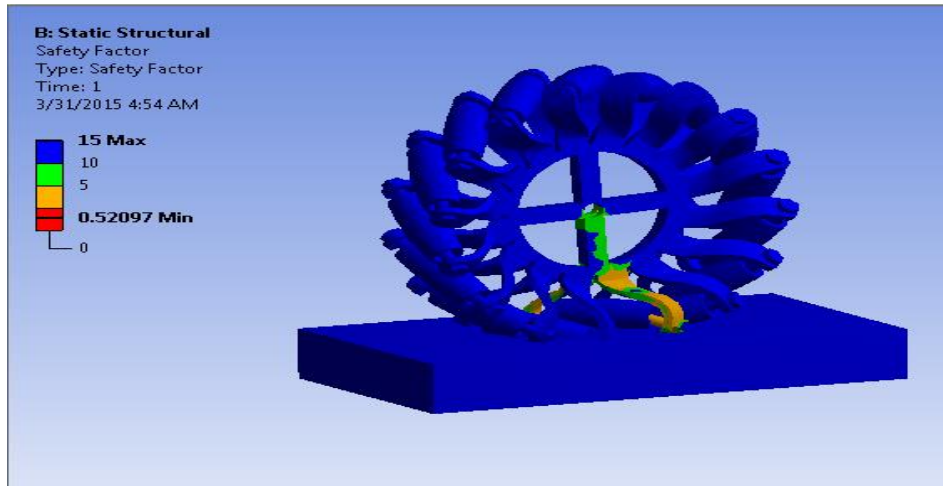

Figure 4.18: Von-Misses Stress Noticed for Aluminum Wheel

The Figure 4.19 shows safety factor as well as possible failure under load application:



*Figure 4.19: Safety Factor Noticed in Aluminum Wheel*

From all the above results it can be concluded that as the further research the bends can be made smoother to protect the structure from failure.



# CHAPTER 5

---

## MANUFACTURING PROCESS AND MATERIAL FOR MECANUM WHEEL

### 5.1 *Manufacturing of Rollers*

Rubber rollers are manufactured through many different methods such as the plying method, extrusion method, press method and cast method etc. Using plying method or calendaring method, a sheet is covered on to the iron core which is not widely used. Extrusion method uses rubber on the iron core using an extrusion machine. Press method uses rubber which is filled into a metal mold and pressed with heat and pressure. Casting method uses liquid resin which is filled into a metal mold and heated in oven.

Specification of rollers manufactured by AndyMark is mentioned below:

- Material used: Gray Rubber
- Weight: 0.351 pounds
- Length: 1.5 in.
- Diameter: 0.750 in.
- 1.25" Outer Diameter ball bearings

It also includes hardware such as roller, rubber with plastic core. Roller is made of Polycarbonate interior and urethane exterior. ¼ inch inner diameter bushing is pressed into each end of the roller. Also, Mecanum Wheel manufactured by Vex Robotics have updated rollers manufactured by them. The difference in their roller is that it includes a co-molded single bushing and a new co-molded Steel tab. Roller is made from rubber and roller mount is made from ABS-PC. SBR black rubber is used to manufacture roller by

Kornylak which provides evidence that different companies use different rubber material for the manufacturing of the roller.

## *5.2 Application of Rubber on the Core*

There are two ways of applying rubber to the roller core which are “calendar” built and “strip” built [17]. Rubber is applied either during the formation of the core or laminating the rubber while core is running through calendar. Following are the ways through which rubber can be applied to the core [18]:

- One of the ways is, in which rubber is attached to the core and then the core is rotated. It is done under the pressure of the carriage of rollers so as to remove air between the layers. The only downfall is that the size of the calendar is limited. As the rubber is applied to the roller it leaves longitudinal line across the face when once the roller is finished. After the calendar rubber is applied, another piece has to be applied which creates another possibility of stripe across the roller.

Different types of rubber have different strength group based on which their reaction depends. The stripe that appears is just the strip of rubber from end-to-end. The calendaring process applies rubber to the core at room temperature which does not help rubber to adhere to the surface when cooled [18].

- The other method is the extrusion method also known as “strip” built which is mostly used for large rollers. The extrusion process prevents entrapped air cells and blisters which creates localized low spots. Rubber is mixed and fed into rubber extruder where screw remixes the rubber and feeds it through a series of

extruder screens that normally makes rubber free from any foreign material. The extruder then releases the rubber which is used to build the roller.

There are many issues noticed which arise because of the way the rubber is applied to the roller core. Therefore, there are many problems noticed with the finish coating. There are many firms which have developed the technique to apply rubber through seamless roll covering. The most of the problem comes from the build lines that exist because of the way the roll is built. Therefore, for high quality coatings silicone is used. To avoid all the problems firms have been using different process called “lapping process”.

### **Lapping Process**

Roller manufacturers should select the rubber type wisely using their experience during extrusion and vulcanization process. Many firms have developed a technique to apply rubber in such a way that it forms monolithic sleeve throughout the entire covering [18].

Lapping process uses the best strip profile, rubber chemistry, vulcanization technique and flow-rate calculation which contributes for rubber to stay at the same position. This is done while applying rubber to the core which eliminates everything that happens to the material before it is cured. Curing process starts once the rubber is mixed. If the end use application is known, defects can be eliminated well before because of which seamless roll covering through lapping process is recommended to eliminate faint lines on the face of the rollers. Also, injection molding, liquid injection molding, compression molding processes can be used for roller manufacturing [18].

### 5.3 Material Used for Manufacturing Roller

There are many different materials used to manufacture rollers. Different firms use different materials for their rollers. Mostly wheels are manufactured using shore 75A-85A polyurethane with a hard ABS plastic core mandrel. Figure 5.1 below shows the shore hardness scale which helps in selecting the right shore for the material used [19].



Figure 5.1: Shore Hardness Scale [19]

However, research is done to use materials which have a broad temperature range and which are more advantageous for the roller manufacturing. For example, AndyMark uses urethane as the exterior of the rubber. Using urethane hasn't proved to be beneficial as peeling of the material has been seen while the roller is in motion. Peeling of the material results into roller being getting damaged which is not desired. To avoid this many materials have been examined for the current study. Figure 5.2 below describes the chart which compares the hardness between different materials with their durometer [20]:

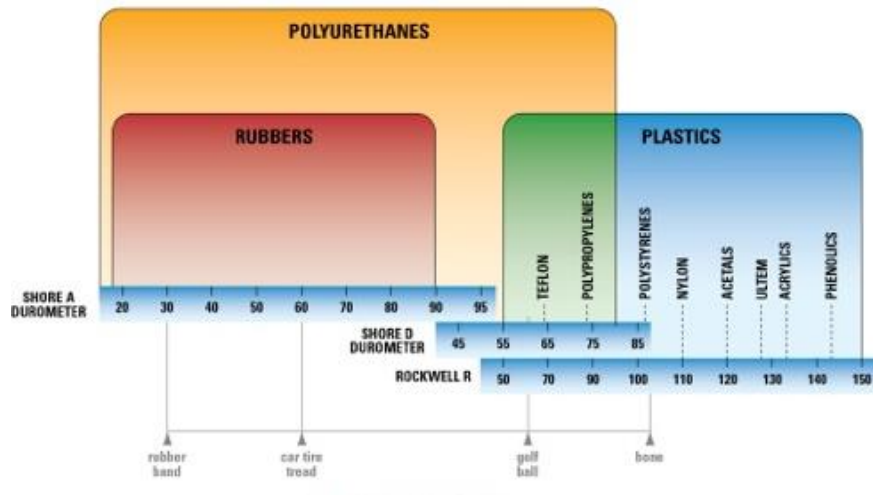

Figure 5.2: Durometer Comparisons of Materials [20]

Different type of rubber materials are mentioned below along with their properties which can be selected for the manufacturing of roller [21]:

**1. SBR (styrene-Butadiene rubber)**

- Lowest cost and highest volume elastomers available.
- SBR is tougher and slightly more resistant to heat and flex cracking.
- Flame resistance is poor.
- It has temperature range of -65 to 225° F.

**2. Polyurethane**

- There are two classes- polyester and polyether.
- It has high tensile strength of 2.8 MPa and is abrasion resistance.
- Polyester is slightly superior to polyether.

- Unlike polyether, polyesters can be affected by hot water and high humidity and also their resistance to acids and alkalis is low.
- Their operating temperature range is -40 to 18° F.

### **3. Ethylene Propylene**

- Low cost, versatile compound that functions well in both low and high operating temperature environments.
- Its temperature range is -65 to 300°F.

### **4. Ethylene Propylene Diene Monomer**

- It is a co-polymer of ethylene and propylene and a smaller amount of diene monomer.
- Its temperature range is -65 to 300° F. Also, chloroprene rubber which is also called neoprene and perfluoroelastomer rubber are used as roller material. All the above rubber materials are been used by different firms to manufacture roller due to their properties and temperature range. Below is the Figure 5.3 that shows different rubber material with their temperature range [22]:

Polymer	ASTM Designation	Durometer (Shore A)	Tensile (psi)	Elongation (psi)	Tear Resistance	Service Temp (°F)	Additional Comments
Ethylene Propylene Diene	EPDM	40-90	2,000	600	Poor - Fair	-60 to 350	Excellent weather resistance
Styrene Butadiene Rubber	SBR	40-90	2,500	600	Fair - Good	-50 to 225	General purpose & low cost
Natural Rubber	NR	30-90	3,500	700	Excellent	-60 to 175	Excellent properties
Butyl	IIR	40-80	2,500	850	Good	-60 to 225	Excellent gas impermeability
Nitrile (Buna® N)	NBR	40-90	3,000	600	Fair - Good	-40 to 250	Excellent oil & compression set resistance
Hydrogenated Nitrile	HNBR	45-90	3,500	600	Fair - Good	-40 to 300+	Better temperature performance than NBR's
Polychloroprene (Neoprene®)	CR	40-90	2,500	600	Good	-50 to 250	Excellent oil/gas resistance
Fluoroelastomers (Viton®, Aflas®)	FKM	55-90	2,500	400	Good	-20 to 400+	Excellent heat & swell resistance
Silicone	MQ	40-80	1,500	600	Poor	-150 to 600	Excellent temperature resistance
Urethane	AU / EU	60-95	7,000	700	Excellent	-30 to 175	Excellent wear and strength
Epichlorohydrin	ECO	40-80	2,000	350	Fair - Good	-50 to 225	Good oil resistance

Figure 5.3: Comparison between Different Materials Depending on their Temperature [22]

It can be concluded from the above Figure 5.3, that the best material to use for manufacturing of rollers are either Viton Rubber or Silicone. Below, are the details which best describes the advantages of using Viton Rubber and Silicone as the roller manufacturing material.

**Viton Rubber of Shore 75A:** Viton rubber is the trade name for fluorocarbon elastomers. They have many advantages such as [23]:

- Excellent resistance to high temperature and low compression.
- Resistance to ozone, oxygen, mineral oil, synthetic hydraulic fluids, fuels, aromatics and many organic solvents and chemicals.
- It corresponds very well over a temperature range from -40° to +400° F. It is limited to low temperature resistance which is -40° F approximately. Gas permeability is very low and it is similar to that of butyl rubber.

- It is of durometer, shore A 75±. Its minimum tensile strength is 1446.02 Psi and also, its minimum elongation is 150%.

**Silicone of Shore 70:** This compound offers a wide temperature range which is from -80° F to +400° F and has excellent dry heat resistance. Some of its advantages are [23]:

- Silicone is the best flexible for low temperature of all elastomers and it can be used down to -150° F. It also has good resistance.
- It has good resistance to ozone and weather and is also a very good insulator.

The only downfall is that, the material is not recommended for dynamic condition due to its low tensile and tear strength. It is of Durometer 70± shore. The minimum tensile strength is 870.22 Psi. Its minimum elongation allowance is 150%. Looking at their properties it is preferred to use Viton rubber of shore of 75 A and Silicone of shore 70 A as the manufacturing material for the roller.

#### **5.4 Rubber Rollers**

Rubber rollers are actually cylindrical tubes that consist of natural or synthetic rubber or rubber bonded to a core. These rollers are fabricated using variety of elastomeric materials such as silicone, EPDM, nitrile, polyurethane, neoprene, etc.

Rubber rollers are manufactured with metal cores. Roller cores can be manufactured from material such as Aluminum, Steel, and Stainless Steel. There are many different type of rollers manufactured such as guide rollers, ink rollers, grooved rollers, laminating rollers, dead shaft rollers, etc. Dead shaft rollers have internal bearings at the location of the spinning roller that rotates around a stationary shaft [24].



Rubber rollers are typically manufactured using molding or casting processes, but they can also be manufactured by using extrusion process. Injection or compression molding is used for solid rubber rollers. In injection molding, the elastomeric material is heated and then injected into the cavity of a split die chamber or mold, which is then clamped, shut and eventually cooled to form the part. Figure 5.4 below shows gray rubber roller manufactured by AndyMark [25]:



*Figure 5.4: Gray Rubber Roller [25]*

Different firms use different rubber material for the manufacturing of the roller according to their necessity.

### ***5.5 Core Manufacturing Material and Manufacturing Process***

Before, urethane inner core and a soft urethane outer core were used. Casting method was used to cast the frame of the wheel [26]. Lately, inner core of the rollers were made through molded plastic. For example, AndyMark uses polycarbonate core. Also, the main idea of Helical Robotics is to use knurled Aluminum core to handle the temperatures which a polycarbonate core cannot. For low and prototype production runs, the current industry standard is to make roller contours from a rod of Aluminum.

Aluminum rod is manufactured using CNC machine. Aluminum rod is CNC milled and CNC turned to fabricate the details of the core. The CNC lathe can also be used to knurl or thread the core as well. There are many lathes available which offers a cut-off feature, where a single rod can be inserted and it produces dozen of cores at once. If both ends of the roller have a pocket feature, the first can be made on the piece of rod stock and the second would need to be done after the roller is cut off in another turning operation. Grinding and polishing process are done to achieve roller surface finish [26].

Also, the Aluminum core can be manufactured using casting method. Mostly through casting process cores are made out of sand, but they can also be made out of metal. Investment casting method can be used for the formation of the core. In investment casting a cored hole can be made by the ceramic shell mold, which is then knocked out after solidification. Casting process can be used to achieve mass production of core but the quality is not of good grade and also it cannot hold high tolerances. It is, therefore beneficial to use CNC lathe machine to manufacture Aluminum core because lathe can cut off parts when they are finished. One piece of stock can make dozens of parts without human intervention unless and until the second turning operation for the cut off end is required [26].

Rollers are also made out of composite material. They are made with the use of filament winding process. The technology used by the firm in filament winding process produce laminate that are accurate, efficient and repeatable. Using computer-controlled processes low void laminates are produced that has outstanding performance and fatigue properties. If resin content, bandwidth, fiber placement and lamina thickness are kept

under control then the highest quality product can be received [27]. Advantages of composite rollers are mentioned below [27]:

- Lower mass, lower torque, lower inertia, and lower tension and wrap angle.
- Increase in corrosion resistance and reduced weight improves the process, reliability and product consistency.
- Composites are much lighter than metal rolls and it results into low rotational inertia which increases the production speeds.
- Composites are also stiffer and more stable which reduces damage and failures.

### ***5.6 Roller Bearing***

Roller bearings are rolling element which uses rollers as object to maintain separation between the moving parts of the bearing. The main purpose of roller bearing is to reduce the rotational friction and also to support radial and axial loads. When compared to ball bearings, roller bearings can support heavy radial loads and limited axial loads. They also have wide range of speed at which they can operate. There are many different types of bearings some of which are: ball bearings, roller bearings, and roller thrust bearings, ball thrust bearings, tapered roller bearings, etc. [28]

### ***5.7 Manufacturing of Wheel Plate***

Wheel plate can be manufactured using many different methods. Most wheels have been manufactured using Aluminum/Steel stamped plates alone; spot welded Steel stamped plates, riveted Steel plates, plastic or nylon core between the plates for structural reinforcement. The main idea is to manufacture the wheel as a one part using stamping

method, which is one of the most prominent methods that can be used. Also, different methods will be evaluated in the following section.

### **Stamping Method:**

This technique utilizes level sheet metal which is either in clear or loop structure. This sheet metal is put into a stamping press where an instrument passes on surface structures of the metal into a foreordained shape. Other manufacturing process such as punching, banking, embossing, bending, flanging and coining can also be done on sheet metal using stamping [29].

Stamping is also a single stage operation in which the desired form of sheet metal part is formed by every stroke of the press or could be done through a series of stages. Stamping is usually done on cold metal sheet. It has also replaced die forging and machining. Also, progressive stamping can be used for metal working method that includes punching, coining, bending and other modifying process combined with an automatic feeding system. Each station performs one or more operations until the part is made [30].

Rotary plate stamper is one of the equipment that is used to stamp the parts instead of using the stamping press. The surface speed of the stamping wheel is synchronized with the speed of the plate using a friction drive between the plate and the drive wheels. This wheel is actuated by a PLC signal, which is also in constant contact with the plate. The marking wheel rises automatically when once the entire plate has been stamped. A manual stamping mode can be used for additional marks on long plates [31].

### **Benefits of the Stamping Process [32]:**

- **Cost efficiency:** The biggest advantage of stamping over cutting is the cost efficiency. Stamping takes less processing time than the cut processing and the cost is reduced. Die manufacturing is not required when using stamping process and thereby cutting manufacturing cost.
- **Consistent Quality:** Stamping utilizes large amount of material which is processed all at one time compared to the cut processing in which material is cut one by one. Hence, stamped parts are more consistent than parts made by cutting method.
- **Processing of Complex Shapes with Precision:** Complex geometry can be manufactured using stamping process which is more precise than cutting process.
- Stamping process produces less scrap material.
- The set up time is much less than any other process.
- It creates the complete geometry of the desired product with a single process.

### **Spot Welded Steel Stamped Plates**

Spot welding can be done on sheet metal parts which also allows adding various hardware such as nuts, bolts or hinges to the part. This is an accurate, economical and efficient method of assembly. Spot welding uses heat obtained from resistance to electric current to join metal surfaces. Different welding methods are used to connect two parts. Spot welding is mainly used when welding sheet metal, welded wire mesh or wire mesh [33].

Aluminum alloys can be spot welded but the only downfall is that it produces much higher thermal conductivity and electrical conductivity hence requires higher

welding currents. It is one of the most common applications in automobile manufacturing industry [33].

### **Riveted Steel Plates:**

Cold rivet is used to join plates permanently together. The material of the rivet normally matches the material to be riveted together. Steel rivets are used for joining Steel plates and Aluminum rivets are used to join Aluminum plates. The plates are placed over the rivet and are pushed in order to see that there are no gaps between them. AndyMark uses the plate which has interior body made up of stamped Aluminum while the perimeter side plate is made of thick Steel. The perimeter plate is riveted to the interior body and each perimeter bent tab rests on the interior body rim. This support allows handling more load material used for wheel parts [34]. Hence, it is also recommended to use perimeter plate as a support for the Mecanum Wheel.

After evaluating all these manufacturing process, it can be concluded that stamping process is the most economical method to manufacture wheel plate. Wheel plate can be produced in mass using stamping which forms the plate all at one time. The process is also cost efficient. Less material is used and the part can be manufactured with less scrap being produced.

### **Material Used to Manufacture Wheel Plate**

Steel and Aluminum are two most economical material that can be used to manufacture the wheel plate. Looking from the designer's point of view both the materials are compatible but there are always some pros and cons related to the material. Comparisons between both Steel and Aluminum are described below [35].

**Based on Cost:**

Cost of Aluminum and Steel always changes based on global supply demand, fuel costs and price and availability of iron and bauxite ore. Steel is cheaper than Aluminum when comparing per pound. The price of finished product also depends on the amount of the material used. But, if two identical parts are made (one with Aluminum and one with Steel) then the part made from Aluminum is more costly than Steel [35].

**Strength and Malleability:**

Aluminum is more malleable and elastic than Steel. Also, Aluminum can create shapes that Steel cannot. It also forms deeper and intricate shapes. Steel is very tough material but it cannot be pushed to same extent at which Aluminum can be pushed. This can be done without cracking or ripping during the manufacturing process [35].

**Corrosion Resistance:**

The most important feature of Aluminum is that it is corrosion resistant without any further treatment after it is spun. Aluminum does not rust and also, it does not need any further treatment like paint or coating to protect it from wear. On the other hand Steel has to be treated or painted after manufacturing part which would protect it from rust and corrosion [35].

**Weight Difference:**

Steel is harder when compared to Aluminum. But, alloys of Aluminum get tempered or scratch more easily. Steel is strong and also will not warp, deform or bend underweight, force or heat. Steel is much heavier than the Aluminum and it is 2.5 times

denser than Aluminum. Aluminum has low density and is prone to vibrations. One of the most widely used high strength Aluminum alloy is alloy 6061 with T6 temper. Alloy 6061-T6 I is stronger than some Steel alloys.

Comparison between both Steel and Aluminum comes to conclusion that either of the material can be used to manufacture the wheel plate. Both have their own advantages and disadvantages. It now depends on the manufacturer and designer to decide on which material to be used depending on type of plate they need. Mostly, Aluminum is used to manufacture wheel plate because of its maximum advantage over Steel. Also, it depends on the load carrying capacity and size of the structure so as to decide which material to be used.

#### **5.8 *Traction in Mecanum Wheel***

It has been proved that a Mecanum Wheel has less traction than an ordinary standard wheel. To prove, the theory has been described below. Figure 5.5 below shows the bottom view of the front port-side of the Mecanum Wheel roller which is in contact with the floor [36]:



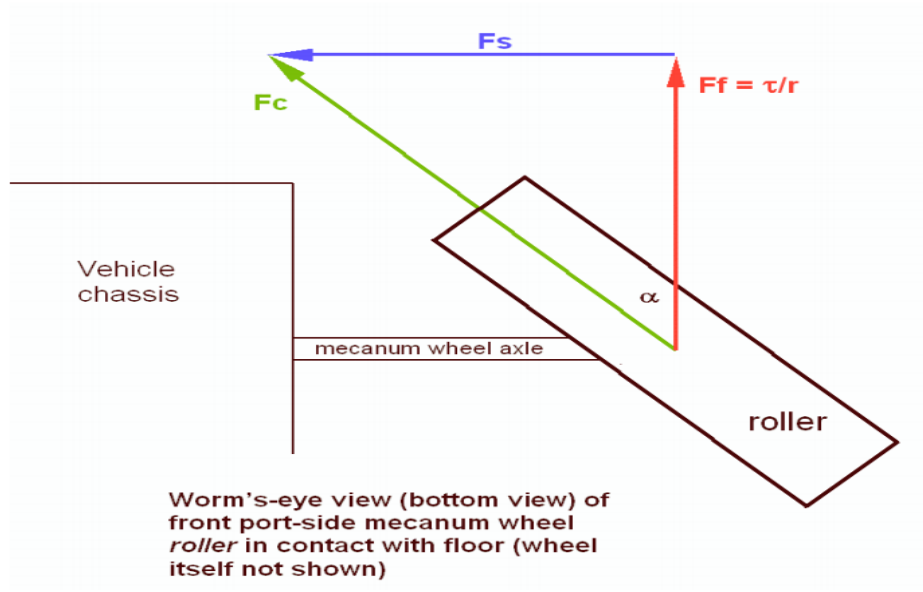

Figure 5.5: Bottom View of Mecanum Wheel Roller [36]

$F_c$  = Reaction force produced by the floor on the bottom of the Mecanum Wheel roller which is in contact with the floor. This force should also be aligned along the roller axis, assuming that roller bearings do not produce friction [36].

$F_c$  also has two components as shown in Figure 5.5, which are  $F_s$  and  $F_f$ . Where,  $F_s$  is the force which is counterbalanced by an equal but opposite force from the wheel on the other side of the vehicle when that wheel is being driven with the same torque.  $F_f$  is the forward component which is in the plane of the Mecanum Wheel. When wheel is not in motion component  $F_f$  should be equal to  $\tau/r$ .  $\tau$  is the driving torque applied to the Mecanum Wheel and  $r$  is the radius of the Mecanum Wheel. Forward force produced by the Mecanum Wheel is same as the force produced by an ordinary wheel which has the same diameter and driven with the same torque. The only difference is that the force of the floor acting on the roller is greater than an ordinary wheel by factor  $1/\cos\alpha$ . This

reaction force is high which breaks the friction and slip associated with Mecanum Wheel with the floor [36].

Considering the case where the vehicle is moving forward, the rear port side of the wheel is driven with the same magnitude as the front wheel but in backwards direction.  $F_f$  wheel is counterbalanced by equal and opposite force which is due to the back wheel of the vehicle.  $F_s$  remains in the same direction for both front and rear wheels. Considering no bearing friction the pushing force of the vehicle remains same for both fore and sideways direction [36].

The Figure 5.6 below describes the vectors in dotted lines which are for reference [36]:

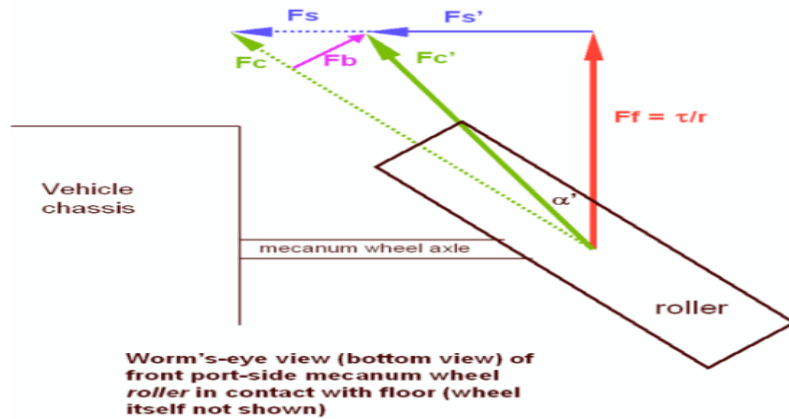

Figure 5.6: Change in Vector Components due to Forward Motion [36]

When the wheel moves forward, the forward force vector remains unchanged. As seen in Figure 5.6 new vector  $f_b$  reduces the angle and magnitude of the vector  $F_c$  which is now  $F_c'$ . Reduction of magnitude  $F_c'$  shows that the greater forward force can be applied by increasing the driving torque before the roller breaks friction with ground.

This is the reason why Mecanum Wheel can have more traction and that is why roller bearings are used which improves the traction of the Mecanum Wheel [36].

As shown in Figure 5.6  $F_s$  magnitude is also reduced to  $F_s'$  which is due to the introduction of the roller bearing friction  $F_b$ . Also, for the friction free case the sideways pushing force has been reduced. To obtain this, the motor torque should be increased to obtain the same sideways driving force. Increase in sideway force by increasing the motor force also gradually increases the reaction force  $F_c''$  which is shown in Figure 5.7 below. Hence the roller bearing friction is the main reason behind the reduction of friction and available force in sideways direction [36].

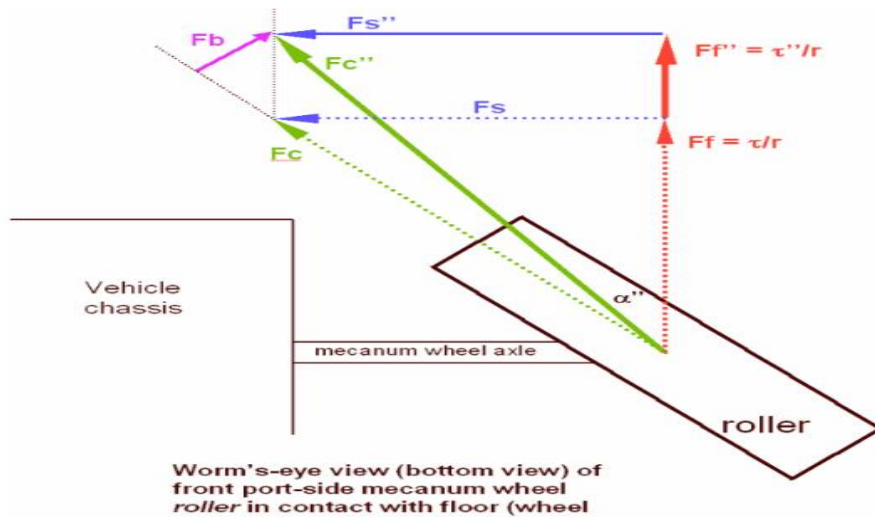

Figure 5.7: Increase Noticed in Motor Torque [36]

The above case shows that Mecanum Wheel has low traction and it is due to the roller bearing. Also, it has been proven that more weight on the tire generates more traction.

## 5.9 *Roller Bumpiness*

Bumpiness seen in the Mecanum Wheel rollers decreases the efficiency of the wheel. If the number of rollers are not chosen properly it gives rise to bumpiness which is seen between rollers. The increase in number of rollers decreases the vibrations. Therefore, selecting the number of rollers for certain size of the Mecanum Wheel becomes an important factor. When the wheel spins, same velocity exists on different parts of the wheel and there may also be possibility of minor bump which occurs due to the rolling of a wheel in forward direction [37].

Strafing is also one of the factors which can arise if proper angle is not been set between rollers. However, for Mecanum Wheel it is not an issue because of angles is kept at  $45^\circ$ . The rollers should be arranged in such a way that they are completely packed but also, care should be taken that they do not overlap which would cause bumps. One of the problems with Mecanum Wheel is that the wheel tends to touch the surface while moving on an inclined surface which prevents the wheel from operating efficiently. To correct this problem, the rollers which are split into two bodies are used [37].

If there remains gap between rollers it leads to discontinuous contact with the ground and further leads to vibrations. Mecanum Wheel has been designed in such a way that there is constant contact between rollers and surface. Also, paper has been reviewed to find bump free rollers. The main idea behind it is to find radius which helps the rollers not to overlap and make it bump free. If radius assumed is not correct it would tend to overlapping of rollers which is not desired. This is the reason because of which at most care should be taken while designing the roller profile on which wheel efficiency

depends. Figure 5.8 below describes the profile of the roller which is mounted on a Mecanum Wheel [37]:

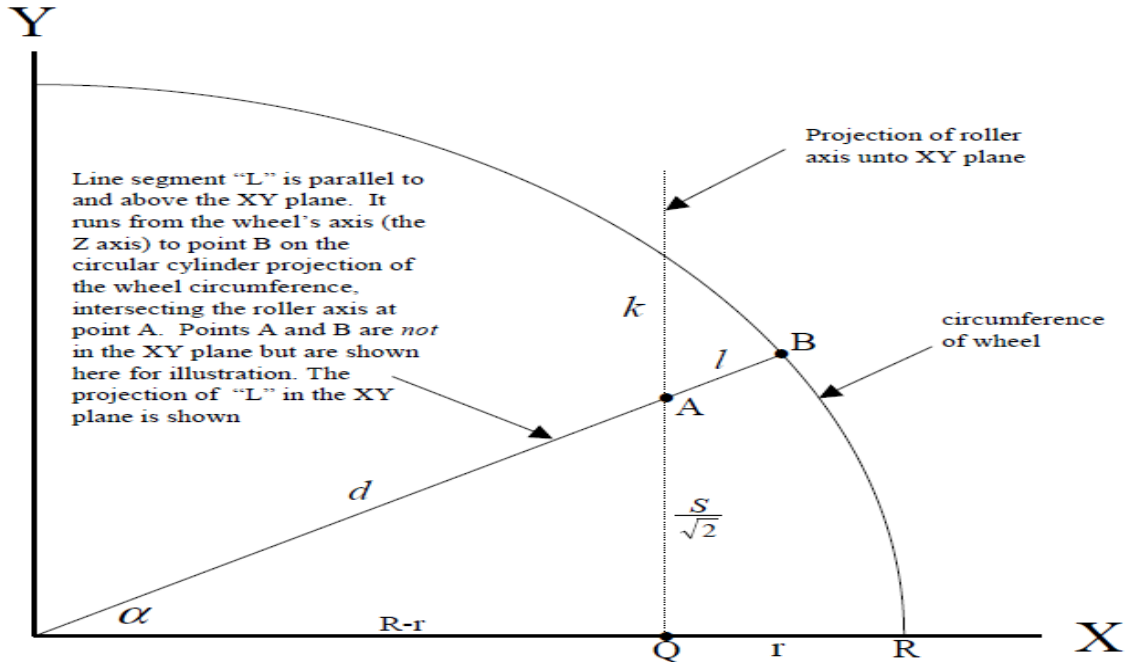

Figure 5.8: Roller Profile [37]

Where,

$R$  = Wheel radius

$R$  = Roller maximum radius

$S$  = Distance which is measured along the roller axis to intersection with line “L”

$\theta$  = Angle between line “L” and the roller axis (this angle is not in the XY plane).  $\theta$  is the angle between two vectors.

Also, the rollers are placed at 45° angle. Wheel is assumed to be lying in the XY plane. A value of R and r are selected based on the Mecanum Wheel designed. Values of S are varied from zero to half the length of the roller axis to calculate different values for other parameters. Some of the derived formulas are mentioned below [37]:

$$\alpha = \tan^{-1} \frac{S/\sqrt{2}}{(R-r)}$$

$$d = \frac{R-r}{\cos \alpha}$$

$$l = R - d$$

$$\theta = \cos^{-1} \left( \frac{\sin(\alpha)}{\sqrt{2}} \right)$$

$$h = S + \frac{l \sin(\alpha)}{\sqrt{2}}$$

$$R_r = l \sin \theta$$

The above mentioned equations are parametric equations where S is the parameter. Where, R<sub>r</sub> is the roller radius at distance h from the center of the roller. This parametric equations derived, can be made simpler by converting it to basic equations which does not contain any trigonometric functions. Algorithm procedure which has been used from the paper revised to obtain roller profile equations is mentioned below [37]:

Starting with calculating the diameter, D=R-r.

Where, R = Radius of the Mecanum Wheel and r = Radius of the roller measured at the midpoint of its axis. The length of the roller is mentioned from the roller designed in CAD. Different values of S are assumed from zero to half the length of the roller axis.

$$F = \sqrt{(2 * D^2 + S^2)}$$

$$G = \sqrt{4 * D^2 + S^2}$$

$$T = \frac{\sqrt{2} * R}{F}$$

$$h = \frac{S}{2} * (T + 1)$$

$$R_r = \frac{G}{2} * (T - 1)$$

From all the above equations the radius of the roller which will best suit to avoid bumps can be found and will be at the distance h from the center of the roller. Hand calculations are performed to support the above mentioned equations which would be helpful to roughly estimate the roller radius. Based on the roller designed for this thesis, the wheel radius is 3 in. and the roller radius measured at the midpoint is 0.516 in.

Calculating,  $D = R - r$

Where,  $R = 3$  in.;  $r = 0.51$  in.

The value of the parameter D is found to be 2.484 in.

Calculating F using equation,  $F = \sqrt{(2 * D^2 + S^2)}$  and substituting all the above mentioned values; the value of  $F = 3.70$  in. Similarly calculating G using equation,  $G = \sqrt{4 * D^2 + S^2}$  and substituting all the values; the value of  $G = 5.10$  in. Also, the equations are calculated using the value of S equals to 1.17 in. which is half the length of the roller.

Calculation of T using the equation,  $T = \frac{\sqrt{2} \cdot R}{F}$  and substituting the values obtained from the parameters calculated it gives  $T = 1.14$  in. Similarly calculating h, using the equation  $h = \frac{S}{2} \cdot (T + 1)$  the value obtained for  $h = 1.24$  in.

Finally radius of the roller is checked to confirm that the assumed roller radius in CAD is appropriate. Roller radius is given by the equation,  $R_r = \frac{G}{2} \cdot (T - 1)$  and when calculated the value obtained is 0.357 in.

Looking at the value of the roller radius 0.357 in. it can be seen that it is less than the roller radius which is 0.516 in. used in CAD and which is also measured from the center of the axis. Practically, the obtained value looks correct as the roller radius decreases when going away from the center of the roller because the parabolic curvature has the fattest portion and the larger radius is seen there. Also, affinity feature has been used to decrease the size of the rollers by 33% which also accounts for the difference in radius. Hence, the above equations prove that the selected radius of the roller will perform well and won't result into the generation of the bumps because of the perfect radius chosen.

Sometimes user defined profile isn't available in CAD because of which the simple formula for the profile has been generated. This formula would be helpful to obtain the radius of the roller with not much accuracy but the value will be very close. Below are the equations with which the roller radius is calculated. Here L equals to 2.34 in. which is the total length of the roller. As mentioned above the values of  $R = 3$  in. and  $r = 0.516$  in.



Calculating diameter using equation,  $D = R - r$ ; the value of D obtained is 2.484 in. Calculating F using equation,  $F = \sqrt{(2 \cdot D^2 + (L/4)^2)}$  and substituting all the required values, the value obtained for F is 3.56 in.

Now, calculating G using the equation,  $G = \sqrt{(4 \cdot D^2 + (L/4)^2)}$  and substituting the required values, the value obtained for G is 5 in. Then calculating T for which the equation,  $T = R \cdot \sqrt{(2)/F}$  is used. The value obtained after substituting the other parameters is 1.19 in.

Now, calculating parameter a using the equation,  $a = 32 \cdot (2 \cdot r - G \cdot (T - 1)) / (L^2 \cdot (T + 1)^2)$  and the value obtained is -2.077 in.

The formula for the profile is given by,  $y = r - ax^2$  and when on substituting the value of y equals to 3.35 in. Using this parametric equation, the radius of the roller comes out to be 3.35 in. which is not exact but which is a nearby value when compared with the original profile which are 8.5 in. Also, it is calculated from the midpoint of the roller. These above mentioned equations are very useful to calculate the feasible radius of the roller so as to avoid the bumps in wheel which is not desired for its efficient working.

### *5.10 Calculation of Kinematic Velocity and Force for Both Omni-directional and Mecanum Wheel*

Also, it has been proved that the Mecanum Wheel generates 41% more driving force than the Omni wheel. Also, Omni wheel goes 41% faster than the Mecanum Wheel assuming the same wheel speed. The theory behind it makes sense because the roller of the Mecanum Wheel being at 45 degrees pushes the wheel forward which is higher than

the force that would drive the Omni wheel. Calculations are performed to support the above theory [37].

Assuming that wheel moves 2 rev/sec, the wheel speed results to 12.57 rad/sec. Hence,  $\omega$  (wheel speed) = 12.57 rad/sec. Also, torque is calculated which equals to the product of force applied and the perpendicular distance of force from the axis of rotation. Assuming that 200.07 lbs. force is applied to the wheel and the distance covered is 3 in., the torque calculated is:

$$\begin{aligned}\tau &= F \cdot d \\ &= 47.26 \text{ lb-ft}\end{aligned}$$

**Nomenclature:**

$V_F$  = Forward Velocity

$V_r$  = Strafe velocity

$V_D$  = Diagonal velocity

$F_f$  = Forward Force

$F_r$  = Strafe Force

$F_D$  = Diagonal Force

**Calculating Kinematic Velocity for Omni-directional Wheel:**

By calculating forward velocity which is given by equation,  $V_F = \omega \cdot r \cdot \sqrt{2}$  the value obtained is equal to 53.30 rad in/sec. On calculating strafe velocity whose equation is given by  $V_r = \omega \cdot r \cdot \sqrt{2}$ , the value obtained for it is equal to 53.30 rad-in/sec. on

calculating diagonal velocity using equation  $V_D = \omega * r$ , the value obtained is equal to 37.67 rad-in.

### **Calculating Force for Omni-directional Wheel:**

The equations for forward force, strafe force and diagonal force are described below:

$$F_f = (4 * \tau) / (r * \sqrt{2})$$

$$F_r = 4 \tau / (r * \sqrt{2})$$

$$F_D = (2 * \tau) / r$$

On calculating the above equations by substituting the required parameters; the value of forward force comes out to be 535.03 lbs., for strafe force value comes out to be 535.03 lbs. and the value obtained for diagonal force is 378.10 lbs.

### **Calculating Velocity for Mecanum Wheel:**

For calculating forward velocity, strafe velocity and diagonal velocity the equations are described below:

$$V_F = \omega * r$$

$$V_r = \omega * r$$

$$V_D = (\omega * r) / \sqrt{2}$$

The value obtained for forward velocity comes out to be 37.67 rad-in., for strafe velocity is 37.67 rad-in., for diagonal velocity the value comes out to be 26.61 rad-in.

### **Calculating Force for Mecanum Wheel:**

When calculating force for Mecanum Wheel, the forward, strafe and diagonal velocity can be obtained using the following equations:

$$F_f = (4 * \tau) / r$$

$$F_r = 4 \tau / r$$

$$F_D = (2 * \tau * \sqrt{2}) / r$$

The values obtained after substituting the above values, the forward force calculated is 756.20 lbs., and the strafe force calculated is 756.20 lbs. And, the diagonal force calculated is 534.71 lbs.

Comparing the forward force for the same wheel speed the Omni-directional wheel offers more speed than the Mecanum Wheel. Here, when compared forward force by Omni-directional wheel is greater than the Mecanum Wheel i.e. forward velocity 53.30 rad-in. offered by Omni-directional wheel is greater than 37.67 rad-in. offered by Mecanum Wheel. Also, for the same wheel torque the forward force of the Mecanum Wheel is greater than the Omni-directional wheel i.e. 756.20 lbs. force applied by Mecanum Wheel is greater than the 535.03 lbs. force applied by Omni-directional wheel.

# CHAPTER 6

---

## CONCLUSION AND FURTHER RESEARCH

### *6.1 Results Accomplished*

The main aim of this thesis was to re-design the Mecanum Wheel as desired by the company Helical Robotics. The idea behind designing the wheel structure was to have a design which is different from the design proposed by AndyMark, which is known for their Mecanum Wheels. Along with coming up with different designs, it was also important to have the most optimum and feasible design while reducing the current flaws. Some of the problems along with their solutions are described below:

1. The main problem with the AndyMark wheel is that, bumpiness is sometimes noticed while the wheel is in motion.

To overcome with this problem it is very necessary to set the roller radius in such a way that it does not experience bumpiness. If the rollers overlap they cause problems and even gap between them causes discontinuous motion which results into bumpiness of the wheel. For this thesis as per the new design the radius of roller is assumed as 0.516 in. which is different than the radius of curvature used by the company AndyMark. This was assumed purely based on trial and error process. Also, when verified with a proposed theory it came out to be a nearby value which was found to be 0.357 in. This difference was practically true as the radius decreases when going away from the center of the roller. Using this radius the rollers are designed, and can be seen that the rollers does not overlap which is the biggest advantage. The above problem was solved by coming up with a feasible radius for the rollers.

2. The second problem which was to be solved was the material used by both rollers and the wheel plate.

To overcome this problem, different materials for both rollers and wheel plate are discussed in previous sections. For the wheel plate it is beneficial to use Steel or Aluminum. Both the material have some pros and cons. The material selection then depends on the manufacturer based on the usage. Also, it depends on other parameters such as the force that the structure needs to withstand. Steel is denser than Aluminum but the great advantage is that it can withstand more load than Aluminum. On the other side Aluminum weighs lighter than Steel which is its great advantage. Using Aluminum, there are two benefits the object will be lightweight also which leads to less material usage and less the cost. Aluminum is cheaper than the Steel, which can prove to be beneficial for bulk manufacturing. Aluminum of kind 6061-T6 I is stronger than many other Steel alloys. There are many different Aluminum alloys available which are stronger than Steel and the factor strength is taken care of even while using Aluminum material. The further conclusion is that either of the material can be used based on the usage but Aluminum should really be taken into consideration because of its various properties.

The other most important section is the material used for rollers. Problem has been detected while using the rollers manufactured by the AndyMark because of the material getting ripped while the rollers in motion. The material used for rollers is not of great quality which can withstand high loads. Therefore, it became necessary to come up with alternate of the material used by AndyMark which is gray rubber. Based on the Durometer and hardness scale mentioned in chapter 5, two of the materials that are suggested to use are Viton rubber and Silicone. After comparing different materials that

could probably be used for the roller material, the properties of both Viton rubber of shore 75 A and silicone of shore 70 were found to be most appropriate to be used.

Advantages of these materials are their hardness and ability to perform under high temperatures. Usage of these materials should be done to avoid the material ripping off which leads to the failure of the roller. Failure of even one roller is not desired for the smooth functioning of the wheel. Ripping of material could cause discontinuous motion of the wheel structure which is not desired.

3. Also, one of the factors that was to be taken care of was the weight of the wheel structure. The wheel structure was designed in such a way that the weight reduction is seen which has proven to be the biggest advantage. The weight of the wheel has been reduced from 1.9 lbs. to 1.04 lbs. Also, when checking the feasibility of the wheel structure it was found to be safe which means that all the chosen parameters worked fine.
4. The basic idea of re-designing the wheel structure was to come up with such a design which could be manufactured in one step. The proposed new design has proved to be beneficial as it can be manufactured using stamping process which could save ample amount of time and saves manufacturing costs too.

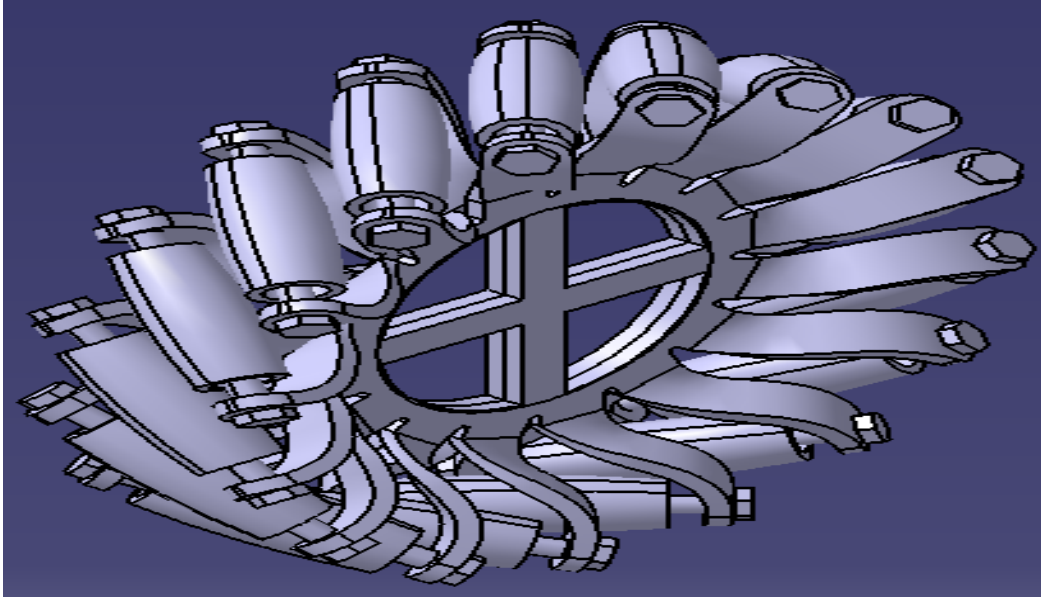

*Figure 6.1: Final Design of the Mecanum Wheel*

The project is successfully completed by proposing a new design of the wheel as shown in Figure 6.1. It is highly recommended to manufacture the above designed Mecanum Wheel due to its various advantages and also it is different from the patented design

## **6.2 Further Studies / Research**

For this thesis the Mecanum Wheel was designed using GSD workbench. Due to the time constraint it could not be designed using sheet metal design workbench, which proves to best while dealing with bends. Usage of sheet metal design workbench is recommended for the further studies to reduce the current design flaws and make it more optimum. Also, analysis can be done on it to check its feasibility as done for the currently designed Mecanum Wheel. Further the Mecanum Wheel can be manufactured using actual metal material to check for its load carrying capacity and to have a physical model.



The wheel can be attached to chassis and a complete robot can be manufactured so as to look at all the constraints. A detailed cost analysis should also be carried based on the manufacturing and tool costs. Further research is recommended to design and manufacture the hub through which the wheel will be attached to the chassis. The assumptions done for this thesis can be put into work by getting the model manufactured. The different factors like roller bumpiness, traction, etc. can be measured once the robot has been manufactured.

Also, the current FEA analysis is based on static loading, it is advised to analyze the Mecanum Wheel using explicit dynamics for both Steel and Aluminum material. Hence, the mentioned recommendations should be taken into consideration and further analysis should be carried out.

# REFERENCES

---

1. Rojas, Raul. N.P., 2015. Web. 3 Mar. 2015.
2. FerroTanker-5. (n.d.). Retrieved March 7, 2015, from <http://www.helicalrobotics.com/FerroTanker-5>
3. AndyMark.com, 'Mecanum Wheels - AndyMark'. N.P., 2015. Web. 8 Mar. 2015.
4. n.d. Retrieved April 3, 2015, from <http://ftp.inf.fu-berlin.de/pub/Rojas/omniwheel/Diegel-Badve-Bright-Potgieter-Tlale.pdf>
5. Helicalrobotics.com, 'Helical Robotics'. N.P., 2015. Web. 7 Mar. 2015.
6. Khurmi, R. S, and J. K Gupta. *A Textbook of Machine Design*. New Delhi: Eurasia Publishing House, 2005. Print.
7. Mitchell, Brian S. *An Introduction to Materials Engineering and Science for Chemical and Materials Engineers*. Hoboken, NJ: John Wiley, 2004. Print.
8. Khandani, Seyyed. *ENGINEERING DESIGN PROCESS*. 1st ed. 2005. Web. 7 Mar. 2015.
9. Slideshare.net. 'Fundamentals of Machine Design'. N.P., 2014. Web. 9 Mar. 2015.
10. Rajput, R. (2008). *A Textbook of Manufacturing Technology: (manufacturing processes)*. New Delhi: Laxmi.
11. 'Finite Element Analysis'. N.P., 2015. Web. 10 Mar. 2015.
12. Biomesh.org. 'FEA Basics | Bio mesh'. N.P., 2015. Web. 3 Mar. 2015.

13. Ulman, David. *The Mechanical Design Process*. 2nd ed. 2015. Print.
14. Sarcar, MM, MALLIKARJUNA RAO K, and LALIT NARAYAN K. 'Computer Aided Design and Manufacturing'. *Google Books*. N.P., 2015. Web. 5 Mar. 2015.
15. Tsompanakis, Yiannis, Nikos D Lagaros, and Manolis Papadrakakis. *Structural Design Optimization Considering Uncertainties*. London: Taylor & Francis, 2008. Print.
16. Matsumoto, K., T. Matsumoto, and Y. Goto. 'Reliability Analysis of Catalytic Converter as an Automotive Emission Control System'. (1975): n. page. Web. 12 Mar. 2015.
17. Katsura-r.com, 'Basic Knowledge of Rubber Rollers (1, 2): Katsura Roller Mfg. Co., Ltd, an All-Round Roller Manufacturer Specialized in Printing and Industrial Rubber Rollers.' Web. 11 Mar. 2015.
18. Menges, Matthew. *Seamless Roll Coverings for Coating, Cast-Film Production*. 1st ed. 2012. Web. 10 Mar. 2015.
19. Smooth-on.com. 'Durometer Shore Hardness Scale'. N.p. Web. 10 Mar. 2015.
20. Plasticsintl.com. 'Hardness Scale - Durometer Comparisons of Materials | Plastics International'. Web. 10 Mar. 2015.
21. Allsealsinc.com, 'Types Of Rubber And Basic Properties - All Seals Inc. - The Sealing Specialists'. Web. 10 Mar. 2015.
22. Globalspec.com. 'Rubber and Elastomer Molding Services Information on Globalspec'. Web. 10 Mar. 2015.

23. Mykin.com. 'Viton 75, Viton Properties, Viton Rubber - Mykin Inc.'. Web. 10 Mar. 2015.
24. Rollers, Rubber, and IQS Directory. 'Rubber Rollers Manufacturers Information'. *Iqsdirectory.com*. N.P., 2015. Web. 11 Mar. 2015.
25. Gray Rubber Roller for 8" Mecanum Wheel, w/ bushings and tube axle (am-0608). 'Gray Rubber Roller for 8'. *www.AndyMark.com*. N.P., 2015. Web. 10 Mar. 2015.
26. Thelibraryofmanufacturing.com. 'Metal Casting Process'. Web. 10 Mar. 2015.
27. Acpt.com. 'ACPT: Products: Rollers & Coreshafts'. Web. 11 Mar. 2015.
28. Astbearings.com. 'Roller Bearings - Cylindrical Bearings | AST Bearings'. Web. 10 Mar. 2015.
29. Wikipedia. 'Stamping (Metalworking)'. Web. 10 Mar. 2015.
30. Wikipedia. 'Progressive Stamping'. Web. 10 Mar. 2015.
31. Pannier.com. 'Rotary Stamping System for Marking Steel Plate'. Web. 10 Mar. 2015.
32. "50 Years of Customer Service Using Our Integrated Production of Stamping Die Manufacturing and Plating." Benefits of Stamping. N.P., n.d. Web. 10 Mar. 2015.
33. Ftbson.com. 'Metal Fabrication'. Web. 11 Mar. 2015.
34. Technologystudent.com. 'Joining Plates with Rivets'. Web. 11 Mar. 2015.
35. Spinning, Wenzel. 'Steel Vs Aluminum: Weight, Strength And Cost Differences | Wenzel Metal Spinning'. *Wenzelmetal spinning.com*. Web. 12 Mar. 2015.

36. Kang, Shao Hua, Xue Ling Zhang, and Ya Xie. 'Mechanics Analysis of Omni-Directional Mecanum-Wheel Based On FEM'. *AMM* 271-272 (2012): 1012-1016.  
Web.
37. Chiefdelphi.com. 'Chief Delphi - Mecanum and Omni Kinematic and Force Analysis and Programming'. Web. 11 Mar. 2015.