

The Space Congress® Proceedings

1967 (4th) Space Congress Proceedings

Apr 3rd, 12:00 AM

An Undersea Radioisotope Power Supply

H. C. Carney

Aerojet-General Corporation

Follow this and additional works at: <https://commons.erau.edu/space-congress-proceedings>

Scholarly Commons Citation

Carney, H. C., "An Undersea Radioisotope Power Supply" (1967). *The Space Congress® Proceedings*. 4. <https://commons.erau.edu/space-congress-proceedings/proceedings-1967-4th/session-18/4>

This Event is brought to you for free and open access by the Conferences at Scholarly Commons. It has been accepted for inclusion in The Space Congress® Proceedings by an authorized administrator of Scholarly Commons. For more information, please contact commons@erau.edu.

EMBRY-RIDDLE
Aeronautical University™
SCHOLARLY COMMONS

AN UNDERSEA RADIOISOTOPE POWER SUPPLY

H. C. Carney
Aerojet-General Corporation
San Ramon, California

Summary

The results and current status of an Aerojet-sponsored program to develop a product line of low-power radioisotope thermoelectric generators for marine applications are discussed. A 1-watt(e) Undersea Radioisotope Power Supply (URIPS) has been designed, fabricated, and tested. Extensive parametric studies were performed to select optimum design characteristics; typical parameters investigated were: radioisotope and chemical fuel form, thermoelectric material, fuel capsule L/D ratio, shield material and geometry, and operating conditions. The design emphasizes high reliability and low cost, but considerable emphasis was placed on adaptability to meet a wide spectrum of user requirements. URIPS is designed to provide a steady power output for a minimum of five years at ocean depths up to 20,000 feet.

Introduction

In 1965, Aerojet-General Corporation initiated a company-sponsored program to develop a product line of low-power radioisotope thermoelectric generators (RTG) for marine applications. The initial objective of this Undersea Radioisotope Power Supply Program was to design, fabricate, and test a highly reliable power supply capable of providing a continuous output of 1 watt(e) for a minimum of 5 years in ocean depths up to 20,000 feet.

Conventional primary chemical batteries, although less costly than an RTG have an endurance limit of several years; RTG systems have demonstrated the capability for 5 years of operating life and show promise of satisfying 10 to 20 year requirements. Optimum use of an RTG is in missions requiring a long-term unattended electrical power supply. For example, the longer life of the RTG more than offsets the lower capital cost of conventional batteries in cases where:

1. Costs associated with battery replacement are high, as in remote areas where access is difficult.
2. A complete battery-powered system must be periodically replaced because the system is not recoverable, resulting in high capital costs.
3. Power interruptions or physical disturbance during periodic replacement operations are unacceptable.

URIPS was developed to satisfy the indicated requirement for small, economical radioisotope thermoelectric generators suitable for powering scientific instrumentation, acoustic transponders,

cable repeaters, etc to support expanding ocean engineering activities. The first lead shield, radioisotope-fueled URIPS has been fabricated and tested, and was publicly exhibited at the Off-Shore Exploration Conference (OECON) at Long Beach, California in February of this year. A second lead shield URIPS has been purchased by the Navy and, following qualification testing, will be delivered to the Naval Civil Engineering Laboratory at Port Hueneme, California this summer. A compact, lightweight uranium-shield URIPS is currently in the final fabrication stage, and will be subjected to long term endurance testing at Aerojet.

Design Considerations

An RTG consists, basically, of an encapsulated radioisotope heat source, thermal insulation, biological shielding, a thermoelectric converter, a power conditioner, and various structural components.

Thermal energy from the radioisotope heat source is converted into low voltage d-c electrical power by the thermoelectric module. Thermal insulation is required to minimize parasitic heat loss. Radiation originating from the radioactive decay process requires the provision of a biological shield. A power conditioning sub-system is required to transform the low voltage, low current output of the thermoelectric module to the higher potential required by the load. Other functions of the power conditioner are to regulate the output voltage and power, by compensating for the fluctuation over the mission lifetime associated with the decay of the radioisotope and with the degradation in performance of the thermoelectric module. The electrical power can be used to charge a secondary battery system, or, alternately, an energy storage capacitor can be used, if required, to provide a low impedance source for a pulsing lamp or transducer load.

The interrelationship between the design variables associated with each of the components discussed above must be defined and systematically evaluated within the framework of established design goals and criteria to arrive at an optimum RTG design. The major URIPS design goals were low cost, and high reliability. The design criteria, while of similar importance but which are in some cases subject to overriding constraints imposed by the design goals, were:

1. Minimum size and weight.
2. Optimum design for a power range capability from 150 milliwatts to 5 watts.
3. Adaptable to a wide variety of applications with minimum design modifications.
4. Minimum unattended lifetime of 5 years and potential capability of 10 to 20 years.
5. Capable of immersion in sea water at depths up to 20,000 feet.
6. Capable of withstanding all foreseeable environmental conditions during storage, transportation, handling, and operation without mechanical or electrical damage or degradation in rated performance.
7. Capable of complying with all safety regulations specified in applicable local, state and federal ordinances, laws, and codes concerning manufacture, transportation, handling, testing, operation, and disposal.

Design Selection

An extensive parametric analysis of RTG design characteristics and operating parameters was performed during the conceptual design phase of the URIPS program, to select optimum design features consistent with the previously described goals and criteria. The results of the studies concerned with fuel, shielding, thermoelectric materials, and thermal insulation selection, and overall RTG system optimization are summarized below. The parametric analyses were performed using an IBM 7094 computer program developed by Aerojet under the AEC sponsored Advanced Large Milliwatt Generator Program.¹ This Thermoelectric Heater Evaluation (TEHE-3) code optimizes the performance of an RTG and calculates the corresponding physical characteristics and associated costs.

Radioisotope Fuel

All radioisotopes currently under development by the AEC for heat source applications were evaluated. In consideration of the design criteria requiring a minimum unattended lifetime of 5 years (and the capability for as long as 20 years), the candidate radioisotopes were restricted to those with half-lives in excess of 5 years; these included Co⁶⁰, Sr⁹⁰, Cs¹³⁷, Pu²³⁸, and Cm²⁴⁴. Cobalt-60 and strontium-90 proved to be the most competitive for URIPS application on the basis of fuel cost and availability. Strontium-90 was selected since it results in the lowest overall system cost, weight, and size. Most of the Co-60 decay energy is released as gamma photons, and since these are penetrating radiations, much of the energy is deposited outside the fuel capsule in surrounding material. Consequently, a thermal shield equivalent to approximately one inch of uranium must be placed immediately surrounding the fuel to absorb the photon energy. This shield reduces the effective power density of the heat source (which increases system size and parasitic thermal losses), and reduces design flexibility. In addition, the total biological

shield thickness required for Co⁶⁰ is approximately twice that for Sr⁹⁰ for this low power system, which results in a considerably heavier shield and more costly system. The titanate fuel form of strontium (SrTiO₃) was selected because of its advanced development status, availability in sufficient quantity, and relatively low solubility in water, which is advantageous from the hazards standpoint.

Thermoelectric Material

A large number of thermoelectric materials were evaluated for URIPS application (see Table 1). System electrical efficiency, η_E , which includes both the thermoelectric module and power conditioner efficiency, was approximated to provide a temperature-dependent analytic function for the TEHE-3 code by using an effective (psuedo) thermoelectric figure of merit, Z_E , in the basic thermoelectric efficiency equation for matched load conditions:

$$\eta_E = \frac{T_H - T_C}{2T_H + \frac{4}{Z_E} - \frac{T_H - T_C}{2}}$$

where:

- T_H = hot junction temperature ($^{\circ}\text{K}$)
- T_C = cold junction temperature ($^{\circ}\text{K}$)
- Z_E = effective figure of merit ($^{\circ}\text{C}^{-1}$)

The effective figure of merit characteristic of each thermoelectric material (see Table 2) was determined by computing detailed performance maps relating electrical efficiency to thermoelectric operating parameters and design characteristics. These computer programs are also described in Reference 1. Typical results, showing the system diameter, weight, and efficiency as a function of Z_E for a 1-watt(e) and 150 milliwatt(e) RTG are shown in Figures 1 and 2.

TABLE 1
CANDIDATE THERMOELECTRIC MATERIALS
FOR URIPS APPLICATIONS

Bismuth Telluride, N/P-Type (Asarco)
Lead Telluride, N-Type (MMM-TEGS-3N)
Lead-Tin-Telluride, P-Type (MMM-TEGS-3P)
Lead Telluride (MMM-TEGS-2N/2P)
MCC 40, N/P-Type (Monsanto)
Silicon Germanium Alloy, N/P-Type (RCA)
Cupron Special (Wilbur B. Driver)
Tophel Special (Wilbur B. Driver)
Platinel 7674 N (Engelhard Industries)
Platinel 5355 P (Engelhard Industries)
Chromel - P (Hoskins)
Constantan (Driver-Harris)

TABLE 2

PERFORMANCE PARAMETER FOR THERMOELECTRIC MODULES

Thermoelectric Material	Effective Figure of Merit, $Z_E \times 10^3 \text{ } ^\circ\text{C}^{-1}$
Cupron/Tophel Special	0.10
MCC-40	0.25
SiGe Alloy	0.30
PbTe (3N/3P)	0.40
SiGe-PbTe (2N/2P) Cascaded	0.45
PbTe (2N/2P)	0.55
PbTe (2N/2P) - Bi_2Te_3 Cascaded	0.65
Bi_2Te_3	0.90

The metallic thermoelectric materials are inefficient, and result in a relatively large system size, weight and cost. The metallic materials are best suited for low milliwatt (less than 150 mw) applications, where current fabrication limitations restrict the performance capability of semiconductor materials. Silicon-germanium is basically a high temperature material which cannot be usefully employed in a low power RTG because of the comparatively large parasitic heat losses associated with the temperatures required to achieve high thermoelectric conversion efficiency. Lead telluride and bismuth telluride were found to be the most competitive material currently available for URIPS use. Segmented and cascaded systems which perform better than the simple non-segmented thermoelements were investigated; however, the segmented technology is currently in the developmental stage and not yet suitable for application in commercial low power systems requiring high reliability and long endurance. Bismuth telluride was selected for use in URIPS in preference to lead telluride for the following reasons:

1. RTG cost, size, and weight are less for a power range up to 2 watts and competitive to 5 watts.
2. Bismuth telluride operates efficiently at low temperatures, which maximizes the overall system reliability.
3. Thermoelements with large length-to-area (L/A) ratios have been fabricated into commercially available compact thermoelectric modules which match the electrical load characteristics of low power RTG and provide a relatively high output voltage and correspondingly high power conditioning efficiency.
4. The relatively low operating temperature permits separate encapsulation of the thermoelectric module from the thermal insulation system in a high purity, inert gas environment without excessive parasitic heat losses.

Biological Shield

Minimum RTG size and weight are always attractive features because such characteristics normally simplify user integration problems. Two typical shield materials were evaluated: lead, which is representative of minimum cost for a reasonably compact, integral shield; and uranium, which minimizes size and weight. Three basic shield configurations were investigated: internal shield; external shield; and split shield (a partial internal uranium shield and partial external uranium or lead shield), as illustrated in Figure 3. Lead cannot be used as an internal shield because the fuel capsule temperatures typically exceed the melting point of lead. All shields were sized to result in a radiation dose rate no greater than 200 mr/hr at the surface of the RTG, which is consistent with ICC/AEC shipping regulations. The results of these investigations, presented in Figure 4, lead to the following conclusions:

1. Minimum RTG diameter is obtained with an external uranium shield.
2. Weights of the external and internal uranium shield are approximately equal for a 1-watt(e) RTG but uranium split shields are heavier than either an external or internal uranium shield.
3. Partial external lead shielding increases the system weight, reaching a value about twice that of uranium for the full external lead shield.

In addition, the efficiency of an external shield system is approximately twice that of an internal shield because the parasitic heat losses are minimized by placing the insulation immediately around the heat source. This configuration results in minimum system cost, and was therefore selected as reference for URIPS. Of equal importance, any one of a number of shield materials (including an expedient, rather than an integral shield) can be applied as the external shield with minimum design modifications, since thermal management is accomplished, primarily, inside the shield. Selection of a compact uranium shield or low cost lead shield URIPS depends on the user's cost/effectiveness requirements.

Fuel Capsule Length/Diameter Ratio

The effect of fuel capsule L/D ratio on RTG performance was investigated to determine the optimum values for minimum weight and maximum efficiency (which are directly related to minimum system cost). Results of the TEHE-3 analysis are summarized in Figure 5 for a 1-watt(e) RTG. A fuel capsule L/D ratio of 1.2 is optimum; however, weight and efficiency do not vary appreciably throughout an L/D range of 1.0 to 1.5.

Thermal Insulation

Thermal conductivity is the most important physical property in the selection of insulation materials for RTG application. A low conductivity is required to minimize parasitic heat losses and the thickness of insulation required. The thermal conductivity of a number of insulation materials listed in Table 3, are compared in Figure 6. Min-K 1301, backfilled with xenon, represents the best of the non-evacuated fibrous insulation materials (Min-K 501 is somewhat better but is limited to a 400-500°F operating temperature). Super Linde Insulation is far superior to any of the fibrous materials but must be evacuated and, for long duration usage, getter systems are required to control outgassing and maintain a vacuum of about 10^{-3} torr. In view of the developmental status of vacuum insulations and of the high associated cost, Min-K 1301 was selected for use in URIPS.

URIPS Design Description

The 1-watt(e) uranium-shielded system (URIPS-U1) and lead-shielded system (URIPS-Pl) designs are shown in Figures 7 and 8, respectively. The cylindrical source capsule consists of a hot-pressed strontium titanate pellet encapsulated in Hastelloy C. The bellows-encapsulated Bi_2Te_3 thermoelectric converter is pressed against one end of the heat source with contact pressure applied by springs in the converter. The source capsule is radially and axially supported by the Min-K 1301 thermal insulation which surrounds the heat source and thermoelectric converter. The insulation space is backfilled with xenon during final assembly to minimize parasitic heat loss and long-term degradation of the thermal insulation.

In URIPS-U1, the uranium acts as both the biological shield and pressure vessel, but a steel pressure vessel is required in URIPS-Pl. Both systems are encased in a 70/30 copper-nickel (0.5 Fe) alloy housing for protection against the corrosive sea water environment.

Radioisotope Heat Source

The 46 watt heat source consists of 7200 curies of strontium-90 titanate. The hot pressed fuel is sealed into a Type 304L stainless steel liner and encapsulated in Hastelloy C. The capsule is designed to withstand an external pressure of 10,000 psi with negligible permanent deformation of the walls or end caps in sea water for 300 years (in excess of ten half-lives of Sr^{90}), based on an average corrosion rate for Hastelloy C of 1×10^{-4} in./year. Pressure tests showed that the empty capsule will withstand an external pressure of 15,000 psi before rupture throughout the same decay period. Figure 9 shows the basic heat source components.

Thermal Insulation

The radioisotope heat source and thermoelectric converter are surrounded by Min-K 1301 thermal insulation. The insulation, which has a relatively high compressive strength, mechanically supports the fuel capsule and minimizes parasitic

heat losses. The as-received insulation is in block form and contains a small percentage of volatiles, consisting of phenolic binder compounds and bound moisture. It is not necessary to remove these volatiles to protect the thermoelectric material, since the power module is separately encapsulated and maintained in a high purity argon atmosphere. However, the insulation is heat-treated to remove volatile contaminants for the following reasons:

1. The compressive strength is increased.
2. The thermal conductivity is decreased.
3. Long-term degradation of thermal properties is reduced.
4. The insulation is more easily machined to close tolerances.

Several URIPS insulation assemblies were subjected to shock and vibration tests. As a result of these tests, the insulation-capsule support structure is qualified to meet the transportation shock and vibration requirements for common carrier as specified by MIL-STD-810A. In addition, the insulation structure successfully sustained a transverse axis shock pulse of 50g, which was applied to simulate a shipboard handling event.

Thermoelectric Converter

The thermoelectric converter consists of an encapsulated assembly of the bismuth telluride power module. The module is encapsulated in a bellows container filled with high purity argon, to isolate the module from contaminants evolved by the thermal insulation. In addition to improving the lifetime and reducing performance degradation of the thermoelectric module, separate packaging facilitates pre-assembly performance and qualification testing of the converter.

The URIPS converter is comprised of two Asarco TH1010 thermogotron power generation modules thermally and electrically-connected in parallel. These miniaturized modules incorporate close-packed, sintered bismuth telluride thermoelements. A photograph of the TH1010 module and converter assembly is shown in Figure 10, and module design and performance characteristics are summarized in Table 4. The performance characteristics of 22 TH1010 modules were experimentally evaluated to verify fabrication reproducibility. Four converters have been fabricated and subjected to performance and qualification tests.

Housing Assembly

The housing assembly for both the URIPS-Pl and URIPS-U1 is comprised of the main housing, housing cap, flange, electrical connector, and lifting lugs. The housing cap is bolted to the flange and a neoprene O-ring used for the primary seal. The lifting lugs are welded to the main housing, and the body of the electrical receptacle and main housing are welded to the flange.

TABLE 3
INSULATION MATERIALS LIST

No.	Product Name	Supplier	Density lbs/ft ³	Max. Cont.	Interstitial Gas	Gas Pressure (mm Hg)	Data Source
				Service Temperature °F			
1A	Improved Min-K-2000	Johns-Manville	14	2000	Air	760	J/M Survey Data
1B	" "	"	14	2000	He	760	" " "
1C	" "	"	14	2000	Air	55	" " "
1D	" "	"	14	2000	He	55	" " "
1E	" "	"	14	2000	Air or He	8	" " "
1F	" "	"	20	2000	Air	760	" " "
1G	" "	"	20	2000	He	760	" " "
1H	" "	"	20	2000	Air	55	" " "
1I	" "	"	20	2000	He	55	" " "
1J	" "	"	20	2000	Air or He	8	" " "
2	Min-K 1301	"	20	1450	Air	760	" " "
2A	"	"	20	1450	Xenon	760	" " "
3A	Micro-Quartz Type I	"	6	2000	Air	760	J/M Literature
3B	"	"	3.5	2000	Air	760	" "
3C	"	"	3.5	2000	He	760	J/M Lit. & G/D Corr.
3D	"	"	3.5	2000	Air	High Vacuum	"
4A	Micro-Quartz Type II	"	4.5	2750	Air	760	J/M Survey Data
4B	"	"	6.2	2750	Air	760	" " "
4C	"	"	8.0	2750	Air	760	" " "
5A	Thermoflex RF 600	"	6	2000	Air	760	J/M Literature
5B	" RF 300	"	3	2000	Air	760	" "
6A	Refrasil Batt B-100	H.I.Thompson	3	2000	Air	760	G/D Ft.Worth Rept.
6B	" " A-100	" "	3.5	2000	Air	760	Hitco Literature
6C	" " B-100-1	" "	6	2000	Air	760	" "
7A	S.I.62 Compressed (1 atm)	Linde	28		Air	High Vacuum	Linde Literature
7B	Hi. Temp. S.I.	"	≈18	≈1800	Air	"	G/D & Linde Data
8A	Foamsil	Pittsburgh-Corn.	11	2200	Air	760	Pitt.-Corn. Lit.
8B	"	"	10	2200	Air	760	ASD-TDR 62-215
9	X226-32A Foam	American Latex	2	<400	Air	760	G/D Rept.MRG-202
10	Zirconia-A Fiber	H.I. Thompson	8	3000	Air	760	Hitco Rept. AF-33(657)3902
11A	ADL-17	A. D. Little	12		Air	760	Bell Survey Data
11B	ADL-17	" " "	12		Air	0.5	" " "
12A	Fiber Frax Blanket	Carborundum	6	2300	Air	760	Carb. Survey Data
12B	Fiber Frax Paper	"	9.5	2300	Air	760	" " "
13	Micro-Quartz Type II & Platinum Foils		6.2	2750	Air	8	G/D Calc. Data
14	"Santocel" A	Monsanto	5	1300	Air	760	Monsanto Lit.
15	Kaowool Paper	B & W	12-13	2300	Air	760	B&W Literature
16	Foamglas	Pittsburgh-Corn.	9	800	Air	760	P-C Literature
17	"Tipersul" Block	DuPont		2000	Air	760	DuPont Lit.
18	PKT	DuPont	32	1800	Air	760	" "
19	WRP-X	Refractory Prod.	18	2200	Air	760	RPC Lit.
20	Min-K 501	Johns-Manville	10	500	Air	760	J/M Literature
21	Dyna-Quartz	"	10	2750	Air	760	" "
22	MT-10	Eagle-Picher		800	Air	760	EP Data
23	Min-KF-100-10	Johns-Manville	10	1200	Air	760	J/M Literature
24	Eccospheres SI	Emerson & Cuming, Inc.	11	2500	Air	760	E&C Literature
25	PV Supertemp Block	Eagle-Picher		1900	Air	760	EP Data
26	Solami	Solar Aircraft	40	1800	Air	760	Solar Data
27	Xenon Gas						

TABLE 4

CHARACTERISTICS OF ASARSO TH1010 POWER MODULES

Thermoelectric Material Sintered Bismuth Telluride	
Density, g/cc	
N-type	7.70
P-type	6.76
Melting Points, °C	
N-type	
Liquidus	592
Solidus	587
P-type	601 ± 3
Number of Couples	50
Electrical connection	Series
Module Dimensions, in.	
Length	0.750
Width	0.750
Thickness	0.210
Element Dimensions, in.	
Square cross-section	0.060
Length	0.200
Nickel barrier thickness, in.	0.0005
Copper link thickness, in.	0.005
Epoxy perimeter thickness, in.	0.0545
Insulation thickness, in.	0.005
Internal resistance (R.T.), ohms	2.9 ± 0.3
Performance (T _H = 210°C, T _C = 30°C)	
Open circuit voltage, volts	3.0 - 3.2
Short circuit current, amps	0.80 - 0.88
Internal resistance, ohms	3.5 - 3.8
Thermal efficiency, %	5.0 - 6.0
Maximum power, watts	0.6 - 0.7

The housing assembly, which includes all components with surfaces exposed to sea water, is fabricated from 70/30 copper-nickel alloy (0.5 Fe). This material, which has excellent resistance to corrosion, pitting, and fouling in sea water, is commonly used for the most severe service where reliability and dependability are paramount. The nominal corrosion rate is 0.1 to 1.5 mils per year with a typical rate of penetration in pits of 1 to 5 mils per year for a sea water velocity of 0 to 3 ft/sec.² The results of corrosion tests performed on copper-nickel alloy (CDA No. 715) in the Pacific Ocean, 75 to 80 miles west of Port Hueneme, California,³ are shown in Table 5.

TABLE 5

CORROSION DATA FOR 70/30 COPPER-NICKEL ALLOY

Depth Feet	Exposure Days	Environment	MDD	MPY
5640	123	W	7.36	1.11
5640	123	M	4.95	0.80
2500	123	W	3.89	0.63
2340	197	W	4.39	0.71
2340	197	M	1.29	0.21
W	Exposed in sea water			
M	Partially embedded in bottom sediment			
MDD	Milligrams per square decimeter per day			
MPY	Mils penetration per year			

Power Conditioning Unit

It is difficult to obtain the optimum impedance match to the load for maximum efficiency with semiconductor-type thermoelements for low power output thermoelectric generators because of materials fabrication limitations. As a consequence, a power conditioning subsystem is required to transform the low voltage, low current output obtained from an electrically-matched thermoelectric module to the higher potential required by the load. Other functions of the power conditioner are to regulate the output voltage and power by compensating for fluctuations that occur over the mission lifetime due to radioactive decay and performance degradation. The electrical circuit used in URIPS to condition the output power from the thermoelectric converter is shown in Figure 11. The power conditioner is completely sealed in plastic. Space-rated, high reliability electronic components with certified reliability history, and operation under derated conditions assures a high reliability for this subsystem.

Design Summary

Overall URIPS design characteristics are summarized in Table 6. The first Aerojet Undersea Radioisotope Power Supply is shown in Figure 12 being readied for tests. Development efforts are continuing to increase the overall system reliability by the application of redundancy concepts in the thermoelectric converter.

TABLE 6
URIPS DESIGN SUMMARY

Radioisotope fuel		SrTiO ₃
Power output		1-watt(e), 24-volts
Minimum design life		5 years
Thermal power (BOL)		46 watts
Thermal efficiency (EOL)		2.5%
Power conditioning efficiency		80%
Shield material	Depleted uranium	Lead
Diameter of system	9.7 in.	13.7 in.
Height of system	15.2 in.	19.7 in.
Weight	450 lb	800 lb
Housing		
Material	70/30 Copper-Nickel	70/30 Copper-Nickel
Thickness	0.25 in.	0.25 in.
Thermal insulation material		Min-K 1301
Fuel capsule material		Hastelloy C
Thermoelectric module		
T/E material		Bi ₂ Te ₃ N/P
Hot junction temperature		400 ^o F
Cold junction temperature		75 ^o F
T/E output voltage		1.6 volts
No. of couples in series		50
Radiation dose rate		Less than 200 mr/hr surface and 10 mr/hr at one meter.
Security		All aspects of URIPS are unclassified
Licensing		Packaging conforms to ICC/AEC shipping regulations

References

1. Aerojet-General Nucleonics, Large Milliwatt Generator Program - Parametric Study Data, Report No. AGN-8182, Vols. I and II, March 1966, San Ramon, California.
2. Corrosion Handbook, H. H. Uhlig, John Wiley & Sons, Inc., N.Y., 1948.
3. Fred M. Reinhart, "Effect of Deep Ocean Environments on the Corrosion of Selected Alloys", Tech. Note N-781, NCEL, October, 1965.

1.0 watt - SrTiO_3 - External Full U-Shield - MIN-K-1301 - L/D 1.2 - TC 75

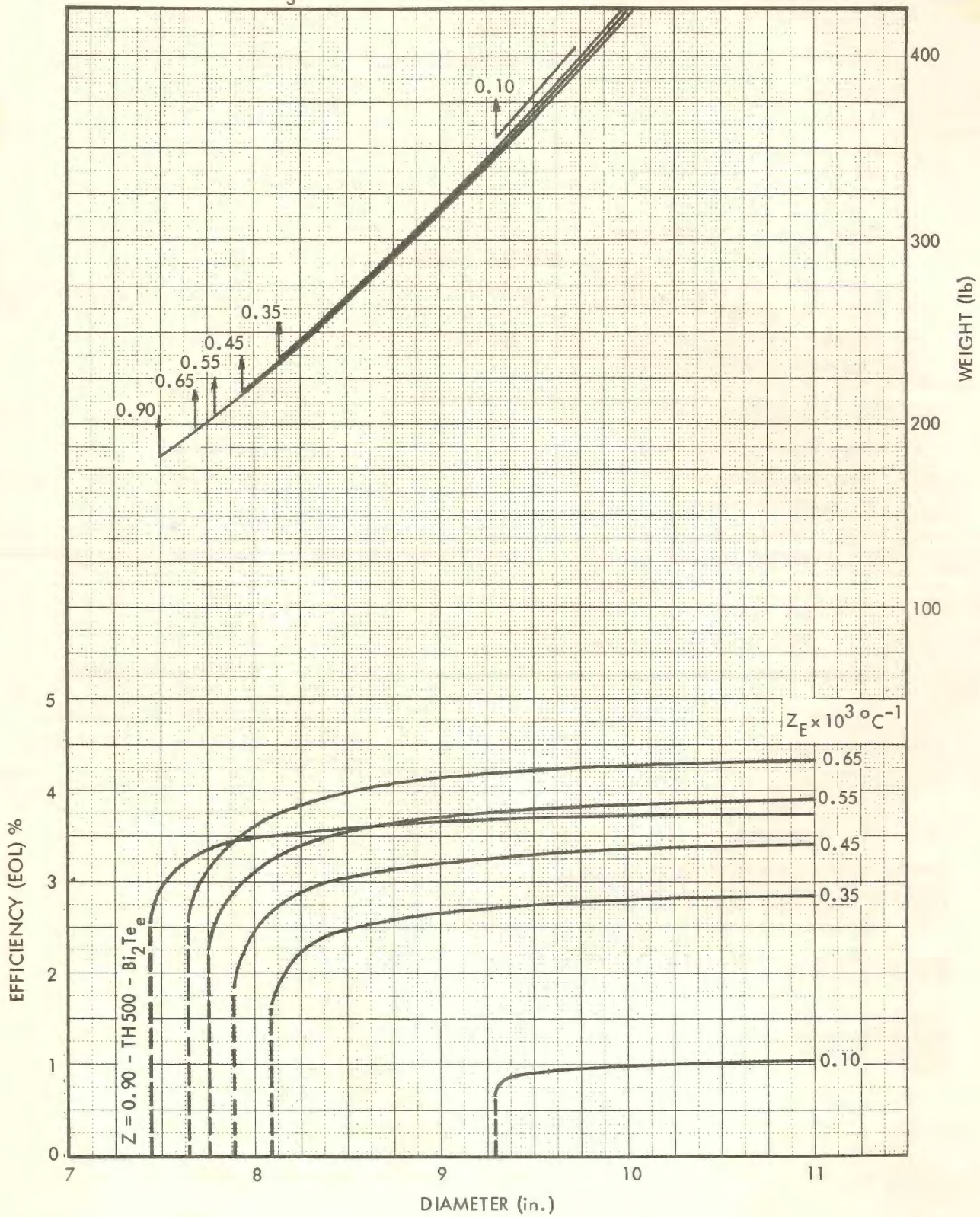

Figure 1. Effect of Thermoelectric Material on 1-Watt RTG Performance

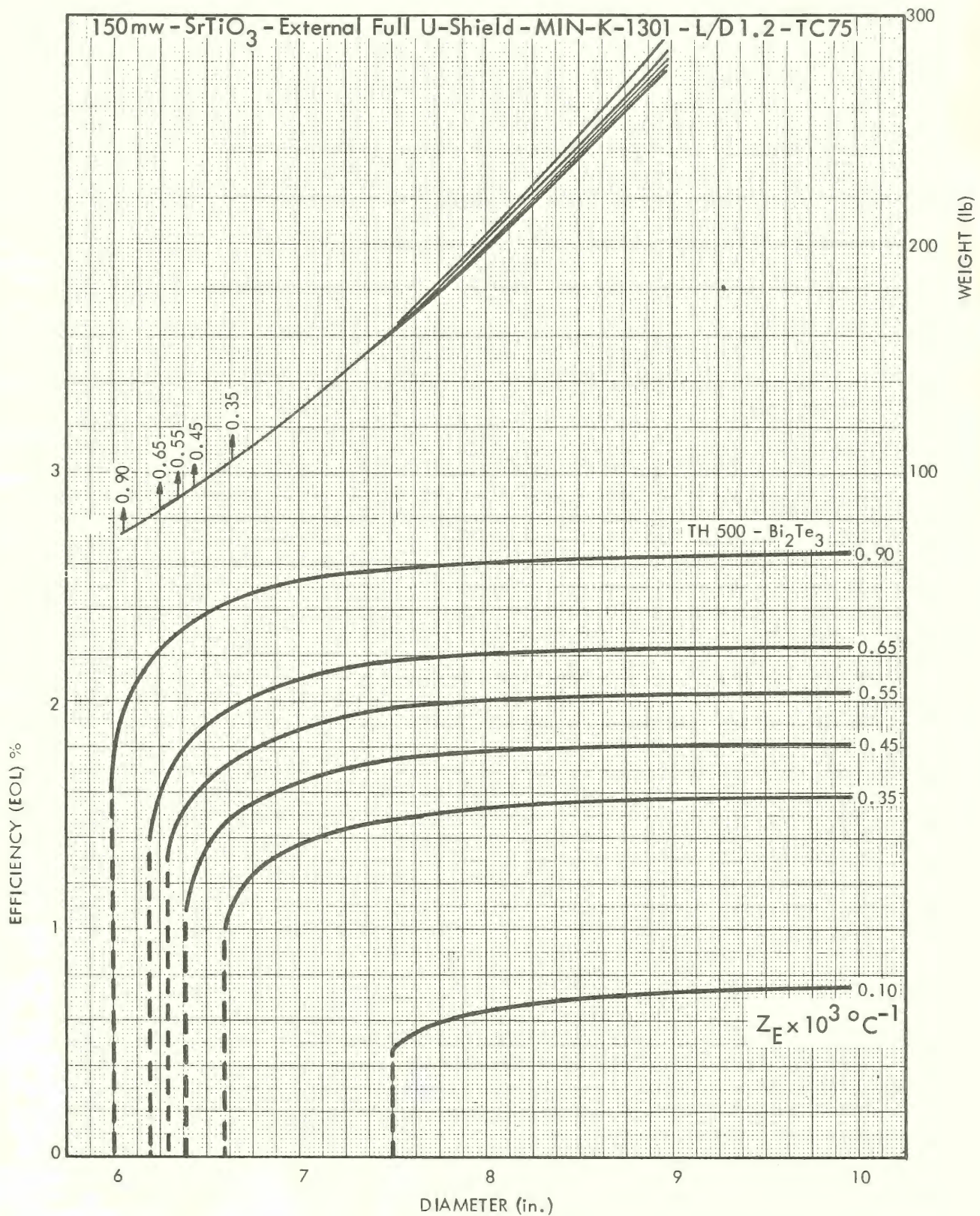
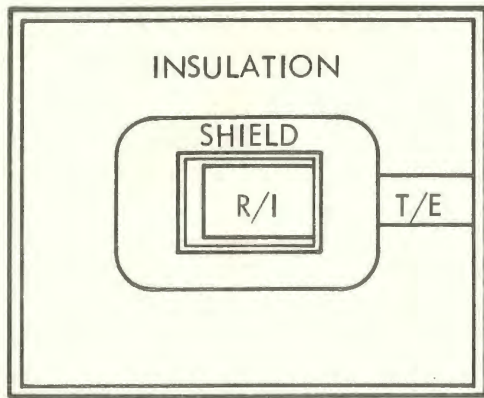
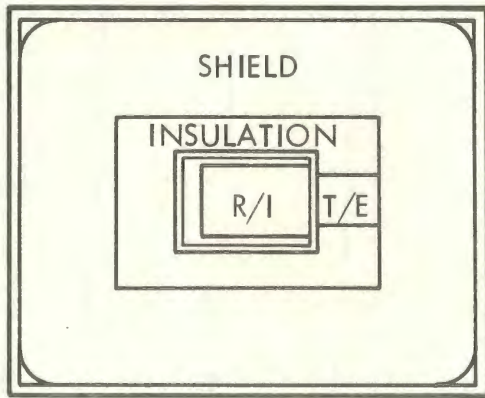

Figure 2. Effect of Thermoelectric Material on 150-Milliwatt RTG Performance



INTERNAL SHIELD



EXTERNAL SHIELD

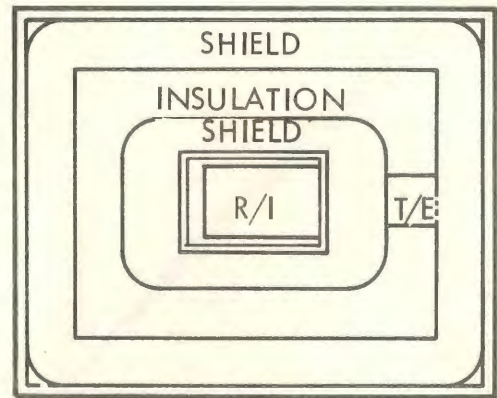

SPLIT SHIELD

Figure 3. Typical RTG Shield Configurations

○ FULL EXTERNAL SHIELD THERMOELECTRIC MATERIAL - Bi_2Te_3
 ▲ FULL INTERNAL SHIELD THERMAL INSULATION - MIN-K-1301
 FUEL CAPSULE L/D - 1.2
 FULL SHIELD - 200mr/hr AT SURFACE
 COLD JUNCTION TEMP - 75°F
 MAX HOT JUNCTION TEMP - 450°F

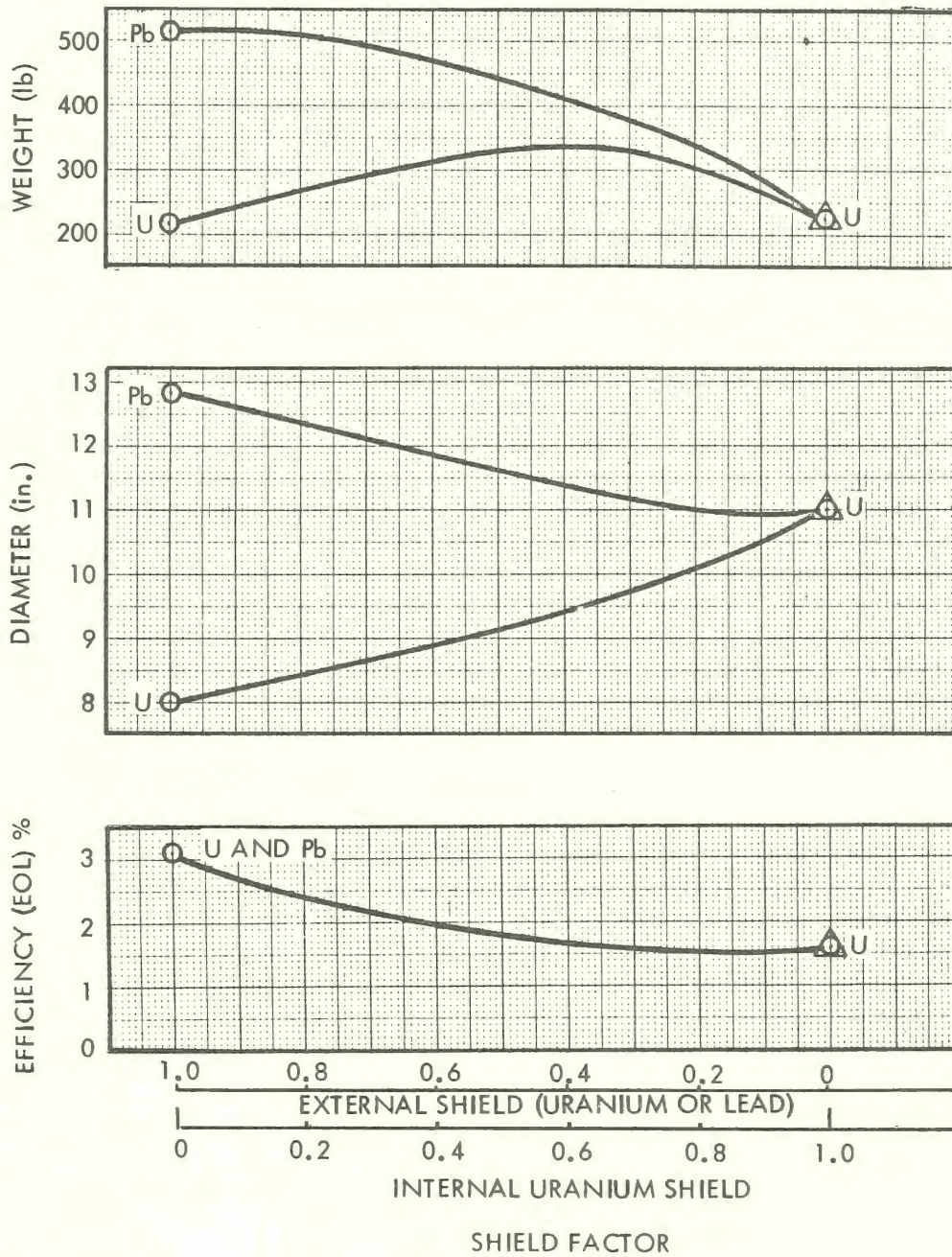

Figure 4. Optimum Design Parameters for 1-Watt RTG as a Function of Shield Configuration

1.0 watt - SrTiO₃ - External Full U-Shield - MIN-K-1301 - Z 0.90 - TC 75 - Bi₂Te₃

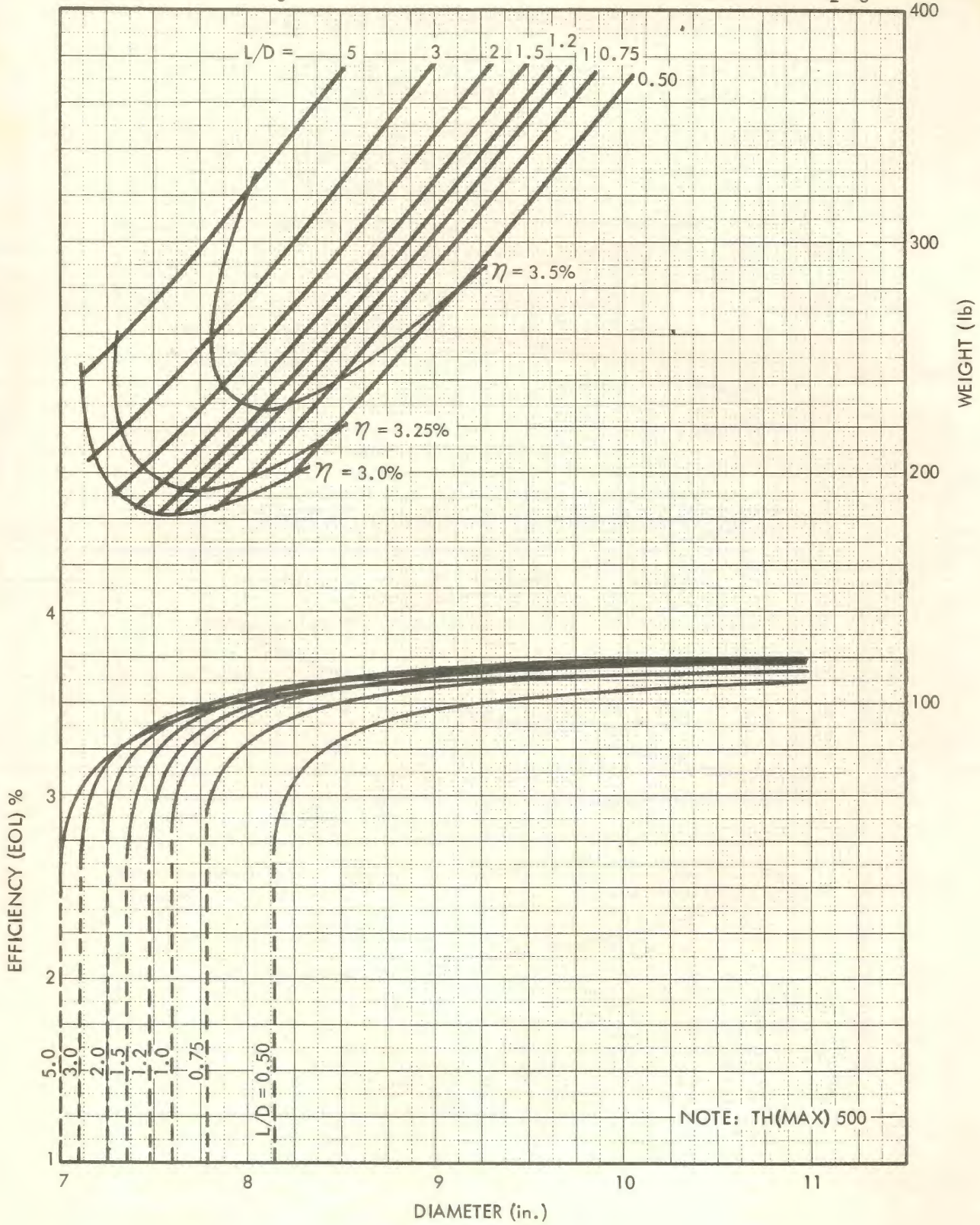

Figure 5. Effect of Fuel Capsule L/D on 1-Watt RTG Performance Parameters

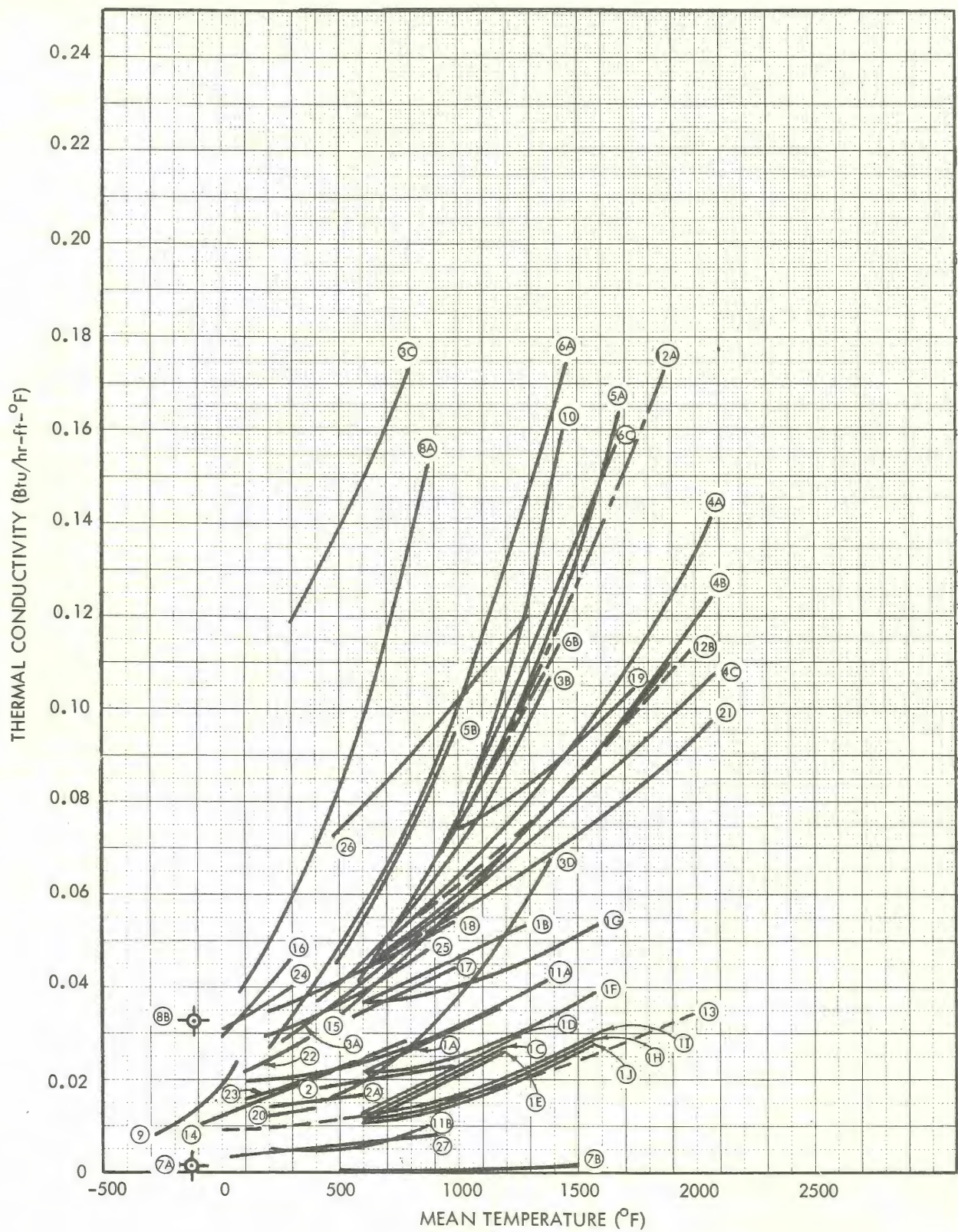

Figure 6. Thermal Conductivity of Insulation Materials

1 WATT(e) URIPS-U1, DEPLETED URANIUM SHIELD

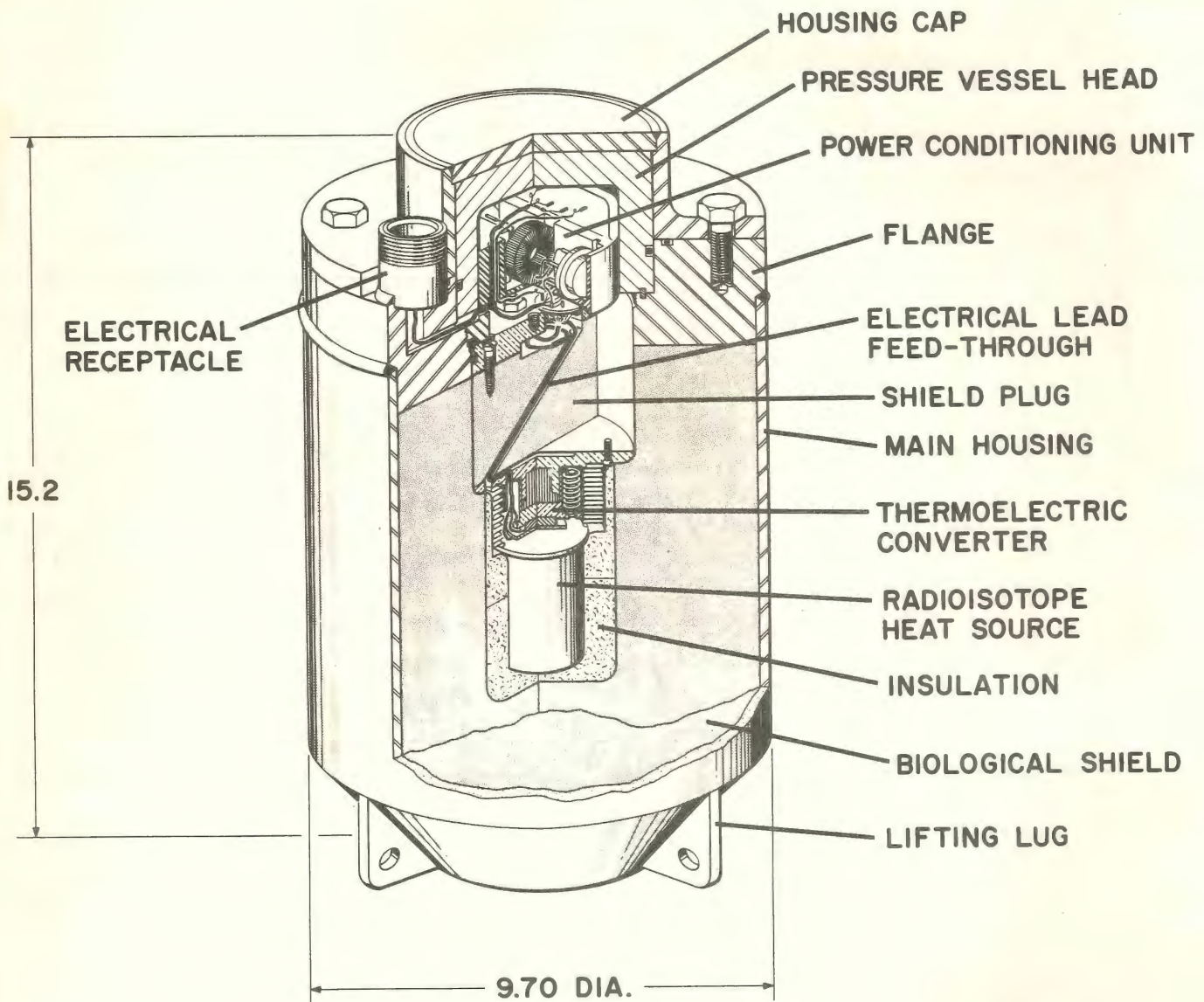

Figure 7. 1-Watt(e) URIPS-U1, Depleted Uranium Shield

1 WATT(e) URIPS-P1, LEAD SHIELD

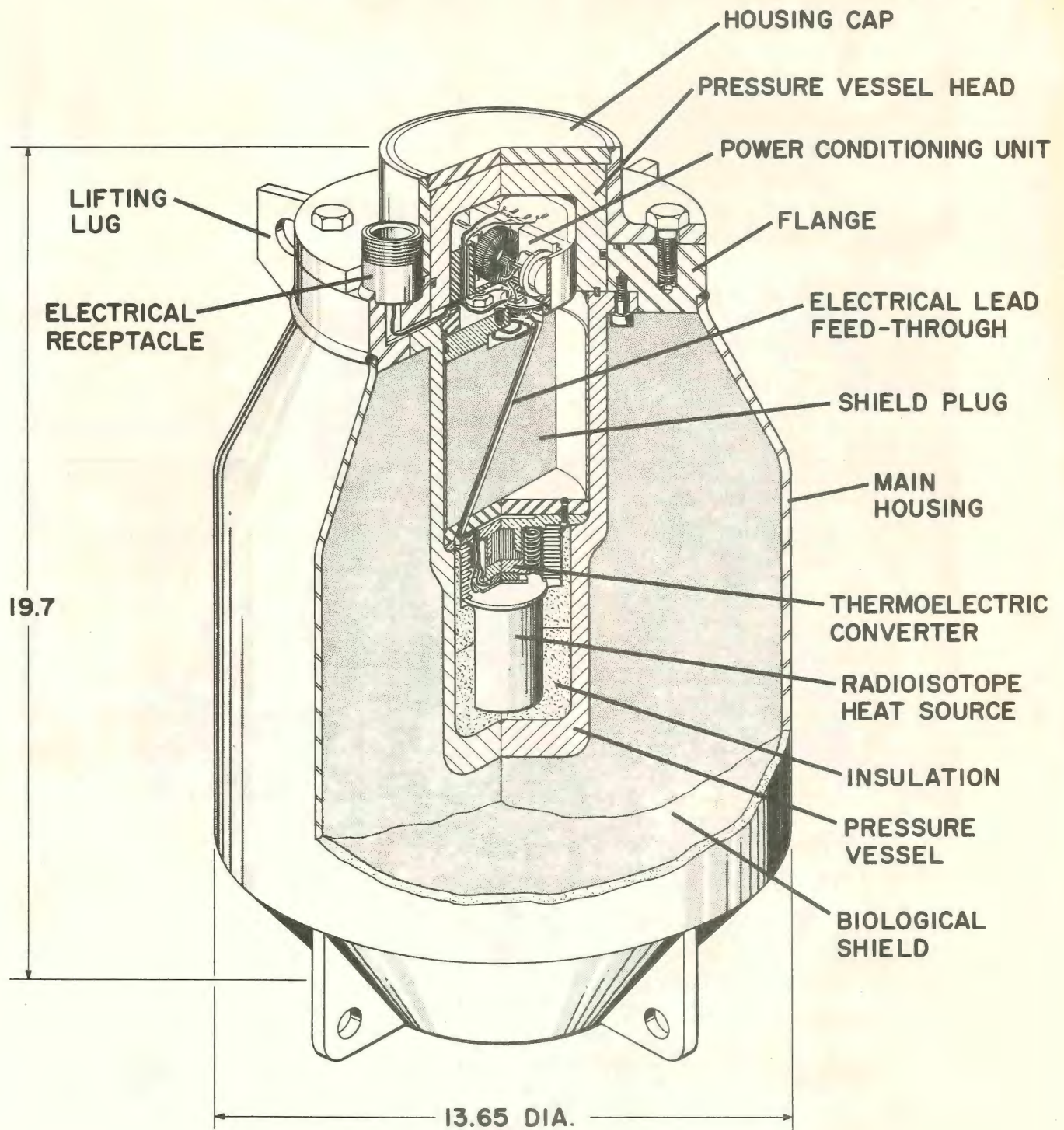

Figure 8. 1 Watt(e) URIPS-P1, Lead Shield

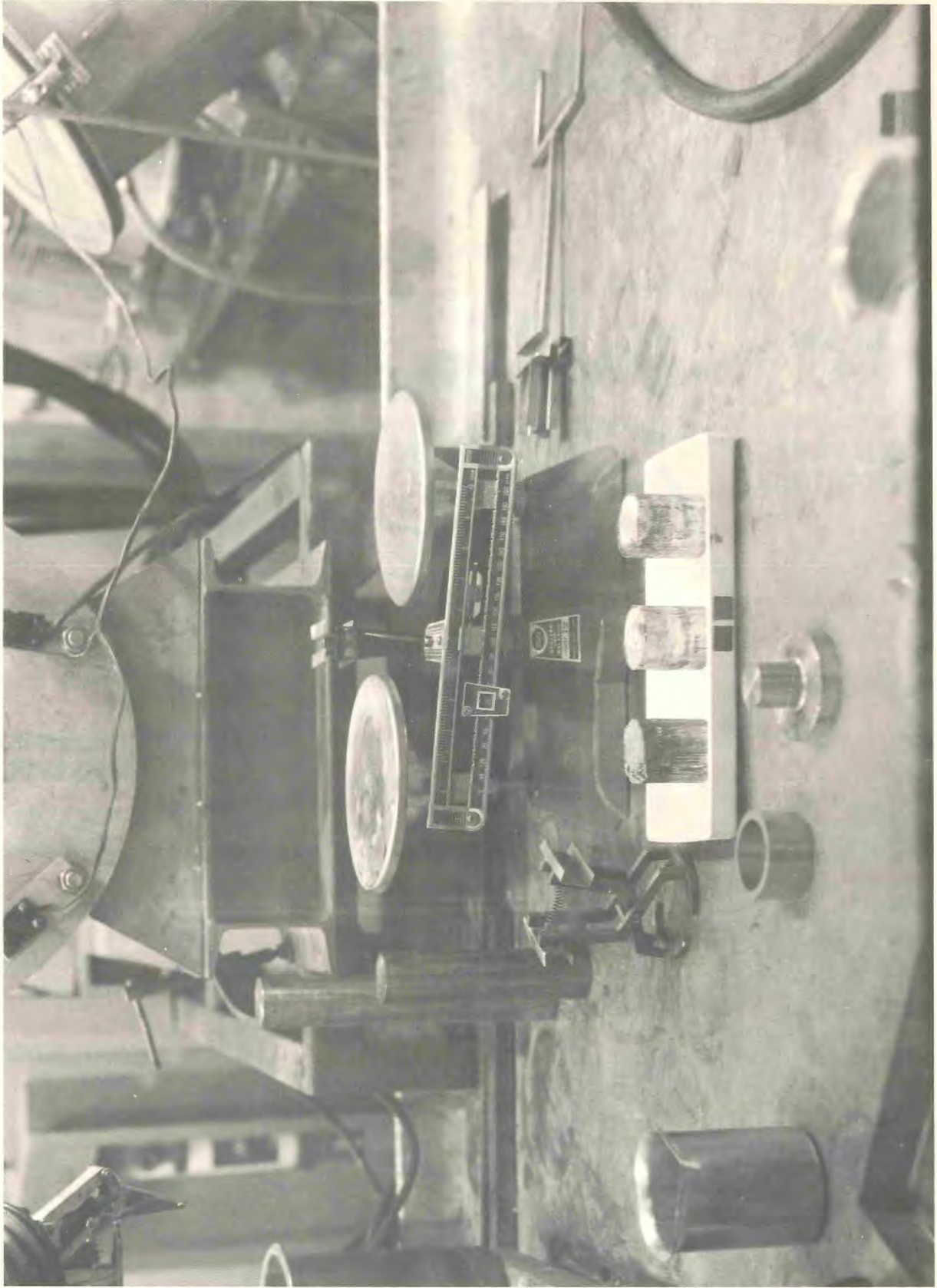

Figure 9A. Strontium Titanate Fuel Pellets

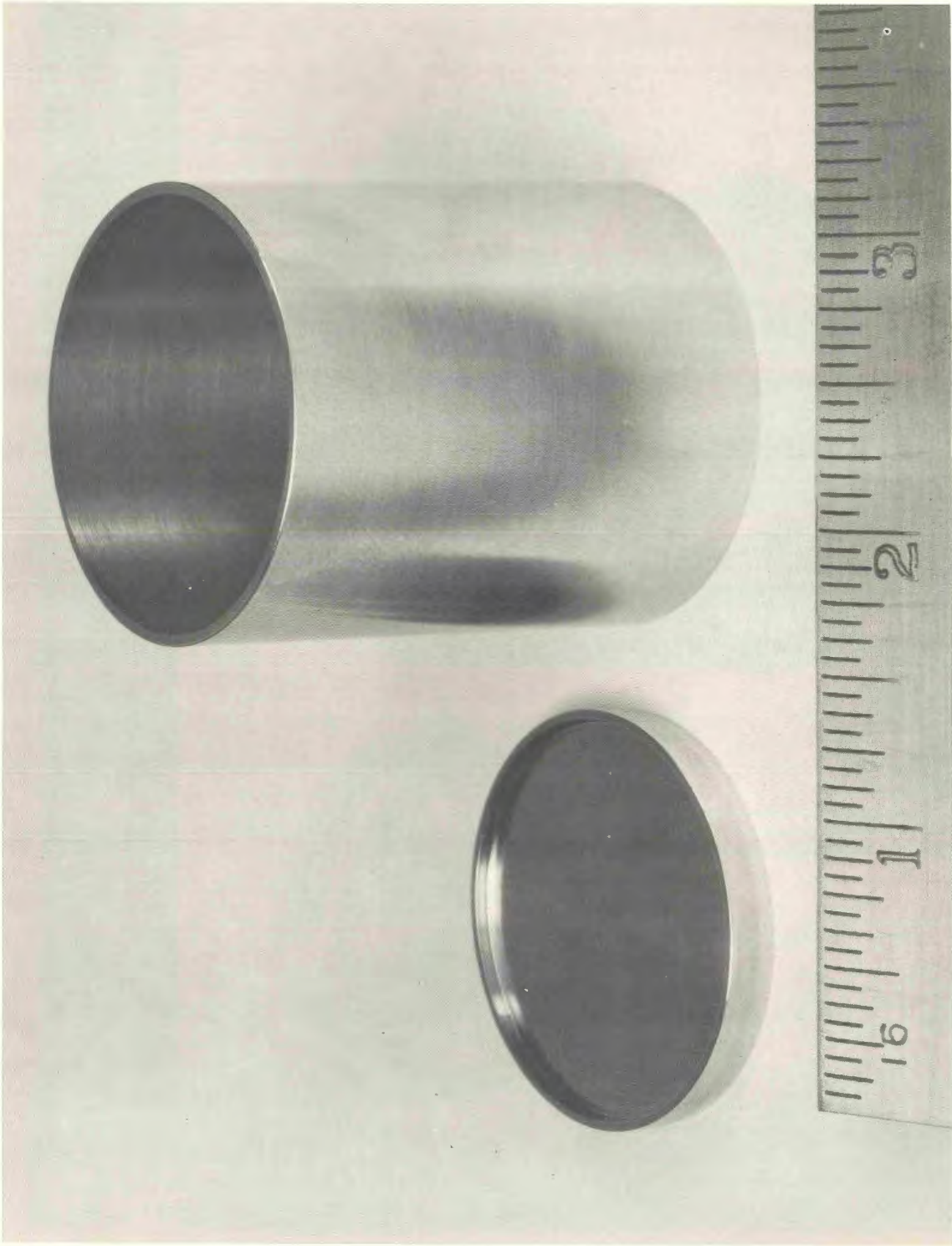

Figure 9B. Stainless Steel Fuel Liner

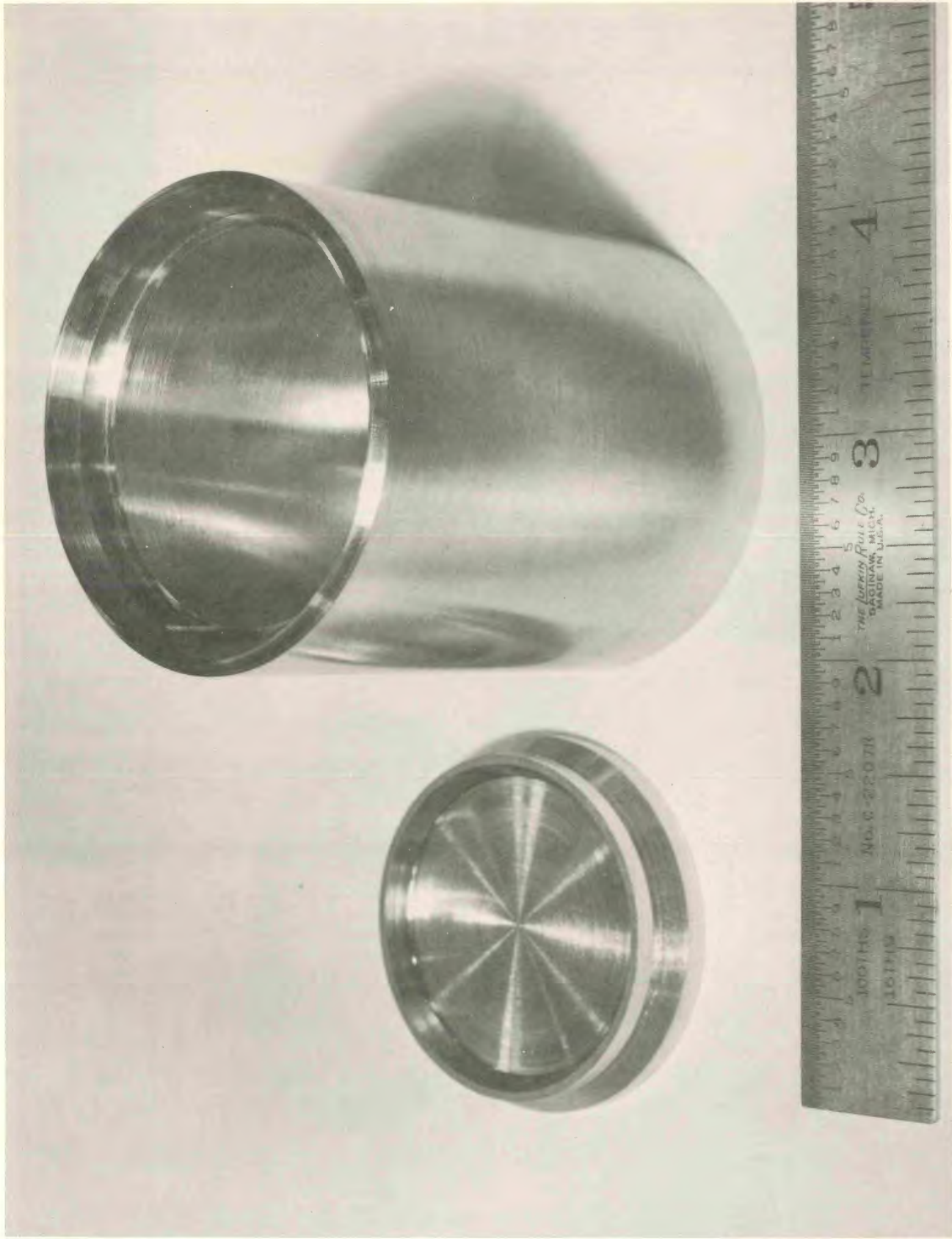

Figure 9C. Hastelloy C Fuel Capsule



Figure 9D. Welded Strontium Titanate Fuel Capsule

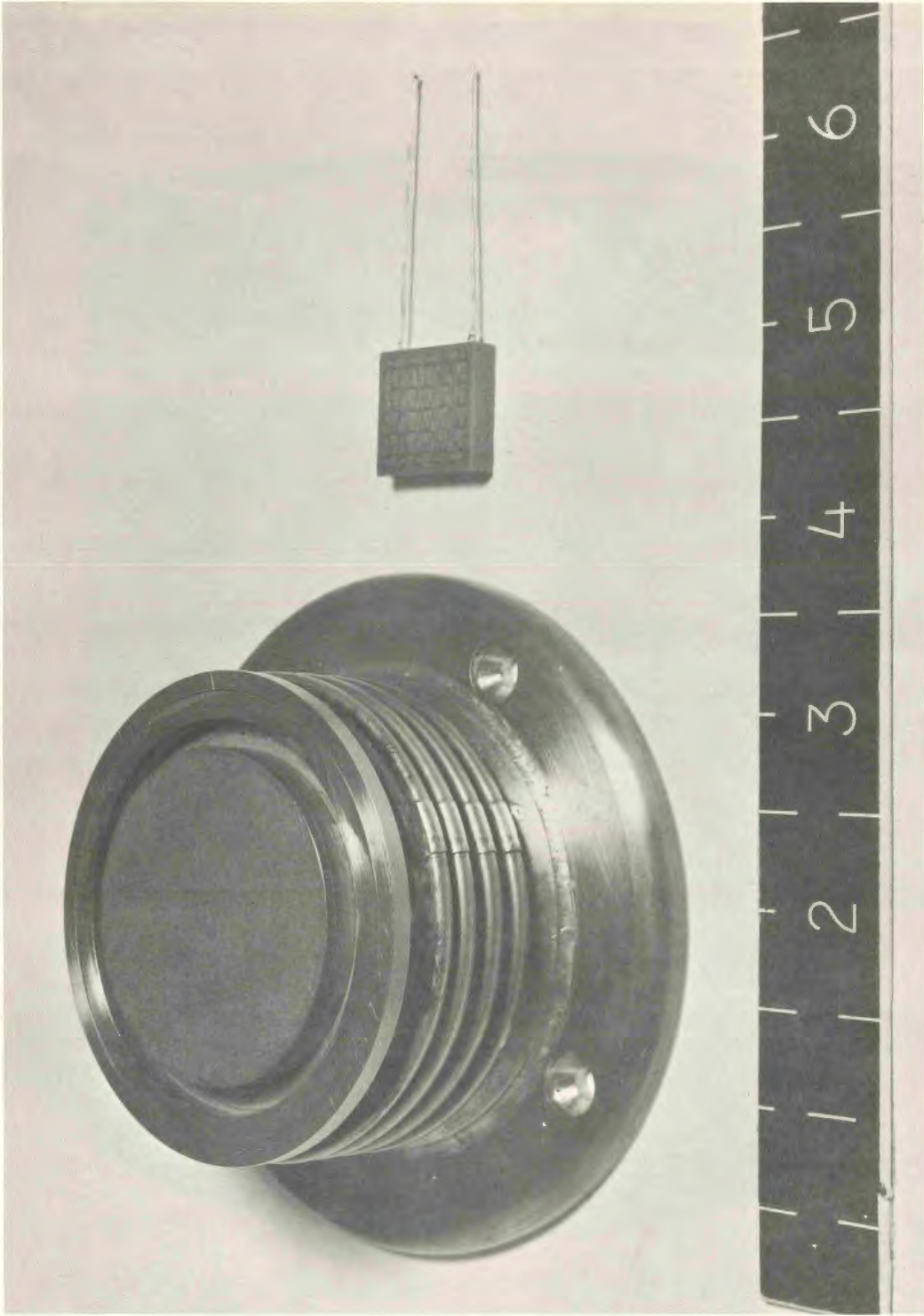

Figure 10. URIPS Converter Assembly and TH1010 Thermoelectric Module

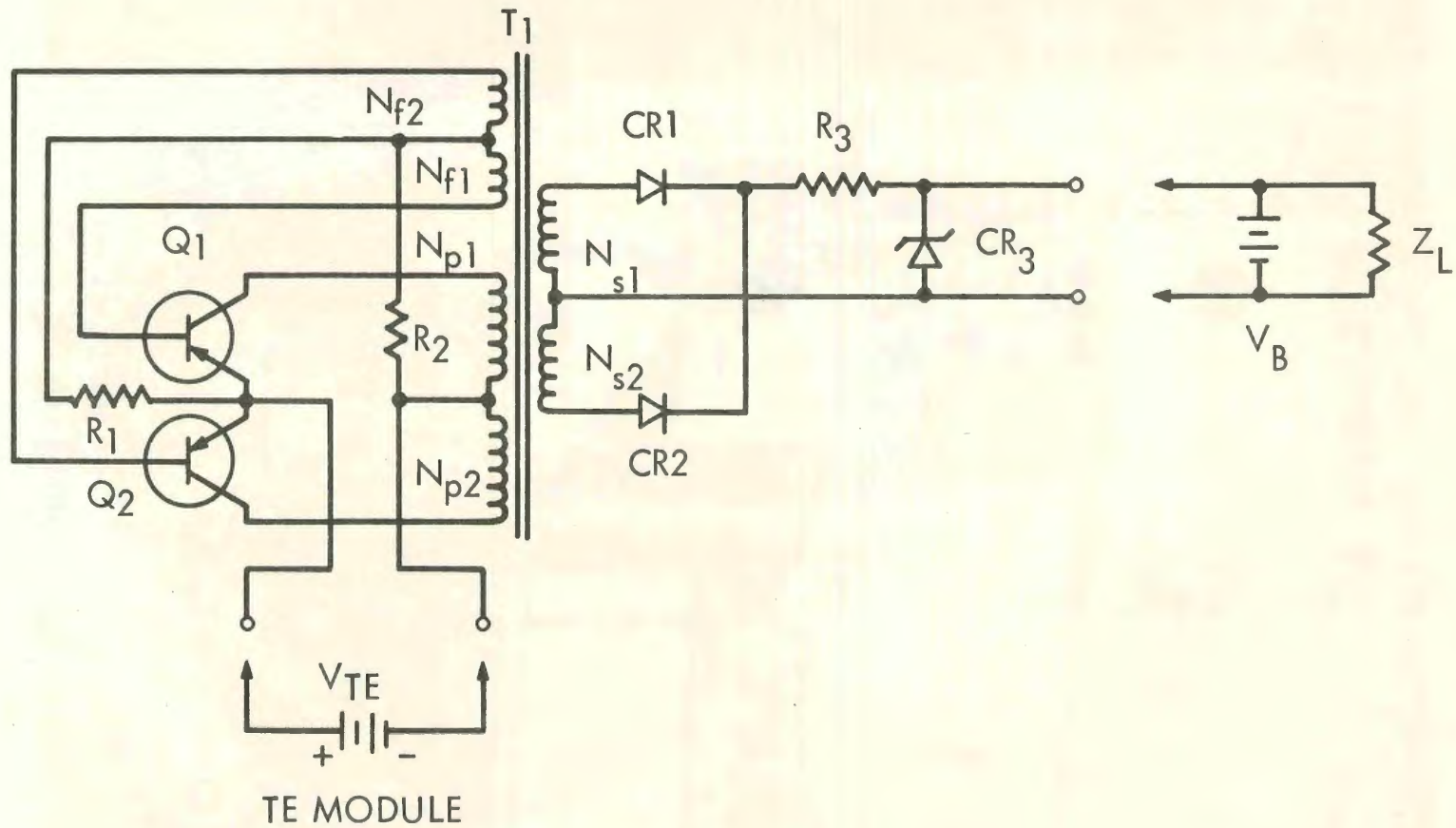

Figure 11. Power Conditioning Circuitry



Figure 12. Aerojet Undersea Radioisotope Power Supply (URIPS-P1-1001)