

# Autonomous Satellite Recovery Vehicle



Devonte Grantham, Francisco Pastrana, Shane Williams, William Lewis, Joshua Moffett, Jessy Law, & Kyle Ouellette

Embry-Riddle Aeronautical University  
600 S. Clyde Morris Blvd Daytona Beach, FL  
32114

Advisor: Janet Marnane,  
Marnanej@erau.edu

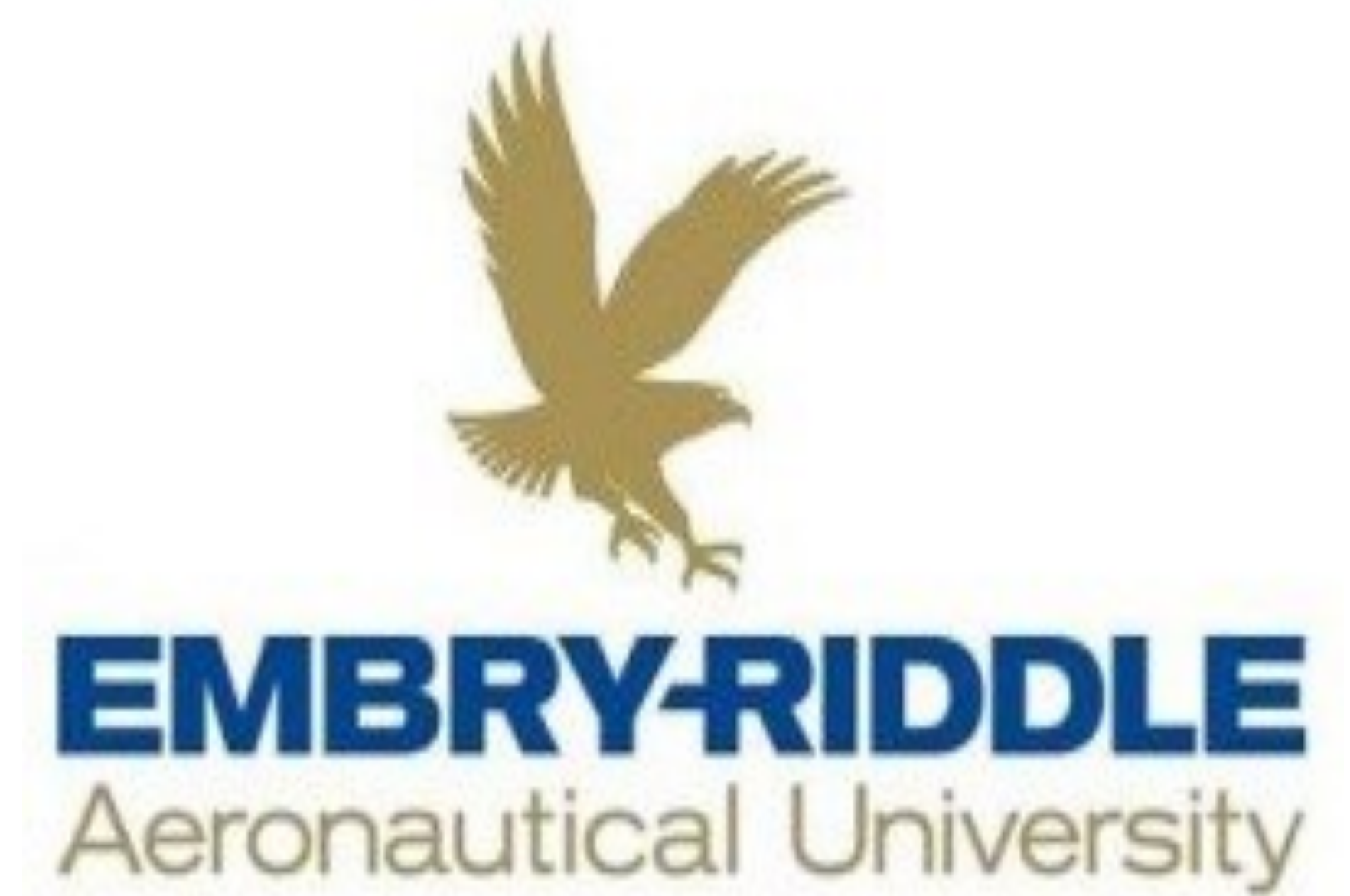

## Abstract

In collaboration with ERFSEDS, we plan to send a small satellite attached to a quad-copter as the payload for ERFSEDS rocket, which is projected to reach an altitude of 10,000 feet. The quad-copters objective will be to collect atmospheric data as it descends. While descending, the data gathered will help us to understand UAV in high velocity/altitude environments. This project will give us a better understanding of our atmosphere, rocket propulsion systems, and the effect of launch on the payload. Overall, allowing us to gain valuable research, data retrieval, team development and multi-club collaboration experience.

## Introduction

Our plan is to create a new chassis for the quad-copters electronic components and arms. The new chassis will allow the quad-copter to fold its arms inwards to meet the required space constraints. In addition to the critical components of the quad-copter, our design will integrate a number of other data collecting sub-systems currently being used in our weather balloon project. These sensors will be able to collect pressure, temperature, humidity, wind, and video.

## Components

- Pressure, humidity, temperature, and wind sensors
- Arducopter 2.5 (Compatible w/MissionPlanner)
- Aluminum folding chassis
- Power Distribution Board
- 4,000 mAh Lipo battery (2)
- Radio Telemetry
- GPS w/compass
- 9 Channel receiver & transmitter



## Conclusion

The rationale for our project is to gain more experience collecting and analyzing data using unmanned aerial vehicles, as well as developing a new structure for the vehicle itself. This project will also allow us to increase our research and teamwork skills. We have accessed all of the regulations regarding UAVs and plan to be extremely responsible and safe.

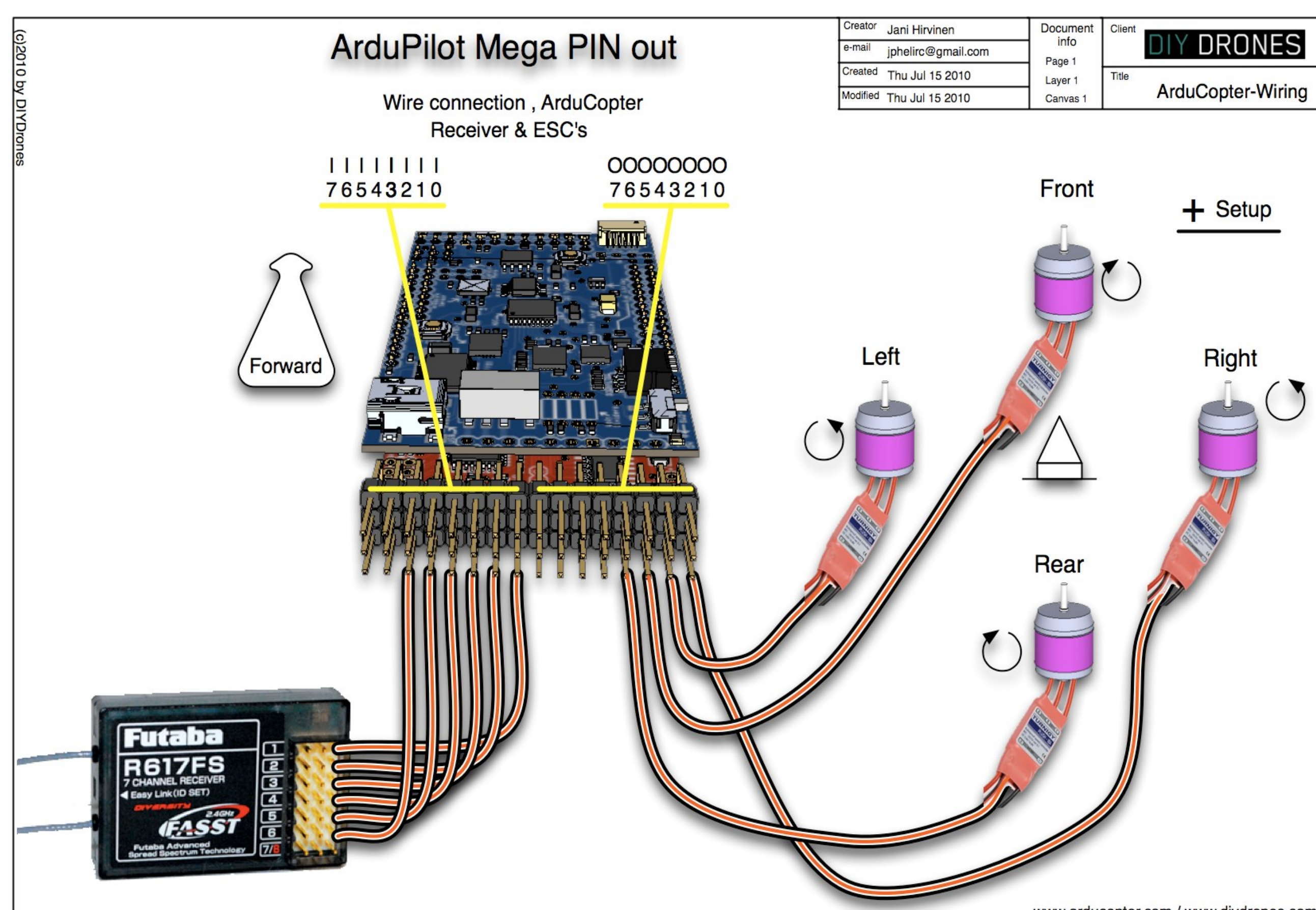

**Acknowledgement to:**  
ERAU, Ignite, SGA, Cubco, &  
Society 4 S.P.A.C.E.

