



The Space Congress® Proceedings

2007 Space Visions Congress - Growing the
Next Generation of Scientists and Engineers

Apr 28th, 8:00 AM

Technical Paper Session II - Cochlear Implant Technology

Adam M. Kissiah
NASA-Kennedy Space Center

Follow this and additional works at: <https://commons.erau.edu/space-congress-proceedings>

Scholarly Commons Citation

Kissiah, Adam M., "Technical Paper Session II - Cochlear Implant Technology" (2007). *The Space Congress® Proceedings*. 7.

<https://commons.erau.edu/space-congress-proceedings/proceedings-2007/april-28-2007/7>

This Event is brought to you for free and open access by the Conferences at Scholarly Commons. It has been accepted for inclusion in The Space Congress® Proceedings by an authorized administrator of Scholarly Commons. For more information, please contact commons@erau.edu.

EMBRY-RIDDLE
Aeronautical University™
SCHOLARLY COMMONS

SPACE VISIONS CONGRESS 2007

TECHNICAL PAPER

SESSION 2

“COCHLEAR IMPLANT TECHNOLOGY”

ADAM M. KISSIAH, JR.

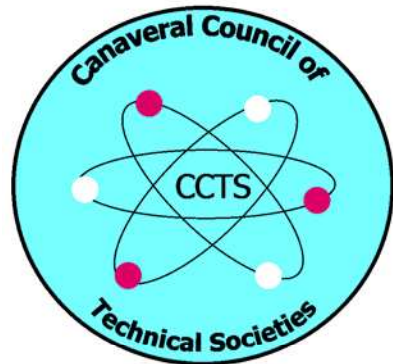

Cochlear Implant Technology

Adam M. Kissiah, Jr.
NASA-Kennedy Space Center, Retired
Institute of Electrical and Electronic Engineers (IEEE)
Life-Senior Member
Southeast Region, Cape Canaveral Section

ADAM321K@aol.com

www.hearagain.org

Abstract

This paper will provide a brief history and description of the Cochlear Implant, including early research, development, experimentation, and implementation of the implant plus the names of many of the most renowned developers and producers.

Second: Adam Kissiah's involvement in hearing research subsequent to the experience of personal hearing loss onset in the Early 1970s, deriving design of basic specifications for simulation of the electronic functioning of the inner ear (Cochlea) in humans.

Kissiah's subsequent award of Patent (4,063,048, December 13, 1977) accomplished through the Kennedy Space Center's Technology Commercialization Program and Patent Counsel, James O. Harrell, Esq.

Third: How our natural hearing mechanism works, and how the Cochlear implant works in the correction of hearing loss.

Fourth: Information regarding implant availability including manufacturers, costs, clinics, surgical aspects, and post-operative activation (therapy) considerations.

Fifth: Sources for additional information.

1. Introduction

It is the desire of this paper to provide you with some information that you will find interesting, and will perhaps answer some questions you may have about hearing in general and the cochlear implant specifically. I would be especially delighted if you learn something that could make a beneficial change in your life, or in the life of a family member or a friend.

The cochlear implant has emerged over the last twenty five years, and especially in the last five years, as a most welcome instrument in life enhancement for many previously deaf and hard-of-hearing persons. It

has done so by providing a means of hearing for the first time for many persons, and by restoring hearing from years past for many others; yet it remains a controversial subject for many, both in the deaf community, and to hearing persons as well.

2. History of the Cochlear Implant

The idea for artificial or electronic correction of hearing loss was first publicized in 1957 when the French team of Djourno and Eyries implanted a patient with a single electrode into the middle ear cavity near the auditory (8th cranial) nerve, and were able to transmit perceivable "noise" to the patient. This was very significant in that the patient was not harmed by the procedure and some sensation was transmitted to him, which in turn encouraged further experimentation and cochlear implant research.

Beginning in the nineteen sixties, and enduring to this day, the most noted and recognized pioneer in basic hearing stimulation research in the USA is Dr. Wm. F. House of the House Ear Institute (HEI), located in Sylmar (Los Angeles), CA. (Cochlear Implants, My Perspective, Wm F. House, M.D.)

Dr. House began experimental implantation of electrodes in humans in the early sixties. By 1969 he had inserted single and multi-electrode implants into several patients, and in 1971, he implanted his first "permanent" single-wire system. Dr House implanted a more advanced system in a patient in 1979. Also in the 1970-1982 time period, HEI, in partnership with Minnesota Mining and Manufacturing (3M) Company, implanted five patients through a clinical trial project. In the 1990s Dr. House and HEI also participated in development of the ALL-HEAR single-electrode system. HEI has recently gained encouraging results in experiments with brain-stem implants where the acoustic nerve (eighth cranial) is inoperative. Also, good results have been obtained in *hybrid* implants, in

which patients with good low-frequency hearing sensitivity, but extremely poor high-frequency response, can benefit.

Dr. House and the House Ear Institute (HEI) are the forerunners of the current Advanced Bionics Corporation, one of the three major providers of cochlear implants today.

The second person or group of note is the well-known and highly praised Dr. Graeme Clarke of Sydney, and the University of Melbourne, Australia, forerunners of Cochlear Americas, Ltd. They are the second (of three) major manufacturers.

Dr. Clark and colleagues also began their research program in the 1960s. He was highly supported by the Australian government, and his program was on par with Dr. William House and the USA research programs. In 1977, he published the results of a multi-electrode implant. Another report in 1979 published by the Australian team described a multi-channel device that would eventually lead to their most popular implant, namely the Cochlear Americas' "Nucleus". Other well-known researchers during the time period beginning in the late seventies and early eighties included Dr. Blair Simmons and Dr. Robert White of Stanford University, who produced significant results in Cochlear implant development in their Stimuliss program and their Bioear program in association with Biostim, Inc. There was also Drs. Michelson, Mersench and Schindler of the University of San Francisco Medical Center, Dr. Claude Henri-Chouard of France, Dr. Donald Eddington of the University of Utah, principle researcher in development of the Inneraid implant, and Dr. Thomas Balkany, at the Denver Ear Institute, and later at the University of Miami and Jackson Memorial Hospital.

It is noted that these early implants did not (yet) employ to the fullest extent the principles of synthesis of the audio spectrum and application of the place-specific-audio components directly to specific locations of the acoustic nerve, as specified in patent 4,063,048 (see below). As a result the patients sensed primarily background noises, and did not enjoy the full potential of the intelligence and communication factor of the spoken word, except as an aid to lip-reading. This new life-sense did, however, achieve the highly desirable quality of enabling deaf persons to emerge from the isolation of silence and enter the world of sound, which significantly improved their "attachment" to society.

Still other notables of this era included Dr. Blake Wilson, Charles Finley and others at the Research Triangle Institute in Raleigh-Durham, NC, who pioneered in forming the **Med-El Corporation**, maker

of the Pulsar CI-100. Med-El, Ltd is head-quartered in Innsbruck, Austria.

Important research was also conducted (by others) at the University of Utah, the University of Oregon, and still others at the University of Toronto.

Adam Kissiah of NASA-Kennedy Space Center (KSC) in Florida was also involved in his personal prosthesis design research during this time period. While employed with NASA-KSC, Kissiah, because of personal hearing problems, involved himself in a study of the general aspects of hearing. As a result, a design for the electronic simulation of the operation of the human cochlea (inner ear) was devised. U.S. Patent was applied for through the Kennedy Space Center Technology Commercialization Program, James O. Harrell, Patent Counsel. Patent 4,063,048 was granted (issued) December 13, 1977, Reissue 31,031 on September 14, 1982. This was the first U.S. (world-wide) Patent describing the basic design of the cochlear implant. It was considered a breakthrough in design for providing artificial stimulation of the cochlea, providing realistic correction for hearing loss in humans.

More than 50 subsequent patent application referred to 4,063,048 as prior art in that field. This technology has therefore been available, and utilized since December, 1977. It is noteworthy and appropriate that member of the technical community should contribute the electronics design of the cochlear implant, and it is equally appropriate that the medical community should develop and produce the implant for the public.

Below is a copy of the original (first page) Patent (4,063,048) which provides the basic specifications for all cochlear implants:

[11] 4,063,048

[45] Dec. 13, 1977

United States Patent [19]

Kissiah, Jr.

[54] **IMPLANTABLE ELECTRONIC HEARING AID**

[76] **Inventor:** Adam M. Kissiah, Jr., 155 E. Brandy Lane, Merritt Island, Fla. 32952

[21] **Appl. No.:** 778,193

[22] **Filed:** Mar. 16, 1977

[51] **Int. Cl.:** H04R 25/00

[52] **U.S. Cl.:** 179/107 R; 128/1 R

[58] **Field of Search:** 128/1 R; 179/107 R, 179/107 BC, 107 E, 107 FD

Primary Examiner—George G. Stellar
Attorney, Agent, or Firm—James O. Harrell; John R. Manning

[57] ABSTRACT

An electronic hearing aid device for enabling persons having loss of hearing due to a nonfunctioning inner ear (Cochlea), but have a responsive auditory (acoustic, or eighth cranial) nerve, to hear by way of an electronic device including a microphone for receiving audio signals connected to an amplifier for converting the audio signal into an analog voltage signal. The analog voltage signal is filtered by a series of filter networks which separate the analog voltage signal into a plurality of frequency component signals each having a predetermined frequency range within the audio spectrum. The component analog voltage signals are then converted into digital pulse signals having the same frequency as the component voltage signal which are fed to the auditory nerve by way of implanted platinum (or other) wires wherein the digital pulse signals more accurately simulate the natural sound signals transmitted to the brain for interpretation.

Cochlear Implant Design – Patent 4,063,048 (12/1977)

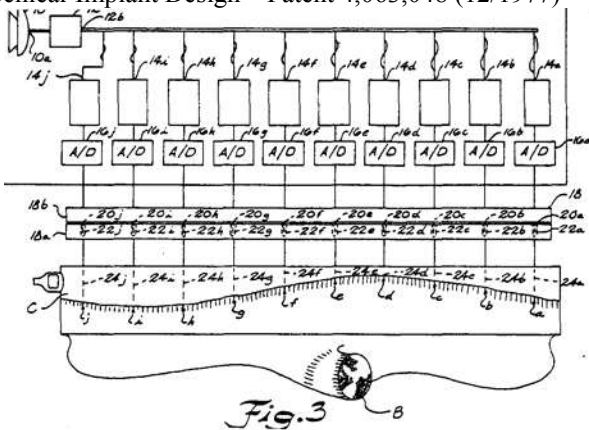

It is noted that the *basic* designs of Implants of today are unchanged from Patent 4,063,048 (Dec 13, 1977) except for ever evolving physical and performance improvements through modern developments in miniaturization, micro-circuitry, and both hardware and software applications designs. For comparison with modern design refer to the design of Dr. Phillip C. Loizou, Professor in the Engineering Department of The University of Texas at Dallas. See www.utdallas.edu/~loizou/cimplants/tutorial/loifig4.gif

3. The National Institutes of Health’s Role in Cochlear Ear Implant Development

In the late seventies and early eighties and beyond, as a result of research by the leaders above, and technology breakthroughs (the Patent described), the National Institutes of Health (NIH) increased significantly its output of research money to university and other research centers. The NIH provided funding and guidance under the direction of Dr. F. Terry Hambrecht, director of the National Institutes for Neurological Diseases and Stroke (NINDS), and they also provided a central focus point for the cochlear implant’s development and production process.

Contributions by private investors and donors also added significant funds in promoting a high level of research in all sectors of society in development of the cochlear implant.

The above shows clearly that the National Institutes of Health and many persons and institutions contributed significantly to the development and production of the cochlear implant.

4. The (Natural) Hearing Mechanism and How It Works

The human hearing mechanism is a bio-engineering master-piece. The external ear helps direct sound waves, or acoustic energy, to the eardrum, causing it to vibrate. These vibrations are transmitted through the ossicular chain of bones (malleus, incus, and stapes), through a small oval-shaped window into the inner ear (cochlea).

Below: The Cochlear (Basilar) Membrane: From IEEE Engineering and Medicine and Biology, Volume 6, Number 2, June, 1987 – Article Entitled “Coding of Acoustic Signals on the Auditory Nerve”, by G. Daniel Geisler, the University of Wisconsin-Madison.

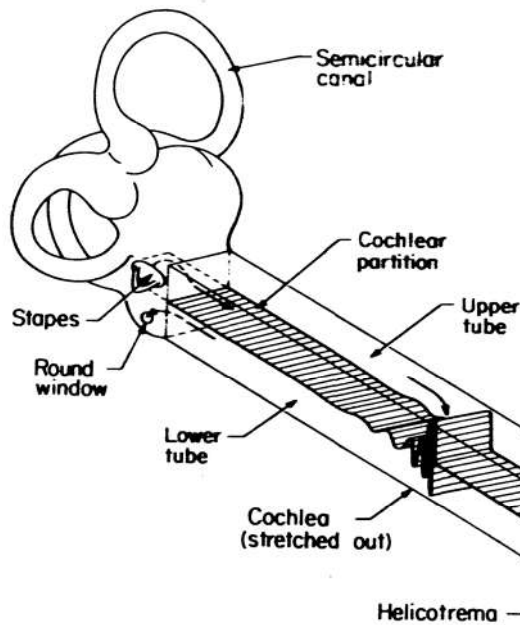

Figure 1: Schematic sketch of the cochlea, stretched out from its actual spiral form, catching a mid-frequency traveling wave at a particular instant. Adapted from Zweig et al. IEEE copyright line (© 1987).

The cochlea is a bony cavity, shaped like a small snail shell, which is divided into two inner sections by a flexible membrane called the basilar, or cochlear, membrane. Vibrations, or sounds, entering the cochlea create waves, like sonar waves, in the fluid-filled cavity within the cochlea. This wave motion causes resonating vibrations at specific locations on the cochlear (*basilar*) membrane in accordance with the stimulating frequency(s). In normal hearing, some 15,000 to 20,000+ delicate nerve endings, called hair cells, are attached on one end to the flexible cochlear membrane and the other to the acoustic (8th cranial) nerve.

The cochlear membrane extends the full internal length of the Cochlea. These mechano-electric nerves (hair cells that fire when agitated) generate electrical impulses in intelligent wave patterns in response to audio stimuli (waves), which are in turn transmitted to the hearing center of the brain by way of the auditory nerve. These wave patterns are recognized as “sound” which can contain “intelligence” which we label as voice, music, and many other classifications of audio information.

In many deaf and hard of hearing persons these vital and delicate nerve endings that provide the link between the vibrating cochlear membrane and the acoustic nerve are missing. Reasons for the missing nerves range from physical trauma, inherited

deficiencies, disease, ototoxic drugs, loud noises, and other causes.

There are other *physical* abnormalities that result in “conductive” hearing loss in humans, such as otosclerosis (calcification), infection, scar tissue, fluid and wax build-up, etc. These losses are usually treatable locally by ear-nose and throat doctors.

As stated above, Patent 4,063,048 represents the first patented description of the basic specifications for the functioning of the human cochlea, and a means for correction for hearing loss from loss of “hair cells”.

Because all implants share a common basic design, there is no clear-cut consensus that any one of the implants is superior to the others. All cochlear implant devices, however, display a wide range of enhancements, including physical designs and performance characteristics.

Shown below is the Biostim Inc Implantable Hearing Stimulator I, (1980[©])

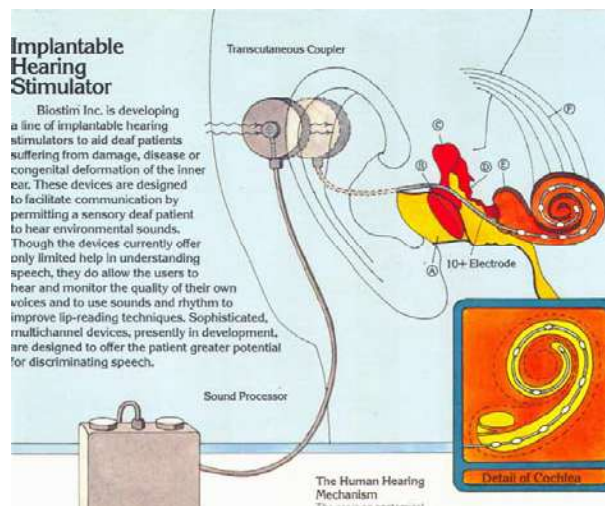

Above is a pictorial display of an implantable hearing stimulator designed by Biostim, Inc., a biomedical instrumentation development company in 1980. Biostim, Inc., Lloyd A. Ferreira, President and Chief Executive Officer, was headquartered in Princeton, NJ, and working through contractual licensing agreement from Adam Kissiah, Jr., inventor of the design. In 1982 Biostim, Inc. through its subsidiary, Bioear, Inc. undertook a research program of the same name (Bioear) under an FDA approved experimental permit, an Investigational Device Exemption (IDE) in association with Stanford University, Dr. F. Blair Simmons, principal investigator and Dr. Robert White, Chairman of the Department of Electrical Engineering.

Biostim, Inc. Implantable Hearing Stimulator (1980^{cs})

Multichannel System

Biostim is also developing a system invented by Adam Kissiah, an otological patient, and for over 15 years a NASA engineer at the Kennedy Space Center. This device also involves two parts, an external sound processor, approximately the size of a deck of cards, and an implanted 10-electrode stimulating system. A microphone and an audio amplifier are used to amplify the analog electrical signal which is separated into 10 filtered audio frequency channels and converted into uniphasic pulse-signals. The pulse-signals resulting from this process are fed through the skin to the implanted stimulating electrodes. This system, designed to offer sound discrimination as well as improved speech intelligibility, connects each channel directly to the portion of the auditory nerve that is known to be sensitive to a specific frequency band. Thus, the electrical stimulations bypass the outer and middle ear, and are transmitted, via the auditory nerve system, directly to the brain for interpretation as sound.

In addition to these two types of auditory implants, Biostim is developing a model which incorporates the principle of applying pulses derived from raw audio found in Kissiah's design with the sophistication of the Multiplexed, Multichannel System.

Sound waves are picked up by a tiny microphone housed in a headpiece that is worn at ear level. The microphone output is routed to a processor, which synthesizes and rectifies the sounds into audio "spectral bands" with the aid of a number of band-pass filters. Envelope detectors convert the spectral bands into digital (pulsatile) signals.

The digital impulses are shaped and controlled in amplitude, pulse-widths and application rates, etc. and routed to the primary windings of an electromagnetic transmitter. In some models, the microphone and transmitter are in the same piece, and in other models the microphone is in a behind-the-ear piece that looks like a standard hearing aid.

The transmitter, which is held by a magnet on the side of the head behind the ear, sends the pulsatile signals via magnetic induction, through the skin to the cochlea via *receiver* electrodes that have been inserted into the cochlea. These electrodes provide direct stimulation to the brain via the auditory nerve, sending impulses in intelligent wave patterns where they are interpreted as sounds.

In recent years extensive (and very competitive) experimentation has been performed by all manufacturers in an effort to exploit all possible methods of synthesizing and applying the audio spectrum of electrical stimuli to the acoustic nerve, in a continual effort to achieve the maximum possible intelligence, fidelity and clarity of audio information. The preponderance of current usage is the outgrowth of the multi-channel design described in Patent 4063048 (Dec, 1977), although many experiments by the House Ear Institute in the single channel implant have achieved success in specialized applications.

Many new strategies for increasing the (effective) number of audio channels being applied to the acoustic nerve have been developed, thereby providing greater fidelity in a true reproduction of original audio inputs. These capabilities have resulted in dramatically increased so-called "open-set" comprehension scores for words and sentences in clinical trials and in true public environmental situations. All manufacturers make the greatest effort to ensure "backwards compatibility" of new applications, in order to make certain that new developments and modifications to implants are made available for upgrade to patients with older models of implants. This policy enables most cochlear implant users to be able to take advantage of the latest in implant technology. In some cases, older implants are replaced with new ones in order to receive these upgrades. Such terminology used by MED-EL as Continuous Interleaved Sampling (CIS), Virtual Channel Interleaved Sampling (VCIS), Compressed Analog (CA), are examples of the

Multichannel System

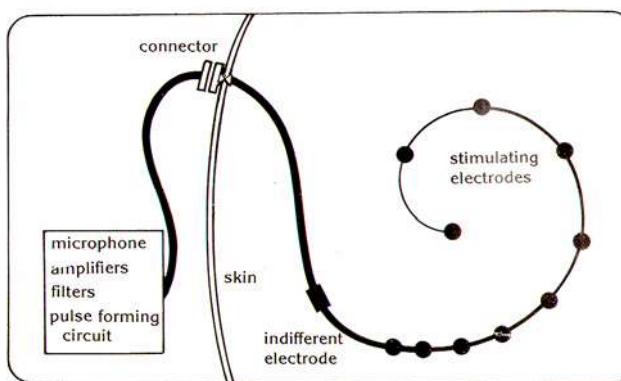

5. How the Cochlear Implant Works

somewhat descriptive terminology of the several proprietary methods of the application of stimuli, both software and hardware oriented. These innovative methods have resulted in an accompanying dramatic increase in the effective number of channels of applied stimulus, and thus the intelligence conveyed.

6. Selection Process for Candidates for the Cochlear Implant.

Infants and small children are placed in a special category. More on this will be discussed in 6.1.

The early childhood and adult candidate for an implant may obtain referral by a family physician or ear-nose-and throat (ENT) physician to a known implanting physician, clinic or implant team; or the patient may make direct phone contact with an implant team/clinic (information provided herein). Next, an appointment or interview will be scheduled.

Candidates will be scheduled for an examination by a medical doctor and an audiologist for a detailed hearing examination. A detailed psychological profile will also be established. Some (not all) of the basic qualifications are: Severe to profound hearing loss in both ears (70 db or greater); post-lingual onset of severe to profound hearing loss in adults; limited benefit from hearing aids; desire to improve hearing; realistic expectations; no medical contraindications.

At this point, approval to receive an implant will be recommended or denied. If approved the candidate will be advised of costs, and your financial status will be determined. You will be advised to seek approval of insurance coverage before advancing further into the program.

It is important that the candidate make certain to inquire into the complete insurance coverage of all costs, including pre-surgical physicals, hearing examinations, psychological profiles, the surgery itself, plus the complete processor and all its parts and accessories. Make certain that the extensive post-surgical audiological activation, programming (mapping) and speech therapy are included. Prior written approval of insurance coverage before surgery will avoid costly surprises.

Costs of the implant are thirty to sixty thousand dollars in the US but are gradually being reduced because of more efficient procedures and routines, insurance company pressures, and some competition from overseas.

If approved, surgery will be scheduled and completed. Follow-up rehabilitation, plus extensive audiological training and therapy will be performed.

The success rate for surgeries and electronics operability is 99 percent-plus. Success in

understanding of the spoken word, and general usability of the implant is dependent on many factors, including the length of time of deafness, age, psychological factors, effort made to learn, and so on. Instantaneous achievement of full benefits of hearing and understanding is *not* to be expected.

The post-surgical audio programming is highly important. In many cases, maximum hearing benefit from the implant cannot be achieved without this formal and extensive programming (mapping), therapy and training. It can literally make the difference between success and failure to achieve maximum benefits from the implant.

6.1 Early intervention

Children and babies as young as 1 year old can receive cochlear implants. The U.S. Department of education makes a hearing loss brochure available entitled "Opening Doors: Technology and Communications Options for Children with Hearing Loss."

The brochure is distributed by each state's early intervention program and is on the U.S. Department of Education's website at: www.ed.gov/about/offices/list/oseers/products/opening_doors/. The brochure provides information to help parents make important decisions about their children's hearing health.

Implanting of senior citizens - Dr. John Niparko of Johns-Hopkins University, in the Department of Otolaryngology, Head and Neck Surgery in Baltimore reported that in 2005, individuals over the age of 65 accounted for 24% of cochlear implant surgeries (HLA Convention, 2006). Medicare provides insurance coverage for patients who qualify. Patients in their seventies, eighties, and even nineties have been successfully implanted.

7. Some Commercial Implant Providers

As stated above, because all implants share a common basic design, there is no clear-cut consensus that any one of the implants is superior to the others. Users of all three devices display a wide range of enhancements, physical designs and performance characteristics.

Advanced Bionics Inc. is a subsidiary of Boston Scientific, Inc., a company that is also a major manufacturer of heart pacemakers. Advanced Bionics is an outgrowth of Dr. William F. House' Hearing Research Center, now named the House Ear Institute (HEI). They were the makers of the older "Clarion" model implant, and they are also known as the maker of the "Bionic Ear" Hi-resolution (Hi-Res) system.

Their latest models include the Hi-Res 90k implant and the Hi-Res "Auria", with web sites at www.cochlearimplant.com, and www.bionicear.com. Their offices are located in Sylmar, CA and France.

The leader in the total number of Cochlear Implants made world-wide is the Australian Cochlear Americas, Ltd., headquartered in Sydney, Australia and maker of the Nucleus Freedom implant, with over 80,000 persons implanted. Their web-site is www.cochlearamericas.com.

Med-El, Ltd.'s headquarters are in Innsbruck, Austria, with primary U.S. Offices in Raleigh-Durham, NC. Med-El makes the Combi 40+ implant and the New Pulsar CI-100 which includes their latest and most improved Med-El technology. Med-El's website is www.medel.com.

MXM Laboratories – Digisonic, Inc.
www.mxmlab.com

AllHear, Inc. Post Office Box 330
Aurora, Oregon 97002
(503) 266-6730 (voice)
(503) 266-6418 (fax)

AllHear@AllHear.com

Since all of these devices have a similar range of performances, other criteria are considered when choosing a cochlear implant, such as usability of external components, cosmetic factors, battery life-whether replaceable or rechargeable, versatility of internal and external components, customer service from the manufacturer, the implanting physician, audiologist and the quality of association (familiarity) of personnel with a particular device, and other physical concerns. Only you can decide which is best for you.

8. Some Internet Information Sources

Deafness Research Foundation www.drf.org is a

8201 Greensboro Drive, Suite
8201 McLean, VA 22102
Phone (703) 610-9025

Gallaudet University www.gallaudet.edu is the world's only university geared specifically to the needs of the deaf. The site includes links to other deaf schools in the United States.

The National Association of the Deaf (NAD) <http://www.nad.org/>. The NAD advocates the civil rights of the deaf and hard-of-hearing in a variety of areas including education, employment, health care, social services and telecommunications.

614 Thayer Avenue
Silver Spring, MD 20910-4500
Phone (301) 587-1791

The National Theater of the Deaf (NTD) <http://www.NTD.org/> offers information about upcoming performances, workshops and classroom visits.

Silent News.org <http://www.silentnews.org> is a magazine Website that offers deaf news, message boards, and classifieds.

9. Additional Sources for Information

Alexander Graham Bell Association for the Deaf and Hard of Hearing (A.G. Bell) 3417 Volta Place, NW
Washington, DC 20007

Voice: (800) Hear-Kid or (202) 337-5221

TTY: (202) 337-5221, Fax (202) 337-8314

Email: info@agbell.org

E-mail: info@agbell.org

Internet: www.agbell.org

The American Academy of Otolaryngology-Head and Neck Surgery (AAO-HNS)

One Prince Street
Alexandria, VA 22314

Voice: (703) 836-4444

TTY: (703) 519-1585

FAX: (703) 683-5100

E-mail: webmaster@entnet.org

Internet: www.entnet.org

The Cochlear Implant Association, Inc.
5335 Wisconsin Avenue NW, Suite 440
Washington, DC 20015-2034

Voice: (202) 895-2781

TTY: (202) 895-2781

FAX: (202) 895-2782

E-mail webmaster@entnet.org

National Association of the Deaf
614 Thayer Avenue

Silver Spring, MD 20910-4500

Phone (301) 587-1791

<http://www.nad.org>

E-mail: nadinfo@nad.org

House Ear Institute (HEI)

2100 West Third Street, Fifth Floor
Los Angeles, CA 90057

Voice: (213) 483-4431

TTY: (213) 484-2642

FAX: (213) 483-8789

E-mail: webmaster@hei.org

Internet: www.hei.org

For additional information exchange and interaction with other implant patients, see the Internet:

<http://www.groups.yahoo.com/group/ci/>

Also search Google keyword "Cochlear Implant", or see website www.hearagain.org

10. Closing Statements

It is recommended that anyone who has a question about his or her own hearing or the hearing of a loved one or someone you know, that you or that person should contact qualified and practicing professionals, or hearing clinic to be tested and screened. The importance of being properly tested cannot be stressed enough, especially where infants and small children are concerned. They should be tested as early in life as possible. Elderly people should not automatically assume that they are too old, or that they could not qualify. Medicare pays for implants to qualified patients and it costs very little to ask questions.

Patients in their sixties, seventies, eighties, and even ninety years of age have been successfully provided with cochlear implants.

Each person is obligated to himself and his family to ask questions and obtain information needed to be

fully informed regarding his hearing and this vital human sensory capability.

11. References

The House Ear Institute Cochlear Implant System for Children, Karen Berliner, PhD, Laurie S. Eisenberg, MA, 1985

House Ear Institute – About the Institute (Oct 2004)

The Hearing Review Implants for Children Mark 25th Anniversary (Strom – 2005)

Cochlear Implants: My Perspective, Wm F. House, DDS, M.D.

Hearing Instruments, Volumn 36, 11/1985

Science Magazine, the Bulletin, 12/1979

The "Bioear" Cochlear Implant System, Lloyd A. Ferreira, 1985

Bionic Ear Brings New Hope, Rees, Science Magazine, (1979)

Ear Surgery 'First' Lessens Deafness, Denver Post. Pankratz, (9/1979) Wm F. House - Cochlear Implant

Adam M. Kissiah, Jr. – March 15, 2007

Display 1

Space Visions Congress April 26-28, 2007

Presented by: The Canaveral Council of Technical Societies (CCTS)

Lecture: Cochlear Implant Technology

Author: Adam M. Kissiah, Jr. – NASA-KSC (Ret)

IEEE – Southeast Region – Canaveral Section

April 28, 2007

**The University of Central Florida, Brevard Community College, and the Florida Solar Energy Cntr, Cocoa, FL
Dr. Nelkanth Dhere, Director**

DISPLAY 2

THIS LECTURE WILL COVER THE FOLLOWING TOPICS

–

BRIEF HISTORY OF THE DEVELOPMENT OF THE COCHLEAR IMPLANT AND HOW ADAM KISSIAH'S BACKGROUND RELATES TO THE COCHLEAR IMPLANT INCLUDING PATENT #4,063,048 – REISSUE 31,031

THE NATIONAL INSTITUTES OF HEALTH INVOLVEMENT IN COCHLEAR IMPLANT DEVELOPMENT

PRINCIPLES OF HEARING AND DESCRIPTION OF THE HEARING MECHANISM, INCLUDING THE COCHLEAR IMPLANT

CURRENT PRACTICAL ASPECTS OF THE IMPLANT'S USAGE

SOURCES FOR ADDITIONAL INFORMATION

CLOSING REMARKS

[54] IMPLANTABLE ELECTRONIC HEARING AID

[76] Inventor: Adam M. Kissiah, Jr., 155 E. Brandy Lane, Merritt Island, Fla. 32952

[21] Appl. No.: 778,193

[22] Filed: Mar. 16, 1977

[51] Int. Cl.² H04R 25/00

[52] U.S. Cl. 179/107 R; 128/1 R

[58] Field of Search 128/1 R; 179/107 R, 179/107 BC, 107 E, 107 FD

Primary Examiner—George G. Stellar
Attorney, Agent, or Firm—James O. Harrell; John R. Manning

[57] ABSTRACT

An electronic hearing aid device for enabling persons having loss of hearing due to a nonfunctioning inner ear (Cochlea), but have a responsive auditory (acoustic, or

eighth cranial) nerve, to hear by way of an electronic device including a microphone for receiving audio signals connected to an amplifier for converting the audio signal into an analog voltage signal. The analog voltage signal is filtered by a series of filter networks which separate the analog voltage signal into a plurality of frequency component signals each having a predetermined frequency range within the audio spectrum. The component analog voltage signals are then converted into digital pulse signals having the same frequency as the component voltage signal which are fed to the auditory nerve by way of implanted platinum (or other) wires wherein the digital pulse signals more accurately simulate the natural sound signals transmitted to the brain for interpretation.

6 Claims, 5 Drawing Figures

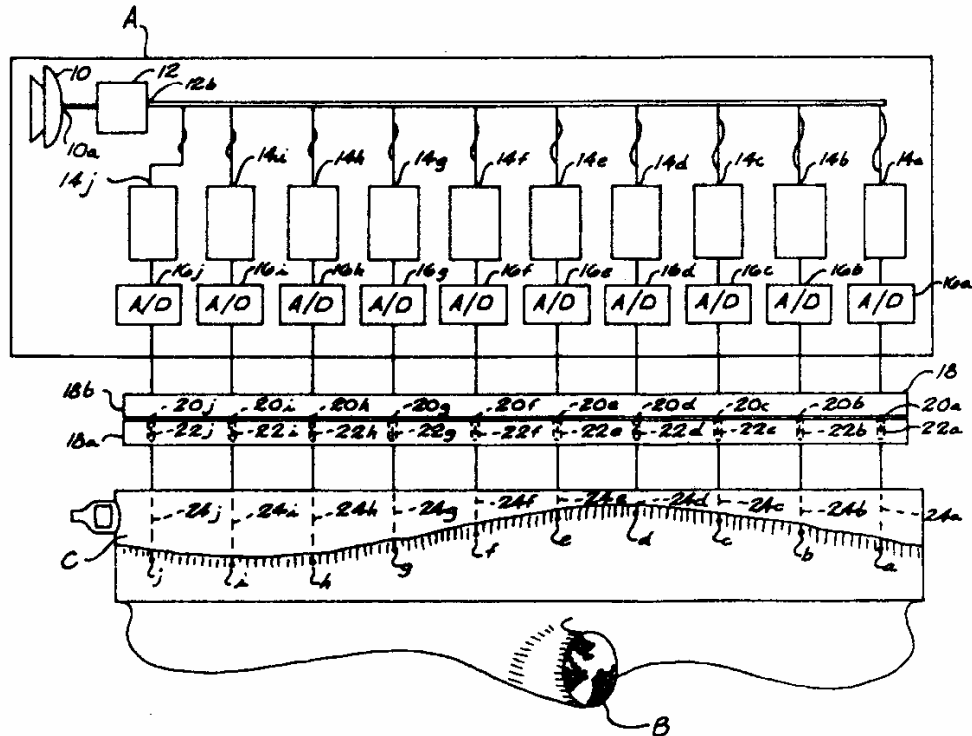

Cochlear (Basilar) Membrane

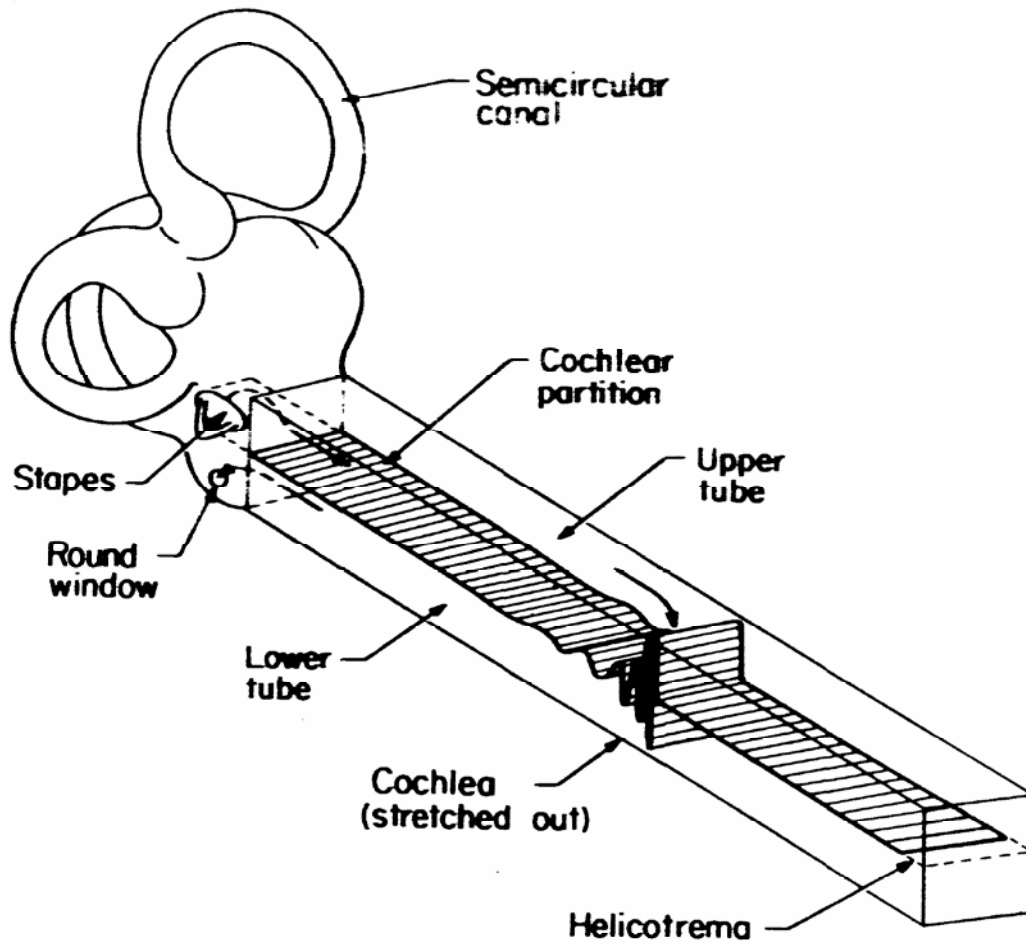

Health

Ijt

CRONS
1055 in the ears from



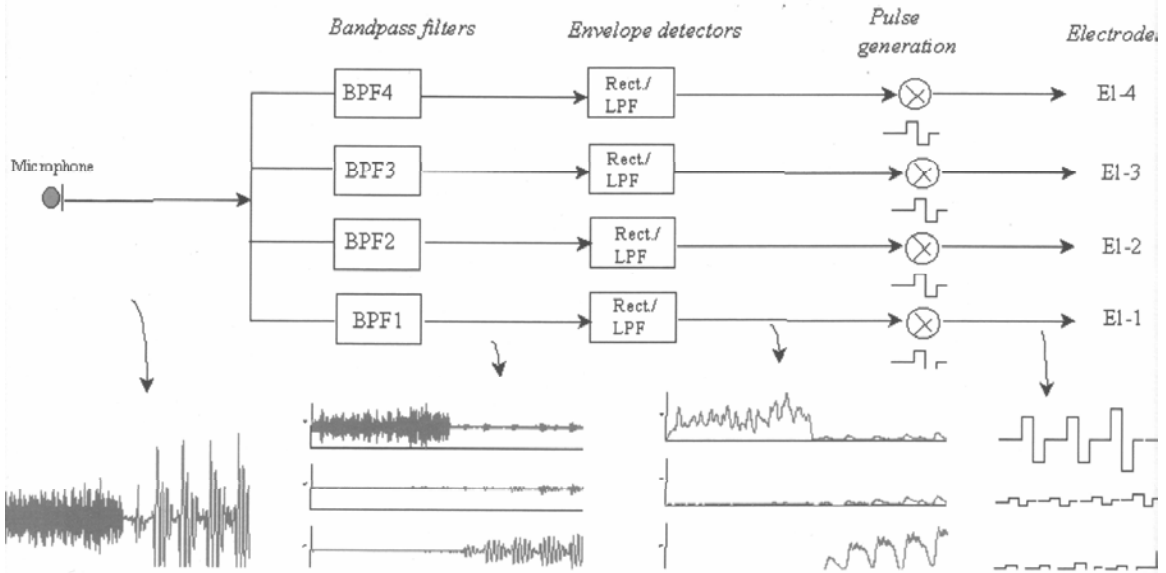
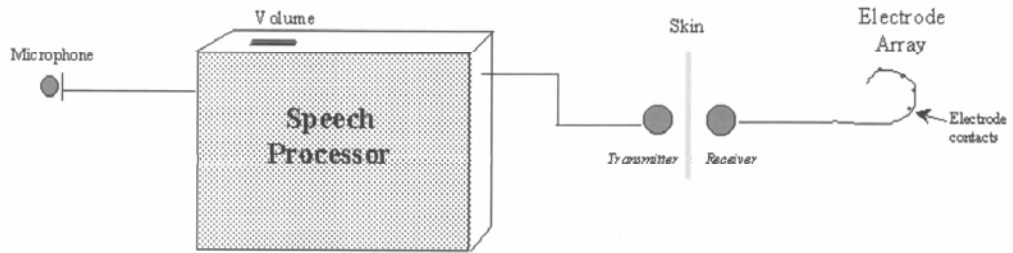

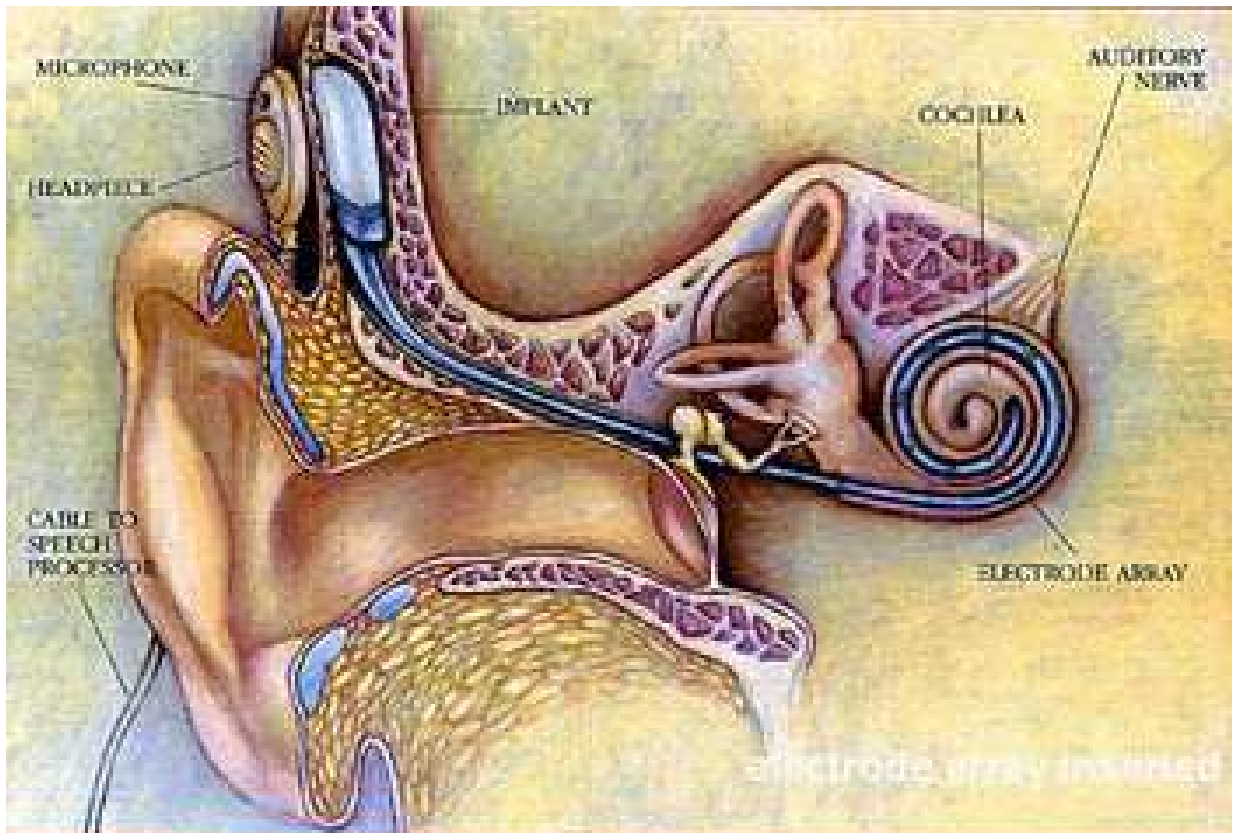

Schematic of cochlear implant; note electrode array inserted into cochlea.

IEEE CHART 5B - MODERN COCHLEAR IMPLANT - AUSTRALIA'S COCHLEAR AMERICAS CORPORATION

Implantable Hearing Stimulator

Biostim Inc. is developing a line of implantable hearing stimulators to aid deaf patients suffering from damage, disease or congenital deformation of the inner ear. These devices are designed to facilitate communication by permitting a sensory deaf patient to hear environmental sounds. Though the devices currently offer only limited help in understanding speech, they do allow the users to hear and monitor the quality of their own voices and to use sounds and rhythm to improve lip-reading techniques. Sophisticated, multichannel devices, presently in development, are designed to offer the patient greater potential for discriminating speech.

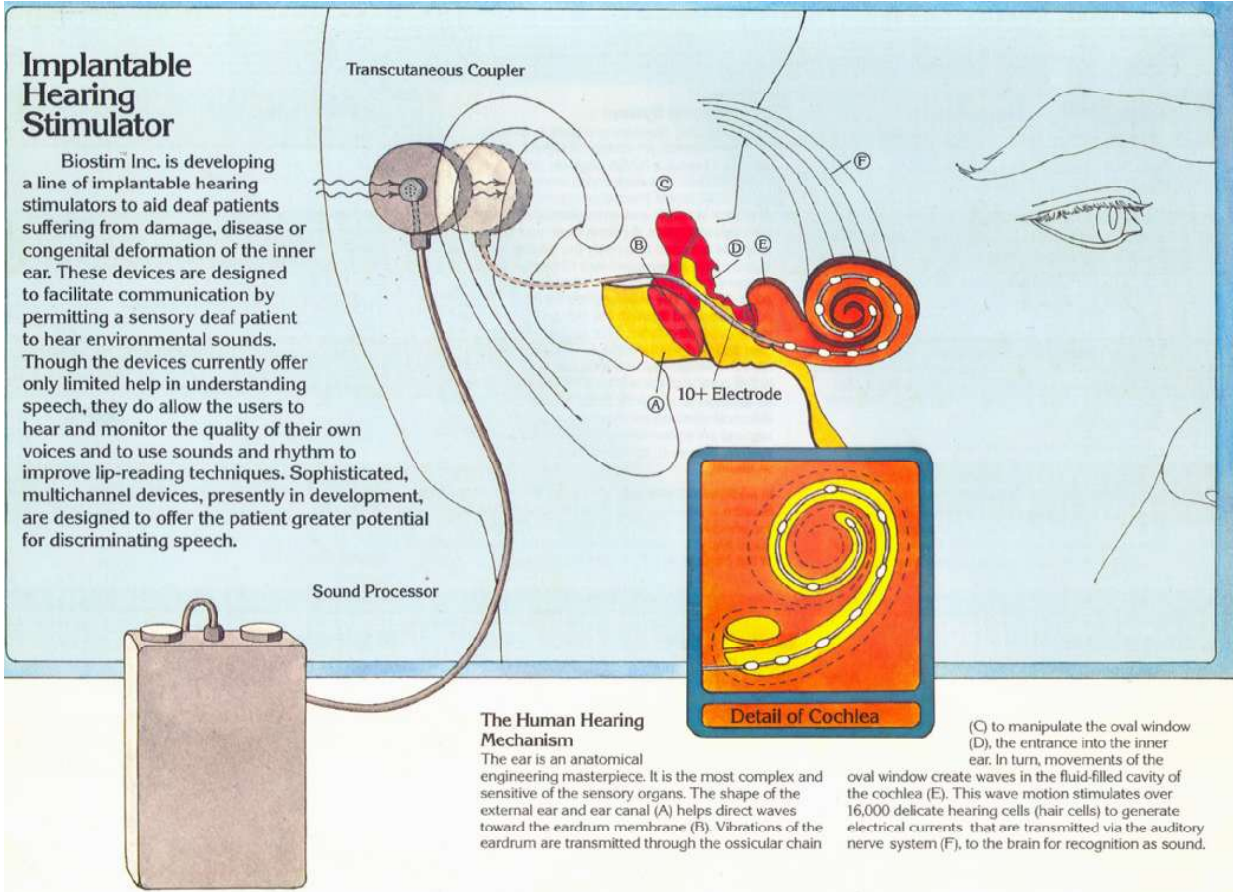

The Human Hearing Mechanism

The ear is an anatomical engineering masterpiece. It is the most complex and sensitive of the sensory organs. The shape of the external ear and ear canal (A) helps direct waves toward the eardrum membrane (B). Vibrations of the eardrum are transmitted through the ossicular chain

(C) to manipulate the oval window (D), the entrance into the inner ear. In turn, movements of the oval window create waves in the fluid-filled cavity of the cochlea (E). This wave motion stimulates over 16,000 delicate hearing cells (hair cells) to generate electrical currents that are transmitted via the auditory nerve system (F), to the brain for recognition as sound.

DISPLAY 10 – COCHLEAR IMPLANT MANUFACTURERS

—

1. THE ADVANCED BIONICS CORPORATION IS AN OUTGROWTH OF DR. WILLIAM F. HOUSE' HEARING RESEARCH CENTER, NOW NAMED THE HOUSE EAR INSTITUTE (HEI).

THE ADVANCED BIONICS CORPORATION WAS ACQUIRED BY BOSTON SCIENTIFIC CORPORATION IN 2004. THEY WERE THE MAKER OF THE EARLIER MODEL "CLARION" MODEL IMPLANT. THEY ARE ALSO PROVIDE THE "BION IC EAR" HI-RESOMUTION (HI-RES) SYSTEM. THEIR LATEST MODELS INCLUDE THE HI-RES 90K IMPLANT AND THE HI-RES "AURIA".

THEIR WEB SITES: www.cochlearimplant.com, www.bionicear.com
OFFICES ARE IN SYLMAR, CA AND FRANCE.

2. ALLHEAR, INC. – IS ANOTHER PRODUCT OF THE HOUSE EAR INSTITUTE. ALLHEAR IS A TRADE NAME FOR A SINGLE ELECTRODE IMPLANT – WHICH WAS PREVIOUSLY A HOUSE / 3M IMPLANT. IT IS NOT YET FDA APPROVED BUT IT MAY HOLD PROMISE IN THE FUTURE.

3. THE AUSTRALIAN COCHLEAR AMERICAS CORPORATION – WITH HEADQUARTERS IN SYDNEY, AUSTRALIA – ARE THE MAKER OF THE NEUCLEUS FREEDOM IMPLANT- KNOWN WORLD-WIDE WITH OVER 80,000 PERSONS IMPLANTED www.cochlearamericas.com/

4. MED-EL CORPORATION – HAS HEADQUARTERS IN INNSBRUCK, AUSTRIA, WITH PRIMARY U.S. OFFICES IN RALEIGH-DURHAM, NC. THEY MAKE THE COMBI 40+ IMPLANT AND THE NEW PULSAR CI-100, WICH HAS THEIR LATEST AND MOST IMPROVED MED-EL TECHNOLOGY. MED-EL'S WEBSITE IS www.medel.com

5. MXM LABORATORIES – DIGISONIC, INC. www.mxmlab.com

HearingLoss.org
Self Help for Hard of Hearing People



[Home](#)

[About Us](#)

[Get Informed](#)

[Get Involved](#)

[Convention](#)

Cochlear Implant Manufacturers

Advanced Bionics - Clarion
www.bionicear.com/

Cochlear Americas - Nucleus
www.cochlearamericas.com/index.asp

MED-EL - Combi 40+
www.medel.com

AllHear - AllHear single channel implant
www.allhear.com

MXM Laboratories - Digisonic
www.mxmlab.com/en/index.htm

Cochlear Implant Resource Links

Acoustical Society of America
asa.aip.org/

Alexander Graham Bell Association for the Deaf
www.agbell.org/

All Our Children
<http://www.allourchildrenwa.org/>

American Academy of Audiology
www.audiology.org/index.php

Association for Research in Otolaryngology
www.aro.org/

Association of Late Deafened Adults
www.alda.org/

Association of Medical Professionals With Hearing Losses
www.amphi.org/

Atlantic Coast Ear Specialists, P.C.
www.earaces.com/

Auditory Neuropathy
auditoryneuropathy.tripod.com/ANindex.html

ADDITIONAL SOURCES FOR INFORMATION - DISPLAY 14

Alexander Graham Bell Association for the Deaf and Hard of Hearing (A.G. Bell)
3417 Volta Place, NW Washington, DC 20007
Voice: (800) HEAR-KID or (202) 337-5220
TTY: (202) 337-5221 FAX: (202) 337-8314

E-mail: info@agbell.org
Internet: www.agbell.org

American Academy of Otolaryngology-Head and Neck Surgery (AAO-HNS)
One Prince Street
Alexandria, VA 22314
Voice: (703) 836-4444
TTY: (703) 519-1585
FAX: (703) 683-5100
E-mail: webmaster@entnet.org
Internet: www.entnet.org

Cochlear Implant Association, Inc. 5335 Wisconsin Avenue NW, Suite 440 Washington,
DC 20015-2034

Voice: (202) 895-2781
TTY: (202) 895-2781
FAX: (202) 895-2782
E-mail: pwms.cici@worldnet.att.net Internet: www.cici.org

House Ear Institute (HEI)
2100 West Third Street, Fifth Floor Los Angeles, CA 90057
Voice: (213) 483-4431
TTY: (213) 484-2642
FAX: (213) 483-8789
E-mail: webmaster@hei.org Internet: www.hei.org

The National Institutes of the Deaf
614 Thayer Avenue
Silver Spring, MD 20910-4500
(301) 587-1791
[Http://www.nad.org](http://www.nad.org)
Email NADinfo@nad.org

The Deafness Research Foundation
8201 Greensboro Drive, Suite 300
McLean, VA 22102
Phone (703) 610-9025