

The Space Congress® Proceedings

2003 (40th) Linking the Past to the Future - A
Celebration of Space

Apr 30th, 1:30 PM - 5:00 PM

Paper Session I-A - Development of a Microscopy Platform for the International Space Station

R. Branly

R. Friedfeld

E. Howard

L. Burgess

J. Ritter

Follow this and additional works at: <https://commons.erau.edu/space-congress-proceedings>

Scholarly Commons Citation

Branly, R.; Friedfeld, R.; Howard, E.; Burgess, L.; and Ritter, J., "Paper Session I-A - Development of a Microscopy Platform for the International Space Station" (2003). *The Space Congress® Proceedings*. 17. <https://commons.erau.edu/space-congress-proceedings/proceedings-2003-40th/april-30-2003/17>

This Event is brought to you for free and open access by the Conferences at Scholarly Commons. It has been accepted for inclusion in The Space Congress® Proceedings by an authorized administrator of Scholarly Commons. For more information, please contact commons@erau.edu.

EMBRY-RIDDLE
Aeronautical University™
SCHOLARLY COMMONS

Development of a Microscopy Platform for the International Space Station

R. Branly, R. Friedfeld, E. Howard, L. Burgess, J. Ritter

Abstract

Microscopy in Zero-Gravity presents numerous challenges from slide and sample preparations to data handling and recording. A team of several Florida schools has established a distributed engineering and science team in conjunction with FSI and FSRI at Kennedy Space Center to address critical issues for an ISS microscopy payload. Flights aboard the KC-135 reduced gravity aircraft have provided engineers, faculty and students with valuable experience applied to the design of sample preparation procedures. Current plans include the development of flight hardware for flight aboard ISS in 2006. The payload includes both a high resolution scanning probe microscopy (SPM) unit and a low resolution light microscopy unit. The development of a Zero-Gravity Microscopy Analysis Platform (ZG-MAP) combines industry effort, in conjunction with academia, to deliver ISS access to both seasoned researchers and students.

Aim of the ZG-MAP Project

The primary aim of the ZG-MAP project is to provide a simple facility available to the entire ISS community for on orbit sample analysis. The payload development team would retain only a maximum of 15% facility usage for community experiments defined in an open forum environment. The concept is fueled by a strong belief that ready access to the space station will foster the interest of the next generation of researchers.

Scientific Motivation

The characterization of the surfaces of materials and the interaction with adhered substances is a key element towards understanding the role of gravity in molecular self assembly and biophysical processes at scales between 10^{-5} m and 10^{-8} m. Upon first examination gravity appears to play no role, but in interactions involving fluid states with a possibility for convection or convective flows the models become non-linear and often chaotic. Areas of study such as protein folding are limited to simple quantitative models due to computational time limitations and the lack of guiding empirical data. Data that would give clues about the interactions of long organic molecules in a scale ranging from 100 base pair DNA strands to small cells would provide critical constraints for quantitative modeling. It appears reasonable that at scales of 10^{-7} m the effects of gravity in molecular interactions and biophysical processes can be detected in timescales on the order of minutes to hours. A High resolution scanning probe microscopy platform would provide the needed tools to perform simple experiments only possible in orbit (low gravity) and a centrifuge (high gravity). The self assembly of organic compounds onto a "flat" surface will serve as a probe of gravity's role. Other applications include the construction of "nano-wires" which can be incorporated into biosensors, along with numerous applications to materials science and biotechnology.

Our science team has identified four simple experiments that will provide quantitative modeling constraints for biophysical molecular interactions. 1. Protein Folding 2. Self Assembly

of organic compounds onto “flat” substrates. 3. Growth of “Nano-wires” in microgravity. 4. Time lapse sequences of large single cell organisms in motion (compound light microscope only). Having only a few critical experiments makes it possible for the facility to be open to other researchers in the nanotechnology community with interests in a resolution of 10^{-10} m to 10^{-7} m in zero gravity. A strong belief that the secrets of the interactions at the boundary between macroscopic and microscopic scales can only be uncovered in open forum interdisciplinary research drives our program and instrument development.

Scanning Probe Microscopy

Scanning Probe Microscopy is a general term used to describe a type of microscopy in which a local probe is raster scanned over a sample of interest. As the probe is scanned across the sample, a local interaction between the probe and sample is measured. Scanning Probe Microscopes (SPMs) include the Scanning Tunneling Microscope (STM), the Atomic Force Microscope (AFM) and the Scanning Near Field Optical Microscope (SNOM). [2, 3, 9] **Figure 1** shows the schematic operation of a Scanning Tunneling Microscope (STM) and **Figure 2** shows the similar schematic for an Atomic Force Microscope (AFM).

SPMs are generally very sensitive to mechanical and acoustic noise, especially when imaging at the atomic scale. This usually requires some degree of vibration isolation. The instrument can be isolated from acoustic vibration by placing it under a vacuum. The mechanical vibrations usually require either an elaborate passive vibration isolation system or a sophisticated electronic active vibration isolation system. These microscopes can offer very high resolution images and measurements of various sample properties.

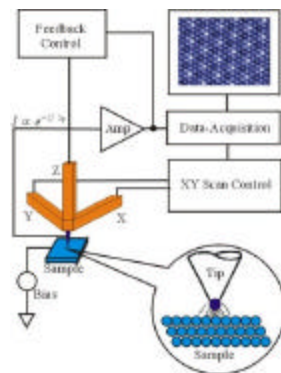

Figure 1: Scanning Tunneling Microscope (STM)

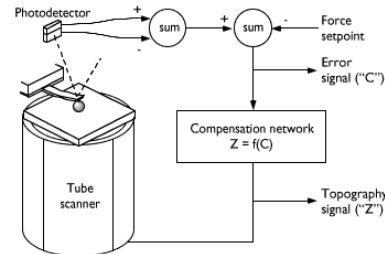

Figure 2: Atomic Force Microscope (AFM)

The International Space Station (ISS) is being assembled with various experimental apparatus and instrumentation in mind; however, a Scanning Probe Microscope (SPM) has not been intended. It is proposed that the SPM is an ideal instrument for materials characterization in space where direct atomic resolution can be obtained of crystalline materials and nanometer resolution can be obtained of noncrystalline materials. In addition, samples can be analyzed on the Space Station instead of returning them to Earth.

Recent interest has developed in sending an Atomic Force Microscope to Mars.[1] However, the operation of such an instrument in a microgravity/non-traditional laboratory environment had not been tested until recently.[10] A recent test flight of a commercially available AFM on the KC-135 indicates good feasibility for the performance of an SPM on the Space Station.[10] A versatile SPM on the Space Station would have a broad range of

application in microgravity research. Combined with a low resolution light microscope, the equipment shown below fits in a middeck locker equivalent space (MDE) to comprise the ZeroGravity Microscopy Analysis Platform (ZG-MAP).

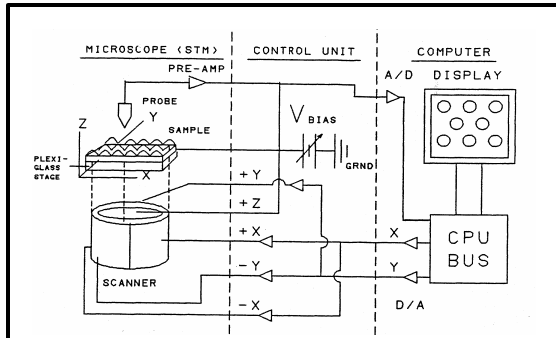

Figure 3 Schematic of the operation of an STM

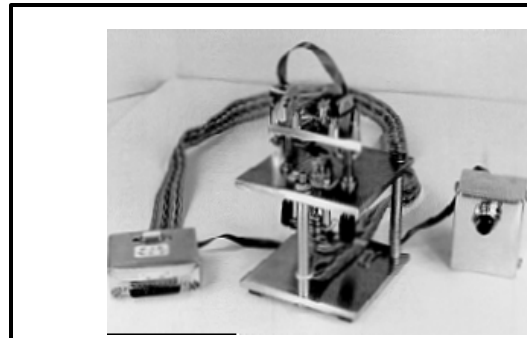

Figure 4: Picture of a home-made scanning tunneling microscope (The base plates are 4"x4")

The microscope is roughly 5" tall [9]

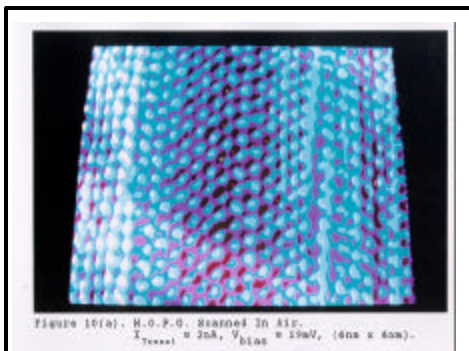

Figure 5: HOPG image from home made STM [9]

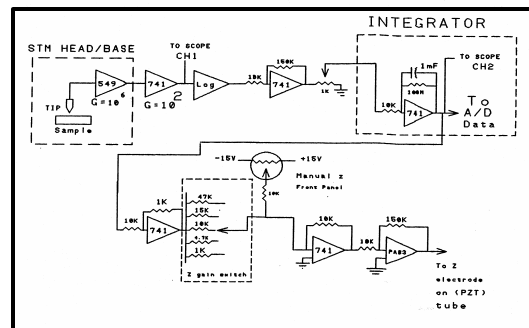

Figure 6 : Typical feedback electronics for a scanning tunneling microscope

Significant Student Contributions

The ZG-MAP team of the Association of Small Payload Researchers (ASPR) includes motivated science and engineering students. In the aftermath of Space Shuttle Columbia's disintegration our community finds itself waiting in a time of uncertainty. Our student members from Broward Community College have scheduled a flight aboard the KC-135 in the summer of 2003 in support of the ZG-MAP project. Their experiments will test sample and slide preparation techniques for zero gravity microscopy. It is worthwhile to note that their efforts, now more than ever, will help to maintain and further develop the

community grass roots interests in space exploration. With the NASA recognized importance of K-12 we are finding the community college environment to be a vital liaison to the “real world” of engineering.

References

- [1] Famars, The First AFM on Mars, <http://monet.physik.unibas.ch/famars/> October 10, 2000.
- [2] Binnig, G. & Rohrer, H., Scanning Tunneling Microscopy From Birth To Adolescence, Reviews of Modern Physics, Vol.59, No.3, Part I.
- [3] Chen, C.J., Introduction to Scanning Tunneling Microscopy, Oxford University Press, 1993.
- [4] Space Age Crystals, The art and science of crystal growing – on Earth and in Space. © 1992, The Kristal Corporation, Reno, Nevada 89511, USA.
- [5] DeLucas, L.J., et.al., “Preliminary Investigations of Protein Crystal Growth Using the Space Shuttle”, J. Crst. Growth **76**, 681 (1986).
- [6] Snell, E.H. et.al., “Improvements in lysozyme protein crystal perfection through microgravity growth”, Acta Cryst. D51. 1099-1102 (1995)
- [7] Ng, Sauter, Lorber, Kirkland, Arnez, Giege, “Comparative analysis of space – and earth-grown crystals of an aminoacyl-tRNA synthetase: Space grown crystals are more useful for structural determination” Acta Cryst. Section D: Biological Crystallography (2002).
- [8] Dror Sarid, Scanning Force Microscopy, Oxford University Press, © 1994.
- [9] Robert B. Friedfeld, The Construction and Calibration Of A Scanning Tunneling Microscope used To image Electrically Conductive Materials, Thesis, 1993.
- [10] S. Parker, R. Friedfeld, Resolution Limitations of a Scanning Probe Microscope in a Reduced Gravity, Vibration Intensive Environment, Final Report. (2001).
- [11] Branly, R.M. et. al., “Development and testing of Scanning Probe Microscopy for the Zero-g environment and International Space Station” Proceedings of the 39th Space Congress.
- [12] Branly, R.M. Friedfeld, R. Howard, E. Arcenaux, J. Carruthers, C. Jr. “Atomic Force Microscopy of DNA and Design Parameters for a Zero-g Operable Unit.” Proceedings of the 38th Space Congress