



---

The Space Congress® Proceedings

1992 (29th) Space - Quest For New Frontiers

---

Apr 23rd, 1:00 PM

## Paper Session III-B - In-Space Operations Driven Mars Transfer Vehicle System

Henry H. Woo  
*Rockwell International*

Ron Caldwell  
*Rockwell International*

W. Brimley  
*Spar Aerospace Limited*

Follow this and additional works at: <https://commons.erau.edu/space-congress-proceedings>

---

### Scholarly Commons Citation

Woo, Henry H.; Caldwell, Ron; and Brimley, W., "Paper Session III-B - In-Space Operations Driven Mars Transfer Vehicle System" (1992). *The Space Congress® Proceedings*. 12.

<https://commons.erau.edu/space-congress-proceedings/proceedings-1992-29th/april-23-1992/12>

This Event is brought to you for free and open access by the Conferences at Scholarly Commons. It has been accepted for inclusion in The Space Congress® Proceedings by an authorized administrator of Scholarly Commons. For more information, please contact [commons@erau.edu](mailto:commons@erau.edu).

**EMBRY-RIDDLE**  
Aeronautical University™  
SCHOLARLY COMMONS

## IN-SPACE OPERATIONS DRIVEN MARS TRANSFER VEHICLE SYSTEM

Henry H. Woo\* and Ron Caldwell\*  
Rockwell International, Downey, California 90241  
and

W. Brimley\*\*  
Spar Aerospace Limited, Weston, Ontario, Canada M9L2W6

Mars transfer vehicles (MTV's) using nuclear thermal propulsion (NTP) to reduce transit time introduce a new dimension in the design for in-space operations. The objective of the paper is to define practical concepts based on a set of design-for-operation strategies. An artificial-g MTV using NTP is characterized in this study. Manifests of MTV elements for the heavy lift launch vehicles (HLLV's) are shown to affect in-space assembly and maintenance requirements. A main goal is to minimize EVA operations during the assembly of a MTV in Low-Earth-Orbit (LEO). Self-build, self-build/depot hybrid, free-flyer robotic spacecrafts, build-up by lunar vehicles, and construction platform are concepts investigated. Maintainability analysis indicates that the self-build/depot hybrid concept is optimum over the self-build and platform concept.

### Introduction

The Stafford Synthesis Group set a goal of performing human exploration of Mars by 2016. This goal depends on NTP technology to reduce transit times and earth-to-orbit (ETO) costs. An artificial-g MTV with NTP, Fig. 1, has elements

such as hydrogen tanks, fuel lines, and nuclear engines which require intricate in-space assembly and maintenance operations. In-space operations requirements and concepts need to be developed in parallel with achieving the technology level needed to qualify the fuel, reactor, and engine/stage in the near future.

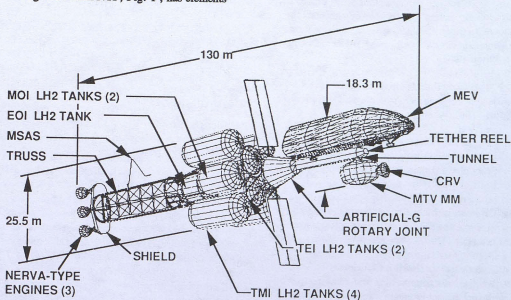

**Fig. 1 Rotary Joint, Tether Reel, and Reaction Control System  
Provide Artificial-g Capability For Mars Transfer**

\* Project Manager, Senior Member AIAA

\*\* Manager

## Design for System Operation Strategies

In-space operations at LEO must be addressed in terms of the number of ETO launches per mission, MTV element characteristics, assembly operations, crew activities, debris protection, maintenance, and supportability. The number of ETO flights per mission are kept to a minimum to minimize in-space assembly. Complexity in in-space assembly operations does not increase with the use of NTP. Instead, NTP eliminates the handling of propellant tanks with heavy liquid oxygen (LOX) required for chemical propulsion and the dual feed system. Since EVA operations require a crew size of 2 for EVA and 1 to 2 IVA, telerobotics is the preferred method for performing assembly operations with EVA for contingency operation. Our current experience with EVA is a maximum duration of 6 hours. However, if the 8 psi suits and the SSF type of extravehicular mobility units (EMU) are available, the pre-breathing and relocation time can be reduced. Space debris shields can be pre-installed around propellant tanks, habitation volumes, and engines to avoid damage. Storage of equipment for assembly and replacement of vehicle elements in case of damage must be planned. Logical "break points" must be determined for manufacturing, manifesting, assembly, inspection, and maintenance, to avoid the system being impacted by logistic delays.

Maintenance and support require a set of MTV design strategies which will facilitate operations. The strategies are:

- o Remote inspection of all hardware upon arrival on-orbit prior to and after assembly
- o Scheduled maintenance during assembly
- o Built-in sensors for monitoring and checkout
- o On-board vehicle element testing, trend analysis and fault isolation capabilities are integrated for in-space assembly and in-flight operations
- o Automated monitoring and service mechanisms conditioning and charging during assembly and in-flight operations

### ETO Capability and Impact on In-space Assembly

ETO capability is inversely proportional to in-space assembly of the MTV. If ETO capability is

limited, MTV elements are smaller and more assembly will be required. The relationship of IMLEO and the number of ETO launches required to deliver payloads to Mars' surface using NTP is shown in Fig. 2. The piloted short-stay (60 days) 2016 opportunity has one of the largest IMLEO's considered practical. For this mission, around 9 HLLV's of 150 t capability are needed. The long-stay (400-600 days) opportunities require lower IMLEO's and need 4 to 5 HLLV's of 150t capability. Assuming ETO launches at about 40 days intervals, the minimum time for the short-stay MTV in LEO is about 360 days. Unless a shorter LEO stay time is needed, a MTV design based on a 150t ETO capability is preferred over on a 250t ETO capability, because the increase volume capability is insignificant.

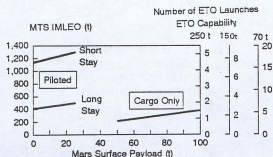

Fig. 2 Surface Payloads Drive Transportation Requirements

### Piloted MTV with Artificial-g

A piloted vehicle with artificial-g and NTP, Fig. 1, takes into consideration the above design strategies. Logical partitioning of elements is made to facilitate manufacturing, integration, testing, ground processing, manifesting, robotic assembly, inspection, and maintenance. The reference vehicle consists of an 89.5t MEV, a 49.2 t (286 cubic meter volume) manned mission module (MMM), a 7.5 t crew return vehicle (CRV), a nuclear stage, and 498.6t of LH2 propellant. The overall length of the Mars vehicle is about 2.3 times that of the Space Shuttle, but its mass is only about one half that of the Space Shuttle.

A Mars mission profile with abort alternatives is shown in Fig. 3. Three NTP engines

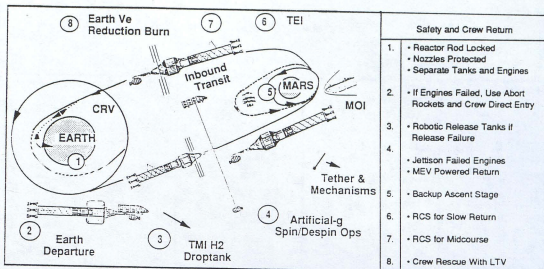

Fig. 3 Artificial-g Is Initiated After Midcourse And Terminated Prior to Mars Orbit Insertion

are used for planetary escape maneuvers. An individual failed engine cannot be shut down without immediately being ejected, since the shut down reactor generates enough heat through internally induced neutron leakage of the other reactors to destroy it. If all engines fail after trans-Mars-injection (TMI), the MEV would have adequate propulsion capability for return to Earth via a powered flyby at Mars.

After the outbound mid-course maneuver, the MEV and MMM are separated by 250 m and linked by a tether to the tower, then spun-up to 2 RPM to provide 0.7g. Gravity simulation greater than 0.38 g is needed to ensure sufficient crew physiological conditioning to withstand Mars entry. The artificial-g level is achieved by RCS in both bodies. The support tower has a rotary joint which allows the nuclear stage to remain unspun and maintain antenna pointing. Three days prior to Mars entry, the MEV and MMM are de-spun and retracted. The crew transfers from the MMM via a tunnel to the MEV, and then aerodescends onto the Martian surface. In the case where the primary Mars ascent vehicle engines fail to start, a backup ascent vehicle from a previous cargo mission can provide alternate ascent capability to Mars orbit. The crew returns from the Martian surface in an ascent stage that rendezvous with the MTV. Then, the MTV injects towards Earth. The crew return to

the earth surface in a CRV via direct entry. The reactors/engines are placed in a heliocentric disposal orbit.

#### MTV Element Manifest

There are many MTV manifest options. As an example, refer to Fig. 1, concept "A" brings up the MEV first in the assembly sequence. In this concept the drop tanks are brought up last. This reduces propellant boil-off between ETO delivery, and decreases the top-off requirements. In concept "B", the truss and engine cluster are delivered first. The truss provides structural support for system storage and attach points for a mobile manipulator to berth the propellant tanks. Concept "B" minimizes on-orbit wear of the avionics and reduces exposure of the habitable volumes to micro-meteoroids and debris. This concept requires an attitude control module (ACM) scared to the MTV or to a free flyer. In concept "C" the nuclear engines are delivered last. This concept also requires an ACM.

#### Packaging for Earth-to-Orbit HLLV Operations

The 150 t HLLV was used as the typical system to transport the MTV elements. The 150t HLLV reduces the number of propellant tanks to



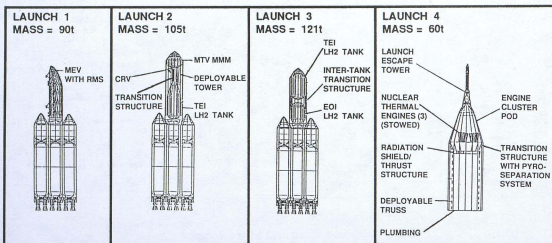

**Fig. 4. Launch Vehicle of 150 t Payload Capability Is Compatible With MTV Requirements**

LEO and allows delivery of fully integrated elements such as the MEV, MMM, and nuclear engine cluster. The HLLV payload envelope has a 9.4 meter length and a 33.5 meter diameter.

A typical method of stacking the MTV elements onto the HLLV is shown in Fig. 4 for the first four of nine launches of the manifest concept "A". The nuclear engine cluster is launched separately from the tanks. A launch escape subsystem and nose pod, for launch 4, is an option to encapsulate and protect the engine cluster from water penetration in case of launch system failure. The radiation shadow shield and truss are arranged to deflect metal fragments from penetrating the nose pod. Neutronic poison wires (Boron-Carbide) are in place within the fuel element cooling channels to ensure noncriticality of the reactor. The poison wires are removed prior to initial engine use.

#### Requirements for In-Space Assembly

In-space assembly requirements include power support, orbital maintenance, real-time communications with infrastructural systems and elements, telerobotic manipulators, systems check-

out, calibration, verification, inspections, fault detection, and fault identification capabilities. The installation of propellant tanks and fuel connections with engines are critical operations. This is due to potential leaking of interface seals and damaged fuel lines. These operations require effective robotics and mechanisms. Structural, fluid, or electrical interfaces are minimized and automated between the MTV elements and the assembly functions.

#### Supportability During In-Space MTV Assembly

As LEO stay time gets extended, supportability is a continuous burden for a robust operational system. Supportability includes the timely transport of spares and resupply of critical equipment. A support system including support equipment/tools, transport equipment, training equipment, and facilities must be developed and available along with well planned support activities. When MTV elements are delivered to LEO, test and checkout is conducted to verify acceptability for continuation of assembly. The support equipment for test and checkout may be a part of the first element delivered or in-place as part of the assembly

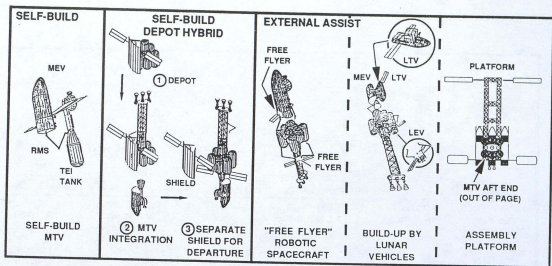

Fig. 5. Self-Build and Hybrid Concepts Require The Least Assembly Elements

system. If these support equipment are a part of the MTV, they can be reused throughout the mission.

Man-tended capabilities are essential in assuring that the MTV is configured on an acceptable schedule should a contingency arise. Manpower and support systems for contingency operations may be space-based at an assembly platform or as part of the MTV elements. A stable orbital altitude (220 Nmi) must be selected to reduce orbital decay. This allows sufficient time for ETO delivery.

#### Maintainability Requirements

The capability for maintaining the assembly system and support equipment is as equally important as the capability to replace critical MTV elements should failures occur during element checkout and inspection. Storage of spares, tools, support equipment, and transport equipment are required. Replacement propellant tanks, fuel lines, engine cluster, quick disconnects, and structures may be some of the replaceable MTV elements during assembly. However, MTV elements such as the MEV and manned module may not be considered practical as replaceable items, due to their complexity. However, subsystems within the MEV or the manned module such as avionics, life support, and smaller units are replaceable during assembly or in-flight.

#### Vehicle Assembly Concepts

Concepts for in-space assembly of the MTV are many, as shown in Fig. 5. It is assumed that a cargo transfer vehicle (CTV) provides the maneuvering capability for MTV elements in LEO. A self-build concept has the MEV in a gravity gradient flight mode with an option for attitude stabilization and employs a "self-relocatable" remote manipulator system (RMS) to berth the remaining vehicle elements. Communications and support equipment exist in the MEV and MMM which provide man-tended capability. This self-build concept involves proximity and RMS operations as shown in Fig. 6.

The self-build/depot hybrid concept utilizes a deployable micro-meteoroid shield containing housekeeping equipment with power, attitude control, and orbital maintenance subsystems. The hybrid concept provides basic utilities during the in-space assembly and shielding for the propellant tanks. The shielding consists of honeycomb panel structures.

In the two "free flyer" spacecraft concept, one spacecraft berths the MEV and MMM. A second spacecraft assembles the "propellant depot-like" portion of the MTV. The two spacecraft berth the forward and aft portion of the MTV, then separate after checkout of the MTV. A similar concept involves using Lunar vehicles for assembly

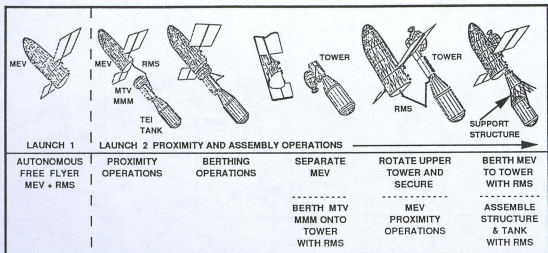

Fig. 6. Self Build Sequence Shows Proximity And Robotic Operations

of the MTV. The Lunar Transfer Vehicle (LTV) and Lunar Excursion Vehicle (LEV) are equipped with manipulators. A conventional concept is an assembly platform which could also store propellant. This concept requires build-up and maintenance of the platform.

#### Maintenance Predictions Analysis Of Assembly Concepts

The operational duty cycle should be kept low for any assembly concept. Maintenance predictions indicate that the self-build concept duty cycle must be below 18% as shown in Fig. 7, in order to minimize repair actions. As illustrated, the 55 maintenance removals for the platform is additive against the self-build assembly sequence. There is a need to maintain platform orbital operations prior to and during the assembly sequence of the MTV. Therefore the minimum amount of maintenance while using a platform would occur with a duty cycle of 5%. The self-build concept is more desirable than the platform concept; however, the self-build/depot hybrid concept is the most desirable with its debris protection and depot features.

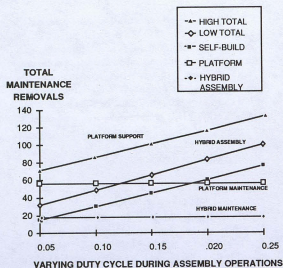

Fig. 7. Self-Build Assembly Sequence Reduces Overall Maintenance Burden

#### Robotics

The use of robotics and automation to handle predicted maintenance actions is necessary due to the complexity of EVA involving

## MSAS - MTS Servicing and Assembly System

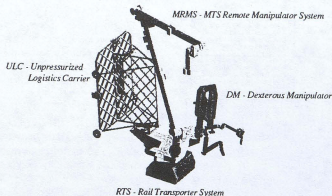

Fig. 8. On-Board Mobile Platform With Robotics System

prebreathing time, dual astronauts, and EVA time limitations. A potential MTS servicing and assembly system (MSAS), Fig. 8, provides for MTV assembly, remote inspection of interfaces, maintenance, and EVA crew activity support. The MSAS consists of the mobile transporter (MT), 7-DOF self-relocatable (17.6 meter) manipulator, a special purpose dexterous manipulator (SPDM), a logistic carrier, and all associated control equipment including the IVA control station.

### Time Estimates for In-Space Operations

In-space operation time is driven by vehicle element characteristics and the degree of automation employed as summarized in Table 1. Proximity operations during the delivery of MTV elements by a CTV is estimated about 4 hours. The time required for capture, snaring, and rigidization is a few minutes.

### Handling and Berthing

The manipulation of large and rigid masses such as the MEV and mission module by an RMS require some time for the settling of dynamics. The amplitude of the cantilevered body motion is critical

in the stopping distance and collision avoidance requirements. For example, the hydrogen tanks are large and have low frequency slosh dynamics that may require compensation within the RMS controller. Compensation for high mass payloads is presently being instituted into the Shuttle RMS. The SSF RMS is being designed to berth a fully loaded Shuttle orbiter (260K lbm) to the Space Station.

### Inspection and Testing

The MEV and the manned module have automatic checkout capabilities to monitor internal subsystems and the remaining MTV elements and their interfaces. Robotics provide a means to minimize EVA and allow verification and inspection of the outboard systems or elements. Inspection and testing of the tanks require the use of automated checkout equipment (embedded within the disconnects, panels, tanks, and control valves) that interface with the MEV and manned module. This capability is used to monitor the tanks once the system is attached as well as ready for flight.



Table I. Timeline Estimates Are Driven By Vehicle Elements Characteristics

OPERATIONS MTV ELEMENTS	HANDLING & BERTHING (Estimate *)	INSPECTION & TESTING
MEV (88) & MISSION MODULE (90)	* 1 TO 1.5 HOURS PER MODULE	* AUTOMATION - 3-6 HOURS * ROBOTICS - 5-8 HOURS PER MODULE
TANKS (158 L, 77L, 81L, 42L)	* 1.5 TO 3 HOURS PER TANK (8 TW, 2 MOL, 2 TEL, 1 EO)	* AUTOMATION - 3-8 HOURS * ROBOTICS - 5-8 HOURS PER TANK
INTEGRATED TRUSS & LINES (60)	* 8 TO 16 HOURS **	* AUTOMATION - 7-8 HOURS * ROBOTICS - 8-14 HOURS * EVA - 2 PERSON * 3 HOURS PER PERSON, 12 HRS TOTAL ***
ENGINES AND SHIELD (85.4)	* 1 TO 1.5 HOURS PER ENGINE CLUSTER	* AUTOMATION - 6-8 HOURS * ROBOTICS - 8-16 HOURS * EVA - 2 PERSON * 3 HOURS PER PERSON, 10 HRS TOTAL ***
INTEGRATED VEHICLE TESTING REQUIRES 64 HOURS		TOTAL INCLUDING INTEGRATED VEHICLE TESTS 279 TO 298 HOURS, ADD EVA AS NEEDED

\* BASED ON SSF BRIMS HANDLING REQUIREMENTS FOR PAYLOADS FROM 308 TO 116 L (LOCATE, BERTH, RELOCATE).  
\*\* DEPENDS ON DESIGN  
\*\*\* ASSUME NO PRE-BREATHING WITH NEW SUITS

Assessment of the recirculation network for liquid propellants also requires an embedded diagnostic capability once the nuclear system is integrated into the vehicle. Due to the complexity of the truss and fuel line segments, a combination of robotics, automation, and EVA is needed. The nuclear engine cluster may require the use of IVA personnel using robotic systems to inspect physical interfaces and removal of poison wires. Overall integration of the MTV requires final inspection and checkout of the entire flight configuration before commitment to a safe mission.

## Conclusions

A unique nuclear MTV design based on a set of design strategies has been derived incorporating provisions for artificial-g and for robotic in-space assembly and maintenance. The 150t class HLLV capability simplifies in-space operations. The self-build concept has less maintenance removal than platform concepts for duty cycles below 18%. The platform build-up concept has 55 maintenance actions during the assembly sequence. The self-build/depot hybrid has the most desirable features in terms of space debris protection, propellant storage, and mated capability.

## Acknowledgements

This study is a part of the on-going research sponsored by Rockwell International. This study includes contributions from H. Schmidt, Spar Aerospace Limited, and Rocketdyne Division.

## References

- Stafford, Gen. Thomas P., et. al, "America at the Threshold, Report of the Synthesis Group on America's Space Exploration Initiative," Available from the Superintendent of Documents, U. S. Government Printing Office, Washington, D. C. 20402, May, 1991.
- Woo, H. H., Glass, J. F., and Roy, C., "Design Of A Fast Mars Transfer System," AIAA Paper No. 92-0982, *AIAA Aerospace Design Conference*, Irvine, California, February 3-6, 1992.
- Joosten, K., Drake, B. G., Weaver, D. B., and Solder, J. K., "Mission Design Strategies for the Human Exploration of Mars," *42nd Congress of the International Astronautical Federation*, Montreal, Canada, October 5-11, 1991.
- Emrich, W. J., Young, A. C., and Mullqueen, J. A., "Nuclear Thermal Rocket Propulsion Application to Mars Mission," MSFC, Huntsville, Alabama, 1991.
- Green, J. A., "Considerations for Use of Artificial Gravity During Mars Missions," Internal Letter No. 279-300-91-026, Rockwell International Corporation, Space Systems Division, Downey, CA, June, 1991.
- Woo, H. H., So, K., and Kehrbaum, J., "Space Transfer Vehicle Deceleration To Planetary Orbit," AIAA Paper No. 90-2816, *AIAA Atmospheric Flight Mechanics Conference*, Portland, Oregon, August 20-22, 1990.
- "Nuclear Thermal Propulsion," NASA Conference Publication 10079, *Proceedings of the Nuclear Thermal Propulsion Workshop*, Sponsored by NASA Lewis Research Center, Cleveland, Ohio, July 10-12, 1990.
- Brimley, W. J. G., Kleinberg H., "On-Orbit Assembly of a Nuclear Mars Transfer Vehicle Using the SSF Mobile Servicing System Technology. Presented at LaRC, Hampton, July 24-26, 1991.