



The Space Congress® Proceedings

1993 (30th) Yesterday's Vision is Tomorrow's
Reality

Apr 27th, 2:00 PM - 5:00 PM

Paper Session I-C - Evolution of Lunar Based Optical Astronomy Facilities

John D. Hilchey

NASA, Program Development Directorate, Marshall Space Flight Center

Max E. Nein

NASA, Program Development Directorate, Marshall Space Flight Center

Follow this and additional works at: <https://commons.erau.edu/space-congress-proceedings>

Scholarly Commons Citation

Hilchey, John D. and Nein, Max E., "Paper Session I-C - Evolution of Lunar Based Optical Astronomy Facilities" (1993). *The Space Congress® Proceedings*. 9.

<https://commons.erau.edu/space-congress-proceedings/proceedings-1993-30th/april-27-1993/9>

This Event is brought to you for free and open access by the Conferences at Scholarly Commons. It has been accepted for inclusion in The Space Congress® Proceedings by an authorized administrator of Scholarly Commons. For more information, please contact commons@erau.edu.

EMBRY-RIDDLE
Aeronautical University™
SCHOLARLY COMMONS

Evolution of Lunar Based Optical Astronomy Facilities

John D. Hilchey¹ and Max E. Nein¹

ABSTRACT

The evolution of lunar based optical telescopes has been studied by the George C. Marshall Space Flight Center (MSFC) from early 1989 to the present. This paper describes four lunar based telescopes which form a logical evolution from a 1-m aperture, UV "transit" telescope to a 16-m aperture, IR/Vis/UV facility. Key trades and issues which will be encountered in developing these systems are discussed.

Experience has shown that developing and deploying a major space astronomy payload can stretch over as much as two decades. If the National Aeronautics and Space Administration (NASA) is to deploy the next generation of space-based telescopes within the next quarter-century, design planning must begin now to resolve the fundamental trades and major design issues raised by operating in the lunar environment.

Acknowledgment

The authors wish to express their thanks to Dr. John McGraw and members of the MSFC Lunar Telescope Working Group who have provided information for this paper.

Introduction

Our planned return to the Moon will herald the start of a decades-long drive to establish a permanent, multi-faceted observatory on the lunar surface. New generations of telescopes and instruments, developed to make detailed and sensitive measurements across the entire breadth of the electromagnetic spectrum, will examine the universe from this incomparable "mountain top". In a very real sense the Moon is an ideal spacecraft-platform waiting for the right instruments to be emplaced and operated.

The MSFC Lunar Telescope Working Group is engaged in a series of studies to define how NASA might develop, emplace, and operate astronomical telescopes on the Moon early in the next century to conduct cutting-edge astrophysical research. Four in-house conceptual design studies, over the period from early 1989 through the present, defined the Large Lunar Telescope (LLT), the Lunar Cluster Telescope Experiment (LCTE), the Lunar Transit Telescope (LTT), and the Lunar Ultraviolet Telescope Experiment (LUTE). Figure 1 shows the study schedule.

¹ Program Development Directorate, George C. Marshall Space Flight Center, NASA, Huntsville, AL 35812

The science goals and missions set forth by Illingsworth and Bely¹ were used to define the requirements for a telescope which would accomplish the cutting-edge science forecast for the early twenty first century. These requirements guided development of the LLT conceptual designs, deployment approaches, and operations plans

prepared in the first in-house study. MSFC then conducted studies which defined an incremental series of precursor systems (the LUTE, LTT, and LCTE) which could be initiated with current or planned transport capabilities and evolve to a full-fledged Lunar-based Astronomical Observatory characterized by LLT. Representative concepts are shown in Figure 2.

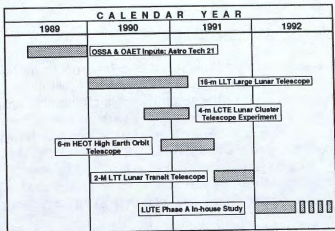

Figure 1. History of MSFC Lunar and HEO Telescope Studies: 1989 - 1992.

Science, mission, and system requirements were identified for each integrated telescope system; impacts of lunar environmental

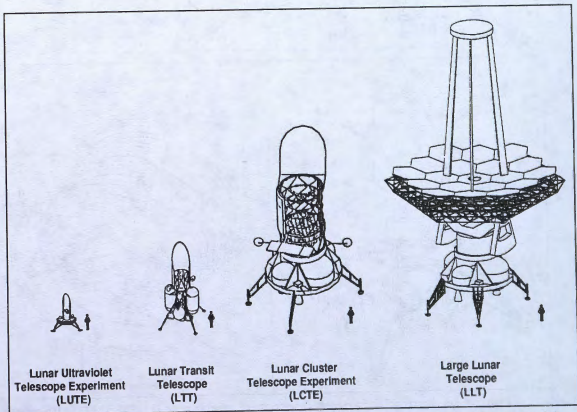

Figure 2. Baseline Concepts of Four Lunar-based Telescopes (to Same Scale).

factors were estimated; subsystem options were detailed; significant tradeoffs were examined; and feasible design approaches were selected. Appropriate system conceptual designs, technology requirements, and transportation and operations capabilities were developed for each astronomical facility. Study results are available or in preparation^{2 3 4 5}

Lunar Ultraviolet Telescope Experiment (LUTE)

The LUTE, first proposed by John McGraw⁶ is a 1-m UV telescope to be landed autonomously on the Moon and operated remotely from Earth. Its principal characteristics are summarized in Table 1, and a design concept is shown in Figure 3. The LUTE will achieve a 1° unvignetted field of view (FOV) with a compact optical system using three lightweight mirrors⁵. Its focal plane instrument will be a two-dimensional mosaic of charge coupled devices (CCDs). LUTE will not track specific targets, but point continuously at a celestial declination optimized to observe the North Galactic Cap. As the Moon rotates about its axis during its 28-day period, LUTE will image a 1.0° swath of the lunar sky, totalling more than 300 sq. deg. per year.

Table 1. Summary of Lunar Ultraviolet Telescope Experiment (LUTE) Payload Characteristics.

Estimated Mass (telescope only):	310 kg
Estimated Dimensions (Cylinder):	2.7 m l. x 1.1 m diam.
Estimated Power:	100 w continuous
Estimated Data Rate:	200 kbps continuous

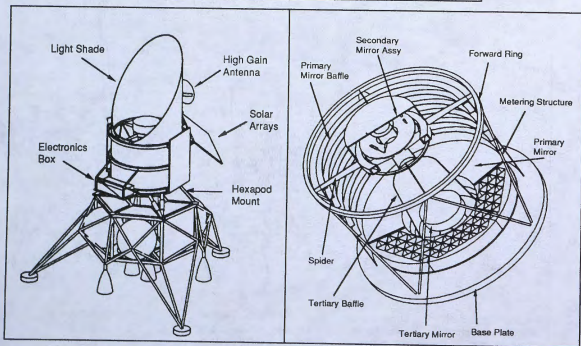

Figure 3. Lunar Ultraviolet Telescope Experiment (LUTE): LUTE Baseline Concept on Artemis Lander (left); LUTE Optical Bench (right).

This survey will cover the UV spectrum from 1000 - 3500 Å, imaging objects to an equivalent visual magnitude of 27, with a resolution of 0.5 arcsecond or better. The CCD mosaic will be read at the sidereal rate to produce a seamless "picture". Background "noise" from cosmic rays or radioisotope sources will be eliminated by a second CCD mosaic for anti-coincidence counting. The LUTE concept is proved by McGraw's existing, ground-based CCD Transit Instrument (CTI), currently supporting stellar survey studies ⁷.

The LUTE will be passively cooled by radiation to deep space; mirrors and focal plane instruments will be protected from direct and scattered sunlight and thermal radiation by a sun shade ⁵. Power will be provided by solar arrays in the baseline configuration, limiting LUTE to daytime operations. Continuous day-and-night operations could be enabled by substituting a Radioisotope Thermal Generator (RTG) as the power source. Science and housekeeping data will be transmitted continuously by the LUTE communications system directly to Earth for processing, distribution, and archiving.

LUTE could be launched directly to the Moon aboard an Atlas II AS or other comparable launch vehicle. Selecting the site for LUTE deployment involves a complex tradeoff largely dominated by: (1) thermal problems imposed by the lower latitudes; (2) problems of pointing to eliminate interference by direct and reflected sun and Earth albedo; and by (3) difficulties inherent in the nature of the lunar surface which is rough and broken even on the smallest of scales ¹⁴.

Lunar Transit Telescope (LTT)

The Lunar Transit Telescope (LTT), is a 2 m-class, fixed-declination, optical telescope also proposed by McGraw ⁸. LTT will be the logical high performance instrument to follow and expand the work of the LUTE. The 4-mirror optical system will consist of a 2-m very low weight primary mirror and two active-optics correcting mirrors ⁴. The LTT will operate as a transit telescope with a 1.5 ° FOV and a significantly increased resolution of 0.1 arcsecond or better. Its spectral range will cover 0.1 - 2 microns, imaging the infrared and visible regions of the spectrum as well as the ultraviolet. LTT would image the celestial sphere, typically, at the rate of 575 - 720 sq. deg. per lunar day, but may be designed to make periodic, small pointing adjustments to increase celestial coverage. The optical elements are supported by a light weight metering structure and protected from unwanted heat and light by a special sunshade and the thermal / light shield which also protect against dust and micrometeoroids ^{9,10}. A summary of the telescope's principal characteristics is provided in Table 2, and the baseline design concept is illustrated in Figure 4.

Table 2. Summary of Lunar Transit Telescope (LTT) Payload Characteristics.

Estimated Mass:	2981 kg (LTT & lander)
Estimated Dimensions (Cylinder):	5.31 m l. x 2.1 m diam.
Estimated Power:	600 w maximum
Estimated Data Rate:	3.0 MBPS maximum

The telescope will be integrated with an autonomous landing system specifically designed to emplace the LTT on the lunar surface. Subsystems providing power, thermal control, communications, and data handling would be shared between the telescope and the landing system. The lander will also serve as a platform for LTT science operations, fulfilling the functions of telescope base and command center. This integrated payload will be launched directly to the Moon aboard a Titan IV - Centaur launch vehicle.

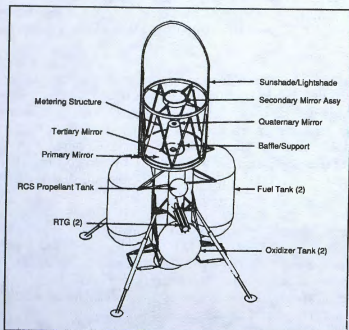

Figure 4. Lunar Transit Telescope: Baseline Configuration, Cutaway View.

Choice of a landing site for the LTT will be subject to the same tradeoffs as the LUTE, with one added consideration. The proposed operational lifetime of the LTT would be about 15 years. Therefore, selection of a site within a few tens of kilometers of the First Lunar Outpost would be desirable to permit outpost crews to maintain, repair, and upgrade the telescope to meet evolving science requirements

Choice of a landing site for the LTT will be subject to the same tradeoffs as the LUTE, with one added consideration. The proposed operational lifetime of the LTT would be about 15 years. Therefore, selection of a site within a few tens of kilometers of the First Lunar Outpost would be desirable to permit outpost crews to maintain, repair, and upgrade the telescope to meet evolving science requirements

Lunar Cluster Telescope Experiment (LCTE)

The LCTE is a major astronomical instrument for early, automated emplacement on the lunar surface. There it will effect a significant reduction in the cost of providing high returns from lunar science investment. Simultaneously, the LCTE will be the lunar testbed for development of large lunar optical instruments. It will provide essential evaluation and validation of LLT development concerns, such as active optics mirror systems and other technologies, designs, fabrication techniques, science operations approaches, and maintenance concepts for the LLT.

The LCTE³ is a 4-meter class optical telescope with an operating bandwidth of 0.1 - 10 microns in the ultraviolet, visible, and infrared ranges of the spectrum. The system is based on a detector mosaic for diffraction limited imaging; its FOV is 20 arcseconds in the UV and 2 arcminutes in the visible and IR regions. LCTE features six linear actuators to point and track targets for integration times up to many hours. They also provide 14-degree half-cone pointing of the telescope so objects of interest over 25% of the celestial sphere are viewable over a one month period. Table 3 and Figure 5 show the main payload characteristics and the baseline configuration³.

Table 3. Summary of Lunar Cluster Telescope (LCTE)
Payload Characteristics.

Estimated Mass:	6882 kg (LCTE only)
Estimated Dimensions (Cylinder):	8.35 m l. x 5 m diam.
Estimated Power:	1555 w maximum
Estimated Data Rate:	400 kBPS maximum

LCTE's optics consist of a primary formed from an actively corrected cluster of 54 LLT-type mirror segments. The design is completed with a monolithic secondary and a deformable tertiary. The secondary mirror provides a fourth reflection from a specially ground central area to the three science instruments mounted on the optical bench aft of the primary.

All subsystems for such telescope functions as optical alignment, pointing and tracking, communications and data handling, etc. are contained within the telescope and support structure. Passive thermal protection on the telescope and special shields to minimize daylight heating, will allow the mirror to attain temperatures as low as 65 K for a significant portion of the lunar night. This would increase the sensitivity of the LCTE system two orders of magnitude compared to the Lunar Transit Telescope. Active thermal control is provided for detectors as well as the experiment and subsystem equipment located beneath the primary mirror. Advanced photon counting devices and improved systems for reducing the background noise from cosmic ray events and radioisotope heaters and power supplies will be incorporated.

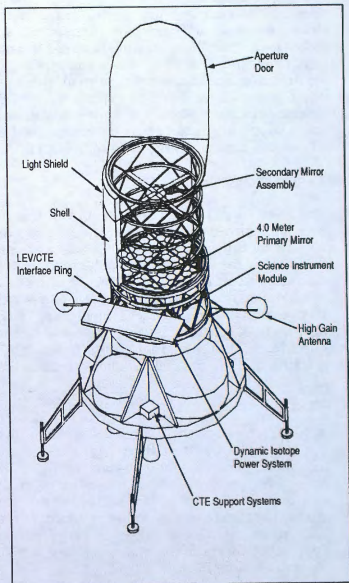

Figure 5. Lunar Cluster Telescope Experiment; Baseline Configuration.

The LCTE could be designed for automated deployment and would be fully assembled and integrated with its lander on Earth. The lander, a precursor of the Lunar Excursion Vehicle (LEV), would also serve as telescope mount and foundation. The integrated LCTE and LEV-lander would be launched direct to the lunar surface by a vehicle in the Heavy Lift Launch Vehicle (HLLV) class.

If delivery of the LCTE to the Moon is planned to occur after crews are available to erect it on the lunar surface, the LCTE could be designed not only as the lunar testbed, but also as the first increment in the buildup of the future 16-m LLT. It would require one cluster of LLT mirror segments as a primary, the secondary and tertiary mirrors, the telescope mount and base, plus a minimum of structural and optical elements. These could be erected by astronauts in a field test of lunar surface science construction. Initially, reduced capacity subsystems including special structures, thermal and light control, dust and meteoroid protection, etc., would be employed to bring the LCTE to "first light". These would be superseded by definitive LLT elements provided as the telescope evolves. Major protective structures, the instrument chamber, and other large supporting items would be incorporated by Lunar Base crews as new clusters of primary segments are added to the LCTE.

Large Lunar Telescope (LLT)

The 16-m Large Lunar Telescope (LLT) will be a feature of the Lunar Observatory to be established on the Moon in the first two decades of the Twenty-first Century. Experience in developing and operating small optical telescopes in the mid-to-late '90s will prepare the way for a national investment in the unique science potential of this next-generation facility. The LLT will extract the maximum benefit from its unique combination of design characteristics. Among these are: its unsurpassed aperture; its design to provide unprecedentedly long integration times; and its ability to take advantage of positive aspects of a lunar site such as the absence of atmospheric obscuration, the minimum of interfering light, the geologically ultra-stable lunar platform and the uniquely predictable environment.

LLT is a 16-m class, UV/Vis/IR telescope ² operating over the spectral bandwidth of 0.1 - 10 microns, based on a detector mosaic for diffraction limited imaging. The FOV is 20 arcseconds in the UV and 2 arcminutes in the visible and IR regions. Optics of the LLT will consist of three mirrors: a 16-m, segmented primary mirror plus monolithic secondary and tertiary mirrors. The 1098 primary segments will be actively corrected to maintain the mirror figure regardless of variations in the thermal environment. The secondary mirror will provide a fourth reflection from a specially ground central area into a Coude' system to direct the light beam into an underground instrument chamber whatever the orientation of the LLT. The tetrahedral truss supporting the primary, the secondary tripod, and other dimensionally critical elements will be formed of lightweight, thermally stable materials. The truss will interface with the yoke of an alt-azimuth mount integrated with a modified Lunar Excursion Vehicle (LEV) during transport to the Moon. The foundation and base for the LLT will be transported to the Moon as separate elements. Table 4 and Figure 6 show LLT's principal payload characteristics and baseline configuration ²

Special design approaches will be required to deal with the impacts of the radiation, thermal, dust, and micrometeoroid environments. A protective "dome" and other passive measures will minimize thermal loading of the telescope during the lunar day. Supplemental active thermal control systems will be employed to eliminate thermal residuals not completely controlled by passive techniques. The dome will also defend against certain sizes of micrometeoroids and block out dust lofted by rocket vehicles and other operational events. The chamber housing the scientific instrument carousel will be covered with several meters of regolith to mitigate the effects of cosmic radiation on Charge Coupled Devices operating as the heart of the LLT's instruments. Subsystems support such as power, communications, and data handling may be provided by subsystems installed at the LLT site, or supplied by the Lunar Base

Table 5. Summary of Large Lunar Telescope (LLT)
Payload Characteristics.

Estimated Mass:	24500 kg (all elements)
Estimated Dimensions:	16 m wide x 32 m tall
Estimated Power:	5580 w maximum
Estimated Data Rate:	2.5 MBPS maximum

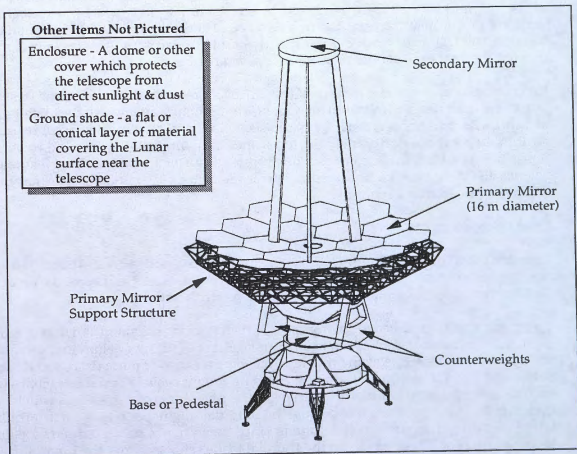

Figure 6. Large Lunar Telescope, 16-m (LLT 16-m): Baseline Configuration.

depending on how far the telescope is sited from the Base.

The LLT site will be on the near side of the Moon to simplify continuous data transmission to Earth and on flat terrain with a minimum of cratering. Major trades are required to select the best nearside location¹⁴. One popular option is to site the LLT on the Moon's limb to minimize effects of Earth light, micrometeoroids, and dust from lunar outpost activities. However, serious consideration must be given to locating the LLT only a few tens of kilometers from the Lunar Base. This would reduce Base Interference problems, and still enable us to protect our national investment in a very complex and valuable scientific facility. In this way we could take advantage of the outpost crew skills to accomplish LTT construction, maintenance, repair, and evolution without incurring unacceptable travel and logistics penalties.

Several options exist for deploying the LTT to the lunar surface². If a combination of Shuttle, Lunar Transport Vehicle (LTV), and Lunar Excursion Vehicle (LEV) must be used, delivering an LLT with standard foundation and base to the Moon will require two shuttle launches; integration with the LTV and LEV in Low Earth Orbit; and transfer to the lunar surface for assembly. The suggestion has been made that a LEV might be substituted for the more usual type of base. This might permit integration of the LLT and LEV on Earth, followed by direct launch to the Moon with certain versions of the new National Launch System. However, it is highly questionable whether the LEV can provide a sufficiently stable underpinning, especially during diurnal thermal excursions, to serve as a permanent mount and base.

Erection, alignment, and checkout of the LLT by astronauts from the Lunar Base, or by a dedicated crew, will follow an incremental approach, starting with the installation of only those primary segments (plus the secondary and tertiary elements) required for initial operation. Fortunately the telescope could immediately be used to obtain first-class data early in the construction process, assuring that the LLT harvests early science dividends. Additions of further mirror segments will complete the primary and establish full science capability.

Lunar Environment

The chief environmental factors influencing lunar telescope design and operation are: the thermal environment, cosmic radiation, micrometeoroids and secondary ejecta, and surface dust. Each of these is reviewed briefly below.

Thermal: The lunar thermal environment, which is much harsher than that of Earth orbit, offers particular challenges in lunar telescope design. For instance, the temperature of telescope elements may cycle over a range of more than 300 K (from below 100 K to above 400 K) during the lunar day-night cycle⁹. Lunar telescopes will require special design solutions to deal with the severe thermal gradients which can build up in their components during the long day-night periods. Earth orbiting telescopes do not require such solutions since they are not subjected to these long heating and cooling cycles nor to the thermal loads reflected from the lunar surface even from the anti-solar direction.

Two main aims in the LUTE thermal design have been to (a) minimize thermal effects on the dimensional stability of telescope elements and (b) prevent physical damage to telescope elements, e.g., electronic components, during the long lunar nights when the low temperatures may affect their longevity.

Maintaining dimensional stability in structures and mirrors is the foremost need. Temperature gradients across telescope mirrors may distort their optical figures unacceptably, while thermally induced changes in the metering structure may alter the optical alignment or the focus of the optical subsystem. Measures to eliminate or compensate for these effects include facilitating rapid dissipation of excess heat in sensitive areas and enhancing thermal equilibration processes to minimize thermal differentials and gradients.

Passive approaches include such techniques as: (a) choosing materials and adjusting coatings to provide desired absorptivity and emissivity of surfaces; (c) selecting materials and design approaches so that thermal responses of the design elements compensate each other to minimize net thermal effects; (d) using heat-pipes and other advanced thermal design techniques to dissipate thermal peaks; and (e) providing shelters for the advanced systems.

Active measures can be used to manage thermal problems if sufficient power is available, as in the LTT, LCTE, and LLT. They might include such standard approaches as actively transferring heat to radiators which see only the cold lunar sky, or applying cryo-coolers to sensitive detectors. Heaters may also be used to help maintain telescope elements at desired operating temperatures, and active optics techniques may be used to compensate directly for the residual distortions of the mirrors.

Preventing permanent thermal damage to telescope elements will depend largely on the principal parameter leading to element failure. Damage may depend on the extreme of temperature, the duration of the "soak" at the extreme, the range of temperature during a diurnal cycle, or / and the frequency of the cycle. For instance, in the case of telescope mirrors the problem will not be constant high or low temperatures. Instead it is the constant cycling between the extremes which impact the temperature dependent properties of inhomogeneous materials used in mirrors and affecting the stability of the mirror.

In the case of telescope electronics, in contrast, the thermal impact may be caused simply by a relatively short duration exposure of the electronics package to a low temperature. For instance, electronics components may not survive one lunar night unless they are protected by localized heating to a temperature in the neighborhood of 223 K (-50 ° C). The use of Radioisotope Heater Units (RHU's) is being explored to maintain sensitive electronics of the LUTE at the temperature required to preclude any cold-soak damage since LUTE's photovoltaic power for heat will not be available during the lunar night.

Later telescopes designed for infrared observations will require special care in thermal

design to prevent thermal "noise" from interfering with IR detector operation. In addition to using techniques described above, designers must assure that the detector does not "see" thermal radiation from the telescope structure and shields.

Cosmic Radiation: Galactic cosmic rays (GCRs), and the secondary ionizing particle radiation produced from the telescope structures they impact, will interfere with the gathering of scientific data and may permanently damage elements of the CCDs used in focal plane instruments ¹¹. From the scientist's point of view, the immediate concern is the electronic noise which will be generated in the photodetectors. This background noise will be produced when a GCR and its secondaries strike pixels of the CCD. In automatically deployed telescopes too small to warrant emplacement by a lunar crew, the most practical solution will be to use anti-coincidence counting techniques to eliminate noise from the data record.

In larger, crew-erected telescopes the choice might be to provide a shield of lunar regolith over a separate instrument chamber as in the case of the LLT. It can be shown that 1 - 2 m of compacted regolith would be sufficient to bring the background radiation down to a level equivalent to that at which the Hubble Space Telescope operates in low Earth orbit. An instrument chamber under a mound of soil below, or at the side of a lunar-based telescope, would provide the necessary protection. This solution must be traded off against the optical throughput losses inherent in the added reflections of the beam through the Coude' directing the beam to the fixed instruments under the shielding.

Heavy GCR's can also interfere with the proper operation of CCD's by damaging the detector itself, displacing atoms in its structure and degrading detector performance over time. However, the rate of damage is sufficiently low that it will be possible to keep ahead of the damage process. The degradation of the focal plane CCD's can be tracked by periodically assessing data sent back by the telescope. When CCD performance trends down to an unsatisfactory level, the focal plane CCD can be replaced during maintenance or upgrade visits by Lunar Outpost personnel.

Dust: Problems of dealing with lunar surface dust and its impact on lunar-based telescopes are a significant concern in design ². For instance, dust lofted by an automated landing of a telescope, or by human activities in its vicinity, can interfere significantly with telescope operations. Granules a few microns in size are a normal component of lunar soil. This dust is easily disturbed and can be boosted from the surface by relatively small impelling events as well as by landings or launches. In the airless lunar environment these particles follow ballistic trajectories and can travel large distances before returning to the surface to contaminate or damage telescope optics or mechanisms. A study of foundation design, construction, and environmental mitigation," for the LLT has been carried out ¹²; to date, few effects of this dust on telescope design and performance have been modeled to a point where they can be taken into account quantitatively in telescope designs.

The ballistic behavior of lunar dust is relatively well understood, but there are other effects for which complete explanations are still lacking. Electrostatic charging

mechanisms thought to be associated with passage of the solar terminator may be sufficient to levitate fine dust grains and propel them across the lunar surface. It has been reported¹³ that calculations have indicated these electrostatic effects might levitate dust to 10 m, enabling them to reach the LLT primary mirror and the LCTE secondary or engulf the whole LUTE. Damage and accumulations of dust were seen on surfaces of the revisited Surveyor 3 lander. Although these effects may have been caused by the landing of the Apollo Lunar Excursion Module (LEM) itself, they illustrate the problems lunar telescope designers must solve.

Regardless of the way in which surfaces become contaminated or the degree of accumulation, removal is reported to be difficult under all circumstances. Therefore exclusion may prove to be the more effect mode of mitigation. Primary dust mitigation will be achieved, if possible, through judicious selection of telescope sites. In addition, protection for sensitive mirror elements, pointing mechanisms, and thermal control surfaces must be incorporated into the telescope design to fend off dust lofted by natural events and man's activities on the Moon. These two approaches will probably suffice for small, auto-landed systems such as the LTT and its derivatives. Additional protective hardware such as telescope domes or covers may be required for large systems like the LLT and LCTE. Finally, novel methods for safely mobilizing unwanted material from sensitive optical and mechanical surfaces of manned and, especially, unmanned telescopes must be developed.

Micrometeoroids and Secondary Ejecta: A similar environmental concern is the micrometeoroids which constantly impact the lunar surface with masses ranging from 1 picogram to 1 gram. The effect of the primary impacts by these masses is multiplied by the many secondary ejecta produced by the landing of the primary bodies. As in the case of protecting against dust and abating the problems it causes, proper design of the telescopes and the protective structures, mechanisms, and other subsystems that comprise and support them will eliminate or significantly reduce the influence of this environmental factor on telescope operations.

Design Trades and Parameter Interactions:

Placement of telescopes on the Moon has many advantages as pointed out by a number of authors and organizations^{16,7,8,15}. However, designing even the simplest lunar telescope involves many more technical trades than is normally the case for an Earth orbiting telescopes^{4,5}. One general principle has governed these trades in the MSFC studies: supporting subsystem weights must be kept to a minimum in order to preserve a high yield of science payload delivered to the Moon in a scientifically profitable operational condition.

As a result such seemingly diverse characteristics of a lunar telescope system and 2M LTT mission as:

- telescope focal length,
- detector technology,
- lander landing attitude errors,
- lunar site latitude,
- science operations requirements,
- power source choice,

- mirror material,
- thermal design
- lunar surface roughness, and

become intimately related drivers in the selection and definition of the design.

For instance:

- Stringent science performance requirements may dictate the resolution and focal length required for the telescope.
- These choices largely determine the pixel size of the detector.
- A longer focal length allows larger pixels, which are easier to manufacture and thereby less expensive.
- On the other hand, a longer focal length increases the dimensions of the telescope light shield, causing thermal problems for the optics.
- This may, in turn, force selection of a higher latitude landing site which could compromise the scientific effectiveness of a transit telescope.

Frequently these trades may follow an almost "circular" logic. This will require planners to iterate these complex trades a number of times in order to define and develop a lunar-based telescope which will serve the science mission with a maximum of operational capability, but within reasonable cost limits, and on a timely schedule.

Figure 7 is a top-level sketch of some significant parameter interactions which must be considered in designing lunar-based telescopes. It illustrates the way the design parameters for practically every subsystem can be coupled mutually to the other parameters and subsystems. They are likewise strongly coupled to operational considerations such as deployment site location and day / night operations requirements.

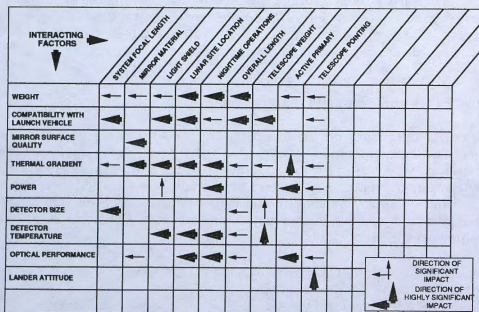

Figure 7. Significant Trades and Parameter Interactions in the Design of the Lunar Ultraviolet Telescope Experiment (LUTE).

The figure itself is incomplete; other factors and their interactions are being added. Note how simple an interaction can appear; mirror surface quality now seems affected only by the choice of mirror materials. However, this relationship will become more complex once the implications of lunar surface dust and its properties are added to the illustration. In another case, most factors shown can have some negative impact on the compatibility of the telescope with its Earth launch vehicle, but still a relatively straightforward design problem.

In a third case, if choices of focal length, material, site, operations requirements, etc., severely increase mirror thermal gradients, relief may be available to designers. They can take advantage of new active optics technologies to correct mirror figures for thermal distortions. That is the "good news". The "bad news" is that this option may apply only at the cost of much complexity in the optical system, with its potential for problems in still another trade, namely: reliability versus maintainability.

Failure to resolve such 'circular trades' early in the definition and design process, can force system and mission redesigns late in the development process. These inevitably result in unacceptable redesign costs, schedule and manifest impacts, and crippling science compromises. Early mission and system concept planning and definition, supported by a continuing commitment of significant resources to technology development, provide the best way to resolve this impasse. This combined approach has been shown in practice to relieve mission requirements, relax design constraints, and untangle complex trade issues, resulting in simplified, more effective system development and science operation.

Telescope Schedules:

History has shown that 15 to 25 years are required to move a large space telescope from concept formulation to first operation. Figure 8 illustrates the development cycle of space telescopes based on 25 year's experience with the telescopes shown. Definition and development times for these systems ranged from 10 to 20 years, while precursor technology work pushed up the total by about another 5 years. The message is that a period of some 20 years, is not an anomalous time average to bring a new major astronomical facility on line. This

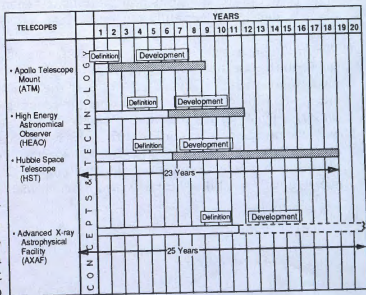

Figure 8. Estimated Schedule Experience in Development of Space Telescopes

historical estimate cannot account for future schedule slippages due to budget constraints or other, non-technical circumstances. Note that this chart was developed two years ago and does not reflect the most recent events!

Technology availability drives the discipline of observational astronomy. From the time it began almost 400 years ago with the small telescope of Galileo this has been so, especially for the sophisticated instruments of today. The technologies needed for the next generation of space telescopes will not emerge solely on the basis of the astronomy community's need. Instead, their development depends, to a large degree, on the requirements of other disciplines. In the past national defense requirements have enabled the emergence of new, radical technologies essential for the advance of many scientific disciplines.

For example, studies of active optics technologies were accelerated and systems developed to satisfy urgent defense-related purposes. Now that these technologies have been made generally available, they have provided immense benefits by advancing Earth-based astronomy. As defense-oriented developments diminish in the future, they must be replaced by a project-oriented technology development period preceding any serious design efforts for large telescopes. Without the previous defense-related urgency, this period will typically last 5 - 10 years.

Science planners have seen the powerful advantages inherent in establishing a major astronomical capability on the lunar surface early in the next century. Our experience tells us that if we are to achieve the desired capability by the time the Hubble Space Telescope reaches the end of its anticipated life, (2005 - 2010), we must act now. We must clearly establish that goal and commit the resources needed to:

- identify the logical evolutionary steps;
- detail the missions and systems to accomplish each step; and
- develop the enabling technologies.

We must begin now the firm definition and development of a LUTE-class lunar telescope as the most direct and scientifically profitable first course towards the goal. Experience with the Skylab telescopes of the Apollo Telescope Mount has shown that small, technologically less demanding, telescopes can be developed as "pathfinders" for larger systems in a reasonable length of time. Then, with the LUTE program under way, we must act to assure that the long range scientific goal is not lost in the press and excitement of achieving the immediate first step. We must expedite continuous planning to define the missions and systems on which to base a national program to evolve a full-capability Lunar-based Astronomical Observatory.

References

1. Bely, P., C. J. Burrows, and G. D. Illingworth (1989), Eds., "The Next Generation Space Telescope." Proceedings of Workshop, Space Telescope Science Institute, Baltimore, MD.
2. MSFC Lunar Telescope Working Group (1991A), "Large Lunar Telescope (LLT): 16-m Aperture UV/Visible/IR Telescope." Report No. LLT-001, Program Development Directorate, Geo. C. Marshall Space Flight Center, Huntsville, AL.
3. MSFC Lunar Telescope Working Group (1991B), "Lunar Cluster Telescope Experiment (LCTE): Technology Precursor to the Large Lunar Telescope." Report No. LLT-002, Program Development Directorate, Geo. C. Marshall Space Flight Center, Huntsville, AL.
4. MSFC Lunar Telescope Working Group (1992), "Lunar Transit Telescope (LTT): 2-m Aperture UV/VIS/IR Telescope." Report No. LLT-004, Program Development Directorate, Geo. C. Marshall Space Flight Center, Huntsville, AL.
5. MSFC Lunar Telescope Working Group (In Preparation), "Lunar Ultraviolet Transit Experiment (LUTE)." Report No. LLT-005, Program Development Directorate, Geo. C. Marshall Space Flight Center, AL.
6. McGraw, John T. (1992), "Lunar Ultraviolet Transit Experiment (LUTE), (A Lunar Transit Telescope [LTT] Precursor Mission)." Proposal to Johnson Space Center, Steward Observatory, Univ. of Arizona, Tuscon, AZ.
7. McGraw, John T. and G. F. Benedict (1990), "Scientific Programs of a Lunar Transit Telescope (LTT)," p. 464, AIP Conf. Proc. 207, "Astrophysics From the Moon," eds. M. J. Mumma and H. J. Smith, Annapolis, MD.
8. McGraw, John T. (1990), "An Early Lunar-based Telescope: The Lunar Transit Telescope (LTT)," p. 433, AIP Conf. Proc. 207, "Astrophysics From the Moon," eds. M. J. Mumma and H. J. Smith, Annapolis, MD.
9. Walker, S. (1991), "Large Lunar Telescope, Final Report: Thermal Analysis." NASA, MSFC, Huntsville, AL.
10. Gerry, M. (1991), "Large Lunar Telescope, Final Report: Telescope Configurations." NASA, MSFC, Huntsville, AL.
11. Johnson, C. L., and K. L. Dietz (1991), "Effects of the Lunar Environment on Optical Telescopes and Instruments." SPIE Conference 1494: Space Astronomical Telescopes and Instruments, Orlando, FL.
12. Chua, K. M. and S. W. Johnson (1992), "Large Lunar Telescope: Foundation Design, Construction, and Environmental Mitigation." NASA Grant No. AP54-NAG8-856, MSFC, Huntsville, AL.
13. Helken, G. H., D. T. Vaniman and B. M. French (1991), "Lunar Sourcebook: A User's Guide to the Moon." [¶ 9.2.3, p. 532], Cambridge University Press, Cambridge, UK.
14. McCarter, J. (1991), "Large Lunar Telescope, Final Report: Site Selection and Viewing Analysis." NASA, MSFC, Huntsville, AL.
15. Malina, Roger F., (LTT and LUTE Endorsements by the UV/Optical/Gravity Physics MOWG), letter communication to Dr. Charles J. Pellerin, Office of Space Sciences and Applications, NASA, dated February 20, 1992.