



The Space Congress® Proceedings

2001 (38th) A Space Odyssey - The Next 50
Years

May 2nd, 2:00 PM

Paper Session II-B - High Efficiency Hyperspectral Imager for the Terrestrial and Atmospheric Multispectral Explorer

R. Glenn Sellar

Florida Space Institute, MS: FSI KSC

Rolando Branly

Broward Community College

Adam I. Ayala

Florida Space Institute, MS: FSI KSC

Patrick L. Bertiaux

Florida Space Institute, MS: FSI KSC

David S. Desrochers

Florida Space Institute, MS: FSI KSC

See next page for additional authors

Follow this and additional works at: <https://commons.erau.edu/space-congress-proceedings>

Scholarly Commons Citation

Sellar, R. Glenn; Branly, Rolando; Ayala, Adam I.; Bertiaux, Patrick L.; Desrochers, David S.; Girard, Christopher J.; Johnson, David C.; Mayer, Andrew P.; Ku O, Chae; and Schaub, Ron, "Paper Session II-B - High Efficiency Hyperspectral Imager for the Terrestrial and Atmospheric Multispectral Explorer" (2001). *The Space Congress® Proceedings*. 14.

<https://commons.erau.edu/space-congress-proceedings/proceedings-2001-38th/may-2-2001/14>

This Event is brought to you for free and open access by the Conferences at Scholarly Commons. It has been accepted for inclusion in The Space Congress® Proceedings by an authorized administrator of Scholarly Commons. For more information, please contact commons@erau.edu.

Presenter Information

R. Glenn Sellar, Rolando Branly, Adam I. Ayala, Patrick L. Bertiaux, David S. Desrochers, Christopher J. Girard, David C. Johnson, Andrew P. Mayer, Chae Ku O, and Ron Schaub

High-Efficiency HyperSpectral Imager for the Terrestrial and Atmospheric MultiSpectral Explorer

R. Glenn Sellar^a, Rolando Branly^b, Adam I. Ayala^a, Patrick L. Bertiaux^a, David S. Desrochers^a, Christopher J. Girard^a, David C. Johnson^a, Andrew P. Mayer^a, Chae Ku O^a, and Ron Schaub^c

^aFlorida Space Institute, MS: FSI, Kennedy Space Center, FL 32899, gsellar@mail.ucf.edu

^bBroward Community College

^cDynamac Corporation

1 Abstract

The Terrestrial and Atmospheric MultiSpectral Explorer¹ (TAMSE) is a Space Shuttle Small Self-Contained Payload “Get-Away Special” (GAS) project, led by Principal Investigator Rolando Branly, and including remote sensing and microgravity experiments from Florida Space Institute member schools. One of these experiments is the High-Efficiency HyperSpectral Imager (HEHSI). The HEHSI project will provide a low-cost spaceflight demonstration of a novel type of imaging spectrometer with exceptional light gathering ability. HEHSI is also a demonstration of what can be achieved in space with a modest budget: \$ 15K from the Florida Space Grant Consortium (FSGC) and \$ 10K from the Florida Space Institute (FSI). Education and workforce development are important goals of the project, with all of the mechanical, electronics, and software design and testing being carried out by an interdisciplinary team of FSI students. These six students, who are about to graduate with bachelor’s degrees in engineering (three computer, one electrical, and two aerospace), have worked on the project and received course credit for two semesters. The matching funds from FSI support the involvement of the mentor for the HEHSI experiment, Glenn Sellar, who is also responsible for the optical design. Environmental testing (thermal and vibration) will be carried out by the students at KSC’s Physical Testing Laboratory, under a cooperative Space Act Agreement. As this instrument is the first remote sensing payload constructed in Florida (to the authors knowledge), it also serves as a seed for diversification of the space industry in Florida. An overview of the project is presented in this paper, including the science objectives, and the optical, mechanical, electrical, and software designs.

2 Objectives

Forecasts vary, but remote sensing seems poised to become the next commercially profitable segment of the space industry. One of the drivers for this development is the exciting range of potential applications for *hyperspectral imagery* (imagery in >30 spectral bands). The first successes for spaceborne hyperspectral imagers were achieved just last year, including the Fourier Transform HyperSpectral Imager (FTHSI) on the Air Force’s MightySat II spacecraft^{2,3}. FTHSI, which was constructed by the Kestrel Corporation in New Mexico based on an optical design by Glenn Sellar of FSI, was the very first hyperspectral imager to demonstrate successful operation in orbit.

But the FTHSI and its brethren are seriously limited in their light-gathering ability. These instruments rely either on a spatially narrow slit or on a spectrally narrow filter to obtain spectral resolution. This slit or filter blocks typically ~99% of the available light and thus places a serious limitation on the signal-to-noise ratio that can be achieved. Since a low earth orbiting spacecraft is moving at roughly 7 km/s, the ability to lengthen the exposure time to make up for the poor efficiency is very limited.

The HEHSI design is based on a concept demonstrated in the laboratory by Slough and Rafert, which requires neither a slit nor a bandpass filter⁴, and thus possesses an exceptional light-gathering ability. This advantage is expected to allow HEHSI to achieve a signal-to-noise ratio (SNR) on the order of 5000, with a ground sample distance (GSD) of approximately 60 m across a swath width of 40 km, in 60 spectral bands in the visible and near infrared.

3 Applied Demonstration for Wildland Fire Management

With the Shuttle manifest largely occupied with construction of the International Space Station, the HEHSI instrument is expected to be completed well before a Shuttle flight opportunity becomes available. In the interim, funding is being sought for an effort to use the completed HEHSI for applied testing in support of wildfire research efforts at the Kennedy Space Center (KSC) and Cape Canaveral Air Force Station (CCAFS). Such a laboratory and field-based effort would serve three objectives:

- 1) Thoroughly validate the operation of the HEHSI instrument;
- 2) Demonstrate the ability of the instrument and the processing and analysis techniques to provide data that is useful for remote sensing applications; and
- 3) Support research at the KSC/CCAFS in remote sensing techniques for characterizing wildland fuels and predicting the probability of wildfire ignition.

Scientists from the Ecological Program of the Life Science Support Contract at KSC (currently held by the Dynamac Corporation) would work on this phase with the PI and students to demonstrate the functional capabilities of the HEHSI in controlled investigations of plant canopy moisture. Application of remote sensing techniques toward management of wildland fuel and fire has received considerable interest and support. A key element required to predict the potential and threat of wildland fire is plant (fuel) moisture content. Ignition, flame front rate of spread, and intensity are all influenced by moisture levels. Remote sensing offers the capability to effectively characterize large regions with great efficiency, which would be a considerable benefit to land managers involved in wildland fire management.

Fuel moisture content can be estimated from recent weather patterns⁵. However, weather data is often acquired from isolated point stations requiring a great degree of interpolation between points. Plant reflectance characteristics may be influenced by plant water content^{6,7,8}. Therefore, a high-resolution imaging system capable of estimating fuel moisture at both landscape and regional scales is required.

Detailed descriptions of fuel properties provide a quantitative basis for rating fire danger⁹. Characterizing fuels and fire potential with spaceborne systems will support landscape management efforts and emergency response to wildfire events. The HEHSI instrument could be applied to this problem with the goal of producing images that can be readily interpreted to produce high-resolution plant moisture maps.

4 Design

4.1 Environmental Constraints

The primary environmental constraints for a Space Shuttle GAS payload are the vibration and static loads experienced at launch, and the temperature extremes experienced on orbit. Vibration levels are expected to be approximately 3.5 G rms, and temperatures may eventually reach extremes of $\pm 100^{\circ}\text{C}$. The GAS canister is pressurized with nitrogen, so vacuum compatibility is not a issue. Radiation is only a minor concern, since the orbit is low, the GAS canister provides shielding, and the mission duration is relatively short (a few days).

4.2 Optical Design

The heart of the HEHSI design is a Sagnac interferometer. The Sagnac is a two-beam, common-triangular-path interferometer, shown in Figure 1.

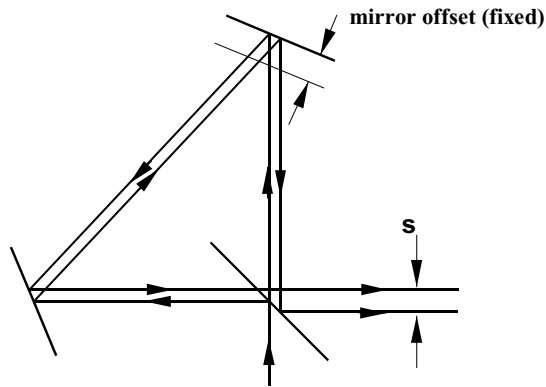

Figure 1: Sagnac interferometer

One beam transits the interferometer in a clockwise direction, while the other transits the same path in a counterclockwise direction. If the two mirrors were placed symmetrically with respect to the beam splitter, then the two rays would exit the interferometer in the same direction and at the same position. If one mirror is offset from a symmetric position, however, then the two rays exit in the same direction, but at positions symmetrically offset from the optical axis by a distance $s/2$. The path difference through the interferometer is a function of the angle of the ray entering the interferometer, but does not vary with the position of entry. The interferogram (fringe pattern) is localized at infinity, so a lens – referred to as the Fourier lens – is used to image the fringes onto the detector array. The modulus of the Fourier transform of this interferogram gives the spectrum of the source.

Figure 2 shows the complete optical design, including the Fourier lens. The optics consist entirely of commercial-off-the-shelf (COTS) components, with a total cost of \$ 1743.

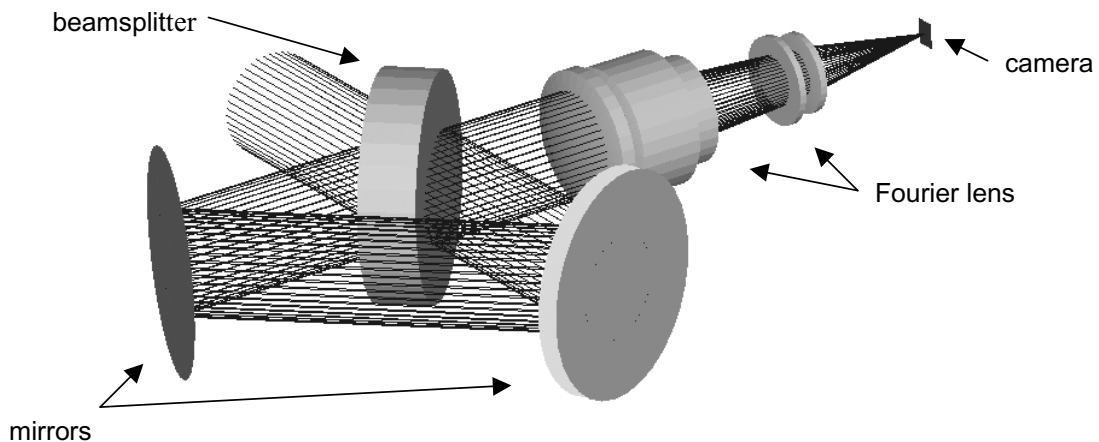

Figure 2: HEHSI optical design

4.3 Electronics and Software Design

The purpose of electronics and flight software is to acquire and store the digital image data. The hardware consists of a digital CCD video camera, a camera interface card (CIC), mainboard (CPU), backplane and data storage (hard drive), as depicted in Figure 3.

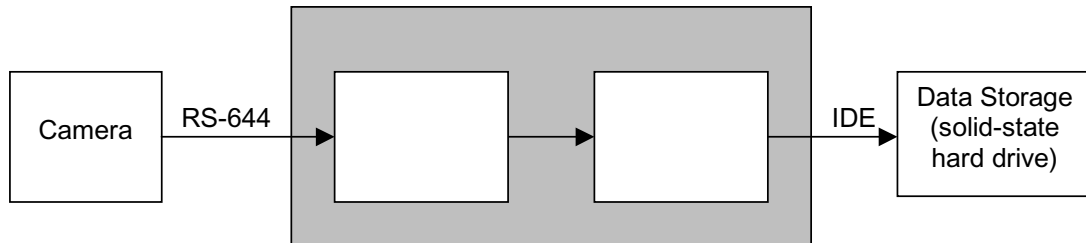

Figure 3: Electronics block diagram

4.3.1 Environmental Tolerances

With a total budget of only \$ 15K, it is not possible to achieve an operational temperature range of -100°C to $+100^{\circ}\text{C}$ for the electronics. These temperatures, however, are the extremes that may be reached only if the Shuttle attitude has the payload bay towards the sun or continuously in shade for a period of days. Temperatures in the GAS canister near the beginning of the mission are expected to be much less extreme. Thus, the electronics have been selected for the maximum operational temperature ranges that can be achieved within the budget. Special emphasis on temperature tolerance has been applied to the solid-state hard drive, which records the data and must survive the entire mission with the data intact. Industrial computer components provide temperature tolerances that, while not as broad as systems designed for space, are much broader than those for desktop or even portable applications. Vibration and shock tolerances of industrial components are also appropriate for this application.

The cost of radiation-hardened components would exceed the budget; but since the orbit is low, the GAS canister provides shielding, the mission is relatively short, and the instrument needs to be in operation for only a few minutes, this is not a major concern. The system design includes a watchdog timer that will reboot the system if a latchup occurs, and the software has been designed to be as fault tolerant as possible.

4.3.2 Form Factor and Backplane

The selected form factor for the computer system was driven by the environmental requirements and by the availability of digital camera interface cards. Form factors for rugged industrial applications include *PC-104* and *Compact PCI* (or *cPCI* or *PXI*), but digital camera interface cards are currently available only for Compact PCI. The selected backplane has been purchased from Kaparel, and accommodates two cPCI or PXI boards.

4.3.3 Camera

The selection of the camera is a major driver on the design of the electronics system. The requirement was for a monochrome, progressive-scan camera with a frame rate of at least 100 frames/s (due to the 7 km/s orbital velocity), a minimum spatial resolution of 256 x 256 pixels, digital output with a radiometric resolution of at least 8-bits, broad operational temperature range, rugged vibration and shock tolerance, and a cost less than \$ 3K.

The selected camera is the Pulnix TM-6710. This is a progressive-scan digital CCD camera providing frame rates of 120 or 240 frames/s. It provides a digital output with 8-bit resolution, conforming to the RS-644 Low Voltage Differential Signal (LVDS) standard. The resolution is 648 x 484 pixels. It is rated to survive 7 G rms random vibration and has an operating temperature range of -10° to $+50^{\circ}$ C.

4.3.4 Camera Interface Card

The selection of the camera interface card (CIC) was driven primarily by the selection of the camera, and also by environmental and cost constraints. The selected CIC is National Instruments' PXI-1422, which is a PXI camera interface card compatible with the Pulnix-6710 camera. The environmental tolerances of PXI-1422 are comparable to the other components of the system. The operating temperature range is 0° to $+50^{\circ}$ C and the storage temperature is -25° to $+70^{\circ}$ C.

4.3.5 Mainboard

A primary requirement for the mainboard is the capacity to store in memory a single full data-set (or *data-cube*) received from the camera at ~ 30 MB/s, before transferring the data-set to non-volatile storage (the solid-state hard drive) at a much slower data rate. The PEP CP302 mainboard was selected to meet this requirement. The CP302 includes a 650 MHz mobile Pentium III processor and a 16 MB 'disk-on-chip' (which will hold the operating system software). This is the only rugged cPCI board available that supports the required 384 MB of RAM. The extended temperature range option for this board provides excellent thermal tolerances: an operational range of -40° to $+85^{\circ}$ C, and a storage range of -55° to $+95^{\circ}$ C.

4.3.6 Data Storage

In order to ensure that the data acquired will survive the mission, a solid-state (*Flash RAM*) hard drive will be used. Such drives have no moving parts and can withstand random vibration up to 20 G and temperatures from -80° to $+80^{\circ}$ C. At the time of writing, the specific hard drive has not yet been selected, because this will be constrained by the funds remaining after the rest of the system is completed. It is desirable to use the largest capacity drive that can be afforded, since this determines the number of scenes (referred to as *data-cubes*) that can be returned from orbit for analysis. Also, since the cost-per-megabyte decreases with time, this purchase should be delayed as long as feasible. It is expected that the drive will likely hold between 0.4 – 2 GB of data, and accept a transfer rate of approximately 1 MB/s.

4.3.7 Flight Software

The selection of operating system was driven primarily by the driver software available for the selected components, and also by the desire to use as little memory as possible. Windows NT Embedded has been selected to meet these requirements. A batch file will control the data acquisition sequence. The only control input available is one dual-throw relay that will be controlled by an astronaut on the Shuttle flight deck. This relay will be used to power up the computer and initiate the batch file when the Shuttle is in the desired location and attitude for acquisition of a scene.

4.3.8 Data Processing Software

The ground processing software is responsible for concatenating the acquired image frames from the camera into a hyperspectral *data-cube*: a three-dimensional array of spatial and spectral information. This procedure consists of three processes: decompression of the data, error correction, and application of the Fourier transform. This application has been written in Visual C++ utilizing Image & Signal Processing Libraries. It will reside on a PC on the ground to which the images gathered will be

transferred after the flight. One complete raw data-cube consists of 928 frames of 648 x 484 pixels each. Since the Shuttle attitude may not be ideally oriented with respect to the ground and the instrument field of view, and since the orbital velocity will not be ideally matched to the frame rate provided by the camera, the ground software has been designed correct for this non-ideal velocity vector. After this correction is performed, the application of a Fourier transform translates the path difference information in the interferogram into spectral information (wavelength). The result is a hyperspectral data-cube: a data set that consists of reflected radiance (brightness) as a function of X (cross-track position), Y (along-track position), and λ (wavelength). A visualization of a hyperspectral data-cube is shown in Figure 4.

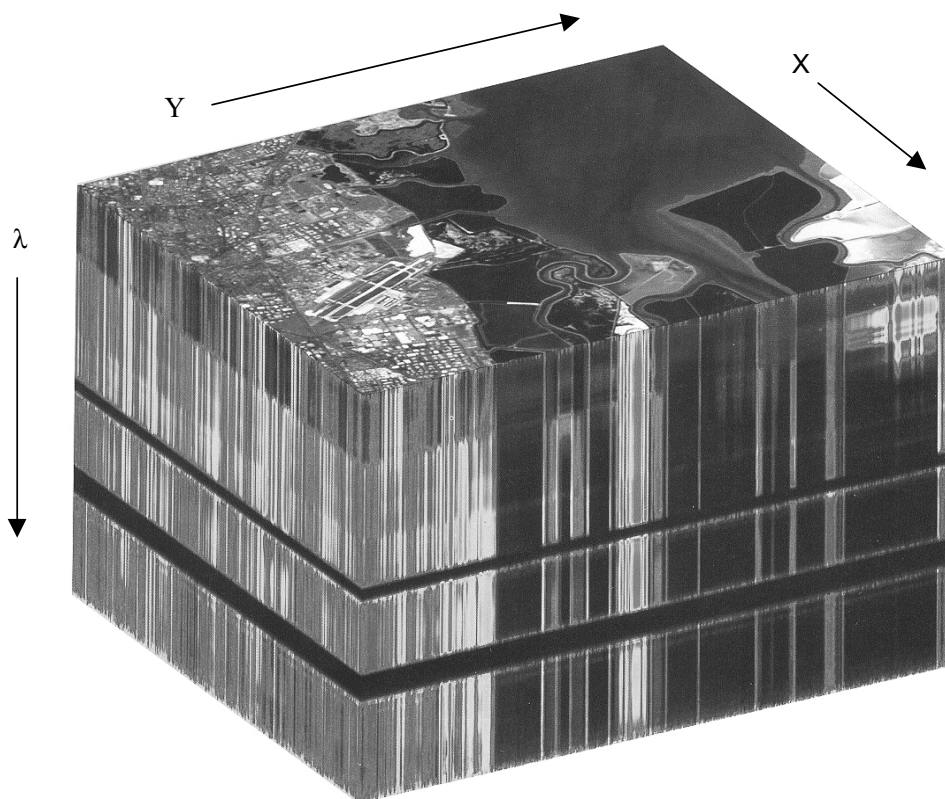

Figure 4: Hyperspectral data-cube (courtesy of NASA/JPL)

4.4 Mechanical Design

The mechanical structures for HEHSI have been designed to preserve structural integrity, support the electronics system, and maintain alignment of the optical components. The arrangement of the internal components can be seen in Figure 5, which shows HEHSI mounted to the TAMSE payload structure. Light enters through an aperture in the circular top plate, passes through an optical baffle, then the interferometer, and finally the Fourier lens which focuses it on the camera.

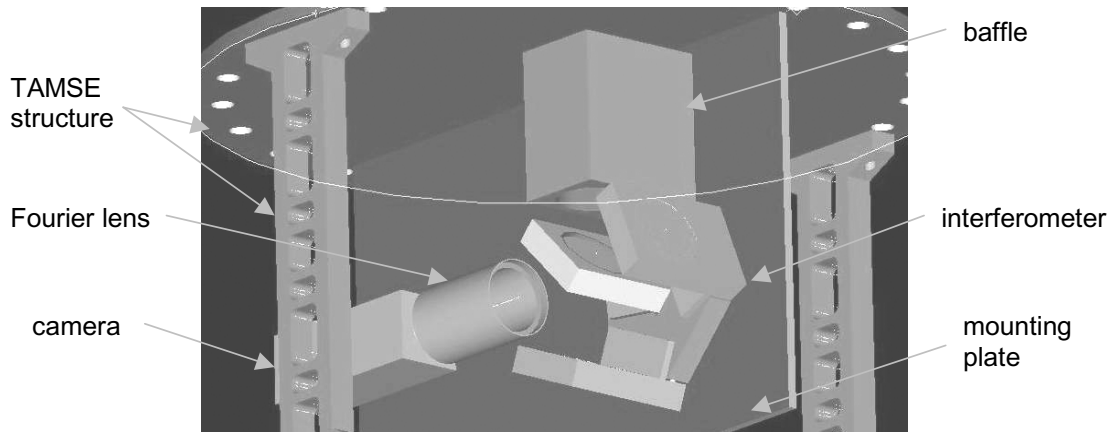

Figure 5: HEHSI installed in TAMSE

An aluminum plate provides the mounting surface for these assemblies. An angular tolerance $\pm 0.1^\circ$ must be maintained between the interferometer and the camera & lens assembly.

The optical baffle is designed to block stray light from outside the field of view from entering the rest of the system. Within the baffle assembly are a series of fins (baffles) with circular apertures, designed to trap light that enters from angles outside the field of view.

Tolerances within the interferometer are considerably tighter than the tolerances between the assemblies. For example, the angles between the beamsplitter and mirrors must be held within $\pm 0.01^\circ$. To achieve these tight tolerances over the wide temperature range, the interferometer is based on a mounting plate made of *Invar* alloy (material donated by Egret Systems), which has a coefficient of thermal expansion (CTE) only $1/50^{\text{th}}$ that of aluminum. This low CTE enables the plate to maintain the spacing between the components. The mounts for the optics are constructed of aluminum 6061-T6 for ease of machining. Figure 6 shows the interferometer assembly.

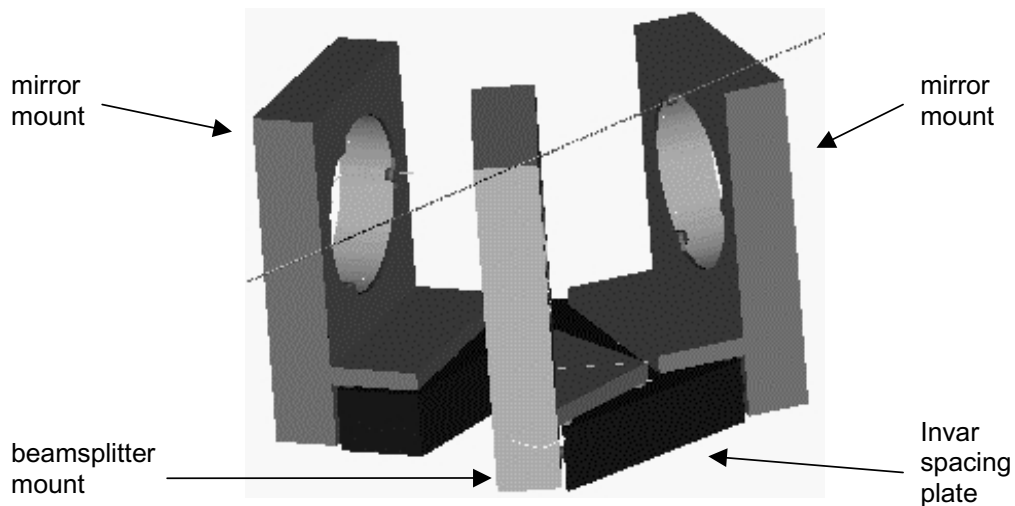

Figure 6: Interferometer assembly

The beamsplitter and the two mirrors are each held in the mounts by compression gaskets on the backside and three contact pads contacting on the front surface. The mounts contact the Invar chassis on five contact pads and are bolted down to hold the pads in contact. Exploded views of the optics and mounts are shown in Figure 7.

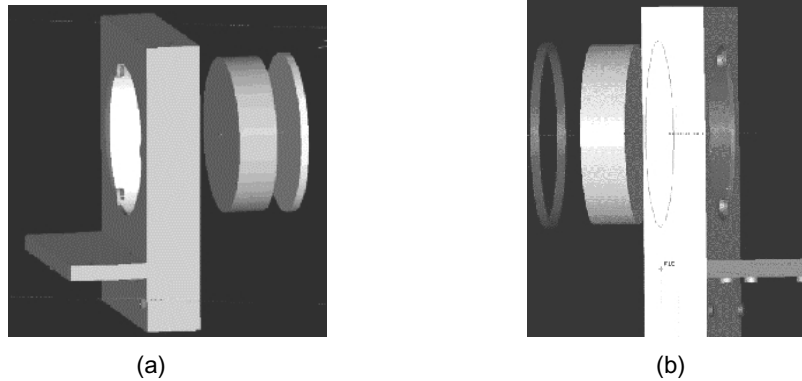

Figure 7: (a) Beamsplitter and mount, (b) mirror and mount (1 of 2)

References

- ¹ J. M. Ritter, R. Branly, E. Ackerman, R. Friedfeld, J. Bickham, A. Blitz, J. Feranda, C. Dahl, C. Theodorakis, "An Interdisciplinary Payload to Perform Space Based Remote Sensing and to Measure Microgravity and Radiation Effects", *Symposium of the Association of Small Payload Researchers* (1997).
- ² L. J. Otten, J. B. Rafert, A. Meigs, B. Jones, R. Prinzing, R. Fronterhouse, R. G. Sellar, and P. Hodge, "The Engineering Model for the MightySat II.1 Hyperspectral Imager," *Sensors, Systems, and Next-Generation Satellites, SPIE Proceedings*, **3221**, 412-420, (Dec. 1997).
- ³ L. J. Otten, A.D. Meigs, F. P. Portigal, B. A. Jones, R. G. Sellar, D. C. Fronterhouse, J. B. Rafert, J. R. O'Hair, T.S. Turner, "MightySat II.1: an optical design and performance update", *Advanced and Next-Generation Satellites II, SPIE Proceedings*, **2957**, 390-398, (Jan. 1997).
- ⁴ W. J. Slough, J. B. Rafert, C. A. Rohde, C. L. Hart, "THRIFTI: Tomographic hyperspectral remote imaging Fourier transform interferometer", *Digitization of the Battlespace III, SPIE Proceedings* **3393**, 207-216 (1998).
- ⁵ C. Rothermel, R. Wilson Jr., G. Morris, S. Sackett, and S. Stephen, "Modeling moisture content of fine dead wildland fuels: input to the BEHAVE fire prediction system", Res. Pap. INT-359, Ogden, UT: U.S. Dept. of Agriculture, Forest Service, Intermountain Research Station, pp. 61 (1986).
- ⁶ L. Grant, "Diffuse and specular characteristics of leaf reflectance", *Remote Sensing of the Environment* **22**, 309-322, (1987).
- ⁷ W. Bowman, "The relationship between leaf water status, gas exchange and spectral reflectance in cotton leaves", *Remote Sensing of the Environment* **30**, 249-255, (1992).
- ⁸ R. Hunt Jr. and B. Rock, "Detection of changes on leaf water content using near- and middle- infrared reflectances", *Remote Sensing of the Environment* **30**, 43-54, (1989).
- ⁹ H. Anderson, "Aids to determining fuel models for estimating fire behavior", *USDA For. Serv. Gen. Tech. Rep.* INT-122, pp. 22 (1982).