

9-1-1979

## Traffic Noise Regulation: A Comparative Study

Stephen G. Wood

Follow this and additional works at: <https://digitalcommons.law.byu.edu/lawreview>

 Part of the [Environmental Law Commons](#), and the [State and Local Government Law Commons](#)

---

### Recommended Citation

Stephen G. Wood, *Traffic Noise Regulation: A Comparative Study*, 1979 BYU L. Rev. 461 (1979).

Available at: <https://digitalcommons.law.byu.edu/lawreview/vol1979/iss3/2>

This Article is brought to you for free and open access by the Brigham Young University Law Review at BYU Law Digital Commons. It has been accepted for inclusion in BYU Law Review by an authorized editor of BYU Law Digital Commons. For more information, please contact [hunterlawlibrary@byu.edu](mailto:hunterlawlibrary@byu.edu).

# Traffic Noise Regulation: A Comparative Study†

*Stephen G. Wood\**

## Summary of Contents

I.	Introduction	465
A.	Why Study Noise?	468
B.	Why Study Traffic Noise?	477
	1. Ever-increasing vehicle traffic	477
	2. Factors affecting traffic noise emissions	481
	a. Speed of motor vehicle	481
	b. Type of motor vehicle	482
	c. Age of motor vehicle	484
	d. Weather conditions	484
	e. Time of day	484
	f. Traffic flow	484
	g. Traffic density	485
	h. Natural and manmade environment	485
C.	How Can Traffic Noise be Regulated?	487
	1. Regulation techniques	487
	a. Source modification	487
	b. Operational modification	488
	c. Transmission path modification	488
	d. Architectural modification	489
	2. Modification options	490
	a. Direct regulation	490
	b. Direct intervention	490

---

† This Article was written in partial fulfillment of the requirements for the degree of Doctor of the Science of Law in the Faculty of Law, Columbia University.

The author wishes to express his appreciation to Professor Charles Szladits who originally suggested the topic of noise to the author and to the members of his dissertation committee—Professor Frank P. Grad, chairman; Professor, now Dean Albert J. Rosenthal; Professor Charles Szladits, and Professor Alfred Hill—who carefully read and thoughtfully criticized earlier drafts.

The author also wishes to express his appreciation to officials at all three levels of government in the United States and the Federal Republic of Germany and the European Community Information Service in Washington, D.C., for their assistance.

All translations from German source material are by the author.

\* Professor of Law and Associate Dean, J. Reuben Clark Law School, Brigham Young University. J.D., 1969, University of Utah. Jervy Fellow in Foreign and Comparative Law, 1969-1970, Columbia University; Ludwig Maximilien Universität, 1970-1971, Munich, W. Germany.

	c. Subsidies .....	491
	d. Financial incentives .....	491
	e. Self-regulation .....	491
II.	Regulation of Traffic Noise in the United States .....	493
	A. Noise Control Act of 1972 .....	494
	1. Noise emission standards .....	495
	a. Section 5 .....	495
	b. Section 6: regulation of noise sources .....	499
	c. Section 6: preemption problems .....	503
	d. Section 18 .....	507
	e. Section 18: Motor Carrier and Motor Carrier Compliance Regulations .....	510
	Motor Carrier Regulations .....	510
	Motor Carrier Compliance Regulations .....	516
	f. Section 6: New Truck Regulations .....	528
	g. Other section 6 regulations .....	556
	2. Product noise labels .....	561
	3. Acquisition of products .....	565
	4. Federal assistance .....	571
	5. Enforcement of the NCA .....	576
	B. Federal-Aid Highway Act .....	582
	1. Provisions of the Act .....	582
	2. Enforcement of the FAHWA .....	598
III.	Regulation of Traffic Noise in New York State .....	601
	A. Vehicle and Traffic Law .....	601
	1. Noise provisions .....	601
	a. Vehicle muffler provisions .....	601
	b. Noise emission standards provision .....	604
	2. Enforcement of the Vehicle and Traffic Law .....	609
	B. Environmental Conservation Law .....	613
	1. Noise provisions .....	613
	a. Articles 1, 3, 5, and 7 .....	613
	b. Air Pollution Control Act .....	615
	2. Enforcement of the ECL .....	617
IV.	Regulation of Traffic Noise in New York City .....	621
	A. Overview of Attempts to Control Noise in New York City .....	621
	1. Noise regulation committees .....	621
	2. Regulation prior to 1972 .....	624
	B. The Noise Control Code of 1972 .....	626
	1. Code provisions .....	626
	a. Articles III and IV .....	627
	b. Article V .....	628
	c. Article VI .....	633
	2. Enforcement .....	635
	3. Evaluation of the code and its enforcement .....	640

V.	Regulation of Traffic Noise in the Federal Republic of Germany	643
A.	Phase One: General Laws	644
	1. Civil Code provisions	644
	2. Penal Code provisions	645
B.	Phase Two: Noise Emission Standards	647
	1. Motor Vehicle Law (StVG)	653
	2. Motor Vehicle Ordinance (StVO)	655
	3. Motor Vehicle Approval Ordinance (StVZO)	660
	4. Muffler Replacement Regulations	680
	5. Other noise emission guidelines, directives, and amendments	680
	6. Guidelines Governing Traffic Measures to Protect Sleep	692
	a. Traffic prohibitions	693
	b. Traffic limitations for particular types of motor vehicles	694
	c. Shifts in traffic	694
	d. Detours	694
	e. Traffic speed limitations	695
	f. The "green wave"	695
	g. Traffic signs	695
C.	Phase Three: Ambient Noise Level Standards	698
	1. General legislation	703
	a. Zoning Law (ROG)	703
	b. Federal Building Law (BBauG)	703
	c. Building Use Regulations (BauNVO)	704
	d. Federal Highway Law (FStrG)	704
	2. Specific legislation: Federal Ambient Levels Protection Law (BImSchG)	708
D.	Enforcement	713
VI.	Regulation of Traffic Noise in Bavaria	717
A.	Important Resolutions and Related Matters	719
B.	Laws and Related Matters	728
	1. Source measures	729
	2. Operational measures	729
	3. Building measures	729
	4. Highway measures	732
C.	Enforcement	745
VII.	Regulation of Traffic Noise in Munich	747
A.	The Law	747
B.	The Reports	748
	1. The 1962 Report	748
	2. The 1968 Overview Report	750
	3. The 1968 Urban Noise Report	753
	4. The 1970 Report	754
	5. The 1971 Report	756



	6. The 1974 Report .....	760
	7. The 1977 Report .....	767
VIII.	Conclusion .....	771
	A. Deficiencies in Existing Regulatory Schemes .....	771
	B. The Enforcement Problem .....	783
	1. Division of federal and state responsibilities .....	783
	2. An effective enforcement strategy for state and local governments .....	786
	a. Enactment of a modern noise law .....	786
	b. Use controls .....	792
	Prohibiting the use of horns, bells, and sirens .....	792
	Lowering speed limits .....	793
	Synchronizing traffic lights .....	794
	Regulating commercial traffic .....	795
	Rerouting motor vehicles .....	795
	Limiting the use of a highway .....	795
	Prohibiting the use of a highway .....	796
	c. Transmission path modification .....	797
	Evaluating noise in the highway planning process .....	797
	Maintaining separation of highways and places where people live, work, or play .....	800
	Using zoning .....	801
	Using the natural or manmade environment .....	802
	d. Architectural modifications .....	803
	e. Procurement program .....	805
	f. Education program .....	806

## SECTION I

### INTRODUCTION

A comparative study presupposes that the entities to be compared exhibit both similarities and differences. This comparative study, which describes and analyzes the legal efforts to regulate traffic noise made by the United States and the Federal Republic of Germany at the federal, state,<sup>1</sup> and local<sup>2</sup> levels, highlights the alternative means employed by two societies to solve a common problem.

These two societies exhibit significant differences. The land area of the United States is 3.6 million square miles/9.4 million square kilometers;<sup>3</sup> the land area of the Federal Republic of Germany is 95,976 square miles/249,538 square kilometers.<sup>4</sup> The population of the United States, which was 217.7 million in 1977, is expanding and heterogeneous;<sup>5</sup> the population of the Federal Republic of Germany, which was 61.4 million in 1977, appears to be holding fairly constant at that figure and is far more homogeneous.<sup>6</sup>

The two societies also exhibit significant similarities. Both are industrial and urban. Both continue to have a "love affair" with motor vehicles in general and automobiles in particular. Table I-1<sup>7</sup> shows the number of automobiles for every 1000 people in the United States and the Federal Republic of Germany.

---

1. New York State and Bavaria illustrate the efforts of state governments.

2. New York City and Munich illustrate the efforts of local governments.

3. THE WORLD ALMANAC AND BOOK OF FACTS 207 (1979).

4. *Id.* at 538.

5. *Id.* at 205.

6. *Id.* at 538.

7. Table I-1 is based on information collected by the United States Federal Highway Administration and the Kraftfahrt-Bundesamt (Federal Office of Motor Vehicles) of the Federal Republic of Germany and supplied to the author.

The number of automobiles in the United States and the Federal Republic of Germany has continued to increase throughout the period 1955-1978. In contrast to the increasing population in the United States, the population of the Federal Republic of Germany peaked in 1973 at 62.1 million and has declined slightly since that time, stabilizing at 61.4 million in 1976.

As a result of these developments, the ratio of automobiles/1000 population in the United States to automobiles/1000 population in the Federal Republic of Germany has narrowed from 9.8 in 1955 (314:32) to 1.6 in 1977 (526:326).

TABLE I-1

Year	Population (millions)		Automobiles (millions)		Automobiles/ 1,000 population	
	U.S.	F.R.G.	U.S.	F.R.G.	U.S.	F.R.G.
1955	165.9	52.4	52.1	1.7	314	32
1960	180.7	55.4	61.7	4.5	341	81
1965	194.3	58.7	75.2	9.3	387	158
1970	204.7	60.6	89.2	13.9	435	229
1971	207.1	61.3	92.7	15.1	447	246
1972	208.8	61.7	97.1	16.1	465	261
1973	210.4	62.1	102.0	17.0	485	274
1974	211.9	62.0	104.9	17.3	495	281
1975	213.6	61.6	106.7	17.9	500	291
1976	215.1	61.4	110.4	18.9	513	308
1977	216.8	61.4	113.7	20.0	524	326
1978	218.7	61.3	116.6	21.2	533	346

Table I-2<sup>8</sup> shows the number of motor vehicle miles traveled per person in the United States and the Federal Republic of Germany.

8. Table I-2 is based on information collected by the United States Federal Highway Administration and the Kraftfahrt-Bundesamt (Federal Office of Motor Vehicles) of the Federal Republic of Germany and supplied to the author.

Note that both total travel and total travel per person dipped in 1974 as a result of the "energy crisis," but rebounded in 1975. Indeed, the 1975 levels exceeded the 1973 levels.

TABLE I-2

Year	Population (millions)		Total Travel (billions)		Average Miles Traveled/Person	
	U.S.	F.R.G.	U.S.	F.R.G.	U.S.	F.R.G.
1955	165.9	52.4	603.4	na	3,637.1	na
1960	180.7	55.4	718.8	67.7	3,977.9	1,222.0
1965	194.3	58.7	887.6	107.2	4,568.2	1,826.2
1970	204.7	60.6	1,120.7	143.8	5,474.8	2,372.9
1971	207.1	61.3	1,186.3	152.2	5,728.2	2,482.9
1972	208.8	61.7	1,268.3	157.0	6,074.2	2,544.6
1973	210.4	62.1	1,308.6	163.6	6,219.6	2,634.5
1974	211.9	62.0	1,285.6	160.6	6,067.0	2,590.3
1975	213.6	61.6	1,330.1	171.5	6,227.1	2,784.1
1976	215.1	61.4	1,411.9	178.3	6,563.9	2,904.0
1977	216.8	61.4	1,476.6	185.1	6,810.9	3,014.7
1978	218.7	61.3	1,548.2	194.3	7,079.1	3,169.7

Table I-1 and I-2 demonstrate that traffic noise is an integral part of the environmental landscape in both America and Germany.

In regulating traffic noise, government can use at least five techniques,<sup>9</sup> grouped into four categories.<sup>10</sup> No two of the six governments examined in this comparative study—two federal, two state, and two local—have chosen the same noise control program. Each has chosen its own unique mix of techniques within the four categories. This comparative study's value lies in its assessment of the effectiveness of these six noise control programs.

The federal government in Germany has been regulating noise for most of this century. Noise laws, consequently, have passed or are passing through three different but overlapping phases: (1) a "general" laws phase, (2) a noise emission standards phase, and (3) an ambient noise level standards phase. Under this evolving system of regulation, the German federal government has assumed the major responsibility for both noise emission

9. The five techniques are direct regulation, direct intervention, subsidies, financial incentives, and self-regulation. See notes 102-09 and accompanying text *infra*.

10. The four categories are source modification, operational modification, transmission path modification, and architectural modification. See notes 90-101 and accompanying text *infra*.

standards and ambient noise level standards. State and local governments play a minor role.

In contrast, the federal government in the United States has been regulating noise only since the early 1970's. The American federal government has chosen to establish noise emission standards, leaving ambient noise level standards to state and local governments. Under this system of regulation, state and local governments in the United States theoretically have more options available to them than their German counterparts.

In determining the best allocation of responsibilities between the three levels of government, several questions arise. Should the federal government confine itself to noise emission standards? Are state and local governments in the United States capable of establishing ambient noise level standards? On which noise control techniques can the available financial resources best be spent?

This comparative study addresses the allocation of responsibility question and notes some of the deficiencies in existing regulatory schemes.<sup>11</sup> An enforcement strategy is outlined in a portion of the concluding chapter.<sup>12</sup>

Before turning to those matters, however, several questions raised by a comparative study of traffic noise regulation need to be answered: Why study noise? Why study traffic noise? And finally, what regulatory options are available?

#### A. *Why Study Noise?*

Noise regulation is the stepchild of the environmental movement in the United States.<sup>13</sup> Although the impact of noise on the

---

11. See Section VIII-A *infra*.

12. See Section VIII-B *infra*.

13. Table A shows capital investment on environmental quality control in the United States in 1970.

## A

Pollutant	Capital Invest- ment in Place (billions of dollars)	Percentage of Total Capital Investment	Annual Capital Investment (billions of dollars)	Percentage of Total Capital Investment
Air pollution	1.5	6.1	1.0	27.8
Water pollution	23.3	93.9	2.5	69.4
Solid waste	na	na	0.1	2.8
Other (noise, radiation, land reclamation)	0	0	0	0
1970 TOTAL	24.8	100	3.6	100

G. BUGLIARELLO, A. ALEXANDRE, J. BARNES & C. WAKSTEIN, *THE IMPACT OF NOISE POLLUTION: A SOCIO-TECHNOLOGICAL INTRODUCTION 6* (1976) [hereinafter cited as *NOISE POLLUTION IMPACT*].

Table B shows what all levels of government in the United States spent on environmental quality control in 1976.

## B

Pollutant	Amount Spent (billions of dollars)
Water pollution	7.0
Solid waste (street cleaning, garbage collection, highway litter removal)	2.5
Air pollution	0.376
Other (noise, administrative operations)	0.324
<b>TOTAL</b>	<b>10.2</b>

Wall St. Journal, Mar. 20, 1978, at 16, col. 6.

Between 1972 and 1976, the amount spent on environmental quality control nearly doubled from \$5.5 billion to \$10.2 billion. The amount spent by all levels of government in 1976 was 14.4% higher than in 1975. "Federal spending rose 28% to \$3.7 billion . . . . State spending rose 27% to \$1.3 billion [and local spending rose 12% to \$8.6 billion]." *Id.*

Table C shows projected capital investment on environmental quality control in the United States in 1980.

quality of life can be devastating, other environmental concerns have been given higher priority.<sup>14</sup> One reason for this situation is that noise cannot be defined with the precision and clarity with which other environmental concerns can be.

In order to define noise, sound must first be defined. Sound can be measured objectively in terms of three variables: intensity,<sup>15</sup> frequency,<sup>16</sup> and duration.<sup>17</sup> Of these three variables, the

## C

Pollutant	Capital Investment in Place (billions of dollars)	Percentage of Total Capital Investment	Annual Capital Investment (billions of dollars)	Percentage of Total Capital Investment
Air pollution	29.8	38.7	6.0	63.2
Water pollution	46.1	59.7	3.0	31.5
Solid waste	na	na	0.3	3.2
Other (noise, radiation, land reclamation)	1.2	1.6	0.2	2.1
Projected 1980 TOTAL	77.1	100	9.5	100

NOISE POLLUTION IMPACT, *supra*, at 6.

Tables A and C indicate not only a high commitment in America to fighting air and water pollution but also what has been described as an "insignificant" American commitment to the problems of noise and other sources of pollution. *Id.* at 5.

14. Noise regulation, however, does not pose an "either-or" situation because efforts to control noise are compatible with efforts to control other environmental concerns. Noise control and air pollution control usually are mutually reinforcing. "For example, while converting noxious fumes into innocuous gases, a catalytic muffler, by filtering the exhaust, will at the same time assist the regular muffler." F. GRAD, A. ROSENTHAL, L. ROCKETT, J. FAY, J. HEYWOOD, J. KAIN, G. INGRAM, D. HARRISON & T. TIETENBERG, *THE AUTOMOBILE AND THE REGULATION OF ITS IMPACT ON THE ENVIRONMENT* 444 (1975) [hereinafter cited as GRAD & ROSENTHAL].

15. Intensity is a measure of sound pressure and is expressed in terms of decibels (dB), "a measure, on a logarithmic scale, of the magnitude of a particular quantity [of sound] with respect to a standard reference value." U.S. ENVIRONMENTAL PROTECTION AGENCY, *REPORT TO THE PRESIDENT AND CONGRESS ON NOISE*, S. DOC. NO. 63, 92nd Cong., 2d Sess. G-4 (1972) [hereinafter cited as SENATE DOCUMENT 63]. Since the decibel scale is logarithmic, a minor increase or decrease results in a disproportionate impact. An increase of 10 dB, for example, is an increase of 100%. Conversely, a decrease of 2 dB is a decrease of 20%.

16. Frequency is a measure of pitch and is expressed in terms of Hertz (Hz) or cycles per second (cps). The higher the pitch, the greater the number of complete oscillations or cycles per second.

17. Duration is a measure of the time the sound lasts and is expressed in terms of seconds.

most important is intensity, which is relatively easier to measure than frequency.<sup>18</sup> Sound can also be defined subjectively in terms of an individual's reaction to the sound. Table I-3<sup>19</sup> illustrates the sound spectrum.

---

18. The human ear is more sensitive to higher frequencies than to lower ones. As a result, a high-pitched sound will be heard more easily than a low-pitched sound of the same volume. Measuring devices compensate for this fact by using different weighing networks: dB(A), dB(B), and dB(C). Low frequencies are discriminated against most severely by the dB(A) network and least severely by the dB(C) network. Most measuring devices use dB(A). The dB(A) network is used because it most nearly records what the human ear hears. See Venema, *Surface Transportation Noise*, in *TRANSPORTATION NOISES: A SYMPOSIUM ON ACCEPTABILITY CRITERIA* 15, 21 (J. Chalupnik ed. 1970) [hereinafter cited as *TRANSPORTATION NOISE SYMPOSIUM*]. The dB(A) network is also used because such measuring devices "are easy to operate, portable and comparatively inexpensive." York, *Controlling Urban Noise Through Zoning Performance Standards*, 4 *URB. LAW.* 689, 695 (1972) (footnote omitted). Enthusiasm for dB(A) is not unanimous. "There is [a] considerable body of data showing that in the 1000-2000 Hz range where both medium and large [truck] . . . noise levels peak, the . . . C network [rather than the A network] more accurately measures the noise [level] in comparison with the ear." *Noise Control Extension Act, Hearings on H.R. 5272 Before the Subcomm. on Transportation and Commerce of the House Comm. on Interstate and Foreign Commerce, 94th Cong., 1st Sess.* 87 (1975) (statement of Lloyd Hinton, National Organization to Insure a Sound-controlled Environment (NOISE)). NOISE, however, was prepared to accept the dB(A) network on the basis of the need for uniformity. *Id.*

19. The information contained in Table I-3 has been derived from a variety of sources. See, e.g., U.S. DEP'T OF TRANSPORTATION, *TRANSPORTATION NOISE AND ITS CONTROL* 3 (1972) [hereinafter cited as *DOT REPORT*].



TABLE I-3

Source	dB(A)	Reaction
Rocket engine (nearby)	180	
Jet takeoff (nearby)	150	
Jet takeoff (200 ft./61 m.), discotheque	120	Threshold of pain
Riveting on a steel plate (6 ft./1.8 m.)	118	
Unsilenced motorcycle (2ft./6 m.)	108	
Jet takeoff (2000 ft./609.6 m.)	105	
New York City subway station	95	Very annoying
Heavy truck (50 ft./15.2 m.)	90	
Garbage truck (200 ft./61 m.), city bus (inside), busy street	85	
Traffic at a residential intersection	80	Annoying
Freeway traffic (50 ft./15.2 m.)	70	Intrusive
Light traffic (50 ft./15.2 m.)	55	
Business office	50	Quiet
Soft whisper (15 ft./4.6 m.)	30	Very quiet
Rustling leaves	10	Barely audible
	0	Threshold of hearing

At some point on the sound spectrum sound becomes noise. There is, however, no agreement as to where on the sound spectrum that point lies.

While there may be disagreement about when sound becomes noise, public opinion surveys indicate that a substantial majority of the public find their environment disturbingly noisy. A 1970 American survey found that 72% of the respondents classified their neighborhoods as noisy.<sup>20</sup> Those individuals who found their neighborhoods noisy were asked to indicate the source of that noise. Table I-4<sup>21</sup> summarizes their responses.

20. NATIONAL RESEARCH COUNCIL ANALYTICAL STUDIES FOR THE USEPA, NOISE ABATEMENT: POLICY ALTERNATIVES FOR TRANSPORTATION 62 (1977) [hereinafter cited as NRC TRANSPORTATION STUDY].

21. *Id.*

TABLE I-4

Source	Percentage
Motor vehicles	55
Aircraft	15
Voices	12
Radio and TV sets	2
Home maintenance equipment	2
Construction	1
Industrial	1
Other noises	6
Not ascertained	8

Three successive German surveys in the 1960's found 29%, 41%, and 54% of the respondents disturbed by noise.<sup>22</sup> Respondents in two of the surveys were asked to indicate the source of the disturbance. Their responses are summarized in Table I-5.<sup>23</sup>

TABLE I-5

Source	Emnid Institute Survey (1962) Percentage	Institute für Demoskopie Survey (1965) Percentage
Transportation Noise		69
Motor Vehicles	62	
Aircraft	17	
Industrial Noise	14	8
Neighborhood Noise	14	21
Other		2

Identical sounds do not always trigger the same reaction in the same person. Two people may react quite differently to the

22. 4 E. GOSSRAU, H. STEPHANY, W. CONRAD & W. DÜRRE, HANDBUCH DES LÄRM-SCHUTZES UND DER LUFTREINHALTUNG (Handbook of Noise Control and Clean Air Maintenance) ¶ 66,310 at 2 (1969-1979). One survey was conducted by the Emnid Institute in 1962; the second survey was conducted by the Allensbach Institute für Demoskopie in 1965; the third survey was conducted by the Wickert Institute in 1968.

23. *Id.*

same sound. A number of factors influence an individual's reactions: feelings about the necessity of the noise or the possibility of reducing it, feelings about the noise source and the value of its function, types of activities affected, other disamenities in the environment, feelings about the effect of noise on general health, general noise sensitivity, and the extent to which fear is associated with noise.<sup>24</sup> Another factor which deserves but has not received sufficient attention is the cultural factor. For example, an American motorist overtaking a slower moving motor vehicle in his lane of traffic expresses his impatience by honking his horn while a German motorist reacts to the same set of circumstances by blinking his lights. This simple situation is perhaps indicative of the rather high noise tolerance of Americans vis-à-vis Germans.

Since a number of factors influence individual reactions to noise, such reactions can be considered fluid rather than static. They can be and are molded.<sup>25</sup> If, for example, feelings about the value of a particular noise source decline, a concomitant rise in the negative reaction to the noise produced by that noise source is likely.

Noise, then, is usually defined simply as "unwanted sound"<sup>26</sup> or sound that is "unpleasant" or "annoying."<sup>27</sup> Unwanted, unpleasant, or annoying sound cannot be visually determined, does not collect in one place, is quickly dispersed, and leaves no visible record of its presence.<sup>28</sup> People, moreover, to some extent are able to adapt to noise. Perhaps because of these characteristics, ambient noise levels<sup>29</sup> increased for some time before causing con-

24. See Borsky, *Effects of Noise on Community Behavior*, in AMERICAN SPEECH AND HEARING ASSOCIATION, *NOISE AS A PUBLIC HEALTH HAZARD* 187, 189-91 (1969) [hereinafter cited as ASHA REPORT]. See generally S. SØRENSEN, *ON THE POSSIBILITIES OF CHANGING THE ANNOYANCE REACTION TO NOISE BY CHANGING THE ATTITUDES TO THE SOURCE OF THE ANNOYANCE* (1970).

25. For an interesting discussion of how reactions can be and are molded, see S. SØRENSEN, *supra* note 24.

26. SENATE DOCUMENT 63, *supra* note 15, at xxi. Noise can also be defined as an "environmental pollutant." *Id.* If this definition is adopted, "noise is any sound . . . that may produce an undesired physiological or psychological effect in an individual and that may interfere with the social ends of an individual or group." *Id.*

27. DER RAT VON SACHVERSTÄNDIGEN FÜR UMWELTFRAGEN, *UMWELTGUTACHTEN* 1974 (Environmental Assessments 1974), at 188 (1974) [hereinafter cited as ENVIRONMENTAL REPORT].

28. Noise differs from other environmental concerns in these respects. Its properties make it much more of a local problem. Local problems, however, are not necessarily minor problems. One study has described noise as an insidious threat. "[Its] insidiousness . . . lies exactly in this—in this ubiquity and in our unconcern and lack of awareness." NOISE POLLUTION IMPACT, *supra* note 13, at 4.

29. The ambient noise level is "that level which exists at any instant, regardless of

cern. These increases have led some to conclude that the ambient noise level is increasing at a rate of one decibel per year.<sup>30</sup> The available data,<sup>31</sup> however, suggest that ambient noise levels are increasing unevenly: the increase in established urban areas is gradual;<sup>32</sup> the increase in areas which have become or are becom-

source." SENATE DOCUMENT 63, *supra* note 15, at G-2. The United States Environmental Protection Agency prefers "environmental noise level" to "ambient noise level." These two terms can be used interchangeably. Ambient noise level, the more frequently used term, will be used in this comparative study.

Apparently, the ambient noise level became so serious a problem in ancient Greece that Hippocrates, the father of medicine, recommended that patients be kept as far as possible from sources of noise during convalescence. H. WIETHAUP, *LÄRMBEKÄMPFUNG IN DER BUNDESREPUBLIK DEUTSCHLAND* (Noise Control in the Federal Republic of Germany) 34 (2d ed. 1967). In China a law enacted in 211 B.C. provided for capital punishment by the use of noise: "He who slanders the nobility shall not be hanged, but the flute players, drummers, and noise makers shall play before him without pause until he dies because this type of death is the worst possible death that a human being can suffer." *Id.* at 33.

Ambient noise levels in the United States vary from a high of 77 dB(A) outside a third floor apartment next to a freeway to 16 dB(A) on the North Rim of the Grand Canyon. U.S. ENVIRONMENTAL PROTECTION AGENCY, *COMMUNITY NOISE 17-19* (1971) [hereinafter cited as *COMMUNITY NOISE REPORT*].

The table describes typical ambient noise levels in five different environments.

Environment	Typical Range (in dB(A))	Average (in dB(A))
Quiet suburban residential	36-40	38
Normal suburban residential	41-45	43
Urban residential	46-50	48
Noisy urban residential	51-55	53
Very noisy urban residential	56-60	58

This table is derived from information found in SENATE DOCUMENT 63, *supra* note 15, at 2-16.

30. See, e.g., 3 U.S. ENVIRONMENTAL PROTECTION AGENCY, *PUBLIC HEARINGS ON NOISE ABATEMENT AND CONTROL 107* (1971) (Urban Planning, Architectural Design, and Noise in the Home) (statement of Charles D. Parrott, Redevelopment Authority, La Crosse, Wis.) [hereinafter cited as *PUBLIC HEARINGS III*]; Hildebrand, *Noise Pollution: An Introduction to the Problem and an Outline for Future Legal Research*, 70 COLUM. L. REV. 652, 652-53 (1970); York, *supra* note 18, at 689-90.

31. The available data consists of five surveys conducted in residential areas in the United States between 1937 and 1971. An analysis of these surveys is found in *COMMUNITY NOISE REPORT*, *supra* note 29, at 82-88.

32. There was a 2 dB increase in the ambient noise level in urban areas between 1947-1948 and 1971. *Id.* at 86. The sharp conflict in views about the behavior of ambient noise levels is illustrated by two views of the situation in New York City. One view is expressed by Representative Ryan: "Ambient noise levels in midtown Manhattan already are in excess of 80 decibels. Urban noise has doubled since 1955 and is expected to double again by 1980." 118 CONG. REC. 6044 (1972). The other view emerges from an analysis of the results of surveys conducted by the New York Journal American, summarized in the table.

ing urbanized is more dramatic.<sup>33</sup>

Changing land-use patterns, therefore, are factors contributing to the increase in the ambient noise level. Noise is a more serious problem in urban than in rural areas. As a result, the more urbanized a society becomes, the more serious the noise problem.<sup>34</sup>

Another and interrelated factor is the growth in technology. Noise is frequently a product of machines. The more machines used, the more serious the noise problem. The problem is made

Location	1952 (in dB)	1959 (in dB)
Times Square	81	76
Union Station	72	64
Seventh Avenue at 38th Street	80	74
City Hall	70	64
Park Avenue at 49th Street	77	69

Soroka, *Community Noise Surveys*, in ASHA REPORT, *supra* note 24, at 175, 176-77. These results indicate not only that ambient noise levels "were 5 to 11 dB lower in 1959 than in 1952", but also that "some progress had been made in controlling noise in New York City." *Id.*

33. If land use changed from quiet suburban residential to very noisy residential, an increase in the ambient noise level of 20 dB(A) could be anticipated. See table in note 29 *supra*.

34. More and more areas are becoming urbanized.

Between 1959 and 1965 the number of metropolitan areas in the world with populations of 100,000 or more increased by 40 percent, from an estimated 1046 to an estimated 1409, and between 1951 and 1964 the percentage of world population in metropolitan areas of 1 million or more increased from 8.2 percent to 11.3 percent. . . .

Between 1960 and 2000, the fraction of the population in urban areas of 100,000 or more is expected to increase from 60 percent to 77 percent in North America, and from 29 percent to 48 percent in Europe. The greatest growth is expected to occur in the larger areas, rather than in the smaller ones of 100,000-300,000 inhabitants. . . .

In urban zones, the area is increasing twice as quickly as the population. . . .

In the United States, where . . . the urban fraction in areas over 100,000 in population is expected to reach 77 percent of the total population in 1985 and probably 90 percent by the year 2000, it is believed that urban concentration will take place primarily in 40 metropolitan areas each containing from 1 to 20 million inhabitants. By the year 2000 nearly one-half of the population of the United States will be living in 2 percent of the country's area, in spite of a decline in densities at town centers.

NOISE POLLUTION IMPACT, *supra* note 13, at 95-96.

even more serious because the public tends to equate noise with power and efficiency.<sup>35</sup> Such thinking discourages manufacturers from producing quieter machines because they fear public disapproval.<sup>36</sup>

## B. Why Study Traffic Noise?

### 1. Ever-increasing vehicle traffic

Machines that transport people and goods have definitely contributed to the increase in ambient noise levels.<sup>37</sup> Aircraft noise has received considerable attention.<sup>38</sup> In contrast, motor vehicle noise,<sup>39</sup> which disturbs twice as many people<sup>40</sup> and "is the predominant source of urban noise and constitutes its most pervasive element,"<sup>41</sup> has received far less attention.

Table I-6<sup>42</sup> shows by selected years the number of motor vehicles registered for operation in the United States.

---

35. One researcher discovered that the confidence of truck drivers in their trucks was directly proportional to the truck's noise output. Some truck drivers punched holes in newly installed mufflers in order to recapture a lost sense of power. Mathis, *Urban Noise: An Insidious but Escalating Pollutant*, 46 L.A.B.A. BULL. 438, 461 n.101 (1971). Young people, in particular, are subject to a "motorcycle syndrome." For a discussion of this syndrome, see Nicholi, *The Motorcycle Syndrome*, 126 AM. HUMAN PSYCH. 1588 (1970).

36. Manufacturers who have developed "quiet" products have encountered difficulty in marketing their products because consumers complain that the products are "underpowered." See, e.g., PUBLIC HEARINGS III, *supra* note 30, at 77 (statement of Robert H. Pish, Southwest Research Institute); N.Y. Times, Apr. 30, 1969, at 31, col. 4. This situation may be improving.

37. "The various modes of transportation, taken collectively, represent the major cause of complaints about noise." U.S. DEP'T OF COMMERCE, *THE NOISE AROUND US* 3 (1970). See also DOT REPORT, *supra* note 19, at 1.

38. See, e.g., Spater, *Noise and the Law*, 63 MICH. L. REV. 1373 (1965).

39. Motor vehicle noise is noise produced by the operation of an automobile, truck, bus, or motorcycle.

40. Seybert, *Studies of Combustion and Mechanically Induced Noise in Diesel Engines*, in PROCEEDINGS OF THE EPA—UNIVERSITY NOISE SEMINAR 159 (1976).

41. ORGANISATION FOR ECONOMIC CO-OPERATION AND DEVELOPMENT, *URBAN TRAFFIC NOISE: STRATEGY FOR AN IMPROVED ENVIRONMENT* 13 (1971) [hereinafter cited as OECD REPORT]. The dominance of motor vehicle noise can be explained by a variety of factors, including "the permissible noise level for motor vehicles, the increasing use of motor vehicles, the resultant increase in the density of traffic in residential areas, and insufficient consideration given to motor vehicle noise in city planning." ENVIRONMENTAL REPORT, *supra* note 27, at 206.

Hans Wiethaup, one of the leading legal authorities on noise in the Federal Republic of Germany, has described motor vehicle noise as "the greatest obstacle in the complex of problems associated with noise regulation." H. WIETHAUP, *supra* note 29, at 12.

42. Table I-6 is based on information collected by the Federal Highway Administration and supplied to the author.

TABLE I-6

Year	Automobiles (thousands)	Buses (thousands)	Trucks (thousands)	Motorcycles (thousands)	All Motor Vehicles (thousands)
1955	52,145	255	10,289	412	63,101
1960	61,682	272	11,914	563	74,431
1965	75,241	314	14,786	1,882	91,723
1970	89,231	378	18,767	2,824	111,200
1971	92,742	397	19,848	3,344	116,331
1972	97,096	404	21,279	3,760	122,542
1973	101,985	425	23,260	4,371	130,041
1974	104,857	447	24,589	4,966	134,859
1975	106,719	462	25,781	4,964	137,926
1976	110,351	478	27,720	4,985	143,538
1977	113,667	493	29,584	5,015	148,759
1978	116,575	500	31,703	5,142	153,920

During the years 1971 to 1978, the annual percentage increase in the total number of motor vehicles registered for operation in the United States has fluctuated from a high of 5.8% to a low of 2.2%, as shown by Table I-7.<sup>43</sup>

The Federal Highway Administration also collects information on state motor vehicle registrations. The following table shows motor vehicle registrations for New York State.

Year	Automobiles (thousands)	Buses (thousands)	Trucks (thousands)	Motorcycles (thousands)	All Motor Vehicles (thousands)
1955	4,132	18	493	21	4,664
1960	4,514	20	533	16	5,083
1965	5,309	26	603	45	5,983
1970	6,000	30	688	86	6,804
1971	6,163	30	698	78	6,969
1972	6,270	29	707	80	7,086
1973	6,532	30	758	90	7,410
1974	6,638	30	790	108	7,566
1975	6,735	31	825	113	7,704
1976	6,734	30	886	121	7,771
1977	6,799	30	901	132	7,862
1978	6,908	32	927	144	8,011

43. Table I-7 is derived from Table I-6.

TABLE I-7

Year	Annual Percentage Increase in Motor Vehicles
1971	4.4
1972	5.1
1973	5.8
1974	3.6
1975	2.2
1976	3.9
1977	3.5
1978	3.4

Table I-8<sup>44</sup> shows by selected years the number of motor vehicles registered for operation in the Federal Republic of Germany.

44. Table I-8 is based on information collected by the Kraftfahrt-Bundesamt (Federal Office of Motor Vehicles) of the Federal Republic of Germany and supplied to the author.

The Kraftfahrt-Bundesamt also collects information on state motor vehicle registrations. The following table shows motor vehicle registrations for Bavaria.

Year	Automobiles (thousands)	Buses (thousands)	Trucks (thousands)	Motorcycles (thousands)	All Motor Vehicles (thousands)
1955	308	4	87	589	988
1960	775	4	102	414	1,295
1965	1,609	5	141	152	1,907
1970	2,427	8	172	53	2,660
1971	2,647	8	181	47	2,883
1972	2,810	9	186	46	3,051
1973	2,985	9	193	48	3,235
1974	3,056	10	193	51	3,310
1975	3,134	10	191	54	3,388
1976	3,289	11	190	61	3,551
1977	3,494	11	195	70	3,770
1978	3,698	11	199	82	3,990



TABLE I-8

Year	Automobiles (thousands)	Buses (thousands)	Trucks (thousands)	Motorcycles (thousands)	All Motor Vehicles (thousands)
1955	1,748	27	603	2,495	4,873
1960	4,490	33	681	1,892	7,096
1965	9,267	39	876	717	10,899
1970	13,942	47	1,028	229	15,246
1971	15,115	50	1,078	201	16,444
1972	16,055	53	1,107	198	17,413
1973	17,023	56	1,138	213	18,430
1974	17,341	58	1,136	230	18,765
1975	17,899	60	1,122	250	19,331
1976	18,920	62	1,122	292	20,396
1977	20,020	64	1,146	343	21,573
1978	21,211	66	1,175	403	22,855

During the years 1971 to 1978, the annual percentage increase in the total number of motor vehicles registered for operation in the Federal Republic of Germany has fluctuated from a high of 7.1% to a low of 2.4%, as shown by Table I-9.<sup>45</sup>

TABLE I-9

Year	Annual Percentage Increase in Motor Vehicles
1971	7.3
1972	5.6
1973	5.5
1974	1.8
1975	2.9
1976	5.2
1977	5.4
1978	5.6

As the foregoing tables demonstrate, the total number of motor vehicles is increasing in both the United States and the Federal Republic of Germany. Much of the total travel by these motor vehicles is on urban streets.<sup>46</sup> The problem of urban traffic

45. Table I-9 is derived from Table I-7.

46. Approximately 52% of the total travel in the United States is on urban streets. Federal Highway Administration News 108-72, at 1 (1972). More than 20% of the urban population in the Federal Republic of Germany live along highways with "a high noise level." SCHRIFTENREIHE DES BUNDESMINISTERIUMS DES INNERN, UMWELTPLANUNG: MATERIALIEN ZUM UMWELTPROGRAMM DER BUNDESREGIERUNG (Environmental Planning: Materials

noise, then, is becoming more serious.<sup>47</sup> Something must be done to regulate this ever-increasing amount of traffic noise or the problem will become unmanageable.

Before determining the best method or methods to regulate traffic noise, however, one needs to understand the factors affecting traffic noise. Some of the important factors affecting traffic noise emissions should therefore be described.

## 2. Factors affecting traffic noise emissions

a. *Speed of motor vehicle.* Direct relationships exist between the speed at which a motor vehicle is traveling and the level and type of noise produced.<sup>48</sup> At a constant traffic density,<sup>49</sup> doubling the average speed increases the average noise level by 6 dB(A).<sup>50</sup> Propulsion system noise dominates at lower speeds;<sup>51</sup> tire

---

for the Environmental Program of the Federal Government) 251 (1971) [hereinafter cited as ENVIRONMENTAL PLANNING].

One estimate places the ambient noise level along heavily traveled highways in the Federal Republic of Germany at 85 dB(A). *Id.* at 249. Another estimate indicates that ambient noise levels in residential areas in the Federal Republic of Germany vary from a low of 60 dB(A) to a high of 75 dB(A). ENVIRONMENTAL REPORT, *supra* note 27, at 207.

47. The number of motor vehicles should continue to increase. For example, German officials projected an increase of 43.2% in the number of motor vehicles between 1971 and 1985. ENVIRONMENTAL PLANNING, *supra* note 46, at 251. A 43.2% increase in the number of motor vehicles does not mean, however, a 43.2% increase in the noise level because the decibel scale is logarithmic. See note 15 *supra*. If the German projection proves to be accurate and the highway system remains unchanged, the ambient noise level will increase by 3 dB(A) as a result of a 43.2% increase in the number of motor vehicles. Three dB(A) represents a 30% increase.

The National Research Council study takes an even more optimistic view of what increases in the number of motor vehicles will mean in terms of increases in the noise level: "Thus, if all transportation activities were doubled with existing vehicles and facilities only a 3-dB increase in general environmental noise levels would result. . . . Since new vehicles . . . are quieter than those they replace, it is likely that overall transportation noise will remain relatively constant even with increased operations." NRC TRANSPORTATION STUDY, *supra* note 20, at 4.

48. "The quietest group of vehicles is automobiles travelling at speeds less than 35 mph, and the noisiest group is trucks at speeds in excess of 35 mph. In the middle are low speed trucks, high speed autos, and motorcycles at all speeds." W. CLOSE, REGULATORY IMPLICATIONS OF TRUCK TIRE NOISE STUDIES 1 (Society of Automotive Engineers (SAE) Paper No. 740606 1974).

49. Traffic density is the number of vehicles which pass by a given point in a given period of time.

50. U.S. ENVIRONMENTAL PROTECTION AGENCY, TRANSPORTATION NOISE AND NOISE FROM EQUIPMENT POWERED BY INTERNAL COMBUSTION ENGINES 112 (1971) [hereinafter cited as TRANSPORTATION NOISE STUDY]. A 6 dB(A) increase may be conservative. According to a study conducted by the National Physical Laboratory in Great Britain, the average noise level increases by 9 dB(A) when the average speed is doubled. OECD REPORT, *supra* note 41, at 35.

51. Exhaust noise and induction noise are two components of propulsion system

noise becomes dominant at higher speeds.<sup>52</sup>

b. *Type of motor vehicle.*<sup>53</sup> Automobiles, while less noisy than trucks, buses, and motorcycles, are a significant contributor to urban noise due to their numbers.<sup>54</sup> Trucks are possibly the single largest contributor to urban noise.<sup>55</sup> In 1971 approximately 97.5% of the trucks driven in America were powered by gasoline engines. The remaining 2.5% were powered by noisier diesel engines.<sup>56</sup> While exhaust noise,<sup>57</sup> cooling fan noise,<sup>58</sup> intake noise,<sup>59</sup>

---

noise. Exhaust noise exceeds induction noise by 10-15 dB throughout the audible range. TRANSPORTATION NOISE STUDY, *supra* note 50, at 97.

52. The Department of Transportation concludes that "much if not most noise produced by vehicles [on today's high speed highways] can be attributed to the tires." DOT REPORT, *supra* note 19, at 10. Tire noise depends on tread design, state of wear, axle load, and road surface. TRANSPORTATION NOISE STUDY, *supra* note 50, at 97. The interaction of these four factors can produce a 20 dB range in noise levels at a constant speed. *Id.* For a discussion of tire noise, see 2 U.S. ENVIRONMENTAL PROTECTION AGENCY, PUBLIC HEARINGS ON NOISE ABATEMENT AND CONTROL 150-58 (1971) [hereinafter cited as PUBLIC HEARINGS II].

53. There are a number of studies that have analyzed traffic noise by the type of motor vehicle. See, e.g., NOISE POLLUTION IMPACT, *supra* note 13, at 83-86, 101-04; PUBLIC HEARINGS II, *supra* note 52, at 106-24 (statement of Ernest S. Starkman, General Motors); GRAD & ROSENTHAL, *supra* note 14, at 441-44; NRC TRANSPORTATION STUDY, *supra* note 20, at 165-76.

54. TRANSPORTATION NOISE STUDY, *supra* note 50, at 107-08. In 1976 automobiles represented 110,351,000 or 77% of the 143,538,000 motor vehicles registered for operation in the United States, and 18,920,000 or 85% of the 22,292,000 motor vehicles registered for operation in the Federal Republic of Germany.

The Department of Transportation estimates that "the percentage of automobile noise sources above 75 dB(A) is 37%." DOT REPORT, *supra* note 19, at 10.

55. See PUBLIC HEARINGS II, *supra* note 52, at 118 (statement of Ernest S. Starkman, General Motors). In Ottawa, Canada, for instance, trucks represent about five percent of all motor vehicles and contribute more noise than all the rest put together. Thiessen, *Community Noise Levels*, in TRANSPORTATION NOISE SYMPOSIUM, *supra* note 18, at 23, 31. One study found that the median sound level for a highway with 100 automobiles per mile is equal to a highway with 16 automobiles and 4 trucks per mile. Thus, "four trucks at 50 mph are equivalent . . . to 84 autos." DOT REPORT, *supra* note 19, at 11. Another study found that the noise from a heavy truck is equivalent to the noise from 10 to 15 automobiles. NOISE POLLUTION IMPACT, *supra* note 13, at 83. According to the Environmental Protection Agency, medium and heavy-duty trucks produce a typical sound level of 84 dB(A) at 50 ft./15.2 m. and an estimated total sound energy of 5800 kWh/day. 39 Fed. Reg. 22,297-98 (1974). Heavy trucks do not contribute uniformly to total traffic noise. The available data suggest that their contribution is greater on city streets than it is on freeways. See NOISE POLLUTION IMPACT, *supra* note 13, at 136-38.

56. TRANSPORTATION NOISE STUDY, *supra* note 50, at 100. Diesel-powered trucks are "8 to 10 dB noisier than gasoline powered trucks and 12 to 18 dB noisier than automobiles." *Id.*

57. Exhaust noise depends on the type of engine, engine back pressure, timing, and the type, size, and location of the muffler. *Id.*

58. Cooling fan noise "increases at a rate of 2 dB per 100 rpm at speeds between 1000 and 1500 rpm and at a rate of 1 dB per 100 rpm [at speeds] between 1500 and 2000 rpm." *Id.* at 103. Cooling fan noise also depends on "tip speed and configuration, blade design and spacing, and proximity of accessories and other objects which affect air flow." *Id.*

59. Intake noise increases in direct proportion to the load being carried by a truck.

and engine noise all contribute to total truck noise, particularly at speeds up to 50 mph/80 kmph, at speeds in excess of 50 mph/80 kmph, tire noise is "the major obstacle in limiting overall vehicle noise."<sup>60</sup> The type of tire tread<sup>61</sup> influences the noise level: "low noise" tread design tires produce levels of 75 dB(A); "high noise" tread design tires produce levels in excess of 90 dB(A).<sup>62</sup> Tire wear,<sup>63</sup> recapping,<sup>64</sup> and axle load<sup>65</sup> also influence truck noise levels. Buses and trucks share design characteristics and components. Buses, however, are less noisy than trucks because their engine compartment is enclosed and their mufflers are larger.<sup>66</sup> In contrast to the other types of motor vehicles, motorcycle tire noise is a rather insignificant contributor to total motorcycle noise.<sup>67</sup>

---

The increase between no-load and full-load ranges from 20-25 dB for gasoline powered trucks and from 10-15 dB for diesel powered trucks. *Id.*

60. *Id.* at 105.

61. There are approximately 1000 different truck tire treads offered for sale. W. CLOSE, *supra* note 48, at 2.

62. TRANSPORTATION NOISE STUDY, *supra* note 50, at 105. Crossbar tires, used by the vast majority of trucks in the United States, are a "high noise" tread design. They have "aggressive lug features somewhat like snow tires." W. CLOSE, *supra* note 48, at 2. Crossbar tires produce noise levels of 80-85 dB(A) when new, increasing by as much as 10 dB(A) when the tires are half-worn or recapped. TRANSPORTATION NOISE STUDY, *supra* note 50, at 105. Rib tires are a "low noise" tread design. They look like automobile tires. W. CLOSE, *supra* note 48, at 2.

If rib tires are quieter, why does the trucking industry prefer crossbar tires? "[C]rossbar tires typically offer about two and a half times the mileage of continuous rib tires on drive axle." PUBLIC HEARINGS II, *supra* note 52, at 152 (statement of Seymour Lippman, Uniroyal).

63. As tires wear, the noise level increases. Since the wear cycle of a truck tire may be 125,000 miles, truck tire noise data are difficult to obtain. The only reliable method to obtain such data is to put a tire on a truck in an active truck fleet and test it throughout the wear cycle. This method involves numerous tests and a long waiting period. Based on available data, "the maximum noise occurs at about the half-worn point and, if one were to give a realistic appraisal, one would say that most tires are half-worn." W. CLOSE, *supra* note 48, at 2.

64. A recapped tire is called a "Singing Sam" because of the loud, tonal sound it produces. *Id.* Crossbar tires are recapped an average of two or three times. TRANSPORTATION NOISE STUDY, *supra* note 50, at 105.

65. For example, a 15 dB decrease resulted when the load per tire on retread tires was reduced from 4500 pounds to 1240 pounds. TRANSPORTATION NOISE STUDY, *supra* note 50, at 107.

66. *Id.* at 110. In spite of the fact that buses are less noisy than trucks, they can produce annoying noise. A person standing at the curb when a city bus pulls away, for example, is subjected to an ever-increasing noise level which may exceed 90 dB(A) before the engine intake grille passes. *Id.* at 110, 112. See also GRAD & ROSENTHAL, *supra* note 14, at 452 n.28.

67. According to estimates by manufacturers and a research organization, tire noise at moderate speeds of 30-40 mph/48-64 kmph is 60 dB(A) at 50 ft./15.2 m. for a 1973 motorcycle with a displacement greater than 200 cc. 1 U.S. ENVIRONMENTAL PROTECTION AGENCY, CONTROL OF MOTORCYCLE NOISE, TECHNOLOGY AND COST INFORMATION 20-21 (1974).

Motorcycle exhaust noise, intake noise, and engine noise are the major contributors.<sup>68</sup>

*c. Age of motor vehicle.* Motor vehicles become noisier as they age. For example, automobiles more than two years old tend to produce noise levels two to three decibels higher than new models.<sup>69</sup> Seventy percent of the automobiles operated in the United States in 1970 were three or more years old.<sup>70</sup> Sixty percent of the trucks operated in the United States in that same year were more than five years old.<sup>71</sup>

*d. Weather conditions.* Wind, temperature, snow,<sup>72</sup> and rain<sup>73</sup> also have a minor effect on the noise level produced by motor vehicles.

*e. Time of day.* One would expect the ambient noise level to drop at night. Surprisingly, surveys have shown that the noise reduction during an average "noise night" (the period of reduced noise levels) is moderate and of short duration.<sup>74</sup>

*f. Traffic flow.* Acceleration and deceleration are noisier phases of motor vehicle operation than cruising.<sup>75</sup> Stop-and-go

68. Total motorcycle noise for a 1973 motorcycle with a displacement greater than 200 cc. is estimated to be about 84.5 dB(A). *Id.*

69. TRANSPORTATION NOISE STUDY, *supra* note 50, at 108. These results are confirmed by other studies. A German study comparing motor vehicles manufactured from 1961-1963 with motor vehicles manufactured from 1958-1960, found that the older vehicles reached levels of 79 dB(A) during 50% of driving time while the newer vehicles reached levels of 77 dB(A) during 50% of driving time. OECD REPORT, *supra* note 41, at 53. An American study entitled "Objective Limits of Motor Vehicles Noise" determined that the average difference between new vehicles (1962) and older vehicles was 5 dB(A); in some cases, the difference exceeded 10 dB(A). *Id.*

70. TRANSPORTATION NOISE STUDY, *supra* note 50, at 108. The average age of the automobiles operated in the United States in 1970 was five and one-half years. *Id.*

71. *Id.* at 100.

72. Snow itself may reduce the noise level. For example, a blanket of snow on the ground can result in a noise reduction of 2-3 dB in the middle octave band levels. OECD REPORT, *supra* note 41, at 34. However, the reduction in noise level resulting from snow on the ground may be offset by an increase in the high frequency noise level if motor vehicles equipped with studded winter tires are extensively used, particularly on dry streets. *Id.*

73. Rain may increase the noise produced by a single motor vehicle, but it also tends to lower the speed at which motor vehicles travel. Consequently, the noise level does not change significantly. See NOISE POLLUTION IMPACT, *supra* note 13, at 140.

74. A Canadian researcher found a 10-12 dB(A) difference between daytime and nighttime noises in the cities he studied. Nighttime, however, is only three or four hours long. Beranek, *Summary*, in TRANSPORTATION NOISE SYMPOSIUM, *supra* note 18, at 34. A survey conducted in London found that the "noise night" began in only 25% of the measuring locations before midnight and ended in only 11% of the same locations after 6:30 a.m. OECD REPORT, *supra* note 41, at 34.

75. According to a study conducted by the Federal Republic of Germany's Bundesanstalt für Strassenwesen (Federal Institute for Roads and Highways), the noise level rises

traffic creates high "noise peaks"<sup>76</sup> but a lower average ambient noise level than when traffic is flowing smoothly.<sup>77</sup> One-way streets assist the flow of traffic but require another street to permit traffic to flow in the opposite direction.<sup>78</sup>

*g. Traffic density.* At a constant average speed, doubling the number of motor vehicles per hour increases the average noise level by 3 dB(A).<sup>79</sup> Noise continues to increase until traffic density reaches 2500 motor vehicles per hour where it stabilizes at about 85 dB(A) with noise peaks up to 93 dB(A).<sup>80</sup> Traffic density and the occurrence of noise peaks are directly related: doubling the number of motor vehicles doubles the frequency at which noise peaks occur.<sup>81</sup>

*h. Natural and manmade environment.* Some motor vehicle noise is absorbed by the natural environment. For example, noise can be influenced to some degree by distance and by vegeta-

---

by as much as 18 dB(A) when a light changes from red to green. OECD REPORT, *supra* note 41, at 55. See also NOISE POLLUTION IMPACT, *supra* note 13, at 83.

76. As a motor vehicle approaches an individual or a measuring point, the noise level increases, reaches a maximum level called a "peak," and then decreases as the motor vehicle recedes. A steady flow of traffic produces a more-or-less steady "background" noise. However, sports cars, motorcycles, and trucks reach higher peaks than other motor vehicles and are responsible for "noise peaks" which stand out against the background noise. OECD REPORT, *supra* note 41, at 29, 32.

77. *Id.* at 35. Smooth, slow traffic produces a low average noise level and relatively low noise peaks. In contrast, smooth, rapid traffic produces the highest average noise level. *Id.* In a study entitled "Noise in Urban and Suburban Areas: Results of Field Studies," a 10-minute sample of stop-and-go traffic in New York City was taken. This sample showed a mean value of 81 dB(A) at 15 ft. from the traffic. *Id.* at 54.

78. Since another high-density street may not be available adjacent to the street being converted to a one-way street, "a reasonably quiet, residential road or even a side street [may become] a major traffic artery." C. DUERDEN, NOISE ABATEMENT 91 (1971).

79. OECD REPORT, *supra* note 41, at 35. The table illustrates the relationship between density, expressed in motor vehicles per 24 hour period, and ambient noise levels, expressed in dB(A).

Density (vehicles/24 hr. period)	Ambient Noise Level (in dB (A))	
	Day	Night
under 10,000	67	64
10,000 - 40,000	69	66
over 40,000	73	72

ENVIRONMENTAL PLANNING, *supra* note 46, at 249.

80. C. DUERDEN, *supra* note 78, at 92-93.

81. OECD REPORT, *supra* note 41, at 35.

tion or terrain.<sup>82</sup> Man can also alter his environment to reduce both the amount of noise and the effect of that noise. Gentle grades<sup>83</sup> and smooth road surfaces<sup>84</sup> reduce the amount of noise; noise screens,<sup>85</sup> depressed highways,<sup>86</sup> tunnels,<sup>87</sup> sound-proofing,<sup>88</sup>

---

82. Distance effectively reduces noise. If the traffic density and average speed are constant, the average noise level decreases by 3 dB(A) with each doubling of the distance from the centerline of the highway. TRANSPORTATION NOISE STUDY, *supra* note 50, at 112. Noise from individual motor vehicles, however, decreases by 6 dB(A) rather than 3 dB(A) with each doubling. See NRC TRANSPORTATION STUDY, *supra* note 20, at 84.

Vegetation is less effective in reducing noise. Swiss and Scandinavian studies indicate that dense plantings of trees, 100 meters in depth, will only result in noise reductions of 5 dB. OECD REPORT, *supra* note 41, at 59. Vegetation does offer psychological benefits. See PUBLIC HEARINGS II, *supra* note 52, at 97 (statement of Harter M. Rupert, Federal Highway Administration). It is questionable whether these largely psychological benefits can be justified in terms of cost. "One estimate of the cost of planting a mixture of shrubs and trees is \$7,500 per 100 square feet or about \$49,000 for a typical city block . . . exclusive of the costs of the land." NRC TRANSPORTATION STUDY, *supra* note 20, at 180.

Rolling ground with scattered woods or buildings provides a shielding effect of 10-15 dB(A), depending on distance between the source and the observer. Thiessen, *Community Noise Levels*, in TRANSPORTATION NOISE SYMPOSIUM, *supra* note 18, at 23, 26. Buildings have a shielding effect of 10-20 dB(A). Unfortunately, buildings not only shield, they also reflect. See note 89 *infra*.

83. Long, steep grades can add 5 dB(A) to the noise level. FEDERAL HIGHWAY ADMINISTRATION, NOISE STANDARDS AND PROCEDURES 5 (1974) [hereinafter cited as FHWA NOISE STANDARDS].

84. Whether smooth road surfaces are quieter or noisier than rough road surfaces is debatable. The conventional view is that smooth road surfaces can be 5 dB(A) quieter than average road surfaces and 10 dB(A) quieter than rough road surfaces. *Id.* See also NOISE POLLUTION IMPACT, *supra* note 13, at 139 (stone paved surfaces are 6-8 dB(A) noisier than smooth surfaces). Even if the conventional view is accepted, surfaces other than a smooth surface may be chosen. Safety considerations, for example, frequently dictate an average or rough road surface because traction on those surfaces is greater. Another view is represented by a Uniroyal spokesman who maintains that "smooth road surfaces . . . create more noise than rough road surfaces." PUBLIC HEARINGS II, *supra* note 52, at 153 (statement of Seymour Lippman, Uniroyal).

85. For a discussion and evaluation of 16 different screening systems, see A. RUCKER & K. GLÜCK, BAULICHE SCHUTZMASSNAHMEN ZUR MINDERUNG DES STRASSENVERKEHRLÄRMS (Protective Structures for Reduction of Traffic Noise) (1966). Noise screens achieve approximately the same noise level reduction as depressed highways at much less cost. PUBLIC HEARINGS II, *supra* note 52, at 97 (statement of Harter M. Rupert, Federal Highway Administration). Noise screens vary in expense depending on the material used. An earth noise screen, reducing noise levels by 10 dB(A), costs between \$17,000 and \$29,000 per city block. A concrete noise screen, reducing noise levels by 12-15 dB(A), costs between \$36,000 and \$50,000 per city block. NRC TRANSPORTATION STUDY, *supra* note 20, at 180.

86. Depressed highways can reduce the noise level by at least one-half. PUBLIC HEARINGS II, *supra* note 52, at 97 (statement of Harter M. Rupert, Federal Highway Administration).

Tests by the California Division of Highways have shown that while a diesel truck produces an 80 dB(A) noise level 100 feet from an expressway on flat, open terrain, the noise level at the same distance is reduced to 69 dB(A) if the roadway is depressed 20 feet below the adjacent land. A further reduction to 65 dB(A) is achieved by construction of an 8-foot high noise shield along the right-of-way above the depressed roadway.

and the acquisition of wider rights-of-way<sup>89</sup> reduce the effect of noise.

### C. *How Can Traffic Noise Be Regulated?*

#### 1. *Regulation techniques*

Since the noise level produced by motor vehicles is influenced by so many factors, the problem posed by traffic noise is not susceptible to a simple solution. A variety of techniques, grouped in four categories, have been used to regulate traffic noise.

a. *Source modification.* There is general agreement that source modification is the technique that deserves highest priority.<sup>90</sup> This technique involves several steps. The first step is redesigning the intake, exhaust, cooling fan, engine, and tires of the motor vehicle.<sup>91</sup> Second, the aerodynamic design of the vehicle

---

#### D. ANTHROP, NOISE POLLUTION 75 (1973).

Depressed highways are expensive: "[I]f the cost of constructing an urban roadway at ground level is equal to 100, building it in a cut with sloping banks will vary between 130 and 200, and with vertical walls between 400 and 600." NOISE POLLUTION IMPACT, *supra* note 13, at 147. Due to the cost factor, it is unlikely that a highway would be depressed "solely to obtain a reduction in noise." PUBLIC HEARINGS II, *supra* note 52, at 97 (statement of Harter M. Rupert, Federal Highway Administration).

87. Tunnels are enormously expensive: "[B]uilding a road in a bored tunnel is 13 times more expensive than building it at ground level . . ." NOISE POLLUTION IMPACT, *supra* note 13, at 147.

88. Neither the United States nor the Federal Republic of Germany recognize a federal mandate for soundproofing. The reluctance to recognize such a mandate results in part from the costs associated with soundproofing. "The cost of soundproofing new dwellings . . . varies in the United States between 2 percent and 10 percent of the total cost of the dwelling . . ." *Id.* at 155.

89. Noise reflection is a serious problem, particularly in urban areas. "A narrow street lined with high buildings is a veritable 'noise canyon' where, if all other factors remain unchanged, the noise can be up to 6 dB(A) higher than in an open space." *Id.* at 139. Wider rights-of-way provide buffer zones on either side of the highway and thereby diminish noise reflection. PUBLIC HEARINGS II, *supra* note 52, at 96 (statement of Harter M. Rupert, Federal Highway Administration). For example, a 10 dB(A) reduction at the right-of-way line is possible if 200-300 ft. of additional right-of-way is acquired on either side of the highway. FHWA NOISE STANDARDS, *supra* note 83, at 6. Wider rights-of-way, however, are costly. The Environmental Protection Agency has estimated not only the costs of land acquisition, but also the relocation costs for families in areas affected by traffic noise. Costs of land acquisition were estimated to be \$2.68 billion (268,000 acres at \$10,000/acre). Relocation costs were estimated to be \$1.25 billion (500,000 families at \$2500/family). Both cost estimates are stated in 1970 prices. NOISE POLLUTION IMPACT, *supra* note 13, at 375.

90. *See, e.g.,* OECD REPORT, *supra* note 41, at 47.

91. Until recently, there was practically no incentive to reduce the noise produced by the motor vehicle itself because customers were not demanding quieter motor vehicles. No manufacturer, therefore, was prepared to develop and build a quieter motor vehicle for the simple reason that he would be at a competitive disadvantage unless customers



can be altered. Third, older, noisier motor vehicles can be eliminated.

*b. Operational modification.* Operational modifications include rerouting motor vehicles, particularly trucks, away from residential areas;<sup>92</sup> lowering speed limits to diminish ambient noise levels; synchronizing traffic lights and creating one-way streets to reduce stop-and-go traffic;<sup>93</sup> prohibiting the use of horns, bells, and sirens except in times of emergency;<sup>94</sup> and regulating commercial traffic.<sup>95</sup>

*c. Transmission path modification.* Modification of the transmission path of motor vehicle noise involves maintaining a minimum distance between highways and buildings used either for residential or occupational purposes,<sup>96</sup> widening

---

wanted quieter motor vehicles and were prepared to pay the added costs of quieting existing motor vehicles. This situation is changing, and manufacturers are responding to growing pressure, initially from government and subsequently from customers, for quieter motor vehicles. General Motors, for example, has developed a "quiet refuse truck" for the State of New York which is equipped with larger mufflers, a silenced air cleaner, additional engine seals, a "quiet" cooling fan, and "low noise" tread design tires. GM also isolated the hydraulic valves and lines, cushioned certain components, and dampened the body panels in the packing unit. As a result, the noise level during the packing cycle was reduced from 87 dB(A) to 80 dB(A) at 50 ft./15.2 m. The estimated cost was \$3000 per refuse truck. TRANSPORTATION NOISE STUDY, *supra* note 50, at 132.

Source modification, however, may involve negative tradeoffs. For example, the "obvious" solution to the problem of truck tire noise is to ban crossbar tires. See note 62 and accompanying text *supra*. Such a ban would reduce total truck noise, particularly at speeds in excess of 50 mph/80 kmph, by 12-15 dB(A). Unfortunately, this ban would also have serious repercussions with regard to operating cost and safety since crossbar tires exhibit superior wear and traction characteristics. TRANSPORTATION NOISE STUDY, *supra* note 50, at 128.

92. Motor vehicles can be rerouted around major urban areas by using "ring-roads." This device is a popular one because few cities have street patterns which permit quick and efficient traffic flow from one side of the city to the other side. Unfortunately, ring-roads have not been particularly successful in reducing the impact of motor vehicle noise. There are at least two reasons. First, no rerouting plan can be entirely successful because a ring-road cannot be constructed that will not have an effect on people as they live and work. Second, the capacity of the population to expand outward is greater than the capacity of highway planners to design and construct ring-roads. Thus, ring-roads planned for the outer reaches of an urban area are often located within the suburbs by the time the ring-roads are completed.

93. Synchronized traffic lights may involve negative tradeoffs. For example, synchronized traffic lights tend to raise the average speed of all traffic and thereby increase tire noise. One-way streets may also involve negative tradeoffs. See note 78 *supra*.

94. New York City had an ordinance prohibiting hornhonking. See Section IV, notes 5-9 and accompanying text *infra*.

95. Commercial traffic can be regulated by limiting the hours during the day when trucks can load and unload.

96. A Swiss study indicates that there are two zones near a highway. The "fore area" is the area near the highway where the ambient noise level is nearly constant. Its width varies from a few meters to 100 m., depending on the traffic density. Behind this fore area

streets,<sup>97</sup> using the natural and manmade environment,<sup>98</sup> and establishing specific zones with maximum permissible noise limits.<sup>99</sup>

*d. Architectural modification.* Architectural modifications include designing buildings so that those parts that are most vulnerable to noise—bedrooms, for example—are located as far as possible from highways.<sup>100</sup> Other modifications involve experimenting with the type and size of windows that are installed.<sup>101</sup>

---

is a "rear area." The ambient noise level at any point in the rear area is inversely proportional to its distance from the highway. OECD REPORT, *supra* note 41, at 56.

The relationship between noise peaks and distance is even more pronounced. At 200 m. from the highway, noise peaks are no longer a factor. *Id.*

97. Narrow streets are conducive to amplification and reverberation. For example, a 95 dB noise source is amplified to 100 dB if the street is 12 m. wide and to 105 dB if the street is 6 m. wide. *Id.* at 59.

98. Rucker and Glück studied 16 different screening systems. They concluded that noise reductions of up to 27 dB were possible. Impervious sound-absorbing elements produced the best results; overlapping sound-absorbing slats, similar to venetian blinds, also produced good results. See A. RUCKER & K. GLÜCK, *supra* note 85.

99. A number of countries have established specific zones with maximum permissible noise limits. The table summarizes the approach adopted by Switzerland.

Environment	Ambient Noise Level (in dB(A))		Frequent Peaks (in dB(A))		Infrequent Peaks (in dB(A))	
	Night	Day	Night	Day	Night	Day
Hospital and convalescent	35	45	45	50	55	55
Quiet Residential	45	55	55	65	65	70
Mixed	45	60	55	70	65	75
Commercial	50	60	60	70	65	75
Industrial	55	65	60	75	70	80
Main arterial road	65	70	70	80	80	90

OECD REPORT, *supra* note 41, at 61.

100. *Id.* at 62. For a discussion of the effect architectural modifications can have, see A. RUCKER & K. GLÜCK, DIE AUSBREITUNG UND DÄMPFUNG DES STRASSENVERKEHRLÄRMS IN BEBAUUNGSGEBIETEN: STRASSENBAU UND STRASSENVERKEHRSTECHNIK (The Dissipation and Suppression of Traffic Noise in Construction Zones: Road Construction and Traffic Technology) (1964).

101. The Building Research Station in the United Kingdom and the Federal Materials Testing Laboratory in Switzerland have investigated the difference between outdoor and indoor noise levels under various conditions. The results of these investigations are summarized in this table.

## 2. *Modification options*

In implementing one or more of the techniques within the four categories of modifications, various options<sup>102</sup> ranging from direct regulation to self-government are available.

*a. Direct regulation.* Direct regulation usually includes technical specifications or noise emission standards for some or all motor vehicles. Direct regulation may also include licensing and zoning. Requiring motor vehicles to be equipped with a muffler or mandating that existing mufflers be retrofitted in order to reduce noise are examples of technical specifications. Technical specifications tend to be emphasized when noise emission standards technology does not exist or its cost is prohibitively expensive. Technical specifications, however, "are often fairly crude and inefficient."<sup>103</sup> Consequently, more and more reliance is placed on noise emission standards as technology and cost problems associated with their use are solved. Noise emission standards are more cost effective than technical specifications because they permit private decisionmakers to determine how they will comply, but they offer no incentives to those private decisionmakers to reduce their noise emissions below the level set by the noise emission standards. They also are dependent upon effective monitoring procedures. Whatever its form, direct regulation tends to be rigid and inflexible. Regulations, moreover, are difficult to change once they have been issued.

*b. Direct intervention.* Government can encourage education about noise and its effects. Government can finance noise research. Government can achieve operational modifications by lowering speed limits or rerouting traffic and can achieve trans-

Condition	Observed Difference (in dB(A))	
	British Study	Swiss Study
Open window	14	5 - 10
Closed window	25	15 - 25
Closed double window	45	20 - 35

OECD REPORT, *supra* note 41, at 61-62. A 50% reduction in the size of the windows reduces the noise level by 3 dB. *Id.* at 62.

102. For a discussion of the available "options" or "policy instruments," see NRC TRANSPORTATION STUDY, *supra* note 20, at 2-3; U.S. DEP'T OF COMMERCE, *supra* note 37, at 125-27.

103. NRC TRANSPORTATION STUDY, *supra* note 20, at 3.

mission path modifications by purchasing wider rights-of-way. In contrast to the scope of governmental activity with regard to other pollutants, however, "the scope for direct governmental activities in noise abatement programs seems to be relatively narrow."<sup>104</sup> Nothing, for example, plays the "central role" for noise that waste treatment plants do for water pollution.<sup>105</sup>

c. *Subsidies.* Subsidies could take a variety of forms: low-cost government loans, grants, demonstration projects, or tax incentives. A homeowner, for example, could receive a low-cost government loan in order to relocate his residence when he lives too close to a busy highway. Subsidies are rarely used, however, because of public opposition.<sup>106</sup>

d. *Financial incentives.* Financial incentives seek to internalize the social costs of noise. In the case of motor vehicle noise, each manufacturer or owner would be assessed a charge proportional to the noise emissions of his motor vehicle.

Each firm, aware of the full dollar costs of pollution, would then determine independently the level of noise it would produce, consistent with the goal of profit maximization. Each firm would abate noise up to the point where the marginal benefits (namely, smaller payments to the collecting agency) just equaled the additional costs of further noise abatement. Ideally, the money collected from the polluting source would be distributed as compensation payments to those who were being affected by noise the firms had decided to emit.<sup>107</sup>

Such a system of charges presupposes, however, a monitoring system that can identify the contribution of each individual noise source to total noise.

e. *Self-regulation.* Self-regulation has not proven successful in controlling other forms of pollution. Consequently, a considerable amount of pessimism exists as to the utility of self-regulation in the noise context.<sup>108</sup> Growing disenchantment with government regulation, however, is forcing a reevaluation of this option.<sup>109</sup>

---

104. *Id.* at 2.

105. *Id.* at 2-3.

106. See U.S. DEP'T OF COMMERCE, *supra* note 37, at 126.

107. *Id.* at 126-27.

108. See *id.* at 125.

109. See, e.g., AMERICAN BAR ASSOCIATION, *FEDERAL REGULATION: ROADS TO REFORM* (1978) (Exposure Draft of the Commission on Law and the Economy).



## SECTION II

### REGULATION OF TRAFFIC NOISE IN THE UNITED STATES

Noise was not frequently discussed in the United States until the 1960's. During that decade, awareness of and concern about the problems posed by noise increased dramatically.<sup>1</sup> The federal government responded to this growing public awareness and concern by enacting a series of statutes to control noise.<sup>2</sup>

Traffic noise was one category of noise that received special attention. In devising its program, the federal government envisioned a three-pronged attack on traffic noise. One phase of the program called for noise reduction at the source by means of federal noise emission standards. These federal noise emission standards apply to new motor vehicles and to in-use interstate motor carriers. Federal design noise levels for federal-aid highway projects were another phase of the program. These federal design noise levels guide state highway agencies in locating, planning, and designing such highways. The final phase of the program called for land-use regulation in the vicinity of highways. Land-use regulation traditionally has been and continues to be the responsibility of local governments.

This Section focuses on the first two phases of the program, describing and analyzing the laws and regulations that will be used to implement these two phases of the program. No attempt is made to examine any regulation in minute detail. Rather, those aspects of the regulations that are of interest from the standpoint of this comparative study are highlighted. Land-use regulation will be discussed only insofar as federal design noise levels impact on the regulation of land use.

---

1. One indication of the growing awareness of and concern about noise is the number of articles written on the subject in the 1960's. For example, vol. 13 of the *Index to Legal Periodicals*, covering the period Sept. 1961 to Aug. 1964, contains five articles specifically on noise. These articles are listed under one subject heading: Nuisance. In contrast, vol. 15 of the *Index to Legal Periodicals*, covering the period Sept. 1967 to Aug. 1970, contains 12 articles specifically on noise. These articles are listed under four subject headings: Environmental Control, Motor Vehicles, Nuisance, and Pollution.

2. In addition to the Noise Control Act of 1972, 42 U.S.C. §§ 4901-4918 (1976), the Noise Pollution and Abatement Act of 1970, 42 U.S.C.A. § 7641 (West Pamph. Supp. 1978), and the Federal-Aid Highway Act of 1973, 23 U.S.C. §§ 101-156 (1976), which are discussed in detail in this Section, the other federal statutes that contain provisions dealing with noise are the Federal Aviation Act of 1958, *see* 49 U.S.C. § 1431 (1976), the Federal Coal Mine Health and Safety Act of 1969, *see* 30 U.S.C. § 846 (1976), the National Environmental Policy Act of 1969, *see* 42 U.S.C. § 4331 (1976), and the Occupational Safety and Health Act of 1970, *see* 29 U.S.C. § 651 (1976)

A. *Noise Control Act of 1972*

The Noise Control Act of 1972 (NCA)<sup>3</sup> became the first comprehensive noise statute at the federal level. Section 2 of the NCA declares that the policy of the United States is "to promote an environment for all Americans free from noise that jeopardizes their health or welfare."<sup>4</sup> The NCA's enactment resulted from the realization that inadequately controlled noise constitutes a growing danger to public health and welfare, particularly in urban areas,<sup>5</sup> and expresses the congressional conclusion that uniformity of treatment requires regulation of major noise sources.<sup>6</sup>

Eight of the NCA's nineteen sections address themselves,

3. Pub. L. No. 92-574, 86 Stat. 1234 (codified in 42 U.S.C. §§ 4901-4918 (1976)).

For discussion of the NCA, see Cuadra, Sperry, & Roper, *Regulation of Transportation Noise in the United States*, 43 J. SOUND & VIBRATION 449 (1975); Comment, *Toward the Comprehensive Abatement of Noise Pollution: Recent Federal and New York City Noise Control Legislation*, 4 ECOLOGY L.Q. 109, 117-35 (1974) [hereinafter cited as *Recent Noise Control Legislation*].

4. 42 U.S.C. § 4901(b) (1976).

5. *Id.* § 4901(a)(1). "Noise—unwanted sound—is increasing in urban areas at a rate which may double the average person's exposure to it within 10 years." S. REP. NO. 1160, 92d Cong., 2d Sess. 1 (1972) [hereinafter cited as S. REP. 92-1160].

6. Major sources of noise include "transportation vehicles and equipment, machinery, appliances, and other products in commerce." 42 U.S.C. § 4901(a)(2) (1976). The intent of the Senate Committee on Public Works was that "vehicles or engines, or any components or accessories thereof, which are manufactured [or] modified for, or utilized exclusively in organized competitive off-highway motorsports events" or "church bells or carillons" not be designated major sources of noise. S. REP. 92-1160, *supra* note 5, at 6. The question of what products to designate as major noise sources was discussed by Senator John V. Tunney, the floor manager of the NCA in the Senate:

[B]oth the House and the Senate bill provided authority for the Administrator of the Environmental Protection Agency to establish noise emission standards for products. In general it is assumed the Administrator will deal with the products which contribute to noise in the environment, as distinguished from household products. This is not to say that the Administrator cannot regulate air conditioners. However, it is the intent of the Congress that priorities established by the Administrator would be directed toward such items as trucks, snowmobiles, motorcycles, compressors, and construction equipment, rather than blenders, electric can openers, and vacuum cleaners although standards could cover these items.

118 CONG. REC. 37,318-19 (1972).

The House report listed two alternatives to the NCA. One alternative would have been to have left the regulation of noise primarily to the states. This alternative was rejected because of the need for uniformity of treatment. In 1971 more than 100 noise bills had been introduced in 33 states. See 4 U.S. ENVIRONMENTAL PROTECTION AGENCY, PUBLIC HEARINGS ON NOISE ABATEMENT AND CONTROL 293 (1971) (statement of Raymond W. Lucia) [hereinafter cited as PUBLIC HEARINGS IV]. The other alternative would have been to have regulated ambient noise levels as well as emission noise sources. This alternative was rejected as unwarranted. H.R. REP. NO. 842, 92d Cong., 2d Sess. 33 (1972) [hereinafter cited as H.R. REP. 92-842].

directly or indirectly, to traffic noise. Six of these sections will be discussed under four headings; the remaining two sections will be discussed in conjunction with the enforcement of the NCA.

### 1. *Noise emission standards*

Before the regulations containing noise emission standards for new products (section 6) and interstate motor carriers (section 18) can be issued, section 5 requires the Administrator of the Environmental Protection Agency (EPA) to publish certain documents "after consultation with appropriate Federal agencies."<sup>7</sup> These documents are of three types: a noise criteria document, an ambient noise levels document, and one or more noise source reports.

a. *Section 5.* The Administrator's first responsibility was to develop and publish criteria for noise regulation within nine months of October 27, 1972,<sup>8</sup> the date on which the NCA was

---

7. Consultation is a frequently imposed requirement. *See, e.g.*, 42 U.S.C. §§ 4904(a)(1) (noise criteria), (a)(2) (information on ambient noise levels), (b) (noise source reports) (1976). Under the provisions of § 4904, the Administrator need only consult with "appropriate federal agencies." This requirement is rather narrow. Although this particular provision was never questioned during congressional debate of the NCA, a similar but broader provision which requires the Administrator of the Federal Aviation Administration to "consult with such federal, state, and interstate agencies as he deems appropriate" and which subsequently became § 4906(d)(2) of the NCA was questioned. 118 CONG. REC. 6041 (1972) (exchange between Congressmen Waggonner and Rogers).

8. Statutory deadlines appear with some frequency throughout the NCA. *See, e.g.*, 42 U.S.C. §§ 4904(a)(1) (noise criteria must be developed and published within nine months after Oct. 27, 1972), (a)(2) (information on ambient noise levels must be published within 12 months after Oct. 27, 1972), (b) (the first noise source report must be published within 18 months after Oct. 27, 1972), 4905(a)(2)(A) (proposed new product regulations must be issued within 18 months after Oct. 27, 1972), 4917(a)(1) (proposed interstate motor carrier noise emission regulations must be issued within nine months after Oct. 27, 1972) (1976). *House Report No. 842* explains the rationale for statutory deadlines with respect to federal noise emission standards:

Because of its finding that technology is available for the the control within adequate limits of noise emission of the majority of products which constitute major noise sources, the [House] committee [on Interstate and Foreign Commerce] determined that a time limit for the initiation of the standard setting process was proper and indeed essential to prevent the growth of the noise problem beyond reasonable limits.

H.R. REP. 92-842, *supra* note 6, at 7.

Officials at EPA are generally critical of these statutory deadlines. They consider them unrealistic. For example, 42 U.S.C. § 4916(a)(1) (1976) provides that the Administrator shall publish proposed railroad noise emission regulations within nine months after Oct. 27, 1972. One consultant with whom the author spoke felt that this deadline was impossible both because of the complexity of the railroad industry and because no comprehensive studies of railroad noise existed. EPA officials also fear the effect of missed deadlines. Missed deadlines undermine morale and shift the emphasis away from publishing a thorough and professional document to publishing a document which meets the



enacted, and thereafter, to review and when necessary revise or supplement these noise criteria.<sup>9</sup> The criteria were to reflect "scientific knowledge" and indicate "identifiable effects" on public health or welfare of "differing quantities and qualities of noise."<sup>10</sup> Noise criteria were developed and were published on July 27, 1973, in a document entitled *Public Health and Welfare Criteria for Noise*.<sup>11</sup>

The Administrator's next responsibility was to publish information on ambient noise levels<sup>12</sup> within twelve months after October 27, 1972.<sup>13</sup> Information on ambient noise levels was published in March 1974 in a document entitled *Information on Levels of Environmental Noise Requisite to Protect Public Health and Welfare with an Adequate Margin of Safety (Ambient Noise Levels Document)*.<sup>14</sup> These ambient noise levels are the levels which

---

deadline. Missed deadlines annoy Congress. See Letter from Nine Senators to Russell E. Train, Administrator, EPA, reprinted in *Noise Control Act Extension, Hearings on H.R. 5272 Before the Subcomm. on Transportation and Commerce of the House Comm. on Interstate and Foreign Commerce, 94th Cong., 1st Sess. 53 (1975)* [hereinafter cited as *NCA Extension Hearings*]. Missed deadlines also encourage lawsuits. On July 2, 1974, PROD, the Professional Drivers Council for Safety and Health, filed suit against EPA, charging EPA with failing to meet its responsibilities under 42 U.S.C. § 4905(a)(2)(A) (1976) (proposed new product regulations) and demanding that EPA meet its mandated responsibilities.

9. 42 U.S.C. § 4904(a)(1), (c) (1976). The publication or revision of noise criteria are announced in the *Federal Register*. Copies of the criteria also are made available to the public. *Id.* § 4904(d).

10. *Id.* § 4094(a)(1).

11. U.S. ENVIRONMENTAL PROTECTION AGENCY, DOC. NO. 550/9-73-002, PUBLIC HEALTH AND WELFARE CRITERIA FOR NOISE (1973).

12. The NCA uses "environmental noise levels" rather than the more commonly used "ambient noise levels." Environmental noise is defined as "the intensity, duration, and the character of sounds from all sources." 42 U.S.C. § 4902(11) (1976). Since "environmental noise levels" and "ambient noise levels" mean the same thing, ambient noise, the more commonly used term, will be used throughout this comparative study.

13. *Id.* § 4904(a)(2). Some confusion exists as to whether the Administrator has a responsibility to review and, when necessary, revise or supplement the information on ambient noise levels. Compare *id.* § 4904(c) (responsibility) with *id.* § 4904(d) (arguably no responsibility).

The publication and revision, if any, of ambient noise levels are announced in the *Federal Register*. Copies of these ambient noise levels also are available to the public. *Id.* § 4904(d).

14. U.S. ENVIRONMENTAL PROTECTION AGENCY DOC. NO. 550/9-74-004, INFORMATION ON LEVELS OF ENVIRONMENTAL NOISE REQUISITE TO PROTECT PUBLIC HEALTH AND WELFARE WITH AN ADEQUATE MARGIN OF SAFETY (1974) [hereinafter cited as AMBIENT NOISE LEVELS DOCUMENT].

In the *Ambient Noise Levels Document*, EPA adopted two sound level measures,  $L_{eq}$  and  $L_{dn}$ .  $L_{eq}$  is a constant level, expressed in dB(A), which, in a given situation and during a given time period, conveys the same sound energy as would be conveyed by actual sound levels. For example, two sounds, one of which contains twice as much energy but lasts only half as long as the other, would have the same  $L_{eq}$ . EPA uses  $L_{eq}$  as an indicator

must be attained and maintained in "defined areas"<sup>15</sup> and under "various conditions"<sup>16</sup> in order to protect public health and welfare "with an adequate margin for safety."<sup>17</sup>

The Administrator's final responsibility under section 5 was to compile and publish noise source reports,<sup>18</sup> beginning within eighteen months of October 27, 1972, and thereafter, to review and when necessary revise or supplement these noise source reports.<sup>19</sup> Noise source reports have two functions. They identify "products (or classes of products) which in [the Administrator's] judgment are major sources of noise, and (2) [give] information on techniques for control of noise from such products, including available data on the technology, costs, and alternative methods of noise control."<sup>20</sup>

Two products—medium and heavy-duty trucks and portable air compressors—were identified by EPA as major noise sources on June 19, 1974.<sup>21</sup> EPA initially acknowledged that there was no universally accepted method of determining noise sources which

of long-term hazard to hearing.  $L_{dn}$  primarily measures speech interference caused by noise in residential areas. EPA uses  $L_{dn}$  as an indicator of long-term annoyance. AMBIENT NOISE LEVELS DOCUMENT, *supra* at 10-12, app. A.

EPA's attempts to encourage other federal agencies to adopt  $L_{eq}$  and  $L_{dn}$  as sound level measures were rebuffed by the Department of Transportation. See Letter from Claude S. Brinegar, Secretary, Dep't of Transportation, to Russell E. Train, Administrator, EPA, reprinted in *NCA Extension Hearings*, *supra* note 8, at 12.

Based on information available in 1973, EPA concluded that the requisite ambient noise levels are 70 dB(A) to avoid hearing loss, 55 dB(A) to avoid outdoor interference and annoyance, and 45 dB(A) to avoid indoor interference and annoyance. AMBIENT NOISE LEVELS DOCUMENT, *supra* at 3. All of these values are based on a twenty-four hour exposure. For the yearly average equivalent sound levels identified by EPA as requisite to protect public health and welfare with an adequate margin of safety, see AMBIENT NOISE LEVELS DOCUMENT, *supra* at 29.

15. Four areas have been defined: outdoor areas where people spend varying amounts of time, outdoor areas where people spend limited amounts of time, indoor residential areas, and other indoor areas where human activities take place. AMBIENT NOISE LEVELS DOCUMENT, *supra* note 14, at 3.

16. In addition to the varying conditions existing in the defined areas, the *Ambient Noise Levels Document* draws a distinction between daytime and nighttime noise.

17. According to EPA, "the margin of safety has been developed through the application of a conservative approach at each stage of the data analysis. The cumulation of these results thus provides for the adequate margin of safety." AMBIENT NOISE LEVELS DOCUMENT, *supra* note 14, at foreword-2.

18. 42 U.S.C. § 4904(b) (1976) provides that the Administrator is to compile and publish "a report or series of reports."

19. 42 U.S.C. § 4904(c) (1976). The publication or revision of noise reports is announced in the *Federal Register*. *Id.* § 4904(d). Although copies of *Public Health and Welfare Criteria for Noise* and the *Ambient Noise Levels Document* are to be made available to the public, there is no comparable provision with regard to noise reports. *Id.*

20. *Id.* § 4904(b).

21. 39 Fed. Reg. 22,297 (1974).

pose a threat to public health and welfare<sup>22</sup> and then outlined the methodology it had used.<sup>23</sup>

Six additional products were identified by EPA as major noise sources on May 20, 1975, and an announcement to this

---

22. In determining which noise sources pose a threat to public health and welfare, a variety of factors must be considered:

These factors include the frequency characteristics of the products operating, the length of time each product operates, the proximity of people to the products, the time of day or other situational variables, the presence of other noise sources, and the degree to which the people exposed to the product can control the product and/or its sound emission.

*Id.*

23. EPA's first step was to determine that priority should be given to sources that are major contributors to community noise. In making this determination, EPA used  $L_{dn}$  to identify "residential areas where a large number of people are exposed to high day-night sound levels" and discovered the major contributors to community noise were of four types: urban traffic noise, aircraft noise, construction site noise, and freeway noise. See *id.* at 22,298.

EPA's next step was to determine whether to regulate products in one or more of the four categories permitted by the NCA. See 42 U.S.C. § 4905(a)(1)(C) (1976). For a discussion of these four categories of products, see notes 34-36 and accompanying text *infra*. EPA chose to regulate products in the transportation equipment and construction equipment categories. These two categories were chosen because of "the extensive community exposure to noise emanating from products in these categories." 39 Fed. Reg. 22,298 (1974). Each product in these two categories was measured in terms of typical sound level expressed in dB(A) at 50 ft./15.2 m., and estimated sound energy, expressed in KWh/day.

Using the foregoing methodology, EPA designated medium and heavy-duty trucks, which had the second highest typical sound level and the highest estimated total sound energy, as a major source of transportation equipment noise. See *id.* U.S. ENVIRONMENTAL PROTECTION AGENCY, DOC. NO. 550/9-74-018, PRELIMINARY COST AND TECHNOLOGY ON MEDIUM AND HEAVY DUTY TRUCKS (1974) [hereinafter cited as TRUCK COST AND TECHNOLOGY DOCUMENT] was published in conjunction with the noise source report designating medium and heavy-duty trucks as a major source of transportation equipment noise and summarized existing information on trucks of this type.

The *Truck Cost and Technology Document* is divided into five sections and an appendix. Section 2 outlines five ways in which trucks can be classified. They can be classified in terms of design: long haul, construction, or general delivery. They can be classified in terms of cab style: conventional, cab, or cab-over-engine. They can be classified in terms of drive line: 2 X 4, *i.e.*, 2 of 4 wheels drive the truck, 4 X 4, 4 X 6, or 6 X 6. They can be classified in terms of weight: medium duty, consisting of classes 3 (10,000-14,000 GVWR), 4 (14,001-16,000 GVWR), 5 (16,001-19,500 GVWR), and 6 (19,501-26,000 GVWR); or heavy duty consisting of classes 7 (26,991-33,000 GVWR) and 8 (over 33,000 GVWR). They can be classified in terms of engine type: gasoline or diesel. TRUCK COST AND TECHNOLOGY DOCUMENT, *supra* at 3-8.

Section 3 gives the noise characteristics of trucks currently in production. For example, the mean noise level for 384 new diesel trucks was 84.7 dB(A). Approximately 1% of the new diesel trucks rated 80 dB(A) or less and 30% rated under 83 dB(A). The 384 new diesel trucks included models from eight manufacturers. These models account for 85% of the diesel trucks sold in 1972. TRUCK COST AND TECHNOLOGY DOCUMENT, *supra* at 11.

Section 4 discusses the contribution of various components to total truck noise, and section 5 discusses total truck noise. In 1972 component total noise levels combined to produce trucks with a total noise level of 86 dB(A).

effect appeared in the *Federal Register* on May 28, 1975.<sup>24</sup> These products included motorcycles, buses, wheel-and-truck loaders, truck-transport refrigerator units, and truck-mounted solid waste compactors. The announcement identifying these products as major noise sources also contained a table listing seventy-five products in six categories as possible candidates for regulation.<sup>25</sup>

In late 1976 and early 1977 EPA identified three more products as major sources of noise. Power lawnmowers were so identified on December 30, 1976, and an announcement to this effect appeared in the *Federal Register* on January 12, 1977.<sup>26</sup> Pavement breakers and rock drills were so identified on January 19, 1977, and an announcement to this effect appeared in the *Federal Register* on February 3, 1977.<sup>27</sup>

b. *Section 6: regulation of noise sources.* Section 6 has been described as the "major regulatory thrust"<sup>28</sup> of the NCA and requires the Administrator to issue regulations for products<sup>29</sup> dis-

24. 40 Fed. Reg. 23,105 (1975). The announcement identifying these six products as major noise sources indicated that noise source reports for the products "will be published in advance of rulemaking." *Id.* at 23,107.

25. The list included such diverse products as helicopters, lawn edgers, and electric shavers. *Id.* at 23,106-07.

The announcement indicated that the possibility of automobile regulation was being studied. However, immediate regulation of automobiles was determined to be infeasible because of "[t]he size and complexity of the automotive industry and the extensive effort necessary to adequately evaluate cost and available technology." *Id.* at 23,107. EPA, moreover, has apparently concluded that the present noise level of automobiles—73-75 dB(A)—cannot be reduced through the application of "best available technology" in the near future. *See Recent Noise Control Legislation, supra* note 3, at 123-24.

26. 42 Fed. Reg. 2525 (1977).

27. *Id.* at 6722.

28. S. REP. 92-1160, *supra* note 5, at 5.

29. The NCA defines "product" as "any manufactured article or goods or component thereof." 42 U.S.C. § 4902(3) (1976). Aircraft and related components, military weapons or equipment designed for combat use, rockets or equipment designed for experimental use by the National Aeronautics and Space Administration, and certain machinery or equipment designed for experimental use by the federal government do not fall within this definition. 42 U.S.C. § 4902(3)(A), (B) (1976).

Section 6 regulations apply to new products:

The standards would cover new products, those which had never before been sold to a consumer, which are manufactured after the effective date of the standards. Remanufactured and rebuilt products whose original functions have been restored by a manufacturer are defined as new products. However, noise emission standards are to be established for such rebuilt products on the basis of what can be achieved for products of that class, i.e., rebuilt products, and not what is being required of newly manufactured products of a similar type.

S. REP. 92-1160, *supra* note 5, at 5.

The NCA defines a "new product" as

(A) a product the equitable or legal title of which has never been transferred to an ultimate purchaser, or (B) a product which is imported or offered for impor-

tributed in interstate commerce.<sup>30</sup> These regulations must include "a noise emission standard which shall set limits on noise emissions from such product [and] may contain testing procedures necessary to assure compliance with the emission standard" and "provisions respecting instructions of the manufacturer for the maintenance, use, or repair of the product."<sup>31</sup>

In establishing federal noise emission standards, the Administrator is to consider "the magnitude and conditions of use of such a product (alone or in combination with other noise sources), the degree of noise reduction achievable through the application of the best available technology, and the cost of compliance."<sup>32</sup>

---

tation into the United States and which is manufactured after the effective date of a regulation under § 4905 [new product regulation] or § 4907 [labeling] of this title which would have been applicable to such product had it been manufactured in the United States.

42 U.S.C. § 4902(5) (1976).

30. The NCA defines "commerce" as "trade, traffic, commerce, or transportation . . . between a place in a State and any place outside thereof, . . . which affects trade, traffic, commerce, or transportation . . . 42 U.S.C. § 4902(7) (1976). "Distribute in commerce" is defined as "[selling] in, [offering] for sale in, or [introducing] or [delivering] for introduction into, commerce." *Id.* § 4902(8).

31. *Id.* § 4905(c)(1).

32. *Id.* The House of Representatives and the Senate disagreed on the proper basis for the federal noise emission standards. The approach adopted by the House called for the standards to be based primarily on public health and welfare and secondarily on best available technology and cost of compliance. The Senate, however, felt that public health and welfare should not be part of the basis of the federal noise emission standards and recommended an approach based exclusively on best available technology and cost of compliance:

The difficulty of relating noise emissions from a given source to effects on public health and welfare in an enforceable way, when standards are to be set on a national basis without control of the circumstances of use or the number of products in a given area, led the Committee to conclude that implementation of a technologically-based standard was preferable in terms of uniformity and enforceability to one calling for protection of the public health and welfare. While the intention of the whole bill is to protect public health and welfare from environmental noise, the Committee expects that the application of the best available technology will just begin to realize that goal in the foreseeable future.

S. REP 92-1160, *supra* note 5, at 6-7.

The approach proposed by the House of Representatives prevailed. In discussing this aspect of the NCA, Senator John V. Tunney, floor manager of the NCA in the Senate, made the following statement:

The Senate bill assumed that the best technology available would probably not be adequate to assure protection of public health and welfare and thus that the levels of noise reduction which could be achieved with technology would be the minimum level of control. Under the House amendment, the application of the best available technology remains the minimum standard, by providing for the establishment of standards based on both public health and welfare and the technology available for noise reduction.

118 CONG. REC. 37,319 (1972).

The Administrator is also to give "appropriate consideration" to other standards established to protect public health and welfare.<sup>33</sup>

One of two procedures is used. One procedure is reserved for products which fall into one of four categories—(1) construction equipment, (2) transportation equipment,<sup>34</sup> (3) any motor or engine,<sup>35</sup> and (4) electrical or electronic equipment—which have been identified in a published noise source report as a major source of noise, and for which noise emission standards are feasible.<sup>36</sup> Proposed regulations were to be issued within eighteen months of October 27, 1972, for products satisfying these three requirements.<sup>37</sup> If a noise source report identifying a product as a major noise source was not included with the initial proposed regulations but is subsequently published, proposed regulations for that product are to be issued within eighteen months after the noise source report is published.<sup>38</sup> Proposed regulations were to become final not earlier than six months after issuance nor later than twenty-four months after either October 27, 1972 (products which have been identified as a major noise source in a published noise source report), or the publication of a noise source report (products for which no noise source report has been published), unless the Administrator determined that regulations were not feasible.<sup>39</sup>

An alternative procedure applies to "any product" for which noise emission standards are "feasible" and are "requisite" to protect public health and welfare.<sup>40</sup> If the product satisfies these

---

Consideration of best available technology and cost of compliance raises two issues: (1) What meaning should be given to the term "available" and (2) how much weight should be given to the cost of compliance? For a discussion of how these issues ought to be resolved, see *Recent Noise Control Legislation*, *supra* note 3, at 119-23. For a discussion of how the Office of Noise Abatement and Control actually resolved these issues, see notes 100-02, 224-26 and accompanying text *infra*.

33. 42 U.S.C. § 4905(c)(1) (1976). These standards include, but are not limited to, standards under the National Traffic and Motor Vehicle Safety Act of 1966, see 15 U.S.C. § 1381 (1976), and the Clean Air Act, see 42 U.S.C. §§ 1857-1858a (1976).

34. "Transportation equipment" includes "recreational vehicles and related equipment." 42 U.S.C. § 4905(a)(1)(C)(ii) (1976).

35. "Any motor or engine" includes "any equipment of which an engine or motor is an integral part." *Id.* § 4905(a)(1)(C)(iii).

36. *Id.* § 4905(a)(1).

37. *Id.* § 4905(a)(2)(A).

38. *Id.* § 4905(a)(2)(B).

39. *Id.* § 4905(a)(3).

40. *Id.* § 4905(b). The Administrator has the responsibility of determining not only whether noise emission standards are "feasible" but also whether they are "requisite" to protect public health and safety. Apparently, both requirements must be satisfied if the alternative procedure of issuing regulations is to be used.

requirements, proposed regulations can be issued at any time.<sup>41</sup> They become final not earlier than six months after issuance.<sup>42</sup>

After proposed regulations have been issued, the Administrator is required to permit "interested persons"<sup>43</sup> to participate in the rulemaking procedure.<sup>44</sup> Regulations can be revised by issuing the proposed revision, waiting six months, and then issuing the final regulations.<sup>45</sup> No six-month waiting period is imposed in cases involving "technical or clerical corrections."<sup>46</sup>

Section 6 also requires manufacturers<sup>47</sup> of new products<sup>48</sup> to which regulations apply to warrant to the ultimate purchaser<sup>49</sup> and each subsequent purchaser<sup>50</sup> that the "product is designed, built and equipped so as to conform at the time of sale with such regulation."<sup>51</sup> Any costs associated with this warranty are to be borne by the manufacturer.<sup>52</sup>

41. Section 4905(b) proposed regulations differ from § 4905(a)(2)(A) proposed regulations in this respect. See note 37 and accompanying text *supra*.

42. 42 U.S.C. § 4905(b) (1976).

43. The NCA does not define "interested persons."

44. 42 U.S.C. § 4905(c)(2) (1976). Although the NCA only speaks of public participation in the rulemaking procedure, EPA has opted to permit public participation in the formulation of proposed regulations. See, e.g., note 220 and accompanying text *infra*.

45. 42 U.S.C. § 4905(c)(3) (1976).

46. *Id.* However, the Administrator must find that earlier issuance is in the public interest in order to dispense with the six-month waiting period.

47. The NCA defines "manufacturer" as "any person engaged in the manufacturing or assembling of new products, or the importing of new products for resale, or who acts for, and is controlled by any such person in connection with the distribution of such products." 42 U.S.C. § 4902(6) (1976).

48. See note 29 *supra*.

49. The NCA defines "ultimate purchaser" as "the first person who in good faith purchases a product for purposes other than resale." 42 U.S.C. § 4902(4) (1976).

50. The NCA does not define "subsequent purchaser." However, subsequent purchasers must be all purchasers who purchase the product either from the "ultimate purchaser" or another "subsequent purchaser."

51. 42 U.S.C. § 4905(d)(1) (1976).

The NCA did not but should have defined the meaning of "time of sale." Several interpretations are possible. Time of sale might be the date when the manufacturer sells the product to a dealer who subsequently resells the product. Alternatively, time of sale might mean the date when the ultimate purchaser purchases the product.

The warranty requirement of the NCA is similar to the warranty requirement of the Clean Air Act. See 42 U.S.C. §§ 1857f-1858a (1976); 118 CONG. REC. 37,318 (1972). The warranty is a "useful life" and a "defects" warranty. "Useful life is to be determined by the Administrator, taking into account the range of uses to which such product might be put." S. REP. 92-1160, *supra* note 5, at 7. The manufacturer does not warrant that the product will meet the noise emission standards throughout its useful life. He is only liable for those changes in noise emission which are within his control. *Id.*

For a discussion of this warranty as it will apply to new medium and heavy-duty trucks, see notes 354-60 and accompanying text *infra*.

52. 42 U.S.C. § 4905(d)(2) (1976). Section 4905(d)(2) specifically prohibits "[t]he transfer of any . . . cost obligation from a manufacturer to any dealer through franchise or other agreement."

c. *Section 6: preemption problems.* During the hearings which were held prior to the enactment of the NCA, no issue was more hotly debated than the extent to which federal law would preempt state and local law. Nicholas C. Yost, Deputy Attorney General of California, spoke for those who opposed federal preemption. He took the position that “[the NCA] should adopt a . . . floor, not a . . . ceiling, for noise standards.”<sup>53</sup> Mr. Yost argued that federal preemption is undesirable because “a considerable amount of [existing state and local] legislation . . . might be preempted by the proposed [NCA].”<sup>54</sup> He argued that state and local governments need the authority to adopt their own noise laws because (1) “people in different jurisdictional entities have different values,”<sup>55</sup> (2) “[s]tate and local governments are more responsive to community needs than is the Federal Government,”<sup>56</sup> and (3) “removing the power to better our environmental conditions from California to Washington will demoralize those who work hard at the State and local level to secure enactment of good legislation.”<sup>57</sup> Quoting the second Annual Report of the President’s Council on Environmental Quality, Mr. Yost argued that “[s]tates are experimental laboratories for a variety of solutions to common problems” and that “[s]tate innovation frequently sets a precedent for Federal action.”<sup>58</sup> He also asserted that the arguments for federal preemption are invalid:

The arguments for preemption are not made by the advocates of more stringent abatement of noise pollution. They are made by manufacturers who dislike the multiplicity of levels that confront them in the diverse nation. Their arguments concerning the burden created for them by different standards seem

---

53. PUBLIC HEARINGS IV, *supra* note 6, at 260 (statement of Nicholas C. Yost).

54. *Id.* at 265.

55. *Id.* The validity of this argument has been subsequently attacked on the basis that differences in local preference presuppose freedom of informed choice when, in fact, such freedom does not exist. See NATIONAL RESEARCH COUNCIL ANALYTICAL STUDIES FOR THE USEPA, NOISE ABATEMENT: POLICY ALTERNATIVES FOR TRANSPORTATION 21 (1977) [hereinafter cited as NRC TRANSPORTATION STUDY].

56. PUBLIC HEARINGS IV, *supra* note 6, at 266 (statement of Nicholas C. Yost).

57. *Id.*

58. *Id.* Robert Moretti, Speaker of the California Assembly, raised this same point in a letter to Senator John V. Tunney. He proposed that California be permitted to set stricter noise emission standards. He justified this proposal on the ground that just as “California became the technological and environmental laboratory for the nation in regard to the fight against air pollution, so too it can become the laboratory for the fight against noise pollution.” Letter from Assemblymen Robert Moretti and Frank Lauterman to Senator John V. Tunney (Apr. 7, 1972), reprinted in *Noise Control Act of 1971 and Amendments, Hearings on S. 1016, S. 3342, H.R. 11021 Before the Subcomm. on Air and Water Pollution of the Senate Comm. on Public Works*, 92d Cong., 2d Sess. 108 (1972).



specious. Nobody is telling a manufacturer that he must sell in any particular state. If he wants to sell there, he can meet the standards the people of the State choose to adopt. As a practical matter no State or locality will set a standard so low that the necessary item cannot be sold. If that item can be made quieter, why should not the people of that State be enabled to insist upon it?<sup>59</sup>

Thomas E. Carroll, Assistant Administrator for Planning and Management, EPA, spoke for those who favored federal preemption. He took the position that the issue of federal preemption had been settled in the development of the auto emission standards under the Clean Air Act:

At that time, industry argued, and justifiably we feel, that it would be impossible to continue the mass production techniques and still meet a variety of varying State and local regulations. The Congress which makes the law—not EPA—agreed with this position and called for national standards, giving California which has a unique problem the right to a waiver. I think that we are going to see the same precedent—minus any waiver—followed in the development of the Federal noise control legislation.<sup>60</sup>

Mr. Carroll maintained that the real reason for raising the preemption issue was “a fear that EPA will not set tough enough standards or, having set them, fail to enforce them with vigor.”<sup>61</sup> He argued that “[s]uch a fear belies [EPA’s] record and is unfounded.”<sup>62</sup>

Congress found the arguments of the proponents of federal preemption more persuasive than the arguments of the opponents. Accordingly, section 6 distinguishes between noise controls imposed on the source and noise controls imposed on its use.<sup>63</sup> “Source” controls are the responsibility of the federal government. These controls will take the form of noise emission standards and will preempt state and local noise emission standards, *i.e.*, state and local noise emission standards for new products

59. PUBLIC HEARINGS IV, *supra* note 6, at 266 (statement of Nicholas C. Yost).

60. *Id.* at 32 (statement of Thomas E. Carroll). The National Research Council subsequently articulated four disadvantages of the state and local option: (1) lack of uniformity, (2) competitive disadvantage, (3) cost of the noise regulation program, and (4) constitutional questions about the rights of state and/or local governments to impose standards on sister states and/or local governments. NRC TRANSPORTATION STUDY, *supra* note 55, at 21-23.

61. PUBLIC HEARINGS IV, *supra* note 6, at 33 (statement of Thomas E. Carroll).

62. *Id.*

63. S. REP. 92-1160, *supra* note 5, at 7.

must be identical to the federal noise emission standards.<sup>64</sup> States

---

64. 42 U.S.C. § 4905(e)(1)(A) (1976). The NCA differs from other environmental legislation in requiring that state and local noise emission standards must be identical to federal noise emission standards. For example, the Clean Air Act, see 42 U.S.C. §§ 1857-18571 (1976), allows a state or any political subdivision thereof to adopt and enforce emission standards or limitations which are not identical to the federal emission standards or limitations.

Federal preemption of state and local law with respect to noise emission standards was a controversial proposal during debate of the NCA. The practice was defended by Senators Tunney, 118 CONG. REC. 35,387 (1972), and Randolph, *id.* at 35,411-12, and by Congressman Staggers, *id.* at 6036-37. Senator Muskie, *id.* at 35,417-18, and Congressman Brotzman, *id.* at 6041, Mikva, *id.* at 6044, Ryan, *id.* at 6045, and Drinan, *id.* at 6046, criticized the practice.

Senator Tunney favored federal preemption. He subsequently articulated his position in a law review article. See Tunney, *Regulation—Local, State and Federal*, 7 NAT. RESOURCES LAW 301 (1974). Senator Muskie opposed federal preemption. He articulated his position as a minority view in *Senate Report No. 1160*:

The [Senate] bill does not, however, provide adequate options in those cases in which best available technology is not adequate to achieve environmentally acceptable levels of noise. It does not recognize adequately the responsibility of States and local government to protect the environment in which their citizens live. It does not assure States an opportunity to ban the sale of Federally-regulated products which emit unacceptable levels of sound. At the same time, it does not expedite Federal regulation, thus holding out the hope of a quieter environment with no guarantee of early environmental improvement.

The [Senate] Committee on Public Works is not unfamiliar with the problem of preemption. The Air Quality Act of 1967 . . . provided for Federal preemption of the authority to regulate air pollution emissions from new automobiles . . . . It appears that the preemption provisions of the Act did not cause the auto companies to focus their research efforts on investments on one set of national standards. Rather, the auto companies' efforts have been focused on undermining those national standards.

Section 231(a) of the Clean Air Act requires that the Environmental Protection Agency must begin an investigation of air pollution from aircraft within 90 days of date of enactment. Within 180 days after commencing that investigation, [EPA] is required to report on the investigation and propose emission standards . . . . Today, no report or proposed standards have been published.

The States have moved actively in [the noise] field. Federal noise pollution responsibility is new and little significant authority or responsibility exists. Conversely, a number of States have regulatory programs which impose emission controls on noisy products which controls are enforceable, both at the point of sale and the point of use.

I cannot support Federal preemption which protects product manufacturers and the air transportation industry without effective regulatory programs which will enhance the quality of the environment. Substitution of Federal law for State law without assurance that public health will be protected is poor public policy.

S. REP. 92-1160, *supra* note 5, at 21-22.

The NCA explicitly provides that state and local noise emission standards must be identical to federal noise emission standards. A question left unresolved by the language

and localities have no authority to establish or enforce noise emission standards for components incorporated into a new product.<sup>65</sup>

"Use" controls, however, are the responsibility of state and local governments.<sup>66</sup> They may take a number of forms, such as:

- (a) operational limits or regulations on products and use (such as speed or load limits or prohibitions of use in given areas or during given hours);
- (b) quantitative limits on environmental noise in a given area which may be enforced against any source within the area, including zones adjacent to streets and highways;
- (c) regulations limiting the environmental noise which may exist at the boundary of a construction site;
- (d) nuisance laws; or
- (e) other devices tailored to the needs of differing localities and land uses which do not amount to a burden manufacturers must meet to continue in business.<sup>67</sup>

Under this allocation of responsibility, state and local governments retain the authority to establish and enforce ambient noise levels.<sup>68</sup>

Section 6 assumes that protection of the environment and federal preemption of state and local laws are mutually compatible goals. This assumption, however, is subject to question. Suppose, for example, that (1) EPA establishes a noise emission standard for motor vehicles of 83 dB(A), (2) state X either has already established or proposes to establish an ambient noise level of 70 dB(A), and (3) this ambient noise level cannot be achieved without modifying the motor vehicle. In this hypothetical situation the noise emission standard and the ambient noise level overlap. They are not separate, distinct, and hence, mutually compatible as section 6 assumes.

State X's ambient noise level effectively prohibits the use of *all* motor vehicles, even though those motor vehicles comply with

---

of the NCA is whether state and local testing procedures and maintenance, use, or repair instructions must also be identical to their federal counterparts. See note 31 and accompanying text *supra*. EPA's Office of Noise Abatement and Control answers this question affirmatively. See notes 361-65 and accompanying text *infra*.

65. 42 U.S.C. § 4905(e)(1)(B) (1976).

66. S. REP. 92-1160, *supra* note 5, at 7-8.

67. *Id.* at 8.

68. 42 U.S.C. § 4905(e)(2) (1976). State and local governments can establish and enforce ambient noise levels "through licensing, regulation, or restriction on the use, operation or movement of any product or combination of products." *Id.* In permitting state and local governments to establish and enforce ambient noise levels, Congress was attempting to strike a balance between federal regulation on the one hand and state and local control on the other hand. The difficulties inherent in such an approach are illustrated by the colloquy between Congressmen Eckhart and Rogers. See 118 CONG. REC. 6041-42 (1972).

EPA's noise emission standard.<sup>69</sup> Nothing in section 6 expressly prohibits this incongruous result. One could argue that state X's ambient noise level is consistent with section 6 and should be allowed. A more persuasive argument, however, is that state X's ambient noise level is inconsistent with the implied assumption in section 6 that EPA is the entity charged with issuing the regulations which will protect public health and welfare.

EPA will have to develop its own tests for resolving conflicts between use controls and source controls. The test probably will be one of significant impact. In the hypothetical situation, for example, state X's ambient noise level would have a significant impact because it would require equipment modification. Such use controls are really source controls in disguise.<sup>70</sup>

*d. Section 18.* In addition to section 6, which regulates new products, the NCA also contains section 18, which regulates interstate motor carriers.<sup>71</sup> Section 18 was not a part of the legislation originally introduced in Congress but was added at the behest of the interstate motor carrier industry in the Senate before enactment.<sup>72</sup>

Section 18 divides regulatory responsibilities between the Administrator and the Secretary of Transportation. The Administrator was required to issue proposed noise emission regulations and standards within nine months of October 27, 1972.<sup>73</sup> The Administrator was required to issue final noise emission regulations within ninety days after the proposed noise emission regulations were issued.<sup>74</sup> Noise emission regulations are subject to periodic revision.<sup>75</sup> Before issuing or revising noise emission regulations, the Administrator consults with the Secretary of Transpor-

---

69. EPA personnel were willing to concede that state and local governments could avail themselves of "use" controls. They were not prepared, however, to permit use controls to be implemented so as to prohibit use. See, e.g., PUBLIC HEARINGS IV, *supra* note 6, at 37-38 (statement of Thomas E. Carroll). Mr. Carroll characterized non-use as unrealistic. *Id.* at 38.

70. The suggestion has been made that use controls masquerading as source controls be permitted if the use control is limited to small areas or during certain hours. See *Recent Noise Control Legislation*, *supra* note 3, at 135.

71. The NCA adopts the definitions of "common carrier by motor vehicle," "contract carrier by motor vehicle" and "private carrier of property by motor vehicle" found in the Interstate Commerce Act. See 49 U.S.C. § 303 (1976).

72. H.R. 11021, 92d Cong., 2d Sess. (1972) contained no provision for federal noise emission standards for interstate motor carriers. See H.R. REP. 92-842, *supra* note 6, at 11-20. S. 3342, 92d Cong., 2d Sess. (1972) did contain such a provision. See S. REP. 92-1160, *supra* note 5, at 15-19.

73. 42 U.S.C. § 4917(a)(1) (1976).

74. *Id.* § 4917(a)(2).

75. *Id.*

tation to ascertain "safety" and "technological availability."<sup>76</sup>

The Administrator and the Secretary share joint responsibility for determining when the noise emission regulations become effective.<sup>77</sup> After this determination has been made, the Secretary consults with the Administrator<sup>78</sup> and issues regulations insuring compliance with the Administrator's noise emission standards.<sup>79</sup> These compliance regulations are authorized by the Interstate Commerce Act<sup>80</sup> and the Department of Transportation Act.<sup>81</sup>

Section 18, like section 6, distinguishes between source controls and use controls. Source controls are the responsibility of the federal government. They will take the form of noise emission standards and will preempt state and local noise emission standards, *i.e.*, state and local noise emission standards for interstate motor carriers must be identical to federal noise emission standards.<sup>82</sup> Consequently, the authority of state and local governments in the area of source controls is very limited.

State and local governments do have the authority to establish and enforce ambient noise levels<sup>83</sup> or "to control, license, regulate, or restrict the use, operation, or movement of any product."<sup>84</sup> However, section 18 use controls, unlike section 6 use controls, are subject to a determination by the Administrator, after consultation with the Secretary of Transportation, that these controls "[are] necessitated by special local conditions and [are] not in conflict with regulations promulgated under this section."<sup>85</sup>

The same tension between local environmental protection

76. *Id.* § 4917(a)(3).

77. *Id.* § 4917(a)(4). A period should be chosen which permits "the development and application of the requisite technology" and gives "appropriate consideration to the cost of compliance within such period." *Id.*

78. *Id.* § 4917(b).

79. *Id.*

80. *See* 49 U.S.C. §§ 301-327 (1976).

81. *See* 49 U.S.C. §§ 1651-1659 (1976).

82. 42 U.S.C. § 4917(c)(1) (1976).

83. *Id.* § 4917(c)(2).

84. *Id.*

85. *Id.* Section 4917(c)(2) should be disjunctive rather than conjunctive. The Senate considered and passed S. 3342 on Oct. 3, 1972. *See* 118 CONG. REC. 35,886 (1972). Section 523 of S. 3342, which was later to become § 4917(c)(2) of the NCA, was disjunctive rather than conjunctive. *See* 118 CONG. REC. 35,881-82 (1972). The Senate subsequently substituted the language of S. 3342 for the language of H.R. 11021 and sent the bill back to the House of Representatives, which had considered and passed H.R. 11021 on Feb. 29, 1972. *See* 118 CONG. REC. 6065 (1972). The disjunctive "or" became a conjunctive "and" when the House moved to concur in the Senate amendment but substituted its own language for the language of S. 3342. *See* 118 CONG. REC. 37,075 (1972).

and federal preemption which exists in section 6 is also found in section 18. The tension may be even greater in section 18 because state and local governments were already regulating interstate motor carriers when the NCA was enacted.<sup>86</sup>

There are, however, several significant differences between section 18 and section 6. The basis for the noise emission standards is different. The noise emission standards in section 18 are based solely on "best available technology" and "cost of compliance."<sup>87</sup> In contrast, the noise emission standards in section 6 are based primarily on "public health and welfare" and only secondarily on "best available technology" and "cost of compliance."<sup>88</sup> The scope of the noise emission standards is also different. Section 6 applies to new products.<sup>89</sup> Section 18 applies to in-use products.<sup>90</sup>

A number of regulations issued pursuant to the authorizations contained in sections 6 and 18 have thus far appeared: Interstate Motor Carrier Noise Emission Regulations (Motor Carrier Regulations)<sup>91</sup>/Interstate Motor Carrier Noise Emission Compliance Regulations (Motor Carrier Compliance Regulations);<sup>92</sup> Transportation Equipment Noise Emission Controls (these are really two regulations: Transportation Equipment Regulations<sup>93</sup>

86. In spite of the tension between federal preemption and environmental protection, Senator John V. Tunney felt that the two were not mutually exclusive:

Second, the House has accepted the Senate proposal which authorizes the Environmental Protection Agency to establish regulations for control of noise from interstate carriers, including railroads, trucks, and buses. The purpose of the amendment is to reduce the impact of conflicting State and local noise controls on interstate carriers.

I would stress, Mr. President, that the preemption provided in these sections only occurs in areas of regulation where adequate Federal regulations are in effect. And, equally important, Mr. President, is that Federal regulations must be stringent enough to meet the varying local conditions affected by interstate carriers. Not only must the Administrator establish regulations which protect public health and welfare from noise from these interstate carriers in the average situation but he must also design his regulations so that the public health and welfare is protected regardless of the location in which the interstate carrier is operating.

118 CONG. REC. 37,318 (1972).

87. 42 U.S.C. § 4917(a)(1) (1976).

88. *Id.* § 4905(c)(1).

89. See note 29 *supra*.

90. Interstate motor carriers "engaged in interstate commerce" are subject to regulation. 42 U.S.C. § 4917(a)(1) (1976).

91. The Motor Carrier Regulations are discussed at notes 99-134 and accompanying text *infra*.

92. The Motor Carrier Compliance Regulations are discussed at notes 135-213 and accompanying text *infra*.

93. That portion of the Transportation Equipment Noise Emission Controls desig-

and New Truck Regulations<sup>94</sup>); Noise Emission Standards For New Truck-Mounted Solid Waste Compactors (New Garbage Truck Regulations);<sup>95</sup> Noise Emission Standards For Buses (New Bus Regulations);<sup>96</sup> and Noise Emission Standards For Motorcycles and Motorcycle Replacement Exhaust Systems (New Motorcycle Regulations).<sup>97</sup>

*e. Section 18: Motor Carrier and Motor Carrier Compliance Regulations.* The Motor Carrier Regulations/Motor Carrier Compliance Regulations were the first regulations issued. They are section 18 regulations and comprise a two-step approach: EPA's Office of Noise Abatement and Control (ONAC) issues Motor Carrier Regulations; the Department of Transportation's Bureau of Motor Carrier Safety (BMCS) issues Motor Carrier Compliance Regulations.<sup>98</sup>

*Motor Carrier Regulations.* Proposed Motor Carrier Regulations were issued on July 24, 1973, and were published in the *Federal Register* on July 27, 1973.<sup>99</sup> In the explanatory materials accompanying the proposed Motor Carrier Regulations, ONAC indicated that there were two problems which had to be resolved before the proposed Motor Carrier Regulations could be issued. One problem involved the definitions of "best available technology" and "cost of compliance" as used in section 18 regulations. ONAC defined "best available technology" as the "noise abatement technology available for retrofit application to motor car-

---

nated as the Transportation Equipment Regulations is discussed at notes 262-85 and accompanying text *infra*.

94. That portion of the Transportation Equipment Noise Emission Controls designated as the New Truck Regulations is discussed at notes 218-61, 286-394 and accompanying text *infra*.

95. The New Garbage Truck Regulations are discussed at notes 395-98, 415-16, 421 and accompanying text *infra*.

96. The New Bus Regulations are discussed at notes 399-402, 417, 422 and accompanying text *infra*.

97. The New Motorcycle Regulations are discussed at notes 403-11, 418, 423 and accompanying text *infra*.

When these regulations were originally published, they were entitled "Motorcycle Replacement Exhaust Systems." See 43 Fed. Reg. 10,822 (1978). This title was subsequently amended to read "Motorcycles; Motorcycle Replacement Exhaust Systems." See 43 Fed. Reg. 12,047 (1978).

98. See notes 73-81 and accompanying text *supra*.

99. 38 Fed. Reg. 20,102 (1973). In developing the proposed standards ONAC considered (1) material submitted in response to its advance notice of proposed rulemaking, (2) hearings and reports prepared for EPA's report to the President and Congress on noise, (3) reviews of technical information made by staff and consultants, and (4) recommendations submitted by a task force composed of federal, state, and local government representatives. *Id.*

riers which produces meaningful reduction in the noise produced by interstate motor carriers."<sup>100</sup> Since this definition might raise questions about the term "available," ONAC defined that term to include:

1. Technology applications that have been demonstrated and can be retrofitted on existing trucks.
2. Technology for which there will be a production capacity to produce the estimated number of parts required in reasonable time to allow for distribution and installation prior to the effective date of the regulation.
3. Technology that is compatible with all safety regulations and takes into account operational considerations, including maintenance and other pollution control equipment.<sup>101</sup>

ONAC then defined "cost of compliance" as "the cost of identifying . . . the additional cost of operation and maintenance [and] . . . [t]he cost for future replacement parts."<sup>102</sup>

The other problem involved scope. Should best available technology and cost of compliance be applied to all interstate motor carriers or only to the noisiest interstate motor carriers? The "noisiest" approach would produce more immediate results<sup>103</sup> but would focus attention on mufflers.<sup>104</sup> The "all" approach might galvanize motor vehicle noise technology<sup>105</sup> but also might impede immediate results.<sup>106</sup> After considerable debate, ONAC decided to adopt the "noisiest" approach and to regulate only vehicles with a gross vehicle weight rating or a gross combination weight rating over 10,000 pounds.<sup>107</sup>

Final Motor Carrier Regulations were issued on October 21, 1974, and were published in the *Federal Register* on October 29,

100. *Id.* at 20,103.

101. *Id.*

102. *Id.*

103. "Heavy duty diesel trucks . . . are the predominant source of highway noise." *Id.* If noise abatement efforts were focused on this source, more immediate results would be achieved.

104. Muffler technology is highly developed and will bring about the single greatest reduction in the noise level created by heavy-duty diesel trucks.

105. Since a truck's component parts, unlike an automobile's component parts, are not standardized, truck noise varies considerably from vehicle to vehicle, and measures which may be effective in one case may be ineffective in another case. Quieting all motor carriers, therefore, requires attention to all the sources of noise. The language of 42 U.S.C. § 4917 (1976) tends to support the "all" approach.

106. Adoption of the "all" approach requires the Administrator to coordinate technologies at widely different stages of development. For example, muffler technology is highly developed whereas tire technology will require years of research to develop.

107. 39 Fed. Reg. 20,106 (1974).



1974.<sup>108</sup> *A Background Document for Interstate Motor Carrier Noise Emission Regulations* was published in conjunction with the final Motor Carrier Regulations and summarizes the information on which they are based.<sup>109</sup>

The final Motor Carrier Regulations are divided into two subparts.<sup>110</sup> Subpart A contains "General Provisions." Section 202.12 states that the Motor Carrier Regulations apply to (1) "all motor carriers"<sup>111</sup> engaged in interstate commerce";<sup>112</sup> (2) "motor

---

108. *Id.* at 38,208 (codified in 40 C.F.R. §§ 202.10-23 (1978)). When the proposed Motor Carrier Regulations were published on July 27, 1973, ONAC had indicated that final Motor Carrier Regulations would be published within 90 days. 38 Fed. Reg. 20,102 (1973). ONAC also indicated that the effective date of the final Motor Carrier Regulations, subject to consultation with the Secretary of Transportation, would be Oct. 1, 1974. *Id.* at 20,103. These deadlines could not be met. On Mar. 12, 1974, ONAC announced that final Motor Carrier Regulations "will be promulgated in the near future" and invited all interested parties to attend a public hearing on Mar. 20-21, 1974, where "the adequacy of the available technology requirements in the proposed standards" and the "impact of Federal preemption of State and local noise regulations by the Federal standards" were to be considered. 39 Fed. Reg. 9550 (1974).

109. U.S. ENVIRONMENTAL PROTECTION AGENCY, DOC. NO. 550/9-74-017, BACKGROUND DOCUMENT FOR INTERSTATE MOTOR CARRIER NOISE EMISSION REGULATIONS (1974). This document is divided into five sections and an appendix. Section 1 outlines ONAC's strategy to control noise from vehicles over 10,000 lbs. operated by interstate motor carriers. Section 2 discusses the technology and cost to quiet in-use vehicles. Section 5 analyzes the economic and environmental impact of the Motor Carrier Regulations. Section 4 summarizes the results of truck noise surveys. The results from truck noise surveys conducted in 13 states between 1965 and 1974 are in close agreement.

110. The proposed Motor Carrier Regulations were divided into three subparts. Subpart C of the proposed standards was entitled "Special Local Condition Determinations." 38 Fed. Reg. 20,107 (1973). Subpart C recognized that special local conditions exist and that state or local governments ought to be able to request the authority to establish and enforce ambient noise levels or to control the use, operation, or movement of motor vehicles operated by interstate motor carriers in a manner which is not identical to the Motor Carrier Regulations. Such a request was to take the form of a report. This report was to describe special local conditions, the conflict, if any, between the Motor Carrier Regulations and proposed action by the state or local government, and the interference, if any, which the proposed state or local government actions would have on interstate commerce. Subpart C was deleted from the final Motor Carrier Regulations. ONAC indicated that the material which had been found in subpt. C would be issued as "procedures" within 120 days of the publication of the final Motor Carrier Regulations. 39 Fed. Reg. 38,212, 38,208 (1974). See notes 132-34 and accompanying text *infra*.

111. A "motor carrier" is "a common carrier by motor vehicle, a contract carrier by motor vehicle, or a private carrier of property by motor vehicle as . . . defined by . . . section 203(a) of the Interstate Commerce Act [49 U.S.C. § 303(a)]." 40 C.F.R. § 202.10(1) (1978). See note 71 *supra*.

112. "Interstate commerce" is "commerce between any place in a State and any place in another State or between places in the same State through another State, whether such commerce moves wholly by motor vehicle or partly by motor vehicle and partly by rail, express, water or air . . ." 40 C.F.R. § 202.10(k) (1978).

Section 202.10(k) specifically provides that its definition of interstate commerce and the definition in the Interstate Commerce Act are the same for purposes of these regula-

vehicles<sup>113</sup> of such motor carriers which have a gross vehicle weight rating [GVWR]<sup>114</sup> or gross combination weight rating [GCWR]<sup>115</sup> in excess of 10,000 pounds"; and (3) "the total sound produced by such motor vehicles when operating under [the] conditions [specified in subpart B], including the sound produced by auxiliary equipment mounted on such motor vehicles."<sup>116</sup> The Motor Carrier Regulations do not apply to auxiliary equipment "which is normally operated only when the transporting vehicle is stationary or is moving at a speed of 5 miles per hour or less"<sup>117</sup> or to warning devices and emergency equipment.<sup>118</sup>

Subpart B contains "Operations Standards."<sup>119</sup> Sections 202.20 and 202.21 establish noise emission standards. The applicable noise emission standard depends on whether a highway or stationary test is being conducted. Table II-1<sup>120</sup> shows the noise emission standards prescribed by these tests.

tions. *Id.* However, ONAC did not adopt the exemption in the Interstate Commerce Act for motor carriers being operated within the commercial zone of an interstate metropolitan area. *Id.*

113. A "motor vehicle" is "any vehicle, machine, tractor, trailer, or semi-trailer propelled or drawn by mechanical power and used upon the highways in the transportation of passengers or property, or any combination thereof, but does not include any vehicle, locomotive, or car operated exclusively on rail or rails." *Id.* § 202.10(m).

114. "GVWR" is "the value specified by the manufacturer as the loaded weight of a single vehicle." *Id.* § 202.10(h).

115. "GCWR" is "the value specified by the manufacturer as the loaded weight of a combination vehicle." *Id.* § 202.10(i).

GCWR was not defined in the proposed Motor Carrier Regulations but has been defined in the final Motor Carrier Regulations because there was some confusion whether combination trucks, *i.e.*, tractor-trailer rigs, were covered by the proposed standards.

116. *Id.* § 202.12(a)-(c). Although both the proposed and the final Motor Carrier Regulations apply primarily to heavy-duty diesel trucks, gasoline-powered trucks and interstate buses are also subject to regulations. 38 Fed. Reg. 20,103 (1973). Heavy-duty diesel trucks are the "predominant source of highway noise." *Id.* They are 5 dB(A) noisier than gasoline-powered trucks and 12-18 dB(A) noisier than automobiles. Gasoline-powered trucks will be subject to more stringent regulation in the future. More stringent regulation is justified because gasoline-powered trucks are less noisy than heavy-duty diesel trucks. Interstate buses may be subject to further regulation. However, such regulation may not be necessary because bus noise and truck noise are reduced by similar methods. *Id.*

117. *Id.* § 202.12(d). Section 202.12(d) lists the following auxiliary equipment as examples of exempt equipment: cranes, asphalt spreaders, ditch diggers, liquid or slurry pumps, air compressors, welders, and trash compactors.

118. *See id.* § 202.12(e). Warning devices include horns and sirens. Emergency equipment includes fire engines, ambulances, police vans, rescue vans, and snowplows. Fire engines, ambulances, police vans, and rescue vans are exempt "when responding to emergency calls." *Id.* Snowplows are exempt "when in operation." *Id.*

119. Subpart B went into effect on Oct. 15, 1975. *See id.* § 202.11. The Motor Carrier Regulations did not become effective until one year after publication "in order to permit the development and application of the requisite technology." 39 Fed. Reg. 38,208 (1974).

120. Table II-1 is based on the noise emission standards described in 40 C.F.R. §§ 202.20 (highway test), .21 (stationary test) (1978).

ment to the Motor Carrier Regulations since that time.

*Motor Carrier Compliance Regulations.* Proposed Motor Carrier Compliance Regulations were issued by BMCS on February 20, 1975.<sup>135</sup> In the explanatory materials accompanying the proposed Motor Carrier Compliance Regulations, BMCS emphasized its lack of statutory authority either to alter or amend ONAC's Motor Carrier Regulations or to decline to issue the Motor Carrier Compliance Regulations. The stated reason for this emphasis was to inform regulatees that BMCS did not propose to reopen questions of best available technology, cost, federal preemption, and applicability for further consideration.<sup>136</sup> Implicit in this reason, however, is the possibility that BMCS was not completely satisfied with ONAC's Motor Carrier Regulations. BMCS was not empowered to change the Motor Carrier Regulations but could signal ONAC and the regulatees of its reservations by emphasizing its lack of authority.

BMCS also used the explanatory materials to outline the measurement procedures and enforcement techniques being proposed. The Society of Automotive Engineers (SAE) had been active for some time in developing measurement procedures.<sup>137</sup> The SAE Recommended Practice J366a, a measurement procedure for heavy trucks and buses, was a product of these efforts. In April 1973 SAE Standard J366b replaced SAE Recommended Practice J366a.<sup>138</sup>

At the time BMCS was developing the proposed Motor Carrier Compliance Regulations, several states<sup>139</sup> and cities<sup>140</sup> were already measuring noise emissions, using either SAE Standard J366b or its predecessor. SAE Standard J366b is well known and well accepted.<sup>141</sup> This measurement procedure, however, has serious environmental limitations. SAE Standard J366b emphasizes engine noise and deemphasizes tire noise.<sup>142</sup> SAE Standard J366b

135. 40 Fed. Reg. 8658 (1975).

136. *Id.*

137. For a description of the Society of Automotive Engineers and its activities, see PUBLIC HEARINGS IV, *supra* note 6, at 392 (statement of William Scott, SAE).

138. SAE Standard J366b represents no significant change from SAE Recommended Practice J366a.

139. New York State was one such state.

140. New York City was one such city.

141. See, e.g., Sullivan, *Evaluation of New Methods for Measuring Noise of Heavy Trucks and Buses* in PROCEEDINGS OF THE EPA—UNIVERSITY NOISE SEMINAR 125 (1976).

142. See notes 193-95 (Motor Carrier Regulations/Motor Carrier Compliance Regulations), 310-12 (New Truck Regulations) and accompanying text *infra*.

vehicles<sup>113</sup> of such motor carriers which have a gross vehicle weight rating [GVWR]<sup>114</sup> or gross combination weight rating [GCWR]<sup>115</sup> in excess of 10,000 pounds"; and (3) "the total sound produced by such motor vehicles when operating under [the] conditions [specified in subpart B], including the sound produced by auxiliary equipment mounted on such motor vehicles."<sup>116</sup> The Motor Carrier Regulations do not apply to auxiliary equipment "which is normally operated only when the transporting vehicle is stationary or is moving at a speed of 5 miles per hour or less"<sup>117</sup> or to warning devices and emergency equipment.<sup>118</sup>

Subpart B contains "Operations Standards."<sup>119</sup> Sections 202.20 and 202.21 establish noise emission standards. The applicable noise emission standard depends on whether a highway or stationary test is being conducted. Table II-1<sup>120</sup> shows the noise emission standards prescribed by these tests.

tions. *Id.* However, ONAC did not adopt the exemption in the Interstate Commerce Act for motor carriers being operated within the commercial zone of an interstate metropolitan area. *Id.*

113. A "motor vehicle" is "any vehicle, machine, tractor, trailer, or semi-trailer propelled or drawn by mechanical power and used upon the highways in the transportation of passengers or property, or any combination thereof, but does not include any vehicle, locomotive, or car operated exclusively on rail or rails." *Id.* § 202.10(m).

114. "GVWR" is "the value specified by the manufacturer as the loaded weight of a single vehicle." *Id.* § 202.10(h).

115. "GCWR" is "the value specified by the manufacturer as the loaded weight of a combination vehicle." *Id.* § 202.10(i).

GCWR was not defined in the proposed Motor Carrier Regulations but has been defined in the final Motor Carrier Regulations because there was some confusion whether combination trucks, *i.e.*, tractor-trailer rigs, were covered by the proposed standards.

116. *Id.* § 202.12(a)-(c). Although both the proposed and the final Motor Carrier Regulations apply primarily to heavy-duty diesel trucks, gasoline-powered trucks and interstate buses are also subject to regulations. 38 Fed. Reg. 20,103 (1973). Heavy-duty diesel trucks are the "predominant source of highway noise." *Id.* They are 5 dB(A) noisier than gasoline-powered trucks and 12-18 dB(A) noisier than automobiles. Gasoline-powered trucks will be subject to more stringent regulation in the future. More stringent regulation is justified because gasoline-powered trucks are less noisy than heavy-duty diesel trucks. Interstate buses may be subject to further regulation. However, such regulation may not be necessary because bus noise and truck noise are reduced by similar methods. *Id.*

117. *Id.* § 202.12(d). Section 202.12(d) lists the following auxiliary equipment as examples of exempt equipment: cranes, asphalt spreaders, ditch diggers, liquid or slurry pumps, air compressors, welders, and trash compactors.

118. *See id.* § 202.12(e). Warning devices include horns and sirens. Emergency equipment includes fire engines, ambulances, police vans, rescue vans, and snowplows. Fire engines, ambulances, police vans, and rescue vans are exempt "when responding to emergency calls." *Id.* Snowplows are exempt "when in operation." *Id.*

119. Subpart B went into effect on Oct. 15, 1975. *See id.* § 202.11. The Motor Carrier Regulations did not become effective until one year after publication "in order to permit the development and application of the requisite technology." 39 Fed. Reg. 38,208 (1974).

120. Table II-1 is based on the noise emission standards described in 40 C.F.R. §§ 202.20 (highway test), .21 (stationary test) (1978).

TABLE II-1

Test	Noise Emission Standard (in dB(A))	
	Highway	Speed limit of 35 mph/56 kmph or less
	86	90
Stationary <sup>121</sup>		88

The permissible noise levels in Table II-1 are measured at an open site<sup>122</sup> with fast meter response<sup>123</sup> at 50 feet/15.2 meters from "the centerline of the lane of travel" in the highway test<sup>124</sup> and 50 feet/15.2 meters from the "longitudinal centerline of the vehicle, when its engine is accelerated from idle with wide open throttle to governed speed with the vehicle stationary, transmission in neutral, and clutch engaged" in the stationary test.<sup>125</sup>

Section 202.22 provides for visual inspection of the exhaust system.<sup>126</sup> No motor carrier is to operate a motor vehicle subject to the Motor Carrier Regulations unless its exhaust system is "(1) free from defects which affect sound reduction; (2) equipped with a muffler or other noise dissipative device;<sup>127</sup> and (3) not equipped with any cut-out, by-pass, or similar device."<sup>128</sup>

121. The Department of Transportation's Bureau of Motor Carrier Safety developed the stationary test for use at weighing stations or other locations where stationary safety inspections are conducted. 38 Fed. Reg. 20,104 (1973).

122. An "open site" is "an area that is essentially free of large sound-reflecting objects, such as barriers, walls, board fences, signboards, parked vehicles, bridges or buildings." 40 C.F.R. § 202.10(o) (1978). Compare *id.* (definition of "open site" in the Motor Carrier Regulations) with 49 C.F.R. §§ 325.33, .53 (1978) (definition of "open site" in the Motor Carrier Compliance Regulations).

123. "Fast meter response" is the "fast dynamic response" of a sound level meter. This "fast dynamic response" must comply with the meter dynamic characteristics set forth in ¶ 5.3 of the American National Standard Specification for Sound Level Meters (ANSI SI.4-1971). See 40 C.F.R. § 202.10(g) (1978).

124. 40 C.F.R. § 202.20 (1978).

125. *Id.* § 202.21.

126. *Id.* § 202.22.

127. A "muffler" is "a device for abating the sound of escaping gases of an internal combustion engine." *Id.* § 202.10(n).

128. *Id.* § 202.22. Cut-outs, by-passes, or similar devices are "devices which vary the exhaust system gas flow so as to discharge the exhaust gas and acoustic energy to the atmosphere without passing through the entire length of the exhaust system, including all exhaust system sound attenuation components." *Id.* § 202.10(d).

Section 202.23 provides for visual inspection of tires.<sup>129</sup> No motor carrier is to operate a motor vehicle subject to the Motor Carrier Regulations "on a tire or tires having a tread pattern which as originally manufactured, or as newly retreaded, is composed primarily [of] cavities in the tread . . . which are not vented by grooves to the tire shoulder or circumferentially to each other around the tire."<sup>130</sup> The latter prohibition is waived if the operator can show that the motor vehicle complies with the 90 dB(A) noise emission standards when operated at a speed of more than 35 mph/56 kmph.<sup>131</sup>

A notice of proposed rulemaking to amend the Motor Carrier Regulations by adding a new subpart C was issued by ONAC on November 18, 1976, and was published in the *Federal Register* on November 29, 1976.<sup>132</sup> The purpose of this proposed amendment was "to clarify the preemptive affect of section 18(c)(1) of the [Act], and to provide procedures for the implementation of the [Administrator's] authority [to waive preemption due to special local determinations found in] section 18(c)(2) of the Act."<sup>133</sup> A notice extending the period within which written comments could be made was subsequently issued by ONAC on January 6, 1977, and was published in the *Federal Register* on January 11, 1977,<sup>134</sup> but there has been no mention of the proposed amend-

---

129. *Id.* § 202.23.

130. *Id.*

131. *Id.* In making his showing of compliance, the motor carrier must operate his motor vehicle either at the posted speed limit, or, if there is no posted speed limit, at 65 mph/104 kmph. *Id.*

132. 41 Fed. Reg. 52,320 (1976).

133. *Id.* This notice of proposed rulemaking fulfilled ONAC's promise that materials found in subpt. C of the proposed Motor Carrier Regulations and deleted in the final Motor Carrier Regulations would be issued as "procedures." See note 110 *supra*. ONAC, however, did not meet the 120 day deadline it imposed on itself. The final Motor Carrier Regulations were published on Oct. 29, 1974; the notice of proposed rulemaking was not published until Nov. 29, 1976.

Under § 18(c)(1) of the NCA, all state and local noise emission standards are preempted by the Motor Carrier Regulations. Section 18(c)(2), however, allows state and local governments to establish ambient noise levels and use controls. See notes 83-85 and accompanying text *supra*. The purpose of proposed subpt. C is to

(1) define the precise nature of the preemption imposed by section 18(c)(1) of the Act, so that State and local governments will know what regulations they may no longer adopt or enforce without EPA approval, (2) establish procedures for State and local governments to follow in seeking EPA approval of their adoption or enforcement of regulations where necessary, as authorized under section 18(c)(2), and (3) provide guidance as to EPA's interpretation of its authority under section 18(c)(2).

41 Fed. Reg. 52,320 (1976).

134. 42 Fed. Reg. 2330 (1977).

ment to the Motor Carrier Regulations since that time.

*Motor Carrier Compliance Regulations.* Proposed Motor Carrier Compliance Regulations were issued by BMCS on February 20, 1975.<sup>135</sup> In the explanatory materials accompanying the proposed Motor Carrier Compliance Regulations, BMCS emphasized its lack of statutory authority either to alter or amend ONAC's Motor Carrier Regulations or to decline to issue the Motor Carrier Compliance Regulations. The stated reason for this emphasis was to inform regulatees that BMCS did not propose to reopen questions of best available technology, cost, federal preemption, and applicability for further consideration.<sup>136</sup> Implicit in this reason, however, is the possibility that BMCS was not completely satisfied with ONAC's Motor Carrier Regulations. BMCS was not empowered to change the Motor Carrier Regulations but could signal ONAC and the regulatees of its reservations by emphasizing its lack of authority.

BMCS also used the explanatory materials to outline the measurement procedures and enforcement techniques being proposed. The Society of Automotive Engineers (SAE) had been active for some time in developing measurement procedures.<sup>137</sup> The SAE Recommended Practice J366a, a measurement procedure for heavy trucks and buses, was a product of these efforts. In April 1973 SAE Standard J366b replaced SAE Recommended Practice J366a.<sup>138</sup>

At the time BMCS was developing the proposed Motor Carrier Compliance Regulations, several states<sup>139</sup> and cities<sup>140</sup> were already measuring noise emissions, using either SAE Standard J366b or its predecessor. SAE Standard J366b is well known and well accepted.<sup>141</sup> This measurement procedure, however, has serious environmental limitations. SAE Standard J366b emphasizes engine noise and deemphasizes tire noise.<sup>142</sup> SAE Standard J366b

135. 40 Fed. Reg. 8658 (1975).

136. *Id.*

137. For a description of the Society of Automotive Engineers and its activities, see PUBLIC HEARINGS IV, *supra* note 6, at 392 (statement of William Scott, SAE).

138. SAE Standard J366b represents no significant change from SAE Recommended Practice J366a.

139. New York State was one such state.

140. New York City was one such city.

141. See, e.g., Sullivan, *Evaluation of New Methods for Measuring Noise of Heavy Trucks and Buses* in PROCEEDINGS OF THE EPA—UNIVERSITY NOISE SEMINAR 125 (1976).

142. See notes 193-95 (Motor Carrier Regulations/Motor Carrier Compliance Regulations), 310-12 (New Truck Regulations) and accompanying text *infra*.

requires a relatively large open site in which to conduct the test.<sup>143</sup> Measurements are made at 50 feet/15.2 meters.<sup>144</sup> Tests can only be conducted under favorable weather conditions.<sup>145</sup>

BMCS was aware of these limitations—particularly the open site and measurement distance limitations—and proposed a modified SAE Standard J366b measurement procedure. The explanatory materials listed seven “notable differences” between BMCS’s proposed measurement procedures and the measurement procedures then being used by several states and cities.<sup>146</sup>

1. Measurement tolerance: The proposed measurement procedures contained no tolerance factor to adjust for sound level measurement inaccuracies.<sup>147</sup> This decision was justified since such a factor should “be applied through the mechanism of administrative policy instructions to enforcement personnel, rather than by a specified tolerance level written into the enforcement regulations.”<sup>148</sup>
2. Open site requirements: The proposed measurement procedures required an “open site” that was “an open area around both the microphone and the vehicle for a distance equivalent to the distance between the microphone and the vehicle.”<sup>149</sup> This requirement was viewed as a compromise, permitting a test site relatively free of reflecting surfaces while also recognizing the need to maximize the number of open sites available for enforce-

---

143. See notes 183, 185-86 (Motor Carrier Regulations/Motor Carrier Compliance Regulations), 303 (New Truck Regulations) and accompanying text *infra*.

144. See notes 124-25 (Motor Carrier Regulations/Motor Carrier Compliance Regulations) and accompanying text *supra*, and note 307 (New Truck Regulations) and accompanying text *infra*.

145. See notes 187, 189-92 (Motor Carrier Regulations/Motor Carrier Compliance Regulations), 304, 306 (New Truck Regulations) and accompanying text *infra*.

146. 40 Fed. Reg. 8658-60 (1975).

147. *Id.* at 8658-59. “[N]oise enforcing agencies routinely add or subtract tolerances of 1 to 2 dB to or from observed noise emission levels of motor vehicles they monitor before considering enforcement action.” *Id.* at 8658.

148. *Id.* BMCS did not reject measurement tolerances but took the position that the appropriate tolerance should be determined on a case-by-case basis. This position is more flexible but also introduces an element of uncertainty not found when using fixed measurement tolerances.

149. *Id.* at 8659. The open site proposed by BMCS differs from the open site used by the California Highway Patrol, the City of Chicago, and the New Jersey Turnpike Authority. Figure A shows the open site currently used by those three entities.



ment purposes.<sup>150</sup> 3. Distance correction factors: The proposed measurement procedures did not permit measurements to be made closer than 35 feet/10.7 meters or farther than 83 feet/25.3 meters from the interstate motor carrier.<sup>151</sup> This decision was justified on the basis that measurements made closer than 35 feet/10.7 meters were “erratic”<sup>152</sup> and that measurements made

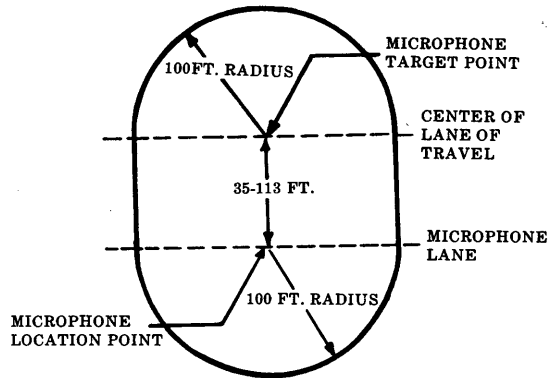

Fig. A

Figure B shows the open site proposed by BMCS.

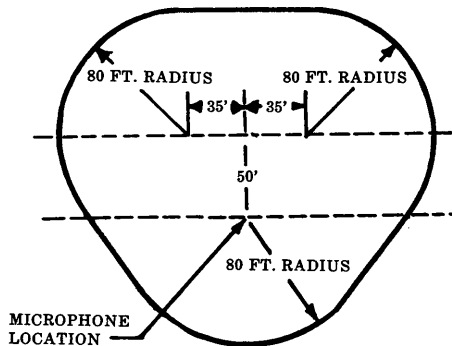

Fig. B

*Id.*

150. *Id.*

151. *Id.* “[S]everal jurisdictions . . . [allow] measurements to be made in the range from 25-35 feet.” *Id.* In addition, “California authorities . . . permit measurements to be made at distances up to 118 feet.” *Id.*

152. *Id.* BMCS elaborated on its reservations about measurements made at distances less than 35 ft./10.7 m. in the explanatory materials accompanying the final Motor Carrier Compliance Regulations:

farther than 83 feet/25.3 meters were "impractical."<sup>153</sup>

4. Ground surface correction factors: The proposed measurement procedures distinguished between "soft"<sup>154</sup> and "hard"<sup>155</sup> open sites. A 2 dB(A) correction factor would be added to measured sound levels at "soft" sites during a stationary test and would be subtracted from measured sound levels at "hard" sites during a highway test.<sup>156</sup> This distinction and the use of a correction factor was viewed as necessary to produce measurements that were "substantially" equivalent.<sup>157</sup>

5. Guard rails: The proposed measurement procedures considered a test site "adequate" even if there were guard rails within the test site.<sup>158</sup> This decision was justified on the basis that "the contribution of sound waves reflected off guard rails . . . to the overall observed sound level . . . would be negligible."<sup>159</sup> Guard rails, however, would not be permitted within the measurement area itself.<sup>160</sup>

6. Fan clutches: The proposed measurement procedures permitted the

---

Several factors cause measurements taken at distances closer than 35 feet to be viewed suspiciously. Among these are 1) near field acoustical effects not generally seen at greater measurement distances, 2) the fact that at close distances a passing truck can no longer be even approximated to be a point source of noise, thereby invalidating some theoretical source propagation models, and 3) the fact that reflection effects from the ground tend to become exaggerated at close-in measurement distances."

*Id.* at 42,434.

153. *Id.* at 8659.

154. "Soft" sites are sites where there is "a short grass cover between the highway and the microphone location point." *Id.* at 8660. The final Motor Carrier Compliance Regulations added a definition of "soft test site." Such a site is defined as "any test site having the ground surface covered with grass, other ground cover, or similar absorptive material for ½ or more of the distance between the microphone target point and the microphone location point." 49 C.F.R. § 325.5(c)(2) (1978). "Ground cover" is defined as "any of various low, dense-growing plants, such as ivy, myrtle, low weeds, or brush." *Id.* § 325.5(c)(3).

155. "Hard" sites are sites where there is "asphalt, concrete, or other acoustically 'hard' surface material between the vehicle and the microphone." 40 Fed. Reg. 8660 (1975). The final Motor Carrier Compliance Regulations added a definition of "hard test site." Such a site is defined as "any test site having the ground surface covered with concrete, asphalt, packed dirt, gravel, or similar reflective material for more than ½ the distance between the microphone target point and the microphone location point." 49 C.F.R. § 325.5(c)(1) (1978).

156. 40 Fed. Reg. 8660 (1975). BMCS contemplated that highway tests would be conducted on a "soft" site and that stationary tests would be conducted on a "hard" site. When a highway test is conducted on a hard site or a stationary test is conducted on a soft site, ground surface correction factors become necessary. *See id.*

157. *Id.*

158. *Id.*

159. *Id.* By permitting guard rails within the test site, the number of potential test sites near major highways increased dramatically. *See id.*

160. *Id.*

operator to disengage the fan clutch during the stationary test.<sup>161</sup> This provision was inserted to encourage the continued installation and use of fan clutches.<sup>162</sup>

The seventh "notable difference" is not a difference at all but a BMCS interpretation of the visual tire inspection provisions of the Motor Carrier Regulations. The Motor Carrier Regulations make the use of tires with a "cavity" tread pattern a violation unless the operator can show that the motor vehicle complies with the 90 dB(A) noise emission standard when operated at a speed of more than 35 mph/56 kmph.<sup>163</sup> These provisions raise two questions. Who has the burden of establishing the permissibility of a particular tread pattern? Where and when can an operator demonstrate compliance? Under the proposed Motor Carrier Compliance Regulations, the motor carrier had the burden of establishing that the tread pattern was of a permissible variety.<sup>164</sup> The proposed Motor Carrier Compliance Regulations also allowed BMCS to select the place and time at which the operator could demonstrate compliance with the 90 dB(A) noise emission standard.<sup>165</sup>

BMCS's proposed enforcement techniques were the same enforcement techniques being used to enforce the federal Motor Carrier Safety Regulations.<sup>166</sup> These techniques include compliance checks at roadside sites and terminal surveys.<sup>167</sup>

Final Motor Carrier Compliance Regulations were issued on September 8, 1975, and were published in the *Federal Register* on September 12, 1975.<sup>168</sup> In the explanatory materials accompanying the final Motor Carrier Compliance Regulations, BMCS summarized twenty-six different issues raised by the thirty responses filed concerning the proposed Motor Carrier Compliance Regulations and indicated the disposition of each.<sup>169</sup> The final Motor Carrier Compliance Regulations incorporated several changes based on these responses,<sup>170</sup> but none were substantial.

161. *Id.*

162. *Id.* According to BMCS "[e]xperience with fan clutches indicates that they produce salutary results in the context of truck noise abatement, and that, accordingly, their installation should be encouraged in the interests of carrying out the purpose of the Noise Control Act." *Id.*

163. See notes 130-31 and accompanying text *supra*.

164. 40 Fed. Reg. 8660 (1975).

165. *Id.*

166. *Id.* at 8660-61.

167. *Id.* at 8661.

168. 40 Fed. Reg. 42,432 (1975) (codified in 49 C.F.R. §§ 325.1-.93 (1978)).

169. 40 Fed. Reg. 42,432-36 (1975).

170. 49 C.F.R. § 325.1 (1978) (scope of the rules in this part) in subpt. A was modified.

BMCS also discussed federal preemption in the explanatory materials and took the position that "states and their political subdivisions that have not secured a special variance [are required] to apply the criteria and measurement methodologies . . . specified in Federal regulations to determine whether a motor vehicle is in conformity with noise emission standards."<sup>171</sup> This language suggests an option which does not exist. Since special variances are mentioned in the NCA<sup>172</sup> but ONAC has never adopted a variance procedure,<sup>173</sup> state and local governments have no recourse but to adopt the federal criteria and measurement methodologies.<sup>174</sup>

If state and local governments are totally preempted with respect to criteria and measurement methodologies, the prospect is not quite so bleak with respect to sanctions and corrective action, according to BMCS. The position articulated by BMCS is that state and local governments can impose sanctions and take other corrective action in accordance with their own law:

Thus, for example, a State could, if it wished, bring a civil penalty proceeding against a violator, notwithstanding the fact that, under Federal law, the violation is a crime. Similarly, a

---

*Compare* 40 Fed. Reg. 42,437 (1975) *with id.* at 8662. *See id.* at 42,433 point 1. Section 325.5 (definitions) in subpt. A was modified by adding five additional definitions. *Compare* 40 Fed. Reg. 42,437 (1975) *with id.* at 8662. Sections 325.7 (allowable noise levels) and 325.9 (measurement tolerances) were added to subpt. A. *Compare* 40 Fed. Reg. 42,437-38 (1975) *with id.* at 8662.

Sections 325.25 (calibration of measurement systems) and 325.27 (windscreens) in subpt. C were modified. *Compare* 40 Fed. Reg. 42,438 (1975) *with id.* at 8662. *See id.* at 42,433-34 points 8-10.

Sections 325.33 (site characteristics; highway operation) and 325.25 (ambient conditions; highway operations) in subpt. D were modified. *Compare* 40 Fed. Reg. 42,438-39 (1975) *with id.* at 8662-64. *See id.* at 42,434 points 11-13, 15.

Sections 325.51 (scope of rules in subpt. E), 325.54 (site characteristics; stationary test), 325.55 (ambient conditions; stationary test), and 325.59 (measurement procedure; stationary test) in subpt. E were modified. *Compare* 40 Fed. Reg. 42,439-40 (1975) *with id.* at 8664-65. *See id.* at 42,434-35 points 17, 19, 22.

Section 325.91 in subpt. G was modified. *Compare* 40 Fed. Reg. 42,441 (1975) *with id.* at 8666. *See id.* at 42,436 point 25.

171. 40 Fed. Reg. 42,435 (1975).

172. *See* note 85 and accompanying text *supra*.

173. ONAC has proposed a variance procedure. *See* note 133 and accompanying text *supra*.

174. After the proposed Motor Carrier Compliance Regulations had been issued, but before the final Motor Carrier Compliance Regulations were issued, ONAC requested that BMCS clarify which sections of the Motor Carrier Compliance Regulations would have to be incorporated by state and local governments wishing to adopt the Motor Carrier Regulations in order to comply with the preemption provisions of § 18(c)(1) of the NCA. BMCS responded that the applicable sections were subpts. C-G of the Motor Carrier Compliance Regulations. 40 Fed. Reg. 42,433 (1975).

State could, if its law permits, impound equipment found in violation of the noise emission standards, even though Federal law does not provide for impoundment as a sanction.<sup>175</sup>

The final Motor Carrier Compliance Regulations are divided into seven subparts. Subpart A contains "General Provisions." Section 325.7 establishes noise emission standards.<sup>176</sup> The applicable noise emission standard depends on the type of test and the distance between the motor carrier and the microphone making the measurement. Table II-2<sup>177</sup> shows the applicable noise emission standards prescribed by the highway and stationary tests at various distances.

TABLE II-2

Distance	Highway Test (in dB(A))				Stationary Test (in dB(A))	
	Soft Site		Hard Site		Soft Site	Hard Site
	35 mph/ 56 kmph or less	Above 35 mph/ 56 kmph	35 mph/ 60 kmph or less	Above 35 mph/ 56 kmph		
35 ft./10.7 m. or more but less than 39 ft./11.9 m.	89	93	91	95	89	91
39 ft./11.9 m. or more but less than 43 ft./14.6 m.	88	92	90	94	88	90
43 ft./13.1 m. or more but less than 48 ft./14.6 m.	88	91	89	93	87	89
48 ft./14.6 m. or more but less than 58 ft./17.1 m.	86	90	88	92	86	88
58 ft./17.1 m. or more but less than 70 ft./21.3 m.	85	89	87	91	85	87
70 ft./21.3 m. or more	84	88	86	90	84	85

Section 325.9 discusses measurement tolerances<sup>178</sup> and declares

175. 40 Fed. Reg. 42,436 (1975).

176. 49 C.F.R. § 325.7 (1978).

177. Table II-2 is based on table 1 in 49 C.F.R. § 325.7 (1978).

178. Six factors are to be considered in determining the appropriate measurement tolerance:

that “[m]easurement tolerances shall not exceed 2 decibels for a given measurement.”<sup>179</sup> Section 325.3 states that the final Motor Carrier Compliance Regulations would become effective on October 15, 1975.<sup>180</sup>

Subparts D and E contain, respectively, the measurement procedures for the highway test<sup>181</sup> and the stationary test.<sup>182</sup> Sections 325.33 and 325.53 outline the characteristics of the test site. Figure II-1<sup>183</sup> is a diagram of the test site for the highway test.

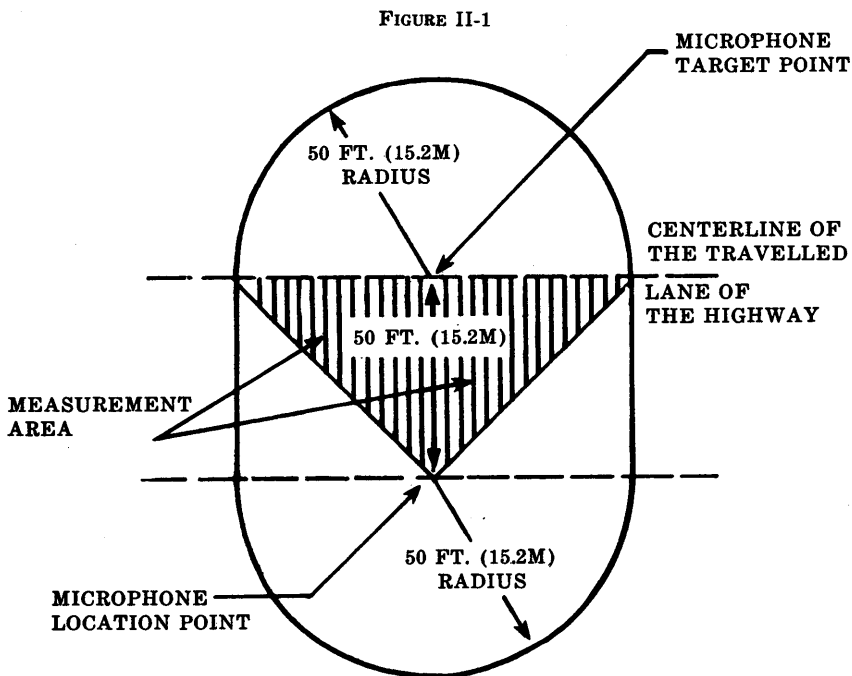

(1) The consensus standard practice of reporting filed sound level measurements to the nearest whole decibel.

(2) Variations resulting from commercial instrument tolerances.

(3) Variations resulting from the topography of the noise measurement site.

(4) Variations resulting from atmospheric conditions such as wind, ambient temperature, and atmospheric pressure.

(5) Variations resulting from reflected sound from small objects allowed within the test site.

(6) The interpretation of the effects of the above cited factors by enforcement personnel.

49 C.F.R. § 325.9(a)(1)-(6) (1978).

179. *Id.* § 325.9(b).

180. *Id.* § 325.3. The Motor Carrier Compliance Regulations thus became effective on the same day as the Motor Carrier Regulations. See note 119 *supra*.

181. 49 C.F.R. §§ 325.31-.39 (1978).

182. *Id.* §§ 325.51-.59.

183. Figure II-1 is based on fig. 1 in 49 C.F.R. § 325.33 (1978).

Figure II-2<sup>184</sup> is a diagram of the test site for the stationary test.

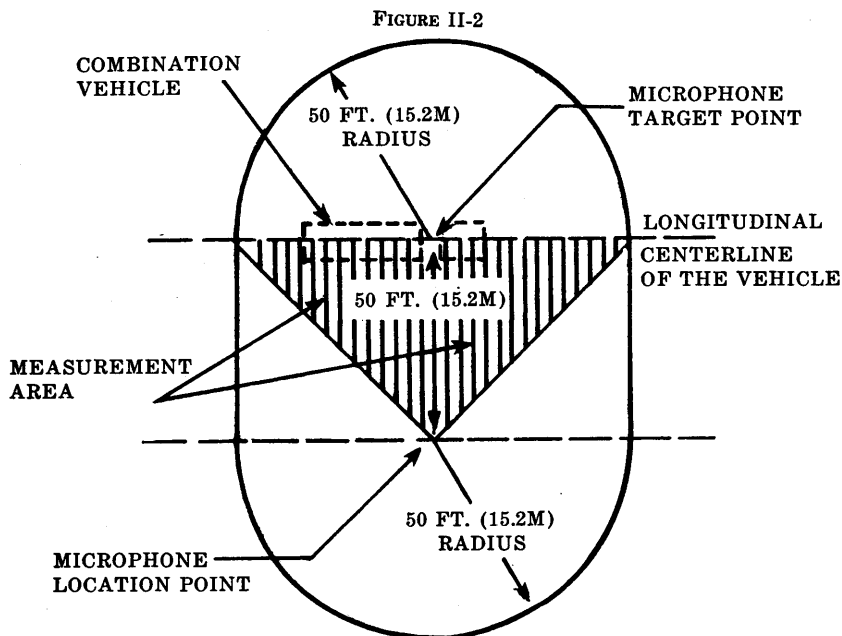

The test site must be an open site<sup>185</sup> that is “relatively flat.”<sup>186</sup> During the highway test the highway surface must be dry, paved

184. Figure II-2 is based on fig. 2 in 49 C.F.R. § 324.53 (1978).

185. The following objects can be within the test site and within the measurement area:

- (1) Small cylindrical objects such as fire hydrants or telephone or utility poles.
- (2) Rural mailboxes.
- (3) Traffic railings of any type of construction except solid concrete barriers. . . .
- (4) One or more curbs having a vertical height of 1 foot (.3 m) or less.

*Id.* §§ 325.33(b), .53(b).

The following objects can be within the test site but cannot be within the measurement area:

- (1) Any vertical surface (such as billboard) regardless of size, having a lower edge more than 15 feet (4.6 m) higher than the surface of the traveled lane of the highway.
- (2) Any uniformly smooth sloping surface slanting away from the highway (such as a rise in grade alongside the highway) with a slope that is less than 45 degrees above the horizontal.
- (3) Any surface slanting away from the highway that is 45 degrees or more and not more than 90 degrees above the horizontal, if all points on the surface are more than 15 feet (4.6 m) above the surface of the traveled lane of the highway.

*Id.* §§ 325.33(c), .53(c).

186. The Motor Carrier Compliance Regulations use “relatively flat” to describe “a noise measurement site . . . which does not contain significant concave curvatures or slope reversals that may result in the focusing of sound waves toward the microphone location point.” *Id.* § 325.5(c)(5).

with relatively smooth concrete or asphalt, and substantially free of holes or other defects and loose materials.<sup>187</sup>

Sections 325.35 and 325.55 discuss ambient noise levels. Noise measurements can only be made if the ambient noise level is 10 dB(A) or more below the permissible noise levels in Table II-2.<sup>188</sup> In addition, noise measurements can only be made if the measured wind velocity is 12 mph/19 kmph or less.<sup>189</sup> Wind gusts up to 20 mph/33 kmph, however, are allowed.<sup>190</sup> Noise measurements may be made with snow on the ground,<sup>191</sup> but noise measurements are prohibited under "any condition of precipitation" or where there is standing water on the ground surface within the measurement area.<sup>192</sup>

Sections 325.39 and 325.59 outline the measurement procedures for the highway test and stationary test. The sound level generated by the motor vehicle in the highway test is the "highest reading observed . . . as the [motor] vehicle passes through the measurement area."<sup>193</sup> Neither the grade, the load, nor whether the motor vehicle is accelerating or decelerating is to be considered in determining the sound level reading.<sup>194</sup> In order for the sound level reading to be considered valid, however, the sound level must rise at least 6 dB(A) before the maximum sound level occurs and then fall at least 6 dB(A) after the maximum sound level has occurred.<sup>195</sup>

The measurement procedure in the stationary test is more complex. The motor vehicle must be parked.<sup>196</sup> If the engine radiator fan is equipped with a clutch that either reduces the rotational speed of the fan or disengages the fan, the motor vehicle is parked with its engine running for up to ten minutes to permit the clutch to function.<sup>197</sup> All auxiliary equipment which operates

187. The highway surface must be substantially free of holes or other defects because they cause a motor vehicle to produce irregular tire, body, or chassis impact noise. *Id.* § 325.33(e)(1). "Loose materials" include but are not limited to gravel and sand. *Id.* § 325.33(e)(2).

188. *Id.* §§ 324.35(a)(2), .55(a)(2).

189. *Id.* §§ 325.35(b), .55(b). The wind velocity is measured at the beginning of each series of noise measurements and at intervals of 5-15 minutes until a constant wind velocity has been established. Thereafter, the wind velocity need only be measured at hourly intervals. *Id.*

190. *Id.*

191. *Id.* §§ 325.35(c), .55(c).

192. *Id.*

193. *Id.* § 325.39(b).

194. *Id.* § 325.39(a).

195. *Id.* § 325.39(b).

196. *Id.* § 325.59(a).

197. *Id.* § 325.59(c). The provision permitting a "cool down" period for motor vehicles



only when the motor vehicle is traveling 5 mph/8 kmph or less is turned off.<sup>198</sup> With the motor vehicle's transmission in neutral and its clutch engaged, the engine is then rapidly accelerated from idle to its maximum governed speed with wide-open throttle.<sup>199</sup> This procedure is repeated until the first two maximum sound level readings within 2 dB(A) of each other are recorded.<sup>200</sup> These two readings are numerically averaged,<sup>201</sup> and this average is the sound level generated by the motor vehicle.<sup>202</sup>

Subpart G contains the provisions on exhaust systems and tires. Section 325.91 provides that the visual exhaust system inspection requirements of the Motor Carrier Regulations<sup>203</sup> are not satisfied unless the exhaust system (1) has no defect adversely affecting sound reduction,<sup>204</sup> (2) is equipped with a muffler or other noise dissipative device,<sup>205</sup> and (3) is not equipped with a cutout, bypass, or similar device.<sup>206</sup> Section 325.93 adopts the visual tire inspection position originally taken by BMCS when the proposed Motor Carrier Compliance Regulations were issued.<sup>207</sup>

Nonsubstantive technical changes to the Motor Carrier Compliance Regulations were issued on March 4, 1976, and were published in the *Federal Register* on March 10, 1976.<sup>208</sup> One of these

---

equipped with fan clutches was controversial. Both ONAC and the Illinois Environmental Protection Agency had misgivings about this provision. See 40 Fed. Reg. 42,435 point 21 (1975). In spite of these reservations, BMCS felt "compelled" to retain the provision. *Id.*

198. 49 C.F.R. § 325.59(b) (1978). Auxiliary equipment includes "cranes, asphalt spreaders, liquid or slurry pumps, auxiliary air compressors, welders and trash compactors." *Id.*

199. *Id.* § 325.59(d).

200. *Id.* § 325.59(f).

201. *Id.*

202. *Id.* § 325.59(g).

203. See notes 126-28 and accompanying text *supra*.

204. 49 C.F.R. § 325.91(a) (1978). Defects include "exhaust gas leaks or alteration or deterioration of muffler elements." *Id.*

205. *Id.* § 325.91(b). Other dissipative devices include turbochargers. *Id.*

206. *Id.* § 325.91(c). Exhaust-gas-driven cargo-unloading systems are excepted from this prohibition. *Id.*

207. See notes 163-65 and accompanying text *supra*.

208. 41 Fed. Reg. 10,225 (1976). Most of the nonsubstantive technical changes involved subpts. D (highway test) and E (stationary test) of the Motor Carrier Compliance Regulations. Sections 325.35(a)(1) and 325.55(a)(1) were amended by adding the phrase "emanating from within the clear zone." This language was added to clarify the requirement that the ambient noise level be measured in the absence of motor vehicle noise. See 41 Fed. Reg. 10,226 point 5 (1976). As clarified by the additional language, this requirement means that ambient noise level measurement "may include any noise sources at the site, other than the noise of the vehicle within the clear zone being measured." *Id.*

Section 325.55(a)(1) was amended by deleting its concluding sentence. See note 213 *infra*. Sections 325.37(a) and 325.57(a) were amended by deleting the requirement that

changes added two new paragraphs to section 325.13.<sup>209</sup> These paragraphs establish a violation reporting procedure. BMCS personnel use form MCS-63 to record the findings of motor vehicle inspections, a copy of which is delivered to the operator of the motor vehicle.<sup>210</sup> The operator delivers or mails the form MCS-63 to the motor carrier.<sup>211</sup> Upon receipt the motor carrier is required to examine the form, take corrective action, certify on the form MCS-63 the action taken, and return the form MCS-63 to BMCS within fifteen days following the date of the inspection.<sup>212</sup> Further nonsubstantive technical changes to the Motor Carrier Compliance Regulations were issued on June 30, 1976, and were published in the *Federal Register* on July 9, 1976.<sup>213</sup>

In addition to the Motor Carrier Regulations/Motor Carrier Compliance Regulations, which are section 18 regulations, ONAC has issued four sets of section 6 regulations: the Transportation Equipment Regulations/New Truck Regulations, the New Garbage Truck Regulations, the New Bus Regulations, and the New Motorcycle Regulations. The American approach, a series of regulations for individual traffic noise sources, is fundamentally different from the German<sup>214</sup> and European Economic Community (EEC)<sup>215</sup> approach, which attempts to control all sources of traffic noise with one regulation. Since the German and EEC noise emission standards were in existence at the time the United States began to issue section 6 regulations, the American decision to adopt a series of regulations may have been based on one or both

---

the microphone be not more than 4.5 ft./1.4 m. above the surface on which the microphone stands. See 41 Fed. Reg. 10,226 point 7 (1976). "The preferred microphone height on flat terrain is 4 feet [1.2 meters]." *Id.*

Section 325.53(a)(1) was amended by adding the phrase "of the longitudinal position." See 41 Fed. Reg. 10,226 point 9 (1976). This language was added to more correctly describe the position of the microphone target point with respect to the motor vehicle's exhaust outlets in the stationary test. *Id.*

209. Paragraphs (c) and (d) were added to § 325.13. See 41 Fed. Reg. 10,226-27 (1976).

210. 49 C.F.R. § 325.13(d)(1) (1978).

211. *Id.* The driver ordinarily delivers the form MCS-63 to the motor carrier when he arrives at the next terminal or facility. If the driver is not scheduled to arrive at a terminal or facility within 24 hours after receipt of the form MCS-63, he must mail the form MCS-63 to the motor carrier. *Id.*

212. *Id.* § 325.13(d)(2)-(3).

213. 41 Fed. Reg. 28,267 (1976). At this time, BMCS acknowledged that the deletion of the concluding sentence in § 325.55(a)(1) by the earlier nonsubstantive technical changes was an inadvertent error. See note 208 *supra*. BMCS corrected that omission by adding as § 325.55(a)(2) the sentence that had been deleted. See 41 Fed. Reg. 28,267 (1976).

214. For a discussion of the German approach to noise emission standards, see Section V, notes 352-66 and accompanying text *infra*.

215. For a discussion of the approach taken by the European Economic Community to noise emission standards, see Section V, notes 366-443 and accompanying text *infra*.

of the following factors. ONAC may have had no information or, more likely, insufficient information about the German and EEC noise emission standards when the decision was made.<sup>216</sup> ONAC may also have concluded that the situation in the Federal Republic of Germany and the EEC was so different from the American situation that their experience was of limited utility to the United States.<sup>217</sup>

*f. Section 6: New Truck Regulations.* This subdivision describes and analyzes the New Truck Regulations in some detail but gives only cursory attention to the other three sets of regulations. This treatment is justified for two reasons. First, the New Truck Regulations are the only section 6 regulations to have been issued in final form. Second, the other three proposed regulations are patterned after the New Truck Regulations.

ONAC announced its plans to establish noise emission standards for new medium and heavy-duty trucks on February 22, 1974, and this announcement was published in the *Federal Register* on February 27, 1974.<sup>218</sup> In its announcement ONAC indicated that it was "gathering noise profiles, technology, cost, and other relevant data on [new medium and heavy-duty]

---

216. ONAC did publish vol. II of *An Assessment of Noise Concern in Other Nations* on Dec. 31, 1971. 2 U.S. ENVIRONMENTAL PROTECTION AGENCY, AN ASSESSMENT OF NOISE CONCERN IN OTHER NATIONS (NTID Doc. No. 300.6, 1971). This two-volume publication was nonlegal in nature and made no attempt to summarize foreign noise laws. In January 1978 ONAC published U.S. ENVIRONMENTAL PROTECTION AGENCY, FOREIGN NOISE RESEARCH IN NOISE EFFECTS (NTIS Doc. No. PB-279383/AS, 1978).

217. Based on conversations the author has had with EPA and ONAC personnel, there is no doubt that this factor contributed to the American decision to gather new information and to publish a series of regulations based on that information. EPA and ONAC personnel repeatedly emphasized the differences between the American situation and the German or EEC situation. These same personnel tended to view with disdain European noise emission standards. The author frequently heard comments to the effect that European motor vehicles were noisier than American motor vehicles. Whatever the truth of that assertion may be, the fact remains that the Germans have had noise emission standards since 1958 and the EEC has had noise emission standards since 1970. See Section V, notes 352, 366 and accompanying text *infra*. The 1970 EEC Noise Emission Directive was subsequently revised. Revision of the EEC Noise Emission Directive was being considered contemporaneously with the issuance of the New Truck Regulations by ONAC. The noise emission standard adopted by the EEC—88 dB(A) for vehicles carrying goods and having a weight exceeding 12 metric tons—is higher than the noise emission standard—83 dB(A)—adopted by ONAC in the New Truck Regulations. The 88 dB(A) level, however, represents a 3 dB(A) reduction from the 91 dB(A) adopted in the 1970 version of the EEC Noise Emission Directive. For example, compare the noise emission standards of the New Truck Regulations, note 294 and accompanying text *infra*, with the noise emission standards of the EEC Noise Emission Directive, Section V, note 441 and accompanying text *infra*.

218. 39 Fed. Reg. 7595 (1974).

trucks<sup>219</sup> and invited the public to participate in the development of noise emission standards by submitting "written data, views or arguments."<sup>220</sup>

Proposed Transportation Equipment Regulations/New Truck Regulations were issued on October 15, 1974, and were published in the *Federal Register* on October 30, 1974.<sup>221</sup> A *Background Document for Proposed Medium and Heavy Truck Noise Regulations*<sup>222</sup> was published in conjunction with the proposed New Truck Regulations and summarizes the information on which they are based.<sup>223</sup>

ONAC faced the same two problems in drafting the New Truck Regulations as had been faced in drafting the Motor Carrier Regulations. One problem involved definitions. ONAC defined "best available technology" as "that noise abatement technology available which produces the greatest achievable meaningful reduction in the noise produced by medium and heavy

---

219. *Id.*

220. *Id.* at 7595-96.

221. 39 Fed. Reg. 38,338 (1974).

222. U.S. ENVIRONMENTAL PROTECTION AGENCY, DOC. NO. 550/9-74-018, BACKGROUND DOCUMENT FOR PROPOSED MEDIUM AND HEAVY TRUCK NOISE REGULATIONS (1974). [hereinafter cited as NEW TRUCK BACKGROUND DOCUMENT].

223. The *New Truck Background Document* is divided into nine sections. Section 2 identifies medium and heavy-duty trucks as a major source of noise. See also Seybert, *Studies of Combustion and Mechanically Induced Noise in Diesel Engines*, in PROCEEDINGS OF THE EPA—UNIVERSITY NOISE SEMINAR 159 (1976). The information in § 2 is a restatement of the information found in 39 Fed. Reg. 22,297 (1974). See notes 21-23 and accompanying text *supra*. Section 3 describes trucks and the truck industry. Section 4 lists the sources on which ONAC relied in complying and analyzing the available information on truck noise: (1) studies performed by ONAC staff personnel, (2) studies performed under contract, (3) submissions by other federal agencies, (4) submissions by private parties, and (5) literature available to the public. NEW TRUCK BACKGROUND DOCUMENT, *supra* note 222, at 4-1. Section 5 analyzes the component noise levels and total truck noise levels. Section 6 explores by means of a "statistical model" and an "individual case model" the effects of truck noise on public health and welfare. The effects of truck noise on public health and welfare include "personal comfort and well-being as well as the absence of clinical symptoms (e.g., hearing loss)." *Id.* at 6-2. Section 7 uses three hypothetical models to assess the economic consequences of control and abatement. Model #1 is limited to diesel-powered trucks and postulates noise emission standards of 83 dB(a) in 1977, 80 dB(A) for the 1981 model year, and 75 dB(A) for the 1983 model year. Model #2 is limited to gasoline-powered trucks and postulates noise emission standards of 80 dB(A) in 1978 and 75 dB(A) in 1981. Model #3 covers both diesel-powered and gasoline-powered trucks, uses the model #2 time schedule, but adopts the model #1 levels for diesel-powered trucks and the model #2 levels for gasoline-powered trucks. Section 8 assesses the effect that each of these models will have on the acoustic energy generated by the future truck population. Section 8 also examines the lead time required to achieve the modifications that these models impose on truck design. Section 11 discusses the environmental effects of truck noise control.

duty trucks."<sup>224</sup> Since this definition might raise questions about "available technology," ONAC defined that term to include:

(1) technology applications that have been demonstrated to be feasible, as a prototype product upon which production manufacturing may be based;

(2) technology for which there will be a production capacity to produce the estimated number of parts required in reasonable time to allow for production installation on, or manufacture of new products prior to the effective date of the regulation; and

(3) technology that is compatible with all safety regulations and takes into account operational considerations, including maintenance and other pollution control equipment.<sup>225</sup>

ONAC then defined "cost of compliance" as

the cost of identifying what action must be taken to meet the specified noise emission level, the cost of taking that action, potential decrease in sales as a result of higher product cost as well as any additional cost of operation and maintenance [and] [t]he cost for future replacement parts and possible decrease in useful life of [the] vehicle . . . .<sup>226</sup>

ONAC did not define "public health and welfare." If the New Truck Regulations were section 18 regulations, this decision would not be surprising because section 18 regulations are based solely on best available technology and cost of compliance. The New Truck Regulations, however, are section 6 regulations. Section 6 regulations are based primarily on public health and welfare and only secondarily on best available technology and cost of compliance. Thus, ONAC defined the terms of secondary importance but not the term of primary importance. The significance of this decision became apparent when the final New Truck Regulations were issued.<sup>227</sup>

The other problem involved scope. How should trucks be classified? Who is a manufacturer? How should special purpose equipment be handled? What should the period of coverage be? In the explanatory materials accompanying the proposed New Truck Regulations, ONAC indicated that four different classification schemes had been considered,<sup>228</sup> but the explanatory materials listed only three classification schemes. Trucks can be div-

224. 39 Fed. Reg. 38,338 (1974).

225. *Id.*

226. *Id.*

227. See notes 258-59 and accompanying text *infra*.

228. See 39 Fed. Reg. 38,341 (1974).

ided on the basis of the type of engine, weight (*i.e.*, GVWR), or rated engine horsepower. Although ONAC maintained in the explanatory materials that each of these classification schemes was rejected in favor of a fourth classification scheme,<sup>229</sup> ONAC, in reality, chose the GVWR classification because the proposed New Truck Regulations cover all trucks whose GVWR is 10,000 pounds or more.<sup>230</sup> This weight was chosen because "there exists [at 10,000 pounds] a natural break between light and medium/heavy trucks."<sup>231</sup>

ONAC interpreted "manufacturer" to include not only "those persons traditionally considered vehicle manufacturers" but also "[those] persons engaged in application of enclosed bodies, racks, flat beds, mixer bodies, boost boxes, etc., to vehicles prior to receipt of the vehicle by the ultimate purchaser."<sup>232</sup> Obviously, this interpretation was adopted to give ONAC regulatory power over certain categories of manufacturers who otherwise would have escaped regulation because they are usually not considered truck manufacturers.

On the question of special purpose equipment,<sup>233</sup> ONAC concluded that such equipment need not meet the noise emission standards of the New Truck Regulations.<sup>234</sup> ONAC acknowledged that special purpose equipment may "emit significant levels of noise in some situations."<sup>235</sup> If regulation becomes necessary, however, ONAC would prefer to treat special purpose equipment as separate and distinct from medium and heavy-duty trucks.

ONAC decided that the New Truck Regulations would be applicable throughout the actual life of the vehicle.<sup>236</sup> This approach was adopted "[to] encourage proper maintenance, use, and repair practices by vehicle owners."<sup>237</sup>

In the explanatory materials, ONAC also discussed the im-

---

229. *Id.*

230. There is no distinction between the second classification—weight (*i.e.*, GVWR)—and the classification chosen by ONAC.

231. 39 Fed. Reg. 38,341 (1974).

232. *Id.*

233. "Such special purpose equipment include but are not limited to, construction equipment, snow plows, garbage compactors and refrigeration equipment." *Id.*

234. *Id.*

235. *Id.*

236. *See id.* at 38,341-42. ONAC has "waffled" on the appropriate period of coverage, as appears when the position taken in the proposed New Truck Regulations is compared with the position taken in the final New Truck Regulations. *See* notes 353-71 and accompanying text *infra*. Also, those two positions should be compared with the position taken in subsequent regulations. *See* notes 419-23 and accompanying text *infra*.

237. 39 Fed. Reg. 38,341 (1974).

pect of the proposed New Truck Regulations on new truck noise levels, the number of people affected by noise, and the cost of new trucks. New truck noise levels were expected to decrease by an average of 11 dB(A) by 1983.<sup>238</sup> If such a reduction were achieved, new truck noise levels in 1983 would be comparable to what automobile noise levels had been in 1974.<sup>239</sup>

The number of people affected by noise was also expected to decrease. ONAC estimated that 34.6 million people were affected by urban traffic noise and 2.7 million people were affected by freeway traffic noise.<sup>240</sup> If the New Truck Regulations were issued and enforced, 6.6 million people, or 19% of the group affected by urban traffic noise, and 0.9 million people, or 33% of the group affected by freeway traffic noise, would be removed from their respective groups by 1980.<sup>241</sup> Comparable estimates for 1990 projected that 18.7 million people, or 54% of the group affected by urban traffic noise, and 1.6 million people, or 59% of the total affected by freeway traffic noise, would be removed from their respective groups.<sup>242</sup>

While new truck noise levels and the number of people affected by noise were expected to decrease, the cost of new trucks was expected to increase. Table II-3<sup>243</sup> shows expected increases in capital costs.<sup>244</sup>

TABLE II-3

Year/noise level (in dB(A))	Cost (millions of dollars)
1977/83	34
1981/80	117
1983/75	294

Table II-4<sup>245</sup> shows expected dollar and percentage increases in retail price.

238. *Id.* at 38,342.

239. *Id.*

240. *Id.*

241. *Id.*

242. *Id.*

243. Table II-3 is based on information in 39 Fed. Reg. 38,342 (1974).

244. "Capital costs" are the costs associated with converting truck assembly lines from assembly lines that provide trucks that cannot satisfy the New Truck Regulations to assembly lines that produce trucks that satisfy them.

245. Table II-4 is based on a table that appeared in the final New Truck Regulations, updated from an earlier version. 41 Fed. Reg. at 15,544 (1976).

TABLE II-4

Type of Truck	83 dB(A)		80 dB(A)	
	\$ increase	% increase	\$ increase	% increase
Medium, gasoline	\$ 35	0.6	\$180	3.1
Heavy, gasoline	125	1.1	255	2.2
Medium, diesel	426	5.8	850	11.5
Heavy, diesel	356	1.4	589	2.3

Table II-5<sup>246</sup> shows expected increases in annual costs.<sup>247</sup>

TABLE II-5

Year	Cost (millions of dollars)
1980	26
1985	427
1990	1,183

According to ONAC, cost-benefit analyses demonstrated that the economic impact of the New Truck Regulations would be negligible or even slightly favorable.<sup>248</sup> Manufacturers, not surprisingly,

246. Table II-5 is based on information in 39 Fed. Reg. 38,342 (1974). In the explanatory materials accompanying the final New Truck Regulations, ONAC estimated that the uniform annualized cost would be \$225 million. 41 Fed. Reg. 15,544 (1976). When credit was given for the fuel savings resulting from the New Truck Regulations, the resulting "cost" is, in fact, a uniform annualized "saving" of \$523 million. *Id.*

247. "Annual costs" include "incremental depreciation, cost of capital, and operating expenses." 39 Fed. Reg. 38,342 (1974). The cost effectiveness of the New Truck Regulations, particularly below 83 dB(A), was a hotly debated subject. In the explanatory materials accompanying the final New Truck Regulations, ONAC maintained that "the cost effectiveness of these regulations is higher than indicated in public comments. The estimated uniform annualized costs of the regulation are no more than 0.26 percent of the uniform annualized revenues of the trucking industry." 41 Fed. Reg. 15,542 (1976) (footnote omitted).

248. ONAC summarized the cost benefit analyses as follows:

1. . . . [N]oise control regulations will have . . . little overall impact on most [truck manufacturing] firms.
2. The impact . . . [on] truck users . . . will be very small, since the cost . . . represents an increase of less than 1 percent in the annual cost of owning and operating a large diesel truck.
3. . . . [N]o substantial change in employment, number of operative plants, market shares, and profitability are expected.
4. . . . [N]o significant impact on muffler manufacturer operation with adequate lead time and appropriate planning. . . .



disputed this conclusion.<sup>249</sup> But surprisingly, independent sources have questioned ONAC's certainty, if not its conclusions. For example, the National Research Council concluded that "the total benefits of noise abatement have almost certainly been miscalculated, although we do not know, in general, whether they have been overstated or understated."<sup>250</sup>

After the proposed New Truck Regulations were issued but before the final New Truck Regulations were issued, public hearings were held in Arlington, Virginia, and San Francisco, California.<sup>251</sup> The discussion at these public hearings centered on three issues: the lead time required by manufacturers in order to comply with the noise emission standards, the enforcement program, and the impact of the New Truck Regulations.<sup>252</sup>

Final Transportation Equipment Regulations/New Truck Regulations were issued on March 31, 1976, and were published in the *Federal Register* on April 13, 1976.<sup>253</sup> A modified version of the original *Background Document for Medium and Heavy Truck Noise Emission Regulations* was published in conjunction with the final New Truck Regulations.<sup>254</sup> The final Transportation Equipment Regulations/New Truck Regulations incorporated a number of changes based on comments about the proposed Transportation Equipment Regulations/New Truck Regulations.<sup>255</sup> Several of the changes were substantial.<sup>256</sup>

- 
5. Some significant growth in the fan clutch market . . . .
  6. Channels of . . . truck distribution operations are not expected to change materially . . . .
  7. U.S. manufacturers will be in an improved competitive position in foreign markets that require quiet trucks . . . .
  8. . . . [N]oise regulation will [not] alter the position of imports . . . .
  9. . . . [N]o material impact on the balance of trade is anticipated . . . .

39 Fed. Reg. 38,342-43 (1974).

249. See note 252 and accompanying text *infra*.

250. NRC TRANSPORTATION STUDY, *supra* note 55, at 151. The National Research Council used two different cost-benefit analyses to examine the economic impact of transportation regulations. *Id.* at 193-201.

251. 41 Fed. Reg. 15,538 (1976).

252. *Id.*

253. 41 Fed. Reg. 15,538 (1976) (codified in 40 C.F.R. §§ 205.1-.59 (1978)).

254. U.S. ENVIRONMENTAL PROTECTION AGENCY, DOC. NO. 550/9-76-008, BACKGROUND DOCUMENT FOR MEDIUM AND HEAVY TRUCK NOISE EMISSION REGULATIONS (1976). This modified version of the *New Truck Background Document* should be distinguished from the original version. See note 222 *supra*.

255. In the explanatory materials accompanying the final New Truck Regulations, ONAC discussed all of the proposed changes to the proposed New Truck Regulations. Among the changes actually made were the following:

1. Definition of "Slow Meter Response." This definition was deleted.
2. Standards and dates. The effective dates of the 83 dB(A) noise emission stan-

In the explanatory materials accompanying the final Transportation Equipment Regulations/New Truck Regulations, ONAC stated its belief that "the standards established by this regulation represent the levels of noise emissions which can be achieved at reasonable cost by the respective effective dates through the application of the best available technology"<sup>257</sup> but acknowledged that "these noise levels are not sufficiently protective of public health and welfare."<sup>258</sup> This acknowledgement is an admission that ONAC is blurring the distinction between section 6 and section 18 noise emission standards and is creating a hybrid. Section 6 noise emission standards are based primarily on public health and welfare and only secondarily on best available technology and cost of compliance. The New Truck Regulations reverse these priorities. They are based primarily on best available technology and cost of compliance and only secondarily on public health and welfare. This reversal of priorities, however, is not a rejection of the section 6 approach in favor of the section 18 approach. Section 18 noise emission standards are based *solely* on best available technology and cost of compliance. The New Truck Regulations, then, take an intermediate or hybrid approach. They reverse the priorities of the section 6 approach, but their basis is broader than the section 18 approach because public health and welfare are considered.

The explanatory materials accompanying the final Transpor-

---

dards were postponed one year, and the 75 dB(A) noise emission standard for the post-1982 period was deleted.

3. Calibration. ONAC left to the complying parties the determination of how often calibration is necessary to ensure the validity of their test data but required annual calibration.

4. Automatic transmissions. The test procedure was changed to ensure that maximum engine noise is generated by vehicles equipped with automatic transmission.

5. Averaging the two highest data points. The measurement procedure was changed to allow two noise levels within 2 dB of each other to be used as the measured level on each side.

6. Cetane ratings and test results. A range of 42-50 in the cetane rating for the fuel used during testing of diesel engines was specified.

7. Allowing the demand-actuated fan to be disengaged during vehicle testing. Fan clutches may be disengaged during compliance testing.

8. Useful life standard. EPA deferred action on setting a useful life standard until sufficient data could be collected on which to base a standard.

9. Enforcement program. Thirteen separate modifications were made in the enforcement program.

41 Fed. Reg. 15,542-44 (1976).

256. See, e.g., notes 275-76, 283-85, 294-301, 332-33, 343-44 and accompanying text *infra*.

257. 41 Fed. Reg. 15,538 (1976).

258. *Id.*

tation Equipment Regulations/New Truck Regulations contained additional comments on the issue of preemption. According to ONAC, "non-identical State and local laws regulating the noise emission level of a Federally-regulated new product" are preempted.<sup>259</sup> Two provisions of state or local law—the noise emission standard itself and "those elements of the measurement methodology which are necessary to define the standard"—must be identical to federal law.<sup>260</sup> Other provisions of state or local law—"the list of persons subject to the regulations, methods of selecting test vehicles and sanctions"—need not be identical to federal law.<sup>261</sup>

The final Transportation Equipment Regulations/New Truck Regulations are divided into subparts A and B. Subpart A contains "General Provisions." These general provisions are the Transportation Equipment Regulations. Section 205.1 states that the Transportation Regulations apply to "all products<sup>262</sup> for which regulations have been published . . . and which are manufactured after the effective date of such regulations."<sup>263</sup> The Transportation Equipment Regulations, then, are applicable not only to the New Truck Regulations in subpart B but also to any future regulations involving transportation equipment to be issued by ONAC.<sup>264</sup>

259. *Id.*

260. *Id.* Major manufacturers had lobbied to have federal preemption reach testing procedures as well as noise emission standards. *See, e.g.,* 2 U.S. ENVIRONMENTAL PROTECTION AGENCY, PUBLIC HEARINGS ON NOISE ABATEMENT AND CONTROL 126-27 (1971) (Manufacturing and Transportation Noise) (statement of John Damian, Ford Motor Co.) [hereinafter cited as PUBLIC HEARINGS II].

261. 41 Fed. Reg. 15,538 (1976).

262. A "product" is "any transportation equipment for which regulations have been promulgated under this part and includes 'test product.'" 40 C.F.R. § 205.2(a)(27) (1978). A "test product" is "any product that is required to be tested pursuant to this part." *Id.* § 205.2(a)(28). A "new product" is "(a) a product the equitable or legal title of which has never been transferred to an ultimate purchaser, or (b) a product which is imported or offered for importation into the United States and which is manufactured after the effective date of . . . [noise emission regulations or labeling regulations] which would have been applicable to such product had it been manufactured in the United States." *Id.* § 205.2(a)(15).

263. *Id.* § 205.1.

264. ONAC has issued the following regulations:

New Truck Regulations (final)	subpt. B
New Bus Regulations (proposed)	subpt. C
New Motorcycle Regulations (proposed)	subpt. D
Motorcycle Replacement Exhaust Systems (proposed)	subpt. E
New Garbage Truck Regulations (proposed)	subpt. F

Section 205.4 outlines ONAC's "right" to inspect or monitor certain facilities.<sup>265</sup> The purpose of such activities is to determine "(1) whether required records are being properly maintained, (2) whether test products are being [properly] selected and prepared for testing. . . , (3) whether test product testing is being [properly] conducted . . . , and (4) whether products being produced . . . [satisfy the description found] in the production verification report."<sup>266</sup>

As a result of the Supreme Court's recent decision in *Marshall v. Barlow's, Inc.*,<sup>267</sup> ONAC has significantly revised its section 205.4 rights. ONAC may "request" a manufacturer<sup>268</sup> to admit<sup>269</sup> EPA enforcement officers<sup>270</sup> during operating hours<sup>271</sup> to the following facilities:

- (1) Any facility or site where any product to be distributed to commerce is manufactured, assembled, or stored;
- (2) Any facility or site where any tests conducted pursuant to this part or any procedures or activities connected with such tests are or were performed;

---

265. 43 Fed. Reg. 27,988 (1978).

266. 40 C.F.R. § 205.4(a)(1)-(4) (1978).

267. 436 U.S. 307 (1978).

268. "Manufacturers" are "any person engaged in the manufacturing or assembling of new products, or the importing of new products for resale, or who acts for and is controlled by any such person in connection with the distribution of such products." 40 C.F.R. § 205.2(a)(16) (1978). In addition to the traditional manufacturer, this definition includes "persons engaged in application of enclosed bodies, racks, flat beds, mixer bodies, [and] boost boxes . . . to vehicles prior to receipt of the vehicles by the ultimate purchaser . . ." 39 Fed. Reg. 38,341 (1974).

269. A manufacturer has a duty to admit an EPA enforcement officer to his facility or site if the enforcement officer presents a warrant authorizing entry. 40 C.F.R. § 205.4(e) (1978). This duty applies whether the facility is owned or controlled by the manufacturer or by one who acts for the manufacturer. *Id.* § 205.4(c)(3). This duty applies to foreign as well as domestic manufacturers and facilities. EPA will not attempt to make inspections if foreign law prohibits such inspections. However, "[i]t is the responsibility of the manufacturer to locate its testing and manufacturing facilities and sites in jurisdictions where this situation will not arise." *Id.*

270. The New Truck Regulations did not define "EPA Enforcement Officer." ONAC's June 28, 1978, revision does define that term. "An 'EPA Enforcement Officer' is an employee of the EPA Office of Enforcement who displays upon arrival at a facility or site the credentials identifying him as such an employee and a letter signed by the Director, Noise Enforcement Division designating him to make the inspection." 43 Fed. Reg. 27,990 (1978) (codified in 40 C.F.R. § 205.4(d)(1) (1978)).

271. "Operating hours" are times during which personnel, other than custodial personnel, are at work in the case of storage and areas and facilities. 40 C.F.R. § 205.4(d)(2) (1978). In other cases, "operating hours" are times during which either transportation equipment manufacture and assembly is in operation, or transportation equipment testing, maintenance, or production or compilation of records, or any other procedure or activity related to testing is being carried out in a facility. *Id.* § 205.4(d)(3).

- (3) Any facility or site where any test product is present;  
and  
(4) Any facility or site where records, reports, other documents or information required to be maintained or provided to the Administrator are located.<sup>272</sup>

The duties of EPA enforcement officers range from inspecting and monitoring the manufacture, assembly, selection, storage, preconditioning, testing, and maintenance of products to inspecting and making copies of any records, reports, documents, or information that the NCA requires the manufacturer to maintain or provide to the Administrator.<sup>273</sup> Those in charge of the facility are to furnish EPA enforcement officers with "reasonable assistance"<sup>274</sup> in performing their duties. The proposed New Truck Regulations contained a provision permitting the Assistant Administrator for Enforcement and General Counsel to issue and serve on any employee of the manufacturer a written request that the employee assist EPA enforcement officers during an inspection and entitling the employee to be accompanied, represented, and advised by counsel.<sup>275</sup> Both of the provisions were deleted in the final New Truck Regulations.<sup>276</sup>

If an enforcement officer is denied access to a facility or site<sup>277</sup> or is denied reasonable assistance,<sup>278</sup> and the infraction is "substantial,"<sup>279</sup> the Administrator, pursuant to section 11(d)(1)

272. *Id.* § 205.4(b)(1)-(4).

273. *Id.* § 205.4(c)(1)(i)-(iv).

274. *Id.* § 205.4(c)(1)(v). The proposed New Truck Regulations defined "reasonable assistance" in detail. "Reasonable assistance" includes

clerical, copying, interpretation and translation services, the making available, on request, of personnel of the facility being inspected during their working hours to inform the EPA Enforcement Officer of how the facility operates and to answer his questions, and the performance on request of noise emission tests on any transportation equipment which is being, has been, or will be used for testing.

39 Fed. Reg. 38,349 (1974). The final New Truck Regulations contain a simplified definition of reasonable assistance. Reasonable assistance is now defined to mean "providing timely and unobstructed access to test products or products and records required by . . . [the Transportation Equipment Regulations], and opportunity for copying such records or testing such test products." 40 C.F.R. § 205.2(a)(13) (1978). Such "reasonable assistance" is to be furnished without charge to EPA. *Id.* § 205.4(c)(2).

275. 39 Fed. Reg. 38,349 (1974). The proposed New Truck Regulations also provided that "[n]o counsel who accompanies, represents, or advises an employee compelled to appear may accompany, represent or advise any other person in the investigation." *Id.*

276. See 41 Fed. Reg. 15,544 points 5.11.3-4 (1976).

277. 40 C.F.R. § 205.4(f)(1)(i) (1978).

278. *Id.* § 205.4(f)(1)(ii).

279. *Id.* § 205.4(f)(2).

of the NCA,<sup>280</sup> can issue a cease-to-distribute order<sup>281</sup> for the particular products being manufactured at that facility.<sup>282</sup> The proposed New Truck Regulations contained a provision granting the Administrator discretionary authority on the question of a hearing prior to the issuance of the cease-to-distribute order.<sup>283</sup> No hearing was to be granted unless there was a substantial question of fact.<sup>284</sup> These provisions were replaced in the final New Truck Regulations by a provision which states that a cease-to-distribute order can only be issued after notice and opportunity for a hearing.<sup>285</sup>

Subpart B is entitled "Medium and Heavy Trucks." Its provisions are the New Truck Regulations. Section 205.50 states that the New Truck Regulations apply to "any vehicle<sup>286</sup> which has a gross vehicle weight rating (GVWR)<sup>287</sup> in excess of 10,000 pounds, which is capable of transportation of property on a highway or street<sup>288</sup> and which meets the definition of the term 'new prod-

280. 42 U.S.C. § 4910(d)(1) (1976). Section 11(d)(1) authorizes the Administrator to issue orders protecting public health and welfare.

281. For a discussion of cease-to-distribute orders in the context of the New Truck Regulations, see notes 327-28 and accompanying text *infra*.

282. 40 C.F.R. § 205.4(f) (1978).

283. 39 Fed. Reg. 38,349 (1974).

284. This negative inference is based on the following provision: "The Administrator may refuse to grant a hearing based upon his determination that the decision to issue such an order is based solely on inspection, tests or other information which invokes no substantial question of fact." *Id.*

285. See 41 Fed. Reg. 15,544 point 5.11.2 (1976).

286. A "vehicle" is "any motor vehicle, machine or tractor, which is propelled by mechanical power and capable of transportation of property on a street or highway and which has a gross vehicle weight rating in excess of 10,000 pounds and a partially or fully enclosed operator's compartment." 40 C.F.R. § 205.51(a)(29) (1978).

287. "GVWR" is "the value specified by the manufacturer as the loaded weight of a single vehicle." *Id.* § 205.51(a)(15).

288. A definition is given:

"Capable of Transportation of Property on a street or highway" means that the vehicle:

(i) Is self propelled and is capable of transporting any material or fixed apparatus, or is capable of drawing a trailer or semi-trailer;

(ii) Is capable of maintaining a maximum cruising speed of at least 25 mph over level, paved surface;

(iii) Is equipped or can readily be equipped with features customarily associated with practical street or highway use, such features including but not being limited to: a reverse gear and a differential, fifth wheel, cargo platform or cargo enclosure, and

(iv) Does not exhibit features which render its use on a street or highway impractical, or highly unlikely, such features including, but not being limited to, tracked road means, an inordinate size or features ordinarily associated with combat or tactical vehicles.

*Id.* § 205.51(a)(12).

uct<sup>289</sup> in [the NCA].<sup>290</sup> The New Truck Regulations do not apply to "highway, city, and school buses"<sup>291</sup> or to "special purpose equipment"<sup>292</sup> which may be located on or operated from vehicles.<sup>293</sup> In the case of special purpose equipment, tests performed on the test vehicle can be conducted with the special purpose equipment in nonoperating condition.

Section 205.52 establishes noise emission standards for new medium and heavy-duty trucks. This section in the final New Truck Regulations differs significantly from the same section in the proposed New Truck Regulations. Table II-6<sup>294</sup> shows the applicable emission standards as found in the final New Truck Regulations.

TABLE II-6

Effective Date	Noise Emission Standard (in dB(A))
January 1, 1978	83
January 1, 1982	80
January 1, 1985	[Reserved]

The major change between the noise emission standards in the proposed New Truck Regulations and the noise emission standards in the final New Truck Regulations is that the former contained a third-generation noise emission standard of 75 dB(A) while the latter reserves for future action a third-generation stan-

289. See note 29 *supra*.

290. 40 C.F.R. § 205.50(a) (1978). Before adopting a truck classification based on all trucks whose GVWR is greater than 10,000 lbs., ONAC considered but rejected classifications based on engine type (diesel vs. gasoline) and horsepower. See notes 228-30 and accompanying text *supra*.

291. Buses were identified as not being major sources of noise on June 19, 1974. See note 21 and accompanying text *supra*. However, they were designated as possible candidates for regulation on May 28, 1975. See notes 24-25 and accompanying text *supra*. ONAC has issued proposed New Bus Regulations. See notes 399-402, 417, 422 and accompanying text *infra*.

292. "[S]pecial purpose equipment includes, but is not limited to, construction equipment, snow plows, garbage compactors and refrigeration equipment." 40 C.F.R. § 205.50(b) (1978).

293. *Id.*

294. Table II-6 is based on information in 40 C.F.R. § 205.52(a) (1978). The New Truck Regulations establish two generations of noise emission standards and reserve for future action a third-generation standard. Some doubt has been expressed about ONAC's authority to set future noise standards. See *Recent Noise Control Legislation*, *supra* note 3, at 124 n.82. Apparently, ONAC does not share those doubts.

ard. This change was justified because of “uncertainties raised by many commentators concerning the ability of [ONAC] to adequately establish the availability of technology at reasonable cost for standards more stringent than 80 dB(A) for future years.”<sup>295</sup> Another significant change in the noise emission standards involved the effective dates of the 83 dB(A) and 80 dB(A) standards. They were January 1, 1977, and January 1, 1981, respectively, under the proposed New Truck Regulations; they are January 1, 1978, and January 1, 1982, respectively, under the final New Truck Regulations. According to ONAC, these changes were occasioned by “the unexpected delay in promulgating the [New Truck Regulations] from the time anticipated in the proposed rulemaking.”<sup>296</sup>

Section 205.52(a) of the proposed New Truck Regulations provided that

[new medium and heavy-duty trucks are to be] designed, built and equipped so that, if properly maintained, operated and repaired they [would] not, at any time during the life of the vehicle, produce sound emissions in excess of the [permissible sound] levels indicated [in Table II-6], when tested and evaluated as prescribed in [the New Truck Regulations] . . . .<sup>297</sup>

Two phrases—“if properly maintained, operated and repaired” and “at any time during the life of the vehicle”—were deleted in the final New Truck Regulations.<sup>298</sup> These deletions are an acknowledgment by ONAC that degradation does occur and that some allowance must be made for such degradation.<sup>299</sup> Accord-

295. 41 Fed. Reg. 15,543 (1976). Costs of compliance increase sharply as the noise emission standard becomes more stringent. See NRC TRANSPORTATION STUDY, *supra* note 55, at 167-76; notes 223, 245 *supra*.

296. 41 Fed. Reg. 15,543 (1976).

297. 39 Fed. Reg. 38,351 (1974). The noise emission standards in the New Truck Regulations are geared to low-speed, high-acceleration urban driving. *Id.* at 38,341.

298. Compare 39 Fed. Reg. 38,351 (1974) with 40 C.F.R. § 205.52(a) (1978).

299. No such acknowledgement or allowance appeared in the proposed New Truck Regulations. See notes 236-37 and accompanying text *supra*. ONAC's acknowledgement in the explanatory materials accompanying the final New Truck Regulations that degradation occurs was grudgingly given:

The requirement that the product be manufactured to meet the standard without degradation over a period of useful life is not presently included in the final regulation due to the lack of adequate data to determine the precise period of useful life and the amount of degradation (*if any*) that may be allowed to occur with use of the product. By amendment to these regulations, the Administrator will include a useful life requirement when appropriate data are collected. In-use compliance provisions are included to avoid or minimize degradation from initial noise emission levels.

41 Fed. Reg. 15,540 (1976) (emphasis added).



ingly, ONAC reserved section 205.52(d) for an "In-Use Standard" because "only limited data are available to reasonably determine whether and to what degree the noise from a properly maintained and repaired medium and heavy truck would degrade in time."<sup>300</sup> ONAC also reserved section 205.52(e) for "Low-Noise-Emission Products."<sup>301</sup>

Section 205.54 describes, as shown in Figure II-3, the test procedures to be followed in determining whether new medium and heavy-duty trucks conform to the permissible noise levels in Table II-6.<sup>302</sup>

FIGURE II-3

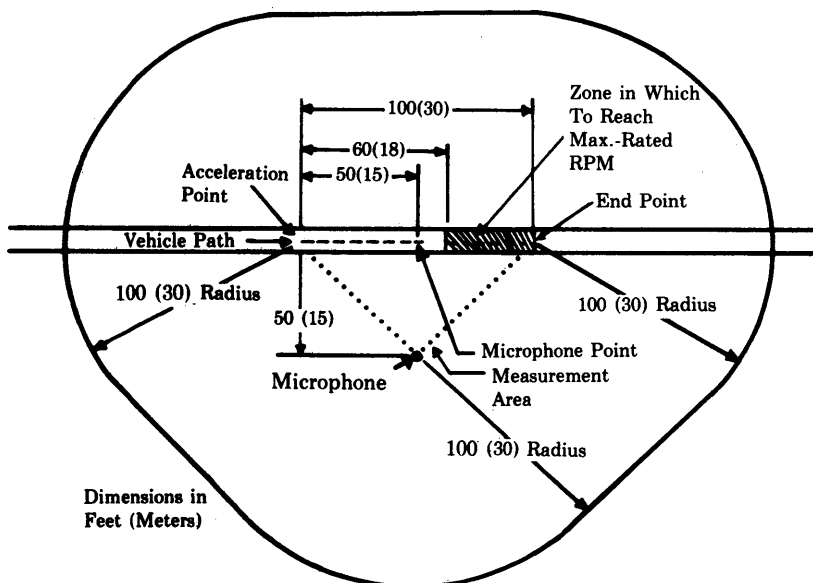

The test site must be a level open space paved with smooth concrete or smooth sealed asphalt.<sup>303</sup> During the test, the surface should be free of extraneous material such as gravel.<sup>304</sup> Noise measurements can only be made if the ambient noise level is 10 dB(A)

300. 41 Fed. Reg. 15,543 (1976).

301. *Id.* at 15,538, 15,548.

302. Figure II-3 is based on figure 204.1 in 40 C.F.R. § 205.54-1 (1978). ONAC adopted a modified SAE J366b test procedure. This test procedure was chosen because the information on which the proposed New Truck Regulations were based was measured with this procedure and because the procedure was familiar to the truck manufacturing industry. 39 Fed. Reg. 38,341 (1974). A diagram of the test site is located in 40 C.F.R. § 205.54-1 (1978) (fig. 205.1).

303. 40 C.F.R. § 205.54-1(b)(12) (1978).

304. *Id.*

or more below the permissible noise levels in Table II-6.<sup>305</sup> In addition, noise measurements can only be made if the measured wind velocity is 12 mph/19 kmph or less.<sup>306</sup> The microphone is located 50 feet/15.2 meters from the centerline of the vehicle path and 4 feet/1.2 meters above the ground.<sup>307</sup> An acceleration point and an endpoint are established. The acceleration point is 50 feet/15.2 meters before the microphone point.<sup>308</sup> The endpoint is 100 feet/30.3 meters from the acceleration point and 50 feet/15.2 meters from the microphone point.<sup>309</sup>

All new medium and heavy-duty trucks are subject to a full-throttle acceleration test. In the test the driver selects the highest rear axle and/or transmission gear and an initial vehicle speed which permits the vehicle to approach the acceleration point at no more than two-thirds of either the maximum-rated or governed engine speed.<sup>310</sup> The driver rapidly opens the throttle to wide-open at the acceleration point and continues to accelerate until maximum-rated or governed engine speed is reached.<sup>311</sup> Maximum-rated or governed engine speed must be reached within the end-zone without exceeding 35 mph/56 kmph before reaching the endpoint.<sup>312</sup>

305. *Id.* § 205.54-1(b)(11).

306. *Id.* § 205.54-1(d)(1).

307. *Id.* § 205.54-1(b)(2). In order to insure an accurate measurement, no large reflecting surfaces, such as parked vehicles, signboards, buildings, or hillsides, should be located within 100 ft./30.4 m. of either the vehicle path or the microphone. *Id.* § 205.54-1(b)(1).

308. *Id.* § 205.54-1(b)(3).

309. *Id.* § 205.54-1(b)(4).

310. *Id.* § 205.54-1(c)(1)(i) (standard transmissions), (2)(i) (automatic transmissions).

311. *Id.* § 205.54-1(c)(1)(ii) (automatic transmissions).

312. *Id.* § 205.54-1(c)(1)(i)(b)-(c) (standard transmissions), (2)(i)(b)-(c) (automatic transmissions).

ONAC's choice of 35 mph/56 kmph has been attacked because "motor vehicles today normally operate at 35 mph or above in urban areas and because tire noise usually predominates at speeds of 50 mph and over." *NCA Extension Hearings, supra* note 8, at 87 (statement of the National Organization to Insure a Sound-controlled Environment (NOISE)). NOISE proposed 50 mph/80 kmph as a substitute. *Id.*

If the maximum-rated or governed revolutions per minute (rpm) is attained before reaching the endzone, the approach rpm should be decreased in 100 rpm increments until the maximum-rated or governed rpm is attained within the endzone. 40 C.F.R. § 205.54-1(c)(1)(i)(c)(1) (1978) (standard transmissions).

If the maximum-rated or governed rpm is not attained until beyond the endzone, the next lower gear should be selected until the maximum-rated or governed rpm is attained within the endzone. *Id.* § 205.54-1(c)(1)(i)(c)(2) (standard transmissions), (2)(i)(c)(2) (automatic transmissions). Should the lowest possible gear still result in the vehicle attaining maximum-rated or governed rpm beyond the endzone, the vehicle should be unloaded and/or the approach rpm should be increased in 100 rpm increments until the

The meter used to measure the noise level should be set for "fast response" and the A-weighted network.<sup>313</sup> Readings are taken on both sides of the vehicle during acceleration or deceleration.<sup>314</sup> The applicable reading for each side is the first two pass-by measurements if they are within 2 dB(A) of each other.<sup>315</sup> If the first two pass-by measurements are not within 2 dB(A) of each other, two additional pass-by measurements are made.<sup>316</sup> The average of the two highest measurements, provided they are within 2 dB(A) of each other, is the measured vehicle sound level for that side.<sup>317</sup>

The New Truck Regulations outline a three-phase enforcement program. One phase of this enforcement program—production verification (PV)—is described in section 205.55. The purpose of PV is "to verify whether a manufacturer has the requisite noise control technology in hand and is capable of applying the technology in a manufacturing process."<sup>318</sup> The manufacturer usually conducts PV,<sup>319</sup> but the Administrator has reserved the right to conduct PV if he chooses.<sup>320</sup> PV involves six

maximum-rated or governed rpm is attained within the endzone. *Id.* § 205.54-1(c)(1)(i)(c)(3) (standard transmission), (2)(i)(c)(3) (automatic transmissions).

If the new medium or heavy-duty truck is equipped with an automatic transmission, two additional provisions may apply:

(4) Should the maximum rated or governed rpm still be attained before entering the end zone, and the engine rpm during the approach cannot be further lowered, begin acceleration at a point 10 feet closer to the beginning of the end zone. The approach rpm to be used is to be that rpm used prior to the moving of the acceleration point 10 feet closer to the beginning of the end zone.

(5) Should the maximum rated or governed rpm still be attained before entering the end zone, repeat the instructions in paragraph [4] until maximum rated or governed rpm is attained within the end zone.

*Id.* § 205.54-1(c)(2)(i)(c)(4)-(5).

313. 40 C.F.R. § 205.54-1(c)(3)(i) (1978).

314. *Id.* § 205.54-1(c)(3)(iii).

315. *Id.*

316. *Id.*

317. *Id.*

318. 41 Fed. Reg. 15,539 (1976).

319. See 40 C.F.R. § 205.55-2(a)(1) (1978). Under the New Truck Regulations, "the first person who creates the entity which conforms to the definition of vehicle is responsible for production verification and complying with the labeling requirements." 41 Fed. Reg. 15,539 (1976). This person is the manufacturer. "Any person who performs subsequent manufacturing operations on the new product after it has become a vehicle as described within these regulations need not duplicate production verification or labeling operations." *Id.* "This approach benefits the manufacturer by leaving his personnel in control of many aspects of the compliance program and imposes only a minimum burden on his business." *Id.*

320. See 40 C.F.R. § 205.56 (1978). In the proposed New Truck Regulations, PV by the Administrator did not warrant a separate section of its own, but was dealt with in

steps: identifying vehicle configurations,<sup>321</sup> selecting a vehicle,<sup>322</sup> preparing the vehicle,<sup>323</sup> testing the vehicle,<sup>324</sup> submitting a PV

---

conjunction with PV conducted by the manufacturer. *Compare* 39 Fed. Reg. 38,354-57 (1974) with 40 C.F.R. §§ 205.55-56 (1978).

If the Administrator conducts PV, he chooses the place and time for such testing. 40 C.F.R. § 205.56(a)(1) (1978). He can designate EPA's facility as the place where PV will take place. *Id.* Such a facility has been constructed at Plum Brook Station in Sandusky, Ohio. 41 Fed. Reg. 15,540 (1976). The Administrator, however, normally designates the manufacturer's test facility as the place where PV will take place. 40 C.F.R. § 205.56(a)(2) (1978). If the Administrator does make this designation, the manufacturer has the responsibility of furnishing the instrumentation and equipment specified by the New Truck Regulations. *Id.* The Administrator can also use his own equipment. If he does, the equipment must equal or exceed the performance specifications required by the New Truck Regulations. *Id.*

If the Administrator conducts PV at the manufacturer's test facility and determines that such facility is inappropriate for conducting the test, he must notify the manufacturer in writing of this fact and state the reasons for his determination. *Id.* § 205.56(b)(1). No data obtained from that facility are henceforth acceptable. *Id.* § 205.56(b)(3). The manufacturer can make a written request that the Administrator reconsider this determination. *Id.* § 205.56(b)(4). His request must be based on data or information that indicates that changes have been made in the test facility and that these changes have resolved the problems leading to the earlier disqualification. *Id.* The Administrator then has 10 days within which to study the request for requalification and to notify the manufacturer of his decision. *Id.* § 205.56(b)(5). If the Administrator chooses to do so, he may also issue a cease-to-distribute order for configurations or categories which have undergone PV at the manufacturer's test facility. *Id.* § 205.55-10(a)-(b). Such an order can only be issued after notice and an opportunity for a hearing. *Id.* The request for a hearing must be made within 15 days. *Id.* § 205.56(b)(2).

321. PV begins when the manufacturer identifies vehicle configurations. A "configuration" is "the basic classification unit of a manufacturer's product line and is comprised of all vehicle designs, models or series which are identical in material aspects with respect to [certain factors]." 40 C.F.R. § 205.51(a)(9) (1978). Each vehicle configuration undergoes PV every model year. 39 Fed. Reg. 38,343 (1974).

322. PV continues when the manufacturer selects the test vehicle. He can select "a vehicle of the subject configuration which has been assembled using [his] normal production processes and will be sold or offered for sale in commerce." 40 C.F.R. § 205.55-5(a) (1978). If the configuration to be tested consists of vehicles equipped with both standard and automatic transmissions, "the test vehicle shall be a standard transmission vehicle unless the manufacturer has reason to believe that the automatic transmission vehicle emits a greater sound level." *Id.* § 205.55-5(c). PV of this vehicle verifies all vehicles in that configuration. If a manufacturer adds a new vehicle configuration or modifies an existing vehicle configuration with respect to any of the listed factors, he must verify the new or modified vehicle configuration either by testing or by submitting a report which demonstrates verification on the basis of previously submitted data. *Id.* § 205.55-8.

Alternatively, the manufacturer can elect to group vehicle configurations into categories. If he chooses this option, separate categories are established for each combination of certain factors. *Id.* § 205.55-2(c)(1).

323. No preparation, testing, modification, adjustment, or maintenance of the vehicle thus selected is permitted unless such preparation, testing, modification, adjustment, or maintenance of the vehicle thus selected (1) is prescribed and documented in the manufacturer's internal vehicle assembly and inspection procedures, (2) is required or permitted under [the New Truck Regulations], or (3) is approved in advance by the Administrator. *Id.* § 205.55-6(a).

report,<sup>325</sup> and labeling all vehicles.<sup>326</sup>

There are two exceptions to these prohibitions. The manufacturer can install the equipment or fixtures necessary to conduct PV. *Id.* § 205.55-6(b). Such equipment or fixtures must have no effect on the noise emissions of the vehicle. *Id.* The manufacturer can also perform necessary maintenance in cases of vehicle malfunction. *Id.* § 205.55-6(c). As defined, malfunction includes such things as failure to start or a misfiring cylinder. Such maintenance must be documented and reported. *Id.*

324. The manufacturer then conducts PV for each vehicle thus selected and prepared until a valid test has been conducted. *Id.* § 205.55-7(a). In order to avoid delays caused by weather conditions which preclude testing, the New Truck Regulations provide that PV of a configuration is conditionally waived for a period of up to 90 days. *Id.* § 205.55-2(a)(2). The manufacturer must test a truck as soon as conditions permit. *Id.* § 205.55-2(a)(2)(i). Records of the conditions which make PV impossible must be kept. *Id.* § 205.55-2(a)(2)(ii). If the manufacturer has not performed PV for 45 days, the manufacturer must notify the Administrator and provide documentation of the conditions which have made PV impossible. *Id.* § 205.55-2(a)(2)(iii). The Administrator may then require "that the manufacturer ship test vehicles to the EPA test facility in order for the Administrator to perform the tests required for [PV]." *Id.* § 205.55-2(a)(3).

The manufacturer cannot substitute or replace a test vehicle unless the Administrator authorizes such substitution or replacement. *Id.* § 205.55-7(b). If a vehicle fails to comply with the applicable noise emission standard when undergoing PV, the manufacturer has two options. *Id.* § 205.55-7(c). He can delete the particular vehicle configuration from his PV report. *Id.* § 205.55-2(e)(1). A deleted configuration, however, can be included on a later PV report. *Id.* Alternatively, he can modify the vehicle and demonstrate by testing that the modified vehicle complies with the applicable noise emission standard. *Id.* § 205.55-2(e)(2). Under the proposed New Truck Regulations, a third option—treating the vehicle configuration as unverified—was mentioned. This option was deleted in the final New Truck Regulations.

325. PV continues when an authorized representative signs and submits a PV report to EPA. *Id.* § 205.55-4(b). The PV report is submitted to the Director, Noise Enforcement Division. *Id.* § 205.55-4(a).

The PV report contains the following information:

- (1) The name, location and description of the manufacturer's . . . test facilities which meet the specifications of [the New Truck Regulations] and have been utilized to conduct testing pursuant [thereto].
- (2) A description of normal predelivery maintenance procedure.
- (3) A description of all vehicle configurations . . . to be distributed in commerce . . . including a list identifying or defining any device or element of design . . . incorporated into vehicles for the purpose of noise control and attenuation . . . .
- (4) . . . [I]nformation for each noise emission test conducted . . . .
- (5) A complete description of the sound data acquisition system if other than those specified in [the New Truck Regulations].
- (6) . . . [A] statement . . . [indicating that] all testing . . . was conducted in strict conformance with [the New Truck Regulations], all . . . data . . . [is] a true and accurate representation of such testing and all other information . . . is true and accurate.

*Id.* § 205.55-4(b).

326. The manufacturer completes PV by affixing a plastic or metal label, which is permanent and legible, to each vehicle in a readily visible position in the operator's compartment. *Id.* § 205.55-11(a)(1)-(2). Labels are to be affixed so that "they cannot be removed without destroying or defacing them, and shall not be affixed to any equipment which is easily detached from such vehicle." *Id.* § 205.55-11(a)(1). In order to increase the

If the test vehicle in a particular vehicle configuration fails to successfully complete PV, the Administrator can issue a cease-to-distribute order.<sup>327</sup> Such an order will not be issued if the manufacturer has made a good faith effort to properly verify his test vehicle.<sup>328</sup> If the Administrator determines that a vehicle configuration has been distributed in commerce which does not conform to the New Truck Regulations, he can issue a recall order.<sup>329</sup> The recall order applies to all noncomplying vehicles.<sup>330</sup> Any cost associated with recalling and remedying the defects in these vehicles is borne by the manufacturer.<sup>331</sup> The New Truck Regulations provide that the Administrator shall grant a hearing prior to the issuance of a cease-to-distribute order or a recall order.<sup>332</sup> "Any such order shall be issued only after notice and an opportunity for a hearing."<sup>333</sup>

The second phase of the enforcement program—selective enforcement auditing (SEA)—is described in section 205.57. The purpose of SEA is "to determine whether production trucks conform to the standards [of the New Truck Regulations] and to provide the basis for further action in the case of nonconformity."<sup>334</sup> If the Administrator wishes to conduct testing pursuant to SEA, a test request, signed by the Assistant Administrator for

---

visibility of the information found on the label, the New Truck Regulations require that the information be printed in block letters and numerals and in a color that contrasts with the background of the label. *Id.* § 205.55-11(a)(3).

The New Truck Regulations specify the contents of the label. The label must contain (1) the following heading: "Vehicle Noise Emission Control Information," (2) the corporate name and trademark of the manufacturer, (3) date of manufacture, (4) a statement that the vehicle conforms to the applicable noise emission standard, and (5) a warning reiterating the prohibitions found in the NCA against removing or rendering inoperative any noise control device or element of design incorporated into the vehicle or using the vehicle after such device or element of design has been removed or rendered inoperative. *Id.* § 205.55-11(a)(3). Vehicles manufactured solely for use outside the United States must be clearly labeled "For Export Only." *Id.* § 205.55-11(b).

327. *Id.* § 205.55-10.

328. *Id.* § 205.55-10(a). The manufacturer has the burden of establishing good faith.

*Id.*

329. *Id.* § 205.59. The Administrator's determination that a vehicle configuration has been distributed in commerce that does not conform to the New Truck Regulations may be based on either (1) "[a] technical analysis of the noise emission characteristics of the [vehicle] configuration in question" or (2) "[a]ny other relevant information, including test data." *Id.* § 205.59(b).

330. *Id.* § 205.59(a).

331. *Id.* § 205.59(e).

332. 39 Fed. Reg. 38,356 (recall order), 38,357 (cease-to-distribute order) (1974).

333. 40 C.F.R. § 205.59(d) (1978). There is a slight difference in language. *Compare id.* § 205.55-10(b) (cease-to-distribute order) with *id.* § 205.59(d) (recall order).

334. 41 Fed. Reg. 15,539 (1976).

Enforcement or his designee and addressed to the manufacturer, is delivered by an EPA enforcement officer to the plant manager or other responsible official as designated by the manufacturer.<sup>335</sup> SEA involves five steps: selecting a batch sample,<sup>336</sup> selecting a test sample,<sup>337</sup> preparing the test sample,<sup>338</sup> testing the test sample,<sup>339</sup> and submitting an SEA report.<sup>340</sup>

---

335. 40 C.F.R. §§ 205.57-1(a)-(b) (1978). The test request specifies the vehicle configuration or category selected for testing, the batch selected for testing, the batch size, the plant or storage facility from which the vehicles will be selected, and the time at which selection will take place. *Id.* § 205.57-1(c). The test request may specify an alternative vehicle configuration or category in the event that the vehicle configuration or category selected for testing is not being manufactured at the specific plant, is not being manufactured at the specified time, or is not being stored at the specified plant or storage facility. *Id.* When the manufacturer receives the test request, his responsibility is to select and test a "batch sample" of vehicles from two consecutively produced "batches" of the specified vehicle configuration or category. *Id.* § 205.57-1(d).

336. SEA begins when the manufacturer selects a "batch sample." A "batch" is "the collection of vehicles of the same category or configuration as designated by the Administrator in a test request, from which a batch sample is to be randomly drawn, and inspected to determine conformance with the acceptability criteria." 40 C.F.R. § 205.51(a)(3) (1978). A "batch size" is "the number as designated by the Administrator in the test request of vehicles of the same category or configuration in a batch." *Id.* § 205.51(a)(4). Batch sizes range from a batch as small as four to eight vehicles to a batch as large as 25 and larger.

A "batch sample" is "the collection of vehicles of the same category, or configuration or subgroup thereof which are drawn from a batch from which test samples are drawn." *Id.* § 205.51(a)(5). The manufacturer usually selects the batch sample. *Id.* § 205.57-2(f). At their discretion, EPA enforcement officers can select the batch sample. *Id.* § 205.57-2(h). The New Truck Regulations require the manufacturer to keep the batch sample on hand until the batch is either accepted or rejected. *Id.* § 205.57-2(i).

337. SEA continues when the manufacturer selects a "test sample." A "test sample" is "the collection of vehicles from the same category or configuration or subgroup thereof which is drawn from the batch sample and which will receive noise emission tests." *Id.* § 205.51(a)(23). The test sample is selected by using the same procedure used to select the batch sample. *Id.* § 205.57-2(d). The manufacturer usually selects the test sample. *Id.* § 205.57-2(g). At their discretion, EPA enforcement officers can select the test sample. *Id.* § 205.57-2(h).

338. The preparation provisions for SEA are the preparation provisions for PV. 40 C.F.R. § 205.57-3 (1978) refers the reader to 40 C.F.R. § 205.55-6 (1978).

339. The manufacturer then conducts SEA for each vehicle thus selected and prepared until a valid test has been conducted. 40 C.F.R. § 205.57-4(a) (1978). The exceptions to maintenance during SEA are the same as the exceptions to maintenance during PV. 40 C.F.R. § 205.57-4(b) (1978) refers the reader to 40 C.F.R. § 205.57-3 (1978), which in turn refers the reader to 40 C.F.R. § 205.55-6 (1978).

If a vehicle fails to complete SEA, the manufacturer can replace the vehicle. The replacement vehicle must be a production vehicle of the same configuration as the replaced vehicle. "It will be randomly selected from the batch sample and will be subject to all the provisions of [the New Truck Regulations]." 40 C.F.R. § 205.57-4(b) (1978).

The New Truck Regulations provide that SEA testing "[be] initiated within such period as is specified within the test request." *Id.* § 205.57-1(e)(1). This period, however, may be extended in 24-hour increments if weather conditions during normal working hours do not permit testing. *Id.* In addition, the New Truck Regulations allow the manufacturer 24 hours to ship vehicles from the assembly plant to the testing facility if the testing

Acceptance or rejection of batches or batch sequences depends on the number of failing vehicles<sup>341</sup> in the batch sample or the batches.<sup>342</sup> The proposed New Truck Regulations established an acceptance quality level of 6.5%.<sup>343</sup> In the final New Truck Regulations that level has been raised to 10%.<sup>344</sup> Acceptance quality level is the "maximum percentage of failing vehicles that . . . can be considered satisfactory as a process average."<sup>345</sup> According to ONAC, "10 percent was chosen to take into account some test variability and random production errors."<sup>346</sup> One can only infer from this statement that the original figure chosen did not adequately cover those contingencies.

Under the proposed New Truck Regulations, the Administrator had two options if a batch sequence was rejected. He could choose to conduct 100% inspection.<sup>347</sup> Alternatively, he could issue a cease-to-distribute order.<sup>348</sup> The cease-to-distribute option was deleted in the final New Truck Regulations. Under the final New Truck Regulations, "the Administrator may require continued 100 percent testing with respect to all vehicles of that category or configuration produced at that plant."<sup>349</sup> Such testing

---

facility is not located at the plant or in close proximity thereto. *Id.* § 205.57-1(e)(3). The Administrator can allow more time to ship the vehicles from the assembly plant to the testing facility if the manufacturer requests additional time and his request is accompanied by a satisfactory justification. *Id.* To encourage expeditious testing, the New Truck Regulations provide that, weather permitting, a minimum of five vehicles per day be tested at each testing facility. *Id.* § 205.57-1(e)(2).

340. Within five days after the vehicles in a batch sample have been tested, the manufacturer prepares and submits an SEA report to the Administrator. *Id.* § 205.57-5(a). The SEA report includes the information required by the test request in the format stipulated in the test request and the following information:

- (1) The name, location, and description of the manufacturer's emission test facilities which meet the specifications of [the New Truck Regulations] and were utilized to conduct [SEA] testing . . . .
- (2) A description of the random vehicle selection method used . . . .
- (3) . . . [I]nformation for each noise emission test conducted . . . .
- (4) A complete description of the sound data acquisition system if other than those specified in [the New Truck Regulations].

*Id.* The SEA report also includes a statement and endorsement identical to the PV statement and endorsement. *See* note 325 *supra*.

341. A failing vehicle is one whose measured noise emissions are higher than the applicable noise emission standards. 40 C.F.R. § 205.51(a)(24) (1978).

342. *Id.* § 205.57-6(b) (batches), -7(b) (batch sequences).

343. 39 Fed. Reg. 38,358 (1974).

344. 40 C.F.R. § 205.57-2(b) (1978).

345. *Id.* § 205.51(a)(1).

346. 41 Fed. Reg. 15,539 (1976).

347. 39 Fed. Reg. 38,360 (1974).

348. *Id.*

349. 40 C.F.R. § 205.57-8(a) (1978).



continues until the manufacturer submits a written report

which identifies the reason for the noncompliance of the vehicles, describes the problem and [either] describes the proposed quality control and/or quality assurance remedies to be taken by the manufacturer . . . or [outlines] an engineering change [to be made and demonstrates that] the specified vehicle category or configuration complies with the [New Truck Regulations] by testing vehicles from two consecutively produced batches of that vehicle category or configuration in accordance with [the New Truck Regulations] and the conditions specified in the initial test request.<sup>350</sup>

No noncomplying vehicle can be distributed in commerce.<sup>351</sup> Any vehicle which demonstrates compliance may be distributed in commerce.<sup>352</sup>

Section 205.58 was entitled "useful life requirements" in the proposed New Truck Regulations but is entitled "in-use requirements" in the final New Truck Regulations.<sup>353</sup> In-use requirements are the third phase of the enforcement program. One of the in-use requirements is a noise emissions warranty.<sup>354</sup> Two copies of the warranty and two copies of all other information supplied to the ultimate purchaser<sup>355</sup> that might affect the warranty must be submitted to the Administrator<sup>356</sup> no later than the date of the

350. *Id.* § 205.57-9(a)(1)-(2).

351. *Id.* § 205.57-9(b).

352. *Id.* § 205.57-8(c).

353. Compare 39 Fed. Reg. 38,360 (1974) with 40 C.F.R. § 205.58 (1978). The change in title from "useful life requirements" to "in-use requirements" was necessary because ONAC was forced to acknowledge that degradation takes place.

354. 40 C.F.R. § 205.58-1 (1978). The noise emissions warranty contains the following language:

The manufacturer warrants to the first person who purchases this vehicle for purposes other than resale and to each subsequent purchaser that this vehicle was designed, built and equipped to conform at the time of sale to such first purchaser with all applicable U.S. EPA noise control regulations.

This warranty is not limited to any particular part, component or system of the vehicle . . . .

*Id.* § 205.58-1(a). The remainder of the second paragraph of the noise emissions warranty, as found in 41 Fed. Reg. 15,556 (1976), is incomprehensible. This problem was subsequently corrected. See note 376 *infra*.

The noise emissions warranty is a time-of-sale warranty. Claims, however, are not limited to the time of sale. They "may be made against the manufacturer at any time during the life of the vehicle with respect to a non-conformity which relates back to the date of sale." 41 Fed. Reg. 15,540 (1976).

355. The ultimate purchaser is "the first person who in good faith purchases a product for purposes other than resale." 40 C.F.R. § 205.2(a)(14) (1978).

356. The materials are actually submitted to the Director, Noise Enforcement Division.

submission of the PV report.<sup>357</sup> No later than ten days after dissemination, the manufacturer also submits two copies of any information of a general nature<sup>358</sup> that is provided to its dealers, zone representatives, or other agents regarding the administration and application of the noise emissions warranty.<sup>359</sup> The proposed New Truck Regulations contained a provision which permitted state and local governments to establish and enforce warranty provisions based on noise emission standards identical to the federal noise emission standards.<sup>360</sup> This provision was deleted in the final New Truck Regulations.

Maintenance, use, and repair instructions are a second in-use requirement. The purpose of these instructions is to inform purchasers and mechanics of the actions which are necessary to assure that degradation of noise emission levels is eliminated or minimized during the life of the vehicle.<sup>361</sup> In order to assist the purchaser in complying with the instructions, the manufacturer has the responsibility of providing a schedule of performance for all required noise emission control maintenance.<sup>362</sup> Two copies of these instructions, including the schedule of performance, are submitted to the Administrator<sup>363</sup> no later than the date of submission of the PV report.<sup>364</sup> If the instructions are unnecessary or unreasonable, the Administrator can require modification.<sup>365</sup>

The third in-use requirement mandates that each manufacturer submit to the Administrator,<sup>366</sup> on a model-year basis and for each vehicle configuration, a list of those acts that might result in an increase in noise emissions above the permissible

---

357. 40 C.F.R. § 205.58-1(b) (1978).

358. If a dealer or representative makes an inquiry with respect to a particular warranty claim, the manufacturer's response is not information of a general nature unless the information received broad dissemination. *Id.* § 205.58-1(c).

359. *Id.*

360. 39 Fed. Reg. 38,360 (1974).

361. 40 C.F.R. § 205.58-3(a)(2) (1978). The instructions should use clear, and to the extent possible, nontechnical language. *Id.* The instructions should not be used in order to secure an unfair competitive advantage. For example, "[t]hey should not restrict replacement equipment to original equipment or service to dealer service." *Id.* § 205.58-3(a)(3).

362. *Id.* § 205.58-3(b).

363. The materials are actually submitted to the Director, Noise Enforcement Division.

364. 40 C.F.R. § 205.58-3(c) (1978).

365. *Id.* § 205.58-4(d)(1).

366. The materials are actually submitted to the Director, Noise Enforcement Division.

noise levels found in Table II-6.<sup>367</sup> The Administrator uses the lists submitted by the manufacturers to develop a list of acts "which . . . constitute the removal or rendering inoperative . . . of noise control devices or elements of design of the vehicle."<sup>368</sup> This list is supplied to each manufacturer. Each manufacturer, in turn, inserts two statements about tampering in the owner's manual. One statement prohibits tampering.<sup>369</sup> The other statement lists those acts, among others, that are presumed to constitute tampering.<sup>370</sup> State and local governments are free to adopt and enforce their own prohibitions against removing or rendering inoperative noise control systems.<sup>371</sup>

Section 205.59 authorizes recall orders. The Administrator has the right to recall any vehicle for repair or modification if that vehicle does not comply with the New Truck Regulations.<sup>372</sup> Any such recall order can only be issued after notice and an opportun-

367. 40 C.F.R. § 205.58-2(a) (1978). The manufacturer is asked to indicate, wherever possible, the amount of increase in the noise level caused by these acts. *Id.*

368. *Id.* § 205.58-2(c).

369. *Id.* § 205.58-2(d)(1). This statement contains the following:

Federal law prohibits the following acts or the causing thereof: (1) The removal or rendering inoperative by any person other than for purposes of maintenance, repair, or replacement of any device or element of design incorporated into any new vehicle for the purpose of noise control prior to its sale or delivery to the ultimate purchaser or while it is in use, or (2) the use of the vehicle after such device or element of design has been removed or rendered inoperative by any person.

*Id.*

370. *Id.* § 205.58-2(d)(2).

Nonoriginal equipment aftermarket parts can be installed in or on a vehicle subject to the New Truck Regulations "if the installer has a reasonable basis for knowing that [the part] will not adversely affect noise emissions." 41 Fed. Reg. 15,541 (1976).

ONAC distinguishes between replacement and auxiliary parts:

For noise-related replacement aftermarket parts, a reasonable basis exists if (a) the installer reasonably believes that the replacement part or rebuilt part is designed to perform the same function with respect to noise control as the replaced part, or (b) the replacement part or rebuilt part is represented in writing by the part manufacturer or builder to perform the same function with respect to noise control as the replaced part. For noise-related, add-on, auxiliary, augmenting, or secondary parts or systems, a reasonable basis exists if (a) the installer knows of noise emission tests which show that the part does not cause noise emissions to exceed the time-of-sale standard; or (b) the part or system manufacturer represents in writing that tests have been performed with similar results . . . or (c) a Federal, State or local environmental control agency with appropriate jurisdiction expressly represents that a reasonable basis exists.

*Id.*

371. 40 C.F.R. § 205.58-2(f) (1978).

372. *Id.* § 205.59(a).

ity for a hearing.<sup>373</sup> The manufacturer bears all costs<sup>374</sup> associated with recall and repair or modification.<sup>375</sup>

In the two years since the final New Truck Regulations were issued, ONAC has corrected, amended, and stayed the effect of various provisions. Chronicling these changes not only is necessary but also is instructive in showing what happens to "final" regulations after issuance.

1. ONAC published a corrected version of the second paragraph of the noise emissions warranty in the *Federal Register* on April 28, 1976.<sup>376</sup>

2. Jacobs Manufacturing Co., a manufacturer of engine brakes, petitioned ONAC on June 4, 1976, to delete those provisions in the final New Truck Regulations which made trucks equipped with engine brakes subject to a closed-throttle deceleration test with the engine brake engaged. Jacobs argued that "the additional test burden would likely induce truck manufacturers to stop offering engine brakes, . . . eliminating [their] safety and economic benefits" and "there would be little environmental benefit because of [their] limited use and low noise levels."<sup>377</sup> ONAC found these arguments persuasive. An announcement deleting the engine brake provisions effective May 31, 1977,<sup>378</sup> was issued on February 23, 1977, and was published in the *Federal Register* on March 1, 1977.<sup>379</sup> ONAC took this occasion to restate its intention to issue third-generation noise emission standards for new medium and heavy-duty trucks<sup>380</sup> and cautioned that a closed-throttle deceleration test might be reinstated at that time.<sup>381</sup>

3. On June 28, 1976, several manufacturers of medium and

373. *Id.* § 205.59(d).

374. "Costs" include labor and parts. *Id.* § 205.59(e).

375. *Id.*

376. 41 Fed. Reg. 17,732 (1976). The second paragraph of the noise emissions warranty, as corrected, reads as follows:

This warranty is not limited to any particular part, component or system of the vehicle. Defects in the design, assembly, or in any part, component, or system of the vehicle which, at the time of sale to such first purchaser, caused noise emission levels to exceed Federal standards are covered by this warranty for the life of the vehicle.

*Id.*

377. 42 Fed. Reg. 11,836 (1977).

378. *Id.*

379. 42 Fed. Reg. 11,835 (1977). ONAC subsequently published a document entitled "EPA Analysis of the Amendment to Delete 'Engine Brake' Deceleration Testing From the Medium and Heavy Truck Noise Regulation." *See id.* 30,240.

380. *Id.* at 11,836.

381. *Id.*

heavy-duty trucks filed a petition for review of the New Truck Regulations in the United States Court of Appeals for the District of Columbia Circuit.<sup>382</sup> Subsequent meetings between the manufacturers and ONAC led ONAC to conclude that certain provisions in the New Truck Regulations should be amended or revoked. ONAC published a list of eighteen "proposed Miscellaneous Amendments" on May 25, 1977, and this list was published in the *Federal Register* on May 31, 1977.<sup>383</sup> No action, however, has been taken on these proposed amendments since that time.

4. The Recreation Vehicle Industry Association petitioned ONAC on October 20, 1977, to reconsider the applicability of the New Truck Regulations to motor homes. ONAC responded to the petition by staying, on November 15, 1977, the effectiveness of the New Truck Regulations with respect to motor homes, and this stay was published in the *Federal Register* on November 23,

382. *Chrysler Corp. v. EPA*, Nos. 76-1469, 76-1575, 76-1576, 76-1582 (D.C. Cir., filed June 28, 1976).

383. Some of the "proposed Miscellaneous Amendments" are quite significant:

(1) EPA proposes to consolidate the testing and pre-verification exemptions because pre-verification exemptions are a form of testing exemption.

(2) EPA proposes to amend the export exemption "so as to restrict its effect to the imposition of administrative orders . . . ."

(3) EPA proposes to amend the provisions granting exemptions so as to restrict their effect to the imposition of administrative orders.

(4) EPA proposes to amend the definitions of batch, batch sample and test sample so as to require random selection "only if the test request so specifies . . . ."

(6) EPA proposes to expand "the causes for which a manufacturer may delay [PV] while distributing products in commerce. . . ."

(7) EPA proposes minor amendments to the content of the PV Report.

(8) EPA proposes to amend the provision dealing with PV based on data for previous model years so as to provide that such PV need not be satisfied prior to the start of production.

(11) EPA proposes to amend the provisions dealing with PV conducted by the Administrator.

(12) EPA proposes to amend the SEA test request provisions so as "to set a limit on the number of test requests, . . . establish that a test request can be issued for a subgroup of a configuration," and "[extend] the reasons allowed for delaying initiation of testing to any conditions beyond the control of the manufacturer."

(14) EPA proposes to delete the test report requirements from SEA.

(15) EPA proposes to permit manufacturers to voluntarily cease distribution of categories and subgroups as well as configurations.

(16) EPA proposes to grant a hearing before 100 percent testing could be ordered.

42 Fed. Reg. 27,621-22 (1977).

1977.<sup>384</sup> The stay originally continued until February 21, 1978,<sup>385</sup> but was subsequently extended until "90 days following publication of notice in the *Federal Register*."<sup>386</sup>

5. One issue raised by the petition for review filed by the manufacturers on June 28, 1976, involved the noise emissions warranty. ONAC announced on November 23, 1977, that "an alternative warranty" could be used in place of "the existing warranty" by manufacturers of incomplete vehicles, and this announcement appeared in the *Federal Register* on November 29, 1977.<sup>387</sup> This announcement was viewed as an interim solution to the warranty issue until there was a final judicial resolution.<sup>388</sup>

6. On November 29, 1977, ONAC corrected a number of typographical and editorial errors and "clarified" certain provisions in the New Truck Regulations.<sup>389</sup> These corrections and clarifications appeared in the *Federal Register* on December 5, 1977.<sup>390</sup>

7. The Fire Apparatus Manufacturers Division of the Truck Body and Equipment Association petitioned ONAC on July 29, 1977, to reconsider the applicability of the New Truck Regulations to fire apparatus. ONAC responded to the petition on December 30, 1977, by staying the effectiveness of the New Truck Regulations with respect to fire apparatus, and this stay was published in the *Federal Register* on January 12, 1978.<sup>391</sup> The stay continues in effect until ninety days following publication of notice in the *Federal Register*.<sup>392</sup>

8. ONAC's most recent action with respect to the New Truck Regulations occurred on March 17, 1978, and was published in the *Federal Register* on March 24, 1978.<sup>393</sup> At that time,

---

384. *Id.* at 59,975.

385. *Id.*

386. *Id.* at 60,912.

387. *Id.* at 60,741.

388. *Id.*

389. One error was in a labeling compliance provision that called for date of manufacture. This provision was amended to require month and year of manufacture. *Id.* at 61,456 point 7. See also *id.* at 61,456 points 2-3, 8-10.

One clarification was a revision of the definition of "vehicle": "Vehicle means any motor vehicle, machine or tractor, which is propelled by mechanical power and capable of transportation of property on a street or highway and which has a gross vehicle weight rating in excess of 10,000 pounds and a partially or fully enclosed operator's compartment." *Id.* at 61,456 point 1. This definition should be compared with the definition in note 286 and accompanying text *supra*. See also *id.* at 61,456 points 3-6.

390. *Id.* at 61,456.

391. 43 Fed. Reg. 1796 (1978).

392. *Id.*

393. *Id.* at 12,326.

ONAC announced certain administrative and clarifying changes.<sup>394</sup>

*g. Other section 6 regulations.* In addition to the New Truck Regulations, ONAC has issued three additional section 6 regulations involving transportation equipment. Proposed New Garbage Truck Regulations were issued on August 12, 1977, and were published in the *Federal Register* on August 26, 1977.<sup>395</sup> A document entitled "Environmental Impact Statement, Economic Impact Statement and Background Document for Noise Emission Standards for Truck-Mounted Solid Waste Compactors"<sup>396</sup> was published in conjunction with the proposed New Garbage Truck Regulations and summarizes the information on which they are based.

The proposed New Garbage Truck Regulations define a garbage truck as "a truck mounted solid waste compactor, which comprises an engine-powered truck cab and chassis or trailer, equipped with machinery for receiving, compacting, transporting, and unloading solid waste."<sup>397</sup> Table II-7<sup>398</sup> shows the proposed noise emission standards for new garbage trucks.

TABLE II-7

Effective Date	Noise Emission Standard (in dB(A))
January 1, 1979	78
January 1, 1982	75

Proposed New Bus Regulations were issued on August 29, 1977, and were published in the *Federal Register* on September 12, 1977.<sup>399</sup> A document entitled "Draft Environmental Impact Statement, and Background Document for the Proposed Bus

394. These changes include:

1. All submittals are now sent to the Director, Noise Enforcement Division.
2. Test report results should be sent to the Director, Noise Enforcement Division.
3. The written authorization for inspection of a manufacturer's facility is signed by the Director, Noise Enforcement Division, or his designee.
4. The test request for SEA specifies the batch from which sampling is to begin rather than the batch selected for testing.

395. 42 Fed. Reg. 43,226 (1977).

396. See *id.* at 43,233.

397. *Id.* at 43,234 (1977).

398. Table II-7 is based on information in 42 Fed. Reg. 43,234 (1977).

399. *Id.* at 45,776.

Noise Emission Regulation"<sup>400</sup> was published in conjunction with the proposed New Bus Regulations and summarized the information on which they are based.

The proposed New Bus Regulations define a bus as "any vehicle which has an enclosed passenger compartment."<sup>401</sup> Table II-8<sup>402</sup> shows the proposed noise emission standards for new buses.

TABLE II-8

Effective Date	Noise Emission Standard (in dB(A))	
	Exterior	Interior
January 1, 1979	83	86
January 1, 1983	80	83
January 1, 1985	77	80

Proposed New Motorcycle Regulations were issued on March 1, 1978, and were published in the *Federal Register* on March 15, 1978.<sup>403</sup> Documents designated *Background Document for Proposed New Motorcycle Noise Emission Regulations*<sup>404</sup> and "Draft Environmental and Inflationary Impact Statement for Proposed New Motorcycle Noise Emission Regulations"<sup>405</sup> were published in conjunction with the proposed New Motorcycle Regulations.

The proposed New Motorcycle Regulations define a motorcycle as

any motor vehicle, other than a tractor, that: [1] [h]as two or three wheels; [2] [h]as a curb mass less than or equal to [1499 pounds/680 kilograms]; and [3] [i]s capable, with [a 176 pound/80 kilogram] driver, of achieving a maximum speed of at least [15 mph/24 kmph] over a level paved surface.<sup>406</sup>

Table II-9<sup>407</sup> shows the proposed noise emission standards for various categories of new motorcycles and for motorcycle replacement exhaust systems.

400. *See id.* at 45,783.

401. *Id.* at 45,784.

402. Table II-8 is based on information in 42 Fed. Reg. 45,784 (1977).

403. 43 Fed. Reg. 10,822 (1978).

404. U.S. ENVIRONMENTAL PROTECTION AGENCY, DOC. NO. 550/9-77-203, BACKGROUND DOCUMENT FOR PROPOSED NEW MOTORCYCLE NOISE EMISSION REGULATIONS (1977).

405. *See* 43 Fed. Reg. 10,840 (1978).

406. *Id.* at 10,841.

407. Table II-9 is based on information in 43 Fed. Reg. 10,842 (1978).



TABLE II-9

Category/Effective Date	Noise Emission Standard (in dB(A))
1. Street motorcycles <sup>408</sup>	
January 1, 1980	83
January 1, 1982	80
January 1, 1985	78
2. Moped-type street motorcycles <sup>409</sup>	
January 1, 1980	70
3. Off-road motorcycles <sup>410</sup>	
170 cc displacement or less	
January 1, 1980	83
January 1, 1982	80
January 1, 1985	78
More than 170 cc displacement	
January 1, 1980	86
January 1, 1983	82

All three sets of proposed regulations are patterned after the New Truck Regulations. All three, for example, propose to use the three-phase enforcement program of PV, SEA, and in-use requirements. There are, however, differences. One major differ-

408. A "street motorcycle" is:

(i) Any motorcycle that:

(A) With an 80 kg (176 lb) driver, is capable of achieving a maximum speed of at least 40 km/h (25 mph) over a level paved surface; and

(B) Is equipped with features customarily associated with practical street or highway use, such features including but not limited to any of the following: stoplight, horn, rear view mirror, turn signals; or

(ii) Any motorcycle that:

(A) Has a engine displacement less than 50 cubic centimeters;

(B) Produces no more than two brake horse power;

(C) With an 80 kg (176 lb) driver, cannot exceed 48 km/h (30 mph) over a level paved surface; and

(D) Is equipped with fully operative pedals for propulsion by human power.

43 Fed. Reg. 10,841 (1978).

409. A "moped-type street motorcycle" is included in subgroup (ii) of the street motorcycle definition. See note 408 *supra*.

410. An "off-road motorcycle" is "any motorcycle that is not a street motorcycle or competition motorcycle." 43 Fed. Reg. 10,841 (1978). A street motorcycle has already been defined. See note 408 *supra*. A "competition motorcycle" is "any motorcycle designed and marketed solely for use in closed course competition events." 43 Fed. Reg. 10,841 (1978).

ence is that the New Motorcycle Regulations are the first regulations to treat replacement parts separately and distinctly. This kind of treatment was probably occasioned by the realization that "much of the current impact from motorcycles comes from owner-modified motorcycles (particularly those with replacement and modified exhaust systems)."<sup>411</sup>

The other major difference between the proposed regulations and the New Truck Regulations is the introduction of several new concepts. One such concept is a Low-Noise-Emission Product (LNEP) level. Section 15 of the NCA<sup>412</sup> establishes a process by which the federal government as a purchaser can give preference to products whose noise emissions are significantly below those required by section 6 regulations. Such products are low-noise-emission products.<sup>413</sup> Ordinarily, the LNEP level is 5 dB(A) below the regulatory limit.<sup>414</sup> The LNEP of 70 dB(A) for new garbage trucks is 8 dB(A) below the regulatory level.<sup>415</sup> An LNEP level greater than 5 dB(A) was justified for new garbage trucks because "certain gasoline-powered trucks . . . already are close to meeting a 73 dB(A) level, and therefore an LNEP level of 73 dB(A) would provide no incentive for further development of technology or acoustical quality control."<sup>416</sup> Table II-10<sup>417</sup> shows the LNEP levels for new buses.

TABLE II-10

Procurement Date	LNEP Level (in dB(A))	
	Exterior	Interior
January 1, 1978	78	81
January 1, 1982	75	78
January 1, 1984	72	75

Table II-11<sup>418</sup> shows the LNEP levels for new motorcycles.

411. 43 Fed. Reg. 10,822-23 (1978).

412. 42 U.S.C. § 4914 (1976).

413. For a discussion of § 15 of the NCA and low-noise-emission products, see notes 451-93 and accompanying text *infra*.

414. See notes 484-85 and accompanying text *infra*.

415. 42 Fed. Reg. 43,234 (1977).

416. *Id.* at 43,227.

417. Table II-10 is based on a table in 42 Fed. Reg. 45,784-85 (1977).

418. Table II-11 is based on information in 43 Fed. Reg. 10,842 (1978).

TABLE II-11

Category/Procurement Date	LNEP Level (in dB(A))
1. Street motorcycles	
January 1, 1979	75
January 1, 1984	73
2. Moped-type street motorcycles	
January 1, 1979	65
3. Off-road motorcycles	
170 cc displacement or less	
January 1, 1979	70
More than 170 cc displacement	
January 1, 1979	75

An acoustical assurance period and a sound level degradation factor are the other new concepts. The acoustical assurance period is the period beginning at the date of sale to the ultimate purchaser during which the new product must meet the noise emission standards specified by the applicable regulations. ONAC considers this limitation necessary because "if the product is not built such that it is even minimally capable of meeting the standard while in use over this initial period, when properly used and maintained, then the standard itself becomes a nullity and the anticipated health and welfare benefits become illusory."<sup>419</sup> The sound level degradation factor is the amount of increase in the noise level which the manufacturer expects will occur during the acoustical assurance period. These two concepts interact as follows:

[I]f a manufacturer estimates that the noise level of his product may increase 3 dB(A) during the AAP [acoustical assurance period] the SLDF [sound level degradation factor] would be 3 dB(A). Then, for production verification . . . the manufacturer would have to establish that the sound level of his product is 3 dB(A) lower than that specified by the standard. If a product is not expected to degrade during the AAP, the SLDF would be near or equal to zero. It is EPA's evaluation that in most cases the SLDF would be near or equal to zero.<sup>420</sup>

ONAC has selected the following acoustical assurance periods: 3

419. 42 Fed. Reg. 43,229, 45,779 (1977).

420. 42 Fed. Reg. 43,230, 45,780 (1977); 43 Fed. Reg. 10,831 (1978).

years or 7500 operating hours, whichever occurs first, for new garbage trucks;<sup>421</sup> 2 years or 200,000 miles/321,800 kilometers, whichever occurs first, for new buses;<sup>422</sup> 1 year or 3730 miles/6000 kilometers, whichever occurs first, for new motorcycles; and 1 year or 3000 miles/4826 kilometers, whichever occurs first, for off-road motorcycles.<sup>423</sup>

## 2. *Product noise labels*

The Department of Commerce Panel on Noise Abatement observed in 1970 that "very few consumer products are sold today with any noise rating available, either on the product, its packaging, or at the point of sale."<sup>424</sup> Nevertheless, the Panel on Noise Abatement was convinced that "the public will demand and have the right to know the noise levels of the products they are buying."<sup>425</sup>

During the hearings that were held prior to the enactment of the NCA, a sharp difference of opinion emerged as to the need for and utility of product noise labels. Proponents viewed product noise labels as an integral part of an effective noise control program. They noted that consumers tend to equate noise with power and efficiency.<sup>426</sup> They then argued that consumers would choose quieter products, even if those products were more costly, if they were aware of the adverse effects of noise and could pick and choose among products based on the amount of noise produced. Product noise labels are the device which allows consumers to pick and choose. A systematic attack on urban noise, therefore, involves at least two steps: "First, a nationwide program of required noise labeling. . . . Second, . . . a program of consumer education. Industry-wide efforts to label the noise levels of equipment will be of little value unless the consumer is also educated into the meaning of these figures."<sup>427</sup>

---

421. 42 Fed. Reg. 43,234 (1977).

422. *Id.* at 45,784.

423. 43 Fed. Reg. 10,842 (1978).

424. DEPARTMENT OF COMMERCE, THE NOISE AROUND US, REPORT OF THE PANEL ON NOISE ABATEMENT 7 (1970).

425. *Id.*

426. See Section I, note 35 and accompanying text *supra*.

427. 3 U.S. ENVIRONMENTAL PROTECTION AGENCY, PUBLIC HEARINGS ON NOISE ABATEMENT AND CONTROL 79 (1971) (statement of Robert H. Pish, Southwest Research Institute) [hereinafter cited as PUBLIC HEARINGS III]. Attention has focused not only on the need for product noise labels but also on their content. The argument has been made that consumers cannot be educated to understand decibel measurement and that product noise levels should contain a warning of harmful effects rather than a dB(A) rating. See *Recent Noise Control Legislation*, *supra* note 3, at 130.

Opponents took a wholly different view of product noise labels. They questioned the assumption that product noise labels were in the public interest:

We feel that labeling does not serve the public's interest either as an enforcement tool or as an informative device. Labeling readily emerges as a way of demonstrating compliance, but misleads persons inspecting equipment for compliance into the belief that a label assures continued acceptable performance. We do not believe so. To insure that products are performing as required, they must be objectively inspected. We suggest that the expedient of labeling be abandoned and a meaningful inspection procedure for automotive equipment be pursued. To do less would be taking half measures toward effective enforcement.<sup>428</sup>

They also questioned the assumption that people will pay more for a quieter product:

There is some evidence to indicate that [the assumption that people will pay more for a quieter product] may not be true. For example, people did not elect to pay more for seat belts. . . . There have been some attempts to sell retrofit pollution kits for used automobiles and people elected, in general, not to purchase these kits, even though the cost was only approximately \$20 each installed.<sup>429</sup>

Congress found the argument of the proponents of product noise labels more persuasive than the argument of their opponents. Accordingly, section 8 of the NCA<sup>430</sup> provides for product noise labels.

Under the provisions of section 8, the Administrator issues two types of regulations. The first type designates products or classes of products that produce noise "adversely affecting the public health or welfare"<sup>431</sup> or which are sold "on the basis of [their] effectiveness in reducing noise."<sup>432</sup> The second type of regulation requires that notice be given to prospective users as to the noise level or effectiveness in reducing noise of the product or classes of products designated in the first type of regulation.<sup>433</sup>

---

428. PUBLIC HEARINGS IV, *supra* note 6, at 375 (statement of Dale Hoge, Automotive Parts and Accessories Ass'n). See also *id.* at 322-23 (statement of Ralph W. Van Demark, Motor & Equipment Manufacturers Ass'n).

429. *Id.* at 342 (statement of Thomas C. Young, Engine Manufacturers Ass'n).

430. 42 U.S.C. § 4907 (1976).

431. *Id.* § 4907(a)(1).

432. *Id.* § 4907(a)(2).

433. *Id.* § 4907(b). The second type of regulation specifies (1) the location of the

After proposed regulations have been issued, the Administrator is required to permit "interested persons" to participate in the rulemaking procedure.<sup>434</sup> Notice should be taken that section 8, unlike sections 6 and 18, imposes no statutory deadline for the issuance of labeling regulations.<sup>435</sup> When the Administrator does issue labeling regulations, state and local governments are prohibited from regulating product labeling in such a way as to conflict with the regulations issued pursuant to section 8.<sup>436</sup>

Labeling can be an effective control device. For example, most manufacturers who sell automobiles in the United States have voluntarily agreed to place fuel economy labels on their products. These labels contain the results of tests conducted by EPA and indicate the miles per gallon a purchaser can expect to receive when driving his automobile in suburban and urban areas. Fuel economy labels have had a significant effect on buying habits.<sup>437</sup> Product noise labels might have a similar effect on buying habits.

Unfortunately, product noise labels face two major obstacles. One is the limited scope of section 8. Section 8 does not require either all or most products to be labeled.<sup>438</sup> Only those products that adversely affect public health or welfare or are sold on the basis for their effectiveness in reducing noise are subject to the labeling provisions.

Another obstacle is the lack of enthusiasm for product noise labels exhibited by ONAC personnel. Nothing was done with respect to section 8 until a notice of proposed rulemaking was issued on November 27, 1974, and was published in the *Federal*

---

notice, (2) the form of the notice, and (3) "the methods and units of measurement to be used." *Id.*

434. Section 8(b) of the NCA, 42 U.S.C. § 4907(b) (1976), refers the reader to § 6(c)(2), 42 U.S.C. § 4905(c)(2) (1976). See notes 43-44 and accompanying text *supra*.

435. For a discussion of statutory deadlines, see note 8 *supra*.

436. 42 U.S.C. § 4907(c) (1976). In contrast to state and local noise emission standards, which must be identical to federal noise emission standards, state and local labeling regulations need not be identical with federal labeling regulations. Section 4907(c) is satisfied if the state and local labeling regulations do not conflict with the federal labeling regulations.

437. One indication of the change in buying habits is the sudden emphasis placed on gas mileage in the advertising campaigns of the various automotive manufacturers.

438. During debate on the NCA, Congressman Ryan stated that "[t]he consumer has a right to know the noise emissions of every product he buys." 118 CONG. REC. 6046 (1972). He viewed this lack of knowledge as a critical factor in the rise of noise pollution: "One of the prime reasons that the level of noise has increased so greatly over the past few decades—having doubled since 1955—is that the consumer has been unable to obtain reliable information necessary to take noise as a factor when considering the purchase of a product." *Id.* at 6045-46.

*Register* on December 5, 1974.<sup>439</sup> At that time ONAC announced its plans to designate hearing protectors as a product sold on the basis of its effectiveness in reducing noise and to require hearing protectors to be labeled "according to their noise attenuation capability."<sup>440</sup> The announcement invited the public to participate in the development of such regulations.<sup>441</sup> Proposed Noise Labeling Requirements for Hearing Protectors were issued on June 16, 1977, and were published in the *Federal Register* on June 22, 1977.<sup>442</sup>

Proposed General Provisions for Noise Labeling Standards (Noise Labeling Standards) were issued by ONAC and were published in the *Federal Register* on the same day as the hearing protector regulations.<sup>443</sup> A document designated "Background Document for Product Noise Labeling General Provisions, April, 1977"<sup>444</sup> was published in conjunction with the Noise Labeling Standards and summarizes the information on which they are based.

In the explanatory materials accompanying the Noise Labeling Standards, ONAC outlined four objectives for its noise labeling program:

1. To provide accurate and understandable information to product purchasers and users regarding the acoustic properties of designated products so that meaningful comparisons can be made concerning the acoustic properties of products as part of purchase or use decisions.
2. To [provide] accurate and understandable information to consumers with minimal Federal involvement. . . .
3. To promote public awareness and understanding of environmental noise and the associated terms and concepts.

---

439. 39 Fed. Reg. 42,380 (1974). ONAC's inaction did not go unnoticed. During the NCA extension hearings, one witness, Arthur Fox, was highly critical of EPA's noise program. He indicated that "the Agency has fallen on its face . . . in [the] labeling [area]." *NCA Extension Hearings, supra* note 8, at 58 (statement of Arthur Fox, Director, PROD).

440. 39 Fed. Reg. 42,380 (1974). ONAC solicited information on all aspects of hearing protector labeling but was particularly interested in information about the following aspects: (1) types, makes, and models of hearing protectors, (2) effectiveness of these hearing protectors and the manner and techniques used to relay effectiveness information, (3) methods of classifying hearing protectors, (4) test procedures, (5) shelf life and use life, (6) hazards associated with improper use, (7) suggestions as to the form and content of the label, and (8) domestic and foreign production figures. *Id.*

441. *Id.*

442. 42 Fed. Reg. 31,730 (1977).

443. *Id.* at 31,722.

444. *See id.* at 31,725.

4. To promote effective voluntary noise reduction and noise labeling efforts on the part of product manufacturers and suppliers.<sup>445</sup>

The major purpose of the Noise Labeling Standards is to provide the accurate and understandable information called for in the first two of ONAC's stated objectives.<sup>446</sup> They embody "those aspects of the Agency's noise labeling program which it intends, to the extent practicable, to implement in a uniform manner with respect to the majority of products that will be considered for noise labeling action."<sup>447</sup> Individual products, like hearing protectors, will be dealt with by separate rulemaking action. The explanatory materials do not mention any individual products by name, other than hearing protectors, that will be dealt with by separate rulemaking action, but the products expected to be among the first to be named include vacuum cleaners, air conditioners, shop tools, dishwashers, and powered lawn and garden equipment.<sup>448</sup>

Even though section 8 does not apply to all or even most products, ONAC still finds its coverage overly broad and intends to utilize "further product selection criteria in choosing which particular products or product classes should be considered first for noise labeling action."<sup>449</sup> Sixteen such criteria are listed in the explanatory materials accompanying the Noise Labeling Standards.<sup>450</sup>

### 3. *Acquisition of products*

Since the federal government<sup>451</sup> is a major purchaser of products, section 15 encourages the development of and the purchase

---

445. *Id.* at 31,722.

446. *Id.*

447. *Id.*

448. Washington Post, June 24, 1977, at E-10, col. 3.

449. 42 Fed. Reg. 31,723 (1977).

450. These criteria include: (1) product noise level or noise reduction capability, (2) product population, (3) characteristics of product usage, (4) number of people impacted, (5) effects on public health and welfare, (6) public attitudes towards the product's acoustic performance, (7) existence of noise labeling programs on the part of manufacturers and suppliers, (8) existence of state and local government noise labeling requirements, (9) usefulness of labeled information, (10) potential for product misuse, (11) future trends of product population, design, or usage, (12) existence of product noise emission standards, (13) feasibility of product noise reduction, (14) availability of acoustic information, (15) effects of product usage on third parties, and (16) characteristics of product sales. *Id.*

451. The NCA defines the "Federal Government" as "the legislative, executive, and judicial branches of the Government of the United States, and the government of the District of Columbia." 42 U.S.C. § 4914(a)(2) (1976).



by the federal government of low-noise-emission products.<sup>452</sup> A certification process originally outlined in section 15 has now been supplemented by Low-Noise-Emission Product Certification Procedures (LNEP Regulations). Proposed LNEP Regulations were issued on April 27, 1973, and were published in the *Federal Register* on May 2, 1973.<sup>453</sup> Final LNEP Regulations were issued on February 13, 1974, and were published in the *Federal Register* on February 21, 1974.<sup>454</sup>

The certification process begins when any supplier seeking certification files an application with the Administrator,<sup>455</sup> who thereupon publishes a notice of receipt in the *Federal Register*.<sup>456</sup> The Administrator's initial responsibility is to determine within ninety days after receiving the application whether the product<sup>457</sup> qualifies as a low-noise-emission product<sup>458</sup> and to publish a notice of his determination and the reasons therefore in the *Federal Register*.<sup>459</sup> In making this determination, the Administrator considers whether the product is one for which a noise emission standard has been published, whether the product produces noise in amounts "significantly below" the noise levels set by the applicable noise emission standard, and whether it is properly labeled.<sup>460</sup> He also has discretionary power to conduct investigations, including inspection of the product.<sup>461</sup> In addition, interested parties can submit written comments or documents either in support of or in opposition to the application.<sup>462</sup>

Section 15 permits the Administrator to establish a Low-Noise-Emission Product Advisory Committee (Advisory Com-

452. The NCA defines a "low-noise-emission product" as "any product which emits noise in amounts significantly below the level specified in noise emission standards . . . [issued pursuant to §] 4905 . . . at the time of procurement . . ." *Id.* § 4914(a)(3).

453. 38 Fed. Reg. 10,821 (1973).

454. 39 Fed. Reg. 6670 (1974) (codified in 40 C.F.R. §§ 203.1-8 (1978)).

455. 42 U.S.C. § 4914(b)(5)(A) (1976); 40 C.F.R. § 203.2 (1978).

456. 42 U.S.C. § 4914(b)(5)(B) (1976); 40 C.F.R. § 203.2(c) (1978). The notice of receipt requests interested parties to submit written comments and documents either in support of or in opposition to the application. 42 U.S.C. § 4914(b)(5)(E) (1976).

457. The proposed LNEP Regulations did not define the term "product." This term is defined in the final LNEP Regulations. 40 C.F.R. § 203.1(a)(4) (1978). The final LNEP Regulations adopt the definition of product found in the NCA. See note 29 *supra*.

458. 42 U.S.C. § 4914(b)(5)(F) (1976); 40 C.F.R. § 203.4 (1978).

459. 42 U.S.C. § 4914(b)(5)(G) (1976); 40 C.F.R. § 203.4(b) (1978).

460. 40 C.F.R. § 203.4(a) (1978).

461. 42 U.S.C. § 4914(b)(5)(D) (1976); 40 C.F.R. § 203.3(b) (1978). Tests conducted in conjunction with these investigations are to be in accordance with the procedures contained in the federal noise emission standards issued pursuant to 40 C.F.R. § 203.3(a) (1978).

462. 42 U.S.C. § 4914(b)(5)(E) (1976).

mittee) to assist him in making determinations as to low-noise-emission products.<sup>463</sup> The proposed LNEP Regulations called for such an Advisory Committee.<sup>464</sup> All references to an Advisory Committee were deleted from the final LNEP Regulations.<sup>465</sup>

If the Administrator determines the product is a low-noise-emission product, his next responsibility, after consulting with the appropriate federal agencies,<sup>466</sup> is to decide within 180 days whether the product is a suitable substitute for a product being purchased by the federal government<sup>467</sup> and to publish a notice of his decision and the reasons therefore in the *Federal Register*.<sup>468</sup> This decision theoretically will be based on data obtained from the application, an evaluation of the data, comments of interested parties, and where appropriate, inspection or tests of the product. In reality, the decision probably will be made by asking the federal agency which proposes to procure the product whether the product is a suitable substitute.<sup>469</sup>

A notice of determination can be revoked between determination and decision if "a change in the low-noise-emission product criterion . . . occurs."<sup>470</sup> If the determination as to low-noise-emission status is favorable but the suitable substitute decision is unfavorable, the determination expires as soon as the decision is published.<sup>471</sup>

A certificate is issued if the product is a suitable substitute for a product being purchased by the federal government.<sup>472</sup> This certificate is effective for a one-year period.<sup>473</sup> At the end of this

463. *Id.* § 4914(b)(3). The Advisory Committee is to consist of the Administrator or his designee, a representative of the National Bureau of Standards, and such representatives as the Administrator deems necessary. *Id.*

464. 38 Fed. Reg. 10,822 (1973).

465. The explanatory materials accompanying the final LNEP Regulations simply state that "the administrator has decided to defer establishing the committee until a later date." 39 Fed. Reg. 6670 (1974). This decision may have been prompted by congressional reservations about the need for such a committee. *See generally* 118 CONG. REC. 6036 (1972).

466. *See* note 7 *supra*.

467. 40 C.F.R. § 203.5(a) (1978).

468. 42 U.S.C. § 4914(b)(5)(G) (1976); 40 C.F.R. § 203.5(c) (1978).

469. Common sense dictates that the Administrator make the suitable substitute determination by asking the federal agency currently using a product whether another product, determined to be a low-noise-emission product, is a suitable substitute.

470. 40 C.F.R. § 203.4(c) (1978). Notice of such a revocation is to be published in the *Federal Register* and should include the reasons for the revocation. *Id.*

471. *See id.* §§ 203.4(d), .5(c).

472. *Id.* § 203.5(d). The certificate is to specify with particularity the product or class of products for which the certified product is a suitable substitute. *Id.*

473. *Id.* § 203.5(e).

one-year period, the supplier must apply for recertification. Recertification is approved within thirty days after receipt of an application, provided the data previously submitted continues to describe the product, the determination and decision criteria are the same, and the Administrator has not issued a notice that the permissible noise levels exceed the levels on which certification was based.<sup>474</sup>

At this juncture, responsibility shifts from the Administrator to the General Services Administration (GSA). GSA determines whether the procurement costs of the product which has been certified as a low-noise-emission product are not more than 125% of the retail price<sup>475</sup> of the least expensive product for which the certified product is a substitute.<sup>476</sup> A favorable determination imposes the requirement on federal agencies to purchase available certified products before purchasing any other products for which the low-noise-emission products are certified substitutes.<sup>477</sup> In choosing between competing certified low-noise-emission products, federal agencies are to give priority to the product "which does not require extensive periodic maintenance to retain its low-noise-emission qualities or which does not involve operating costs significantly in excess of those products for which it is a certified substitute."<sup>478</sup>

Both section 15 and the LNEP Regulations call for postcertification testing.<sup>479</sup> If the results of such a test indicate that the actual noise levels exceed the noise levels on which the certification is based, the Administrator notifies the supplier in writing of his findings, publishes his findings in the *Federal Register*, and gives the supplier an opportunity to repair, adjust, or replace the product.<sup>480</sup> An order to show cause why the product should not be

474. *Id.* § 203.8.

475. The NCA defines "retail price" as "(A) the maximum statutory price applicable to any type of product; or (B) in any case where there is no applicable maximum statutory price, the most recent procurement price paid for any type of product." 42 U.S.C. § 4914(a)(4) (1976). Apparently this definition raised a number of questions within various federal agencies. See 39 Fed. Reg. 6670 (1974). The term "retail price" is not used in the LNEP Regulations.

476. 42 U.S.C. § 4914(c) (1976); 40 C.F.R. § 203.6(b) (1978). Both the NCA and the LNEP Regulations provide for the incorporation by reference of data relied upon by the Administrator in determining whether a product is a low-noise-emission product in any procurement contract. 42 U.S.C. § 4914(c)(2) (1976); 40 C.F.R. § 203.6(a) (1978).

477. 42 U.S.C. § 4914(d) (1976). In troubled economic times, there is little likelihood that any federal agency will pay 125% of retail price for a low-noise-emission product.

478. *Id.* § 4914(d).

479. *Id.* § 4914(f); 40 C.F.R. § 203.7 (1978).

480. 40 C.F.R. § 203.7 (1978).

decertified can be issued if the supplier fails to respond to the written notice.<sup>481</sup>

In issuing the final LNEP Regulations, ONAC stated that they "do not contain the low-noise-emission criterion nor do they contain the specific data requirements necessary for deciding whether the product is a 'suitable substitute.'"<sup>482</sup> ONAC moved to correct this situation with Proposed Criteria and Data Requirements, which were issued on May 17, 1977, and published in the *Federal Register* on May 27, 1977.<sup>483</sup>

The noise emission criterion proposed by ONAC in the Proposed Criteria and Data Requirements is 5 dB(A). In order for a product to qualify as a low-noise-emission product, the noise emission level will be approximately 5 dB(A) below the noise level required by the section 6 standard for that product.<sup>484</sup> Five dB(A) is, however, only a guideline. The low-noise-emission level will be set individually for each product at the time of the appropriate section 6 regulation promulgation.<sup>485</sup>

Because the New Truck Regulations contained no LNEP level, the Proposed Criteria and Data Requirements sought to establish LNEP levels by revising section 205.52(e) of the New Truck Regulations. Table II-12<sup>486</sup> shows the proposed LNEP levels for new medium and heavy-duty trucks.

TABLE II-12

Procurement Date	LNEP Level (in dB(A))
January 1, 1977 — December 31, 1980	78
January 1, 1981 — December 31, 1983	75
Thereafter	[Reserved]

Since the New Truck Regulations contain three generations of noise emission standards,<sup>487</sup> the proposed LNEP levels are "5 dB(A) below the noise emission standard that will be in effect for the year following the year in which the product is procured by

481. *Id.*

482. 39 Fed. Reg. 6670 (1974).

483. 42 Fed. Reg. 27,442 (1977).

484. *Id.* at 27,442-43.

485. *Id.* at 27,443.

486. Table II-12 is based on information in 42 Fed. Reg. 27,443 (1977).

487. See notes 294-95 and accompanying text *supra*.

the federal government."<sup>488</sup>

The Proposed Criteria and Data Requirements would establish suitable substitute data requirements by completely revising that section of the LNEP Regulations dealing with applications for certification.<sup>489</sup> They would also delete two terms from the definitional section<sup>490</sup> and amend the section dealing with test procedures.<sup>491</sup>

Congress has authorized appropriations to cover the additional expenses associated with purchasing low-noise-emission products.<sup>492</sup> No funds, however, have actually been appropriated to purchase low-noise-emission products.<sup>493</sup>

488. 42 Fed. Reg. 27,442 (1977).

489. *Id.* at 27, 442-43. The information now includes:

- (1) [Low-noise-emission determination data]:
  - (i) A statement citing the Section 6 standard under which the product is regulated;
  - (ii) A statement . . . certifying that the product . . . [meets] the low-noise-emission level . . . ;
  - (iii) Noise emission data from the manufacturer's test(s) . . . .
- (2) [Suitable substitute determination data]:
  - (i) . . . a statement specifying the product(s) for which suitable substitution is claimed and, if applicable, identification of the Federal procurements specifications . . . ;
  - (ii) Any additional information . . . including . . .
    - (A) Safety . . . ;
    - (B) Performance characteristics;
    - (C) Reliability . . . ;
    - (D) Maintenance . . . ;
    - (E) Operating costs . . . ;
    - (F) Conformance with Federal Agency Purchase Specifications.
  - (iii) [Such information as the procuring agency may request];
  - (iv) [Such amplifying information as the Administrator may request].

*Id.*

490. ONAC deleted definitions of "Low-Noise-Emission Product Determination" and "Suitable Substitute Decision." *Id.* at 27,442.

491. Section 203.3 was amended to specify that the test procedures were the PV procedures for that product. *Id.* at 27,442-43.

492. 42 U.S.C. § 4914(g) (1976). Congress authorized \$1,000,000 for fiscal year 1973, \$2,000,000 for fiscal year 1974, \$2,000,000 for fiscal year 1975, \$2,200,000 for fiscal year 1976, and \$2,420,000 for fiscal year 1977. Senator Buckley thought \$5 million was "simply not necessary in order to achieve desired reduction of noise levels" and felt this amount "could be used more effectively elsewhere." 118 CONG. REC. 35,884 (1972).

493. EPA has taken the position that "[section 15] is geared to the [section 6] regulations and until such regulations are in effect, at least until it is clear what the regulation is going to be in a particular case, we really have no basis for implementing [section 15]." *NCA Extension Hearings, supra* note 8, at 20 (statement of Roger Strelow, Assistant Administrator for Air and Waste Management, EPA). Consequently, EPA has never requested any funds to purchase low-noise-emission products.

#### 4. Federal assistance

Section 14 of the NCA<sup>494</sup> authorizes three types of federal assistance. The Administrator conducts and finances research on the effects, measurement, and control of noise.<sup>495</sup> Pursuant to this authority, ONAC is (1) studying the effects of high-level noise during pregnancy, (2) investigating the effects of protracted noise exposure on blood pressure and heart rate, (3) assessing the relationship between annoyance and intrusiveness of noise sources, (4) studying the effects of high-level, low-frequency noise, and (5) conducting a longitudinal study of the effects of noise on children.<sup>496</sup> ONAC has (1) supported and participated in a multinational seminar on the effects of noise on wildlife,<sup>497</sup> (2) completed two investigations dealing with people's perception of noise and their attitude about their noise environment,<sup>498</sup> (3) completed two joint studies with the United States Air Force Aerospace Medical Research Laboratory,<sup>499</sup> and (4) initiated research and development programs with Purdue University and the National Aeronautics and Space Administration (NASA).<sup>500</sup> During fiscal year 1979 ONAC planned to initiate research and development pro-

---

494. 42 U.S.C. § 4913 (1976). Section 14 was significantly amended by the Quiet Communities Act of 1978. The Quiet Communities Act of 1978 increased ONAC's capacity to aid state and local governments in establishing noise control programs by requiring EPA to fund, through grants, cooperative agreements, or contracts, a variety of activities. For a discussion of the Quiet Communities Act of 1978, see notes 520-22 and accompanying text *infra*.

495. 42 U.S.C. § 4913(1) (1976). Section 4913(1) specifically provides for research on the effects of noise on humans, animals, wildlife, and property; the determination of acceptable noise levels on the basis of these effects; the development of measuring and monitoring techniques; and the determination of effective and practical means of controlling noise.

EPA is authorized to coordinate federal noise research. *See id.* § 4903(c)(1). Pursuant to this authority, EPA established an Interagency Surface Vehicle Noise Research Panel. This panel submitted its first report in 1975. *See* U.S. ENVIRONMENTAL PROTECTION AGENCY, Doc. No. 550/9-75-023, FIRST REPORT ON STATUS AND PROGRESS OF NOISE RESEARCH AND CONTROL PROGRAMS IN THE FEDERAL GOVERNMENT (1975).

496. U.S. ENVIRONMENTAL PROTECTION AGENCY, EPA NOISE CONTROL PROGRAM: PROGRESS TO DATE 8 (1979) [hereinafter cited as 1979 PROGRESS TO DATE].

497. *Id.*

498. *Id.* One study was entitled "Comparison of Various Methods for Predicting the Loudness and Acceptability of Noise"; the other study was entitled "The Urban Noise Survey." *Id.*

499. One of the joint studies with the United States Air Force Aerospace Medical Research Laboratory examined typical noise exposures of Americans; the other joint study examined the effects of noise exposure for periods longer than 24 hours. *Id.* at 9.

500. The Purdue program involves identifying truck noise sources and investigating engine enclosures. *Id.* The NASA program involves developing "quiet" propeller configurations. *Id.*

grams involving (1) quiet truck technology, (2) quiet tire technology, and (3) internal combustion engine technology.<sup>501</sup>

The Administrator provides technical assistance to state and local governments.<sup>502</sup> Pursuant to this authority, ONAC has concentrated its efforts on encouraging the development of state and local noise control programs.<sup>503</sup>

Examples of these activities range from . . . working with the City of Kansas City on the development of a noise ordinance and helping the State of Washington develop and implement a State noise control program . . . [to] supporting the City of Chicago and the State of Florida with programs to determine the contribution of motor vehicles to environmental noise.<sup>504</sup>

In addition, ONAC has undertaken programs aimed at (1) surveying and assessing state and local noise programs,<sup>505</sup> (2) training noise control personnel,<sup>506</sup> (3) developing a noise training man-

501. 1979 PROGRESS TO DATE, *supra* note 496, at 9. Considerable research has already been done on tire noise. *See, e.g.*, LEASURE & CORLEY, SPECTRAL AND DIRECTIONAL CHARACTERISTICS OF NOISE GENERATED BY TRUCK TIRES (U.S. Dep't of Transportation Report No. DOT-TST-75-71, 1975); LEASURE, CORLEY, FLYNN & FORRER, PEAK A-WEIGHTED SOUND LEVELS DUE TO TRUCK TIRES (U.S. Dep't of Transportation Report No. OST/TST-72-1, 1972); and LEASURE, MATHEWS & CADOFF, AUTOMOBILE TIRE NOISE: RESULTS OF A PILOT STUDY AND REVIEW OF THE OPEN LITERATURE (U.S. Dep't of Transportation Report No. DOT-TST-76-4, 1975).

Diesel truck noise has also been the subject of considerable research. *See, e.g.*, LAW, DIESEL ENGINE AND HIGHWAY TRUCK NOISE REDUCTION (SAE Paper No. 730240, 1973); SHRADER, THE REDUCTION OF ENGINE NOISE ON HEAVY DUTY DIESEL TRUCKS (U.S. Dep't of Transportation Report No. DOT-TST-75-88, 1975).

In January 1979 EPA sponsored a noise research technology symposium. The primary objective of this symposium was "to develop a national noise technology research agenda for both the Federal government and the private sector." 1979 PROGRESS TO DATE, *supra* note 496, at 9.

502. 42 U.S.C. § 4913(2) (1976). This assistance consists of advice with respect to selecting and operating equipment, training personnel, and preparing state and local noise laws.

503. 1979 PROGRESS TO DATE, *supra* note 496, at 1.

504. U.S. ENVIRONMENTAL PROTECTION AGENCY, EPA NOISE CONTROL PROGRAM: PROGRESS TO DATE 19 (1978) [hereinafter cited as 1978 PROGRESS TO DATE].

505. ONAC has conducted three surveys. In 1971 ONAC surveyed the 50 states and a number of large cities. 1979 PROGRESS TO DATE, *supra* note 496, at 1.

In 1974 ONAC surveyed 55 states and territories and 235 municipalities. The results of this survey are contained in "State and Municipal Noise Control Activities, 1973-1974." 1978 PROGRESS TO DATE, *supra* note 504, at 19.

In 1978 ONAC surveyed the 50 states and 900 communities with populations over 25,000. The results of this survey describe "the status of State and local noise control programs, their capabilities and activities, and the specific areas in which technical assistance from EPA is needed." 1979 PROGRESS TO DATE, *supra* note 496, at 1.

506. ONAC has conducted over 90 workshops in various locations throughout the country, educating an estimated 3600 officials. 1979 PROGRESS TO DATE, *supra* note 496, at 2. In July 1975 EPA published a document entitled "Guidelines for Developing a

ual,<sup>507</sup> (4) advising state and local governments on “types and uses of sound measurement and analysis instruments,” (5) developing improved methods for measuring and monitoring noise,<sup>508</sup> and (6) preparing model state and local noise legislation.<sup>509</sup> Four other programs should be mentioned: the Quiet Communities Program,<sup>510</sup> the Each Community Helps Others Program,<sup>511</sup> the

---

Training Program in Noise Survey Techniques.” 1978 PROGRESS TO DATE, *supra* note 504, at 19.

507. ONAC is developing a noise training manual for three audiences: decisionmakers, environmental managers, and entry-level noise technicians. 1979 PROGRESS TO DATE, *supra* note 496, at 2.

508. ONAC has developed a community noise monitoring and assessment manual. *Id.* ONAC is also developing a computer-based analysis program called LISTEN (Local Information System to Evaluate Noise) to provide processing and analysis services for communities using this manual. *Id.*

509. ONAC and the Council of State Governments developed and published a model state law in 1974. *Id.* ONAC has also developed a Model Community Noise Control Ordinance. As a complement to the Model Community Noise Control Ordinance, ONAC is developing a Code of Recommended Practices with simple and technically correct local enforcement procedures. *Id.*

510. The Quiet Communities Program is “a pilot project to demonstrate the application of the best available techniques for local noise control. The program includes a community noise assessment program, model local noise control strategy, noise control legislation, and an enforcement program.” *Id.* at 3. ONAC launched its first quiet communities program in Allentown, Pa., in Sept. 1977. *Id.*

According to the Wall Street Journal, the Allentown program received mixed reviews. “The [Allentown, Pa., program] is encountering everything from indifference to disbelief on even the most basic issues: whether Allentown is particularly noisy, for example, and whether governmental bodies can, or should, crack down—or should turn a deaf ear.” Wall St. Journal, Aug. 4, 1978, at 1, col. 4. Although local residents ranked noise as the second most serious problem in Allentown, sentiments among local residents about the Allentown program are sometimes critical. For example, Justice of the Peace William Gilbert views the project as “a big waste of money.” *Id.* George Southworth, executive vice president of the local chamber of commerce, worried about “Big Government”: “I think we’ve got to work toward a better environment, but we’ve got to look at the economic impact.” *Id.*

Allentown has completed the first two stages of its Quiet Communities Program: (1) a comprehensive assessment study to identify and define its noise control needs, and (2) development of a local noise strategy incorporating the assessment data. 1979 PROGRESS TO DATE, *supra* note 496, at 3. At the time 1979 Progress to Date was published, Allentown’s City Council was considering the enactment of a noise control ordinance. ONAC anticipated that this ordinance would be in effect by May 1979. *Id.*

Whatever reservations the citizens of Allentown may have had about the Quiet Communities Program, these reservations are not shared by Congress. After oversight hearings in the Spring of 1978, both the House and Senate Subcommittees recommended that “appropriations for the EPA’s antinoise programs be increased 57%, to \$17 million in fiscal 1980 from \$10.8 million currently. At least \$3 million would go to localities like Springfield, Mo., and Chattanooga, Tenn.—tentative sites for the next Quiet Communities programs.” Wall St. Journal, Aug. 4, 1978, at 1, col. 4.

511. The Each Community Helps Others Program is “[a program] designed to aid communities throughout the United States in developing or improving noise abatement programs through the advice and assistance of noise control experts from other communi-



Senior Environmental Employment Program,<sup>512</sup> and the State Assignee Program.<sup>513</sup>

The Administrator also disseminates information to the public on the effects of noise, acceptable noise levels, and techniques for noise measurement and control.<sup>514</sup> Pursuant to this authority, ONAC is developing (1) two noise curriculum modules to be used in junior and senior high schools as a part of the science curriculum, (2) a noise curriculum module to be used in the apprenticeship training program of the International Union of Operating Engineers, (3) a curriculum unit to be used in the Law Enforcement Apprenticeship Program of the Department of Labor's Bureau of Apprenticeship and Training, (4) three brochures for school children and young adults to be distributed when hearing tests are given, (5) an eight-minute film ("A Quiet World: It's Up to Us"), and (6) six publications (*Noise: A Health Problem; Noise and Your Hearing; Hear, Here; Think Quietly About Noise; Quieting in the Home; and ECHO*).<sup>515</sup>

At the time section 14 was being drafted, there was sharp disagreement about the need for a program of federal grants-in-aid. Proponents of a grants-in-aid provision argued that the financial squeeze faced by state and local governments dictated a grants-in-aid program.<sup>516</sup> Opponents countered that the money

---

ties." 1979 PROGRESS TO DATE, *supra* note 496, at 3. ONAC initiated this program in Jan. 1978. *Id.* Approximately 55 communities have received assistance to date. *Id.* at 4.

512. The Senior Environmental Employment Program is funded by a grant from the Department of Health, Education and Welfare's Administration on Aging and is designed to provide meaningful employment to workers 55 years of age and older. *Id.* Older workers have been used to provide one person-year of support to each of the Noise Program Chiefs found in EPA's Regional Offices. *Id.* Older workers can also be used at the local level. Allentown, Pa., for example, used 40 older workers to conduct a survey. *Id.*

513. The State Assignee Program is "a program in which professionals are hired by [EPA] and detailed to the appropriate State Office for a two year period." *Id.* This program was initiated in 1978 and currently involves one position each in ten states: California, Connecticut, Florida, Iowa, Maryland, Michigan, New Mexico, New York, North Dakota, and Washington. *Id.* at 5.

514. 42 U.S.C. § 4913(3) (1976).

515. 1979 PROGRESS TO DATE, *supra* note 496, at 6-7.

516. The Senate bill authorized a grants-in-aid program. The need for such a program was described by Senator John V. Tunney:

States and cities are becoming increasingly frustrated at their inability to deal effectively with local noise problems: caught in a financial squeeze, they lack the tools and training to do the job they need . . . . In the past year alone, EPA has received requests from 28 States and 111 cities for technical and financial assistance—demands it has no authority to meet under present law.

118 CONG. REC. 35,387 (1972).

A number of local government leaders favored a grants-in-aid program. *See, e.g., PUBLIC HEARINGS II, supra* note 260, at 6 (statement of Herbert W. Poston, Commissioner

proposed to be spent for grants-in-aid could be more effectively spent elsewhere.<sup>517</sup> This disagreement carried over to the Senate and House bills: the House bill did not authorize a grants-in-aid program, the Senate bill did authorize such a program.<sup>518</sup> Section 14, as originally enacted, did not authorize a program of federal grants-in-aid. Additionally, no grants-in-aid program was added when Congress voted to extend the NCA in 1975.<sup>519</sup>

As a result of testimony during the congressional oversight hearings in the spring of 1978, Congress became aware of the need to develop more effective state and local noise control programs, the need to expand ONAC's public education/information program, and the need to provide increased funding for technical assistance at the state and local government level.<sup>520</sup> This awareness led to the enactment of the Quiet Communities Act of 1978. The Quiet Communities Act amended section 14, providing for the loan of equipment to state and local governments and for the funding, through grants, cooperative agreements, or contracts, of (1) financial assistance to state and local governments for, among other things, transportation noise abatement, (2) regional technical assistance centers, (3) staffing and training assistance

---

of the Dep't of Environmental Control, Chicago, Ill.); PUBLIC HEARINGS IV, *supra* note 6, at 15-16 (statement of Wes Uhlman, Mayor of Seattle, Wash.), 268 (statement of Nicholas Yost, Deputy Attorney General, Calif.).

The House bill authorized no grants-in-aid program. Congressmen Mikva, Ryan, and Drinan were sharply critical of the failure to authorize. 118 CONG. REC. 6043-47 (1972). Congressman Mikva's remarks are typical:

The most important deficiency in the Noise Control Act is the absence of any authority or funds for making grants to State and local governments to help them devise and implement noise pollution control programs, including demonstration projects. As the administration said repeatedly in testimony last year before the House Subcommittee on Public Health and the Environment, noise pollution must be attacked at the local level. State and local governments have attempted to deal with noise through antinoise ordinances and zoning laws, but their efforts have been unsuccessful in reducing noise levels in our urban communities. Local governments simply do not have enough trained personnel to undertake proper monitoring and enforcement.

*Id.* at 6043.

517. Senator Buckley questioned the wisdom of such a provision and asked rhetorically: "Would it not be better for the Federal Government to use the limited amount of money which would be available to enhance the technical assistance and the information base which would be of great value to State and local authorities?" 118 CONG. REC. 35,884 (1972).

518. The Senate bill, S. 1016, authorized a grants-in-aid program of \$22.5 million over a three-year period. S. REP. 92-1160, *supra* note 5, at 11. Grants-in-aid were limited to two-thirds of planning and development costs and one-half of maintenance costs. *Id.* No one state could receive more than ten percent of the total funds available. *Id.*

519. See 118 CONG. REC. 37,088 (1975).

520. 1979 PROGRESS TO DATE, *supra* note 496, at v.

to state and local governments, (4) use of older workers in the Senior Environmental Employment Program, and (5) increased noise research.<sup>522</sup>

### 5. Enforcement of the NCA

Section 11 of the NCA<sup>523</sup> discusses enforcement.<sup>524</sup> The NCA can be enforced by criminal sanctions, with jurisdiction vested in the federal district courts.<sup>525</sup> The following penalties can be imposed: "Any person<sup>526</sup> who willfully or knowingly violates [paragraphs (a)(1), (a)(3), (a)(5), or (a)(6) of section 10 of the NCA]<sup>527</sup> shall be punished by a fine of not more than \$25,000 per day of violation, or by imprisonment for not more than one year, or by both."<sup>528</sup> Each day of violation constitutes a separate violation.<sup>529</sup>

The NCA can also be enforced by an order issued by the Administrator and specifying the relief he deems necessary to protect public health and welfare.<sup>530</sup> No such order, however, can be issued until the Administrator has complied with the notice and hearing requirements of the Administrative Procedure Act.<sup>531</sup> Such an order is the only civil sanction currently available under the NCA. This situation may change. Congress has considered several bills which would enlarge EPA's authority to impose civil

521. Pub. L. No. 95-609, 92 Stat. 3079 (1978).

522. 1979 PROGRESS TO DATE, *supra* note 496, at vi.

523. 42 U.S.C. § 4910 (1976).

524. The enforcement provisions in the NCA are similar to the enforcement provisions in the Clean Air Act. See 118 CONG. REC. 37,086 (1972).

525. 42 U.S.C. § 4910(c) (1976).

526. As used in § 11, the term "person" does not include "a department, agency or instrumentality of the United States." *Id.*

527. Paragraph (a)(1) prohibits distribution of a new product which does not conform to a federal noise emission standard. *Id.* § 4909(a)(1). Paragraph (a)(3) prohibits distribution of a product which does not conform to the labeling regulations. *Id.* § 4909(a)(3). Paragraph (a)(5) prohibits importation of a product which does not conform to the import regulations. *Id.* § 4909(a)(5). Paragraph (a)(6) prohibits noncompliance with any requirement of §§ 11(d) (orders issued to protect the public health and welfare), 13(a) (duties of manufacturers), or regulations issued under §§ 13(a) (duties of manufacturers), 17 (railroad noise emission standards), or 18 (interstate motor carrier noise emission standards). *Id.* § 4909(a)(6).

528. *Id.* § 4910(a). Second convictions are punishable by "a fine of not more than \$50,000 per day of violation, or by imprisonment for not more than two years or by both." *Id.*

529. *Id.* § 4910(b).

530. *Id.* § 4910(d)(1).

531. *Id.* § 4910(d)(2). The notice and hearing requirements of the Administrative Procedure Act are codified in 5 U.S.C. §§ 554, 556 (1976).

sanctions.<sup>532</sup>

Within EPA are two offices responsible for noise. One such office is the Office of Noise Abatement and Control. ONAC prepares and issues noise regulations. ONAC was created by the Noise Pollution and Abatement Act of 1970.<sup>533</sup> ONAC has seventy-six positions, including administrators, environmental engineers, lawyers, and support staff.<sup>534</sup> During fiscal year 1979 ONAC anticipates that the number of positions will drop to sixty-eight.<sup>535</sup>

The other office within EPA is the Office of Mobile Source and Noise Enforcement, particularly its Noise Enforcement Division (NED). NED enforces section 6 regulations. NED came into existence during fiscal year 1974.<sup>536</sup> Twenty-four of the positions within NED are in the central office; the remaining twelve are in the regional offices.<sup>537</sup> All of the regional personnel are environmental engineers; the central office personnel are approximately equally divided between environmental engineers and lawyers. During fiscal year 1979 NED anticipates that the number of total positions will increase to thirty-seven.<sup>538</sup> There will be twenty-two

532. [1978] NOISE REG. REP. (BNA) No. 104, A-34 to A-35 (May 8, 1978).

533. 42 U.S.C.A. § 7641 (West Pamph. Supp. 1978). Under the provisions of the Noise Pollution and Abatement Act of 1970, ONAC had the responsibility of conducting an investigation of noise and its effects on public health and welfare. The purposes of this investigation were to (1) "identify and classify causes and sources of noise" and (2) "determine [inter alia] effects at various [noise] levels; projected growth of noise levels in the urban areas through the year 2000 . . . [and] effects of sporadic . . . noise . . . as compared with constant noise . . . ." *Id.*

ONAC conducted the required investigation in 1971, and the results of this investigation were published in a series of documents. *See, e.g.*, U.S. ENVIRONMENTAL PROTECTION AGENCY, NOISE FROM CONSTRUCTION EQUIPMENT AND OPERATIONS, BUILDING EQUIPMENT, AND HOUSE APPLIANCES (1971); U.S. ENVIRONMENTAL PROTECTION AGENCY, NOISE FROM INDUSTRIAL PLANTS (1971); U.S. ENVIRONMENTAL PROTECTION AGENCY, COMMUNITY NOISE (1971); U.S. ENVIRONMENTAL PROTECTION AGENCY, LAWS AND REGULATORY SCHEMES FOR NOISE ABATEMENT (1971); U.S. ENVIRONMENTAL PROTECTION AGENCY, EFFECTS OF NOISE ON PEOPLE (1971); U.S. ENVIRONMENTAL PROTECTION AGENCY, SUMMARY OF NOISE PROGRAMS IN THE FEDERAL GOVERNMENT (1971); U.S. ENVIRONMENTAL PROTECTION AGENCY, ECONOMIC IMPACT OF NOISE (1971). In accordance with the provisions of § 7641(a), the Administrator reported the results of this investigation and made legislative recommendations. This document, entitled *Report to the President and Congress on Noise*, was transmitted to the President and the Senate on Jan. 24, 1972. U.S. ENVIRONMENTAL PROTECTION AGENCY, REPORT TO THE PRESIDENT AND CONGRESS ON NOISE, S. DOC. NO. 63, 92d Cong., 2d Sess. (1972).

534. 1979 PROGRESS TO DATE, *supra* note 496, at 5. For an organizational chart of ONAC, see *id.* at 26.

535. *Id.* at 25.

536. *Id.* For an organizational chart of NED, see *id.* at 27.

537. *Id.* at 25.

538. *Id.*

positions in the central office and fifteen positions in regional offices.

NED began to enforce the New Truck Regulations in January 1978.<sup>539</sup> Since January 1978 NED has inspected the facilities of fourteen truck manufacturers and conducted six SEA's.<sup>540</sup> Vehicles have been recalled for repair or modification in four instances.<sup>541</sup> NED is also devoting considerable resources to developing noise enforcement training materials for state and local police officers.<sup>542</sup>

Section 19 of the NCA, as originally enacted, authorized the following appropriations for EPA's noise effort under the NCA: \$3,000,000 for fiscal year 1973, \$6,000,000 for fiscal year 1974, and \$12,000,000 for fiscal year 1975.<sup>543</sup> In 1975 Congress extended the NCA and authorized the following appropriations: \$19,250,000 for fiscal year 1976<sup>544</sup> and \$16,940,000 for fiscal year 1977.<sup>545</sup> Table II-13<sup>546</sup> shows actual appropriations since fiscal year 1971.

539. Telephone conversation with NED personnel (Aug. 1978).

540. 1979 PROGRESS TO DATE, *supra* note 496, at 17.

541. *Id.*

542. *Id.*

543. Noise Control Act of 1972, Pub. L. No. 92-574, § 19, 86 Stat. 1234 (codified at 42 U.S.C. § 4918 (1976)).

544. In 1976 Congress shifted from the old fiscal year to a new fiscal year. Consequently, the authorized appropriation for fiscal year 1976 was composed of \$15,400,000 for the old fiscal year 1976 plus \$3,850,000 for the transition period from July 1, 1976 to Sept. 30, 1976.

545. Noise Control Act Extension, Pub. L. No. 94-301, § 2, 90 Stat. 590 (1975). At the time Congress voted to extend the NCA, Congressman Rogers remarked that "[i]t is indeed unfortunate that this program has been so slow in developing and that 3 years later we must vote to extend it because there has not been enough of a beginning made to know whether the law needs changing or not." 121 CONG. REC. 25,553 (1975).

546. Table II-13 is based on a table in 1979 PROGRESS TO DATE, *supra* note 496, at 25.

TABLE II-13

Fiscal Year	Appropriations (millions of dollars)	
	ONAC	NED
1971	0.3	0
1972	1.2	0
1973	2.7	0
1974	4.2	0.0206
1975	5.1	0.0208
1976	9.8	0.385
1977	9.8	0.707
1978	10.3	1.027

In fiscal year 1979 ONAC's requested budget is \$10,000,000, and NED's requested budget is \$916,000.<sup>547</sup>

Lack of sufficient funds has hampered ONAC's activities in the past. Russell Train, the Administrator in 1974, indicated that a lack of sufficient funds was the principal problem faced by ONAC.<sup>548</sup> As a result of insufficient funds, ONAC was understaffed and had been forced to rely too heavily on outside contractors.<sup>549</sup> There have been further indications that this problem may be a continuing one. In 1975, for example, the Senate Public Works Committee recommended that \$5,000,000 of ONAC's \$10,200,000 budget request for fiscal year 1976 be transferred to the Office of Air and Waste Management because air pollution was regarded as a more serious threat than noise.<sup>550</sup> This recommendation was subsequently rejected. Today, ONAC personnel are cautiously optimistic.<sup>551</sup>

NED does not enforce the Motor Carrier Regulations/Motor Carrier Compliance Regulations. These section 18 regulations are

547. *Id.*

548. [1974] ENVIR. REP. (BNA) 1796 (Mar. 1, 1974). This lack of sufficient funds is partially attributable to the low priority noise receives at EPA. In his 1975 budget request, Russell E. Train indicated that "we are holding the Noise Program to a low level of growth and consciously stretching out the full implementation of the 1972 Act." Letter from Russell E. Train, Administrator, EPA, to Ray Ash, Director, OMB, *reprinted in NCA Extension Hearings, supra* note 8, at 43.

549. [1974] ENVIR. REP. (BNA) 1796 (Mar. 1, 1974).

550. [1974] ENVIR. REP. 1835 (Mar. 21, 1975).

551. There is even talk of increasing ONAC's budget. See note 510 *supra*.

enforced by the Bureau of Motor Carrier Safety, a bureau within the Federal Highway Administration (FHWA).<sup>552</sup>

BMCS has 126 safety inspectors who operate in nine regions.<sup>553</sup> These safety inspectors have jurisdiction over approximately 5.2 million motor vehicles operated by interstate motor carriers.<sup>554</sup> Safety inspectors enforce the Motor Carrier Safety Regulations.<sup>555</sup> This responsibility would be a large one even under ideal conditions; the responsibility becomes enormous when a significant percentage of the motor vehicles are found in violation of the Motor Carrier Safety Regulations.<sup>556</sup>

In addition to enforcing the Motor Carrier Safety Regulations, safety inspectors, beginning in the spring of 1976, began to enforce two noise standards for motor vehicles operated by interstate motor carriers. The first noise standard, an exterior noise standard, is found in the Motor Carrier Regulations/Motor Carrier Compliance Regulations; the second noise standard, an interior noise standard, is found in regulations issued by BMCS.<sup>557</sup>

Safety inspectors conduct compliance checks at roadside sites and terminal surveys. The results of compliance checks are forwarded to BMCS's national headquarters in Washington, D.C., where one individual has the responsibility for compiling and preparing reports to be placed on computer.<sup>558</sup> This same individual also acts as BMCS's liaison with ONAC.<sup>559</sup>

During the first months of enforcement, the violation rate was approximately ten percent.<sup>560</sup> Table II-14<sup>561</sup> shows the percen-

552. The Federal Highway Administration is one of seven divisions within the Department of Transportation.

553. Interview with Arthur McAndrew, BMCS (Apr. 28, 1978).

554. U.S. ENVIRONMENTAL PROTECTION AGENCY, *supra* note 109, at 64.

555. 49 C.F.R. §§ 390-398 (1978).

556. During his testimony, Arthur Fox, Director, PROD, stated: "Some 40 percent of the equipment on the highway being spot checked today is being found to be in imminently hazardous condition." *NCA Extension Hearings, supra* note 8, at 59.

BMCS began an unannounced intensive inspection program in Sept. 1977. *Washington Post*, Aug. 26, 1978, at A-2, col. 1. During a spot check on a busy Pennsylvania highway between Aug. 7 and 11, 1978, 382 out of 711 trucks "were immediately ordered off the road because they were too poorly maintained to be safe . . ." *Id.* "[Two hundred eighty-six] trucks . . . had faulty or virtually inoperative braking systems . . ." *Id.* "Forty trucks were removed . . . for inoperative lights, 25 for bad suspension systems and 21 for tire problems." *Id.* See also *Washington Post*, Sept. 20, 1978, at B-1, col. 1.

557. 49 C.F.R. § 393.94 (1978).

558. Interview with Arthur McAndrew, BMCS (Apr. 28, 1978).

559. *Id.*

560. *Id.*

561. Table II-14 is based on information supplied to the author by BMCS (Apr. 28, 1978).

tage of vehicles that passed or failed the exterior and interior noise levels tests conducted by BMCS.

TABLE II-14

Type of Test	Percentage Results	
	Passed	Failed
<b>Exterior</b>		
October 15, 1975 — December 31, 1976	97.2	2.8
January 1, 1976 — December 31, 1977	96.6	3.4
<b>Interior</b>		
January 1, 1976 — December 31, 1976	97.1	2.9
January 1, 1977 — December 31, 1977	83.6	16.4

As these percentages indicate, most vehicles satisfy the noise emission standards of the Motor Carrier Regulations. This raises the question whether the existing noise emission standards continue to reflect best available technology. BMCS personnel concede that the noise emission standards are too high and could be lowered.<sup>562</sup>

BMCS's experience with the measurement procedure that was adopted in the Motor Carrier Compliance Regulations confirms the serious environmental limitations ascribed to SAE Standard J366b,<sup>563</sup> even when SAE Standard J366b is modified.<sup>564</sup> Tests can only be conducted at large open sites.<sup>565</sup> As a result, tests in heavily populated areas are impractical, if not impossible. Tests can only be conducted under favorable weather conditions.<sup>566</sup> As a result, tests must be conducted on a seasonal basis.<sup>567</sup> BMCS, moreover, has noted geographical variations.<sup>568</sup> In part,

562. BMCS personnel were unwilling to speculate on what the noise emission standard should be, based on "best available technology."

At least one organization has taken the position that the Motor Carrier Compliance Regulations are not only too lenient now but were also too lenient and permitted noise degradation at the time of their adoption. *NCA Extension Hearings, supra* note 8, at 36 (statement of Arthur Fox, Director, PROD).

563. See notes 139-45 and accompanying text *supra*.

564. BMCS adopted a modified version of SAE Standard J366b in the Motor Carrier Compliance Regulations. See notes 146-62 and accompanying text *supra*.

565. See note 143 and accompanying text *supra*.

566. See note 145 and accompanying text *supra*.

567. Testing usually is conducted between April and October.

568. For example, violations in the southeastern portion of the United States are higher than elsewhere. Interview with Toni Sylvie, BMCS (Apr. 28, 1978).



these geographical variations are due to weather conditions. Wind, for example, is a serious obstacle in the Plains States.<sup>569</sup>

In addition to these problems, BMCS has experienced morale problems. Some safety inspectors ask themselves, "Why am I standing here measuring noise when 97% of the vehicles pass the test?" BMCS has responded to this problem by introducing new gadgetry. For example, all nine regions now have at least one set of two-way radios.<sup>570</sup>

### B. *Federal-Aid Highway Act*

Federal-aid highways can be grouped into four systems. The "interstate system", consisting of 41,000 miles of highway, connects "the principal metropolitan areas, cities, and industrial centers."<sup>571</sup> An "urban system" serves "the major centers of activity" and includes "high traffic volume arterial and collector routes."<sup>572</sup> The "primary system" consists of "an adequate system of connected main highways" selected or designated by state highway officials and approved by the [Secretary].<sup>573</sup> A "secondary system" includes "farm-to-market roads, rural mail routes, public school bus routes, local rural routes, access roads to airports, county roads, township roads, and roads of the county road class" selected by state and local highway officials and approved by the Secretary.<sup>574</sup>

#### 1. *Provisions of the Act*

Standards for federal-aid highways under the Federal-Aid Highway Act (FAHWA) are found in 23 U.S.C. § 109.<sup>575</sup> Section 109 has been amended on several occasions in recent years to add provisions dealing with noise. Subsection (h) and subsection (i)

569. *Id.*

570. *Id.*

571. 23 U.S.C. § 103(e) (1976).

572. *Id.* § 103(d).

573. *Id.* § 103(b).

574. *Id.* § 103(c).

575. (1976). These standards have evolved over time as the goals and priorities of the federal-aid highway program have shifted. "In the 1920's and 1930's [FHWA was] attempting to establish a nationwide system of roads and provide all-weather surfaces. In the 1940's and 1950's . . . greater emphasis was placed on the needs of the traveling public by providing" stronger and wider pavements, increased sight distance, flatter horizontal curves, grade separation structures, and limited access highways . . . During the 1960's, emphasis was placed on safety and beauty. The emphasis of the 1970's is concern for the environment." PUBLIC HEARINGS II, *supra* note 260, at 94 (statement of Harter M. Rupert, FHWA).

were added to section 109 in 1970.<sup>576</sup> Subsection (h) requires the Secretary to formulate guidelines after consultation with appropriate federal and state officials but not later than July 1, 1972.<sup>577</sup> These guidelines are designed to insure a final decision on a proposed highway project that reflects "the best overall public interest." Among the factors to be considered in ascertaining "the best overall public interest" are "the need for fast, safe and efficient transportation" and "the costs of eliminating or minimizing . . . noise."<sup>578</sup> These guidelines are initially submitted to Congress and are then issued as proposed guidelines within ninety days after submission to Congress.<sup>579</sup>

Proposed Process Guidelines for the Development of Environmental Action Plans (Subsection (h) Guidelines) were issued by the Federal Highway Administration on October 29, 1973, and were published in the *Federal Register* on November 1, 1973.<sup>580</sup> Final Subsection (h) Guidelines were issued November 26, 1974, and were published in the *Federal Register* on December 2, 1974.<sup>581</sup>

The goal of the Subsection (h) Guidelines is full of consideration of the possible adverse social, economic, and environmental effects of a proposed highway project from the system planning stage,<sup>582</sup> through the location stage,<sup>583</sup> to the design stage,<sup>584</sup> and the incorporation of these considerations into the decisionmaking process.<sup>585</sup> A three-step program is outlined:

- (1) Social, economic, and environmental effects [are] identified and studied early enough to permit analysis and consideration while alternatives are being formulated and evaluated.

576. Pub. L. No. 91-605, § 136(b), 84 Stat. 1713 (1970).

577. 23 U.S.C. § 109(h) (1976).

578. See *id.* For a discussion of the interaction between environmental and transportation policies, see Aurbach, *Environmental Policy and Urban Transportation (Urban Freeway Manifesto Revisited)*, 3 URB. LAW. 713 (1971); Cech, *Environmental Attacks on Highway Planning Under NEPA: When Is There "Federal Action"?*, 7 CONN. L. REV. 733 (1975).

579. 23 U.S.C. § 109(h) (1976).

580. 38 Fed. Reg. 30,192 (1973).

581. 39 Fed. Reg. 41,804 (1974) (codified in 23 C.F.R. §§ 795.1-17 (1979)).

582. The "system planning stage" involves "[r]egional analysis of transportation needs and the identification of transportation categories." 23 C.F.R. § 795.2(e)(1) (1979).

583. The "location stage" begins with "the end of system planning [and continues] through the selection of a particular location." *Id.* § 795.2(e)(2).

584. The "design stage" begins with "the selection of a particular location [and continues] to the start of construction." *Id.* § 795.2(e)(3).

585. *Id.* § 795.3(a).

(2) Other agencies and the public [are] involved in system planning and project development early enough to influence technical studies and final decisions.

(3) Appropriate consideration [is] given to reasonable alternatives, including the alternative of not building the project and alternative modes.<sup>586</sup>

FHWA's program emphasizes a process approach; thus, the Subsection (h) Guidelines are designated as "process guidelines."

Under the Subsection (h) Guidelines each state highway agency has the responsibility to develop and implement an approved "Action Plan."<sup>587</sup> These Action Plans describe the organization<sup>588</sup> and the procedures to be followed by the state in identifying social, economic, and environmental effects<sup>589</sup> and providing this information on a "timely" basis to other agencies and the general public.<sup>590</sup> Action Plans have been developed by all fifty states and approved by FHWA.<sup>591</sup>

Two aspects of the Subsection (h) Guidelines should be emphasized. They are prospective in effect. They apply to future development on ongoing projects and to future projects.<sup>592</sup> They are also implemented in stages.<sup>593</sup> All aspects of each Action Plan were to have been implemented by November 1, 1974.<sup>594</sup> If a state

586. *Id.* § 795.3(b).

587. *Id.* § 795.3(a). Action Plans should be consistent with FHWA regulations and directives. *Id.* § 795.5(b). Officials of local, state, and federal agencies and members of the general public should be involved in the development of the Action Plan. *Id.* § 795.5(c). FHWA should assist and advise the state in developing an Action Plan. *Id.* § 795.5(d). The Action Plan should be submitted to the Governor for review and approval. *Id.* § 795.5(e). The Action Plan should then be submitted to the appropriate Regional Federal Highway Administrator for review and approval. *Id.* § 795.5(g). The Action Plan submitted to the Governor and the Regional Federal Highway Administrator should contain (1) a description of the procedures followed in developing the plan, (2) the steps taken to involve agencies and the general public in developing the plan, (3) a summary of comments received on the plan, and (4) the actions taken with respect to these comments. *Id.* § 795.5(f).

588. The Action Plan identifies who is responsible for (1) providing information on social, economic, and environmental effects of various alternative courses of action; (2) controlling the quality of social, economic, and environmental studies; and (3) monitoring social, economic, and environmental research and state-of-the-art developments. *Id.* § 795.8(b).

589. The effects, "both beneficial and adverse, of alternative courses of action should be [identified] as early in the study process as feasible." *Id.* § 795.8(a).

590. *Id.*

591. Telephone conversation with Harter M. Rupert, Office of Environmental Policy, FHWA (Dec. 14, 1979).

592. 23 C.F.R. § 795.4(b) (1979).

593. *Id.* § 795.6(b).

594. *Id.* The regulations provided for the submission of a schedule for the implemen-

highway agency fails to maintain the implementation schedule approved by FHWA, FHWA can withhold location approvals or take "such other actions as it deems appropriate."<sup>595</sup>

Subsection (i) requires the Secretary to develop and publish noise level standards for federal-aid highways. Under the 1970 version of subsection (i), the Secretary consulted with federal, state, and local officials when developing the noise level standards. These noise level standards applied solely to proposed projects for which location approval<sup>596</sup> was secured after July 1, 1972. The Secretary could grant design approval<sup>597</sup> or approval of plans and specifications for such projects only if "he determine[d] that the plans and specifications include[d] adequate measures to implement the appropriate noise level standard."<sup>598</sup>

Noise level standards were developed by FHWA in 1971.<sup>599</sup> Two years elapsed, however, before Noise Standards and Procedures (Subsection (i) Regulations) were issued on February 8, 1973, and were published in the *Federal Register* on June 19, 1973.<sup>600</sup>

Congress, meanwhile, decided to amend subsection (i), and these amendments were enacted in 1973.<sup>601</sup> One change was mandatory and involved the consultation process. Under the 1973 version of subsection (i), the Administrator of EPA was added to the list of parties to be consulted by the Secretary when he is developing noise level standards.<sup>602</sup> The other changes were permissive rather than mandatory and involved the scope of subsection (i). Noise level standards may now be applied to previously constructed projects, *i.e.*, projects for which location approval had been secured prior to July 1, 1972.<sup>603</sup> In addition, the Secre-

---

tation of its Action Plan by any state highway agency which "believes that any provision of its Action Plan cannot be implemented prior to November 1, 1974." *Id.* FHWA considered such schedules on a case-by-case basis.

595. *Id.* § 795.6(c).

596. "Location approval" is "[t]he approval given by [FHWA] (at the request of a State highway department) based upon a location study report and a corridor public hearing or opportunity therefor." 23 C.F.R. 772.2(h) (1973).

597. "Design approval" is "[t]he approval given by [FHWA] based upon a design study report and a design public hearing or opportunity therefor." 23 C.F.R. § 772.2(a) (1973).

598. 23 U.S.C. § 109(i) (1976).

599. FEDERAL HIGHWAY ADMIN., NOISE STANDARDS AND PROCEDURES (1972) [hereinafter cited as NOISE STANDARDS].

600. 38 Fed. Reg. 15,953 (1973).

601. Pub. L. No. 93-87, § 114, 87 Stat. 250 (1973).

602. *Id.*

603. *Id.*

tary may approve noise abatement measures as highway projects. Such noise abatement measures include, but are not limited to, "the acquisition of additional rights-of-way, the construction of physical barriers, and landscaping."<sup>604</sup> As a result of these permissive changes, federal funds became available to finance the federal share of noise abatement measures on proposed and previously constructed projects.

These changes prompted FHWA to solicit ideas on proposed policies and procedures for noise abatement on previously constructed projects.<sup>605</sup> The resulting comments showed not only the need for the proposed policies and procedures but also the need to revise the existing Subsection (i) Regulations.<sup>606</sup> Since such a revision would be time consuming, interim regulations were developed to handle the immediate problem of regulations for noise abatement projects on previously constructed projects.<sup>607</sup>

In 1974 FHWA summarized the intent of the Subsection (i) Regulations as follows:

[The noise level standards] require: (1) a thorough analysis and assessment of noise effects on Federal highway projects, (2) incorporation of noise abatement measures into those highway projects where they will be both feasible and effective, and (3) creation of an awareness on the part of local officials that measures can and should be taken to assure that future development of currently undeveloped lands be performed in a manner that will be compatible (from a noise standpoint).<sup>608</sup>

Noise level standards assure that "measures are taken in the overall public interest to achieve highway noise levels that are compatible with different land uses."<sup>609</sup> They also assure that "due consideration" is to be given to "other social, economic, and environmental effects" in achieving the goal of compatibility.<sup>610</sup>

Proper revisions to the Subsection (i) Regulations were issued on September 5, 1974, and were published in the *Federal*

604. *Id.*

605. Federal Highway Admin., Report on Promulgation of "Procedures for Abatement of Highway Traffic Noise and Construction Noise", Federal-Aid Highway Program Manual, Volume 7, Chapter 7, Section 3, at 2 (Nov. 17, 1976) [hereinafter cited as FHPM 7-7-3].

606. *Id.*

607. 39 Fed. Reg. 6696-97 (1974). When the interim regulations were published, FHWA indicated that 23 C.F.R. §§ 772.1-.7, .30 would be replaced by amended Subsection (i) Regulations that would be issued by mid-1974. *Id.*

608. NOISE STANDARDS, *supra* note 599, at 4.

609. 23 C.F.R. § 772.1 (1973).

610. *Id.*

*Register* on September 10, 1974.<sup>611</sup> These proposed revisions represented "an integration of the mandatory requirements of the 1970 Act with the permissive authority granted by the 1973 Act."<sup>612</sup> They were designed "to establish comprehensive policies and procedures for dealing with the abatement of highway traffic noise and highway related construction noise."<sup>613</sup>

Final revisions to the Subsection (i) Regulations were issued on April 16, 1976, and were published in the *Federal Register* on April 23, 1976.<sup>614</sup> In the explanatory materials accompanying the final revisions, FHWA summarized thirteen "major points" raised in comments from different sources<sup>615</sup> and indicated the disposition of each.<sup>616</sup>

---

611. 39 Fed. Reg. 32,616 (1974).

612. *Id.* FHWA's response to the mandatory requirements of the 1970 Act resulted in 23 C.F.R. §§ 772.1-.7. FHWA's response to the permissive requirements of the 1973 Amendment was 23 C.F.R. § 772.30.

613. 39 Fed. Reg. 32,616 (1974).

614. 41 Fed. Reg. 16,933 (1976).

615. FHWA received comments from 124 sources. FHPM 7-7-3, *supra* note 605, at 4.

616. The major points were reflected in various comments:

1. Several comments suggested that the term "design noise levels" be replaced by the term "maximum acceptable noise levels." FHWA rejected this suggestion.

2. Several comments requested definitions of "existing noise level" and "ambient noise level." FHWA clarified the first term but did not include the second term in the regulations.

3. Several comments requested clarification of the applicability provisions. FHWA stressed that the revised Subsection (i) Regulations are prospective.

4. Several comments addressed the relevance of the Subsection (i) Regulations to low volume highways. FHWA replied that the Subsection (i) Regulations, as written, were sufficiently flexible.

5. Several comments suggested that noise levels be predicted for the date of project completion rather than the design year. FHWA rejected this suggestion.

6. Several comments suggested that existing noise levels should be measured rather than calculated. FHWA replied that the Subsection (i) Regulations, as written, were sufficiently flexible.

7. Several comments suggested that the FHWA approach to noise abatement was too complex. FHWA partially agreed and stressed that exception requests apply only to highways which have partial or full access control.

8. EPA pointed out that the design noise levels are higher than the noise levels in EPA's *Ambient Noise Levels Document*. FHWA responded that its design noise levels were standards rather than recommended levels.

9. Several comments challenged the emphasis placed on the highway rather than the vehicle. FHWA replied that EPA was responsible for the vehicle.

10. Several comments requested the prescription of specific tests for determining adverse effect. FHWA replied that no such test had been developed.

11. Several comments requested that the noise insulation criteria be clarified. FHWA responded that every attempt had been made to do so.

12. Several comments involved construction noise. FHWA indicated that it was developing a state-of-the-art technical bulletin.

13. EPA suggested that  $L_{eg}$  and  $L_{10}$  be replaced by  $L_{eg}(24)$  or  $L_{dn}$ . FHWA replied

Although the explanatory materials suggest that the revised Subsection (i) Regulations embody only five significant changes from the original Subsection (i) Regulations,<sup>617</sup> this suggestion seriously understates both the number and the significance of the changes. The revised Subsection (i) Regulations are divided into thirteen sections. Three of these sections are totally new.<sup>618</sup> Two subsections in the original Subsection (i) Regulations have been elevated to section status.<sup>619</sup> All of the other sections contain changes ranging from minor to major.<sup>620</sup>

Section 772.9 governs applicability. The original Subsection (i) Regulations applied to "all highway projects planned or constructed . . . except projects unrelated to increased traffic noise levels."<sup>621</sup> The revised Subsection (i) Regulations apply with varying degrees to three different categories of federal-aid highway projects: Type IA projects, Type IB projects, and Type II projects.

Both Type IA and Type IB projects are "proposed Federal or Federal-aid highway project[s] for construction or reconstruction of a section of highway . . . and for which the highway location is approved after July 1, 1972, or the authorization to advertise for bids for the major grade and drain elements is given after July 1, 1976 . . . ."<sup>622</sup> There are two differences between Type IA and Type IB projects. Access is one distinguishing factor. A Type IA project "has either partial or full control of access."<sup>623</sup> In contrast, a Type IB project is one "on which the access is uncontrolled."<sup>624</sup> The other distinguishing factor involves exceptions to the applicable noise level standard.<sup>625</sup> Exceptions are permitted on Type IA projects,<sup>626</sup> they are not permitted on Type IB projects.<sup>627</sup>

---

that the effort required to obtain 24-hour assessments was not warranted.

41 Fed. Reg. 16,934-36 (1976).

617. *Id.* 16,934.

618. 23 C.F.R. §§ 772.3 (Noise Standards), .7 (Retroactivity), .23 (Construction Noise) (1979).

619. *Id.* § 772.17 (Policies for Coordination with Local Officials), .19 (Noise Abatement Measures for Undeveloped Land).

620. *See, e.g.*, notes 621-34 and accompanying text *infra*.

621. 23 C.F.R. § 772.6(b) (1973). Lighting, signing, landscaping, safety and bridge replacement are examples of "projects unrelated to increased traffic noise levels." *Id.*

622. *Id.* § 772.5(w), (x) (1979).

623. *Id.* § 772.5(w).

624. *Id.* § 772.5(x).

625. For a discussion of exceptions to noise level standards, see notes 679-86 and accompanying text *infra*.

626. 23 C.F.R. §§ 772.9(a), .15(b) (1979).

627. *Id.* § 772.9(b).

A Type II project is a "proposed Federal or Federal-aid highway project for noise abatement on an existing highway . . . which does not include construction or reconstruction of a highway section (or portion thereof)." <sup>628</sup> Type II projects are permissive rather than mandatory. <sup>629</sup> If a Type II project is proposed for federal-aid highway fund participation, the Type II project becomes subject to some but not all of the requirements of the Subsection (i) Regulations. <sup>630</sup>

In order for any project to be approved by FHWA, the state highway agency must prepare a noise study report <sup>631</sup> with which FHWA concurs, <sup>632</sup> and the project must have been developed in accordance with the Subsection (i) Regulations. <sup>633</sup> Type IA projects will not be approved unless "[n]oise abatement below . . . design noise levels . . ." <sup>634</sup> or "[p]artial noise abatement measures <sup>635</sup> are incorporated, where feasible, and exceptions to the [applicable] design noise level have been approved by FHWA." <sup>636</sup> Type IB projects are subject to a higher standard. They will not be approved unless "the noise abatement measures identified as feasible . . . have been incorporated in the plans and specifications for [the project]." <sup>637</sup>

The original Subsection (i) Regulations required compliance with the noise level standards unless location approval was obtained prior to July 1, 1972, and design approval was secured before July 1, 1974. <sup>638</sup> Under the interim regulations, <sup>639</sup> FHWA could approve noise abatement projects when a noise analysis had been performed, and when the state highway agency had determined that the noise abatement project should be assigned high priority, the noise abatement project would achieve a significant noise reduction, the benefits outweighed economic and environmental costs, and the noise abatement measures were for

---

628. *Id.* § 772.5(y).

629. *Id.* § 772.9(c).

630. *Id.*

631. For a discussion of noise study reports, see notes 652-56 and accompanying text *infra*.

632. 23 C.F.R. § 772.9(d)(1) (1979).

633. *Id.* § 772.9(d)(2).

634. *Id.* § 772.9(e)(1).

635. "Partial noise abatement measures" are "[m]easures taken to reduce the noise impact but not to a level below the design noise levels." *Id.* § 772.5(s).

636. *Id.* § 772.9(e)(2).

637. *Id.* § 772.9(f).

638. Compare 23 C.F.R. § 772.30 (1973) with *id.* § 772.6(c)(1).

639. See notes 605-07 *supra* and accompanying text.



noise-sensitive developed areas existing on January 1, 1973.<sup>640</sup> The revised Subsection (i) Regulations require compliance with the noise level standards for "all projects which receive authorization to advertise for the major grade and drain elements after July 1, 1976."<sup>641</sup>

Applicability, like all other elements of the revised Subsection (i) Regulations, is prospective. Actions taken prior to the effective date of the revised Subsection (i) Regulations—May 24, 1976—are governed by the original Subsection (i) Regulations, as amended by the interim regulations.<sup>642</sup>

Section 772.11 deals with analysis of traffic noise impact and abatement measures. The original Subsection (i) Regulations required that "noise [level] standards should be implemented at the earliest appropriate stage in the project development process."<sup>643</sup> In the revised Subsection (i) Regulations

the [state] highway agency shall determine and analyze expected traffic noise impacts [for Type IA and IB projects] and determine the overall benefits which can be achieved by noise abatement measures to mitigate these impacts, giving weight to any adverse social, economic, and environmental effects. The level of analysis may vary from simple calculations for rural and low volume highways to extensive analysis for high volume controlled access highways in urban areas.<sup>644</sup>

Each state highway agency is required to conduct a traffic noise analysis for each Type IA or IB project. This analysis consists of the following six steps: (1) identify affected existing activities or land uses,<sup>645</sup> (2) predict traffic noise levels for every alternative,<sup>646</sup> (3) measure noise levels for existing activities or developed land uses,<sup>647</sup> (4) compare predicted traffic noise levels with mea-

640. See 23 C.F.R. § 772.30(a) (1973).

641. FHPM 7-7-3, *supra* note 605 at 3.

642. 23 C.F.R. § 772.7 (1979).

643. *Id.* § 772.6(a) (1973).

644. *Id.* § 772.11(a) (1979).

645. *Id.* § 772.11(b)(1).

646. *Id.* § 772.11(b)(2).

Research conducted by the University of Alabama in Birmingham under a contract with the State of Alabama Highway Department indicates that the National Cooperative Highway Research Program Report 117 method of noise prediction is highly accurate. "The average difference between the measured L<sub>10</sub> value . . . and the predicted value . . . [in] 66 measurements was 1.91 dBA, the predicted value being the higher." Greere, *Prediction and Measurement of Highway Noise*, in PROCEEDINGS OF THE EPA—UNIVERSITY NOISE SEMINAR 136 (1976).

647. 23 C.F.R. § 772.11(b)(3) (1979).

sured noise levels,<sup>648</sup> (5) examine and evaluate alternative noise abatement measures for reducing noise impact,<sup>649</sup> and (6) identify for Type IA projects those lengths of highway and those individual land uses where an exception from the applicable design noise level will be sought because noise abatement measures appear to be either impractical or imprudent.<sup>650</sup> Steps (3) through (6) can be eliminated if activities or developed land uses will not be adversely affected by traffic noise.<sup>651</sup> After the traffic noise analysis has been completed, the state highway agency prepares a noise study report with which FHWA is asked to concur. This noise study report contains detailed noise analysis and evaluation information,<sup>652</sup> proposed noise abatement measures,<sup>653</sup> requests for exceptions to the applicable design noise level,<sup>654</sup> discussion of construction noise analysis information,<sup>655</sup> and discussion and documentation and coordination with local officials.<sup>656</sup>

The original Subsection (i) Regulations required a location stage traffic noise report<sup>657</sup> and an updated and expanded project design traffic noise report.<sup>658</sup> The revised Subsection (i) Regulations simplify the reporting requirements by requiring one noise study report. “[T]his noise study report may be in preparation throughout the project development process but shall be concluded prior to approval of the plans and specifications.”<sup>659</sup>

Table II-15<sup>660</sup> summarizes the noise level standards found in section 772.13.

---

648. *Id.* § 772.11(b)(4).

649. *Id.* § 772.11(b)(5).

650. *Id.* § 772.11(b)(6).

651. *Id.* § 772.11(b)(2).

652. *Id.* § 772.11(c)(1)(i).

653. *Id.* § 772.11(c)(1)(ii).

654. *Id.* § 772.11(c)(1)(iii).

655. *Id.* § 772.11(c)(1)(iv).

656. *Id.* § 772.11(c)(1)(v).

657. *Id.* § 772.7(b)(3) (1973).

658. *Id.* § 772.7(b)(4).

659. *Id.* § 772.11(c)(2) (1979).

660. Table II-15 is based on table 1 in 23 C.F.R. § 772.13 (1979).

TABLE II-15

Land-Use Category	$L_{eq}$ (in dB(A))	$L_{10}$ (in dB(A))	Description of Land Use
A	57	60	Land in which serenity and quiet are of extraordinary significance and serve an important public need <sup>661</sup>
B	67	70	Picnic areas, recreation areas, playgrounds, active sports areas, and parks, which are not included in Category A, and residences, motels, hotels, public meeting rooms, schools, churches, libraries, and hospitals
C	72	75	Developed lands, properties or activities not included in Categories A and B
D <sup>662</sup>			
E	52	55	Residences, motels, hotels, public meeting rooms, schools, churches, libraries, hospitals, and auditoriums

Section 772.13 noise level standards are defined in terms of land-use categories and design noise levels.<sup>663</sup> Design noise levels are prescribed for various land-use categories. The original Subsection (i) Regulations had a single noise level, expressed in  $L_{10}$ , for each land-use category.<sup>664</sup> An optional design noise level, expressed in  $L_{eq}$ , has been added in the revised Subsection (i) Regulations.<sup>665</sup>

The design noise levels for land-use categories A, B, and C

661. Land-Use Category A includes "amphitheaters, particular parks or portions of parks, open spaces, or historic districts." *Id.* § 772.13 (table 1).

662. Land-Use Category D is a category for undeveloped land. "Noise abatement measures are not required for lands which are undeveloped on the date of public knowledge of the proposed highway project . . ." *Id.* § 772.19(a). There are exceptions to this general rule. See notes 690-95 and accompanying text *infra*.

663. "Design noise levels" are "[t]he noise levels established . . . for various activities or land uses which represent the upper limit of acceptable traffic noise level conditions. These levels are used to determine the degree of impact of traffic noise on human activities." 23 C.F.R. § 772.5(d) (1979).

664. See *id.* § 772.3 (1973).

665. " $L_{eq}$ " is "[t]he equivalent steady state sound level which in a stated period of time would contain the same acoustic energy as the time-varying sound level during the same time period." *Id.* § 772.5(k) (1979).

are exterior noise levels. In the original Subsection (i) Regulations, exterior noise levels applied to "out-door areas which have regular human use and in which a lowered noise level would be of benefit."<sup>666</sup> The applicability of this term has been expanded in the revised Subsection (i) Regulations to include:

- (1) [t]hose undeveloped lands for which development is planned, designed, and programmed on the date of public knowledge of the highway project,<sup>667</sup>
- (2) [t]hose activities and land uses in existence on the date of public knowledge of the highway project,
- (3) [a]reas which have regular human use and in which a lowered noise level would be of benefit . . .<sup>668</sup> [and]
- (4) [t]hose places within the sphere of human activity . . . where activities actually occur . . .<sup>669</sup>

The design noise levels for land-use category E are interior noise levels. In the original Subsection (i) Regulations, interior noise levels applied to "indoor activities for those situations where no exterior noise sensitive land use or activity is identified."<sup>670</sup> The applicability of this term has been expanded in the revised Subsection (i) Regulations to include:

- (1)[i]ndoor activities for those parcels where no exterior noise sensitive land use or activity is identified [and]
- (2) [t]hose situations where the exterior activities on a tract are either remote from the highway or shielded in some manner so that the exterior activities will not be significantly affected by the noise, but the interior activities will.<sup>671</sup>

Interior noise levels can be calculated on the basis of field measurements.<sup>672</sup> Alternatively, interior noise levels can be com-

666. *Id.* § 772.3(c) (1973).

667. The "date of public knowledge of a proposed highway project" is "[t]he date that the highway agency officially notifies the public of the adoption of the location of a proposed highway project." *Id.* § 772.5(c) (1979).

668. The revised regulations state:

Such areas would not normally include service stations, junkyards, industrial areas, railroad yards, parking lots, storage yards, and the unused open space portions of other developments and facilities. Design noise levels should, however, be applied to those parks and recreational areas or portions thereof where serenity and quiet are considered essential even though such areas may not be subject to frequent human use.

*Id.* § 772.13(b)(3).

669. *Id.* § 772.13(b). "The values do not apply to an entire tract upon which an activity is based, but only to that portion on which such activity normally occurs." *Id.* § 772.13(b)(4).

670. *Id.* § 772.3(d) (1973).

671. *Id.* § 772.13(c) (1979).

672. *Id.* § 772.13(e).

puted by subtracting the noise reduction factors in Table II-16<sup>673</sup> from the exterior noise levels.

TABLE II-16

Building Type	Window condition <sup>674</sup>	Noise reduction factor (in dB(A))
All	Open	10
Light frame	Ordinary sash (closed)	20
	Storm windows	25
Masonry	Single glazed	25
	Double glazed	35

Design noise levels represent a balancing of the desirable with the achievable.<sup>675</sup> They are maximum values.<sup>676</sup> Each state highway agency has the responsibility to reduce predicted noise levels to design noise levels.<sup>677</sup> Since any significant reduction in either existing or predicted noise levels is beneficial, state highway agencies also have the responsibility to include partial noise abatement measures in the development of federal-aid highway projects, provided "they are consistent with overall social, economic, and environmental conditions."<sup>678</sup>

Section 772.15 discusses exceptions. The original Subsection (i) Regulations acknowledged that "there may be sections of highways where it would be impracticable to apply noise abatement measures."<sup>679</sup> Noise abatement measures were deemed to be "impracticable" if physical conditions prevented their use, the costs incurred in abating noise were high in relationship to the benefits obtained, or a conflict existed between the noise abatement measures and other important values.<sup>680</sup> If noise abatement measures were impracticable, FHWA was authorized to grant exceptions to the applicable design noise levels.

673. Table II-16 is based on a table in 23 C.F.R. § 772.13(e)(1) (1979).

674. The Subsection (i) Regulations provide that "windows shall be considered open unless there is a firm knowledge that the windows are in fact kept closed almost every day of the year." *Id.* § 772.13(e)(2).

675. *Id.* § 772.13(a).

676. *Id.*

677. *Id.*

678. *Id.*

679. *Id.* § 772.4(a) (1973).

680. *Id.*

The revised Subsection (i) Regulations continue to authorize exceptions to the applicable design noise levels, but the scope of and basis for this authorization has changed. Exceptions used to be granted to all categories of projects. They now can be granted only to Type IA projects.<sup>681</sup> Obviously, this change narrows the scope of Section 772.15. Exceptions used to be based on impracticability. They now are based on a judgment that "the adverse social, economic, and environmental effects of the noise abatement measures are considered to exceed the abatement benefits."<sup>682</sup> The nature of this change is more difficult to assess. Probably the change, whatever its dimensions may be, is more a matter of semantics than a matter of substance.

Exceptions to Type IA projects are conditioned on the submission of a report to FHWA by the state highway agency requesting an exception. In its report, the state highway agency (1) identifies noise sensitive activities along the section of highway that are subject to existing noise levels or will be subject to predicted noise levels in excess of design noise levels, (2) examines the benefits and detriments of partial noise abatement measures, (3) weighs overall benefits which can be achieved by noise abatement measures against any adverse effects and conflicting values,<sup>683</sup> and (4) recommends "partial noise abatement measures determined to have benefits consistent with adverse effects."<sup>684</sup>

Exceptions are normally approved if the predicted noise level is less than the existing noise level for the activity or land use in question.<sup>685</sup> All approvals, however, are conditioned on "a showing that all reasonable options for noise reduction . . . have been explored and that the partial noise abatement measures recommended provide the greatest attainable noise reductions consistent with the overall public interest."<sup>686</sup>

Section 772.17 outlines how state highway agencies should coordinate their activities with local governments and apportions responsibilities. State highway agencies are responsible for assuring compatibility between the location and design of federal-aid highways and existing and planned land uses.<sup>687</sup> Local govern-

---

681. *Id.* § 772.15 (1979).

682. *Id.* § 772.15(a).

683. "A principal factor in this weighing shall be the concern for public health, public welfare, and the quality of life. These decisions must ultimately be based upon case-by-case determination." *Id.* § 772.15(b)(3).

684. *Id.* § 772.15(b)(4).

685. *Id.* § 772.15(d).

686. *Id.* § 772.15(c).

687. *Id.* § 772.17.

ments are responsible for controlling land development and zoning.<sup>688</sup> In order to promote compatibility, state highway agencies are urged to cooperate with local governments by furnishing them with (1) "approximate generalized future noise levels . . . for both developed and undeveloped lands or properties in the immediate vicinity of the [Type IA or Type IB project]," (2) "information that may be useful . . . to protect future land development from being incompatible with anticipated highway noise levels," and (3) FHWA policy regarding land-use development.<sup>689</sup>

Noise abatement measures for undeveloped lands are the subject of section 772.19. Section 772.19, like section 772.17, was a subsection in the original Subsection (i) Regulations but has now been elevated to section status in the revised Subsection (i) Regulations. Noise abatement measures, as a general rule, are not required for land which is undeveloped on the date of public knowledge of the proposed highway project.<sup>690</sup> There are exceptions to this rule. Noise abatement measures should be employed where a development was planned, designed, and programmed before the highway project, but the development has been temporarily delayed.<sup>691</sup> They should be employed where a development and a highway project are planned, designed, and programmed contemporaneously.<sup>692</sup> They should be employed where a development occurs between the date of public knowledge of a proposed Type IA or Type IB project and actual construction.<sup>693</sup> They should be employed where the probability of a development occurring within a few years is very high and a strong case<sup>694</sup> can be made in favor of providing noise abatement measures as a part of a Type IA or Type IB project.<sup>695</sup>

Section 772.21 articulates federal funding policy for federal-

---

688. *Id.* Local governments face a variety of pressures: "Sometimes the local officials who control land use, planning, and zoning are not aware of the potential noise [accompanying development]. In other instances they are subject to local pressures which are difficult, if not impossible to resist." PUBLIC HEARINGS II, *supra* note 260, at 95 (statement of Harter M. Rupert, FHWA).

689. 23 C.F.R. § 772.17 (1979).

690. *Id.* § 772.19(a).

691. *Id.* § 772.19(b)(1).

692. *Id.* § 772.19(b)(2).

693. *Id.* § 772.19(c)(1).

694. A "strong case" must be made "based on consideration of need, expected long-term benefits to the public interest, and the difficulty and increased cost of later incorporating abatement measures into either the highway or the development." *Id.* § 772.19(c)(2).

695. *Id.*

aid highways. Even a cursory comparison of the revised Subsection (i) Regulations with the original Subsection (i) Regulations reveals that federal funding policy has been expanded. The purpose of this expansion is "to provide greater flexibility . . . in considering, on a case-by-case basis, proposals to participate in extraordinary noise abatement measures where the noise impacts are especially severe and where more conventional abatement measures are unacceptable for social, economic, and environmental or engineering design reasons."<sup>696</sup> Extraordinary measures include but are not limited to "acquisition of a severely impacted property, relocation of a dwelling or other structure, and noise insulation for private structures."<sup>697</sup>

In order for federal funds to be made available, several requirements must be satisfied. They include: "(1) [a] traffic noise impact has been identified, (2) [t]he noise abatement measures will reduce the noise impact, and (3) [t]he overall noise abatement benefits . . . outweigh the overall adverse social, economic, and environmental effects of the noise abatement measures."<sup>698</sup>

Section 772.21 distinguishes between Type I and Type II projects. Federal funding for Type I projects is quite generous. The following noise abatement measures are listed as appropriate for incorporation into such projects:

- (1) Traffic management measures,<sup>699</sup>
- (2) Alterations of horizontal and vertical alignments,
- (3) Acquisition of property rights . . . for installation or construction of noise abatement barrier or devices,
- (4) Installation or construction of noise barriers or devices . . . whether within or outside the highway right-of-way, and
- (5) Acquisition of real property or interests therein . . . to serve as a buffer zone to preempt development which would be adversely impacted by traffic noise and for other noise abatement measures . . . .<sup>700</sup>

In contrast to Type I projects, federal funding for Type II projects is more limited. The list of appropriate noise abatement measures is shorter. Measures (2) and (5) applicable to Type I projects are

696. 41 Fed. Reg. 16,934 (1976).

697. *Id.*

698. 23 C.F.R. § 772.21(a) (1979).

699. Traffic management measures include but are not limited to "traffic control devices and signing for prohibition of certain vehicle types, time use restrictions for certain vehicle types, modified speed limits, and exclusive lane designations." *Id.* § 772.21(b)(1).

700. *Id.* § 772.21(b)(2).



not applicable to Type II projects.<sup>701</sup> In addition, "noise abatement measures will not normally be approved for those activities and land uses which come into existence after [May 24, 1976]."<sup>702</sup>

The revised Subsection (i) Regulations also provide for case-by-case consideration of noise insulation and "other abatement measures." Noise insulation may be considered where "compelling reasons" exist.<sup>703</sup> Its use, however, is limited to public use or nonprofit institutional structures such as schools, churches, libraries, hospitals, and auditoriums.<sup>704</sup> Other abatement measures may be considered where "[e]specially severe traffic noise impacts exist or are expected"<sup>705</sup> and "[conventional noise] abatement measures . . . are physically infeasible or economically unreasonable."<sup>706</sup>

The original Subsection (i) Regulations contained no provisions on construction noise. Section 772.23 in the revised Subsection (i) Regulations corrects that oversight and requires state highway agencies to take the following general steps:

- [1] Identify land uses or activities which may be affected by noise from construction of the highway.<sup>707</sup>
- [2] Determine the measures which are needed in the contract plans and specification to minimize or eliminate adverse construction noise impacts to the community.<sup>708</sup>
- [3] Incorporate the needed abatement measures in the contract plans and specifications.<sup>709</sup>

## 2. Enforcement of the FAHWA

FHWA administers the provisions of the FAHWA. Noise is not the responsibility of one particular office. Rather, this responsibility is shared by four different offices in three of the six sections of FHWA. The Office of Environmental Policy within the

701. *Id.* § 772.21(c)(3).

702. *Id.* § 772.21(c)(2).

703. *Id.* § 772.21(d).

704. *Id.* Noise insulation, particularly in older buildings, is "enormously expensive." See PUBLIC HEARINGS IV, *supra* note 6, at 19. (Statement of Wes Uhlman, Mayor of Seattle, Washington).

705. 23 C.F.R. § 772.21(e)(1) (1979).

706. *Id.* § 772.21(e)(2).

707. This step is performed during the project development studies. *Id.* § 772.23(a).

708. "This determination shall include a weighing of the benefits achieved and the overall adverse social, economic, and environmental effects of the abatement measures." *Id.* § 772.23(b).

709. *Id.* § 772.23(c).

Right-of-Way and Environmental Section is composed of six individuals. One senior specialist devotes all of his time to noise; the remaining five individuals divide their time between air and noise but devote at least fifty percent of their time to noise.<sup>710</sup> Two civil engineers and a technician in the Office of Engineering within the Engineering and Traffic Operations Section provide assistance to state highway agencies when they design noise abatement measures.<sup>711</sup>

Two physicists in the Office of Research within the Research and Development Section monitor and manage noise research programs.<sup>712</sup> In the same section, a civil engineer in the Office of Development implements noise programs and generally acts as a troubleshooter.<sup>713</sup> The Office of Development performs a variety of functions. For example, this office produced a film entitled "The Audible Landscape" and has published several technical manuals.<sup>714</sup>

Region 15 is the Demonstration Projects Division of FHWA. A civil engineer and two technicians assigned to this division are involved in a noise demonstration project.<sup>715</sup> The purpose of this project, which travels from state to state, is to demonstrate existing noise measurement techniques.

In addition to these personnel, an average of one individual in each FHWA regional and divisional office<sup>716</sup> is concerned with noise. As a result, one FHWA official estimates that seventy person-years are devoted annually to noise by FHWA.<sup>717</sup> This same FHWA official estimates that FHWA's noise grants amount to approximately \$30 million a year and that FHWA's noise research amounts to less than \$1 million a year.<sup>718</sup>

---

710. Telephone conversation with Harter M. Rupert, Office of Environmental Policy, FHWA (Dec. 14, 1979).

711. *Id.*

712. *Id.*

713. *Id.*

714. *Id.* The information in the film mentioned in the text is also available. See FEDERAL HIGHWAY ADMIN., THE AUDIBLE LANDSCAPE: A MANUAL FOR HIGHWAY NOISE AND LAND USE 1 (1974).

715. Telephone conversation with Harter M. Rupert, Office of Environmental Policy, FHWA (Dec. 14, 1979).

716. FHWA maintains a divisional office in each of the fifty states.

717. Telephone conversation with Harter M. Rupert, Office of Environmental Policy, FHWA (Dec. 14, 1979).

718. *Id.*



## SECTION III

### REGULATION OF TRAFFIC NOISE IN NEW YORK STATE

While New York State has no comprehensive noise law comparable to either the federal government's Noise Control Act<sup>1</sup> or the New York City Noise Control Code,<sup>2</sup> its laws do contain numerous provisions dealing with noise.<sup>3</sup> Traffic noise is dealt with specifically by three provisions of the New York Vehicle and Traffic Law. These three provisions are currently the primary means by which the state seeks to control traffic noise. In addition, the New York Environmental Conservation Law deals with the problem of noise pollution, and a Noise Bureau has been created within the Department of Environmental Conservation.

#### A. *Vehicle and Traffic Law*

##### 1. *Noise provisions*

a. *Vehicle muffler provisions.* Section 375(31) of the New York Vehicle and Traffic Law (V & TL) is a muffler provision for motor vehicles:

Every motor vehicle, operated or driven upon the highways of the state, shall at all times be equipped with an adequate muffler and exhaust system in constant operation and properly maintained to prevent any excessive or unusual noise and no such muffler or exhaust system shall be equipped with a cutout, bypass, or similar device. No person shall modify the muffler or exhaust system of a motor vehicle in a manner which will amplify or increase the noise emitted by the motor or exhaust system of such vehicle above that emitted by the muffler or exhaust system originally installed on the vehicle and such original muffler and exhaust system shall comply with all the requirements of this section.<sup>4</sup>

---

1. 42 U.S.C. §§ 4901-4918 (1976); 49 U.S.C. § 1431 (1976).  
2. New York, N.Y., Local Law No. 57, Noise Control Code (Oct. 4, 1972).  
3. In addition to N.Y. VEH. & TRAF. LAW §§ 375, 381, 386 (McKinney 1970 & Cum. Supp. 1978-1979), which will be discussed in detail, notes 4-50 and accompanying text *infra*, the laws of New York State contain the following noise provisions: N.Y. GEN. BUS. LAW §§ 7, 14 (McKinney Cum. Supp. 1978-1979) (disturbing the peace on Sunday, processions and parades on Sunday); N.Y. MULT. DWELL. LAW § 84 (McKinney 1974) (construction standards); N.Y. NAV. LAW §§ 44 to 44-c (McKinney 1941 & Cum. Supp. 1978-1979) (vessel mufflers); N.Y. PENAL LAW §§ 215.50, 215.55, 240.20-.21 (McKinney 1975) (criminal contempt, unreasonable noise as disorderly conduct, disruption or disturbance of religious services); N.Y. TOWN LAW § 130(11) (McKinney 1965) (noise abatement ordinances); N.Y. WORK. COMP. LAW §§ 49-aa to 49-gg (McKinney 1965) (occupational loss of hearing).

4. N.Y. VEH. & TRAF. LAW § 375(31) (McKinney Cum. Supp. 1978-1979).

Section 375(31) defines a muffler as "a device consisting of a series of chambers or baffle plates, or other mechanical design for the purpose of receiving exhaust gas from an internal combustion engine, and effective in reducing noise." Most states have a muffler provision similar to section 375(31).<sup>5</sup>

Section 15(1) of the V & TL,<sup>6</sup> the predecessor of section 375(31), prohibited "unnecessary noise." Section 15(1) was struck down in *People v. Zanchelli*<sup>7</sup> on the ground that "unnecessary noise" was too vague to constitute a sufficient definition of criminal conduct.<sup>8</sup> The court also suggested that section 15(1) might have violated the equal protection clause because the standard was susceptible to two interpretations—one for trucks, another for cars.<sup>9</sup> Section 15(1) was also found to be unconstitutionally vague in *People v. Sisson*.<sup>10</sup> Between the defendant's arrest and the court's decision in *Sisson*, the defective section had been replaced by section 15(31) of the V & TL.<sup>11</sup> Section 15(31) substituted "excessive or unusual noise" for "unnecessary noise" as the standard defining a violation of the muffler provision. Although section 15(31) had no bearing on the outcome of *Sisson*, the court took the opportunity to comment on the new section, observing that it "corrects the error found in [section 15(1)] by setting up standards and definitions covering prevention of excessive noise emanating from mufflers."<sup>12</sup>

In 1959 section 15(31) was renumbered as section 375(31).<sup>13</sup> The validity of section 375(31) was first tested in *People v. Byron*,<sup>14</sup> now considered the leading case on traffic noise in New York State. Its standard of "excessive or unusual noise" was challenged on the same void-for-vagueness and equal protection

5. *E.g.*, ARIZ. REV. STAT. ANN. § 28-955 (1976 & Cum. Supp. 1978-1979); CAL. VEH. CODE § 27150 (West Cum. Supp. 1979); CONN. GEN. STAT. § 14-80(c) (1977); ILL. REV. STAT. ch. 95 ½, § 12-602 (1973); LA. REV. STAT. ANN. § 32:352 (West 1963); MASS. GEN. LAWS ANN. ch. 90, § 16 (West Cum. Supp. 1979); N.J. STAT. ANN. § 39:3-70 (West 1973); TENN. CODE ANN. § 59-902 (1968); UTAH CODE ANN. § 41-6-147(a) (Cum. Supp. 1979); VA. CODE § 46.1-301 (1974); WASH. REV. CODE ANN. § 46.37.390 (Cum. Supp. 1979).

6. Vehicle and Traffic Law, ch. 54, § 15(1), 1929 N.Y. Laws 63 (repealed 1959).

7. 8 Misc. 2d 1069, 169 N.Y.S.2d 197 (Columbia County Ct. 1957).

8. *Id.* at 1071, 169 N.Y.S.2d at 199-200. For an excellent discussion of the void-for-vagueness doctrine, see Note, *The Void-for-Vagueness Doctrine in the Supreme Court*, 109 U. PA. L. REV. 67 (1960).

9. 8 Misc. 2d at 1071, 169 N.Y.S.2d at 199.

10. 12 Misc. 2d 18, 176 N.Y.S.2d 785 (Schenectady County Ct. 1958).

11. Act of Apr. 11, 1958, ch. 630, 1958 N.Y. Laws 1425 (current version at N.Y. VEH. & TRAF. LAW § 375(31) (McKinney Cum. Supp. 1978-1979)).

12. 12 Misc. 2d at 19, 176 N.Y.S.2d at 786.

13. Vehicle and Traffic Law, ch. 775, §§ 375(31), 2014, 1959 N.Y. Laws 1855.

14. 17 N.Y.2d 64, 215 N.E.2d 345, 268 N.Y.S.2d 24 (1966).

grounds on which the standard of "unnecessary noise" had been challenged. The court considered and rejected the equal protection argument. According to the court, section 375(31) is a motor vehicle statute rather than a noise statute. What the statute requires is that each driver have and maintain an adequate muffler. This duty falls equally on all drivers. As a result, the fact that a truck with an adequate muffler emits more noise than a car with an adequate muffler is not vital.<sup>15</sup> The court also considered and rejected the void-for-vagueness argument. "What is usual noise in the operation of a car has become common knowledge and anything in excess of that is excessive or unusual and any ordinary motorist should have no difficulty in ascertaining whether or not excessive or unusual noise accompanied the operation of his vehicle."<sup>16</sup>

Section 381 of the V & TL is a muffler provision for motorcycles:

1. (a) Every motorcycle, driven upon the public highways of this state . . . shall have a suitable muffler or device to prevent unnecessary noise from exhaust gases, and the use of so-called "cut-outs" is prohibited.

. . . .  
11. No person shall operate a motorcycle on any highway (1) which is not equipped with a muffler to prevent excessive or unusual noise; (2) equipped with a muffler from which the baffle plates, screens or other original internal parts have been removed or altered; (3) equipped with an exhaust system which has been modified in a manner which will amplify or increase the noise emitted by the motor of such vehicle above that emitted by the exhaust system originally installed on the vehicle.<sup>17</sup>

Section 381(1)(a) prohibits "unnecessary noise"; section 381(11) prohibits "excessive or unusual noise." The "unnecessary noise" standard in section 381(1)(a) was challenged in *People v. Meyer*.<sup>18</sup> Noting that "unnecessary noise" had been held unconstitutionally vague in the context of section 15(1),<sup>19</sup> the court indicated that "serious doubts exist as to the validity of [section 381(1)]."<sup>20</sup>

15. *Id.* at 68, 215 N.E.2d at 348, 268 N.Y.S.2d at 28.

16. *Id.* at 67, 215 N.E.2d at 347, 268 N.Y.S.2d at 27.

17. N.Y. VEH. & TRAF. LAW § 381(1)(a), (11) (McKinney 1970 & Cum. Supp. 1978-1979).

18. 63 Misc. 2d 580, 313 N.Y.S.2d 93 (Ct. Spec. Sess. 1970).

19. See *People v. Zanchelli*, 8 Misc. 2d 1069, 169 N.Y.S.2d 197 (Columbia County Ct. 1957); notes 6-9 and accompanying text *supra*.

20. 63 Misc. 2d at 581, 313 N.Y.S.2d at 93-94.

The court, however, elected not to decide the constitutional issue and instead dismissed the charges because the prosecution merely showed that the motorcycle made noise. According to the court, such a showing was "insufficient," since the prosecution "must show either a decibel rating above that allowed by law under section 386, . . . or that the vehicle in question made noise in excess of what was usual for vehicles of its class . . . ."<sup>21</sup> This language in *Meyer* has discouraged subsequent use of section 381(1)(a). Since *Meyer*, section 381(11), which has an excessive or unusual noise standard similar to section 375(31), has been used to control motorcycle muffler noise.<sup>22</sup>

*b. Noise emission standards provision.* In 1965 New York State enacted section 386 of the V & TL.<sup>23</sup> Section 386 is a noise emission standards provision. Unlike muffler provisions, which are common, noise emission standards provisions are quite rare at the state level.<sup>24</sup>

---

21. *Id.*, 313 N.Y.S.2d at 94 (emphasis in original). The noise emission standard under the version of § 386 that existed when *Meyer* was decided was 88 dB(A). The noise emission standard is now 86 dB(A). N.Y. VEH. & TRAF. LAW § 386 (McKinney Cum. Supp. 1978-1979).

22. See Table III-2, note 51 and accompanying text *infra*. Citations in Table III-2 are either § 375(31) or § 381(11) muffler violations. Hence, there were no citations for § 381(1) muffler violations for the period, 1969-1977.

23. Act of July 21, 1965, ch. 1053, § 1, 1965 N.Y. Laws 2722 (current version at N.Y. VEH. & TRAF. LAW § 386 (McKinney Cum. Supp. 1978-1979)).

24. *E.g.*, CAL. VEH. CODE §§ 27200-27207 (West Cum. Supp. 1979); CONN. GEN. STAT. § 14-80a (1977).

The permissible noise levels under the California noise emission standards depend on the type of motor vehicle and the year of manufacture.

1. Motorcycles:

Manufactured after 1969 but before 1973	88 dB(A)
Manufactured after 1972 but before 1975	86 dB(A)
Manufactured after 1974 but before 1981	83 dB(A)
Manufactured after 1980 but before 1986	80 dB(A)
Manufactured after 1985 but before 1990	75 dB(A)
Manufactured after 1989	70 dB(A)

2. Snowmobiles:

Manufactured after 1972	82 dB(A)
-------------------------	----------

Section 386 owes its existence to the determined efforts of a group of citizens in Westchester County, New York, who wanted to reduce truck noise on turnpikes in residential areas of that county.<sup>25</sup> They organized themselves as the Thruway Noise Abatement Committee and successfully lobbied in favor of the passage of section 386. As originally enacted, section 386 contained the following provisions:

1. No motor vehicle, other than an authorized emergency vehicle or a vehicle moving under special permit, which makes or creates excessive or unusual noise, shall operate upon a public highway.

---

3. Motor vehicles with a gross weight rating of 6000 pounds or more:

Manufactured after 1967 but before 1973	88 dB(A)
--	----------

Manufactured after 1972 but before 1975	86 dB(A)
--	----------

Manufactured after 1974 but before 1978	83 dB(A)
--	----------

4. Motor vehicles with a gross vehicle weight between 6000 and 8500 pounds:

Manufactured after 1977	80 dB(A)
-------------------------	----------

5. Motor vehicles exceeding 8500 pounds gross vehicle weight:

Manufactured after 1977 but before 1982	83 dB(A)
--	----------

Manufactured after 1981	80 dB(A)
-------------------------	----------

6. Any other motor vehicle:

Manufactured after 1967 but before 1973	86 dB(A)
--	----------

Manufactured after 1972 but before 1975	84 dB(A)
--	----------

Manufactured after 1974	80 dB(A)
-------------------------	----------

The Connecticut noise emission standards apply to "any device suitable for the conveyance, drawing or other transportation of persons or property . . . except those propelled or drawn by human power or those used exclusively upon tracks." CONN. GEN. STAT. § 14-1(56) (1977).

The permissible noise levels under the Connecticut noise emission standards are as follows:

1973-1974	90 dB(A)
1975-1976	88 dB(A)
1977 and thereafter	86 dB(A)

In addition, § 14-80a(d) provides that the permissible noise level for "vehicles sold or offered for sale in the state" shall be 85 dB(A) in 1975 and thereafter.

25. See Note, *Urban Noise Control*, 4 COLUM. J.L. & Soc. PROB. 105, 111 (1968).



2. A motor vehicle which produces a sound level of eighty-eight decibels or more on the "A" scale shall be deemed to make or create excessive or unusual noise.

(a) Sound pressure levels in decibels shall be measured on the A scale of a standard sound level meter having characteristics defined by American Standards Association specification S 1.4-1961 "General Purpose Sound Level Meter." Measurements of sound pressure level shall be made in accordance with applicable measurement practices outlined in the Society of Automotive Engineers Standards J672 "Measurement of Truck and Bus Noise" as approved January, nineteen hundred fifty-seven. The microphone shall be placed at a distance of fifty feet plus or minus two feet from the center of the lane in which the vehicle is traveling.

(b) Measurements of sound pressure level shall be made at speeds of less than thirty-five miles per hour.

(c) No arrest shall be made in cases where the noise limit is exceeded by less than a two decibel tolerance.<sup>26</sup>

In 1972 the United States enacted the Noise Control Act (NCA). Sections 6 and 18 of the NCA provide for federal noise emission standards. Pursuant to that authorization, the Environmental Protection Agency (EPA) published noise emission standards for interstate motor carriers (Motor Carrier Regulations/Motor Carrier Compliance Regulations),<sup>27</sup> published noise emission standards for new medium and heavy-duty trucks (New Truck Regulations),<sup>28</sup> and has published proposed noise emission standards for new garbage trucks, new buses, and new motorcycles.<sup>29</sup>

As a general rule, federal noise emission standards preempt state noise emission standards. The question thus posed is whether and to what extent the New Truck Regulations and the Motor Carrier Regulations/Motor Carrier Compliance Regulations preempt section 386. Although the noise emission standards found in section 386 might be interpreted as noise emission standards for new motor vehicles, a more plausible interpretation is

26. Act of July 21, 1965, ch. 1053, § 1, 1965 N.Y. Laws 2722.

27. Motor Carriers Engaged in Interstate Commerce, 39 Fed. Reg. 38,208 (1974) (codified at 40 C.F.R. §§ 202.10-.23 (1978)); Compliance with Interstate Motor Carrier Noise Emission Standards, 40 Fed. Reg. 42,432 (1975) (codified at 49 C.F.R. §§ 325.1-.93 (1978)).

28. Transportation Equipment Noise Emission Controls, 41 Fed. Reg. 15,538 (1976) (codified at 40 C.F.R. §§ 205.1-.59 (1978)).

29. 42 Fed. Reg. 43,226 (1977) (new garbage trucks); 42 Fed. Reg. 45,776 (1977) (new buses); 43 Fed. Reg. 10,822 (1978) (new motorcycles).

that they are noise emission standards for in-use motor vehicles. The latter interpretation finds some support in the language of the original section 386: "No motor vehicle . . . which makes or creates excessive or unusual noise, shall operate upon a public highway."<sup>30</sup> If this interpretation is correct, section 386 is preempted by the Motor Carrier Regulations/Motor Carrier Compliance Regulations.

New York State revised section 386 in 1976.<sup>31</sup> In justifying this action, the legislature summarized its findings as follows:

Motor vehicles are an indispensable segment of the transportation system of the state of New York. However, the attendant sound emissions form a major component of the prevailing environmental noise levels. Motor vehicle generated noise adversely affects the general health and welfare of the citizens throughout the state. . . . In view of the available and economically feasible techniques for motor vehicle noise control, continuation of current vehicular sound levels without abatement would be an unreasonable burden on the citizens of the state and their environment. Failure to impose reasonable and effective limitations on vehicular noise levels at this time would also result in further growth of public opposition to the orderly development and utilization of motor vehicle transportation.<sup>32</sup>

These legislative findings are as significant for what they do not mention as for what they do. No mention is made of federal regulations. No mention is made of the fact that the original section 386 would have been preempted had section 386 not been revised. No mention is made of the fact that section 386 is being revised so as to bring its provisions into conformity with the provisions of the Motor Carrier Regulations/Motor Carrier Compliance Regulations.

Except for an emergency vehicles provision found in both the original and the revised section 386, the revised section 386 is substantially different.<sup>33</sup> Revised section 386 applies to "the total sound level<sup>34</sup> emitted from a motor vehicle or combination of

---

30. Act of July 21, 1965, ch. 1053, § 1, 1965 N.Y. Laws 2722.

31. Act of July 20, 1976, ch. 543, § 2, 1976 N.Y. Laws 1225 (McKinney 1976).

32. *Id.* § 1.

33. Compare N.Y. VEH. & TRAF. LAW § 386 (McKinney Cum. Supp. 1978-1979) with Act of July 21, 1965, ch. 1053, § 1, 1965 N.Y. Laws 2722.

34. Revised § 386 defines "A-weighted sound level" as "the sound pressure level measured by the use of an instrument with the metering characteristics and A-weighting frequency response prescribed for sound level meters." N.Y. VEH. & TRAF. LAW § 386(1)(a) (McKinney Cum. Supp. 1978-1979).

vehicles,"<sup>35</sup> while the original section 386 was silent on this point. Revised section 386 also applies only to motor vehicles or combinations of vehicles<sup>36</sup> with a gross weight in excess of 10,000 pounds,<sup>37</sup> while the original section contained no such limitation.

The methods of testing for violations of emission standards and the standards themselves are substantially changed in revised section 386. Revised section 386 contains two testing procedures, a highway test<sup>38</sup> and a stationary test.<sup>39</sup> Under the highway testing procedure, the noise levels that are permissible at 50 feet/15.2 meters from the center of the lane in which the motor vehicle is traveling are set out in Table III-1.

TABLE III-1

Test	Permissible Noise Levels (in dB(A))	
	Speed limit of 35 mph/56 kmph or less	Speed limit of more than 35 mph/56 kmph
Highway	86	90

A noise level of 88 dB(A) is permissible at 50 feet/15.2 meters from "the longitudinal centerline of the vehicle, when the engine . . . is accelerated from idle with a wide open throttle to governed speed with the . . . transmission in neutral and clutch engaged," under the stationary testing procedure.<sup>40</sup> Compared to the revised section 386, the original section 386 was relatively simple. It provided that "[a] motor vehicle which produces a sound level of [88 dB(A) when traveling 35 mph/56 kmph or less] shall be deemed to make or create excessive or unusual noise."<sup>41</sup>

The revised section 386 authorizes the Commissioner of Environmental Conservation<sup>42</sup> to take certain enforcement measures. He is to issue regulations "establishing the measurement procedures and instrumentation to be utilized in . . . [enforcing

35. *Id.* § 386(2).

36. Revised § 386 defines "[c]ombination of vehicles" as "any device consisting of a motor vehicle and one or more trailers drawn by such motor vehicle." *Id.* § 386(1)(b).

37. *Id.* § 386(3).

38. *See id.* § 386(3)(a).

39. *Id.* § 386(3)(b).

40. *Id.*

41. Act of July 21, 1965, ch. 1053, § 1, 1965 N.Y. Laws 2722.

42. For a discussion regarding the Commissioner of Environmental Conservation, see note 75 and accompanying text *infra*.

section 386].”<sup>43</sup> As a guide in the formulation of these regulations, the legislature required the commissioner to consider “recognized scientific and professional [measurement] standards.”<sup>44</sup> The legislature also suggested that the procedures “allow, to the extent feasible, motor vehicle sound measurements to be accomplished in reasonably confined areas” and “provide for sound measurement at distances other than fifty feet and in the vicinity of sound reflecting surfaces.”<sup>45</sup> No analogous provision is found in the Motor Carrier Regulations/Motor Carrier Compliance Regulations. On the contrary, those regulations specify that the sound measurements take place on an open site and do not permit measurements closer than 35 feet/10.7 meters.<sup>46</sup>

When the commissioner issued the authorized regulations on April 1, 1977,<sup>47</sup> he declined to follow the suggestion that measurement be made in confined areas or in the vicinity of sound-reflecting surfaces. The commissioner’s reluctance to incorporate those items into the authorized regulations is not surprising, particularly when one considers the inclination of federal officials to make the Motor Carrier Regulations/Motor Carrier Compliance Regulations as specific as possible.<sup>48</sup> Such specificity enlarges the realm of federal preemption and prevents state and local officials from diverging from the federal regulations.

The commissioner is also required to report at two-year intervals to the Governor and the legislature. One purpose of the report is to describe “the current state of the art of motor vehicle sound level limitations.”<sup>49</sup> Another purpose is to recommend changes as necessary.<sup>50</sup>

## 2. *Enforcement of the Vehicle and Traffic Law*

Sections 375(31), 381(11), and 386 are enforced by the New York State Police. Table III-2<sup>51</sup> shows by year the total number

---

43. N.Y. VEH. & TRAF. LAW § 386(4) (McKinney Cum. Supp. 1978-1979).

44. *Id.* § 386(4)(b).

45. *Id.* § 386(4)(a). By way of illustration, the revised § 386 defines “confined areas” as “residential areas of urban cities.” *Id.*

46. See Section II, notes 122-24, 185-86 *supra*.

47. OFFICIAL COMP. OF THE CODE, RULES AND REGULATIONS OF THE STATE OF N.Y. tit. 6, ch. IV, subch. E, pt. 450-54 (1977).

48. For a discussion of the federal perspective, see Section II, notes 172-74 and accompanying text *supra*.

49. N.Y. VEH. & TRAF. LAW § 386(7) (McKinney Cum. Supp. 1978-1979).

50. *Id.*

51. Statistics for Table III-2 were compiled by the New York State Police and supplied to the author. Letter from Maj. N.F. Gianguialano, New York State Police, Albany, N.Y., to the author (July 31, 1974).

of citations for violations of these three provisions, the number of citations for muffler violations (sections 375(31) (motor vehicles) and 381(11) (motorcycles)), and the number of citations for noise emission standards violations (section 386).

TABLE III-2

Year	Total Citations	Muffler Violation Citations	Noise Emission Standards Violation Citations
1969	13,045	13,037	8
1970	9,878	9,865	13
1971	9,739	9,727	12
1972	11,632	11,610	22
1973	11,353	11,319	34
1974	10,803	10,770	33
1975	10,094	10,075	19
1976	7,964	7,952	12
1977	7,260	7,256	4
1978	9,567	9,562	5

As can be seen from Table III-2, citations for muffler violations have always accounted for the overwhelming majority of total citations, ranging from a high of 99.9% in 1969 and 1977 to a low of 99.6% in 1974. Citations for noise emission standards violations have always been miniscule in comparison to citations for muffler violations. Based on a one-year (1977) sample, citations for noise emission standards violations dropped sharply after the enactment of the revised section 386. While the revision may have contributed to the drop in citations, there were also other factors at play.<sup>52</sup>

The current expectation is that total citations in general and citations for noise emission standards violations in particular will continue to decline, conceivably dropping to zero.<sup>53</sup> The reason for

52. New York State experienced a budgetary "crunch." This crunch forced the New York State Police to analyze their priorities with the greatest care and to eliminate or curtail their activities except in the area of crime prevention.

53. Telephone conversation with Sgt. Salisbury, New York State Police, Albany, N.Y. (Apr. 10, 1978).

this decline is that sections 375(31), 381(11), and 386 are enforced by the New York State Police. Enforcement by the state police is a problem for at least two reasons. First, the average police officer lacks equipment and training. Sound level meters, for example, are not considered to be standard equipment. Indeed, the New York State Police have a total of only five such meters.<sup>54</sup> The average police officer receives no training in noise abatement or in the operation of sound level meters. Such training is absolutely essential in enforcing section 386 since such enforcement requires setting up and operating expensive and fairly complex equipment.<sup>55</sup> Second, the New York State Police, like most police, view their major mission as crime prevention and assign it first priority. Noise abatement is and probably should be given a lower priority. As a result, problems arise even when there are adequate resources to hire personnel and purchase needed equipment. In periods of austerity, such as New York State is now experiencing, the problems become massive and may result in a halt in enforcement.<sup>56</sup>

One possible solution to this enforcement problem is the creation of an environmental police force. New York City already has a small environmental police force,<sup>57</sup> and New York State is in the process of creating such a police force to enforce the provisions of the Environmental Conservation Law.<sup>58</sup> In the meantime, a partial solution could be achieved if enforcement responsibilities were shared by the police and some other entity. Enforcement of the muffler provisions, for example, could be the shared responsibility of the police and the service station operators who conduct the yearly motor vehicle inspection.<sup>59</sup> However, a muffler check

---

54. *Id.*

55. The New York State Police have never had such a training program. The Noise Bureau within the Department of Environmental Conservation has developed a 16-hour training program and is currently developing a self-study training program. See note 117 and accompanying text *infra*.

56. The New York State Police practically never enforce § 386. See Table III-2, note 51 and accompanying text *supra*.

57. For a discussion of New York City's environmental police force, see Section IV, notes 83-85 and accompanying text *infra*.

58. See notes 115-19 and accompanying text *infra*.

59. If enforcement responsibilities were shared, the most likely division of responsibilities would be one in which police would issue notices of violation to motor vehicles they reasonably suspect violate the standard of "excessive or unusual noise" and service station operators would conduct necessary tests to determine whether there was in fact a violation. Such a division of responsibilities presupposes the existence of guidelines to assist service station operators in determining whether there is a violation.

Service station operators would also conduct a yearly inspection of each motor vehicle

during the yearly motor vehicle inspection would necessitate a change in the current philosophy that views the muffler provisions as noise rather than safety laws.<sup>60</sup>

Enforcement is not the only problem. Another problem is the questionable constitutional validity of certain noise abatement provisions. For example, the doubts expressed in *People v. Meyer*<sup>61</sup> as to the constitutionality of the "unreasonable noise" standard found in section 381(1)(a) certainly has undermined its effectiveness.<sup>62</sup> These doubts probably could be resolved by substituting the "excessive or unusual noise" standard found in sections 375(31) and 381(11) for the "unnecessary noise" standard. Hopefully, the legislature will make this change.

New York's experience with section 386 illustrates two additional problems. One is the relationship between federal and state noise emission standards.<sup>63</sup> State noise emission standards must be identical to federal noise emission standards. As viewed from the state perspective, this requirement is annoying when the standards or procedures differ and becomes a serious infringement of state efforts to control noise when the federal standards or procedures are less restrictive. No such serious infringement has occurred in New York State because the noise emission standards adopted in the Motor Carrier Regulations/Motor Carrier Compliance Regulations were more restrictive than the noise emission standard in original section 386.<sup>64</sup>

The other problem is the infrequent and limited application of section 386. The fact that only 157 traffic arrests were made for violations of section 386 during the nine-year period, 1969-1977, is some indication of its infrequent application.<sup>65</sup> Applica-

---

registered in the state to determine whether it violated the standard of "excessive or unusual noise."

60. The requirements for the state's yearly motor vehicle inspection are specified by the Department of Motor Vehicles. A muffler inspection is not one of the current requirements.

61. 63 Misc. 2d 580, 313 N.Y.S.2d 93 (Ct. Spec. Sess. 1970).

62. *Id.* at 581, 313 N.Y.S.2d at 94. The court in *Meyer* avoided the issue of the questionable constitutional validity of § 381(1)(a) by basing its decision on insufficient evidence. If the evidence had been sufficient, the court probably would have held § 381(1)(a) unconstitutionally vague.

63. Neither the Federal Republic of Germany nor the United States has successfully resolved the problem of federal preemption. For a discussion of this subject from the federal perspective, see generally Section II *supra*; Section V *infra*.

64. The noise emission standard set by the Motor Carrier Compliance Regulations is 86 dB(A). 49 C.F.R. § 325.7 (1978). New York State's standard under § 386 was 88 dB(A) but has since been revised downward to 86 dB(A). N.Y. VEH. & TRAF. LAW § 386 (McKinney Cum. Supp. 1978-1979).

65. See Table III-2, note 51 and accompanying text *supra*.

tion is also limited in geographic terms. In 1974 section 386 was enforced on "the New York State Thruway at the Buffalo/Niagara area and the New England Section which runs within New York City, north to the Connecticut State border."<sup>66</sup> The New York State Police practically never enforce section 386 at the present time.<sup>67</sup> They do participate in joint road checks with the Bureau of Motor Carrier Safety, the federal entity that enforces the Motor Carrier Compliance Regulations.<sup>68</sup> Approximately thirty such road checks are conducted in New York State each year. Most of these road checks take place in central New York State.<sup>69</sup>

## B. Environmental Conservation Law

### 1. Noise provisions

a. *Articles 1, 3, 5, and 7.* When Governor Nelson Rockefeller approved the original Environmental Conservation Law (ECL) on April 22, 1970,<sup>70</sup> he characterized the law as "a bold new State commitment to our environment."<sup>71</sup> The ECL was subsequently repealed and recodified.<sup>72</sup> The legislature explained the purpose of this change as follows:

The purpose of this act is to enact a recodified environmental conservation law . . . of New York State . . . but without any substantive changes. The purpose of this act is further declared to be the continuation of the department of environmental conservation, and of all laws, rules, regulations, orders, proceedings and other matters presently administered by that department.<sup>73</sup>

---

66. Letter from Maj. N.F. Gianguialano, New York State Police, Albany, N.Y., to the author (July 31, 1974). According to Maj. Gianguialano, this geographic limitation was the result of the number of complaints received. He indicated that the New York State Police "respond to, and investigate complaints received in other parts of the State and make arrests when warranted." *Id.*

67. See Table III-1, note 51 and accompanying text *supra*.

68. For a discussion of the activities of the Bureau of Motor Carrier Safety, see Section II, notes 594-612 and accompanying text *supra*.

69. Telephone conversation with Sgt. Salisbury, New York State Police, Albany, N.Y. (Apr. 10, 1978).

70. When he approved the original version of the Environmental Conservation Law, Governor Rockefeller remarked that he was "particularly pleased to give [his] approval to [the] measure on Earth Day—a day on which people throughout the State and Nation are expressing their personal commitment to protecting our environment." New York Governor's Memorandum (April 22, 1970).

71. *Id.*

72. Environmental Conservation Law, ch. 664, 1972 N.Y. Laws 2242 (codified at N.Y. ENVIR. CONSERV. LAW §§ 1-0101 to 71-3503 (McKinney 1973 & Cum. Supp. 1978-1979)) (repealing Environmental Conservation Law, ch. 140, 1970 N.Y. Laws 866).

73. *Id.* § 1.



Article 1 of the recodified ECL contains the following declaration of environmental policy:

The quality of our environment is fundamental to our concern for the quality of life. It is hereby declared to be the policy of the State of New York to conserve, improve and protect its . . . environment . . . in order to enhance the health, safety and welfare of the people of the state and their overall economic and social well being.<sup>74</sup>

Article 3 establishes a Department of Environmental Conservation. Section 3-0103 provides that the Commissioner of Environmental Conservation shall be the head of the department. The functions, duties, and powers of the department and the commissioner are enumerated in section 3-0301. The commissioner's responsibilities include the power to "[p]rovide for prevention and abatement of . . . noise."<sup>75</sup>

Article 5 establishes a State Environmental Board. The board is composed of various members, including the Commissioner of Environmental Conservation, who acts as chairman.<sup>76</sup> Some of the board's duties are to assist the commissioner in his review and appraisal of programs and activities,<sup>77</sup> to provide information to the Council of Environmental Advisors and review its proposals,<sup>78</sup> and to serve as a forum for the exchange of views.<sup>79</sup> One of the board's principal functions is to approve each environmental standard, criterion, rule, or regulation.<sup>80</sup>

74. N.Y. ENVIR. CONSERV. LAW § 1-0101(1) (McKinney 1973).

75. *Id.* § 3-0301(1)(i).

76. *Id.* § 5-0101 (McKinney Cum. Supp. 1978-1979). In addition to the Commissioner of Environmental Conservation, the State Environmental Board is composed of the Commissioner of Health, who acts as vice-chairman, the Commissioners of Agriculture and Markets, Commerce, Transportation, Parks and Recreation, the Secretary of State, the Chairman of the Public Service Commission, the Industrial Commissioner, the Commissioner of the State Energy Office and members appointed by the Governor with the advice and consent of the senate. One of the members appointed by the Governor is to represent conservationists and should be familiar with matters pertaining to natural resource utilization; one, who is employed by a manufacturer or public utility, is to represent industry; one is to represent agriculture; the remaining members are to be drawn from the fields of public health, natural science, urban studies, or other fields relating to ecology or natural resource management. None can be an officer or employee of any state department or agency. *Id.*

77. *Id.* § 5-0107(1)(a) (McKinney 1973). Programs and activities are to be reviewed and appraised in terms of the declaration of environmental policy found in § 1-0101(1). See note 74 and accompanying text *supra*.

78. N.Y. ENVIR. CONSERV. LAW § 5-0107(1)(c) (McKinney 1973).

79. *Id.* § 5-0107(1)(d).

80. *Id.* § 5-0107(2) (McKinney Cum. Supp. 1978-1979). The board must either ap-

Article 7 establishes a Council of Environmental Advisors. The council consists of seven members who are to advise the Governor on matters of environmental policy.<sup>81</sup> In fulfilling this responsibility, the council advises the Governor on a "comprehensive environmental management policy for the state,"<sup>82</sup> provides an overview "on matters affecting the environment,"<sup>83</sup> develops guidelines to govern the interrelationship between "environmental equality, economic development, and the growing population,"<sup>84</sup> and studies and reports on environmental trends.<sup>85</sup>

*b. Air Pollution Control Act.* Article 19 of the ECL is the Air Pollution Control Act (APCA). The APCA defines noise as an "[a]ir contaminant."<sup>86</sup> In order to prevent and control air contamination, the Department of Environmental Conservation has the power under section 19-0301 to issue codes, rules, and regulations,<sup>87</sup> to divide the state into areas and prescribe different standards for the different areas,<sup>88</sup> to adopt standards for air contaminant emission control systems,<sup>89</sup> and to hold public hearings, conduct investigations, compel attendance and receive pertinent proof.<sup>90</sup> The department has the responsibility to develop a comprehensive control and abatement plan,<sup>91</sup> to encourage voluntary

prove or deny a proposed standard, criterion, rule, or regulation within 60 days after receipt. Approval requires an affirmative vote of a majority of the members of the board. After the board has acted on a proposed standard, criterion, rule, or regulation, the board is to inform the commissioner of its action in writing. If the board fails to act within the 60-day period, the standard, criterion, rule, or regulation is deemed to have been approved.

81. *Id.* § 7-0101 (McKinney 1973). The seven members of the Council of Environmental Advisors must be (1) private citizens, (2) representative of a broad range of interests and disciplines, and (3) responsive to the needs and concerns of the present and future generations. The Governor appoints the members of the council with the advice and consent of the state senate and designates one of their number to serve as chairman.

82. *Id.* § 7-0107(1)(a).

83. *Id.* § 7-0107(1)(b).

84. *Id.* § 7-0107(1)(c).

85. *Id.* § 7-0107(1)(d).

86. *Id.* § 19-0107(2).

87. *Id.* § 19-0301(1)(a).

88. *Id.* § 19-0301(1)(b) (McKinney Cum. Supp. 1978-1979). The department can prescribe for each area, among other things, (1) the degree of air contamination that will be permitted and (2) the extent to which any air contamination source may emit air contaminants. *Id.*

89. *Id.* § 19-0301(1)(c) (McKinney 1973). These standards must comply with the Vehicle and Traffic Law.

90. *Id.* § 19-0301(1)(d).

91. *Id.* § 19-0301(2)(a).

cooperation,<sup>92</sup> to assist public and private groups in formulating prevention and abatement plans<sup>93</sup> and to cooperate with international, national, interstate, and state agencies.<sup>94</sup> The promulgation of codes, rules, and regulations by the department requires a public hearing "within the area of the state concerned."<sup>95</sup>

Pursuant to the provisions of sections 19-0301 and 19-0303, a Noise Bureau was created within the department. The Noise Bureau began its operations with high expectations. Its goal was to develop control programs for aircraft and airports, air conditioners, construction, emergency warning devices, motorboats, motor vehicles, motor vehicle racetracks, off-road recreational vehicles, railroads, sound source sites, and snowmobiles.<sup>96</sup> Each source was to have its own regulations.

Proposed Regulations for the Prevention and Control of Environmental Noise Pollution were issued in August 1973.<sup>97</sup> The title of the proposed regulations was a misnomer. In fact, the proposed regulations were "sound source sites" regulations.<sup>98</sup> The proposed regulations specifically exempted from their provisions "[s]ounds created by the tires and motor when propelling a motor vehicle that is registered to operate on public highways. This exception does not apply to auxiliary equipment on such vehicles or while such vehicles are under repair or test."<sup>99</sup> A document entitled "Prevention and Control of Environmental Noise Pollution, Explanation of Noise Control Regulations for Sound Source Sites" accompanied the proposed regulations.<sup>100</sup> The ex-

92. *Id.* § 19-0301(2)(b). "[A]ll persons" should cooperate in controlling air contamination.

93. *Id.* § 19-0301(2)(c).

94. *Id.* § 19-0301(2)(d).

95. *Id.* § 19-0303(1) (McKinney Cum. Supp. 1978-1979).

96. See N.Y. Dep't of Environmental Conservation, Prevention and Control of Environmental Noise Pollution, Explanation of Noise Control Regulations for Sound Source Sites 17 (Aug. 1973) (Exhibit 8) [hereinafter cited as Explanation Document].

97. N.Y. Dep't of Environmental Conservation, Proposed Regulations for the Prevention and Control of Environmental Noise Pollution 1-6 (Aug. 1973).

98. A "[s]ound source site" is

any fixed geographic location that consists of all contiguous land and water areas under the ownership or control of a person. The sound source site includes all individual sources of sound that are located on such site, stationary, movable and mobile, except as provided by Parts 003 and 006. Examples of sound source sites are factories, power plants, air conditioners on nonresidential property, motor vehicle repair shops, railroad yards, and commercial establishments with amplified music outside.

*Id.* pt. 001.1 (pp) (emphasis omitted).

99. *Id.* pt. 006.4(a)(2).

100. Explanation Document, *supra* note 96.

planation document described the relationship between the proposed regulations and the V & TL as follows:

New York State Vehicle and Traffic Law regulates the noise from motor vehicles operating on public highways. The proposed regulation does not apply to the sound created by the tires and motor when propelling a motor vehicle registered to operate on public roads. Under other conditions, the sounds created by motor vehicles are included in the sources that would comprise a sound source site.<sup>101</sup>

Since the motor and tires are the principal sources of motor vehicle noise,<sup>102</sup> other sounds are relatively insignificant.<sup>103</sup>

The high expectations of the Noise Bureau have not been realized. Not only have the proposed regulations never been issued in final form, but the planned regulations for motor vehicles have never even been issued in proposed form. The Noise Bureau, however, has issued two regulations which were not originally anticipated: one for solid waste management facilities,<sup>104</sup> and a second for noise from heavy motor vehicles.<sup>105</sup> The Heavy Motor Vehicle Regulations are authorized by revised section 386 of the V & TL.<sup>106</sup> They are practically identical to the federal Motor Carrier Compliance Regulations.<sup>107</sup> As a result of these developments, the Noise Bureau makes no attempt to regulate traffic noise under the ECL at the present time, but relies instead on the V & TL and the Heavy Motor Vehicle Regulations.

## 2. Enforcement of the ECL

The Noise Bureau is a bureau within the Division of Air Resources.<sup>108</sup> In 1974 its staff consisted of a principal acoustical

---

101. *Id.* at 10.

102. See U.S. ENVIRONMENTAL PROTECTION AGENCY, TRANSPORTATION NOISE AND NOISE FROM EQUIPMENT POWERED BY INTERNAL COMBUSTION ENGINES 100-10 (1971).

103. Refrigerator, garbage, and cement trucks are an exception. Noise from auxiliary equipment is frequently the main source of annoyance in these three types of trucks.

104. OFFICIAL COMP. OF THE CODES, RULES AND REGULATIONS OF THE STATE OF N.Y. tit. 6, ch. IV, subch. B, pt. 360 (1977).

105. *Id.* subch. E, pt. 450.

106. See N.Y. VEH. & TRAF. LAW § 386(4) (McKinney Cum. Supp. 1978-1979).

107. Telephone conversation with Dr. William Webster, Noise Bureau (May 5, 1978). Compare 49 C.F.R. §§ 202.10-23 (1978) with OFFICIAL COMP. OF THE CODES, RULES AND REGULATIONS OF THE STATE OF N.Y. tit. 6, ch. IV, subch. E, pt. 450 (1977). A question raised by New York City's experience is what impact discrepancies will have on enforcement of the Heavy Motor Vehicles Regulations. See Section IV, notes 57-60 and accompanying text *infra*.

108. The Division of Air Resources is one of several program divisions within the Department of Environmental Conservation.

engineer, two senior acoustical engineers, a senior engineering technician (acoustical), an electronic equipment mechanic, and a senior stenographer.<sup>109</sup> Its staff today consists of a principal acoustical engineer and a senior acoustical engineer.<sup>110</sup>

Table III-3<sup>111</sup> shows by fiscal year<sup>112</sup> the Noise Bureau's budget since its creation.

TABLE III-3

Fiscal Year	Budgeted Amount	Percentage Decrease
1973-1974	\$148,000	—
1974-1975	135,000	9
1975-1976	127,000	6
1976-1977	89,000	30
1977-1978	50,000	44
1978-1979	50,000	0

As can be seen, the Noise Bureau's budget declined constantly until fiscal year 1977-1978 when the budgeted amount stabilized at \$50,000. Obviously, the Noise Bureau has been affected by New York State's "budgetary crunch." The decline in the Noise Bureau's allocation may also reflect a decline in the state's interest in noise.

There are nine regional enforcement units under the ECL.<sup>113</sup> No funds, however, have ever been allocated for the operation of regional noise offices.<sup>114</sup> Consequently, the anticipated regional plan of enforcement has never been implemented. There are, however, enforcement personnel. These enforcement personnel are designated either as environmental conservation officers<sup>115</sup> or public health engineers.<sup>116</sup> New York State has 254 environmental

109. Letter from Dr. Fred Haag, Director, Noise Bureau, to the author (Apr. 15, 1974).

110. Telephone conversation with Dr. Fred Haag, Director, Noise Bureau (Apr. 10, 1978).

111. Table III-3 is based on information provided to the author by Dr. Fred Haag, Director, Noise Bureau. *Id.*

112. New York State's fiscal year runs from April 1 to March 31.

113. Telephone conversation with Dr. Fred Haag, Director, Noise Bureau (Apr. 10, 1978).

114. *Id.*

115. Today's environmental conservation officers were yesterday's game wardens.

116. Public health engineers are joint state/county employees. According to Dr. Fred

conservation officers. Thirty-one of those environmental conservation officers recently completed a sixteen-hour course on noise abatement.<sup>117</sup> Unfortunately, they have no equipment.<sup>118</sup> Public health engineers are active in Rockland County, but they are enforcing that county's sanitary code rather than state regulations.<sup>119</sup>

Even if the regional noise offices began to function and the Noise Bureau issued the once-planned motor vehicle regulations, the ECL may not be particularly effective in controlling traffic noise. This gloomy conclusion is based largely on the fact that the ECL defines noise as an air contaminant and uses the APCA to control noise. The APCA, which was drafted in terms of stationary rather than moving sources, is ill suited for this task. One problem is its procedure. The commissioner must make an investigation, issue a notice of violation, and hold a public hearing before he can issue a final order or a final determination.<sup>120</sup> This procedure assumes that the source is a stationary source.<sup>121</sup> The APCA's fine schedule is also a problem. The minimum fine is \$250.<sup>122</sup> Based on New York City's experience,<sup>123</sup> many judges will be reluctant to impose a fine of this size on a motorist who is a first offender.

These problems will persist as long as the APCA remains unchanged or until a new article is added to the ECL that deals exclusively with noise. The ideal solution would be for the legislature to enact a new article. At a minimum, certain provisions of the APCA should be amended so that the ECL can effectively control noise.

---

Haag, Director, Noise Bureau, the primary responsibility for enforcing the ECL will be borne by these public health engineers. Telephone conversation with Dr. Fred Haag, Noise Bureau (Apr. 5, 1974).

117. Telephone conversation with Dr. William Webster, Noise Bureau (May 5, 1978). The 16-hour course was given during two working days of instruction. More than 400 officers from 115 different state agencies have expressed interest in this training program. Consequently the Noise Bureau is developing a self-study program.

118. *Id.*

119. Telephone conversation with Dr. Fred Haag, Noise Bureau (Apr. 10, 1978).

120. See N.Y. ENVIR. CONSERV. LAW §§ 19-0503, -0505, -0507 (McKinney Cum. Supp. 1978-1979).

121. All procedural steps require time. Time is not a significant factor when the source is stationary. However, time is a significant factor if the source is mobile and can leave the jurisdiction before the procedural steps have been completed.

122. See N.Y. ENVIR. CONSERV. LAW § 71-2103(1) (McKinney Cum. Supp. 1978-1979).

123. See Section IV, note 101 and accompanying text *infra*.



## SECTION IV

### REGULATION OF TRAFFIC NOISE IN NEW YORK CITY

It would be difficult to select one night out of three hundred and sixty-five, during which the entire population of New York are permitted to rest in peace. . . . Surely a city kept in a fever of excitement through the day ought to be permitted to rest in tranquility at night.<sup>1</sup>

#### A. Overview of Attempts to Control Noise in New York City

##### 1. Noise regulation committees

The foregoing editorial, written over a century ago, suggests that noise is not a new problem for residents of New York City. Indeed, New York City residents have become sufficiently concerned about noise in this century to create committees on four separate occasions to study the problem. The first committee, which issued reports from 1907-1913, was the Society for the Suppression of Unnecessary Noise.<sup>2</sup> The Noise Abatement Commission, established by the Department of Health in 1929, published a report in 1930 entitled *City Noise*. This report led to the enactment of many of the noise laws effective in New York City between 1930 and 1970,<sup>3</sup> and was widely cited throughout the United States and in Europe.<sup>4</sup>

The third committee, the Committee for a Quiet City,<sup>5</sup> concluded that New York City's first objective should be to eliminate

---

1. N.Y. Times, Sept. 13, 1859, at 4, col. 4. This editorial was prompted by the practice of the New York City Fire Department of responding to all fire alarms, regardless of the size of the fire or the time of day, in the same manner. The "dismal tolling of bells" and "shouts and bellowings" which accompanied the response to any fire were a "nuisance." *Id.*

2. See NEW YORK CITY MAYOR'S TASK FORCE ON NOISE CONTROL, TOWARD A QUIETER CITY 33 (1970) [hereinafter cited as TASK FORCE REPORT].

3. *Id.*

4. *Id.* The Noise Abatement Commission conducted a survey in 1929 to determine the major perceived sources of noise. According to the survey, the ten major sources were: trucks, automobile horns, radios, elevated trains, automobile brakes and cut-outs, garbage collections, street cars, fire department sirens, noisy parties and entertainment, and milk and ice deliveries. See COMMITTEE FOR A QUIET CITY, FINAL REPORT AND RECOMMENDATIONS 14 (1956) [hereinafter cited as FINAL REPORT].

5. FINAL REPORT, *supra* note 4, at 10. This committee also conducted a noise survey in 1956 similar to the Noise Abatement Commission's survey. According to the 1956 survey, the ten major noise sources were: refuse collection, hornhonking, acceleration of motors, radio and TV sets, aircraft noise, unmuffled exhausts, street repairs, sound trucks, construction riveting, and doormen's whistles. *Id.* at 13.



unnecessary hornhonking.<sup>6</sup> A comprehensive program to achieve this objective culminated in "Q-Day"<sup>7</sup> on March 15, 1956. Q-Day was preceded by a three-month period during which the media publicized an antihornhonking law and a two-week period during which the police issued warnings to drivers who honked their horns unnecessarily. The committee issued its *Final Report and Recommendations* after Q-Day. According to the report, "[Q-Day] was instantly and dramatically successful. Comparative decibel readings at the busiest intersections showed an average decrease in the noise level of 75% . . . ."<sup>8</sup> The committee, therefore, concluded that "needless hornblowing can be drastically reduced and could eventually be virtually eliminated when an intensive educational campaign is combined with . . . periodic . . . enforcement . . . ."<sup>9</sup>

In the late 1960's, a Task Force on Noise Control was appointed by Mayor John Lindsay. Members of the task force were "[f]irmly convinced that noise is not an intractable problem."<sup>10</sup> Consequently, they established the following objectives for their study:

1. To define the problem.
2. To identify the chief sources of noise in the City.
3. To investigate the various means and resources by which noise may be reduced.
4. To establish acoustical criteria, taking into consideration the needs and requirements of the city, for its present and future residents.
5. To test whether principles and methods, learned in the course of the investigation, could be actually applied . . . ."<sup>11</sup>

After studying the problem, the task force in 1970 published

---

6. See *id.* at 10. The committee selected the elimination of unnecessary hornhonking as New York City's first objective for a variety of reasons:

- (a) with two million automotive vehicles on the streets of New York, incessant and senseless hornblowing was the most obvious needless noise
- (b) the experience of Paris and Rome served as a precedent to prove that hornblowing could be drastically diminished
- (c) an existing law . . . gave "teeth" to this campaign by providing penalties for violations.

*Id.*

7. The "Q" stands for "quiet."

8. FINAL REPORT, *supra* note 4, at 11. Hornhonking has received periodic attention since 1956. See, e.g., notes 91, 101 and accompanying text *infra*.

9. FINAL REPORT, *supra* note 4, at 11.

10. TASK FORCE REPORT, *supra* note 2, at 5.

11. *Id.*

*Toward a Quieter City*, containing general recommendations and the reports of various subcommittees.<sup>12</sup>

The task force recommended that “[a] creative partnership . . . be established between public agencies and private enterprise.”<sup>13</sup> Since the contribution of the public sector would be critical in this creative partnership, the task force suggested that New York City provide leadership<sup>14</sup> and exercise all of its existing powers to control noise.<sup>15</sup> The task force also recommended that either New York City’s Environmental Protection Administration (NYCEPA), or a special department of noise control established within it, determine acoustical values<sup>16</sup> and regulate and control noise.<sup>17</sup> Regarding the noise control program, the task force recommended the inclusion of noise as a factor in the planning pro-

---

12. In addition to these recommendations, which will be discussed in detail, notes 13-25 and accompanying text *infra*, the following subcommittee reports are found in the task force’s report: Medical Subcommittee Report, Building Subcommittee Report, Legal Subcommittee Report, Technical Subcommittee Report, and Public Relations Subcommittee Report.

13. *Id.* at 6.

14. According to the task force, the “success or failure of a noise abatement program will be determined by the City Administration.” *Id.* The report cautioned that leadership by the administration “must not be shortlived; rather it must be sustained and purposeful in order to overcome temporary setbacks or waning expression of interest.” *Id.*

15. The task force concluded that one of the major problems faced by New York City was achieving effective noise control with its existing powers. The city administration was advised to “press for realistic noise criteria and encourage sustained noise controls.” *Id.* at 7. Unfortunately, the administration lacked “crucial enforcement power over some vital services performed by such agencies as the Transit Authority, the Port Authority and all Federal agencies.” *Id.* In order to compensate for this lack of enforcement power, the task force felt that the city would not only have to exercise its existing noise abatement powers but would also have to use its powers of persuasion and example. *Id.*

16. The task force recommended certain acoustical criteria:

(1) Noises above the hearing conservation criterion of 85 dB(A) on a continuous basis are injurious and should not be permitted.

(2) Noises interfering with the normal level of speech — above 52 dB(A) — should be reduced as soon as possible.

(3) A desirable limit for noise in wholly residential areas is 40 dB(A) in daytime hours and 30 dB(A) during nighttime hours.

*Id.* at 7.

17. The task force proposed that NYCEPA or a special department of noise control within it carry out a five-point program: (1) act as a liaison between city government and the business community; (2) act as a liaison among branches of city government, independent authorities, and federal agencies; (3) undertake a comprehensive noise survey; (4) maintain continuous supervision of noise conditions; and (5) establish a research program to monitor technological advances in noise control. *Id.* at 7-9.

The law which created NYCEPA failed to delineate NYCEPA’s authority or jurisdiction in the area of noise control. Consequently, the task force suggested that the law be amended to include regulatory provisions for noise similar to the existing air pollution provisions. *Id.* at 6. NYCEPA was subsequently abolished. See note 82 *infra*.

cess,<sup>18</sup> the prevention of new noise sources,<sup>19</sup> and the adoption of effective acoustical design by business.<sup>20</sup>

Several specific recommendations supplemented the general recommendations. The task force concluded that the permissible noise level set by section 386 of New York State's Vehicle and Traffic Law,<sup>21</sup> intended primarily to regulate truck noise on the open road, was "completely unrealistic for conditions in [New York] City" and urged New York City to lobby for an amendment to section 386.<sup>22</sup> In the event that the state legislature refused to amend section 386, the task force suggested that New York City adopt its own higher standards.<sup>23</sup> The task force also concluded that the ordinance creating the New York City Environmental Protection Administration<sup>24</sup> was defective because it contained no grant of authority to adopt and amend rules regulating or prohibiting harmful or objectionable noise. Consequently, the task force urged that the law be amended to confer such authority on NYCEPA.<sup>25</sup>

## 2. Regulation prior to 1972

At the time the task force was making its study, New York City had several noise laws. Its primary noise law was section 435-5.0 of the Administrative Code.<sup>26</sup> Section 435-5.0 addressed itself,

---

18. The task force proposed that noise be recognized as "an essential element of basic City planning and development." TASK FORCE REPORT, *supra* note 2, at 6.

19. Preventing new noise sources is easier than abating well-established noise sources. Consequently, the task force endorsed a program in which prevention would be given first priority. *Id.* at 6.

20. Effective acoustical design benefits business and the consumer. The consumer appreciates the quieter product; business profits from better sales. According to the task force, quieter refrigerators, automobiles, and outboard motors have resulted in increased sales. *Id.*

21. The permissible noise level under § 386 of New York State's Vehicle and Traffic Law was 88 dB(A) at the time the task force made its study. For a discussion of § 386, see Section III, notes 23-50 and accompanying text *supra*.

22. See TASK FORCE REPORT, *supra* note 2, at 9-10.

23. *Id.* at 10. The state legislature did not revise § 386 until 1976. Its procrastination probably contributed to the enactment of New York City's Noise Control Code in 1972. The code contains a lower permissible noise level for motor vehicles than did the original § 386. See notes 45-47 and accompanying text *infra*.

24. NEW YORK CITY, N.Y., ADMIN. CODE ch. 57, § 1400 (1970).

25. TASK FORCE REPORT, *supra* note 2, at 9.

26. NEW YORK CITY, N.Y., ADMIN. CODE ch. 18, § 435-5.0 (1970) (repealed 1972).

In addition to § 435-5.0 of the Administrative Code, two other provisions should be mentioned. Section 435-6.0 of the Administrative Code regulated sound devices. Section 151 of the Traffic Regulations limited the use of motor vehicle horns.

Mention should also be made of the fact that New York City was the first American city to incorporate noise performance standards into its building code. New York City,

in part, to the definition of prohibited noise: "[T]he creation of any unreasonably loud, disturbing and unnecessary noise is prohibited. Noise of such character, intensity and duration as to be detrimental to the life or health of any individual is prohibited."<sup>27</sup> Section 435-5.0 then went on to identify specific noises which were prohibited because they were disturbing and unnecessary.<sup>28</sup>

Section 435-5.0 was typical of the noise laws that existed at the local level in the United States prior to the 1970's. Most of the laws were directed at noise in general. In this respect section 435-5.0 represented an improvement because of its enumeration of twelve specific acts as violating the prohibition of unreasonably loud, disturbing, and unnecessary noise. Section 435-5.0(b) also stated that this list of acts was illustrative rather than exhaustive.<sup>29</sup> Most of the noise laws, moreover, used a subjective rather than an objective standard to define noise. In this respect

---

N.Y., Local Law No. 96 (Oct. 4, 1972). These provisions are now codified in NEW YORK CITY, N.Y., ADMIN. CODE ch. 26, §§ 1208.1-.3 (1970). Since these sections cannot be used to regulate traffic noise—they establish transmission sound limits for walls, noise emission standards for air conditioning, heating, and mechanical equipment, and impact noise levels for floors and ceilings—no discussion of them will be found in this Section. There are, however, numerous articles that deal with subart. 1208. See, e.g. Grad & Hack, *Noise Control in the Urban Environment*, 1972 URB. L. ANN. 3; Comment, *Toward the Comprehensive Abatement of Noise Pollution: Recent Federal and New York City Noise Control Legislation*, 4 ECOLOGY L.Q. 109 (1974); Note, *A Model Ordinance to Control Urban Noise Through Zoning Performance Standards*, 8 HARV. J. LEGIS. 608 (1971).

27. NEW YORK CITY, N.Y., ADMIN. CODE ch. 18, § 435-5.0(a) (1970) (repealed 1972).

28. The noises thus identified included:

1. The sounding of any horn or signal device on any automobile, motorcycle, bus, street car or other vehicle . . . except as a danger signal . . . ; the creation by means of any such signal device of any unreasonably loud or or harsh sound or the sounding of any such device for an unnecessary and unreasonable period of time.

4. The use of any automobile, motorcycle, street car or vehicle so out of repair, so loaded or in such manner as to create loud and unnecessary grating, grinding, rattling or other noise.

6. The discharge into the open air of any exhaust of any . . . motor vehicle . . . engine except through a muffler or other device which will effectively prevent loud or explosive noises therefrom.

8. The creation of any excessive noise on any street adjacent to any school, institution of learning or court while the same is in session, or adjacent to any hospital, which unreasonably interferes with the workings of such institution

9. The creation of a loud and excessive noise in connection with loading or unloading of any vehicle . . . .

*Id.* § 435-5.0(b).

29. Section 4355.0 prohibited, *inter alia*, "[t]he following acts, among others." *Id.* (emphasis added).

section 435-5.0 was typical because noise was defined as "any unreasonably loud, disturbing and unnecessary" sound. Subjective standards are difficult to enforce. What is loud, disturbing, and unnecessary to one person may be perfectly acceptable to another person. Subjective standards also invite constitutional attack on void-for-vagueness grounds because "loud, disturbing and unnecessary" is too vague to constitute a sufficient definition of criminal conduct.

The inadequacies of section 435-5.0 and its companion ordinances were evident by the 1970's. At that time, a variety of options were available to New York City that are not available today. Federal legislation did not exist; state legislation did not preempt local legislation. Today, American cities face federal preemption of noise emission standards, and many face state preemption of other aspects of noise control.<sup>30</sup> New York City's experience, therefore, illustrates the possibilities that existed before federal and state governments began to regulate traffic noise, as well as the accommodations local governments have had to or will have to make because of such regulation.

### B. *The Noise Control Code of 1972*

On September 12, 1972, the New York City Council passed a comprehensive noise law, the Noise Control Code.<sup>31</sup> Mayor John Lindsay signed the code on October 4, 1972. The code thus became New York City's primary noise law.

#### 1. *Code provisions*

Four of the code's eight articles are addressed, either directly or indirectly, to traffic noise.<sup>32</sup> The code could have defined noise

---

30. For a discussion of the options available to local government since the enactment by Congress of the Noise Control Act, see Comment, *Noise Abatement at the Municipal Level*, 7 U.S.F. L. REV. 479 (1973).

The situation is even more severe in the Federal Republic of Germany where cities are faced not only with federal preemption of noise emission standards, but also with federal preemption of ambient noise standards. See generally Section VII *infra*.

31. New York City, N.Y., Local Law No. 57, Noise Control Code (Oct. 4, 1972) (to be codified in New York CRR, N.Y., ADMIN. CODE ch. 57).

32. Mention in passing should be made of § 1403.3-2.25 in art. II. Section 1403.3-2.25 deals with city contracts, which are defined to be "any written agreement, purchase order or instrument whereby the city is committed to expend or does expend funds authorized by the capital budget of the city of New York in return for work, labor, services, supplies, equipment, materials, or any combination of the foregoing . . ." *Id.* § 1403.3-2.25(a)(1). All such contracts are to contain the following provisions:

1. Devices and activities which will be operated, conducted, constructed, or manufactured pursuant to the contract and which are subject to the provi-

either in terms of unnecessary noise<sup>33</sup> or in terms of noise emission standards. The drafters of the code incorporated both definitions.<sup>34</sup>

*a. Articles III and IV.* Article III prohibits unnecessary noise: "No person shall make, continue or cause or permit to be made or continued any unnecessary noise."<sup>35</sup>

This prohibition is applied to various devices and animals in article IV.<sup>36</sup> Three of the devices involve traffic noise. Section 1403.3-4.05 prohibits the operation or use of any sound signal device<sup>37</sup> that creates an unnecessary noise.<sup>38</sup> The operation or use of any emergency signal device,<sup>39</sup> "except on an authorized emergency vehicle when such vehicle is in the immediate act of responding to an emergency,"<sup>40</sup> is prohibited by section 1403.3-4.09.

sions of the code will be operated, conducted, constructed or manufactured without causing a violation of the code; and

2. Such devices and activities incorporate advances in the art of noise control developed for the kind and level of noise emitted or produced by such devices and activities.

*Id.* § 1403.3-2.25(b). In addition, the administrator is authorized to issue regulations for devices and activities involved in city contracts. *Id.* § 1403.3-2.25(c). No regulations, however, have been issued.

33. The code defines unnecessary noise as "any excessive or unusually loud sound or any sound which either annoys, disturbs, injures or endangers the comfort, repose, health, peace or safety of a person, or which causes injury to plant or animal life, or damage to property or business." *Id.* § 1403.3-1.05(zz).

34. In this respect, the drafters of the code did what drafters in most other cities are doing. For a discussion of the options available and why the option chosen by New York City is the most popular option, see Section VIII, text accompanying notes 15-20 *infra*.

35. New York City, N.Y., Local Law No. 57, Noise Control Code § 1403.3-3.01 (Oct. 4, 1972).

36. For example, unnecessary noise from sound reproduction devices, and containers (including birds), construction activities, construction devices, and construction materials, respectively, are prohibited. *Id.* §§ 1403.3-4.03, .07, .11, .13, .15.

37. The code defines a sound signal device as "a device designed to produce a sound signal when operated including but not limited to any claxon, air horn, whistle, bell, gong, siren, but not an emergency signal device." *Id.* § 1403.3-1.05(vv).

38. There are five exceptions to the prohibition against unnecessary noise from sound signal devices: (1) a device can be used as a signal of immediate danger; (2) an air horn can be used by an authorized emergency vehicle in the act of responding to an emergency; (3) a steam whistle can be used as a signal of the time to start or stop work or of imminent danger; (4) an audible burglar alarm can be installed, provided the alarm automatically terminates its operation within fifteen minutes (building) or ten minutes (motor vehicle) of being activated; and (5) a device can be installed on a motor vehicle, wagon, or manually propelled cart dispensing food or other items, provided the sound signal is not emitted more frequently than once every ten minutes in any one city block and does not last more than ten seconds. *Id.* § 1403.3-4.05 to .09.

39. The code defines an emergency signal device as "any gong, siren, whistle, or any air horn or any similar device the use of which on authorized emergency vehicles is permitted by [N.Y. Veh. & Traf. Law § 375(26)]." *Id.* § 1403.3-1.05(ee).

40. The code defines an authorized emergency vehicle as

Section 1403.3-4.17 prohibits the use of a device if the discharge of its exhaust creates an unnecessary noise.<sup>41</sup>

Article IV also provides for the creation of noise-sensitive zones. Section 1403.3-4.19 designates schools, hospitals, and courts as noise-sensitive zones.<sup>42</sup> Additional noise-sensitive zones can be created by the Administrator of the New York City Environmental Protection Administration and by the Board of Health if public health and comfort requires.<sup>43</sup>

In these respects, articles III and IV are not fundamentally different from their predecessor, section 435-5.0 of the Administrative Code. Section 1403.3-4.19 of the Noise Control Code, for example, "creates" noise-sensitive zones, but the zones thus created are the same zones recognized by section 435-5.0(b)(8) of the Administrative Code. Arguably, the language of the Noise Control Code is an improvement over the language of section 435-5.0, but the thrust of the provisions is the same.

If articles III and IV were the sum and substance of the Noise Control Code, the code would represent only a minor improvement over section 435-5.0. Any major improvement must be found elsewhere in the code, specifically in article V.

*b. Article V.* Article V establishes noise emission standards for a variety of devices.<sup>44</sup> Noise emission standards for motor vehi-

---

every ambulance and every vehicle operated by a police department, fire department, fire patrol, chief or assistant chief of a fire department, county or deputy county fire co-ordinator, county or assistant county fire marshall, sheriff, or by a chief, assistant chief or deputy chief of a police department, a regular paid deputy sheriff or a motor vehicle of the New York City housing authority when engaged in the performance of duty as a peace officer, or by an authorized public utility company when on emergency calls, every state-owned vehicle operated by a law enforcement officer of the conservation department when engaged in performance of duty in enforcement of the conservation law, and every vehicle operated by a bridge authority or bridge and tunnel authority when on emergency calls.

*Id.* § 1403.3-1.05(k).

41. These devices include, but are not limited to, steam engines, diesel engines, internal combustion engines, and turbine engines. *See id.* § 1403.3-4.17.

42. The noise-sensitive zones created by the code are the same zones recognized by its predecessor, § 435-5.0 of the Administrative Code. *Compare id.* § 1403.3-4.19 with New York City, N.Y., ADMIN. CODE ch. 18, § 435.5-0(b)(8) (1970)(repealed 1972).

43. *See* New York City, N.Y., Local Law No. 57, Noise Control Code § 1403.3-4.21 (Oct. 4, 1972).

If a person suffers undue hardship as a result of the creation of a noise-sensitive zone, he can request a hearing by filing written notice with the Administrator of NYCEPA. A hearing is then held within 10 days of receipt of the request, and a final decision is made within three days of the conclusion of the hearing. *Id.* § 1403.3-4.21(b).

44. The code defines a device as "any mechanism which is intended to or which actually produces sound when operated or handled." *Id.* § 1403.3-1.05(aa).

cles<sup>45</sup> are found in section 1403.3-5.03. The permissible noise level depends on the type of motor vehicle, the speed at which the motor vehicle is moving, and the distance between the motor vehicle and the sound level meter<sup>46</sup> measuring the noise emitted by the motor vehicle.

Table IV-1<sup>47</sup> shows the permissible noise levels for the various classifications of motor vehicles, when measured at distances of 25 feet/7.6 meters and 50 feet/15.2 meters.

TABLE IV-1

Category of vehicle	Permissible Noise Level (in dB(A))			
	Speed limit of 35 mph/ 56 kmph or less		Speed limit of more than 35 mph/ 56 kmph	
	at 50 ft./ 15.2 m.	at 25 ft./ 7.6 m.	at 50 ft./ 15.2 m.	at 25 ft./ 7.6 m.
(1) Any motor vehicle with a manufacturer's gross vehicle rating of 8,000 lbs. or more and any combination of vehicles towed by such motor vehicle	86	96	90	96
(2) Any motorcycle other than a motor-driven cycle:				
before January 1, 1978	82	88	86	92
after January 1, 1978	78	84	82	88
(3) Any other motor vehicle and any combination of vehicles towed by such motor vehicles:				
before January 1, 1978	76	82	82	88
after January 1, 1978	70	76	79	85

45. The code defines motor vehicles as "any device which is propelled by an engine in or upon which a person or material may be transported on the ground and which is intended to be operated upon a public highway." *Id.* § 1403.3-1.05(hh).

46. The code defines a sound level meter as "any instrument including a microphone, an amplifier, an output meter, and frequency weighing networks for the measurement of noise and sound levels in a specified manner and which complies with standards established by the american national standards institute [sic] specifications for sound level meters S1.4-1971, as amended." *Id.* § 1403.3-1.05(rr).

47. Table IV-1 is based on columns I and II of the table found in the code. *Id.* § 1403.3-5.03.



During the same year that New York City enacted its code, the United States enacted the Noise Control Act (NCA).<sup>48</sup> Sections 6 and 18 of the NCA provide for federal noise emission standards. Pursuant to that authorization, the United States Environmental Protection Agency (EPA) published noise emission standards for interstate motor carriers (Motor Carrier Regulations/Motor Carrier Compliance Regulations),<sup>49</sup> published noise emission standards for new medium and heavy-duty trucks (New Truck Regulations),<sup>50</sup> and has published proposed noise emission standards for new garbage trucks, new buses, and new motorcycles.<sup>51</sup>

As a general rule, federal noise emission standards preempt local noise emission standards. The question thus posed is whether and to what extent the New Truck Regulations or the Motor Carrier Regulations/Motor Carrier Compliance Regulations preempt section 1403.3-5.03. Although the noise emission standards found in section 1403.3-5.03 might be interpreted as standards for new motor vehicles, a more plausible interpretation is that they are noise emission standards for in-use motor vehicles. The latter interpretation finds some support in the language of section 1403.3-5.03: "No person shall operate or permit to be operated any motor vehicle . . . ."<sup>52</sup> If this interpretation is correct, section 1403.3-5.03 is preempted by the Motor Carrier Regulations/Motor Carrier Compliance Regulations.

The extent of the preemption, however, still remains to be explored. There are obvious differences and similarities between the Motor Carrier Regulations/Motor Carrier Compliance Regulations and section 1403.3-5.03.

Section 1403.3-5.03 applies to any motor vehicle or motorcycle; the Motor Carrier Regulations/Motor Carrier Compliance Regulations apply to vehicles with a gross vehicle weight rating or a gross combination weight rating in excess of 10,000 pounds operated by a motor carrier in interstate commerce.<sup>53</sup> The Motor

48. For a discussion of the NCA, see Section II-A *supra*.

49. 40 C.F.R. §§ 202.10-.23 (1978); 49 C.F.R. §§ 325.1-.93 (1978).

50. 40 C.F.R. §§ 205.1-.59 (1978).

51. 42 Fed. Reg. 43,226 (1977) (new garbage trucks) (to be codified in 40 C.F.R. §§ 205.200-.209); 42 Fed. Reg. 45,776 (1977) (new buses) (to be codified in 40 C.F.R. §§ 205.100-.109); 43 Fed. Reg. 10,822 (1978) (new motorcycles) (to be codified in 40 C.F.R. §§ 205.150-.174).

52. New York City, N.Y., Local Law No. 57, Noise Control Code § 1403.3-5.03(a) (Oct. 4, 1972).

53. Compare New York City, N.Y., Local Law No. 57, Noise Control Code § 1403.3-5.03(b) (Oct. 4, 1972) with 40 C.F.R. § 202.12 (1978). The code defines motor vehicles as "any device" used to transport people or material and operated on a public highway. *Id.* § 1403.3-1.05(hh).

Carrier Regulations/Motor Carrier Compliance Regulations apply to the motor vehicle itself; section 1403.3-5.03 applies not only to the motor vehicle but also to any combination of vehicles towed by the motor vehicle.<sup>54</sup> Both the Motor Carrier Regulations/Motor Carrier Compliance Regulations and section 1403.3-5.03 draw a distinction between motor vehicles traveling 35 mph/56 kmph or less and motor vehicles traveling faster than 35 mph/56 kmph.<sup>55</sup> Both use a similar procedure to measure the noise emitted. Both set the same permissible noise level for heavy motor vehicles:<sup>56</sup> 86 dB(A) for motor vehicles traveling 35 mph/56 kmph or less and 90 dB(A) for motor vehicles traveling faster than 35 mph/56 kmph.<sup>57</sup>

At a theoretical level, one could make the following assessment about the impact of the Motor Carrier Regulations/Motor Carrier Compliance Regulations on section 1403.3-5.03: The Motor Carrier Regulations/Motor Carrier Compliance Regulations preempt only that portion of section 1403.3-5.03 that regulates heavy motor vehicles. This limited preemption, moreover, is of no real significance since the permissible noise levels are identical. Unfortunately, this theoretical assessment bears no resemblance to the realities of the situation. The only portion of section 1403.3-5.03 that New York City has ever enforced is the portion that regulates heavy motor vehicles.<sup>58</sup> And, although the permissible noise levels are identical, the measurement procedures are dissimilar. New York City, for example, allows a tolerance of two feet when taking its measurement at 50 feet/15.2 meters, while the federal guidelines make no such allowance. New York City's Bureau of Enforcement, therefore, no longer enforces

---

54. Compare 40 C.F.R. § 202.12(c) (1978) with New York City, N.Y., Local Law No. 57, Noise Control Code § 1403.3-5.03(b) (Oct. 4, 1972).

55. Compare 40 C.F.R. § 202.20 (1978) with New York City, N.Y. Local Law No. 57, Noise Control Code § 1403.3-5.03(b) (Oct. 4, 1972).

56. The Motor Carrier Regulations/Motor Carrier Compliance Regulations apply to motor vehicles with a gross vehicle weight rating in excess of 10,000 lbs.; category (1) of § 1403.3-5.03 applies to motor vehicles with a manufacturer's gross vehicle rating of 8000 lbs. or more.

57. Compare 40 C.F.R. § 202.20 (1978) with New York City, N.Y., Local Law No. 57, Noise Control Code § 1403.3-5.03(b) (Oct. 4, 1972).

58. Telephone conversation with Peter Mancusio, Principal Air Pollution Inspector, Bureau of Enforcement (Nov. 20, 1979).

An attempt was made in April 1979 to enforce that portion of § 1403.3-5.03 that regulates motorcycles because of numerous complaints made by residents along a particular highway in the borough of Brooklyn. This attempt was unsuccessful. One citation was issued, but the citation was for a faulty muffler rather than for a violation of § 1403.3-5.03. *Id.*

section 1403.3-5.03 because of the discrepancies between the two measuring procedures.<sup>59</sup> As a result of federal preemption, enforcement of section 1403.3-5.03, which once could be described as minimal, is now nonexistent.<sup>60</sup>

Several other sections in article V involve traffic noise. Section 1403.3-5.15 establishes 70 dB(A) as the permissible noise level for refuse compacting vehicles<sup>61</sup> manufactured after December 31, 1974, when measured at 10 feet/3 meters from the center line of the compacting unit.<sup>62</sup> In contrast to section 1403.3-5.03, which is an *in-use* noise emission standard, section 1403.3-5.15 is a standard for *new* refuse compacting vehicles. On August 26, 1977, EPA proposed New Garbage Truck Regulations.<sup>63</sup> The permissible noise levels under the proposed New Garbage Truck Regulations are 78 dB(A) as of January 1, 1979, and 75 dB(A) as of January 1, 1982, when measured 23 feet/7 meters from the truck-mounted solid waste compactor.<sup>64</sup> Thus, both the permissible noise levels and the measuring procedures differ. New York City, therefore, will be preempted from enforcing section 1403.3-5.15 if the proposed New Garbage Truck Regulations become final. Since New York City does not now enforce section 1403.3-5.15,<sup>65</sup> the adverse impact of federal preemption is more imagined than real.

The permissible noise level established by section 1403.3-5.17 for claxons<sup>66</sup> on any motor vehicle beginning with the 1974 model

59. In order to correct these discrepancies and bring § 1403.3-5.03 into conformity with the Motor Carrier Regulations/Motor Carrier Compliance Regulations, a revised § 1403.3-5.03 has been proposed. The New York City Council, however, has yet to act on this revision. Telephone conversation with Robert Bennin, Director, Bureau of Noise Abatement (Nov. 15, 1979).

60. See Table IV-5 *infra*.

61. The code defines a refuse compacting vehicle as "a motor vehicle designed to compact and transport refuse." New York City, N.Y., Local Law No. 57, Noise Control Code § 1403.3-1.05(pp) (Oct. 4, 1972).

62. To state that the permissible noise level is 70 dB(A) is somewhat misleading. First, variances of up to 75 dB(A) are routinely granted. Second, a measurement tolerance factor of  $\pm 3$  dB(A) is permitted. Thus, the permissible noise level is really 78 dB(A), and all refuse compacting vehicles tested have satisfied this standard. Telephone conversation with Robert Bennin, Director, Bureau of Noise Abatement (Nov. 15, 1979).

63. See note 51 and accompanying text *supra*.

64. 42 Fed Reg. 43,226, 43,234 (1977) (to be codified in 40 C.F.R. § 205.202).

65. Telephone conversation with Robert Bennin, Director, Bureau of Noise Abatement (Nov. 15, 1979).

When the New Garbage Truck Regulations become final, § 1403.3-5.15 will be revised to bring it into conformity with the New Garbage Truck Regulations. *Id.*

66. The code defines claxons as "any manually, mechanically, or electrically powered device, other than an emergency signal device, including but not limited to a motor vehicle

year is 75 dB(A). All 1974 and subsequent model year motor vehicles are equipped with city-country horns. New York City's Bureau of Noise Abatement has taken the position that these horns satisfy section 1403.3-5.17.<sup>67</sup> Section 1403.3-5.19 establishes 90 dB(A) as the permissible noise level for emergency signal devices after June 30, 1973. Pursuant to section 1403.3-5.23, the Administrator of NYCEPA can issue regulations regarding the standards and procedures to be followed in measuring the permissible noise level.<sup>68</sup>

*c. Article VI.* The code states: "[I]t is the public policy of the city that every person is entitled to ambient noise levels that are not detrimental to life, health and enjoyment of his property."<sup>69</sup> The code defines ambient noise as "the all-encompassing noise associated with a given environment, being usually a composite of sounds from many sources near and far."<sup>70</sup>

Article VI is addressed to ambient noise quality zones<sup>71</sup> and the criteria and standards applicable within each zone. In establishing ambient noise quality zones, the administrator is to consider seven factors:

- (i) The uses and activities permitted by zoning regulations in such zones;
- (ii) The intensity of sound levels produced by activities and devices in such zones;
- (iii) The time at which such sound levels occur;
- (iv) The duration of such sound levels;
- (v) The proximity of such activities and devices to buildings and to dwellings;
- (vi) Whether the sound levels produced by such devices and activities are recurrent, intermittent or constant; and
- (vii) The density of habitation of such zones.<sup>72</sup>

Ambient noise quality criteria and standards should reflect "the

horn, which is intended to, and when operated actually does, emit a sound signal." New York City, N.Y., Local Law No. 57, Noise Control Code § 1403.3-1.05(t) (Oct. 4, 1972).

67. Interview with Dr. Roy Gerson, former Director, Bureau of Noise Abatement (Sept. 21, 1973).

68. No such regulations have yet been promulgated.

69. New York City, N.Y., Local Law No. 57, Noise Control Code § 1403.3-1.03 (Oct. 4, 1972) The scope of this declaration is significant. In addition to noise levels detrimental to life and health, noise levels detrimental to enjoyment of property are to be avoided.

70. *Id.* § 1403.3-1.05(i).

71. Ambient noise quality zones are geographic areas which share an environmental noise level. *See id.* § 1403.3-6.01.

72. *Id.* § 1403.3-6.01(1).

latest scientific knowledge . . . indicating the . . . identifiable effects . . . of noise abatement."<sup>73</sup>

The code required the administrator to submit proposed ambient noise quality zones and the criteria and standards applicable within each ambient noise quality zone to the New York City Council for enactment on or before September 1, 1974.<sup>74</sup> New York City's Bureau of Noise Abatement prepared a document entitled "Ambient Noise Quality Zones Criteria and Standards" and submitted it to the New York City Council in July 1975.<sup>75</sup> This document proposed the formulation of three distinct ambient noise quality zones. These zones, designated N-1, N-2, and N-3, were created by grouping existing land-use zones.<sup>76</sup> The document also proposed ambient noise standards for these three zones. The standards were based on "previous noise level data, recent noise measurement programs, and computer simulation and analysis efforts."<sup>77</sup> These proposals are summarized in Table IV-2.<sup>78</sup>

TABLE IV-2

Ambient Noise Quality Zone	Description	Daytime <sup>79</sup> Standard (in dB(A))	Nighttime <sup>80</sup> Standard (in dB(A))
N-1	Low Density Residential	60	50
N-2	High Density Residential	65	55
N-3	All Commercial and Manufacturing	70	70

73. *Id.* § 1403.3-6.01(2).

74. *Id.* § 1403.3-6.01.

75. Ambient Noise Quality Zones Criteria and Standards, [1976] New York City Record 147.

For a discussion of how New York City's ambient noise quality zones were developed, see Stempler, Sanders, Watkins, & Boronow, *Development of Environmental Noise Codes for the City of New York*, SOUND AND VIBRATION, Dec. 1977, at 18.

76. Zones R-1 through R-3 were combined and designated N-1; zones R-4 through R-10 were combined and designated N-2; and zones C-1 through C-8 and M-1 through M-3 were combined and designated N-3. See [1976] New York City Record 151.

77. *Id.* at 147.

78. Table IV-2 is an adaptation of two tables that appear in the Bureau of Noise Abatement document. *Id.* at 151.

79. Daytime is the period between 7:00 a.m. and 10:00 p.m. *Id.*

80. Nighttime is the period between 10:00 p.m. and 7:00 a.m. *Id.*

Although the document was submitted to the New York City Council during the summer of 1975, no action was taken until the New York City Council passed, and Mayor Edward Koch signed, Local Law 64 on October 19, 1979.<sup>81</sup>

## 2. *Enforcement*

The Bureau of Noise Abatement and the Bureau of Enforcement are responsible for controlling noise in New York City.<sup>82</sup> The Bureau of Noise Abatement, concerned primarily with the technical aspects of noise regulation, is staffed by approximately ten people and is organized as follows:

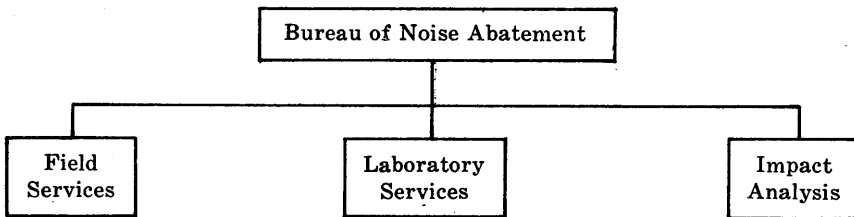

All Bureau of Noise Abatement personnel are professionals with college degrees. Many are acoustical engineers.<sup>83</sup>

New York City's Bureau of Enforcement is staffed by approximately eighteen people and is organized as follows:

81. New York City, N.Y., Local Law No. 64 (Oct. 19, 1979).

82. A superagency, the New York City Environmental Protection Administration, existed when the Noise Control Code was enacted. This superagency subsequently was abolished and replaced by the Department of Environmental Protection and the Department of Sanitation. The Department of Environmental Protection is composed of two divisions, the Division of Air Resources and the Division of Water Resources. The Bureau of Noise Abatement is a bureau within the Division of Air Resources.

83. Interview with Samuel Stempler, Director, Bureau of Noise Abatement (Mar. 3, 1978).

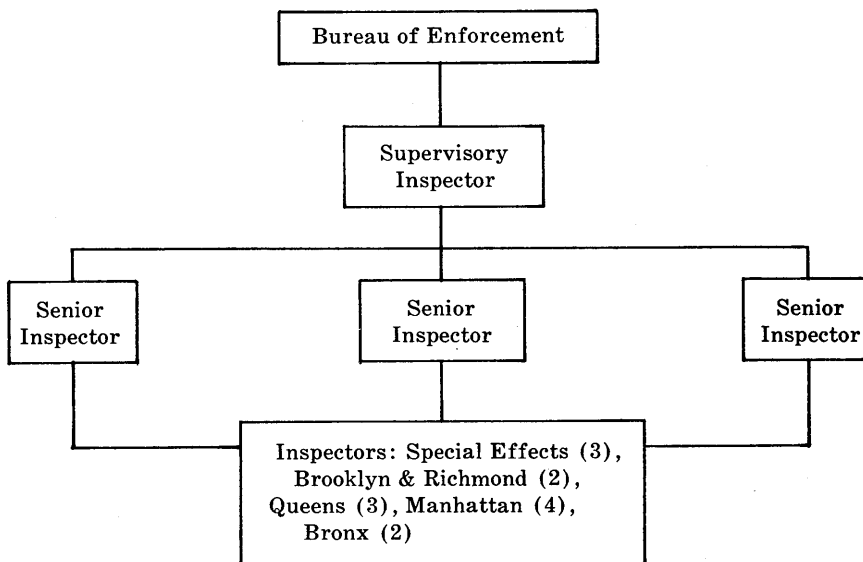

As shown above, most of the inspectors are assigned to one of New York City's five boroughs.<sup>84</sup> Before each inspector is assigned, he must successfully complete a one-week course in which he divides his time between instruction and field training.<sup>85</sup>

Two factors, the limited number of enforcement personnel and the scope of the noise problem in New York City, have resulted in a division of responsibilities for enforcing the code. Interpersonal noise is the responsibility of the police,<sup>86</sup> mechanical noise is the responsibility of the Bureau of Enforcement.

Table IV-3<sup>87</sup> shows by year the total number of citations issued for violations of the Noise Control Code, the number of those citations that were issued for unreasonable noise violations,<sup>88</sup> and the number of those citations that were issued for noise emission standards violations.<sup>89</sup>

84. Telephone conversation with Peter Mancusio, Principal Air Pollution Inspector, Bureau of Enforcement (Nov. 20, 1979).

All of the staff are certified as air inspectors. Approximately two-thirds of the staff are certified as noise inspectors. *Id.* For a discussion of the certification process for noise inspectors, see text accompanying note 85 *infra*.

85. Telephone conversation with Peter Mancusio, Principal Air Pollution Inspector, Bureau of Enforcement (Nov. 20, 1979).

86. Interpersonal noise is noise caused by people. If citizen A is annoyed by citizen B's stereo, citizen A should call the police rather than the Bureau of Enforcement.

87. Statistics in Tables IV-3, IV-4, and IV-5 were compiled by New York City's Bureau of Enforcement and supplied to the author.

88. Unreasonable noise violations are violations of arts. III or IV of the code.

89. Noise emission standards violations are violations of art. V of the code.

TABLE IV-3

Noise Control Code Citations						
Year	Total Number of Citations	Percentage Change from Previous Year	Unreasonable Noise Citations	Percentage of Total Citations	Noise Emission Standards Citations	Percentage of Total Citations
1972	148	—	123	83	25	17
1973	3,188	+2,054	2,287	72	901	28
1974	3,507	+10	886	25	2,621	75
1975	1,651	-53	677	41	974	59
1976	453	-73	109	24	344	76
1977	164	-64	107	65	57	35
1978	125	-24	72	58	53	42

Over the seven-year period, 1972-1978, the total number of citations issued for violations of the code rose and fell dramatically. The increase of nearly 2100% in 1973 is due in part to the fact that the 1972 figure only represents a three-month period and in part to increasing citizen awareness of the code.<sup>90</sup> The dramatic decreases of 53% and 73% found in 1975 and 1976 can be attributed in large part to the financial woes of New York City, which prevented the hiring of new personnel and the purchase of additional equipment and led to significant personnel reductions. By 1978 the total number of citations had fallen below the three-month total for 1972. Table IV-3 also illustrates the wide variance in the percentages of citations issued for unreasonable noise violations (ranging from 83% to 24% of the total number of citations issued) and noise emission standards violations.

Table IV-4 shows by year the total number of unreasonable noise citations and a breakdown of those citations by code category.

90. As awareness increased, citizens were more likely to report violations.



TABLE IV-4

Unreasonable Noise Citations						
Year	Total Number of Citations	Un-necessary Noise	Sound Reproduction Devices	Sound Signal Devices	After Hours Construction	Un-necessary Construction Noise
1972	123	3	115	—	5	—
1973	2,287	116	1,453	420	59	239
1974	886	83	568	200	30	5
1975	677	66	457	13	129	12
1976	109	37	67	1	4	—
1977	107	23	78	5	1	—
1978	125	12	49	4	6	1

During the seven-year period, sound reproduction devices constituted the major source of unreasonable noise for which citations were issued. Several of the other categories fluctuated wildly, presumably resulting from varying enforcement efforts. For example, the sharp increase in citations issued for sound signal device violations in 1973 can be attributed to a campaign carried out during June and July during which citations for unnecessary hornhonking were issued.<sup>91</sup> The construction noise categories, with the exception of after-hours construction citations in 1975 and general construction citations in 1973, have not been a significant enforcement factor.

Table IV-5 shows by year the total number of noise emission standards citations and a breakdown of those citations by code category.

91. Telephone conversation with Peter Mancusio, Director, Bureau of Enforcement (May 15, 1974).

TABLE IV-5

Year	Noise Emissions Standards Citations						
	Total Number of Citations	Motor Vehicles	Air Com- pressors	Air Circula- tion Devices	Claxons	Sirens	Paving Breakers
1972	25	—	3	7	—	—	15
1973	901	9	219	86	52	—	535
1974	2,621	2,124	44	167	164	2	120
1975	974	765	20	144	—	—	45
1976	344	234	6	82	—	—	22
1977	57	1	3	38	—	—	15
1978	125	2	6	26	1	1	17

Table IV-5 demonstrates that, unlike the unnecessary noise citations where one category has been dominant, all categories of noise emission standards citations have fluctuated. Nonetheless, two dramatic shifts are evident. The most important, for purposes of this study, is the rise and fall of motor vehicle citations. The increase resulted primarily because the Bureau of Enforcement began enforcing the truck noise emission standards on December 19, 1973. Monitoring stations were established at several points where trucks enter the New York City area. The number of citations rose from 9 in December 1973 to 344 in April 1974,<sup>92</sup> owing to the growing enthusiasm and increasing proficiency of the inspectors.<sup>93</sup> On April 16, 1974, for example, 917 trucks entering New York City were monitored and 28 citations were issued. The number of citations dropped off after April because of personnel problems.<sup>94</sup> The drop in citations issued for motor vehicle violations in 1976, 1977, and 1978 may be attributed to the adoption of the federal Motor Carrier Compliance Regulations and the

92. *Id.*

93. Not only New York City officials but also New York City Bureau of Enforcement personnel had been skeptical about the success of a program to enforce the truck noise emission standards. As the number of notices of violation increased and the trucking industry responded by taking corrective action, enthusiasm for the program grew.

94. Because of a cutback in funds, all provisional inspectors were fired. This action had a direct effect on the program to enforce the truck noise emission standards since a sizable number of the inspectors in the truck noise emission detail were provisional inspectors.

growing concern of the Bureau of Enforcement that local laws had been preempted.

The other significant shift is found in paving breaker citations. The number of citations dropped from highs of 60% and 59% of the total number of noise emission citations in years 1972 and 1973, to 4% in 1974, remained stable until 1977, then rose to 14% in 1978.

### 3. *Evaluation of the code and its enforcement*

Tables IV-3, IV-4, and IV-5 point out two enforcement problems. One is the shift that occurred in 1977 from noise emission standards citations to unreasonable noise citations. Whenever citations for unreasonable noise violations as a percentage of total citations are high, the number of noise emission standards citations involving traffic noise tends to be low. Unreasonable noise citations, for example, as a percentage of total citations were high in 1972, 1973, and 1977. In those same three years the number of noise emission standards citations involving motor vehicles were zero, nine, and one, respectively. The results in 1977 are ominous. They suggest that a turnabout may have occurred and that noise emission standards citations may lag behind unreasonable noise citations for the foreseeable future.

The other problem is the general decline in the total number of citations—unless that decline can be attributed to an ever-higher degree of voluntary compliance on the part of operators. Total citations dropped to 164 in 1977, which was only slightly more than 1972's three-month total of 148. Traffic noise accounted for only six citations, or four percent of the total.<sup>95</sup>

Do these six traffic noise citations represent a successful enforcement program and indicate a high degree of compliance on the part of operators? In part, they do. Both New York City's Bureau of Enforcement, which enforces the code, and the Bureau of Motor Carrier Safety, which enforces the Motor Carrier Compliance Regulations, have noted a similar pattern: Citations are initially quite high; they then tend to decline as operators bring their motor vehicles into compliance with the regulations. Most trucks now comply with the 86 dB(A) noise emission standard. This high degree of compliance, however, is misleading because 86 dB(A) does not represent the noise emission standard achieve-

---

95. Included in the six traffic noise citations were one motor vehicle noise emission standards citation and five sound signal devices unreasonable noise citations. See Tables IV-4, IV-5.

ble using the best available technology.<sup>96</sup> Moreover, the small number of traffic noise citations also resulted from something other than a successful enforcement program. New York City's financial problems have made it impossible for the city to hire new personnel and purchase new equipment. Indeed, the Bureau of Enforcement has reduced and consolidated its staff.<sup>97</sup> Another culprit is federal preemption. As has already been mentioned, the Bureau of Enforcement no longer enforces the noise emission standards for motor vehicles because of the variance in federal and local measuring systems.

In addition to the foregoing rather obvious problems, a variety of less obvious problems have bedeviled New York City's enforcement efforts. The code itself is troublesome. Some provisions, such as section 1403.3-3.07, prohibiting unnecessary bird noise, should not have been included since they create rather than solve problems. Other provisions, such as a prohibition on refuse collection between certain hours,<sup>98</sup> should have been included but were not. Still other provisions have proven to be ineffective because of their questionable constitutionality. Section 1403.3-2.07 permits warrantless inspections. No attempt has been made to use this provision because of the fear that the provision offends the constitutional prohibition against unreasonable searches.<sup>99</sup> Section 1403.3-2.11 prohibits anyone from interfering with or obstructing Bureau of Noise Abatement or Bureau of Enforcement personnel. This provision has not been used because of concern that it is overly broad.

Various code provisions have been interpreted as requiring an inspector's presence when the device allegedly violating the

---

96. See Section II, note 562 and accompanying text *supra*.

97. The Bureau of Enforcement originally consisted of one division, staffed by air inspectors. When the Noise Control Code was enacted, additional staff were hired and a second division was created. This second division, a noise squad, consisted of 1 supervisory inspector, 2 senior inspectors, and 10 inspectors. As a result of New York City's financial problems, the separate air and noise divisions were consolidated into a single division, and the total number of staff was reduced. Telephone conversation with Peter Mancusio, Principal Air Pollution Inspector, Bureau of Enforcement (Nov. 20, 1979).

Although the Bureau of Enforcement is responsible for air pollution and noise, the focus of its activity has clearly shifted to air pollution. Enforcement of the Noise Control Code now takes place purely on a complaint basis. Telephone conversation with Robert Bennin, Director, Bureau of Noise Abatement (Nov. 15, 1979).

98. Although the code prohibits construction between certain hours, there is no comparable provision for refuse collection. Refuse collection should not be permitted between 8:00 p.m. and 6:00 a.m.

99. Given the Supreme Court's recent decision reinforcing the warrant requirements in administrative searches and seizures, this fear appears to have been justified. See *Marshall v. Barlow's, Inc.*, 436 U.S. 307 (1978).

provisions of the code is in operation in order for a notice of violation to issue.<sup>100</sup> A solution to this particular problem is to grant noise inspectors the power to examine a device not in operation and to issue a "notice of repair" if the inspector has "reasonable cause" to believe that the device violates the provisions of the code. No penalty would be imposed if the owner or operator of the device supplied the Bureau of Enforcement with either a certificate of repair or the results of a test indicating that the device complied with the provisions of the code.

A final problem that deserves attention is the attitude of the courts. During June and July 1973 a significant number of citations for hornhonking were issued under the provisions of section 1403.3-4.05. Many of those who received a citation questioned the necessity of appearing in court and the severity of the fifty dollar fine. Apparently, the courts agreed with the latter objection because fines of only two dollars were imposed.<sup>101</sup> Enforcement under these circumstances became impractical and no attempt has been made to control hornhonking since that time.

---

100. Interview with Peter Mancusio, Director, Bureau of Enforcement (Sept. 21, 1973).

101. Imposing too large a fine can be counterproductive, since offenders will be more likely to contest the fine in court. Because the officer who issued the citation would likely be unable to recall relevant details of the occurrence, many offenders could avoid the penalty.

## SECTION V

### REGULATION OF TRAFFIC NOISE IN THE FEDERAL REPUBLIC OF GERMANY

The Federal Republic of Germany,<sup>1</sup> as its name implies, is a federal system. Its constitution<sup>2</sup> enunciates certain basic principles. Article 2 defines personal rights.<sup>3</sup> Property rights are defined by article 14.<sup>4</sup>

The West German Constitution also enumerates exclusive powers<sup>5</sup> exercised by the federal government, and concurrent powers<sup>6</sup> exercised concurrently by the federal government and the state governments. Noise regulation was not one of the enumerated powers in the constitution as originally adopted. In 1969 a proposal advocating the addition of noise regulation to the list of exclusive powers was opposed by the states<sup>7</sup> and was ultimately vetoed by the Bundesrat.<sup>8</sup> In 1972, however, noise regulation was added to the list of concurrent powers.<sup>9</sup>

Traffic noise laws in the Federal Republic of Germany have passed or are passing through three distinct but overlapping phases: a general law phase, a noise emission standards phase, and an ambient noise level standards phase. Under this evolving

---

1. Bundesrepublik Deutschland.

2. GRUNDGESETZ [GG] (W. Ger.). Selected excerpts are reprinted in 1 E. GOSSRAU, H. STEPHANY, W. CONRAD & W. DÜRRE, HANDBUCH DES LÄRMSCHUTZES UND DER LUFTREINHALTUNG (Handbook of Noise Control and Clean Air Maintenance) ¶ 10,025 (1969-1979) [hereinafter cited as NOISE HANDBOOK].

3. "Everyone has the right to life and to inviolability of his person. . . . These rights can only be encroached upon pursuant to a law." GG art. 2, § 2.

4. The Constitution states:

(1) Property [rights] . . . are guaranteed. Their content and limits are determined by law.

(2) Property carries with it certain responsibilities. Its use should serve the good of the community.

(3) Expropriation is only permissible when the good of the community requires it . . . and can only take place in accordance with a law which regulates the nature and amount of compensation to be paid. In determining the amount of compensation, the interests of the property owner and the community should be weighed. The ordinary courts are available in those cases where agreement cannot be reached with respect to the amount of compensation. *Id.* art. 14.

5. *Id.* art. 73. Significantly, art. 90 of the constitution states that "the federal government is the owner of the Federal Freeways and Highways." *Id.* art. 90, § 1.

6. *Id.* arts. 72, 74.

7. See 1 NOISE HANDBOOK, *supra* note 2, ¶ 00,150, at 2.

8. The Federal Republic of Germany has a bicameral legislature similar to the United States Congress. The *Bundestag* is the lower chamber; the *Bundesrat* is the higher chamber.

9. Article 74, § 24 states that "the concurrent powers encompass . . . noise regulation." GG art. 74, § 24.

system of regulation, the Federal Republic of Germany has established the following goal: "No one should be endangered, seriously injured, or annoyed by noise."<sup>10</sup>

### A. Phase One: General Laws

The earliest phase of German traffic noise law was the general law phase, which relied on the traditional tort and criminal remedies fashioned by the Civil Code<sup>11</sup> and the Penal Code.<sup>12</sup> Although this phase was important, reliance on these traditional remedies has waned. No attempt, therefore, will be made to examine general laws exhaustively.

#### 1. Civil Code provisions

The Civil Code deals with noise indirectly—as a nuisance.<sup>13</sup> Section 823 defines the duty of care: "Whoever, intentionally or negligently, encroaches upon another's right to life, health, freedom, property, or other similar rights must indemnify the other person for damages arising out of such encroachment."<sup>14</sup> Succeeding sections outline in greater detail some of the protected rights. Section 862 protects a possessor's right to quiet enjoyment of his property: "If possession is arbitrarily disturbed, the possessor can require the party creating the disturbance to eliminate the disturbance. The possessor can bring an action in default if the disturbance continues."<sup>15</sup> Section 906 protects an owner from disturbances originating outside the boundaries of his property and requires him to tolerate certain disturbances.<sup>16</sup>

---

10. DER RAT VON SACHVERSTÄNDIGEN FÜR UMWELTFRAGEN, UMWELTGUTACHTEN 1974 (Environmental Assessments 1974), at 17 (1974) [hereinafter cited as ENVIRONMENTAL REPORT].

11. Bürgerliches Gesetzbuch [BGB] art. 195 (W. Ger.). Selected excerpts are reprinted in 1 NOISE HANDBOOK, *supra* note 2, ¶ 12,025.

12. Strafgesetzbuch [StGB] art. 127 (W. Ger.). Selected excerpts are reprinted in 1 NOISE HANDBOOK, *supra* note 2, ¶ 11,025.

13. For a discussion of Anglo-American nuisance law as applied to the problem of noise, see Lloyd, *Noise as a Nuisance*, 82 U. PA. L. REV. 567 (1934).

14. BGB § 823.

15. *Id.* § 862. No cause of action against the party creating the disturbance or his legal predecessor is available, however, to a possessor who occupies by adverse possession.

16. This section states:

The owner of property must tolerate the introduction of . . . noise [or] vibration . . . from an adjacent property so long as there is either no impact or only a minor impact on the use of his property.

Even if the impact is major, the owner of the property has the same duty of toleration if the [noise or vibration] arises from a use of the adjacent property which is normal for the area and the impact of the [noise or vibration] cannot

## 2. Penal Code provisions

Through the first hundred years of its existence, the Penal Code dealt directly with noise.<sup>17</sup> Section 360(1)(11) prohibited excessive noise,<sup>18</sup> section 366 sought to preserve the tranquility of Sundays and holidays, and section 367 limited the use of weapons or fireworks in inhabited areas. In 1962 the Grand Commission for Penal Reform submitted a "Draft of a Penal Code" (1962 Draft)<sup>19</sup> to the Bundestag. The 1962 Draft has been described as

---

be minimized by the user through measures which are reasonably feasible. If the use is not normal for that area or the impact can be minimized through reasonable measures, the owner can require the user to pay compensation.

BGB § 906. For a discussion of § 906 as applied to the problem of noise, see B. KLEINDIENST, RECHT UND STAAT: DER PRIVATRECHTLICHE IMMISSIONSSCHUTZ NACH § 906 BGB (1964) (Heft 298/299); H. WIETHAUP, LÄRMBEKÄMPFUNG IN DER BUNDESREPUBLIK DEUTSCHLAND 91-108 (2d ed. 1967).

Both the Reichsgericht (German Supreme Court) and its successor, the Bundesgerichtshof (Federal Supreme Court), have considered motor vehicle noise cases invoking § 906. See, e.g., Judgment of Nov. 30, 1970, Bundesgerichtshof, W. Ger., 4 NOISE HANDBOOK, *supra* note 2, ¶ 58,127 (V ZR 51/68) (truck noise); Judgment of Oct. 30, 1970, Bundesgerichtshof, W. Ger., 54 Entscheidungen des Bundesgerichtshofes in Zivilsachen [BGHZ] 384 (V ZR 150/67) (highway noise), *reprinted in* 4 NOISE HANDBOOK, *supra* note 2, ¶ 58,136; Judgment of Dec. 22, 1967, Bundesgerichtshof, W. Ger., 49 BGHZ 148 (V ZR 11/67) (highway noise), *reprinted in* 4 NOISE HANDBOOK, *supra* note 2, ¶ 58,121; Judgment of June 15, 1967, Bundesgerichtshof, W. Ger., 48 BGHZ 98 (III ZR 23/65) (highway noise), *reprinted in* 4 NOISE HANDBOOK, *supra* note 2, ¶ 58,119; Judgment of Jan. 9, 1939, Reichsgericht, Ger., 4 NOISE HANDBOOK, *supra* note 2, ¶ 58,106 (V 154/38) (highway noise).

17. StGB § 223 prohibits intentional acts that cause physical abuse or impairment of health. This provision is not discussed in the text because noise can seldom be shown to have caused physical abuse or impairment of health. 1 NOISE HANDBOOK, *supra* note 2, ¶ 00,150. For a case where physical abuse was shown, see Judgment of July 18, 1956, Landgericht Bad Kreuznach, W. Ger., 4 NOISE HANDBOOK, *supra* note 2, ¶ 60,104 (6 Ns 225/55) (starting trucks with diesel motors at night in a residential area).

18. StGB § 360(1)(11) (repealed 1974). For a discussion of § 360(1)(11), see H. WEITHAUP, *supra* note 16, at 125-30.

There are numerous motor vehicle noise cases based on § 360(1)(11). See, e.g., Judgment of Mar. 10, 1967, Oberlandesgericht Hamm, W. Ger., 4 NOISE HANDBOOK, *supra* note 2, ¶ 60,121 (1 Ss 31/67) (frequent to and fro driving in a district inhabited by prostitutes); Judgment of Aug. 4, 1960, Oberlandesgericht Hamm, W. Ger., 4 NOISE HANDBOOK, *supra* note 2, ¶ 60,109 (2 Ss 426/60) (unloading a motor vehicle at night); Judgment of Mar. 21, 1961, Oberlandesgericht Köln, W. Ger., 4 NOISE HANDBOOK, *supra* note 2, ¶ 60,111 (Ss 525/60) (idling motor); Judgment of Nov. 19, 1957, Oberlandesgericht Oldenburg, W. Ger., 4 NOISE HANDBOOK, *supra* note 2, ¶ 60,106 (Ss 331/57) (starting trucks at night in a residential area); Judgment of Dec. 20, 1965, Oberlandesgericht Stuttgart, W. Ger., 4 NOISE HANDBOOK, *supra* note 2, ¶ 60,120 (3 Ss 605/65) (frequent to and fro driving in a residential area).

19. Entwurf eines Strafgesetzbuches (Draft Penal Code), Drucksache IV/650, Bundestag, IV. Wahlperiode (1962). For a brief discussion of the attempts in this century to completely revise the Penal Code, see Eser, *The Politics of Criminal Law Reform: Germany*, 21 AM. J. COMP. L. 245-47 (1973). For a discussion of the 1962 Draft, see Mueller, *The German Draft Criminal Code 1960—An Evaluation in Terms of American Criminal Law*, 1961 U. ILL. L.F. 25.



"a codified commentary on the old Penal Code."<sup>20</sup>

Disappointed with the 1962 Draft, a group of younger legal scholars prepared an "Alternative Draft of a Penal Code" (Alternative Draft).<sup>21</sup> The Alternative Draft retained noise violations as a part of the Penal Code but consolidated sections 360, 366, and 367 into a new section entitled "Noise Pollution."<sup>22</sup> In revising the Penal Code in 1975,<sup>23</sup> the German Legislature decided to abolish some violations and to transfer other violations, including noise violations, from the Penal Code to the Law of Administrative Offenses.<sup>24</sup> Section 117 of the Law of Administrative Offenses prohibits undue noise.<sup>25</sup>

The failure of the general laws to adequately regulate noise can be traced in large measure to the so-called "General Clause."<sup>26</sup> Under the General Clause, a threat to public safety or order is a condition precedent to police action. Either "dangers to public health"<sup>27</sup> or "nuisances"<sup>28</sup> may constitute threats to public safety or order. Dangers to public health always constitute threats to public safety or order. Unfortunately, since medical certainty about the public health danger of noise is arguably lacking, the German police proceed cautiously. They have to be persuaded that a particular noise endangers public health before they will act.

Not all nuisances, therefore, constitute threats to public safety or order. There have been two responses to this problem. One has been to convert some nuisances into dangers to public health. At an early date, for example, nuisances that disturb

20. Eser, *supra* note 19, at 247.

21. Alternativ-Entwurf eines Strafgesetzbuches. For an English translation of the Alternative Draft, see 21 THE AMERICAN SERIES OF FOREIGN PENAL CODES: ALTERNATIVE DRAFT OF A PENAL CODE FOR THE FEDERAL REPUBLIC OF GERMANY (1977).

22. *Id.* § 154.

23. Bekanntmachung der Neufassung des Strafgesetzbuches (Publication of the New Version of the Penal Code), Jan. 2, 1975, [1975] Bundesgesetzblatt [BGBl] I 1. For an excellent discussion of the revised Penal Code, see *Symposium: The New German Penal Code*, 24 AM. J. COMP. L. 589 (1976).

24. Law of Jan. 2, 1975, [1975] BGBl I 80.

25. *Id.* § 117, reprinted in A. SCHÖNKE & H. SCHRÖDER, KOMMENTAR ZUM STRAFGESETZBUCH (Commentary to the Penal Code) 1863, 1865 (1976).

26. Die polizeirechtliche Generalklausel. For a discussion of the General Clause, see H. WIETHAUP, *supra* note 16, at 77, 139; 1 NOISE HANDBOOK, *supra* note 2, ¶ 00,150.

27. The German term for dangers to public health is Gesundheitsgefahr.

28. The German term for nuisance is Belästigung. A nuisance is "an injury to well-being, which is not an illness but . . . [which] detrimentally affects concentration at work, relaxation, sleep or the soundness of sleep or makes conversation or understanding more difficult." 1 NOISE HANDBOOK, *supra* note 2, ¶ 00,150.

sleep were converted into dangers to public health.<sup>29</sup> Another response has been to draw a distinction between an "actionable nuisance" and all other nuisances and to require police intervention if the nuisance is actionable. Over the years, the concept of actionable nuisance has slowly expanded to include nuisances that disturb public order.

Since the traditional tort and criminal remedies fashioned by the Civil Code and the Penal Code were not particularly successful in regulating noise, the Federal Republic of Germany has turned increasingly to administrative remedies. These administrative remedies are found in "special" laws. These special laws are of two types: noise emission standards and ambient noise level standards.

### *B. Phase Two: Noise Emission Standards*

Noise emission standards are the second phase of German traffic noise law. This phase, unlike the other two, has ceased to be national and has become international.

Noise emission standards are drawn from two sources. One source is German law. This law consists of the following laws, ordinances, regulations, and guidelines: the Motor Vehicle Law (StVG),<sup>30</sup> the Motor Vehicle Ordinance (StVO),<sup>31</sup> the Motor Vehicle Regulations (Regulations),<sup>32</sup> the General Administrative Regulations Governing the Issuance of a Warning (Warning Regulations),<sup>33</sup> the Motor Vehicle Approval Ordinance (StVZO),<sup>34</sup> the

29. In the early 1900's the Prussian Oberverwaltungsgericht (Administrative Appeals Court of Prussia) not only equated nuisances that disturb sleep with dangers to public health but also rejected the argument that the General Clause prohibited police action to protect the individual. See, e.g., Judgment of Mar. 2, 1905, Preuss. Oberverwaltungsgericht, Ger., 4 NOISE HANDBOOK, *supra* note 2, ¶ 50,233 (II.402); Judgment of Apr. 30, 1906, Preuss. Oberverwaltungsgericht, Ger., 4 NOISE HANDBOOK, *supra* note 2, ¶ 50,235 (III A 78.03); Judgment of Feb. 24, 1907, Preuss. Oberverwaltungsgericht, 4 NOISE HANDBOOK, *supra* note 2, ¶ 50,237 (III C 110.06).

30. Strassenverkehrsgesetz (Motor Vehicle Law), Dec. 19, 1952, [1952] BGBl I 837, as amended by Law of Aug. 6, 1975, [1975] BGBl I 2121 [hereinafter cited as StVG]. Selected excerpts are reprinted in 2 NOISE HANDBOOK, *supra* note 2, ¶ 30,025.

31. Strassenverkehrs-Ordnung (Motor Vehicle Ordinance), Nov. 16, 1970, [1970] BGBl I 1565 [hereinafter cited as StVO]. Selected excerpts are reprinted in 2 NOISE HANDBOOK, *supra* note 2, ¶ 30,030.

32. Allgemeine Verwaltungsvorschrift zur Strassenverkehrs-Ordnung (Motor Vehicle Regulations), Nov. 24, 1970, [1970] Bundesanzeiger [BAnz] Nr. 228 Supp. [hereinafter cited as Regulations]. Selected excerpts are reprinted in 2 NOISE HANDBOOK, *supra* note 2, ¶ 30,030.

33. Allgemeine Verwaltungsvorschrift für die Erteilung einer Verwarnung (General Administrative Regulations Governing the Issuance of a Warning), Dec. 13, 1968, [1968] BAnz Nr. 235, as amended by Regulations of Feb. 19, 1971, [1971] BAnz Nr. 36

Ministry of Transportation Guidelines Governing Primary Testing Under Annex VIII to the StVZO (Primary Test Guidelines),<sup>35</sup> the Ministry of Transportation Guidelines Governing Intermediate Testing Under Annex VIII to the StVZO (Intermediate Test Guidelines),<sup>36</sup> the Ministry of Transportation Regulations Governing the Replacement of Motor Vehicle Mufflers (Muffler Replacement Regulations),<sup>37</sup> the Motor Vehicle Noise Emission Measurement Guidelines (German Noise Emission Guidelines),<sup>38</sup> the Ministry of Transportation Guidelines Governing Close-Range Stationary Measurements Under Annex VIII to the StVZO (Close-Range Stationary Measurement Guidelines),<sup>39</sup> and the Ministry of Transportation Guidelines Governing Traffic Measures to Protect Sleep (Guidelines to Protect Sleep).<sup>40</sup> Most of these laws, ordinances, regulations, and guidelines embody the principle of causation. The party who directly and, in some cases,

---

[hereinafter cited as Warning Regulations]. Selected excerpts are reprinted in 2 NOISE HANDBOOK, *supra* note 2, ¶ 30,030.

34. Strassenverkehrs-Zulassungs-Ordnung (Motor Vehicle Approval Ordinance), Nov. 15, 1974, [1974] BGBl I 3193 [hereinafter cited as StVZO]. Selected excerpts are reprinted in 2 NOISE HANDBOOK, *supra* note 2, ¶ 30,031.

35. Richtlinie des Bundesministers für Verkehr betr. die Durchführung von Hauptuntersuchungen an Fahrzeugen nach Anlage VIII zur StVZO (Ministry of Transportation Guidelines Governing Primary Testing Under Annex VIII to the StVZO), Apr. 5, 1972, [1972] Verkehrsblatt [VkB] 192 [hereinafter cited as Primary Test Guidelines], reprinted in 2 NOISE HANDBOOK, *supra* note 2, ¶ 30,034.

36. Richtlinie des Bundesministers für Verkehr für die Durchführung von Zwischenuntersuchungen an Fahrzeugen nach Anlage VIII StVZO (Ministry of Transportation Guidelines Governing Intermediate Testing Under Annex VIII to the StVZO), Apr. 5, 1972, [1972] VkB 195 [hereinafter cited as Intermediate Test Guidelines], reprinted in 2 NOISE HANDBOOK, *supra* note 2, ¶ 30,041.

37. Erlass des Bundesministers für Verkehr über Austausch von Schalldämpfern an Kraftfahrzeugen (Ministry of Transportation Regulations Governing the Replacement of Motor Vehicle Mufflers), July 10, 1956, [1956] VkB 538 [hereinafter cited as Muffler Replacement Regulations], reprinted in 2 NOISE HANDBOOK, *supra* note 2, ¶ 30,040.

38. Richtlinien für die Geräuschmessung an Kraftfahrzeugen (Motor Vehicle Noise Emission Measurement Guidelines), Sept. 13, 1966, [1966] VkB 531 [hereinafter cited as German Noise Emission Guidelines], reprinted in 2 NOISE HANDBOOK, *supra* note 2, ¶ 30,035.

39. Richtlinie des Bundesministers für Verkehr für die Messung des Standgeräusches von Kraftfahrzeugen im Nahfeld im Rahmen der obligatorischen Überwachung nach § 29 StVZO und der Anlage VIII StVZO (Ministry of Transportation Guidelines Governing Close-Range Stationary Measurements Under Annex VIII to the StVZO), Dec. 16, 1976, [1976] Amtsblatt für das Post- und Fernmeldewesen 1000 [hereinafter cited as Close-Range Stationary Measurement Guidelines], reprinted in 2 NOISE HANDBOOK, *supra* note 2, ¶ 30,037.

40. Richtlinien des Bundesministers für Verkehr für Strassenverkehrsrechtliche Massnahmen zum Schutz der Nachtruhe (Ministry of Transportation Guidelines Governing Traffic Measures to Protect Sleep), May 29, 1974, [1974] VkB 363 [hereinafter cited as Guidelines to Protect Sleep], reprinted in 2 NOISE HANDBOOK, *supra* note 2, ¶ 30,033.

indirectly causes noise is responsible for minimizing its impact and for bearing whatever costs may be associated with the measures necessary to minimize its impact.<sup>41</sup>

The other source for noise emission standards is found in directives adopted by the European Economic Community (EEC), of which the Federal Republic of Germany is a member state.<sup>42</sup> Since EEC directives either modify or supersede national law, no discussion of motor vehicle noise law in the Federal Republic of Germany would be complete without discussing the "General Programme" for removing technical barriers to trade in the EEC that was adopted by the Council of European Communities (Council)<sup>43</sup> on May 29, 1969.

One aspect of the General Programme called for the development of common technical standards that would harmonize the existing technical standards within the EEC.<sup>44</sup> The initial aim of harmonization "was simply to ensure that the 'finished product' could circulate freely throughout the Common Market."<sup>45</sup> In the

---

41. SCHRIFTENREIHE DES BUNDESMINISTERIUMS DES INNERN, UMWELTPLANUNG: MATERIALIEN ZUM UMWELTPROGRAMM DER BUNDESREGIERUNG (Environmental Planning: Materials for the Environmental Program of the Federal Government) 227 (1971) [hereinafter cited as ENVIRONMENTAL PLANNING].

42. There are nine members of the EEC: Belgium, Denmark, the Federal Republic of Germany, France, Ireland, Italy, Luxembourg, the Netherlands, and the United Kingdom.

43. The Council of the European Communities consists of representatives of the governments of the nine member states. A foreign minister is his country's main representative. However, Council meetings are frequently attended by ministers of agriculture, transportation, finance, and industry, who sometimes attend with the foreign minister and sometimes attend on their own, depending on the subject matter being considered by the Council.

44. For a discussion of the aspect of the "General Programme" that calls for the development of common technical standards of motor vehicles, see COMMISSION OF THE EUROPEAN COMMUNITIES, INFORMATION NO. 84, HARMONIZATION OF THE TECHNICAL CHARACTERISTICS OF MOTOR VEHICLES (1975) [hereinafter cited as VEHICLE HARMONIZATION].

The first common technical standards were adopted by the Council in 1970 and appeared in 1971 motor vehicle models. EUROPEAN COMMUNITY NEWSFEATURE, Jan. 17, 1975, at 2. A succeeding generation of common technical standards reached the Council by the end of 1975. Some were adopted in 1976 and appeared in 1977 or 1978 motor vehicle models.

45. VEHICLE HARMONIZATION, *supra* note 44, at 1. Before the Treaty of Rome, "free movement" of newly manufactured products was hampered by quotas, customs duties, and a variety of technical standards. Quotas and customs duties automatically disappeared pursuant to the general provisions of the Treaty of Rome. Technical standards, however, had to be harmonized. Even minor differences in manufacturing standards constituted awkward impediments. These differences required every manufacturer to adapt his production line to the requirements in force in the country to which he wished to export his product. These differences also caused distortions to competition because manufacturers had to charge higher prices to cover the higher costs resulting from meeting standards that were stringent in some countries and less stringent in other countries. *Id.*

intervening years, however, another aim—environmental action—has assumed increasing importance. The Commission of the European Communities (Commission)<sup>46</sup> submitted its “First Programme on Environmental Action” to the Council on April 17, 1973.<sup>47</sup> Noise in general and traffic noise in particular did not receive specific attention in the First Programme on Environmental Action.<sup>48</sup> This oversight was corrected in the “Second Programme on Environmental Action,” submitted to the Council on March 24, 1976, which articulates EEC environmental policy for the period 1977-1981.<sup>49</sup> One whole chapter of the Second Programme on Environmental Action is devoted to noise.<sup>50</sup>

The aim of the environmental action program is to improve the quality of life by “[improving] road safety, [contributing] to the conservation of the natural environment, and [protecting] the citizens of Europe against noise and disturbance.”<sup>51</sup> Since

---

46. The Commission of the European Communities is the executive branch of the EEC. In this capacity, the Commission is the guardian of the Treaty of Rome, initiates EEC policy, and acts as the exponent of EEC interests before the Council.

The Commission consists of 13 members who are appointed by the member states. These members are independent of their own governments and the Council. The Council cannot remove a member of the Commission. In its discretion, the European Parliament can compel the Commission to resign as a body by passing a vote of censure.

47. European Communities Commission Background Note, at 3 (Mar. 15, 1976). After receiving the First Programme on Environmental Action, the Council adopted a supplement to the General Programme on May 21, 1973.

48. Bentil, *Environmental Improvement through Noise Control in the European Community* 1978 J. PLAN. & ENV'T'L L. 16. The First Programme on Environmental Action did articulate certain general principles: (1) “the best protection of the environment [consists] in preventing at [the] source the creation of pollution or nuisances”; (2) “the effects of various activities on the environment should be taken into account at the earliest possible opportunity in the technical processes of planning and decision-making”; (3) “the cost of preventing and abolishing nuisances must be borne by the polluter”; and (4) “environmental policies should be harmonized in the Community and . . . national programmes in that direction should be co-ordinated with those of the Community on the basis of a common long-term plan.” *Id.*

49. The goal of the Second Programme on Environmental Action is “to improve the quality of life . . . without compromising economic revival.” EUROFORUM, Dec. 21, 1976, annex 2, at 1. Most of the budget for the Second Programme on Environmental Action is earmarked for research.

50. EUROFORUM, Oct. 11, 1977, annex 2, at 1.

51. VEHICLE HARMONIZATION, *supra* note 44, at 1-2. As the aims of harmonization have broadened, certain member states who cherish their traditions and independence have accused the Commission of the European Communities of having a mania for harmonization and of attempting to standardize everything manufactured in the EEC. This accusation was sufficiently serious that the Commission of the European Communities reviewed its position and responded as follows in November 1974:

The outcome of these reflections has been that the Commission will in future follow in this area in particular a less uniformist approach. The Commission will in its work towards the realization of a common internal market ensure that

1973 the EEC has allocated more than forty-three million units of account<sup>52</sup> to its environmental action program.<sup>53</sup> Expenditures in 1977 were more than four times greater than 1973 expenditures.<sup>54</sup>

The procedure whereby the EEC adopts and the member states implement common technical standards is protracted and complex. After initial preparatory work by experts, the Commission approves a proposed common technical standard for presentation to the Council. The Council then consults the European Parliament<sup>55</sup> and the Economic and Social Committee<sup>56</sup> for their opinions, a process which takes a year. The proposed common technical standard then comes back to the Council where a unanimous decision is necessary in order to adopt the standard by means of a Council directive. When a directive containing a common technical standard is adopted, the standard becomes EEC law. The procedure, however, is not complete. Time must be allowed for industry to comply with the standard and for the legislatures in the member states to incorporate the standard into their national laws. This final step takes approximately eighteen months.

The EEC has attempted to solve two distinct but interrelated problems by harmonizing the technical standards for motor vehicles. One apparent problem concerned technical standards

---

wherever possible autonomy is left in the hands of national authorities. National legislation will not be harmonized for the sake of uniformity but only when essential for the creation of the internal market and only to the extent necessary to fulfill that goal . . . . The Commission is of the opinion that the citizens of Europe do not wish to sacrifice their local customs and traditions for the mere sake of uniformity in the common market.

*Id.* at 3.

52. One unit of account equals  $\pm$  \$1.20.

53. EUROFORUM, Apr. 11, 1978, at 5. Most of the 43 million units of account were devoted to research activities.

54. *Id.* Environmental expenditures not only improve the environment, they also create jobs, thereby reducing structural unemployment problems. One recent study by two German specialists concluded that DM 50 million/\$25 million could be spent on noise reduction projects throughout the EEC and that such an expenditure would create 605 man-years of employment. EUROFORUM, Mar. 21, 1978, annex 1, at 1, 3.

55. The European Parliament consists of 410 members who represent the 260 million people living in the EEC. Members, who were formerly appointed, are now elected. The first election took place on June 7-10, 1979. There are 81 members each from the Federal Republic of Germany, France, Italy, and the United Kingdom; 25 from the Netherlands; 24 from Belgium; 16 from Denmark; 15 from Ireland; and 6 from Luxemborg. Simon Veil of France was elected President at the first session of the elected Parliament.

56. The Economic and Social Committee consists of 144 members. These members are representatives of various sectors of economic and social life, *e.g.*, trade associations, unions, and farmers, and assist the Council and the Commission on Common Market and Euratom matters.

that were mandatory in each member state but which differed from member state to member state. These differences impeded the free circulation of products.<sup>57</sup> A more subtle problem involved approval procedures established by the member states to ascertain compliance with the technical standards. These approval procedures usually involved "type-approval," *i.e.*, checking motor vehicles by type before models of that type could be placed on the market. Since the approval procedures themselves differed from member state to member state, manufacturers were unable to complete certificates of conformity valid throughout the EEC. The member states, moreover, encountered difficulties in exchanging information. Each member state was reluctant to accept type-approval certificates from another member state.

The EEC has responded to the problem of differing technical standards by adopting a series of directives.<sup>58</sup> Five of these directives are relevant to the discussion of noise regulation: the Directive "on the approximation of the laws of the Member States relating to the permissible sound level and the exhaust system of motor vehicles" (EEC Noise Emission Directive),<sup>59</sup> the Directive "adapting to technical progress the Council Directive of 6 February 1970 on the approximation of the laws of the Member States relating to the permissible sound level and the exhaust system of motor vehicles" (Exhaust System Amendment),<sup>60</sup> the Directive "amending Directive 70/15 EEC relating to the permissible sound level and the exhaust system of motor vehicles" (Permissible Sound Level Amendment),<sup>61</sup> the Directive "on the approximation of the laws of the Member States relating to the doors of motor vehicles and their trailers" (Door Directive),<sup>62</sup> and the Directive "on the approximation of the laws of the Member States relating to audible warning devices for motor vehicles" (Warning Device Directive).<sup>63</sup> The EEC has responded to the

57. VEHICLE HARMONIZATION, *supra* note 44, at 1.

58. As of Oct. 14, 1977, for example, the Council had adopted 38 different directives dealing with technical standards for motor vehicles. EUROPEAN ECONOMIC COMMUNITY TRADE AND INDUSTRY, Oct. 14, 1977, at 80.

59. 13 J.O. COMM. EUR. (No. L 42) 16 (1970) (English version at 1970(I) O.J. EUR. COMM. 111 (Spec. ed. 1972)) [hereinafter cited as EEC Noise Emission Directive].

60. 16 O.J. EUR. COMM. (No. L 321) 33 (1973) [hereinafter cited as Exhaust System Amendment].

61. 20 O.J. EUR. COMM. (No. L 66) 33 (1977) [hereinafter cited as Permissible Sound Level Amendment].

62. 13 J.O. COMM. EUR. (No. L 176) 5 (1970) (English version at 1970(II) O.J. EUR. COMM. 564 (Spec. ed. 1972)) [hereinafter cited as Door Directive].

63. 13 J.O. COMM. EUR. (No. L 176) 12 (1970) (English version at 1970(II) O.J. EUR. COMM. 571 (Spec. ed. 1972)) [hereinafter cited as Warning Device Directive].

problem of approval procedures by adopting two directives: the Directive "on the approximation of the laws of the Member States relating to the type-approval of motor vehicles and their trailers" (Type-Approval Directive)<sup>64</sup> and the Directive "on the approximation of the laws of the Member States relating to roadworthiness tests for motor vehicles and their trailers" (Roadworthiness Directive).<sup>65</sup>

Before analyzing the second phase of German traffic noise law, a cautionary note should be sounded. Noise emission standards are an incomplete solution to the problem of traffic noise. As German officials have recognized, "[T]he state cannot be satisfied with merely enacting modern noise laws . . . [but] will also have to make clear by other political—including financial—measures that noise has been given high priority."<sup>66</sup>

### 1. Motor Vehicle Law (StVG)

The StVG consists of thirty sections. Section 1 provides that "motor vehicles<sup>67</sup> will not be permitted to operate on public highways or in public places until they comply with the approval procedures established by authorized officials . . ."<sup>68</sup> The Minister of Transportation,<sup>69</sup> acting alone or in conjunction with the Minister of the Interior,<sup>70</sup> and subject in some cases to the concurrence of the Bundesrat,<sup>71</sup> is authorized by section 6 to issue

64. 13 J.O. COMM. EUR. (No. L 42) 1 (1970) (English version at 1970(I) O.J. EUR. COMM. 96 (Spec. ed. 1972)) [hereinafter cited as Type-Approval Directive].

65. 20 O.J. EUR. COMM. (No. L 47) 47 (1977) [hereinafter cited as Roadworthiness Directive].

66. ENVIRONMENTAL PLANNING, *supra* note 41, at 227.

67. As the term is used in the StVG, "motor vehicles" include "agricultural vehicles that are powered by an engine but do not run on a track." StVG, *supra* note 30, § 1(2).

68. *Id.* § 1(1). Exceptions to the approval standards are possible and are to be determined by the Minister of Transportation. In the case of motor vehicles manufactured in the Federal Republic of Germany, the Minister of Transportation can make approval dependent upon manufacturing standards.

69. Bundesminister für Verkehr.

70. Bundesminister des Innern. Regulations issued pursuant to § 6(1)(5)(a)-(b) and 6(1)(7) of the StVG, provided they are based on measures taken pursuant to § 6(1)(5)(a) or (b) of the StVG, must be jointly issued by the Minister of Transportation and the Minister of Interior. StVG, *supra* note 30, § 6(2).

71. Regulations relating to constructing, equipping, and testing motor vehicles or prohibiting harmful environmental effects as that term is used in the Federal Ambient Levels Protection Law no longer require the concurrence of the Bundesrat. Compare StVG, *supra* note 30, § 6(1), with § 70(1)(3)(3) of the Federal Ambient Levels Protection Law, Gesetz zum Schutz vor schädlichen Umwelteinwirkungen durch Luftverunreinigungen, Geräusche, Erschütterungen und ähnliche Vorgänge (Bundes-Immissionsschutzgesetz) (Federal Ambient Levels Protection Law), Mar. 15, 1974,



regulations and administrative directives with respect to measures guarding against disturbances caused by traffic noise; measures relating to constructing, equipping and testing motor vehicles; measures prohibiting against harmful environmental effects as that term is used in the Federal Ambient Levels Protection Law;<sup>72</sup> and measures fulfilling the Federal Republic's agreements with the EEC.<sup>73</sup>

Section 24 declares that "whoever, intentionally or negligently, violates a regulation issued pursuant to Section 6(1) through 6(6), provided that regulation imposes a penalty for that act, has committed an administrative offense."<sup>74</sup> Such offenses can be punished with a fine.<sup>75</sup> Violations of section 24 may be major, *i.e.*, "gross or persistent," or minor. If the violation is "gross or persistent," section 25 authorizes a fine and permits appropriate officials or a court to prohibit the individual from driving any or a particular type of vehicle for a period of one to three months.<sup>76</sup>

If the violation is minor and uniform treatment is desirable, either because of its nature or its frequency, section 27 authorizes a warning fine of up to DM 40.<sup>77</sup> Section 27 also authorizes the Minister of Transportation, subject to the concurrence of the Bundesrat, to issue warning regulations<sup>78</sup> to cover such violations.<sup>79</sup> These warning regulations must define in what situations and under what conditions a warning will be issued.<sup>80</sup> They must also specify the amount of the fine to be imposed.<sup>81</sup>

---

[1974] BGBl I 721, as amended by Law of Aug. 15, 1974, [1974] BGBl I 1942 [hereinafter cited as BImSchG], reprinted in 2 NOISE HANDBOOK, *supra* note 2, ¶ 35,025.

72. StVG, *supra* note 30, § 6(1).

73. StVG, *supra* note 30, § 6(1). Section 70(1)(2) of the Federal Ambient Levels Protection Law StVG, *supra* note 30, § 6(1) amended StVG § 6(1) by adding subsecs. 5(a), 5(b), and (7).

74. StVG, *supra* note 30, § 24(1). If a regulation was issued prior to Jan. 1, 1969, the penalty requirement is waived.

75. *Id.* § 24(2).

76. *Id.* § 25(1).

77. *Id.* § 27(1).

78. See Warning Regulations, *supra* note 33.

79. StVG, *supra* note 30, § 27(2).

80. The Warning Regulations may also define those situations and circumstances where there is no necessity to issue a warning. A warning can be dispensed with if the violation constitutes either a serious danger to the other motorists or gross or reckless behavior. Even in such cases, however, a warning can be issued under "special circumstances." *Id.* § 27(3).

81. *Id.* § 27(2).

## 2. Motor Vehicle Ordinance (*StVO*)

The *StVO* was issued in response to the authorization contained in section 6(1) of the *StVG*. The *StVO* became effective on March 1, 1971,<sup>82</sup> and is divided into three parts.<sup>83</sup>

Part I of *StVO* is entitled "General Traffic Rules"<sup>84</sup> and consists of thirty-five sections. Military, police, emergency, and customs personnel are exempt from the rules found in part I, provided they are performing official duties.<sup>85</sup> If military necessity requires such an exemption, North Atlantic Treaty Organization (NATO) troops are also exempt.<sup>86</sup>

According to the Motor Vehicle Regulations, which supplement the *StVO*, "the *StVO* circumscribes and regulates traffic on public highways."<sup>87</sup> The Regulations define "public highways" to include streets used as public highways and to exclude streets that otherwise might be considered public highways but are not in use.<sup>88</sup> Under articles 72(1) and 74(22) of the West German Constitution, state law does not govern vehicles.<sup>89</sup> Local traffic rules, moreover, must be consistent with the *StVO*.<sup>90</sup>

Multitone warning devices are prohibited by section 16.<sup>91</sup> Warning devices may be sounded or lights may be flashed only when a motorist is overtaking another motorist outside community limits or when a motorist sees himself or another individual endangered.<sup>92</sup> The Warning Regulations specify a warning fine of DM 5 for violations of section 16.<sup>93</sup>

Section 22 of the *StVO* regulates the loading of motor vehicles. Every effort must be made when loading a vehicle to ensure that the goods are loaded so that they will travel in safety, will

82. *StVO*, *supra* note 31, § 53.

83. Since pt. II of the *StVO*, consisting of §§ 36-43, is only indirectly concerned with noise, there will be no discussion of it.

84. Allgemeine Verkehrsregeln.

85. *StVO*, *supra* note 31, § 35(1).

86. *Id.* § 35(2). Section 35(2) further provides that NATO troops are freed from the prohibition against racing in § 29 of the *StVO* to the extent that special regulations or agreements exist.

87. Regulations, *supra* note 32, § 1(I).

88. *Id.* § 1(II). A public highway may cease to be a street because of construction or because its use is no longer open to all motor vehicles.

89. *Id.* § 1(III).

90. *Id.*

91. *StVO*, *supra* note 31, § 16(3). See Judgment of Mar. 4, 1966, Bundesverwaltungsgericht, W. Ger., 4 NOISE HANDBOOK, *supra* note 2, ¶ 50,226 (-IV C-2.65-).

92. *StVO*, *supra* note 31, § 16(1).

93. Warning Regulations, *supra* note 33, § 3(I)(16/16.2). DM 5 is approximately \$2.50.

not be dislodged during transport, and will not cause unreasonable noise.<sup>94</sup>

Racing is prohibited by section 29.<sup>95</sup> The Regulations both strengthen and weaken this prohibition. They weaken the prohibition by limiting it to nonorganized racing<sup>96</sup> and strengthen it by defining "racing" to include races where the participants do not start at the same time.<sup>97</sup>

A permit is necessary for events requiring greater than normal use of highways. This requirement applies whenever the use of the street is limited because of the number of vehicles, the behavior of their operators, or the manner in which the vehicles are operated.

All unnecessary noise resulting from the operation of a vehicle, such as closing doors too loudly or unnecessary idling, is prohibited by section 30. Unnecessary driving within community limits is prohibited if others are disturbed by this activity. The Regulations amplify these prohibitions by establishing five categories of activities that cause unnecessary noise: (1) unnecessary idling, (2) revving the motor of an empty vehicle or a vehicle in low gear, (3) unnecessary acceleration, (4) high speed turns, and (5) loud closing of doors, hood, or trunk of a vehicle.<sup>98</sup> Warning fines of DM 10 can be assessed for violations of the unnecessary noise prohibition.<sup>99</sup>

The StVO requires the issuance of a permit for vehicular activities that could disturb people who are sleeping.<sup>100</sup> The Regulations define nighttime as the period from 10:00 p.m. to 6:00 a.m.<sup>101</sup> The Regulations also indicate that all vehicular activities are subject to the permit requirement, except those taking place far from areas of human habitation and involving only a few vehicles.<sup>102</sup> Before determining whether a permit should be granted, the Regulations require that the police and the affected community be consulted.<sup>103</sup>

The operation of trucks whose gross weight exceeds 7.5 tons

94. StVO, *supra* note 31, § 22(1).

95. *Id.* § 29(1).

96. Regulations, *supra* note 32, § 29(1)(I).

97. *Id.* § 29(1)(II).

98. *Id.* § 30(1).

99. Warning Regulations, *supra* note 33, § 3(I)(24). DM 10 is approximately \$5.

100. StVO, *supra* note 31, § 30(2).

101. Regulations, *supra* note 32, § 30(2)(I).

101. StVO, *supra* note 31, § 30(2).

102. *Id.* § 30(2)(II).

103. *Id.* § 30(2)(III).

is prohibited on Sundays and holidays from midnight until 10:00 p.m.<sup>104</sup> There are twelve such holidays: New Year's Day, Good Friday, Easter Monday, May 1st, Ascension Day, Whitmonday, Corpus Christi, June 17th, All Saints Day, Day of Prayer and Repentance, Christmas Day, and the Day Following Christmas.

Operating loudspeakers, offering goods or services of any kind for sale on or near highways, or using a form of advertisement<sup>105</sup> or propaganda<sup>106</sup> outside community limits<sup>107</sup> is prohibited by section 33 if the attention of motorists could be diverted or if they could be disturbed in a way that could endanger or hinder traffic.<sup>108</sup> The Regulations go one step further and state unequivocally that "loudspeakers always hinder traffic."<sup>109</sup>

Part III of the StVO contains the enforcement provisions and consists of nine sections. The question of jurisdiction is addressed by two different sections. Section 44 discusses subject matter jurisdiction. State highway department officials<sup>110</sup> have the primary responsibility of enforcing the StVO.<sup>111</sup> Since state highway department officials are midlevel officials, higher administrative officials<sup>112</sup> or the highest state officials<sup>113</sup> can either direct these midlevel officials to take certain measures or can take the measures themselves.<sup>114</sup>

The permits required by sections 29 and 30 are usually granted by state highway department officials.<sup>115</sup> If the nature of the activity requiring a permit exceeds the territorial jurisdiction of state highway department officials, higher administrative officials can grant the permit. The highest state officials can grant a

104. StVO, *supra* note 31, § 30(3). Certain vehicles that might otherwise fall within this prohibition are exempted by the Regulations. For example, vehicles whose sole purpose is to pull motor vehicles and motor vehicles that are used for display purposes are exempt from the prohibition against Sunday and holiday operation. Regulations, *supra* note 32, § 30(3).

105. The prohibition against advertising found in the StVO includes driving or parking a motor vehicle for purposes of advertisement. StVO, *supra* note 31, § 33(1)(3).

106. Four forms of advertisement or propaganda are mentioned in the StVO: pictures, writing, film, and sound. *Id.*

107. The prohibition against advertisement or propaganda outside community limits applies to advertisement or propaganda that originates within community limits but affects or could affect traffic outside community limits. *Id.*

108. *Id.* § 33(1).

109. Regulations, *supra* note 32, § 33(1)(1).

110. Strassenverkehrsbehörde.

111. StVO, *supra* note 31, § 44(1).

112. Höhere Verwaltungsbehörde.

113. Oberste Landesbehörde.

114. StVO, *supra* note 31, § 44(1). Directions may be given with respect to individual cases.

115. *Id.* § 44(3).

permit when the nature of the activity exceeds the territorial jurisdiction of higher administrative officials. Higher administrative officials and the highest state officials are free, however, to delegate this authority if the applicable state law permits such delegation. If an activity will affect more than one state, the highest state officials of the state where the activity originates can grant the permit.<sup>116</sup>

Section 47 of the StVO discusses territorial jurisdiction. The state highway department officials possessing territorial jurisdiction in most cases are the state highway department officials for the district where an exception is allowed or where a permit is granted.<sup>117</sup> Special rules have been formulated for situations involving loading. State highway department officials for the district where the vehicle is loaded are responsible not only for the actual loading of the vehicle but also for the trip to the loading area.<sup>118</sup> Special rules have also been developed for situations involving an unlimited number of trips during a limited time period under a permit. State highway department officials for the district where the permit holder lives, has his major place of business, or has any place of business are responsible.<sup>119</sup>

State highway department officials are authorized by section 45 to limit or prohibit the use of a particular highway.<sup>120</sup> Such limitations or prohibitions are routinely imposed to ensure safety and order, to complete repairs, and to prevent extraordinary damage to a highway.<sup>121</sup> They can also be imposed to protect sleep in residential areas and to maintain the peace in other areas deserving of protection from noise.<sup>122</sup> Areas near hospitals and convalescent homes and areas outside community limits set aside primarily for purposes of recuperation and relaxation<sup>123</sup> are examples of areas deserving such protection.<sup>124</sup>

The Regulations establish certain procedures that must be followed before the use of a highway can be limited or prohibited pursuant to section 45. Before such a decision is made, state

---

116. *Id.*

117. *Id.* § 47(2)(3).

118. *Id.* § 47(2)(4).

119. *Id.* § 47(2)(3).

120. *Id.* § 45(1).

121. *Id.*

122. *Id.*

123. Nature parks are an example of an area that is set aside primarily for purposes of recuperation and relaxation. Regulations, *supra* note 32, § 45(1)(VII).

124. StVO, *supra* note 31, § 46(1).

highway construction department officials<sup>125</sup> and the police must be consulted.<sup>126</sup> "Other officials" may also be consulted.<sup>127</sup> All reasonable detours must be considered.<sup>128</sup> If the limitation or prohibition is being imposed to protect sleep in a residential area, the Regulations also require state highway department officials to obtain the concurrence of the highest state officials from whom the power has been delegated,<sup>129</sup> provided the highest state officials have not waived this requirement.<sup>130</sup>

Section 46 authorizes exceptions to the StVO. Depending on the nature of the exception sought, state highway department officials, the highest state officials, or the Minister of Transportation are authorized to grant exceptions. State highway department officials, for example, may grant exceptions to the prohibitions against the operation of trucks on Sundays<sup>131</sup> and the use of loudspeakers.<sup>132</sup> These exceptions are limited to individual cases or to particular categories<sup>133</sup> and are difficult to obtain. The Regulations state that "an exception should be granted only in cases where particularly urgent situations have been established."<sup>134</sup> With respect to loudspeakers, the standard is whether "a predominate community interest" justifies granting an exception.<sup>135</sup>

The highest state officials or the party to whom the power has been delegated may grant exceptions to any provision of the StVO.<sup>136</sup> If an exception would affect more than one state, the Minister of Transportation may grant it.<sup>137</sup> He, however, is subject to the absolute prohibition against nonorganized racing found in section 29.<sup>138</sup>

Exceptions or permits can be granted subject to withdrawal, stated conditions, time limitations, or fees.<sup>139</sup> If expert opinion is

125. Strassenbaudehörde.

126. Regulations, *supra* note 32, § 45(1)(I).

127. *Id.* The Regulations do not suggest that the general public be consulted.

128. *Id.* § 45(1)(II).

129. *Id.* § 45(1)(V). Measures to protect sleep in residential areas are the only measures that require the concurrence of higher authorities before they can be implemented.

130. *Id.* § 45(1)(VI).

131. StVO, *supra* note 31, § 46(1)(7).

132. *Id.* § 46(1)(9).

133. *Id.* § 46(1).

134. Regulations, *supra* note 32, § 46(I). The Regulations provide that an exception is fatally defective unless the grant of the exception specifically states the reasons for and justification of the action taken.

135. *Id.*

136. StVO, *supra* note 31, § 46(2).

137. *Id.*

138. *Id.*

139. *Id.* § 46(3).

required as a precondition to the grant of an exception or permit, the cost of preparing the opinion must be borne by the party seeking the exception or permit.<sup>140</sup>

Section 49 lists the acts which constitute an administrative offense under the StVO. An individual violates section 24 of the StVG if he either intentionally or negligently violates any of the following provisions of the StVO: (1) section 1(2) (general behavior in traffic), (2) section 16 (warning devices), (3) section 22 (loading), (4) section 30(1), (2), and (3) (unnecessary noise and prohibition against Sunday and holiday operation of trucks), and (5) section 33 (operating loudspeakers, offering goods or services, using advertisement or propaganda).<sup>141</sup> In addition, a motorist who either intentionally or negligently participates in a race as prohibited by section 29 violates section 24 of the StVG.<sup>142</sup>

### 3. *Motor Vehicle Approval Ordinance (StVZO)*

The StVZO consists of seventy-two sections divided into three chapters. Chapter B, entitled "Motor Vehicles,"<sup>143</sup> and chapter C, entitled "Enforcement, Fines and Miscellaneous Provisions,"<sup>144</sup> are relevant to the discussion of German traffic noise law. In contrast, chapter A, entitled "People,"<sup>145</sup> is not relevant and will not be discussed.

Chapter B is divided into three parts. The general rules governing the approval process for motor vehicles<sup>146</sup> are described in part I, which consists of two sections. "All motor vehicles," according to section 16, "which comply with the provisions of the StVO and the StVZO are entitled to use public highways, provided they are not of a type which is subject to a special permit procedure."<sup>147</sup> The term "motor vehicle," however, does not include "[t]oboggans, baby carriages, scooters and similar means of locomotion."<sup>148</sup>

Section 17 then outlines what actions can be taken in cases involving either noncompliance or reasonable doubt as to compli-

140. *Id.*

141. *Id.* § 49(1). A warning fine of DM 10/\$5 can be assessed for producing unreasonable noise. Warning Regulations, *supra* note 33, § 3(I)(24). In more serious cases, an even higher fine can be assessed.

142. StVO, *supra* note 31, § 49(2).

143. Fahrzeuge.

144. Durchführungs-, Bussgeld- und Schlussvorschriften.

145. Personen.

146. Zulassung von Fahrzeugen im allgemeinen.

147. StVZO, *supra* note 34, § 16(1).

148. *Id.* § 16(2).

ance. If a vehicle does not comply with the StVZO, the appropriate administrative officials can set a time limit within which the owner or operator must correct the defect. They may also limit or prohibit the use of the motor vehicle.<sup>149</sup> If there is simply reasonable doubt as to compliance with the StVZO, two courses of action are available to the appropriate administrative officials. They can require the owner or operator to obtain a report stating that the vehicle complies with the StVZO,<sup>150</sup> or they can require the owner or operator to produce the motor vehicle for testing purposes.<sup>151</sup>

Part II, consisting of twelve sections, outlines the approval procedure through which a motor vehicle must pass in order to obtain or retain an operating permit.<sup>152</sup> The approval procedure consists of an initial test at the time the vehicle is manufactured or first enters traffic in the Federal Republic of Germany and periodic testing thereafter throughout the useful life of the vehicle.

Section 18 describes those vehicles subject to and those exempt from the approval procedures. As a general rule, "[m]otor vehicles with a maximum speed which exceeds 6 km/h [4 mph] and their trailers" are subject to the approval procedures.<sup>153</sup> Small motorcycles with auxiliary motors are not subject to the approval procedures.<sup>154</sup> However, they may only be operated on public highways when an operating permit has been granted.<sup>155</sup>

In order to qualify for an operating permit, section 19 provides that the motor vehicle must comply with the StVZO, administrative directives issued pursuant thereto by the Minister of Transportation, and regulations implementing the Type-Approval Directive.<sup>156</sup> An operating permit continues to be valid throughout the useful life of the vehicle.<sup>157</sup>

---

149. *Id.* § 17(1).

150. *Id.* § 17(3)(1).

151. *Id.* § 17(3)(2).

152. Zulassungsverfahren für Kraftfahrzeuge und ihre Anhänger.

153. StVZO, *supra* note 34, § 18(1).

154. *Id.* § 18(2)(4).

155. *Id.* § 18(3). Certain categories of motorcycles are not even subject to the operating permit requirements: (1) motorcycles with auxiliary motors that first entered traffic before Jan. 1, 1957; (2) motorcycles with a maximum speed not in excess of 20 kmph/12 mph that first entered traffic before May 1, 1965; (3) small motorcycles and other vehicles treated as small motorcycles that were permanently located in the Saarland and that first entered traffic in the Saarland before Oct. 1, 1960; and (4) trailers that either cannot be towed at a speed in excess of 25 kmph/15 mph or that first entered traffic before Apr. 1, 1961. *Id.* § 18(3)(1)-(3).

156. *Id.* § 19(1).

157. *Id.* § 19(2).



Operating permits may be withdrawn<sup>158</sup> or may become invalid. Invalidity may result from operating the vehicle in such a way as to endanger other motorists<sup>159</sup> or from altering or removing<sup>160</sup> a part whose characteristics are prescribed.<sup>161</sup> If the operating permit becomes invalid because of alteration or removal, the owner or operator may avail himself of one of two options. He can supply the appropriate officials with a copy of the operating permit which a manufacturer has obtained for the new part or the part as modified.<sup>162</sup> Alternatively, he can supply the appropriate officials with an official report from an expert or an inspector indicating that the vehicle in its changed condition complies with applicable laws and regulations.<sup>163</sup>

In order to obtain an operating permit, a vehicle must successfully complete an initial test. This initial test can take one of three forms: a type test,<sup>164</sup> an individual vehicle test,<sup>165</sup> or a parts test.<sup>166</sup>

Section 20 permits a vehicle manufacturer guaranteeing the reliable performance of his product to conduct, at his own expense, a type test in order to secure a "general operating permit"<sup>167</sup> for all motor vehicles of that type.<sup>168</sup> A general operating permit can be granted to vehicles manufactured by one or a series of manufacturers.<sup>169</sup>

Not all vehicles in operation in the Federal Republic of Germany are manufactured by domestic manufacturers. If a motor vehicle is of foreign manufacture, a general operating permit can be secured by (1) the manufacturer or his agent if the motor vehicle is manufactured in the EEC, (2) the manufacturer's agent if the motor vehicle is not manufactured in the EEC but is imported into the Federal Republic of Germany from a country which is a member of the EEC, or (3) a dealer who is able to demonstrate that he is the sole supplier of a particular type of

---

158. *Id.*

159. *Id.*

160. Section 19(2) of the StVZO uses the word "change." However, its use suggests that the term comprehends removal as well as alteration.

161. StVZO, *supra* note 34, § 19(2).

162. *Id.* See notes 224-25 and accompanying text *infra*.

163. StVZO, *supra* note 34, § 19(2).

164. Typ Prüfung.

165. Einzelfahrzeug Prüfung.

166. Fahrzeugteile Prüfung.

167. Allgemeine Betriebserlaubnis. See note 186 and accompanying text *infra*.

168. StVZO, *supra* note 34, § 20(1).

169. *Id.*

vehicle within the Federal Republic of Germany.<sup>170</sup>

The Federal Office of Motor Vehicles (FOMV)<sup>171</sup> decides whether an application for a general operating permit will be granted.<sup>172</sup> The FOMV also determines what documentation must accompany the application.<sup>173</sup>

After a general operating permit has been granted, the recipient must prepare a "motor vehicle letter"<sup>174</sup> in a form approved by the FOMV<sup>175</sup> for each vehicle of the type covered by the general operating permit. The motor vehicle letter describes the characteristics of the vehicle.<sup>176</sup> If the grant of the operating permit is conditioned on an exception, the exception and the officials authorizing the exception must be identified.<sup>177</sup> The recipient(s) must also warrant the accuracy of the description of the motor vehicle and the compliance of the vehicle with the terms and conditions of the general operating permit.<sup>178</sup>

Deviations from the characteristics described in the motor vehicle letter are only allowed in two instances. A deviation is permissible if a revised general operating permit is obtained<sup>179</sup> or if the original general operating permit allows deviations of the kind that now exist and the original permit states that a revised permit is not required for deviations of that kind.<sup>180</sup>

General operating permits expire after a predetermined period of time, when withdrawn by the FOMV, or when the vehicle no longer complies with the terms and conditions of the permit.<sup>181</sup> The FOMV is empowered to withdraw a general operating permit when the recipient of the permit violates its provisions or demonstrates his unreliability, or when the motor vehicle type no longer satisfies the requirements of traffic safety.<sup>182</sup>

The FOMV can also require a manufacturer, his agent, or a dealer to demonstrate compliance with the terms and conditions

---

170. *Id.*

171. Kraftfahrt-Bundesamt.

172. StVZO, *supra* note 34, § 20(2).

173. *Id.*

174. Fahrzeugbrief.

175. StVZO, *supra* note 34, § 20(3).

176. If the motor vehicle is manufactured by a series of manufacturers, each manufacturer describes the characteristics of his product. *Id.*

177. *Id.*

178. *Id.*

179. *Id.* § 20(4).

180. *Id.*

181. *Id.* § 20(5).

182. *Id.*

of the general operating permit at any time.<sup>183</sup> The recipient of the general operating permit bears the costs associated with this verification if the FOMV discovers a violation.<sup>184</sup>

Since inconsistent type-approval procedures could impede the free flow of motor vehicles throughout the EEC, the Council of the European Communities adopted the Type-Approval Directive on February 6, 1970. The Type-Approval Directive consists of a preamble, sixteen articles divided into four chapters, and three annexes. Chapter I defines three terms. The term "vehicle" is defined in article 1 as "any motor vehicle intended for use on the road, with or without bodywork, having at least four wheels and a maximum design speed exceeding 25 km/h, and its trailers with the exception of vehicles which run on rails and of agricultural tractors and machinery."<sup>185</sup>

Article 2 defines "national type-approval." In the case of the Federal Republic of Germany, "allgemeine Betriebserlaubnis" is synonymous with "national type-approval."<sup>186</sup> The term, "'EEC type-approval' means the procedure whereby a member state certifies that a vehicle type satisfies the technical requirements of the separate Directives and the checks listed in the EEC type-approval certificate . . . ."<sup>187</sup>

EEC type-approval procedures are outlined in chapter II. Article 3 requires each manufacturer or his authorized representative to submit an application for EEC type-approval to a member state.<sup>188</sup> An information document accompanies the application.<sup>189</sup>

Article 4 mandates approval of the applicable motor vehicle type if the vehicle type conforms to the specifications in the information document and satisfies the checks in the type-approval certificate.<sup>190</sup> The member state granting the EEC type-approval has the responsibility to verify the compliance of production models with the approved prototype, acting, if necessary, in cooperation with the other member states.<sup>191</sup> Such verification is limited

183. *Id.* § 20(6).

184. *Id.*

185. Type-Approval Directive, *supra* note 64, art. 1.

186. *Id.* art. 2.

187. *Id.*

188. *Id.* art. 3. Annex II to the Type-Approval Directive contains a model EEC type-approval certificate. *Id.* annex II(B).

189. Manufacturers are prohibited from submitting an application for any type of motor vehicle to more than one member state. *Id.* art. 3.

190. *Id.* art. 4(1). Annex I to the Type-Approval Directive contains a model information document. *Id.* annex I.

191. *Id.* art. 4(2).

to spot checks. The member state granting the EEC type-approval must then complete all sections of the EEC type-approval certificate for each motor vehicle type approved.<sup>192</sup>

Article 5 imposes on the member state granting the EEC type-approval the duty to send other member states copies of the information document and the EEC type-approval certificate within one month after the member state grants or refuses to grant the EEC type-approval certificate.<sup>193</sup> If a type has been approved, "the manufacturer or his authorized representative in the country of registration shall complete a certificate of conformity . . . for each motor vehicle manufactured in conformity with the approved prototype."<sup>194</sup> Article 5 authorizes member states to request information not contained on the certificate of conformity, provided this information is being sought for taxation or registration purposes and provided the information is explicitly stated on the information document or can be derived from its contents.<sup>195</sup>

In order to satisfy the requirements of article 6, the member state granting the EEC type-approval must keep itself apprised of any discontinuances in the production of approved types or changes in the contents of the information document.<sup>196</sup> Major changes require the amendment of the existing certificate or the issuance of a new one.<sup>197</sup>

The member state issuing the EEC type-approval certificate must inform the manufacturer of its determination as to whether or not a change requires an amendment to the existing certificate<sup>198</sup> or the issuance of a new one.<sup>199</sup> If there is either a major change or a discontinuance in production, the member state issuing the new or amended EEC type-approval certificate or withdrawing an existing EEC type-approval certificate must send appropriate documentation<sup>200</sup> to the other member states within

---

192. *Id.*

193. *Id.* art. 5(1).

194. *Id.* art. 5(2).

195. *Id.* art. 5(3). Annex III to the Type-Approval Directive contains a model certificate of conformity. *Id.* annex III.

196. *Id.* art. 6(1).

197. *Id.* art. 6(3).

198. *Id.*

199. *Id.*

200. The documentation must include the serial numbers of the last motor vehicle produced in conformity with the old EEC type-approval certificate and, where applicable, the serial numbers of the first motor vehicle produced in conformity with the new EEC type-approval certificate. *Id.* art. 6(4).

one month.<sup>201</sup> Other member states need only be notified of minor changes on a periodic basis.<sup>202</sup>

Article 7 bars member states from refusing to register new motor vehicles accompanied by a certificate of conformity and from prohibiting the sale, entry into service, or use of any such vehicles if the refusal is based on the vehicle's construction or functioning.<sup>203</sup> This bar, however, does not prevent a member state from taking action against a motor vehicle where there are deviations between the motor vehicle and the approved prototype and these deviations have not been authorized by the issuance of an amended or new EEC type-approval certificate.<sup>204</sup>

If the member state granting EEC type-approval determines for itself or is informed by another member state that a number of vehicles accompanied by a certificate of conformity do not comply with the approval type, article 8 empowers the member state to take measures it deems necessary, including withdrawal of EEC type-approval, to ensure conformity between production models and the approved prototype.<sup>205</sup> The member state responsible for the EEC type-approval then advises other member states of the measures taken.<sup>206</sup> Notification of the withdrawal of EEC type-approval and the reasons for this measure must be given within one month. If a dispute arises among member states about conformance, the member states are encouraged to settle the dispute among themselves. The Commission acts as a mediator if settlement proves difficult.<sup>207</sup>

Article 9 permits a member state to refuse to register or to prohibit the sale, entry into service, or use of motor vehicles in that state for a period not exceeding six months if the motor vehicles are considered a hazard to road safety, even though they possess a certificate of conformity.<sup>208</sup> Notification of this step and the reasons supporting the decision must be given to the Commission and the other member states.<sup>209</sup>

Transitional measures are discussed in chapter III. Article 10

201. *Id.*

202. *Id.* art. 6(2).

203. *Id.* art. 7(1).

204. Article 7(2) provides further that "[a] vehicle shall not be considered to deviate from the approved type where tolerances are permitted by separate Directives and those tolerances are respected." *Id.* art. 7(2).

205. *Id.* art. 8(1).

206. *Id.* art. 8(2).

207. *Id.* art. 8(3).

208. *Id.* art. 9.

209. *Id.*

governs the period beginning with the date when the Type-Approval Directive comes into force and ending when the last directive involving a common technical standard comes into force. During this period type-approval is to be based on harmonized requirements if the applicant requests it, and all type-approval certificates issued to the manufacturer or his representative must be accepted by other member states as proof that the requisite checks have been carried out.<sup>210</sup>

Chapter IV contains "general and final provisions." Article 11 addresses itself to changes in the three annexes or changes in any of the directives involving common technical standards which are required by technical progress. All such changes are governed by article 13.<sup>211</sup>

The "Committee on the Adaptation to Technical Progress of the Directives on the Removal of Technical Barriers to Trade in the Motor Vehicle Sector" (Adaptation Committee) is established by Article 12. The Adaptation Committee consists of a chairman, who is a representative of the Commission, and representatives from the member states.<sup>212</sup> The Adaptation Committee is free to adopt its own procedural rules.<sup>213</sup>

Article 13 outlines the procedure to be followed where technical progress necessitates adaptation of directives or annexes. Measures are referred to the Adaptation Committee either by the chairman "on his own initiative or at the request of the representative of a member state."<sup>214</sup> The Adaptation Committee delivers its opinion on a particular measure within time limits set by the chairman.<sup>215</sup> Opinions are "adopted by a majority of 12 votes."<sup>216</sup>

The Commission can adopt measures which are in accordance with an opinion of the Adaptation Committee.<sup>217</sup> If, however, there is no opinion or an adverse opinion, the Commission must propose the adoption of the measure to the Council.<sup>218</sup> Inaction by the Council for a period of three months after the proposed measure is submitted to the Council allows the Commission to adopt

---

210. *Id.* art. 10(1).

211. *Id.* arts. 11, 13.

212. *Id.* art. 12(1).

213. *Id.* art. 12(2).

214. *Id.* art. 13(1).

215. *Id.* art. 13(2).

216. *Id.* The chairman does not vote. The votes of the member states are weighed according to art. 148(2) of the Treaty of Rome.

217. *Id.* art. 13(3)(a).

218. *Id.* art. 13(3)(b).

the measure.<sup>219</sup>

In cases involving refusal or withdrawal of EEC type-approval, refusal of registration, or prohibition of sale or use, article 14 provides that the member state taking such action must state in detail the reasons for its action.<sup>220</sup> The party affected by such action must be notified of the remedies available to him and the time limit within which the remedy must be exercised.<sup>221</sup>

Article 15 gives the member states eighteen months to implement the Type-Approval Directive by incorporating its provisions into their national law. The member states must inform the Commission when implementation has occurred and must supply the Commission with the text of the national law.<sup>222</sup>

Under the StVZO, in cases where a motor vehicle does not belong to an approved type, a manufacturer or a party authorized by him can secure an operating permit after an individual vehicle test has been conducted.<sup>223</sup> A motor vehicle letter must accompany the application for such an operating permit. An officially recognized expert must certify, either in the letter itself or in an accompanying report, that the letter accurately describes the characteristics of the motor vehicle and that the motor vehicle complies with all applicable regulations.<sup>224</sup> If the grant of the operating permit is conditioned on an exception, the exception and the officials authorizing it must be identified.

Section 22 of the StVZO permits the manufacturer of a part to conduct a test in order to secure an operating permit for that part. In order to qualify, the part must consist of a technical unit and must be capable of being tested separately from the motor vehicle.<sup>225</sup> Operating permits for parts can be limited in terms of the type of motor vehicle on which they can be installed or the method of installation. In granting an operating permit for a motor vehicle part, the type-test procedure is used for parts which are mass produced, and the individual test is used in all other cases.<sup>226</sup>

Throughout their useful lives, motor vehicles are also subject to periodic testing in accordance with section 29. All motor vehi-

---

219. *Id.* art. 13(3)(c).

220. *Id.* art. 14.

221. *Id.*

222. *Id.* art. 15.

223. StVZO, *supra* note 34, § 21.

224. *Id.*

225. *Id.* § 22(1).

226. *Id.* § 22(2).

cles and trailers, subject to certain exceptions,<sup>227</sup> must be tested at regular intervals in accordance with annex VIII to the StVZO, entitled "Inspection of Motor Vehicles."<sup>228</sup> Annex VIII is divided into eight parts.<sup>229</sup> Part 1 describes the types of inspection and their purposes. Motor vehicles and trailers are subject to three tests: a primary test,<sup>230</sup> an intermediate test,<sup>231</sup> and a special brake test.<sup>232</sup>

The purpose for each test is slightly different. The primary test determines whether the motor vehicle complies with the StVZO.<sup>233</sup> In the Primary Test Guidelines the Minister of Transportation directs that attention be given to nine points when conducting the primary test.<sup>234</sup> Point eight involves the "noise and air pollution characteristics" of the motor vehicle. The intermediate test checks those parts that are necessary to safely operate the motor vehicle and measures the noise characteristics of the vehicle.<sup>235</sup> In the Intermediate Test Guidelines the Minister of Transportation enumerates eight points to which attention should be given when conducting an intermediate test.<sup>236</sup> Point eight deals with the "noise and air pollution characteristics" of the motor vehicle.<sup>237</sup> In elaborating on the meaning of point eight, the Minister of Transportation indicates that "motor vehicles should not rumble, knock, or bang."<sup>238</sup> He directs that special attention be given to all muffler system components. As its name implies the purpose of the brakes test is to monitor the condition of the brakes.

A testing schedule is found in part 2 of annex VIII. It sets out the frequency of inspection for various vehicles according to the type of test to be performed on the vehicle.<sup>239</sup>

Part 3 outlines the testing procedure. Either officially recog-

---

227. For example, military and border patrol motor vehicles are exempt categories under § 29 of the StVZO. *Id.* § 29(1).

228. *Id.* The German term for annex is Anlage. Annex VIII is an annex to § 29 of StVZO.

229. Since pt. 8 of annex VIII is restricted to motor vehicles operated by the German Federal Railway and the German Federal Post Office, there will be no discussion of it.

230. Hauptuntersuchung.

231. Zwischenuntersuchung.

232. Bremsensonderuntersuchung.

233. StVZO, *supra* note 34, § 29 annex VIII, § 1.1.

234. Primary Test Guidelines, *supra* note 35.

235. StVZO, *supra* note 34, § 29 annex VIII, § 1.2.

236. Intermediate Test Guidelines, *supra* note 36.

237. *Id.*

238. *Id.*

239. StVZO, *supra* note 34, § 29 annex VIII, § 2.1.



nized experts<sup>240</sup> or inspectors<sup>241</sup> conduct primary tests.<sup>242</sup> The owner of a motor vehicle must apply for a primary test no later than the beginning of the month in which his approval certificate<sup>243</sup> expires.<sup>244</sup> The expert or inspector determines where and when the primary test will be conducted. If the expert or inspector discovers a defect while conducting the primary test and refuses to issue an approval certificate, the owner must correct the defect and present his motor vehicle for a follow-up test<sup>245</sup> no later than six weeks after the refusal.<sup>246</sup> A new primary test must be conducted if more than two months elapse between the date of refusal and the date of presentment.<sup>247</sup> If the defect renders the motor vehicle unsafe to operate, the expert or inspector is required to remove the approval certificate and immediately notify the appropriate authorities.<sup>248</sup>

Manufacturers or officially recognized service stations conduct intermediate tests.<sup>249</sup> The manufacturer of the braking system, any brake manufacturer, or an officially recognized service station conduct special brake tests.<sup>250</sup>

Three special forms of inspection are recognized by section 4 of annex VIII: in-house inspections, *i.e.*, owner inspections at the owner's facilities, monitoring organization inspections, and service station inspections. The owner of a motor vehicle can conduct an in-house primary test, provided it has been authorized and is conducted before the end of the month in which the approval certificate expires.<sup>251</sup> In-house intermediate and special brake tests can also be authorized.<sup>252</sup>

A monitoring organization can conduct primary tests, provided the monitoring organization is officially recognized and has entered into a contractual arrangement with a manufacturer to conduct primary tests on a regular basis.<sup>253</sup> If a manufacturer chooses to have a monitoring organization conduct primary tests,

240. The German term for expert is Sachverständiger.

241. The German term for inspector is Prüfer.

242. StVZO, *supra* note 34, § 29 annex VIII, § 3.1.

243. Prüfplakette.

244. StVZO, *supra* note 34, § 29 annex VIII, § 3.1.

245. Nachprüfung.

246. StVZO, *supra* note 34, § 29 annex VIII, § 3.3.

247. *Id.*

248. *Id.*

249. *Id.* § 29 annex VIII, § 3.4.

250. *Id.* § 29 annex VIII, § 3.5.

251. *Id.* § 29 annex VIII, § 4.1.1.

252. *Id.* § 29 annex VIII, § 4.1.3.

253. *Id.* § 29 annex VIII, § 4.2.1.

the tests are conducted on either a six-month or annual basis, depending on whether the testing schedule calls for primary tests at twelve- or twenty-four-month intervals.<sup>254</sup> Monitoring organizations receive official recognition to conduct primary tests for five-year periods.<sup>255</sup> If a monitoring organization discovers a minor defect and the defect is of the type which the owner would normally correct, an approval certificate can be issued.<sup>256</sup> Exceptions are possible, but only the highest state officials or their designees can grant them.<sup>257</sup>

Service stations can conduct primary tests, provided the service station is officially authorized and the motor vehicle to be inspected is not subject to intermediate or special brake tests.<sup>258</sup> If an owner chooses to have a service station conduct the primary test, the test is conducted on a six-month or annual basis, depending on whether the testing schedule calls for primary tests at twelve- or twenty-four-month intervals.<sup>259</sup>

When the primary inspection is conducted, the expert or inspector completes an inspection report.<sup>260</sup> If a follow-up test is ordered, this report must indicate what defects were discovered, and the results of the follow-up test.<sup>261</sup>

Part 5 provides for the preparation and retention of inspection records in a form approved by the FOMV for all motor vehicles subject to the intermediate and special brake test.<sup>262</sup> When an intermediate or special brake test is conducted, the date of the inspection, any defects, and the action taken are noted.<sup>263</sup> An authorized person or the expert or inspector who conducts the primary test can demand to see the inspection records in order to ascertain whether the intermediate and special brake tests were conducted according to schedule.<sup>264</sup> If the inspections were not conducted or were conducted tardily, the appropriate authorities must be notified.<sup>265</sup>

---

254. *Id.*

255. *Id.* § 29 annex VIII, § 4.2.3.

256. *Id.*

257. *Id.* § 29 annex VIII, § 4.2.3.

258. *Id.* § 29 annex VIII, § 4.3.1.

259. *Id.*

260. *Id.* § 29 annex VIII, § 5.4.

261. *Id.*

262. *Id.* § 29 annex VIII, § 5.1.

263. *Id.* § 29 annex VIII, § 5.2.

264. *Id.* § 29 annex VIII, § 5.3. The Primary Test Guidelines *require* the expert or inspector to ascertain whether the intermediate and special brake tests have been performed according to schedule. Primary Test Guidelines, *supra* note 35.

265. StVZO, *supra* note 34, § 29 annex VIII, § 5.3.

Authorizations to conduct in-house and service station inspections are conferred by the highest state officials for five-year periods.<sup>266</sup> The authorization is nontransferable,<sup>267</sup> may be made subject to conditions or limitations to insure that the tests are properly conducted,<sup>268</sup> and may be withdrawn<sup>269</sup> or cancelled.<sup>270</sup> Annex VIII requires state officials to satisfy themselves, either directly or through experts, that (1) the requirements for the authorization are being complied with by the recipient of the authorization, (2) the inspections are properly conducted, and (3) the authorization is being properly used.<sup>271</sup> The recipient must assist these state officials and bear any costs associated with these actions.<sup>272</sup>

On December 29, 1976, the Council of the European Communities adopted the Roadworthiness Directive. The Roadworthiness Directive consists of a preamble, eight articles, and two annexes. Article 1 provides that "motor vehicles registered [in each member state] and their trailers and semi-trailers shall undergo periodic roadworthiness tests in accordance with this Directive and its Annexes."<sup>273</sup> Annexes I and II list the categories of motor vehicles to be tested, the frequency of testing, and the items to be tested. The categories of motor vehicles subject to the Roadworthiness Directive are vehicles with more than eight seats that are used to carry passengers, vehicles used to carry goods that have maximum permissible weight exceeding 3500 kilograms/7700 pounds, trailers and semi-trailers that have maximum permissible weight exceeding 3500 kilograms/7700 pounds, taxis, and ambulances.<sup>274</sup> The testing must occur "[o]ne year after the date on which the vehicle was first used, and thereafter annually."<sup>275</sup> Annex II lists the items subject to inspection.<sup>276</sup> Item 8.1 requires testing of the noise characteristics of the vehicle.<sup>277</sup>

---

266. *Id.* § 29 annex VIII, § 4.1.2 (in-house inspections), .3.3 (service station inspections).

267. *Id.* § 29 annex VIII, § 6.3.

268. Annex VIII offers no illustrations of the kinds of conditions which might be necessary to insure that primary, intermediate, or special brake tests are properly conducted. *Id.*

269. *Id.* § 29 annex VIII, § 6.4.

270. *Id.* § 29 annex VIII, § 6.5.

271. *Id.* § 29 annex VIII, § 6.7.

272. *Id.*

273. Roadworthiness Directive, *supra* note 65, art. 1.

274. *See id.* annex I.

275. *Id.*

276. *Id.* annex II.

277. *Id.*

Certain categories of motor vehicles are or may be exempted by article 2 from the coverage of the Roadworthiness Directive. Member states have the right to exclude military and police motor vehicles.<sup>278</sup> After consultation with the Commission, member states may exclude "certain vehicles operated or used in exceptional conditions and vehicles which are never, or hardly ever, used on public highways, or which are temporarily withdrawn from circulation."<sup>279</sup>

Notwithstanding annexes I and II, article 3 permits member states to:

- bring forward the date for the first compulsory roadworthiness tests and, where appropriate, submit the vehicle for testing prior to registration,
- shorten the interval between two successive compulsory tests,
- make the testing of optional equipment compulsory,
- increase the number of items to be tested,
- extend the periodic test requirement to other categories of vehicles,
- prescribe special additional tests.<sup>280</sup>

Article 4 empowers member states or "bodies or establishments designated and directly supervised by [them]" to conduct the roadworthiness tests.<sup>281</sup> Under article 5, member states are free to take whatever measures they deem necessary to insure that vehicles pass roadworthiness tests complying with the requirements of the Roadworthiness Directive.<sup>282</sup> Each member state is required to notify other member states and the Commission of these measures<sup>283</sup> and to "recognize the proof issued in another Member State to the effect that a motor vehicle registered in that other State, together with its trailer or semi-trailer, have passed a roadworthiness test complying with at least the provisions of this Directive."<sup>284</sup>

Article 6 requires member states to adopt laws, regulations, or administrative provisions to implement the Roadworthiness Directive within one year.<sup>285</sup> Under article 7, however, member states may:

---

278. *Id.* art. 2.

279. *Id.*

280. *Id.* art. 3.

281. *Id.* art. 4.

282. *Id.* art. 5(1).

283. *Id.* art. 5(2).

284. *Id.* art. 5(3).

285. *Id.* art. 6.

- postpone the date of the first compulsory roadworthiness test,
- extend the interval between two successive compulsory roadworthiness tests,
- reduce the number of items to be tested,
- amend the categories of vehicles subject to compulsory roadworthiness tests<sup>286</sup>

until January 1, 1983.

Regulations with respect to vehicle construction and operation are found in part III of chapter B in the StVZO, consisting of thirty-four sections. Section 30 establishes standards for motor vehicle construction. Motor vehicles must be constructed and equipped so that “no one is injured or unreasonably endangered, hindered or disturbed by their normal operation.”<sup>287</sup>

The question of liability is analyzed in section 31. Operators, generally speaking, are responsible for their motor vehicles since “an individual who operates a motor vehicle . . . must be qualified.”<sup>288</sup> In some situations, however, the owner rather than the operator must assume either total or partial responsibility. The owner is liable if he orders or permits another to operate a motor vehicle when he knows or ought to know that the other individual is not qualified.<sup>289</sup> The owner is likewise liable if he knows or ought to know that the vehicle itself or the manner in which the vehicle is equipped or loaded is inconsistent with the applicable regulations or is not conducive to operational safety.<sup>290</sup>

Section 35e of the StVZO deals with doors. “Doors and locks must be constructed so as to minimize disturbing noise when the door is being closed.”<sup>291</sup> Since inconsistent technical standards for doors could impede the free flow of motor vehicles throughout the EEC, the Council adopted the Door Directive on July 27, 1970. The Door Directive consists of a preamble, five articles, and two annexes. Article 1 of the Door Directive defines “vehicle” and lists exceptions to that definition.<sup>292</sup> If the requirements with respect to doors found in the annexes are satisfied, article 2 prohibits a member state from refusing to grant EEC or national type-approval to a vehicle.<sup>293</sup> In responding to technical progress, arti-

---

286. *Id.* art. 7.

287. StVZO, *supra* note 34, § 30(1)(1).

288. *Id.* § 31(1).

289. *Id.* § 31(2).

290. *Id.*

291. *Id.* § 35e.

292. Door Directive, *supra* note 62, art. 1.

293. *Id.* art. 2.

cle 13 of the Type-Approval Directive establishes a procedure to follow in adapting technical standards.<sup>294</sup> Article 3 of the Door Directive confirms the applicability of that procedure to the requirements contained in the annex.<sup>295</sup> Article 4 of the Door Directive, which sets the time limit for implementation and imposes certain reporting requirements, is similar to article 15 of the Type-Approval Directive.<sup>296</sup> Section 1.3 of annex I to the Door Directive provides that “[d]oors and door latches must be designed in such a way that any irritating noise on closing may be avoided.”<sup>297</sup>

“Best available technology”<sup>298</sup> is a concept frequently encountered in German as well as American traffic noise law. An explanation of its role in the StVZO is found in section 49. Section 49 states that “[m]otor vehicles and their trailers must be constructed so that their noise level does not exceed by an unreasonable degree the noise level dictated by the best available technology.”<sup>299</sup>

If there is reason to believe that the noise emission level of a motor vehicle exceeds the level dictated by the best available technology, an authorized individual can direct the operator to have his motor vehicle tested at the nearest inspection station,<sup>300</sup> provided the inspection station is in the direction the operator is traveling and provided the trip to the inspection station does not involve a detour of more than 6 kilometers/4 miles.<sup>301</sup> A report of the results of the test are supplied to the operator. If the results

294. See notes 211-19 and accompanying text *supra*.

295. Door Directive, *supra* note 62, art. 3.

296. See note 222 and accompanying text *supra*.

297. Door Directive, *supra* note 62, annex I, § 1.3.

298. The German phrase for “best available technology” is “jeweiliger Stand der Technik.”

299. StVZO, *supra* note 34, § 49(1). A violation of the StVZO is possible even if the noise level of a motor vehicle does not exceed the noise level dictated by best available technology. See Judgment of Aug. 13, 1958, Oberlandesgericht Celle, W. Ger., 4 NOISE HANDBOOK, *supra* note 2, ¶ 60,107 (1 Ss 173/58), where the court held that the determination to be made is not whether the standard of best available technology has been satisfied but whether “the noise was avoidable under the circumstances, particularly location and time.”

For further discussion of § 49 of the StVZO in German decisions, see Judgment of Mar. 21, 1961, Oberlandesgericht Köln, W. Ger., 4 NOISE HANDBOOK, *supra* note 2, ¶ 60,111 (Ss 525/60); Judgment of May 5, 1961, Oberlandesgericht Stuttgart, W. Ger., 4 NOISE HANDBOOK, *supra* note 2, ¶ 60,112 (1 Sa 781/60).

300. StVZO, *supra* note 34, § 49(2).

301. *Id.* The detour proviso in § 49 of the StVZO is important and significantly curtails the effectiveness of § 49. The likelihood that an inspection station will be 6 km./3.7 mi. from the point where a motor vehicle is stopped *and* in the direction in which the motor vehicle is traveling is not great.

show a noise emission level in excess of the noise emission level dictated by the best available technology, the costs of the test must be borne by the operator.<sup>302</sup>

Section 55 of the StVZO requires that motor vehicles be equipped with an audible warning device.<sup>303</sup> The tone of an audible warning device must make endangered individuals aware of an approaching motor vehicle without terrifying or needlessly disturbing them.<sup>304</sup> One-tone or harmonious-tone horns are permissible, but they must be free of auxiliary sounds.<sup>305</sup> Section 55 prohibits horns whose volume exceeds 104 DIN-phon<sup>306</sup> measured 6 meters/19.7 feet from the horn and 0.5-1.5 meters/1.6-4.9 feet above the highway.<sup>307</sup> The testing of vehicle compliance with the foregoing noise emission level is carried out in an open area with a smooth surface. Obstacles that could affect the measurement must be at least twice as far from the horn as the measuring device.<sup>308</sup> Audible warning devices that emit a series of increasing tones can only be installed on motor vehicles that carry flashing lights.<sup>309</sup> All other warning signals are prohibited.<sup>310</sup>

Since inconsistent technical standards for warning devices could impede the free flow of motor vehicles throughout the EEC, the Council adopted the Warning Device Directive on July 27, 1970. The Warning Device Directive consists of a preamble, eleven articles, and two annexes.

Article 1 of the Warning Device Directive provides that "any type of audible warning device which satisfies the construction and testing requirements laid down in . . . Annex I" shall be approved for use by a member state.<sup>311</sup> Measures can be taken either by the member state itself or in cooperation with another member state "to verify . . . that production models conform to the approved prototype. Such verification is limited to spot checks."<sup>312</sup>

In accordance with article 2, either the manufacturer or his

302. *Id.*

303. *Id.* § 55(1).

304. *Id.*

305. *Id.* § 55(2).

306. A level of 104 DIN-phon is equivalent to 104 dB(A). See ENVIRONMENTAL REPORT, *supra* note 10, at 193 n.1.

307. StVZO, *supra* note 34, § 55(2).

308. *Id.*

309. *Id.* § 55(3).

310. *Id.* § 55(4).

311. Warning Device Directive, *supra* note 63, art. 1.

312. *Id.* art. 1(2).

authorized representative is issued an EEC type-approval mark.<sup>313</sup> Marks should be chosen that make it possible to readily distinguish between approved and nonapproved warning devices.<sup>314</sup>

Article 3 bars member states from prohibiting the marketing of warning devices because of their construction or method of operation if the devices bear an EEC type-approval mark.<sup>315</sup> Member states are also barred by article 7 from refusing to grant EEC or national type-approval to a motor vehicle because of its warning device if the device bears an EEC type-approval mark and is installed in accordance with the requirements found in the annex.<sup>316</sup>

Nevertheless, member states may take measures against warning devices bearing the EEC type-approval mark if the design of the warning signal does not conform to the approved prototype.<sup>317</sup> A member state taking such action must inform the other member states and the Commission of the action taken and the reasons for taking it.<sup>318</sup>

Article 4 requires a member state to whom application has been made for type-approval to send the other member states a copy of the type-approval certificate for each type of warning device within one month of the time the approval is granted or denied.<sup>319</sup>

Article 9 expresses the expectation that the requirements in the Warning Device Directive will be adjusted periodically. Such adjustments are subject to the procedure outlined in article 13 of the Type-Approval Directive.<sup>320</sup>

Article 5, which deals with the problem of nonconforming warning devices; article 6, which outlines the notification requirements when a member state refuses or withdraws type-approval of a warning device or prohibits its manufacture or use; article 8, which defines "vehicle" and lists the exceptions to that definition; and article 10, which sets the time limit for implementation and imposes certain reporting requirements, are, respectively,

---

313. *Id.* art. 2. Section 1.4 of annex I to the Warning Device Directive contains a model type-approval mark.

314. *Id.* annex I, § 1.4.

315. *Id.* art. 3(1).

316. *Id.* art. 7.

317. *Id.* art. 3(2).

318. *Id.*

319. *Id.* art. 4.

320. *Id.* art. 9. For a discussion of art. 13 of the Type-Approval Directive, see notes 214-19 and accompanying text *supra*.



similar to articles 8, 14, 1, and 15 of the Type-Approval Directive.<sup>321</sup>

Annex I to the Warning Device Directive is divided into two parts. The first part is entitled "EEC Type-Approval of an Audible Warning Device." According to the first part of annex I, an audible warning device must "emit a continuous sound."<sup>322</sup> Type-approval tests are performed "on two samples of each type submitted by the manufacturer for approval."<sup>323</sup> The samples are tested in either a "sufficiently silent and open area"<sup>324</sup> or an "anechoic chamber."<sup>325</sup> In conducting the tests, the microphone taking the measurement is positioned at a height of 1.2 meters/3.9 feet above ground level and 2 meters/6.6 feet from the front surface of the warning device.<sup>326</sup> Measurements are taken in dB(A) by a sound level meter that conforms "to the type described in Publications 179, 1st ed. (1965), of the International Electrotechnical Commission."<sup>327</sup> Under these and other conditions specifically set forth in the annex, "the subjective sound pressure level must be not more than 118 dB(A) and not less than 105 dB(A)."<sup>328</sup>

Endurance and acoustic tests are also conducted. In the endurance test, the warning device is operated 50,000 times, with the period of operation lasting one second followed by a four-second break.<sup>329</sup> In the acoustic test, "[t]he spectrum of the sound emitted by the device, . . . must show a sound pressure higher than that of any frequency component above 3550 Hz in the 1800 to 3550 Hz frequency band, and in no case less than 105 dB(A)."<sup>330</sup> The acoustic test is performed in an anechoic chamber.<sup>331</sup>

The second part of annex I is entitled "Characteristics of the Audible Warning Device When Fitted to the Vehicle." If the device has been installed, "[t]he sound pressure level . . . shall be measured at a point 7 [meters/23 feet] in front of the vehicle at

321. Type-Approval Directive, *supra* note 64.

322. Warning Device Directive, *supra* note 63, annex I, § 1.1.

323. *Id.* annex I, § 3.1.

324. An area is sufficiently silent and open when the "ambient noise and wind noise is at least 10 dB(A) below the noise being measured." *Id.* annex I, § 1.2.1.1.

325. *Id.*

326. *Id.*

327. *Id.* annex I, § 1.2.1.2.

328. *Id.* annex I, § 1.2.1.6.

329. *Id.* annex I, § 1.2.2.1.

330. *Id.* annex I, § 1.2.3.1.

331. *Id.* annex I, § 1.2.3.7.

a site which is open and as level as possible.”<sup>332</sup> Measurements are taken in dB(A). “The maximum sound pressure level [is] determined at a height of between 0.5 to 1.5 [meters/1.6-4.9 feet] above ground level.”<sup>333</sup> “The maximum must be not less than 93 dB(A).”<sup>334</sup>

Unlike chapter B, chapter C of the StVZO, consisting of five sections, is not divided into parts. Section 68 addresses the question of general and special jurisdiction. Special jurisdiction exists in cases involving the military, the German Federal Railway, the German Federal Post Office, the German Federal Border Patrol, and the police.<sup>335</sup> General jurisdiction exists in all other cases.

General jurisdiction is exercised in some cases by higher administrative officials<sup>336</sup> and in other cases by lower administrative officials<sup>337</sup> or officials assigned the duties of lower administrative officials by state law.<sup>338</sup> General jurisdiction is territorial in nature and, therefore, its exercise is restricted to the Federal Republic of Germany.<sup>339</sup> In cases involving natural persons, the place where the complainant or the affected party resides is critical in determining which official has jurisdiction.<sup>340</sup> The “seat,” the place where a facility is located, or the place of doing business is critical in determining which official has jurisdiction over a legal person.<sup>341</sup> If necessity requires, any similarly situated official can act in place of the official who has territorial jurisdiction.<sup>342</sup>

If an individual, intentionally or negligently, violates the provisions of the StVZO, section 69 states that such a violation constitutes an administrative offense within the meaning of section 24 of the StVG.<sup>343</sup> Administrative offenses include, *inter alia*, violations of section 35e, 49, and 55.<sup>344</sup>

Exceptions to the StVZO are possible. Section 70 indicates who can grant exceptions and what types can be granted.<sup>345</sup> The

332. *Id.* annex I, § 2.1.1.

333. *Id.* annex I, § 2.1.3.

334. *Id.* annex I, § 2.1.4.

335. StVZO, *supra* note 34, § 68(3).

336. Höhere Verwaltungsbehörde.

337. Untere Verwaltungsbehörde.

338. StVZO, *supra* note 34, § 68(1).

339. *Id.* § 68(2).

340. *Id.*

341. *Id.*

342. *Id.*

343. *Id.* § 69a(1), (2), (3), (5).

344. *Id.* § 69a(3), (7b), (17), (22).

345. *Id.* § 70(1), (2).

grant of an exception should state its territorial limits.<sup>346</sup> The grant of an exception can be coupled with the payment of a fee as provided for in section 71.<sup>347</sup>

#### 4. *Muffler Replacement Regulations*

The Muffler Replacement Regulations were issued by the Minister of Transportation on July 10, 1956. Mufflers are one of the motor vehicle parts covered by section 19 of the StVZO.<sup>348</sup> If a muffler is replaced during the useful life of the motor vehicle, the replacement muffler should be a model approved in the operating permit granted pursuant to section 19.<sup>349</sup> A nonapproved model can be used, provided that model does not permit noise emissions at a level in excess of the actual noise level<sup>350</sup> measured during the type test.<sup>351</sup>

#### 5. *Other noise emission guidelines, directives, and amendments*

The German Noise Emission Guidelines were initially issued on July 14, 1958. On September 13, 1966, the guidelines, which had been amended on numerous occasions between 1958 and 1966, were completely revised.<sup>352</sup>

The Close-Range Stationary Measurement Guidelines were issued on December 16, 1976. Both the Primary Test Guidelines and the Intermediate Test Guidelines require the expert or inspector conducting a primary or intermediate test to satisfy himself that the noise emitted by the motor vehicle during a stationary test is within the limits set by section 29 and annex VIII of the StVZO.<sup>353</sup> If doubt exists as to compliance, the expert or inspector may resort to the measurement procedures found in the German Noise Emission Guidelines or the Close-Range Sta-

346. *Id.* § 70(3).

347. *Id.* § 71. See Judgment of May 5, 1961, Oberlandesgericht Stuttgart, W. Ger., 4 NOISE HANDBOOK, *supra* note 2, ¶ 60,112 (1 Sa 781/60).

348. See notes 156-66 and accompanying text *supra*.

349. Muffler Replacement Regulations, *supra* note 37.

350. A distinction is drawn between "actual noise level" and "highest permissible noise level." The former usually is lower than the latter. Consequently, the replacement muffler is required to meet the "actual noise level" standard. *Id.*

351. *Id.*

352. German Noise Emission Guidelines, *supra* note 38. Over the years, the noise emission levels for motor vehicles permitted by the German Noise Emission Guidelines have been reduced on "numerous occasions." ENVIRONMENTAL PLANNING, *supra* note 41, at 251.

353. Close-Range Stationary Measurement Guidelines, *supra* note 39.

tionary Measurement Guidelines.<sup>354</sup>

The Close-Range Stationary Measurement Guidelines are divided into eight parts. According to part 1, close-range stationary tests can be conducted on motor vehicles of all types, except those that vent their exhaust in an upward direction.<sup>355</sup> Test results obtained by such measurements, however, can only be used for comparative purposes.<sup>356</sup> No direct relationship exists between the noise level thus obtained and total vehicle noise, nor can any conclusions about total vehicle noise be drawn from the noise level thus obtained.<sup>357</sup>

Parts 4 and 5 describe measurement conditions. The microphone is located approximately 50 centimeters/19.6 inches<sup>358</sup> from the muffler on a level with the muffler but at least 20 centimeters/7.2 inches above the ground and at an angle of approximately forty-five degrees<sup>359</sup> to the direction in which the exhaust is vented.<sup>360</sup> The ambient noise level must be at least 10 dB(A) lower than the measured noise level.<sup>361</sup> A wind shield can be placed on the microphone.<sup>362</sup>

Three measurements are called for by part 6, the average of which becomes the test result.<sup>363</sup> A tolerance factor of 5 dB(A) is permitted to adjust for sound level measurement inaccuracies.<sup>364</sup>

Section 8 permits close-range stationary tests for motor vehicles placed in operation before the Close-Range Stationary Measurement Guidelines were issued. Before the results of such tests can be compared with the characteristics for the motor vehicle described in the motor vehicle letter, however, 17 dB(A), plus a 5 dB(A) tolerance factor, or 22 dB(A) must be added to the test result for automobiles and trucks, and 21 dB(A), plus a 5 dB(A) tolerance factor, or 26 dB(A) must be added to the test result for motorcycles.<sup>365</sup>

The revised German Noise Emission Guidelines have been

---

354. *Id.* In his introduction to the Close-Range Stationary Measurement Guidelines, the Minister of Transportation offers them as an "easier and timesaving" alternative to the German Noise Emission Guidelines. *Id.*

355. *Id.* § 1.

356. *Id.*

357. *Id.*

358. A tolerance factor of  $\pm 2.5$  cm./1 in. is permitted. *Id.* § 4.

359. A tolerance factor of  $\pm 10$  degrees is permitted. *Id.*

360. *Id.*

361. *Id.* § 5.

362. *Id.*

363. *Id.* § 6.

364. *Id.*

365. *Id.* § 8.

largely superseded by the EEC Noise Emission Directive adopted by the Council on February 6, 1970, and incorporated into German law on October 26, 1971.<sup>366</sup> The EEC Noise Emission Directive, however, contains no counterpart to the Close-Range Stationary Measurement Guidelines.

The EEC Noise Emission Directive consists of a preamble, five articles, and an annex. In the preamble, the Council notes that national laws with respect to permissible sound levels and exhaust systems differ from member state to member state. Such a situation was deemed to be inconsistent with the need to harmonize technical standards and the need to establish an EEC type-approval procedure.<sup>367</sup> Consequently, "it [was] . . . necessary that all Member States adopt the same requirements [relating to permissible noise levels and exhaust systems] either in addition to or in place of their existing rules . . . ."<sup>368</sup>

Article 1 of the EEC Noise Emission Directive, which defines "vehicle" and lists exceptions to that definition, is identical to article 1 of the Type-Approval Directive.<sup>369</sup> If the requirements with respect to permissible noise levels and exhaust systems found in the annex are satisfied, article 2 prohibits a member state from refusing to grant either EEC or national type-approval to a motor vehicle.<sup>370</sup>

The Type-Approval Directive establishes a procedure to be followed where technical progress necessitates adaptation of a technical standard.<sup>371</sup> Its application to the EEC Noise Emission Directive is discussed in article 3. Although most of the requirements contained in the annex to the EEC Noise Emission Directive are subject to the procedure,<sup>372</sup> sections I.1 (permissible sound level limits) and I.4.1.4 (interpretation of the results of the moving vehicle test) are not.<sup>373</sup>

The annex to the EEC Noise Emission Directive is divided into two parts. Part I is entitled "Permissible Sound Levels"<sup>374</sup>

---

366. The German Noise Emission Guidelines and the EEC Noise Emission Directive are similar but not identical. For example, motorcycles are covered by the German Noise Emission Guidelines but are not covered by the EEC Noise Emission Directive. There are also minor differences in the testing procedure.

367. EEC Noise Emission Directive, *supra* note 59, preamble.

368. *Id.*

369. See note 185 and accompanying text *supra*.

370. EEC Noise Emission Directive, *supra* note 59, art. 2.

371. See notes 211-19 and accompanying text *supra*.

372. EEC Noise Emission Directive, *supra* note 59, art. 3.

373. *Id.* art. 3, annex § I.1, .4.1.4.

374. In the German version of the EEC Noise Emission Directive, pt. I is entitled "Zulässiger Geräuschpegel."

and summarizes the permissible sound levels in dB(A) for various vehicles defined by article 1.<sup>375</sup> The sound level is measured by a sound-level meter. The annex specifies that the sound-level meter must be of the type described in Publication 179 of the International Electrotechnical Commission.<sup>376</sup>

Measurement conditions are spelled out in considerable detail. Ideally, the measurements should take place in an open area with a 50 meter/164 foot radius.<sup>377</sup> The actual testing area must have a 20 meter/65.6 foot radius.<sup>378</sup> This area must be flat and must not be covered with snow, grass, loose soil, or ashes.<sup>379</sup> The road surface over which the motor vehicle travels during the moving test must be concrete, asphalt, or a similar material so as to minimize excessive tire noise.<sup>380</sup> Measurements should be carried out in good weather when there is little wind.<sup>381</sup> As a rule of thumb, the ambient noise level should be at least 10 dB(A) below the sound level to be measured.<sup>382</sup> No one other than the individual taking the reading may remain near the motor vehicle or the microphone.<sup>383</sup>

The annex contemplates two types of tests—moving or stationary—and outlines the procedure to be followed in each test.<sup>384</sup> A maximum of two measurements are made, in the moving test, on each side of the motor vehicle with the microphone located 1.2 meters/3.9 feet above ground level and at a distance of 7.5

---

375. EEC Noise Emission Directive, *supra* note 59, annex § I.1.

376. *Id.* annex § I.2.

377. *Id.*

378. *Id.*

379. *Id.* annex § I.3. Compare *id.* with (United States) New Truck Regulations, Section II, notes 303-04 and accompanying text *supra*.

380. EEC Noise Emission Directive, *supra* note 59, annex § I.3. Compare *id.* with (United States) New Truck Regulations, Section II, note 303 and accompanying text *supra*.

381. EEC Noise Emission Directive, *supra* note 59, annex § I.3. The New Truck Regulations in effect in the United States define a permissible level of wind. See Section II, note 306 and accompanying text *supra*.

382. EEC Noise Emission Directive, *supra* note 59, annex § I.3. Compare *id.* with (United States) New Truck Regulations, Section II, note 305 and accompanying text *supra*.

383. EEC Noise Emission Directive, *supra* note 59, annex § I.3.

384. The test site for the moving test is shown in Fig. A

Fig. A

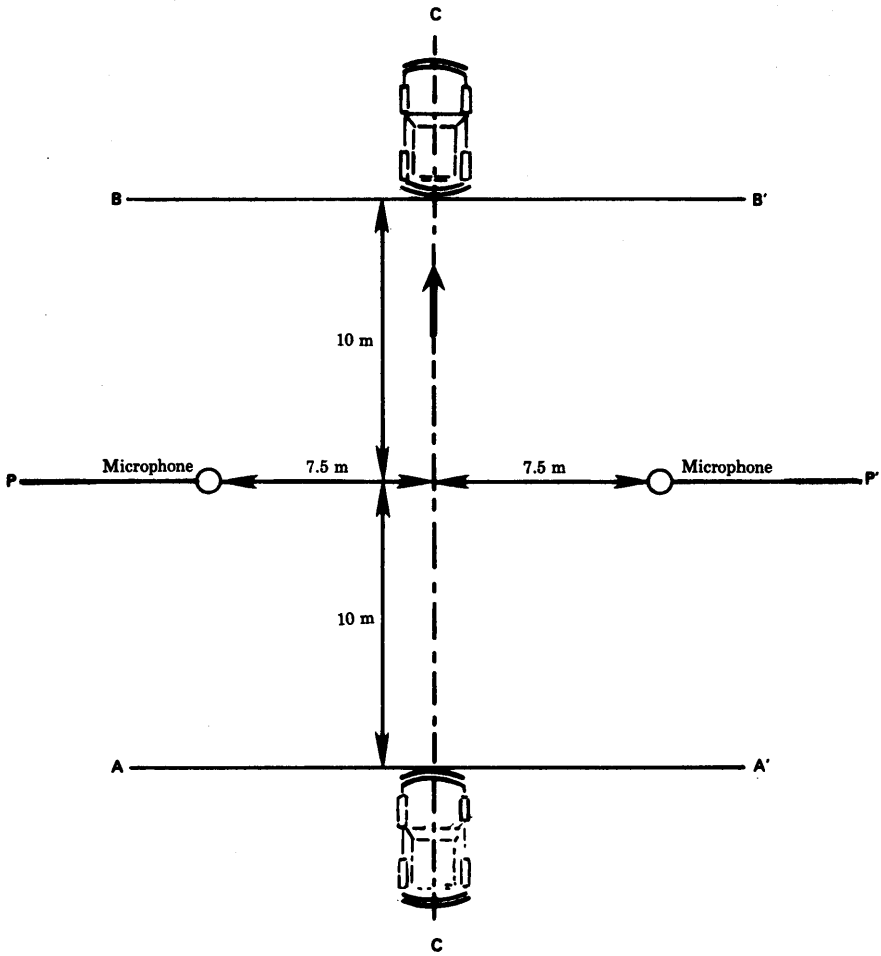

---

*Id.* annex § I.4.1. The test site for the stationary test is shown in Fig. B.

meters/24.6 feet from the path traveled by the vehicle.<sup>385</sup> As the motor vehicle approaches a point 10 meters/32.8 feet from the microphone at a steady speed, the throttle is fully opened as rapidly as possible and held fully open until the rear of the motor vehicle crosses a point 10 meters/32.8 feet past the microphones, where the throttle is then closed as rapidly as possible.<sup>386</sup>

Three types of moving tests can be conducted: a test for motor vehicles without a gearbox,<sup>387</sup> a test for motor vehicles with manual transmission,<sup>388</sup> and a test for motor vehicles with automatic transmission.<sup>389</sup> If the motor vehicle has no gearbox, the vehicle approaches the testing area at a steady speed that corresponds to the lowest of (1) an engine speed equal to three-fourths of the engine speed at which the engine develops its maximum power, (2) an engine speed equal to three-fourths of the maximum

Fig. B

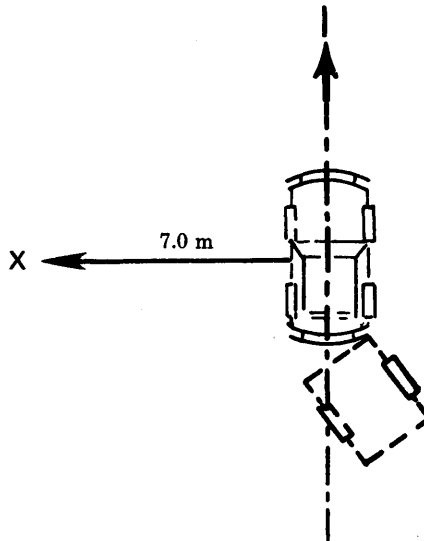

*Id.* annex § I.4.2.

385. *Id.* annex I.4.1. Respecting the two measurements, compare *id.* with (United States) New Truck Regulations, Section II, notes 314-17 and accompanying text *supra*. Respecting the microphone placement, compare EEC Noise Emission Directive, *supra* note 59, annex I.4.1. with (United States) New Truck Regulations, Section II, note 307 and accompanying text *supra*.

386. EEC Noise Emission Directive, *supra* note 59, annex § I.4.1. Compare *id.* with (United States) New Truck Regulations, Section II, notes 310-12 and accompanying text *supra*.

387. EEC Noise Emission Directive, *supra* note 59, annex § I.4.1.1.

388. *Id.* annex § I.4.1.2.

389. *Id.* annex § I.4.1.3.



engine speed permitted, or (3) 50 kmph/31 mph.<sup>390</sup>

Manual transmission vehicles must be in second gear if the motor vehicle has a two-, three-, or four-speed gearbox,<sup>391</sup> in third gear if the motor vehicle has more than a four-speed gearbox,<sup>392</sup> or in the ratio allowing the highest vehicle speed if the transmission has a double gear ratio.<sup>393</sup> The motor vehicle then approaches the testing spot at a steady speed that corresponds to the lowest of (1) an engine speed equal to three-fourths of the engine speed at which the engine develops its maximum power, (2) engine speed equal to three-fourths of the maximum engine speed permitted, or (3) 50 kmph/31 mph.<sup>394</sup> If the motor vehicle is equipped with automatic transmission, the motor vehicle approaches the testing ground at a steady speed equal to the lower of 50 kmph/31 mph or three-fourths of the maximum speed.<sup>395</sup>

Part I recognizes the possibility of inaccuracies. Consequently, 1 dB(A) is subtracted from each measurement.<sup>396</sup> The measurements are considered valid if the difference between two consecutive measurements on the same side does not exceed 2 dB(A).<sup>397</sup> The highest measurement is the test result.<sup>398</sup> Should this result exceed by 1 dB(A) the maximum permissible sound level, two further measurements must be made.<sup>399</sup> Three of the four measurements thus obtained must fall within the prescribed limits.<sup>400</sup>

In the stationary test, two measurements<sup>401</sup> are taken by a microphone located 1.2 meters/3.9 feet above ground level and 7 meters/23 feet from the nearest surface of the motor vehicle.<sup>402</sup> Motor vehicles with governors<sup>403</sup> are tested differently than those without governors.<sup>404</sup> If the motor vehicle has a governor, the

---

390. *Id.* annex § I.4.1.1.

391. *Id.* annex § I.4.1.2.1.

392. *Id.* annex § I.4.1.2.2.

393. *Id.* annex § I.4.1.2.3.

394. *Id.*

395. *Id.* annex § I.4.1.3.

396. *Id.* annex § I.4.1.4.1.

397. *Id.* annex § I.4.1.4.2. Compare *id.* with (United States) New Truck Regulations, Section II, note 315 and accompanying text *supra*.

398. EEC Noise Emission Directive, *supra* note 59, annex § I.4.1.4.3.

399. *Id.*

400. *Id.*

401. *Id.* annex § I.4.2.2.

402. *Id.* annex § I.4.2.1.

403. A governor prevents the engine from exceeding the speed at which maximum power is developed.

404. EEC Noise Emission Directive, *supra* note 59, annex § I.4.2.3.

motor is run at maximum speed.<sup>405</sup> A motor vehicle without a speed governor is run at three-fourths of the revolutions per minute at which maximum power is developed. Before conducting the test, the engine is warmed to its normal running temperature.<sup>406</sup>

In reporting stationary test results, the method used to calculate the engine power, whether the vehicle was loaded or unloaded, and all recorded measurements are required.<sup>407</sup> The highest measurement is the test result.<sup>408</sup> In order to be considered valid, the difference between two consecutive measurements on the same side of the motor vehicle must not exceed 2 dB(A).<sup>409</sup>

Part II of the annex to the EEC Noise Emission Directive is entitled "Exhaust System (Silencer)."<sup>410</sup> All vehicles, as defined by article 1, are to be equipped with mufflers.<sup>411</sup> A drawing of the muffler is attached to the vehicle type-approval certificate.<sup>412</sup> Each muffler must be marked legibly and indelibly with its make and type.<sup>413</sup>

As a result of technical progress, part II of the annex to the EEC Noise Emission Directive was amended by the Exhaust System Amendment, which consists of a preamble, three articles and an annex.

The preamble to the Exhaust System Amendment explains that between 1970 and 1973 technology progressed to the point where it was "possible to test exhaust systems under conditions which correspond to their normal operating state in road traffic."<sup>414</sup> This development made an amendment of the existing requirements possible.

In article 1 the Council announced the substitution of the annex attached to the amendment for part II of the annex attached to the EEC Noise Emission Directive.<sup>415</sup> Article 2 provided for a staggered phase-in of the amendment.<sup>416</sup> Article 2 also re-

---

405. *Id.*

406. *Id.*

407. *Id.* annex § I.4.2.4.

408. *Id.*

409. *Id.*

410. In the German version of the EEC Noise Emission Directive, pt. II is entitled, "Auspuffvorrichtung (Schalldämpfer)."

411. EEC Noise Emission Directive, *supra* note 59, annex § II.1.

412. *Id.* annex § II.2.

413. *Id.* annex § II.3.

414. Exhaust System Amendment, *supra* note 60, preamble.

415. *Id.* art. 1.

416. *Id.* art. 2(1)-(3).

quired the member states to adopt and publish implementing provisions by March 1, 1974, and required the member states to inform the Commission when these steps had been taken.<sup>417</sup>

A compliance check can be carried out by selecting any one of the following methods: (1) continuous operation on the road for 10,000 kilometers/6214 miles,<sup>418</sup> (2) bench tests,<sup>419</sup> or (3) removal of the fibrous matter from the silencer.<sup>420</sup> In cases of dispute governed by article 8 of the Type-Approval Directive,<sup>421</sup> a bench test is the appropriate method.<sup>422</sup>

On June 20, 1973, and September 5, 1973, France and the United Kingdom, respectively, informed the Commission of their interest in substantially reducing the permissible sound levels found in part I of the annex to the EEC Noise Emission Directive.<sup>423</sup> The Commission subsequently received several inquiries concerning the possibility of reducing these limits.<sup>424</sup> On January 4, 1974, the Commission responded to these inquiries, stating that given the present state of technological progress, a reduction of approximately three decibels would be possible without any major modification in design.<sup>425</sup>

All this activity culminated in a Proposal "for a Council Directive modifying the Council Directive of 6 February 1970 on the approximation of the laws of the Member States relating to the permissible sound level and the exhaust system of motor vehicles" (Proposed Permissible Sound Level Amendment), which was submitted by the Commission to the Council on August 14, 1974.<sup>426</sup> In an explanatory memorandum accompanying the Proposed Permissible Sound Level Amendment, the Commission recommended both a short-term and a long-term program and indicated that its recommendations were based on consultations

417. *Id.* art. 2(4).

418. *Id.* annex § II.4.1.1.

419. *Id.* annex § II.4.1.2.

420. *Id.* annex § II.4.1.3.

421. *See* notes 205-07 and accompanying text *supra*.

422. Exhaust System Amendment, *supra* note 60, annex § II.5.

423. Commission of the European Communities, Explanatory Memorandum accompanying a Proposal for a Council Directive modifying the Council Directive of 6 February 1970 on the approximation of the laws of the Member States relating to the permissible sound level and the exhaust system of motor vehicles 1 (July 24, 1974) [hereinafter cited as Explanatory Memorandum].

424. *See, e.g.*, Written Question No. 411/73 from Mr. Müller and Mr. Kater to the Commission of the European Communities (Jan. 4, 1974) (copy in author's possession).

425. *Id.*

426. 17 O. J. EUR. COMM. (No. C 113) 67 (1974) [hereinafter cited as Proposed Permissible Sound Level Amendment].

with experts from the member states under the auspices of a working group responsible for the "Removal of Technical Barriers to Trade."<sup>427</sup>

The aim of the short-term program was to reduce the existing permissible sound levels without changing either the vehicle classification scheme or the test method.<sup>428</sup> Proposed reductions for some categories of the motor vehicles were more significant than for other categories. For example, the proposed reduction for buses was 4 dB(A), which represents a reduction of nearly fifty percent.<sup>429</sup> The aim of the long-term program was to find a new method of noise measurement. This new method was to "[reflect] the actual conditions in which vehicles are used in urban traffic."<sup>430</sup>

The Proposed Permissible Sound Level Amendment consisted of a preamble and four articles. Article 1 reduced the permissible sound levels for all types of motor vehicles.<sup>431</sup> The new permissible noise levels were to be phased in on a staggered basis under the provisions of article 2. Article 3 required member states to adopt and publish implementing provisions by October 1, 1975, and to inform the Commission when these steps had been taken.<sup>432</sup>

On September 2, 1974, the Council referred the Proposed Permissible Sound Level Amendment to the Parliament, and the Parliament rendered a favorable opinion.<sup>433</sup> In its opinion the Parliament specifically endorsed the combination of short-term and long-term programs approach to the noise problem.<sup>434</sup> An opinion of the Legal Affairs Committee attached to the opinion of the Parliament noted that "the proposal does not include a stipulation requiring the Member States to notify the Commission of any internal measures they intend to introduce."<sup>435</sup> The Parliament concluded that such a stipulation was unnecessary because

---

427. Explanatory Memorandum, *supra* note 423, at 1-2.

428. *Id.* at 2.

429. *Id.* Although the proposed reductions were significant, they were not as great as the Germans thought were feasible. The following reductions were recommended: (1) 5 dB(A) for automobiles, (2) 10 dB(A) for buses, and (3) 10 dB(A) for trucks. ENVIRONMENTAL REPORT, *supra* note 10, at 207, 221. According to the best estimates available, reducing bus noise emissions by 10 dB(A) would add 2-2.5% to the cost of manufacturing a bus. *Id.* at 221.

430. Explanatory Memorandum, *supra* note 423, at 2.

431. Proposed Permissible Sound Level Amendment, *supra* note 426, art. 1.

432. *Id.* art. 3.

433. [1974-1975] EUR. PARL. DOC. (No. 365) 5-6 (1974).

434. *Id.* at 14.

435. *Id.* at 16.

the proposal was of a transitory nature.<sup>436</sup> For the same reason, the Parliament concluded that the permissible noise level limits should be voluntary rather than mandatory.<sup>437</sup>

The Council referred the Proposed Permissible Sound Level Amendment to the Economic and Social Committee on September 3, 1974. On January 30, 1975, the Economic and Social Committee rendered a favorable opinion on the Proposed Permissible Sound Level Amendment.<sup>438</sup> The Economic and Social Committee approved a 2 dB(A) reduction for passenger motor vehicles, noting that "[a] mere 1 dB(A) reduction is equivalent to a 21% cut in . . . noise . . . [and] a reduction of 2 dB(A) amounts to 37% less noise," and also approved reductions of more than 2 dB(A) for the other categories of motor vehicles.<sup>439</sup>

The Economic and Social Committee also noted that the position of the motor vehicle industry had deteriorated since the Proposed Permissible Sound Level Amendment had been drawn up. Consequently, the Economic and Social Committee recommended that "Member States . . . carefully consider the stock issue . . . before stipulating the date from which the Member States may prohibit entry into service . . ." <sup>440</sup>

On March 8, 1977, the Council amended part I of the annex to the EEC Noise Emission Directive by adopting a new Council Directive: the Permissible Sound Level Amendment. Article 1 of this amendment substituted a new set of permissible sound level limits for the existing set of permissible sound level limits and those contained in the original Proposed Permissible Sound Level Amendment. Table V-1<sup>441</sup> shows existing, proposed, and amended limits.

436. *Id.* at 14.

437. *Id.*

438. 18 O.J. EUR. COMM. (No. C 62) 33 (1975).

439. *Id.* at 34.

440. *Id.*

441. Table V-1 is based on a table in the Permissible Sound Level Amendment, *supra* note 61, art. 1.

TABLE V-1

Vehicle Category	Permissible Sound Level (in dB(A))		
	Present Level	Proposed Level	Amended Level
1. Passenger vehicles with not more than nine seats including the driver's seat	82	80	80
2. Passenger vehicles with more than nine seats and having a maximum weight not exceeding 3.5 metric tons	84	81	81
3. Vehicles carrying goods and having a maximum weight not exceeding 3.5 metric tons	84	81	81
4. Passenger vehicles with more than nine seats and having a maximum weight exceeding 3.5 metric tons	89	85	82
5. Vehicles carrying goods and having a maximum weight exceeding 3.5 metric tons	89	86	86
6. Passenger vehicles with more than nine seats and having hp equal to or exceeding 200 hp	91	87	85
7. Vehicles carrying goods and having hp equal to or exceeding 200 hp and a maximum weight exceeding 12 metric tons	91	88	88

At a Motor Vehicle Symposium sponsored by the EEC in December 1975, the EEC Noise Emission Directive was hailed as the "strictest regulation of [its] type existing anywhere in the world."<sup>442</sup> Implementation of the EEC Noise Emission Directive has resulted in substantial reductions in the noise level throughout the EEC. Depending on the category of motor vehicle, the EEC estimates that there was a 6 to 10 dB(A) average drop in the noise level throughout the EEC between 1970 and 1975.<sup>443</sup>

442. EEC, Business Brief No. 287, at 2 (December 15, 1975) (copy in author's possession).

443. *Id.*

### 6. *Guidelines Governing Traffic Measures to Protect Sleep*

The Guidelines Governing Traffic Measures to Protect Sleep were issued by the Minister of Transportation on May 29, 1974. In his introduction to the guidelines, the Minister of Transportation stresses the limited role of traffic measures, requests that traffic measures be uniformly implemented throughout the Federal Republic of Germany,<sup>444</sup> and emphasizes the need for consultation and cooperation.

"Traffic measures to protect sleep should be considered when and so long as zoning, planning, or construction measures prove inadequate to protect sleeping individuals from unreasonable traffic noise."<sup>445</sup> Even if these other measures prove inadequate, state and local governments should not automatically respond to the situation by implementing traffic measures. Such action should always be preceded by weighing the advantages and disadvantages involved.<sup>446</sup> Caution should be exercised since traffic measures curtail the operator's freedom to operate a motor vehicle. Traffic measures should be the exception rather than the rule.<sup>447</sup>

Under these circumstances, consultation and cooperation are essential. All officials administering the Guidelines to Protect Sleep should consult with each other during the planning stage and cooperate with each other thereafter.<sup>448</sup> The police should also be involved.

The guidelines are divided into four sections. In addition, a report published by the Ministry of Transportation's Highway Construction Department<sup>449</sup> entitled "Noise Protection in Highway Construction" (Highway Construction Report)<sup>450</sup> is attached to the guidelines.

Section 1 of the Guidelines to Protect Sleep recites some commonly accepted information about traffic and traffic noise. The guidelines adopt "energy-equivalent continuous noise level" as their method of measuring traffic noise.<sup>451</sup> Energy-equivalent

444. Guidelines to Protect Sleep, *supra* note 40, preamble.

445. *Id.*

446. *Id.*

447. *Id.*

448. *Id.*

449. Abteilung Strassenbau.

450. Bundesminister für Verkehr, Abteilung Strassenbau, Lärmschutz im Strassenbau (1974) [hereinafter cited as Highway Construction Report], *reprinted in* 2 NOISE HANDBOOK, *supra* note 2, ¶ 30,033.

451. Guidelines to Protect Sleep, *supra* note 40, § 1.1. Energy-equivalent continuous

continuous noise level is measured in dB(A).

Section 45(1) of the StVO<sup>452</sup> authorizes the appropriate highway officials to take certain traffic measures to protect individuals who are sleeping. Officials can limit or prohibit traffic in residential areas and even reroute traffic.<sup>453</sup> Section 2 of the guidelines defines "residential areas" as (1) purely or generally residential areas in accordance with the Building Use Regulations,<sup>454</sup> (2) other areas which primarily and continuously serve as residential areas, and (3) residential areas established by older planning law.<sup>455</sup>

Traffic measures to protect sleep are subject to several limitations. They can only be imposed between 11:00 p.m. and 6:00 a.m.<sup>456</sup> and only if there is an energy-equivalent continuous sound level that exceeds 65 dB(A) between those hours.<sup>457</sup> Noise measurements or calculations should normally precede any decision to limit or prohibit traffic.<sup>458</sup> If the decision involves detouring traffic, the detour must be reasonable not only from the standpoint of the motorists but also from the standpoint of the residents along the new route.<sup>459</sup>

Section 3 discusses seven traffic measures designed to protect sleep. As a preface to those measures, the guidelines caution that traffic regulations provide a quick but usually only a temporary solution to a noise problem.<sup>460</sup> They also point out that traffic measures may be implemented for those time periods when permitted traffic produces an energy-equivalent continuous noise level in excess of 65 dB(A).<sup>461</sup>

a. *Traffic prohibitions.*<sup>462</sup> There is no condition precedent to

---

noise level and average noise level are synonymous. See ENVIRONMENTAL REPORT, *supra* note 10, at 192 n.1.

452. For a discussion of § 45(1) of the StVO, see notes 120-21 and accompanying text *supra*.

453. Guidelines to Protect Sleep, *supra* note 40, § 2.1.

454. Verordnung über die bauliche Nutzung der Grundstücke (Baunutzungsverordnung) (Building Use Regulations), Sept. 15, 1977, [1977] BGBl I 1763 [hereinafter cited as BauNVO], reprinted in 1 NOISE HANDBOOK, *supra* note 2, at ¶ 18,030. For a discussion of the BauNVO, see note 546 and accompanying text *infra*.

455. Guidelines to Protect Sleep, *supra* note 40, § 2.2.

456. *Id.* § 2.3.

457. *Id.* § 2.5.

458. *Id.* § 2.6. Section 2.6 refers the reader to the Highway Construction Report, *supra* note 450.

459. Guidelines to Protect Sleep, *supra* note 40, § 2.4.

460. *Id.* § 3.

461. *Id.*

462. Verkehrsverbote.



a prohibition on traffic.<sup>463</sup> However, traffic prohibitions usually are not considered unless a detour route exists and the detour does not merely result in a shifting of traffic noise from one route to another.<sup>464</sup>

*b. Traffic limitations for particular types of motor vehicles.*<sup>465</sup> Unlike traffic prohibitions, there is a condition precedent to a traffic limitation. Either a reasonable detour route must be offered or sufficient parking must be found.<sup>466</sup>

Prohibitions on truck traffic may reduce the noise level by as much as 10 dB(A).<sup>467</sup> Thus, trucks are a prime candidate for type limitation.<sup>468</sup> The guidelines, however, favor partial prohibitions—*e.g.*, for trucks of a certain weight category—rather than total prohibitions, particularly if the partial prohibition is all that is necessary to reach the desired noise level.<sup>469</sup>

In those cases where motor vehicles consistently produce unreasonable noise, the owner's cooperation should be requested. He may be asked to use other routes which will lower or eliminate the disturbance caused by his motor vehicles.<sup>470</sup> He may also be asked to limit the use of his motor vehicles during certain time periods.<sup>471</sup>

Certain motor vehicles require permits to operate. In the case of such vehicles, attention should be given to fines as a means of reducing noise and protecting sleep.<sup>472</sup>

*c. Shifts in traffic.*<sup>473</sup> Shifts in traffic are not recommended because they hamper traffic flow and because they simply move the problem to a different location.<sup>474</sup> One-way streets are an exception since one-way traffic produces less intensive and more homogeneous sound than two-way traffic.<sup>475</sup>

*d. Detours.*<sup>476</sup> A high degree of reasonableness is not a con-

463. Guidelines to Protect Sleep, *supra* note 40, § 3.1.

464. *Id.*

465. Verkehrsbeschränkungen für bestimmte Verkehrsarten.

466. Guidelines to Protect Sleep, *supra* note 40, § 3.2.

467. *Id.* § 3.2.1.

468. Noise emissions from one truck are approximately equivalent to noise emissions from 10 automobiles. ENVIRONMENTAL REPORT, *supra* note 10, at 221.

469. Guidelines to Protect Sleep, *supra* note 40, § 3.2.2.

470. *Id.* § 3.2.4.

471. *Id.*

472. *Id.* § 3.2.5.

473. Verkehrsverlagerungen.

474. Guidelines to Protect Sleep, *supra* note 40, § 3.3.1.

475. *Id.* § 3.3.2.

476. Umleitungen.

dition precedent to a detour.<sup>477</sup> Indeed, even long detours may be viewed as reasonable.<sup>478</sup>

*e. Traffic speed limitations.*<sup>479</sup> Traffic speed limitations should be ordered only after local conditions have been examined.<sup>480</sup> Reduction in traffic speed often results in an increase in the noise level. For example, reducing the traffic speed below 50 kmph/31 mph within community limits usually results in an increase in traffic noise because motor vehicles at that speed are required to operate in low gear.<sup>481</sup> A similar result occurs outside community limits.<sup>482</sup>

*f. The "green wave."*<sup>483</sup> The guidelines mention synchronized traffic signals, the so-called green wave, only in the context of evening-hour use. Careful attention should be given to the fact that traffic patterns and the number of motor vehicles are different during the evening hours than they are during the daylight hours.<sup>484</sup>

*g. Traffic signs.*<sup>485</sup> If a decision is made to implement a traffic prohibition, a traffic limitation, or a detour, a traffic sign must be posted.<sup>486</sup> The purpose of the traffic sign is to alert motorists to the traffic measure that has been implemented.

Section 4 outlines the scope of the Guidelines to Protect Sleep. The guidelines seek to protect sleep in residential areas during the evening hours.<sup>487</sup> In addition, limitations and prohibitions can be considered during the daylight hours when traffic measures are required to guarantee peace and quiet.<sup>488</sup>

The Highway Construction Report, attached to the guidelines, contains sections on "general information" and "specific information." The general information section indicates three factors that should be considered in judging noise. The first factor is intensity. "The louder the noise, the more disturbing."<sup>489</sup> Frequency or pitch is the second factor. "When the intensity of two

477. Guidelines to Protect Sleep, *supra* note 40, § 3.4.

478. *Id.*

479. Geschwindigkeitsbeschränkungen.

480. Guidelines to Protect Sleep, *supra* note 40, § 3.5.

481. *Id.* § 3.5.1. The guidelines, therefore, recommend that traffic speed, as a general rule, should not be reduced below 50 kmph/31 mph within community limits.

482. *Id.* § 3.5.2.

483. Grüne Welle.

484. Guidelines to Protect Sleep, *supra* note 40, § 3.6.

485. Verkehrszeichen.

486. Guidelines to Protect Sleep, *supra* note 40, § 3.7.

487. *Id.* § 4.

488. *Id.*

489. Highway Construction Report, *supra* note 450, § I(1).

sounds is identical, the sound with the higher frequency is more annoying."<sup>490</sup> The third factor is informational content. "A higher informational content leads to a higher level of disturbance."<sup>491</sup>

The general information section discusses the shift from DIN-phon to dB(A) and the use of energy-equivalent continuous noise levels. The Federal Republic of Germany initially used DIN-phon to measure noise levels. Because of the use of dB(A) elsewhere, it has now replaced DIN-phon. The general information section indicates that "there is no meaningful distinction between dB(A) and the Phon values."<sup>492</sup> Energy-equivalent continuous noise levels are used to measure noise levels over time.<sup>493</sup>

The specific information section is divided into three parts. Two tables are found in part one. Table V-2<sup>494</sup> shows the average energy-equivalent continuous noise level, expressed in dB(A), for various densities, expressed in motor vehicles per hour, when twenty percent of the motor vehicles are trucks and the motor vehicles are traveling at an average speed of 80 kmph/50 mph.

TABLE V-2

Density (motor vehicles per hour)	Noise Level (in dB(A)) Distance from the Highway		
	10 meters/ 32.8 feet	20 meters/ 65.6 feet	40 meters/ 131.2 feet
1,000	76	73	69
2,000	79	76	73
4,000	82	79	76
8,000	85	82	79

Noise emissions depend on speed and traffic mix. When the average speed is increased from 80 kmph/50 mph to 100 kmph/62 mph, the average energy-equivalent continuous noise level increases by 4 dB(A).<sup>495</sup> The comparable figure when the average speed is increased from 80 kmph/50 mph to 120 kmph/75 mph is 7 dB(A).<sup>496</sup> Between 60 kmph/37 mph and 80 kmph/50 mph, the

490. *Id.* § I(2).

491. *Id.* § I(3).

492. *Id.* § I.

493. *Id.*

494. Table V-2 is based on table 2 in the Highway Construction Report, *supra* note 450, § II(1).

495. *Id.* § II(1)(a).

496. *Id.*

average energy-equivalent continuous noise level is practically the same.<sup>497</sup>

The least amount of noise is produced between 40 kmph/25 mph and 60 kmph/37 mph when the number of trucks is significant and between 60 kmph/37 mph and 80 kmph/50 mph when the number of trucks is insignificant.<sup>498</sup> Because trucks are noisier than cars, a traffic mix of 20% trucks is 6 db(A) noisier than traffic which is solely made up of automobiles.<sup>499</sup> A traffic mix of 50% trucks is 8 dB(A) noisier, and a traffic mix of 100% trucks is 10 dB(A) noisier, than traffic which is solely made up of automobiles.<sup>500</sup>

Table V-3<sup>501</sup> demonstrates the relationship between highway surface and the ambient noise level.

TABLE V-3

Highway Surface	Ambient Noise Level (in dB(A))		
	60 kmph/ 37 mph	80 kmph/ 50 mph	100 kmph/ 62 mph
<b>Asphalt</b>			
Dry	70	75	79
Wet	80	82	84
<b>Cement</b>			
Dry	73	78	82
Wet	80	82	84

Part 2 discusses noise reduction possibilities. A noise reduction of up to 10 dB(A) can be achieved by traffic measures such as the planting of vegetation, depressed highways (up to 3 meters/9.8 feet), and low walls.<sup>502</sup> Noiseproof windows, thick plantings, high walls, and depressed highways (in excess of 3 meters/9.8 feet) are measures calculated to result in noise reductions of up to 20 dB(A).<sup>503</sup> In order to achieve noise reductions in excess of 20 dB(A), special windows, tunnels, muffling, very high walls, or a combination of the foregoing measures is recommended.<sup>504</sup>

497. *Id.*

498. *Id.*

499. *Id.* § II(1)(d).

500. *Id.*

501. Table V-3 is based on a table in the Highway Construction Report, *supra* note 450, § II(1)(f).

502. *Id.* § II(2).

503. *Id.*

504. *Id.*

Special attention is given to noiseproof windows. A closed regular window can result in a noise reduction of up to 15 dB(A), and a closed double window can result in a noise reduction of up to 25 dB(A). A noiseproof window, by comparison, can result in a noise reduction of 30 to 60 dB(A).<sup>505</sup>

In part 3 the costs of various noise reduction measures are outlined. Table V-4<sup>506</sup> summarizes these costs.

TABLE V-4

Noise Reduction	Cost	Noise Production Measures
0 - 5 dB(A)	up to DM 800,000/km	Traffic measures; plantings; walls
5 - 10 dB(A)	up to DM 1,500,000/km	Walls
10 - 15 dB(A)	up to DM 2,000,000/km	Walls; noiseproof windows
15 - 20 dB(A)	up to DM 3,000,000/km	Walls; troughs; noise-proof windows

### C. Phase Three: Ambient Noise Level Standards

The third and most recent phase in the development of traffic noise laws in the Federal Republic of Germany involves ambient noise level standards. Professor Lehmann at the Max Planck Institute for Labor Physiology in Dortmund did pioneering work with respect to ambient noise levels in the 1950's. He initially divided the noise spectrum into four stages.<sup>507</sup> He then assigned DIN-phon values<sup>508</sup> to each stage and described the reactions associated with each. Table V-5<sup>509</sup> summarizes Professor Lehmann's research.

505. *Id.* § II(2).

506. Table V-4 is based on a table found in the Highway Construction Report, *supra* note 450, § II(3).

507. ENVIRONMENTAL REPORT, *supra* note 10, at 191.

508. "DIN-phon values are generally equivalent to dB(A) values." *Id.* at 193 n.1.

509. Table V-5 is based on information found in the ENVIRONMENTAL REPORT, *supra* note 10, at 191, 193.

TABLE V-5

Stage	DIN-phon	Reactions
I	30 - 65	Only psychological
II	65 - 90	Psychological and vegetative
III	90 - 120	Increasing psychological and vegetative; danger of hearing damage
IV	above 120	Increasing psychological and vegetative; danger of hearing damage; effect on nerve cells

In the intervening years, several groups have been active in formulating ambient noise level standards. One such group is the Society of German Engineers (VDI).<sup>510</sup> VDI develops "guidelines."<sup>511</sup> Three of these guidelines are discussed below: VDI 2058-1/VDI 2058-2,<sup>512</sup> VDI 2719,<sup>513</sup> and VDI 2573.<sup>514</sup>

510. Verein Deutscher Ingenieure.

511. Richtlinien.

512. Verein Deutscher Ingenieure, VDI-Richtlinien 2058: Beurteilung und Abwehr von Arbeitslärm (Judging and Abating Industrial Noise) (July 1960). VDI 2058 was originally issued in July 1960. VDI subsequently decided that VDI 2058 should be revised and divided into two parts. The August 1968 version of VDI 2058-1 sparked considerable comment and criticism. As a result, this version was reworked and reissued in its present form in August 1971. Verein Deutscher Ingenieure, VDI-Richtlinien 2058-1: Beurteilung von Arbeitslärm in der Nachbarschaft (Judging Industrial Noise in the Adjacent Neighborhood) (Aug. 1971) [hereinafter cited as VDI 2058-1], *reprinted in 3 NOISE HANDBOOK, supra note 2, ¶ 48,225.*

The recommended ambient noise levels of VDI 2058-1 have been incorporated into the so-called Technical Introduction to Noise Control. See Allgemeine Verwaltungsvorschrift über genehmigungsbedürftige Anlagen nach § 16 der Gewerbeordnung—GewO—Technische Anleitung zum Schutz gegen Lärm (Technical Introduction to Noise Control), Jul. 16, 1968, [1968] BAAnz Nr. 137, *reprinted in 2 NOISE HANDBOOK, supra note 2, ¶ 34,035.*

In October 1970 VDI issued VDI 2058-2. Verein Deutscher Ingenieure, VDI-Richtlinien 2058-2: Beurteilung vom Arbeitslärm am Arbeitsplatz hinsichtlich Gehörschäden (Judging Industrial Noise in the Workplace, Emphasizing Hearing Loss) (Oct. 1970) [hereinafter cited as VDI 2058-2], *reprinted in 3 NOISE HANDBOOK, supra note 2, ¶ 48,226.*

513. Verein Deutscher Ingenieure, VDI-Richtlinien 2719: Schalldämmung von Fenstern (Noise Reduction Properties of Windows) (Oct. 1973) [hereinafter cited as VDI 2719], *reprinted in 3 NOISE HANDBOOK, supra note 2, ¶ 48,229.* VDI 2719 was issued in October 1973 by the VDI Ausschuss Wohnlärm (Section on Residential Noise) of the VDI-Kommission Lärminderung (Commission on Noise Abatement).

514. Verein Deutscher Ingenieure, VDI-Richtlinien 2573: Schutz gegen Verkehrslärm (Protecting Against Traffic Noise) (Feb. 1974) [hereinafter cited as VDI 2573], *reprinted in 3 NOISE HANDBOOK, supra note 2, ¶ 48,230.* VDI 2573 was issued in February 1974 by the VDI Section on Traffic Noise of the VDI Commission on Noise Abatement.

VDI 2058-1 recommends exterior and interior ambient noise levels for neighborhoods adjacent to industrial areas. Table V-6<sup>515</sup> summarizes the recommended exterior ambient noise levels.

TABLE V-6

Categories	Recommended Ambient Noise Levels (in dB(A))	
	Day	Night
1. Totally Industrial <sup>516</sup>	70	70
2. Mainly Industrial <sup>517</sup>	65	50
3. Mixed <sup>518</sup>	60	45
4. Mainly Residential <sup>519</sup>	55	40
5. Totally Residential <sup>520</sup>	50	35
6. Areas where hospitals, convalescent homes, and relaxation areas are located	45	35

If the interior area is a living area, the recommended interior ambient noise levels are 35 dB(A) during the day and 25 dB(A) at night, regardless of the location.<sup>521</sup> No interior ambient noise levels are recommended for areas other than living areas.<sup>522</sup>

Exterior noise peaks, even those of short duration, must be avoided if they exceed the daytime limit by 30 dB(A) or the nighttime limit by 20 dB(A).<sup>523</sup> The comparable figure for interior noise for both daytime and nighttime is 10 dB(A).<sup>524</sup>

VDI 2719 notes the increasing noise problem, particularly noise caused by motor vehicles; stresses that this problem can be partially solved by improving the contrast between exterior and interior noise levels; examines the role windows have to play in

515. Table V-6 is based on information in VDI 2058-1, *supra* note 512, § 3.3.1.

516. Compare category 1 of VDI 2058-1 with category 5 of DIN 18005, Table V-8 *infra*.

517. Compare category 2 of VDI 2058-1 with category 4 of DIN 18005, Table V-8 *infra*.

518. Compare category 3 of VDI 2058-1 with category 3 of DIN 18005, Table V-8 *infra*.

519. Compare category 4 of VDI 2058-1 with category 2 of DIN 18005, Table V-8 *infra*.

520. Compare category 5 of VDI 2058-1 with category 1 of DIN 18005, Table V-8 *infra*.

521. VDI 2058-1, *supra* note 512, § 3.3.2.

522. An office is an example of an area which is not a living area. Section 3.3.2 indicates that a VDI 2058-3 is being prepared and that this part will address itself to the problem of interior ambient noise levels in areas other than living areas. *Id.*

523. *Id.* § 3.3.1.

524. *Id.* § 3.3.2.

achieving this goal; and recommends an average noise level and an average maximum noise level for various types of rooms. Table V-7<sup>525</sup> summarizes the recommended levels.

TABLE V-7

Type of Room	Average Noise Level (in dB(A))	Average Maximum Noise Level (in dB(A))
<b>Bedroom (nighttime)<sup>526</sup></b>		
Residential or area deserving protection	25 - 30	35 - 40
Other	30 - 35	40 - 45
<b>Living areas (Daytime)<sup>527</sup></b>		
Residential or area deserving protection	30 - 35	40 - 45
Other	35 - 40	45 - 50
<b>Communication or workrooms</b>		
Schoolroom, singles offices, scientific workrooms, libraries, conference and meeting rooms, doctor's office	30 - 40	40 - 50
Offices of several people	35 - 45	45 - 55
Large offices	40 - 50	50 - 60

525. Table V-7 is based on table 5 in VDI 2719, *supra* note 513. The average maximum noise level for residential areas in VDI 2719 is not identical with the recommended ambient noise levels for either totally residential areas or mainly residential areas in VDI 2058-1. Compare Table V-7 with Table V-8. Note should be taken that the measurement techniques in VDI 2058-1 and VDI 2719 differ. VDI 2719 is an interior measurement where the microphone is placed in the middle of the room. In contrast, the measurement in VDI 2058-1 is an exterior measurement where the microphone is placed 0.5 m./1.6 ft. in front of an open window. The *Environmental Report* indicates that at least 5 dB(A) should be added to the average maximum noise levels in VDI 2719 in order to compensate for this difference. ENVIRONMENTAL REPORT, *supra* note 10, at 197. If 5 dB(A) is added, there is practically no difference between VDI 2058-1 and VDI 2719.

526. Nighttime is the period from 10:00 p.m. to 6:00 a.m. This definition is identical to the definition in the regulations promulgated under the StVO. See note 100 and accompanying text *supra*. But see Guidelines to Protect Sleep, *supra* note 40, § 2.3.

527. Daytime is the period from 6:00 a.m. to 10:00 p.m. According to a footnote to table 5 of VDI 2719, the difference between daytime levels and nighttime levels is 5 dB(A). The residential daytime level, for example, is 30-35 dB(A), and the nighttime level is 25-30 dB(A). If 5 dB(A) is subtracted from the daytime level, the daytime and nighttime levels recommended by VDI 2719 are identical. See note 100 and accompanying text *supra*.



Another group that has been active in the formulation of ambient noise levels is the German Norm Commission (DNA).<sup>528</sup> DNA develops "norms" (DIN). DIN 18005,<sup>529</sup> an "advisory" norm, establishes six land-use categories and recommends ambient noise levels for each category. Table V-8<sup>530</sup> summarizes the recommended ambient noise levels for planning purposes.

TABLE V-8

Land-Use Category	Recommended Ambient Noise Levels (in dB(A))	
	Day	Night
1. Pure residential; weekend area	50	35
2. General residential; small housing	55	40
3. Village; mixed	60	45
4. Central; business	65	50
5. Industrial	70	70
6. Special	45 - 70	45 - 70

DIN 18005 recognizes that different land-use areas may border each other and that the recommended ambient noise levels for planning purposes may on occasion be exceeded. However, an actual noise level which exceeds the recommended noise level by more than 10 dB(A) should only be permitted as a special exception.<sup>531</sup>

In response to the activities of individuals like Professor Lehmann and professional groups like VDI and DNA, and as a result of its own initiative, the Federal Republic of Germany has enacted two categories of legislation. One category is specific and requires that ambient noise level standards be established. The Federal Ambient Levels Protection Law (BlmSchG)<sup>532</sup> is an ex-

528. Deutscher Normenausschuss.

529. Deutscher Normenausschuss, DIN 18005, Blatt 1: Vornorm, Schallschutz in Städtebau: Hinweise für die Planung; Berechnungs- und Bewertungsgrundlagen (Noise Abatement in Town Planning: Recommendations for Planning; Calculation and Rating Principles) (May 1971) [hereinafter cited as DIN 18005], reprinted in 3 NOISE HANDBOOK, *supra* note 2, ¶ 48,037.

530. Table V-8 is based on table 4 in DIN 18005, *supra* note 529.

531. *Id.* at 13.

532. BlmSchG, *supra* note 71.

ample of such legislation. Another category is more general and simply requires that some attention be given to ambient noise levels. This category includes the Federal Building Law (BBauG),<sup>533</sup> the Zoning Law (ROG),<sup>534</sup> the Federal Highway Law (FStrG),<sup>535</sup> and the Building Use Regulations (BauNVO).<sup>536</sup>

No attempt will be made to closely examine the second, more generalized category. Rather, those aspects which are relevant to the discussion of traffic noise will be highlighted.

### 1. General legislation

a. *Zoning Law (ROG)*. The ROG consists of seven sections. Section 1 states that the goal of zoning is to develop the Federal Republic of Germany in a manner which serves the best interests of the free development of each individual within society.<sup>537</sup>

In section 2 certain "general principles" are articulated. One of the principles is that the purpose of zoning is to insure and to encourage development which enhances the quality of life and improves working conditions.<sup>538</sup> In particular, adequate attention must be given to protecting the general public from noise disturbances.<sup>539</sup>

Conflicts involving general principles are possible. If such a conflict arises, the appropriate federal or state planning officials are to use their best judgment in resolving the conflict in accordance with section 1.<sup>540</sup> States, moreover, are free to establish additional general principles so long as they do not contradict section 1.<sup>541</sup>

b. *Federal Building Law (BBauG)*. The BBauG consists of 189 sections divided into eleven parts. The BBauG is similar to American zoning law in that each community prepares a master plan<sup>542</sup> to govern development within the community and build-

533. Bundesbaugesetz (Federal Building Law), June 23, 1960, [1960] BGBl I 341, as amended by Law of Aug. 18, 1976, [1976] BGBl I 2221 [hereinafter cited as BBauG]. Selected excerpts are reprinted in 1 NOISE HANDBOOK, *supra* note 2, ¶ 18,025.

534. Raumordnungsgesetz (Zoning Law), Apr. 8, 1965, [1965] BGBl I 306 [hereinafter cited as ROG]. Selected excerpts are reprinted in 1 NOISE HANDBOOK, *supra* note 2, ¶ 17,025.

535. Bundesfernstrassengesetz (Federal Highway Law), Oct. 1, 1974, [1974] BGBl I 2413 [hereinafter cited as FStrG], reprinted in 1 NOISE HANDBOOK, *supra* note 2, ¶ 19,025.

536. BauNVO, *supra* note 454.

537. ROG, *supra* note 534, § 1(1).

538. *Id.* § 2(1)(1).

539. *Id.* § 2(1)(7).

540. *Id.* § 2(3).

541. *Id.* § 2(2).

542. The German term for master plan is Flächennutzungsplan.

ing plans<sup>543</sup> are not approved unless they comply with the requirements of the master plan. No section in the BBauG mentions noise specifically. Section 1, however, requires that building plans insure an environment worthy of human habitation and give attention to the importance of protecting the environment.<sup>544</sup> In section 5 the content of master plans is discussed. Master plans must show the expected needs of the members of the community and the manner in which the community will be developed to meet those needs.<sup>545</sup>

c. *Building Use Regulations (BauNVO)*. The BauNVO consists of twenty-seven sections divided into five chapters. Section 1 establishes ten land-use categories: small housing, pure residential, general residential, special residential, village, mixed, central, business, industrial, and special.<sup>546</sup> DIN 18005 borrowed these land-use categories<sup>547</sup> and assigned a recommended ambient noise level to each.<sup>548</sup>

d. *Federal Highway Law (FStrG)*. The FStrG consists of twenty-seven sections. Section 1 describes the federal highway system<sup>549</sup> and declares that noise abatement measures are an integral part of that system.<sup>550</sup>

The Minister of Transportation is authorized by section 16 to determine when and where federal highways will be constructed.<sup>551</sup> In making this determination, he must secure the "consent" of those officials responsible for zoning matters in other ministries and the "agreement" of the planning officials in the states affected by this determination.<sup>552</sup>

If local or state planning officials wish to alter an existing

543. The German term for building plans is Bauleitpläne.

544. BBauG, *supra* note 533, § 1(6).

545. *Id.* § 5(1).

546. BauNVO, *supra* note 454, §§ 1(2)-10.

547. The land-use categories in the current version of the BauNVO are slightly different from the land-use categories in the 1968 version. The 1968 version had "weekend area" zones. These zones are now part of the special zones. The current version has a special residential zone. There were no special residential zones in the 1968 version.

DIN 18005, *supra* note 529, which was published in 1971, borrowed the land-use categories of the 1968 version of the BauNVO. Hence, there are minor differences between DIN 18005 and the BauNVO. The BauNVO is an example of action rather than reaction on the part of the federal government. The BauNVO preceded DIN 18005 by three years.

548. See Table V-8 *supra*.

549. The federal highway system is composed of federal freeways (Bundesautobahnen) and federal highways that pass through communities (Bundesstrassen mit den Ortsdurchfahrten). See FStrG, *supra* note 535, § 1(2).

550. *Id.* § 1(4)(1).

551. *Id.* § 16(1).

552. *Id.*

federal highway or construct a new federal highway, officials of the Highway Construction Department must be involved in the decisionmaking process to represent the interests of the federal government.<sup>553</sup> If there is a conflict between the federal interest and the state or local interest, the federal interest prevails.<sup>554</sup>

Section 17 imposes on the entity responsible for constructing the federal highway—either the federal government or a local government<sup>555</sup>—the responsibility of specifying in the final plans those abatement measures that will be constructed and maintained in order to protect the public interest and land adjacent to the federal highway from unreasonable disturbances.<sup>556</sup> A distinction has been drawn between unreasonable disturbances existing at the time the final plans are being prepared and those arising after the final plans have been approved. If the unreasonable disturbances exist at the time the final plans are being prepared, the affected party has a cause of action for damages against the entity constructing the federal highway, provided the noise abatement measures and the final plans are incompatible or the costs of the noise abatement measures are out of proportion to the benefits to be derived.<sup>557</sup> These uses are unaffected by sections 41 and 42 of the BImSchG.<sup>558</sup>

If the unreasonable disturbance arises after the final plans have been approved, the situation is more complex because approved final plans, as a general rule, are not subject to attack.<sup>559</sup> Unreasonable disturbances arising after approval are an exception to the rule. The affected party's first recourse is to request that noise abatement measures be taken.<sup>560</sup> If the noise abatement measures and the approved final plans are incompatible or the costs of the noise abatement measures are prohibitive, his second recourse is a cause of action for damages against the entity constructing the federal highway.<sup>561</sup> Section 42 of the BImSchG is applicable in such cases.<sup>562</sup>

Requests to take noise abatement measures or claims for

---

553. *Id.* § 16(2).

554. *Id.*

555. *Id.* § 5.

556. *Id.* § 17(4).

557. *Id.*

558. *Id.* For a discussion of §§ 41 and 42 of the BImSchG, see notes 599-610 and accompanying text *infra*.

559. FStrG, *supra* note 535, § 17(6).

560. *Id.*

561. *Id.*

562. *Id.*

damages must be submitted in writing to the appropriate planning authorities.<sup>563</sup> A three-year statute of limitations applies to new construction and a thirty-year statute of limitations applies to existing projects.<sup>564</sup>

The federal government has attempted to enact ambient noise level standards governing property adjacent to highways. One approach has been to amend the FStrG. For example, a Draft Amendment of the FStrG<sup>565</sup> establishing an ambient noise level standard of 75 dB(A)<sup>566</sup> for property adjacent to highways was introduced on March 23, 1973. All attempts to amend the FStrG by incorporating a specific ambient noise level standard have been unsuccessful.

Since the amendment was unsuccessful, resulting in no ambient noise level standards for highways,<sup>567</sup> and since "the damage to environmental quality associated with highway projects frequently assumes higher priority than the use to which the highway project will be put,"<sup>568</sup> the federal government has tried another approach: a separate ambient noise level law for highways. On March 23, 1978, the federal government submitted a Draft Traffic Noise Protection Law (Draft VLärmSchG)<sup>569</sup> to the Bundesrat.

The purpose of the Draft VLärmSchG is to prevent an increase in ambient noise levels resulting from the construction of new highway projects when the ambient noise level after the increase exceeds a predetermined ambient noise level standard or

563. *Id.* § 17(7).

564. *Id.*

565. Entwurf eines 2. Gesetzes zur Änderung des Bundesfernstrassengesetzes.

566. The *Environmental Report* indicates that 75 dB(A) should be viewed as "an economically-based proposal" rather than "a standard of possible noise abatement." ENVIRONMENTAL REPORT, *supra* note 10, at 197.

567. Begründung zum Entwurf eines Gesetzes zum Schutz gegen Verkehrslärm an Strassen und Schienenwegen—Verkehrslärmschutzgesetz (VLärmSchG), Drucksache 8/1671, Deutscher Bundestag, 8. Wahlperiode, at 19 (1978) [hereinafter cited as Background Document for the Draft Traffic Noise Law].

According to the Background Document for the Draft Traffic Noise Law, the absence of ambient noise level standards has caused legal and practical problems in the planning and construction of highways. It is advisable to eliminate the existing legal uncertainties and, by means of defined legal standards, to make clear to the federal, state, and local planning authorities in which cases noise abatement measures are necessary and to citizens when they can demand such measures. In establishing ambient noise level standards, a balance must be struck between the need for noise protection measures and their cost. This decision, because of its significance, must be made by the legislature. *Id.*

568. *Id.*

569. Entwurf eines Gesetzes zum Schutz gegen Verkehrslärm an Strassen und Schienenwegen—Verkehrslärmschutzgesetz (Draft Traffic Noise Law), Drucksache 8/1671, Bundestag, 8. Wahlperiode [hereinafter cited as Draft VLärmSchG].

a change in ambient noise levels resulting from a modification in an existing highway project when such a change is substantial. Table V-9<sup>570</sup> summarizes the ambient noise level standards the Draft VLärmSchG currently proposes to establish.

TABLE V-9

Land-Use Category <sup>571</sup>	Ambient Noise Level Standards (in dB(A))	
	Daytime <sup>572</sup>	Nighttime <sup>573</sup>
Pure residential, general residential, small housing	62	52
Central, village, mixed, special residential	67	57
Business, industrial	72	62

The Draft VLärmSchG defines a change in ambient noise levels as substantial if the average noise level increases 3 dB(A)<sup>574</sup> or the average noise level exceeds 75 dB(A) during the day or 65 dB(A) during the night.<sup>575</sup>

If a highway project produces ambient noise levels exceeding these standards or causes a substantial change, the entity constructing the highway project must take whatever noise abatement measures are necessary to correct the situation.<sup>576</sup> The entity constructing the highway project is freed from this obligation if the noise abatement measures are not feasible<sup>577</sup> or their cost is

570. Table V-9 is based on information in the Draft VLärmSchG. See COMM. MKT. REP. (CCH), *Euromarket News*, Rep. No. 385, at 5 (Dec. 12, 1979).

571. The land-use categories in the Draft VLärmSchG were borrowed from the BauNVO. See Background Document for the Draft Traffic Noise Law, *supra* note 567, at 21.

There is only one minor difference between the Draft VLärmSchG and the BauNVO. The BauNVO has a special zone; the Draft VLärmSchG has no such zone. According to the Background Document for the Draft Traffic Noise Law, special zones are merged into one of the other two land-use categories in the Draft VLärmSchG depending on the purpose to which the special zone is being put. *Id.*

572. Daytime is the period from 6:00 a.m. to 10:00 p.m. Draft VLärmSchG, *supra* note 569, § 1(2). Compare *id.* with Regulations, *supra* note 32, § 30(2)(I) and VDI 2719, note 513 *supra*. But see Guidelines to Protect Sleep, note 40 *supra*.

573. Nighttime is the period from 10:00 p.m. to 6:00 a.m. Draft VLärmSchG *supra* note 569, § 1(2).

574. An increase of 3 dB(A) is equivalent to a doubling in the amount of traffic and is deemed to be so significant that noise abatement measures are required. Background Document for the Draft Traffic Noise Law, *supra* note 567, at 20.

575. Draft VLärmSchG, *supra* note 569, § 1(3).

576. *Id.* § 1(1).

577. Measures are not feasible if they are not technically possible or technically

out of proportion to the benefits to be derived.<sup>578</sup> In such cases, the affected party has a cause of action for damages against the entity constructing the highway project.<sup>579</sup>

The federal government estimates that the annual cost of the Draft VLärmSchG will be approximately DM 830 million.<sup>580</sup> Nearly half of the total annual cost—DM 350 million—would be allocated to local highway noise abatement measures.<sup>581</sup> Noise abatement measures along federal highways would require DM 410 million,<sup>582</sup> while state highway noise abatement measures would require DM 70 million.<sup>583</sup>

## 2. *Specific legislation: Federal Ambient Levels Protection Law (BImSchG)*

On March 14, 1974, the Bundestag, with the concurrence of the Bundesrat, enacted the BImSchG. The BImSchG is divided into seven parts: (1) general regulations; (2) construction and operation of installations; (3) nature of installations, substances, products, and fuels; (4) nature and operation of motor vehicles and construction of highways and rail systems; (5) supervision of air pollution and air pollution plans in the Federal Republic of Germany; (6) common regulations; and (7) concluding regulations. Although motor vehicle noise is not the primary focus of the BImSchG, there are several important provisions in the BImSchG that apply to motor vehicle noise.

General regulations are found in part 1, which consists of three sections. Section 1 states the BImSchG's purpose: "The purpose of this law is to protect human beings, as well as animals, plants and other objects, from harmful environmental effects . . . and to prevent the occurrence of such effects."<sup>584</sup> In more specific terms, the BImSchG's purpose is to limit or prevent the occur-

sufficient. See Background Document for the Draft Traffic Noise Law, *supra* note 567, at 20. Measures are not feasible "when their achievement too strongly undermines other public needs . . . such as city planning or protecting the landscape." *Id.*

578. Draft VLärmSchG, *supra* note 569, § 2(1). In determining whether proportionality exists, attention should be given to the purpose to which the affected property is being put. See Background Document for the Draft Traffic Noise Law, *supra* note 567, at 20.

579. Draft VLärmSchG, *supra* note 569, § 2(1). The Draft VLärmSchG places limitations on the right to a cause of action for damages. See *id.* § 2(2), (3).

580. Compare Background Document for the Draft Traffic Noise Law, *supra* note 567, at 19 with COMM. MKT. REP. (CCH), *Euromarket News*, Rep. No. 385, at 5-6 (Dec. 12, 1979).

581. *Id.*

582. The DM 410 million figure can be broken down into two components: DM 270 million for new highways, DM 140 million for existing highways. The federal government anticipates that 20 years will be required to put existing highways in order. *Id.*

583. *Id.*

584. BImSchG, *supra* note 71, § 1.

rence of dangers, serious disadvantages, and serious disturbances arising from the operation of "installations"<sup>585</sup> that require a permit to operate.<sup>586</sup> Only certain installations, substances, products, and fuels come within the scope of the BImSchG as described in section 2.<sup>587</sup>

Section 3 contains definitions. "Installation" is a term frequently used throughout the BImSchG. As a general rule, motor vehicles are not installations. The general definition of installation, however, includes "machines, instruments, and other technical equipment which can cause changes in a local area, as well as motor vehicles, so long as these categories [of installations] are not subject to section 38."<sup>588</sup> Section 3 distinguishes emission levels<sup>589</sup> from ambient levels.<sup>590</sup> Ambient levels are equal to the sum of the emission levels in a given area. Ambient levels may constitute a harmful environmental effect because "their nature, amount, or duration has the capacity to cause danger, serious disadvantages, or serious disturbances to the population in general or to a particular neighborhood."<sup>591</sup> "Best available technology" is "that state of development which corresponds with *progressive* procedures, equipment, or manner of operation which assures that the measures taken will limit emissions."<sup>592</sup>

Part 4, consisting of six sections, deals not only with the nature and operation of motor vehicles but also with the construc-

585. For a definition of "installation" as that term is used in the BImSchG, see note 588 and accompanying text *infra*.

586. BImSchG, *supra* note 71, § 1.

587. *Id.* § 2(1), (3), (4). There are a number of installations, substances, products, and fuels that fall outside the scope of the BImSchG. For example, the BImSchG does not govern installations, instruments, devices, or nuclear fuels and other radioactive substances that are subject to the Atomic Energy Law or regulations issued pursuant thereto. Law of Dec. 23, 1959, [1959] BGBl I 814, *as amended* by Law of June 23, 1970, [1970] BGBl I 805.

588. BImSchG, *supra* note 71, § 3(5)(2).

589. "Emission levels . . . are the levels of air pollution, noise, vibration, light, heat and similar effects produced by a particular source." BImSchG, *supra* note 71, § 3(3).

590. "Ambient Levels . . . are the levels of air pollution, noise, vibration, light, heat, rays and similar environmental effects which affect human beings as well as animals, plants and other objects." *Id.* § 3(2).

591. *Id.* § 3(1).

592. *Id.* § 3(5)-(6) (emphasis added). Section 3(5)-(6) dictates a progressive standard of best available technology. Under this standard, the loudest product, even if within the parameters of best available technology, is suspect. The standard of best available technology is incorporated into § 41. See note 600 and accompanying text *infra*. Section 38, however, does not mention the standard of best available technology. See notes 593-96 and accompanying text *infra*.



tion and modification of highways and rail systems. "Motor vehicles and their trailers [according to section 38] . . . must be constructed so that when they are operated in the necessary appointed manner their emissions do not exceed a level which is necessary in order to protect against harmful environmental effects."<sup>593</sup> Moreover, "[t]hey must be operated so that avoidable emissions are prevented and unavoidable emissions are reduced to the lowest possible level."<sup>594</sup>

Sections 38 and 70 authorize the Minister of Transportation and the Minister of the Interior to determine requirements for manufacturing, equipping, operating, and testing motor vehicles necessary to avoid harmful environmental effects and to issue regulations consistent with these determinations.<sup>595</sup> No regulations should be issued before "interested persons" are consulted.<sup>596</sup>

Since the Federal Republic of Germany is a party to bilateral and multilateral agreements, section 39 authorizes the Minister of Transportation and the Minister of the Interior to discharge any responsibilities arising under agreements between the Federal Republic of Germany and other states or pursuant to a binding EEC directive by issuing appropriate regulations.<sup>597</sup> Regulations that contain specific requirements for constructing, equipping, testing, and operating motor vehicles require the concurrence of the Bundesrat.<sup>598</sup>

Section 41 provides for a determination separate and distinct from the planning measures mandated by section 50.<sup>599</sup> Section 41 provides that construction or significant modification of a highway must not cause any harmful environmental effects which are technologically avoidable,<sup>600</sup> unless the cost of the technology

---

593. BImSchG, *supra* note 71, § 38.

594. *Id.*

595. *Id.*

596. *Id.*

597. *Id.* § 39.

598. *Id.*

599. For a discussion of § 50 of the BImSchG, see note 613 and accompanying text *infra*.

600. BImSchG, *supra* note 71, § 41(1). Note should be taken that § 41 is restricted to new construction or significant modification. The term "significant modification" is not defined in the BImSchG. As a result, certain ambiguities will have to be resolved. Suppose, for example, that a local street becomes a highway. Does this change constitute a significant modification within the meaning of that term as used in the BImSchG? Perhaps the Draft VLärmSchG, if enacted, will clarify some of these ambiguities because it defines "significant change." See notes 574-75 and accompanying text *supra*.

is greater than the benefits to be derived.<sup>601</sup>

If a highway is constructed or significantly modified and the resultant ambient noise level exceeds the permissible ambient noise level established by section 43(1)(1),<sup>602</sup> the owner of the affected installation has a cause of action for damages under section 42, except in those cases where the injury can be reasonably traced to the particular use to which the affected installation is being put.<sup>603</sup> The provisions of section 42 not only apply where the installation is in place when the public highway is constructed or significantly modified but also where building plans have been approved and a building permit for a proposed installation has been granted when the public highway is constructed or significantly modified, provided the plans show a highway or a proposed highway in the vicinity of the proposed installation.<sup>604</sup>

Damages can be awarded to the owner of the affected installation in an amount equal to the expenses incurred for noise abatement measures, provided these damages are within the limitations set by section 43(1)(3).<sup>605</sup> Regulations that permit even greater damages remain unaffected.<sup>606</sup>

If the owner of the affected installation and the entity constructing or significantly modifying the highway are unable to reach agreement on the amount of the damages, one of the parties may request state officials to determine the amount of the damages.<sup>607</sup> State eminent domain procedure governs in all other cases.<sup>608</sup>

Section 43 authorizes the executive branch of the federal government to issue regulations implementing sections 41 and 42 after consultation with interested persons and subject to the concurrence of the Bundesrat.<sup>609</sup> In particular, this authorization comprehends

1. permissible noise limits which may not be exceeded in order to protect the neighborhood from the harmful effects of noise as

---

601. BImSchG, *supra* note 71, § 41(2).

602. For a discussion of § 43(1)(1) of the BImSchG, see notes 609-10 and accompanying text *infra*. (Implementing regulations that contain ambient noise levels have not been issued.)

603. BImSchG, *supra* note 71, § 42(1).

604. *Id.*

605. *Id.* § 42(2). For a discussion of § 43(1)(3) of the BImSchG, see notes 609-10 and accompanying text *infra*.

606. BImSchG, *supra* note 71, § 42(2).

607. *Id.* § 42(3).

608. *Id.*

609. *Id.* § 43(1).

well as the procedures to determine emission levels and ambient levels,

2. technical requirements for the construction of public highways . . . so as to minimize the harmful environmental effects of noise and

3. nature and scope of the noise abatement measures on installations which are necessary to protect against the harmful environmental effects of noise.<sup>610</sup>

Common regulations are found in part 6, which consists of eighteen sections. After consultation with interested persons and subject to the concurrence of the Bundesrat, section 48 empowers the executive branch of the federal government to issue general administrative regulations enforcing the BImSchG.<sup>611</sup> The following categories of general administrative regulations are specifically mentioned: ambient level standards, emission level standards, and testing standards to determine ambient and emission levels.<sup>612</sup>

In cases involving plans or measures that are significant in spatial terms, section 50 requires that the affected areas be organized in terms of land use.<sup>613</sup> The purpose of such organization is to avoid harmful environmental effects.<sup>614</sup>

Section 51 requires that interested persons be consulted before certain regulations can be issued. Interested persons include "technical representatives, the affected party, the interested industry, highway personnel, and the highest state officials who are responsible for controlling ambient levels."<sup>615</sup> Obviously, the interested persons vary from case to case.

Section 61 requires the executive branch of the federal government to report to the Bundestag annually concerning the following matters:

1. [S]tatus and development of harmful environmental effects caused by air pollution and noise in the Federal Republic of Germany during the report period as well as anticipated further developments,
2. actual and anticipated measures used to enforce [the BImSchG],

---

610. *Id.* § 43(1)(1)-(3).

611. *Id.* § 48.

612. *Id.* § 48(1)-(3).

613. *Id.* § 50.

614. *Id.*

615. *Id.* § 51.

3. continuing and anticipated studies with respect to the effects of air pollution and noise,
4. development of technical procedures and equipment to minimize the harmful environmental effects caused by air pollution and noise and
5. federal and state resources being used for research and development of the purposes outlined in 3 and 4.<sup>616</sup>

Violations of regulations issued pursuant to sections 38(4) or 39 are administrative offenses, provided the regulations invoke section 62.<sup>617</sup> In such cases a fine of DM 100,000 may be levied.<sup>618</sup>

#### *D. Enforcement*

Noise regulation is a concurrent power under the Constitution.<sup>619</sup> At the federal level, two ministries—the Ministry of Transportation (BMV)<sup>620</sup> and the Ministry of Interior (BMI)<sup>621</sup>—are primarily responsible for regulating noise.

BMV's responsibilities are technical in nature. BMV, for example, issued the Muffler Replacement Regulations,<sup>622</sup> the German Noise Emission Guidelines,<sup>623</sup> the Guidelines Governing Traffic Measures to Protect Sleep,<sup>624</sup> and the Primary Test,<sup>625</sup> Intermediate Test,<sup>626</sup> and Close-Range Stationary Measurement Guidelines.<sup>627</sup>

BMI's responsibilities are more general in nature. BMI drafts noise laws, ordinances, regulations, and guidelines and acts as liaison between the federal government and the EEC. In 1974 a Federal Office of Environmental Affairs (UBA)<sup>628</sup> was established to collect information, provide technical support, and commis-

616. *Id.* § 61(1)-(5).

617. *Id.* § 62(1)(7).

618. *Id.* § 62(3). DM 100,000 is equivalent to approximately \$50,000.

619. See notes 5-9 and accompanying text *supra*.

620. Bundesministerium für Verkehr.

621. Bundesministerium des Innern.

622. See notes 348-51 and accompanying text *supra*.

623. See note 352 and accompanying text *supra*.

624. See notes 444-506 and accompanying text *supra*.

625. See notes 233-34 and accompanying text *supra*.

626. See notes 235-38 and accompanying text *supra*.

627. See notes 353-65 and accompanying text *supra*.

628. Umweltbundesamt. A president supervises the activities of UBA. He is assisted by a Rat von Sachverständigen für Umweltfragen (Council of Experts on Environmental Questions). BMI announced the creation of this council in 1971. See Erlass des Bundesministers des Innern über die Einrichtung eines Rates von Sachverständigen für Umweltfragen bei dem Bundesminister des Innern, Dec. 28, 1971 [1971] BAnz Nr. 8, reprinted in 1 NOISE HANDBOOK, *supra* note 2, ¶ 27,035.

629. The legislature passed two laws in 1974. One established UBA. Law of July 22,

sion research.<sup>629</sup> UBA is divided into a Central Division<sup>630</sup> and three subject areas.<sup>631</sup> Ambient Levels Control, one of the subject areas, is divided into three area groups<sup>632</sup> and ten subgroups.<sup>633</sup>

A section of BMI, which existed at the time UBA was created and which deals with environmental matters, continue to function through two subsections. One of these subsections includes a noise group.<sup>634</sup> Five individuals are employed in this noise group.<sup>635</sup> Two are physicists, two are administrators, and one is an attorney.<sup>636</sup>

Under this scheme, enforcement responsibilities are fragmented. They are further fragmented because the states as well as the federal government are active in regulating traffic noise. Indeed, state governments are responsible for most of the enforcement. Such fragmentation undermines the enforcement effort. The federal government estimates that there are more than 3000 serious violations of environmental statutes annually but has no idea how many of these violators are brought to trial or fined.<sup>637</sup> In order to improve the current situation, the federal government recently submitted draft legislation that would transfer various existing environmental statutes imposing severe penalties in

1974, [1974] BGBl I 1505, reprinted in 1 NOISE HANDBOOK, *supra* note 2, ¶ 27,025. Another provided for the collection of environmental statistics. Law of Aug. 15, 1974, [1974] BGBl I 1938, reprinted in 1 NOISE HANDBOOK, *supra* note 2, ¶ 27,027.

630. Zentralabteilung.

631. The three subject areas are: Fachbereich I—Allgemeine Umweltangelegenheiten (General Environmental Matters); Fachbereich II—Immissionsschutz (Ambient Levels Control); and Fachbereich III—Abfallwirtschaft (Solid Waste).

632. The three area groups are: Fachgruppe Luftreinhaltung (Air Pollution); Fachgruppe Lärm/Erschütterungen (Noise/Vibration); and Fachgruppe Wirkungen Luft/Lärm/Erschütterungen (Effects of Air Pollution/Noise/Vibration).

633. The ten subgroups are: Gruppe II 1—Allgemeine Aufgaben, Laboratorien (General Matters/Laboratory); Gruppe II 2—Verfahren der Luftreinhaltung Industrie/Verkehr (Air Pollution Inspections for Industry/Transportation); Gruppe II 3—Emissionsbegrenzung (Emission Levels); Gruppe II 4—Überwachung der Luftreinhaltung (Monitoring/Testing Procedures); Gruppe II 5—Messtechnik und -verfahren (Measurement/Testing Procedures); Gruppe II 6—Emissions- und Immissionsbegrenzung (Emission and Ambient Levels); Gruppe II 7—Überwachung und Messtechnik (Monitoring/Measurement); Gruppe II 8—Immissionsbegrenzung Bevölkerung/Luft (Ambient Levels for People/Air Pollution); Gruppe II 9—Immissionsbegrenzung Tier/Pflanzen/Sachgüter/Luft (Ambient Levels for Animals, Plants, and Goods/Air Pollution); and Gruppe II 10—Wirkungen Lärm und Erschütterungen (Effects of Noise and Vibration).

634. The noise group deals with both technical and legal matters.

635. Telephone conversation with Dr. Scholz, BMI (Feb. 22, 1980).

636. *Id.*

637. 4 COMM. MKT. REP. (CCH) ¶ 31,067, at 31,416 (Nov. 14, 1978).

cases where the damage to the environment is serious, including the Federal Ambient Levels Protection Law, to a separate, comprehensive section 326 of the Penal Code.<sup>638</sup>

This draft section 326 of the Penal Code provides for criminal charges to be filed where an individual disposes of an unlawful "substance" in a manner that could affect man's health or is potentially hazardous to other living things.<sup>639</sup> These substances include noise. Draft section 326 of the Penal Code probably does not cover motor vehicles but does cover the operation of a plant or machine.<sup>640</sup>

The federal government has spent considerable sums of money on noise-related programs. Some of these programs involve noise abatement measures. Such measures along newly designed federal highways are estimated to have cost DM 150 million in 1978.<sup>641</sup> Approximately DM 50 million was spent in 1978 on noise abatement measures along existing federal highways.<sup>642</sup> In addition, programs like the joint federal/state/local program in Munich to install noiseproof windows<sup>643</sup> are estimated to have cost DM 10 million in 1978.<sup>644</sup> Other programs involve research and development. Table V-10<sup>645</sup> shows the amounts spent on research and development by four ministries in 1978: BMI; BMV; the Ministry for Zoning, Construction and Urban Planning (BMBau); and the Ministry for Research and Technology (BMFT).

---

638. Entwurf eines Sechzehnten Strafrechtsänderungsgesetzes—Gesetz zur Bekämpfung der Umweltkriminalität (Draft Law to Control Environmental Offenses), Drucksache 399/78 (Sept. 9, 1978). For a brief discussion, see 4 COMM. MKT. REP. (CCH) ¶ 31,067, at 31,416 (Nov. 14, 1978).

639. 4 COMM. MKT. REP. (CCH) ¶ 31,067, at 31,416 (1978). Draft § 326 of the Penal Code adopts the approach laid down in § 16 of the Abfallbeseitigungsgesetz (Waste Disposal Law).

640. *Id.*

641. Telephone conversation with Dr. Scholz, BMI (Feb. 22, 1980).

642. *Id.*

643. See Section VII, notes 129-48 and accompanying text *infra*.

644. Telephone conversation with Dr. Scholz, BMI (Feb. 22, 1980).

645. Table V-10 is based on a table in BUNDESMINISTERIUM DES INNERN, UMWELTFORSCHUNGSBERICHT DER BUNDESREGIERUNG 22 (1980).

TABLE V-10

Ministry	Number of Projects	Amount Spent (millions of DM)
BMI	35	7.20
BMV	7	1.00
BMBau	4	0.25
BMFT	20	4.20
TOTALS	66	12.65

The amounts the federal government proposes to spend under the Draft VLärmSchG<sup>646</sup> demonstrate its continuing commitment to reduce traffic noise. In addition, the federal government is a prime mover behind the EEC's environmental action program, which had expenditures in 1977 more than four times greater than 1973 expenditures.<sup>647</sup>

---

646. See notes 580-83 and accompanying text *supra*.

647. See notes 50-52 and accompanying text *supra*.

## SECTION VI

### REGULATION OF TRAFFIC NOISE IN BAVARIA

Traffic is the most serious noise source in Bavaria.<sup>1</sup> One contributing factor has been an increase in the number of motor vehicles. In 1960 there were less than one million motor vehicles in Bavaria. This figure exceeded two million by 1970 and is projected to climb to nearly four million by 1985.<sup>2</sup>

Along with the increase in the number of motor vehicles, the volume of traffic in Bavaria has increased by 650% during the last twenty years.<sup>3</sup> Graph VI-1<sup>4</sup> illustrates the relationship between traffic density and ambient noise levels.

GRAPH VI-1

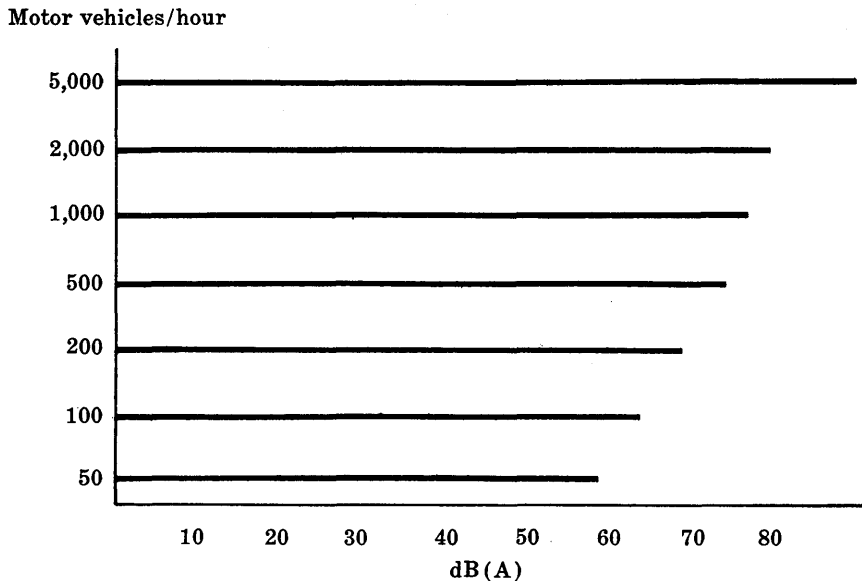

1. KERSTEN, LÄRMSCHUTZ AN HAUPTVERKEHRSSTRASSEN IN DER BAULEIT- UND STRASSENPLANUNG (NOISE CONTROL ON MAJOR HIGHWAYS IN THE PLANNING PROCESS) 1 (1973) [hereinafter cited as KERSTEN REPORT].

2. BAYERISCHES STAATSMINISTERIUM FÜR LANDESENTWICKLUNG UND UMWELTFRAGEN, UMWELTBERICHT (Environmental Report) 29 (1972) [hereinafter cited as BAVARIAN ENVIRONMENTAL REPORT]. Not only is the number of motor vehicles increasing in absolute terms, it is also increasing relative to population. In 1960 there were less than 100 motor vehicles per 1000 residents. This figure increased to more than 200 by 1970 and is projected to climb to more than 300 by 1985. *Id.*

3. *Id.* at 28.

4. Graph VI-1 is based on a graph in the BAVARIAN ENVIRONMENTAL REPORT, *supra* note 2, at 28.



Another factor contributing to the seriousness of Bavaria's traffic noise problem is the absence of posted speed limits on certain new and improved highways, resulting in increased traffic speeds. Graph VI-2<sup>5</sup> illustrates the relationship between speed and ambient noise levels.

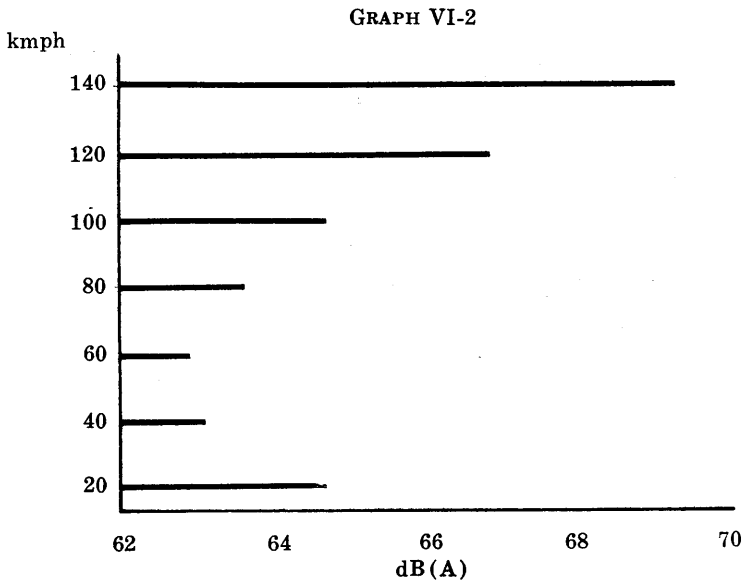

As public concern about noise in general and traffic noise in particular increased, administrative remedies<sup>6</sup> replaced the traditional tort<sup>7</sup> and penal<sup>8</sup> remedies as the principal means of coping with noise problems. Bavaria was one of the first states in the Federal Republic of Germany to enact administrative provisions to supplement the existing tort and penal provisions.

Article 18ff of the Bavarian Penal Law<sup>9</sup> "created a general

5. Graph VI-2 is based on a graph in the BAVARIAN ENVIRONMENTAL REPORT, *supra* note 2, at 29.

6. Administrative remedies are found in "special" laws. Special laws are of two types: noise emission standards and ambient noise level standards.

7. For a discussion of the traditional tort remedies, see Section V, notes 13-16, 26-29 and accompanying text *supra*.

8. For a discussion of the traditional penal remedies, see Section V, notes 17-29 and accompanying text *supra*.

9. Gesetz über das Landesstrafrecht und das Verordnungsrecht auf dem Gebiet der öffentlichen Sicherheit und Ordnung, (Bavarian Penal Law), Nov. 7, 1974, [1974] Gesetz- und Verordnungsblatt [GVBl] 753, reprinted in 3 E. GOSSRAU, H. STEPHANY, W. CONRAD & W. DÜRRE, HANDBUCH DES LÄRMSCHUTZES UND DER LUFTREINHALTUNG (Handbook of Noise Control and Clean Air Maintenance) ¶ 38,155 (1969-1979) [hereinafter cited as NOISE HANDBOOK].

For a discussion of Article 18ff of the Bavarian Penal Law, see Wiethaup, *Zum Bayerischen Immissionsschutzrecht*, 69 DEUTSCHES VERWALTUNGSBLATT 583 (1969).

basis in administrative law to protect against ambient pollution and thereby created the means to control and abate noise."<sup>10</sup> Bavaria now has a number of laws, ordinances, regulations, guidelines, and resolutions in force that are designed to control and abate noise.

#### A. Important Resolutions and Related Matters

On September 20, 1963, the Bavarian Ministry of the Interior<sup>11</sup> and the Bavarian Ministry for Commerce and Transportation<sup>12</sup> passed a resolution entitled "Controlling Noise" (1963 Resolution).<sup>13</sup> According to the 1963 Resolution: "It is the task of general administrative personnel, the police and, in some cases, municipal officials to control unnecessary and unreasonable noise. This task requires ordinances and regulations which prevent, interrupt, and punish, either with imprisonment or fine, activities which are noisy."<sup>14</sup>

The 1963 Resolution is divided into three parts. Part I, entitled "The Legal Basis,"<sup>15</sup> outlines existing laws, ordinances, and regulations under eight different headings: (1) general provisions, (2) onstreet motor vehicles, (3) offstreet motor vehicles, (4) aircraft, (5) ships, (6) industry, (7) entertainment, and (8) other provisions.<sup>16</sup> Except for offstreet motor vehicle noise,<sup>17</sup> motor vehicle noise is discussed solely in terms of federal laws, ordinances, and regulations.<sup>18</sup>

"Since noise frequently results from technology and is measured, controlled and abated through the application of technology,"<sup>19</sup> part II of the 1963 Resolution, entitled "Technical Guide-

10. KERSTEN REPORT, *supra* note 1, at 1.

11. Bayerisches Staatministerium des Innern.

12. Bayerisches Staatministerium für Wirtschaft und Verkehr.

13. Gemeinsame Entschliessung der Bayerischen Staatsministerien des Innern und für Wirtschaft und Verkehr, Bekämpfung des Lärms (Controlling Noise) (Sept. 20, 1963) [hereinafter cited as 1963 Resolution], reprinted in 3 NOISE HANDBOOK, *supra* note 9, ¶ 38,165.

14. *Id.* at 1.

15. Rechtsgrundlagen.

16. 1963 Resolution, *supra* note 13, at 1-7.

17. The discussion of offstreet motor vehicle noise mentions § 24 of the Bavarian Garage Regulations, which is discussed at notes 103-04 and accompanying text *infra*.

18. Part I of the 1963 Resolution mentions two federal ordinances in connection with its discussion of motor vehicle noise: §§ 1, 4, 12, 19, and 48 of the Motor Vehicle Ordinance (StVO); and §§ 30, 35, 49, and 55 of the Motor Vehicle Approval Ordinance (StVZO). For a discussion of the StVO and the StVZO, see Section V, notes 82-184, 223-72, 287-91, 298-310, 335-47 and accompanying text *supra*.

19. 1963 Resolution, *supra* note 13, at 7.

lines,"<sup>20</sup> incorporates, by reference, technical appendices attached to the 1963 Resolution. One appendix, entitled "General Technical Guidelines for Judging Noise Protection" (General Guidelines),<sup>21</sup> defines noise as "a sound which threatens well-being or health"<sup>22</sup> and outlines noise measurement techniques as they existed in 1963. At that time the Federal Republic of Germany, unlike the United States, England, and France, used a DIN-phon system<sup>23</sup> rather than a dB(A) system to measure noise.<sup>24</sup>

The General Guidelines also review what was then known about the effects of noise. Table VI-1<sup>25</sup> summarizes these effects under five categories of noise.

---

20. Technische Richtlinien.

21. Allgemeine technische Richtlinien zur Beurteilung des Abwehr von Lärm. 1963 Resolution, *supra* note 13, at 9.

22. *Id.* According to the General Guidelines, noise is not susceptible to a precise definition because of the subjective factor inherent in any determination of what is and is not noise. Two people, for example, may react differently to the same sound. Alternatively, one person may react differently to the same sound, depending on the time, place, and volume of the sound.

23. The General Guidelines contain the following DIN-phon scale:

DIN-phon	Activity
0	Beginning of the hearing spectrum
10-30	Sound of leaves; whispering
30-60	Normal conversation
60-80	Interior motor vehicle noise
70-90	Exterior motor vehicle noise
80-100	Noise in a working area
100-120	Sledgehammer; piledriver; an accelerating motor vehicle without a muffler
110-130	Propellar aircraft
120-140	Cannon
140-more	Jet aircraft

*Id.* at 10.

24. The DIN-phon system is equivalent to the dB(A) system. See DER RAT VON SACHVERSTÄNDIGEN FÜR UMWELTFRAGEN, UMWELTGUTACHTEN 1974 (Environmental Assessments 1974), at 193 n.1 (1974). Thus, an increase of 10 DIN-phon is equivalent to a doubling of the volume. 1963 Resolution, *supra* note 13, at 10.

25. Table VI-1 is based on information found in the General Guidelines. 1963 Resolution, *supra* note 13, at 10.

TABLE VI-1

Category of Noise	Effects
Under 30 DIN-phon	No effects <sup>26</sup>
30-65 DIN-phon	Physiological and secondary vegetative effects <sup>27</sup>
65-90 DIN-phon	Primary vegetative effects <sup>28</sup>
90-120 DIN-phon	Damage to the inner ear <sup>29</sup>
Over 120 DIN-phon	Danger to life <sup>30</sup>

The General Guidelines recommend the noise emission standards found in the 1960 version of VDI 2058.<sup>31</sup>

According to the General Guidelines, noise emanating from

26. It is inaccurate to speak of noise at these minimal levels. *Id.*

27. Physiological reactions because of noise are relatively unimportant if they occur infrequently and their duration is brief. If levels of 30-65 DIN-phon occur at times when a person is seeking rest, they can cause secondary vegetative reactions such as an upset stomach or heart trouble. *Id.* at 11.

28. Levels of 65-90 DIN-phon cause the blood vessels to constrict. Such primary vegetative reactions are unavoidable and in most cases are of no significance to health and well-being. However, continued constriction of the blood vessels is one indication of tension. *Id.*

29. Levels of 90-120 DIN-phon cause temporary threshold shift. If continued, deafness will result. *Id.*

30. Levels in excess of 120 DIN-phon pose a threat to nerve cells. Paralysis or death can result. *Id.*

31. For a discussion of VDI (the Society of German Engineers) and the guidelines it developed, particularly VDI 2058, see Section V, notes 510-27 and accompanying text *supra*.

The 1960 version of VDI 2058 recommended acceptable noise levels for various areas. The tables below show the acceptable noise levels for work areas and areas adjoining work areas.

Table A

Activity	DIN-phon
Work requiring continuing and intensive thought	50
Office work	70
Other work	90

a machine "is generally a sign of technical imperfection."<sup>32</sup> Since noise control is frequently expensive, the guidelines suggest that an optimal solution, both in terms of acoustics and economics, must be sought.<sup>33</sup> Noise control measures should be designed to prevent or minimize noise at its source and control noise transmission.<sup>34</sup>

The other appendix is entitled "Rules and Technical Guidelines in Controlling Transportation Noise" (Transportation Noise Guidelines).<sup>35</sup> Three different sources receive attention: traffic noise, ship noise, and aircraft noise.<sup>36</sup> Traffic noise is discussed in terms of the January 1, 1959, version of the German Noise Emission Guidelines.<sup>37</sup>

Part III of the 1963 Resolution lists sources of expert opinion. These sources included the Bavarian Business Institute,<sup>38</sup> the Bavarian Institute for Work Safety,<sup>39</sup> and the Technical Control Association (TÜV) for Bavaria.<sup>40</sup>

During the nine-year period following the adoption of the 1963 Resolution, traffic noise and noise in general received insignificant attention. This changed dramatically in 1972. Bavaria is a member of the Committee of State Governments for Ambient

Table B

Area	DIN-phon	
	Day	Night
Industrial areas	65	50
Mainly residential areas	60	40
Exclusively residential areas	50	35

1963 Resolution, *supra* note 13, at 12. "Night" was defined by the 1960 version of VDI 2058 as the period between 10:00 p.m. and 7:00 a.m. *Id.*

32. 1963 Resolution, *supra* note 13, at 13.

33. *Id.*

34. *Id.*

35. Vorschriften und technische Richtlinien zur Lärmbekämpfung im Verkehr. *Id.* at 16.

36. *Id.*

37. *Id.* For a discussion of the German Noise Emission Guidelines, see Section V, notes 352, 366 and accompanying text *supra*.

38. Bayerische Landesgewerbeanstalt Nürnberg.

39. Bayerisches Landesinstitut für Arbeitsschutz.

40. Technischer Überwachungs-Verein Bayern (TÜV).

Noise Level Control.<sup>41</sup> In March 1972 the committee met, examined the traffic noise problem, adopted a series of proposals, and passed a resolution entitled "The Problems of Controlling Traffic Noise" (1972 Resolution).<sup>42</sup>

According to the 1972 Resolution, traffic noise in German cities increased an average of 800% between 1900 and 1970.<sup>43</sup> Traffic noise levels of more than 75 dB(A) were common on heavily traveled urban highways.<sup>44</sup> As a result, the 1972 Resolution concludes that the populace views motor vehicles as the most serious noise sources.<sup>45</sup>

The 1972 Resolution contains a series of proposals aimed at controlling the growing problem of traffic noise.<sup>46</sup> These proposals are divided into four groups: "Noise Reduction at the Source (Active Noise Protection Measures),"<sup>47</sup> "Planning Measures,"<sup>48</sup> "Passive Noise Protection Measures,"<sup>49</sup> and "General Measures."<sup>50</sup> Each of these four groups is further subdivided into some combination of legal, administrative, research and development, or "other" measures.

There was general agreement among the state officials who drafted the 1972 Resolution that active noise protection measures should receive the highest priority in any noise control program.<sup>51</sup> Consequently, a full range of active noise protection measures—legal, administrative, enforcement, research and development, and "other"—were proposed. These proposals involve the motor vehicle itself, the interaction between the motor vehicle and the highway on which it operates, and the traffic regulations governing operation of motor vehicles.

Some proposals are aimed at reducing noise caused by the motor vehicle itself. Legal measures include reducing noise emis-

41. Länderausschuss für Immissionsschutz.

42. Entschliessung des Länderausschusses für Immissionsschutz zu Problemen der Bekämpfung des Strassenverkehrslärms (The Problems of Controlling Traffic Noise) (Mar. 1972) [hereinafter cited as 1972 Resolution].

43. *Id.*

44. *Id.*

45. *Id.*

46. *Id.* Bavarians agree with the rest of the populace of the Federal Republic of Germany that motor vehicles are the most serious noise source. See note 1 *supra*.

47. Lärminderung an der Entstehungsstelle (aktive Lärmschutzmassnahmen).

48. Plänerische Massnahmen.

49. Passive Lärmschutzmassnahmen.

50. Allgemeine Massnahmen.

51. The same conclusion has been reached elsewhere. See Section I, note 90 and accompanying text *supra*.

sion standards for motor vehicles,<sup>52</sup> continuing the limitation on the use of tires with spikes,<sup>53</sup> changing the method of taxing motor vehicles,<sup>54</sup> and providing tax incentives to the manufacturers of mass transit.<sup>55</sup> Administrative measures include issuing administrative regulations for section 49 of the Motor Vehicle Approval Ordinance (StVO)<sup>56</sup> and encouraging nonindustry sources to minimize motor vehicle noise.<sup>57</sup> Enforcement measures include improving traffic control by the police<sup>58</sup> and increasing the amount of testing conducted by TÜV's.<sup>59</sup> Research and development measures include encouraging improvements in the construction of motor vehicles,<sup>60</sup> promoting research on and development of

---

52. This measure would require action at both the national and international levels. At the national level, the most important recommended action is the enactment of the Federal Ambient Levels Protection Law, which was enacted on Mar. 14, 1974. For a discussion of the Federal Ambient Levels Protection Law, see Section V, notes 584-618 and accompanying text *supra*.

At the international level, one recommended action is for the European Economic Community (EEC) to redelegate to member states the authority to establish noise emission standards. The EEC had relied on this authority in issuing its Directive "on the approximation of the laws of the Member States relating to the permissible sound level and the exhaust system of motor vehicles" (EEC Noise Emission Directive). For a discussion of the EEC Noise Emission Directive, see Section V, notes 367-413, 423-43 and accompanying text *supra*. Another recommended action is that future EEC directives, adopted pursuant to art. 100 of the Treaty of Rome, be viewed as establishing minimal standards. Under this approach, member states could enact more stringent standards at their discretion. 1972 Resolution, *supra* note 42, § I.1.1.3.-4.

53. Tires with spikes can only be used during the four winter months. 1972 Resolution, *supra* note 42, § I.1.1.2.

54. The 1972 Resolution recommends that motor vehicles be taxed on a basis other than displacement. *Id.* § I.1.1.3.1. No alternative basis is suggested. The 1972 Resolution does indicate that the basis should be one that induces the automobile industry to produce motor vehicles with quieter engines and mufflers. *Id.*

55. The 1972 Resolution recommends tax incentives to spur the production and use of buses and electric motor vehicles. *Id.* § I.1.1.3.2.

56. One goal of § 49 regulations should be to improve motor vehicle construction, *e.g.*, minimizing intake and exhaust noise, and minimizing ignition as well as mechanical noise. *Id.* § I.1.2.1.1.

Another goal should be to establish noise emission standards for noise that occurs when motor vehicles are operated, *e.g.*, idling, acceleration, and cruising noise. These standards should be evaluated periodically and adjusted downward whenever available technology permits. *Id.* § I.1.2.1.2.

57. One nonindustry source is the Society of German Engineers (VDI) and its Commission on Noise Reduction. *Id.* § I.1.2.2.

58. The 1972 Resolution concludes that the police would be more effective in controlling noise if they were (1) instructed on the importance of noise control and (2) equipped with noise measurement devices. *Id.* § I.1.3.1.

59. TÜV's currently test motor vehicles every other year. The 1972 Resolution proposes voluntary testing on a more frequent basis. *Id.* § I.1.3.2.

60. Three improvements in the construction of motor vehicles are listed: (1) encasing

quieter tires and body parts,<sup>61</sup> and developing simpler and less expensive measurement methods.<sup>62</sup> "Other" measures include educating motorists as to their environmental responsibilities, encouraging the purchase of quiet motor vehicles by government entities, and linking the award of major government contracts to the development of quieter motor vehicles.<sup>63</sup>

Other proposals mentioned in the 1972 Resolution deal with noise caused by the interaction between the motor vehicle and the highway on which it operates. Administrative measures include using surfaces that reduce traffic and tire noise,<sup>64</sup> using noise absorbent walls and screens,<sup>65</sup> using vegetation that is sufficiently deep and thick along highways,<sup>66</sup> and using tunnels and depressed highways.<sup>67</sup> Enforcement measures include examining plans in accordance with section 9(a)(3) of the Federal Highway Law (FStrG) and applicable state provisions and collecting contributions for noise protection measures in accordance with section 17(4) of the FStrG and applicable state provisions.<sup>68</sup> Investigating alternative street surfaces was the research and development measure proposed.<sup>69</sup> Developing an appreciation for noise problems on the part of highway personnel was the "other" measure proposed.<sup>70</sup>

Still other proposals would change traffic regulations in order to reduce noise. Legal measures include improving the flow of traffic<sup>71</sup> and reducing speed limits.<sup>72</sup> Issuing administrative regulations for section 45(1) of the StVO that would either ban or limit

---

the motor of heavily used motor vehicles, (2) developing quieter construction elements and propulsion systems, and (3) developing quieter doors. *Id.* § I.1.4.1.

61. *Id.* § I.1.4.2.

62. *Id.* § I.1.4.3.

63. *Id.* § I.1.5.

64. Cobblestone streets should be replaced by asphalt streets. *Id.* § I.2.2.1.

65. Noise absorbent walls and screens are of particular importance when the highway is elevated. *Id.* § I.2.2.2.

66. *Id.* § I.2.2.3.

67. *Id.* § I.2.2.4.

68. *Id.* § I.2.3. For a discussion of the FStrG, see Section V, notes 549-64 and accompanying text *supra*.

69. 1972 Resolution, *supra* note 42, § I.2.4.

70. The 1972 Resolution recommends that highway personnel receive instruction on noise control, but the nature of this instruction is not specified. *Id.* § I.2.5.

71. One way to improve the flow of traffic is to adjust traffic lights so that motor vehicles do not need to stop. Germans refer to the effect produced by this adjustment as the "grüne Welle" or "green wave" effect. See Section V, notes 583-84 and accompanying text *supra*.

72. 1972 Resolution, *supra* note 42, § I.3.1.2. Caution must be exercised in adjusting speed limits. See Section V, notes 578-82 and accompanying text *supra*.



traffic at night in residential areas was the administrative measure proposed.<sup>73</sup> Enforcement measures include enforcing existing regulations more strictly and instructing police on noise control.<sup>74</sup> Developing better methods to control the flow of traffic was the research and development measure proposed.<sup>75</sup> Educating motorists as to their environmental responsibilities was the "other" measure proposed.<sup>76</sup>

In contrast to the full range of active noise protection measures proposed, the range of planning measures, passive noise protection measures, and general measures proposed was much narrower. Planning measures are limited to legal, administrative, and "other" proposals. Enacting the Federal Ambient Levels Protection Law (BImSchG) was the legal measure proposed.<sup>77</sup> Administrative measures are divided into two categories: (1) land planning and (2) guidelines.<sup>78</sup> The 1972 Resolution encourages land planning on a regional basis and recommends the issuance of guidelines to be used by state highway departments<sup>79</sup> and local governments<sup>80</sup> in judging the adequacy of highway plans. "Other" measures include stabilizing the noise situation in severely impacted areas, and providing planning subsidies.<sup>81</sup>

---

73. 1972 Resolution, *supra* note 42, § I.3.2. For a discussion of § 45 of the StVO, see Section V, notes 149-59 and accompanying text *supra*.

The Minister of Transportation has issued Guidelines Governing Traffic Measures to Protect Sleep. For a discussion of these guidelines, which are based on § 45, see Section V, notes 534-611 and accompanying text *supra*.

74. 1972 Resolution, *supra* note 42, § I.3.3.

75. *Id.* § I.3.4.

76. The 1972 Resolution recommends that motorists be educated to avoid unnecessary honking or idling of their motor vehicles. *Id.* § I.3.5.

77. *Id.* § II.1. Section 42 of the proposed BImSchG received a mixed reaction. The 1972 Resolution approved of § 42(1) because that provision would require planners to minimize pollution effects in residential areas or other areas requiring protection but criticized § 42(2) because it could be interpreted as giving priority to traffic flow over noise considerations.

78. *Id.* § II.2.

79. Highway department guidelines should assure that proper consideration is given to the effects new highways or improvements on existing highways will have on the surrounding neighborhood. *Id.* § II.2.2.1.

80. Local government guidelines should assure that proper consideration is given to the interests of the public vis-à-vis highway requirements. Three different guidelines were suggested:

- (1) Guidelines concerning the effects of traffic noise on residential areas;
- (2) Guidelines concerning reasonable ambient noise levels and minimum distances between highways and residential areas; and
- (3) Guidelines concerning measures to protect against noise in urban construction.

*Id.* § II.2.2.

81. *Id.* § II.5.

Passive noise protection measures are limited to legal, administrative, and enforcement proposals. Legal measures include amending state building ordinances to protect residential areas<sup>82</sup> and increasing the depreciation allowances under section 82(e) of the Regulations to Implement the Income Tax for products that reduce, minimize, or abate noise or vibration.<sup>83</sup> Administrative measures include installing doors, windows, attics, outer walls, and roofs that resist noise transmission<sup>84</sup> and using noise absorbent materials.<sup>85</sup> Requiring observance of the regulations implementing state building ordinances was the enforcement measure proposed.<sup>86</sup>

Five general measures were proposed: (1) improving mass transit at the expense of individual transit, (2) investigating and developing quieter transportation systems, (3) simplifying and improving noise measurement procedures, (4) developing new technology, and (5) comparing annoyance costs with the costs of protective measures.<sup>87</sup>

The Bavarian Ministry for Land Development and the Environment<sup>88</sup> also published the *Bavarian Environmental Report* in 1972.<sup>89</sup> The *Bavarian Environmental Report* mentioned the 1972 Resolution and recommended the adoption of its proposals.<sup>90</sup>

The *Bavarian Environmental Report* was divided into five sections.<sup>91</sup> A portion of section 2, entitled "Environmental Protection,"<sup>92</sup> was devoted to noise. After describing the problems posed by noise,<sup>93</sup> goals and measures to achieve those goals were dis-

82. *Id.* § III.1.1. Particular attention should be given to the location of parking places and garages. *Id.*

83. *Id.* § III.1.2.

84. *Id.* § III.2.1. For a discussion of the Munich program to install noiseproof windows, see Section VII, notes 142-81 and accompanying text *infra*.

85. 1972 Resolution, *supra* note 42, § III.2.2.

86. *Id.* § III.3.

87. *Id.* § IV.1-5.

88. Bayerisches Staatsministerium für Landesentwicklung und Umweltfragen.

89. Note 2 *supra*.

90. BAVARIAN ENVIRONMENTAL REPORT, *supra* note 2, at 29, 31.

91. In addition to § 2, Environmental Protection, the remaining four sections of the *Bavarian Environmental Report* dealt with the following topics: § 1—Allgemeines (General), § 3—Umweltgestaltung und Umweltvermittlung (State of the Environment), § 4—Gewässergüte und Wasserwirtschaftliche Rahmenplanung (Water and Water Planning), § 5—Anhang (Appendix).

92. Umweltschutz.

93. Some of the highlights to the *Bavarian Environmental Report's* description of the problems posed by noise have already been mentioned. See notes 2-5 and accompanying text *supra*.

cussed.<sup>94</sup> One goal was to limit the growth of annoying noise.<sup>95</sup> Another goal was to reduce ambient noise levels, particularly in residential areas, through technical, planning, legal, and administrative measures.<sup>96</sup> To achieve the goal of noise reduction, primary measures—measures that reduce noise at the source—were favored over secondary measures.<sup>97</sup>

Four types of noise—aircraft noise, traffic noise, business noise, and leisure noise—were discussed in the *Bavarian Environmental Report*.<sup>98</sup> Its discussion of traffic noise mentioned an effort to prepare noise maps for areas that are subjected to particularly serious noise.<sup>99</sup> These noise maps were designed to be used by planners, contractors, architects, doctors, and sociologists. The *Bavarian Environmental Report* emphasized that the preparation of noise maps would not necessarily require that measurements be taken in every case. For example, data on traffic noise could be derived from information about traffic density.<sup>100</sup>

### B. Laws and Related Matters

A successful noise control program from the Bavarian perspective involves four interrelated and coordinated efforts:

It should be stressed that the motor vehicle industry is expected to develop quieter motors and less noisy motor vehicles. In addition, the actions of drivers must be controlled by traffic measures. A more significant effort to protect people from the harmful effects of noise can be made by more well thought out building plans and more stringent construction requirements. Finally, those who are responsible for the construction of streets and highways are expected to use all available measures to control and/or abate noise.<sup>101</sup>

Bavaria's noise control program will be analyzed in terms of its efforts in these four areas.

---

94. BAVARIAN ENVIRONMENTAL REPORT, *supra* note 2, at 28.

95. *Id.*

96. *Id.*

97. *Id.* This approach should be compared with the approach adopted by the Committee of State Governments to Protect Ambient Environmental Levels. See note 51 and accompanying text *supra*. The *Bavarian Environmental Report* acknowledged that the amount available for noise reduction in 1972, DM 1.5 million was inadequate and that this figure would have to be increased in succeeding years. BAVARIAN ENVIRONMENTAL REPORT, *supra* note 2, at 28.

98. See BAVARIAN ENVIRONMENTAL REPORT, *supra* note 2, at 28-31.

99. *Id.* at 31.

100. *Id.*

101. KERSTEN REPORT, *supra* note 1, at 1.

### 1. *Source measures*

Because of the pervasiveness of federal regulation of traffic noise, Bavaria has no laws, ordinances, regulations, or guidelines to control noise at the source.<sup>102</sup> The Committee of State Governments, however, provides the states a means of exercising collective power. Resolutions like the 1972 Resolution put the federal government and manufacturers on notice that states deem a particular situation serious enough to require appropriate attention.

### 2. *Operational measures*

The Bavarian Garage Regulations<sup>103</sup> are the only operational measure that has been enacted. Section 24 prohibits "honking, noisy idling, and other noise in and near garages, parking places, entrances, and exits when such noise unreasonably disturbs the neighborhood."<sup>104</sup> The 1972 Resolution outlines additional operational measures that have not been enacted. These include adjusting traffic lights so that motor vehicles need not stop, adjusting speed limits, and educating motorists to avoid unnecessary honking and idling.

### 3. *Building measures*

Federal building measures include the Zoning Law (ROG),<sup>105</sup> the Federal Building Law (BBauG),<sup>106</sup> and the Building Use Regulations (BauNVO).<sup>107</sup> In May 1971 the German Norm Commission<sup>108</sup> adopted DIN 18005,<sup>109</sup> borrowing the BauNVO's land-use categories<sup>110</sup> and assigning a recommended ambient noise level to

102. Federal regulation is pervasive because the federal government has established not only noise emission standards but also ambient noise level standards. As a result, Bavaria and the other states in the Federal Republic of Germany have relatively few noise abatement options available to them.

103. Landesverordnung des Bayerischen Staatsministeriums des Innern über Garagen (Garagenverordnung) (Bavarian Garage Regulations), Apr. 13, 1966, [1966] GVBl 162 [hereinafter cited as Bavarian Garage Regulations]. Selected excerpts are reprinted in 1 NOISE HANDBOOK, *supra* note 9, ¶ 21,160.

104. *Id.* § 24.

105. See Section V, note 534 and accompanying text *supra*. For a discussion of the ROG, see Section V, notes 537-41 and accompanying text *supra*.

106. See Section V, note 533 and accompanying text *supra*. For a discussion of the BBauG, see Section V, notes 542-45 and accompanying text *supra*.

107. See Section V, note 536 and accompanying text *supra*. For a discussion of the BauNVO, see Section V, notes 546-48 and accompanying text *supra*.

108. See Section V, note 528 and accompanying text *supra*.

109. See Section V, note 529 and accompanying text *supra*. For a discussion of DIN 18005, see Section V, notes 529-31 and accompanying text *supra*.

110. See Section V, notes 546-48 and accompanying text *supra*.

each category.<sup>111</sup>

On May 19, 1972, the Bavarian Ministry of the Interior published an announcement entitled "Considering Noise Control in Urban Construction" (Urban Construction Announcement).<sup>112</sup> The Urban Construction Announcement analyzes the relationship between the BBauG, the BauNVO, and DIN 18005 and "recommends the use of DIN 18005 in the zoning process."<sup>113</sup>

Section 1(4) of the BBauG requires consideration of social and cultural needs as well as safety and health needs in the zoning process. This requirement dictates that noise be kept as far away from noise-sensitive areas, particularly residential areas or areas that serve a similarly useful purpose, as possible.<sup>114</sup> DIN 18005 contains instructions that assist zoning authorities in achieving this goal. The Urban Construction Announcement, however, emphasizes that noise is but one of several factors that zoning authorities must weigh. Thus, the task of the zoning authorities is to determine "if and to what extent the noise factor should be given priority over other factors."<sup>115</sup>

The BauNVO divides real estate into various categories and specifies what activities are permissible within each category. The intent of the BauNVO is to protect individuals from disturbances originating within a given area. If the source of the disturbance comes from an adjoining area, the provisions of the BauNVO are inapplicable.<sup>116</sup>

The Urban Construction Announcement lists three possible ways of dealing with disturbances that originate in adjoining areas: "(1) sufficient distance between areas which differ significantly in noise level; (2) regulation of intermediate areas; and (3) noise screens."<sup>117</sup> As a general rule, the difference in ambient noise levels between adjoining areas should not exceed 5 dB(A).<sup>118</sup>

DIN 18005 only provides instructions to assist zoning author-

111. See Table V-8 *supra*.

112. Bekanntmachung des Bayerischen Staatsministeriums des Innern, Berücksichtigung des Schallschutzes im Städtebau (Considering Noise Control in Urban Construction) (1972) [hereinafter cited as Urban Construction Announcement], reprinted in 1 NOISE HANDBOOK, *supra* note 9, ¶ 18,167.

113. *Id.* at 2.

114. *Id.*

115. *Id.*

116. *Id.*

117. *Id.*

118. *Id.* The BauNVO permits distinctions within business and industrial areas. Consequently, distinctions based on noise intensity are permissible. Urban Construction Announcement, *supra* note 112, at 2.

ities. Consequently, it cannot be used to determine whether a particular activity is permissible. Section 5 of DIN 18005 sets forth ambient noise levels for various land-use categories. Rural and inner-city land-use categories are differentiated on the basis of permissible use. Business and industry land-use categories are differentiated on the basis of the type of activity and the nature and requirements of the activity. Any local zoning authority that either ignores the recommended ambient noise levels or deviates from them must justify this action in an explanatory report accompanying its master plan<sup>119</sup> and also in a report approving the proposed building plans.<sup>120</sup>

The Bavarian Planning Law (BayLplG)<sup>121</sup> is a zoning law. Article 1 of the BayLplG announces that "[p]lanning is the responsibility of the state."<sup>122</sup> The components of a state's planning program are found in article 4. They include a State Development Program, technical programs and plans, and regional plans. In discharging its planning responsibility, the state performs two functions. One function is to prepare comprehensive technical programs and plans, to constantly monitor such programs and plans, and to adjust them in light of subsequent developments.<sup>123</sup> The other function is to make planning entities<sup>124</sup> within the state aware of zoning requirements.<sup>125</sup>

As well as requiring compliance with the general principles articulated in section 2 of the ROG,<sup>126</sup> article 2 of the BayLplG lists fifteen additional general principles to guide planners in Bavaria.<sup>127</sup> Installations<sup>128</sup> emitting noise, for example, are to be located so as to minimize any dangers, disadvantages, or disturbances associated with their use.<sup>129</sup>

Bavaria also has its own Building Ordinance (BayBO).<sup>130</sup> The

119. For a discussion of master plans in the context of the BBauG, see Section V, notes 542-45 and accompanying text *supra*.

120. Urban Construction Announcement, *supra* note 112, at 3.

121. Bayerisches Landesplanungsgesetz (Bavarian Planning Law), Feb. 6, 1970, [1970] GVBl 9, as amended by Law of Feb. 19, 1971, [1971] GVBl 65 [hereinafter cited as BayLplG], reprinted in 1 NOISE HANDBOOK, *supra* note 9, ¶ 17,155.

122. *Id.* art. 1(2).

123. *Id.* art. 1(1)(1).

124. Planning entities include not only federal and state governmental planning entities but also corporations, institutes, and foundations. *Id.* art. 1(1)(2).

125. *Id.*

126. See Section V, notes 538-39 and accompanying text *supra*.

127. BayLplG, *supra* note 121, art. 2.

128. In German law the term "installations" normally does not include motor vehicles, but there are exceptions. See, e.g., Section V, note 588 and accompanying text.

129. BayLplG, *supra* note 121, art. 2(11).

130. Bayerische Bauordnung (Bavarian Building Ordinance) Aug. 21, 1969, [1969]

general philosophy of the BayBO is exemplified in article 3: "Building projects are to be planned, constructed, altered and maintained so that public safety and order, particularly life or health, will not be endangered."<sup>131</sup> The particular problems of noise and vibration are dealt with in article 17, which states that noise is a factor to be considered whenever a building is constructed, altered, or its use changed.<sup>132</sup>

Article 33 requires ceilings and floors of dwelling places, entertainment rooms, or rooms adjoining entertainment rooms to be noiseproofed.<sup>133</sup> The following are excepted from noiseproofing: (1) ceilings and floors between rooms in the same house, (2) floors of unused attics, and (3) ceilings or floors of workrooms that do not adjoin living or working areas of another party.<sup>134</sup>

Article 62 deals with garages and parking places. It provides *inter alia* that "[p]arking places and garages are to be planned and constructed so that the noise produced by their use will neither endanger health nor unreasonably disturb work, existence, and rest in that area."<sup>135</sup> Garages, rather than parking places, can be required if parking endangers health or disturbs work, existence, or rest.<sup>136</sup>

Article 72 addresses the question of responsibility: "If a building project is constructed, altered, or destroyed, the person in charge of the project and those who assist him are responsible for compliance with the regulations and the requirements established by governmental authorities."<sup>137</sup>

#### 4. Highway measures

On March 13, 1973, the Bavarian Ministry of the Interior published an announcement entitled "Considering Noise Control on Major Thoroughfares in Zoning and Highway Planning" (Highway Planning Announcement).<sup>138</sup> The Highway Planning

---

GVBl 263 [hereinafter cited as BayBO]. Selected excerpts are reprinted in 1 NOISE HANDBOOK, *supra* note 9, ¶ 21,155.

131. *Id.* art. 3(1).

132. *Id.* art. 17(1).

133. *Id.* art. 33(8).

134. *Id.* art. 33(9).

135. *Id.* art. 62(8).

136. *Id.* art. 62(4).

137. *Id.* art. 72.

138. Bekanntmachung des Bayerischen Staatsministeriums des Innern, Berücksichtigung des Lärmschutzes an Hauptverkehrsstrassen in der Bauleit- und Strassenplanung (Considering Noise Control on Major Thoroughfares in Zoning and Highway Planning) (1973) [hereinafter cited as Highway Planning Announcement], *reprinted in*

Announcement outlines how Bavaria proposed to integrate the BBauG,<sup>139</sup> the BayBO,<sup>140</sup> the Federal Highway Law,<sup>141</sup> and the Bavarian Highway and Street Law<sup>142</sup> into one comprehensive program.

The Highway Planning Announcement notes the increase in traffic noise and the concomitant growth of public concern about the environmental noise problem.<sup>143</sup> Efforts have been made to minimize traffic noise by controlling noise sources and by educating drivers.<sup>144</sup> In the future, attention will be given to urban and highway planning.<sup>145</sup> Such planning requires a close working relationship between urban and highway planners. As the Highway Planning Announcement states: "Here is where 'interrelated planning' must be guaranteed."<sup>146</sup>

The Highway Planning Announcement consists of three parts and an appendix.<sup>147</sup> Part A is entitled "Noise Protection in Zoning"<sup>148</sup> and establishes the following goal: "New areas of con-

1 NOISE HANDBOOK, *supra* note 9, ¶ 18,168.

The purpose of the Highway Planning Announcement is "to minimize future planning mistakes." Annex to Letter from Oberste Baubehörde (Bavarian Building Department) to several governmental agencies entitled "Vorläufige ergänzende Hinweise" (Preliminary, Supplemental Instructions) 1 (Aug. 17, 1973) [hereinafter cited as Preliminary Instructions].

139. See Section V, note 533 and accompanying text *supra*.

140. See note 130 *supra*.

141. See Section V, note 535 and accompanying text *supra*. For a discussion of the FStrG, see Section V, notes 675-96 and accompanying text *supra*.

142. Bayerisches Strassen- und Wegegesetz (Bavarian Highway and Street Law), Jul. 2, 1974, [1974] GVBl 333 [hereinafter cited as Bavarian Highway and Street Law]. Selected excerpts are reprinted in 1 NOISE HANDBOOK, *supra* note 9, ¶ 19,156.

143. Highway Planning Announcement, *supra* note 138, at 1.

144. *Id.*

145. *Id.*

146. *Id.*

147. Noise abatement measures on planned highways are governed by pts. A and C of the Highway Planning Announcement. Part B governs noise abatement measures on existing highways. *Id.* at 2. Noise abatement measures on existing highways frequently involve substantial costs. Such measures, therefore, should only be undertaken if the result will be a "significant improvement" in the noise situation. Preliminary Instructions, *supra* note 138, at 2.

If the highway is a federal highway, the planning concepts of § 16(2) of the FStrG, rather than state and local planning concepts, are controlling. Highway Planning Announcement, *supra* note 138, at 1.

No noise measures can be required if the noise problem is caused by an increase in traffic or by a detour. *Id.*

The appendix of the Highway Planning Announcement contains excerpts from the Federal Highway Institute's "Measures to Protect Against Noise." *Id.* at 6-9.

148. Lärmschutz in der Bauleitplanung. Part A has been described as the "most important and difficult part of the [Highway Planning Announcement]." KERSTEN REPORT, *supra* note 1, at 4. Part A imposes on local governments the duty of implementing



struction adjacent to existing or planned highways, particularly major through highways, are to be planned so as to reduce as far as possible the exposure of residents to unreasonable noise."<sup>149</sup> In achieving this goal, the Highway Planning Announcement recommends the use of three other documents. The first document, Directions for Developing and Implementing Building Plans (Planning Guidelines),<sup>150</sup> published on November 17, 1967, discusses necessary noise protection measures in urban planning, particularly with reference to traffic noise.<sup>151</sup> The second document, Supplemental Directive for Developing and Implementing Building Plans (Supplemental Planning Guidelines),<sup>152</sup> published on September 15, 1969, became necessary since some of the material on which the Planning Guidelines were based had been "changed, supplemented, or reorganized."<sup>153</sup> In addition, Guidelines To Be Used in Considering Traffic in Urban Planning (1968 Guidelines) were published on November 21, 1968, by the Urban Planning Commission.<sup>154</sup> Section IV of the Supplemental Planning Guidelines outlines for zoning authorities urban planning measures to abate the harmful effects of traffic noise.<sup>155</sup> The preferred measure is spatial separation between highways and areas where people work, play, or live.<sup>156</sup> If spatial separation is impossible or impractical, zoning regulations should specify measures, such as placement of the building or protective vegetation, that will minimize harmful noise.<sup>157</sup> The third document is the Urban

---

noise protection measures in urban planning because they are the entities responsible for zoning and building plans approval.

149. Highway Planning Announcement, *supra* note 138, at 1.

150. Entschliessung des Bayerischen Staatministeriums des Innern, Hinweise für die Ausarbeitung und Aufstellung der Bauleitpläne (Directive for Developing and Implementing Building Plans) (Nov. 17, 1967) [hereinafter cited as Planning Guidelines], *reprinted in* 1 NOISE HANDBOOK, *supra* note 9, ¶ 18,165.

151. Highway Planning Announcement, *supra* note 138, at 2.

152. Entschliessung des Bayerischen Staatministeriums des Innern: Ergänzende Hinweise für die Ausarbeitung und Aufstellung der Bauleitpläne (Supplemental Directive for Developing and Implementing Building Plans) (Sept. 15, 1969) [hereinafter cited as Supplemental Planning Guidelines], *reprinted in* 1 NOISE HANDBOOK, *supra* note 9, ¶ 18,166.

153. *Id.* at 1.

154. Fachkommission Städtebau, Richtlinien für die Berücksichtigung des Verkehrs in Städtebau (Guidelines To Be Used in Considering Traffic in Urban Planning) (Nov. 21, 1968). The Urban Planning Commission is part of a working group established by the Federal Minister for State Affairs. See Supplemental Planning Guidelines, *supra* note 152, at 1.

155. Highway Planning Announcement, *supra* note 138, at 2.

156. *Id.*

157. *Id.*

Construction Announcement, which has already been discussed in conjunction with building measures.<sup>158</sup>

The Highway Planning Announcement concluded that an effective zoning program is based on consideration by zoning authorities of seven different factors:

1. Zoning authorities should require the observance of the spatial separation between highways and structures recommended by DIN 18005.

2. If the recommended spatial separation is not available, zoning authorities should require noise protection measures which are suitable and sufficient in the context of the [1968 Guidelines] and DIN 18005.

3. Zoning authorities should supply highway officials with the information about necessary noise protection measures required by section 2(5) of the BBauG. After receiving this information, highway officials should compile certain data.<sup>159</sup>

4. Zoning authorities should require the notation of noise protection measures which are deemed to be necessary in all building plans submitted to them for their approval.<sup>160</sup> If doubt exists as to whether the necessary noise protection measures have been taken, the Bavarian Office for Environmental Protection<sup>161</sup> can intervene and review those measures for their adequacy.

5. Highway officials should review the building plans in accordance with section 2(6) of the BBauG to determine whether the required spatial separation between highways and structures has been observed. Pursuant to section 9 of the FStrG and article 23ff of the Bavarian Highway and Street Law, they are also called upon to consider the building plans in light of DIN 18005.<sup>162</sup>

6. Plans failing to satisfy the requirements for noise protec-

---

158. See notes 112-20 and accompanying text *supra*.

159. Highway officials are required to compile data about the highway surface, present and projected traffic density, traffic mix, permissible speed limit, etc. Highway Planning Announcement, *supra* note 138, at 3. (If the highway is a local highway, the costs of compiling the required data must be borne by the local government).

160. Noise protection measures must be unequivocally described, including exact measurements. *Id.*

161. Bayerisches Landesamt für Umweltschutz.

162. The Bavarian Office for Environmental Protection should be contacted if there are any reservations about the project. Highway Planning Announcement, *supra* note 138, at 3-4. If these reservations persist, highway officials should communicate their reservations to the local government.

Highway officials play a largely passive role. They are not to enter into a contractual agreement that authorizes the construction of certain noise protection measures. Preliminary Instructions, *supra* note 138, at 3.

tion in urban planning<sup>163</sup> "are not consistent with the well being of the populace and do not serve their safety and health"<sup>164</sup> and should not be approved until all deficiencies have been remedied.<sup>165</sup>

7. In the case of existing zoning regulations, a review of their adequacy in terms of sufficient noise protection should be commenced.<sup>166</sup> No construction contracts should be awarded unless the plans comply with noise protection requirements.<sup>167</sup>

"Noise Control in Highway Planning"<sup>168</sup> is the title of part B of the Highway Planning Announcement. Part B suggests that highway officials consider not only traffic requirements but also "other needs of the populace, particularly a healthy environment" when planning the construction of new major highways.<sup>169</sup> Highway officials should ensure that "traffic noise does not exceed reasonable limits."<sup>170</sup>

---

163. Plans may not satisfy noise protection requirements either because (1) they do not provide for the necessary spatial separation between highways and structures, or (2) they do not provide for the necessary noise protection measures in cases where spatial separation would be impossible or impractical. Highway Planning Announcement, *supra* note 138, at 4.

164. *Id.*

165. *Id.*

166. The determination whether existing zoning regulations provided sufficient noise protection should be made no later than when those zoning regulations are either changed or supplemented. *Id.*

According to the *Kersten Report*, zoning authorities may be reluctant to change or supplement zoning regulations because such an action could trigger the provisions in § 44 of the BBauG and thereby impose on the local government the duty to compensate landowners for a decrease in the value of their property.

Compensation would have to be paid if the use of a structure becomes impermissible under the changed zoning regulations or if the changed zoning regulations limited the use of undeveloped property. KERSTEN REPORT, *supra* note 1, at 5.

No compensation would have to be paid if the change in the zoning regulations does not result in a "significant decrease in the value of the property." *Id.* If there has been a significant decrease, compensation can still be avoided by invoking § 44(1) of the BBauG. This subsection provides that no compensation need be paid if the use which has been approved is subsequently found to be contrary to "the general requirements of healthy living and working conditions." *Id.*

167. KERSTEN REPORT, *supra* note 1, at 5.

168. Lärmschutz in der Strassenplanung.

169. Highway Planning Announcement, *supra* note 138, at 5. "Pursuant to Section 17(4) of the Federal Highway Law and Article 38(2) of the Bavarian Highway and Street Law, proposed noise protection measures, such as walls, embankments, etc., should be set forth with reasonable clarity in the highway plans." Preliminary Instructions, *supra* note 138, at 4. Plans that fail to comply with this requirement are subject to challenge.

170. Highway Planning Announcement, *supra* note 138, at 5. "Where the boundary between reasonable and unreasonable limits lies is disputed." KERSTEN REPORT, *supra* note 1, at 5. The Highway Planning Announcement does not resolve this question but does adopt the guidelines set forth in DIN 18005, *i.e.*, 55 dB(A) during the day and 40 dB(A) at night.

In areas that contain structures requiring protection from noise, the following guidelines should be observed:

1. Highways should be constructed in accordance with recognized rules of highway construction and the highway noise guidelines set forth in the Highway Planning Announcement.<sup>171</sup>

2. Highways should be planned with noise protection requirements, particularly the requirements of DIN 18005, in mind.<sup>172</sup>

3. In addition to DIN 18005, the Federal Institute for Highway's "Measures to Protect Against Traffic Noise" should be used in planning major highways.

Section C of the Highway Planning Announcement is entitled "Analyzing the Route of Planned Major Highways." A principal responsibility of highway officials is to analyze as early as possible the noise impact of various alternative routes of a planned highway.<sup>173</sup> As soon as construction of the highway seems probable, highway officials should inform the affected local government or governments as to the proposed route of the highway and the expected ambient noise level.<sup>174</sup> Local government then would have the responsibility of coordinating zoning regulations

In achieving the goal of keeping traffic noise within reasonable limits, highway officials will be involved in two aspects of zoning. Section 2(5) of the BBauG imposes on highway officials the duties to (1) compile necessary information, "in particular, traffic density, type of vehicles, permissible speed limit, construction of the highway, and projected plans for development," and (2) instruct local governments as to "necessary noise protection measures." Highway Planning Announcement, *supra* note 138, at 5. See note 159 and accompanying text *supra*. These duties apply to existing as well as planned highways. KERSTEN REPORT, *supra* note 1, at 4.

Section 2(6) of the BBauG imposes on highway officials the duty to review building plans. The principal function of this review is to check the distances between highways and structures. Highway Planning Announcement, *supra* note 138, at 5. See also note 162 and accompanying text *supra*.

171. Such construction would result in sufficient spatial separation between the highway and the structures that require protection from noise. Highway Planning Announcement, *supra* note 138, at 5.

172. Ambient noise levels in an area requiring protection from noise should not exceed 55 dB(A) during the day (6:00 a.m. to 10:00 p.m.) and 40 dB(A) at night (10:00 p.m. to 6:00 a.m.). If this goal cannot be achieved at reasonable expense, every effort should be made to keep ambient noise levels below 65 dB(A) during the day and 50 dB(A) at night. Exceptions to the higher ambient noise levels are permitted in the case of individual structures if the higher ambient noise levels can only be achieved at excessive cost or by violating recognized rules of construction. *Id.*

173. *Id.* Analyzing the noise impact of various alternative routes requires highway officials to determine noise zones near the highway and to keep those noise zones free from any structures that should be protected from noise. *Id.* If such a structure is already present, every attempt should be made to accommodate highway requirements and noise protection requirements. Preliminary Instructions, *supra* note 138, at 5.

174. Highway Planning Announcement, *supra* note 138, at 6.

with the highway plans.<sup>175</sup>

In order to familiarize its personnel with the Highway Planning Announcement, the Bavarian Building Department within the Bavarian Ministry of the Interior sponsored seminars on May 16, 1973, in Munich and May 24, 1973, in Nürnberg. These seminars left some unanswered questions. As a result, the Bavarian Building Department sent a letter (1973 Building Department Letter)<sup>176</sup> and additional materials in response to these questions to district governments, the Federal Freeway directorate, and highway construction offices.<sup>177</sup> Appropriate officials were asked to take note of the enclosed materials, to give them due consideration, and to report to the Bavarian Building Department on their experience with enforcement by February 1, 1974.<sup>178</sup> The materials sent with the 1973 Building Department Letter consisted of:

1. "Preliminary Supplemental Instructions"<sup>179</sup> which discuss and answer the technical and legal questions raised by the Highway Planning Announcement;<sup>180</sup>

2. "Noise Protection on Highways" which discusses the physical and technical basis of noise control and gives technical suggestions as to how to comply with the Highway Planning Announcement;<sup>181</sup>

3. VDI 2573,<sup>182</sup> which was published by the Society of German Engineers,<sup>183</sup> and

4. *Noise Control on Major Highways in the Planning Process (Kersten Report)*,<sup>184</sup> which was presented at the seminars in Munich and Nürnberg.

After noting the shift in emphasis from tort and penal remedies to administrative remedies as the principal means of coping

175. If the local government and highway officials cannot agree on the route of the highway, the Bavarian Building Department mediates the dispute. Preliminary Instructions, *supra* note 138, at 5.

176. Letter from Oberste Baubehörde (Bavarian Building Department) to several governmental agencies (Aug. 17, 1973) [hereinafter cited as 1973 Building Department Letter].

177. *Id.* at 1.

178. *Id.* at 2.

179. See note 138 *supra*.

180. 1973 Building Department Letter, *supra* note 176, at 1.

181. *Id.* at 2.

182. Verein Deutscher Ingenieure, VDI-Richtlinien 2573: Schutz gegen Verkehrslärm (Protecting Against Traffic Noise) (Feb. 1974), reprinted in 3 NOISE HANDBOOK, *supra* note 9, ¶ 48,230.

183. See Section V, note 510 and accompanying text *supra*.

184. See note 1 *supra*.

with the problem posed by noise<sup>185</sup> and mentioning the measures that needed to be taken with respect to traffic noise,<sup>186</sup> the *Kersten Report* discussed the growth and development of a law of noise.<sup>187</sup> The *Kersten Report* indicated that "courts have been very cautious in adjudicating complaints based on noise which were made against those responsible for highway construction."<sup>188</sup> As a general rule, the Bundesgerichtshof (Federal Supreme Court) has denied the validity of such claims.<sup>189</sup> This denial has been based on a determination that the noise produced by traffic noise is usual in that vicinity and hence reasonable. As a result, successful noise claims have been the exception rather than the rule.

The *Kersten Report* noted that administrative courts have tended to follow the lead of the Federal Supreme Court.<sup>190</sup> This approach, however, is undergoing some modification. Administrative courts, for example, are increasingly taking the position that section 17(4) of the FStrG creates a responsibility to take special noise precautions, e.g., noise walls and vegetation.<sup>191</sup> Accordingly, administrative courts have ruled that planning decisions are defective if they fail to contain the necessary noise protection measures.<sup>192</sup>

After discussing court decisions,<sup>193</sup> the *Kersten Report* reviewed existing laws and proposals to improve those laws. Two laws—the FStrG<sup>194</sup> and the Bavarian Highway and Street

185. See notes 6-8 and accompanying text *supra*.

186. See note 101 and accompanying text *supra*.

187. KERSTEN REPORT, *supra* note 1, at 2-3.

188. *Id.* at 2.

189. *Id.* In denying the validity of claims against those responsible for highway construction based on noise, the Federal Supreme Court has followed the precedent laid down by its predecessor, the Reichsgericht (German Supreme Court).

190. *Id.*

191. *Id.*

192. *Id.* In 1973, when the *Kersten Report* was prepared, there was no administrative court decision that stated "when and to what degree" noise protection measures are "necessary." *Id.* This situation improved in 1976 when the Bundesverwaltungsgericht (Federal Supreme Administrative Court) explored the limits of reasonableness. See Judgement of May 21, 1976, Bundesverwaltungsgericht, W. Ger., 4 NOISE HANDBOOK, *supra* note 9, ¶ 50,325 (IV C 24.75); Judgement of May 21, 1976, Bundesverwaltungsgericht, W. Ger., 4 NOISE HANDBOOK, *supra* note 9, ¶ 50,326 (IV C 38.74).

193. The German legal system is a civil law system and has traditionally relied on law as found in codes and interpretations of code provisions by legal scholars. The fact that the *Kersten Report* would begin its discussion of the growth and development of a law of noise with a discussion of court decisions is some indication of the growing significance of case law in the German legal system.

194. Bavaria has enacted a law and has passed an ordinance in order to implement the FStG. The law is the Bayerisches Gesetz zum Vollzug des Bundesfernstrassengesetzes

Law<sup>195</sup>—were deemed to be the significant laws with respect to highway construction. A number of changes in the FStrG were being considered at the time the *Kersten Report* was being drafted.<sup>196</sup>

The *Kersten Report* noted that the federal government had proposed amending section 8(8) of the FStrG to provide compensation to an owner whose property is impacted by noise exceeding an ambient noise level of 75 dB(A)<sup>197</sup> and had proposed amending section 17(1) in order to clarify the fact that noise protection is an integral part of the planning process.<sup>198</sup> Bavaria had proposed two further changes that would expand the scope of existing provisions. One change would prohibit the construction of homes along federal highways in areas where the ambient noise level exceeds 65 dB(A).<sup>199</sup> An even stricter ambient noise level of 60 dB(A) would apply for hospitals, rest homes, schools, and other similar structures.<sup>200</sup> Another change would protect adjoining property against “unreasonable annoyance,” danger, and damage.<sup>201</sup> The federal government accepted these proposals and requested that comparable provisions be enacted in state laws.<sup>202</sup>

Section 17(4) of the FStrG provides that the entity constructing a highway is also responsible for constructing and maintaining ancillary facilities.<sup>203</sup> Consequently, no federal highway funds are available if another entity, *e.g.*, a municipality, wishes to construct and maintain facilities that control or abate noise.<sup>204</sup> The *Kersten Report* indicated that the Bavarian Ministry of the

---

(Bavarian Law Implementing the Federal Highway Law), Jul. 25, 1969, [1969] GVBl 182, reprinted in 1 NOISE HANDBOOK, *supra* note 9, ¶ 19,155. The ordinance is the Bayerische Verordnung zur Übertragung der Befugnisse der obersten Landesstrassenbaubehörde nach dem Bundesfernstrassengesetz (Bavarian Ordinance Transferring Authority of State Highway Officials under the Federal Highway Law), Nov. 18, 1974, [1974] GVBl 791, reprinted in 1 NOISE HANDBOOK, *supra* note 9, ¶ 19,160.

195. See note 142 and accompanying text *supra*.

196. The Federal Highway Law was amended in 1974. Some, but not all, of the recommended changes were adopted. For a discussion of the Federal Highway Law, see Section V, notes 549-66 and accompanying text *supra*.

197. KERSTEN REPORT, *supra* note 1, at 2. Apparently, compensation would only have to be paid if two requirements—a significant change in expected use of a structure or structures and an ambient noise level in excess of 75 dB(A)—were satisfied.

198. *Id.* Noise protection should be an integral part of the planning process for public or private projects. *Id.*

199. *Id.* at 3.

200. *Id.*

201. *Id.*

202. *Id.* See note 208 and accompanying text *infra*.

203. KERSTEN REPORT, *supra* note 1, at 3.

204. *Id.* Walls and noiseproof windows were listed as examples of the kinds of facilities another entity might wish to construct and maintain.

Interior had been conducting discussions with the federal Minister of Transportation in the hope that federal funds could be made available for the purpose of constructing and maintaining noise protection facilities.<sup>205</sup> Unfortunately, these discussions proved fruitless.<sup>206</sup>

On March 26, 1974, the Bavarian Legislature enacted the third amendment to the Bavarian Highway and Street Law, which went into effect on July 1, 1974.<sup>207</sup> Section 13 of this amendment changes article 25 of the Bavarian Highway and Street Law to provide as follows:

On free stretches of state and local highways and on connecting highways within municipalities, residences may not be constructed in areas where the ambient noise level exceeds 65 dB(A), and hospitals, rest homes, schools, and similar structures deserving protection from noise may not be constructed where the ambient noise level exceeds 60 dB(A) . . . .<sup>208</sup>

Article 25(1) also authorizes the government of Bavaria to establish a procedure to determine ambient noise levels.<sup>209</sup>

The requirements of article 25(1) do not apply to a residence that satisfies the conditions of article 25(2), namely: (1) the use of the residence is consistent with the requirements of a building plan as specified in the BBauG, (2) the minimum spatial separation between the highway and the structure to be constructed has been observed, (3) noise impact has been considered, and (4) highway officials have participated in the development of the building plans.<sup>210</sup> In addition, article 25(1) provides for exceptions "when it can be demonstrated that the use of the particular structure will be sufficiently protected from the effects of noise."<sup>211</sup>

On March 15, 1974, the Bundestag enacted the Federal Ambient Levels Protection Law.<sup>212</sup> Section 43<sup>213</sup> of the BImSchG au-

205. *Id.*

206. Letter from Bavarian State Ministry of the Interior to the author (May 11, 1978).

207. Bavarian Highway and Street Law, *supra* note 142, art. 25(1).

208. *Id.* The third amendment to the Bavarian Highway and Street Law is Bavaria's response to a request by the federal government.

209. *Id.*

210. *Id.* art. 25(2).

211. *Id.* art. 25(1).

212. See Section V, note 532 and accompanying text *supra*.

Bavaria has passed an ordinance to implement the BImSchG. This ordinance is the Bayerische Verordnung über die Festsetzung von Belastungsgebieten nach dem Bundes-Immissionsschutzgesetz, Apr. 29, 1976, [1976] GVBl 176, reprinted in 3 NOISE HANDBOOK, *supra* note 9, ¶ 35,161.

213. For a discussion of § 43 of the BImSchG, see Section V, notes 607-09 and accompanying text *supra*.



thorizes the federal government to issue regulations (section 43 regulations) that will implement sections 41 (situations that call for noise abatement measures or damages)<sup>214</sup> and 42 (noise abatement measures, damages).<sup>215</sup>

The Bavarian Building Department responded to the enactment of the BImSchG by sending a letter dated May 6, 1974 (1974 Building Department Letter) entitled "Noise Protection in Highway Construction"<sup>216</sup> to various governmental authorities.<sup>217</sup> The 1974 Building Department Letter suggested that local governments should continue to use the Highway Planning Announcement, particularly part B, when constructing new highways,<sup>218</sup> until section 43 regulations were issued.<sup>219</sup>

There were no section 43 regulations on May 6, 1974, nor was there any prospect that such regulations would be issued in the foreseeable future.<sup>220</sup> The absence of such regulations created a variety of problems and led the Bavarian Building Department to recommend postponing any decisions as to noise abatement measures or damages until the section 43 regulations were issued.<sup>221</sup>

On October 8, 1974, the Bavarian Legislature enacted the Bavarian Ambient Levels Protection Law (BayImSchG).<sup>222</sup> The

214. For a discussion of § 41 of the BImSchG, see Section V, notes 599-601 and accompanying text *supra*.

215. For a discussion of § 42 of the BImSchG, see Section V, notes 602-06 and accompanying text *supra*.

216. Letter from Oberste Baubehörde (Bavarian Building Department) to several governmental agencies (May 6, 1974) [hereinafter cited as 1974 Building Department Letter].

217. The distribution of the 1974 Building Department Letter was even broader than that of the 1973 Building Department Letter. In addition to district governments, the Federal Freeway Directorate, and highway construction offices, the 1974 Building Department Letter was sent to county and local governments.

218. 1974 Building Department Letter, *supra* note 216, at 1-2. See also note 147 *supra*.

219. *Id.*

220. The regulations authorized by § 43 have not been issued.

221. 1974 Building Department Letter, *supra* note 216, at 2.

The absence of § 43 regulations created two major problems. One problem was how to handle cases where noise abatement measures or damages were sought under § 42. The 1974 Building Department Letter recommended postponing any decisions on these matters until the § 43 regulations were issued. *Id.* The other problem was what constitutes a noticeable increase. The 1974 Building Department Letter defined a noticeable increase as a 4 dB(A) increase, borrowing that figure from section 4(2) of the Law to Protect Against Aircraft Noise. *Id.*

222. Bayerisches Immissionsschutzgesetz (Bavarian Ambient Levels Protection Law), Oct. 8, 1974, [1974] GVBl 499, as modified by Law of Jul. 23, 1976, [1976] GVBl

BayImSchG is divided into three parts. Article 11 in part II prohibits activities between the hours of 10:00 p.m. and 7:00 a.m. that would disturb sleeping individuals.<sup>223</sup> Unnecessary idling of a motor is prohibited by article 12.<sup>224</sup>

The Bavarian Ministry of the Interior sent a letter dated December 15, 1976, (1976 Ministry of Interior Letter) entitled "Noise Protection in Highway Construction"<sup>225</sup> to district governments, zoning authorities, and highway construction offices. The 1976 Ministry of Interior Letter noted that no section 43 regulations had been issued and advised local governments to continue to use the Highway Planning Announcement until further notice was given.<sup>226</sup>

The 1976 Ministry of Interior Letter recommended that careful attention be given to noise protection in planning and building major highways.<sup>227</sup> Particular attention should be given to noise protection on highways through residential areas or other areas deserving protection from noise.<sup>228</sup> In deciding where to locate a highway and choosing its surface, every effort should be made to minimize noise as much as possible.<sup>229</sup>

If the projected ambient noise levels exceed those levels recommended by DIN 18005,<sup>230</sup> active noise abatement measures would be warranted. Table VI-2<sup>231</sup> summarizes the ambient noise levels recommended for planning purposes by the 1976 Ministry of Interior Letter.

---

294 [hereinafter cited as BayImSchG], *reprinted in* 3 NOISE HANDBOOK, *supra* note 9, ¶ 35,155.

223. *Id.* art. 11(1). Some activities are not subject to the prohibition. *Id.* art. 11(2). Other activities, subject to the prohibition, constitute an exception because they are unavoidable. *Id.* art. 11(3). Local governments are authorized to make further exceptions to the prohibition where an exception would be in the public interest. *Id.* art. 11(4).

224. *Id.* art. 12(1)(1). Exceptions are possible. *Id.* art. 12(2).

225. Letter from Bayerisches Staatsministeriums des Innern (Bavarian Ministry of the Interior) to several governmental agencies (Dec. 15, 1976) [hereinafter cited as 1976 Ministry of Interior Letter]. The subject of the 1976 Ministry of Interior Letter was identical to the subject of the 1974 Building Department Letter. See notes 216-21 and accompanying text *supra*.

226. 1976 Ministry of Interior Letter, *supra* note 225, at 1.

227. *Id.*

228. *Id.* at 2.

229. *Id.*

230. See Table V-8 *supra*.

231. Table VI-2 is based on information found in the 1976 Ministry of Interior Letter, *supra* note 225, at 2.

TABLE VI-2

Land-Use Category	Ambient Noise Level (in dB(A))	
	Day	Night <sup>232</sup>
Pure residential; general residential; special residential; and small housing <sup>233</sup>	55	45
Village; mixed <sup>234</sup>	65	55

In addition to the land-use categories in Table VI-2, there is also a "special" land-use category. The 1976 Ministry of Interior Letter indicated that recommended ambient noise levels for this category should be determined on a case-by-case basis.<sup>235</sup>

A distinction was drawn in the 1976 Ministry of Interior Letter between areas that are "impacted in fact" and areas that are "impacted in the planning sense." If an area is impacted in fact—the new highway will result in a significant increase in the ambient noise level—active noise abatement measures are required.<sup>236</sup> The 1976 Ministry of Interior Letter defined a significant increase as an increase of "more than 3 dB(A)."<sup>237</sup>

Noise abatement measures can be dispensed with if their cost is disproportionate to the benefits derived.<sup>238</sup> The 1976 Ministry of Interior Letter interpreted this exception narrowly. Costs are proportionate to benefits if the difference between the cost of installing the noise abatement measure and the damages that would otherwise have to be paid is small.<sup>239</sup>

232. Nighttime is the time between 10:00 p.m. and 6:00 a.m. *Id.*

233. These land-use categories correspond to land-use categories 1-4 in the BauNVO. See Section V, note 546 and accompanying text *supra*.

234. These land-use categories correspond to land-use categories 5 and 6 in the BauNVO. See Section V, note 546 and accompanying text *supra*.

235. 1976 Ministry of Interior Letter, *supra* note 225, at 2.

236. *Id.* at 3.

237. *Id.* Contrast this definition of significant increase (more than 3 dB(A)) with the definition of noticeable increase in the 1974 Building Department Letter (more than 4 dB(A)).

Since the decimal scale is logarithmic, an increase of 4 dB(A) is equal to an increase of approximately 40%. See Section I, note 15 *supra*. In defining significant increase, the 1976 Ministry of Interior Letter adopts a stricter standard of 3 dB(A), or approximately 30%.

238. Both § 17 of the FStrG and § 41 of the BImSchG permit dispensing with noise abatement measures if their cost is out of proportion to the benefits to be derived. See Section V, notes 557, 600-01 and accompanying text *supra*.

239. 1976 Ministry of Interior Letter, *supra* note 225, at 3. "[T]he cost difference must be significant." *Id.*

The Highway Planning Announcement applies to significant modifications of existing highways as well as to construction of new highways. What then is a significant modification as that term is used in section 41 of the BImSchG? According to the 1976 Ministry of Interior Letter, a modification is significant if it alters the construction of the highway *and* causes an increase in the ambient noise level of more than 3 dB(A).<sup>240</sup>

On April 27, 1977, the Bavarian Ministry for Land Development and the Environment published an announcement entitled "Enforcing the Federal Ambient Levels Protection Law and the Bavarian Ambient Levels Protection Law (Enforcement Announcement)."<sup>241</sup> The Enforcement Announcement is divided into three sections: section A, which discusses the BImSchG; section B, which discusses the BayImSchG; and section C, which lists previous announcements that were revoked by publication of the Enforcement Announcement.

### C. Enforcement

There are four different levels of government in Bavaria. The highest level is the state government headed by a state minister. Below the state government are seven district governments, each headed by an administrative president. Below the district governments are more than seventy county governments, each headed by a county magistrate. Below the county governments are 4000 municipalities.

The state government is divided into eight ministries. Although several ministries are involved with noise problems,<sup>242</sup> the Ministry for Land Development and the Environment is principally responsible for controlling and abating noise.<sup>243</sup> The Ministry for Land Development and the Environment is divided into three departments: Central Duties, Land Development, and En-

---

240. *Id.* (emphasis in original).

241. Bekanntmachung des Bayerischen Staatsministerium für Landesentwicklung und Umweltfragen betreffend Vollzug des Bundes-Immissionsschutzgesetzes und des Bayerischen Immissionsschutzgesetzes (Enforcing the Federal Ambient Levels Protection Law and the Bavarian Ambient Levels Protection Law) (1977) [hereinafter cited as Enforcement Announcement], reprinted in 3 NOISE HANDBOOK, *supra* note 9, ¶ 35,167.

242. For example, the Ministry of the Interior is responsible for highway construction, and the Ministry of Commerce and Transportation is responsible for motor vehicles.

243. See Bayerisches Gesetz über die Zuständigkeiten in der Landesentwicklung und in den Umweltfragen (Bavarian Law of Land Development and Environmental Authority), Feb. 19, 1971, [1971] GVBl 65, as modified by Law of Jul. 23, 1976, [1976] GVBl 294. Selected excerpts are reprinted in 1 NOISE HANDBOOK, *supra* note 9, ¶ 27,155.

vironment. The Department of the Environment<sup>244</sup> consists of an administrative/legal division and an environmental control and technology division.

The Ministry for Land Development and the Environment is assisted by the Bavarian Office for Environmental Protection. Within this office is a division for air, noise, and vibration. Four sections in this division deal with air; the remaining three sections deal with noise and vibration.

---

244. Hauptabteilung-Umweltfragen.

## SECTION VII

### REGULATION OF TRAFFIC NOISE IN MUNICH

Traffic is the major source of noise in Munich.<sup>1</sup> Test results indicate that ambient noise levels on major streets vary from a low of 79 dB(A) to a high of 84 dB(A).<sup>2</sup> As a result, the people of Munich consider noise to be one of the most serious environmental problems confronting their city.<sup>3</sup>

#### A. *The Law*

The only law in Munich dealing directly with noise is the Household Work and Music Noise Regulation.<sup>4</sup> One might draw from this fact the conclusion that local government in general and Munich in particular is unconcerned about the seriousness of noise as an environmental problem. Such a conclusion would be

---

1. LANDESHAUPTSTADT MÜNCHEN, STADTENTWICKLUNGSREFERAT, KOMMUNALPOLITISCHE ASPEKTE DES UMWELTSCHUTZES IN MÜNCHEN (The Municipal-Policy Aspects of Environmental Protection in Munich) 41 (1971) (Arbeitsberichte zur Fortschreibung des Stadtentwicklungsplans - Nr. 3) [hereinafter cited as 1971 REPORT]. See also Letter from Mr. Kahl, Director of Administration for the City of Munich, to the author (May 5, 1978) [hereinafter cited as 1978 Letter].

2. Referat für Kreisverwaltung und öffentliche Ordnung, Einbau schalldämmender Fenster (Installation of Noiseproof Windows) 4 (May 14, 1974) (Antrag Nr. 297 der Stadtratsfraktion der SPD vom 27. November 1973) [hereinafter cited as 1974 Report]. Noise peaks of 90 dB(A) on these same streets are not exceptional. *Id.* at 2.

3. *Id.* at 14. The author is unaware of any questionnaire that has asked the people of New York City to rank environmental problems in the order of their perceived seriousness. However, the likelihood that the people of New York City would list noise as the most serious environmental problem confronting their city is remote in this author's judgment.

4. München, Gemeindeverordnung über die zeitliche Beschränkung ruhestörender Haus- und Gartenarbeiten und über die Benutzung von Musikinstrumenten, Tonübertragungs- und wiedergabegeräten in der Landeshauptstadt München (Hausarbeits- und Musiklärmverordnung) (June 20, 1968) [hereinafter cited as the Household Work and Music Noise Regulation].

The Household Work and Music Noise Regulation is divided into four sections. Section 1 deals with household work noise. Household work noise includes, but is not limited to, noise caused by beating carpets, furniture, or bedding; noise caused by hammering; noise caused by sawing or hacking wood; and noise caused by the use of a lawn mower propelled by an internal combustion engine. Household work activities that cause such noise can only be carried on from 8:00 a.m. until noon on Mondays through Saturdays, 3:00 p.m. to 6:00 p.m. on Mondays through Fridays, and 3:00 p.m. to 5:00 p.m. on Saturdays. Section 2 deals with noise from musical instruments or transmitters or receivers of sound. All of these instruments are to be used so as to avoid unnecessary noise, particularly after 10:00 p.m.

The Household Work and Music Noise Regulation came into force on July 5, 1968, and will remain in force for 20 years. *Id.* § 4. A person who intentionally or negligently violates its provisions is subject to a fine of DM 1000. *Id.* § 3. DM 1000 is equivalent to approximately \$500.

erroneous. A series of "proposals"<sup>5</sup> and corresponding reports<sup>6</sup> trace a growing awareness of the seriousness of traffic noise as an environmental problem. They also graphically portray the rather limited noise abatement options available to Munich because of the pervasiveness of federal and state regulation of traffic noise.

### B. The Reports

#### 1. The 1962 Report

Measures for Noise Control at the Municipal Level (the 1962 Report),<sup>7</sup> written in response to Proposal No. 273, defined noise, described the measurement of noise, explored the effects of noise on public health and welfare,<sup>8</sup> and discussed four noise sources,<sup>9</sup> including traffic noise. In its discussion of traffic noise, the 1962 Report was sharply critical of sections 29 and 49 of the Motor Vehicle Approval Ordinance (StVZO).<sup>10</sup>

Section 29<sup>11</sup> provides for periodic testing of motor vehicles

5. The German term for proposal is "Antrag."

6. The German terms for report are "Referat" and "Bericht."

7. Referat für Kreisverwaltung und öffentliche Ordnung, Lärmbekämpfungsmassnahmen in der Gemeindeebene (Measures to Control Noise at the Municipal Level) (1962) [hereinafter cited as 1962 Report].

8. The 1962 Report discusses the research of Dr. von Tischendorf of the German Medical Information Service and Dr. Lehmann of the Max Planck Institute of Labor Physiology. Dr. von Tischendorf distinguishes between three different noise levels. The first and lowest level "annoys"; the second level "endangers" health; and the third and highest level "damages" health. According to Dr. von Tischendorf, the single most important objective in controlling and abating noise should be to ensure an undisturbed sleeping period of from seven to nine hours. 1962 Report, *supra* note 7, at 4-5.

Dr. Lehmann also distinguishes between three different noise levels. The following table outlines these different noise levels and their effects.

Noise Level	Effects
30 to 60 Phon	Psychological effects
65 to 90 Phon	Psychological and vegetative effects
90 to 120 Phon	Psychological, vegetative, and otological effects

*Id.* at 6.

9. The four noise sources discussed are traffic noise, industrial noise, construction noise, and aircraft noise. *Id.*

10. For a discussion of the StVZO, see Section V, notes 143-84, 223-72, 287-91, 298-310, 335-47 and accompanying text *supra*.

11. For a discussion of § 29 of the StVZO, see Section V, notes 227-72 and accompanying text *supra*.

throughout their useful lives. According to the 1962 Report, periodic testing was ineffective. One contributing factor was exceptions to the general requirement that every motor vehicle undergo periodic testing.<sup>12</sup> The limited capabilities of the testing stations maintained by the "Technical Control Associations" (TÜV)<sup>13</sup> that conducted most of the periodic testing were another contributing factor.<sup>14</sup> As a result, the police, by default, had acquired the responsibility of monitoring all motor vehicles in use. They were forced to make subjective judgments about noise emissions and to refer the suspected offender to TÜV for confirmation of their suspicions.

Section 49<sup>15</sup> regulates noise emissions by motor vehicles. In the version of section 49 that became effective on March 29, 1956, a "best available technology" standard was substituted for the 85 Phon standard in the previous version.<sup>16</sup> The rationale for the change was that the application of this standard would result in a continuing downward adjustment in the noise emission standard until "quiet" motor vehicles were achieved. This standard presupposes that the technology is available, has been tested, and can be used at reasonable cost. Moreover, this standard assumes that a noise emission standard consistent with best available technology can be determined. According to the 1962 Report, the noise emission standards dictated by best available technology were "easy to recognize but difficult to determine."<sup>17</sup> "Best available technology" in 1962 meant noise emission standards ranging from 75 to 87 Phon for motor vehicles.<sup>18</sup> These noise emission standards were simultaneously "too much" and "too little."<sup>19</sup> The 1962 Report also pointed out that section 49 did not cover noisy

---

12. One such exception was granted for "in-house" inspections, *i.e.*, inspections conducted by the owner in his own facilities. If the owner had personnel who possessed the requisite ability to conduct periodic testing, he could obtain permission to allow his own personnel to conduct in-house inspections on his motor vehicles. 1962 Report, *supra* note 7, at 9.

13. Technische Überwachungs-Vereine (TÜV).

14. 1962 Report, *supra* note 7, at 9. This author has received conflicting reports on the effectiveness of the noise phase of periodic testing. Some officials claim that the noise phase is perfunctory; other officials claim that rigorous attention is given.

15. For a discussion of § 49 of the StVZO, see Section V, notes 298-302 and accompanying text *supra*.

16. The previous version of § 49 of the StVZO was effective up to April 1, 1952. 1962 Report, *supra* note 7, at 8. Apparently the 85 Phon standard lapsed before the "best available technology" standard became effective on March 29, 1956.

17. *Id.*

18. *Id.*

19. *Id.* Manufacturers considered the best available technology standards "too much"; individuals subject to motor vehicle noise emissions considered them "too little."



motor vehicle doors. This omission was considered to be a serious oversight.<sup>20</sup>

## 2. *The 1968 Overview Report*

Overview of the Noise Control Situation and the Possibilities for Noise Control (the 1968 Overview Report)<sup>21</sup> summarized the noise control situation and the possibilities for noise control as they existed in 1968. According to the 1968 Overview Report, noise control raises "administrative, criminal, civil, [and] constitutional questions."<sup>22</sup> The 1968 Overview Report listed some of the federal and state noise laws. Many of these laws were based on the best available technology standard. Individuals who had to enforce these laws were not entirely satisfied with this standard. Their dissatisfaction was summarized by the 1968 Overview Report in the following language:

How is the enforcement authority to recognize best available technology or to fix the limits of the activities of an industrial plant? Where does unnecessary noise begin and where does necessary noise end? Does the boundary exist where technology no longer permits or where production is endangered? Is the decision left to the enforcement authority within the realm of its judgment? If so, then there are theoretically 7050 different opinions, as far as towns are concerned, and 177 opinions, as far as cities are concerned, in Bavaria alone.<sup>23</sup>

Since the people of Munich viewed traffic noise as the most pressing noise problem,<sup>24</sup> control of motor vehicle noise was given considerable attention in the 1968 Overview Report. One means of controlling motor vehicle noise was the "type test" required of new vehicles by section 20 of the StVZO.<sup>25</sup> Table VII-1<sup>26</sup> summa-

20. According to the 1962 Report, "motor vehicle doors which can only be closed with noise and through the application of moderate force" are inconsistent with best available technology. *Id.*

21. Referat für Kreisverwaltung und öffentliche Ordnung, Übersicht über den Stand und die Möglichkeiten der Lärmbekämpfung (Overview of the Noise Control Situation and the Possibilities for Noise Control) (1968) [hereinafter cited as 1968 Overview Report].

22. *Id.* at 1.

23. *Id.* at 5. There continues to be considerable dissatisfaction with the standard of best available technology. One official with whom the author spoke in June 1974 termed this standard "meaningless."

24. *Id.* at 7.

25. The 1968 Overview Report mentions § 49 of the StVZO in connection with "type tests." The regulations for type tests are issued pursuant to § 49, but the type test itself is described in § 20. For a discussion of type tests, see Section V, notes 164-84 and accompanying text *supra*.

26. Table VII-1 is based on information found in the 1968 Overview Report, *supra* note 21, at 7.

izes the noise emission standards in effect at the time the 1968 Overview Report was written.

TABLE VII-1

Type of Vehicle	Noise Emission Standard (in dB(A))
Motor vehicles under 70 horsepower/ton	80
Motor vehicles over 70 horsepower/ton	84
Trucks and buses under 3.5 tons	85
Trucks and buses over 3.5 tons	89
Motor vehicles over 200 horsepower	92
Motorcycles	84

The 1968 Overview Report quoted at length from a study entitled "Community Traffic Problems in the Federal Republic of Germany."<sup>27</sup> This study listed various components of motor vehicle noise and suggested noise control techniques. When the study was submitted to the federal government, the Ministry of Transportation issued the following comment:

As a result of improvements in motor vehicles, the permissible noise levels found in the regulations issued pursuant to Section 49 have been reduced on four separate occasions in the last 10 years. Our expectation is that international regulations setting permissible noise levels and establishing measurement methodology will be issued in the near future. The Commission for the European Economic Community, with the participation of the Federal Republic of Germany, has already begun its work in this respect. . . . Minimizing unnecessary noise through proper maintenance of motor vehicles and operational control is the responsibility of the police and [TÜV]. Personnel who are responsible for administering traffic regulations must give the noise aspect of these regulations and their enforcement greater attention.<sup>28</sup>

27. *Id.* at 8 (citing I.W. Hollatz & F. Thamms, *Die Kommunalen Verkehrsprobleme in der Bundesrepublik Deutschland* (Community Traffic Problems in the Federal Republic of Germany) (1965)). This study was conducted under a Ministry of Transportation grant. A section of the study was devoted to the following question: "Question 8: What measures are available to the people to protect themselves against the harmful effects of transportation (noise, air pollution)?" *Id.*

28. 1968 Overview Report, *supra* note 21, at 9.

Another study, which was rather pessimistic about the willingness of manufacturers to keep noise emissions at the lowest possible level and to continually reduce noise emission standards, was also mentioned.<sup>29</sup> The author of that study concluded that the only way to achieve the lowest possible noise emission levels was to change the taxing system for motor vehicles. Motor vehicles were being taxed on the basis of displacement, and according to the author of that study, this encouraged "noisy" rather than "quiet" motor vehicles.

The 1968 Overview Report also referred to a "Crisis Program" developed at a Ministry of Transportation Conference held on November 23, 1966.<sup>30</sup> The "Crisis Program" outlined seven steps to be taken immediately to control noise:

- (1) intensified supervision of the construction provisions of the Motor Vehicle Approval Ordinance;
- (2) emphatic action with respect to the following causes of traffic noise:
  - (a) unnecessary idling or racing of the engine;
  - (b) unnecessary use of the horn;
  - (c) unnecessary trips by motor vehicles;
  - (d) noisy closing of motor vehicle doors;
  - (e) unnecessary noise resulting from loading or unloading motor vehicles;
  - (f) improperly maintained muffler; and
  - (g) defective construction;
- (3) voluntary testing of motor vehicles by associations, firms, and repair shops;
- (4) greater attention to noise emissions during the motor vehicle test provided for in section 29 of the Motor Vehicle Approval Ordinance;
- (5) taxation of motor vehicles so as to reduce noise and emissions;
- (6) an appeal to motorists to exercise discipline; and
- (7) an information program for the general public.<sup>31</sup>

---

29. *See id.* at 10. This other study is not mentioned by name but was prepared for and presented to the Traffic/Police Committee on February 11, 1965. The author of this other study saw a conflict between motor vehicle manufacturers and the noise-tormented populace: "What appears to industry as the achievable in reducing noise is always too much noise for the noise-tormented populace." *Id.* Because of this conflict, the author maintained that manufacturers must be prodded through legal sanctions to improve their products.

30. *Id.*

31. *Id.* at 10-11.

### 3. *The 1968 Urban Noise Report*

On June 9, 1967, the Senior Council of the Munich City Council decided to form a working group whose function was to recommend new laws or changes in existing laws that would lead to a reduction in noise. This working group studied aircraft noise, traffic noise, construction noise, and industrial noise. Its report, *Controlling Urban Noise; Results of the Deliberations of the Working Group of the City Council (the 1968 Urban Noise Report)*,<sup>32</sup> was submitted to the City Council on July 24, 1968.

The working group concluded that the "political climate" in Bonn was favorable to legislative proposals.<sup>33</sup> It recommended, however, that proposals directed at selected problem areas had a greater probability of success than one general noise proposal.

The working group specifically recommended that Munich set a favorable example for its citizens by working closely with its personnel who were responsible for enforcing noise provisions.<sup>34</sup> In addition, the populace should be periodically encouraged to do its part in the campaign to reduce noise.<sup>35</sup>

Traffic noise received only passing attention in the 1968 Urban Noise Report. By the time the report was written, noise emission standards had become international, as the Ministry of Transportation had predicted, due to the adoption of the European Economic Community Directive "on the approximation of the laws of the Member States relating to the permissible sound level and the exhaust system of motor vehicles."<sup>36</sup> There was no expectation that these noise emission standards would be changed at the national level. The responsibility for enforcing these noise emission standards belonged to the police.<sup>37</sup> Conse-

32. Referat für Kreisverwaltung und öffentliche Ordnung, *Bekämpfung des Grossstadtlärms; Ergebnisse der Beratung der Arbeitsgruppe des Stadtrats (Controlling Urban Noise; Results of the Deliberations of the Working Group of the City Council)* (July 24, 1968) [hereinafter cited as 1968 Urban Noise Report].

33. *Id.* at 1.

34. "[W]ith the city government a visible attempt should be made to avoid creating unnecessary noise." *Id.* at 2. This recommendation was specifically directed at those departments of city government involved in any way with construction and maintenance.

35. The 1968 Urban Noise Report did not indicate what the populace could do in the campaign to reduce noise.

36. 13 J.O. COMM. EUR. (No. L 42) 16 (1970) (English version at 1970(I) O.J. EUR. COMM. 111 (Spec. ed. 1972)). For a discussion of the European Economic Community Directive "on the approximation of the laws of the Member States relating to the permissible sound level and the exhaust system of motor vehicles," see Section V, notes 366-413 and accompanying text *supra*.

37. The "Crisis Program," notes 30-31 and accompanying text *supra*, was viewed as

quently, the working group recommended a close working relationship between the police and TÜV. The working group also recommended that further attention be given to the possibilities of reducing noise through the operation of motor vehicles and/or the design of highways.<sup>38</sup>

#### 4. *The 1970 Report*

Nighttime Operational Prohibitions for Mopeds, Motorcycles, and Trucks; Technical Requirements for Construction Equipment (the 1970 Report)<sup>39</sup> was written in response to Proposal No. 234, which was submitted by the Social Democratic Party faction in the City Council, asking the City Council to authorize an investigation of the following questions: "(a) What legal possibilities exist . . . through restrictions on the use of motorcycles and trucks during evening hours or through technical requirements for construction machinery to abate ever increasing city noise; (b) What proposals can Munich make to create missing legal prerequisites?"<sup>40</sup> Traffic noise and construction noise were considered in the context of these two questions.

The section on traffic noise in the 1970 Report began with a discussion of laws both presently in effect and those scheduled to take effect at a future date. Even in the cases where the existing laws<sup>41</sup> had been vigorously enforced, they had failed to reduce traffic noise.<sup>42</sup> The expectation was that certain amendments to the Motor Vehicle Ordinance (StVO),<sup>43</sup> which became effective on March 1, 1971, might improve the situation.<sup>44</sup>

---

describing the actions the police should be taking. 1968 Urban Noise Report, *supra* note 32, at 3.

38. 1968 Urban Noise Report, *supra* note 32, at 3.

39. Referat für Kreisverwaltung und öffentliche Ordnung, Nächtliche Fahrverbote für Mopeds, Motorräder und Lastkraftwagen; Technische Auflagen für Baumaschinen (Nighttime Operational Prohibitions for Mopeds, Motorcycles, and Trucks; Technical Requirements for Construction Equipment) (Dec. 10, 1970) [hereinafter cited as 1970 Report].

40. *Id.* at 1.

41. The existing laws referred to by the 1970 Report include §§ 1 (operation), 30 (construction), and 49 (noise emissions) of the Motor Vehicle Ordinance (StVO) and art. 18f (idling and use of motor vehicles and motorcycles on private streets) of the Bavarian Penal Law and Regulations (LStVG). *Id.* at 2.

42. *Id.*

43. For a discussion of the Motor Vehicle Ordinance (StVO), see Section V, notes 82-142 and accompanying text *supra*.

44. In addition to § 45 of the StVO, see notes 45-47 *infra*, §§ 22 (unnecessary noise arising from the transport of freight), 30 (unnecessary idling; unreasonable noise arising from closing motor vehicle doors; unnecessary to and fro driving), and 33 (loudspeakers) had been amended. See 1970 Report, *supra* note 39, at 2.

Section 45 of the StVO,<sup>45</sup> which empowers enforcement personnel to impose driving curfews in residential areas during evening hours, was considered the most important of these amendments. Driving curfews, however, could not be imposed without the approval of the Bavarian government, and this approval had not yet been given.<sup>46</sup>

Section 45 requires a series of difficult and complex decisions:

- (1) Should or could traffic limitations be imposed on individual streets or on residential areas?
- (2) Are trailers included in or excluded from the limitations?
- (3) Does a decrease in noise on one street result in an increase in noise on a parallel street?
- (4) Does Munich have the capacity to enforce the limitations?<sup>47</sup>

The 1970 Report drew several tentative conclusions with respect to these decisions. First, exceptions to the limitations had to be made for principal streets. Second, enforcement personnel had two options: (1) speed limitations or (2) operational limitations. The appropriate action was to be selected on a case-by-case basis.<sup>48</sup>

Either option—speed limitations or operational limitations for certain types of vehicles—required an examination of the sources of motor vehicle noise. As a result, the 1970 Report examined these sources and placed them in four categories.<sup>49</sup> One source was the vehicle itself. Noise reduction possibilities with respect to this source were limited to controlling the flow and speed of traffic. Brakes were another source. This source could be influenced by maintaining the flow of traffic. The more frequently the flow of traffic is broken, the more serious the problem of brake noise. A third source was the highway surface. Munich suffers from the fact that many of its streets are cobblestone streets. Unreasonable operation of the vehicle and tires with spikes were listed as “other” noise sources.

After reviewing the four sources of motor vehicle noise, the 1970 Report discussed what was being done and what could have

---

45. For a discussion of § 45 of the StVO, see Section V, notes 120-30 and accompanying text *supra*.

46. 1970 Report, *supra* note 39, at 3.

47. *Id.*

48. *Id.*

49. *Id.* at 4.

been done under existing laws. Cobblestone streets were being covered with asphalt. Brake noise could have been reduced, particularly between 10:00 p.m. and 6:00 a.m., by turning off traffic signals, thereby contributing to a continuing traffic flow. However, this proposal, while desirable from the standpoint of noise reduction, was undesirable from the standpoint of safety and could only be used on a limited basis.<sup>50</sup>

The 1970 Report suggested that the police be encouraged to make a greater effort to monitor traffic for possible violators.<sup>51</sup> A propaganda program directed at motorists was proposed.<sup>52</sup> The 1970 Report recommended that the federal government change the current tax system, which is based on displacement, because taxation on that basis encourages noisy motor vehicles.<sup>53</sup>

### 5. *The 1971 Report*

Six different proposals—Nos. 254,<sup>54</sup> 255,<sup>55</sup> 260,<sup>56</sup> 265,<sup>57</sup> 267,<sup>58</sup> and 285<sup>59</sup>—dealing with a variety of environmental problems and containing forty separate points—were submitted to the City Council for its consideration between January 4, 1971, and May 14, 1971. The problem of noise was raised in three of the six proposals. Numbers 255 and 285 called for traffic noise control. Number 255 proposed measures that would interrupt the flow of

50. *Id.* at 5. Munich experimented with turning off traffic signals in Schwabing, the Bohemian section of the city, and discovered that the number of accidents in that section rose significantly as a result.

51. *Id.* A joint effort by the police and the city government during the period Sept. 14-18, 1970, had been particularly successful.

52. *Id.* The 1970 Report proposed that automobile clubs be invited to participate in the propaganda program.

53. *Id.*

54. Proposal No. 254 was introduced by the Social Democratic Party (SPD) faction in the City Council on Jan. 4, 1971, and was entitled "Luftverschmutzung in der Münchener Innenstadt" (Air Pollution in the Munich Inner City). 1971 REPORT, *supra* note 1, at 13.

55. Proposal No. 255 was introduced by the All German Party (GDP) faction in the City Council on Jan. 9, 1971, and was entitled "Umweltschutz" (Environmental Protection). *Id.*

56. Proposal No. 260 was introduced by the Christian Social Union (CSU) faction in the City Council on Jan. 20, 1971, and was entitled "Grossversuche mit abgasfreien Fahrzeugen" (Experimentation with Exhaust-Free Motor Vehicles). *Id.*

57. Proposal No. 265 was introduced as an addition to Proposal No. 254. *Id.*

58. Proposal No. 267 was introduced by the CSU faction in the City Council on Feb. 8, 1971, and was entitled "Abgasüberwachung in München, Ankauf und Einsatz von Prüfgeräten durch die Stadt" (Monitoring Exhausts in Munich: Purchase and Use of Measurement Devices Throughout the City). *Id.*

59. Proposal No. 285 was introduced by the GDP faction in the City Council on May 14, 1971, and was entitled "Umweltschutz" (Environmental Protection). *Id.*

through traffic in residential areas and improve the flow of through traffic on major highways.<sup>60</sup> Number 285 recommended the preparation of a noise map for residential areas in Munich. In addition, three of the proposals—Nos. 254, 255, and 285—called for aircraft noise control.

In response to this series of proposals a working group was formed, which under the auspices of the Office of City Development<sup>61</sup> prepared a report: *The Municipal-Policy Aspects of Environmental Protection in Munich* (the 1971 Report).<sup>62</sup>

In the foreword to the 1971 Report, the authors indicated that the people of Munich were already plagued by noise that frequently exceeded the limits established by noise emission standards,<sup>63</sup> and the situation was expected to deteriorate rather than improve. The 1971 Report revealed that sixty-three percent of the population felt their lives were disturbed by noise.<sup>64</sup> The five most important noise sources listed by the authors were: (1) motor vehicles, (2) aircraft, (3) streetcars, (4) construction sites, and (5) industry.<sup>65</sup>

Using models, the authors estimated that ambient noise levels on streets varied from 75 to 90 Phon on heavily traveled highways and 50 to 75 Phon on less traveled highways.<sup>66</sup> Ambient noise levels below 90 Phon affect sleep, concentration, and performance, while levels exceeding 90 Phon can cause adverse physiological effects, such as deafness.<sup>67</sup> Projections in 1971 indicated

---

60. No specific measure to interrupt the flow of through traffic in residential areas was mentioned. Prohibitions against parking and stopping were the only measures mentioned to improve the flow of through traffic on major highways. *Id.* at 19.

61. Stadtentwicklungsreferat. The Office of City Development was assisted by various city and state agencies. The 1971 Report notes that the Kreisverwaltungsreferat (Office of Municipal Administration), the Studiengruppe für Biologie und Umwelt (Biological and Environmental Research Team), and the Bayerische Staatliche Prüfamnt für Technische Physik (Bavarian State Testing Office for Applied Physics) were of particular assistance in preparing the 1971 Report. *Id.* at 4.

62. The 1971 Report also examined the issues raised by eleven proposals or reports issued as early as 1969. Three of the proposals dealt with noise. Proposal No. 93 was introduced by the GDP faction in the City Council on Oct. 23, 1969, proposing a noise commission for the Munich-Riem airport. Proposal No. 189 was introduced by the SPD faction in the City Council on Mar. 10, 1970, proposing a reduction of aircraft noise in the Munich region. Proposal No. 234 was introduced by the SPD faction in the City Council on Oct. 20, 1970, as a means for controlling urban noise. *Id.* at 21-23.

63. *Id.* at 5.

64. *Id.* at 42.

65. *Id.* at 41.

66. *Id.*

67. *Id.* at 42. This information correlates closely with the information found in the *Ambient Noise Levels Document*. See Section II, notes 14-17 and accompanying text *supra*.



that traffic in Munich would increase by fifty-five percent by 1985. This increase would add 1 to 2 dB(A) to the ambient noise level, a fifty percent increase over the 1971 levels. A decrease in the speed of traffic flow would add an additional 4 dB(A) to the ambient noise level.<sup>68</sup> Timely abatement measures were deemed to be the only solution to the problem.

The 1971 Report acknowledged that "measurements of noise impact in Munich [were] incomplete."<sup>69</sup> Neither complete measurements nor a "noise map" based on traffic flow existed for Munich. The authors contended, however, that complete measurements and/or a noise map would not have added any additional understanding to the noise problem.<sup>70</sup>

Chapter 9 of the 1971 Report, entitled "Measures for a More Effective Protection of the Environment in Munich," proposed several measures for combating noise pollution in Munich.<sup>71</sup> Section 9.0 called for strict control based on existing laws.<sup>72</sup> Two measures were proposed. Measure 1 called for an increase in the number and quality of enforcement personnel, specifications as to what actions should be taken and in what sequence, ascertainment of the necessary costs, and the closing of the most serious loopholes in existing laws.<sup>73</sup> The 1971 Report indicated that this measure lay within the competence of local government and assigned it "immediate" priority.<sup>74</sup> Measure 2 called for an increase in the severity of the sentences meted out to offenders.<sup>75</sup> The

68. 1971 REPORT, *supra* note 1, at 42.

69. *Id.* at 32.

70. *Id.*

71. Massnahmen zu einem wirkungsvolleren Schutz der Umwelt in München, 1971 REPORT, *supra* note 1, at 57. Neither time, existing knowledge, nor the available personnel were sufficient to permit the working group to carefully analyze all of its proposals. Consequently, it recommended that each of the proposals be evaluated in terms of the following five considerations:

- (1) What amendments to existing laws will be necessary?
- (2) Within whose competence does the measure lie?
- (3) What will the public and private costs be?
- (4) Whose interests will be affected?
- (5) How will the implementation of these measures affect other measures?

*Id.*

72. There was general agreement that existing laws were not enforced as rigorously as they could be. A lack of adequately trained personnel was viewed as the most serious problem. *Id.*

73. *Id.* at 58.

74. All measures were assigned a competency and a priority. As far as competency is concerned, measures were either exclusive or concurrent. Measures were assigned short-term, mid-term, or long-term priority.

75. 1971 REPORT, *supra* note 1, at 58.

report indicated that this measure involved concurrent powers and assigned it immediate priority.

Section 9.41 described measures to abate air pollution caused by motor vehicles;<sup>76</sup> several of these measures would affect noise emissions either directly or indirectly. Measure 1 called for strict and effective control of parking and stopping prohibitions.<sup>77</sup> Measure 2 recommended that the number of motor vehicles near areas closed to traffic be reduced by means of traffic limitations and/or one-way streets.<sup>78</sup> Measure 4 called for express buses and streetcars.<sup>79</sup> Measure 5 recommended an increase in the number of areas closed to traffic.<sup>80</sup> Measures 6 and 7 called for changes in the taxation of motor vehicles and in the tax concession for business travel by motor vehicles.<sup>81</sup> Measure 11 recommended stricter control of motor vehicle emissions.<sup>82</sup> With the exception of measures 6 and 7, which lay within the competence of the federal government, all of the measures lay within the competence of local government. All of the measures, except measure 5, which was assigned a "near future" priority, were assigned an immediate priority.

Section 9.51 covered noise reduction. Measure 1 called for a reduction of motor vehicle noise emissions, particularly in the case of motorcycles and trucks.<sup>83</sup> The report indicated that this measure lay within the competence of the federal government and assigned it immediate priority. Measures 2 and 4 recommended the closing of all streets in residential areas between 10:00 p.m. and 6:00 a.m.

---

76. *Massnahmen zur Verringerung der Luftverunreinigung. Id.* at 69.

77. *Id.* Such prohibitions curtail the use of motor vehicles and encourage the use of public transportation.

78. *Id.* at 69-70. Since the problem of noise is not confined to the inner city, action must be taken to discourage the use of motor vehicles surrounding the inner city.

79. *Id.* at 70. Express buses and streetcars make public transportation more attractive.

80. *Id.* at 71. Marienplatz, the central square in Munich, and adjacent areas have been closed to traffic since 1972. This action has been enthusiastically received by the people of Munich.

81. *Id.* at 71-72. Measure 6 recommended that motor vehicles be taxed on the basis of horsepower rather than displacement. The 1971 *Report* recommended that this tax take the form of a gasoline tax. The higher the octane rating, the higher the tax. The revenues derived from this tax could then be used for environmental purposes. The working group took the position that the tax concession should be abolished or individuals who use other forms of transportation should be granted the same tax concession that motor vehicle drivers now enjoy.

82. *Id.* at 73-74. The working group concluded that tests needed to be conducted more frequently than every other year. They recommended that TÜV and ADAC (the German Automobile Club) provide free testing stations. *Id.* at 74.

83. *Id.* at 85. If the 1971 noise emission standards remained unchanged, and the level of traffic increased as expected, noise would be 50% more disturbing in 1980 than in 1971.

Other streets<sup>84</sup> would be closed to truck and motorcycle traffic during these same hours.<sup>85</sup> The *1971 Report* indicated that these measures lay within the competence of local government and assigned them immediate priority. Measure 3 called for strict compliance with noise emission standards and heavy penalties for those drivers whose motor vehicles exceeded such standards.<sup>86</sup> The report indicated that this measure lay within the competence of local government and assigned it immediate priority. Measure 5 recommended a continuation of the program to cover cobblestone streets with an asphalt surface. The report indicated that this measure was within the competence of local government and assigned it immediate priority.

Section 9.54 covered noise abatement. Measure 1 called for much greater attention to noise abatement techniques during construction of new through highways and streets that would be heavily traveled than had been given in the past.<sup>87</sup> The *1971 Report* indicated that all three levels of government shared responsibility for implementing this measure and assigned it near future priority. Measure 2 recommended that building techniques be developed and reviewed with the noise problem in mind.<sup>88</sup> The *1971 Report* indicated that this measure lay within the competence of local government and assigned it near future priority. Measure 3 called for the use of noise-absorbent materials and procedures.<sup>89</sup> The *1971 Report* indicated that this measure lay within the competence of local government and assigned it near future priority.

## 6. *The 1974 Report*

On November 27, 1973, the Social Democratic Party presented Proposal No. 297 before the City Council. Proposal No. 297 contained three points:

- (1) The City Council appealed to the Federal Republic and the State of Bavaria to immediately undertake a program to install noiseproof windows in buildings on streets subject to severe disturbance and to provide the necessary funds for this program;

---

84. Major thoroughfares and streets in industrial and business districts would be excepted from the driving curfew during evening hours. *Id.* at 86.

85. *Id.*

86. *Id.*

87. *Id.* at 91.

88. *Id.*

89. *Id.* at 92. The working group freely acknowledged that cost rather than availability was the stumbling block for using noise-absorbent materials and procedures.

- (2) in this connection, the mayor was authorized to present concrete proposals to the Federal Republic and the State of Bavaria; these proposals called for the owner of the building to bear approximately fifty percent of the cost of the program; and
- (3) the City Finance Department was authorized to make DM 500,000 available for this program; however, this action was not to be construed as imposing a legal responsibility on the city.<sup>90</sup>

In response to this proposal, the City Council authorized the Building Department<sup>91</sup> and the City Finance Department<sup>92</sup> to prepare and submit a detailed program to the City Council. This program was submitted in a report — Installation of Noiseproof Windows (the 1974 Report) — which had as its premise the concentration of efforts in areas where noise problems were most severe.<sup>93</sup>

According to the 1974 Report, “protection of the people from unreasonable and harmful noise is one of the most important responsibilities of the city in the area of environmental protection.”<sup>94</sup> The 1974 Report concluded that “existing measures have been unable to cope with the noise problem.”<sup>95</sup> In support of this conclusion, the 1974 Report contrasted recommended and actual ambient noise levels. Table VII-2<sup>96</sup> summarizes the ambient noise levels recommended by DIN 18005.<sup>97</sup>

---

90. 1974 Report, *supra* note 2, at 1.

91. Baureferat.

92. Standtkämmerei.

93. 1974 Report, *supra* note 2, at 2.

94. *Id.*

95. *Id.* at 5.

96. Table VII-2 is based on information found in the 1974 Report, *supra* note 2, at 3.

97. For a discussion of DIN 18005, see Section V, notes 529-31 and accompanying text *supra*. The German Norms Commission (Deutscher Normenausschuss (DNA)) is not the only entity recommending that certain ambient noise levels should be observed. For example, a Sept. 15, 1969, resolution of the Bavarian Ministry of the Interior contained the following provision: “An attempt should be made to coordinate present and future traffic with industrial plants and areas of construction so as to protect citizens from the unnecessary effects of traffic, e.g., disturbance through noise, air pollution . . . and vibration.” 1974 Report, *supra* note 2, at 3.

TABLE VII-2

Area	Ambient Noise Level	
	Day	Night
	(in dB (A))	
Purely residential area	50	35
Generally residential area	55	40
Mixed area	60	45
Business area	65	50
Industrial area	70	70

Table VII-3<sup>98</sup> describes ambient noise levels along four major thoroughfares in Munich.

TABLE VII-3

Street	Ambient Noise Level (in dB (A))
Richard Strauss Street	84
Trappentreu Street	83
Brudermühl Street	81
Landshuter Avenue	79

The disparity between actual and recommended ambient noise levels was so great that an increasing number of citizens were complaining about the situation. Unfortunately, noted the report, the gap between recommended and actual ambient noise levels cannot be bridged, since DIN 18005 ambient noise levels can only be achieved in sufficiently large, free areas where the price of land is no consideration.<sup>99</sup> These conditions are not likely to occur with any degree of regularity within urban areas like Munich.<sup>100</sup> Indeed, these conditions are so rare in the Federal Republic of Germany that the withdrawal of DIN 18005 and its

98. Table VII-3 is based on information found in the 1974 Report, *supra* note 2, at 4.  
99. *Id.*

100. According to the 1974 Report, the noise levels recommended by DIN 18005 are and will be the exception rather than the rule in urban areas. *Id.*

replacement with a more realistic standard has been recommended.<sup>101</sup>

Since existing measures have been unable to cope with the noise problem, and since traffic noise is the major source of noise in Munich, the 1974 Report suggested that Munich proceed on two fronts. First, Munich should explore measures that either curtail or moderate noise from motor vehicles, provided those measures are within its capabilities. Second, Munich should propose legislation to the federal government and the government of Bavaria.

The most effective measures for controlling traffic noise are those taken at the source. Because of the pervasiveness of federal and state regulation of traffic noise, local government has very little to say about such measures. The 1974 Report did recommend that Munich exert whatever influence it had to correct several problematic situations. One such situation, described as incomprehensible, allowed automobile manufacturers to produce vehicles with one set of environmental specifications for export and another less stringent set of environmental specifications for use within the Federal Republic of Germany.<sup>102</sup> Another problem was the failure to subject existing noise emission standards to rigorous and continuous review in order to ensure they were consistent with best available technology.<sup>103</sup>

Since Munich's influence was minimal in the area of noise reduction at the source, the 1974 Report recommended that three protective measures receive concentrated attention: lowering speed limits, replacing "noisy" street surfaces, and installing noiseproof windows. Speed limit information was available from several sources. According to the Federal Institute for Highways,<sup>104</sup> the most desirable speed from the standpoint of noise emissions was 70-80 kmph/43-50 mph for automobiles and 40-60 kmph/25-37 mph for trucks.<sup>105</sup> An environmental report of the Bavarian State Ministry for Land Development and the Environment,<sup>106</sup> published in 1972, concluded that the most desirable

---

101. The recommendation that DIN 18005 be withdrawn was made by the Bauausschuss des Deutschen Städtetags (Building Committee of the German Council of Cities). *Id.*

102. *Id.* at 5.

103. *Id.*

104. Bundesanstalt für Strassenwesen.

105. 1974 Report, *supra* note 2, at 7.

106. Bayerisches Staatsministerium für Landesentwicklung und Umweltfragen.

speed was 40-60 kmph/25-37 mph.<sup>107</sup> The Bavarian TÜV conducted tests on a highway near Erlangen and concluded that the noise level decreased by one-third when the speed of the motor vehicle was reduced from 100 kmph/62 mph to 70 kmph/43 mph.<sup>108</sup> In order to determine what effect lowering the speed limit from 80 kmph/50 mph to 60 kmph/37 mph would have, tests were being jointly conducted by Bavaria and Munich at the time the 1974 Report was being prepared.<sup>109</sup>

The report also recommended that approximately 2.9 million square meters /31.3 million square feet<sup>110</sup> of "noisy" street surface in Munich needed to be replaced by "quiet" street surface.<sup>111</sup> The cost of replacing this amount of street surface was estimated to be DM 28,000,000.<sup>112</sup> Under the program recommended by the 1974 Report, 100,000 square meters/1,080,000 square feet would be replaced each year at a yearly cost of DM 4,000,000.<sup>113</sup>

Although the proposals to lower speed limits and replace noisy street surfaces were viewed as important, the third proposal, calling for the installation of noiseproof windows, was viewed as the most important. There are two varieties of noiseproof windows—one type with and the other without an air space between two panes of glass.<sup>114</sup> Such windows are capable of reducing the noise level by 30 to 50 dB(A).<sup>115</sup>

A program to install noiseproof windows raised questions of authority and cost. One question was whether local governments like Munich had the authority either to induce or to coerce an owner to install noiseproof windows. After reviewing the existing laws, the only conclusion the 1974 Report could reach was that the answer to this question was inconclusive.<sup>116</sup> Munich might

107. 1974 Report, *supra* note 2, at 7.

108. *Id.*

109. *Id.* at 7-8. The tests were being conducted on a portion of Errner Street, a heavily traveled highway, between the city limits and Johanneskirchner Street.

110. One square meter (m<sup>2</sup>) equals 10.8 square feet (ft<sup>2</sup>).

111. 1974 Report, *supra* note 2, at 8. (The 1974 Report estimated that 700,000 m<sup>2</sup>/7.6 million ft<sup>2</sup> required "immediate" attention.)

112. *Id.* DM 28,000,000 is equivalent to approximately \$14,000,000.

113. *Id.*

114. *Id.* at 11.

115. *Id.* at 8.

116. The 1974 Report examined four different laws and found none completely satisfactory.

(1) Section 21 of the Städtebauförderungsgesetz (Law to Promote Municipal Building Codes) authorizes contributions by government to modernization projects, provided the action to be taken is part of a comprehensive project. *Id.* at 8. The working group doubted that the installation of noiseproof windows qualified as a comprehensive project. The 1974 Report cited a commentary that interpreted § 21 as authorizing contributions

have had such authority under article 78(4) of the Bavarian Building Ordinance,<sup>117</sup> provided the noise disturbance was unusually serious.<sup>118</sup> Since the authority of local governments to compel installation of noiseproof windows was doubtful, the 1974 Report recommended that Munich, pursuant to section 21 of the Law to Promote Municipal Building Codes,<sup>119</sup> seek a grant of such authority to local governments in the Federal Building Law.<sup>120</sup>

The second question posed by a program to install noiseproof windows is who should pay the costs associated with their installation. If noiseproof windows were installed either under article 78(4) of the Bavarian Building Regulations or pursuant to a grant of authority in the Federal Building Law, the owner would have to pay for their installation and could pass this cost on to his tenants.<sup>121</sup> Noiseproof windows are prohibitively expensive: windows with an air space cost approximately DM 1700 per square meter; windows without an air space cost between DM 500 and DM 1000 per square meter.<sup>122</sup> Accordingly, the 1974 Report concluded that government has a moral as opposed to a legal responsibility to help those individuals whose health or well-being is

---

for the installation of noiseproof windows only if that action was taken in conjunction with a comprehensive modernization project. *Id.* at 9 (citing BIELENBERG, KOMMENTAR, STÄDTEBAUFÖRDERUNGSGESETZ § 1 (1973) (Commentary to the Law to Promote Municipal Building Codes)).

(2) Section 17(4) of the Bundesfernstrassengesetz (Federal Highway Law) is restricted to new construction or significant changes in existing federal highways. *Id.* In addition, there was some question as to whether noiseproof windows qualified as a highway project. Most of the decisions and commentaries held that noiseproof windows were not highway projects.

(3) Sections 41 and 42 of the Bundes-Immissionsschutzgesetz (Federal Ambient Levels Protection Law) cover noiseproof windows. *Id.* However, these provisions are restricted to new construction or significant changes in existing highways. Another problem with §§ 41 and 42 was that the necessary implementing regulations had not been issued.

(4) Article 78(4) of the Bayerische Bauordnung (Bavarian Building Ordinance) permits corrective measures on existing buildings when these measures are necessary to prevent harm to life and health. *Id.* at 10. Experts whom the working group consulted were of the opinion that this provision was restricted to unusually serious cases.

117. Bayerische Bauordnung. See note 116 *supra*.

118. 1974 Report, *supra* note 2, at 10.

119. Städtebauförderungsgesetz. See note 116 *supra*.

120. Bundesbaugesetz. The 1974 Report indicates that efforts to obtain such a grant of authority have already been undertaken. 1974 Report, *supra* note 2, at 10.

121. In the context of corrective measures on existing buildings under art. 78(4) of the Bavarian Building Ordinance, the Building Department had already expressed the opinion that the cost of measures not anticipated by the landlord could be passed on directly to his tenants. *Id.*

122. *Id.* at 11. DM 1700 per m<sup>2</sup> is equivalent to approximately \$850 for every 10.8 ft<sup>2</sup> or \$78.70 per ft<sup>2</sup>. DM 500 to DM 1000 per m<sup>2</sup> is equivalent to approximately \$250 to \$500 for every 10.8 ft<sup>2</sup> or \$23.15 to \$46.30 per ft<sup>2</sup>.



threatened by noise to pay the cost of installing noiseproof windows. The program proposed by the 1974 Report called for the government and the owners to share the costs of such installation.<sup>123</sup>

Proposal No. 297, the proposal that triggered the 1974 Report, called for Munich to make DM 500,000 available for a program to install noiseproof windows. After some initial misgivings,<sup>124</sup> Bavaria indicated its willingness to match Munich's contribution.<sup>125</sup> These amounts were sufficient to install approximately 2000 windows.<sup>126</sup> "Such a beginning would be a good beginning and would show the people of Munich that their City was earnest in its desire to improve the environmental quality of the City."<sup>127</sup>

Table VII-4<sup>128</sup> contains an estimate of what this program would cost if noiseproof windows were installed in buildings on three of the principal thoroughfares in Munich.

TABLE VII-4

Street	Estimated Cost
Mittlerer Ring	approx. DM 14 to 24 million
B 12	approx. DM 1 to 2 million
Fürstenrieder Street	approx. DM 3.5 to 6 million

Since the cost of the program was so great, the 1974 Report acknowledged the necessity of an incremental approach and recommended that the first steps be taken as soon as possible.

123. *Id.* at 12.

124. In response to a proposal by a group of citizens, the Bavarian Ministry for the Interior indicated on Aug. 29, 1973, that Bavaria had no funds available to use in installing noiseproof windows. *Id.* at 11.

125. *Id.* at 13. On Mar. 21, 1974, the Bavarian State Minister for Land Development and Environment wrote the mayor of Munich with respect to a program to install noiseproof windows. He stated that Bavaria considered the use of state resources in such a program "reasonable" and "necessary." *Id.* at 12. The first meetings between city and state officials were held at the time the 1974 Report was being written. The purpose of these meetings was to determine the contribution of each level of government and to prepare a list of projects, ranked in order of priority.

126. Bavaria and Munich each planned to contribute DM 500,000, and owners were expected to match their contributions by contributing DM 1,000,000. If the average cost of a noiseproof window is DM 1000, DM 2,000,000 will permit the installation of 2000 windows.

127. 1974 Report, *supra* note 2, at 13.

128. Table VII-4 is based on information found in the 1974 Report, *supra* note 2, at 14.

### 7. *The 1977 Report*

During the time the 1974 Report was being drafted, representatives from Munich and the Bavarian State Ministry for Land Development and the Environment<sup>129</sup> were meeting to determine the contribution of each level of government to a program to install noiseproof windows and to draw up a list of projects, ranked in order of their priority. The result of these meetings, described in a report—Addendum to the Report on Installing Noiseproof Windows in Existing Dwellings Along Heavily Traveled Streets; Action Plan for 1975-1977 (the 1977 Report)<sup>130</sup>—was an “Action Plan” which called for Munich and Bavaria to each contribute DM 500,000.<sup>131</sup> Owners were expected to match these amounts by contributing DM 1,000,000.<sup>132</sup>

In determining priorities, the representatives from Munich and Bavaria agreed that no funds should be made available to install noiseproof windows unless the ambient noise level was at least 77 dB(A). They also agreed that the Action Plan should begin with dwellings located in areas where the ambient noise level was at least 80 dB(A).<sup>133</sup> Munich’s City Council approved the Action Plan on February 5, 1975.<sup>134</sup>

Table VII-5<sup>135</sup> outlines the expenditures made or to be made between 1975 and 1977 under the Action Plan.

---

129. Bayerisches Staatsministerium für Landesentwicklung und Umweltfragen.

130. Baureferat, Zuschüsse zum Einbau von Schallschutzfenstern in bestehenden Wohnbauten an besonders verkehrsreichen Strassen; Förderungsprogramme 1975-1977 (Addendum to the Report on Installing Noiseproof Windows in Existing Dwellings Along Heavily Traveled Streets; Action Plan for 1975-1977) (Dec. 8, 1977) [hereinafter cited as 1977 Report].

131. *Id.* at 1-2.

132. *Id.* at 2.

133. *Id.* at 3.

134. *Id.* at 1.

135. Table VII-5 is based on information found in the 1977 Report, *supra* note 130, at 2.

TABLE VII-5

Year	Expenditures (thousands of DM)			
	Bavaria	Munich	Owners	Total
1975 <sup>136</sup>	500	500	1,000	2,000
1976 <sup>137</sup>	500	500	1,000	2,000
1977				
Phase I <sup>138</sup>	500	500	1,000	2,000
Phase II <sup>139</sup>	1,000	1,000	2,000	4,000
Phase III <sup>140</sup>	500	500	1,000	2,000
TOTAL	3,000	3,000	6,000	12,000

Table VII-6<sup>141</sup> summarizes the achievements of the program as of November 24, 1977.

TABLE VII-6

Year	Windows/Doors	Apartments	Dwellings
1975	1,421	587	55
1976	1,312	559	57
1977/I	1,510	565 <sup>142</sup>	69
TOTAL	4,243	1,711	181

136. During 1975 the aim of the Action Plan was to install noiseproof windows in 93 dwellings along 12 streets in Munich. *See id.* at 3-4. Thirty-four owners declined to participate in the program by contributing matching funds. According to the 1977 Report, the three most common reasons given by owners for their failure to participate were (1) the amount of the contribution expected of them, (2) the fact that the dwelling could not be renovated due to age, and (3) difficulties with tenants. *Id.* at 6.

137. During 1976 the aim of the Action Plan was to install noiseproof windows in 165 dwellings along 24 streets in Munich. *See id.* at 4. One hundred owners declined to participate in the program by contributing matching funds. *Id.* at 3, 5.

138. During 1977/I the aim of the Action Plan was to install noiseproof windows in 156 dwellings along 17 streets in Munich. *See id.* at 5. Ninety-nine owners declined to participate in the program by contributing matching funds. *Id.* at 3, 5.

139. During 1977/II the aim of the Action Plan was to install noiseproof windows in 82 dwellings along 23 streets in Munich. *See id.* at 5-6. 1977/II had not been completed by the time the 1977 Report was written. *Id.* at 2. DM 1,458,960 of the DM 2,000,000 Bavaria and Munich had agreed to contribute was available for use.

140. 1977/III had not yet been undertaken when the 1977 Report was written. *See id.* at 2.

141. Table VII-6 is based on a table in the 1977 Report, *supra* note 130, at 2.

142. The number of affected apartments for 1977/I is an approximation. *See id.*

Since the number of people in dwellings or apartments depends on size and floor space use, the exact number of people affected by the program to install noiseproof windows is unknown. The 1977 Report indicated that a figure of two to three people per apartment would be reasonable.<sup>143</sup> Using this figure, Table VII-7<sup>144</sup> shows that nearly 4000 individuals were affected by the program to install noiseproof windows during the first three years of its existence.

TABLE VII-7

Year	Number of People Affected
1975	1,350
1976	1,286
1977/I	<u>1,300</u>
TOTAL	3,936

According to the 1977 Report, the overwhelming majority of those who participated in the program to install noiseproof windows expressed themselves as "very satisfied" with its results.<sup>145</sup> Only a small majority expressed any dissatisfaction, and their dissatisfaction usually was prompted by improper installation of the windows.<sup>146</sup>

The 1977 Report, therefore, concluded that the program to install noiseproof windows was beneficial and should be continued. It further recommended that approximately DM 4,000,000<sup>147</sup> be spent on the program annually and that renewed efforts be made to involve the federal government in the program.<sup>148</sup>

---

143. *Id.*

144. Table VII-7 is based on information found in the 1977 Report, *supra* note 130, at 3.

145. *Id.* at 6.

146. *Id.*

147. The DM 4,000,000 figure is made up of the following contributions:

Munich	DM 1,000,000
Bavaria	DM 1,000,000
Owners	DM 2,000,000

*Id.* at 7.

148. *Id.* Both Munich and Bavaria had made earlier attempts to interest the federal government in the program to install noiseproof windows. These attempts had been rebuffed. On Oct. 13, 1977, Munich's Oberbürgermeister (mayor) was authorized to renew the attempt to interest the federal government in the program to install noiseproof windows. The success or failure of this attempt was unknown at the time the 1977 Report was written. It was ultimately acknowledged that the renewed attempt was a failure. See 1978 Letter, *supra* note 1, at 2.



## SECTION VIII

### CONCLUSION

In the preceding seven Sections, the problem posed by traffic noise and the American and German responses to that problem at the federal, state, and local level have been described and analyzed in considerable detail. Those details lay the groundwork for this concluding Section, which has two purposes. First, this Section notes some of the deficiencies in the existing regulatory scheme and proposes corrective action that could be taken. Second, this Section outlines an enforcement strategy for state and local governments in the United States, since they will be called upon to bear the brunt of the enforcement responsibility under the emerging division of responsibilities.

#### *A. Deficiencies in Existing Regulatory Schemes*

Source modification is the noise abatement technique that has received the greatest priority both in the United States and the Federal Republic of Germany. Both countries have utilized federal noise emission standards as the mechanism to implement this technique.

American regulators have taken what can only be described as a cautious approach to abating traffic noise by means of federal noise emission standards.<sup>1</sup> The immediate imposition of federal noise emission standards on automobiles was rejected in 1975 as "impossible" because of "[t]he size and complexity of the automobile industry and the extensive effort necessary to adequately evaluate cost and available technology."<sup>2</sup> No one disputes the size and complexity of the automobile industry or underestimates the factors of cost and technology, but the impossibility of such a step is open to question, particularly when one realizes that many of the American manufacturers produce automobiles in the Federal Republic of Germany and have been required to meet either German or European Economic Community (EEC) noise emission standards for a number of years.<sup>3</sup>

---

1. In the American regulatory scheme, federal noise emission standards are performance standards and are based primarily on public health and welfare and secondarily on "best available technology" and "cost of compliance." Noise Control Act of 1972 § 6, 42 U.S.C. § 4905(c)(1) (1976).

2. 40 Fed. Reg. 23,105-07 (1975).

3. The two largest American automobile manufacturers, General Motors and Ford, produce automobiles in the Federal Republic of Germany.

Apparently, German manufacturers produce motor vehicles with one set of environ-

American noise emission standards cover only medium and heavy-duty trucks and make a distinction between new and in-use trucks. New medium and heavy-duty trucks are subject to progressively lower federal noise emission standards over a seven-year period beginning on January 1, 1978, and ending on January 1, 1985. In contrast to the progressive treatment accorded new medium and heavy-duty trucks, all in-use medium and heavy-duty trucks are subject to fixed federal noise emission standards, which vary only in terms of the type of test used to measure noise emissions and the speed at which the truck is traveling.

German and EEC noise emission standards cover most types of motor vehicles and draw no distinction between new and in-use motor vehicles. Fixed noise emission standards under the EEC Directive "on the approximation of the laws of the Member States relating to the permissible sound level and the exhaust system of motor vehicles" (EEC Noise Emission Directive) are subject to modification as technical progress requires. Proposed modifications are initially referred to an adaptation committee. If the adaptation committee acts favorably on the proposed modification within a specified time, the proposed modification is referred to the Commission of the European Communities (Commission) for its approval. A proposed modification on which there is either no action or unfavorable action by the adaptation committee dies unless the Commission proposes its adoption to the Council of the European Communities (Council). Favorable action by the Council or failure to act within a three-month period permits the Commission to adopt the proposed modification.

Neither the United States, the Federal Republic of Germany, nor the EEC has chosen to adopt noise emission standards expressed in terms of unnecessary noise. All have chosen noise emission standards expressed in terms of dB(A). The approach selected by the United States for in-use medium and heavy-duty trucks and the approach selected by the Federal Republic of Germany and EEC for all motor vehicles provide for fixed noise emission standards. The EEC Noise Emission Directive couples fixed noise emission standards with a review board that periodically reviews the existing noise emission standards to determine if they

---

mental specifications for export and a less stringent set for use within the Federal Republic of Germany. The working group that prepared a Munich Report, *Installation of Noiseproof Windows* (1974 Report), described such a system as "incomprehensible." *Referat für Kreisverwaltung und öffentliche Ordnung, Einbau schalldämmender Fenster* (Installation of Noiseproof Windows) 5 (May 14, 1974) (Antrag Nr. 297 der Stadtratsfraktion der SPD vom 27. November (1973)) [hereinafter cited as 1974 Report].

comport with the best available technology. Another approach selected by the United States for new medium and heavy-duty trucks provides for progressively lower noise emission standards. There are strengths and weaknesses in both approaches.

Fixed noise emission standards have the advantage of putting manufacturers on notice as to permissible noise emission levels. There are, however, several disadvantages associated with this approach. Regulators have two options, but neither is entirely satisfactory. They can choose a noise emission level that is currently achievable in terms of technology and cost. This choice dictates less demanding noise emission standards. Alternatively, they can choose a more demanding noise emission level that is not achievable in terms of existing technology or reasonable cost. This choice necessitates delayed implementation until the technology or cost problems have been solved. Regulators must also overcome their own inertia and the interests of the manufacturers when they propose revisions of fixed noise emission standards. The German and EEC experience suggests that the twin obstacles of inertia and manufacturer interest can prove rather formidable.<sup>4</sup>

Progressively lower noise emission standards have the advantage of putting manufacturers on notice as to permissible noise emission levels and allowing them the "lead time" required to meet the permissible levels. Lead time already is and will increasingly become a significant factor because further reductions in noise emissions will increasingly involve major source modifications. For example, the United States Environmental Protection Agency (EPA) estimated in its *Background Document for Proposed Medium and Heavy Truck Noise Regulations* that the lead time for an 83 dB(A) truck with a quiet diesel engine was one to two years whereas the lead time for a 75 dB(A) truck was eight

---

4. Inertia and manufacturer interest, however, are not insurmountable obstacles. For example, the Federal Republic of Germany reduced its fixed noise emission standards on four separate occasions during a 10-year period. Referat für Kreisverwaltung und öffentliche Ordnung, Übersicht über den Stand und die Möglichkeiten der Lärmbekämpfung (Overview of the Noise Control Situation and the Possibilities for Noise Control) 9 (1968). They do result in delay. The EEC Noise Emission Directive is a case in point. France and the United Kingdom raised the question of a downward revision in the EEC Noise Emission Directive in 1973. The Commission of the European Communities acknowledged in 1974 that "a reduction of approximately three decibels . . . [is possible], without any major modification in . . . design." Answer to Written Question No. 411/73 from Mr. Müller and Mr. Kater to the Commission of the European Communities (Jan. 4, 1974) (copy in author's possession). In spite of this fact, the EEC Noise Emission Directive was not amended until Feb. 21, 1977.



years.<sup>5</sup> Noise emission levels below 75 dB(A) will be even more difficult to achieve and may require even greater lead time. The disadvantage of progressively lower noise emission standards is that they are even more difficult to revise than fixed noise emission standards. Regulators and manufacturers tend to focus on the fact that noise emission standards for a particular period are lower than noise emission standards for a preceding period and are thereby lulled into a false sense of achievement. Noise emission standards are lower today than yesterday and will be lower still tomorrow. This kind of thinking obscures the real issue, which is whether the noise emission standards for any particular period are the best available given the constraints of existing technology and reasonable cost.

Both approaches to noise emission standards have their advantages, but a hybrid approach may be more advantageous than either of them. This hybrid approach contains two elements: progressively lower noise emission standards, coupled with a review board. This approach incorporates the notice and lead time advantages of the progressively lower noise emission standards approach and avoids the disadvantages of less demanding noise emission standards or delay which are inherent in the fixed noise emission standards approach. In addition, this hybrid approach deals directly with the problem of revising existing noise emission standards by coupling the progressively lower noise emission standards with a review board whose function is to periodically examine existing noise emission standards to determine if they require adjustment in light of best available technology.

The composition of the review board is critical to its success in performing its function. Noise regulation is, or at least should be, an interdisciplinary matter. The review board, therefore, should have legal, medical, and economic representatives, as well as technical representatives. Conceivably, all these representatives could be drawn from either the regulators or the manufacturers. This result would be undesirable. Representatives of the regulators and the manufacturers should sit on the review board, but they should constitute a minority. Their role should be to provide general expertise and practical insights into the effects, economic and otherwise, that a downward revision in the progressively lower noise emission standards would have. Neither group should be in a position to dictate the review board's decision. To

---

5. U.S. ENVIRONMENTAL PROTECTION AGENCY, DOC. NO. 550/9-74-018, BACKGROUND DOCUMENT FOR PROPOSED MEDIUM AND HEAVY TRUCK NOISE REGULATIONS 8-22 (1974).

allow otherwise would cause the review board to become captive to the interests of either the regulators or the manufacturers, and the credibility of its decisions would be seriously undermined. The review board's decisions must be credible. They ought to be independently derived and objective in nature. If they are, they may not please either the regulators or the manufacturers, but they will survive public and, possibly, judicial scrutiny.

Even if the deficiencies associated with new motor vehicles were rectified by adopting the proposed hybrid approach, deficiencies associated with in-use motor vehicles would still remain. Some of these deficiencies are rather graphically illustrated by the New Truck Regulations, which apply to new medium and heavy-duty trucks in the United States.

Subpart B of the New Truck Regulations contains so-called "useful life" provisions. One such provision requires a warranty by the manufacturer to the first retail purchaser and each subsequent purchaser that the "motor vehicle was designed, built, and equipped at the time of sale to the first retail purchaser to conform with all applicable [EPA] noise control regulations."<sup>6</sup> The limited nature of this manufacturer's warranty needs to be emphasized. A manufacturer warrants only that the new medium or heavy-duty truck complies with the applicable noise emission standards *at the time of sale* to the first retail purchaser. He makes no warranty with respect to compliance at any time subsequent to the time of sale to the first retail purchaser.

Another "useful life" provision requires instructions as to proper maintenance, use, and repair of motor vehicles. These instructions are to inform purchasers and mechanics of the actions that are necessary to assure that the vehicle will conform to the applicable noise emission standards throughout its useful life. The obvious assumption behind the New Truck Regulations is that new trucks will continue to comply with applicable noise emission standards throughout their useful lives if properly maintained, used, and repaired. If they fail to comply, either the owner or the mechanic who services the truck is responsible for noncompliance.

This assumption is open to question because the aging process itself affects the noise emission level of motor vehicles. For example, automobiles more than two years old tend to produce noise emission levels 2 to 3 dB(A) higher than new models. The significance of this statistic is underscored when one realizes that

---

6. 40 C.F.R. § 205.58-1(a) (1978).

seventy percent of the automobiles being operated in the United States in 1970 were at least three years old.<sup>7</sup> Improper maintenance, use, or repair certainly contributes to the aging process. The question, however, is whether the total disparity in noise emission levels between new and in-use motor vehicles can be traced to such improper maintenance, use, or repair.

On this question, EPA itself equivocates. The New Truck Regulations, if considered in isolation, implicitly suggest that improper maintenance, use, or repair are solely responsible for the disparity. A contrary suggestion, however, results from a comparison of the New Truck Regulations and the Interstate Motor Carrier Noise Emission Regulations (Motor Carrier Regulations). Both sets of regulations apply to essentially the same type of motor vehicles: the New Truck Regulations apply to "any vehicle . . . [with a gross vehicle weight rating] in excess of 10,000 pounds . . . [and] designed for the transportation of property";<sup>8</sup> the Motor Carrier Regulations apply to "all motor vehicles or . . . motor carriers . . . [with a gross vehicle weight rating or a gross combination weight rating] in excess of 10,000 pounds."<sup>9</sup> New and in-use trucks, however, are subject to different noise emission standards. New trucks are governed by the New Truck Regulations, which establish an 83 dB(A) noise emission standard for the model years 1977-1980. In-use trucks are governed by the Motor Carrier Regulations, which establish an 86 dB(A) noise emission standard.

The regulations should be identical if proper maintenance, use, or repair is the sole source of the disparity in noise emission levels between new and in-use motor vehicles. The noise emission standards are not and probably should not be identical because maintenance, use, and repair are among, but do not constitute, an exclusive list of the "aging" factors. If this analysis is correct, the apportionment of liability between the manufacturer on the one hand and the owner or the mechanic on the other hand requires further refinement. An exhaustive list of the factors contributing to the aging process needs to be prepared. Assignment of liability would then be made on the basis of who has control over which factors.

Since in-use motor vehicles are noisier than new motor vehicles, identical noise emission standards for both types of vehicles

---

7. U.S. ENVIRONMENTAL PROTECTION AGENCY, TRANSPORTATION NOISE AND NOISE FROM EQUIPMENT POWERED BY INTERNAL COMBUSTION ENGINES 108 (1973).

8. 40 C.F.R. § 205.50 (a) (1978).

9. *Id.* § 202.12 (1978).

are not feasible. There are two approaches to this problem. One approach would be to establish independent noise emission standards for new and in-use motor vehicles. Arguably, the most strenuous in-use noise emission standards will result by adopting the independent standards approach. Each set of noise emission standards would be independently derived; the merits of each set would be independently considered. The fallacy of this argument is that both the German regulatory scheme during its infancy and the current American regulatory scheme tend to emphasize new motor vehicle noise emission standards almost to the exclusion of in-use motor vehicle noise emission standards.

An alternative approach views new and in-use motor vehicle noise emission standards as interdependent standards. If this second approach were adopted, the mechanics of its operation would require the applicable regulatory agency to make two interrelated determinations illustrated by the following hypothetical situation. The regulatory agency initially determines that "X" is the best achievable noise emission standard for two-year old motor vehicles. The regulatory agency then determines that the aging process causes a 2 dB(A) deterioration during the first two years of operation. "X" would then be established as the in-use motor vehicle noise emission standard, and "X - 2 dB(A)" would be established as the new motor vehicle noise emission standard. Arguably, interdependent standards are more strenuous than independent standards because regulators, who are preoccupied with making new motor vehicle noise emission standards as strict as possible, will be forced to establish in-use motor vehicle emission standards consistent with those strict new motor vehicle noise emission standards. Regulators, however, are not unaware of lead-time requirements, and these requirements could exercise a moderating effect on in-use motor vehicle noise emission standards as well as new motor vehicle noise emission standards if the two sets of standards were interdependent.

Regulators have shown a clear preference for the independent standards approach. This preference can be partially explained by their preoccupation with new motor vehicle noise emission standards. Establishing new motor vehicle noise emission standards is no easy task, and regulators do not want to further complicate the task by linking in-use with new motor vehicle noise emission standards.

The preference for independent standards can also be explained by several practical considerations. Noise emission standards for new motor vehicles are easy to enforce. There is no need

to test each individual motor vehicle. Selected motor vehicles can be tested by type in order to determine compliance for all motor vehicles within that type category. Such type-testing of in-use motor vehicles would be substantially more difficult if not impossible because of differences in maintenance, use, and service. In addition, noise emission standards for new vehicles permit regulators to exercise an increasing control over all motor vehicles in the entire fleet of new and in-use motor vehicles. In-use motor vehicles manufactured prior to the new motor vehicle noise emission standards wear out and are replaced by motor vehicles subject to noise emission standards. Over a period of years, the composition of the entire fleet of new and in-use motor vehicles shifts from a mixture of regulated and nonregulated motor vehicles to exclusively regulated motor vehicles.

In theoretical terms, interdependent standards have much to recommend them. New and in-use motor vehicle noise emission standards appear to be interdependent. Moreover, available studies permit regulators to predict with a fair degree of accuracy the amount of deterioration in noise emission levels that can be anticipated when the motor vehicle is put into use.

The likelihood that the regulators will forsake their preoccupation with independent noise emission standards and give serious consideration to interdependent noise emission standards is not great until some of the practical problems associated with in-use motor vehicle noise emission standards can be resolved. These problems can be grouped under two headings: (1) how to periodically monitor compliance with in-use motor vehicle noise emission standards and (2) how to supplement periodic monitoring.

The Germans have adopted a commonsense solution to the problem of monitoring compliance with in-use motor vehicle noise emission standards. German motor vehicles are inspected at regular intervals in accordance with annex VIII to the federal Motor Vehicle Approval Ordinance (StVZO). This inspection occurs every twenty-four months for automobiles for personal use and motorcycles and every twelve months for buses, ambulances, and automobiles for hire. A noise test is part of the inspection. This solution deserves careful consideration for several reasons. Safety inspections are conducted at least yearly in all of the fifty states. If a noise test were part of the safety inspection, all in-use motor vehicles in the United States could be monitored on a yearly basis to determine whether they complied with the applicable noise emission standards. Summaries of the results of these

noise tests could be made at the state or federal level and could be supplied to manufacturers. If any model of an in-use motor vehicle begins to demonstrate difficulties in complying with in-use motor vehicle noise emission standards, this difficulty could be picked up at an early stage through the yearly summaries and could be dealt with immediately. Motorists are familiar with safety inspections. Most vehicle owners have their motor vehicles inspected on a regular basis. If a noise test were added to the list of tests that are normally performed and if the time and cost of such a test added only nominally to the time and cost of existing tests, most motorists would not even notice the existence of the additional noise test.

There are, however, technical and legal difficulties associated with this solution. Several technical problems have surfaced in the Federal Republic of Germany. One such problem is the granting of exceptions such as permitting the owners of businesses whose personnel possess the requisite ability to conduct the motor vehicle inspection themselves. Based on the German experience, American regulators should carefully evaluate the question of exceptions.

Another technical problem encountered by the Germans has been a lack of adequate facilities, even though inspections are conducted by the Technical Control Associations. The problem of providing adequate facilities could be even more acute in the United States where commercial service stations usually conduct safety inspections. If testing procedures for in-use motor vehicles were similar to testing procedures for new motor vehicles outlined in the New Truck Regulations, the Motor Carrier Regulations, or the EEC Noise Emission Directive, service stations would have neither the space, the equipment, nor the personnel to conduct such noise tests. One response to this problem would be for states to set up a limited number of testing stations at various geographic locations throughout the state. Many states already have testing stations located throughout the state for purposes of testing applicants for driver's licenses. Some, if not all, of these testing stations would have the requisite space and could be supplied with the necessary equipment to test noise emissions. In all likelihood, some of the personnel already assigned to the testing station could be trained to administer the noise test required to monitor compliance by in-use motor vehicles with the applicable noise emission standard. This response would keep costs to a minimum in terms of obtaining equipment and trained personnel.

Another response to the problem posed by using the testing procedure for new motor vehicles to test in-use motor vehicles is to design a new testing procedure for in-use motor vehicles. Such a testing procedure would involve a relatively inexpensive hand-held sound meter which would give accurate readings when held close to the motor vehicle rather than at 50 feet/15.2 meters from the motor vehicle. Based on a rather limited sample, German technicians are more enthusiastic about developing and using close-range sound meters than are their American counterparts. If such a sound meter could be developed and sold at reasonable cost, a noise test could easily be incorporated into the existing structure of the safety inspection.

The legal difficulties associated with having service stations or state testing stations periodically monitoring compliance with in-use motor vehicle noise emission standards are illustrated by the laws of New York State. The Vehicle and Traffic Law of New York State has a noise emission standard, section 386, and muffler provisions for motor vehicles, section 375(31), and motorcycles, section 381(1) and (11), which prohibit excessive, unusual, or unnecessary noise. In spite of these provisions, the Department of Motor Vehicles does not require service station operators to conduct a noise test as a part of the safety inspection. This result is justified on a number of practical and legal grounds. For example, sections 375(31) and 381(1) and (11) are treated as safety rather than noise provisions. The individual conducting the safety inspection, therefore, complies with Department of Motor Vehicles requirements when he determines that the motor is equipped with a muffler. He need do no more.

Some of these legal difficulties could be eliminated if the Department of Motor Vehicles would instruct service station operators to conduct a noise test as a part of the safety inspection, but the Department of Motor Vehicles is reluctant to take this step until some of the practical problems associated with such a test are resolved. Even if these practical problems could be resolved, some legal difficulties would remain. Section 386, for example, masquerades as a motor vehicle noise emission standard but is really a truck noise emission standard. Trucks and other motor vehicles do not have the same noise characteristics. They, therefore, should not be subject to the same noise emission standard. If they are, the noise emission standard is either a truck noise emission standard, which requires too little of most other types of motor vehicles, or a motor vehicle noise emission standard, which requires too much of trucks. Section 386 is of the former rather than the latter variety.

These difficulties in New York can only be resolved by amending section 386 or adopting a new provision that contains noise emission standards for other types of motor vehicles. Since the federal government has only acted in the areas of new and in-use medium and heavy-duty trucks, New York State is free to establish whatever noise emission standards it chooses for other types of motor vehicles.

The other problem associated with in-use motor vehicle standards is how to supplement periodic monitoring. Neither the United States nor the Federal Republic of Germany has faced this problem squarely. As a result, the police have assumed more or less by default the responsibility of supplementing periodic monitoring. No one—neither American or German noise experts nor American or German police—feels that this solution is desirable. A number of reasons support this unanimous conclusion. The average police officer can deal with the unreasonable noise caused by a barking dog, but he lacks not only the equipment but also the training to determine whether an in-use motor vehicle complies with applicable noise emission standards. Training and equipping police officers to perform this assignment would be expensive and time consuming. Even if these twin obstacles could be overcome, the problem of priorities would still remain. Noise has been, still is, and probably will continue to be a low-priority item for the police. Given their other responsibilities, no one can really argue with the priority assigned to noise abatement by the police.

Under these circumstances, other options ought to be explored. One option, actually a nonoption, would be to acknowledge the inability of the police to conduct supplementary periodic monitoring of in-use motor vehicles and to conclude that supplementary periodic monitoring is unnecessary, particularly if periodic monitoring of in-use motor vehicles is being conducted on a yearly basis.

Splitting the responsibilities for supplementary periodic monitoring between the police and the individuals who conduct the periodic monitoring is another option. This approach has been adopted by the Germans in section 49 of the StVZO. Section 49 requires a motorist to have his vehicle tested at the nearest inspection station if there is reason to believe that the in-use motor vehicle does not comply with the applicable noise emission standard and if he is directed to do so by an "authorized individual."

A similar division of responsibilities between the police and



testing stations could be adopted in the United States. The police would have the responsibility of subjectively judging whether an in-use motor vehicle complies with applicable noise emission standards. If there is probable cause to believe that noncompliance exists, a police officer could issue a "notice of inspection" directing the owner or operator either to have his motor vehicle inspected at a testing station within a certain period of time, perhaps twenty days, or to submit written proof that his motor vehicle is in full compliance with the applicable in-use motor vehicle emission standard within the same period of time. The owner or operator who chooses to have his motor vehicle inspected at a testing station rather than to submit written proof of full compliance would be supplied with a copy of the test results. If the test results confirm that the in-use motor vehicle does not comply with the applicable noise emission standards, the owner or operator would be required (1) to bring his in-use motor vehicle into compliance within a stated period of time, perhaps ten days, (2) to pay a specified fine, and (3) to pay the cost of the inspection. These sanctions would discourage abuses by owners or operators. Abuse of discretion by the police could be dealt with by providing some type of pre-test hearing or, preferably, by requiring the police budget to bear the cost of inspections where a notice of inspection has been issued and the motor vehicle is found to comply with applicable noise emission standards.

A third option to the problem of supplementary periodic monitoring is the creation of a special environmental police force. New York City has adopted this approach.<sup>10</sup> If New York City's experience with this approach is illustrative of what would happen in other cities, there is reason to believe that a small group of highly trained environmental police officers can be very effective at a reasonable cost.

New York City's Bureau of Enforcement consists of approximately eighteen people, including inspectors. Each inspector successfully completes a one-week course where he divides his time between instruction and field training before he is assigned to one

---

10. New York State will also have an environmental police force when environmental conservation officers and public health engineers are appointed to the nine regional units to be established pursuant to the New York Environmental Control Law.

Munich may also be looking in this direction. It was proposed in ch. 9 of *Municipal-Policy Aspects of Environmental Protection in Munich (1971 Report)* that the number and quality of enforcement personnel be improved. LANDESHAUPTSTADT MÜNCHEN, STADTENTWICKLUNGSREFERAT, KOMMUNALPOLITISCHE ASPEKTE DES UMWELTSCHUTZES IN MÜNCHEN (the Municipal-Policy Aspects of Environmental Protection in Munich) 58 (1971) (Arbeitsberichte zur Fortschreibung des Stadtentwicklungsplans - Nr. 3).

of New York City's five boroughs. Table VIII-1 <sup>11</sup> summarizes by year the number of motor-vehicle-related citations issued by the Bureau of Enforcement from October 1972 to December 1978.

TABLE VIII-1

Category of Violation	Citations						
	Year						
	1972	1973	1974	1975	1976	1977	1978
Motor Vehicles	—	9	2,124	765	234	1	2
Sound Signal Devices/ Horn honking	—	420	200	13	1	5	4
Claxons	—	52	164	—	—	—	1
Sirens	—	—	2	—	—	—	1

The number of motor-vehicle-related citations peaked in 1974 and declined in the following years. Obviously, a portion of this decline can be attributed to New York City's financial problems, which have forced the Bureau of Enforcement to cut back on its activities. Another portion of the decline, however, can be attributed to the success of the enforcement program. Repeat offenders are rare.

### *B. The Enforcement Problem*

#### *1. Division of federal and state responsibilities*

Since the enactment of the federal Noise Control Act in 1972, a division of noise regulation responsibilities between the federal government on the one hand and state and local government on the other hand has been emerging in the United States. The federal government is responsible for establishing noise emission standards. State and local governments are responsible for developing ambient noise level standards and then choosing from among a group of possible "use" controls the set of use controls they believe are necessary to achieve the established standards. State and local governments will also bear the brunt of enforce-

11. Table VIII-1 is derived from Tables IV-4 and IV-5 *supra*.

ment responsibilities for both emission and ambient level standards.

The federal government has adopted a cautious approach to noise emission standards. While standards for new and in-use medium and heavy-duty trucks have been established, noise emission standards for other types of motor vehicles will be established in the years to come.

State and local governments have adopted an even more cautious approach to ambient noise level standards and use controls. Compared with other American states and cities, New York State and New York City would have to be characterized as progressive examples of noise regulation at the state and local level. Their regulatory schemes provide examples of both effective and ineffective actions by state and local governments in response to the noise problem.

Inaction or ineffective action by state and local governments can be traced in large part to the "lively" debate between federal regulators and state and local regulators that has been sparked by the emerging division of responsibilities. State and local regulators are concerned about the effect federal emission standards will have on state or local ambient level standards.

State and local regulators are not free to choose whatever ambient level standards they desire. For example, state or local regulators would be unable to establish an ambient noise level standard of 40 dB(A) along highways within their jurisdiction if federal noise emission standards for motor vehicles averaged 78 dB(A). Motor vehicles complying with federal emission standards could not satisfy state ambient level standards without modifying the source. Source modification is the dividing line between emission and ambient level standards. Consequently, state and local regulators are free to choose ambient level standards as long as the ambient level standards do not require source modification.

This lack of absolute freedom, however, does not mean that state and local regulators are bound in their choice of an appropriate ambient noise level standard by the federal noise emission standards. A variety of use controls exist that alone or in concert are surprisingly effective in assisting state or local regulators to meet ambient level standards. Some of the use controls with which state and local governments have experimented include prohibiting the use of a highway or portion thereof, limiting the use of a highway or portion thereof, rerouting motor vehicles, regulating commercial traffic, synchronizing traffic lights, lowering speed limits, and prohibiting the use of horns, bells, and sirens.

State and local regulators are concerned (agitated might be a more appropriate term) about the prospect of federal preemption.<sup>12</sup> The New Truck Regulations and Motor Carrier Regulations require state and local noise emission standards for medium and heavy-duty trucks to be identical to the federal noise emission standards. State and local regulators contend that government at their level is more inclined to establish stringent noise emission standards than is the federal government. As a result, state and local regulators argue that federal preemption means that more stringent state and local noise emission standards will be preempted and replaced by less stringent federal noise emission standards.

One obvious way of testing the validity of this argument is to compare the noise emission standards chosen by the federal government with state and local noise emission standards in existence when the federal noise emission standards were established. Such a comparison is limited since the federal government has only established noise emission standards for new and in-use medium trucks. Noise emission standards incorporated by the federal government in the Motor Carrier Regulations were either identical or similar to the state and local noise emission standards in existence when the federal noise emission standards were established.<sup>13</sup> Nevertheless, the controversy continues to rage be-

---

12. In the American regulatory scheme, federal noise emission standards preempt state and local noise emission standards, *i.e.*, state and local noise emission standards must be identical to federal noise emission standards.

Preemption is also an issue in the Federal Republic of Germany. As a result of federal preemption, neither Bavaria nor Munich has any law, ordinance, or regulation that controls motor vehicle noise at its source.

13. The Motor Carrier Regulations established three noise emission standards: 86 dB(A) for motor carriers traveling 35 mph/56 kmph, 88 dB(A) for stationary motor carriers, and 90 dB(A) for motor carriers traveling more than 35 mph /56 kmph. At the time these federal noise emission standards were established, New York State's Vehicle and Traffic Law § 386 contained a noise emission standard of 88 dB(A) for "motor vehicles" traveling 35 mph /56 kmph or less, and art. V of New York City's Noise Control Code contained a noise emission standard of 86 dB(A) for motor vehicles with a manufacturer's gross vehicle rating of 8000 lbs. or more traveling 35 mph /56 kmph or less.

Both New York City's noise emission standard and the federal noise emission standard are based on the speed at which the motor vehicle is moving. Both draw a distinction between motor vehicles traveling 35 mph /56 kmph or less and motor vehicles traveling more than 35 mph /56 kmph. Both use a nearly identical procedure to measure the noise emitted. Both set the same permissible noise level for heavy motor vehicles; 86 dB(A) for motor vehicles traveling 35 mph /56 kmph or less and 90 dB(A) for motor vehicles traveling more than 35 mph /56 kmph.

There are, however, differences. New York City's noise emission standard applies to any motor vehicles or motorcycle; the federal noise emission standard applies to motor vehicles with a gross vehicle weight rating greater than 10,000 lbs. operated in interstate

tween federal regulators and state and local regulators. Many state and local regulators seem to be almost obsessed by the preemption issue. This obsession is ill advised and a tragic waste of effort and resources.

The issue whether noise emission standards should be federal or state and local has been decided. Federal noise emission standards are here to stay both in the United States and in the Federal Republic of Germany. The issue that has yet to be decided in the United States is whether state and local regulators will retain their powers over ambient level standards. In this respect, the German experience is or at least should be a clear warning to state and local regulators in this country that the federal government can only be expected to condone inaction or ineffective action for a short period of time before stepping in and assuming responsibility for ambient level standards as well as emission standards. The message to state and local governments is simple: either take effective action or face federal preemption of ambient level standards.

## *2. An effective enforcement strategy for state and local governments*

State and local regulators in the United States should squarely confront the challenge posed by the German experience and devote their efforts and resources to developing ambient noise level standards, choosing appropriate use controls to achieve those standards and enforcing both emission and ambient level standards. The remainder of this Section outlines a proposed enforcement strategy for state and local governments.

*a. Enactment of a modern noise law.* The first ingredient of an effective enforcement strategy is the enactment of a modern noise law that will allow a state or local government to cope with noise sources within the boundaries of its jurisdiction. Most state and local governments have noise provisions in their existing laws. These provisions have been adopted over the years in response to particular problems. Muffler laws, which usually prohibit unnecessary noise, are one of the more popular motor vehicle noise provisions at the state and local level. Many noise provisions can only be described as "quaint." They were enacted to deal with noise sources whose contribution to community noise

---

commerce. The federal noise emission standard applies to the motor vehicle itself; New York City's noise emission standard applies not only to the motor vehicle but also to any combination of vehicles towed by the motor vehicle.

vis-à-vis newer noise sources has diminished or even vanished. For example, section 89 of New York State's Village Law authorized the Board of Trustees of a village to "regulate and prohibit whistling, ringing of bells, and other noises."<sup>14</sup>

The types of noise provisions are themselves confusing. This confusion is only compounded by two additional factors: Noise provisions have been enacted into state and local law over a considerable period of time; and little or no effort has been made either to cross-reference or to collect these noise provisions in one place. This haphazard approach is uniformly condemned by American and German noise experts. They advocate, as a minimum acceptable goal, collecting or cross-referencing existing noise provisions. They prefer enacting a comprehensive noise law.

Each state or local government should begin the process of enacting a modern noise law by carefully analyzing all existing noise provisions. Outdated noise provisions should be deleted. The remaining noise provisions should be collected in one section or cross-referenced if the state or local government decides that the enactment of a comprehensive noise law is impossible or impractical for some reason.

If the state or local government decides to enact a comprehensive noise law, that noise law can take a variety of forms, depending on the provisions that are made a part of the law. No noise law would be comprehensive unless noise emission and ambient noise level standards were numbered among its provisions.

State and local governments have three options open to them: (1) a noise law that contains subjective noise emission standards, (2) a noise law that contains objective noise emission standards, or (3) a noise law that contains both subjective and objective noise emission standards. State and local governments have traditionally chosen the first option.<sup>15</sup> The muffler provisions in New York State's Vehicle and Traffic Law illustrate the subjective approach to noise emission standards. Section 381(1) prohibits "unnecessary noise." Sections 375(31) and 381(11) have

---

14. Law of Apr. 4, 1927, ch. 650, sec. 6-d, § 89 (48), 1927 N.Y. Laws 1575 (repealed 1972).

15. The German experience differs from the American experience in at least two respects. First, noise emission standards have always been set by the federal government. Second, the Federal Republic of Germany initially opted for objective noise emission standards, subsequently substituted a subjective noise emission standard—"best available technology"—and then returned to objective noise emission standards.

abandoned "unnecessary noise" in favor of "excessive or unusual noise."<sup>16</sup>

In response to difficulties with the subjective approach and because of changes in the mix of noise sources, state and local governments increasingly look with favor on the second option.<sup>17</sup> They like the objective nature of noise emission standards formulated in terms of decibels, but they dislike the complexities and costs associated with objective noise emission standards and the fact that sooner or later their noise emission standards will be preempted by federal standards. Consequently, state and local governments have opted in favor of the third option and have enacted noise laws that contain both subjective and objective noise emission standards.<sup>18</sup> New York City's Noise Control Code

16. New York courts view "excessive or unusual noise" more sympathetically than "unnecessary noise."

17. Section 386 of the New York Vehicle and Traffic Law is an example of an objective noise emission standard. Section 386 was criticized by the Mayor's Task Force on Noise Control as "completely unrealistic for conditions in [New York] City." *NEW YORK CITY MAYOR'S TASK FORCE ON NOISE CONTROL, TOWARD A QUIETER CITY 10* (1970). Section 386 can also be criticized in terms of infrequent and limited application.

18. The Council of State Governments and the National Institute of Municipal Law Officers (NIMLO) have recommended model laws that contain both subjective and objective noise emission standards. See *Model State Noise Control Act* in 33 *THE COUNCIL OF STATE GOVERNMENTS, 1974 SUGGESTED STATE LEGISLATION 10* (1974); *NIMLO Model Noise Ordinance* in *NIMLO, LAW AND THE MUNICIPAL ECOLOGY, PART TWO: NOISE POLLUTION, NIMLO RESEARCH REPORT 156*, at 77 (1970).

The Model State Noise Control Act approaches the question of noise emission standards indirectly. Section 201(a)(2) provides for

noise emission standards for products which, in the administrator's judgement, are major sources of noise, or are products for which noise emission standards are feasible and are requisite to protect the public health and welfare. Such standards may include but shall not be limited to adoption by reference of standards or regulations adopted by the administrator of [EPA] pursuant to the Noise Control Act of 1972 (Public Law 92-574) or any amendment thereto

This language is sufficiently broad to permit the adoption of subjective and objective noise emission standards.

NIMLO's Model Noise Ordinance deals directly with subjective and objective noise emission standards. Section 8-303 contains a subjective—unnecessary noise—standard. Unnecessary noise is defined in terms of 17 noise sources: Horns, signaling devices, etc.; radios, phonographs, etc.; loud speakers, amplifiers for advertising; yelling, shouting, etc.; animals, birds, etc.; steam whistles; exhausts; defects in vehicle or load; loading, unloading, opening boxes; construction or repairing of buildings; schools, courts, churches, hospitals; hawkers, peddlers; metal rails, pillars, and columns, transportation thereof; street railway cars, operation thereof; pile drivers, hammers, etc.; blowers.

Four of these sources involve motor-vehicle-related noise. Section 8-303(A) prohibits:

[t]he sounding of any horn or signaling device on any automobile, motorcycle . . . or other vehicle on any street or public place of the city, except as a danger warning; the creation by means of any such signaling device of any unreasonably loud or harsh sound; and the sounding of any such device for an unnecessary

illustrates this approach: article III prohibits unnecessary noise;<sup>19</sup> article V establishes objective noise emission standards for certain categories of devices.<sup>20</sup>

The popularity of this third option derives, in part, from its recognition of a definitional fact and the enforcement realities that flow from that definitional fact. The definitional fact is that noise can be divided into "mechanical" noise and "people" noise. "Mechanical" noise is particularly well suited to objective measurement. A motor vehicle either does or does not comply with a noise emission standard expressed in decibels. This approach

---

and unreasonable period of time. The use of any signaling device except one operated by hand or electricity; the use of any horn, whistle or other device operated by engine exhaust; and the use of any such signaling device when traffic is for any reason held up.

"The discharge into the open air of the exhaust of any . . . motor vehicle except through a muffler or other device which will effectively prevent loud or explosive noises therefrom" is prohibited by § 8-303(G). Section 8-303(H) prohibits "[t]he use of any automobile, motorcycle, or vehicle so out of repair, so loaded or in such manner as to create loud and unnecessary grating, grinding, rattling or other noise." "The creation of a loud and excessive noise in connection with loading or unloading any vehicle" is prohibited by § 8-303(I).

Alternative § 8-303 contains objective—decibel—standards. The noise emission standards for motor vehicles are found in a table in the model ordinance. A modified version of this table appears below:

Category	Noise Emission Standard (in dB(A))	
	Measured at 50 feet	Measured at 25 feet
<b>Trucks and buses</b>		
Over 10,000 lbs.	87	93
Under 10,000 lbs.	80	86
<b>Passenger cars</b>	78	84
<b>Motorcycles</b>	87	93

19. If a state or local government adopts an unnecessary noise standard, some attempt should be made to define what constitutes "unnecessary noise." For example, § 30 of the Federal Republic of Germany's Motor Vehicle Ordinance, as amplified by the Motor Vehicle Regulations, establishes five categories of activities that constitute unnecessary noise.

Care, however, must be taken in establishing categories of activities that constitute unnecessary noise. For example, section 1403.3-4.07 of New York City's Noise Control Code prohibits unnecessary bird noise. This provision caused some initial enforcement headaches.

20. Objective noise emission standards are established for numerous motor-vehicle-related noises: §§ 1403.3-5.03 (motor vehicles); 1403.3-5.15 (refuse compacting vehicles); 1403.3-5.17 (claxons); 1403.3-5.19 (emergency signal devices).



possesses fewer ambiguities and hence avoids some of the potential problems associated with a noise emission standard formulated in terms of unnecessary noise. Objective standards, however, are more difficult to enforce. They require special equipment, a testing area, and trained personnel. All of these requirements add to the enforcement budget. In a time when governments at all levels are forced to scrutinize their budgets with ever-increasing care, state and local governments, quite understandably, are reluctant to embark upon any new program that might add to their existing budgetary miseries. A cautious approach dictated by financial realities has impeded and probably will continue to impede the adoption of objective noise emission standards. Fortunately, there are some hopeful signs. The cost of equipment, for example, has been reduced by advances in technology. This trend, moreover, should continue. In addition, New York City's experience suggests that a small, highly trained environmental police force can effectively enforce objective noise emission standards.

"People" noise, unlike mechanical noise, is not well suited to objective measurement. Individuals who are socializing at a party seldom view the noise created by their activities as unreasonable. Neighbors, particularly if their rest is disturbed, may view the party in a different light. In this situation, an environmental police officer could be summoned to take a decibel reading, but common sense dictates that matters of this type are better left to the city police, who will be called upon to make a subjective judgment whether the party is unreasonably noisy.

A comprehensive noise law that contains both subjective and objective noise emission standards permits an efficient division of labor. In New York City matters involving mechanical noise are within the jurisdiction of the small, highly trained environmental police force. "People" noise is handled by the city police.

In addition to noise emission standards, a comprehensive noise law should also contain ambient noise level standards. Ambient level standards can be formulated either in uniform terms—a single standard is adopted for the entire geographic area within the jurisdiction of the state or local government—or in terms of land use—industrial areas, for example, will be treated differently from residential areas.

Both the Federal Republic of Germany and New York City have concluded that uniform ambient noise level standards are impractical. They are impractical because they ignore the relationship between land use and achievable ambient level stan-

dards.<sup>21</sup> The ambient level standard along a multilane interstate highway necessarily will be higher than the ambient level standard in a quiet residential area.

The German approach has been to divide urban areas into land-use categories and to assign ambient noise level standards to each category.<sup>22</sup> DIN 18005 is used in the planning process.<sup>23</sup> Five land-use categories plus a "special" category are recognized.<sup>24</sup> VDI 2058-1 is to be used in urban areas that have progressed beyond the developing stage into the developed stage. Six land-use categories are recognized.<sup>25</sup>

Bavaria and Munich have been content to adopt the ambient noise level standards recommended by DIN 18005 and VDI 2058-1. Other German governments at the state and local level have preferred a more activist approach. They have conducted noise surveys, constructed noise maps, and then divided the area under their jurisdiction into land-use categories based on the noise maps.<sup>26</sup>

Nothing analogous to DIN 18005 or VDI 2058-1 exists in the United States. As a result, New York City's approach to ambient noise level standards differs from the German approach. There are two provisions in New York City's Noise Control Code that

---

21. EPA does not dispute the relationship between land use and achievable ambient noise level standards. Nevertheless, it does take the position that some upper limit can and should be imposed on these standards. The limits chosen by EPA are: 70 dB(A) to avoid hearing loss; 55 dB(A) to avoid outdoor interference and annoyance; 45 dB(A) to avoid indoor interference and annoyance. U.S. ENVIRONMENTAL PROTECTION AGENCY, INFORMATION ON LEVELS OF ENVIRONMENTAL NOISE REQUISITE TO PROTECT PUBLIC HEALTH AND WELFARE WITH AN ADEQUATE MARGIN OF SAFETY 3 (1974).

22. Under § 42 of the recently enacted Federal Ambient Levels Protection Law a property owner has a cause of action if (1) a public highway is constructed or significantly modified and (2) the ambient noise level resulting from these changed circumstances exceeds the permissible ambient level established by § 43(1)(1). Section 42 represents a powerful new noise abatement tool, but nothing can be done until permissible ambient levels are established pursuant to § 43.

23. Munich's 1974 Report contrasts the noise levels recommended by DIN 18005 and actual noise levels along four streets in Munich. According to the 1974 Report, the noise levels recommended by DIN 18005 can only be achieved where "there is a significant amount of free area and no consideration need be given to the price of land." 1974 Report, *supra* note 3, at 4.

24. The recommended ambient noise levels assigned to these land-use categories are shown in Table V-8 *supra*.

25. The recommended ambient noise levels assigned to these land-use categories are shown in Table V-6 *supra*.

26. Two Bavarian agencies, the Ministry for Land Development and the Environment and the Office of Environmental Protection, are jointly preparing noise maps for areas which are subjected to particularly serious noise. In contrast, Munich has not prepared and does not plan to prepare noise maps.

involve ambient level standards. Section 1403.3-4.19 provides for the creation of noise-sensitive zones. Schools, hospitals, and courts are designated as noise-sensitive zones by the Noise Control Code. The administrator and the Board of Health, however, are not restricted to these three noise-sensitive zones. They can create additional noise-sensitive zones if "public health and comfort" require. Section 1403.3-6.01 authorizes the administrator to submit proposed "ambient noise quality zones" to the city council for enactment.

In his submission the administrator is to indicate the criteria and standards applicable within each ambient noise quality zone. The Noise Control Code lists seven factors that are to be considered in establishing "ambient noise quality zones": (1) the uses and activities permitted by zoning regulations in such zones, (2) the intensity of sound levels produced by activities and devices in such zones, (3) the time at which such sound levels occur, (4) the duration of such sound levels, (5) the proximity of such activities and devices to buildings and to dwellings, (6) whether the sound levels produced by such devices and activities are recurrent, intermittent, or constant, and (7) the density of habitation of such zones.

*b. Use controls.* Choosing an appropriate set of use controls is the second ingredient of an effective enforcement strategy. Although the term "use controls" is susceptible to an expansive definition, a more limited definition is employed here. Use controls simply mean operational modifications.

In Section I a variety of operational modifications were mentioned. Subsequent Sections have shown that state and local governments in the United States and the Federal Republic of Germany have experimented with most of these operational modifications. Their experience with these operational modifications is summarized in the succeeding paragraphs and provides a guide to state or local regulators as they choose the set of use controls they wish to implement in their own jurisdictions.

*Prohibiting the use of horns, bells, and sirens.* Most state and local governments in the United States and the Federal Republic of Germany have prohibitions against the use of horns, bells, and sirens under some circumstances. Section 1403.3-4.05 of New York City's Noise Control Code prohibits the operation or use of any sound signal device that creates unnecessary noise.<sup>27</sup> During

---

27. Unnecessary noise is defined in subjective terms for all motor vehicles prior to the 1974 model year. Thereafter, unnecessary noise is defined in objective terms as being equivalent to 75 dB(A).

June and July of 1973 New York City's Division of Noise Enforcement vigorously enforced section 1403.3-4.05 and issued numerous summons for hornhonking. Many of those who received a summons objected to the necessity of appearing in court and the amount of the fine—fifty dollars. Apparently, the courts found the objection to the amount of the fine persuasive because they imposed fines of two dollars rather than fifty dollars.

This episode graphically illustrates how an enforcement program can flounder due to an uncoordinated enforcement effort. Regulators almost unanimously agree that stiffer penalties are required, but courts balk at overly stiff penalties. The challenge, then, is to maximize penalties without endangering the enforcement effort. In the New York City case, the courts were unprepared to impose fifty dollar fines, and the Division of Noise Enforcement was unwilling to enforce section 1403.3-4.05 when the courts would only impose two dollar fines. The result was and is a standoff. Since 1975 the Division of Noise Enforcement has made no attempt to enforce section 1403.3-4.05 but has turned its attention to other noise sources.

The operation and use of any emergency signal device, unless on an authorized emergency vehicle responding to an emergency, is prohibited by section 1403.3-4.09 of New York City's Noise Control Code. Even if the emergency signal device is mounted on the proper type of motor vehicle and is used in the prescribed fashion, a noise emission standard of 90 dB(A) applies to emergency signal devices after June 30, 1973, by virtue of section 1403.3-5.19.

Section 24 of the Bavarian Garage Regulations prohibits "honking . . . in and near garages, parking places, entrances, and exits when such noise unreasonably disturbs the neighborhood."<sup>28</sup> This provision is buttressed by section 16 of Motor Vehicle Ordinance (StVO), which prohibits multitone warning devices and limits the use of approved warning devices to two situations: when overtaking another motorist and when warning of danger.

*Lowering speed limits.* Both American and German motorists are subject to posted speed limits. While some attention has been given to the relationship between speed and noise emissions in the United States, the Germans have examined this question in considerable detail and have discovered that this operational

---

28. Landesverordnung des Bayerisches Staatsministeriums des Innern über Garagen (Garagenverordnung)(Bavarian Garage Regulations), Apr. 13, 1966, § 24, [1966] GVBl 162.

modification has limited utility.

Bavaria has published data<sup>29</sup> suggesting that lowering speed limits from 100 kmph/62 mph to 70 kmph/43 mph can result in a one-third decrease in the continuous noise level but that lowering speed limits below 50 kmph/31 mph may actually increase the continuous noise level because the motor vehicles will then be required to operate in low gear. Based on these and similar findings, the German Federal Institute for Highways determined that the most desirable speed from the standpoint of noise emissions is 70 to 80 kmph/43 to 50 mph for automobiles and 40 to 60 kmph/25 to 37 mph for trucks.

As a result, every effort should be made to bring speed limits within these parameters. Lower or higher speed limits should be avoided. Other factors, however, may dictate different speed limits. The Guidelines Governing Traffic Measures to Protect Sleep (Guidelines to Protect Sleep) promulgated by the Federal Republic of Germany's Minister of Transportation recognize that several factors may be involved, and take the position that the decision to lower speed limits should be made on a case-by-case basis and only after local conditions have been examined.

*Synchronizing traffic lights.* Synchronized traffic lights are used in the United States and the Federal Republic of Germany to improve traffic flow. Only minor attention, however, has been given to this operational modification on noise emissions by Americans. The Germans, in contrast, have discussed synchronized traffic lights—they refer to this operational modification as the "green wave" effect—fairly extensively.

All of the discussions, however, seem to have been in the context of evening-hour use. The discussion in the Guidelines to Protect Sleep, for example, focuses on evening-hour use and emphasizes the differences in traffic patterns and number of motor vehicles between evening hours and daylight hours.

Munich has had some practical experience with the "green wave" effect. After a report, *Nighttime Operational Prohibitions for Mopeds, Motorcycles, and Trucks; Technical Requirements for Construction Equipment (1970 Report)*, concluded that turning off traffic signals was the best way to reduce brake noise, particularly between 10:00 p.m. and 6:00 a.m., Munich decided

---

29. Graphic representation of this data that illustrates the relationship between speed and continuous noise level is shown in Graph VI-2 *supra*.

to experiment with this proposal on a limited basis by turning off traffic signals in Schwabing, the bohemian section of the city. The results of this experiment were not very satisfactory. Brake noise may have diminished, but the number of accidents in Schwabing rose significantly.

*Regulating commercial traffic.* State and local governments in the United States and the Federal Republic of Germany regulate commercial traffic. In the United States the bases for these regulations appear to be considerations other than noise. The Federal Republic of Germany regulates the loading and unloading of motor vehicles by means of section 22 of the StVO. Section 22 contains an unreasonable noise standard, *i.e.*, loading or unloading of vehicles must not cause unreasonable noise. Commercial traffic usually is truck traffic. Since trucks are such a significant contributor to community noise, the noise reduction potential of this operational modification deserves closer examination by American regulators.

*Rerouting motor vehicles.* Rerouting for purposes of noise abatement has rarely been used by American regulators. German regulators have made somewhat greater use of this operational modification, but even the German use has been limited. Several factors enunciated in the Guidelines to Protect Sleep help to explain the generally unfavorable reaction to rerouting. For instance, rerouting tends to hamper the flow of traffic. More significantly, rerouting usually simply shifts the problem from one location to another.

One-way streets are an exception. They are fairly extensively used in Germany because one-way traffic produces less intensive and more homogeneous sound than two-way traffic. In its report, *The Municipal-Policy Aspects of Environmental Protection in Munich (1971 Report)*, Munich's Office of City Development recommended that one-way streets be used not only to reduce noise but also to reduce the number of motor vehicles near areas closed to traffic.

In spite of the generally unfavorable reaction to its use, rerouting is used and will be used in the future to reroute traffic around or away from residential areas. The Guidelines to Protect Sleep recognize this fact and provide that the new route must be reasonable not only from the motorists' standpoint but also from the standpoint of the residents along the new route. American regulators should likewise consider the circumstances under which resort should be made to rerouting.

*Limiting the use of a highway.* Use limitations are another

form of operational modification deserving closer attention by American regulators. Such limitations can be placed on particular types of motor vehicles or on times of operation. Since trucks are a major contributor to community noise, most of the motor vehicle type limitations are directed at them. Type and time limitations are frequently coupled.

Section 30 of the StVO, for example, prohibits the operation, on Sundays and holidays from midnight to 10:00 p.m. of trucks whose gross weight exceeds 7.5 tons. Notably, German regulators have imposed this limitation on some but not all trucks. Their view is that a partial limitation is preferable to a total limitation, particularly if the partial limitation is all that is necessary to reach a desired noise level.

Section 30 also prohibits unnecessary noise. This prohibition is amplified by the Motor Vehicle Regulations, which require a permit to engage in motor vehicle activities that could disturb people who are sleeping during "nighttime," which is defined as the period from 10:00 p.m. to 6:00 a.m. Apparently, all motor vehicle activities are subject to this permit requirement, except for those activities that take place far from areas of human habitation and that involve only a few motor vehicles.

The Guidelines to Protect Sleep respond slightly differently to the same problem. They impose limitations on motor vehicles directly through a permit mechanism. Limitations under these guidelines, however, are subject to a variety of conditions. The limitations apply only to residential areas. They will not be applied unless there is an energy-equivalent continuous noise level that exceeds 65 dB(A) between 11:00 p.m. and 6:00 a.m. In addition, before a limitation can be imposed, either a reasonable detour route must be offered or sufficient parking must be found.

Munich has also been exploring use limitation options. Its 1970 Report was written in response to a proposal asking the Munich City Council to investigate possible restrictions on motorcycle and truck use during evening hours. The 1970 Report concluded that speed and operational limitations were available, but that exceptions would have to be made for principal streets if operational limitations were chosen. Additionally, the 1971 Report recommended that all streets in residential areas be closed to traffic between 10:00 p.m. and 6:00 a.m. and that most other streets be closed to truck and motorcycle traffic during these same hours.

*Prohibiting the use of a highway.* Prohibitions are routinely used in the United States and the Federal Republic of Germany

to make repairs or to prevent unnecessary damage to a highway. The use of such a prohibition to abate noise, however, is less common.

Munich, like a number of other cities, has closed certain areas of the city to motor vehicles. The *1971 Report* recommends that the number of closed areas be increased and that traffic limitations or one-way streets be used to reduce the number of motor vehicles near such closed areas.

The Motor Vehicle Regulations empower German regulators to impose prohibitions in residential areas where people are sleeping or in "other areas" deserving similar protection. "Other areas" include but are not limited to areas near hospitals and convalescent homes and other areas where recuperation or relaxation take place.

Prohibiting the use of a highway or a portion of it to motor vehicles is a serious step. Accordingly, the Motor Vehicle Regulations contain procedures that must be complied with before a highway is closed to all traffic. These procedures include consultation with appropriate officials and consideration of all reasonable detours. The Guidelines to Protect Sleep indicate that the existence of a reasonable detour is not a condition precedent to prohibition. However, prohibitions usually are not considered unless a reasonable detour exists.

c. *Transmission path modification.* The third ingredient of an effective enforcement strategy is transmission path modification. Modifying the transmission path taken by noise can be used by state and local governments to enhance the effectiveness of their use controls.

*Evaluating noise in the highway planning process.* Noise evaluations have become an integral part of the highway planning process at the federal level in both the United States and the Federal Republic of Germany. More attention needs to be given to noise evaluation at the state and local level.

During the 1970's the United States Federal Highway Administration (FHWA) has become increasingly sensitive to the potential social, economic, and environmental effects of proposed highway projects in the United States. FHWA's planning goal, therefore, is to provide full consideration of these effects from the system-planning stage through the location stage to the design stage. Process guidelines are the device chosen by FHWA to accomplish this goal. The process itself involves three steps:

- (1) Social, economic, and environmental effects [are] identified and studied early enough to permit analysis and con-



sideration while alternatives are being formulated and evaluated.

(2) Other agencies and the public [are] involved in system planning and project development early enough to influence technical studies and final decisions.

(3) Appropriate consideration [is] given to reasonable alternatives, including the alternative of not building the project and alternative modes.<sup>30</sup>

Noise has social, economic, and environmental effects. In order to minimize the adverse effects of noise, FHWA has developed noise level standards for federal-aid highways.<sup>31</sup>

In analyzing any federal-aid highway project, FHWA uses a six step procedure:<sup>32</sup> (1) existing land uses or activities that may be affected are identified, (2) highway-generated noise levels are predicted for each alternative being studied, (3) existing noise levels for developed land uses or activities are measured, (4) predicted noise levels are compared with design noise levels and with existing noise levels, (5) alternative measures for reducing or eliminating noise are evaluated, and (6) situations where an exception to the design noise levels are warranted are identified.

Predicted noise levels sometimes exceed design noise levels. In such a situation, noise measures must be taken to bring predicted noise levels into conformity with design noise levels. Noise abatement measures can be exceedingly expensive. In recognition of this fact, FHWA has expanded the definition of "highway projects" to include noise abatement measures in order to make federal funds available for noise abatement measures.

Federal-aid highway planning is initiated by the federal government, but state and local governments have their responsibilities in the planning process. State highway agencies are responsible for assuring compatibility between federal-aid highways and existing land uses. In order to promote compatibility, state highway agencies are urged to cooperate with local governments by furnishing them with "approximate generalized future noise levels for various distances from the highway improvement" and "information that may be useful . . . to protect future land development from becoming incompatible with anticipated highway noise levels."<sup>33</sup> Local governments are then responsible for controlling land development and zoning.

30. 23 C.F.R. § 795.3(b) (1979).

31. For a summarization of these standards, see Table II-15 *supra*.

32. See 23 C.F.R. § 772.11(b) (1979).

33. *Id.* § 772.17 (a)-(b).

The planning goal set by the Federal Republic of Germany is articulated by part A of the Bavarian Ministry of the Interior's announcement entitled "Considering Noise Control on Major Thoroughfares in Zoning and Highway Planning" (Highway Planning Announcement): "New areas of construction adjacent to existing or planned highways, particularly through or major highways, are to be planned so as to reduce as far as possible the exposure of residents to unreasonable noise."<sup>34</sup> The measure preferred by the Germans in achieving this goal is spatial separation of highways and areas where people live, work, or play. If spatial separation is impossible or impractical, zoning regulations should specify the measures that will be taken to minimize harmful noise.

German highway planners cannot restrict their considerations to traffic requirements but must also consider "other needs of the populace, particularly a healthful environment."<sup>35</sup> They, therefore, see noise as an integral part of the planning process. Alternative routes are analyzed in terms of noise impact. As soon as construction seems probable, local governments are told of the proposed route and the expected ambient noise level. Local governments then have the responsibility of coordinating zoning regulations with the highway plans. This attitude about the place of noise in the planning process has been fostered by the administrative courts, which have repeatedly ruled that planning decisions are defective if they fail to contain the necessary noise protection measures.

Recent changes in federal law in Germany further reinforce this attitude. The Federal Highway Law provides for compensation to the owner of property when the expected use of structures on his property is adversely affected by noise, if the ambient noise level exceeds 75 dB(A). The Federal Highway Law also prohibits the construction of homes along federal highways in areas where the ambient noise level exceeds 65 dB(A). An even stricter ambient noise level applies to hospitals, rest homes, schools, and similar structures. Section 41 of the recently enacted Federal Ambient Levels Protection Law requires protective measures whenever significant changes on public highways lead to a noticeable increase in harmful noise effects that would be avoidable by

---

34. Bekanntmachung des Bayerischen Staatsministeriums des Innern, Berücksichtigung des Lärmschutzes am Hauptverkehrsstrassen in der Bauleit- und Strassenplanung (Considering Noise Control on Major Thoroughfares in Zoning and Highway Planning) 1 (1973) [hereinafter cited as Highway Planning Announcement].

35. *Id.* at 5.

applying existing technology. Bavaria has interpreted "a noticeable increase" as an increase of more than 4 dB(A) in the ambient noise level.<sup>36</sup>

No federal funds are available under German law if a party other than the federal government wishes to take noise abatement measures. This restriction has caused some problems because state and local governments have wanted to undertake noise abatement measures financed in whole or in part by the federal government but have been unable to persuade the federal government of the desirability of the contemplated noise abatement measures. The Bavarian Ministry of the Interior, for example, discussed this restriction with the federal Minister of Transportation and suggested that federal funds ought to be made available in circumstances other than those where the federal government wished to take noise abatement measures. Unfortunately, these discussions proved fruitless.

*Maintaining separation of highways and places where people live, work, or play.* Spatial separation is an aspect of the planning process that has received attention both in the United States and the Federal Republic of Germany. Consequently, this method of modifying the path that noise transmission takes will be accorded individual treatment. FHWA has determined that the acquisition of a wider right-of-way reduces noise at the right-of-way line. For example, a 10 dB(A) reduction at the right-of-way line is possible if 200 to 300 feet /60.6 to 90.9 meters of additional right-of-way is acquired on either side of the highway.

According to information collected by the Federal Republic of Germany, the average noise level decreases importantly as the distance from a highly traveled highway increases. Two hundred meters appears to be a significant distance. Beyond 200 meters /656 feet, distance is no longer a significant factor in reducing the average noise level. Weather conditions, however, do become a significant factor beyond 200 meters /656 feet. Wind and temperature, for example, can cause a reduction of up to 20 dB(A).

Bavaria's Highway Planning Announcement stresses the importance of spatial separation between highways and structures and encourages zoning authorities to observe the spatial separation recommended by DIN 18005. In response to the Highway Planning Announcement, article 25 of the Bavarian Highway and Street Law was amended to prohibit construction of certain

---

36. Letter from Oberste Baubehörde (Bavarian Building Department) to several governmental agencies, at 2 (May 6, 1974).

structures where certain ambient noise levels existed. Article 25(1) now provides as follows:

On free stretches of state and county highways and on connecting highways within municipalities, residences may not be constructed in areas where the ambient noise level exceeds 65 dB(A), and hospitals, rest homes, schools and similar structures deserving protection from noise may not be constructed where the ambient noise level exceeds 60 dB(A) . . . .<sup>37</sup>

Article 25(1) at first glance appears to be inconsistent with the Highway Planning Announcement. Actually, article 25(1) supplements the Highway Planning Announcement by providing additional protection for structures where the separation of the highway from the structure to be constructed exceeds the minimum spatial separation recommended by DIN 18005.

*Using zoning.* In discussing the first ingredient of an effective enforcement strategy, the enactment of a modern noise law, zoning was discussed in conjunction with ambient noise level standards. A discussion of the uses of zoning in the Federal Republic of Germany follows to supplement that discussion.

The Building Use Regulations divide real estate into various categories and specify what activities are permissible within each category. Its intent is to protect individuals within a given area from disturbances whose source is within the same area. If the source is outside the area, the Bavarian Ministry of the Interior's announcement entitled "Considering Noise Control in Urban Construction" (Urban Construction Announcement) lists several ways of dealing with the problem: spatial separation, regulation of intermediate areas, and noise screens. Section 1(4) of the Federal Building Law requires that the zoning process consider social and cultural needs as well as safety and health. This requirement dictates that noise be kept as far away from noise-sensitive areas, particularly residential areas or areas that serve similar useful purposes, as possible.

DIN 18005 contains instructions that assist zoning authorities in achieving this goal. According to the Highway Planning Announcement, an effective zoning program consists of the following elements: (1) compilation of data, (2) use of spatial separation or some other noise protection measure if spatial separation is impractical or impossible, (3) notation in the plans sub-

---

37. Bayerisches Strassen- und Wegegesetz (Bavarian Highway and Street Law), Jul. 2, 1974, art. 25(1), [1974] GVBl 333.

mitted to the zoning authorities of the noise protection measures, and (4) review of the plans to ascertain their compliance with applicable standards. Plans that do not protect against noise "are not consistent with the well-being of the populace and do not serve their safety and health."<sup>38</sup> Under these circumstances, no approval is possible unless the plans are brought into compliance with the noise protection requirements or otherwise modified.

Moreover, plans that may provide some protection against noise but that either ignore the recommended ambient noise levels established by DIN 18005 or deviate from them cannot be summarily approved. Local zoning authorities are forced to justify the variance and to explain why it is consistent with the land-use plan. As one might expect, this additional requirement tends to discourage nonconforming building plans.

*Using the natural or manmade environment.* Both the United States and the Federal Republic of Germany have studied the ways in which the environment can be used to abate noise. These studies have examined various elements of the manmade as well as the natural environment to determine their noise reduction potential. Terrain and vegetation are the two most frequently discussed elements of the natural environment that could be used to modify the transmission path of noise.

FHWA recommends that highways be aligned to take advantage of natural terrain. FHWA also recommends appropriate landscaping to reduce noise levels near highways.

The Federal Republic of Germany has been somewhat more specific about the noise reduction potential of vegetation. According to the Highway Construction Department's report entitled "Noise Protection in Highway Construction" (Highway Construction Report), which was attached to the Guidelines to Protect Sleep, the noise reduction potential of vegetation depends on the thickness of the plantings. Plantings up to 100 meters /328 feet can reduce noise by up to 10 dB(A); a noise reduction of up to 20 dB(A) can be achieved by plantings in excess of 100 meters /328 feet.

A number of manmade elements can be used to modify the transmission path of noise. One manmade element is the grade of the highway. Long, steep grades can result in a noise level 5 dB(A) greater than gentle grades.<sup>39</sup>

Road surface is a second manmade element. Greater atten-

---

38. Highway Planning Announcement, *supra* note 34, at 4.

39. FEDERAL HIGHWAY ADMIN., NOISE STANDARDS AND PROCEDURES 5 (1972).

tion has been given to this element by Germans than by Americans. The Highway Construction Report, for example, contained information that showed how highway surface influences noise level.<sup>40</sup> Road surface has been a particularly difficult problem for Munich. Many of the streets are cobblestone. A program has been underway for some time to cover these cobblestone streets with asphalt. Nevertheless, there were still approximately 2.9 million square meters /31.3 million square feet of "noisy" street surface that needed to be replaced by "quiet" street surface as of 1974. The cost of replacing this amount of street surface was estimated to be DM 28 million /\$14 million. Under a program recommended by the 1974 Report, Munich will replace 100,000 square meters /1,080,000 square feet a year at a yearly cost of DM 4 million.

Another manmade element is noise screens. FHWA recommends noise screens but cautions that they can only be effective if they are solid and have sufficient mass to prevent sound transmission. The German Highway Construction Report discusses walls and concludes that their noise reduction potential is directly proportional to the height of the wall. Low walls can reduce noise by up to 10 dB(A); a noise reduction of up to 20 dB(A) can be achieved by higher walls. Noise reductions in excess of 20 dB(A) can only be achieved by very high walls.

Depressed highways and tunnels are the final manmade elements to receive some attention. According to the Highway Construction Report, the noise reduction potential of depressed highways is directly proportional to the depth of the depression. Highways depressed up to 3 meters /9.8 feet can reduce noise by up to 10 dB(A). In order to reduce noise by up to 20 dB(A), the highway must be depressed in excess of 3 meters /9.8 feet. Tunnels are calculated to result in noise reductions in excess of 20 dB(A), but the expense involved in their construction limits their usefulness.

*d. Architectural modifications.* Architectural modifications are the fourth ingredient of an effective enforcement strategy. They range from noiseproofing individual structures to designing groups of structures or whole communities from the standpoint of noise protection.

FHWA has taken the position that there is no federal mandate for noiseproofing. Its recommendation is that the use of noiseproofing be restricted to schools, churches, libraries, hospitals, and auditoriums.

In contrast, there has been active consideration of noise-

---

40. This information is contained in Table V-3 *supra*.

proofing at the federal, state, and local level in the Federal Republic of Germany. The Highway Construction Report gives special attention to the noiseproofing characteristics of various types of windows and compares these characteristics with the characteristics of other windows, as shown in Table VIII-2.<sup>41</sup>

TABLE VIII-2

Window	Noise Reduction (in dB(A))
Closed regular window	up to 15
Closed double window	up to 25
Noiseproof window	30-60

The general philosophy of Bavaria's Building Ordinance is set out in article 3: "Building projects are to be planned, constructed, altered and maintained so that public safety and order, particularly life or health, will not be endangered."<sup>42</sup> Article 33(8) subsequently provides that ceilings and floors of dwelling places, entertainment rooms, or rooms adjoining entertainment rooms are to be noiseproofed.

On November 27, 1973, the Social Democratic Party proposed to Munich's City Council that all three levels of government "immediately undertake a program to install noiseproof windows in buildings on streets subject to severe disturbance and to provide the necessary funds for this program."<sup>43</sup> The questions posed by this proposal were whether Munich had the authority to induce or coerce owners to install noiseproof windows and, if so, who should pay for their installation.

Some estimates of the costs associated with installing noiseproof windows along three major streets in Munich were prepared to assist the City Council in evaluating the second question.<sup>44</sup> Based on these cost estimates, the 1974 Report concluded that owners and their tenants were not financially capable of bearing the costs of a noiseproofing program. The 1974 Report took the

41. Bundesminister für Verkehr, Abteilung Strassenbau, Lärmschutz im Strassenbau (Noise Protection in Highway Construction) (1974).

42. Bayerische Bauordnung (Bavarian Building Ordinance), Aug 21, 1969, art. 3, [1969] GVBl 263.

43. 1974 Report, *supra* note 3, at 1.

44. These estimates are summarized in Table VII-4 *supra*.

position that government has a moral, as opposed to a legal, responsibility to pay fifty percent of the cost of installation. Owners would pay the remaining fifty percent and could pass on whatever portion they wished to their tenants.

*e. Procurement program.* Since government is a major purchaser of motor vehicles, the fifth ingredient of an effective enforcement strategy is a procurement program. The aim of this procurement program should be to encourage the development and use of low-noise-emission motor vehicles.

Procurement can be dealt with directly or indirectly. The federal government in the United States favors the direct approach, and this approach has been adopted in the Noise Control Act. The Administrator of the Environmental Protection Agency must initially determine within ninety days after receiving an application whether a product qualifies as a low-noise-emission product. He must then determine if the low-noise-emission product is a suitable substitute for a product already being purchased by the federal government. If his determination is affirmative, a one-year certificate is granted to the low-noise-emission product.

At this juncture, responsibility shifts from the Administrator of EPA to the Administrator of General Services. The Administrator of General Services must determine if the procurement costs of the low-noise-emission product are no more than 125% of the retail price of the least expensive product for which the low-noise-emission product is a substitute. If the determination is affirmative, federal agencies are required to purchase the low-noise-emission product. Procurement under this program is subject to several important limitations. An obvious limitation is the 125% requirement.<sup>45</sup> A less obvious limitation is funding. Congress has authorized appropriations to cover the additional expenses associated with purchasing low-noise-emission products, but no funds have actually been appropriated.<sup>46</sup> These two limitations underscore the rather timid approach to procurement taken by the federal government. Given its economic power, this timidity in promoting the development and use of low-noise-emission products is most unfortunate.

---

45. This limitation leaves even more to be desired because it ignores the fact that a significant amount of government procurement is not made from supply lists but is the result of advertised or negotiated procurement. See generally R. NASH & J. CIBINIC, *FEDERAL PROCUREMENT LAW* (3d ed. 1977).

46. The initial delay in funding was occasioned by the fact that final regulations governing the purchase of low-noise-emission products had not been issued. Final regulations were issued on Feb. 21, 1974.



State and local governments have tended to favor the indirect approach.<sup>47</sup> New York City's Noise Control Code, for example, contains two sets of provisions, one dealing with city contracts, the other dealing with product certification. All contracts with New York City must contain the following paragraphs:

1. Devices and activities which will be operated, conducted, constructed, or manufactured pursuant to the contract and which are subject to the provisions of the code will be operated, conducted, constructed or manufactured without causing a violation of the code; and
2. Such devices and activities incorporate advances in the art of noise control developed for the kind and level of noise emitted or produced by such devices and activities.<sup>48</sup>

In addition, the Noise Control Code authorizes the promulgation of regulations for devices and activities involved in city contracts.

Article VII of the Noise Control Code authorizes the creation of an "operating certificate list" for air compressors, paving breakers, refuse-compacting vehicles, and rapid transit railroads. If such a list is created,<sup>49</sup> no operating certificate would be granted unless an applicant can demonstrate that (1) the device can be operated without violating the Noise Control Code and (2) the device incorporates advanced noise abatement technology.

*f. Education program.* An education program is the sixth and last ingredient of an effective enforcement strategy. Many people view noise as an unpleasant but necessary byproduct of urban life. In order to achieve significant noise reductions, this erroneous attitude must be discarded in favor of the attitude that noise "is generally a sign of technical imperfection."<sup>50</sup> Education is the tool that can effect this change in attitude.

New York City's efforts to curb hornhonking, particularly "Q-Day"<sup>51</sup> on March 15, 1956, are instructive from the standpoint

47. The Model State Noise Control Act suggested by The Council of State Governments, however, does provide for procurement of low-noise-emission products, using language very similar to the federal Noise Control Act of 1972. See *Model State Noise Control Act* § 203 in 33 THE COUNCIL OF STATE GOVERNMENTS, 1974 SUGGESTED STATE LEGISLATION 15 (1974).

48. New York City, N.Y., Local Law No. 57, Noise Control Code § 1403.3-2.25(b)(Oct. 4, 1972).

49. No such list has been created nor is it likely that such a list will be created. One New York City official with whom the author spoke described an "operating certificate list" as an "idiotic" idea.

50. Verein Deutscher Ingenieure, VDI-Richtlinien 2058: Beurteilung und Abwehr von Arbeitslärm (Judging and Abating Industrial Noise), at 13 (Jul. 1960).

51. "Quiet Day."

of how to structure an education program. The first lesson Q-Day teaches is that an education program can yield almost immediate results. Q-Day was preceded by a publicity campaign of several months duration and a two-week period during which the police issued warnings to drivers who sounded their horns unnecessarily. According to the *Final Report and Recommendations* issued by the Committee for a Quiet City, the "program was instantly and dramatically successful. Comparative decibel readings at the busiest intersections showed an average decrease in the noise level of 75% . . . ." <sup>52</sup>

The other and perhaps more important lesson Q-Day teaches is that the benefits of such education programs are short term unless the programs are perpetuated. Current residents of New York City probably have never heard of Q-Day and no doubt would be startled to learn that New York City ever tried to curb hornhonking.

The United States has been described as "the land of perpetual noise" by a German writer.<sup>53</sup> Noise is endemic here but need not be. Unlike many other forms of pollution, a significant reduction in noise is possible now with existing technology. State and local governments can and should play an important role in abating noise.

---

52. COMMITTEE FOR A QUIET CITY, FINAL REPORT AND RECOMMENDATIONS 11 (1956).

53. Gunter, *America, the Land of Perpetual Noise*, Washington Post, Jan. 16, 1977, at B7, col. 3.