

## The University of Maine DigitalCommons@UMaine

---

Graduate Student Government Newsletter - The  
Graduate Gazette

Graduate Student Government

---

Spring 2-1-2013

# Graduate Gazette (Graduate Student Newsletter)

Peggy Killian

Radek Glaser

Heather Parry

Cory Robertson

Charles Rodda

*See next page for additional authors*

Follow this and additional works at: [https://digitalcommons.library.umaine.edu/gradstudent\\_news](https://digitalcommons.library.umaine.edu/gradstudent_news)

---

### Repository Citation

Killian, Peggy; Glaser, Radek; Parry, Heather; Robertson, Cory; Rodda, Charles; Hughes, Brianna; and Swatek, Aleksandra, "Graduate Gazette (Graduate Student Newsletter)" (2013). *Graduate Student Government Newsletter - The Graduate Gazette*. 2.  
[https://digitalcommons.library.umaine.edu/gradstudent\\_news/2](https://digitalcommons.library.umaine.edu/gradstudent_news/2)

This Other is brought to you for free and open access by DigitalCommons@UMaine. It has been accepted for inclusion in Graduate Student Government Newsletter - The Graduate Gazette by an authorized administrator of DigitalCommons@UMaine. For more information, please contact [um.library.technical.services@maine.edu](mailto:um.library.technical.services@maine.edu).

---

**Authors**

Peggy Killian, Radek Glaser, Heather Parry, Cory Robertson, Charles Rodda, Brianna Hughes, and Aleksandra Swatek



# Graduate Gazette

## GSG Year in Review

The GSG had an eventful fall semester. We were given informative sessions about the graduate health insurance and the Career Center. We also discussed different social events put on by the GSG and informative workshops to expand your chances for landing that perfect job.

One of the informative sessions the GSG was exposed to was a discussion about the current university health insurance for graduate students. It should be noted that there is a different policy pertaining to graduate students who do not have a graduate, teaching, or research assistantship. With feedback from the GSG last year, and changes on the federal level, the student health plan for 2012/2013 has important differences from 2011/2012. The GA, RA, and TA health insurance is provided by Consolidated Health Plans (CHP) in collaboration with GWH Cigna. This means that your health insurance will cover a visit to anyone in the approved Cigna network (this includes EMMC and Cutler). You can always call CHP customer service and find out if your provider is covered. If you are having problems with the insurance covering health visits, make sure that the provider is coding

everything correctly to maintain proper coverage. Everyone should be aware that there is a front end \$250 deductible for the insurance. This means that you are responsible to pay \$250 to the provider if the service is not a "Preventive Care Expense." Examples of preventive care are women's wellness test, annual physical exams, STD testing, routine vaccines, one eye exam, one dental cleaning and one x-ray. You are more likely to get the preventive care expenses paid without having to pay the deductible if you use a provider in the Cigna network. If you have any questions or feedback about the GA, RA, and TA health insurance or for more information please see our website.

Patty Counihan at the Career Center on campus gave us an info session. The Career Center is underutilized by the graduate students on campus. They typically critique resumes and cover letters, provide mock interviews, and list job openings in your field. You can walk in or make an appointment to have your resume critiqued. Mock interviews are by appointment only. The Career Center also offers the Maine Mentor Program. This program allows for students and alumni to con-

nect for career advice, the program list and database is on the Career Center website. Grad students have access to Careerlink, this allows you to build your resume, search jobs, sign up for career events, and participate in the on-campus recruiting program. The "Going Global" section of career link is where you can look for information about applying for jobs in other countries. The Foster Innovation Center is doing a series Wednesday evenings titled "Real World Preparation" the topics include networking and resumes. There are also plenty of workshops coming up so make sure to keep a lookout!

The GSG has not been all business. We also had many events last semester, these included monthly Woodman's socials, a coffee break at the University Club, and a holiday party at Bear Brew. All of which have been successful and fun. This semester we will continue the Woodman's socials, we'll have another coffee social, the Burritos Board Games Beer and Pac Man is yet to come, and the End-of-Semester Bash! Don't forget the Grad Expo is March 28-29<sup>th</sup>, come check out what your peers have been working on, hope to see you around!

by Heather Parry

## Life After Graduate School: Recent Grads Discuss the Job Search

Post-graduate school plans range from the highly specific to the wide-open. This probably reflects the fact that the reasons for going to graduate school are as varied as the individuals who go—some to find a path, some to hone professional skills, others for artistic or intellectual fulfillment, and many, of course, for a combination of reasons. Sometimes the future can seem illusory, but last year's graduates of the University of Maine's various graduate programs can attest to the many possible routes available and how they went about pursuing the ones they did. Kimberly Brothers, who earned her Ph.D. in Biomedical Sciences in 2012, said she's working in precisely the kind of position she planned to as a postdoctoral associate in the Shanks

lab at the University of Pittsburgh. She studies pathogens that cause eye infections and how to treat them, a pursuit directly related to her graduate work, which can also be classified as infectious disease research. Despite the highly specific nature of her research and career path, Brothers put considerable time and effort into her job search. "I did a lot of networking for my job search," she said, describing a process that included contacting previous coworkers from a job at Dartmouth, following up with people she met at conferences, and even contacting people she'd heard speak at conferences. No surprise that her words of advice to current graduate students are "Network whenever you can."

Sometimes graduate work results in less defined career paths which nonetheless yield results. 2012 graduates of the English M.A. have immersed themselves in a variety of occupations. Choosing one path, though, can be difficult. Assistant Professor of English Charlyse Smith Diaz, who focuses on technical and professional writing, said that graduate students are offered a "smorgasbord" of options, but recommends choosing a path as early on as possible. She, too, emphasizes making professional contacts, and tells the story of a graduate of the program who networked his way to a job after meeting a company owner while out surfing. In the absence of such serendipity, though, graduate students might

(continued on Page 2)

## Upcoming Spring 2013 GSG Meetings

- February 6
- February 27
- March 20
- April 3
- April 17

Meetings are held in the large Stodder Hall conference room, 11:30 am–12:30 pm. All GSG meetings are open and everyone is welcome to attend.

**GradExpo**  
GRADUATE STUDENT EXPOSITION  
**28-29 March 2013**

At the new Innovative Media Research and Commercialization Center

Graduate Students in all disciplines will be competing for thousands of dollars in cash prizes!

Presentation options: Poster, Oral, Electronic, Fine Art and Digital Presentations, Roundtable Discussions and Live Performances

Plus Special Events to be Announced!

Submission guidelines and prize info at: [tinyurl.com/UMaineGradExpo](http://tinyurl.com/UMaineGradExpo)

Electronic submission will open on February 1st

Questions may be directed to: [charlies.rodde@umit.maine.edu](mailto:charlies.rodde@umit.maine.edu) 5755 Stodder Hall 581-4548

**GRANTS: The deadline for Spring 2013 grant applications for both Individual and Clubs & Orgs grants is 4 p.m. on FEBRUARY 8th.**

## Inside this issue:

GSG Year in Review: What We're Doing for You	<b>1</b>
Life After Graduate School: The Job Search	<b>1</b>
GradExpo Invite from Charles Rodda, GSG VP	<b>2</b>
From Macro World to Micro World	<b>2</b>
Council of Grad Schools Annual Meeting	<b>4</b>
International Perspectives Part One	<b>5</b>
International Perspectives Part Two	<b>6</b>

## Life After Graduate School: Recent Grads Discuss the Job Search

(continued from Page 1)

contact likeminded professionals through the Maine Mentor Program, a service of the Career Center that matches students with alumni working in the fields that interest them.

Recent M.A. in English graduate Corey Bean proves that networking right on campus can't hurt, either. "If you're not sure where to look," he said, "there are faculty (probably within a 400 meter radius of where you are right now) who can help." He found work as a grant writer/coordinator for the College of Engineering here on campus, a position he heard about through Professor Diaz, and also works

as a technical writer for the University's Department of Safety, Environmental Management, Transportation, Security, and Wellness.

Personal interactions can take a variety of forms: Wesley McMasters, who teaches English composition at Pennsylvania Highlands Community College and also recently taught at Penn State DuBois, followed up on all of his teaching applications. "When I was hired for the community college," he said, "the Associate Dean of Adjunct Faculty called and remembered speaking with me on the phone. I don't know for sure if that had any impact, but it didn't hurt."

And then there are those with their eye on just one immediate plan. M.A. in English graduate Jacob Kempfert decided early on in his second and final year of the M.A. program to teach English in South Korea. He currently teaches grade 1 (the U.S. equivalent of 7<sup>th</sup> grade) and grade 5 in the city of Gangneung, in the Gangwon province, working through EPIK (English Program in Korea), an organization connected to the Korean Ministry of Education. Kempfert describes his job as rewarding, and while he recommends considering teaching abroad, he also emphasizes the importance of researching teach-abroad options. He explains

that while EPIK provides well for its teachers, some other programs can be exploitative or break contracts.

Kempfert also proves that those more personal or artistic reasons for coming to grad school—for example, to create works of art—can continue in the presence of gainful employment. Skills gained as a graduate teaching assistant are useful in his job seeing 500 students each week, but he hasn't given up creative writing. Works studied in graduate fiction workshops at UMaine, he said, are "key influences in how I am currently crafting my own experiences in Korea as fictive spaces."

### An Invitation from Charles Rodda, GSG Vice President



Hello!

On behalf of the University of Maine Graduate Student Government, I am pleased to invite you to the 2013 UMaine Graduate Student Exposition. Over the course of two days - 28-29 March, 2013 - graduate students from all disciplines are invited to present their research, artistic works, projects and collaborations. In addition to competing for thousands of dollars in cash prizes and recognition for their work, students will be able to interact with representatives from industry and government.

As in years past, the GradExpo will feature disciplinary sessions with poster and oral presentations featuring students in the Physical Sciences & Technology, Natural Sciences, Humanities and Social Sciences. Artists at

the University will be presenting Inter-media art projects, fine art works and performances. The Pecha Kucha competition session challenges students from every discipline to share their work in a rapid-fire slide show lasting under seven minutes.

We are excited to announce that several new interdisciplinary sessions have been added to the GradExpo this year, including sessions on Canadian Studies and The Gulf of Maine. We are also going to feature the winners of the Graduate Life Photo Contest. In addition to the new sessions, we are additionally pleased to be hosting the event in a new venue. GradExpo 2013 will take place in the new Innovative Media Research and Commercialization Center, and will feature an open house to

mark the recent completion of this wonderful facility.

In addition to the academic and artistic exposition we are planning some feature presentations and activities that will appeal to the graduate community and highlight our avocations. We will also be addressed by some of Maine's community leaders.

So mark your calendars, and please watch for activity announcements at: [tinyurl.com/UMaineGradExpo](http://tinyurl.com/UMaineGradExpo). That site also features submission information for graduate students wishing to present at GradExpo 2013.

I hope to see you there!

Charles I. Rodda,  
Vice President, University of Maine  
Graduate Student Government

### From Macro World to Micro World: Interview with Jacob Pelletier, Ph.D. Candidate in Mechanical Engineering

by Radek Glaser

**Q: What brought you to the University of Maine Graduate School for a Master's Degree back in 2003?**

A: In 2003, I was at a point in my academic career where I had just completed my bachelor's degree in Mechanical Engineering here at the University of Maine. In my final year as an undergraduate I chose to take a few graduate level courses and found them to be very satisfying and challenging. My understanding of engineering mechanics became much clearer and I felt that I had a lot more to learn. I also had research interests, such as the

design of composite materials, that were similar to one of my professors who would later become my advisor. I considered him to be a great teacher and a world class researcher at the top of his field. I knew that if I stayed for a master's degree and worked with him, I would learn a lot from him. I did. The graduate school helped make the transition from undergraduate to graduate enrollment easy. Why go west when Maine has everything?

**Q: Can you tell me something about your Master's Degree research?**

A: For my master's thesis I worked on

the analysis and optimal design of composite materials. This included theoretical work on the analysis of two-phase functionally graded materials (FGMs), which are used in high temperature aerospace applications. I also conducted optimization studies on composite laminates, which are also used in both the aerospace and transportation sectors. One highlight of the research was in regards to the optimal design of continuous fiber reinforced composite laminates for maximum strength and stiffness, while at the same time seeking minimum weight. We developed a methodology based on

an integer-coded genetic algorithm that allowed us to simultaneously find optimal designs for these multiple conflicting objectives and constraints. Genetic algorithms were first developed in the 1970's and are essentially a form of simulated evolution where the list of parameters that define a candidate laminate design would be considered a "chromosome". In the computer simulation, different "parent" chromosomes of a given "generation" compete against each other, find mates, reproduce, and mutate in order to generate new and novel "child" designs for the next generation. I applied these tech-

niques to different case studies in order to demonstrate the method and to gain insight into salient problems in mechanical engineering. One case study involved a graphite epoxy cylindrical pressure vessel, such as could be used for hydrogen or compressed air energy storage (see Figure 1). The multi-objective genetic algorithm provided us with a complete design map showing the most optimal configurations under different scenarios. We were able to publish three peer reviewed journal articles from this work.

**Q: What made you decide to return to the University of Maine to pursue a Doctoral Degree in 2009?**

A: My path back to the University of Maine was by no means a straight line. In the four years that passed between finishing my master's degree and then returning back to the University of Maine for doctoral studies, I gained what most would say was practical "life" experience. I saw the cold reality of trying to start a new business in Maine. As a small one-man "nano" entrepreneur, I consulted for a few large and small firms here in Maine on product development, while also working to develop new products on my own in the field of renewable energy. The experience was great and things went very well at first. I also met some very talented, creative, and successful people who mentored me along the way. However, during the economic crisis I was definitely not "too big to fail", and after a poor business decision I did fail. Since I couldn't just print money to keep going I closed up shop. Regardless, the experience was very worthwhile as I feel it gave me a realistic view of innovation in the private sector, rather than the more glamorous view I had as a student. My experiences made me soon realize that, for most companies and individuals in the private sector, innovation and the pursuit of novel ideas is too risky to even dare to attempt. This is not a criticism of those hardworking and talented individuals who comprise Maine's private sector but rather it is a realization of modern economic realities. The general economic and regulatory climate for those in Maine and beyond is too severe regardless of any well intentioned R&D tax incentives or proposals at the state level. While this is only my opinion based on limited observations, it seems that due to a

need for basic survival the business sentiment is one in which there is no risk appetite for tackling "big ideas" that could lead to the next technological revolution like we had in America at the turn of the 20<sup>th</sup> century. In light of this, my hope was that a career in academia could be a perfect fit for me. I think it's still a place where big ideas can be nourished, survive, and maybe help spark the next big economic upswing under the right conditions. Thus with support from my wife, and support from the same great advisor I had for my master's degree, and support from the graduate school, I was able to return to the University of Maine and enrolled full time in the Mechanical Engineering Department's PhD program in the fall of 2009.

**Q: Can you also tell me about your Doctorate research?**

A: My doctoral work covers the analysis and design of complex material systems. In popular language the term "material" is often used in a haphazard way. The average person knows that atoms and molecules are involved in determining how well steel beams hold up a building yet that intuition doesn't really shed light on the geometric complexity that exists between our human length scale and the atomistic. The term *complex material system* refers to a mathematical description for a collection of matter having arbitrary geometric forms; each interacting and responding to environmental stimuli akin to real material systems. All real material systems are complex, most theoretical treatments are not. The *complexity* is proportional to the number of physical phenomena, number of geometric forms, and the span of space and time over which these operate. Since it would be far too costly to model all of the atoms in a steel beam for example, we use these kinds of definitions to make the problems tractable. An example of natural phenomena which we can focus on that meets this definition is that of polycrystalline aggregates or polycrystals. In this case, one observes a collection of single crystals called grains. Most engineering metals are comprised of numerous polycrystalline elements, each having grain sizes on the order of microns which might undergo destructive deformations over the course of a few milliseconds in the case of strong impact forces. In natural materials such

as ice or rock, polycrystalline aggregates are larger, with grains visible to a human eye that can both quickly fracture and have slow fluid-like deformations that occur over millennia. Furthermore, mixing large quantities of different polycrystalline aggregates leads to composite materials, like reinforced concrete for example. When we talk about the properties of a uniform "material", like strength, flexibility, or hardness, we are actually describing emergent behaviors from the evolution of these finer-scale mechanisms and micro-structural elements. Polycrystals are an active field of research and code development by the computational mechanics community. There has also been notable research on linking multiple length and time scales in order to better describe the behavior of large human scale structures and mechanisms. However, such codes are not well suited as general purpose tools for multi-scale engineering design. I seek to model and predict the response of these kinds of materials in a practical manner. We want to be able to attain a quantitative understanding of damage accumulation and durability of polycrystals and then link this information with larger scale mechanisms. This is absolutely critical for our ability to design micro-machines that could be used for more efficient power generation or evolve material microstructures that will improve the

performance, durability, and economy of large scale machines like robots, planes, trains, and automobiles in the future.

**Q: What is the focus of your current research?**

A: Similar to the structure of my master's program, my research tasks have two main branches. They form a combined effort to first develop novel computational methods, and then to use those methods to perform case studies on different material systems. Current work has focused on the development of a fully three-dimensional simulation environment that is capable of dealing with non-linear material mechanics and thermodynamics in computationally efficient manner (see Figure 2). This methodology is intended to enable realistic simulations on workstation class personal computers employing multi-core accelerators. Building the computational tools is where most of the hard work resides, but I need these tools to investigate salient issues in the earth sciences and engineering mechanics. This is the fun part where we are able to generate new scientific understanding. Water ice is a

(continued on Page 4)

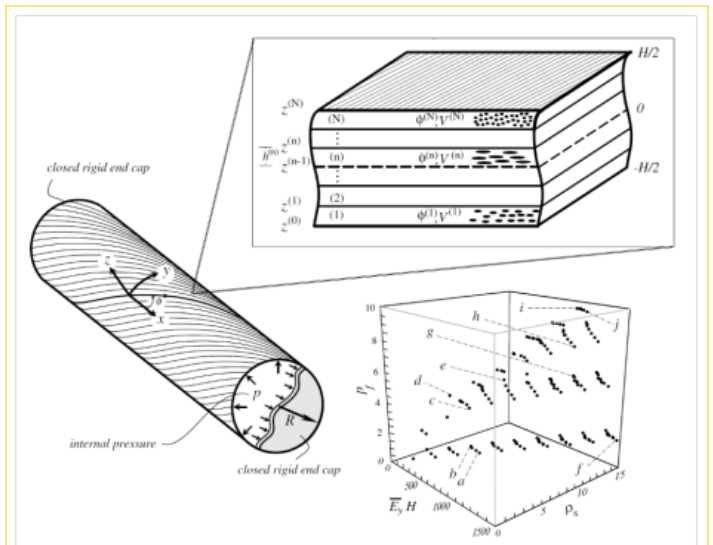

**Figure 1:** The optimization of a laminated composite pressure vessel (a) involved searching for the best fiber volume ratio in each layer, the right number of layers, and the best fiber orientation within each layer (b), in order to minimize the weight while maximizing the strength and rigidity. A multi-objective genetic algorithm used simulated evolution to evolve an optimal population of laminate designs and gives a map of performance (c) based on engineering analysis. There is not a single optimal design because while some designs might be stronger than others, they are also heavier or less rigid. The final population is most evolved and considered to be equally optimal or "pareto-optimal".

**Interview with Jacob Pelletier**

(continued from Page 3)

ubiquitous material on planet earth and was selected as a first investigation due to its unique characteristics and cross-disciplinary popularity with researchers interested in the stability of glaciers. As a second model problem I will investigate micro-engineered metallic foam-like structures that have

the potential for improved energy absorption capabilities. This aims to improve vehicle crash resistance or novel personal protective gear.

**Q: What do you intend to accomplish in your research?**

A: To sum up my earlier statements, I have *three* basic research goals for my doctoral research. These are to contribute to scientific knowledge of damage accumulation in complex

material systems that have either natural or engineered microstructures; to construct novel computational tools to meet goal one; and to demonstrate a simple yet robust computational framework that facilitates the analysis and design of these complex material systems.

**Q: How can the fruits of your hard work contribute to the State of Maine, United States of America, and the World?**

A: That is a rather complex question. As I mentioned earlier, before returning for doctoral studies my work experiences left me with the opinion that we really need to spark an economic boom here in Maine. Rapid technological innovation, combined with commercialization efforts that leads to products that are manufactured *locally* are key to providing this economic recovery. The first products that will spark the recovery will be related to energy or additive manufacturing technologies (3D printing). With this in mind my first wish would be that the computational tools I am working on will either lead to the direct creation of a new manufacturable product in those areas or help others do the same. This software will be released for free via

the internet and I think it will be easy enough to use so that other individuals could develop their own innovations in whatever part of the country or world they reside. In regards to the specific case studies I am investigating: I think that the study of micro-engineered materials, which are made using additive manufacturing processes, could help improve automobile crash resistance and provide widespread benefits. Engineers have made vast improvements to automobiles in the last hundred years. However, automobiles are involved in thirty to forty thousand fatalities and over two million injuries, each and every year. This commonplace facet of modern life is far more dangerous to Americans than any type of firearm in the hands of criminals, or the remote threat of terrorism. Further research and development in technology to improve automobile crash performance would go a long way towards helping people maintain productive lives without injury. It's a popular research area, but I feel that even minor contributions in this area have the potential to do a lot of good.

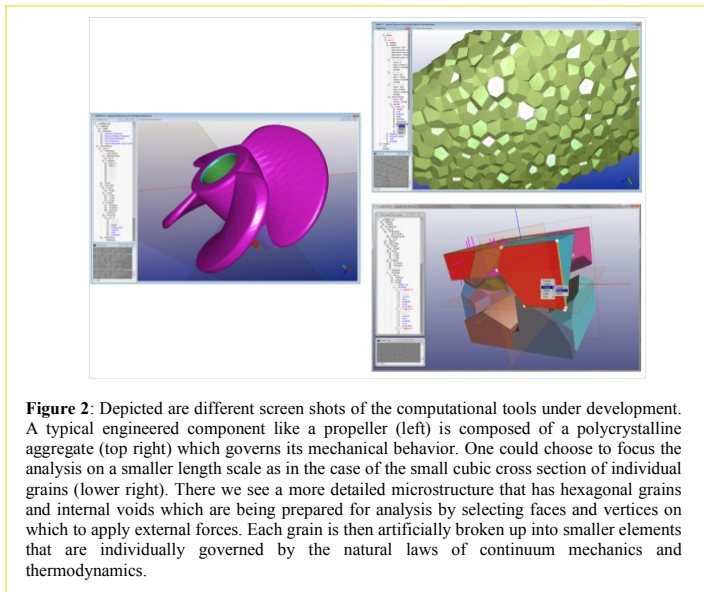

**Figure 2:** Depicted are different screen shots of the computational tools under development. A typical engineered component like a propeller (left) is composed of a polycrystalline aggregate (top right) which governs its mechanical behavior. One could choose to focus the analysis on a smaller length scale as in the case of the small cubic cross section of individual grains (lower right). There we see a more detailed microstructure that has hexagonal grains and internal voids which are being prepared for analysis by selecting faces and vertices on which to apply external forces. Each grain is then artificially broken up into smaller elements that are individually governed by the natural laws of continuum mechanics and thermodynamics.

**2012 Council of Graduate Schools 52<sup>nd</sup> Annual Meeting**

by Brianna Hughes

December 5-8<sup>th</sup> in Washington, D.C. The 52<sup>nd</sup> annual meeting of the Council of Graduate Schools provided an in-depth view of higher education nationwide. Key topics during the meetings I attended were career outcomes, graduate student debt, and the changing culture of higher education. Regarding career outcomes, there was much discussion about the importance of tracking graduate student career progress. It is estimated that 50% of doctoral graduates enter industry, with the other half seeking employment in academia. The number of doctorate-bearing individuals entering the industry is significantly higher than it has been historically, and tracking their career progress would be very useful to better inform current graduate students about career options outside the academy. A common perception among students is that faculty are not encouraging of non-academic or research careers, but when surveyed by the Council of

Graduate Schools, Graduate Deans were split with 1/3 agreeing and 1/3 disagreeing. Many graduate students have a limited understanding of the types of career options that are out there, and yet only 12% of the surveyed students reported using a career center for advice or help finding employment. Almost 50% of the students reported that they sought advice from contacts they had in the industry, 66% sought advice from faculty, and 68% said they also sought advice from their friends and peers. Another question in the survey asked graduate students to identify the top five skills they felt they would need for their career. These skills were 1) oral communication, 2) knowledge of the field, 3) planning and organization, 4) ethics and integrity, and 5) team work. Creating opportunities to develop these skills while in graduate school is paramount to producing successful, competitive graduates. Suggestions to improve career

preparation and outcomes for graduate students were many, but some of the highlights included:

- Strengthening alumni relations
- Improving faculty confidence to deliver advice for non-academic or research positions
- Offering a 0-1 credit career course for graduate students in which faculty with industry experience and outside experts could be brought in to talk with students
- Increase use of campus career centers
- Development of advisory boards specific to graduate students
- Use of social media and e-portfolios to advertise career options for students who do not want to follow a traditional track.

The Graduate Student Government was ahead of the curve with respect to many of these identified needs of graduate students when the position of Outreach and Professional Develop-

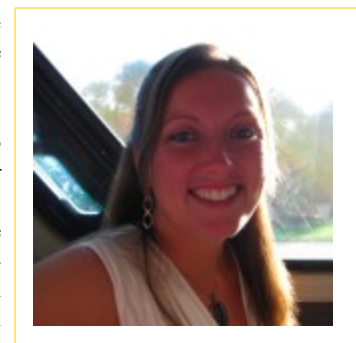

ment Officer was created last year. The OPD Officer has been working very hard to increase awareness of on-campus services for graduate students, to network with the alumni association, and to cooperatively offer job search and networking workshops with the Center for Excellence in Teaching and Assessment (CETA) and the Career Center. We are working very hard to ensure that graduate student needs are anticipated and met, and this concern is shared nationally. (continued)

Another national concern is graduate student debt. There is ~\$1 trillion in aggregated student debt in the United States, and over 2/3 of four year graduates have student debt. What this means for graduate schools everywhere is that more and more of their graduate students are carrying forward undergraduate debt. If deferred, those loans gain interest faster than the students can pay it, even if they are not taking on new debt in graduate school. Additionally, students are almost twice as likely to enroll in graduate school if they have no debt compared to some debt, so in terms of graduate school enrollment undergraduate student debt is very much a concern.

In 2007/2008, 57% of graduate students had debt (up from 49% in 1999/2000), and that percentage is likely even higher today. Financial literacy programs will be critical for helping to curb the massive debts students are racking up before they graduate. The University of Tennessee Chattanooga (UTC) made a terrific presentation highlighting some of their successful programs. One is called "Live Like a Student" which features speakers from the community to cover financial topics such as budgeting, loans, scholarships, investments, and the ever present question of "Are you living cheap enough?" UTC faculty

and staff commonly hear that students want to live like their parents but without the awareness that what they buy now they will pay for later. It was also discussed that many graduate students are supporting families, paying a mortgage, or have other substantial bills that force them to take out loans if they want to stay full-time and finish their degrees. It is recognized that graduate student needs are different from undergraduate needs, but starting financial literacy at a younger age will improve student success no matter which degree they end up pursuing. Some suggestions from UTC for improving financial literacy included:

- Providing salary projections and peer counselors from the Business School to help mentor students
- Conduct programs within dorms so students do not have to go anywhere
- Have a Training and Outreach Officer in Financial Aid and an Assistant Director of Client Services. There was also the suggestion to have a Financial Literacy Coordinator and a Financial Aid Advisor specifically for Graduate Students.
- Seminars and programs run by Greeks, and incorporated into athletics as well.

To conclude, financial stress is a leading cause for students – graduate and undergraduate – to drop out of school.

Implementation of financial literacy programs should begin in orientation and the first year experience – whether through a general education requirement or a freshman seminar type of program. A similar program could be incorporated in graduate schools – particularly since doctoral students can have very high debt simply because of the long time that they are in school. It was also brought up that assistantships are not in line with costs and fees, which is always a concern voiced by students.

Another important discussion that came out of the meeting was the many ways in which higher education is changing. As more people earn graduate degrees, competition for jobs has soared. One suggestion was to begin using "Designated Emphasis" on the diploma to help differentiate students who meet the criteria set by their Graduate School. Some examples included a "Ph.D. in Microbiology with a Designated Emphasis in Biotechnology". It allows demonstration of additional, validated knowledge much as a minor for an undergraduate does. Other thoughts included moving toward more concurrent degree programs such as an MBA/JD program or a PhD/JD. Those types of combinations may open doors to new opportunities that a single degree would not.

Another suggestion was de-emphasizing course requirements so that graduate students would not be required to take as many classes as they are currently. The effect of reducing course requirements would be a more research or experience based degree, development of skills that are valued in the workplace, and faster graduation time.

As a final take-away, graduate education leads to better job opportunities, higher salaries, and greater contributions to society. In the words of John Roberts from ProQuest, "We are not in the education business; we are in the transformation business". The world is always changing, and higher education must change with it. Adaptability and creativity are a must as the needs and demands of students and the workplace change. The coming together of minds at meetings such as the Council of Graduate Schools is a truly singular experience that really sheds light on the many difficulties that campuses are facing across the country, not just here. Working together and sharing resources to improve higher education everywhere is at the heart of what the Council of Graduate Schools does, and it was a phenomenal experience.

## International Perspectives: Two Stories

by Aleksandra Swatek

### Amamihe Onwuachumba

**Q: From all the universities in the world, why did you choose UMaine? How did you learn about our university?**

A: I came to Maine for a cultural exchange program several years back. Here, I became friends with a retired teacher from the Maine area, who recommended continuing my studies at UMaine. I also have to admit, that I was enchanted by the beautiful lakes and scenic mountains of Maine, so I quickly made up my mind to study here.

**Q: What is your field of study and how did you decide that this is what you want to do?**

A: I'm working towards a PhD in Electrical Engineering in the Depart-

ment of Electrical and Computer Engineering. While I was a kid I had access to a bunch of wires, batteries, bulbs, motors and all sorts of electrical stuff we had in the house. It was very fascinating to play with these things. At a time, I built a lighting system in my locker that would turn on when I opened the locker door and turn off when I closed it. This was the moment I realized I should be an electrical engineer.

**Q: Are you working on a particular project?**

A: I am working on smart grid-related projects. My current project is on an analytical tool that will give operators in electric power utilities real-time updates on what is going on in every part of their system and also reduce

(continued on Page 6)





**International Perspectives: Two Stories**

*(continued from Page 5)*

their (utilities) running cost by minimizing the number of equipment needed to be deployed in the field.

**Q: That sounds quite complicated to me, an English graduate. How is this project going to be useful in everyday life of “ordinary” people?**

A: The biggest impact this project will

make on ordinary people is the reduction of electric bills. If the cost of running any business comes down, naturally it should reflect on how much the customers have to pay for the services of that company.

**Q: Now I know how useful it is! I know that UMaine is just another stop on your educational journey. What about your previous educational experiences?**

A: I had my primary and secondary education in Nigeria. I was enrolled in a medical program back there before going to Russia for a BS and MS in Electrical and Electronics Engineering.

**Q: How do you feel now in Maine, coming from so many different places? What do you think about UMaine in general?**

A: Maine was the first place I lived for

a considerable amount of time here in the US. It is gradually becoming home for me. I love the cool summers, and the snow (though I detest the freezing cold). UMaine promotes an atmosphere of academic excellence, personal and professional development, and multicultural appreciation. What I like most about UMaine is that the professors and teachers are very accessible, and the class sizes are relatively small.



**Arnaud Wang-Yang**

**Q: Why did you choose UMaine?**

A: Because I am a Fulbright student, the decision to choose UMaine was guided by the Institute of International Education, which coordinates the Fulbright program on behalf of the U.S. Department of State. UMaine proved to be the best fit for my research interest, although I also got an offer from University of Arkansas – Fayetteville.

**Q: Tell me something about your Fulbright experience. How did you learn about the Fulbright program?**

A: As an undergraduate student I had the opportunity to meet a Fulbright professor from US who was from Washington State University in Pullman, and he talked to us, the students,

about Fulbright scholarship in 2007. I was a student in Nigeria then, and when I graduated I learned more about the Fulbright program. One thing I have learned then was that it was very competitive. After graduation I got a job as a quality control engineer in Baoare Cement Industry, South-west of Chad. So when I started working and the announcement for the Fulbright was published, I wanted to try. I was weary of it. It was an extremely long process, and after I have applied I almost forgot about it. I was working and got used to that, and I wasn't thinking about a change. Finally, I decided I wanted to go back to school when I learned that I got accepted into the program. My Fulbright experience so far is so great; I had a great time during my pre-academic training at the University of Arkansas, Fayetteville. Last year, in October 2012, I partici-

pated in a Fulbright enrichment seminar. I met a lot of people all around the world which I think without Fulbright Program would not have been possible. I had the chance to participate in workshops and share ideas with different presenters and students on the issue of food insecurity. It was beautiful and I have learnt a lot.

**Q: What made you decide to study food Science?**

A: When I was young I wanted to be a medical doctor but could not make it, instead I studied chemical engineering. When I was working as chemical engineering I realized I wasn't fulfilling my childhood dream. I couldn't change the past, go back in time and choose another major. So I decided to do a master in a field that could combine my chemical engineering background and my childhood dream. One of the most important aspects of my new career is to make sure that what people are consuming is safe. So my chemical engineering background proved to be useful in transitioning to the food science program.

**Q: What projects are you going to be working on at UMaine?**

A: A small industry in Portland, Maine is producing alcohol from carrot juice and I will be working to test some of the product elements to see if it fulfills the standards of alcohol for people's consumption.

**Q: Do you plan on going to PhD?**

A: That is my second dream, but at this point I don't know if I would continue with PhD just after finishing the master or wait some years to do it. There are

so many things I will have to take into consideration when making this decision, but I don't know how it is going to turn out. I guess we will have to wait and see.

**Q: How do you like University of Maine?**

A: It is a perfect place for studying; it is a quite campus and we have good food. The department has very good pilot plants for some small scale production and testing of products.

**Q: What can you say about the faculty?**

A: The lecturers put a lot of effort to make sure that I am learning as much as I can. The first semester was tough; I was transition from a different field. For example the microbiology class was really challenging for me. The department has very good lecturers and I am hoping to enjoy the time that I will be there.

**Q: Where are you from originally?**

A: I am from Fianga, a city in the south west of Chad. I grew up in the capital N'djamena where I attended school from primary to high school then did my BA degree at Ahmadu Bello University in Zaria, Nigeria.



<http://www2.umaine.edu/gsg/>