

Cleveland State University  
**EngagedScholarship@CSU**



---

Biological, Geological, and Environmental Faculty Publications      Biological, Geological, and Environmental Sciences Department

---

5-2013

# Differences in Population Structure Estimated Within Maternally- and Paternally-inherited Forms of Mitochondria in *Lampsilis Siliquoidea* (Bivalvia: Unionidae)

Robert A. Krebs

Cleveland State University, [r.krebs@csuohio.edu](mailto:r.krebs@csuohio.edu)

W. Calvin Borden

Loyola University Chicago

Na'tasha M. Evans

Follow this and additional works at: [https://engagedscholarship.csuohio.edu/scibges\\_facpub](https://engagedscholarship.csuohio.edu/scibges_facpub)

 Part of the [Biodiversity Commons](#), [Biology Commons](#), and the [Terrestrial and Aquatic Ecology Commons](#)

F. Paul Doerder  
Cleveland State University, [f.doerder@csuohio.edu](mailto:f.doerder@csuohio.edu)

**How does access to this work benefit you? Let us know!**

## *Publisher's Statement*

This is the accepted version of the following article: Krebs RA, Borden WC, Evans NM, Doerder FP. Differences in population structure estimated within maternally- and paternally-inherited forms of mitochondria in *Lampsilis siliquoidea* (bivalvia: Unionidae). *Biol J Linn Soc* 2013;109(1):229-40. which has been published in final form at <http://onlinelibrary.wiley.com/doi/10.1111/bij.12025/abstract>

---

## Recommended Citation

Krebs RA, Borden WC, Evans NM, Doerder FP. Differences in population structure estimated within maternally- and paternally-inherited forms of mitochondria in *Lampsilis siliquoidea* (bivalvia: Unionidae). *Biol J Linn Soc* 2013;109(1):229-40.

This Article is brought to you for free and open access by the Biological, Geological, and Environmental Sciences Department at EngagedScholarship@CSU. It has been accepted for inclusion in Biological, Geological, and Environmental Faculty Publications by an authorized administrator of EngagedScholarship@CSU. For more information, please contact [library.es@csuohio.edu](mailto:library.es@csuohio.edu).

# Differences in population structure estimated within maternally- and paternally-inherited forms of mitochondria in *Lampsilis siliquoidea* (Bivalvia: Unionidae)

ROBERT A. KREBS<sup>1\*</sup>, W. CALVIN BORDEN<sup>2</sup>, NATASHA M. EVANS<sup>1</sup> and F. PAUL DOERDER<sup>1</sup>

<sup>1</sup>Department of Biological, Geological, and Environmental Sciences, Cleveland State University, Cleveland, OH 44115-2406, USA

<sup>2</sup>Department of Biology, Loyola University Chicago, Chicago, IL 60660, USA

---

Mussels in several orders possess two separate mitochondrial lineages: a standard female-inherited form and one inherited only through males. This system of doubly uniparental inheritance (DUI) for mitochondrial genes provides an opportunity to compare the population structure of gene-lineages passed either mother-to-daughter or father-to-son. In the present study, we contrast variation in the male and female haplotype lineages of the American freshwater mussel species, *Lampsilis siliquoidea* (sometimes called *Lampsilis radiata luteola*), throughout the Lake Erie, Ohio River, and upper Mississippi River watersheds, and contrast variation with the sequences obtained for the related species/subspecies *Lampsilis radiata radiata* from Maine. The genetic markers were fragments of the cytochrome *c* oxidase subunit I gene (COI), which occurs in both mitochondrial types, F (female) and M (male). High haplotype diversity was found in the two independent lineages, although purifying selection against amino acid change appeared to be stronger in the female than the male lineage. Phylogeographical patterns also varied between mitochondria passing through females and males. The female lineage exhibited more population structure, with the occurrence of private or nearly-private haplotypes within two streams, and three others showed restricted haplotype distributions. By contrast to the F-haplotypes, complex phylogenetic structure occurred for M-haplotypes, yet this phylogenetic variation coincided with almost no geographical pattern within haplotypes. Basically, F-haplotypes showed isolation, especially above physical barriers, whereas M-haplotypes did not. A few individuals in the eastern Lake Erie watershed even possessed M-haplotypes of an Atlantic Slope (*L. radiata radiata*) origin, although their F-haplotypes were typical of Midwestern *L. siliquoidea*. The finding that mussels package sperm as spermatozeugmata, which float downstream, may underlie greater gene mobility in male-inherited mitochondria.

ADDITIONAL KEYWORDS: biodiversity – conservation – DUI – freshwater mussels – streams – Unionidae.

---

## INTRODUCTION

Mitochondrial variation (haplotypes) continues to expand in use as a marker in biogeography as sequencing becomes methodologically easier and cheaper for examining variation among populations. The higher mutation rate in mitochondrial than

nuclear genomes combined with a general lack of recombination (Brown, George & Wilson, 1979) enhances opportunities to identify historical connectivity among populations. However, independence among genes on the same mitochondrion is limiting because the whole mitochondrion is essentially one haplotype, and its strict maternal inheritance in most systems and lower effective population size ( $1/4 N_e$ ) means that only the female subset of gene flow events will be observed (Ballard & Rand, 2005; Brown,

---

\*Corresponding author. E-mail: r.krebs@csuohio.edu

2008). Nuclear microsatellites provide the most common alternative for including the contribution of male migration and reproduction in studies of gene flow, although other alternatives exist (e.g. sex-linked markers). Seven families of marine and freshwater bivalves possess another unusual option: a second mitochondrial lineage that passes strictly through males, a pattern called doubly uniparental inheritance (Fisher & Skibinski, 1990; Stewart *et al.*, 1995; Breton *et al.*, 2007). A growing body of evidence implicates this system in sex determination in mussels (Breton *et al.*, 2011).

Within diverse species in the Unionidae and marine mussels of the genus *Mytilus*, the male-inherited mitochondrial form has been receiving considerable attention as a second marker for studying divergence among populations and as a possible test of the role of selection on the mitochondrial genome (King *et al.*, 1999; Roe, Hartfield & Lydeard, 2001; Krebs, 2004; Burdick & White, 2007; Śmietanka, Burzyński & Wenne, 2009; Soroka, 2010; Kijewski *et al.*, 2011). Because the physiological role of this male-inherited form varies from the standard form passed in females (Kenchington *et al.*, 2009; Breton *et al.*, 2011), evolutionary constraints may differ. For example, relaxed levels of selection are considered to contribute to higher polymorphism in the male than the female-inherited mitochondrial (mt)DNA (Hoeh *et al.*, 1996; Liu, Mitton & Wu, 1996; Stewart *et al.*, 1996; Breton *et al.*, 2009; Śmietanka *et al.*, 2009).

Given the different evolutionary pressures on these mitochondrial genomes, variation among these two forms with respect to phylogeographical patterns may be expected, as observed for *Mytilus* where both male and female gametes are released into the water column (Śmietanka *et al.*, 2009; Kijewski *et al.*, 2011). The life cycle of unionid mussels differs from that of marine species, and involves internal fertilization and an obligate parasitic stage on the gills or scales of host fish (Hoggarth, 1999). Larval unionids can therefore disperse upstream (albeit with limits to movement within a river) but not across adjacent watersheds (Berg, Christian & Guttman, 2007; Berg *et al.*, 2008; Schwalb *et al.*, 2011).

The numerous river systems that drain the central plains of the USA and the Atlantic coastal slope together comprise a large heterogeneous environment for freshwater mussels. To examine genetic diversity within this system, common mussel species are better suited for sampling across broad geographical areas, particularly in the context of logistical support and collecting permission from state wildlife agencies. Unionid freshwater mussels are a highly imperiled group in North America and worldwide (Riccardi & Rasmussen, 1999; Lydeard *et al.*, 2004).

In the present study, we chose *Lampsilis siliquoides* (Barnes, 1823) [also known as *Lampsilis radiata luteola*, although we follow the nomenclature of Turgeon *et al.* (1998)] to assess the degree of genetic similarity among populations inhabiting the small tributaries that flow north into Lake Erie from the low Portage Escarpment. This ridge is less than 300 m a.s.l., yet it separates the watersheds of Lake Erie (at 190 m) from the Ohio River watershed. *Lampsilis siliquoides* was almost completely eradicated from Lake Erie (Crail, Krebs & Zanatta, 2011) after invasion of the lake by dreissenid mussels (Schloesser & Nalepa, 1994; Schloesser, Nalepa & Mackie, 1996), although the species occurs in all of the main tributaries of Lake Erie (Krebs *et al.*, 2010; Schwalb *et al.*, 2012) and the Ohio and Mississippi River drainages, which are the proposed historical sources of freshwater mussels to the Great Lakes (Ortmann, 1924; Graf, 2002). Samples from these distant populations, along with samples of *Lampsilis radiata*, which ranges from eastern Canada south along the Atlantic slope (Strayer & Jirka, 1997), provide comparative material to interpret gene flow into the watershed. In the present study, we compare population variation in the maternally-inherited form of a fragment of the cytochrome *c* oxidase subunit I gene (COI) with the paternally-inherited form of the same gene to evaluate the null hypothesis that male and female mitochondria primarily collected from the same individuals will yield similar levels of genetic variation and inferences of population structure.

## MATERIAL AND METHODS

Sequencing focused on populations within the Lake Erie watershed of Northern Ohio with additional sites outside this region (Fig. 1) used to provide phylogeographical context. Sample sizes correspond to female-inherited ( $N = 124$ ) and male-inherited ( $N = 110$ ) mitochondrial haplotypes, respectively, which were obtained from adductor muscle (F-haplotype) and from testes (M-haplotype) of the same male specimens, except where mantle tissue was taken (F-haplotype only). Male-inherited mtDNA in Unionidae is assumed to be restricted to the testes (Liu & Mitton, 1996), although the presence of the male mtDNA across diverse tissues of marine mussels (Garrido-Ramos *et al.*, 1998; Sano, Obata & Komaru, 2007; Obata, Sano & Komaru, 2011) leaves this question open. Genomic DNA from each tissue was purified using the protocol of the Qiagen DNeasy total DNA extraction kit, except that only 1–2 mg of mussel tissue was used in extractions.

Strict collection rules for unionid mussels limited the number of individuals and hence samples obtained from small streams, which, for the Lake Erie

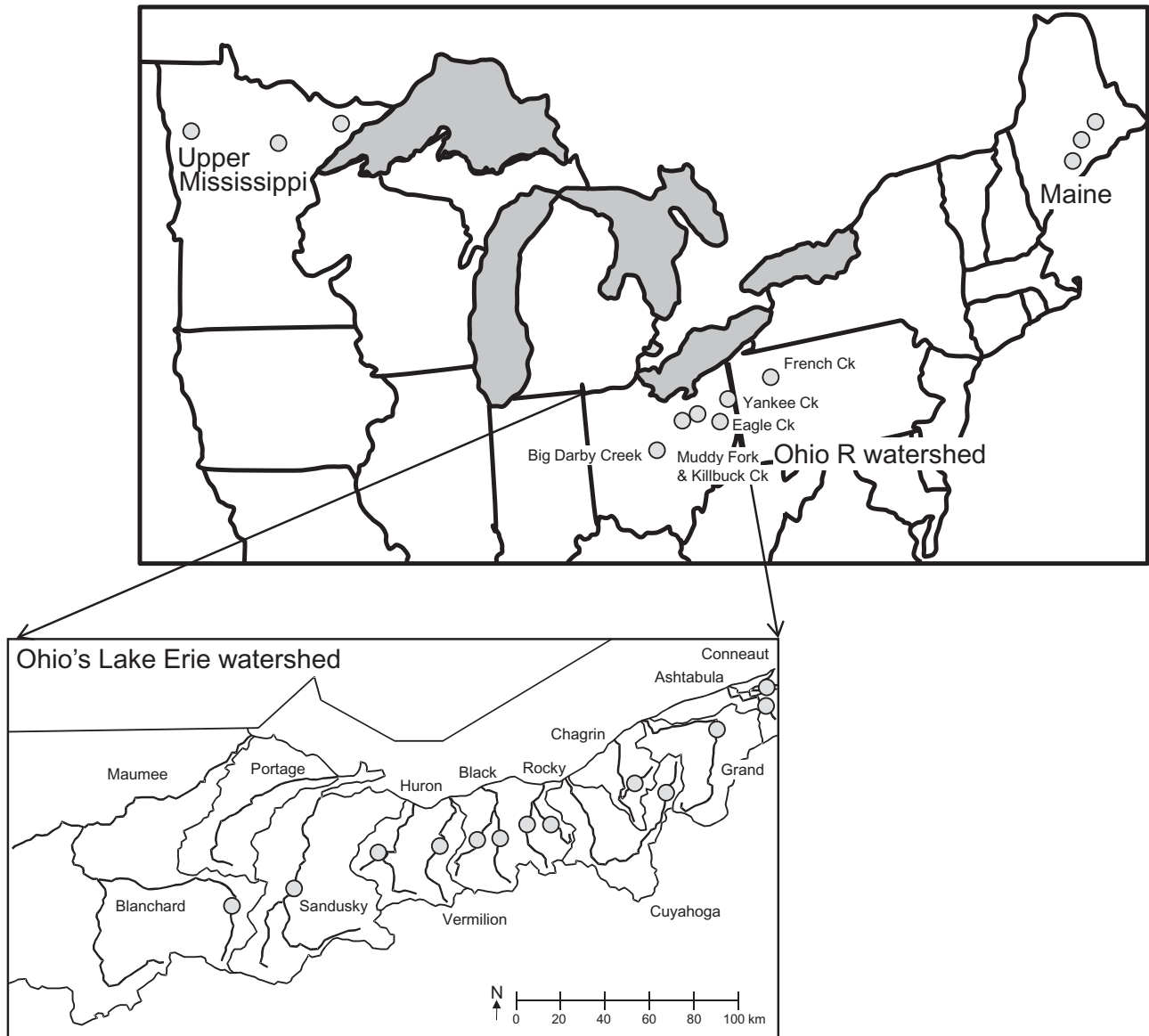

**Figure 1.** Collection sites within Northeastern United States indicating a primary focus on the Lake Erie Watershed (inset), with comparison to sites in the Upper Ohio River watershed, the Upper Mississippi watershed, and populations in coastal rivers of Maine.

watershed in, OH were (F-samples; M-samples): Conneaut Creek (7; 8), Ashtabula River (4; 4), Grand River (4; 7), Chagrin River (15; 13), upper Cuyahoga River (6; 4), Rocky River (7; 3), Black River (13; 16), Vermilion River (4; 4), Huron River (5; 5), Sandusky River (2; 2), and the Blanchard River, a tributary of the Maumee River system (9; 9). Specimens were also obtained from three basins representing possible source populations of Lake Erie haplotypes. Ohio River populations were represented by five tributaries in Ohio and Pennsylvania: Yankee Creek (5; 4), Killbuck Creek (5; 4), Muddy Fork (2; 2), Big Darby Creek

(10; 0, mantle clips only), Eagle Creek (7; 5) and French Creek, PA (1; 2). Upper Mississippi River populations were sampled from several ponds and streams in Minnesota, Red and Roseau Rivers, Isabella and Juggler Lakes (10; 9 in total). Finally, the Atlantic slope was represented by samples from the Sandy, Sebasticook, Passadumkeag and Puhaw Rivers in Maine (8; 9 in total). Mussels from the Lake Erie watershed and those shipped from the upper Mississippi were brought to the laboratory alive; the tissue from each mussel was extracted and placed in 80% ethanol, and stored at  $-20^{\circ}\text{C}$  until use. Other

tissues were either fresh frozen or placed in ethanol in the field during collection. Valves of most specimens were retained and accessioned into the research collection at Cleveland State University.

COI was amplified using primer sets designed for the maternally-inherited and the paternally-inherited form of the locus. The universal primer pair developed by Folmer *et al.* (1994) (LCO1490 5'-GGT CAA CAA ATC ATA AAG ATA TTG G-3'; HCO2198 5'-TTA ACT TCA GGG TGA CCA AAA AAT CA-3') can amplify either form but was applied to adductor or mantle tissue to obtain the female-inherited version of COI. The male-form was amplified using primers LCO1490 and Lamp mHCO (5'-CAA AAC AAA TGT ATA AAA AG-3'). Polymerase chain reaction (PCR) reactions were carried out in 25- $\mu$ L volumes consisting of 10  $\mu$ L of deionized water, 5.5  $\mu$ L of GoTaq buffer, 2.75  $\mu$ L of 2.5 mM dNTPs, 2.75  $\mu$ L of each primer at 2.5 mM, and 2.75  $\mu$ L of 0.25 mM MgCl<sub>2</sub>. To this reaction mix, *Taq* was added in the quantity of 0.15  $\mu$ L per reaction before adding 1  $\mu$ L of DNA template. The initial denaturation phase was 2 min at 94 °C, followed by 35 cycles of DNA denaturation for 30 s, primer annealing at 49 °C for 30 s, and polymerization extension at 72 °C for 45 s.

After amplification, unused primers and dNTPs were degraded using 3  $\mu$ L of a mixture of Exonuclease I (*ExoI*; Amersham Biosciences catalogue number: E70073X, 10 U/ $\mu$ L) and Shrimp Alkaline Phosphatase (SAP; Amersham Biosciences catalogue number: E70092X 1 U/ $\mu$ L) (78  $\mu$ L ddH<sub>2</sub>O, 2  $\mu$ L *ExoI*, 20  $\mu$ L SAP). Reactions were incubated at 37 °C for 40 min followed by 80 °C for 20 min to denature enzymes. Amplicons were sequenced at the Cleveland Clinic. Chromatograms were edited using SEQUENCHER software (GeneCodes Corp.) and aligned using amino acid translation to ensure the absence of stop codons. All samples suggesting an amino acid substitution were repeated to confirm results. No indels were detected; therefore, alignment was trivial. Male and female derived COI sequences were treated as separate haploid loci in all analyses, and we elected not to partition COI by codon position because of the rarity of polymorphic sites in the first and second codon positions, which was expected given the narrow taxonomic scope of the study.

All sequences were entered into DNASP, version 5 (Librado & Rozas, 2009) to define haplotypes from which phylogenetic relationships and haplotype networks were constructed. Data sets were collapsed for duplicate sequences and removed. Unique female ( $N = 28$ ) and male ( $N = 30$ ) haplotypes were 633 bp and 618 bp in length, respectively, as a result of differences in the PCR product. Female and male sequences of four outgroup species (*Actinonaias ligamentina*, *Lampsilis hydiana*, *Lampsilis ovata*, *Lamp-*

*silis straminea*) from Chapman *et al.* (2008) were used to root the trees. Gene trees were constructed using a Bayesian Markov chain Monte Carlo (Drummond *et al.*, 2002) analysis as implemented in MrBayes, version 3.1.2 (Ronquist & Huelsenbeck, 2003). Sequences were analyzed under a GTR + G nucleotide substitution model for both the F and M sequence matrices. Searches were conducted for 20 million generations with six search chains each. One tree was saved every 1000 generations in each analysis. Shape, pinvar, statefreq, and revmat were all unlinked during the analyses, which were terminated when the mean SD of the split frequencies fell below 0.01. The post burn-in trees were used to generate the F and M majority rule consensus trees.

Networks were created in NETWORK, version 4.5.1 (Röhl, 2004) using the median-joining algorithm (Bandelt, Forster & Röhl, 1999) followed by the post-processing Steiner algorithm (Polzin & Daneshmand, 2003) to remove unnecessary median vectors and nonparsimonious links. Polymorphic sites, transitions, and transversions were weighted equally.

## RESULTS

The F-haplotypes and M-haplotypes were very different. Consensus sequences produced from all Midwestern haplotypes showed that 187 of 618 bp (30%) varied between the male and female forms, leading to 67 amino acid substitutions of 206 (32%) coded by this fragment of COI. Therefore F- and M-haplotypes were highly divergent from each other, with variation within each haplotype group completely independent and reciprocally monophyletic (results not shown).

The analysis of 124 female-inherited and 110 male-inherited COI sequences revealed sufficient variation in the *L. radiata* complex to assess divergence among streams (see Table 1). We found 28 unique F-haplotypes varying in 33 of 633 base positions (5%). Haplotypes were connected by single substitutions with only one 'missing' haplotype, suggesting that a large portion of variation in mitochondrial lineages was sampled (i.e. 25 midwestern F-haplotypes). Only two rare mutations substituted an amino acid: valine for isoleucine at nucleotide position 37 and proline for threonine at nucleotide position 547. Both were found only once. By contrast, there were 30 unique M-haplotypes also connected by single substitutions and two 'missing' haplotypes. The sequences varied at 35 of 618 (6%) bases, of which eight mutations (seven found only once) caused an amino acid substitution. A serine-glycine polymorphism as a result of a substitution at nucleotide 139 was common. The difference in the number of nonsynonymous polymorphisms in the F and M

**Table 1.** Maternally and paternally-inherited cytochrome *c* oxidase subunit I gene (COI) haplotypes in the *Lampsilis radiata* complex

Haplotype number	<i>N</i>	Region of occurrence
<b>Maternal</b>		
1	6	Cuyahoga (6)
2	29	Grand (3) Rocky (6), Black (3), Vermilion (2), Huron (3), Sandusky, OR-Big Darby, UM-Isabelle Lake (2), UM-Juggler Lake (3), UM-Red River (5)
3	2	Rocky, Black
4	21	Ashtabula (4), Conneaut (3), Black (4), Vermilion, Blanchard (2), OR-Killbuck Creek (5), OR-Big Darby
5	1	Chagrin
6	1	Black
7	2	Black, Blanchard
8	19	Conneaut (2), Grand, Black (3), Blanchard (4), OR-Big Darby (5), OR-French Creek, OR-Eagle Creek (3)
9	1	Vermilion
10	5	Huron, OR-Yankee Creek (4)
11	1	Huron
12	10	Chagrin (9), OR-Eagle Creek
13	1	Conneaut
14	1	Conneaut
15	1	Sandusky
16	1	Big Darby
17	1	Big Darby
18	5	AS-Maine (5)
19	1	AS-Maine
20	2	AS-Maine (2)
21	1	Blanchard
22	1	Blanchard
23	1	OR-Yankee Creek
24	1	OR-Muddy Fork
25	2	OR-Muddy Fork, OR-Eagle Creek
26	5	Chagrin (5)
27	1	OR-Eagle Creek
28	1	OR-Eagle Creek
<b>Paternal</b>		
1	20	Grand, Chagrin, Rocky (2), Black (5), Vermilion, Huron (2), Sandusky (2), OR-Yankee Creek, OR-Killbuck Creek, OR-Eagle Creek, UM-Isabelle Lake, UM-Red River (2)
2	37	Conneaut Creek (2), Ashtabula, Grand (4), Chagrin (9), Cuyahoga (3), Black (4), Vermilion, Huron (2), Blanchard (3), OR-French Creek (2), OR-Yankee Creek (2) OR-Killbuck Creek (2), OR-Eagle Creek
3	1	Rocky
4	12	Conneaut Creek (2), Grand, Black (2), Vermilion (2), Huron, Blanchard (4),
5	5	Black, UM-Isabelle Lake, UM-Juggler Lake, UM-Red River, OR-Killbuck Creek
6	1	Black
7	1	Black
8	7	Conneaut (2), Chagrin, Black (2), Blanchard, OR-Muddy Fork
9	1	Cuyahoga
10	1	Ashtabula
11	1	Ashtabula
12	1	Ashtabula
13	1	Conneaut
14	1	Chagrin
15	1	Chagrin
16	1	Conneaut
17	1	UM-Red River
18	2	UM-Juggler Lake (2)
19	1	Blanchard
20	1	Grand
21	1	OR-Yankee Creek
22	1	OR-Muddy Fork
23	1	AS-Maine
24	2	AS-Maine (2)
25	1	AS-Maine
26	1	AS-Maine
27	3	AS-Maine (3)
28	1	AS-Maine
29	1	OR-Eagle Creek
30	1	OR-Eagle Creek

Rivers and numbers (where greater than one) are listed east to west within the Lake Erie watershed, followed by the Ohio River watershed (denoted 'OR'), the Upper Mississippi watershed (denoted 'UM'), and Atlantic slope specimens collected in Maine (denoted 'AS').

## A Female haplotypes

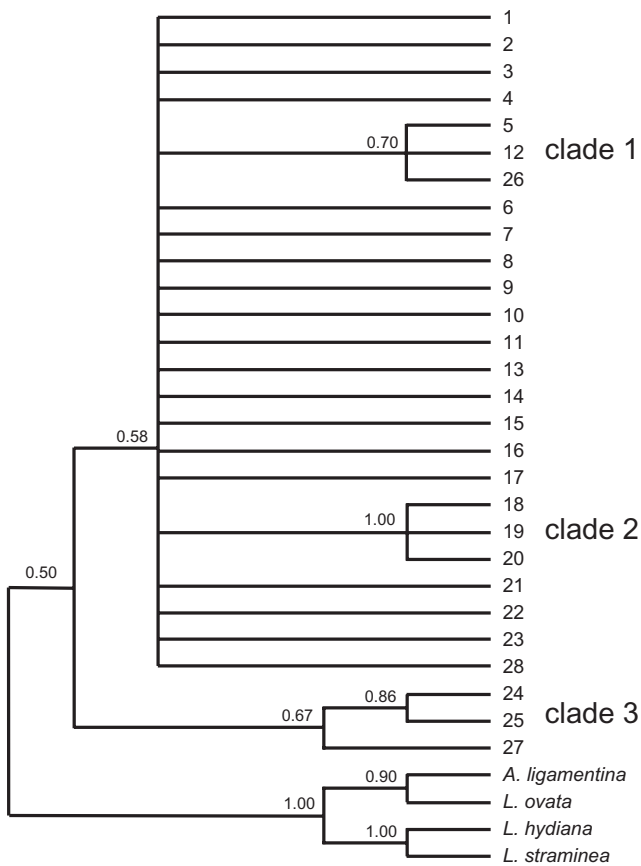

## B Male haplotypes

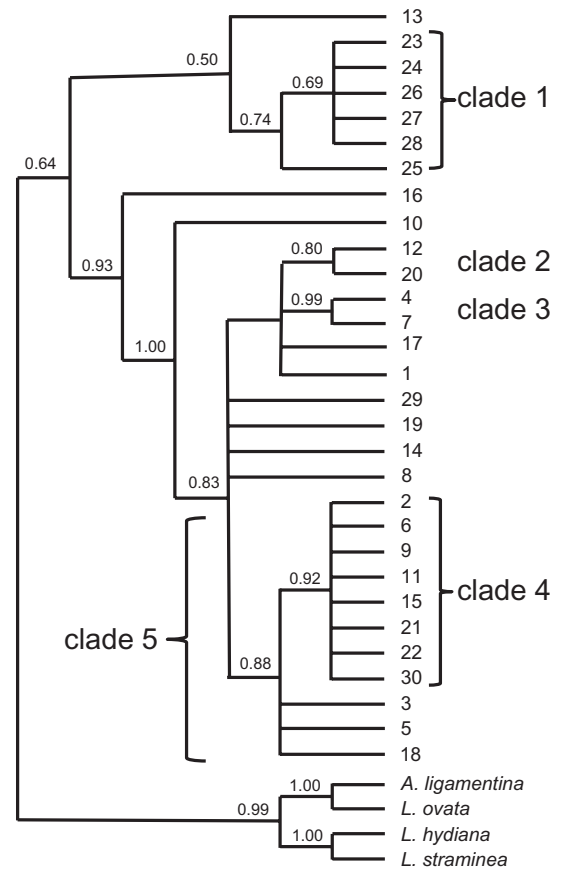

**Figure 2.** Bayesian-inference relationships of (A) 28 maternally-inherited and (B) 30 paternally-inherited cytochrome c oxidase subunit I gene (COI) haplotypes within the *Lampsilis radiata* complex. Sequences were rooted with outgroup species: *Lampsilis straminea*, *Lampsilis hydiana*, *Actinonaias ligamentina* and *Lampsilis ovata* of the respective mitochondrial type. Numbers at nodes denote posterior probabilities >0.50. Notation of clades corresponds to groups demarcated in polygons in the networks (Fig. 3).

mitochondria was sufficient to reject the hypothesis that purifying selection is similar in the male and female mtDNA forms ( $\chi^2 = 3.82$ ,  $P < 0.05$ , one tailed). GenBank Accession numbers are KC408744 to KC408801.

To further test for selection, polymorphisms within species were compared with variation in outgroup species. Among F-haplotypes, one of 30 fixed differences replaced an amino acid, whereas, among M-haplotypes, four of 30 fixed differences substituted an amino acid. A MacDonald–Kreitman test (Hedrick, 2010: 328) gave a fixation index (FI) of 0.53 for the female-inherited COI gene fragment ( $D_N = 1/582$ ,  $P_S = 31/633$ ,  $D_S = 29/582$ ,  $P_N = 2/633$ ), and 0.52 for the male-inherited fragment of the same gene ( $D_N = 4/582$ ,  $P_S = 27/618$ ,  $D_S = 26/582$ ,  $P_N = 8/618$ ). Values less than 1 suggest purifying selection. By this test of selection, the mitochondrial types were similar in

their ratios between substitution and polymorphisms, although, as noted, the number of changes differed markedly.

Gene trees (Fig. 2) and networks (Fig. 3) of 28 unique F-haplotypes and 30 unique M-haplotypes produced phylogenies with short internal branches generally connected by single mutational changes. The one exception was the geographical split between samples from the Atlantic Slope and those from the combined Great Lakes and Mississippi River watersheds. For the Bayesian consensus tree for F-haplotypes (average harmonic mean = -1660.71 and -1658.50 for the two runs; mean tree length = 0.390), the potential scale reduction factor (PSRF) converged on 1.000 from 2001 trees and a single partition of COI. Three distinct genetic haplotype clades were identified in maternally-inherited mitochondria (Fig. 2A and noted as polygons in

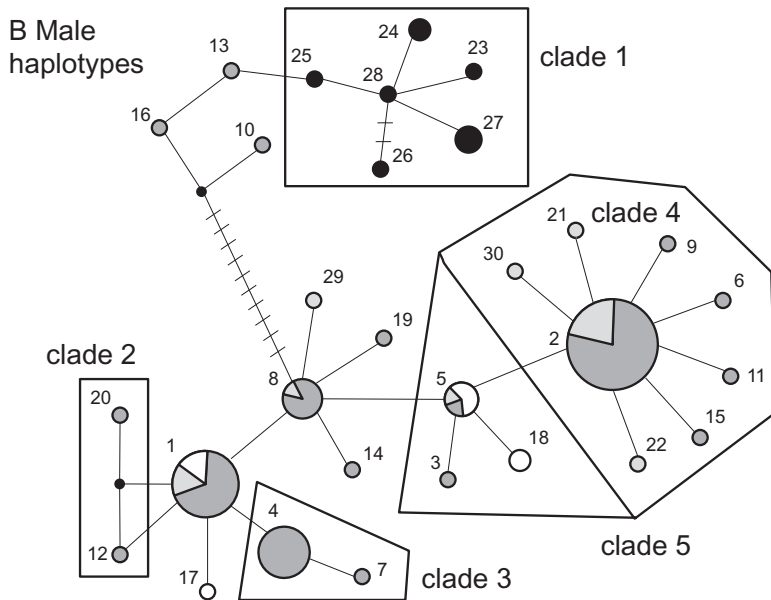
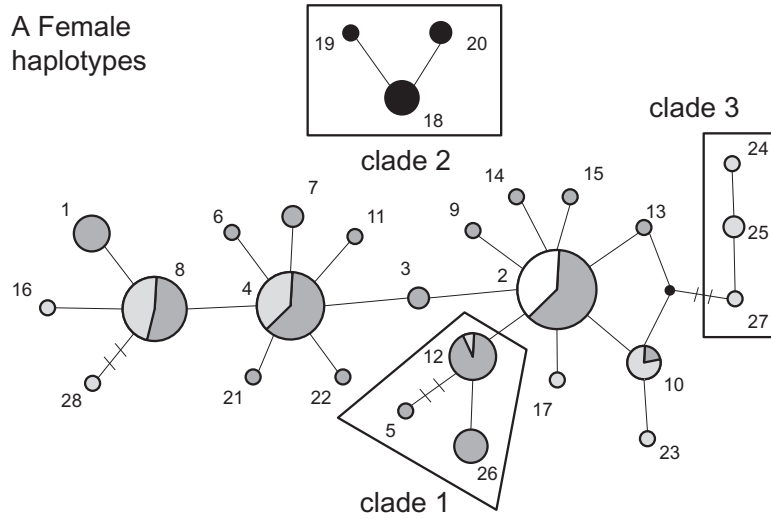

**Figure 3.** Haplotype networks for (A) 28 maternally-inherited and (B) 30 paternally-inherited cytochrome *c* oxidase subunit I gene (COI) haplotypes within the *Lampsilis radiata* complex. Size of circle is proportional to haplotype frequency. Grey-scaling indicates region: black from Maine, dark grey from the Lake Erie watershed, light grey from the Ohio River watershed, and white from the upper Mississippi watershed. The small black dots are missing haplotypes. Notation of clades demarcated in polygons correspond to supported groups in the phylogenies (Fig. 2).

Fig. 3A): moderately supported were clade 1 (with haplotypes 5, 12, 26) and clade 3 (with haplotypes 24, 25, 27), and the only one receiving a prior-probability score of 1.00 was the split called clade 2 of three haplotypes (18, 19, 20) from Maine, putatively *Lampsilis radiata radiata*. The geographical origin of these individuals was suggestive of localized isolation: clade 3 was found only in neighbouring tributaries of the upper Ohio River (four of four individuals), whereas clade 1 predominantly came not just from the Lake

Erie watershed but from the Upper Chagrin River (15 of 16 individuals; Table 1).

Isolation of F-haplotypes therefore occurred at the level of specific streams rather than as an effect of geographical distance. In addition to the isolation of the phylogenetically supported clades, all six individuals from the upper Cuyahoga were haplotype 1; all five from Killbuck Creek were haplotype 4, all five from Yankee Creek were haplotype 10 or the related haplotype 23, and all ten individuals from diverse



sites in Minnesota were haplotype 2. Therefore, a multiallelic  $F_{ST}$  (Halliburton, 2004: 321) was estimated for this locus as 0.30 ( $P < 0.05$ ), based conservatively on just data from streams in the Lake Erie watershed with  $N \geq 5$ .

The male-inherited haplotypes (Fig. 2B) were more phylogenetically diverse. For the Bayesian consensus tree for M-haplotypes (average harmonic mean = -1606.08 and -1604.63 for the two runs; mean tree length = 0.355), the PSRF converged on 1.000. The majority rule consensus tree indicated that all common haplotypes in the network (Fig. 3B) separated with posterior probabilities above 0.80 but in a hierarchical fashion. Clade 1 (note polygon in Fig. 3B) composed the specimens from Maine, putatively *L. radiata radiata*, and haplotypes 10, 13 and 16 were basal to the rest of the putatively *L. siliquoidea* samples. These three haplotypes were collected in two north-eastern Ohio rivers, Ashtabula River and Conneaut Creek, and are related to the Atlantic slope clade (Fig. 3B). Each of these individuals possessed an F-haplotype typical of Ohio individuals (i.e. the Midwestern form). Among individuals from all other clades, for example, clades 2, 3, 4 and 5 (4 is nested within clade 5), geographical separation within M-haplotypes was minimal. Only clade 3, composed of haplotypes 4 and 7, was restricted in distribution and that just to Lake Erie tributaries. Population divergence among streams sampled was not found for M-haplotypes ( $F_{ST} = 0.11$ , not significant).

## DISCUSSION

Because differences exist in the patterns of genetic variation and diversity observed between the F- and M-haplotypes, their combined use provides insights into the evolutionary history of the mitogenome and the biogeographical history of *L. siliquoidea* following de-glaciation. Populations from Lake Erie, as well as the Mississippi and the Ohio River basins, clearly share an evolutionary history, as indicated by their phylogenetic affinities and the very few genetic differences across these watersheds within both the male and female mitochondrial COI lineages. At the watershed level, population structure among rivers is strongly evident in the maternal lineage. This level of variation (i.e. 25 midwestern F-haplotypes) is similar to that of other common species in the region. Elderkin *et al.* (2008) reported 38 haplotypes for *Elliptio dilatata* (25 in the geographical region examined in the present study), although they found more ( $N = 72$ ) for *A. ligamentina*, and Doucet-Beaupré *et al.* (2012) reported over 100 haplotypes among *Pyganodon grandis*, although the study areas only partially overlap. By contrast *Fusconaia flava*, which is widely dispersed but less often very common in this region

(Krebs *et al.*, 2010), had much lower diversity, at just 13 haplotypes (Burdick & White, 2007), and Zanatta & Wilson (2011) focused on microsatellite variation in the federally endangered *Epioblasma triquetra* because mtDNA variation is very low. Across species, high diversity levels in the Great Lakes region likely attest to large population sizes in species that have persisted over time and/or to a large number of colonization routes available (Mandrak & Crossman, 1992) from multiple Mississippian refugia.

After these glaciated regions were colonized, gene flow in *L. siliquoidea* among watersheds appears to have continued based on the combined analysis of the F and M mitochondrial types, although some differences are apparent between the two forms. F-haplotypes revealed substantial isolation in some eastern rivers, most notably populations above large waterfalls as in the Chagrin and Cuyahoga Rivers, and high up in Ohio River tributaries such as the Yankee and Killbuck Creeks. By contrast, all of the relatively lowland tributaries flowing through lake plains in western Lake Erie tended to share the same set of F-haplotypes, a result also Elderkin *et al.* (2008) reported in *E. dilatata* and *A. ligamentina*. Any private alleles in those regions could be explained by the rarity of novel haplotypes, as opposed to genetic isolation of populations.

Few geographical barriers appear to have completely blocked gene flow of M-haplotypes, including the divide between the Atlantic Slope and the Midwestern populations. Migration in *L. siliquoidea* is predicted to follow movement of their centrarchid hosts (Watters, Hoggarth & Stansbery, 2009), of which smallmouth bass (Borden & Krebs, 2009) and largemouth bass (Nedbal & Phillips, 1994) show similar structural patterns of mitochondrial variation to *L. siliquoidea* in the Lake Erie watershed. The female mitochondrial lineage can only move as a zygote, when glochidia attach to fish (Watters, 1992) or potentially float downstream (Schwalb, Garvie & Ackerman, 2010; Culp *et al.*, 2011). Glochidia, of course, transport both maternal and paternal mitochondrial forms. Male-type mitochondria can also move independently downstream before fertilization as spermatozeugmata (sperm balls), which protect sperm for long periods of time (at least 48 h), and may enable significant downstream transport until females capture them within their respiratory current (Ishibashi, Komaru & Kondo, 2000). High fertilization rates from upstream males of *A. ligamentina* are reported to distant females (Moles & Layzer, 2008), a result that Ferguson (2009) suggests as possible in *Lampsilis cardium* and that Krebs (2004) suggests for *P. grandis* based on shared haplotypes spanning geographical barriers. Thus, the relative opportunities of dispersal differ between the F- and M-type

mitochondria, which could be particularly important after headwater capture (the upper Cuyahoga River is one example). Variation in allozymes for *L. siliquoidea* follows the patterns seen in M-haplotypes, with few differences among streams (Berg *et al.*, 2007), and the assessment of both mitochondrial forms allows a more direct measurement of gene flow differences than does shared nuclear markers (Westfall & Gardner, 2010).

An historical side note is that, in some of his last papers, Darwin (1878, 1882) struggled to explain how mussels migrated upstream, although an unusual mode of downstream gene flow may provide the best explanation for divergence in population structure measured as  $F_{ST}$  between standard female-inherited mitochondria and that in the rest of the genome in unionid mussels. M-haplotypes appear to have additional opportunities to move as sperm to downstream females. F movement is restricted to fish patterns. Thus isolated F-haplotypes (but not M-haplotypes) occur above waterfalls and M-haplotypes from the Atlantic slope (but not F-haplotypes) were found in individuals collected in the Lake Erie watershed. No evidence exists that sperm balls cross watershed boundaries, although it is unclear whether anyone has looked for such evidence. Incomplete lineage sorting could account for individuals possessing F-type mitochondria from *L. siliquoidea* and the M-type from *L. radiata*, although greater haplotype variation between the Lake Erie and Atlantic Slope populations would be predicted along with a random presence of Atlantic-slope haplotypes across sampling sites, neither of which our data support.

Possibly, *L. radiata* dispersed westward into Lake Erie and, similar to *Elliptio complanata* (Barber, 1982; Graf, 2002), survived on the fringe of its distributional range. In collections dated around 1904 near the mouth of the Black River, Ohio (by Robert L. Baird, labelled as the Oberlin collection at the Ohio State University Museum of Biological Diversity), specimens are primarily labelled as *L. radiata luteola*, with one notation to a '*siliquoidea*', apparently as a result of heavier pseudocardinal teeth than those labelled *L. radiata luteola*. All specimens that we collect today in the Lake Erie watershed possess this thicker hinge tooth.

Thus, *L. siliquoidea* from the upper Mississippi basin, Lake Erie, and the rivers of Ohio and western Pennsylvania display genetic and ecological differences from *L. radiata*, including variation in host fish (Kneeland & Rhymer, 2008), highlighting their divergent evolutionary histories. Genetic distance between closely-related mussel species tends to be in the range of 2.5% (Roe & Lydeard, 1998), whereas within-species variation is usually less than 1% (Burdick & White, 2007; Elderkin *et al.*, 2008). Midwestern and

Atlantic Slope haplotypes of both the F- and M-types were approximately 1.5% different, similar to F-haplotype variation between *Pyganodon fragilis* and *Pyganodon cataracta* (Doucet-Beaupré *et al.*, 2012) and, within this *Lampsilis* group, hybrid individuals may exist. Therefore, whether one accepts that the western 'radiata' is in fact '*siliquoidea*', or accepts the use of a subspecific declaration, *L. radiata luteola*, *sensu* Watters *et al.* (2009), the two clades possess a close evolutionary history.

#### CONCLUSIONS ON MITOCHONDRIAL EVOLUTION

Within the mussels having doubly uniparental inheritance, selective constraints are assumed to vary between mitochondrial forms (Stewart *et al.*, 1996). For unionids, the male-inherited form may evolve under relaxed selection because it is expressed primarily, if not exclusively, in testes (Quesada, Wenne & Skibinski, 1999; Soroka, 2010; Zbawicka *et al.*, 2010). However, Śmietanka *et al.* (2009) argue that, in *Mytilus*, adaptive evolution also may occur with respect to the male mitochondrial lineage but as a rare occurrence when an F-type mitochondria is picked up in the male lineage. Those events may trigger a selective sweep. They also acknowledge that a rapid postglacial dispersal could produce the same pattern as a selective sweep, a conclusion echoed by Doucet-Beaupré *et al.* (2012) when explaining the co-occurrence of two divergent F-mitogenomes with a single M-mitogenome in the unionid, *Pyganodon lacustris* in the upper Great Lakes region of North American.

Patterns of variation in M-type mitochondria show a remarkable similarity between the Great Lakes unionid fauna and their marine counterparts. Haplotype numbers for the M-type are increased, albeit slightly in *L. siliquoidea*, and this increase may be a result in part to more nonsynonymous polymorphisms; the M- and F-types were more similar in the number of synonymous polymorphisms. A comparison of branch lengths among the unionid species studied for both mitochondrial types supports greater rates of base substitution in the M- than F- mitochondrial forms (Hoeh, Stewart & Guttman, 2002; Krebs, 2004; Breton *et al.*, 2007), which is also concordant with studies in *Mytilus* (Ort & Pogson, 2007; Śmietanka *et al.*, 2009).

For widespread mussel species, whether marine or freshwater, an increased number of polymorphisms in the M-type mitochondria is not accompanied by greater population structure, whether examined at a regional or watershed level. Variation in F-haplotypes is geographically structured more than variation in M-haplotypes, meaning that specific watersheds can be characterized by their F-haplotypes. The relative

contribution of selection and gene flow requires further study because both can sweep a new allele through a region (Addison *et al.*, 2008), especially during initial colonization. In *L. siliquoidea*, homogenization of M-haplotype variation and differences in nonsynonymous substitution frequency suggest a complementarity of migration-selection processes on the evolution of these two mitochondrial forms.

#### ACKNOWLEDGEMENTS

We thank numerous individuals for their contributions to this work. Tissue was provided by Bernard Seitman for material from Minnesota; Chad Ferguson for samples from Big Darby Creek; Judith Rhymer for the animals from Maine; and, locally, Jeremy Holt, John Hook, David Kriska, Mark Lyons, Jeff Pallotta, Louie Rundo, and Erin Steiner all helped collect specimens under permission from the Ohio Department of Natural Resources. We also thank Mara Medeiros for assisting with the DNA extraction and amplification. Dan Graf made numerous suggestions on an earlier version of the manuscript, and three excellent anonymous reviews contributed to the final submission. Financial support included an NSF REU award at Cleveland State University to B. M. Walton and J. Wolin that funded much of the collection work by students; an NOAA NERRS Fellowship supported M. Lyons; and the McNair Program supported N. Evans. Dave Klarer, at the Old Woman Creek National Estuarine Research Reserve, provided use of their facilities.

#### REFERENCES

- Addison JA, Ort BS, Mesa KA, Pogson GH. 2008.** Range-wide genetic homogeneity in the California sea mussel (*Mytilus californianus*): a comparison of allozymes, nuclear DNA markers, and mitochondrial DNA sequences. *Molecular Ecology* **17**: 4222–4232.
- Ballard JWO, Rand DM. 2005.** The population biology of mitochondrial DNA and its phylogenetic implications. *Annual Review of Ecology Evolution and Systematics* **36**: 621–642.
- Bandelt HJ, Forster P, Röhl A. 1999.** Median-joining networks for inferring intraspecific phylogenies. *Molecular Biology and Evolution* **16**: 37–48.
- Barber RJ. 1982.** The indigenous distribution of *Elliptio complanata* in Ohio: archaeological evidence. *Nautilus* **96**: 130–131.
- Berg DJ, Christian AD, Guttman SI. 2007.** Population genetic structure of three freshwater mussel (Unionidae) species within a small stream system: significant variation at local spatial scales. *Freshwater Biology* **52**: 1427–1439.
- Berg DJ, Levine TD, Stoeckel JA, Lang BK. 2008.** A conceptual model linking demography and population genetics of freshwater mussels. *Journal of the North American Benthological Society* **27**: 395–408.
- Borden WC, Krebs RA. 2009.** Phylogeography and postglacial dispersal of smallmouth bass (*Micropterus dolomieu*, Centrarchidae) into the Great Lakes. *Canadian Journal of Fisheries and Aquatic Sciences* **66**: 2142–2156.
- Breton S, Doucet-Beaupré H, Stewart DT, Hoeh WR, Blier PU. 2007.** The unusual system of doubly uniparental inheritance of mtDNA: isn't one enough? *Trends in Genetics* **23**: 465–474.
- Breton S, Doucet-Beaupré H, Stewart DT, Piontkivska H, Karmakar M, Bogan AE, Blier PU, Hoeh WR. 2009.** Comparative mitochondrial genomics of freshwater mussels (Bivalvia: Unionoida) with doubly uniparental inheritance of mtDNA: gender-specific open reading frames and putative origins of replication. *Genetics* **183**: 1575–1589.
- Breton S, Stewart DT, Shepardson S, Trdan RJ, Bogan AE, Chapman EG, Ruminas AJ, Piontkivska H, Hoeh WR. 2011.** Novel protein genes in animal mtDNA: a new sex determination system in freshwater mussels (Bivalvia: Unionoida)? *Molecular Biology and Evolution* **28**: 1645–1659.
- Brown KH. 2008.** Fish mitochondrial genomics: sequence, inheritance and functional variation. *Journal of Fish Biology* **72**: 355–374.
- Brown WM, George MJ, Wilson AC. 1979.** Rapid evolution of animal mitochondrial DNA. *Proceedings of the National Academy of Sciences of the United States of America* **76**: 1967–1971.
- Burdick RC, White MM. 2007.** Phylogeography of the Wabash Pigtoe, *Fusconaia flava* (Rafinesque, 1820) (Bivalvia: Unionidae). *Journal of Molluscan Studies* **73**: 367–375.
- Chapman EG, Gordon ME, Walker JM, Lang BK, Campbell DC, Watters GT, Curole JP, Piontkivska H, Hoeh WR. 2008.** Evolutionary relationships of *Popenaias popeii* and the early evolution of Lampsiline bivalves (Unionidae): phylogenetic analyses of DNA and amino acid sequences from F and M mitochondrial genomes. *Malacologia* **50**: 303–318.
- Crail TD, Krebs RA, Zanatta DT. 2011.** Unionid mussels from nearshore zones of Lake Erie. *Journal of Great Lakes Research* **37**: 199–202.
- Culp JJ, Haag WR, Arrington DA, Kennedy TB. 2011.** Seasonal and species specific patterns in abundance of freshwater mussel glochidia in stream drift. *Journal of the North American Benthological Society* **30**: 436–445.
- Darwin C. 1878.** Transplantation of shells. *Nature* **18**: 120–121.
- Darwin C. 1882.** On the distribution of freshwater bivalves. *Nature* **25**: 529–530.
- Doucet-Beaupré H, Blier PU, Chapman EG, Piontkivska H, Dufresne F, Sietman BE, Mulcrone RS, Hoeh WR. 2012.** *Pyganodon* (Bivalvia: Unionoida: Unionidae) phylogenetics: a male- and female-transmitted mitochondrial DNA perspective. *Molecular Phylogenetics and Evolution* **63**: 430–444.

- Drummond AJ, Nicholls GK, Rodrigo AG, Solomon W. 2002.** Estimating mutation parameters, population history and genealogy simultaneously from temporally spaced sequence data. *Genetics* **161**: 1307–1320.
- Elderkin CL, Christian AD, Metcalfe-Smith JL, Berg DJ. 2008.** Population genetics and phylogeography of freshwater mussels in North America, *Elliptio dilatata* and *Actinonaias ligamentina* (Bivalvia: Unionidae). *Molecular Ecology* **17**: 2149–2163.
- Ferguson CD. 2009.** Conservation genetics of a near threatened freshwater mussel species (*Lampsilis cardium*) and improved prospects for recovery: how nuclear and mitochondrial DNA analyses inform natural history and conservation. PhD Thesis, Wright State University.
- Fisher C, Skibinski DOF. 1990.** Sex-biased mitochondrial DNA heteroplasmy in the marine mussel *Mytilus*. *Proceedings of the Royal Society of London Series B, Biological Sciences* **242**: 149–156.
- Folmer O, Black MB, Hoeh WR, Lutz R, Vrijenhoek RL. 1994.** DNA primers for amplification of mitochondrial cytochrome c oxidase subunit I from diverse metazoan invertebrates. *Molecular Marine Biology and Biotechnology* **3**: 294–299.
- Garrido-Ramos MA, Stewart DT, Sutherland BW, Zouros E. 1998.** The distribution of male-transmitted and female-transmitted mitochondrial DNA types in somatic tissues of blue mussels: implications for the operation of doubly uniparental inheritance of mitochondrial DNA. *Genome* **41**: 818–824.
- Graf DL. 2002.** Historical biogeography and late glacial origin of the freshwater pearly mussel (Bivalvia: Unionidae) faunas of Lake Erie, North America. *Museum of Comparative Zoology – Occasional Papers on Mollusks* **6**: 175–210.
- Halliburton R. 2004.** *Introduction to population genetics*. New Brunswick, NJ: Pearson Press.
- Hedrick PW. 2010.** *Genetics of populations*. Sudbury, MA: Jones and Bartlett Publishers.
- Hoeh WR, Stewart DT, Guttman SI. 2002.** High fidelity of mitochondrial genome transmission under the doubly uniparental mode of inheritance in freshwater mussels (Bivalvia: Unionidae). *Evolution* **56**: 2252–2261.
- Hoeh WR, Stewart DT, Sutherland BW, Zouros E. 1996.** Cytochrome c oxidase sequence comparisons suggest an unusually high rate of mitochondrial DNA evolution in *Mytilus* (Mollusca: Bivalvia). *Molecular Biology and Evolution* **13**: 418–421.
- Hoggarth MA. 1999.** Descriptions of some of the glochidia of the Unionidae (Mollusca : Bivalvia). *Malacologia* **41**: 1–118.
- Ishibashi R, Komaru A, Kondo T. 2000.** Sperm sphere in unionid mussels (Bivalvia: Unionidae). *Zoological Science* **17**: 947–950.
- Kenchington EL, Hamilton L, Cogswell A, Zouros E. 2009.** Paternal mtDNA and maleness are co-inherited but not causally linked in mytilid mussels. *PLoS ONE* **4**: e6976.
- Kijewski T, Śmietanka B, Zbawicka M, Gosling E, Hummel WH. 2011.** Distribution of *Mytilus* taxa in European coastal areas as inferred from molecular markers. *Journal of Sea Research* **65**: 224–234.
- King TL, Eackles MS, Gjetvaj B, Hoeh WR. 1999.** Intraspecific phylogeography of *Lampsilis subviridis* (Bivalvia: Unionidae): conservation implications and range discontinuity. *Molecular Ecology* **8**: S65–S78.
- Kneeland SC, Rhymer JM. 2008.** Determination of fish host use by wild populations of rare freshwater mussels using a molecular identification key to identify glochidia. *Journal of the North American Benthological Society* **27**: 150–160.
- Krebs RA. 2004.** Combining paternally and maternally inherited mitochondrial DNA for analysis of population structure in mussels. *Molecular Ecology* **13**: 1701–1705.
- Krebs RA, Borden WC, Steiner ER, Lyons MS, Zawiski W, Walton BM. 2010.** Determinants of mussel diversity in Lake Erie tributaries. *Journal of the North American Benthological Society* **29**: 506–520.
- Librado P, Rozas J. 2009.** DnaSP v5: a software for comprehensive analysis of DNA polymorphism data. *Bioinformatics* **25**: 1451–1452.
- Liu HP, Mitton JB. 1996.** Tissue-specific maternal and paternal mitochondrial DNA in the freshwater mussel, *Anodonta grandis grandis*. *Journal of Molluscan Studies* **62**: 393–394.
- Liu HP, Mitton JB, Wu SK. 1996.** Paternal mitochondrial DNA differentiation far exceeds maternal mitochondrial DNA and allozyme differentiation in the freshwater mussel, *Anodonta grandis grandis*. *Evolution* **50**: 952–957.
- Lydeard C, Cowie RH, Bogan AE, Bouchet P, Cumming KS, Gargominy O, Herbert DG, Hershler R, Perez KE, Roth B, Seddon M, Strong EE, Thompson FG. 2004.** The global decline of nonmarine mollusks. *Bioscience* **54**: 321–330.
- Mandrak NE, Crossman EJ. 1992.** Postglacial dispersal of freshwater fishes into Ontario. *Canadian Journal of Zoology – Revue Canadienne de Zoologie* **70**: 2247–2259.
- Moles KR, Layzer JB. 2008.** Reproductive ecology of *Actinonaias ligamentina* (Bivalvia : Unionidae) in a regulated river. *Journal of the North American Benthological Society* **27**: 212–222.
- Nedbal MA, Phillips DP. 1994.** Differentiation of mitochondrial DNA in largemouth bass. *Transactions of the American Fisheries Society* **123**: 460–468.
- Obata M, Sano N, Komaru A. 2011.** Different transcriptional ratios of male and female transmitted mitochondrial DNA and tissue-specific expression patterns in the blue mussel, *Mytilus galloprovincialis*. *Development Growth & Differentiation* **53**: 878–886.
- Ort BS, Pogson GH. 2007.** Molecular population genetics of the male and female mitochondrial DNA molecules of the California sea mussel, *Mytilus californianus*. *Genetics* **177**: 1087–1099.
- Ortmann AE. 1924.** Distributional features of naiads in tributaries of Lake Erie. *American Midland Naturalist* **9**: 101–117.
- Polzin T, Daneshmand SV. 2003.** On Steiner trees and minimum spanning trees in hypergraphs. *Operations Research Letters* **31**: 12–20.
- Quesada H, Wenne R, Skibinski DOF. 1999.** Interspecific

- transfer of female mitochondrial DNA is coupled with role-reversals and departure from neutrality in the mussel *Mytilus trossulus*. *Molecular Biology and Evolution* **16**: 655–665.
- Riccardi A, Rasmussen JB. 1999.** Extinction rates of North American freshwater fauna. *Conservation Biology* **13**: 1220–1222.
- Roe KJ, Hartfield PD, Lydeard C. 2001.** Phylogeographic analysis of the threatened and endangered superconglutinate-producing mussels of the genus *Lampsilis* (Bivalvia: Unionidae). *Molecular Ecology* **10**: 2225–2234.
- Roe KJ, Lydeard C. 1998.** Molecular systematics of the freshwater mussel genus *Potamilus* (Bivalvia: Unionidae). *Malacologia* **39**: 195–205.
- Röhl A. 2004.** NETWORK, version 4.5.1.0. Shareware Phylogenetic Network Software presented by Fluxus Technology Ltd. Available at: <http://www.fluxus-engineering.com>
- Ronquist F, Huelsenbeck JP. 2003.** MrBayes 3: bayesian phylogenetic inference under mixed models. *Bioinformatics* **19**: 1572–1574.
- Sano N, Obata M, Komaru A. 2007.** Quantitation of the male and female types of mitochondrial DNA in a blue mussel, *Mytilus galloprovincialis*, using real-time polymerase chain reaction assay. *Development Growth & Differentiation* **49**: 67–72.
- Schloesser DW, Nalepa T. 1994.** Dramatic decline of unionid bivalves in offshore waters of western Lake Erie after the invasion by zebra mussels, *Dreissena polymorpha*. *Canadian Journal of Fisheries and Aquatic Sciences* **51**: 2234–2242.
- Schloesser DW, Nalepa T, Mackie G. 1996.** Zebra mussel infestation of unionid bivalves (Unionidae) in North America. *American Zoologist* **36**: 300–310.
- Schwab AN, Cottenie K, Poos MS, Ackerman JD. 2011.** Dispersal limitation of unionid mussels and implications for their conservation. *Freshwater Biology* **56**: 1509–1518.
- Schwab AN, Garvie M, Ackerman JD. 2010.** Dispersion of freshwater mussel larvae in a lowland river. *Limnology and Oceanography* **55**: 628–638.
- Schwab AN, Morris TJ, Mandrak NE, Cottenie K. 2012.** Distribution of unionid freshwater mussels depends on the distribution of host fishes on a regional scale. *Diversity and Distributions*. doi: 10.1111/j.1472-4642.2012.00940.x.
- Śmietanka B, Burzyński A, Wenne R. 2009.** Molecular population genetics of male and female mitochondrial genomes in European mussels *Mytilus*. *Marine Biology* **156**: 913–925.
- Soroka M. 2010.** Characteristics of mitochondrial DNA of unionid bivalves (Mollusca: Bivalvia: Unionidae). I. Detection and characteristics of doubly uniparental inheritance (DUI) of unionid mitochondrial DNA. *Folia Malacologica* **18**: 147–188.
- Stewart DT, Kenchington ER, Singh RK, Zouros E. 1996.** Degree of selective constraint as an explanation of the different rates of evolution of gender-specific mitochondrial DNA lineages in the mussel *Mytilus*. *Genetics* **143**: 1349–1357.
- Stewart DT, Saavedra C, Stanwood RR, Ball AO, Zouros E. 1995.** Male and female mitochondrial-DNA lineages in the blue mussel (*Mytilus edulus*) species group. *Molecular Biology and Evolution* **12**: 735–747.
- Strayer DL, Jirka KJ. 1997.** *The pearly mussels of New York State*. New York State Museum Memoir 26. Albany, NY: New York State Museum.
- Turgeon DD, Quinn JF Jr, Bogan AE, Coan EV, Hochberg FG, Lyons WG, Mikkelsen PM, Neves RJ, Roper CFE, Rosenberg G, Roth B, Scheltema A, Thompson FG, Vecchione M, Williams JD. 1998.** *Common and scientific names of aquatic invertebrates from the United States and Canada: mollusks*, 2nd edn. Bethesda, MD: American Fisheries Society.
- Watters GT. 1992.** Unionids, fishes, and the species-area curve. *Journal of Biogeography* **19**: 481–490.
- Watters GT, Hoggarth MA, Stansbery DH. 2009.** *The freshwater mussels of Ohio*. Columbus, OH: The Ohio State University Press.
- Westfall KM, Gardner JPA. 2010.** Genetic diversity of Southern hemisphere blue mussels (Bivalvia: Mytilidae) and the identification of non-indigenous taxa. *Biological Journal of the Linnean Society* **101**: 898–909.
- Zanatta DT, Wilson CC. 2011.** Testing congruency of geographic and genetic structure for a freshwater mussel (Bivalvia: Unionida) and its host fish. *Biological Journal of the Linnean Society* **102**: 669–685.
- Zbawicka M, Burzyński A, Skibinski D, Wenne R. 2010.** Scottish *Mytilus* mussels retain ancestral mitochondrial DNA: complete sequences of male and female mtDNA genomes. *Gene* **456**: 45–53.