

2011

# Intricate RNA : RNA Interactions in U12-Dependent Nuclear Pre-mRNA Splicing

Tupa Basu Roy  
*Cleveland State University*

Follow this and additional works at: <https://engagedscholarship.csuohio.edu/etdarchive>

 Part of the [Biology Commons](#)

**How does access to this work benefit you? Let us know!**

---

## Recommended Citation

Basu Roy, Tupa, "Intricate RNA : RNA Interactions in U12-Dependent Nuclear Pre-mRNA Splicing" (2011). *ETD Archive*. 675.  
<https://engagedscholarship.csuohio.edu/etdarchive/675>

This Thesis is brought to you for free and open access by EngagedScholarship@CSU. It has been accepted for inclusion in ETD Archive by an authorized administrator of EngagedScholarship@CSU. For more information, please contact [library.es@csuohio.edu](mailto:library.es@csuohio.edu).

**INTRICATE RNA: RNA INTERACTIONS IN U12-DEPENDENT NUCLEAR  
PRE- mRNA SPLICING**

**TUPA BASU ROY**

Master of Science in Zoology

University of Calcutta

December, 2000

Submitted in partial fulfillment of requirements for the degree

**MASTER OF SCIENCE IN BIOLOGY**

At the

**CLEVELAND STATE UNIVERSITY**

December, 2011

This thesis has been approved for  
The Department of Biological, Geological and Environmental Sciences (Regulatory  
Biology: Clinical and Molecular Medicine Specialization) and for the  
College of Graduate Studies of Cleveland State University

by

\_\_\_\_\_ Date: \_\_\_\_\_  
Girish Shukla, Ph.D., BGES, CSU  
Major Advisor, Committee Chairperson

\_\_\_\_\_ Date: \_\_\_\_\_  
Anton A. Komar, Ph.D., BGES, CSU  
Program Director, Advisory Committee Member

\_\_\_\_\_ Date: \_\_\_\_\_  
Barsanjit Mazumder, Ph.D., BGES, CSU  
Advisory Committee Member

## ACKNOWLEDGEMENTS

First of all, I would like to thank the Almighty for all blessings without which nothing would have been possible.

I have embarked and started my research with the prior teaching, sage advice, insightful criticisms and patient encouragement of my mentor and guide, Dr. Girish Shukla, who has provided me an opportunity to conduct my research and has strongly contributed to the completion of this thesis.

I would like to record my gratitude to Dr. Anton A. Komar and Dr. Barsanjit Mazumder for their valuable advice and guidance from the beginning of my graduate career and during my course-work at Cleveland State University. Their teaching opened up unknown horizons to me. Also, I am thankful that, in the midst of their tight schedule, they have accepted to be members of my advisory committee.

I convey special acknowledgement to Dr. Jeffrey Dean and Dr. Crystal Weyman for their indispensable help and support through the Graduate Teaching Assistantship.

I would also like to extend thanks to Dr. Richard A. Padgett and Ms. Rosemary C. Dietrich for their support while performing the *in vivo* splicing assay in Lerner Research Institute, Cleveland Clinic Foundation, Ohio.

I gratefully acknowledge Dr. Kavleen Sikand for her valuable guidelines in science discussion. I am proud to make a special reference to my colleague, Jinani, whose updates helped me with opportunities to attend several interschool science fairs, including NEOSEF as well as CONSEF, as a science fair judge.

I have worked with great number of people to whom I send a collective and individual acknowledgment: Neha, Kevin, Megan, Giovanna and India. In addition to my lab colleagues, whose presence perpetually was refreshing, helpful and memorable, I convey my gratitude to all members of the BGES Department, Cleveland State University, for giving me such a pleasant time. Their love kept me going.

This thesis is dedicated to my father, Debabrata Basu Roy and my mother, Papri Basu Roy. You have raised me with caring and gentle love and have implemented the fundamentals of my learning character, showing me the joy of intellectual pursuit, ever since I was a child. Your words are a source of inspiration to me and I reach where I stand today.

**INTRICATE RNA: RNA INTERACTIONS IN U12-DEPENDENT NUCLEAR  
PRE- mRNA SPLICING**

**TUPA BASU ROY**

**ABSTRACT**

Coding regions or exons of most human genes are interrupted by noncoding intervening regions or introns. Removal of nuclear precursor messenger RNA (pre-mRNA) introns by RNA splicing is an essential step in eukaryotic gene expression. Two types of nuclear pre-mRNA introns are known as U2-dependent or major type and U12-dependent or minor type. Nuclear pre-mRNA introns are removed by two distinct sets of ribonucleoprotein complexes or spliceosomes, which are formed by five small nuclear RNAs (snRNAs) for each spliceosome. U6atac and U12 snRNAs are central to U12-dependent spliceosome and play essential roles in the removal of U12-dependent introns. U6atac and U12 snRNAs bind to the 5' splice site and branch site, respectively of an U12-dependent intron. In addition, it has been predicted that, U6atac and U12 snRNAs interact inter-molecularly to form helix I structure, which appears to be an essential element of the minor spliceosome. We have been studying U6atac and U12 inter-molecular base-pairing interaction using an *in vivo* mutation suppression assay. In this study, we have characterized U6atac and U12 mediated helix I intermolecular interactions and have shown *in vivo* existence of the predicted structure. In addition, we have also identified a region of U6atac snRNA which appears to be a structural

analog of U12 snRNA stem III element. This element is important for the function of U12 snRNA and functions by binding to a RNA binding 65K protein, which is unique to minor spliceosome. We show that, analogous stem-loop of U6atac snRNA also interacts with 65K - RNA binding protein. However, functional significance of this interaction remained unclear. In summation, we have characterized sequential and dynamic RNA-RNA interactions between U4atac-U6atac and U6atac-U12 snRNAs. Our data show that, extensive and obligatory RNA-RNA interactions are critical to the splicing of U12-dependent introns.

## TABLE OF CONTENTS

ABSTRACT.....	V
LIST OF FIGURES .....	XI
LIST OF TABLES.....	XII
LIST OF ABBREVIATIONS.....	XIII
CHAPTERS	
I. INTRODUCTION	
1.1. Mechanism of Gene Expression.....	1
1.2. Eukaryotic Pre-mRNA Processing .....	2
1.3. Biochemical Pathway of Spliceosomal Splicing .....	3
1.4. Introduction of Introns into Eukaryotic Genomes .....	3
1.5. Spliceosomal Introns.....	5
1.6. Splicing Fidelity .....	6
1.7. Major Spliceosomal Components and Their Biogenesis.....	7
1.8. Minor Spliceosomal Components and Their Biogenesis .....	10
1.9. Catalytic Reactions During Splicing .....	11
1.10. U2-type / Major Spliceosomal Assembly and Dis-assembly....	13
1.11. U12-type / Minor Spliceosomal Assembly and Dis-assembly.....	15



1.12. Dynamic RNA-RNA Interactions in Helices of Spliceosomal snRNA.....	15
1.13. Homologous RNA Elements in Catalytic Triad .....	16
1.14. Conserved RNA Elements among Divergent Eukaryotic Lineages .....	17
1.15. Evolutionary History of the Two Spliceosomes.....	17
1.16. Significance of Study of Minor Spliceosomes.....	20

## II. MATERIALS AND METHODS

2.1. Mutant Construction .....	22
2.2. <i>In vivo</i> Genetic Suppression Assay .....	24
2.3. CHO Cell Maintenance and Transfection .....	25
2.4. Total RNA Isolation .....	26
2.5. Reverse Transcriptase- Polymerase Chain Reaction (RT-PCR) .....	27
2.6. Nested PCR .....	27
2.7. <i>In vitro</i> Transcription .....	28
2.8. GST-FP (GST- Fusion Protein) Expression .....	29
2.9. GST-FP (GST- Fusion Protein) Purification .....	30
2.10. Protein Estimation by Bradford Assay .....	31
2.11. EMSA (Electrophoretic Mobility Shift Assay) .....	32

### III. RESULTS AND DISCUSSION

3.1. Compensatory Mutants of U12 and U6atac snRNAs At Helix I Intermolecular Interaction Region .....	34
3.2. Compensatory Mutants Affect <i>in vivo</i> U12-dependent Splicing Efficiency ...	34
3.3. Compensatory Mutants of U12 and U6atac snRNAs At Helix Ib Intermolecular Interaction Region .....	37
3.4. <i>In vivo</i> Genetic Suppression Assay Using P120 Minigene Intron F Can Detect Predicted Base Pairing of U12-U6atac and U6atac-U4atac snRNAs .....	37
3.5. Single Nucleotide Mutants of U12, U6atac and U4atac snRNAs At Helix Ia Interaction Region Could Not Prevent Splicing .....	40
3.6. Splicing Efficiency Is Almost Unaltered With Single Nucleotide Mutation In Helix 1b Region of Interaction.....	40
3.7. Analyses of Single Mutations from <i>in vivo</i> spliced phenotypes ... ..	41
3.8. Double Nucleotide Mutations of U4atac, U6atac and U12snRNAs in helix Ia Region Inhibit <i>in vivo</i> U12-dependent Splicing .....	44
3.9. Analyses Of <i>in vivo</i> Splicing Phenotypes From Double Mutations of U12, U6atac and U4atac snRNAs In Helix Interacting Region.....	45
3.10. Different snRNA Elements Might Share Common Minor Spliceosomal Components during U12- dependent Intron Splicing.....	46
3.11. Mutations Generated in U6atac snRNA 3' SL Between Nucleotides 90 to 110 Can Detect Correct 65K-C-RRM Binding Sites .....	50

3.12. Expected Outcomes from The U6atac snRNA (90-110) Nucleotides Mutations on 65K-C-RRM Protein Binding .....	51
3.13. U6atac snRNA Stem and Loop Nucleotides (90-110) Are Important In U12-dependent <i>in vivo</i> Splicing.....	52
3.14. Analyses of <i>in vivo</i> Splicing Using U6atac snRNA Stem and Loop Mutants with P120 Mutant At 5'Splice Site .....	54

#### IV. CONCLUSION AND FUTURE DIRECTIONS

4.1. Conclusions .....	56
4.2. Future Directions .....	57

BIBLIOGRAPHY.....	60
APPENDIX.....	78

## LIST OF FIGURES

1.1.	Levels of gene expression .....	2
1.2.	Spliceosome in pre-mRNA slicing .....	3
1.3.	Biochemistry of pre-mRNA splicing .....	4
1.4.	Major and minor class introns .....	.4
1.5.	Composition of proteins in major spliceosomal snRNPs .....	.8
1.6.	Predicted secondary structures of human spliceosomal snRNAs .....	.12
1.7.	Spliceosome formation and activity .....	.14
1.8.	Catalytic triad .....	.16
1.9.	Predicted secondary structures of U6atac snRNA 3' end domain .....	.17
3.1.	Base-pairing between U2 and U6 snRNAs, U4/U6 snRNAs .....	35
3.2.	U4atac/U6atac snRNAs Base-pairing in schematic representation .....	36
3.3.	Predicted base-pairing of U12, U6atac and U4atac snRNAs at helix Ib ...	38
3.4.	Schematic representation of Human P120 mini-gene .....	40
3.5.	<i>In vivo</i> single nucleotide splice variants of helix Ia region.....	41
3.6.	<i>In vivo</i> single nucleotide splice variants of helix Ia region (Cont.) ...	41
3.7.	<i>In vivo</i> single nucleotide splice variants of helix Ib region .....	42
3.8.	<i>In vivo</i> single nucleotide splice variants of helix Ib region (Cont.) ...	42
3.9.	Predicted base-pairing of U12, U6atac and U4atac Mutant snRNAs...	45
3.10.	<i>In vivo</i> double nucleotide splice variants of helix Ia region .....	.46
3.11.	Proposed secondary structures of U6atac and U12 snRNAs .....	49
3.12.	Schematic representation of 65K-C-RRM protein interactions .....	50
3.13.	Design of U6atac snRNA Stem and Loop Mutants .....	53
3.14.	<i>In vivo</i> spliced phenotypes of U6atac snRNA Stem and Loop mutants .	55

## LIST OF TABLES

1. Table 3.2(C): Base-pairing interactions of U12, U6atac, U4atac snRNA single nucleotide mutants at helix Ia region ..... 36
2. Table 3.3 (B): Base-pairing interactions of U12, U6atac, U4atac snRNA single nucleotide mutants at helix Ib region ..... 38
3. Table 3.9 (B): Base-pairing interactions of U12, U6atac, U4atac snRNA double nucleotide mutants at helix Ia region ..... 45

## LIST OF ABBREVIATIONS

ATP	Adenosine Tri-Phosphate
cDNA	complementary Deoxyribonucleic Acid
CHO	Chinese Hamster Ovary
CTP	Cytidine Tri-Phosphate
DM	Double Mutant
DMEM	Dulbecco's Modified Eagle's Medium
dNTP	deoxy Nucleotide Tri-Phosphate
EDTA	Ethylene Diamine Tetra-acetic Acid
EMSA	Electrophoretic Mobility Shift Assay
FBS	Fetal Bovine Serum
GTP	Guanosine Tri-Phosphate
PAGE	Polyacrylamide Gel Electrophoresis
Pre-mRNA	Precursor messenger Ribonucleic Acid
RRM	RNA Recognition Motif
RT-PCR	Reverse Transcriptase Polymerase Chain Reaction
snRNA	small nuclear RNA
TBE	Tris-Borate-EDTA
UTP	Uridine Tri-Phosphate
WT	Wild Type

## CHAPTER I

### INTRODUCTION

#### 1.1. Mechanism of Gene Expression

The genes can be compared to books in a library. Just like a book may be taken off a shelf and chosen to be read, similarly, a gene can be expressed to produce a functional RNA and protein molecules in the cell. Gene expression initiates at transcription. Here, the gene (DNA) is copied to produce an RNA molecule. This primary transcript or precursor mRNA essentially has the same sequence as the gene. These sequences are called exons and introns. Of the exons and introns, only the exons carry the information essential for protein synthesis. So, the intron sequences need to be removed from the primary transcript by nuclear pre-mRNA splicing. Splicing results a mature transcript of RNA (messenger RNA) that contains only exons (**Figure 1.1**). Subsequent step of gene expression is called translation. Here, the mRNA is translated into a sequence of amino acids, which eventually define a protein. Just as some books in a library are well thumbed and others are not equally consulted, likewise, there are multiple mechanisms to regulate transcription and translation, which result to differential gene expression (Genetics, Third Edition, 1997, Robert F. Weaver and Philip W. Hedrick).

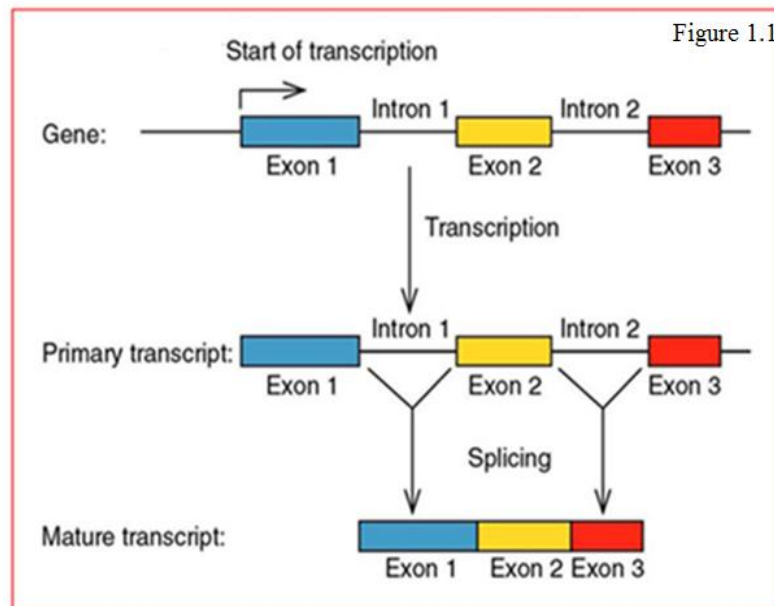

**Figure 1.1: Levels of gene expression:** Gene expression is regulated at steps of transcription and splicing and processing of mRNA towards translation. (Reference: Molecular Biology by Robert Weaver).

## 1.2. Eukaryotic Pre-mRNA Processing

Splicing is the process of modification of RNA in which introns are removed and exons are joined. Typically, precursor transcript of a eukaryotic messenger RNA undergoes through a series of reactions to become a mature mRNA transcript. These reactions are catalyzed by a complex, called spliceosomal complex, constituting of small nuclear ribonucleoproteins (snRNPs) (Genetics, Third Edition, 1997, Robert F. Weaver and Philip W. Hedrick). So, spliceosome is, generally, a huge RNA-protein complex composed of five snRNPs. RNA components of snRNPs interact with the introns (**Figure 1.2**). Within an intron, there is 5' splice site (ss), 3' splice site (ss) and a branch site. 5'ss is called splice donor site. 3'ss is called splice acceptor site.

Two distinct sets of spliceosomes have been identified which contain different snRNPs. Moreover, the type of splicing depends on structure



of the spliced intron and the catalytic components for splicing (Dietrich RC *et al*,1997).

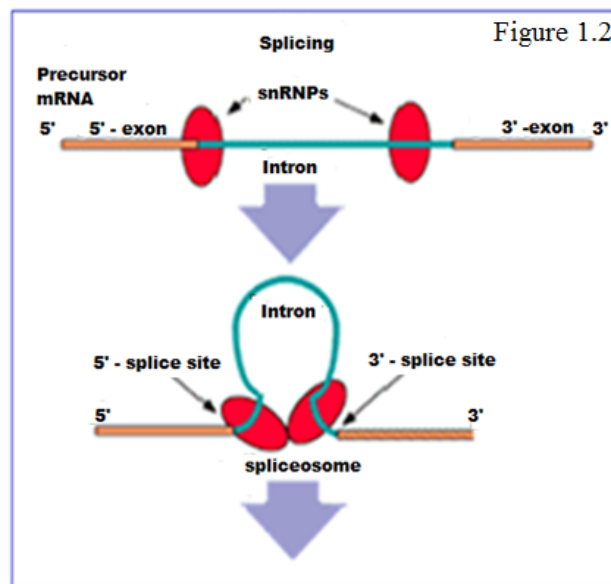

**Figure 1.2: Spliceosome in pre-mRNA splicing:** A nucleo-protein complex is assembled during splicing of a mRNA primary transcript to excise intron. (Reference: Molecular Biology by Robert Weaver).

### 1.3. Biochemical Pathway of Spliceosomal Splicing

Eukaryotic pre-mRNA undergoes two sequential transesterification reactions, catalyzed by snRNPs. First, 2'OH of branch point nucleotide (Adenosine) within the intron performs a nucleophilic attack at first nucleotide of 5'ss of intron. A lariat intermediate is formed. Secondly, 3' OH of the released 5' exon performs a nucleophilic attack at last nucleotide at 3'ss of intron. Flanking exons are joined (**Figure 1.3**).The final products of splicing are: ligated exons (mature transcript) and free intron (lariat debranches), while the snRNPs are recycled (Genetics, Third Edition, 1997, Robert F. Weaver and Philip W. Hedrick).

### 1.4. Introduction of Introns into Eukaryotic Genomes

In higher eukaryotes, there is a large variation in the

length and number of introns. One example is the longest human gene coding for the muscle-specific protein dystrophin, which spans 2.5 million bases, with its exons accounting to < 1% of total length, but, average intron length is 26,000 bases (Pozzoli *et al.* 2002).

Introduction of introns into eukaryotic genomes follows two hypotheses (Darnell 1978, Doolittle 1978, Basu *et al.*, 2007): according to the “intron early” theory, reading frames are discontinuous and so the prokaryotes lost their introns with the increasing compactness of their genomes; whereas, according to “intron late” theory, introns are getting inserted into genes throughout eukaryotic evolution. In addition, the “exon theory” of gene evolution postulated by Gilbert (1987) is based on the idea that, each exon was a separate gene coding for a discrete protein domain and proteins remained functional long before the splicing mechanisms evolved. It was considered that “splicing” event is responsible for formation of longer genes with many exons.

Taken together, the removal of introns from the pre-mRNA is, undoubtedly, a significant event of gene expression.

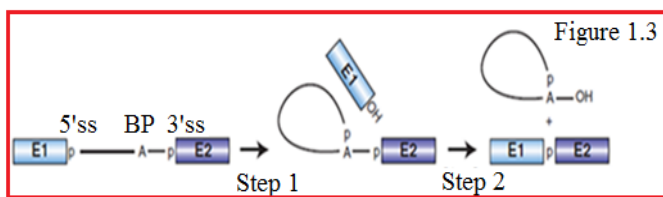

**Figure 1.3: Biochemistry in pre-mRNA splicing:** 3'OH of branch point (BP) of Adenosine (A) in the intron attacks 5' splice site (ss). Lariat is formed. 3'OH of 5' exon triggers a second trans-esterification at 3'ss. Exons are joined. (Reference: Molecular Biology by Robert Weaver).

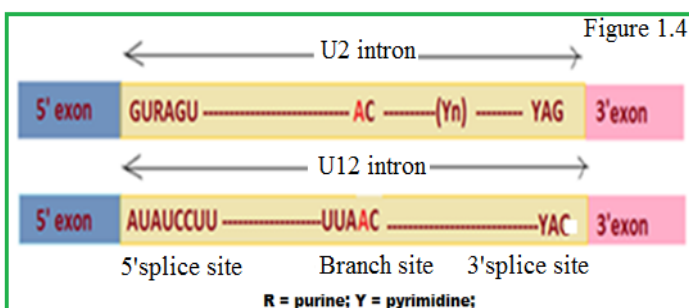

**Figure 1.4: Major and minor class introns and snRNAs involved:** Consensus 5'splice site, branch point sequence and 3' splice site are shown for major and minor class introns. (Reference: Molecular Biology by Robert Weaver).

## 1.5. Spliceosomal Introns

Spliceosomal introns have an almost invariant sequence GT at 5' splice site (SS) end of the intron. An almost invariant sequence AG at 3' splice site (SS) terminates the intron sequence. Upstream from AG, there is usually a region high in pyrimidines (C and T). It is called Poly-Pyrimidine Tract (**Figure 1.4**). Upstream of Poly-Pyrimidine tract is the branch point (BP), which usually includes an adenosine (A) nucleotide (Sheth *et al*, 2006). Majority of introns with GT-AG as flanking sequences, at 5' SS and 3' SS, respectively, account for canonical type of intron splicing. For such introns, U1, U2, U4, U5 and U6 snRNPs constitute the major spliceosomal complex. Their spliceosomal machinery is called major spliceosome. Their splicing process is termed as U2-dependent or major spliceosomal pathway. With short stretches of highly conserved sequences, they account for more than 99% of splicing.

Between years 1989 and 1997, introns with non-canonical flanking splice sites, as for example, in the proliferating cell nucleolar protein P120 gene in Human, were reported. This subset of introns has long and nearly invariant consensus sequences (Jackson, 1991). The first minor class introns found had AT-AC as terminal di-nucleotides instead of the canonical GT-AG, and these introns represent < than 1% of all introns in human. This splicing system uses a different set of snRNAs and it was confirmed by mutational and biochemical analyses (Hall and Padgett, 1996, Tarn and Steitz, 1996a and 1996b, Burge CB, Padgett RA and Sharp PA, 1998). Later, U12-type introns with non-canonical terminal dinucleotide (CT-AC, GG-AG and GA-AG) were also reported (Dietrich RC *et al*, 1997). Nowadays, their spliceosomal machinery is called minor spliceosome, constituting U11, U12, U4atac, U5 and U6atac snRNPs. Their splicing process is termed as U12-type or U12-

dependent or minor spliceosomal pathway. U12-type introns are found in most multicellular organisms. Higher proportion of U12-type introns occur in more complex eukaryotes, as revealed from computational analyses on intron frequencies (Levine and Durbin, 2001, Schneider *et al*, 2004, Alioto 2007). However, simple eukaryotes like nematode (*Trichinella spiralis*), protists (*Physarum polycephalum*) and fungi (*Phytophthora sp.*) also have U12-type introns, but, another nematode (*Caenorhabditis elegans*) is the most notable exception where components of U12-pathways are absent.

The terminal di-nucleotides, however, do not distinguish between the major or U2-type and minor or U12-type spliceosomal introns. As mentioned earlier, many U12-type introns have GT-AG as flanking di-nucleotides. Similarly, many introns with AT-AC as flanking di-nucleotides are spliced by U2-type spliceosome (Wu and Krainer, 1999). However, the persistent conservation of U12-type intron locations between human and plant over such a broad evolutionary distance indicates that U12-type introns have important role in gene expression (Zhu and Brendel, 2003). But, U12-type introns are less efficiently spliced than U2-type introns since pre-mRNA with unspliced U12-type introns are found to be abundant in cells (Patel *et al*, 2002).

## **1.6. Splicing Fidelity**

Splicing mechanics depends on the accurate recognition of introns. In complex eukaryotes, splice sites are often degenerate to demarcate discreet intron boundaries without other signals. So, alternative splicing is common.

For example, over 90 percent of human genes are alternatively spliced (Wang *et al*, 2008). Long consensus sequences of U12-type 5'ss and BP is sufficient for recognition of splice sites, but due to low abundance of U12-type introns, even long sequences are not adequate to locate the introns.

Although splicing patterns are rarely alternative splicing for U12-type introns because of their long consensus sequence and the co-operative intron recognition by U11/U12 di-snRNP, one example of alternative splicing event is on the mRNAs of U11/U12 48K protein. Also, there are instances, where an intron can be spliced by U2-type spliceosome or U12-type at slightly differing splice sites.

Moreover, the *prospero* gene of *Drosophila* (fruit fly) contains a “twintron” consisting of a U2-type intron within a U12-type intron. The splicing of twintron is regulated by a purine-rich element which maneuvers the function of both types of spliceosomes (Hall and Padgett, 1994, Borah *et al*, 2009).

Another means of shuffling of exons among different mRNA molecules, is first identified in *Trypanosoma*, where the regulated splicing is termed as trans-splicing (Bonen, 1993).

## **1.7. Major Spliceosomal Components and Their Biogenesis**

MS (mass spectrometry) sequence of spliceosomal complexes shows that the spliceosome is a multi-megadalton ribonucleoprotein complex and can be defined as the largest intracellular machine (Deckert *et al*, 2006, Jurica and Moore, 2003).

Five snRNAs namely, U1, U2, U4, U5 and U6 are the core components of U2-type or major spliceosomes (Krainer and Maniatis 1985). U1,

U2, U4 and U5 snRNAs , each has U-(uridine) rich conserved sequence, the Sm region, which binds to seven common proteins, namely, B/B', D1, D2, D3, E,F and G (Bringmann and Luhrmann, 1986). U6 snRNP lacks Sm proteins but it has Sm-like proteins, namely Lsm 2-8 (Seraphin, 1995, Salgado-Garrido *et al*, 1999). snRNP – specific proteins like the p110/SART3 of U6snRNP restore the U4-U6 snRNAs base-pairing (Bell *et al*, 2002). DExD/H box proteins like U5-100K, with ATPase and RNA helicase activity are required for conformational changes during spliceosome formation (Staley and Guthrie, 1999). Many non-snRNP proteins mediate RNA-RNA interactions, as for example, U2AF-65 anneals U2 snRNA with branch point sequence (Valcarcel *et al*, 1996). Moreover, auxiliary proteins are also required to bind to exonic and intronic splicing enhancers in addition to the spliceosomal core proteins. The composition of proteins in major spliceosomal snRNPs are pictorially represented (**Figure 1.5**).

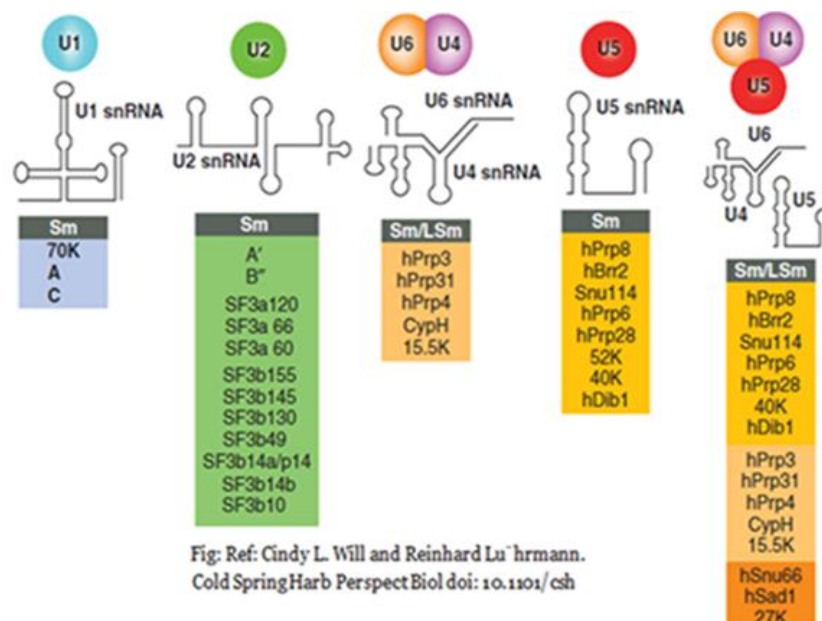

**Figure 1.5: Composition of proteins in major spliceosomal snRNPs (Human):** “Sm” denotes Sm proteins (B/B', D3, D2, D1, E, F and G. “Lsm” proteins are (Lsm 2-8) associated with each snRNP. U4/U6.U5 tri-snRNP contains two sets of Sm proteins and one set of Lsm proteins.

In multicellular organisms, spliceosomal snRNPs transiently localize in cytoplasm during their biogenesis (Will and Lührmann 2001, Patel and Bellini 2008). After transcription by RNA polymerase II, each of U1, U2, U4 and U5 gets a mono-methylated cap and are exported from the nucleus (Ohno *et al.* 2000). In cytoplasm, seven Sm proteins assemble on Sm site, which is assisted by SMN complex consisting of seven Gemin proteins (2-8) (Pellizzoni *et al.* 2002). Next, the cap modifies to 2, 2, 7-tri-methyl-guanosine (m3G) structure (Mattaj 1986). Both the cap and Sm complex contain nuclear localization signals (NLS) that re-import snRNPs back to nucleus, being mediated by the import adapter snurportin1 (Fischer and Lührmann, 1990, Huber *et al.* 1998, Narayanan *et al.* 2004). Now, snRNPs acquire their specific proteins and are internally modified by pseudo-uridylation and 2'-O-methylation (Yu *et al.* 2001). Newly assembled snRNPs accumulate in sub-nuclear organelles termed Cajal bodies (Sleeman and Lamond 1999, Jády *et al.* 2003). Cajal bodies may also be the sites for recycling of the U4/U6.U5 tri-snRNP (Stanek *et al.* 2003, Schaffert *et al.* 2004). Mature snRNPs are enriched in interchromatin granule, which are presumed as storage sites for splicing factors (Matera and Ward, 1993, Lamond and Spector 2003).

U6 snRNA is transcribed by the RNA polymerase III (Kunkel *et al.* 1986) and is believed not to be exported out of the nucleus. The poly-uridine tail of nascent U6 is transiently bound by the La protein (Rinke and Steitz 1985, Pannone *et al.*, 1998). The triphosphate cap is modified into a gamma-monomethyl phosphate cap (Shimba and Reddy 1994). As the other spliceosomal snRNAs, U6 is also modified by pseudo-uridylation and 2'-O-methylation by small nucleolar RNPs, probably in the nucleolus (Tycowski *et al.*, 1998). U4 and U6 snRNPs interact by base

pairing to form the U4/U6 complex and associate with U5 by protein interactions, forming the tri-snRNP U4/U6.U5 (Bringmann *et al.* 1984, Hashimoto and Steitz 1984, Cheng and Abelson 1987, Konarska and Sharp 1987).

### **1.8. Minor Spliceosomal Components and Their Biogenesis**

U1, U2, U4 and U6 snRNAs of U2-type or major spliceosome are functional analogues for U11, U12, U4atac and U6atac snRNAs of U12-type or minor spliceosome, respectively, whereas U5 is shared between both splicing machinery (Montzka and Steitz 1988, Hall and Padgett 1994, Tarn *et al.* 1995, Hall and Padgett 1996) (**Figure 1.6**).

Proteomic analysis of purified spliceosomal complexes indicate that, over 170 proteins are found associated with the major spliceosome, although many proteins are also shared by the minor spliceosome. Unlike U1 and U2, which exist mainly as mono-particles, U11 and U12 form a di-snRNP through protein-protein interactions (Wassarman and Steitz 1992b) and lack U1-specific proteins but contain most proteins present in U2 snRNP, such as the SF3b complex. U11, U12 and U4atac snRNPs contain Sm protein complex.

In addition, U11/U12 snRNP contains seven unique, novel proteins not found in the U2-dependent spliceosome, designated 65K, 59K, 48K, 35K, 31K, 25K, and 20K, all of which are essential for cell viability (Will *et al.* 1999, Will *et al.* 2004). 59K, 48K, 35K and 25K are detected also in U11 mono-particles. 65K binds U12 snRNA and 59K binds U11 snRNA, thus bridging U11 and U12 snRNPs (Benecke *et al.* 2005). 35K recognizes 5' splice site just like its homolog, U1-



70K (Will *et al.* 1999). 48K protein binds 5' ss to transiently interact with U11-associated 59K and has a role in U11/U12 di-snRNP stability (Turunen *et al.* 2008, Tidow *et al.* 2009).

U11/U12-65K, -35K and -31k proteins, which are found to contain RNA Recognition Motifs (RRMs), are the essential snRNA binding proteins, which are presumably involved in di-snRNP formation and intron bridging.

The minor spliceosome tri-snRNP U4atac/U6atac.U5 forms similarly (Tarn and Steitz 1996a, Tarn and Steitz 1996b) like major tri-snRNPs. Protein components of the U6atac/U4atac.U5 tri-snRNP, also, do not differ from those in the major tri-snRNP (Luo *et al.*, 1999, Nottrott *et al.*, 2002, Schneider *et al.*, 2002). Just like U6snRNA, U6atac snRNA lacks Sm binding site and instead, it is assembled with Sm-like proteins, the Lsm 2-8 complex, which replaces the La protein and serves as NLS (Achsel *et al.* 1999, Schneider *et al.*, 2002, Spiller *et al.*, 2007).

In sum, it is important to note that, proteins involved in the splicing play critical role in recognizing and pairing of splice site and ensure the dynamicity as well as conservation of the splicing event.

## **1.9. Catalytic Reactions during Splicing**

RNA catalyzes splicing reactions and the spliceosome becomes a ribozyme (Kruger *et al.* 1982, Cech 1986; Valadkhan 2007). For example, U2 and U6 snRNAs catalyze a splicing-like reaction free of proteins *in vitro* (Valadkhan and Manley 2001, Valadkhan *et al.* 2009). RNA molecules in catalytic core of the spliceosome form structures which look identical to the conformation of self-splicing Group II introns. So, spliceosomal introns have presumably evolved from

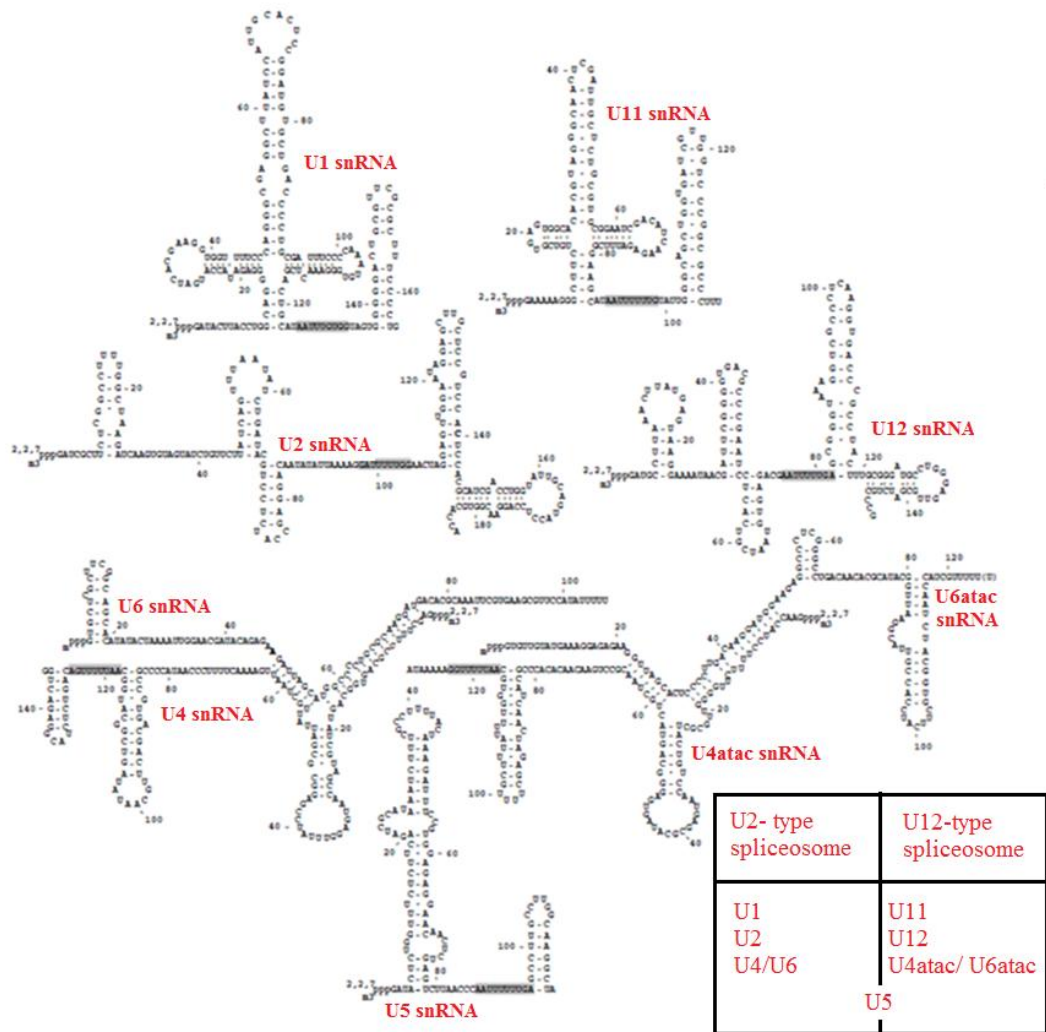

**Figure 1.6: Predicted secondary structure of human spliceosomal snRNAs:** U1, U2, U4, U5 and U6 snRNAs (Yu et al, 1999), U11 and U12 snRNAs ( Tarn and Steitz, 1997), U4atac and U6atac snRNAs (Padgett and Shukla, 2001); grey shades are Sm complex binding sites. Table shows functionally analogous U2-type and U12-type snRNAs.

self-splicing introns (Sharp 1985, Toor *et al.* 2008).

The spliceosome might have originated through dispersion of the self-splicing intron ribozyme core into many small RNAs (Jarrell *et al.* 1988, Sharp 1991). The fact that, catalytic domain of self-splicing group II intron functionally replaces the metal binding stem loop in U6atac snRNA supports this presumption (Shukla and Padgett 2002).

## 1.10. U2-type / Major Spliceosomal Assembly and Dis-assembly

RNA components of snRNPs interact with the intron along with many other proteins which are required for the spliceosomal assembly. After final products of splicing are formed, snRNPs are recycled for next round of splicing. In U2-type, these are the following sequential events (**Figure 1.7**):

In E complex, splice site consensus sequence is first recognized by U1snRNP and U1 snRNP binds to GT at 5' splice site (ss). SF1 (splicing factor 1) binds to branch point sequence. Accessory proteins, U2AF subunits 65K and 35K, bind to Poly-pyrimidine tract and 3'SS, respectively (Mount *et al.*, 1983, Black *et al.*, 1985, Zamore and Green, 1989, Abovich and Rosbash, 1997, Staley and Guthrie, 1998, Smith *et al.*, 2008). The base pairing interactions of U1 with 5'ss spans -1 to +6 nts. with respect to 5'ss.

In A complex (pre-spliceosome complex), U2snRNP displaces SF1 and binds to branch site with ATP hydrolysis and bulges out the branch point adenosine (Parker *et al.* 1987, Query *et al.* 1994).

In B1 complex, U4/U5/U6 tri-snRNP binds. U5 binds exons at 5'SS. U6 binds to U2.

In B2 complex, U1 is released. U5 shifts from exon to intron. U6 binds at 5'SS (Konarska and Sharp 1987, Sawa and Abelson 1992, Wassarman and Steitz 1992a). Helicase activity of ATP-hydrolyzing proteins promotes the re-arrangement of the complex (Staley and Guthrie 1998). U6 forms two helices with U2, bringing the 5' ss and BP into close proximity (Hausner *et al.* 1990, Madhani and Guthrie 1992). U5 contacts 5' ss on exon side and 3' ss for the first step

of splicing (Newman and Norman 1992, Sontheimer and Steitz 1993). The protein composition of the activated spliceosome is also re-modeled now (Makarov *et al.* 2002).

In C1 complex, U4 is released. U6/U2 catalyzes transesterification. 5' end of intron ligates to A on intron. Lariat forms. In C2 complex, U2/U5/U6 remains bound to lariat. 3' ss is cleaved. Exons are spliced with ATP hydrolysis. Final products are spliced RNA and de-branched intron lariat. Some reports suggest that the spliceosome may exist as a preassembled complex. For example, all five spliceosomal snRNPs have been detected in yeast and HeLa cell nuclear extracts (Stevens *et al.* 2002, Malca *et al.* 2003). However, a preformed penta-snRNP is not a prerequisite for splicing *in vitro* (Behzadnia *et al.* 2006).

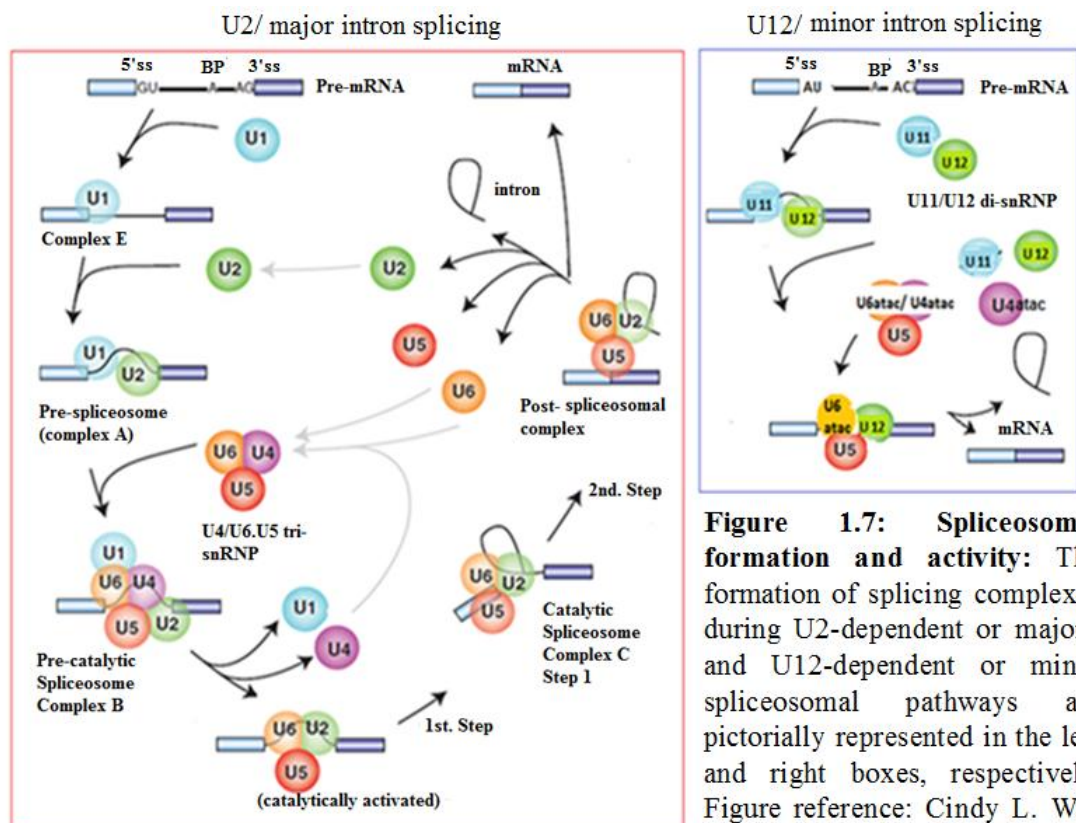

**Figure 1.7: Spliceosomal formation and activity:** The formation of splicing complexes during U2-dependent or major-, and U12-dependent or minor spliceosomal pathways are pictorially represented in the left and right boxes, respectively. Figure reference: Cindy L. Will and Reinhard Luhrmann. Cold Spring Harb Prespect Biol.

### **1.11. U12-type / Minor Spliceosomal Assembly and Dis-assembly**

U12-type spliceosomal assembly is almost similar to U2-type cascade of interactions (**Figure 1.7**). Unlike U1 and U2 in major spliceosome, U11 and U12 snRNAs form a di-snRNP and recognize the 5'ss and BP co-operatively (Frilander and Steitz, 1999). The first three nucleotides of 5' ss are recognized by U11-48K protein (Turunen *et al*, 2008). So, U11 base pairs from +4 to +8 nts. at 5'ss. The U4atac/U5/U6atac tri-snRNP enters to form the B complex. U11 and U4atac snRNAs are displaced. U6atac and U12 snRNAs base-pairs at 5'ss (Yu and Steitz, 1997, Frilander and Steitz, 2001).

Important molecular structures and interactions remain conserved during spliceosomal assembly (Kolossova and Padgett, 1997, Yu and Steitz, 1997, Incorvaia and Padgett, 1998). It has also been proved that, splicing activity is restored when the conserved intra-molecular stem loop of U6atac snRNA is replaced by a chimeric form of U6 snRNA (Shukla and Padgett, 2001).

Moreover, U4atac snRNA could also be replaced by U4 snRNA, if appropriate base-pairing could be restored with U6atac snRNA (Shukla and Padgett, 2004).

### **1.12. Dynamic RNA-RNA Interactions in Helices of Spliceosomal snRNAs**

Iterative conformational changes in snRNAs at different stages of splicing are adapted for effective RNA-RNA interactions. RNAs of Group II introns are found to fold intricately for self-splicing and undergo same stereochemical reactions as the spliceosomal snRNAs with its pre-mRNA substrate.

U2 and U6 snRNAs form three helices, namely Ia, Ib and

II (Madhani and Guthrie, 1992). Helix I is presumed to get disrupted after first step of splicing but re-forms in the next step (Mefford and Staley, 1995; Sashital *et al*, 2004). Likewise, U2 snRNA forms Stem IIc to promote first catalytic step of splicing and then toggles to another mutually exclusive Stem IIa conformation required for exon ligation (second step of splicing) (Hilliker *et al*, 2007; Perriman and Ares 2007). In U12-type splicing, U6atac snRNA base pairs with U12 snRNA to interact at helix Ia and helix Ib whose sequences are almost identical in the two splicing systems (Shukla and Padgett 2004).

### 1.13. Homologous RNA Elements in Catalytic Triad

Both spliceosomal and self-splicing group II introns require the function of a highly conserved, metal-ion ( $Mg^{2+}$ ) -binding catalytic triad (AGC) present in RNA stem-loop elements located in U6 or U6atac snRNAs and also in Domain 5 (D5 Stem 1) of Group II introns (**Figure 1.8**) (Madhani and Guthrie, 1992; Chanfreau and Jacquier, 1994; Peebles *et al*,1995; Abramovitz *et al*,1996; Konforti *et al*,1998; Yu *et al*,1995; Yean *et al*, 2000; Gordon and Piccirilli,2001; Villa *et al*,2002; Shukla and Padgett,2002; Griffiths-Jones *et al*,2005; Davila Lopez *et al*,2008; Butcher and Brow, 2005).

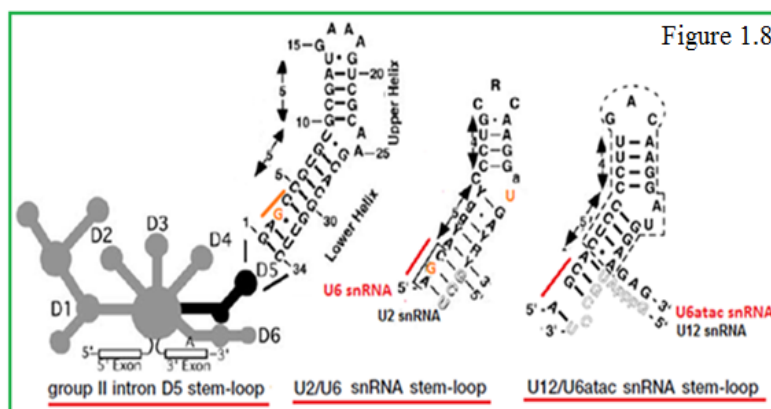
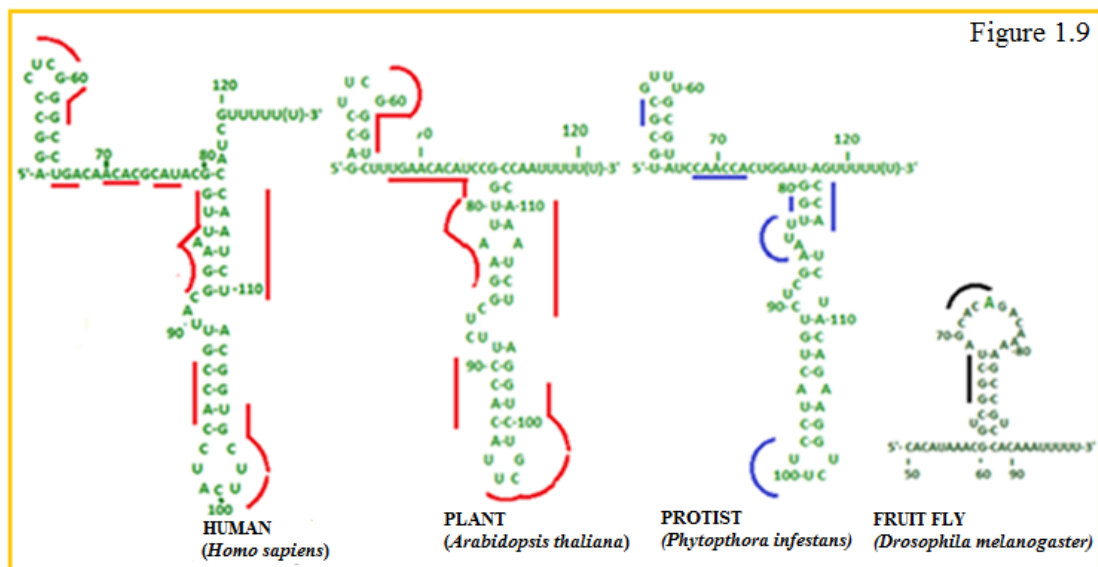

Figure 1.8

**Figure 1.8: Catalytic triad:** RNA elements in the catalytic triad of Group II intron D5 SL, U2/U6 snRNA SL and U12/U6atac snRNA SL. Figure reference: Shukla and Padgett, 2002.

### 1.14. Conserved RNA Elements among Divergent Eukaryotic Lineages

Sequence analyses of a large number of genome for spliceosomal snRNAs have identified snRNA homologies within distant lineages (Lopez *et al*, 2008). For example, 3' end domain of U6atac snRNA shows substantial conservation across different species. Within the 3' end domain, the 5' stem-loop and the 3' stem-loop structures are well conserved among divergent eukaryotic lineages (**Figure 1.9**). 3' end domain of human U6atac snRNA shows ~65% identity with that in plant. However, the good homology existing between human (*Homo sapiens*), protist (*Phytophthora infestans*) and plant (*Arabidopsis thaliana*) in their 5' stem-loop and 3' stem-loop structures of U6atac snRNA 3' end domain predicts the functional significance for such phylogenetic conservation among divergent lineage.



**Figure 1.9: Predicted secondary structures of U6atac snRNA 3' end domain among divergent eukaryotic lineages:** Conserved elements are marked in red, blue and black lines. Figure reference: Shukla Grant and Lopez *et al*, 2008.

### 1.15. Evolutionary History of the Two Spliceosomes

Major (U2)-type introns are small ubiquitous in

eukaryotes but U12-type introns are not. Minor spliceosomes remove a small fraction (less than 0.5%) of introns, referred to as U12-type introns (Lin CF *et al*, 2010). But, analogous structures and similar enzyme kinetics of major (U2) - and minor (U12) - spliceosomes in the same living organism, suggest their common ancestry. To understand the evolution of the splicing machinery and of the spliceosomal RNAs, phylogenetic distribution of both have been systematically examined.

Earlier studies have proposed (Burge *et al*, 1998) that a “subtype switch” from AT-AC to GT-AG could serve as an intermediate stage for conversion from U12-type introns to U2-type introns. As an evidential proof, one of the nineteen U12-type introns was detected in fruit fly (*Drosophila melanogaster*) to be the first known example for U12-type to U2-type intron conversion. But, the loss of U12-type introns was found to be more frequent than such conversion. Moreover, natural U12-type introns with non-canonical terminal dinucleotide (CT-AC, GG-AG and GA-AG) were also reported (Dietrich RC *et al*, 1997). Investigation revealed an early origin of U12-type spliceosomal RNAs being present in a variety of evolutionarily distinct phyla. U12-type introns were found to be highly conserved among vertebrates.

Other notable information was that, there has been a significant loss of U12-type of introns in invertebrate lineages, compared to vertebrate lineages. From the fact that U12-type introns and snRNAs exist in both plants and animals, it was proposed (Burge *et al*, 1998) that, the U2- and U12-types splicing pathways diverged from one in the course of speciation (fission) and later merged (fusion) on one organism. By fission-fusion hypothesis, it was reasoned that, the similar secondary structure and interaction between U2- and U12-types of spliceosomal snRNAs are not due to convergent evolution.



In contrast, the endosymbiotic theory mentions of a unicellular eukaryotic ancestor, carrying introns and a spliceosome, diverged to two lineages which gained cumulative differences in spliceosomal components and intron consensus sequences. With time, these two split lineages fused by endosymbiosis and gave rise to the ancestor of present day eukaryotes.

The homologous proteins in U2- and U12-types of spliceosomes could be a result of duplication and specialization of genes for proteins that were primarily shared (Lynch and Richardson, 2002). It was argued that the two splicing systems originated from two Group II type self-splicing introns, and the spliceosomal proteins were similar between the functionally analogous snRNAs (Russell AG *et al*, 2006). Supporting to this hypothesis, it was suggested (Basu *et al*, 2008) that U12-type introns first populated ancestral genome to a certain intron density and their successive invasions got restricted due to limited space available for further insertion of new genes. Moreover, analyses of proto-splice sites in human and plant (*Arabidopsis thaliana*) genomes confirmed that, U2-type introns predate U12-type introns.

It is noteworthy that, there are multiple instances in species or branches, where not only U12 spliceosomal components are missing, the U12-type introns are lacking, as well. A few examples are the *Entamoeba histolytica*, green algae and fungal lineage, *Basidiomycota*. In addition, there are instances, where U12-type RNAs were present in very early fungal evolution while they are lacking in Microsporidia (Fungi). Again, U12-type splicing does not occur in *Caenorhabditis elegans* (nematode), whereas, both U12 introns and U12 snRNAs are present in *Trichinella spiralis*, which is a deep branching of the nematode tree.

U12 introns have been identified from BLAST searches. In addition, EST sequences have been retrieved using NCBI Entrez to obtain a database of genomic sequences. Investigations reveal that phylogenetic distribution of U12 introns and spliceosomal RNAs support to an early origin of U12 dependent splicing (Davila Lopez M *et al*, 2008). It is not yet known if the loss of minor spliceosome could result as a consequence of the strong pressure to reduce genome size. But, it has been identified in many similar instances, as discussed above, where U12-dependent splicing was lost somewhere during the course of eukaryotic evolution. Hence, it is concluded that U12-type splicing has a comparatively marginal role and, therefore, getting disposed of in many phylogenetic groups. Moreover, the phylogenetic distribution of U12 introns is directly correlated to the U12 snRNA distribution (Bartchat *et al*, 2010). But the origins of the two parallel splicing systems remain elusive till date.

### **1.16. Significance of Study of Minor Spliceosomes**

Study of splicing is important in its relevance to diseases. Mutations lead to aberrant splicing. For example, cis-acting mutations in cystic fibrosis trans-membrane conductance regulator gene cause exon skipping (Pagani *et al*, 2005). Abnormal *tau* exon 10 splicing causes Alzheimer's disease (Liu and Gong, 2008). Splicing abnormalities are common in cancer, as for example, oncogenic isoforms of ribosomal protein S6 kinase  $\beta$ 1 increase (Qi Ma *et al*, 2011).

Abnormal U4atac/U5/U6atac snRNP complex causes retinitis pigmentosa, which characterizes retinal degeneration leading to blindness (Makarova *et al*, 2002).

Spinal muscular atrophy (SMA) causes childhood lethality, due to mutations in the genes encoding motor neuron protein, SMN. SMN deficit causes reduction in spliceosomal snRNP levels, particularly U11 snRNA (Livio Pellizzoni, 2007).

Four point mutations in U4atac snRNA of minor spliceosome are found in patients with MOPD 1 (Microcephalic Osteodysplastic Primordial Dwarfism type 1) (Huiling He *et al*, 2011).

The list is inexhaustible but fact remains, that the splicing of minor introns plays critical roles in human development.

## CHAPTER II

### MATERIALS AND METHODS

#### 2.1. Mutant Construction

The single nucleotide and adjacent two or three nucleotide mutations in U12, U11, U6atac and U4atac snRNAs were generated from expression plasmid background by site directed mutagenesis with Change-IT mutagenesis kit (USB Corporation). Using 10X buffer, 5  $\mu$ M of 5'phosphorylated mutagenic oligonucleotides (primer), dNTPs and 15 ng of plasmid, the PCR product was subsequently treated to Dpn I, to degrade the template plasmid. The plasmid was transformed into *E. coli* DH5 $\alpha$  competent cells and plated on Ampicillin (100mg/ml) contained in agar plates. Each colony was picked from plate and grown overnight in an autoclaved glass tube with 5ml Luria-Bertani broth (Amresco, OH) and 5  $\mu$ l of Ampicillin (100mg/ml), in 37 °C at 250 rpm incubator shaker. Zippy miniprep kit (Zymo Research) was used to make plasmid mini-preps from overnight cultures. Once the sequences of mutant snRNAs were confirmed by DNA sequencing, maxi-preps were done using Qiagen Plasmid Maxi Kit. Construction of single nucleotide mutants and adjacent two and three nucleotides mutants are listed below.

### **Mutants For Helix Ia Region of Interaction:**

The single nucleotide mutations on U12 snRNA were A9U, A10U, C11G, U12G and U13A. The single nucleotide mutations on U6atac snRNA were A21U, G22U, G23C, U24A and U25A. The single nucleotide mutations on U4atac snRNA were A63U, A64U and C65G. All mutants were named after the nucleotide position where mutations were done.

The adjacently two nucleotide mutations on U12 snRNA were AA9/10UU, AC10/11UU, CU11/12GG, and UU12/13GA. The adjacently two nucleotide mutations on U6atac snRNA were AG21/22UU, GG22/23UC, GU23/24CA and UU24/25AA. The adjacently two nucleotide mutations on U4atac snRNA were AA63/64UU, and AC64/65UG. All mutants were named after the nucleotide position where mutations were done.

### **Mutants For Helix Ib Region of Interaction:**

The single nucleotide mutations on U12 snRNA were C5G, C5U and C5A, and, U6C, U6G and U6A. The single nucleotide mutations on U6atac snRNA were A26G, A26C and A26U, and, G27A, G27C and G27U. The single nucleotide mutations on U4atac snRNA were C61U, C61G and C61A, and, U62C, U62G and U62A. All mutants were named after the nucleotide position where mutations were done.

### **Mutants For U6atac snRNA 3' SL Region:**

Mutations for U6atac snRNA stem and loop nucleotides at 3'SL region were generated following the same principle and procedure, using Change-IT site directed mutagenesis kit. (USB Corporation). U11 snRNA mutants, also generated likewise, are listed in Appendix.

## 2.2. *In vivo* Genetic Suppression Assay

One snRNA expression plasmid, which contains mutations in a region, can restore the complementarity to its interaction with a second snRNA expression plasmid, provided that, this second snRNA expression plasmid contains complementary nucleotide mutations in its region of interaction with the first mentioned snRNA expression plasmid. The mutations in two interacting snRNA expression plasmids can reactivate correct splicing, after co-transfection of both expression plasmids, which express the snRNAs carrying compensatory mutations in their region of interaction.

The same principle behind *in vivo* genetic suppression assay was applied to P120 mini-gene plasmid, which contains exons 5, 6, 7 and 8 and introns E, F and G of the human nucleolar protein P120 gene. The 5'ss (splice site) of U12-dependent intron F, if contains CC5/6GG mutation, abolished U12-dependent splicing of intron F, *in vivo*. On co-transfection with U11 snRNA GG6/7CC suppressor mutant and U6atac snRNA GG14/15CC suppressor mutant, the U12-dependent splicing to the P120 CC5/6GG splice site mutant was restored. So, the restoration of correct U12-dependent splicing to the 5'ss mutant, by compensatory mutants of U6atac snRNA and U11 snRNA, allowed us to test the effect of other alterations in U12, U11, U6atac and U4atac snRNAs on their function, *in vivo*. P120 mini-gene construct, P120 CC5/6GG (mutation only at 5'ss), P120DM mutant (double mutations, at both 5'ss and branch site), U11 snRNA expression plasmid, U6atac snRNA expression plasmid, U4atac snRNA expression plasmid were the starting materials for this assay.

P120 mini-gene construct (P120 WT, wild type) and the U11 snRNA GG6/7CC suppressor mutant and U6atac snRNA GG14/15CC suppressor mutant, cloned in pALTER expression vector, were the combined gift from Dr. Richard

A. Padgett, Lerner Research Institute, Cleveland Clinic Foundation in Cleveland, Ohio.

### **2.3. CHO Cell Maintenance and Transfection**

CHO (Chinese Hamster Ovary) cell line was obtained from American Type Culture Collection (Manassas, VA). Cells were cultured in 100 mm plate with 10 ml complete CHO media, containing DMEM (Dulbecco's Modified Eagle's Medium, 1X) supplemented with 4.5 g/l glucose and L-glutamine (CCF, OH), antibiotics (100units/ml penicillin G sodium and 100µg/ml streptomycin sulfate), 5% Fetal Bovine Serum (FBS, Atlanta Biologicals, Inc., Lawrenceville, GA), 1 mM L-proline (Sigma, MO) and 10 mM HEPES (SIGMA, MO). All cells were kept in a humidified incubator at an atmosphere of 5% CO<sub>2</sub> at 37 °C.

For transfection, a 100% confluent 100 mm plate was split at 1:8 ratios in 100 mm plates, using 10 ml complete CHO media. Cells were ~70 % confluent after 24 hours. Morphologically healthy cells were transfected using 5 ml complete CHO media containing 12 µl polybrene (10 mg/ml Sigma, MO) and 1 µg plasmid DNA per plate. 9 µg pUC19 was used as carrier in order to equalize amount of DNA being added. In wells where both U11 suppressor plasmid, U6atac suppressor plasmid and U4atac suppressor plasmid were transfected together, pUC19 vector was omitted. For the followed 8 hours, the transfected plates were maintained in 37 °C in a humidified 5 % CO<sub>2</sub> incubator, with gentle swirling every one hour. After 8 hours, media from wells were aspirated and cells were treated with 5 ml of 30 % DMSO (Dimethyl sulfoxide, prepared in CHO media) and incubated at room temperature for 5 minutes. Plates were washed with 5 ml of CHO media. Final step was replenishing each plate with 10ml of CHO media and putting the plates back to 37 °C in a humidified 5 % CO<sub>2</sub> incubator. The cells were harvested after 36 hours of incubation from post-DMSO

shock time-point.

#### **2.4. Total RNA Isolation**

Isolation of total RNA from cultured CHO cells was done using High Pure RNA Isolation kit (Roche). Cells were suspended in 200  $\mu$ l PBS in 15 ml tubes. 400  $\mu$ l of Lysis buffer (pH= 6.6) containing Tris-HCl was added to each tube and contents are vortexed. Contents from each 15 ml tube were transferred to separate polypropylene High Pure Filter tube fitted to a collection tube. Each tube assembly was then centrifuged for a short spin at 8000 x g for 60 seconds. Flow through was discarded and the collection tube was fitted back to each respective filter tube. 90  $\mu$ l of DNase incubation buffer containing NaCl, Tris-HCl and  $MnCl_2$  was mixed with 10  $\mu$ l of 10 KU DNase I (suspended in Elution Buffer) for removal of contaminant DNA. The contents were incubated for 20 minutes at temperature between 15°C and 25 °C. 500  $\mu$ l Wash Buffer containing ethanol was then added to each tube assembly followed by a centrifugation for a short spin at 8000 x g for 60 seconds. Flow through was discarded and the collection tube was fitted back to each respective filter tube. The wash buffer step was repeated followed by centrifugation at 13000 x g for 2 minutes to ensure complete removal of residual impurities and residual wash buffer. Flow through was again discarded and, for each time, the collection tube was fitted back to respective filter tube. After a final wash, collection tubes were finally discarded and the filter tubes were fitted to 1.5 ml tubes before the elution step. 100  $\mu$ l of Elution Buffer was added and each tube was centrifuged at 8000x g for 60 seconds. The micro-centrifuge tubes containing the eluted RNAs were immediately transferred to -80 °C until further use. Each isolated RNA was quantified under spectrophotometer and absorbance was recorded at 260/280 nm.



Furthermore, the integrity of RNA was checked on a denaturing 1% MOPS-Agarose gel.

## **2.5. Reverse Transcriptase- Polymerase Chain Reaction (RT-PCR)**

Gene Amp ThermoStable rTth Reverse Transcriptase RNA PCR kit (Applied Biosystems, CA) was used to perform reverse transcription step to a total RNA of 0.4 µg per reaction. Recombinant *Thermus thermophilus* (rTth) DNA polymerase was used to reverse transcribe RNA to cDNA in presence of Mn<sup>+2</sup> ions and also for PCR amplification for cDNA synthesis from RNA templates. A master mix of 10 µl reaction volume was made using p120 mini-gene specific reverse primer, E-7-8-2 (5'-CTTCTAAGAAGCTCCACCAGCTCAGA-3') at 70 °C for 15 minutes in PTC-100 thermal cycler (BioRad laboratories, CA).

Next step was addition of 40 µl of master mix containing p120 mini-gene specific E-5-6 primer 5'-GGCCCGGGAAGCTGCTGCTGGGGATC-3' to the 10 µl RT product kept on ice. A final reaction volume of 50 µl containing dNTPs and MgCl<sub>2</sub> was ready for PCR with amplification for 39 cycles, consisting of a denaturation step at 95 °C for a minute, annealing and extension step at 55 °C for 1.05 minutes and a final extension step for 7 minutes at 68 °C in a PTC-100 thermal cycler (BioRad laboratories, CA). Positive control pAW109 RNA was provided with control primers DM151 and DM152.

## **2.6. Nested PCR**

Hi Fidelity PCR Kit (Roche, IN) was used to set up a 25 µl total reaction volume for analyzing the in vivo splicing phenotypes.

PCR was done using p120 mini- gene specific primers E6

long 5'- TTGTGCTGCCCCCTGCTGGGGAGATG-3' (forward) and E7 long 5'- TGAGCCCCAAAATCAGCAGAATTCC-3' (reverse). PCR program was set with denaturation at 95 °C for 3 minutes, followed by 29 cycles of denaturation at 95 °C for a minute, annealing step at 60 °C for 1.05 minutes, extension at 68 °C for a minute and a final extension step at 68 °C for 7 minutes. PCR products were analyzed by ethidium-bromide-stained 3 % Agarose (2 % Agarose: 1 % NuSieve agarose) in 1X TBE gel, ready to be observed on Typhoon Scanner.

## **2.7. *In vitro* Transcription**

Maxi script Kit (Ambion, TX) was used to set up *in vitro* transcription of DNA from PCR products. At room temperature, 50 µl reaction volume was made with the following reagents added sequentially to each 1.5 ml micro-centrifuge tube: 12.5 µl of Nuclease free sterile water, 5 µl 10X Transcription Buffer (with DTT, Dithiothreitol), 2.5 µl 10 mM ATP, 2.5 µl 10 mM UTP, 2.5 µl 10 mM GTP, 2.5 µl 10 mM CTP, 10 µl (2 µg) linearized DNA template, 2.5 µl [ $\alpha$ -<sup>32</sup>P] UTP 800 Ci/mmol (10 mCi/mL- MP Biomedicals, OH) and finally 5 µl T7 RNA Polymerase (10 U/µl). All reactions were incubated at 37 °C for 2 hours. 2 µl RNase-free DNase I (2 U/µl) was added to the reaction mixture to remove DNA template, mixed thoroughly, and incubated for 20 minutes at 37 °C. Gel loading Buffer II (Ambion, TX) was added to the contents in each reaction tube. Samples were loaded on the wells of pre-electrophoresed 5% polyacrylamide/ 8M Urea gel prepared from 40% A: B (19:1), TEMED and APS (Ammonium per sulfate). The gel was run behind a  $\beta$ -blocker screen.

As control, pTRI-Actin was also transcribed with T7 polymerase and loaded in one well, and, expected size of its transcripts is 304 bases.

Finally, the gel was covered with a saran wrap carefully and exposed to phosphor imager screen for about 1 minute and scanned. Bands were subsequently excised from the gel. The eluted RNA in 30  $\mu$ l Elution Buffer was kept in 1.5  $\mu$ l micro-centrifuge tubes with caps sealed with parafilm and then placed on a rotator for 3 hours. The supernatants were collected in fresh 1.5  $\mu$ l micro-centrifuge tube, with 900  $\mu$ l ethanol and 40  $\mu$ g glycogen (Roche, IN) in each. Overnight precipitated RNA was taken out from -20  $^{\circ}$ C, centrifuged at 13000 rpm for 20 minutes. Pellets were re-suspended in nuclease-free H<sub>2</sub>O and stored at -20  $^{\circ}$ C in  $\beta$ -blocker, until further use.

## **2.8. GST-FP (GST-Fusion Protein) Expression**

2X YT media was prepared with 16 g Tryptone, 10 g yeast extract, 5 g NaCl in 900 ml distilled water and pH was adjusted to 7.0 with NaOH. Total volume of 1 liter of 2xYT was sterilized by autoclaving for 20 minutes. On cooling, 1 ml of 100 mg/ml Ampicillin stock solution (final concentration 100  $\mu$ g/ml) was added before use. pGEX-6p1 vector containing *E. coli* strain BL-21 was grown overnight in mini cultures of 5 ml of 2xYTA media. On following day, 5 ml overnight culture was transferred to a 250 ml flask with ampicillin added. The culture was kept in incubator shaker at 37  $^{\circ}$ C with 250 rpm until A<sub>600</sub> reached nearly 0.8, indicating exponential growth. 10 ml of the culture was now segregated from the 250 ml culture.

To the 240 ml culture, 5  $\mu$ l of 1M IPTG/50 ml culture was added. Induction of lactose analog, IPTG (Isopropyl  $\beta$ -D Thio-Galactoside) was expected to be observed by GST-FPs (Glutathione S-Transferase Fusion Protein) expression. 240 ml culture (with IPTG in a 250 ml flask) and the 10 ml culture (without any IPTG) were put back to incubator shaker at 37  $^{\circ}$ C with 250 rpm.

At 3 hours of post-IPTG induction, cultures were

separately centrifuged at 2000x g for 5 minutes and pelleted. Laemelli Buffer (SDS reducing buffer) with  $\beta$ -mercaptoethanol was added to the pellets. Resulting solutions were heated in a beaker of boiling water for 5 minutes and immediately chilled for 2 minutes on ice, and, centrifuged at 13000x g for 20 minutes at 4°C. Supernatants were rescued from the viscous pellets and bromophenol blue was added before loading the wells of a SDS-PAGE gel with 6% stacking gel and 13% resolving gel.

A BioRad Precision Plus Protein™ Kaleidoscope Marker was loaded on one well. The proteins were electrophoresed at ~200 Volts for about 45 minutes till the bromophenol blue dye travels to the bottom of the resolving gel. The gel was stained in Coomassie blue dye (R-250) and de-stained to detect the induced expression of fusion protein.

## **2.9. GST-FP (GST-Fusion Protein) Purification**

Using ~ 250 ml bacterial culture (O.D. = 1.5-3.0 at  $A_{600}$ , pelleted the bacterial cells by centrifugation and supernatant was removed. The protein purification was performed by using B-PER GST-Fusion Protein purification Kit (Thermo Fischer Scientific, PA).

Cell pellet was suspended in 10 ml of B-PER reagent by pipetting up and down to make a homogeneous cell suspension. The mixture was shaken at room temperature for 10 minutes. To separate soluble proteins from insoluble ones and cell debris, the mixture was centrifuged at 14,000 rpm with Beckman JA17 rotor for 20 minutes. The protein extracts containing about ~90 % of soluble proteins in the supernatant was transferred to a new tube. A second extraction of the pellet with additional B-PER reagent was done to recover remaining soluble protein. The

immobilized glutathione was swirled to make homogeneous gel slurry. 1 ml of the slurry was pipetted to tube containing protein extract. The contents in tube were shaken for 10 minutes at room temperature to allow binding, followed by centrifugation at 2500x g for 5 minutes. The supernatant was discarded and gel was re-suspended with 0.25 ml of wash buffer. The gel slurry of ~ 0.75 ml was transferred to a column fitted to a collection tube and centrifuged at 2000x g for 2 minutes and the column was transferred to a new collection tube. The non-bound proteins were incubated for 5 minutes with 0.5 ml of wash buffer and washed away by centrifugation at 2000x g for 2 minutes. An elution buffer was prepared from 15 µg reduced glutathione added to 2 ml of wash buffer. The GST-FP was eluted by incubation for 5 minutes with 0.5 ml of the prepared elution buffer and subsequent centrifugation at 2000x g for 2 minutes. The spin column was transferred to a new collection tube.

A total of 4 elute fractions were taken and purified elutes of protein were stored in 4 °C until future use. The purified protein was checked for quality on 13 % SDS-PAGE.

## **2.10. Protein Estimation by Bradford Assay**

The determination of concentration of the solubilized protein was done by addition of Bradford Solution (BioRad Laboratories, CA) to the protein solution and subsequent measurement at 595 nm with a spectrophotometer and a relative measure of protein concentration by a standard curve, keeping Bovine Serum Albumin (BSA 1X, 0.1 mg/ml) as standard.

For 500 µl determination, disposable polystyrene micro-

cuvettes were used, samples were mixed with Bradford reagent and waited for 2 minutes and measurement was read thereafter. A plot of O.D. 590 nm versus  $\mu\text{g}$  ( $\mu\text{g} = \mu\text{g}$ ) of BSA standard was made. Triplicates of the sample were made using the following calculation:

Bradford (ul)	Sterile Water (ul)	BSA100ug/ml (ul)	Total ug BSA
100	400	0	0
100	390	10	1
100	380	20	2
100	370	30	3
100	350	50	5
100	400	X ml sample protein	X

## 2.11. EMSA (Electrophoretic Mobility Shift Assay)

10x Binding buffer, prepared from NaCl, Tris HCl and RNase free water, was added to 1.5  $\mu\text{l}$  of radiolabelled RNA (~ 20,000 counts). RNA was incubated for 1 minute at 90 °C and transferred to room temperature for 3 minutes. Next, 2x Gel Shift buffer or Incubation buffer, prepared from Tris acetate and Magnesium acetate, was added to the same tube containing RNA. Final volume was adjusted with DEPC water. Now, incubation time given was 7 minutes to initiate RNA folding.

On ice, the purified proteins were kept for quantitation. Then, protein aliquots in different 1.5  $\mu\text{l}$  micro-centrifuge tubes, containing increasing protein concentrations, were thawed at room temperature. Then, NaCl,  $\text{Na}_2\text{HPO}_4$  and

NaH<sub>2</sub>PO<sub>4</sub> were added to these aliquots. Final volume was adjusted to same in all tubes, by adding DEPC water.

Next, RNA and protein were mixed at room temperature. RNA-protein reaction mixture was given mild orbital shake for 20 minutes, with 1.5 ml micro-centrifuge tube-tops sealed with parafilm. 10 µl of loading buffer, containing glycerol and bromophenol blue and β-mercaptoethanol, was added to make a final loading mixture. One 1.5 µl micro-centrifuge tube will have radiolabelled RNA and all ingredients in it, but the protein, as control for EMSA.

Final reaction mixture tubes were loaded on wells of a 5% polyacrylamide gel, prepared with 40% A: B (19: 1), TBE, MgCl<sub>2</sub>, APS and TEMED in distilled water. 0.5x TBE was the running buffer. RNA-protein complexes formed resulted in the retarded mobility in the gel and showed the shift. Contrastingly, free RNA migrated faster in the gel during electrophoresis for 2 hours at 100 volts. Gel shift results were analyzed by phosphor imager screen.

## CHAPTER III

### RESULTS AND DISCUSSION

#### 3.1. Compensatory Mutants of U12 and U6atac snRNAs At Helix I Intermolecular Interaction Region

To study the interactions of the snRNAs during minor class intron splicing, generation of compensatory mutants was required. Mutants could experimentally enable us to study the base-pairing interactions of the snRNAs. Base pairing between U2 and U6 snRNA components were previously demonstrated essential to form helix Ia and Ib as active sites of spliceosomal machinery. So, we mutated functionally analogous sites in U12 and U6atac snRNAs, to test if mutants abrogate splicing (**Figure 3.1**). The mutants were generated from the expression plasmid backgrounds of U12, U6atac and U4atac snRNAs, using mutagenic oligonucleotides. A schematic of the single nucleotide mutants of U12, U6atac and U4atac snRNAs is illustrated in **Figure 3.2**.

#### 3.2. Compensatory Mutants affect *in vivo* U12-dependent Intron Splicing Efficiency

The predicted helix Ia region of U12 snRNA WT spans



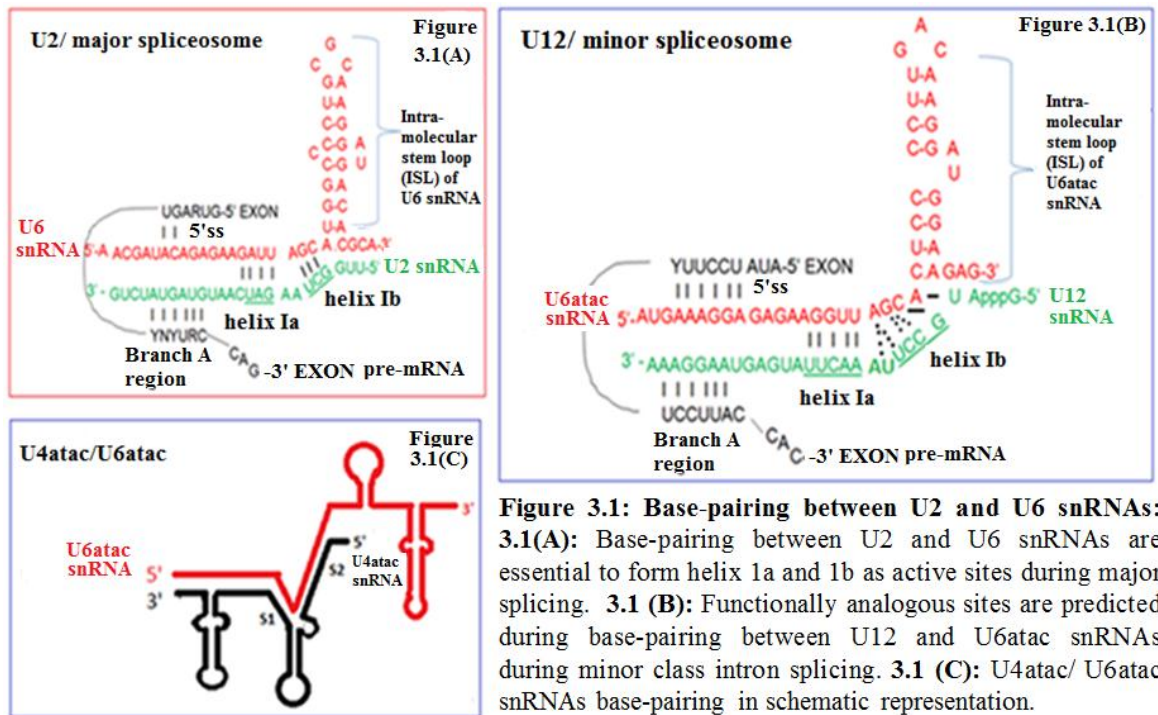
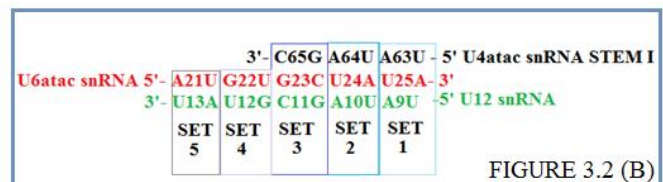
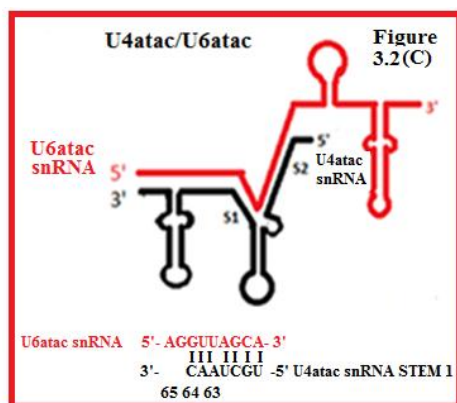

**Figure 3.1: Base-pairing between U2 and U6 snRNAs: 3.1(A):** Base-pairing between U2 and U6 snRNAs are essential to form helix 1a and 1b as active sites during major splicing. **3.1 (B):** Functionally analogous sites are predicted during base-pairing between U12 and U6atac snRNAs during minor class intron splicing. **3.1 (C):** U4atac/ U6atac snRNAs base-pairing in schematic representation.

between 9-13 nts (nucleotides). Five U12 snRNA mutants generated were named as, A9U, A10U, C11G, U12G and U13A. WT U6atac snRNA presumably uses 25-21 nts to base-pair with U12 snRNA helix Ia region. To test if predicted U12 snRNA interacts with corresponding U6atac snRNA, five compensatory mutants of U6atac snRNA were generated and named as, U25A, U24A, G23C, G22U and A21U (**Figure 3.2**). Likewise, 63-65 nts of U4atac snRNA Stem I region is predicted to base pair with U6atac snRNA along 25-23nts. So, three compensatory mutants of U4atac snRNA were generated and named as, A63U, A64U and C65G (**Figure 3.2**). For purpose of simplicity, each nucleotide of interacting U12 snRNA, that has been mutated to create a compensatory mutant, is grouped with the corresponding compensatory mutants of U6atac snRNA and U4atac snRNA. Then, a Set number is assigned to the team of 3 compensatory mutants. All team members grouped within a particular Set is predicted to rescue U12-dependent splicing upon co - transfection of all snRNAs which belong to that Set (**Figure 3.2**).

For example, U12 A9U mutant is expected to abolish U12-dependent splicing. On co-transfection with U6atac U25A and U4atac A63U mutant, the U12-dependent splicing by U12 A9U mutant is expected to be restored. Then, we can conclude that, the restoration of correct U12-dependent splicing to the U12 snRNA mutant is possible by compensatory mutant of U6atac snRNA and compensatory mutant of U4atac snRNA.

This is the strategy of proposed compensatory sequential base-pairing alterations. It allows us to test the effect of the alteration of one nucleotide in U12, U6atac and U4atac snRNAs on their function, *in vivo*. It will also prove if one nucleotide mutation in U12 snRNA is enough to impair splicing. Moreover, if splicing gets restored, when all compensatory mutants are put together, we will conclude that, these three snRNAs cross-talk with one another at their respective mutated nucleotide position (**Figure 3.2 C: Table**).



**Figure 3.2 :**  
**U4atac/U6atac snRNAs base-pairing in schematic representation:**  
**3.2 (A):** Predicted base-pairing between U4atac and U6atac snRNAs prior to U6atac/U12 snRNAs base-pairing at Helix 1a interaction region. **3.2 (B):** Construction of mutants of U12, U6atac and U4atac snRNAs at Helix 1a interaction region

U4atac snRNA	U6atac snRNA	U12 snRNA	Expected Outcome	SET NO.
A63U	-	-	-	<b>1</b>
A63U	U25A	-	-	
A63U	U25A	A9U	SPLICING	
A64U	-	-	-	<b>2</b>
A64U	U24A	-	-	
A64U	U24A	A10U	SPLICING	<b>3</b>
C65G	-	-	-	
C65G	G23C	-	-	
C65G	G23C	C11G	SPLICING	<b>4</b>
-	G22U	-	-	
-	G22U	U12G	SPLICING	<b>5</b>
-	A21U	-	-	
-	A21U	U13A	SPLICING	

**3.2 (C):** Tabular representation of the base-pairing of U12, U4atac and U6atac snRNAs at helix 1a interaction region along with their expected outcomes.

### **3.3. Compensatory Mutants of U12 and U6atac snRNAs At Helix Ib Intermolecular Interaction Region**

The predicted helix Ib region of U12 snRNA WT spans from 4-6 nts (nucleotides) (**Figure 3.3**). Three mutants generated from single nt. substitution at position 5 were named as, C5A, C5U and C5G. Three more mutants were generated from single nt. substitution at position 6 and named as, U6A, U6G and U6C. WT U6atac snRNA presumably uses 28-26 nts to base-pair with U12 snRNA helix Ib region. So, three compensatory mutants of U6atac snRNA were generated from single nt. substitution at position 27 and named as, G27U, G27C and G27A. Three more mutants generated from single nt. substitution at position 26 were named as, A26U, A26C and A26G. Likewise, 60-62 nts of U4atac snRNA Stem I region is predicted to base pair along 28-26 nts. of U6atac snRNA. So, three compensatory mutants of U4atac snRNA were generated from single nt. substitution at nt. position 61, and named as, C61A, C61G and C61U. Three more mutants were generated from single nt. substitution at position 62, and named as, U62A, U62G and U62C. A schematic representation (**Figure 3.3**) illustrates predicted base pairing of U12, U6atac and U4atac snRNAs at helix Ib. As done with helix Ia, likewise, a Set number was assigned to each team of interacting U12, U6atac and U4atac snRNAs compensatory mutants of helix Ib region. All team members grouped within a particular Set is predicted to rescue U12-dependent splicing upon co-transfection of all components belonging to that Set.

### **3.4. *In vivo* Genetic Suppression Assay Using P120 Mini-gene Intron F Can Detect Predicted Base Pairing of U12-U6atac and U6atac-U4atac snRNAs**

Controlling the spliceosomal machinery by nucleotide base- pairing interaction within the helix region could be an effective cellular strategy to

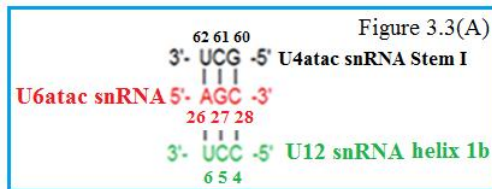

**Figure 3.3: Predicted base-pairing of U12, U6atac and U4atac snRNAs:**

**3.3 (A):** Predicted base-pairing between U12, U4atac and U6atac snRNAs at Helix 1b interaction region.

**3.3 (B):** Tabular representation of mutants of U12, U6atac and U4atac snRNAs constructed to check the base-pairing interactions at Helix 1b interaction region. The expected outcomes are listed when all three compensatory mutants will be transfected.

U4atac snRNA	U6atac snRNA	U12 snRNA	Expected Outcome	SET NO.
U62C	-	-	-	6
U62C	A26G	-	-	
U62C	A26G	U6C	SPLICING	
U62G	-	-	-	7
U62G	A26C	-	-	
U62G	A26C	U6G	SPLICING	
U62A	-	-	-	8
U62A	A26U	-	-	
U62A	A26U	U6A	SPLICING	
C61U	-	-	-	9
C61U	G27A	-	-	
C61U	G27A	C5G	SPLICING	
C61G	-	-	-	10
C61G	G27C	-	-	
C61G	G27C	C5U	SPLICING	
C61A	-	-	-	11
C61A	G27U	-	-	
C61A	G27U	C5A	SPLICING	

TABLE 3.3 (B)

regulate gene expression. The *in vivo* requirements for the nucleotide base pairing of U6atac, U12 and U4atac snRNAs for catalytic reactions during minor class intron splicing can be observed by the phenotypic expression of splice variants by performing the *in vivo* genetic suppression assay, where the P120 minigene with U12-dependent intron F was utilized (**Figure 3.4**).

To analyze the splicing of U12-dependent introns *in vivo*, Hall and Padgett expressed a fragment of the human P120 gene containing a 99 nucleotides long AT-AC intron in CHO cells, using a transient transfection assay. The transiently expressed AT-AC intron is correctly spliced in the transfected CHO cells. Suppression of a loss-of-function mutation in one molecule of a proposed base pairing RNA interaction by introduction of compensatory mutations in the other proposed RNA interacting molecule is the principle of the *in vivo* genetic suppression assay.

Our assay is similarly designed to study the existence of RNA-RNA base-pairing *in vivo* and also to detect the splice sites of the pre-mRNA. The co-expression of U11 Wild Type (Wt) snRNA with P120 Wt and U6atac snRNA Wt will

generate a single band product as fully spliced. The co-expression of suppressor allele of U11 snRNA carrying the GG6/7 CC compensatory mutation to base-pair with P120 5'ss mutation will eliminate splicing and will generate a single band as unspliced product. Only, the co-expression of suppressor allele of U11 snRNA carrying the GG6/7 CC compensatory mutation to base-pair with P120 5'ss mutation activate splicing *in vivo* when co-transfected with U6atac mutant suppressor allele carrying the GG 14/15 CC compensatory mutation and will restore the spliced band to almost WT level (**Figure 3.4C**).

Similarly, co-expression of suppressor allele of U11 snRNA carrying the GG6/7 CC compensatory mutation to base-pair with P120 Double Mutant with a 5'ss mutation as well as a branch point sequence mutation, will eliminate splicing and will generate a single band as unspliced product (**Figure 3.4C**). Only, the co-expression of suppressor allele of U11 snRNA carrying the GG6/7 CC compensatory mutation to base-pair with P120 5'ss mutation activate splicing *in vivo* when co-transfected with U6atac mutant suppressor allele carrying the GG 14/15 CC compensatory mutation and the U12 suppressor mutant snRNA and will restore the spliced band to almost WT level.

Using the *in vivo* genetic suppression principle, our complementary mutants were grouped in sets and were co-transfected in HeLa cells and were analyzed on 3% agarose gel, after RNA isolation followed by RT-PCR of the respective cDNAs, and, subsequent nested PCR steps. Optimization of the transient transfection conditions was performed to minimize non-specific products in each experiment. The results were verified by repeating the experiment, each time using appropriate controls in separate well on the gel. Along with the final *in vivo* products, the DNA ladder (100bp marker) is also loaded in one well to check the spliced product size.

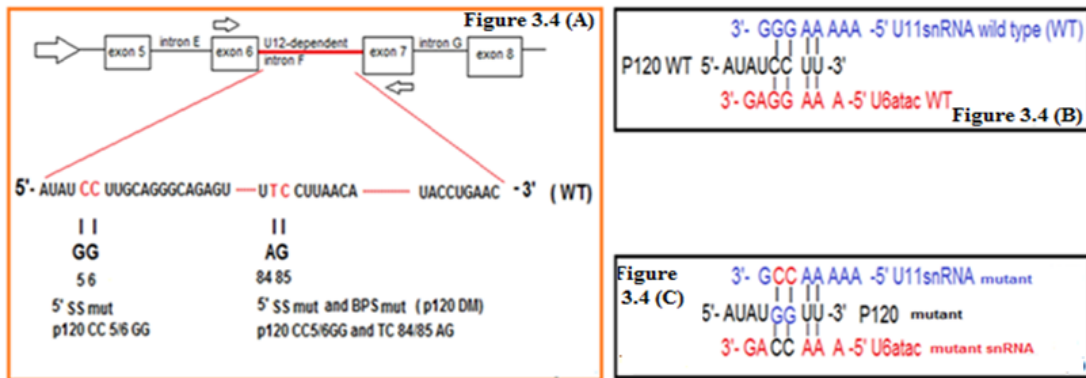

**Figure 3.4: Schematic representation of Human P120 mini-gene into pCB6 expression vector: 3.4(A):** Exons (open boxes) and U12 –dependent intron F are present in the mini-gene. Arrowheads show primer positions in RT-PCR. **3.4 (B):** Co-expression of WT of P120, U11 and U6atac snRNAs results in splicing. **3.4 (C) :** Co-expression of compensatory mutants of P120 5’ss, U11mutant (GG 6/7 CC and U6atac mutant (GG 14/15 CC) snRNAs result in splicing.

### 3.5. Single Nucleotide Mutants of U12, U6atac and U4atac snRNAs At Helix Ia Interaction Region Could Not Prevent Splicing

Splicing levels (**Figures 3.5 and 3.6**) indicate that single nucleotide mutation could not limit the activity of the U12-type splicing by inhibiting the base pair interaction at helix 1a region. Plenty of *in vivo* spliced products were detected using single complementary mutant, when negligible or no splicing was our expected outcome. The efficiency of U12-type of splicing was almost equivalent to that of normal splicing *in vivo* by substitution mutants on transfected constructs.

### 3.6. Splicing Efficiency Is Almost Unaltered With Single Nucleotide Mutation in Helix Ib Region of Interaction

Minimal or insignificant change was observed in the amount of splicing levels from the single nucleotide mutants in helix Ib region, as compared to the fully spliced mRNA.

This establishes the fact that, single nucleotide mutation was not enough to inhibit splicing (**Figures 3.6 and 3.7**).

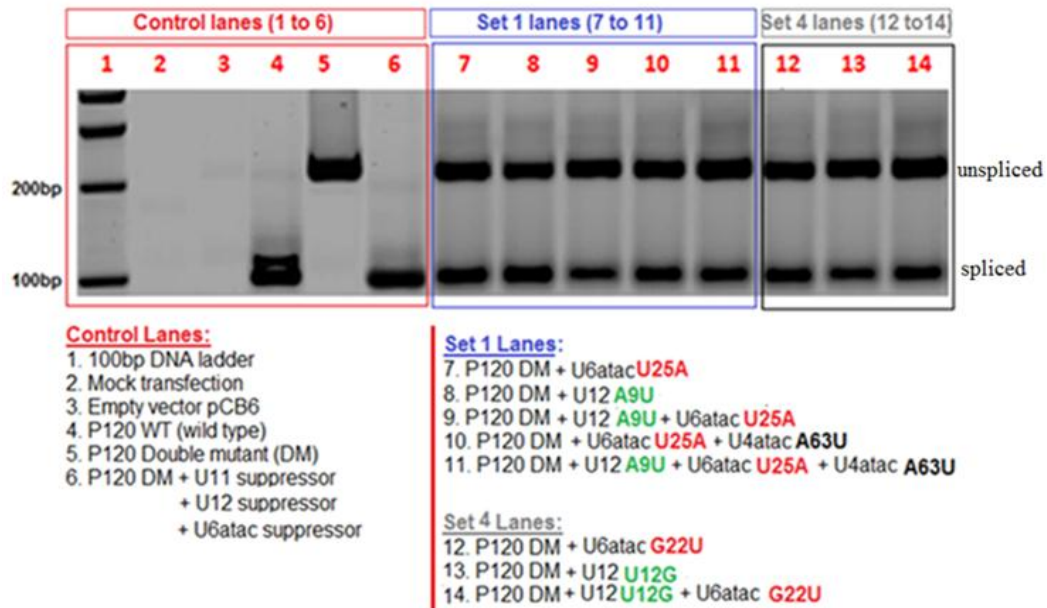

**Figure 3.5: *In vivo* single nucleotide splice variants of helix 1a region – interacting snRNAs:** After reverse transcription and PCR amplification, the products were analyzed by gel electrophoresis on a 3% agarose gel with 1X TBE.

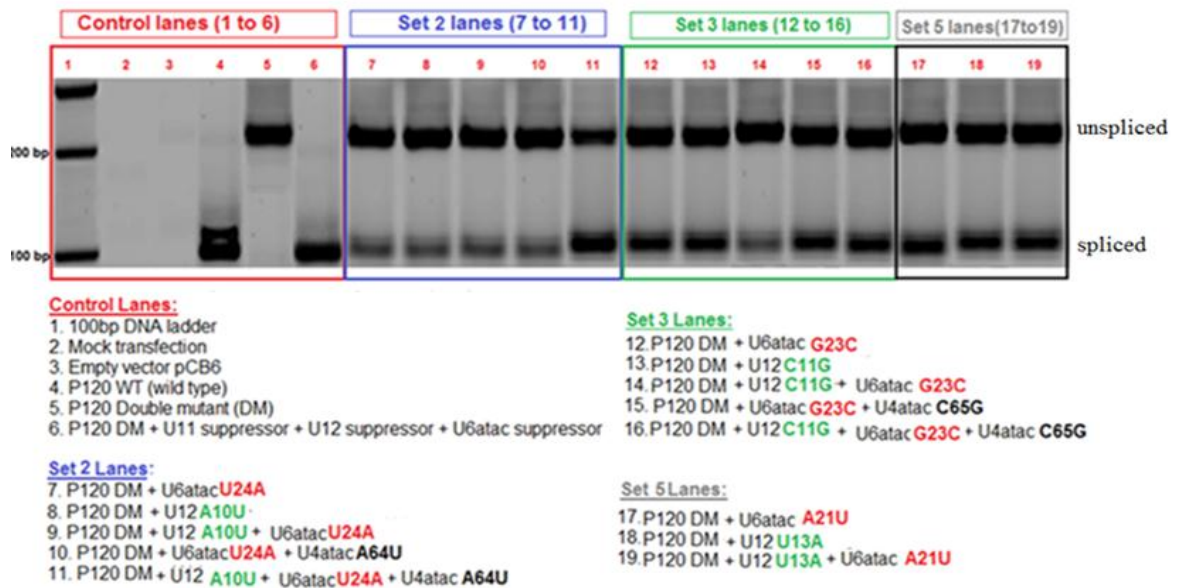

**Figure 3.6: *In vivo* single nucleotide splice variants of helix 1a region – interacting snRNAs:** After reverse transcription and PCR amplification, the products were analyzed by gel electrophoresis on a 3% agarose gel with 1X TBE.

### 3.7. Analyses of Single Mutations From *in vivo* Spliced Phenotypes

Our data show that base-pairing interactions occur between

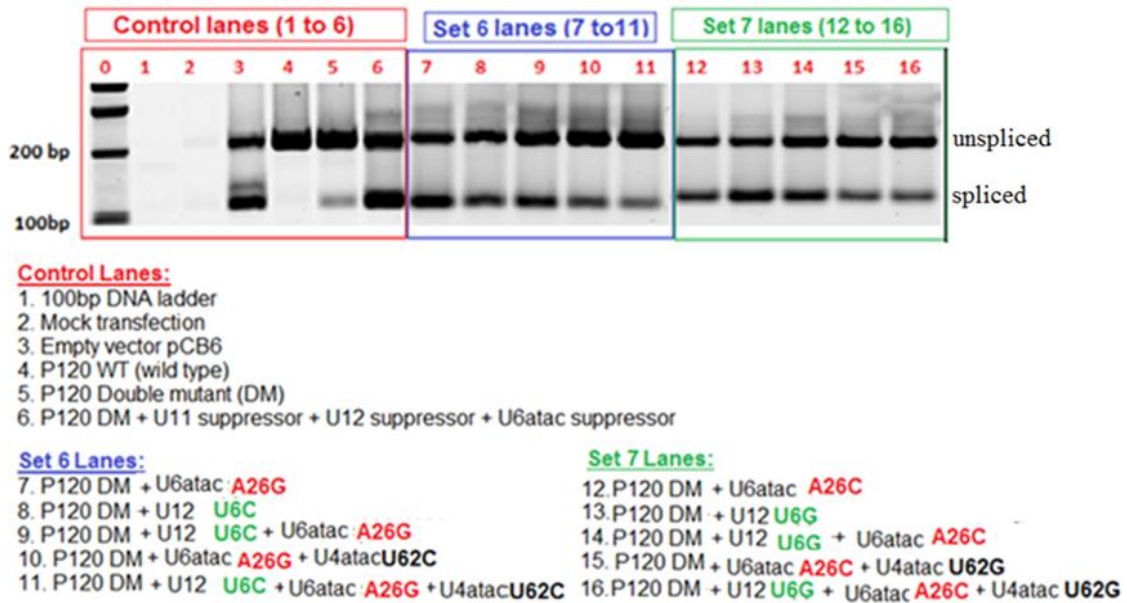

**Figure 3.7: *In vivo* single nucleotide splice variants of helix 1b region –interacting snRNAs (SETS 6 and 7):** After reverse transcription and PCR amplification, the products were analyzed by gel electrophoresis on a 3% agarose gel with 1X TBE.

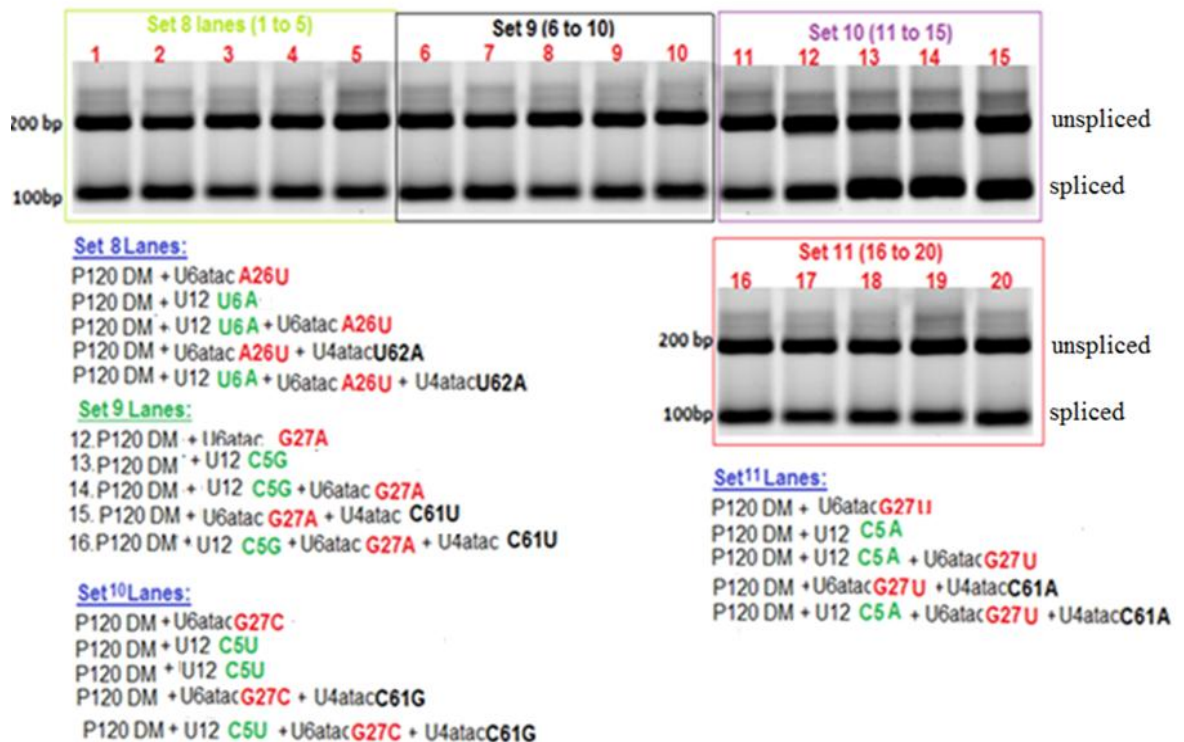

**Figure 3.8: *In vivo* single nucleotide splice variants of helix 1b region –interacting snRNAs (SETS 8, 9, 10 and 11):** After reverse transcription and PCR amplification, the products were analyzed by gel electrophoresis on a 3% agarose gel with 1X TBE.

U12 and U6atac snRNAs (**Figures 3.5, 3.6, 3.7 and 3.8**). Splicing could not be



completely eliminated with mutation of a single nucleotide at helix interaction region of any one of the participating snRNAs. The *in vivo* spliced phenotypes indicate that, the mutation of single nucleotide is not enough to abrogate splicing. None of the sets of compensatory mutants of U12, U6atac and U4atac snRNAs could completely eliminate splicing. Instead, most of the *in vivo* phenotypes show that single nucleotide mutation was tolerated with little or no splicing in each Set.

As expected, no band was observed in case of negative control (mock transfection). Wild type lane had completely spliced product. The co-expression of suppressor allele of U11 snRNA carrying the GG6/7 CC compensatory mutation, P120 Double mutant, U6atac mutant suppressor allele carrying the GG 14/15 CC compensatory mutation and U12 suppressor mutant snRNA, activated splicing *in vivo* and restored the spliced band to almost WT lane.

From the positive controls in the experiment, we could conclude that our *in vivo* splicing assay has worked. However, there was no significant change visible on the splicing efficiency in all Sets of single nucleotide mutant co-transfected. Unlike the *in vitro* splicing assay, where all intermediate stages and products of splicing could be resolved on same gel, using *in vivo* splicing system could only allow us to obtain information only from the final products of splicing. Moreover, the splicing reaction kinetics could also be studied and different complexes formed during splicing could also be identified by the *in vitro* splicing assay. So, an *in vitro* splicing assay is recommended which could reflect the situation observed *in vivo*.

Our results also suggest us to choose adjacently two nucleotide mutations in the interacting snRNAs and check if there is any obstruction of the splicing event with double nucleotide mutations in the region of the base-pairing interactions in helix Ia and Ib. Since RNA-RNA interactions are phylogenetically

conserved and are essential for splicing to occur, we hypothesize that, adjacent two nucleotide mutations in the interacting snRNAs might be sufficient to disrupt the Watson – Crick base pairing near helix region and therefore, will prevent splicing.

### **3.8. Double Nucleotide Mutations of U4atac, U6atac and U12 snRNAs In Helix Ia Region Inhibit *in vivo* U12-dependent Splicing**

To study the events of snRNAs during minor class intron splicing, it was necessary to recapitulate the splicing phenomenon by using adjacent two nucleotide mutations in the interacting snRNAs. Then, restoration of splicing in spite of adjacently two nucleotide changes will indicate that the mutation in interacting nucleotides is enough to stop splicing catalysis. On other hand, if splicing gets restored, when all compensatory mutants will be put together, we can conclude that, these three snRNAs cross-talk with one another at their respective mutated nucleotides positions.

The predicted helix Ia region of U12 snRNA WT spans from 9-13 nts (nucleotides), and, four mutants generated were named as, AA9/10UU, AC10/11UU, CU11/12GG, and UU12/13GA. WT U6atac snRNA presumably uses 25-21 nts to base-pair with U12 snRNA helix Ia region. So, four compensatory mutants of U6atac snRNA were generated and named as, UU24/25AA, GU23/24CA, GG22/23UC and AG21/22UU. Likewise, 63-65 nts of U4atac snRNA Stem I region is predicted to base pair with U6atac snRNA along 25-23nts. So, two compensatory mutants of U4atac snRNA were generated and named as, AC64/65UG and AA63/64UU. A schematic representation (**Figure 3.9**) of U12, U6atac and U4atac snRNAs illustrate their predicted base pairing. A Set Number was assigned to each group of interacting U12, U6atac and

U4atac snRNAs compensatory mutants. All mutants grouped within a particular Set are predicted to rescue U12-dependent splicing upon co-transfection of all components that belong to that Set.

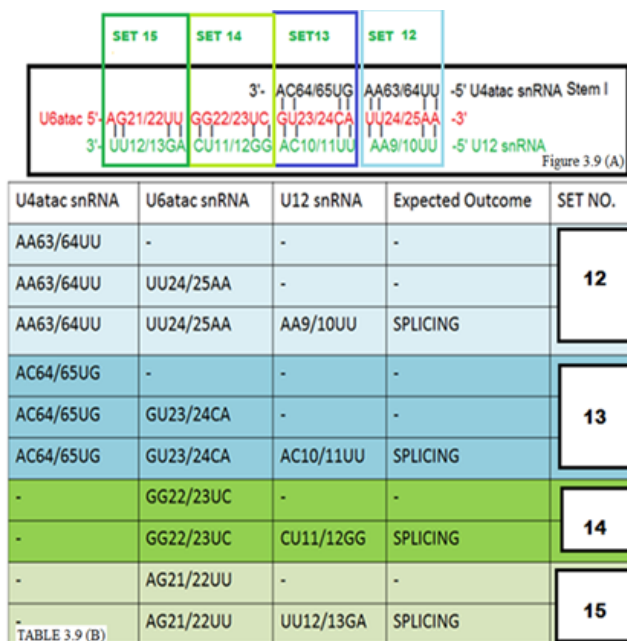

**Figure 3.9: Predicted base-pairing interactions of U12, U4atac and U6atac snRNAs along with the scheme of compensatory mutants generated:**

**3.9 (A):** Predicted base-pairing of U12, U6atac and U4atac snRNAs at helix 1a interaction region.

**3.9 (B):** Tabular representation of U12, U4atac and U6atac snRNA mutants constructed to check base-pairing interactions at Helix 1a region along with their expected outcomes when all compensatory double nucleotide mutants were co-transfected.

### 3.9. Analyses of *in vivo* Splicing Phenotypes from Double Mutations of U12, U6atac and U4atac snRNAs In Helix Interacting Region

One snRNA component bearing mutation in two adjacent nucleotides in the helix region of interaction was sufficient enough to inhibit splicing of a transfected construct. U12-type splicing does not occur if the *in vivo* environment is deficient of any one of the snRNA bearing at least two adjacent nucleotides mutation at the helix interaction region. However, the efficiency of splicing was significantly noticeable on co-transfection of all double nucleotide compensatory mutants on transfected constructs *in vivo* (Figure 3.10).

Our results could provide information to understand the structure – functional relationships in the interacting snRNAs at the helix region. The

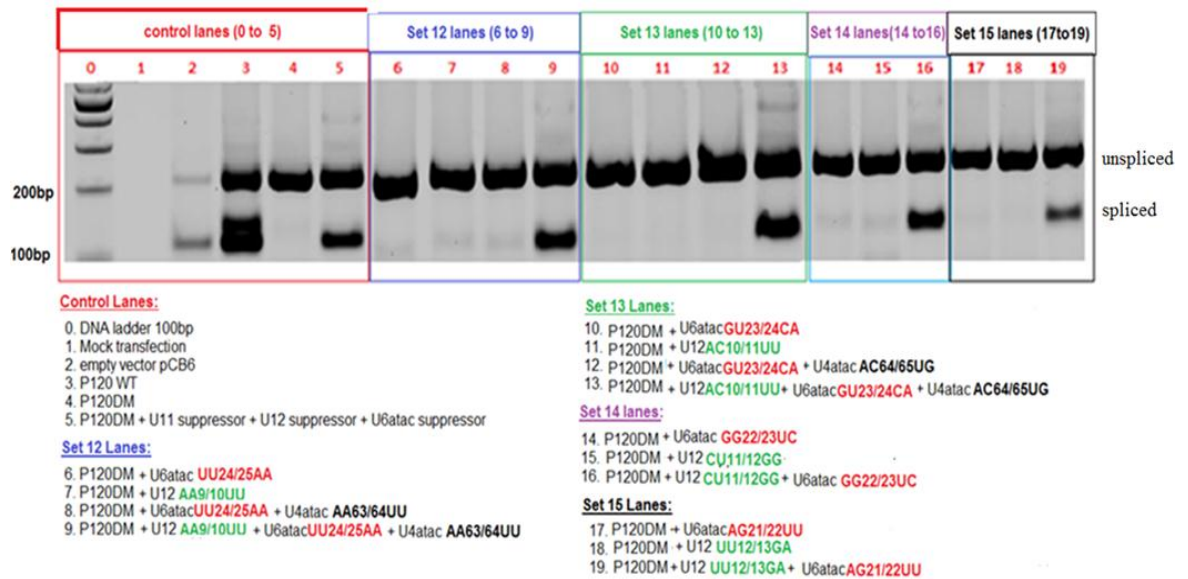

**Figure 3.10: *In vivo* double nucleotide splice variants of helix 1a region–interacting snRNAs (SETS 12, 13, 14 and 15):** After reverse transcription and PCR amplification, the products were analyzed by gel electrophoresis on a 3% agarose gel with 1X TBE.

base-pairing of, particularly, U12 and U6atac snRNAs are found to be more central to the *in vivo* splicing reactions. Although all the base pairs are important for function, the identities of the bases may not be so important, because the complementary sequences between U12 and U6atac and U4atac snRNAs could execute splicing reaction in an analogous fashion as performed by the WTs of U12 and U6atac and U4atac snRNAs.

### 3.10. Different snRNA Elements Might Share Common Minor Spliceosome Specific Components during U12-dependent Intron Splicing

Recent studies have suggested that, apart from the helix region, and with the pre-mRNA, U6atac and U12 snRNAs interact extensively with each other by Watson-Crick base pairing. Previous findings in our lab, using an *in vivo* genetic suppression assay, have identified that the Intra-molecular Stem Loop (ISL) structure of U6 snRNA can functionally replace U6atac snRNA ISL. Moreover, the 3'

RNA element of U6atac snRNA has been proved to be sufficient enough to guide U6 snRNA to minor spliceosome, indicating that, only 3' stem-loop (SL) of U6atac snRNA region is capable enough to activate minor class intron splicing (Shukla and Padgett, 2009).

From this information, we can presume that, RNA substructure(s) within the 3' RNA element of U6atac snRNA may have functional significance as critical component(s) which recruit spliceosomal components specifically to U12-dependent introns. Hence, disruption of such a critical RNA element would severely impair minor class intron splicing.

Summarizing the important break-through discoveries mentioned above, it is evident that, U6atac snRNA might be a good candidate to explain its interaction with some minor spliceosome-specific factors, most likely the components of U11/U12 di-snRNP and U4atac/ U5/U6atac tri-snRNPs, which must be required to bind the U12-type intron and prevent the minor spliceosome from being interfered by major spliceosome.

Recently, we have identified one potent critical substructure at 3' end of U6atac ISL region, between nucleotides 91 to 109, whose sequence alignment corresponds to U12 snRNA SLIII (nts. 109-125) (**Figure 3.11**). Furthermore, it is known that, human 18S U11/U12 snRNP exists as a di-snRNP and contains a set of seven proteins that are not found in U2 snRNP, suggesting that, the recognition of 5' splice and branch sites of U12-dependent introns is distinct from U2-dependent introns. Of these seven novel proteins, 65K RNA binding protein of U11-U12 di-snRNP complex is essential for cell viability (Will *et al.* 1999, Will *et al.* 2004) and forms a bridge between U11-59K protein and U12 snRNAs. It is also known to contain two RNA Recognition Motifs (RRMs) and is presumed to be involved in di-snRNP formation and

intron bridging. At this point, we also know that, the minor spliceosome tri-snRNP U4atac/U6atac.U5 forms similarly like major tri-snRNPs (Tarn and Steitz 1996a, Tarn and Steitz, 1996b). So, protein components of the U6atac/U4atac.U5 tri-snRNP do not differ from those in the major tri-snRNP (Luo *et al*, 1999, Nottrott *et al*, 2002, Schneider *et al*, 2002). On the contrary, U11 and U12 do not act as mono-particle but act as a di-snRNP. Since 65K protein of U11/U12 di-snRNP is only involved in minor splicing, so it is important to investigate that 65K protein might play a significant role during in recognizing and pairing of splice site and ensure the dynamicity as well as conservation of the minor splicing event.

65K RNA-BP appears to bind to apical stem-loop region of U12 SLIII and which has identical nucleotide sequences with U6atac ISL region, between nucleotides 91 to 109. Hence, we focused on two parameters: U12 snRNA SLIII nts (109-125) corresponding to 65K-C-RRM protein binding region, and sequence similarity of U6atac 3' element (nts. 91-109) with U12 snRNA SLIII (nts. 109-125).

We envision that sequence in U6atac snRNA identical to U12 snRNA might accomplish an important strategy involving the 65K protein, during a proper assembly of minor spliceosomal complex and a productive minor class intron splicing. The U6atac snRNA nucleotide sequences, from 91 to 109, within the 3' element might, therefore, be one critical sub-structure which could be indispensable for catalytically active spliceosomal rearrangements during snRNP assembly of U12-dependent intron splicing.

Since it is known that the 65K-C-RRM contains a well characterized domain binding with Stem III of U12 snRNA, we checked and confirmed that the 65K-C-RRM binds to 3' element of U6atac snRNA. The human U11/U12-65K protein contains one N- and one C-terminal RRM (RNA Recognition Motif) and a

central proline-rich region (**Figure 3.12**). It has been established by electrophoretic mobility shift assays (EMSA), that the GST-65K-C-RRM interacts with U12 snRNA (Benecke *et al*, 2005).

In order to check if the predicted interaction of GST-65K protein exists with U6atac snRNA, we used purified GST-65K-C-RRM and GST-65K-N-RRM and performed EMSA with  $^{32}\text{P}^*$  radiolabelled-U6atac WT snRNA. Our EMSA results validated that only 65K-C-RRM and not 65K-N-RRM could bind to U6atac snRNA. We can therefore predict that, the 3' RNA element of U6atac snRNA with the stem-loop structure, as well as any or multiple loop nucleotides and the loop-closing base-pair, play a critical role in the 65K/U6atac 3'SL interaction, and therefore can consequently affect splicing.

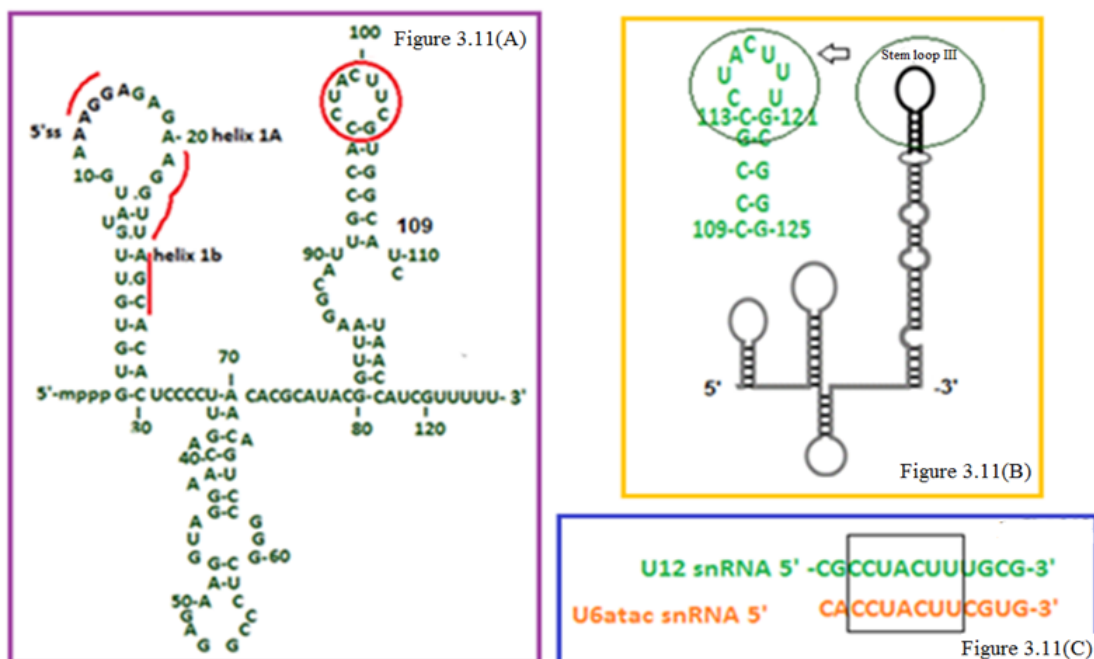
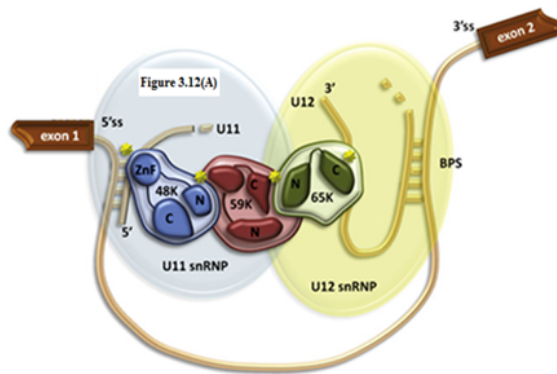

**Figure 3.11: Proposed secondary structure of U6atac snRNA:**

**3.11(A):** U6atac snRNA secondary structure with nucleotides (in red circle) in the 3' element identical to that in U12 snRNA Stem Loop III.

**3.11(B):** Proposed secondary structure of U12 snRNA showing nucleotides (109 to 125) identical to U6atac snRNA secondary structure from nucleotides circled in red.

**3.11(C):** U6atac snRNA has nucleotides from 91 to 109 in the 3' stem loop element with sequence alignment identical to U12 snRNA Stem Loop III nucleotides 109 to 125.



**Figure 3.12: Schematic representation of the interactions in A complex of the minor spliceosome:**

**3.12(A):** Known protein-protein and protein – RNA interactions are denoted by yellow stars. U12-65K protein interacts with U12 snRNA via its C-terminal RNA recognition motif (Benecke, 2005) and U12 snRNA is base-paired to BS (Frilander and Steitz, 1999). 65K-N-RRM binds to U11-59K-C-terminal domain (Benecke *et al*, 2005). Figure reference: H. Tidow, A. Andreeva, T.J. Rutherford, A.R. Fersht (2009).

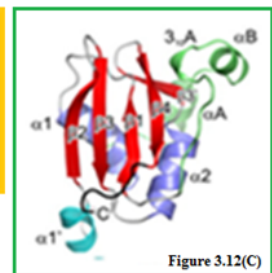
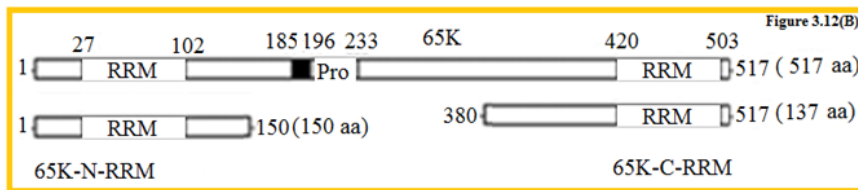

**3.12(B):** Schematic structure of 65K protein with RRM as proline rich region (Pro). 65K-N-RRM are schematically represented with their amino acid residues in brackets. Figure reference: Heike Benecke, Reinhard Luhrmann and Cindy L. Will (2005).

**3.12(C):** Stereo-ribbon plot of the 65K-C-RRM with alpha helices (in blue), beta strands (in red), additional alpha helix (65K, 380-517) in cyan and N-terminal expansion (380-417, in green). Figure reference: C. Netter, 2009).

### 3.11. Mutations Generated in U6atac snRNA 3' SL between Nucleotides 90 to 110 Can Detect Correct 65K-C-RRM Binding Sites

Once our EMSA data validated that the 65K-C-RRM binds to U6atac 3'SL, hence we decided to detect which nucleotide(s) or their alignment in U6atac snRNA are critical for binding to 65K-C-RRM protein. After making mutations within the nucleotide region 90 to 110 in U6atac snRNA 3' element, further EMSA analysis will help us detect which nucleotide or nucleotides comprising the loop or stem of the U6atac snRNA between the 90 to 110 positions are recognized by the 65K-C-RRM, or which nucleotides are crucial to contribute to 65K binding affinity.

To check the relative importance of the nucleotide region 90 to 110 in U6atac snRNA 3' element, we generated a pool of mutants of U6atac



snRNA, namely L1, L2, L3 and S1, S2, S3, S4, S5 and S6 (**Figure 3.13**).

L1, L2, L3 are the loop mutants and S1, S2, S3, S4, S5 and S6 are the stem mutants. Mutations of conserved loop nucleotides U (98), A(99) and C (100) were done to G (98), C(99) and G(100) respectively, by exchanging a pyrimidine with a purine and *vice versa* and three loop mutants U98G, A99C and C(100)G so generated, were named L1, L2 and L3, respectively.

The conserved C-G loop closing base- pair was mutated to U-A, and named as S1 (Stem mutant 1). By disrupting the stem region from nucleotides 104 to 109, Stem mutant 2 or S2 was generated to check if a stem-loop structure and not a single-stranded RNA alone are required for binding. The entire sequence of the stem was altered in Stem mutant 3 (S3). The orientation of the loop-closing C-G base pair was changed to G-C base pair to generate Stem mutant 4 or S4. All the stem nucleotides with the exception of the C-G loop-closing base pair were mutated to generate Stem mutant 5 or S5. The Stem mutant 6 was generated by disrupting the stem region from nucleotides 91 to 96, to check if a stem-loop structure and not a single-stranded RNA alone are required for binding (**Figure 3.13**).

### **3.12. Expected Outcomes from The U6atac snRNA (90-110) Nucleotides Mutations On 65K-C-RRM Protein Binding**

The purpose of making the mutations in the U6atac snRNA is to investigate if the stem, loop, or stem-loop structure, as well as, the identity of the several of the loop nucleotides and the loop-closing base-pair, plays a critical role in U12-dependent splicing. Mutations of conserved loop nucleotides, U (98), A(99) and C (100) in loop mutants, L1, L2 and L3, respectively are expected to abolish 65K-C-RRM-

RNA complex formation.

Conversion of the conserved C-G loop closing base-pair was mutated to U-A, in Stem mutant 1 is expected to show severe reduction in complex formation. Disruption of the stem in Stem mutant 2 and Stem mutant 6 will abolish any complex formation, because a defined stem loop structure and just not a single stranded RNA alone is probably not binding to 65K-C-RRM. Changing the orientation of the loop closing base pair, as done with Stem mutant 4, is presumed to have a moderate effect on protein binding, because the other structures remain unaltered. Finally, altering the entire sequence of the stem, which is done to generate Stem mutant 3, will leave the RNA with no protein binding sites. 65K-C-RRM will fail to recognize any sequence for RNA recognition and so, we expect that S5 will completely abolish 65K-C-RRM binding.

In summary, the mutations were designed to test the requirement of loops as well as stem of the predicted U6atac-65K-C-RRM interacting region in U12-dependent splicing.

### **3.13. U6atac snRNA Stem and Loop Nucleotides (90-110) Are Important In U12-dependent *in vivo* Splicing**

Under normal splicing conditions, minor class intron splicing will be unchallenged with involvement of WT U6atac snRNA interaction during the spliceosomal assembly reactions. We have identified the involvement of U6atac snRNA during *in vivo* genetic suppression assay for minor class intron splicing. However, the predicted critical substructure at 3' end of U6atac snRNA ISL region, between nucleotides 90 to 110, whose sequence alignment corresponds to U12 snRNA

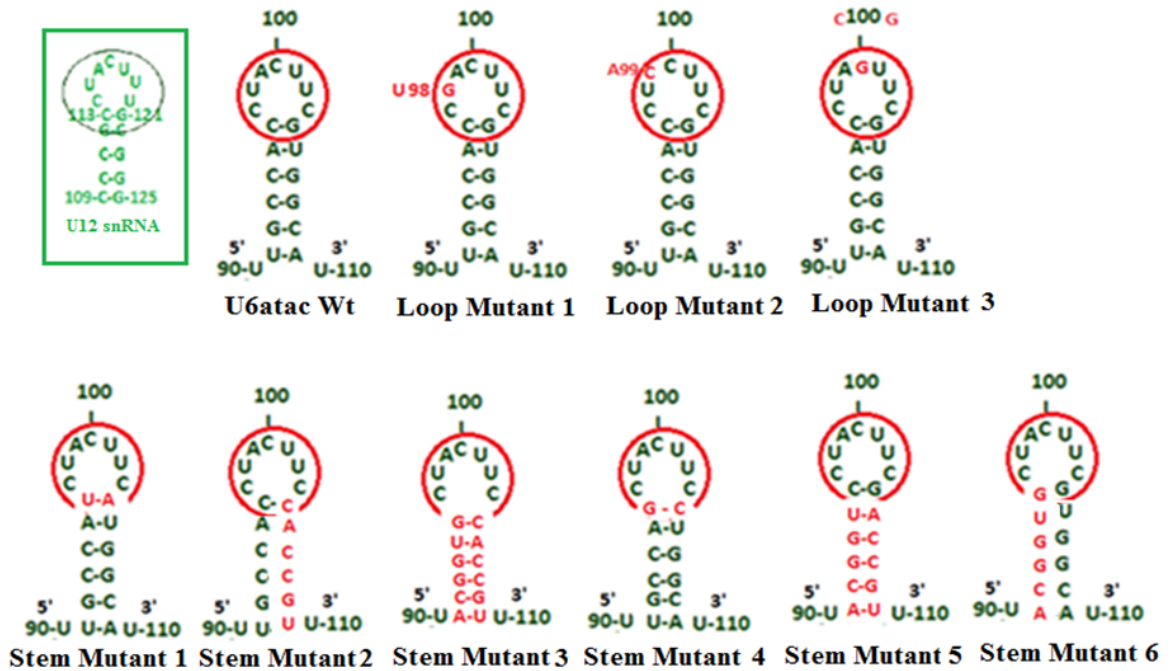

**Figure 3.13: Design of U6atac snRNA mutants:** Nucleotide sequences of the Wild Type (Wt) U6atac snRNA has nucleotides 91 to 109 in the 3' stem loop element which are identical to U12 snRNA Stem Loop III nucleotides highlighted in green in the left panel. L1, L2 and L3 are the U6atac snRNA Loop Mutants and S1, S2, S3, S4, S5 and S6 are the U6atac snRNA Stem Mutants constructed.

SLIII (nts. 109-125), might have a crucial role in splicing. At this point, we also know that of various unique, novel proteins of minor spliceosome, protein 65K-C-RRM contains RRM (RNA Recognition Motif), a well-characterized domain binding with Stem III of U12 snRNA. Focusing on these two parameters, we generated stem and loop mutations in U6atac snRNA 3' element (nts. 91-109). Then, we wanted to analyze the effect of U6atac snRNA stem and loop mutants by *in vivo* genetic suppression assays.

We wanted to check the U6atac mutation effect on U12-dependent splicing on a background of P120 mutant at 5' splice site (ss) only. We know that, U12snRNA is base-paired to BPS and U11 snRNA is based to 5'ss, but simultaneous recognition of 5'ss and BPs is required for minor class intron splicing. Hence, recruitment of U11 and U12 occurs as a di-snRNP complex, when 65K protein is a potent regulator of minor class intron splicing for its recognition of this di-snRNP

complex. We would like to investigate if mutants within the 3' U6atac snRNA element (nts.91-109) determine the levels of U12- dependent splicing. *In vivo* genetic suppression assay was performed using loop and stem mutants constructed in GG14/15CC background and the U11 suppressor and U12 suppressors were added accordingly as compensatory mutants to rescue splicing.

### **3.14. Analyses of *in vivo* Splicing Using U6atac Stem and Loop Mutants with P120 Mutant At 5' Splice Site**

In background of P120 5' splice site mutation, the stem and loop mutations in 3' U6atac snRNA element (nts.91-109) showed differential effects on splicing (**Figure 3.14**).

The 0 lane was loaded with 100bp DNA ladder to check the spliced and unspliced product sizes. As expected, no band was observed in case of mock transfection in lane 1 and in empty vector in lane 2. Wild type product in lane 3 had the expected band size as completely spliced product at 100 bp. P120 with 5' splice site mutation generated unspliced product in Lane 4. Co-expression of U11 snRNA carrying the GG6/7 CC compensatory mutation and P120 with 5' splice site mutation generated unspliced product in Lane 5. Co-expression of U6 snRNA carrying the GG14/15CC compensatory mutation and P120 with 5' splice site mutation generated less unspliced product and more of spliced product in Lane 6. Lane 7 showed that co-expression of all three suppressors, activated splicing *in vivo* and restored the spliced band to almost WT level, as in Lane 7.

Mutations of conserved loop nucleotides, U (98), A(99) and C (100) in loop mutants, L1, L2 and L3 , did not abolish splicing in Lanes 8,9 and 10 respectively.

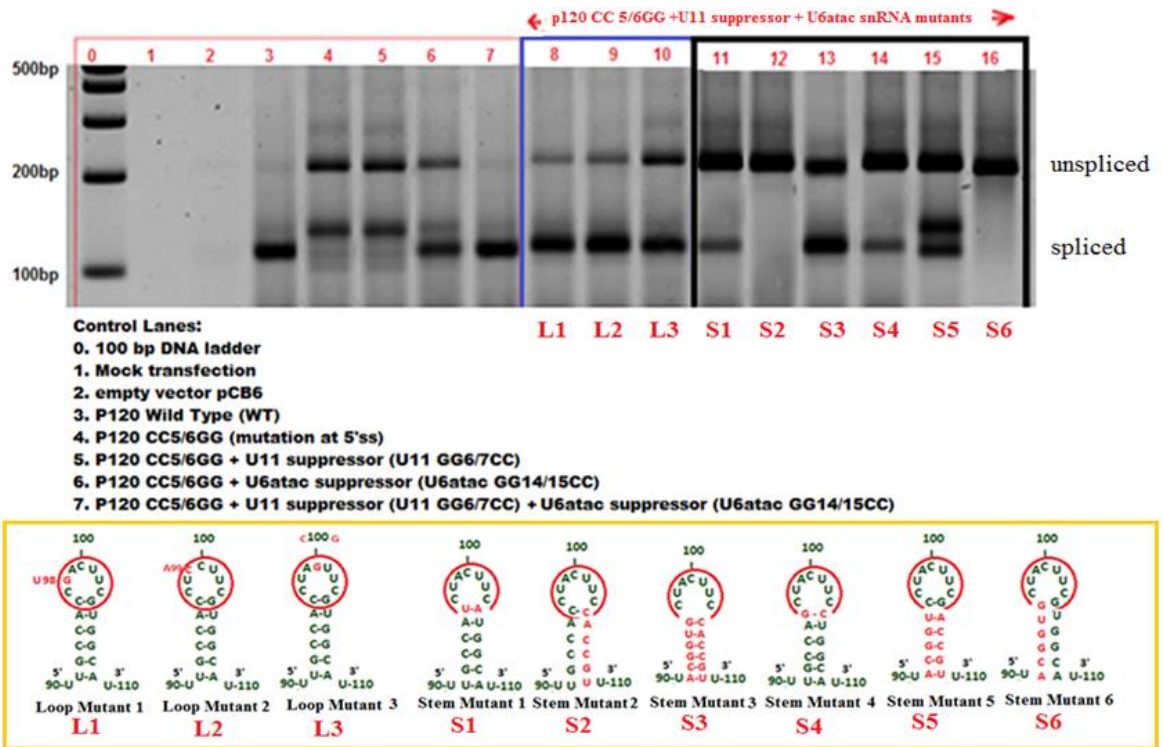

**Figure 3.14: *in vivo* spliced phenotypes of U6atac snRNA Stem and Loop mutants in p120 5'ss background:** L1, L2 and L3 are the U6atac snRNA Loop Mutants and S1, S2, S3, S4, S5 and S6 are the U6atac snRNA Stem Mutants constructed, as shown in gold panel.

In Stem mutant 1, where conserved C-G loop closing base-pair was mutated to U-A, there was reduction in spliced product in Lane 11. Disruption of the stem in Stem mutant 2 abolished splicing, as in Lane 12, probably because a defined stem loop structure and just not a single stranded RNA alone is required for splicing. Stem mutant 3 with entire sequence of the stem altered, show both spliced and unspliced products in Lane 13. Changing orientation of the loop closing base pair, as done with Stem mutant 4, showed more unspliced product in Lane 14. With all mutated stem nucleotides with the exception of C-G loop-closing base pair in Stem mutant 5, showed both spliced and unspliced products. Disruption of the stem in Stem mutant 6 abolished splicing, as in Lane 16.

## CHAPTER IV

### CONCLUSIONS AND FUTURE DIRECTIONS

#### 4.1. Conclusions

Using the single and double nucleotide mutations in snRNAs, we were able to utilize CHO cell-based transient transfection system to study pre-mRNA splicing and the U12-dependent minor class intron splicing, in specific. Our results showed that U12/U6atac helix Ia interaction ensured splicing, when adjacently two nucleotides complementary mutants of U12 snRNA and U6atac snRNA were co-expressed. This result could find resemblance with the U2/U6 helix Ia interaction, that exists in major class or U2-dependent intron splicing. U12/U6atac Helix Ib is predicted to have a structurally conserved AGC sequence situated before the U6atac Intra-molecular stem loop (ISL) region, almost identical to U6 ISL. However, single nucleotide mutations of U12, U4atac and U6atac snRNAs in helix region were not sufficient to prevent U12-dependent minor splicing. But, it could be well inferred from our data that, U12/ U6atac interaction at helix region was severely affected with double nucleotide mutants. Furthermore, 3' element of U6atac snRNA from nucleotides 91 to 109 has sequence similarity with Stem Loop III of U12snRNA from nucleotides 109 to

125. Of various unique novel proteins of minor spliceosome machinery, protein 65K-C-RRM contains a well-characterized domain binding to U12 snRNA SL III nts (109-125). We performed EMSA with 65K-N-RRM, 59K-N-RRM and 59K-C-RRM with U6atac snRNA WT, and, the gel shift assays validated that, only 65K-C-RRM binds to U6atac snRNA WT. Our data confirmed that U6atac 3' element nts. (91-109) binds to protein 65K-C- RRM.

Each nucleotide between positions 91 to 109 was mutated to generate single nucleotide mutants of U6atac snRNA. U12-dependent splicing was detected in varying levels for all mutants, suggesting that U6atac snRNA 3' element nts. (91-109) region is an essentially required component for U12-dependent intron splicing.

In conclusion, minor class or U12-dependent intron splicing is regulated by interplay of snRNPs following several unexplored mechanisms. In our work, regulatory mechanisms of U12, U11, U6atac and U4atac snRNAs were outlined. Further analyses of structure-function aspect of minor class U12-dependent intron splicing could significantly improve our understanding about their regulation in gene expression, coupled with their clinical significance, linked to the fact that, U12-dependent intron splicing co-exist with U2-dependent intron splicing.

## **4.2. Future Directions**

We want to determine splicing intermediates and detect free 5' exon, lariat intermediate with 3' exon, free lariat intermediate and spliced exons on the gel. *In vitro* assay will also ensure us to study the kinetics of splicing reaction, by manipulating the *in vitro* reactions at different time points, during complex formation steps. Furthermore, *in vitro* approach will also lead us to differentiate whether splicing

occurs by U2-dependent- or U12-dependent path, and, could provide insights about the coupling between the two. Inactivation of the snRNAs will be done using 2' O-methyl oligos. For blocking U2-dependent splicing, snRNAs in U2-system will be inactivated in the nuclear extracts. Since U2-system is manifold abundant than U12-system, we have to inactivate snRNAs of both U2- and U12- systems, in order to study what happens on blocking the U12 splicing components.

The only drawback with *in vitro* method is that, when almost every construct transfected in cells splices upon transfection *in vivo*, splicing ability is often limited for *in vitro* assays.

For assay validation and quantitation of gene expression, we will approach Quantitative Real-Time PCR (qRT-PCR) method for quantification and for studying kinetics of the reaction in early phases of PCR. Whereas, ethidium bromide staining is not precisely quantitative, the qRT-PCR will be highly sensitive to detect PCR amplicons at their exponential phase of the reaction. Hence, an accurate measurement of RNA will be obtained in an easier and more precise way. Once the expression levels and splicing efficiency can be quantitated, the SPSS package can be used for statistical analyses of each snRNA interaction and relative splicing efficiency can be calculated.

*In vitro* reconstitution study can be another approach to monitor the effects of reconstitution of functional snRNPs involved in U12-dependent intron splicing. By using a synthetic snRNA for *in vitro* run off transcription and subsequent incubation of the synthetic snRNA in HeLa cell extracts inactivated by pre-treatment, will give us information about the functional significance of a particular snRNA during U12-dependent intron splicing, which can be calculated from restoration of the splicing efficiency during *in vitro* assembly, in presence of ATP.



For improving the RNA-protein interaction, our GST-FP (65K-C-RRM) produced from pGEX-6P-1 vector with a PreScission Protease recognition site, can be cleaved from the GST tag either while bound to Glutathione sepharose chromatography media or in solution after elution. This will ensure stability of the target protein while simultaneously maximizing its interaction with its substrate RNA.

The interactions of stem and loop mutants of U6atac 3' RNA element with the U12 intron on a background of P120 DM bearing mutations, both at 5'ss and branch site, could also be studied along with their interactions with 65K-C-RRM protein.

## BIBLIOGRAPHY

1. Abelson, J., Trotta, C.R., and Li, H. 1998. tRNA splicing. *J. Biol. Chem.* 273: 12685–12688 doi: 10.1074/jbc.273.21.12685 May 22, 1998 *The Journal of Biological Chemistry*, 273, 12685-12688.
2. Abovich, N. and Rosbash, M. (1997) Cross-intron bridging interactions in the yeast commitment complex are conserved in mammals. *Cell* 89: 403-412.
3. Abramovitz, D.L., Friedman, R.A., and Pyle, A.M. 1996. Catalytic role of 2'-hydroxyl groups within a group II intron active site. *Science* 271: 1410–1413.
4. Achsel, T., Brahms, H., Kastner, B., Bachi, A., Wilm, M. and Lührmann, R. (1999) A doughnut shaped heteromer of human Sm-like proteins binds to the 3'-end of U6 snRNA, thereby facilitating U4/U6 duplex formation in vitro. *EMBO J.* 18: 5789-5802.
5. Alioto TS (2007) U12DB: a database of orthologous U12-type spliceosomal introns. *Nucleic Acids Res* 35: D110–115. 2007 Jan; 35(Database issue):D110-5. Epub 2006 Nov 1. PMID: 17082203 [PubMed].
6. Bartschat S, Samuelsson T. U12 type introns were lost at multiple occasions during evolution. *BMC Genomics.* 2010; 11:106. doi: 10.1186/1471- PMCID: PMC2846911.
7. Basu, M.K., Makalowski, W., Rogozin, I.B. and Koonin, E.V. (2008) U12 intron positions are more strongly conserved between animals and plants than U2 intron positions. *Biol. Direct* 3: 19.
8. Basu MK, Rogozin IB, Koonin EV. Primordial spliceosomal introns were probably U2-type. *Trends Genet* 2008, 24:525-528. *RNA.* 2005 Jul; 11(7):1095-107.

9. Behzadnia, N., Hartmuth, K., Will, C.L. and Lührmann, R. (2006) Functional spliceosomal A complexes can be assembled in vitro in the absence of a penta-snRNP. *RNA* 12: 1738-1746.
10. Bell, M., Schreiner, S., Damianov, A., Reddy, R. and Bindereif, A. (2002) p110, a novel human U6 snRNP protein and U4/U6 snRNP recycling factor. *EMBO J.* 21: 2724-2735.
11. Benecke, H., Lührmann, R. and Will, C.L. (2005) The U11/U12 snRNP 65K protein acts as a molecular bridge, binding the U12 snRNA and U11-59K protein. *EMBO J.* 24: 3057-3069.
12. Black, D.L., Chabot, B. and Steitz, J.A. (1985) U2 as well as U1 small nuclear ribonucleoproteins are involved in pre-messenger RNA splicing. *Cell* 42:737-750.
13. Black, D.L. and Steitz, J.A. (1986) Pre-mRNA splicing in vitro requires intact U4/U6 small nuclear ribonucleoprotein. *Cell* 46: 697-704.
14. Bonen, L. (1993) Trans-splicing of pre-mRNA in plants, animals, and protists. *FASEB J.* 7: 40-46.
15. Bonen, L. and Vogel, J. (2001) The ins and outs of group II introns. *Trends Genet.* 17: 322-331.
16. Borah, S., Wong, A.C. and Steitz, J.A. (2009) *Drosophila* hnRNP A1 homologs Hrp36/Hrp38 enhance U2-type versus U12-type splicing to regulate alternative splicing of the prospero twintron. *Proc. Natl. Acad. Sci.U.S.A.* 106: 2577-2582.
17. Bringmann, P., Appel, B., Rinke, J., Reuter, R., Theissen, H. and Lührmann, R. (1984) Evidence for the existence of snRNAs U4 and U6 in a single ribonucleoprotein complex and for their association by intermolecular base pairing. *EMBO J.* 3: 1357-1363.

18. Bringmann, P. and Lührmann, R.(1986). Purification of the individual snRNPs U1, U2, U5 and U4/U6 from HeLa cells and characterization of their protein constituents. *EMBO J.* 5: 3509-3516.
19. Burge CB, Padgett RA and Sharp PA (1998) Evolutionary fates and origins of U12-type introns. *Mol Cell*, 2, 773–785.
20. Burge, C.B., Tuschl, T. and Sharp, P.A. Splicing of precursors to mRNAs by the spliceosome in *The RNA world* (eds. Gesteland, R.F., Cech, T.R. and Atkins, J.F.) 2nd edition, pp. 525-560 (Cold Spring Harbor Laboratory Press, Cold Spring Harbor, NY, 1999).
21. Butcher S.E. and D.A. Brow. Towards understanding the catalytic core structure of the spliceosome. *Biochem Soc Trans.* 2005 Jun; 33(Pt 3):447-9. PMID: 15916538.[PubMed].
22. Cech, T.R. (1986) The generality of self-splicing RNA: relationship to nuclear mRNA splicing. *Cell* 44: 207-210.
23. Chanfreau, G., Jacquier, A. (1994) Catalytic site components common to both splicing steps of a group II intron. *Science* 266: 1383-1387.
24. Chang, D.D. and Sharp, P.A. (1989) Regulation by HIV Rev depends upon recognition of splice sites.*Cell* 59: 789-795.
25. Damianov, A., Schreiner, S. and Bindereif, A. (2004) Recycling of the U12-type spliceosome requires p110, a component of the U6atac snRNP. *Mol. Cell. Biol.* 24: 1700-1708.
26. Dávila López M, Rosenblad MA, Samuelsson T. Computational screen for spliceosomal RNA genes aids in defining the phylogenetic distribution of major and minor spliceosomal components. *Nucleic Acids Res.* 2008 May; 36(9):3001-10. Epub 2008 Apr 4.

27. Deckert, J., Hartmuth, K., Boehringer, D., Behzadnia, N., Will, C.L., Kastner, B., Stark, H., Urlaub, H. and Lührmann, R. (2006) protein composition and electron microscopy structure of affinity purified human spliceosomal B complexes isolated under physiological conditions. *Mol. Cell. Biol.* 26: 5528-5543.
28. Dietrich RC, Incorvaia R and Padgett RA (1997) Terminal intron dinucleotide sequences do not distinguish between U2- and U12-dependent introns. *Mol Cell*, 1, 151–160.
29. Dietrich, R.C., Shukla, G.C., Fuller, J.D. and Padgett, R.A. (2001) Alternative splicing of U12-dependent introns in vivo responds to purine-rich enhancers. *RNA* 7: 1378-1388.
30. Faustino, N.A. and Cooper, T.A. (2003) Pre-mRNA splicing and human disease. *Genes Dev.* 17: 419-437.
31. Fei Liu and Cheng-Xin Gong. Tau exon10 alternative splicing and tauopathies. *Molecular Neurodegeneration* 2008, 3:8 doi: 10.1186/1750-1326-38.
32. Fischer, U. and Lührmann, R. (1990) An essential signaling role for the m3G cap in the transport of U1 snRNP to the nucleus. *Science* 249: 786-790.
33. Fischer, U., Sumpter, V., Sekine, M., Satoh, T. and Lührmann, R. (1993) Nucleocytoplasmic transport of U snRNPs: definition of a nuclear location signal in the Sm core domain that binds a transport receptor independently of the m3G cap. *EMBO J.* 12: 573-583.
34. Franco Pagani, Michela Raponi, Francisco E Baralle. Synonymous mutations in CFTR exon 12 affect splicing and are not neutral in evolution. (2005) Volume: 102, Issue: 18, Publisher: National Academy of Sciences, Pages: 6368-6372.
35. Frilander, M.J. and Steitz, J.A. (1999) Initial recognition of U12-dependent introns requires both U11/5' splice-site and U12/branchpoint interactions. *Genes Dev.* 13: 851

-863.

36. Frilander, M.J. and Steitz, J.A. (2001) Dynamic exchanges of RNA interactions leading to catalytic core formation in the U12-dependent spliceosome. *Mol. Cell* 7: 217-226.
37. Gilbert, W. (1987) The exon theory of genes. *CSH Symp. Quant. Biol.* 52: 901-905.
38. Gordon PM and Piccirilli JA (2001) Metal ion coordination by the AGC triad in domain 5 contributes to group II intron catalysis. *Nature Struct Biol*, 8, 893–898.
39. Griffiths-Jones S, Saini HK, van Dongen S, Enright AJ (2008) miRBase: tools for microRNA genomics. *Nucleic Acids Res* 36:D154–D158.
40. Hall SL and Padgett RA (1994) Conserved sequences in a class of rare eukaryotic nuclear introns with non-consensus splice sites. *J Mol Biol*, 239, 357–365.
41. Hall SL and Padgett RA (1996) Requirement of U12 snRNA for in vivo splicing of a minor class of eukaryotic nuclear pre-mRNA introns. *Science*, 271, 1716–1718.
42. Hallegger, M., Llorian, M. and Smith, C.W.J. (2010) Alternative splicing: global insights. *FEBS J.* 277: 856-866.
43. Hashimoto, C. and Steitz, J.A. (1984) U4 and U6 RNAs coexist in a single small nuclear ribonucleoprotein particle. *Nucleic Acids Res.* 12: 3283-3293.
44. Hausner, T.P., Giglio, L.M. and Weiner, A.M. (1990) Evidence for base-pairing between mammalian U2 and U6 small nuclear ribonucleoprotein particles. *Genes Dev.* 4: 2146-2156.
45. Hilliker AK, Mefford MA, Staley JP (2007) U2 toggles iteratively between the stem IIa and stem IIc conformations to promote pre-mRNA splicing. *Genes Dev* 21: 821–834.
46. Huber, J., Cronshagen, U., Kadokura, M., Marshallsay, C., Wada, T., Sekine, M.

and Lührmann, R. (1998) Snurportin1, an m3G-cap-specific nuclear import receptor with a novel domain structure. *EMBO J.* 17: 4114-4126.

47. Huiling He, Sandya Liyanarachchi, Keiko Akagi, Rebecca Nagy, Jingfeng Li, Rosemary C. Dietrich, Wei Li, Nikhil Sebastian, Bernard Wen, Baozhong Xin, Jarnail Singh, Pearly Yan, Hansjuerg Alder, Eric Haan, Dagmar Wieczorek, Beate Albrecht, Erik Puffenberger, Heng Wang, Judith A. Westman, Richard A. Padgett, David E. Symer, and Albert de la Chapelle. Mutations in U4atac snRNA, a Component of the Minor Spliceosome, in the Developmental Disorder MOPD I. *Science* 8 April 2011: 238-240.

48. Incorvaia, R. and Padgett, R.A. (1998) Base pairing with U6atac snRNA is required for 5' splice site activation of U12-dependent introns in vivo. *RNA* 4: 709-718.

49. Jackson IJ (1991) A reappraisal of non-consensus mRNA splice sites. *Nucleic Acids Res*, 19, 3795–3798.

50. Jády, B.E., Darzacq, X., Tucker, K.E., Matera, A.G., Bertrand, E. and Kiss, T. (2003) Modification of Sm small nuclear RNAs occurs in the nucleoplasmic Cajal body following import from the cytoplasm. *EMBO J.* 22: 1878-1888.

51. Jarrell, K.A., Dietrich, R.C. and Perlman, P.S. (1988) Group II intron domain 5 facilitates a transsplicing reaction. *Mol. Cell. Biol.* 8: 2361-2366.

52. Jeffares, D.C., Mourier, T. and Penny, D. (2006) The biology of intron gain and loss. *Trends Genet.* 22:16-22.

53. Jurica, M.S., Licklider, L.J., Gygi, S.R., Grigorieff, N. and Moore, M.J. (2002) Purification and characterization of native spliceosomes suitable for three-dimensional structural analysis. *RNA* 8: 426-439.

54. Jurica, M.S. and Moore, M.J. (2003) Pre-mRNA splicing: awash in a sea of

proteins. *Mol. Cell* 12: 5-14.

55. Kolossova, I. and Padgett, R.A. (1997) U11 snRNA interacts in vivo with the 5' splice site of U12-dependent (AU-AC) pre-mRNA introns. *RNA* 3: 227-233.

56. Konarska, M.M. and Sharp, P.A. (1987). Interactions between small nuclear ribonucleoprotein particles in formation of spliceosomes. *Cell* 49: 763-774.

57. Koonin, E.V. (2006) The origin of introns and their role in eukaryogenesis: a compromise solution to the introns-early versus introns-late debate? *Biol. Direct* 1: 22.

58. Konforti BB, Abramovitz DL, Duarte CM, Karpeisky A, Beigelman L and Pyle AM (1998) Ribozyme catalysis from the major groove of group II intron domain 5. *Mol Cell*, 1, 1–20.

59. Krainer, A.R. and Maniatis, T. (1985) Multiple factors including the small nuclear ribonucleoproteins U1 and U2 are necessary for pre-mRNA splicing in vitro. *Cell* 42: 725-736.

60. Kruger, K., Grabowski, P.J., Zaug, A.J., Sands, J., Gottschling, D.E. and Cech, T.R. (1982) Self splicing RNA: autoexcision and autocyclization of the ribosomal RNA intervening sequence of *Tetrahymena*. *Cell* 31: 147-157.

61. Kunkel, G.R., Maser, R.L., Calvet, J.P. and Pederson, T. (1986) U6 small nuclear RNA is transcribed by RNA polymerase III. *Proc. Natl. Acad. Sci. U.S.A.* 83: 8575-8579.

62. Lamond, A.I. and Spector, D.L. (2003). Nuclear speckles: a model for nuclear organelles. *Nat. Rev. Mol. Cell Biol.* 4: 605-612.

63. Levine, A. and Durbin, R. 2001. A computational scan for U12-dependent introns in the human genome sequence. *Nucleic Acids Res.* 29: 4006–4013.

64. Lin, C.F., Mount, S.M., Jarmołowski, A. and Makalowski, W. (2010) Evolutionary dynamics of U12- type spliceosomal introns. *BMC Evol. Biol.* 10: 47.



65. Liu, F. and Gong, C. (2008) Tau exon 10 alternative splicing and tauopathies. *Mol Neurodegener* 3: 8.
66. Livio Pellizzoni. Chaperoning ribonucleoprotein biogenesis in health and disease. *EMBO reports* (2007) 8, 340 – 345. doi:10.1038/sj.embor.7400941.
67. Lopez AJ. 1998. Alternative splicing of pre-mRNA: Developmental consequences and mechanisms of regulation. *Annu Rev Genet* 32: 279–305.
68. López-Bigas, N., Audit, B., Ouzounis, C., Parra, G. and Guigó, R. (2005) Are splicing mutations the most frequent cause of hereditary disease? *EBS Lett.* 579: 1900-1903.
69. Lorković, Z.J., Lehner, R., Forstner, R. and Barta, A. (2005) Evolutionary conservation of minor U12-type spliceosome between plants and humans. *RNA* 11: 1095-1107.
70. Luo, H.R., Moreau, G.A., Levin, N. and Moore, M.J. (1999) The human Prp8 protein is a component of both U2- and U12-dependent spliceosomes. *RNA* 5:893-908.
71. Lynch M, Richardson AO: The evolution of spliceosomal introns. *Curr Opin Genet Dev* 2002, 12:701-710.
72. Madhani, H.D. and Guthrie, C. (1992) A novel base-pairing interaction between U2 and U6 snRNAs suggests a mechanism for the catalytic activation of the spliceosome. *Cell* 71: 803-817.
73. Makarov, E.M., Makarova, O.V., Urlaub, H., Gentzel, M., Will, C.L., Wilm, M. and Lührmann, R. (2002) Small nuclear ribonucleoprotein remodeling during catalytic activation of the spliceosome. *Science* 298: 2205-2208.
74. Makarova, O.V., Makarov, E.M., Liu, S., Vornlocher, H. and Lührmann, R. (2002) Protein 61K, encoded by a gene (PRPF31) linked to autosomal dominant retinitis pigmentosa, is required for U4/U6·U5 trisnRNP formation and pre-mRNA splicing.

EMBO J. 21: 1148-1157.

75. Malay Kumar Basu, Igor B. Rogozin, Oliver Deusch, Tal Dagan, William Martin and Eugene V. Koonin. Evolutionary Dynamics of Introns in Plastid-Derived Genes in Plants: Saturation Nearly Reached but Slow Intron Gain Continues. *Mol. Biol. Evol.* 25(1):111–119. (2008).

76. Malca, H., Shomron, N. and Ast, G. (2003) The U1 snRNP base pairs with the 5' splice site within a penta-snRNP complex. *Mol. Cell. Biol.* 23: 3442-3455.

77. Marz, M., Kirsten, T. and Stadler, P.F. (2008) Evolution of spliceosomal snRNA genes in metazoan animals. *J. Mol. Evol.* 67: 594-607.

78. Maschhoff, K.L. and Padgett, R.A. (1993) The stereochemical course of the first step of pre-mRNA splicing. *Nucleic Acids Res.* 21: 5456-5462.

79. Matera, A.G. and Ward, D.C. (1993) Nucleoplasmic organization of small nuclear ribonucleoproteins in cultured human cells. *J. Cell Biol.* 121: 715-727.

80. Mattaj, I.W. (1986) Cap hypermethylation of U snRNA is cytoplasmic and dependent on snRNP protein binding. *Cell* 46: 905-911.

81. Mefford MA, Staley JP. Evidence that U2/U6 helix I promotes both catalytic steps of pre-mRNA splicing and rearranges in between these steps. *RNA.* 2009 Jul; 15(7):1386-97. Epub 2009 May 20.

82. Montzka, K.A. and Steitz, J.A. (1988) Additional low-abundance human small nuclear ribonucleoproteins: U11, U12 etc. *Proc. Natl. Acad. Sci. U.S.A.* 85: 8885-8889.

83. Moore, M.J. and Sharp, P.A. (1993) Evidence for two active sites in the spliceosome provided by stereochemistry of pre-mRNA splicing. *Nature* 365: 364-368.

84. Moore, M.J. and Proudfoot, N.J. (2009) Pre-mRNA processing reaches back to

transcription and ahead to translation. *Cell* 136: 688-700.

85. Mount, S.M., Pettersson, I., Hinterberger, M., Karmas, A. and Steitz, J.A. (1983) The U1 small nuclear RNA-protein complex selectively binds a 5' splice site in vitro. *Cell* 33: 509-518.

86. Mount, S.M. and Salz, H.K. (2000) Pre-messenger RNA Processing Factors in the *Drosophila* Genome. *J. Cell Biol.* 150: 37F-44.

87. Mount, S.M., Gotea, V., Lin, C., Hernandez, K. and Makalowski, W. (2007) Spliceosomal small nuclear RNA genes in 11 insect genomes. *RNA* 13: 5-14.

88. Narayanan, U., Achsel, T., Lührmann, R. and Matera, A.G. (2004) Coupled in vitro import of UsnRNPs and SMN, the spinal muscular atrophy protein. *Mol. Cell* 16: 223-234.

89. Newman, A.J. and Norman, C. (1992) U5 snRNA interacts with exon sequences at 5' and 3' splice sites. *Cell* 68: 743-754.

90. Nottrott, S., Urlaub, H. and Lührmann, R. (2002) Hierarchical, clustered protein interactions with U4/U6 snRNA: a biochemical role for U4/U6 proteins. *EMBO J.* 21: 5527-5538.

91. Ohno, M., Segref, A., Bachi, A., Wilm, M. and Mattaj, I.W. (2000) PHAX, a mediator of U snRNA nuclear export whose activity is regulated by phosphorylation. *Cell* 101: 187-198.

92. Olga V. Makarova, Evgeny M. Makarov, Sunbin Liu, Hans-Peter Vornlocher and Reinhard Lührmann. Protein 61K, encoded by a gene (PRPF31) linked to autosomal dominant retinitis pigmentosa, is required for U4/U6·U5 tri-snRNP formation and pre-mRNA splicing. *EMBO Journal* (2002) 21, 1148 - 1157 doi:10.1093/emboj/21.5.1148.

93. Padgett, R.A., Konarska, M.M., Grabowski, P.J., Hardy, S.F. and Sharp, P.A. (1984) Lariat RNA's as intermediates and products in the splicing of messenger RNA

precursors. *Science* 225: 898-903.

94. Padgett, R.A. and Shukla, G.C. (2002) A revised model for U4atac/U6atac snRNA base pairing. *RNA* 8:125-128.

95. Pannone, B.K., Xue, D. and Wolin, S.L. (1998) A role for the yeast La protein in U6 snRNP assembly: evidence that the La protein is a molecular chaperone for RNA polymerase III transcripts. *EMBO J.* 17: 7442-7453.

96. Patel, A.A., McCarthy, M. and Steitz, J.A. (2002) The splicing of U12-type introns can be a rate limiting step in gene expression. *EMBO J.* 21: 3804-3815.

97. Patel, A.A., and Steitz, J.A. (2003). Splicing double: Insights from the second spliceosome. *Nat. Rev. Mol. Cell Biol.* 4, 960–970.

98. Patel, S.B. and Bellini, M. (2008) The assembly of a spliceosomal small nuclear ribonucleoprotein particle. *Nucleic Acids Res.* 36: 6482-6493.

99. Peebles, C.L., M. Zhang, P.S. Perlman and J.S. Franzen. (1995). Catalytically critical nucleotides in domain 5 of a group II intron. *Proceedings of the National Academy of Sciences, USA* 92: 4422-4426.

100. Pellizzoni L., Yong, J. and Dreyfuss, G. (2002) Essential role for the SMN complex in the specificity of snRNP assembly. *Science* 298: 1775-1779.

101. Perriman RJ, Ares Jr M (2007) Rearrangement of competing U2 RNA helices within the spliceosome promotes multiple steps in splicing. *Genes Dev* 21: 811–820.

102. Pessa HK, Frilander MJ. *Genetics*. Minor splicing, disrupted. *Science*. 2011 Apr 8; 332(6026):184-5.

103. Pozzoli, U., Sironi, M., Cagliani, R., Comi, G.P., Bardoni, A. and Bresolin, N. (2002) Comparative analysis of the human dystrophin and utrophin gene structures. *Genetics* 160: 793-798.

104. Qi Ma, Sunny Guin, Snehal S Padhye, Yong-Qing Zhou, Rui-Wen Zhang and

Ming-Hai Wang. Ribosomal Protein S6 Kinase (RSK)-2 as a central effector molecule in RON receptor tyrosine kinase mediated epithelial to mesenchymal transition induced by macrophage-stimulating protein. *Molecular Cancer* 2011, 10:66 doi: 10.1186/1476-4598-10-66.

105. Query, C.C., Moore, M.J. and Sharp, P.A. (1994) Branch nucleophile selection in pre-mRNA splicing: evidence for the bulged duplex model. *Genes Dev.* 8: 587-597.

106. Raghunathan, P.L. and Guthrie, C. (1998a) A spliceosomal recycling factor that reanneals U4 and U6 small nuclear ribonucleoprotein particles. *Science* 279: 857-860.

107. Raghunathan, P.L. and Guthrie, C. (1998b) RNA unwinding in U4/U6 snRNPs requires ATP hydrolysis and the DEIH-box splicing factor Brr2. *Current Biology* 8: 847-855.

108. Reed, R. (2003) Coupling transcription, splicing and mRNA export. *Curr. Opin. Cell Biol.* 15: 326-331.

109. Richard, H., Schulz, M.H., Sultan, M., Nürnberger, A., Schrunner, S., Balzereit, D., Dagand, E., Rasche, A., Lehrach, H., Vingron, M., Haas, S.A. and Yaspo, M. (2010). Prediction of alternative isoforms from exon expression levels in RNA-Seq experiments. *Nucleic Acids Res.* 38: e112.

110. Rinke, J. and Steitz, J.A. (1985) Association of the lupus antigen La with a subset of U6 snRNA molecules. *Nucleic Acids Res.* 13: 2617-2629.

111. Roy, S.W. and Gilbert, W. (2005) Rates of intron loss and gain: implications for early eukaryotic evolution. *Proc. Natl. Acad. Sci. U.S.A.* 102: 5773-5778.

112. Russell AG, Charette JM, Spencer DF, Gray MW. An early evolutionary origin for the minor spliceosome. *Nature.* 2006 Oct 19; 443(7113):863-6.

113. Salgado-Garrido, J., Bragado-Nilsson, E., Kandels-Lewis, S. and Séraphin, B.

- (1999) Sm and Smlike proteins assemble in two related complexes of deep evolutionary origin. *EMBO J.* 18: 3451-3462.
114. Sashital DG, Cornilescu G, McManus CJ, Brow DA, Butcher SE (2004) U2–U6 RNA folding reveals a group II intron-like domain and a four-helix junction. *Nat Struct Mol Biol* 11:1237–1242.
115. Sawa, H. and Abelson, J. (1992) Evidence for a base-pairing interaction between U6 small nuclear RNA and the 5' splice site during the splicing reaction in yeast. *Proc. Natl. Acad. Sci. U.S.A.* 89: 11269-11273.
116. Scamborova, P., Wong, A. and Steitz, J.A. (2004) An intronic enhancer regulates splicing of the twintron of *Drosophila melanogaster prospero* pre-mRNA by two different spliceosomes. *Mol. Cell. Biol.* 24: 1855-1869.
117. Schaffert, N., Hossbach, M., Heintzmann, R., Achsel, T. and Lührmann, R. (2004) RNAi knockdown of hPrp31 leads to an accumulation of U4/U6 di-snRNPs in Cajal bodies. *EMBO J.* 23: 3000-3009.
118. Schneider, C., Will, C.L., Makarova, O.V., Makarov, E.M. and Lührmann, R. (2002) HumanU4/U6.U5 and U4atac/U6atac.U5 tri-snRNPs exhibit similar protein compositions. *Mol. Cell. Biol.* 22: 3219-3229.
119. Schneider, C., Will, C.L., Brosius, J., Frilander, M.J. and Lührmann, R. (2004) Identification of an evolutionarily divergent U11 small nuclear ribonucleoprotein particle in *Drosophila*. *Proc. Natl. Acad. Sci. U.S.A.* 101: 9584-9589.
120. Séraphin, B. (1995) Sm and Sm-like proteins belong to a large family: identification of proteins of the U6 as well as the U1, U2, U4 and U5 snRNPs. *EMBO J.* 14: 2089-2098.
121. Sharp, P.A. (1985) On the origin of RNA splicing and introns. *Cell* 42: 397-400.
122. Sharp, P.A. (1991) "Five easy pieces". *Science* 254: 663.

123. Sharp PA and Burge CB (1997) Classification of introns: U2-type or U12-type. *Cell*, 91, 875–879.
124. Sheth, N., Roca, X., Hastings, M.L., Roeder, T., Krainer, A.R. and Sachidanandam, R. (2006). Comprehensive splice-site analysis using comparative genomics. *Nucleic Acids Res.* 34: 3955-3967.
125. Shimba, S. and Reddy, R. (1994) Purification of human U6 small nuclear RNA capping enzyme. Evidence for a common capping enzyme for gamma-monomethyl-capped small RNAs. *J. Biol. Chem.* 269:12419-12423.
126. Shukla, G.C. and Padgett, R.A. (2001) The intramolecular stem-loop structure of U6 snRNA can functionally replace the U6atac snRNA stem-loop. *RNA* 7: 94-105.
127. Shukla, G.C. and Padgett, R.A. (2002) A catalytically active group II intron domain 5 can function in the U12-dependent spliceosome. *Mol. Cell* 9: 1145-1150.
128. Shukla, G.C. and Padgett, R.A. (2004) U4 small nuclear RNA can function in both the major and minor spliceosomes. *Proc. Natl. Acad. Sci. U.S.A.* 101: 93-98.
129. Singh, J. and Padgett, R.A. (2009) Rates of in situ transcription and splicing in large human genes. *Nat. Struct. Mol. Biol.* 16: 1128-1133.
130. Sleeman, J.E. and Lamond, A.I. (1999) Newly assembled snRNPs associate with coiled bodies before speckles, suggesting a nuclear snRNP maturation pathway. *Curr. Biol.* 9: 1065-1074.
131. Smith, D.J., Query, C.C. and Konarska, M.M. (2008) "Nought may endure but mutability": spliceosome dynamics and the regulation of splicing. *Mol. Cell* 30: 657-666.
132. Sontheimer, E.J. and Steitz, J.A. (1993) The U5 and U6 small nuclear RNAs as active site components of the spliceosome. *Science* 262: 1989-1996.
133. Spiller, M.P., Boon, K.L., Reijns, M.A. and Beggs, J.D. (2007) The Lsm 2-8

determines nuclear localization of the spliceosomal U6 snRNA. *Nucleic Acids Res.* 35: 923-929.

134. Staley, J.P. and Guthrie, C. (1998) Mechanical devices of the spliceosome: Motors, clocks, springs, and things. *Cell* 92: 315-326.

135. Staley, J.P. and Guthrie, C. (1999) An RNA switch at the 5' splice site requires ATP and the DEAD box protein Prp28p. *Mol. Cell* 3: 55-64.

136. Stanek, D., Rader, S.D., Klingauf, M. and Neugebauer, K.M. (2003) Targeting of U4/U6 small nuclear RNP assembly factor SART3/p110 to Cajal bodies. *J. Cell Biol.* 160: 505-516.

137. Stanek, D., Pridalová-Hnilicová, J., Novotný, I., Huranová, M., Blazíková, M., Wen, X., Sapra, A.K. and Neugebauer, K.M. (2008) Spliceosomal small nuclear ribonucleoprotein particles repeatedly cycle through Cajal bodies. *Mol. Biol. Cell* 19: 2534-2543.

138. Stevens, S.W., Ryan, D.E., Ge, H.Y., Moore, R.E., Young, M.K., Lee, T.D. and Abelson, J. (2002). Composition and functional characterization of the yeast spliceosomal penta-snRNP. *Mol. Cell* 9: 31-44.

139. Tarn, W. and Steitz, J.A. (1996a) Highly divergent U4 and U6 small nuclear RNAs required for splicing rare AT-AC introns. *Science* 273: 1824-1832.

140. Tarn, W. and Steitz, J.A. (1996b) A novel spliceosome containing U11, U12 and U5 snRNPs excises a minor class (AT-AC) intron in vitro. *Cell* 84: 801-811.

141. Tarn, W., Yario, T.A. and Steitz, J.A. (1995) U12 snRNA in vertebrates: Evolutionary conservation of 5' sequences implicated in splicing of pre-mRNAs containing a minor class of introns. *RNA* 1: 644-656.

142. Tarn, W. and Steitz, J.A. (1997) Pre-mRNA splicing: the discovery of a new spliceosome doubles the challenge. *Trends Biochem. Sci.* 22: 132-137.



143. Tidow, H., Andreeva, A., Rutherford, T.J. and Fersht, A.R. (2009) Solution structure of the U11-48K CHHC zinc-finger domain that specifically binds the 5' splice site of U12-type introns. *Structure* 17: 294-302.
144. Toor, N., Keating, K.S., Taylor, S.D. and Pyle, A.M. (2008) Crystal structure of a self-spliced group II intron. *Science* 320: 77-82.
145. Turunen, J.J., Will, C.L., Grote, M., Lührmann, R. and Frilander, M.J. (2008) The U11-48K protein contacts the 5' splice site of U12-type introns and the U11-59K protein. *Mol. Cell. Biol.* 28: 3548-3560.
146. Tycowski, K.T., You, Z.H., Graham, P.J. and Steitz, J.A. (1998) Modification of U6 spliceosomal RNA is guided by other small RNAs. *Mol. Cell* 2: 629-638.
147. Uberto Pozzoli, Greg Elgar, Rachele Cagliani, Laura Riva, Giacomo P. Comi, Nereo Bresolin, Alessandra Bardoni and Manuela Sironi. Comparative Analysis of Vertebrate Dystrophin Loci Indicate Intron Gigantism as a Common Feature. doi: 10.1101/gr.776503 *Genome Res.* 2003. 13: 764-772 Copyright © 2003, by Cold Spring Harbor Laboratory Press.
148. Valadkhan, S. (2007) The spliceosome: a ribozyme at heart?. *Biol. Chem.* 388: 693-697.
149. Valadkhan, S. and Manley, J.L. (2001) Splicing-related catalysis by protein-free snRNAs. *Nature* 413: 701-707.
150. Valadkhan, S., Mohammadi, A., Jaladat, Y. and Geisler, S. (2009) Protein-free small nuclear RNAs catalyze a two-step splicing reaction. *Proc. Natl. Acad. Sci. U.S.A.* 106: 11901-11906.
151. Valcárcel, J., Gaur, R.K., Singh, R. and Green, M.R. (1996) Interaction of U2AF65 RS region with pre-mRNA of branch point and promotion base pairing with U2 snRNA. *Science* 273: 1706-1709.

152. Valencia P, Dias AP, Reed R. Splicing promotes rapid and efficient mRNA export in mammalian cells. *Proc Natl Acad Sci U S A*. March 4, 2008; 105 (9): 3386-91.
153. Villa T, Pleiss JA and Guthrie C (2002) Spliceosomal snRNAs: Mg<sup>2+</sup>-dependent chemistry at the catalytic core? *Cell*, 109, 149–152.
154. Wang, E.T., Sandberg, R., Luo, S., Khrebtkova, I., Zhang, L., Mayr, C., Kingsmore, S.F., Schroth, G.P. and Burge, C.B. (2008) Alternative isoform regulation in human tissue transcriptomes. *Nature* 456: 470-476.
155. Wassarman, D.A. and Steitz, J.A. (1992a) Interaction of small nuclear RNA's with precursor messenger RNA during in vitro splicing. *Science* 257: 1918-1925.
156. Wassarman, K.M. and Steitz, J.A. (1992b) The low-abundance U11 and U12 small nuclear ribonucleoproteins (snRNPs) interact to form a two-snRNP complex. *Mol. Cell. Biol.* 12: 1276-1285.
157. Will, C.L., Schneider, C., Reed, R. and Lührmann, R. (1999) Identification of both shared and distinct proteins in the major and minor spliceosomes. *Science* 284: 2003-2005.
158. Will, C.L. and Lührmann, R. (2001) Spliceosomal UsnRNP biogenesis, structure and function. *Curr. Opin. Cell Biol.* 13: 290-301.
159. Will, C.L., Schneider, C., Hossbach, M., Urlaub, H., Rauhut, R., Elbashir, S., Tuschl, T. and Lührmann, R. (2004) The human 18S U11/U12 snRNP contains a set of novel proteins not found in the U2- dependent spliceosome. *RNA* 10: 929-941.
160. Wu, Q., and Krainer, A.R.(1999). AT-AC pre-mRNA splicing mechanisms and conservation of minor introns in voltage-gated ion channel genes. *Mol. Cell. Biol.* 19, 3225–3236.
161. Yean S-L, Wuenschell G, Termini J, Lin R-J (2000) Metal-ion coordination by

U6 small nuclear RNA contributes to catalysis in the spliceosome. *Nature* 408: 881–884.

162. Yu, Y. and Steitz, J.A. (1997) Site-specific crosslinking of mammalian U11 and U6atac to the 5' splice site of an AT-AC intron. *Proc. Natl. Acad. Sci. U.S.A.* 94: 6030–6035.

163. Yu, Y., Shu, M., Narayanan, A., Terns, R.M., Terns, M.P. and Steitz, J.A. (2001) Internal modification of U2 small nuclear (sn)RNA occurs in nucleoli of *Xenopus* oocytes. *J. Cell Biol.* 152: 1279–1288.

164. Yamada T, K Tamura, T Aimi, and P Songsri. Self-splicing group I introns in eukaryotic viruses. *Nucleic Acids Res.* 1994 July 11; 22(13): 2532–2537. PMID: PMC308206.

165. Zamore, P.D. and Green, M.R. (1989) Identification, purification, and biochemical characterization of U2 small nuclear ribonucleoprotein auxiliary factor. *Proc. Natl. Acad. Sci. U.S.A.* 86: 9243–9247.

166. Zhu, W. and Brendel, V. 2003. Identification, characterization and molecular phylogeny of U12-dependent introns in the *Arabidopsis thaliana* genome. *Nucleic Acids Res.* 31: 4561–4572.

167. Zhou, Z., Licklider, L.J., Gygi, S.P. and Reed, R. (2002) Comprehensive proteomic analysis of the human spliceosome. *Nature* 419: 182–185.

## **APPENDIX**

**List of U11 Mutants generated: All primers are in 5' to 3' direction:**

**U11-1:** (DNA)-Phos-5' – AAATTCGGGAACTGTCGTGAG-3'

**U11-2:** (DNA)-Phos-5' –GAGATTTTCGGTTCATAATTTTT-3'

**U11-3:** (DNA)-Phos-5' –TTCGGCTTCTCGGTTGAGTGGCAC-3'

**U11-4:** (DNA)-Phos-5' –CTGTCGTGAGGCTGACACGTAGGG-3'