

Cleveland State University
EngagedScholarship@CSU



Electrical Engineering & Computer Science Faculty
Publications

Electrical Engineering & Computer Science
Department

3-2009

A Novel Discrete Dimming Ballast for Linear Fluorescent Lamps

Haiyan Wang

General Electric (GE) Consumer and Industrial, Lighting,, haiyan.wang@ge.com

Ana Vladan Stankovic

Cleveland State University, a.stankovic@csuohio.edu

Louis Nerone

General Electric (GE) Consumer and Industrial, Lighting,, louis.nerone@ge.com

David Kachmarik

General Electric (GE) Consumer and Industrial, Lighting,, david.kachmarik@ge.com

Follow this and additional works at: https://engagedscholarship.csuohio.edu/enece_facpub

 Part of the [Controls and Control Theory Commons](#), and the [Electrical and Electronics Commons](#)

How does access to this work benefit you? Let us know!

Publisher's Statement

© 2009 IEEE. Personal use of this material is permitted. Permission from IEEE must be obtained for all other users, including reprinting/ republishing this material for advertising or promotional purposes, creating new collective works for resale or redistribution to servers or lists, or reuse of any copyrighted components of this work in other works.

Original Citation

Haiyan, W., Stankovic, A. V., Nerone, L., & Kachmarik, D. (2009). A novel discrete dimming ballast for linear fluorescent lamps. *IEEE Transactions on Power Electronics*, 24, 6, 1453-1462.

Repository Citation

Wang, Haiyan; Stankovic, Ana Vladan; Nerone, Louis; and Kachmarik, David, "A Novel Discrete Dimming Ballast for Linear Fluorescent Lamps" (2009). *Electrical Engineering & Computer Science Faculty Publications*. 110.

https://engagedscholarship.csuohio.edu/enece_facpub/110

This Article is brought to you for free and open access by the Electrical Engineering & Computer Science Department at EngagedScholarship@CSU. It has been accepted for inclusion in Electrical Engineering & Computer Science Faculty Publications by an authorized administrator of EngagedScholarship@CSU. For more information, please contact library.es@csuohio.edu.

A Novel Discrete Dimming Ballast for Linear Fluorescent Lamps

Haiyan Wang, Ana Vladan Stankovic, *Member, IEEE*, Louis Nerone, *Senior Member, IEEE*, and David Kachmarik

Abstract—A novel discrete dimming ballast for linear fluorescent lamps is proposed in this paper. A proposed dimming control circuit is combined with a ballast module for multiple lamps to realize control of three discrete lighting levels. Compared with conventional step dimming or ON-OFF control methods, the proposed discrete dimming method has the following advantages: 1) digital signal is generated by the dimming control circuit to control the lamps' turn-ON and -OFF, which makes the system more reliable and integrated; 2) the proposed discrete dimming system replaces relays, which are necessary in conventional lamp ON-OFF control, and therefore decreases the system cost; 3) the proposed dimming ballast can be installed by keeping the original wiring system. This makes the upgrading of a lighting system more effective and efficient; 4) the dimming control circuit also provides a good isolation for operating the low-voltage wall switches by hand safely. Both theoretical, simulation, and experimental results are in good agreement.

Index Terms—Lighting, lighting control.

I. INTRODUCTION

LIGHTING consumes 25%–30% of energy in commercial buildings, and it is a primary source of heat gain and waste. Concerned about energy and budget, many companies are actively upgrading their lighting systems. A comfortable lighting system can also improve the worker's productivity and company's profitability. Dimming technology has been extensively analyzed and developed over the last decade, especially in the arc discharge lamp category [1]–[5]. Dimming control is usually employed to align the lighting levels with human needs as well as to save the energy. Compared with magnetic ballast, the electronic ballast reduces the energy consumption by 15%–20%. Furthermore, dimming capability is utilized to obtain more than 50% energy saving for the lighting system relative to a nondimming system.

For a linear fluorescent lamp, when dimmed over a full range without a reduction in lamp life, its cathode voltage must be maintained while the lamp arc current is reduced. So, the rapid start mode is suitable for the fluorescent lamp. In the rapid start mode, the ballast continuously heats the filaments. There are many methods to adjust the light levels of the lamp and realize

the dimming function. Basically, there are two ways to adjust the lighting levels: continuous dimming and discrete dimming. Continuous dimming ballast permits the light output of the lamps to be continuously controlled over a range of approximately 1%–100% of the full light output [9]–[11]. As an alternative to the continuous dimming, the discrete dimming method provides the discrete reduction in the lighting output. It is advantageous since the dimming can be performed for desired constant brightness in a simpler manner. For nonincandescent lighting systems, there are two different methods to provide the discrete dimming (step-dimming). The first method is called bilevel switching. The lamps are connected to different switching circuits so that the switches and relays turn them on and off directly. The second method is based on the ballast design for this specific purpose. Discrete dimming ballast based on occupancy sensors or other switching methods can control light level between low power and full power. This kind of dimming ballast is not very efficient because it provides different light output levels by keeping the lamps ON.

In this paper, a new concept for discrete dimming is proposed. The proposed discrete dimming ballast includes a novel dimming control circuit and an electronic ballast module. The electronic ballast module consists of a nondimming universal power factor correction (PFC) circuit, which drives three fluorescent lamps by three complementary half-bridge inverters. The proposed discrete dimming ballast has the following advantages as compared to the traditional discrete dimming system.

- 1) ON-OFF operation of the inverters within the ballast module is controlled by digital signals that are provided by a built-in dimming control circuit. This makes the control system more integrated and reliable.
- 2) The relays that are used in the conventional discrete dimming circuit have been eliminated. This makes the overall system cost-effective.
- 3) The proposed discrete dimming ballast can be installed by keeping the original wiring system. The wiring diagrams of the conventional lighting system and the proposed dimming system are shown in Fig. 1. It can be seen that there is no need to change the original wiring. This is a benefit since the existing systems can be easily upgraded.
- 4) The proposed discrete dimming control circuit provides a good isolation, so that the users can operate the wall switches by hand safely.
- 5) A dimming function is realized by turning off the lamps completely. This makes the overall system efficient.

The proposed discrete dimming ballast has been built in the laboratory. Both simulation results and experimental results

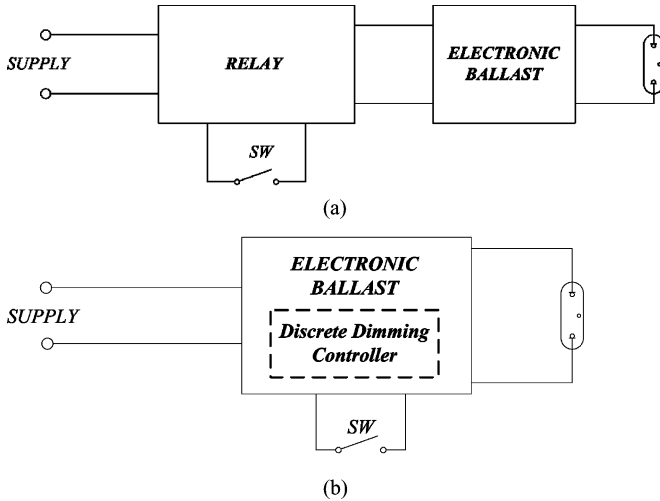

Fig. 1. (a) Conventional lighting system. (b) Proposed dimming system.

prove that the proposed discrete dimming ballast is stable, efficient, and reliable while providing three discrete lighting levels.

II. DISCRETE DIMMING BALLAST

Discrete dimming method provides discrete reductions in lighting output. For example, in a system with three lamps, one switch may operate the center lamp while another switch operates the other two outer lamps. This arrangement provides three lighting levels by turning one lamp on, two lamps on, and all three lamps on. As mentioned before, for the fluorescent lighting system, the bilevel switching circuit and the discrete dimming ballast are two ways to realize the discrete dimming. Discrete dimming ballast occupies an intermediate position in the array of energy saving ballast options. It offers more light control and energy savings than the nondimming ballast, but costs less than the continuous dimming ballast. Conventional discrete dimming ballast uses occupancy sensors to control lighting levels.

Unlike the conventional discrete dimming ballast or ON-OFF control method, the proposed dimming ballast consists of a ballast module for multiple lamps and a discrete dimming control circuit. The discrete dimming control circuit is built in the ballast module to control the ON-OFF operation of the inverters digitally. The dimming control circuit communicates with the wall switches directly without any need to use relays. Compared with the relays, the cost of the proposed dimming control circuit is much lower. The dimming control circuit also provides good isolation. The proposed discrete dimming ballast is installed by keeping the original wiring system. No new power wires are required; thus, the installment cost is lower. This would be the most efficient way to upgrade the lighting system.

The proposed discrete dimming ballast consists of the ballast module shown in Fig. 2 and the control circuit shown in Fig. 3(a).

The electronic ballast module has three complementary self-oscillating half-bridge inverters connected in parallel to drive three fluorescent lamps at the same time. It is mainly composed of the following stages: the electromagnetic interference (EMI)

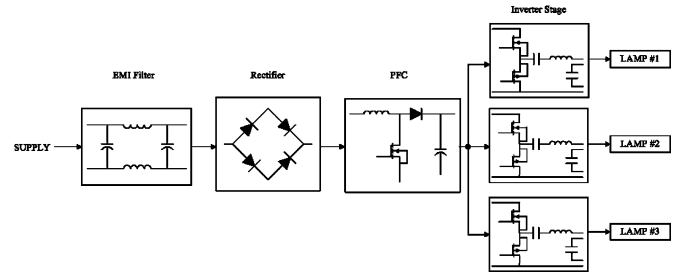

Fig. 2. Block diagram of the ballast module.

stage, the rectifier stage, the high-PFC stage [6], and three complementary half-bridge inverters that drive the three lamps, respectively [7]. The complementary class D inverter has a simple passive gate control system with triggerless starting that drives a complementary, source-connected pair of MOSFETs. Fig. 2 shows the block diagram of the ballast module.

The ON-OFF operation of the lamps is realized by the ON-OFF operation of the half-bridge inverters. Normally, the analog signals are used to operate the half-bridge inverters. However, digital signal control makes the circuit integrated and more efficient. Electromagnetic relay switches can be used, but they are bulky due to their large size, and are generally slow. Although solid-state relays are another choice, they are, however, expensive. Furthermore, the power dissipation occurs when the relay is ON, and thus, the efficiency of the circuit is decreased.

The proposed dimming control circuit consists of a shutdown circuit [8], which connects to the drive circuit of the half-bridge inverter to turn off the lamp with a digital control circuit. The shutdown circuit includes a diode and a switch. The digital control circuit can provide a digital signal to control the shutdown circuit. The digital control circuit consists of a high-frequency rectangular signal generator, momentary switches, charge pump circuits, and a flip-flop. The block diagram of the proposed dimming control circuit is shown in Fig. 3(a).

The electronic ballast consists of three inverters, so three shutdown circuits are used to control three inverters. Shutdown circuit 1 controls lamp #1, shutdown circuit 2 controls lamp #2, and shutdown circuit 3 controls lamp #3. Since three lighting levels are required, two digital signals are needed for these three shutdown circuits. One signal controls the shutdown circuit 2 and another signal controls both the shutdown circuit 1 and the shutdown circuit 3.

Signal generator generates a high-frequency rectangular voltage. Four low-voltage momentary switches are used to obtain three lighting levels. Once the momentary switch is pressed, the high-frequency rectangular voltage will apply to the charge pump circuit. Then, high-level output voltage will be achieved. This high-level voltage will set or reset the flip-flop chip. The output signal of flip-flop chip is just used to control the switch of the shutdown circuit.

According to the logic control of the dual flip-flop chip, switch SW1 is used to turn off lamp #2, the center lamp, and SW2 can turn it on. For the outer two lamps, lamp #1 and lamp #3, a generated digital signal will control the shutdown circuit 1 and the shutdown circuit 3. Thus, switch SW3 will turn off the outer

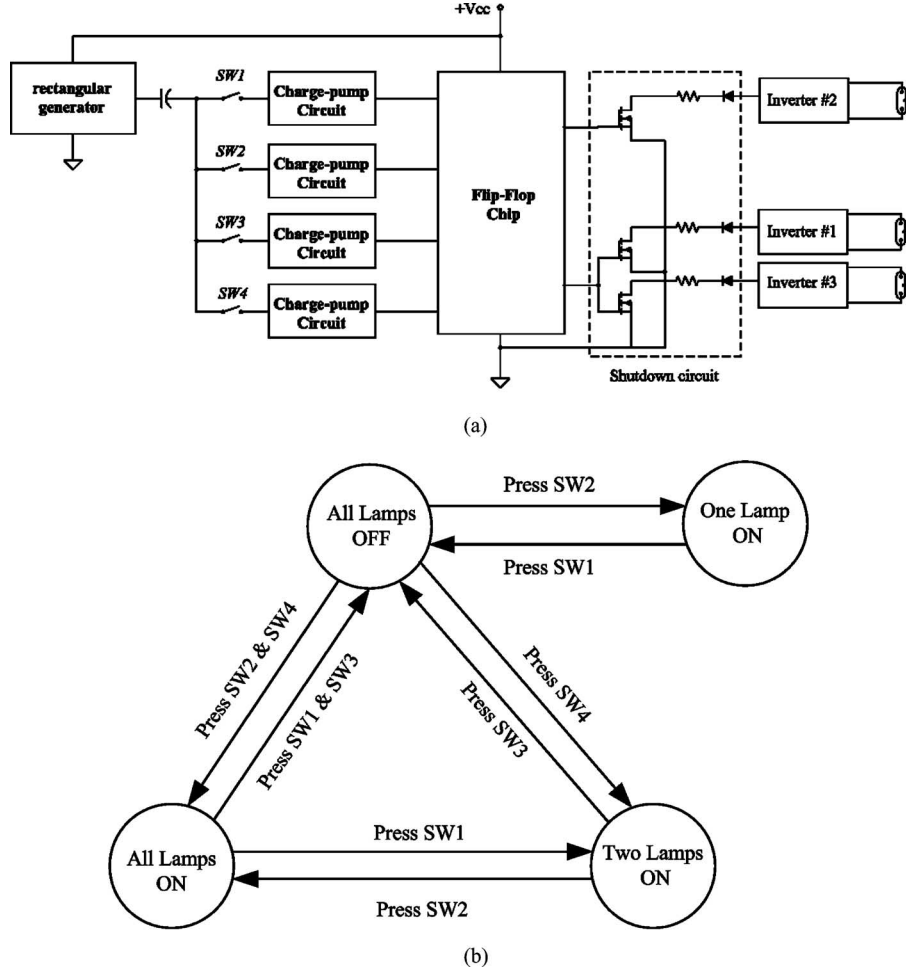

Fig. 3. (a) Block diagram of the dimming control circuit. (b) State machine of dimming control unit.

two lamps and SW4 will turn on the outer two lamps at the same time. Fig. 3(b) shows the state machine of this control unit.

The timing diagram of the proposed controller is shown in Fig. 4.

III. CHARGE PUMP CIRCUIT

A charge pump circuit is designed to guarantee the isolation of the system, so that the user can operate the low-voltage wall switch safely. Instead of inductors, two capacitors are used to realize the isolation. This makes the discrete dimming control circuit more cost-efficient.

The topology of the charge pump circuit is shown in Fig. 5. The output voltage V_0 will be used to set or reset the flip-flop chip and drive the MOSFET.

Laplace transform is applied to analyze the transient response of this circuit. When switch SW is ON, the pulse voltage source will charge the capacitors, and the equivalent circuit is shown in Fig. 6. A small resistor R_1 is added to model the resistance of the diode and the voltage source, and $C_0 = C_1 + C_2$.

Because the voltage source is a pulse voltage source, the circuit has two operating modes.

A. Mode I: The Pulse Voltage Source at Low Level

D_1 is OFF and D_2 conducts. The equivalent circuit is shown in Fig. 7.

By using the KCL, the following equation is obtained and given by

$$C_3 \frac{dv_{o1}}{dt} = \frac{v_{o1}}{R_2}.$$

For initial condition, when $t = 0$, $v_{o1}(0_-) = v_{o1}(0_+) = v_{o2}$.

The following solution is obtained and given by

$$v_{o1} = v_{o2} e^{-(t/R_2 C_3)}. \quad (1)$$

B. Mode II: The Pulse Voltage Source at High Level

Diode D_1 conducts and D_2 is OFF. The equivalent circuit is shown in Fig. 8.

At the transition from mode I to mode II, C_0 is charged to a potential V_{c0} and C_3 is charged to the potential V_{c3} , where

$$V_{c0}(0) = V_{g1}(s) \quad V_{c3}(0) = V_{o1}(s).$$

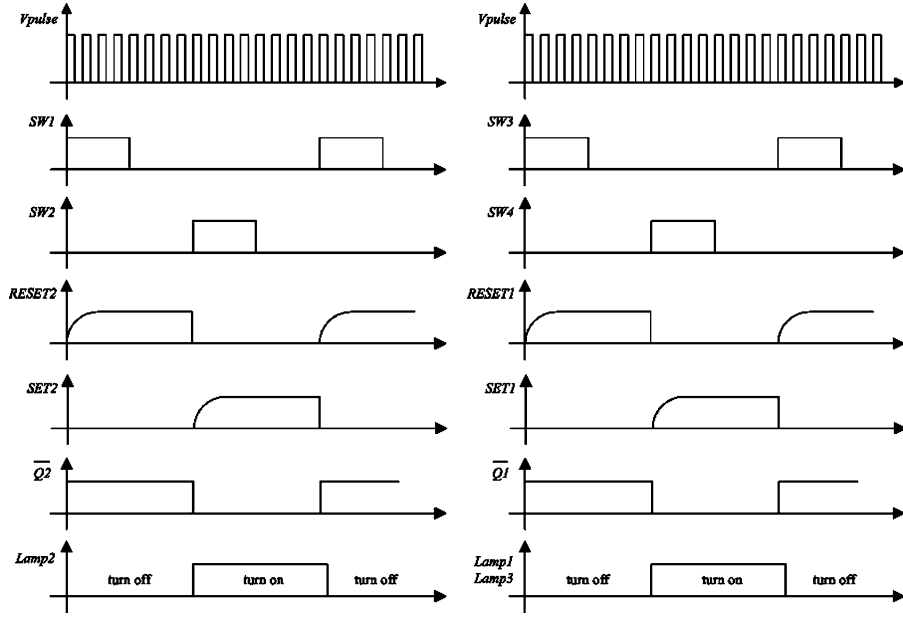

Fig. 4. Timing diagram of proposed digital dimming controller.

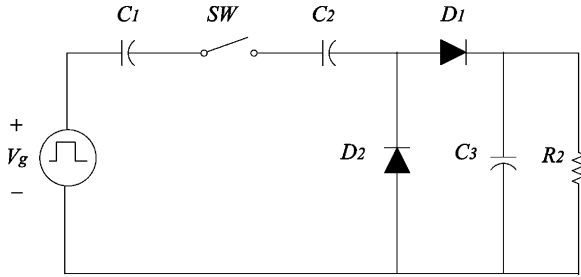

Fig. 5. Topology of the charge pump circuit.

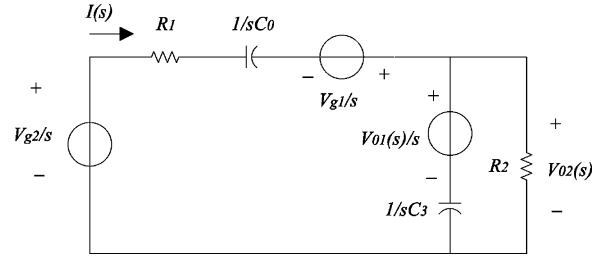

Fig. 8. Laplace transformed equivalent circuit in mode II.

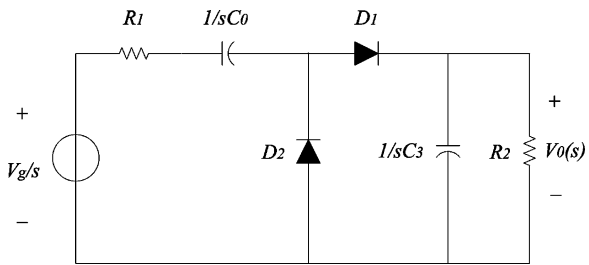

Fig. 6. Charge pump Laplace transformed equivalent circuit.

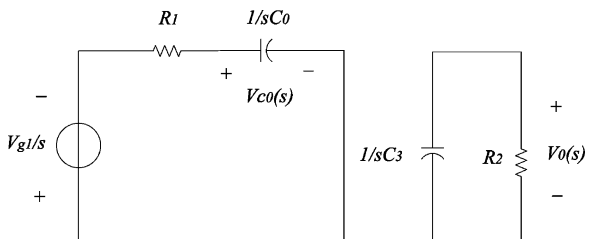

Fig. 7. Laplace transformed equivalent circuit in mode I.

By KCL, we have

$$I(s) = \frac{V_{o2}(s)}{R_2} + \frac{V_{o2}(s) - (V_{o1}(s)/s)}{1/sC_3}. \quad (2)$$

By KVL,

$$\frac{V_{g2}(s)}{s} - \left(R_1 + \frac{1}{sC_0} \right) I(s) + \frac{V_{c0}}{s} - V_{o2}(s) = 0. \quad (3)$$

Upon substitution,

$$\begin{aligned} & \frac{V_{g2}(s)}{s} - \left(R_1 + \frac{1}{sC_0} \right) \left[\frac{V_{o2}(s)}{R_2} + \frac{V_{o2}(s) - (V_{o1}(s)/s)}{1/sC_3} \right] \\ & + \frac{V_{g1}(s)}{s} - V_{o2}(s) = 0 \\ & V_{o2}(s) \\ & = \frac{C_1 R_2 (V_{g1}(s) + V_{g2}(s)) + (sC_1 C_2 R_1 R_2 + C_2 R_2) V_{o1}(s)}{s^2 C_1 C_2 R_1 R_2 + sC_1 R_1 + sC_1 R_2 + sC_2 R_2}. \end{aligned} \quad (4)$$

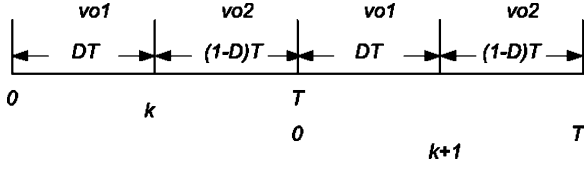

Fig. 9. Time sequence diagram of the charge pump output voltage.

By assuming that R_1 approaches zero,

$$\lim_{R_1 \rightarrow 0} V_{o2}(s) = \lim_{R_1 \rightarrow 0} \frac{C_1 R_2 (V_{g1}(s) + V_{g2}(s)) + (s C_1 C_2 R_1 R_2 + C_2 R_2) V_{o1}(s)}{s^2 C_1 C_2 R_1 R_2 + s C_1 R_1 + s C_1 R_2 + s C_2 R_2}.$$

The following equation is obtained and given by

$$V_{o2}(s) = \frac{V_{o1}(s) C_3 + (V_{g1}(s) + V_{g2}(s)) C_0}{1 + s R_2 (C_0 + C_3)} R_2. \quad (5)$$

Since $V_g(s) = V_{g1}(s) + V_{g2}(s)$, the previous equation can be written as

$$V_{o2}(s) = \frac{(V_{o1}(s) C_3 + V_g C_0) R_2}{1 + s R_2 (C_0 + C_3)}. \quad (6)$$

By using inverse Laplace transform, the following equation is obtained:

$$v_{o2}(t) = \left(\frac{v_{o1} C_3 + v_g C_0}{C_0 + C_3} \right) e^{-(t/R_2(C_0+C_3))} \quad (7)$$

where v_g is a high-frequency rectangular voltage source, with duty cycle T and duty ratio is D . Let k be the k th cycle. The time interval within the cycle is $0 \leq t \leq T$, and the same time interval applies to the next cycle $k + 1$.

This definition is also shown in Fig. 9.

From (1), the voltage at the end of cycle k is related to the voltage at the beginning of the next cycle and is given by the following equation:

$$v_{o1}(0, k+1) = v_{o2}(T, k) e^{-(T/R_2 C_3)}. \quad (8)$$

From (7),

$$v_{o2}(T, k) = \left(\frac{v_{o1}(DT, k) C_3 + v_g C_0}{C_0 + C_3} \right) e^{-[T(1-D)/(R_2(C_0+C_3))]}.$$

Then,

$$\begin{aligned} v_{o1}(DT, k+1) &= v_{o2}(T, k) e^{-(DT/R_2 C_3)} \\ &= \left(\frac{v_{o1}(DT, k) C_3 + v_g C_0}{C_0 + C_3} \right) \\ &\quad \times e^{-[T(1-D)/(R_2(C_0+C_3))]} e^{-(DT/R_2 C_3)}. \end{aligned} \quad (10)$$

Assuming the voltage is constant in each cycle, then $v_{o1}(DT, k)$ can be expressed as $v_{o1}(k)$. Let $\tau_1 = R_2 C_3$ and $\tau_2 = R_2 (C_0 + C_3)$, (10) can be written as

$$v_{o1}(k+1) = \left(v_{o1}(k) \frac{C_3}{C_0 + C_3} + v_g \frac{C_0}{C_0 + C_3} \right) \times e^{-T((D/\tau_1) + ((1-D)/\tau_2))}. \quad (11)$$

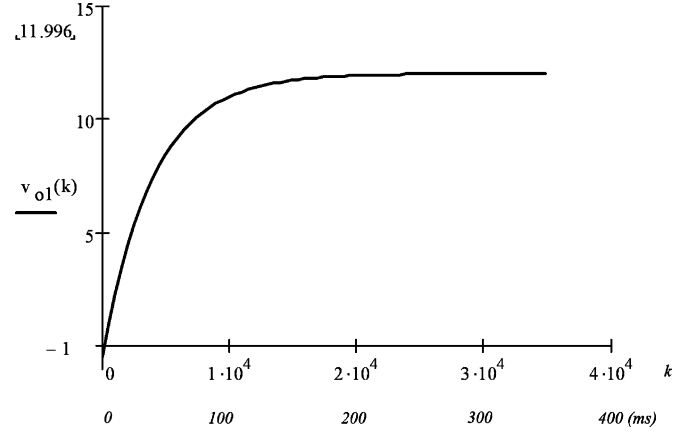

Fig. 10. Charge pump output voltage waveform (MathCAD result).

Let $v_{o1} = v_{oc} + v_{op}$, where v_{oc} is the homogeneous solution and v_{op} is the particular solution

$$v_{op} = \xi \left(\frac{C_3}{C_0 + C_3} \right)^k e^{-kT((D/\tau_1) + ((1-D)/\tau_2))} \quad (12)$$

where ξ is a constant of proportionality

$$v_{oc} = \left(v_{oc} \frac{C_3}{C_0 + C_3} + v_g \frac{C_0}{C_0 + C_3} \right) e^{-T((D/\tau_1) + ((1-D)/\tau_2))}. \quad (13)$$

By solving (13),

$$v_{oc} = v_g C_0 \frac{e^{-T((D/\tau_1) + ((1-D)/\tau_2))}}{(C_0 + C_3 - C_3 e^{-T((D/\tau_1) + ((1-D)/\tau_2))})}. \quad (14)$$

When $k = 1$, $v_{o1}(t) = v_{o1}(DT)$ (initial condition). ξ can be obtained by using (11), (12), and (14)

$$\begin{aligned} \xi &= v_{o1}(DT) \frac{(C_0 + C_3)}{C_3} e^{-T((D/\tau_1) + ((1-D)/\tau_2))} \\ &\quad - v_g \frac{C_0 (C_0 + C_3)}{C_3 (C_0 + C_3 - C_3 e^{-T((D/\tau_1) + ((1-D)/\tau_2))})}. \end{aligned}$$

Finally, the output voltage of the charge pump circuit is given by

$$\begin{aligned} v_{o1}(k) &= \left(\frac{C_3}{C_0 + C_3} \right)^{k-1} \\ &\quad \times \left[v_{o1}(DT) e^{-(k-1)T((D/\tau_1) + ((1-D)/\tau_2))} \right. \\ &\quad \left. - v_g C_0 \frac{e^{-kT((D/\tau_1) + ((1-D)/\tau_2))}}{(C_0 + C_3 - C_3 e^{-T((D/\tau_1) + ((1-D)/\tau_2))})} \right] \\ &\quad + v_g C_0 \frac{e^{-T((D/\tau_1) + ((1-D)/\tau_2))}}{(C_0 + C_3 - C_3 e^{-T((D/\tau_1) + ((1-D)/\tau_2))})}. \end{aligned} \quad (15)$$

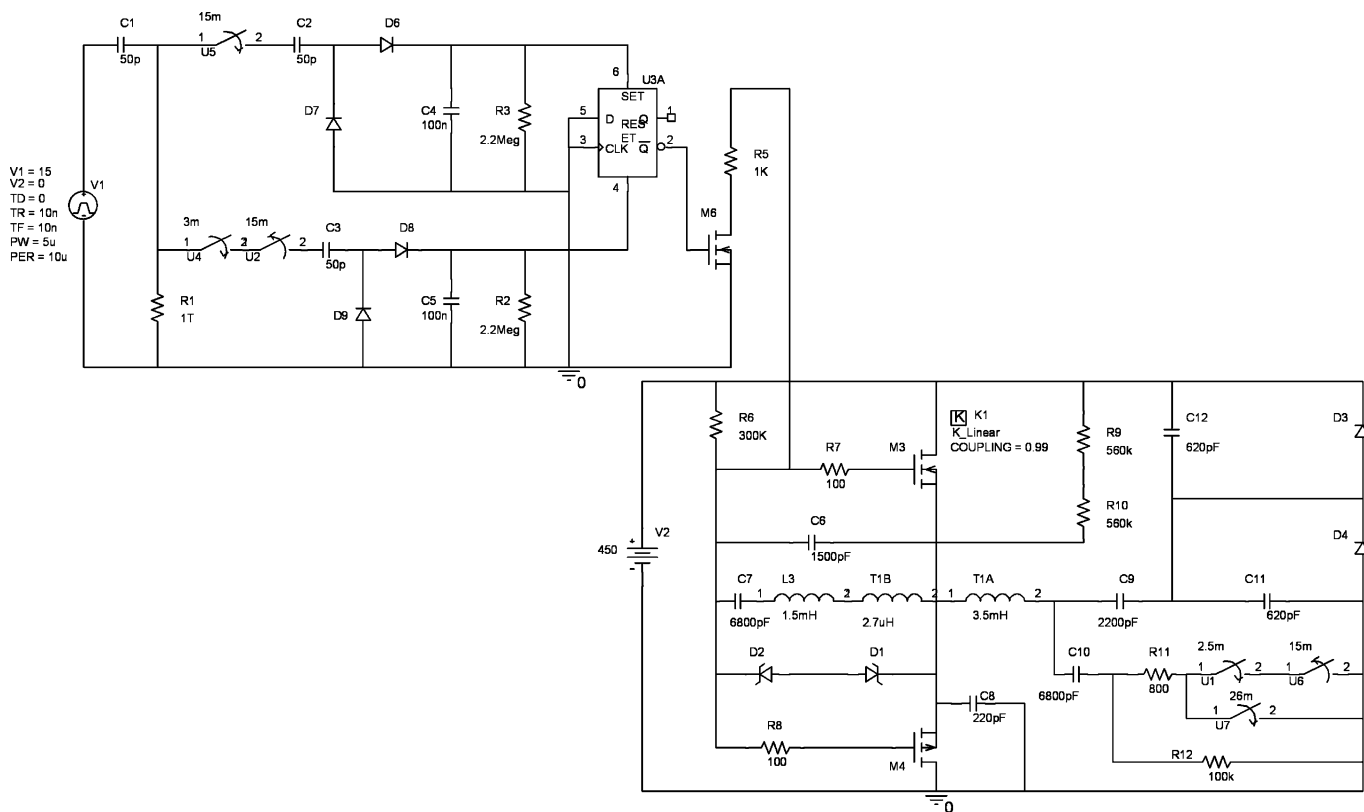

Fig. 11. PSPICE model of the proposed discrete dimming ballast.

According to the previous equation, a MathCAD program has been used to plot the output waveform, which is shown in Fig. 10, with the following parameters:

$$R_1 = 2.4 \text{ M}\Omega$$

$$C_0 = 50 \text{ pF}$$

$$C_3 = 0.1 \text{ }\mu\text{F}.$$

Voltage source V_g is equal to 15 V with the duty cycle $T = 10 \text{ }\mu\text{s}$ and duty ratio $D = 0.5$. The output voltage is about 11.996 V in the steady state and the settling time is about 200 ms.

IV. SIMULATION RESULTS

The PSPICE model of the proposed discrete dimming ballast is shown in Fig. 11. It consists of two sections. One is the discrete dimming controller unit and another is the half-bridge inverter stage of the linear ballast module. Only one lamp is employed in the simulation to show the implementation of the ON and OFF operations. The three lamps system will be presented later. In PSPICE simulation, the lamp is modeled as a pure resistor. During the preheating and ignition, it appears as a large resistor of about 100 K Ω . In the steady state, the resistance of the fluorescent lamp is around 800 Ω .

In the PSPICE model, the lamp is started. The ignition time is about 2.5 ms. After 0.5 ms, the switch U4 is closed. The turn-OFF signal is generated to set the common node at low potential. After 11.5 ms, the lamp is turned off. At 15 ms, the switch U5

is closed. The turn-OFF signal is replaced by the turn-ON signal and the lamp is restarted again at 23 ms.

Fig. 12(a) shows simulation result of the lamp voltage. It matches the design very well. First, the lamp is ignited with a high voltage, and then, it works in the steady state. At about 14.5 ms, it turns off completely, so the voltage is zero. At 23 ms, the lamp is restarted. Lamp voltage and current in the steady state are shown in Fig. 12(b).

V. EXPERIMENTAL RESULTS

Discrete dimming control circuit has been built in the General Electric (GE) laboratory and used with the GE UltraMAX-F32T8 nondimming linear universal ballast module. Its schematic has been shown in Fig. 13(a). A schematic diagram of one inverter stage with dimming control is shown in Fig. 13(b). Power supply is 120 V, 50 Hz. Three 32-W T8 lamps are controlled to obtain three discrete lighting levels.

The proposed discrete dimming ballast has been tested in the laboratory and compared with the simulation results.

When OFF switch SW1 is pressed by hand, the charge pump circuit resets the flip-flop and makes it provide a high level to the shutdown circuit. Then, the inverter #2 is shutdown and the center lamp #2 is turned off.

Fig. 14(a) shows the lamp voltage, control signal, and charge pump output. Ch1 shows the voltage waveform of lamp #2, Ch2 shows the digital output signal of discrete dimming controller, and Ch4 shows the output voltage of the charge pump circuit. As

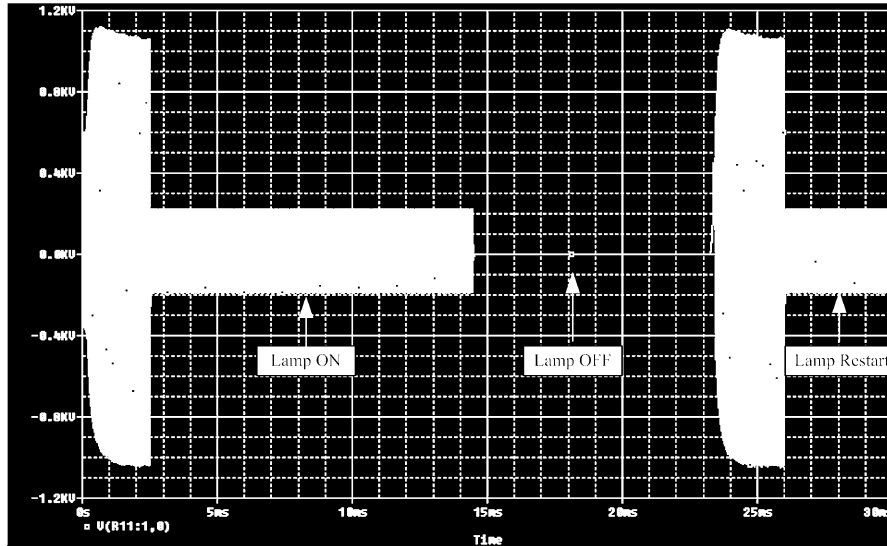

(a)

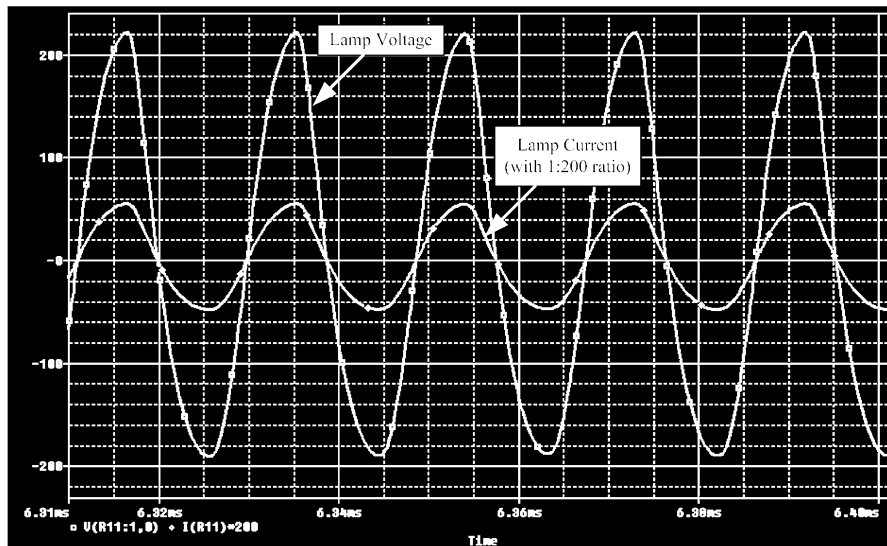

(b)

Fig. 12. (a) Simulated lamp voltage under discrete dimming control. (b) Simulated lamp voltage and current in the steady state.

it has been shown, when the output voltage of the charge pump circuit increases from zero to a certain value, it will trigger the flip-flop chip to generate a high-level signal, 15 V. This digital signal turns on the transistor of the shutdown circuit to shut down the inverter, and then, the lamp gets turned off.

When ON switch SW2 is pressed, the charge pump circuit sets the flip-flop and makes it provide a low level to the shutdown circuit to turn on inverter #2. The center lamp #2 is turned on again.

Fig. 14(b) also shows the center lamp #2 voltage, the output signal of the discrete dimming controller, and output signal of the charge pump circuit. The output voltage that is generated by the charge pump circuit triggers the flip-flop chip to generate a low-level signal. The signal turns off the transistor of the shutdown circuit to operate the inverter and turn on the lamp.

During the same operation, the OFF switch SW3 turns off the lamp. The difference is that the output of the flip-flop controls inverter #1 and inverter #3 together. So, lamp #1 and lamp #3 are turned off at the same time. Fig. 15(a) shows the lamp #1 voltage, the lamp #3 voltage, and the output voltage of the charge pump circuit.

Switch SW4 turns on the lamp #1 and lamp #3 simultaneously. Fig. 15(b) shows the lamp #1 voltage, the lamp #3 voltage, and the output voltage of the charge pump circuit IV.

Lamp voltage and current are shown in Fig. 16. It can be seen that the experimental result matches with the simulation result in Fig. 12(b) well. There are small differences in the amplitude values of the lamp voltage and current, which is due to the fact that the lamp simulation model has modeling error with the real lamp.

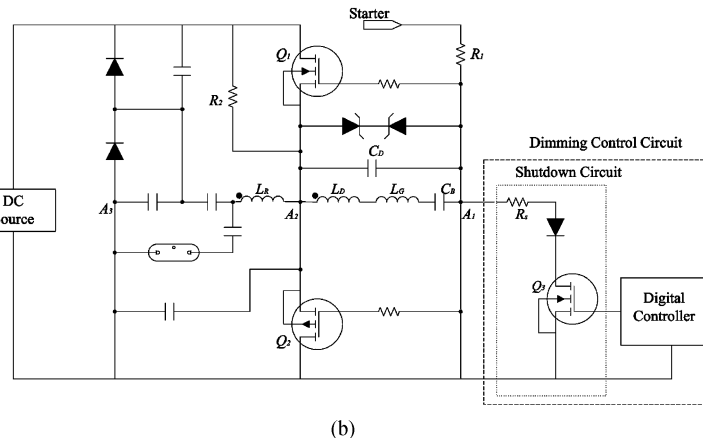
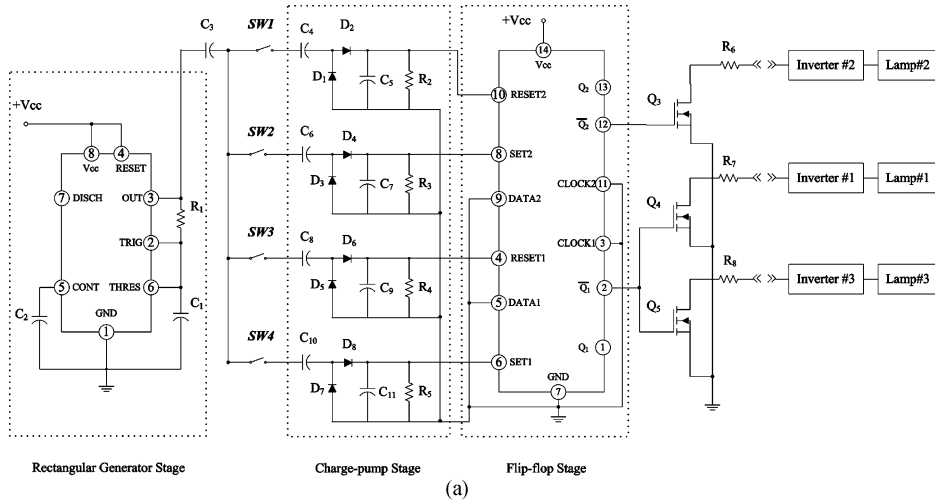

Fig. 13. (a) Proposed schematic of a digital dimming controller. (b) Schematic diagram of one inverter stage with a proposed dimming controller.

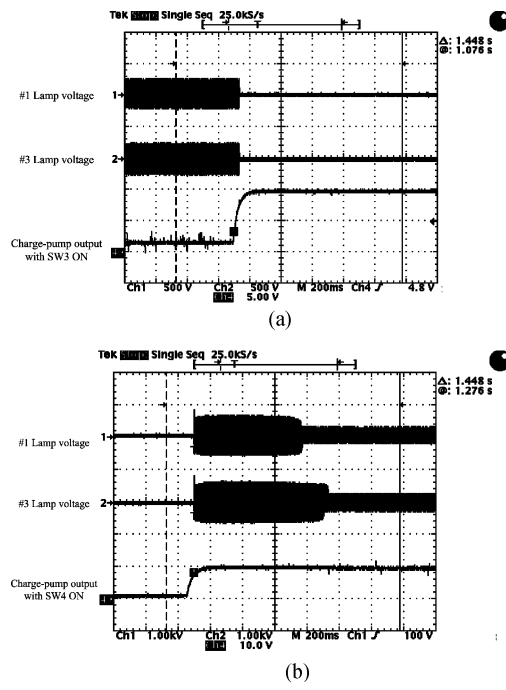
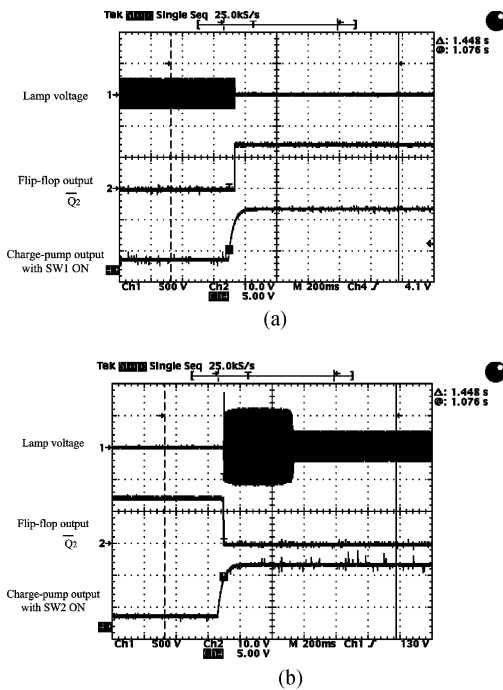

Fig. 14. (a) Lamp #2 voltage with OFF signal. (b) Lamp #2 voltage with ON signal.

Fig. 15. (a) Lamp #1, #3 voltages with OFF signal. (b) Lamp #1, #3 voltages with ON signal.

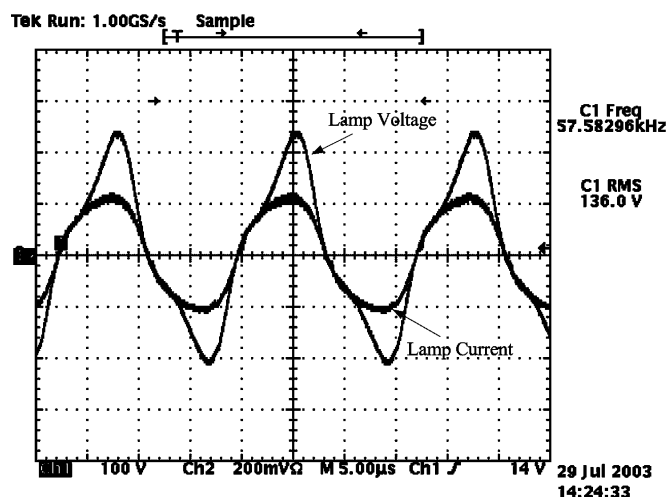

Fig. 16. Lamp voltage and current of the discrete dimming ballast (experimental results).

VI. CONCLUSION

This paper has presented the analysis and design of the novel discrete dimming control ballast for linear fluorescent lamps. Three discrete lighting levels, full light, 66% light, and 33% light, are obtained by using the proposed dimming ballast to control three fluorescent lamps. The proposed discrete dimming control circuit is built in the electronic ballast module and provides digital signals to realize the ON-OFF operation of the inverters. Compared with the conventional step dimming or ON-OFF control methods, the proposed discrete dimming control circuit is built in the ballast module to control the ON-OFF operation of the inverters digitally. The dimming control circuit communicates with the wall switches directly without the need to use relays. Although two more wall switches are needed, compared with the relays, the cost of the proposed dimming control circuit is much lower. The dimming control circuit also provides a very good isolation. The proposed discrete dimming ballast is installed by keeping the original wiring system. No new power wires are required; thus, the installment cost is lower.

The proposed discrete dimming ballast has been built and tested in the laboratory. The experimental results are in excellent agreement with the results obtained from the mathematic model and PSPICE simulation.

Now we have developed new ballast with series or parallel lamp operation, which enable one inverter to control multiple lamps. By combining this technology and the proposed strategy in this paper, we believe that two lamps can be controlled by the same inverter, instead of one inverter for each lamp. Since one inverter can control multiple lamps, it is possible to control of a higher number of lamps than three. Further research will be done for this.

REFERENCES

- [1] C. S. Moo, H. L. Cheng, H. N. Chen, and H. C. Yen, "Designing dimmable electronic ballast with frequency control," in *Proc. IEEE Appl. Power Electron. Conf.*, Mar. 1999, vol. 2, pp. 727–733.
- [2] S. Y. R. Hui, Y. K. E. Ho, and H. Chung, "An electronic ballast with dimming range, high PF, and low EMI," *IEEE Trans. Power Electron.*, vol. 16, no. 4, pp. 465–472, Jul. 2001.

- [3] W. H. Ki, J. Y. Shi, E. Yau, P. K. T. Mok, and J. K. O. Sin, "Phase-controlled dimmable electronic ballast for fluorescent lamps," in *Proc. IEEE Power Electron. Spec. Conf.*, 1999, vol. 2, pp. 1121–1125.
- [4] F. J. Azcondo, S. Bracho, and C. Branas, "Pulsewidth modulation control of electronic ballast for dimming control of fluorescent lamps," in *Proc. IEEE Int. Symp. Ind. Electron.*, Jul. 1997, vol. 2, pp. 537–542.
- [5] C. Contenti, "Digitally addressable DALI dimming ballast," in *Proc. IEEE Appl. Power Electron. Conf.*, 2002, vol. 2, pp. 936–942.
- [6] A. V. Stankovic, D. Uppala, D. Kachmarik, M. C. Cosby, Jr., and L. Nerone, "Design, analysis and optimization of a universal power factor correction circuit for linear fluorescent lamps," in *Proc. Illuminating Eng. Soc. North Amer. Conf.*, Aug. 2003, pp. 73–101.
- [7] L. R. Nerone, D. J. Kachmarik, and M. M. Secen, "Lamp ballast with triggerless starting circuit," U.S. Patent 5 917 289, Jun. 29, 1999.
- [8] B. Trevino, M. C. Cosby, G. Grigor, and L. R. Nerone, "Shutdown circuit for a half-bridge converter," U.S. Patent 6 421 260, Jul. 16, 2002.
- [9] S. T. S. Lee, H. S.-H. Chung, and S. Y. Hui, "A novel electrode power profiler for dimmable ballasts using DC link voltage and switching frequency controls," *IEEE Trans. Power Electron.*, vol. 19, no. 3, pp. 847–853, May 2004.
- [10] S. T. S. Lee, H. S. H. Chung, and S. Y. R. Hui, "An electrode power control scheme for dimmable electronic ballasts," *IEEE Trans. Ind. Electron.*, vol. 50, no. 6, pp. 1335–1337, Dec. 2003.
- [11] M. S. Perdigao, J. M. Alonso, M. A. D. Costa, and E. S. Saraiva, "Comparative analysis and experiments of resonant tanks for magnetically controlled electronic ballasts," *IEEE Trans. Ind. Electron.*, vol. 55, no. 9, pp. 3201–3211, Sep. 2008.