

Cleveland State University
EngagedScholarship@CSU



Chemical & Biomedical Engineering Faculty
Publications

Chemical & Biomedical Engineering Department

5-1999

Reversal Flow in Fixed-Bed Reactors Operating Under Reaction-Regeneration Cycles

Daniel O. Borio

Planta Piloto de Ingenieria Quimica

Noemi S. Schbib

Planta Piloto de Ingenieria Quimica

Jorge E. Gatica

Cleveland State University, j.gatica@csuohio.edu

Follow this and additional works at: https://engagedscholarship.csuohio.edu/encbe_facpub

 Part of the [Catalysis and Reaction Engineering Commons](#)

How does access to this work benefit you? Let us know!

Publisher's Statement

NOTICE: this is the author's version of a work that was accepted for publication in Chemical Engineering Science. Changes resulting from the publishing process, such as peer review, editing, corrections, structural formatting, and other quality control mechanisms may not be reflected in this document. Changes may have been made to this work since it was submitted for publication. A definitive version was subsequently published in Chemical Engineering Science, [54, 10, (May 1999)] DOI 10.1016/S0009-2509(99)00064-0

Original Citation

Borio, D., Schbib, N., , & Gatica, J. (1999). Reversal flow in fixed-bed reactors operating under reaction-regeneration cycles. Chemical Engineering Science, 54(10), 1313-1318. doi:10.1016/S0009-2509(99)00064-0

Repository Citation

Borio, Daniel O.; Schbib, Noemi S.; and Gatica, Jorge E., "Reversal Flow in Fixed-Bed Reactors Operating Under Reaction-Regeneration Cycles" (1999). *Chemical & Biomedical Engineering Faculty Publications*. 52.

https://engagedscholarship.csuohio.edu/encbe_facpub/52

This Article is brought to you for free and open access by the Chemical & Biomedical Engineering Department at EngagedScholarship@CSU. It has been accepted for inclusion in Chemical & Biomedical Engineering Faculty Publications by an authorized administrator of EngagedScholarship@CSU. For more information, please contact library.es@csuohio.edu.

Reversal flow in fixed-bed reactors operating under reaction-regeneration cycles

Daniel O. Borio (*), Noemí S. Schbib (*) and Jorge E. Gatica (**)

(*) Planta Piloto de Ingeniería Química (UNS-CONICET). Camino La Carrindanga, Km 7. Casilla de Correo 717. 8000 Bahía Blanca. ARGENTINA

(**) Dept. of Chemical Engng., Cleveland State University, 1960 East 24th Street, 459 Stilwell Hall, Cleveland, OH 44115-2425, USA.

Abstract - The unsteady state simulation of a set of industrial fixed-bed reactors is presented. The catalytic dehydrogenation of 1-butene into 1,3-butadiene is selected as case study. These reactors operate under reaction-regeneration cycles. Each stage of the process, i.e., dehydrogenation (deactivation by coking), steam purge, oxidative regeneration and evacuation, is simulated by means of the corresponding dynamic model. The kinetic parameters used in the dehydrogenation and regeneration stages for a $\text{Cr}_2\text{O}_3/\text{Al}_2\text{O}_3$ catalyst are taken from the literature. The performance of the reactors is investigated for two different operation modes: conventional (CO) and periodic flow reversal (PRFO). The PRFO mode shows significantly lower values for the average bed temperature and residual coke concentrations than those corresponding to the CO mode. This behaviour has a favourable effect on the production rate of butadiene. In addition, the influence of the catalyst sintering is analysed in this paper for both operation modes. The deactivation rate by thermal degradation is lower in the case of PRFO due to the lower average temperature of the catalyst bed. Periodic flow reversal strategies provide an economical and efficient alternative to optimise cyclic processes.

Keywords: reversal flow, reaction-regeneration cycles, deactivation, coking, catalyst sintering

INTRODUCTION

The operation of adiabatic fixed-bed reactors with periodic flow reversal was proposed by Borekov et al. (1979). Borekov and co-workers proposed this mode of operation for several processes such as ammonia and methanol synthesis, oxidation of SO_2 and gas effluent purification (Matros, 1989). The reversal flow approach has shown to be particularly appropriate for mildly exothermic reactions in autothermal reactors (Nieken et al., 1995). In the present paper, a periodic reversal flow approach is applied to an industrial process: the catalytic dehydrogenation of 1-butene into 1,3-butadiene. This process is commonly carried out under adiabatic conditions and at high temperatures and low reactants partial pressures. The operation is cyclic, with the feed being periodically switched between beds. After 6 to 8 minutes of operation of the first reactor, the feed is switched to a second catalyst bed. The first bed is then purged with steam, and the coke deposited on the catalyst is burned off by combustion in air or mixtures with low oxygen concentration. When the regeneration has been completed, the air stream is shut off and a fuel gas mixture is admitted to burn off the residual oxygen and pre-treat the catalyst under

reducing conditions (Rielly, 1977; Craig and Dufallo, 1979). It can be shown that, for continuous operation, at least three beds in parallel must be used (Figure 1).

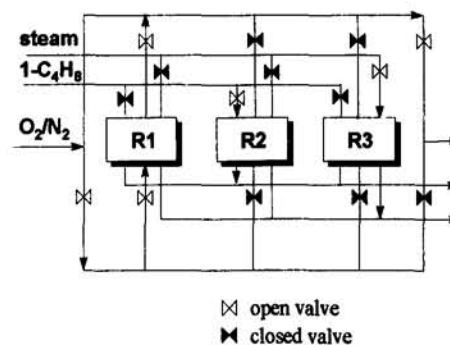

Figure 1: Schematic of the process with "R1" operating under reversal flow conditions during the regeneration stage.

The combustion heat released during the regeneration stage will be stored in the solid phase (catalyst and inert diluent). This energy can be then used in the

production stage to carry out the endothermic reaction and to preheat the reactants. Thus, the catalyst beds act simultaneously as chemical reactors and as regenerative heat exchangers. This kind of multifunctional reactor (Westertep, 1992) has been used in industry during decades. The dynamic simulation of the four stages of the process: reaction, purge, regeneration and evacuation is presented next. The performance of the bed arrangement under periodic reversal flow is analysed and compared with that of the conventional operation.

MATHEMATICAL MODEL

Unsteady state, plug flow and adiabatic operation conditions are considered for the four stages. Details on the dynamic model can be found elsewhere (Borio et al., 1992; Borio and Schbib, 1995). The dehydrogenation stage (DS) is simulated using the kinetic data reported by Dumez and Froment (1976). Due to the short period of the intermediate stages, purge (PS) and evacuation (ES), only a heat transfer process between gas and solid is considered (i.e., changes in catalyst activity by decoking are neglected). During the regeneration stage a sharp interface model with external mass and heat transfer resistance is chosen for the catalyst particle. The kinetic parameters for the coke combustion over a $\text{Cr}_2\text{O}_3/\text{Al}_2\text{O}_3$ catalyst were selected from the literature (Mickley et al., 1965).

The boundary conditions for the coke deposition and solid phase temperature at the beginning of each stage were the corresponding profiles from the previous stage. To simulate reversal flow conditions, these initial axial profiles are reversed at the beginning and the end of the corresponding stage. In order to solve the dynamic models, the axial coordinate is discretized and the time integration is performed by means of the Gear's algorithm (Shampine and Gear, 1979).

During the start-up the system evolves towards a "steady" cycle in which the solid-phase temperature and coke profiles at the end of ES coincide with those of the initial conditions for the DS. The numerical solution is found through an iterative process (Borio and Schbib, 1995).

In practice, besides the deactivation process by coking, the catalyst is also subject to a slower

deactivation process due to thermal degradation. This catalyst deactivation by sintering has also been incorporated into the mathematical model via the kinetic expression reported by Blasco et al. (1992). Due to the irreversible catalyst deactivation, the steady cycle mentioned above is not observed when both coking and sintering are taken into account (Borio et al., 1999).

COMPARISON OF THE REACTOR PERFORMANCE

Periodic Reversal Flow Operation (PRFO) and Conventional Operation (CO) modes are compared for the conditions listed in Table 1. The same maximum allowable temperature ($T_{MA} = 923 \text{ °K}$) is considered for both schemes. The feed temperature during the RS and PS (T_0) was chosen as the iteration variable to reach the desired T_{MA} value. For the CO mode, a single (standard) flow direction is adopted for the four stages. For the PRFO, the flow is reversed every other cycle (i.e., cycle A: standard flow, cycle B: reverse flow) during the regeneration stage (RS) only.

Figures 2 to 4 show the evolution towards the steady cycle for CO and PRFO modes. Catalyst deactivation by sintering is neglected. At the beginning of the start-up process, the catalyst is assumed to be isothermal (823 °K) at coke-free conditions. For both modes of operation, the axial solid temperature and coke concentration averages increase along the first cycles before reaching their final (steady) values (Figures 2 and 3). Once the final steady cycle is reached, the PRFO mode shows significantly lower values for $T_{s,av}$ and $C_{c,av}$ than those corresponding to the conventional operation mode. This behaviour has a favourable effect on the steady production rate of butadiene (cf. Figure 4), resulting in a production increase of approximately 4 % relative to the production rate observed for the conventional operation mode. This improvement can be appreciated more clearly in Figure 5, where the outlet conversion of 1-butene (X_b) vs. time is shown during the DS. Higher conversion levels are observed for the PRFO mode (for both, cycles A and B) for most of the dehydrogenation stage.

Table 1: Operating conditions of the different stages

	DS	PS	RS (CO)	RS (PRFO - Cycle A)	RS (PRFO - Cycle B)	ES
time (min)	5	2	6	6	6	2
flow direction	standard	standard	standard	standard	reverse	standard
T_0 (K)	823	850.6 (CO)/ 757 (PRFO)	850.6	757	757	823
P (atm)	0.25	1	1	1	1	0.25
feed	1-butene	steam	3% O_2 - 97 % N_2	3% O_2 - 97 % N_2	3% O_2 - 97 % N_2	fuel-gas

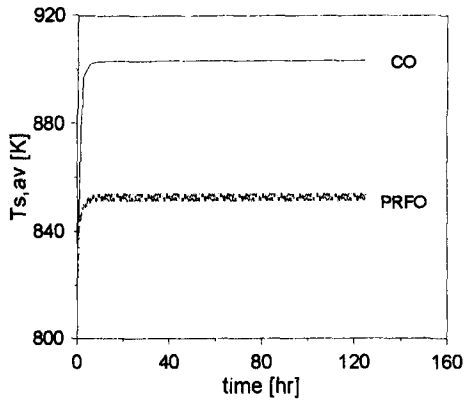

Figure 2: Average bed (solid phase) temperature after regeneration, as affected by the operation time.

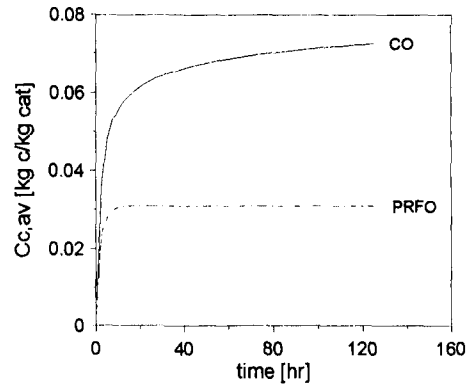

Figure 3: Average bed coke concentration after regeneration, as affected by the operation time.

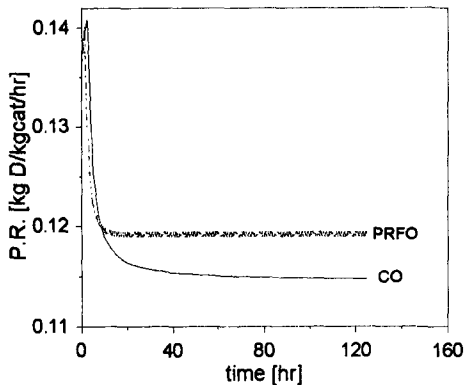

Figure 4: Production rate of butadiene as affected by the operation time.

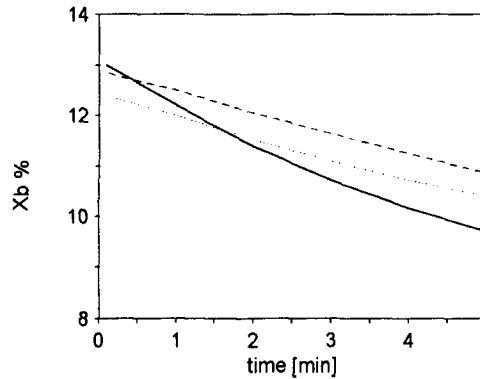

Figure 5: 1-butene conversion during the DS.
 — : CO;
 - - - : PRFO, cycle A; : PRFO, cycle B.

Figures 6 and 7 show the “steady-state” (once the steady cycle has been reached) axial coke and solid-phase temperature profiles at the end of the regeneration stage for both flow configurations. Despite resulting in a relatively flat temperature profile, the CO mode exhibits markedly non-uniform coke concentration profiles. This accumulation of coke at the reactor outlet is a consequence of the total consumption of oxygen in the first half of the bed (Borio and Schib, 1995). In fact, for standard flow conditions the regeneration rate near the reactor

outlet is very low and therefore the coke profiles before and after regeneration are almost coincident (see Figure 6, curves corresponding to CO). When the PRFO mode is followed, the residual coke (after regeneration) is distributed more uniformly (Figure 6). This result can be better interpreted by examining Figures 8 and 9. As it can be seen in Figure 8, the oxygen burns the coke alternatively at the inlet and outlet zones (cycles A and B, respectively). The corresponding coke profiles at the end of DS and RS stages are shown in Figure 9.

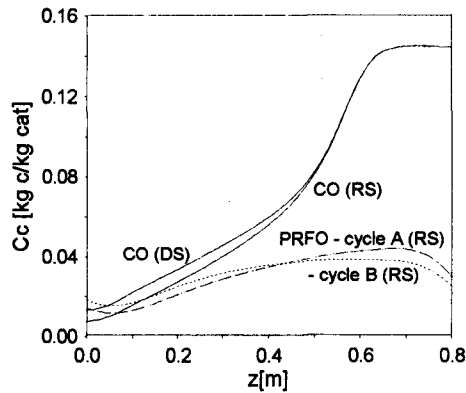

Figure 6: Coke profiles at the end of RS for CO and PRFO, and at the end of DS for CO.

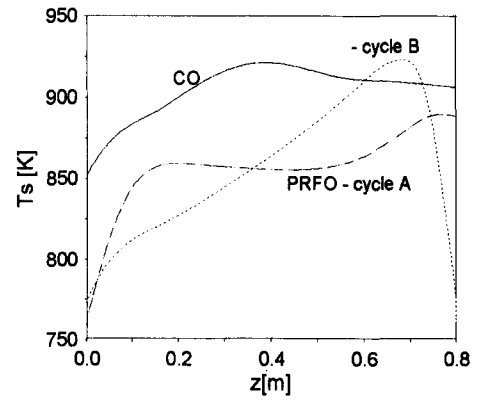

Figure 7: Temperature profiles (solid phase) after regeneration.

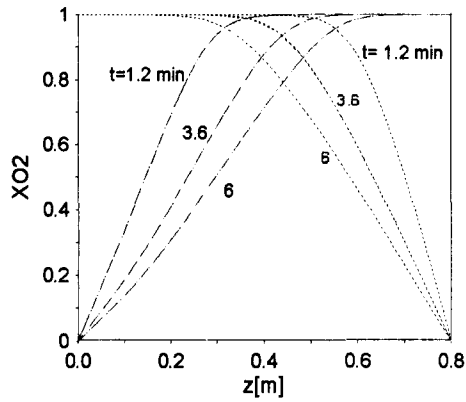

Figure 8: Oxygen conversion profiles at different times during the RS (PRFO).

—•—: PRFO, cycle A; ---- PRFO, cycle B

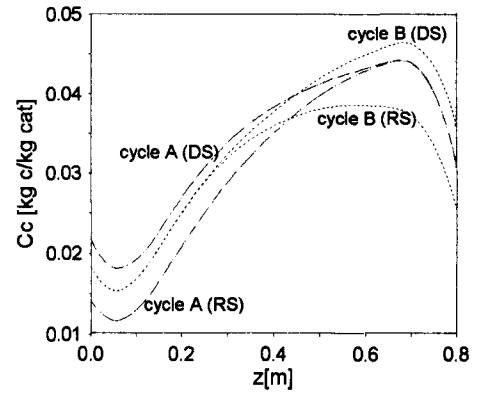

Figure 9: PRFO: Coke profiles at the end of DS and RS, for cycles A and B.

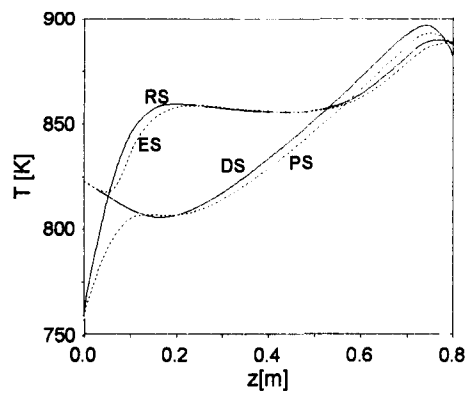

Figure 10: Axial temperature profiles at the end of the four stages (PRFO, cycle A).

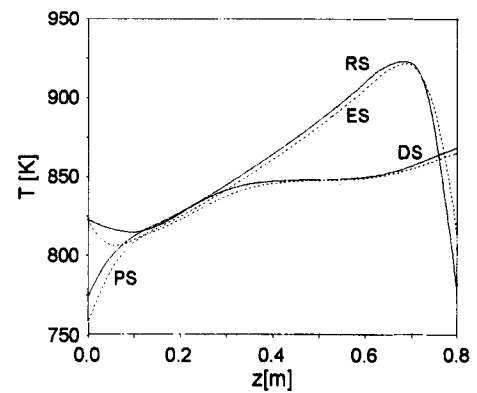

Figure 11: Axial temperature profiles at the end of the four stages (PRFO, cycle B).

Figures 10 and 11 show the temperature profiles corresponding to the PRFO mode at the end of DS, PS, RS and ES for cycle A and B respectively. As it can be seen, the maximum temperature ($T_{MA} = 923$ °K) is reached at the end of RS in cycle B (reversal flow conditions). According to the results shown in Figure 8 and 9, the highest temperature rises during the RS (from the PS to the RS curves) are located near the reactor inlet for cycle A, and near the reactor outlet ($z=0.8$ m) for cycle B. Each stage begins with a markedly non-uniform temperature profile due to the strong heat effects involved in the DS and RS, the short duration of the intermediate stages and the periodic reversal flow conditions.

The above comparison between the reactor performance was also carried out using other alternatives of reversal flow operation (e.g., reversed flow during RS in all cycles, reversed flow during DS and RS in alternate cycles, etc.). The alternative presented in this paper (reversed flow during RS in alternate cycles) was selected because it showed the highest value of the butadiene production rate.

Influence of the catalyst sintering

The results shown in Figures 2 to 11 were obtained assuming negligible catalyst deactivation effects due to sintering. Results including catalyst-sintering effects are presented in Figures 12-15. These results were obtained using the catalyst sintering kinetic model as reported by Blasco et al. (1992). The operating conditions were those listed in Table 1.

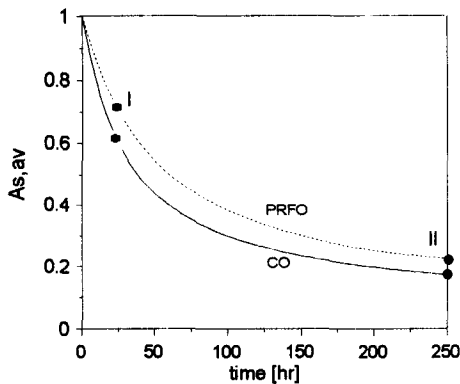

Figure 12: Influence of the catalyst sintering. Average bed catalyst activity after regeneration, as affected by the operation time.

Figure 12 shows the evolution of the average bed catalyst activity (coke-free conditions) for both the CO and PRFO modes. The catalyst deactivation rate by sintering is lower in the case of PRFO due to the lower average temperature of the catalyst bed. These temperature differences can be seen in Figures 13 and 14, where the axial temperature profiles for two different levels of catalyst activity ($A_{S,av}$) are shown. For the conditions of Figure 13 (25 hours of operation, point I of Figure 12), the catalyst is only mildly sintered and therefore the temperature profiles are similar to those observed in the absence of sintering (cf. Figure 7). When the catalyst bed is kept on continuous operation for longer periods (e.g. 250 hours of operation, point II of Figure 12) the temperature decreases and both modes CO and PRFO, exhibit flat temperature profiles due to significant catalyst sintering (see Figure 14). Again, the average bed temperature corresponding to the PRFO mode is lower than that observed for the CO mode. The PRFO mode also shows lower amounts of residual coke (after regeneration) than those observed for the CO mode. This fact can be confirmed by inspection of Figures 13 (cycle 100, 25 hr. in operation) and 14 (cycle 1000, after 250 hr.). Consequently, if the PRFO mode is adopted, the reactor could be operated at a higher catalyst activity (coking and sintering) than in the case of conventional operation mode. This phenomenon has a favourable influence on the cumulative production of butadiene, as it can be seen in Figure 15.

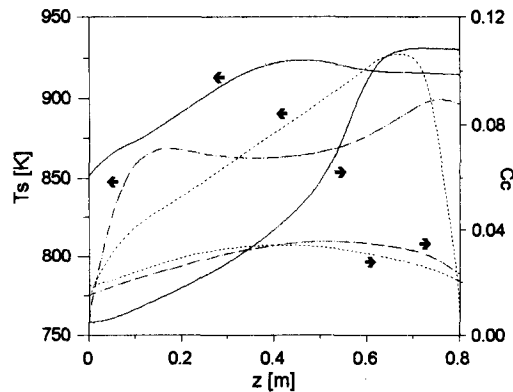

Figure 13: Influence of the catalyst sintering. Axial profiles of temperature (solid phase) and coke concentration, after regeneration, for cycle 100 (operation time = 25 hr.)

—: CO
 - - - : PRFO, cycle A; ····· PRFO, cycle B

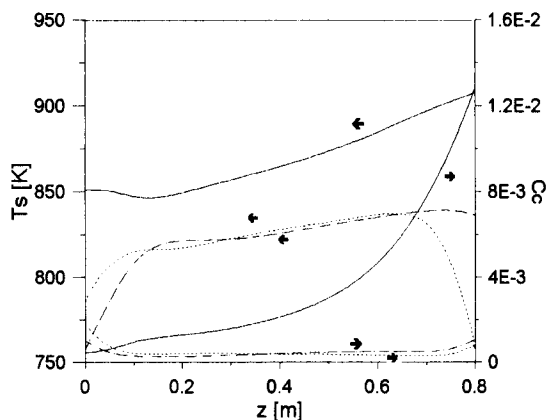

Figure 14: Influence of the catalyst sintering. Axial profiles of temperature (solid phase) and coke concentration, after regeneration, for cycle 1000 (operation time = 250 hr.).

—: CO
 — — —: PRFO, cycle A; - - - -: PRFO, cycle B

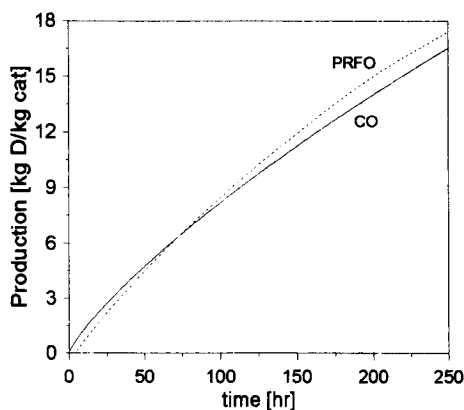

Figure 15: Influence of the catalyst sintering. Cumulative production of butadiene for the PRFO and CO.

CONCLUSIONS

Periodic reversal flow operation constitutes a suitable alternative to influence favourably coke and temperature distributions in the industrial process of 1-butene dehydrogenation. Moreover, an integral use of the catalyst beds can be made, avoiding excessive accumulation of coke at the reactor outlet and yielding increased production rates. As additional advantage, PRFO mode would extend the catalyst life by slowing down catalyst deactivation effects by thermal degradation. Since the cyclic nature of the process requires a periodic adjustment of operating conditions, the implementation of a PRFO approach would not require significant reactor design and operation changes.

NOTATION

As = local activity coefficient at coke-free conditions (sintering)
 C_C = coke concentration, kg. coke/kg. cat.
 CO = Conventional Operation
 D = butadiene
 DS = dehydrogenation stage
 ES = evacuation stage
 P = total pressure, atm
 PS = purge stage
 PRFO = Periodic Reversal Flow Operation
 P.R. = production rate, kg_D / (kg_{cat} hr)
 RS = Regeneration stage
 T = temperature, K
 X_b = butene conversion
 X_{O₂} = oxygen conversion
 z = axial coordinate, m

Subscripts

av = axial average
 C = coke

MA = maximum allowable

s = solid phase

0 = at the reactor inlet

REFERENCES

- Boreskov G. K., Y. S. Matros, O. V. Kiselev, (1979). *Kinet. Catal.*, 20, 773-780.
- Blasco V., C. Royo, A. Monzón, J. Santamaría (1992), *AIChE J.*, 38, 237-243.
- Borio D.O., M. Menéndez, J. Santamaría (1992). *Ind. Eng. Chem. Res.*, 31(12), 2699-2707.
- Borio D. O., N. S. Schbib (1995). *Comp. & Chem. Eng.*, 19S, pp. S345-S350.
- Borio D. O., N. S. Schbib, J. E. Gatica (1999). *Proceedings Int. Symp. on React. Kinet. and Dev. Catal. Proc.*, Brugge (Belgium).
- Craig R. G., J. M. Dufallo (1979). *Chem. Eng. Prog.*, February, 62-65.
- Dumez F. J., G. F. Froment (1976). *Ind. Eng. Chem. Proc. Des. Dev.*, 15, 291-301.
- Matros Y. S., (1989) *Catalytic Processes under Unsteady-State Conditions*, Elsevier, Amsterdam.
- Mickley H. S., J. W. Nestor, L. A. Gould (1965). *The Can. J. Chem. Eng.*, 61-68.
- Nieken, U., G. Kolios, G. Eigenberger (1995), *AIChE J.*, 41(8), 1915-1925.
- Rielly T. (1977). In *Encyclopedia of Chem. Process. and Des.* (McKetta Ed.), V. 5, 110-170, Marcel Dekker.
- Shampine, L.F. and C.W. Gear (1979), *SIAM Review*, 21, 1-17.
- Westerterp, K. R. (1992). *Chem. Eng. Sci.*, 47(9-11), 2195-2206.