

Cleveland State University  
EngagedScholarship@CSU



---

Mechanical Engineering Faculty Publications

Mechanical Engineering Department

---

9-2003

# Vibration Based Crack Detection in a Rotating Disk: Part 1—An Analytical Study

Andrew L. Gyekenyesi

*Ohio Aerospace Institute, [Andrew.L.Gyekenyesi@grc.nasa.gov](mailto:Andrew.L.Gyekenyesi@grc.nasa.gov)*

Jerzy T. Sawicki

*Cleveland State University, [j.sawicki@csuohio.edu](mailto:j.sawicki@csuohio.edu)*

George Y. Baaklini

*NASA Glenn Research Center, [George.Y.Baaklini@grc.nasa.gov](mailto:George.Y.Baaklini@grc.nasa.gov)*

Follow this and additional works at: [https://engagedscholarship.csuohio.edu/enme\\_facpub](https://engagedscholarship.csuohio.edu/enme_facpub)

 Part of the [Mechanical Engineering Commons](#)

**How does access to this work benefit you? Let us know!**

---

## Original Citation

Gyekenyesi, A.L., Sawicki, J.T., Baaklini, G.Y., "Vibration Based Crack Detection in a Rotating Disk: Part I – An Analytical Study," NASA/TM-2003- 212624

This Report is brought to you for free and open access by the Mechanical Engineering Department at EngagedScholarship@CSU. It has been accepted for inclusion in Mechanical Engineering Faculty Publications by an authorized administrator of EngagedScholarship@CSU. For more information, please contact [library.es@csuohio.edu](mailto:library.es@csuohio.edu).

NASA/TM—2003-212624

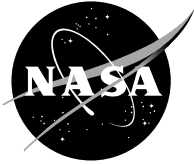

# Vibration Based Crack Detection in a Rotating Disk

Part 1—An Analytical Study

Andrew L. Gyekenyesi  
Ohio Aerospace Institute, Brook Park, Ohio

Jerzy T. Sawicki  
Cleveland State University, Cleveland, Ohio

George Y. Baaklini  
Glenn Research Center, Cleveland, Ohio

## The NASA STI Program Office . . . in Profile

Since its founding, NASA has been dedicated to the advancement of aeronautics and space science. The NASA Scientific and Technical Information (STI) Program Office plays a key part in helping NASA maintain this important role.

The NASA STI Program Office is operated by Langley Research Center, the Lead Center for NASA's scientific and technical information. The NASA STI Program Office provides access to the NASA STI Database, the largest collection of aeronautical and space science STI in the world. The Program Office is also NASA's institutional mechanism for disseminating the results of its research and development activities. These results are published by NASA in the NASA STI Report Series, which includes the following report types:

- **TECHNICAL PUBLICATION.** Reports of completed research or a major significant phase of research that present the results of NASA programs and include extensive data or theoretical analysis. Includes compilations of significant scientific and technical data and information deemed to be of continuing reference value. NASA's counterpart of peer-reviewed formal professional papers but has less stringent limitations on manuscript length and extent of graphic presentations.
- **TECHNICAL MEMORANDUM.** Scientific and technical findings that are preliminary or of specialized interest, e.g., quick release reports, working papers, and bibliographies that contain minimal annotation. Does not contain extensive analysis.
- **CONTRACTOR REPORT.** Scientific and technical findings by NASA-sponsored contractors and grantees.

- **CONFERENCE PUBLICATION.** Collected papers from scientific and technical conferences, symposia, seminars, or other meetings sponsored or cosponsored by NASA.
- **SPECIAL PUBLICATION.** Scientific, technical, or historical information from NASA programs, projects, and missions, often concerned with subjects having substantial public interest.
- **TECHNICAL TRANSLATION.** English-language translations of foreign scientific and technical material pertinent to NASA's mission.

Specialized services that complement the STI Program Office's diverse offerings include creating custom thesauri, building customized databases, organizing and publishing research results . . . even providing videos.

For more information about the NASA STI Program Office, see the following:

- Access the NASA STI Program Home Page at <http://www.sti.nasa.gov>
- E-mail your question via the Internet to [help@sti.nasa.gov](mailto:help@sti.nasa.gov)
- Fax your question to the NASA Access Help Desk at 301-621-0134
- Telephone the NASA Access Help Desk at 301-621-0390
- Write to:  
NASA Access Help Desk  
NASA Center for Aerospace Information  
7121 Standard Drive  
Hanover, MD 21076

NASA/TM—2003-212624

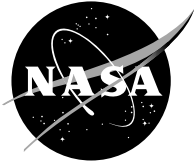

# Vibration Based Crack Detection in a Rotating Disk

## Part 1—An Analytical Study

Andrew L. Gyekenyesi  
Ohio Aerospace Institute, Brook Park, Ohio

Jerzy T. Sawicki  
Cleveland State University, Cleveland, Ohio

George Y. Baaklini  
Glenn Research Center, Cleveland, Ohio

National Aeronautics and  
Space Administration

Glenn Research Center

---

September 2003

## Acknowledgments

The authors would like to thank Richard Martin, Cleveland State University, for his technical support during the assembly of the disk spin system to be utilized in the upcoming experimental verification study.

This report contains preliminary findings, subject to revision as analysis proceeds.

Available from

NASA Center for Aerospace Information  
7121 Standard Drive  
Hanover, MD 21076

National Technical Information Service  
5285 Port Royal Road  
Springfield, VA 22100

Available electronically at <http://gltrs.grc.nasa.gov>

# **Vibration Based Crack Detection in a Rotating Disk Part 1—An Analytical Study**

Andrew L. Gyekenyesi  
Ohio Aerospace Institute  
Brook Park, Ohio  
Email: Andrew.L.Gyekenyesi@grc.nasa.gov

Jerzy T. Sawicki  
Cleveland State University  
Department of Mechanical Engineering  
Cleveland, Ohio  
Email: j.sawicki@csuohio.edu

George Y. Baaklini  
National Aeronautics and Space Administration  
Glenn Research Center  
Cleveland, Ohio  
Email: George.Y.Baaklini@grc.nasa.gov

## **Abstract**

This paper describes the analytical results concerning the detection of a crack in a rotating disk. The concept of the approach is based on the fact that the development of a disk crack results in a distorted strain field within the component. As a result, a minute deformation in the disk's geometry as well as a change in the system's center of mass occurs. Finite element analyses were conducted concerning a notched disk in order to define the sensitivity of the method. The notch was used to simulate an actual crack and will be the method utilized for upcoming experiments. Various notch sizes were studied. The geometric deformations and shifts of center of mass were documented as a function of rotational speed. In addition, a rotordynamic analysis of a 2-bearing, disk and shaft system was conducted. The overall response of the system was required in order to design the experimental system for operation beyond the first critical. The results of the FE analyses of the disk indicated that the overall changes in the disk's geometry and center of mass were rather small. The difference between the maximum centrifugal radial displacements between the undamaged and damaged disks at 8000 RPM was 0.00014 in. for a 0.963 in. notch length. The shift in center of mass was also of this magnitude. The next step involves running experiments to verify the analysis.

## **Introduction**

Rotor health monitoring and on-line damage detection are increasingly gaining the interest of manufacturers of aircraft engines. This is primarily due to the fact that there is a necessity for improved safety during operation as well as a need for lower maintenance costs. Applied techniques for damage detection and health monitoring of rotors are essential for engine safety, reliability and life prediction. Recently, the United States set the ambitious goal of reducing the fatal accident rate for commercial aviation by 80% within ten years [1]. In turn, the National Aeronautics and Space Administration (NASA) in collaboration with Federal Aviation Administration (FAA) and other federal agencies, universities, as well as airline and aircraft industries, responded by developing the Aviation Safety Program (AvSP). The AvSP provides research and technology products needed to help the aerospace

industry achieve the challenge to improve aviation safety. The Nondestructive Evaluation (NDE) Group at the NASA Glenn Research Center at Lewis Field in Cleveland, Ohio is currently addressing the development of propulsion system specific technologies intended to detect damage prior to catastrophe under the propulsion health management task.

Currently, the NDE group is assessing the feasibility of utilizing real-time vibration data for detecting cracks in turbine disks. The data is obtained from radial blade tip clearance and shaft clearance measurements using capacitive or eddy current probes. The concept of the approach is based on the fact that the development of a disk crack results in a distorted strain field within the component. This, in turn, causes a small deformation in the disk's geometry as well as a possible change in the system's center of mass. The geometric change and the center of mass shift are indirectly characterized by monitoring the amplitude and phase of the first harmonic (i.e., the 1x component) of the vibration data. Spin pit experiments and full scale engine tests have been conducted while monitoring for crack growth using the above crack detection methodology [2, 3]. Even so, published data is extremely limited and the basic foundation of the methodology has not been fully studied. This foundation should include a theoretical basis and experimental data to support the models. In addition, the few tests that claimed success have been limited mostly to the spin pit facilities. In spin pits, a vertical, hanging shaft is utilized with only the top having a bearing support. The disk or disks of interest are usually located near the bottom end of the shaft. Because the bottom end of the shaft is unconstrained, it is relatively free to move as a result of any dynamic forces. Therefore, it is assumed that any physical changes in the rotor will induce larger displacement variations in a spin pit set-up than in a more constrained, two bearing system. The analytical model studied here, and the upcoming related experiments, deal with a horizontal shaft supported with end bearings and a centrally located disk. It should be noted that this system is somewhat unique in the arena of spin testing due to the fact that the horizontal shaft is supported by bearings on both ends of the rotor. This is a more realistic representation of an actual turbine as compared to a traditional spin pit.

As mentioned above, the crack detection methodology has only been characterized in a subjective fashion. In addition, the methodology is lacking an in depth modeling campaign. A deeper understanding of the relationship between damage progression and the change in the rotor's center of mass due to the geometric modifications of the damaged disk can be achieved with the implementation of subscale rotor tests with controlled damage levels. The objectives of this study included the design of an optimal subscale disk to represent a full scale turbine disk; finite element analyses of undamaged and damaged disks in order to define the disk's deformation and the resulting shift in center of mass; and rotordynamic modeling of the complete disk and shaft assembly to confirm operation beyond the first critical. The analytical results will be verified in an upcoming experimental study focusing on the design of the laboratory and the implementation of unique and innovative sensors along with the accompanying acquisition/analysis software packages.

### **Finite Element Analysis: Disk Design and Damage Behavior**

The finite element analyses had two goals. The first goal was to design a disk that will achieve the experimental objectives of flaw detection and at the same time be representative of an actual bladed, turbine disk. The second goal was to understand the behavior of the isolated disk as a function of damage state. For this study, the damage was in the form of a notch to be placed in a high stress area of the disk. Such a location allows for maximum geometric deformation. Plots of the maximum radial displacement and shift in center of mass while imposing centrifugal loads were constructed as functions of notch characteristics and rotational speed. Notch tip stresses were documented and will be utilized to define the load limits during the experimental stage of the continuing study.

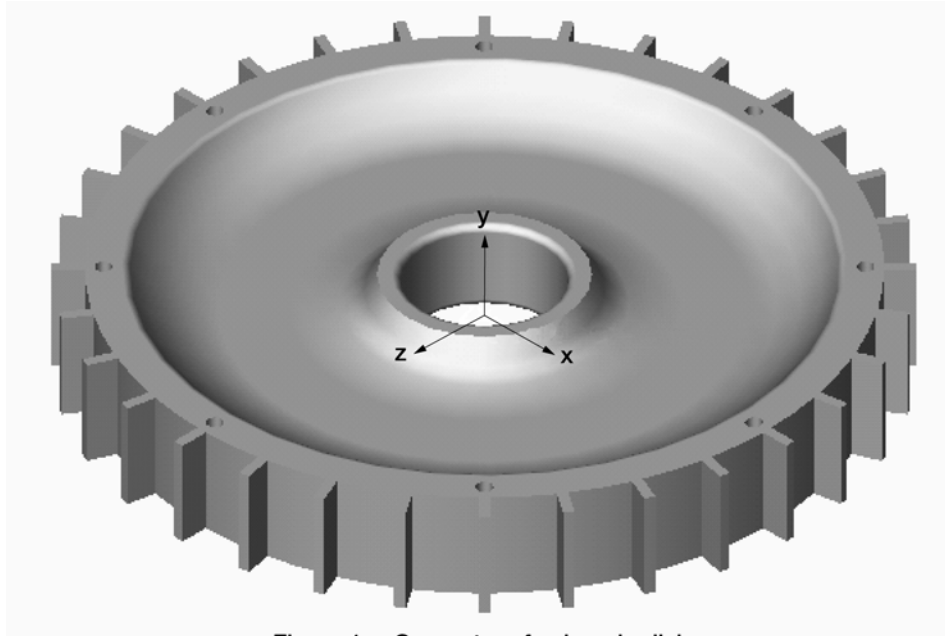

Figure 1.—Geometry of subscale disk.

TABLE I.—PROPERTIES FOR HAYNES NICKEL ALLOY X-750

Density, lb/in <sup>3</sup>	0.3
Modulus of Elasticity, ksi	31000
Poisson's ratio	0.31
Shear Modulus, ksi	11830
Ultimate tensile strength, ksi	145
Yield strength, ksi	95

Figure 1 shows the final design of the subscale disk. The design was based on the fact that the disk should safely handle rotational speeds up to 25000 revolutions per minute (RPM) in the undamaged state as defined by the materials yield stress. A thinned web area and gear teeth were implemented to imitate the web area and blades of a turbine disk. Note that the gear teeth were also needed due to the fact that the capacitive displacement sensors to be utilized during experimentation were designed to monitor radial blade tip clearance. The nickel alloy, Haynes X-750, was the material chosen for the disk. The material properties for Haynes X-750 are listed in Table I. The disk's final design had an outside diameter of 9.25 in. and a bore thickness and outside rim thickness of 1.00 in. and 1.25 in., respectively. The thinnest portion of the web was 0.10 in., with the cross-section and height dimensions of the blades being 1.25 in.  $\times$  0.13 in. and 0.33 in., respectively. Lastly, eight holes, 0.20 in. diameter each, were placed midway in the rim section. The eight holes were spaced every 45°. The holes are to be utilized for possible mass attachments or used for future notch initiation points. During the design and damage study, the finite element analyses (FEA) of the disk were conducted using commercially available FE software. In the analyses, three dimensional brick elements were utilized with an auto-mesh feature to create the model.

Upon completing the subscale disk design, a parametric analysis of the damaged disk was conducted. The damage was in the form of a circumferential notch located in the web region as shown in figure 2. The notch was utilized to represent a crack and is the damage parameter to be implemented in the future experiments. Note that a notch oriented in this way is opened by radial stresses. The circumferential notch



was chosen on the assumption that it would cause the most dramatic change in radial displacement and change in center of mass. The notch width of 0.15 in. was based on the wire thickness and burn area of the electrical discharge machining (EDM) wire.

Figure 2 and Table II list the dimensions associated with the various notch lengths studied. For all cases, the radial distance from the disk center to the plane of the notch was 2.12 in. This corresponded to the location of the maximum radial stress as obtained utilizing the FE stress analysis of the undamaged disk. Figure 3 shows the stress state at the notch tip as a function of notch length and the disk's rotational speed in terms of RPM. The results of the figure will be utilized in defining the experimental notch length and disk speed required to maintain a safe test environment.

TABLE II.—NOTCH DIMENSIONS UTILIZED FOR FINITE ELEMENT ANALYSIS

Angle, degrees	6	12	18	24	26	28	32
Length, in.	0.222	0.444	0.666	0.888	0.962	1.036	1.184

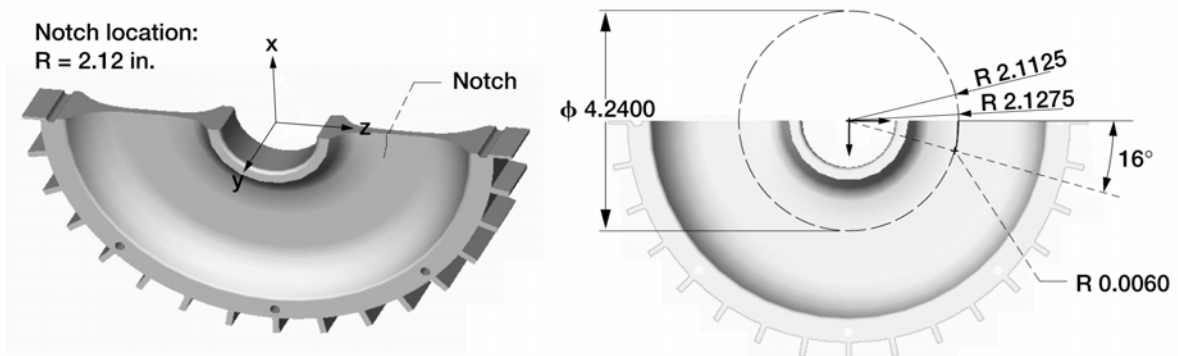

Figure 2.—Notch dimensions for particular case of 1.184 in. notch length (see Table I).

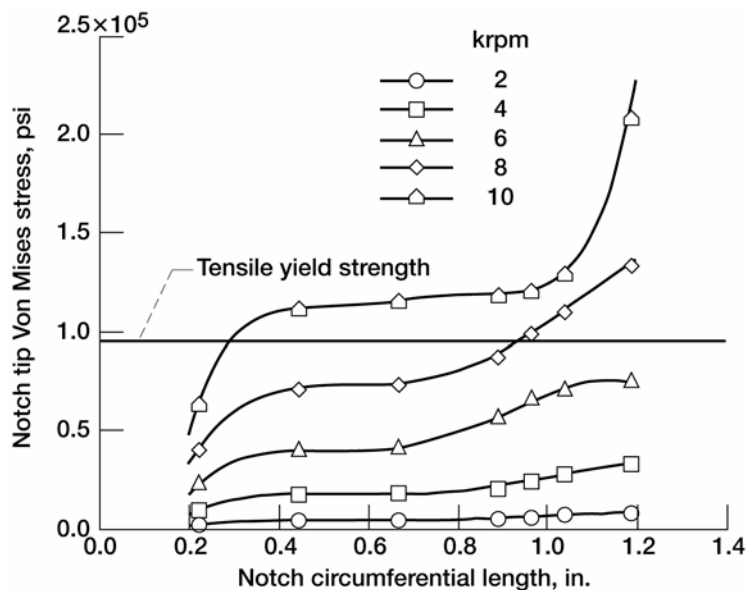

Figure 3.—Von Mises stresses at notch tip as a function of notch length and rpm.

Next, the focus was on the global influence of the notch on the disk's overall displacement behavior while subjected to centrifugal loads. In particular, results were documented concerning the change in maximum centrifugal expansion as measured at the tips of the gear teeth, and the relative shift in center of mass when in the deformed state. These values correspond to values that will be experimentally measured using capacitive displacement probes that monitor the radial blade tip clearance and eddy current probes that monitor radial shaft displacements adjacent to the disk. Figure 4 displays the maximum radial displacement due to centrifugal expansion as a function of notch length and rotational speed, while figure 5 displays the net change after subtracting the displacement values of an undamaged disk.

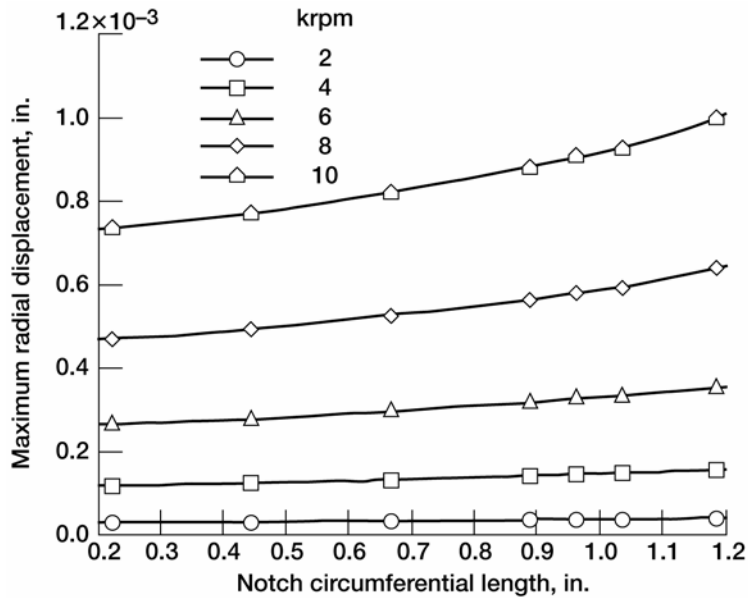

Figure 4.—Maximum radial displacements as a function of notch length and disk rpm.

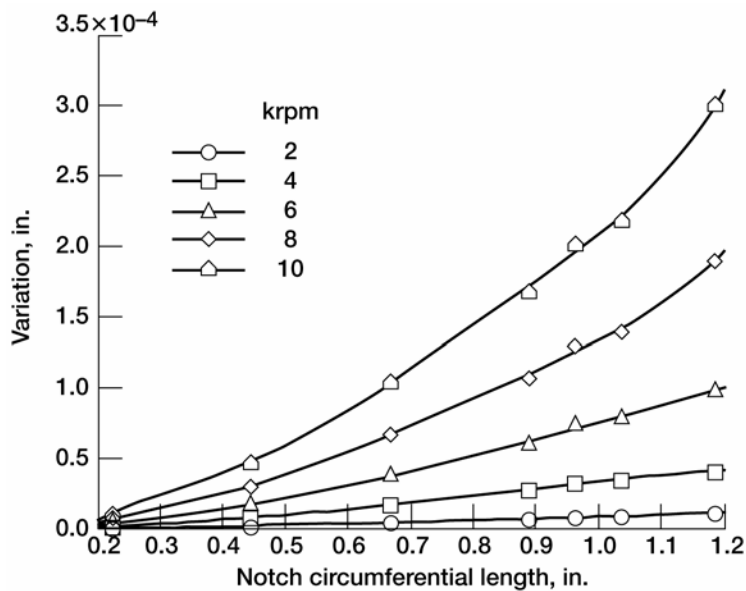

Figure 5.—Net radial displacements after subtracting displacement values from undamaged disk.

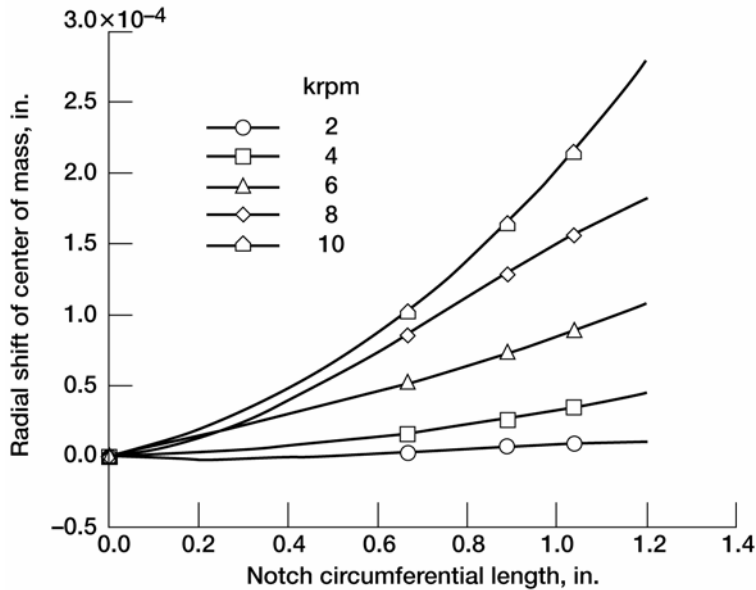

Figure 6.—Radial shift of center of mass as a function of notch length and disk rpm.

Viewing figures 4 and 5, it was apparent that the notch induced changes in maximum displacement were rather small. For example, the net change in the maximum radial displacement of a notched disk (notch length = 0.962 in.) at 8000 RPM was 0.00014 in. This particular set of parameters was of interest due to the fact that it will be experimentally feasible to test these conditions since the notch tip stress was maintained below the yield strength of the material (see figure 3).

Next, parameters from the FE model (e.g., the mass matrix and node displacements while in the deformed state) were utilized together with the equations of basic engineering mechanics to calculate the disk's shift in center of mass [4]. Figure 6 shows the approximate shift in the center of mass as a function of notch length and rotational speed. The values were similar in scale to the net change in radial displacement (see figure 5). Therefore, the global influence of the notch was revealed both in the deformation of the disk, as indicated by the change in the disk's maximum radial displacement, and in the isolated disk's center of mass shift. If other factors relating to the single disk system studied here were to remain unchanged (e.g., shaft, bearings, etc.), the change in the disk's center of mass should equivalently influence the center of mass shift for the total rotor system.

### Rotordynamic Analysis

The following rotordynamic analysis was conducted to further understand the dynamic behavior of the experimental set-up. In most aviation based turbines, the system is expected to operate at some speed above the first critical. The disk spin simulation system being assembled for this continuing study consists of a shaft having a diameter of 0.79 in. and a length of 30.75 in., supported by precision angular contact ball bearings that are assumed to provide isotropic stiffness. The single disk, as seen in figure 1, is mounted at the mid-span of the shaft. The disk's diametral and polar moments of inertia are 63.27 and 126.53 lbm-in<sup>2</sup>, respectively. The weight of the disk is 10.75 lbf.

The equations of motion for the rotor system are

$$M\ddot{q} + C(\Omega)\dot{q} + Kq = F(t) \quad (1)$$

where  $q$  denotes the displacement vector;  $M$  is the symmetric mass matrix;  $C(\Omega)$  is an asymmetric matrix that includes an antisymmetric, speed-dependent gyroscopic matrix; and  $K$  is the symmetric stiffness matrix. The right hand side of equation (1) represents the force excitation vector resulting from the system's residual imbalance as well as any additional imbalance that may result from the disk damage (i.e., notch).

The system's natural frequencies are the result of the solution of homogeneous version of equation (1), and can be written as

$$\lambda_i = -u_i + jv_i \quad (2)$$

or, in a single degree of freedom form as

$$\lambda_i = -\frac{\xi_i \omega_{di}}{\sqrt{1 - \xi_i^2}} \pm j\omega_{di} \quad (3)$$

where  $\omega_{di} = v_i$  is the  $i^{th}$  damped natural frequency, and  $\xi_i = \frac{u_i}{\sqrt{u_i^2 + v_i^2}}$  the corresponding modal damping

ratio. The values of  $\omega_{di}$  are directly used for the construction of the whirl speed map (i.e., Campbell diagram). The real part of  $\lambda_i$  indicates the possible instability of the system.

Figure 7 is the Campbell diagram for the current experimental system. The intersection points of synchronous excitation line 1X with the loci of natural frequencies determine the critical speeds. It should be noted that the rotor set-up utilized here resembles a Jeffcott rotor [5] with the rigid disk located at the center of the flexible shaft, and therefore, the translational and rotational motions were statically and dynamically decoupled. Concerning the translational motion, the first two natural frequencies of whirl (forward and backward) were independent of the rotor spin speed due to the absence of gyroscopic moments. The first synchronous critical speed, i.e., the rotor spin speed associated with a resonance condition, was 2610 RPM. During this condition, the maximum shaft displacement was at the shaft midpoint as seen in Figure 8. The second forward critical speed was at 28153 RPM. This value was beyond the operational speed of the test system which is approximately 10000 RPM.

Figure 9 displays the amplitude and phase of the 1x component in the form of Bode plots. The first critical at 2610 RPM is indicated by the frequency at which the amplitude peaks and a phase inversion occurs. Also, note that for this particular system that the radial displacements at the disk location settled to a relatively constant value after the first critical speed was traversed.

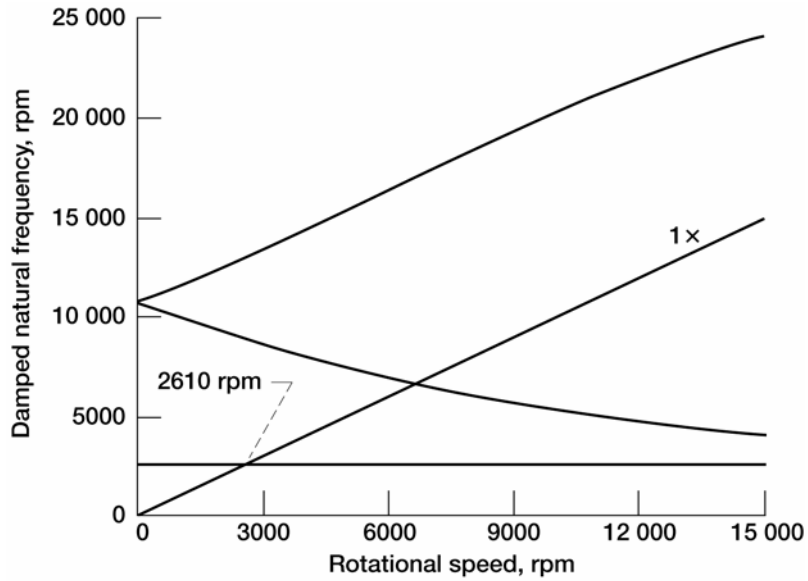

Figure 7.—Campbell diagram for rotor test system.

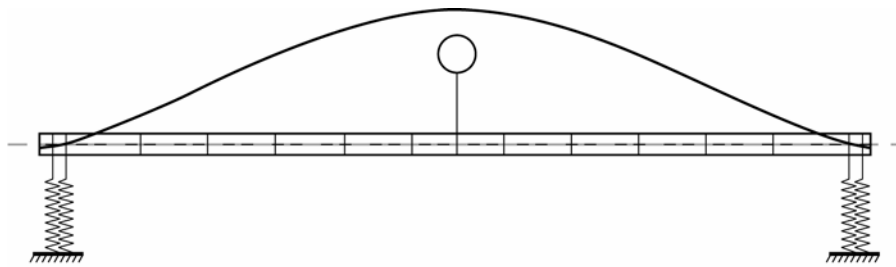

Figure 8.—Mode shape of vibration for rotor at speed of 2610 rpm.

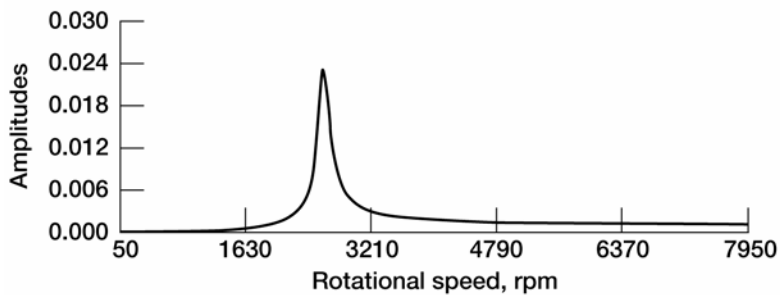
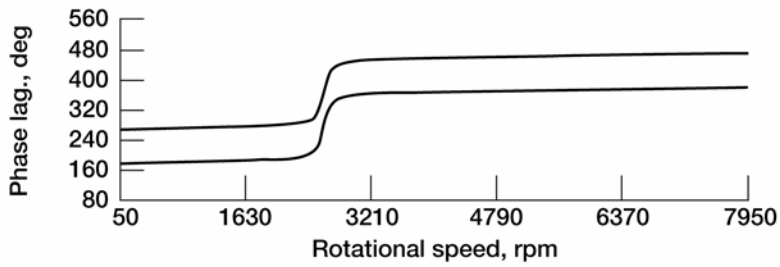

Figure 9.—Bode plot of 1x component calculated using an assumed unbalance of 5 oz.

The critical speed map, which plots the critical speeds of the system versus the range of bearing stiffness, is presented in figure 10. It is a log-log plot showing the variation of critical speeds for a bearing stiffness range of  $1 \times 10^3$  to  $1 \times 10^7$  lb/in. Note that for values above a stiffness of  $1 \times 10^7$  lb/in., the first critical speed did not increase.

Based on the results of the rotordynamic analysis, the experimental system was correctly assembled to operate beyond the first critical speed. Note that the second critical speed was defined by the shaft having an “S” shape with zero displacements at the shaft mid-point and the end bearings. Therefore, similar to the Jeffcott rotor analysis [5], the system’s synchronous radial displacement at the center of the shaft should stay constant beyond the first critical and be a function of the system’s residual imbalance. It has been proposed that a cracked disk may have a changing imbalance due to the crack opening as a function of rotational speed [2]. This is contrary to the assumption of a rigid disk. As a result, the amplitude of the synchronous displacement may grow as a function of speed when operating beyond the first critical as opposed to being constant. This also will be explored during the experimentation as a possible indicator of disk damage. An upcoming analytical study by the authors will address the speed dependence of the disk’s eccentricity vector and the influence it may have on the post critical speed behavior.

Based on the results of the rotordynamic analysis, the experimental system was correctly assembled to operate beyond the first critical speed. Note that the second critical speed was defined by the shaft having an “S” shape with zero displacements at the shaft mid-point and the end bearings. Therefore, similar to the Jeffcott rotor analysis [5], the system’s synchronous radial displacement at the center of the shaft should stay constant beyond the first critical and be a function of the system’s residual imbalance. It has been proposed that a cracked disk may have a changing imbalance due to the crack opening as a function of rotational speed [2]. This is contrary to the assumption of a rigid disk. As a result, the amplitude of the synchronous displacement may grow as a function of speed when operating beyond the first critical as opposed to being constant. This also will be explored during the experimentation as a possible indicator of disk damage. An upcoming analytical study by the authors will address the speed dependence of the disk’s eccentricity vector and the influence it may have on the post critical speed behavior.

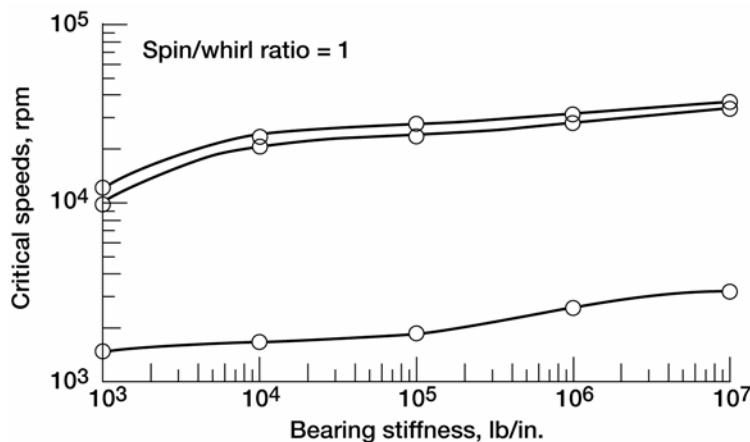

Figure 10.—Critical speed map as function of bearing stiffness for three lowest critical speeds.

## Conclusions

Due to an increased interest concerning the health monitoring of cracked disks in turbine engines, a study was required to address the feasibility of utilizing vibration data as a tool for recognizing disk damage prior to catastrophic failure. The concept of the approach is based on the fact that the development of a disk crack results in a distorted strain field within the component. This may cause a measurable deformation in the disk's geometry and a corresponding change in the system's center of mass. The geometric change and the center of mass shift are indirectly characterized by monitoring the amplitude and phase of the first harmonic (i.e., the 1x component) of the vibration data. The experimental data can be captured by monitoring displacements at either the shaft or blade tips. Because of the limited publications concerning the technique and the lack of a basic methodology, the authors undertook the task of conducting a modeling campaign as well as preparing the ground work for the experimentation.

The objectives were met by designing a subscale disk and analyzing the stress states in the undamaged state and the notched condition. The disk's maximum radial displacements and shifts in center of mass were defined as functions of notch length and rotational speed. It was seen that the relative changes in these parameters were on the order of 0.00014 in. for a 0.962 in. notch in the web area of the disk while rotating at 8000 RPM. This value is close to the resolution limits of the displacement sensors to be used during the experimentation. The rotordynamic analysis revealed that the experimental system's first critical, assuming a flexible shaft and rigid disk, is 2610 RPM. At this point, it is assumed that the experiments will be operated in the range of 0 to 8000 RPM. This allows for plenty of post critical operation and at the same time staying within the notched disk's material limits.

Upcoming studies from the authors concerning this topic, will include an in depth experimental study to verify the above analytical results as well as modifying the Jeffcott rotor analysis to include a speed dependent eccentricity vector for the disk. As mentioned above the finite element modeling effort indicated relatively small global deformations close to the resolution limits of the existing sensors. The subscale experiments, with the inclusion of naturally existing mechanical and electronic noise, will help define the true sensitivity of the damage detection methodology.

## References

1. Shin, J., "The NASA Aviation Safety Program Overview," *Proceedings of ASME Turbo Expo 2000*, May 8-11, 2000, Munich, Germany.
2. Haase, W.C., and Drumm, M.J., "Detection, Discrimination, and Real-Time Tracking of Cracks in Rotating Disks," *SPIE's NDE and Health Monitoring of Aerospace Materials and Civil Infrastructures*, San Diego, California, March, 2002.
3. Sonnichsen, H.E., and Milatovic, B., "Detecting Anomalies in Rotating Components," United States Patent 6456945 B1, September 24, 2002.
4. Beer, F.P. and Johnston, Jr., E.R., "Vector Mechanics for Engineers," New York, McGraw-Hill Book Company, 1984.
5. Vance, J.M., "Rotordynamics of Turbomachinery," New York, A Wiley-Interscience Publication, 1988.

# REPORT DOCUMENTATION PAGE

*Form Approved*  
*OMB No. 0704-0188*

Public reporting burden for this collection of information is estimated to average 1 hour per response, including the time for reviewing instructions, searching existing data sources, gathering and maintaining the data needed, and completing and reviewing the collection of information. Send comments regarding this burden estimate or any other aspect of this collection of information, including suggestions for reducing this burden, to Washington Headquarters Services, Directorate for Information Operations and Reports, 1215 Jefferson Davis Highway, Suite 1204, Arlington, VA 22202-4302, and to the Office of Management and Budget, Paperwork Reduction Project (0704-0188), Washington, DC 20503.

<b>1. AGENCY USE ONLY</b> ( <i>Leave blank</i> )		<b>2. REPORT DATE</b> September 2003	<b>3. REPORT TYPE AND DATES COVERED</b> Technical Memorandum	
<b>4. TITLE AND SUBTITLE</b> Vibration Based Crack Detection in a Rotating Disk Part 1—An Analytical Study			<b>5. FUNDING NUMBERS</b>  WBS-22-728-30-06	
<b>6. AUTHOR(S)</b>  Andrew L. Gyekenyesi, Jerzy T. Sawicki, and George Y. Baaklini				
<b>7. PERFORMING ORGANIZATION NAME(S) AND ADDRESS(ES)</b>  National Aeronautics and Space Administration John H. Glenn Research Center at Lewis Field Cleveland, Ohio 44135-3191			<b>8. PERFORMING ORGANIZATION REPORT NUMBER</b>  E-14182	
<b>9. SPONSORING/MONITORING AGENCY NAME(S) AND ADDRESS(ES)</b>  National Aeronautics and Space Administration Washington, DC 20546-0001			<b>10. SPONSORING/MONITORING AGENCY REPORT NUMBER</b>  NASA TM-2003-212624	
<b>11. SUPPLEMENTARY NOTES</b>  Andrew L. Gyekenyesi, Ohio Aerospace Institute, Brook Park, Ohio 44142; Jerzy T. Sawicki, Cleveland State University, Cleveland, Ohio 44115; and George Y. Baaklini, NASA Glenn Research Center. Responsible person, Andrew L. Gyekenyesi, organization code 5520, 216-433-8155.				
<b>12a. DISTRIBUTION/AVAILABILITY STATEMENT</b>  Unclassified - Unlimited Subject Categories: 31, 05, 07, 35, and 03                      Distribution: Nonstandard  Available electronically at <a href="http://gltrs.grc.nasa.gov">http://gltrs.grc.nasa.gov</a> This publication is available from the NASA Center for AeroSpace Information, 301-621-0390.			<b>12b. DISTRIBUTION CODE</b>	
<b>13. ABSTRACT</b> ( <i>Maximum 200 words</i> )  This paper describes the analytical results concerning the detection of a crack in a rotating disk. The concept of the approach is based on the fact that the development of a disk crack results in a distorted strain field within the component. As a result, a minute deformation in the disk's geometry as well as a change in the system's center of mass occurs. Finite element analyses were conducted concerning a notched disk in order to define the sensitivity of the method. The notch was used to simulate an actual crack and will be the method utilized for upcoming experiments. Various notch sizes were studied. The geometric deformations and shifts of center of mass were documented as a function of rotational speed. In addition, a rotordynamic analysis of a 2-bearing, disk and shaft system was conducted. The overall response of the system was required in order to design the experimental system for operation beyond the first critical. The results of the FE analyses of the disk indicated that the overall changes in the disk's geometry and center of mass were rather small. The difference between the maximum centrifugal radial displacements between the undamaged and damaged disks at 8000 rpm was 0.00014 in. for a 0.963 in. notch length. The shift in center of mass was also of this magnitude. The next step involves running experiments to verify the analysis.				
<b>14. SUBJECT TERMS</b>  Health monitoring; Crack detection; Center of mass			<b>15. NUMBER OF PAGES</b> 16	
			<b>16. PRICE CODE</b>	
<b>17. SECURITY CLASSIFICATION OF REPORT</b> Unclassified	<b>18. SECURITY CLASSIFICATION OF THIS PAGE</b> Unclassified	<b>19. SECURITY CLASSIFICATION OF ABSTRACT</b> Unclassified	<b>20. LIMITATION OF ABSTRACT</b>	