

## SMU Journal of Undergraduate Research

---

Volume 2

Article 3

---

2019

# Electrical System for Bioelectric Impedance using AD5933 Impedance Converter

Allison Garcia

*Southern Methodist University*, [agarcia@smu.edu](mailto:agarcia@smu.edu)

Ahmet C. Sabuncu

*Worcester Polytechnic Institute*, [acsabuncu@wpi.edu](mailto:acsabuncu@wpi.edu)

Follow this and additional works at: <https://scholar.smu.edu/jour>

 Part of the [Biomedical Engineering and Bioengineering Commons](#), and the [Engineering Science and Materials Commons](#)

---

### Recommended Citation

Garcia, Allison and Sabuncu, Ahmet C. (2019) "Electrical System for Bioelectric Impedance using AD5933 Impedance Converter," SMU Journal of Undergraduate Research: Vol. 4 , Article 3. DOI: <https://doi.org/10.25172/jour.4.1.3>

This Article is brought to you for free and open access by SMU Scholar. It has been accepted for inclusion in SMU Journal of Undergraduate Research by an authorized administrator of SMU Scholar. For more information, please visit <http://digitalrepository.smu.edu>.

# Electrical System for Bioelectric Impedance using AD5933 Impedance Converter

Allison Garcia\* and Ahmet C. Sabuncu

agarcia@smu.edu

## ABSTRACT

Benchtop lab equipment, such as the HP4194A Precision Impedance Analyzer, offer accuracy and functionality but are often expensive and bulky. Although integrated circuits offer less functionality than benchtop equivalents, they can be a cheaper alternative for smaller applications. In this study, the AD5933 Impedance Converter was investigated as a low-cost option for impedance analysis of the bicep brachii. The AD5933 evaluation board was properly calibrated to measure human muscle by using an equivalent parallel circuit consisting of a 5 nF capacitor and a 1 kOhm resistor. Next, the impedance of the bicep was measured using the AD5933 as the experimental device and the HP4194A as the control device. A 2 volt peak-to-peak signal was generated for a 10 kHz to 100 kHz frequency range and the resulting impedance of the bicep was measured. The AD5933 recorded impedance curves qualitatively and quantitatively similar to those recorded by the HP4194A. Thus, the AD5933 was considered to be a low-cost alternative for impedance analysis in small-scale medical applications.

range necessary for measuring the human bicep brachii.

## 1. INTRODUCTION

Bioelectric impedance analysis (BIA) is a medical practice used to measure body composition. It works by utilizing the concepts of Ohms law,  $V = IZ$ : by applying a known voltage and measuring the current from the sample under test, the unknown impedance can be determined [6]. The different voltage potential at either end of the sample causes current, which is the flow of electrons and ions. Impedance is the resistance of the material to the flow of current [6]. In an AC circuit, the voltage and current signals vary with time. As a result, the impedance is represented as a complex number,  $Z = R + jX$ , to reflect this variance. The real part of impedance is called resistance,  $R$ , and the imaginary part is called reactance,  $X$  [6].

In most medical applications, impedance is measured by hospital-grade equipment. Outside of a hospital, large lab equipments such as the HP4194A Precision Impedance Analyzer, are used to measure impedance [5]. These devices are highly accurate and can perform large frequency sweeps such as 40 Hz to 110 MHz. The size and price make this kind of equipment impractical for low-cost medical applications. Integrated circuit (IC) impedance analyzers present a viable alternative to bulky lab equipment. The AD5933 Impedance Converter from Analog Devices and the AFE4300 Body Composition Analog Front End from Texas Instruments are two examples of commercial ICs that perform impedance analysis [1] [8]. These devices operate on a much smaller frequency sweep, such as 10 kHz to 100 kHz for the AD5933, but they have the advantage of portability and lower cost. They can be integrated into reasonably priced products for the general public. This work will show that the AD5933 chip and its evaluation board can produce comparable results to the HP4194A lab equipment for the frequency and impedance

## 2. IMPEDANCE ANALYZER CHIP

The AD5933 impedance analyzer was selected for this project because of the capabilities of the chip and the features of the evaluation board and its software.

### *Analog Devices AD5933*

The AD5933 is a twelve-bit impedance converter integrated circuit manufactured by Analog Devices. Measuring impedance with this device can be broken down into three distinct stages: the transmit stage, the receive stage, and the signal processing stage [1]. The chip generates a sine voltage wave,  $V_{out}$ , at a known frequency and transmits it to the sample under test. The sample is the unknown impedance and it is connected between the  $V_{out}$  and  $V_{in}$  pins [1].  $V_{out}$  is the generated voltage wave and  $V_{in}$  is a virtual ground.  $V_{out}$  enters the sample and encounters resistive and reactive effects, which together are known as impedance. The change in electrical potential between  $V_{out}$  and  $V_{in}$  caused by the impedance is measured during the receive stage. Additionally, the AD5933 chip uses a transimpedance amplifier to convert the current flowing through the unknown impedance back to a voltage signal [1]. A transimpedance amplifier produces a voltage output when given a current input [4]. The amplifier is named for its gain,  $\frac{V_{out}}{I_{in}}$ , which is measured in Ohms, the same units as impedance and resistance. This second  $V_{out}$  voltage is used to digitize the analog data collected from the sample so it can be used in signal processing. A Discrete Fourier Transform (DFT) algorithm is used to calculate the real and imaginary parts of impedance [1].

\* Mentor: Dr. Ahmet Can Sabuncu, Clinical Assistant Professor of Mechanical Engineering, Lyle School of Engineering, Hunt Institute Fellow

Figure 1 depicts the electrical block diagram of the AD5933 [7]. The blue highlighted section represents the transmit stage with a sine function as  $V_{out}$ . The impedance under test is marked  $Z(\omega)$ . The green highlighted section depicts the current-to-voltage transimpedance amplifier and the analog to digital converter. Finally, the red highlighted region shows where the DFT is performed to calculate the complex impedance for the sample based on the excitation signal.

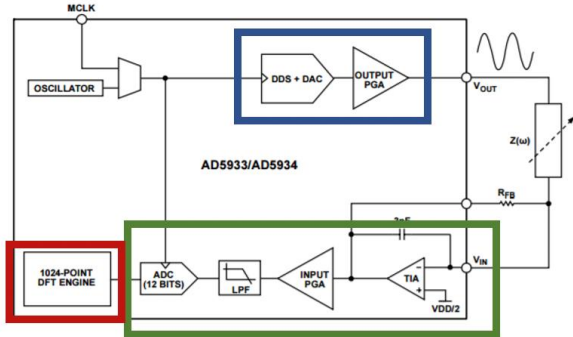

Figure 1. Electrical Block Diagram of AD5933 with transmit stage (blue), receive stage (green) and signal processing engine (red) highlighted [7].

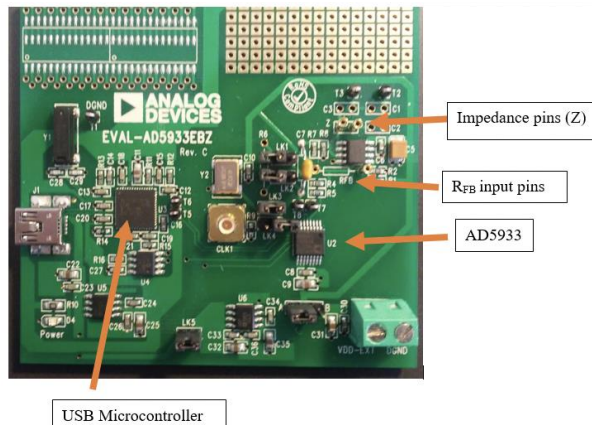

Figure 2. Evaluation Board for AD5933

### Evaluation Board for AD5933

Physically, the AD5933 is an IC housed in a black plastic package with approximately  $5\text{mm}^2$  [1]. At this level, the inputs and outputs of the chip are accessible only by 16 small metal pins [1]. It is common industry practice to use an evaluation board to have easier access to the chip inputs and outputs. The AD5933 is permanently mounted to the evaluation board along with external circuitry that aids in measurement and a microcontroller that governs interactions between the chip and a computer [3]. For this study, the evaluation board was purchased from Analog Devices because of the ease of access to inputs and outputs it provided. Creating a new printed circuit board using the AD5933 at the IC level was beyond the scope of work.

Another advantage to using the evaluation board was access to Analog Device software that allowed us to program the board from a computer. The board connects to a personal computer via a USB port for communication and

power. The software allows the user to program the voltage level and frequency sweep of the transmitted signal [2]. After the signal is received from the sample under test, the software graphs the magnitude and phase of the measured impedance. The raw data can also be downloaded into a comma delimited .csv file [2].

### Taking Impedance Measurements

1) *Frequency Sweep Parameters:* The first step in taking impedance measurements is selecting the parameters of the voltage frequency sweep [1]. To create a sweep of 10 kHz to 100 kHz, the user selects the start frequency, the number of increments and the spacing between increments [2]. These parameters are written to the device by the evaluation software. The AD5933 chip then generates a 2 V peak-to-peak voltage signal with the given frequency parameters [1].

2) *The Feedback Resistor:* Next, the AD5933  $R_{cal}$  and  $R_{FB}$  resistor values must be calculated for calibration and feedback. The feedback resistor  $R_{FB}$  is used to adjust the gain of the transimpedance amplifier to avoid clipping of the signal. If clipping occurs and the signal saturates, the signal will be distorted during the Fourier Transform [7]. The programmable gain amplifier (PGA) is also used to adjust the gain of the signal to prevent clipping. Equation 1 shows the equation used to calculate  $R_{FB}$ .

$$(1) R_{FB} = \frac{\left(\frac{V_{DD}}{2} - 0.2\right) * Z_{MIN}}{\left(V_{PK} + \frac{V_{DD}}{2} - V_{DCOFFSET}\right)} * \frac{1}{GAIN}$$

In this equation:

$V_{PK}$  is the peak voltage of the selected output range,

$Z_{MIN}$  is the minimum impedance (see equation 3),

The GAIN is the selected PGA gain, x1 or x5,

$V_{DD}$  is the supply voltage,

$V_{DCOFFSET}$  is the DC offset voltage for the selected range [7].

3) *Gain Factor Calculation:* The second resistor required to program the AD5933 is the calibration resistor,  $R_{cal}$ . The AD5933 performs a DFT analysis for each frequency point in the selected sweep [1]. The DFT results in a real and imaginary number that must be multiplied by a scaling factor to obtain the final impedance value [7]. This scaling factor is called the gain factor and it is calculated while calibrating the device with a known impedance,  $R_{cal}$ , connected across the Z pins shown in figure 2 [7]. This calibration resistor is calculated using equation 2.

$$(2) R_{CAL} = (Z_{MIN} + Z_{MAX}) * \frac{1}{3}$$

$Z_{MIN}$  and  $Z_{MAX}$  are the minimum and maximum impedance values for the frequency sweep and are calculated using equations 3 and 4.

$$(3) |Z_{MIN}| = \frac{R}{\sqrt{1^2 + (2\pi R C f_{MAX})^2}}$$

$$(4) |Z_{MAX}| = \frac{R}{\sqrt{1^2 + (2\pi RCf_{MIN})^2}}$$

In these equations R is resistance, C is capacitance of the impedance, and  $f_{MIN}$  and  $f_{MAX}$  are the minimum and maximum values of the frequency sweep.

4) *The Calibration Process:* Calibration with the gain factor is only performed one time after the evaluation board is connected to the computer. For each subsequent measurement,  $R_{cal}$  is removed and an unknown impedance can be placed across the Z pins. Because impedance is a complex number, it is necessary to know the phase as well as the magnitude. The phase of the unknown impedance is calculated by taking the difference between the calibrated phase and the unknown phase measured by the device [7]. Because of this, it is important that a resistor, which has a phase of zero, is used as the known impedance during calibration rather than a capacitor or an RC circuit with a non-zero phase response [7]. It is also advisable to use as small a frequency range as possible for the frequency sweep to avoid errors introduced by the gain factor varying with frequency [7].

5) *Parameters Chosen for Study:* For this project, a frequency sweep of 1 kHz to 100 kHz was selected for a 5 nF capacitor in parallel with a 1 kOhm resistor based on preliminary measurements of human resistance and capacitance. Using these values and equations 1 and 2,  $R_{FB}$  was calculated to be 200 Ohms and  $R_{cal}$  was found to be 500 Ohms. After calibration was complete,  $R_{cal}$  was removed from the Z pins and replaced with wires that were connected to electrodes on the patient's bicep.

### 3. PRELIMINARY MEASUREMENTS FOR HUMAN STUDY

In all applications, the impedance under test is part of an electrical circuit. When the impedance is a known resistance or capacitance, the impedance can be easily calculated using circuit analysis equations and theory. The first portion of this study involved learning how to use the AD5933 evaluation board to take reliable measurements for known resistors and capacitors, such as the 5 nF and 1 kOhm parallel RC circuit. This was achieved through extensive research in Analog Devices documentation. However, the ultimate goal of this project was to use an impedance analyzer to measure the impedance of a human bicep. The resistive and capacitive properties of human skin and muscle are more complex than a single RC circuit, so an equivalent circuit model must be used to approximate the resistance and capacitance encountered by the impedance analyzer.

To obtain the most accurate readings from the impedance analyzer, it is important that the calibration resistor is between the  $Z_{min}$  and  $Z_{max}$  values of the frequency sweep [7]. When a value outside of the allowable impedance range for a given frequency sweep is measured, data collected is not reliable when compared to circuit theory. To choose a reasonable value for  $R_{cal}$ , preliminary measurements of human resistance and capacitance were taken experimentally using the HP4194A Impedance Analyzer. Based on the small sample size of 6 people, a 5 nF capacitor in parallel with a 1 kOhm resistor was determined as an approximation for bicep impedance and served as the

equivalent circuit model of the human bicep for this experiment. These values were then used to calculate specific values of  $R_{cal}$  and  $R_{FB}$ . The evaluation board was then calibrated with these resistors. The evaluation software graphed the magnitude,  $|Z|$ , and phase,  $\theta$ , of the impedance  $Z = |Z|e^{j\theta}$ . Figure 3 shows a comparison of impedance magnitude between the data experimentally obtained by the calibrated evaluation board and the expected magnitude values calculated from equation 5 [7].

$$(5) Z_{Total} = \frac{R}{1 + RCj\omega}$$

For the 10 kHz to 100 kHz frequency sweep, the curves for both the measured and calculated data exhibit a similar shape, as shown in figure 3. The maximum percent error between the two data sets is 50.7 percent. However, this does not take into account the semi-constant offset between the two curves. This offset could be explained by resistor tolerances in  $R_{cal}$  and  $R_{FB}$ , lead resistance and inductance, or stray capacitance from the experimental setup of the wires connecting the two electrodes. For this experiment, the offset was considered acceptable and the preliminary measurements taken using the HP4194A Impedance Analyzer were accurate enough to calculate  $R_{cal}$  and  $R_{FB}$  for our human study.

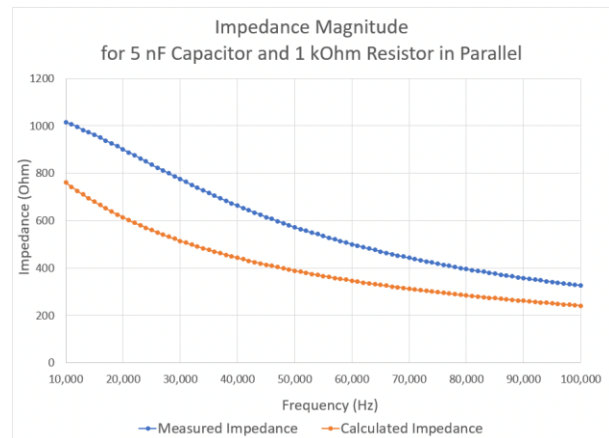

Figure 3. Comparison of measured values and calculated values for a 10 kHz to 100kHz frequency sweep of a 5 nF capacitor and a 1 kOhm resistor in parallel.

### 4. USE OF AD5933 EVALUATION BOARD IN HUMAN STUDY

The AD5933 played an integral part in the human study for this project. The research study was granted approval from the Southern Methodist University Institutional Review Board and all research team members received proper training to carry out the experiment. Seventy volunteers over the age of 20 participated in the study. The volunteers were asked to flex their bicep and two tabbed, medical grade, ECG electrodes were placed 5 cm apart centered around the apex of the muscle. The distance between the electrode wires was held constant by the apparatus shown in figure 4 to eliminate the variation in stray capacitance between the wires. Impedance measurements

were taken in three distinct positions of the dominant arm: resting at 180 degrees, resting with the arm bent at 90 degrees and actively using the bicep by holding an 8lb weight at 90 degrees (figure 4). The same series of measurements were taken using the AD5933 evaluation board as well as the HP4194A Impedance Analyzer. Each measurement was repeated in triplicate to ensure the reproducibility of the results. The HP4194A was the control device because it is a well-known piece of lab equipment. The AD5933 evaluation board was the experimental device. The electrical purpose of this study was to determine if the AD5933 could take data comparable to HP4194A for bicep impedance measurements. Establishing the AD5933 as a reliable device then allowed other members of the team to perform other medical and statistical calculations related to muscle quality.

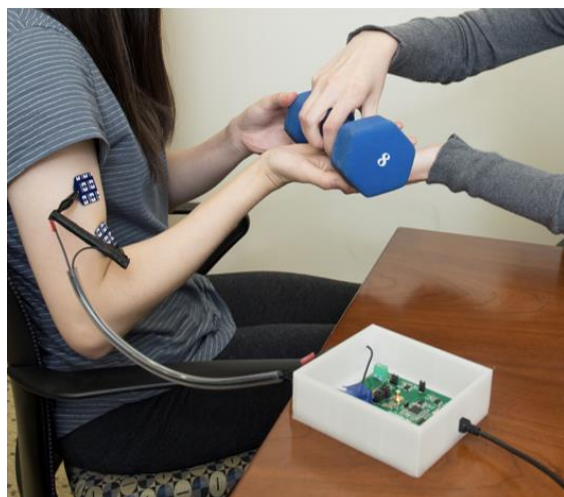

Figure 4. Researcher hands study participant 8lb weight to test bicep impedance using AD5933 apparatus. Weight is held in dominant hand with arm bent at 90 degrees

### 5. DATA ANALYSIS OF HUMAN STUDY

The human study was conducted over a period of two weeks and the data was analyzed at its conclusion. For the specific 10 kHz to 100 kHz frequency range, both the AD5933 and the HP4194A control device collected 101 data points. However, the AD5933 used a linear scale while the HP4194A used a log scale. This meant that the data could not be plotted on the same graph, which was necessary for comparing data. A MATLAB (MathWorks, Natick, Massachusetts) script was written that mapped the original distribution of points to a common log scaling of 75 points between 10 kHz and 100 kHz. This allowed both data sets to be plotted on the same graph. Data from a single participant is presented here. The recorded impedance ( $Z$ ) was mathematically converted to resistance ( $R$ ) and capacitance ( $C$ ) using equations 6 and 7 to match the equivalent circuit model of a resistor and capacitor in parallel.

$$(6) Z = R + jX$$

$$(7) C = \frac{1}{2\pi fZ}$$

For the capacitance spectrum shown in figure 5, the max difference between the two measurements is 4.4 nF, which represents an error of 21 percent. This difference decreases as frequency increases. Both devices recorded the same capacitance at approximately 70 kHz. For the resistance spectrum in figure 6, the minimum distance between the measurements is 101.1 Ohm at 20 kHz and it increases to 142.3 Ohm at 100kHz. This represents a change in error from 17.6 percent to 30 percent. However, the overall shape of the graph is similar if adjusted for a constant offset, potentially created by lead resistance and lead inductance. The spectra of three other people in the preliminary data analysis show the same behavior for capacitance and resistance. This suggests that the AD5933 can provide similar results for the impedance measurements taken between 10 kHz to 100 kHz.

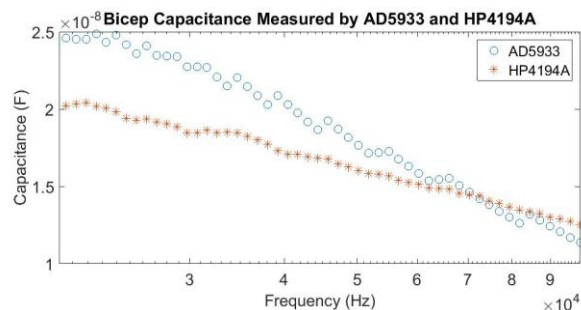

Fig. 5. Bicep capacitance measured by both the AD5933 and HP4194A for 20 kHz to 100 kHz.

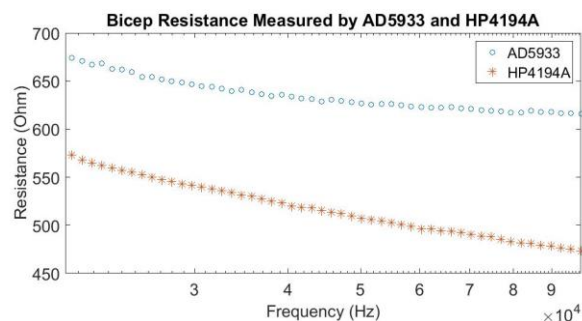

Figure 6. Bicep resistance measured by both the AD5933 and HP4194A for 20 kHz to 100 kHz.

Finally, the responses of AD5933 and HP4194 devices are compared in determining body composition. Two representative samples of significantly different body compositions, Subject #31 and #5, are selected for comparison. These subjects will be denoted Subjects A and B in the rest of the paper, respectively. In the experiments, the impedance responses of the subjects were measured when subjects' arms were vertical to the ground plane. The experiments were conducted with AD5933 and HP4194 in identical replications. In addition to the impedance measurements, some vital parameters, such as body temperature, body mass index, were measured. These

additional measurements of the subjects are summarized in figure 7.

| Subject | Age | Gender | Body Fat % | BMI  | Temperature (F) |
|---------|-----|--------|------------|------|-----------------|
| A       | 40  | Female | 19.4       | 17.6 | 96.4            |
| B       | 42  | Female | 42.2       | 34.4 | 94.3            |

Fig. 7. Vital parameters for Subjects A and B

In figures 8 and 9, impedance magnitudes of Subjects A and B are shown for HP and AD devices, respectively. While the magnitudes are slightly different in these figures among HP and AD devices, the overall shape of the curves are similar. The AD device was able to capture the approximately 100-ohm impedance difference between Subjects A and B at 10 kHz. The impedance magnitude difference monotonically increases in both devices.

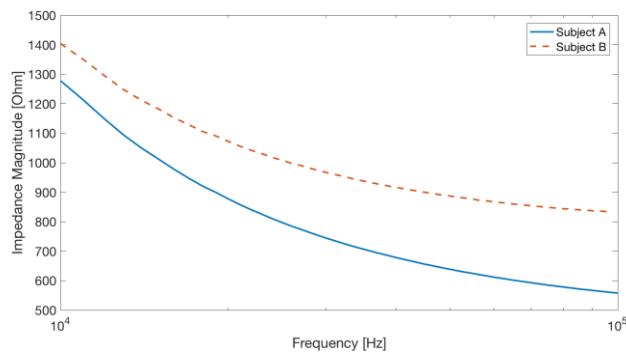

Fig. 8. Impedance magnitude of subjects A and B recorded using the AD5933 device.

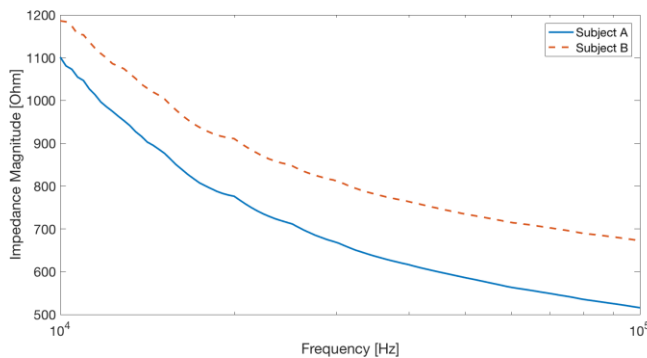

Figure 9. Impedance magnitude of subjects A and B recorded using the HP4194 device.

The phase data shown in figures 10 and 11, are also consistent between AD and HP devices. The differences between the data of AD and HP devices are due to differences in the measurement setups. This difference could potentially be compensated by carefully adjusting cable size, length, and separation distance so that both devices have the identical conditions. However, for our study, this correction was deemed unnecessary, as we were interested in differences between subjects as consistent measurements were conducted among samples. Therefore, the below representative data suggests that AD device can capture

differences in arm impedance when the subjects have different body mass index and body fat.

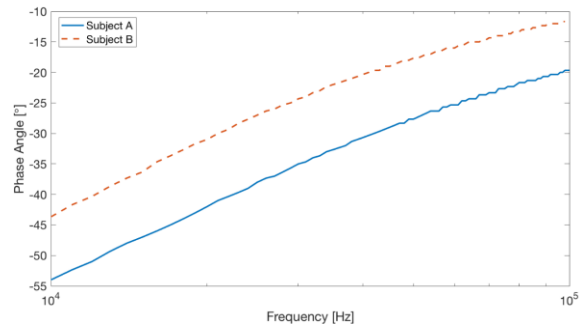

Figure 10. Impedance phase of subject A and B recorded using the AD5933 device.

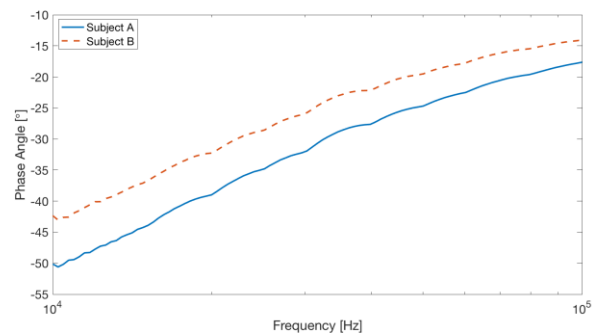

Fig. 11. Impedance phase of subjects A and B recorded using the HP4194 device.

## 6. CONCLUSIONS

For bioelectric impedance analysis applications such as those performed in this human study, the AD5933 Impedance Converter chip recorded similar measurements to the HP4194A Precision Impedance Analyzer that was used as the control device. This suggests that the AD5933 can be used effectively in commercial products aimed at these biomedical applications. Future work for this project entails completing the data analysis on all seventy study participants.

## 7. REFERENCES

- [1] AnalogDevices.2005. *1MSPS, 12-Bit Impedance Converter, Network Analyzer*. AD5933 technical datasheet. Analog Devices, Norwood, MA.
- [2] Analog Devices. *AD5933 Evaluation Board Software Rev. B*. Technical Software Interface. Analog Devices, Norwood, MA.
- [3] Analog Devices. 2005. *Evaluating the AD5933 1 MSPS, 12-Bit Impedance Converter Network Analyzer EVAL-AD5933EBZ* technical datasheet. Analog Devices, Norwood, MA.

[4] Paul Horowitz and Winfield Hill. 2016. *The Art of Electronics*, New York, NY: Cambridge University Press.

[5] Keysight Technologies. *Agilent 4194A Precision Impedance Analyzer 4194A* technical datasheet. Keysight Technologies, Santa Rosa, CA.

[6] Keysight Technologies. — *Impedance Measurement Handbook, A guide to measurement technology and techniques, 6th Edition*. Application Note. Keysight Technologies, Santa Rosa, CA.

[7] Miguel Usach. 2013 *How to Configure the AD5933/5934* Appl. Note AN-1252 for AD5933/5934. Analog Devices, Norwood, MA.

[8] Texas Instruments. 2013. *Low-Cost, Integrated Analog Front-End for Weight-Scale and Body Composition Measurement AFE4300* technical datasheet. Texas Instruments, Dallas, TX.

## 8. ACKNOWLEDGEMENTS

This research was supported by the Engaged Learning program at Southern Methodist University and mentored by Dr. Ahmet Can Sabuncu. This work was part of the Lyle School of Engineering's Senior Design course and the project as a whole would not have been possible without teammates Mar McCreary, Danya Hoban, Taylor Barg, and Hyun Song.