

University of New Orleans

ScholarWorks@UNO

University of New Orleans Theses and
Dissertations

Dissertations and Theses

Spring 5-13-2016

The origin and expansion of the eastern red fox

Adrienne Egge Kasprowicz

University of New Orleans, New Orleans, adrienne.egge@gmail.com

Follow this and additional works at: <https://scholarworks.uno.edu/td>



Part of the [Animal Studies Commons](#), [Biodiversity Commons](#), [Evolution Commons](#), [Geographic Information Sciences Commons](#), [Other Ecology and Evolutionary Biology Commons](#), [Population Biology Commons](#), and the [Zoology Commons](#)

Recommended Citation

Kasprowicz, Adrienne Egge, "The origin and expansion of the eastern red fox" (2016). *University of New Orleans Theses and Dissertations*. 2143.

<https://scholarworks.uno.edu/td/2143>

This Dissertation-Restricted is protected by copyright and/or related rights. It has been brought to you by ScholarWorks@UNO with permission from the rights-holder(s). You are free to use this Dissertation-Restricted in any way that is permitted by the copyright and related rights legislation that applies to your use. For other uses you need to obtain permission from the rights-holder(s) directly, unless additional rights are indicated by a Creative Commons license in the record and/or on the work itself.

This Dissertation-Restricted has been accepted for inclusion in University of New Orleans Theses and Dissertations by an authorized administrator of ScholarWorks@UNO. For more information, please contact scholarworks@uno.edu.

The origins and expansion of the eastern red fox (*Vulpes vulpes*)

A Dissertation

Submitted to the Graduate Faculty of the
University of New Orleans
in partial fulfillment of the
requirements for the degree of

Doctor of Philosophy
in
Conservation Biology

by
Adrienne Egge Kasprowicz
B.S. University of Virginia, 2008

May 2016

ACKNOWLEDGEMENTS

I wish to recognize and thank several people without whom this road would have been much more difficult. First and foremost, I'd like to thank my family who have been a source of encouragement, insight, and occasionally manual labor. To Eric, you have helped form the person I have become, and I am infinitely better for it.

I would also like to thank my committee member, Dr. Ben Sacks, and his entire lab, especially Dr. Mark Statham. Thank you for giving me your insight, experience, lab space, significant edits, and most of all your patience.

There would not have been samples to analyze if not for all of the trappers and wildlife officials who contributed to this study, especially C. Bernier of the Vermont Department of Fish and Wildlife and Scott Smith at the New York Department of Environmental Conservation, and TrapperMan.com.

Thank you to the members of my committee, each of whom has ensured a well-rounded education in conservation. Dr. Howard taught me ecology, behavior, and an infinite pool of fun animal facts. Dr. Anthony introduced the techniques of population genetics and theories of conservation management, the foundations for a conservationist. Dr. Bell completely changed my attitude and understanding of phylogenetics and systematics which made me fearless towards other fields that seemed daunting before.

Finally, I would like to thank my advisor, Dr. Steven Johnson who gave me the freedom to fail but never allowed me to quit. I know I am a bolder and more able researcher because of you.

Table of Contents

List of Figures	v
List of Tables	vi
Abstract	vii
Chapter One – Introduction	1
Invasive species	2
Population growth and expansion	3
Introductions and invasions	4
Natural range expansion	4
Hybridization and admixture	5
Molecular markers	6
Red foxes in North America	9
Research goals and questions	11
Literature Cited	13
Chapter Two – Fate of the other redcoat: remnants of colonial British foxes in the Eastern United States	19
Abstract	20
Introduction	21
Materials and Methods	24
Study area and sample collection	24
Data Analyses	27
Results	30
Origins of eastern red fox lineages	30
Geographic patterns	33
Discussion	39
Acknowledgements	43
Literature Cited	44
Appendix	48
Chapter Three – History of the native red fox in the eastern United States: identifying the impacts of spatial expansion and translocation on the structure of a mobile generalist	49
Abstract	50
Introduction	51
Methods	54
Sample Collection and markers	54
Population differentiation	56
Expansion	58
Impact of the Appalachian Mountain Range	58
Landscape Resistance	59
Results	59
Summary Statistics	59
Population Structure	60
Expansion	67

Resistance surface models	67
Discussion	69
Expansion and Admixture.....	70
The Appalachian Mountains	71
Conclusions	75
Acknowledgements	75
Literature cited	76
Appendix	80
Chapter Four – The extent of European introgression in native red fox populations based on nuclear markers	81
Introduction	82
Methods	84
Sampling	84
Genotyping.....	85
Population statistics	85
Source of nuclear genome.....	86
Introduced admixture.....	86
Results.....	87
Summary statistics	87
Genetic structure and differentiation	88
Discussion	94
Literature Cited	97
Chapter Five – Conclusions	100
Literature Cited	108
Appendix.....	110
Vita	113

List of Figures

Figure 2.1 Map of the study area and locations of red fox samples	25
Figure 2.2 Maximum likelihood tree of 697-bp concatenated cytochrome- <i>b</i> and control-region sequences from red foxes of the Eastern United States	30
Figure 2.3 Median-joining network of 19 haplotypes composed of microsatellite loci linked on the Y chromosome	33
Figure 2.4 Geographic distribution of mitochondrial haplotypes of 569 modern red foxes (top left) and 14 historically sampled red foxes (top right) Lower left: Median-joining network of 697-bp mitochondrial sequences	37
Figure 3.1 Map of sample locations in study area	55
Figure 3.2 Graphs of $\ln P(D)$ and ΔK	61
Figure 3.3 Bar plots from Structure analysis for $K = 2 - 10$ with and without location priors	62
Figure 3.4 Colored SAMOVA table	63
Figure 3.5 Principal Coordinates Analysis of individuals by population	66
Figure 3.6 Graphs of relationship between genetic distance and geographic distance and allelic richness versus Euclidean distance from VT	68
Figure 3.7 Graph of genetic distance versus resistance distance	69
Figure 3.8 Bar plot of microsatellite population assignment and mitochondrial haplotype assignment.....	74
Figure 4.1 Bar plot of population assignment with source populations at $K = 2$ and $K = 3$	90
Figure 4.2 Graphs of $\ln P(D)$ and ΔK	92
Figure 4.3 Bar plots of cluster assignments from Structure based on $K = 4 - 7$	93

List of Tables

Table 2.1 Distribution of mitochondrial haplotypes across modern and historical sampling locations	31
Table 2.2 Haplotype diversity and distribution of Y-chromosome haplotypes	35
Table 2.3 Indices of genetic diversity based on mtDNA in sample locations	36
Table 2.4 Results of SAMOVA based on $K = 1 - 6$	38
Table 2.5 Pairwise population comparisons using Φ_{ST} and F_{ST}	38
Table 3.1 Summary statistics of μ_{sat} diversity across sampling locations	60
Table 3.2 Results of AMOVA's based on <i>a priori</i> information	64
Table 3.3 Pairwise genetic distance between locations based on Nei's D_A and F_{ST}	65
Table 4.1 Population statistics for pooled sample locations and source locations	88
Table 4.2 Pairwise population comparisons between pooled sample locations and source locations	88
Table 4.3 Pairwise population comparisons between individual sample locations and source locations.....	89
Table 4.4 Results of AMOVA's based on <i>a priori</i> hypotheses	91
Table 4.5 Number of hybrid individuals in each sample location including sources	94

ABSTRACT

When new populations are first identified in a region there are multiple potential sources: introduction of a non-native species, extra-range expansion of a nearby population, or demographic growth of a previously unnoticed species. Red foxes were absent or rare in the mid-eastern portion United States until the late 1800s. Their origins potentially include natural population increase/expansion, translocations from Europe, and, eventually, 20th century fur farming. In this study I attempt to identify the relative impact of native expansion versus human mediated introductions of both colonial era European foxes and early 20th century fur-farm foxes on the establishment of red foxes in the mid-Atlantic region of the United States. I subsequently address the potential impacts of hybridization and nuclear introgression between previously separate sister taxa. Through analysis of mitochondrial DNA, I identified indigenous haplotypes, two European haplotypes, and fur-farm haplotypes; another set of haplotypes were potentially indigenous or native. In addition, I found European Y-chromosome haplotypes. Most European and fur-farm haplotypes were found near the densely human-populated coastal plain and Hudson River lowlands; most red foxes of the Appalachians and Piedmont had native eastern haplotypes. However, nuclear data does not support this division showing low genetic structure despite the broad geographic scale of our study area, attributable both to range expansion and admixture. Admixture has not had the same impact on the nuclear genome as it has in mitochondrial haplotypes leading to mito-nuclear discordance across the region. I also found evidence for differential patterns of expansion related to habitat. Specifically, the Appalachian Mountains acted as a corridor for gene flow from the northern native source into the southern Mid-Atlantic region.

Keywords: *Vulpes vulpes*, invasive species, population genetics, expansion, introgression

Chapter 1

Dissertation Introduction

Invasive species

Humans have affected the environment in various ways. Among the most impactful of these is the redistribution of species. Species that have spread into novel environments either from an introduction site or a nearby habitat are considered “invasive alien species” (IAS) and can severely threaten native flora and fauna (Richardson et al 2011). The establishment of these species is cited as a leading cause of biodiversity decline (Genton et al 2005; Ricciardi 2007; Kirk et al 2011; LeRoux et al 2011). In addition, a 2005 study estimated IAS cause \$120 billion in annual losses in the United States (Pimental et al 2005). Though this estimate could be considered spurious and does not include the benefits of certain IAS (i.e. European honeybees), it demonstrates the magnitude of the impact (Pejar and Mooney, 2009). In addition to transcontinental introductions, humans have affected the distribution of native species through habitat conversion resulting in range expansions. Spatial expansion is the extension of a population into an area that was previously uninhabited by that population. Expansions can occur naturally along an environmental gradient or follow the artificial introductions of individuals into new habitats (Estoup et al 2004). For some species, particularly vertebrates, successful range expansion is strongly associated with humans (Sakei et al 2001).

Although biological invasions and expansions are not uniquely caused by humans, modern rates of each are several orders of magnitude greater than prehistoric rates (Allendorf and Lundquist 2003; Ricciardi 2007; Wilson et al 2009; Richardson et al 2011). Whereas historical invasions are the result of infrequent, long-distance dispersal, human globalization has increased frequency and effectively decreased the difficulty imposed by long distance dispersal. International commerce has facilitated the spread and distribution of millions of individuals worldwide (Wilson et al 2009; Genovesi et al 2015). This can be intentional for economic

purposes or unintentional such as through ballast water in marine transport. The result is the buildup of invasive potential that can increase the likelihood of an introduction turning into an invasion. European colonization of the Americas brought with it massive changes in the land, which in turn altered the relative abundances and community composition of species (Pimm et al 1995).

New populations of species, whether they are from introductions or natural expansions, can significantly impact the evolutionary pathway of native species through competitive exclusion, niche displacement, hybridization, introgression, predation, and extinction (Mooney and Cleland 2001). While the unprecedented rate of invasion poses threats to native biota, it also creates opportunities to study ecological and evolutionary theories (Allendorf and Lundquist 2003). Molecular analyses of IAS allow researchers to understand mechanisms of growth and population dynamics (Richardson et al 2011). We can study the relationship between genetic diversity at onset of introductions versus performance. In addition, we can examine molecular evolution in the face of hybridization. Finally, comparing introduction histories and success can yield biogeographical insights important for understanding impacts of climate change (LeRoux et al 2011; Moran and Alexander 2014).

Population growth and expansion

When populations expand, either from a source population or from introduced colonies, they face genetic bottlenecks because a limited sampling of the population is relocating (Allendorf and Lundquist 2003). This, in turn, is expected to create patches of lower diversity. However, low diversity is rarely a characteristic of successful invaders (Parker et al 2013). Strict spatial expansion of native populations can similarly leave a distinct signature on genetic

structure (Ray et al 2003, Excoffier 2004). These consequences vary from the creation of sectors of lower genetic diversity to high frequency of random alleles due to genetic surfing (Excoffier et al 2009). Both carry different genetic signatures that make it possible to distinguish between them.

In successful invaders, reduced genetic variability due to low heterozygosity is often overcome by repeat introductions from different source populations (Sakei et al 2001; Kowarik 2003; Allendorf and Lundquist 2003; Le Roux et al 2011). This can often times cause higher diversity in newly founded populations than in the source populations and strong differentiation if independent introductions occur across a landscape. Newly founded populations with higher genetic diversity are less likely to go extinct because they are more able to evolve adaptive traits necessary to survive in the new environment (Agash et al 2011). Furthermore, bottlenecks can purge deleterious recessive alleles thus reducing inbreeding depression (Moran and Alexander 2014). Invasive populations also benefit from low population density allowing for exponential growth. The effects of drift and selection are likely to vary between colonies and while long-distance dispersal events across the landscape can facilitate gene flow between colonies, strong differentiation between colonies with high heterozygosity and gene diversity is expected.

Natural range expansions most often occur in a stepwise pattern with genetic differentiation increasing from the source (Schrey et al 2014). The result then is a series of founder effects along the expansion front and reduction in average heterozygosity (Slatkin and Excoffier 2012). Genetic drift in these colonies reduces overall allelic diversity along the axis of the expansion front, but also increases the frequency of some rare alleles, a process dubbed ‘gene surfing’ (Excoffier and Ray 2008; Hallatschek and Nelson 2008). Essentially, alleles on the fringe of the range disperse beyond it as the leading edge of the expansion. The low population

size allows genetic drift to drive some alleles that were rare in the original population to high frequencies. Reduced intraspecific competition from low population density then allows these few individuals to increase exponentially, also increasing the frequencies of those alleles. When colonization is the result of long distance dispersal events, gene surfing can cause increasing genetic differentiation of populations along the expansion front from the source population (Hallatschek and Nelson 2008). The result is still clinal variation with increasing differentiation from the source population. While strong gene flow between the colonies can erase some of the differentiation, reduced gene flow to and from the source population will maintain discrete differentiation between the source and new portion of the range (Hagen et al 2015; Norén et al 2015).

Hybridization and admixture

As populations expand and previously isolated lineages come into contact with one another, hybridization and admixture can occur. This type of genetic restructuring can have positive and negative effects. The extinction of native genotypes and disruption of local adaptations can limit a species ability to thrive in its habitat or tolerate environmental shifts. If the introduced population is the result of human breeding, it may introduce traits that were bred for anthropogenic existence and be detrimental in the wild (Kidd et al 2009; Dierking et al 2014). Indeed, human induced hybridizations have contributed to the decline and extinction of many plant and animal species (Kovach et al 2015). Additionally, the global redistribution of species and subsequent admixture of genes continues the homogenization of Earth's biota.

However, hybridization and admixture can benefit populations. The introduction of new alleles can increase overall diversity of a population. These alleles could also be beneficial for

the existing population. Hybridization may contribute to speciation by creating new hybrid taxa, or promoting adaptive divergence thereby facilitating speciation (Abbott et al 2013). It is also important to consider the extent to which hybridization and introgression occurs naturally. It is estimated 10-30% of multicellular plant and animal species regularly hybridize (Mallet, 2005). The impacts of hybridization and subsequent admixture are varied and investigation into the degree to which sister taxa do interbreed furthers our evolutionary understanding and provides insights for management.

Molecular markers

Because range expansion and non-native introductions can generate distinct geographic patterns of genetic diversity, use of multiple genetic markers can help to differentiate these demographic processes (Hagen et al 2015; Norén et al 2015). Additionally, advances in population genetics now allow better resolution of taxonomic issues, elucidate geographic origins of invaders, track dispersal, and detect admixture (Kirk et al 2011). Furthermore, improvements in technology result in more efficient and cheaper techniques (Geraldes et al 2008; Peres-Espona et al 2010; Chang et al 2011; Sastre et al 2011). It is particularly important when studying populations that are either recently derived or have a likelihood of admixture to perform a comprehensive, multiple gene analysis that includes mitochondrial and nuclear loci (Geraldes et al 2008).

Mitochondrial DNA has been used for determining historical patterns of population structure and population origins since Avise and Ellis (1986) introduced it as a molecular marker. Since then it has revolutionized phylogeography by allowing examination of intraspecific genealogies (Avise et al 1989). Mitochondrial DNA has several characteristics

which makes it ideal for phylogenetic analysis. First, it rapidly evolves through base substitutions making it easy to track changes through lineages (Avise et al 1989). Despite its rapid evolution it is highly conserved in size, content and arrangement allowing inter and intraspecific comparison (Avise and Ellis, 1986). Mitochondrial DNA is maternally inherited meaning it is effectively haploid, non-recombining, and can trace a single maternal lineage (Avise and Ellis, 1986; Avise et al 1987). Several successful phylogenetic studies have been performed on red foxes using mitochondrial DNA. The two markers most frequently used are the cytochrome b gene and the D-loop control region (Fрати et al 1998; Inoue et al 2007; Aubry et al 2009, Statham et al 2012, 2014; Teacher et al 2011)). Given their nearly global distribution red foxes provide an interesting model for phylogeographic analysis. .

The Y-chromosome is somewhat unexplored in population studies outside of model organisms. This is because it can be very difficult to isolate markers (Petit et al 2002; Greminger et al 2010). However, it has the potential to be as significant in population studies as mitochondrial DNA. The mammalian non-recombining Y region (NRY) on the Y-chromosome is analogous to mtDNA in that is present as a single copy within the cell and lacks recombination (Greminger et al 2010). While this creates a potentially useful marker for studying paternal lineages, there are several road blocks limiting its' use. During analysis, Y-markers tend to have lower genetic diversity because they are haploid and have a smaller expected effective population size (Wandeler and Camensich 2011). Mutation rates are higher than in the rest of the genome because of the accumulation or replication errors during gametogenesis (Greminger et al 2010). Higher mutation rates mean that the Y-chromosome is faster evolving and since it does not recombine it provides a paternal measure of gene flow (Clare 2011). In most mammalian species, males are the dispersing sex therefore mtDNA does not give a

comprehensive view of demographic history. Since the focus of this project is on the recent history of red foxes in North America, Y-chromosomal data is expected to be more informative than mitochondrial data.

Several types of markers can be isolated from the Y-chromosome including single nucleotide polymorphisms (SNPs) and microsatellite repeat motifs. Each of these markers can give different information regarding population histories. However, microsatellites are better for identifying intra-species variation and Y-microsatellites can be incorporated to existing genotyping for autosomal microsatellites (Wandeler and Camensich 2011). While these markers may be more difficult to isolate than their autosomal counterparts, fewer are necessary to describe paternal genetic diversity (Greminger et al 2010). For example, only two diagnostics SNPs were necessary to show the extent of admixture between two subspecies of rabbits (Geraldès et al 2008).

The most popular marker for population genetics analyses are microsatellites because they are multi-allelic, co-dominant, abundant, reproducible, have a characteristic mutational behavior, and can be used in high-throughput genotyping (Kelkar et al 2010; Guichoux et al 2011). Traditionally microsatellites have been used to study contemporary admixture but because of recombination it is difficult to use them to look at historical admixture. Microsatellites are still a popular marker in population analyses and are useful for looking at current gene flow (Kelkar et al 2010). They promote detection of low levels of introgression and recent temporal resolution (Perez-Espona et al 2010).

Red Foxes in North America

In North America there are at least nine subspecies of *Vulpes vulpes*, eight of which are endemic: *V.v. alascensis*, *V.v. abietorum*, *V.v. regalis*, *V.v. rubricosa*, *V.v. macroura*, *V.v. cascadenis*, *V.v. necator*, and *V.v. patwin* (Churcher 1959; Aubry 1983; Kamler & Ballard 2002, Aubry et al 2009, Sacks et al 2010). *Vulpes v. macrura*, *cascadenis* and *necator* are found in the western mountains of the United States, namely the Rocky, Cascade, and Sierra Nevada Mountains, respectively (Aubry 1983, Kamler and Ballard 2002). The Sacramento Valley red fox, *V.v.patwin*, was recently identified as distinct (Sacks, 2010). The remaining four are found in the boreal forests of Alaska and Canada with *V.v rubricosa* found in Central and Eastern Canada (Kamler and Ballard, 2002).

Red foxes initially colonized North America during the Illinoian Glaciation via the Bering Land Bridge between 300,000 and 100,000 years before present. They expanded during the Sangamon interglacial period throughout the western United States and Canada but were isolated during the Wisconsin glacial period (Aubry et al 2009). At the time of European colonization red foxes were primarily a boreo-montane species found in the western mountains of the United States, in Alaska, and in Central and Eastern Canada (Churcher, 1959; Kamler and Ballard, 2002; Aubry et al 2009; Statham et al 2012). They were believed to occur above 40-45°N latitude and were “scarce or absent from the unbroken mixed hardwood” where grey foxes occurred (Churcher, 1959). However, discoveries of late-Holocene faunal sites along the Appalachian Mountains suggest red foxes existed south of this point prior to European colonization (Statham et al 2012). Subsequently, red foxes either disappeared or remained scarce and undetected (Frey 2013).

The spread of agriculture and habitat change coincided with the appearance of red foxes south of Pennsylvania (Audubon and Bachman 1849; Rhodes 1908; Churcher 1959). The changing habitat allowed the red fox to partially displace the native grey fox in the southern portion of the continent (Churcher 1959). Concurrently, red foxes were reported to have been introduced into the colonies from Europe for sport hunting with the earliest introductions into New York, Pennsylvania and Virginia in the mid-18th century from Scandinavia, France, and Great Britain. (Kamler and Ballard 2002). They were said to have been introduced specifically due to the paucity of natural populations (Churcher 1959). From then on it was assumed that the red foxes now seen in the former southern colonies were European in origin, or at the most “a mongrel species” (Rhoads, 1903). However, the sources of these reports were second hand hearsay with no scientific evidence supporting the claim (Frey 2013).

Beginning in the 19th century red fox populations appeared in central and western states such that by the 1920’s red foxes were present in Texas, Oklahoma, Kansas and Nebraska. This expansion continued until red foxes reached California towards the end of the twentieth century (Kamler and Ballard, 2002). Prior to this range expansion, red foxes from the East were being transported to California, Washington, and areas of the Midwest through the fur farm trade (Aubry, 1983; Lewis et al 1999; Statham et al 2012). As is common with fur farms, individuals escaped from captivity and formed feral populations (Aubry, 1983; Lewis et al 1999; Zalewski et al 2011; Statham et al 2012). Currently red foxes are prevalent throughout the United States and most of Canada.

Given the reports of red foxes in the east as descendants of introduced European red foxes, and the documented expansion throughout the central and western United States, it is not surprising the red fox was designated an “invasive species”. The first attempt at determining the

source of the Eastern red fox was by Churcher in 1959. He performed a comprehensive morphological analysis of red foxes from Europe, Asia, Alaska and Eastern Canada and determined they were the same species. Since his samples were from Eastern Canada, in the historically native range of North American red foxes, this did not address the status of the south-eastern red fox. More recently, a study by Statham et al (2012) sampled individuals from Georgia, West Virginia, Arkansas, North Carolina, Oklahoma, and Texas and found no evidence of European matrilineal ancestry, refuting the claim that red foxes in the United States are European invasives. However, their study did not include a thorough sampling of the mid-Atlantic region which was the primary region for introductions. Thus, the status of the Eastern red fox remains unknown.

Goals and Questions

The global decline in biodiversity has numerous causes, invasive species being among the most severe with significant resources spent on managing their impacts (Genovesi et al 2015). However, the establishment of new populations or species is not exclusively attributable to introductions and invasions. Range expansions of nearby native species reflect healthy biotic functioning, a necessary feature in a time of rapid climate change (Hewitt 2000). For the sake of scientific resource management, it behooves researchers to differentiate between potentially harmful invasive populations and naturally established native ones, something which can be difficult for cryptic or interbreeding species (Devillard et al 2014).

Even if invasive species are introduced, this does not guarantee their success (Parker et al 2013). Typically, a successful invasion requires multiple introductions from multiple source populations over an extended period of time (Wilson et al 2009).

Specifically, the questions addressed in the framework of this dissertation are:

1. What are the origins of the red fox in eastern United States?
2. What is the geographic extent of introduced European foxes?
3. Has native range expansion or human-mediated introduction played a bigger part in the establishment of red foxes in eastern United States?
4. How has the landscape, specifically the Appalachian Mountain Range, impacted the distribution of red foxes in eastern United States?
5. What is the extent of nuclear introgression from British red foxes?

My dissertation uses multiple molecular approaches to answering these questions in three chapters. In the second chapter I identify the origins of red foxes in different regions throughout eastern United States. I use mitochondrial markers and Y-chromosome markers to trace maternal and paternal lineages and incorporate historical and international samples to identify the sources. Chapter three focuses on the connectivity red foxes in eastern North America. I use population genetics to discriminate between natural range expansion and human mediated population growth as the cause of red fox persistence in the region. Additionally, I incorporate resistance modeling and landscape genetics to explore the impacts of the Appalachian Mountains on dispersal and distribution. In chapter four I explore the degree of influence introduced red foxes have had on the nuclear genome and the level of introgression that has occurred. Finally, in chapter five I address all of the questions in light of the results and acceptance of the hypothesis that red foxes in eastern United States are native.

LITERATURE CITED

- ABBOTT, R., ALBACH, D., ANSELL, S., ARNTZEN, J. W., BAIRD, S. J. E., BIERNE, N., BOUGHMAN, J., BRELSFORD, A., BUERKLE, C. A., BUGGS, R., BUTLIN, R. K., DIECKMANN, U., EROUKHMANOFF, F., GRILL, A., CAHAN, S. H., HERMANSEN, J. S., HEWITT, G., HUDSON, A. G., JIGGINS, C., JONES, J., KELLER, B., MARCZEWSKI, T., MALLET, J., MARTINEZ-RODRIGUEZ, P., MÖST, M., MULLEN, S., NICHOLS, R., NOLTE, A. W., PARISOD, C., PFENNIG, K., RICE, A. M., RITCHIE, M. G., SEIFERT, B., SMADJA, C. M., STELKENS, R., SZYMURA, J. M., VÄINÖLÄ, R., WOLF, J. B. W. AND D. ZINNER. 2013. Hybridization and speciation. *Journal of Evolutionary Biology*, 26: 229–246.
- AGASH, D., FALK, J.J., AND D.I. BOLNICK. 2011. Effects of founding genetic variation on adaptation to a novel resource. *Evolution*, 65: 2481-2491.
- ALLENDDORF, F.W. AND L. L. LUNDQUIST. 2003. Population biology, evolution, and control of invasive species. *Conservation Biology*, 17: 24-30.
- AUBRY, K.B. 1983. The cascade red fox: distribution, morphology, zoogeography and ecology. Ph.D. dissertation. University of Washington, Seattle.
- AUBRY, K. B., M. J. STATHAM, B. N. SACKS, J. D. PERRINE, AND S. M. WISELY. 2009. Phylogeography of the North American red fox: vicariance in Pleistocene forest refugia. *Molecular Ecology* 18: 2668–86.
- AUDUBON, J. J., AND J. BACHMAN. 1849. The viviparous quadrupeds of North America. Privately published by J.J. Audubon, New York. Vol. 2.
- AVISE, J.C, ARNOLD, J., BALL, M., BERMINGHAM, E., LAMB, T., NEIGEL, J.E., REEB, C. A., AND N.C. SAUNDERS. 1987. Intraspecific Phylogeography: Mitochondrial DNA bridge between population genetics and systematics. *Annual Review of Ecology and Systematics*, 18: 489–522.
- AVISE, J.C. AND D. ELLIS. 1986. Mitochondrial DNA and the evolutionary genetics of higher animals. *Philosophical Transactions of the Royal Society B*, 312: 325–342.
- AVISE, J.C. 1989. Gene trees and organismal histories: A phylogenetic approach to population biology. *Evolution*, 43: 1192-1208.
- CHANG, S.-W., OSHIDA, T., ENDO, H., NGUYEN, S. T., DANG, C. N., NGUYEN, D. X., JIANG, X., LI, Z.-J. AND L.-K. LIN. 2011, Ancient hybridization and underestimated species diversity in Asian striped squirrels (genus *Tamiops*): inference from paternal, maternal and biparental markers. *Journal of Zoology*, 285: 128–138.
- CHURCHER, C. S., 1959. The Specific Status of the New World Red Fox. *Journal of Mammology* 4:513–520.

- CLARE, E.L. 2011. Cryptic species? Patterns of maternal and paternal gene flow in eight neotropical bats. *PLoS ONE*, 6: e21460
- DEVILLARD, S., T. JOMBART, F. LÉGER, D. PONTIER., L. SAY, AND S. RUETTE. 2014. How reliable are morphological and anatomical characters to distinguish European wildcats, domestic cats and their hybrids in France? *Journal of Zoological Systematics and Evolutionary Research*, 52:154–162.
- DIERKING, J., PHELPS, L., PRÆBEL, K., RAMM, G., PRIGGE, E., BORCHERDING, J., BRUNKE, M. AND C. EIZAGUIRRE. 2014. Anthropogenic hybridization between endangered migratory and commercially harvested stationary whitefish taxa (*Coregonus* spp.). *Evolutionary Applications*, 7: 1068–1083.
- ESTOUP, A., BEAUMONT, M., SENNEDOT, F., MORITZ, C. AND J.-M. CORNUET. 2004. Genetic analysis of complex demographic scenarios: spatially expanding populations of the Cane toad, *Bufo marinus*. *Evolution*, 58: 2021–2036.
- EXCOFFIER, L. 2004. Patterns of DNA sequence diversity and genetic structure after a range expansion: lessons from the infinite-island model. *Molecular Ecology*, 13: 853-864.
- EXCOFFIER, L AND N. RAY. 2008. Surfing during population expansions promotes genetic revolutions and structuration. *Ecology and Evolution*, 23: 347-351.
- EXCOFFIER, L., HOFER, R. AND M. FOLL. 2009. Detecting loci under selection in a hierarchically structured population. *Heredity*, 103: 285-298.
- F. FRATI, G.B. HARTL, S. LOVARI, M. DELIBES AND G. MARKOV. 1998. Quaternary radiation and genetic structure of the red fox *Vulpes vulpes* in the Mediterranean Basin, as revealed by allozymes and mitochondrial DNA. *Journal of Zoology*, 245, pp 43-51.
- FREY, J. K. 2013. Re-evaluation of the evidence for the importation of red foxes from Europe to colonial America: Origins of the southeastern red fox (*Vulpes vulpes fulva*). *Biological Conservation* 158:74-79.
- GENOVESI, P., CARBONERAS, C., VILÁ, M., AND P. WALTON. 2015. EU adopts innovative legislation on invasive species: a step towards a global response to biological invasions? *Biological Invasions*, 17:1307-1311.
- GENTON, B. J., J. A. SHYKOFF, AND T. GIRAUD. 2005. High genetic diversity in French invasive populations of common ragweed, *Ambrosia artemisiifolia*, as a result of multiple sources of introduction. *Molecular Ecology*, 14:4275-4285.
- GERALDES, A., BASSET, P., GIBSON, B., SMITH, K., L., HARR B., YU, H.-T., BULATOVA, N., ZIV, Y. AND M.W. NACHMAN. 2008. Inferring the history of speciation in house mice from autosomal, X-linked, Y-linked and mitochondrial genes. *Molecular Ecology*, 17: 5349–5363.

- GREMINGER, M.P., KRÜTZEN, M., SCHELLING, C., PIENKOWSKA-SCHELLING, A. AND P. WANDELER. 2010. The quest for Y-chromosomal markers – methodological strategies for mammalian non-model organisms. *Molecular Ecology Resources*, 10: 409–420.
- GUICHOUX, E., LAGACHE, L., WAGNER, S., CHAUMEIL, P., LÉGER, P., LEPAIS, O., AND R.J. PETIT. 2011. Current trends in microsatellite genotyping. *Molecular Ecology Resources*, 11: 591-611.
- HAGEN, S.B., KOPATZ, A., ASPI, J., KOJOLA, I., AND H. G. EIKEN. 2015. Evidence of rapid change in genetic structure and diversity during range expansion in a recovering large terrestrial carnivore. *Proceedings of the Royal Society B – Biol Sci*, 282
- HALLATSCHICK, O. AND D. NELSON. 2008. Gene surfing in expanding populations. *Theoretical Population Biology*, 73: 158-170.
- HEWITT, G. 2000. The genetic legacy of the Quaternary Ages. *Nature*, 405: 907-913.
- INOUE, T., NONAKA, N., MIZUNO, A., MORISHIMA, Y., SATO, H., KATAKURA, K., AND Y. OKU. 2007. Mitochondrial DNA phylogeography of the red fox (*Vulpes vulpes*) in northern Japan. *Zoological science*, 24: 1178-1186.
- KAMLER, J. F., AND W. B. BALLARD. 2002. A review of native and nonnative red foxes in America. *Wildlife Society Bulletin*, 30:370–379.
- KELKAR, Y. D., STRUBCZEWSKI, N., HILE, S. E., CHIAROMONTE, F., ECKERT, K. A., AND K.D. MAKOVA. 2010. What is a microsatellite: a computational and experimental definition based upon repeat mutational behavior at A/T and GT/AC repeats. *Genome Biology and Evolution*, 2: 620-635
- KIDD, A. G., J. BOWMAN, D. LESBARRERES, AND A. I. SCHULTE-HOSTEDDE. 2009. Hybridization between escaped domestic and wild American mink (*Neovison vison*). *Molecular Ecology*, 18:1175-1186.
- KIRK, H., J. PAUL, J. STRAKA, AND J. R. FREELAND. 2011. Long-distance dispersal and high genetic diversity are implicated in the invasive spread of the common reed, *Phragmites australis* (Poaceae) in northeastern North America. *American Journal of Botany*, 98:1180-1190.
- KOVACH, R. P., MUHLFELD, C. C., BOYER, M. C., LOWE, W. H., ALLENDORF, F. W., AND G. LUIKART. 2015. Dispersal and selection mediate hybridization between a native and invasive species. *Proceedings of the Royal Society of London B: Biological Sciences*, 282: 20142454
- KOWARIK, I. 2003. On the role of alien species in urban flora and vegetation. *Urban Ecol.* 321-338.

- LE ROUX, J. J., G. K. BROWN, M. BYRNE, J. NDLOVU, D. M. RICHARDSON, G. D. THOMPSON, AND J. R. U. WILSON. 2011. Phylogeographic consequences of different introduction histories of invasive Australian *Acacia* species and *Paraserianthes lophantha* (Fabaceae) in South Africa. *Diversity and Distributions*, 17:861-871.
- LEWIS, J.C., SALLEE, K.L. AND R.T. GOLIGHTLY. 1999. Introduction and range expansion of nonnative red foxes (*Vulpes vulpes*) in California. *The American Midland Naturalist*, 142(2): 372-381.
- MALLET, J. 2005. Hybridization as an invasion of the genome. *Trends in Ecology & Evolution*, 20: 229-237.
- MOONEY, H. A. AND E. E. CLELAND. 2001. The evolutionary impact of invasive species. *Proceedings of the National Academy of Sciences*, 98: 5446-5451.
- MORAN, E. V., AND J. M. ALEXANDER. 2014. Evolutionary responses to global change: lessons from invasive species. *Ecology Letters*, 17: 637-649.
- NORÉN, K., STATHAM, M.J., ÅGREN, E.O., ISOMURSU, M., FLAGSTAD, Ø., EIDE, N.E., BERG, T.B.G., BECH-SANDERHOFF, L. AND B.N. SACKS. 2015. Genetic footprints reveal geographic patterns of expansion in Fennoscandian red foxes. *Global Change Biology*, 21: 3299-3312.
- PARKER, J. D., TORCHIN, M. E., HUFBAUER, R. A., LEMOINE, N. P., ALBA, C., BLUMENTHAL, D. M., BOSSDORF O., et al 2013. Do invasive species perform better in their new ranges? *Ecology* 94: 985-994.
- PÉREZ-ESPONA, S., F. J. PÉREZ-BARBERÍA, C. D. JIGGINS, I. J. GORDON, AND J. M. PEMBERTON. 2010. Variable extent of sex-biased dispersal in a strongly polygynous mammal. *Molecular Ecology*, 15: 3101-3113.
- PETIT, E., BALLOUX, F. AND L. EXCOFFIER. 2002. Mammalian population genetics: why not Y? *Trends in Ecology & Evolution*, 17: 28-33.
- PIMENTEL, D., ZUNIGA, R. AND D. MORRISON. 2005. Update on the environmental and economic costs associated with alien-invasive species in the United States. *Ecological Economics* 52: 273-288.
- PIMM, S.L., RUSSELL, G. J., GITTLEMAN, J.L. AND T. M. BROOKS. 1995. The future of biodiversity. *Science*, 269: 347-350.
- RAY, N., CURRAT, M. AND L. EXCOFFIER. 2003. Intra-deme molecular diversity in spatially expanding populations. *Molecular Biology and Evolution*, 20: 76-86.

- RHODES, S.N. 1908. The mammals of Pennsylvania and New Jersey. Privately Published, Philadelphia.
- RICCIARDI, A. 2007. Are modern biological invasions an unprecedented form of global change? *Conservation Biology*, 21:329-336.
- RICHARDSON, D. M., AND M. REJMÁNEK. 2011. Trees and shrubs as invasive alien species—a global review. *Diversity and Distributions*, 17: 788-809.
- SACKS, B. N., M. J. STATHAM, J. D. PERRINE, S. M. WISELY, AND K. B. AUBRY. 2010. North American montane red foxes: expansion, fragmentation, and the origin of the Sacramento Valley red fox. *Conservation Genetics*, 11:1523–1539.
- SAKAI, A. K., ALLENDORF, F. W., HOLT, J. S., LODGE, D. M., MOLOFSKY, J., WITH, K. A. AND D.E. MCCAULEY. 2001. The population biology of invasive species. *Annu Rev Ecol Syst*, 305-332.
- SASTRE, N., VILÀ, C., SALINAS, M., BOLOGOV, V. V., URIOS, V., SÁNCHEZ, A., FRANCINO, O. AND O. RAMÍREZ. 2011. Signatures of demographic bottlenecks in European wolf populations. *Conservation Genetics*, 12: 701-712.
- SCHREY, A. W., LIEBL, A. L., RICHARDS, C. L., AND L.B. MARTIN. 2014. Range expansion of house sparrows (*Passer domesticus*) in Kenya: evidence of genetic admixture and human-mediated dispersal. *Journal of Heredity*, 105: 60-69.
- SLATKIN, M., AND L. EXCOFFIER. 2012. Serial founder effects during range expansion: a spatial analog of genetic drift. *Genetics* 191: 171-181.
- STATHAM, M. J., B. N. SACKS, K. B. AUBRY, J. D. PERRINE, AND S. M. WISELY. 2012. The origin of recently established red fox populations in the United States: translocations or natural range expansions? *Journal of Mammalogy*, 93:52–65.
- STATHAM, M. J., J. MURDOCH, J. JANECKA, K. B. AUBRY, C. EDWARDS, C. D. SOULSBURY, O. BERRY, Z. WANG, D. HARRISON, M. PEARCH, L. TOMSETT, J. CHUPASKO, AND B. N. SACKS. 2014. Range-wide multilocus phylogeography of the red fox reveals ancient continental divergence, minimal genomic exchange and distinct demographic histories. *Molecular Ecology*, 23:4813-4830.
- TEACHER, A. G., THOMAS, J. A. AND I. BARNES. 2011. Modern and ancient red fox (*Vulpes vulpes*) in Europe show an unusual lack of geographical and temporal structuring, and differing responses within the carnivores to historical climatic change. *BMC evolutionary biology*, 11: 214.
- WANDELER, P. AND G. CAMENISCH. 2011. Identifying Y-chromosomal diversity by long-template PCR. *Molecular Ecology Resources*, 11:835-841.

ZALEWSKI, A., MICHALSKA-PARDA, A., RATKIEWICZ, M., KOZAKIEWICZ, M., BARTOSZEWICZ, M., AND M. BRZEZIŃSKI. 2011. High mitochondrial DNA diversity of an introduced alien carnivore: comparison of feral and ranch American mink *Neovison vison* in Poland. *Diversity and Distributions*, 17: 757-768.

WILSON, R.J., DAVIES, Z.G. AND C. D. THOMAS. 2009. Modelling the effect of habitat fragmentation on range expansion in a butterfly. *Proceedings of the Royal Society of London B: Biological Sciences*, 276: 1421-1427.

Chapter 2

Fate of the other red coat: remnants of colonial British foxes in the Eastern United States

Published

Kasprowicz, A. E., Statham, M. J., & Sacks, B. N. (2016). Fate of the other redcoat: remnants of colonial British foxes in the Eastern United States. *Journal of Mammalogy*, 97(1), 298-309.

ABSTRACT

Red foxes were absent or rare in the southeastern United States until the late 1800s. Their origins potentially include natural population increase/expansion, translocations from Europe, and, eventually, 20th century fur farming. Previous studies have found no European haplotypes in North America, but few samples were sourced from the Atlantic coastal plain, closer to the source of putative introductions. Through analysis of mitochondrial DNA in 584 red foxes from this region, we identified indigenous haplotypes in $\geq 35\%$ of foxes, one of two European haplotypes in 17% of foxes, and fur-farm haplotypes in $\geq 13\%$ of foxes; another 35% of foxes had haplotypes potentially indigenous or native. In contrast, only 3 of 135 (2%) male foxes carried a single European Y-chromosome haplotype. Most European and fur-farm haplotypes were found near the densely human-populated coastal plain and Hudson River lowlands; most red foxes of the Appalachians and Piedmont had native eastern haplotypes. Our findings suggest that the more remote, upland populations primarily reflect indigenous red fox matriline, whereas urban-associated populations in and around the mid-Atlantic coastal plain and Hudson lowlands reflect an admixture of native and nonnative maternal sources. Autosomal markers are needed to further elucidate the extent of European and fur-farm introgression in the Appalachians and further west.

Keywords:

Eastern United States, European red fox, mitochondrial DNA, phylogeography, population genetics, red fox, *Vulpes fulva*, *V. vulpes*, Y chromosome

INTRODUCTION

Humans affect the distributions of species in a variety of ways, ranging from direct translocations between continents to conversion of habitats, which, in turn, can facilitate range expansions of native species. The establishment of nonnative species from intercontinental translocations is typically harmful to native communities and has been cited as a leading cause of biodiversity decline (Genton et al 2005; Ricciardi 2007; Kirk et al 2011; LeRoux et al 2011). In contrast, range expansions of native species, even if prompted by anthropogenic landscape changes, can reflect a healthy level of biotic functioning, which is necessary for the resilience of native communities in the face of changing climates and environments (Hewitt 2000; Valladares et al 2014; Gimona et al 2015). Differentiating between these sources of origins of recently established species is therefore important and not always obvious, such as when distinctions between different species are morphologically cryptic or when native and nonnative species can interbreed (Devillard et al 2014).

Red foxes (*Vulpes* spp.) in the eastern United States represent such a case where origins remain unclear. Early naturalists believed that red foxes did not occur south of New York State at the time of European colonization (Audubon and Bachman 1849; Churcher 1959). Subsequent discoveries of late-Holocene faunal sites along the Appalachians and adjacent Piedmont as far south as Georgia, however, suggest that red foxes occurred in these areas prior to European colonization, after which time they either disappeared or remained scarce and undetected (Statham et al 2012; Frey 2013). It is possible that the range extent of the red fox along the Appalachians (and further north) was dynamic during the late Holocene, e.g., depending on climatic fluctuations, and/or that clearing of forests for agriculture encouraged population increase or expansion of native red fox populations in the Atlantic coastal plain (Churcher 1959).

Today, red foxes are abundant throughout the Appalachians and eastward continuously to the coast. In addition to uncertainty about the pre-European range and early range expansions of native red fox, the origins and composition of these modern eastern red foxes are obscured by putative introductions of foxes from Europe in the 1800s to coastal regions, such as Delaware or New Jersey (Kamler and Ballard 2002; Frey 2013). Complicating the issue further, fox farms composed of individuals derived ultimately from eastern Canadian and Alaskan populations, but selectively bred in captivity, proliferated throughout North America in the early to mid-1900s, providing yet a third potential source (Statham et al 2011, 2012). We refer to these farm-derived foxes as “feral” to indicate their derivation from captive-bred stock (Sacks et al 2011). Understanding the contribution of European ancestry to contemporary populations is particularly important in light of recent evidence for species-level divergence between Eurasian and North American red foxes (Statham et al 2014), but the potential contribution of fur-farm foxes to contemporary wild populations also has implications for their characterization as a natural or anthropogenic population (Sacks et al 2011). For example, interbreeding with escaped mink from fur farms has been identified as a threat to the viability of wild mink in eastern Canada (Kidd et al 2009).

Hypotheses for the ancestral composition of contemporary eastern red foxes have spanned the extremes. One review concluded that all modern red foxes in the eastern United States, as well as in the Midwest and Canada, were of European ancestry (Kamler and Ballard 2002). Conversely, a subsequent review suggested the possibility that European red foxes were never imported to the continent in the first place (Frey 2013). More consistent with the latter hypothesis, prior to our study, mitochondrial sequences from many red foxes from throughout the United States and Canada had yet to include a single European haplotype (e.g., Perrine et al

2007; Aubry et al 2009; Sacks et al 2010; Statham et al 2012, 2014; Langille et al 2014).

However, only a small number of red foxes from the eastern United States had been sequenced and most of these were from the Appalachians and vicinity, where origination by natural means was most likely (Statham et al 2012; Frey 2013). In particular, the distribution of late-Holocene faunal remains suggest that red foxes occurred naturally, if episodically, within what Merriam (1898) termed the “Transition zone,” corresponding primarily to the Appalachian Mountains, and the “upper Austral zone,” corresponding primarily to the Piedmont (Frey 2013). Therefore, it remains possible that eastern red foxes in lowest-elevation regions, such as the Atlantic coastal plain, contain European ancestry (Aubry et al 2009; Statham et al 2012). Secondly, 1 of 3 red foxes sequenced from the coastal plain contained an Alaskan haplotype known to be associated with fur farming, indicating at least some contribution of fur farm stock to modern eastern red foxes (Statham et al 2012).

We sought to resolve the origins of red foxes in the eastern United States through analysis of matrilineal and patrilineal markers of 584 individuals collected from several eastern states (Fig. 1). Specifically, we investigated 1) the extent to which red foxes in eastern United States reflected European versus North American ancestry, and 2) the extent to which North American ancestry reflected natural populations versus escape or release of captive-reared fur-farm foxes. We also investigated population genetic structure with particular attention to whether the populations in the Appalachian and less human-dominated adjacent regions were distinct from those of the more densely human-dominated coastal plain and Hudson River lowlands (hereafter Hudson lowlands). We sequenced mitochondrial DNA and genotyped 2 microsatellite loci from the Y chromosome, and compared these to published sequences and genotypes from throughout the global range of the red fox to assess continental origins. The use

of maternally and paternally inherited markers also enabled us to directly assess interbreeding between European and North American ancestors and male versus female introgression.

MATERIALS AND METHODS

Study area and sample collection.

The study area encompassed a combination of less human-dominated natural areas associated with the Appalachians and Piedmont and high human-density regions of the Atlantic coastal plain, particularly along the “I-95 corridor” linking New York and Washington D.C., and Hudson lowlands (Fig. 1).

We collected a total of 584 tissue samples during 2010–2013, which are currently archived in the sample collection at the Mammalian Ecology and Conservation Unit at the University of California at Davis. Most samples were contributed by trappers in the form of muscle tissue samples (~2 g preserved in 95% ethanol; $n = 69$) or dried skin snips ($n = 498$), but we also collected muscle samples from 17 carcasses discovered opportunistically (e.g., road kills). Samples were collected from Vermont ($n = 26$), New York ($n = 138$), New Jersey ($n = 66$), Pennsylvania ($n = 120$), Delaware ($n = 48$), Maryland ($n = 105$), Virginia ($n = 79$), and North Carolina ($n = 2$). Additionally, we included 17 previously published mtDNA sequences, including 2 collected in New York State in 1856 (before the advent of fur-farming) and 12 collected from Georgia ($n = 9$, 1931–1933), West Virginia ($n = 1$, 1938), and Maine ($n = 2$, 1923), also less likely than modern samples to contain fur-farm ancestry, and 3 modern samples collected from coastal North Carolina (Statham et al 2012). We grouped samples into geographically proximate clusters or, where sparse, mapped individual samples (Fig. 1).

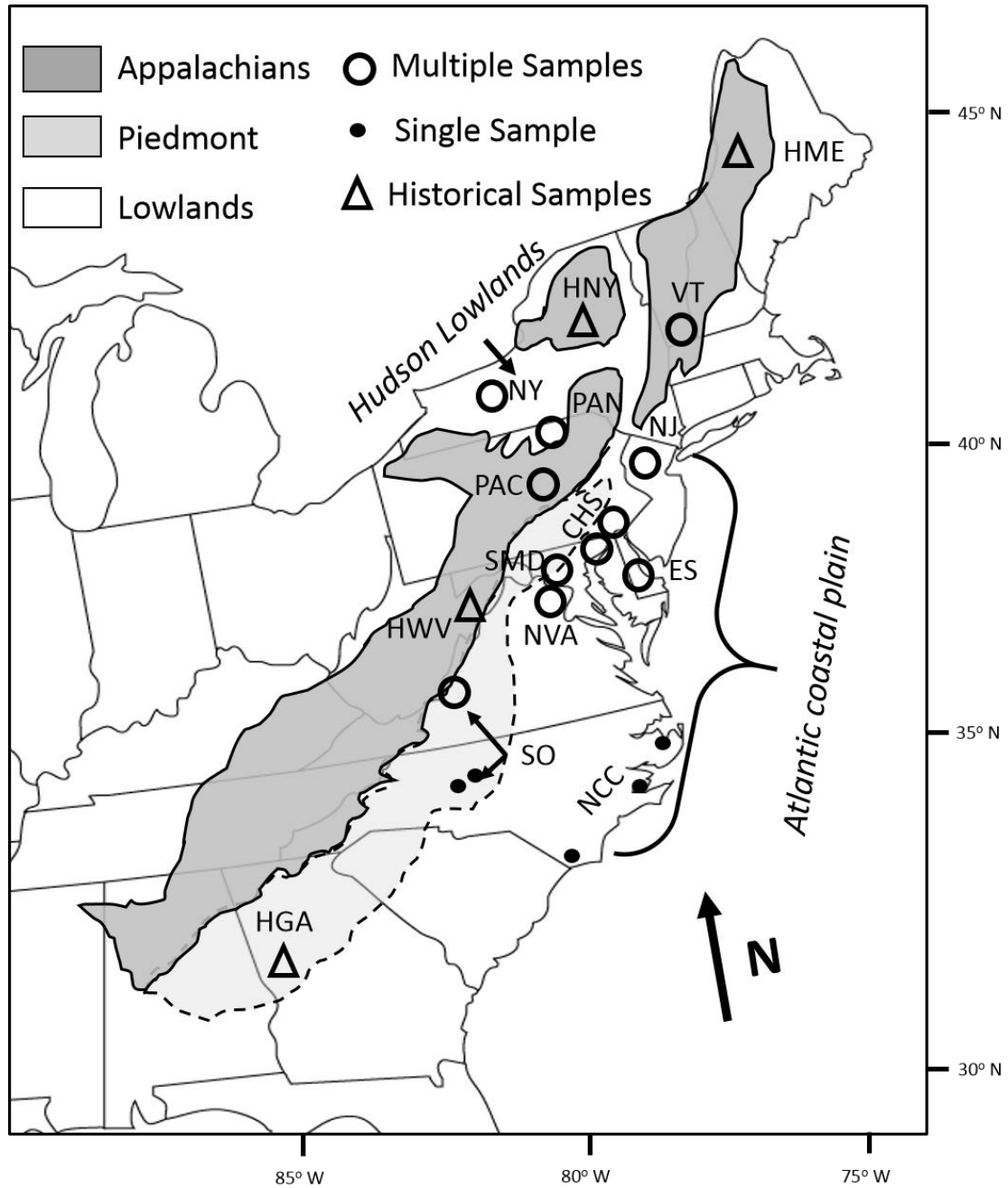

Figure 1: Map of the study area and locations of red fox samples collected during 2010–2013, along with four sites of previously published historical (1856–1938) samples from the Appalachian (dark grey) and Piedmont (light grey) regions (Statham et al 2012). Sampling locations are abbreviated as Eastern Shore (ES), Chesapeake (CHS), North Pennsylvania (PAN), Central Pennsylvania (PAC), New Jersey (NJ), New York (NY), Southern Virginia and western North Carolina Piedmont (SO), Northern Virginia (NVA), Southern Maryland (SMD), Vermont (VT), Historical Maine (HME), Historical New York (HNY), Historical West Virginia (HWV), Historical Georgia (HGA), and coastal North Carolina (NCC). The samples for the present study emphasized the more densely human-dominated lowland regions of the mid-Atlantic coastal plain and Hudson lowlands portion of New York State.

We extracted DNA from tissue using a DNeasy Blood and Tissue Kit (Qiagen, Inc., Valencia, California) following manufacturers recommendations. We amplified and sequenced 697 base-pairs (bp) of mitochondrial DNA including 354 bp of the cytochrome-*b* (*Cytb*) gene using primers RF14724 and RF15149 and a 343 bp of the control region using the primers VVDL1 and VVDL6 that were previously analyzed in > 1,000 samples from throughout the worldwide range of the red fox (Perrine et al 2007; Aubry et al 2009; Statham et al 2012, 2014). We conducted polymerase chain reaction (PCR) in 25 µl reactions under the following conditions: 1 µl template DNA, 0.5 µM of forward and reverse primer, and One *Taq* 2X master mix used according to manufacturer's instructions (Applied Biosystems, Foster City, California). The thermocycler profile included an initial denaturation step at 94°C for 30 s, 30 cycles at 94°C for 30 s, 45°C for 60 s, and 68°C for 60 s, and a final extension step at 68°C for 5 min. We sequenced cleaned PCR product from both forward and reverse primers of both fragments using BigDye Terminator Cycle Sequencing Ready Reaction Kit v 3.1 (Applied Biosystems), cleaned sequences using ExoSAP-IT (Affymetrix, San Diego, California), and electrophoresed them with an Applied Biosystems 3130XL capillary sequencer.

We PCR-amplified 2 Y-chromosome markers that produced haplotypes directly comparable to previous ones typed in European, Asian, and North American foxes (Statham et al 2014). We used the primers reported in Statham et al (2014): Y29-Fox (F2: AGTGCTTAGGCTCAGGATGC, R1: TCCAGGTTTTATTTAGGGTCTT) and Y30-Fox (F2: TCCTTTCCATTTTCAGAAAGC; Y30_Dog R: AGAGAGGTAAGGCATAGTTTG). We fluorescently labeled forward primers of both loci with 6-FAM on the 5' end. These loci were amplified together in a single 10 µl reaction using a Qiagen Multiplex kit with Q-solution according to manufacturer's instructions (Qiagen, Inc.) with an annealing temperature of 60°C.

We electrophoresed PCR products using an ABI 3730 capillary sequencer (Applied Biosystems) and scored alleles relative to an internal size standard, Genescan 500 LIZ (Applied Biosystems), using STRand software (Toonen and Hughes 2001).

Data analyses

To address our first objective, characterizing matriline and patriline as to their continental origins, we compared mtDNA and Y-chromosome haplotypes from this study to published ones and evaluated origins based on both identity and phylogenetic clustering. The mitochondrial haplotypes could be unambiguously assigned to North America or Europe (Aubry et al 2009; Statham et al 2014). Although the Y-chromosome haplotypes were based on only two microsatellite loci, continental differences, possibly related to indels in the flanking regions, rendered these loci used in tandem also to be diagnostic. In particular, locus Y30 was monomorphic in North America (387 bp) and distinct from the size range over most of Europe (393–405 bp); the exception was in Scandinavia (as with Asia), where some haplotypes also had the 387 bp allele at this locus. However, in such cases, the other locus (Y29) had alleles ranging 156 to 166 in Eurasia and 170 to 178 in North America (Statham et al 2014). Therefore, our basic approach was to construct phylogenetic trees and networks consisting of the haplotypes in this study and representative reference haplotypes.

For mitochondrial data, we read, aligned, and edited sequences in Geneious v6.0 (Drummond et al 2014). We concatenated *Cytb* and control-region fragments into composite mtDNA haplotypes for analysis because no recombination occurs on the mtDNA genome. For novel sequences, we used the Basic Local Alignment Search Tool (BLAST) to search the nucleotide database in GenBank (Benson et al 2013). We follow the naming conventions of

previous studies (e.g., Statham et al 2014), whereby the name of the *Cytb* fragment (beginning with or consisting of a letter) is followed by a dash and then the control-region fragment (a number); Y-chromosome haplotypes are named based on the fragment size of the two microsatellite loci. For mitochondrial data, we estimated maximum likelihood (ML) trees with nodes assessed from 1,000 bootstrapped trees in Paup* v. 4 (Swofford 2003). We used JModelTest to determine the best-fit model of evolution for each gene (Darriba et al 2012) and used Akaike information criterion (AIC) to select the model most compatible with PAUP* v. 4. We only used one individual per haplotype per population from the study sample, along with all previously published haplotypes from North America and a subset from Europe, that encompassed all haplotypes from Britain, Ireland, Sweden, Norway, and countries of Central Europe (Statham et al 2014), all areas putatively sourcing introductions of red fox to North America (Kamler and Ballard, 2002; Long 2003; Statham et al 2012; Frey 2013). We visualized the tree in FigTree (Rambaut and Drummond 2012). To test alternative phylogenetic hypotheses, we ran an approximately unbiased (AU) test using PAUP*v.4.0 (Shimodaira 2002; Swofford 2003).

To explore the phylogenetic affinities of the Y-chromosome markers we combined alleles from the two linked loci into haplotypes and compared these to a global dataset to assess continental origins (Statham et al 2014). Specifically, we added our new haplotypes to a haplotype network initially created using Network 6.0 (Bandelt et al 1999) on which haplotypes were previously clustered into exclusively North American or Eurasian haplogroups (Statham et al 2014).

To address the contributions of fur-farm ancestry in our study area, we relied on two indicator haplotypes, G-38 and N-7, that were ultimately derived from, and rare in, Alaskan red

fox populations (Aubry et al 2009) but are common in fur farms and “feral” populations (i.e., populations derived from fur farms) throughout the United States (Perrine et al 2007; Sacks et al 2010, 2011; Statham et al 2011, 2012). Other common fur-farm haplotypes were derived from eastern Canada and were therefore potentially the same ones that could have colonized the eastern U.S. naturally (Statham et al 2012). Therefore, we considered eastern Canadian haplotypes previously associated with fur farm ancestry to be of ambiguous origin. The only previous study to use the Y-chromosome markers did not include fur-farm derived or sufficient numbers of native North American foxes to enable us to differentiate paternal ancestry within the continent.

Our final objective was to explore geographic patterns of haplotype distribution to assess the possibility of differentiation among populations corresponding to different historical origins. We estimated haplotype diversity (h) for both mtDNA and Y-chromosome haplotypes and nucleotide diversity (π), Tajima's D , and Fu's F_s for mtDNA in Arlequin v3.5 (Fu 1997, Tajima 1989, Excoffier Lischer 2010). We visualized haplotype relationships using a haplotype network created with Network 6.0 and bases corresponding to the *Cytb* portion weighted twice that of the control-region bases (Sacks et al 2010). To assess isolation by distance, we performed a Mantel test in Arlequin (Excoffier and Lischer, 2010). We then used a spatial analysis of molecular variance (SAMOVA) in the program SAMOVA 2.0 to identify patterns of hierarchical structure corresponding to $K = 2 - 6$ groupings among 10 spatial units on the basis of pairwise distance among sequences (Dupanloup et al 2002).

RESULTS

Origins of eastern red fox lineages

We successfully amplified both the *Cytb* and control-region mitochondrial DNA fragments in 566 individuals. Despite the large number of samples from an extensive region, we identified only 15 distinct haplotypes. Of these, all but one, A-269 (GenBank Accession No. KP860297), had been previously described. However, these haplotypes reflected multiple phylogenetically distinct lineages associated with divergent origins (Fig. 2). The Shimodaira AU test supported previous analyses indicating distinct “Nearctic” and “Holarctic” clades, with a North American subclade (H III Alaskan—Statham et al 2014) nested within the otherwise Eurasian Holarctic clade (Appendix 1).

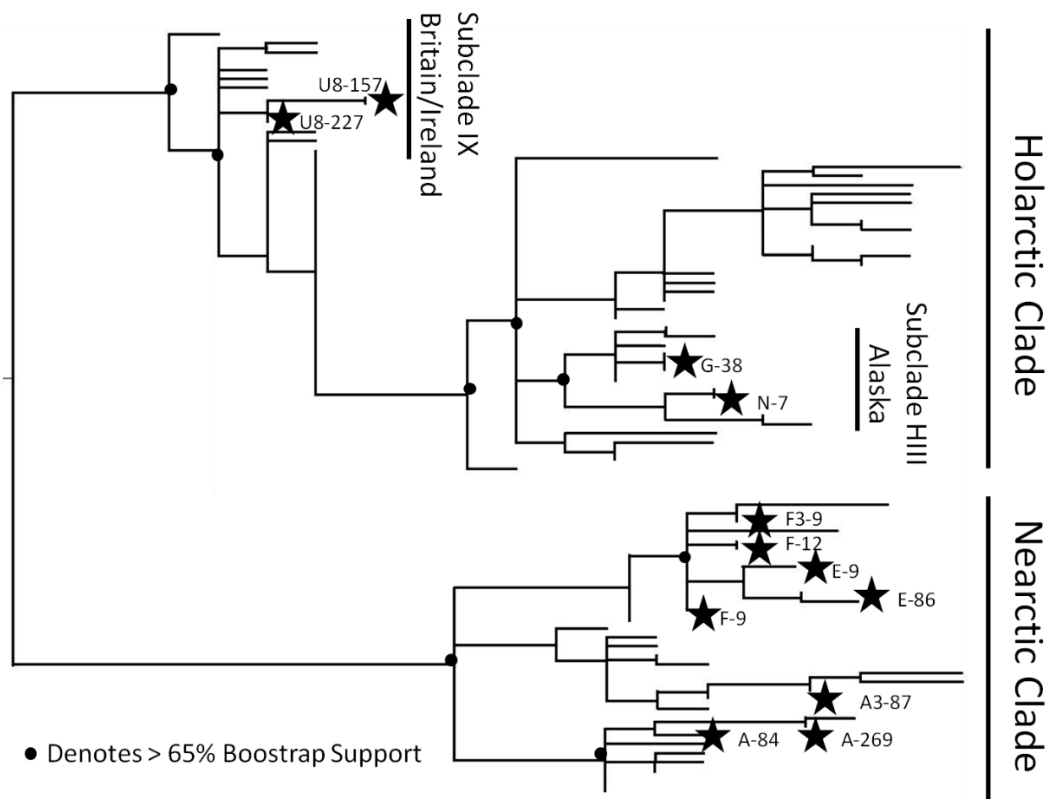

Fig 2. Maximum likelihood tree of 697-bp concatenated cytochrome-*b* and control-region sequences from red foxes of the Eastern United States (starred), shown in relation to previously published sequences from the Holarctic and Nearctic red fox clades (Statham et al 2014). The tree was created under an HKY+I model with 1,000 bootstrap replicates. Some branches of European haplotypes within the Holarctic clade were removed for clarity.

Table 1 Distribution of 15 mitochondrial haplotypes among 583 red foxes from 18 modern and 4 historical sampling locations, including indigenous eastern haplotypes not previously associated with fur farms (native) or also found in fur-farm foxes (ambiguous native), non-indigenous haplotypes associated with fur farms (fur-farm), and non-indigenous haplotypes from Europe. Sampling locations are abbreviated as Eastern Shore (ES), Chesapeake (CHS), North Pennsylvania (PAN), Central Pennsylvania (PAC), New Jersey (NJ), New York (NY), Southern Virginia and western North Carolina Piedmont (SO), Northern Virginia (NVA), Southern Maryland (SMD), Vermont (VT), Historical Maine (HME), Historical New York (HNY), Historical West Virginia (HWV), Historical Georgia (HGA), and coastal North Carolina (NCC). Spatial units refer to samples used in the SAMOVA. Samples in parentheses were excluded from the SAMOVA due to low sample size.

Sampling location ^a	n	Spatial unit	Regions	Native ^b							Ambiguous native ^c				Fur-farm		European	
				A-84	A8-84	A-269	A3-87	F3-9	F4-81	E2-9	E-9	E-86	F-9	F-12	G-38	N-7	U8-157	U8-227
NY1	7	A	Hudson lowlands	--	--	1	--	1	--	--	--	1	2	--	--	--	2	--
NY2	16	A	Hudson lowlands	--	--	1	--	10	--	--	--	3	--	--	--	--	2	--
NY3	15	A	Hudson lowlands	--	--	5	--	1	--	--	2	--	--	1	--	5	1	
NY4	18	A	Hudson lowlands	--	--	7	--	4	--	--	--	3	1	--	1	--	1	1
NY5	51	A	Hudson lowlands	--	--	4	--	6	--	--	7	24	9	--	1	--	--	--
NY6	9	A	Hudson lowlands	--	--	--	--	2	--	--	1	4	1	--	1	--	--	--
NY7	8	A	Hudson lowlands	--	--	--	--	1	--	--	1	5	--	--	--	--	1	--
NJ1	12	B	Atlantic coast plain	--	--	--	--	2	--	--	--	--	--	--	6	--	1	3
NJ2	51	B	Atlantic coast plain	--	--	1	--	11	--	--	1	7	2	--	18	--	2	9
ES	48	C	Atlantic coast plain	--	--	--	--	18	--	--	--	1	--	--	13	--	16	--
CHS1	55	D	Atlantic coast plain	--	--	--	--	25	--	--	--	4	2	--	4	1	18	1
CHS2	40	D	Atlantic coast plain	--	--	--	--	16	--	--	--	2	7	--	2	--	12	1
SMD	50	E	Atlantic coast plain	--	--	3	--	9	--	--	--	--	16	--	4	17	--	1
NVA	74	F	Atlantic coast plain	--	--	3	4	29	--	--	7	--	5	--	4	--	22	--
PAN	7	G	Appalachian	--	--	1	--	--	--	--	--	6	--	--	--	--	--	--
PAC	72	G	Appalachian	--	--	--	--	24	--	--	23	25	--	--	--	--	--	--
VT	26	H	Appalachian	2	--	--	--	--	--	--	9	7	4	2	1	1	--	--
HME	2	H	Appalachian	--	1	--	--	--	--	--	--	--	1	--	--	--	--	--
HNY	2	H	Appalachian	--	--	--	--	--	--	--	2	--	--	--	--	--	--	--
SO	7	I	Piedmont	--	--	--	--	3	--	--	--	--	3	1	--	--	--	--
HGA	9	J	Piedmont	--	--	--	--	5	--	1	--	--	3	--	--	--	--	--
(NCC)	3	--	Atlantic coast plain	--	--	--	--	--	--	--	--	--	2	--	1	--	--	--
(HWV)	1	--	Appalachian	--	--	--	--	--	1	--	--	--	--	--	--	--	--	--
Total	583	--	--	2	1	26	4	167	1	1	53	92	58	3	57	19	82	17

^a Sampling locations refer to the following counties: Allegany (NY1); Livingston (NY2); Monroe (NY3); Wayne (NY4); Ontario (NY5); Yates (NY6); Steuben (NY7); Morris (NJ1), Warren (NJ2); Kent Cty, DE (ES); Cecil Cty, MD (CHS1); Lancaster Cty, PA (CHS2); Montgomery (SMD); Fairfax and Prince William (NVA); Bradford (PAN); Northumberland (PAC); Windham (VT); Tazewell Cty, VA and Davidson Cty, NC (SO); Beaufort, Brunswick, and Dare Ctys, NC (NCC); Oxford (HME, 1923); Essex (HNY, 1856); Pendelton (HWV, 1938); Talbot (HGA, 1920-1935).

^b Two singleton haplotypes in the historical samples differed from the nearest verified haplotypes by C-T or A-G changes consistent with post-mortem degradation. A8-84 was otherwise the same as A-84 and E2-9 was otherwise the same as E-9.

^c The control region portion of haplotype F3-76 and F-76 (i.e., 9) described by Statham et al 2012 (and Langille et al 2014) differed from haplotype 9 by the insertion of an additional A at the end of a poly-A repeat. Because this insertion was recurrent in multiple lineages, we excluded it from analysis, resulting in our subsuming haplotypes F3-76 and F-76 in F3-9 and F-9, respectively.

Most of the haplotypes could be directly assigned to an unambiguous source (Table 1). Previously characterized haplotypes native to eastern Canada and the northeastern United States composed 70% of the sample. However, the subsets of these haplotypes that had not been previously associated with fur farms (A-84, A8-84, A-269, A3-87, F3-9, F4-81, E2-9) and which had been used in fur-farming (E-9, E-86, F-9, F-12) each composed 35% of the total sample. These frequencies imply that 35% to 70% of mtDNA haplotypes arose directly from natural populations. Additionally, two haplotypes derived from Europe (U8-157, U8-227), comprised 17% of the sample. These haplotypes belonged to Holarctic subclade IX which predominates in Great Britain and Ireland, while the specific haplotypes each had been found previously only once, specifically in Ireland (Statham et al 2014). Lastly, 2 haplotypes deriving from Alaskan fur-farm stock (G-38, N-7) composed 13% of the sample. Based on the subset of 377 foxes that carried haplotypes representing unambiguous origins, 54% were native eastern, 26% were European, and 20% were from fur farms.

Out of 135 males that amplified both Y29 and Y30 markers, we observed 5 haplotypes (Table 2). The dominant haplotype, 174/387, composed 83% ($n = 114$) of the total sample and was previously found only in North America (Table 2; Statham et al 2014). We also observed two previously undefined haplotypes that clustered within the North American haplogroup, and a third previously undefined haplotype that clustered within the European haplogroup. Specifically, the European haplotype grouped with others from Great Britain (Fig. 3). In contrast to the mtDNA, only three individuals (2%) carried the European Y-chromosome haplotype; each of these individuals was sampled from a distinct population: Vermont, Central Pennsylvania, and Southern Maryland. Southern Maryland was the only sampling site with both European mtDNA and Y-chromosome haplotypes (one each). Conversely, none of the populations in which

European mitochondrial haplotypes were prevalent had European Y-chromosome markers. In addition, all three males with European Y chromosomes had eastern North American mitochondrial haplotypes.

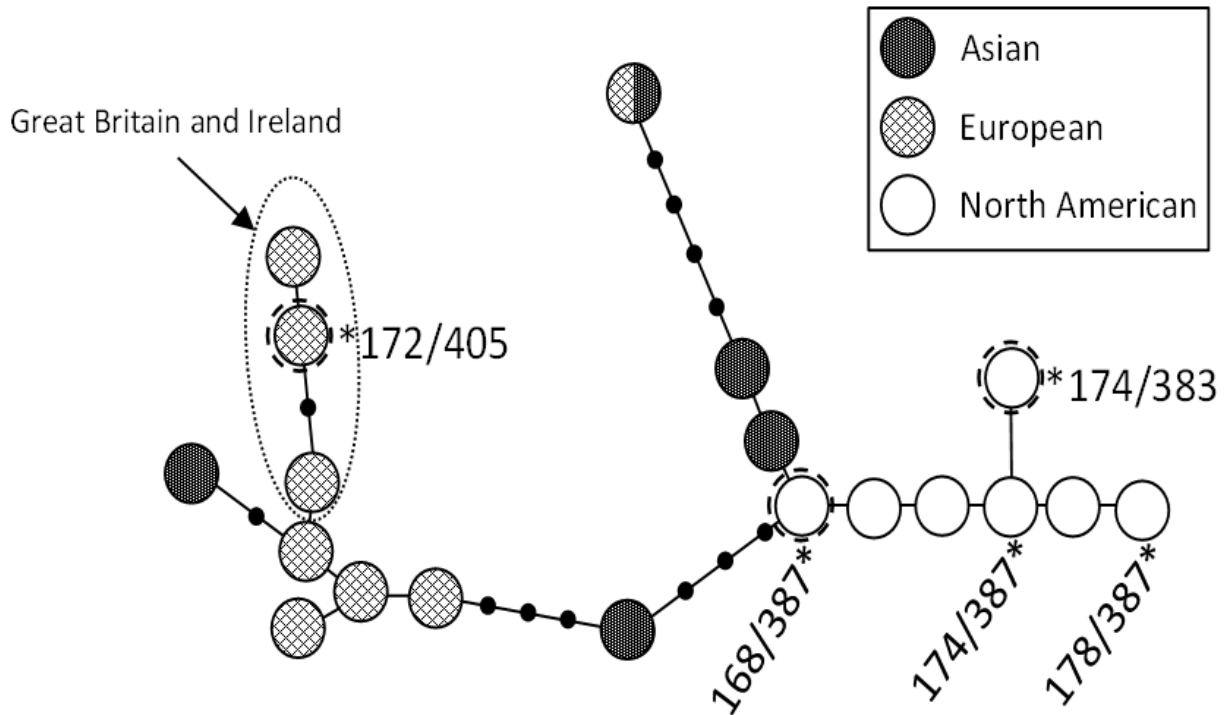

Figure 3. Median-joining network of 19 haplotypes composed of microsatellite loci linked on the Y chromosome, illustrating the phylogenetic placement of the 5 haplotypes found in 133 male red foxes from the Eastern United States relative to 16 previously published haplotypes from red foxes sampled throughout Eurasia and North America (Statham et al 2014). Haplotypes starred and labeled correspond to those found in this study. Three haplotypes newly described in this study are indicated with a dashed ring around the node, and a European haplogroup found previously only in Britain is indicated within the dotted-line ellipse.

Geographic patterns

A total of 99 individuals bearing European mtDNA haplotypes was present in 11 of the 18 samples (Table 1). The haplotype and nucleotide diversities were notably higher in the sites with European ancestry than in those with purely North American ancestry (Table 3). None of the neutrality tests were significant but were generally positive, particularly in sites with European haplotypes. Most of the European haplotypes occurred in the mid-Atlantic states east of the Appalachians but with a relatively small number (13 of 124) occurring also in the Hudson

lowlands of western New York (Fig. 4). Unambiguous fur-farm haplotypes (i.e., those of Alaskan ancestry) were distributed similarly to European ones across sampling locations. Native eastern haplotypes not previously associated with fur farming composed similar portions of all samples. Notably, most (98.4%) of 126 samples from the Appalachians and adjacent Piedmont had haplotypes indigenous to eastern North America (i.e., native or potentially native samples).

We observed no significant relationship between genetic and geographic distance (Mantel test, $r = 0.09$, $P = 0.29$). The SAMOVAs indicated statistically significant divisions corresponding to $K = 2-6$, but Φ_{CT} values did not increase beyond $K = 2$, indicating that a single division into two groups was most parsimonious (Table 4). One group was composed of sites in the mid-Atlantic coastal plain and the other was broadly distributed north to south in or near the Appalachians. Genetic distances among sampling units within these groupings varied but were generally much less than between groups, particularly based on Φ_{CT} , which reflected the sequence divergence and was therefore affected by the high divergence between Nearctic and Holarctic haplotypes (Table 5).

Table 2. Haplotype diversity (h) and distribution of 5 Y-chromosome haplotypes in 133 male red foxes from 16 sampling locations in the Eastern United States.

Sampling location ^a	n	h	Y-chromosome haplotypes				
			174/383	168/387	174/387	178/387	172/405 ^b
NY2	4	0.000	--	--	4	--	--
NY3	7	0.000	--	--	7	--	--
NY4	8	0.125	--	--	7	1	--
NY5	2	0.000	--	--	2	--	--
NY6	3	0.000	--	--	3	--	--
NY7	5	0.000	--	--	5	--	--
NJ1	2	0.500	--	--	1	1	--
NJ2	24	0.121	2	--	21	1	--
ES	8	0.268	--	--	5	3	--
CHS1	4	0.000	--	--	4	--	--
CHS2	10	0.000	--	--	10	--	--
SMD	10	0.289	--	--	8	1	1
NVA	24	0.070	--	--	23	1	--
VT	11	0.264	--	1	9	--	1
PAC	8	0.429	--	--	2	5	1
SO	3	0.000	--	--	3	--	--
Total	133	0.255	2	1	114	13	3

^a Sampling locations refer to the following counties: Livingston (NY2); Monroe (NY3); Wayne (NY4); Ontario (NY5); Yates (NY6); Steuben (NY7); Morris (NJ1), Warren (NJ2); Kent, DE (ES); Cecil, MD (CHS1); Lancaster, PA (CHS2); Montgomery (SMD); Fairfax and Prince William (NVA); Northumberland (PAC); Windham (VT); Tazewell Cty, VA and Davidson Cty, NC (SO).

^bHaplotype 172/405 is presumed to be of European origin.

Table 3. Indices of genetic diversity within spatial red fox sampling units in the Eastern United States: nucleotide diversity (π), haplotype diversity (h), Tajima's D , and Fu's F_s . None of the D or F_s estimates differed significantly from zero ($P < 0.05$).

Spatial Unit ^a	Sampling Locations Included	n	π ($\times 10^{-3}$)	h	Tajima's D	Fu's F_s
VT (H)	VT, HME, HNY	32	7.9	0.766	0.16	4.84
NY (A)	NY1-8	124	11.4	0.813	1.26	12.6
PA (G)	PAC, PAN	79	2.4	0.687	-1.3	1.96
HGA (J)	HGA	9	1.1	0.639	0.19	-0.11
SO (I)	SO	7	1.2	0.714	0.2	-0.24
NJ (B)	NJ1, NJ2	63	15.4	0.772	2.2	12.1
ES (C)	ES	48	16.2	0.689	3.0	19.5
CHS (D)	CHS1, CHS2	95	14.9	0.704	2.9	16.9
NVA (F)	NVA	74	15.5	0.747	1.9	15.5
SMD (E)	SMD	50	12.7	0.754	1.5	11.6

^a Sampling locations refer to standard state abbreviations except for HGA (Historical Georgia), SO (Tazewell Cty, VA and Davidson Cty, NC), ES (Kent Cty, DE), CHS (Cecil Cty, MD and Lancaster Cty, PA), NVA (Fairfax and Prince William Ctys), SMD (Montgomery Cty).

^bHaplotype 172/405 is presumed to be of European origin.

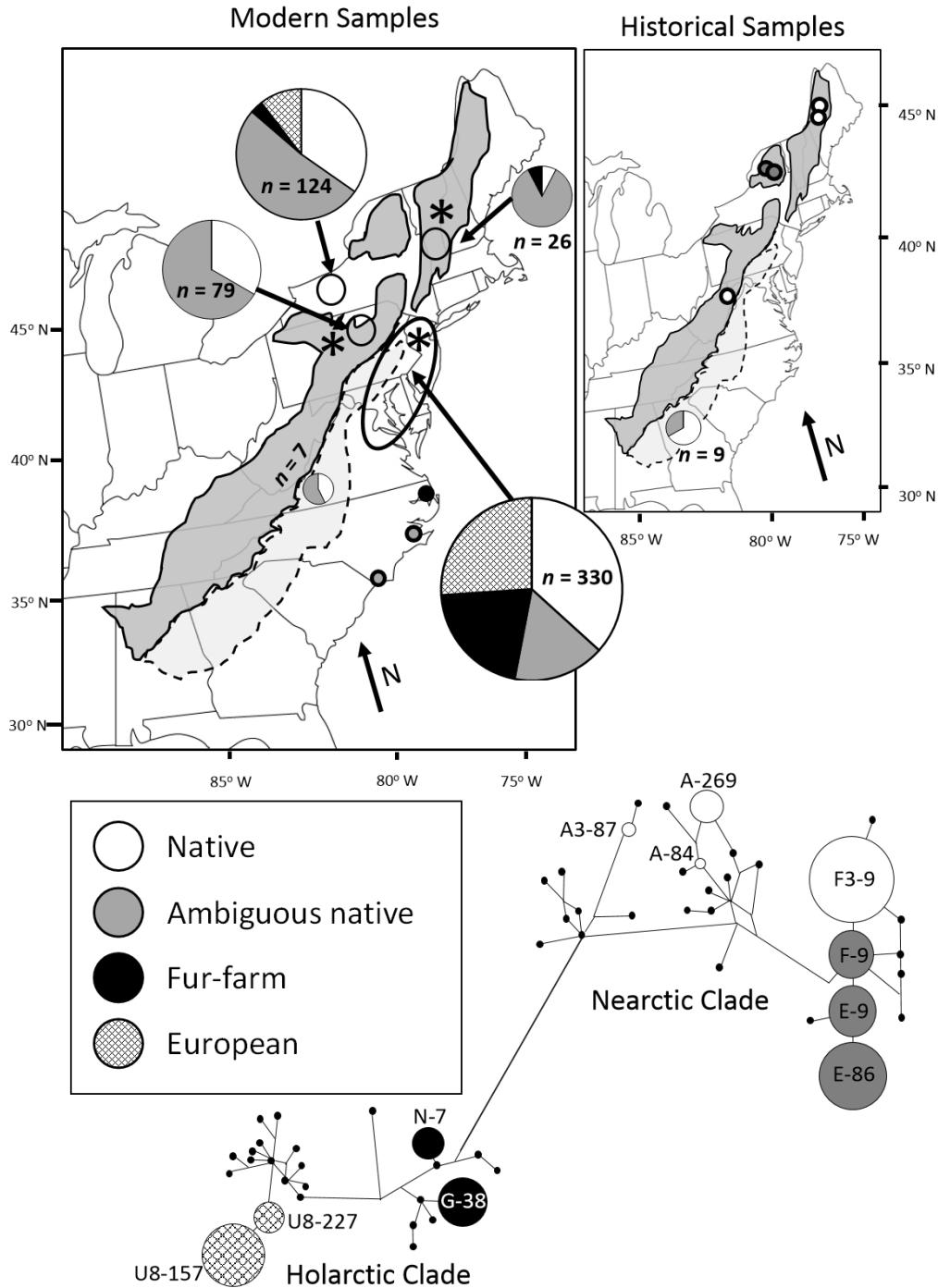

Figure 4: Geographic distribution of mitochondrial haplotypes of 569 modern red foxes (top left) and 14 historically sampled red foxes (top right – Statham et al 2012) coded as to origins (native, ambiguous native/fur farm, fur-farm, or European). Distributions illustrate the localization of European haplotypes (and the majority of fur-farm haplotypes) along the mid-Atlantic coastal plain and, to a lesser extent, the Hudson lowlands portion of New York State, with the Appalachians and Piedmont composed primarily of native or ambiguous native haplotypes. Asterisks (*) indicate sites with a European Y-chromosome haplotype. Lower left: Median-joining network of 697-bp mitochondrial sequences, with circle size proportional to number of individuals in this study and small filled black circles indicating phylogenetic positioning of a subset of previously published haplotypes.

Table 4. Results of SAMOVA analyses on values of $K=1-6$ for red foxes of the Eastern United States. Asterisks indicate statistical significance ($P < 0.05$).

Spatial Unit ^a	$K=2$	$K=3$	$K=4$	$K=5$	$K=6$
VT (H)	A	A	A	A	A
NY (A)	A	A	A	A	A
PA (G)	A	A	A	B	B
HGA (J)	A	A	A	B	C
SO (I)	A	B	A	B	C
NJ (B)	B	C	B	C	D
ES (C)	B	C	B	C	D
CHS (D)	B	C	C	D	E
NVA (F)	B	C	C	D	E
SMD (E)	B	C	D	E	F
ϕ_{ST}	0.25*	0.25*	0.21*	0.20*	0.20*
ϕ_{CT}	0.19*	0.18*	0.18*	0.19*	0.19*

^a Spatial units refer to standard state abbreviations except for HGA (Historical Georgia), SO (Tazewell Cty, VA and Davidson Cty, NC), ES (Kent Cty, DE), CHS (Cecil Cty, MD and Lancaster Cty, PA), NVA (Fairfax and Prince William Ctys), SMD (Montgomery Cty).

Table 5. Pairwise population comparisons for the 10 spatial units^a used in the SAMOVA for red foxes of the Eastern United States. Below the diagonal are ϕ_{ST} values (based on pairwise sequence divergence); above diagonal are conventional (frequency-based) F_{ST} , and in the diagonal are sample sizes. Asterisks indicate statistical significance ($P < 0.05$).

	VT (H)	NY (A)	PA (G)	HGA (J)	SO (I)	NJ (B)	ES (C)	CHS (D)	NVA (F)	SMD (E)
VT (H)	32	0.21*	0.28*	0.28*	0.25*	0.23*	0.28*	0.27*	0.24*	0.24*
NY (A)	0.04*	124	0.25*	0.25*	0.22*	0.21*	0.24*	0.24*	0.22*	0.21*
PA (G)	0.14*	0.12*	79	0.33*	0.30*	0.27*	0.31*	0.30*	0.28*	0.28*
HGA (J)	0.13	0.08*	0.22*	9	0.33*	0.28*	0.33*	0.32*	0.29*	0.29*
SO (I)	0.11*	0.07	0.25*	-0.07	7	0.25*	0.30*	0.29*	0.26*	0.26*
NJ(B)	0.28*	0.26*	0.52*	0.36*	0.35*	63	0.27*	0.26*	0.24*	0.24*
ES (C)	0.29*	0.25*	0.54*	0.34*	0.33*	0.01	48	0.30*	0.28*	0.28*
CHS (D)	0.17*	0.12*	0.34*	0.19*	0.18	0.10*	0.05*	95	0.28*	0.27*
NVA (F)	0.16*	0.09*	0.33*	0.17*	0.16*	0.11*	0.06*	0.00	74	0.25*
SMD (E)	0.18*	0.15*	0.44*	0.25*	0.23*	0.09*	0.10*	0.08*	0.08*	50

^a Spatial units refer to standard state abbreviations except for HGA (Historical Georgia), SO (Tazewell Cty, VA and Davidson Cty, NC), ES (Kent Cty, DE), CHS (Cecil Cty, MD and Lancaster Cty, PA), NVA (Fairfax and Prince William Ctys), SMD (Montgomery Cty).

DISCUSSION

Our study confirmed that European red foxes were introduced to the mid-Atlantic region of North America. Moreover, both mitochondrial and Y-chromosome markers pinpointed the region of origin of these foxes to Britain and Ireland, which was consistent with anecdotal accounts (Frey 2013). The low diversity of maternal and paternal haplotypes in this study was consistent with a single successful introduction of as few as three individuals. The region-wide dispersion of European haplotypes and the sharing of a single Y-chromosome haplotype among three distinct locations further supported a many-generational timeline consistent with colonial origins. The spatial distribution of European mitochondrial haplotypes supported an early anecdotal account that named the Eastern Shore of Maryland as the site of introduction in the late 1700s by English foxes (Frey 2013). We found the highest prevalence of European (i.e., British or Irish) haplotypes on the Eastern Shore, followed closely by the adjacent northern Chesapeake Bay. Thus, taken together, our findings provide the first empirical evidence to substantiate the conventional wisdom that red foxes were introduced from England to the mid-Atlantic region during colonial times.

Given these findings, the next question arising pertains to the spatial extent of European introgression in North American red foxes. Prior to this study, European mitochondrial haplotypes had not been discovered in North America despite sampling and sequencing of many hundreds of foxes (e.g., Statham et al 2014). However, most of the sampling in North America occurred west of the Mississippi River and north of the Hudson River (Aubry et al 2009; Statham et al 2012). Those which had been sampled from the eastern US were concentrated primarily along the Appalachians and adjacent area. In the present study, we sampled no foxes between the Appalachians and Mississippi River, leaving a relatively wide sample gap. Additionally, very few samples were obtained from the southeastern US or from New England. Thus, on the

basis of empirical data alone, European haplotypes could be localized to the small region where we found them in this study, i.e., restricted to portions of a few mid-Atlantic states, or spread over an area as great as the entire eastern seaboard, as bounded by the Mississippi River to the west, the Great Lakes and Saint Lawrence River to the north, and the Gulf of Mexico and Atlantic Ocean to the south and east. To better evaluate these potential scenarios, it is necessary to first elucidate the origins of North American ancestry with respect to indigenous versus feral fur-farm descendants.

It is well supported that prior to the advent of fur-farming in the early 1900s, red foxes were established over much of the mid-Atlantic and southern portions of the east coast (reviewed by Frey 2013). Given that several sampling sites in the present study had no European haplotypes and few to no unambiguous fur-farm haplotypes, our results support Frey's conclusion that these most likely derived from indigenous foxes. Even in the populations with substantial fractions of European and unambiguous fur-farm lineages, these native eastern haplotypes occurred in significant proportions. In particular, the F3-9 haplotype was present in 16/18 sampling locations and composed 82% of samples with haplotypes that had not been previously associated with fur farm ancestry (and 28% of samples overall), suggesting its prominence among an early expansion.

However, it is less clear whether such an expansion would have originated from the north as suggested by early naturalists (e.g., Audubon and Bachman 1849) or from a pre-existing southern population (e.g., Frey 2013). On the one hand, most of the haplotype diversity found in the eastern US in this and previous studies was a subset of that observed in eastern Canadian or fur-farm-derived populations (which themselves originated from eastern Canada; Aubry et al 2009; Statham et al 2012; Langille et al 2014). Only the F3-9 and F4-81 haplotypes were

potentially endemic to the eastern US, one of which differed by a single substitution from a widespread basal Canadian haplotype (F-9); the other haplotype was a singleton. Therefore, we find little evidence to support the presence of a Pleistocene-age eastern US population distinct from eastern Canadian foxes. On the other hand, the widespread nature of the F3-9 haplotype in eastern US samples, including historical Georgia, and its absence in samples north of the Hudson lowlands is consistent with a late Holocene or historical population expansion from somewhere south of the Hudson lowlands. In either case, our findings suggest that red foxes were indigenous to the eastern US prior to or during colonial times, particularly in and around the Appalachian Mountains. For example, > 98% of the samples from the Appalachians or adjacent Piedmont from this and a previous study (Statham et al 2012) were indigenous eastern North American haplotypes.

Taken together, our findings based on maternal ancestry suggest that red foxes of the Appalachians and vicinity were distinct from red foxes at lower-elevation, more human-dominated landscapes of the mid-Atlantic coastal plain and Hudson lowlands. Although we found no significant isolation-by-distance relationship, the SAMOVA revealed a discrete subdivision between foxes of the Appalachians and vicinity ranging all the way from Georgia to Maine, which appeared mostly native, and those in the more densely human-dominated landscapes to the east in the mid-Atlantic coastal plain, which reflected an admixture of nonnative (European and fur-farm) and native maternal ancestry. Although we found European haplotypes also in western New York, the counties sampled overlapped or were situated within the Hudson lowlands, a highly populated corridor spanning Buffalo in the west, through Syracuse, to Albany in the east, and connecting with the extremely human-dense region of the mid-Atlantic coastal plain between Washington D.C. and New York City.

These findings were similar to findings in the West, where nonnative red foxes (in that case, solely from fur-farms) also appear to be associated closely with human-dominated landscapes and, perhaps, less able to thrive in more remote habitats, where their native counterparts predominate (Churcher 1959, Sacks et al 2010, Sacks et al 2011, Statham et al 2012, Frey 2013, Volkmann et al 2015). If so, the native dominance in the Appalachians and inability of the nonnative red foxes to thrive in less human-dominated landscapes could serve as a barrier to westward expansion of nonnative haplotypes, most notably European ones, from the eastern seaboard. On the other hand, the Hudson lowlands could provide a corridor for nonnative gene flow to the west. Future sampling west of the Appalachians but east of the Mississippi River is needed to better evaluate the western extent of European ancestry in North American red foxes.

In light of recent evidence supporting the previous classification of European and North American red foxes as distinct species (*Vulpes fulva*—Statham et al 2014), we also sought to assess the evidence for hybrid compatibility of these putative species. Our finding that individuals exhibiting a European haplotype (from its maternal or paternal side) also exhibited a North American haplotype from the other parent (in every case), clearly indicated that the two nominal species bred in the past and produced fertile offspring. Interestingly, however, the prevalence of mitochondrial European haplotypes was nearly an order of magnitude higher than that of European Y-chromosomes. In principle, this pattern could reflect a greater number of female than male founders from Europe, e.g., if only one male was introduced with several females. However, this seems unlikely based on evidence from the Australian introductions and anecdotes of the North American introductions (Long 2003; Frey 2013). When foxes were introduced they would likely have been introduced as breeding pairs to facilitate population

growth. It is possible instead that introduced males had lower fitness than the expanding Nearctic males due either to pre-zygotic (e.g., preference of native females) or post-zygotic (gametic incompatibility) causes. European females, on the other hand, could have been more successful due to lower selectivity of native males or asymmetric gametic compatibility.

The asymmetric establishment of the Y chromosome and mtDNA in the eastern US parallels the recently described evidence of a continental exchange of mitochondrial but not Y-chromosome lineages from Asian to Alaskan red foxes across the Bering land bridge during the last Pleistocene glaciation (Statham et al 2014). Both cases are also consistent with Haldane's (1922) rule, whereby male F_1 hybrids would be rare or sterile. If so, such a pattern indicates a degree of reproductive incompatibility between continental forms of red fox. Alternatively, the locally high frequency of European mtDNA haplotypes could reflect a selective sweep on particular mitochondrial mutations, in which case, these markers would provide a skewed sense of the amount of total European ancestry in eastern red foxes. In the future, it will be necessary to investigate autosomal markers to fully understand the geographic and genomic extent to which European red fox genes could have infiltrated North American red foxes.

ACKNOWLEDGEMENTS

Comments on an earlier draft of this manuscript by J. Frey and two anonymous reviewers helped to significantly improve this paper.

LITERATURE CITED

- AUBRY, K. B., M. J. STATHAM, B. N. SACKS, J. D. PERRINE, AND S. M. WISELY. 2009. Phylogeography of the North American red fox: vicariance in Pleistocene forest refugia. *Molecular Ecology* 18: 2668–86.
- AUDUBON, J. J., AND J. BACHMAN. 1849. *The viviparous quadrupeds of North America*. Privately published by J.J. Audubon, New York. Vol. 2.
- BANDELT, H. J., P. FORSTER, AND A. ROHL. 1999. Median-joining networks for inferring intraspecific phylogenies. *Molecular Biology and Evolution* 16:37–48.
- BENSON DA, CAVANAUGH M, CLARK K, KARSCH-MIZRACHI I, LIPMAN DJ, OSTELL J, AND E.W. SAYERS. 2013 GenBank. *Nucleic Acids Resources* 41: D36-D42
- CHURCHER, C. S., 1959. The Specific Status of the New World Red Fox. *Journal of Mammology* 4:513–520.
- DARRIBA, D., G. L. TABOADA, R. DOALLO, AND D. POSADA. 2012. jModelTest 2: more models, new heuristics and parallel computing. *Nature Methods* 9: 772.
- DEVILLARD, S., T. JOMBART, F. LÉGER, D. PONTIER., L. SAY, AND S. RUETTE. 2014. How reliable are morphological and anatomical characters to distinguish European wildcats, domestic cats and their hybrids in France? *Journal of Zoological Systematics and Evolutionary Research* 52:154–162.
- DRUMMOND, A. J., B. ASHTON, S. BUXTON, M. CHEUNG, A. COOPER, C. DURAN, M. FIELD, J. HELED, M. KEARSE, AND S. MARKOWITZ. 2014. Geneious Pro v6. 1.7. <http://www.geneious.com/>. Accessed 2014
- DUPANLOUP, I., SCHNEIDER, S., AND L. EXCOFFIER. 2002. A simulated annealing approach to define the genetic structure of populations. *Molecular Ecology* 11:2571-81.
- EXCOFFIER L, AND H. E. L. LISCHER. 2010. ARLEQUIN suite ver 3.5: A new series of programs to perform population genetics analyses under Linux and Windows. *Molecular Ecology Resources* 10:564–567.
- FREY, J. K. 2013. Re-evaluation of the evidence for the importation of red foxes from Europe to colonial America: Origins of the southeastern red fox (*Vulpes vulpes fulva*). *Biological Conservation* 158:74-79.
- FU, YX. 1997. Statistical tests of neutrality of mutations against population growth, hitchhiking and background selection. *Genetics* 147:915-925

- GENTON, B. J., J. A. SHYKOFF, AND T. GIRAUD. 2005. High genetic diversity in French invasive populations of common ragweed, *Ambrosia artemisiifolia*, as a result of multiple sources of introduction. *Molecular Ecology* 14:4275-4285.
- GIMONA, A., L. POGGIO, J. G. POLHILL, AND M. CASTELLAZZI. 2015. Habitat networks and food security: promoting species range shift under climate change depends on life history and the dynamics of land use choices. *Landscape Ecology* 30:771-789.
- HALDANE, J. B. S. 1922. Sex ratio and unisexual sterility in hybrid animals. *Journal of Genetics* 12: 101–109.
- HEWITT, G. 2000. The genetic legacy of the Quaternary Ages. *Nature* 405: 907-913.
- KAMLER, J. F., AND W. B. BALLARD. 2002. A review of native and nonnative red foxes in America. *Wildlife Society Bulletin* 30:370–379.
- KIDD, A. G., J. BOWMAN, D. LESBARRERES, AND A. I. SCHULTE-HOSTEDDE. 2009. Hybridization between escaped domestic and wild American mink (*Neovison vison*). *Molecular Ecology* 18:1175-1186.
- KIRK, H., J. PAUL, J. STRAKA, AND J. R. FREELAND. 2011. Long-distance dispersal and high genetic diversity are implicated in the invasive spread of the common reed, *Phragmites australis* (Poaceae) in northeastern North America. *American Journal of Botany* 98:1180-1190.
- LANGILLE, B. L., K. E. O'LEARY, H. G. WHITNEY, AND H. D. MARSHALL. 2014. Mitochondrial DNA diversity and phylogeography of insular Newfoundland red foxes (*Vulpes vulpes deletrix*). *Journal of Mammalogy* 95:772-780.
- LE ROUX, J. J., G. K. BROWN, M. BYRNE, J. NDLOVU, D. M. RICHARDSON, G. D. THOMPSON, AND J. R. U. WILSON. 2011. Phylogeographic consequences of different introduction histories of invasive Australian *Acacia* species and *Paraserianthes lophantha* (Fabaceae) in South Africa. *Diversity and Distributions*. 17:861-871.
- LONG, J. 2003. Introduced mammals of the world: their history, distribution and influence. CSIRO Publishing, Melbourne, Australia.
- MERRIAM, C.H. 1898. Life zones and crop zones of the United States. U.S. Department of Agriculture. Division of Biology. Survey Bulletin. 10:1-79.
- PERRINE, J. D., J. P. POLLINGER, B. N. SACKS, R. H. BARRETT, AND R. K. WAYNE. 2007. Genetic evidence for the persistence of the critically endangered Sierra Nevada red fox in California. *Conservation Genetics* 8:1083–1095.
- RAMBAUT, A., AND A. J. DRUMMOND. 2012. FigTree version 1.4. <http://tree.bio.ed.ac.uk/software/figtree/>. Accessed 2012

- RICCIARDI, A. 2007. Are modern biological invasions an unprecedented form of global change? *Conservation Biology* 21:329-336.
- SACKS, B. N., M. J. STATHAM, J. D. PERRINE, S. M. WISELY, AND K. B. AUBRY. 2010. North American montane red foxes: expansion, fragmentation, and the origin of the Sacramento Valley red fox. *Conservation Genetics* 11:1523–1539.
- SACKS, B. N., M. MOORE, M. J. STATHAM, AND H. U. WITTMER. 2011. A restricted hybrid zone between native and introduced red fox (*Vulpes vulpes*) populations suggests reproductive barriers. *Molecular Ecology* 20:326–341.
- SHIMODAIRA, H. 2002. An approximately unbiased test of phylogenetic tree election. *Systematic Biology* 51: 492-508.
- STATHAM, M. J., L. N. TRUT, B.N. SACKS, A.V. KHARLAMOVA, I. O. OSKINA, R. G. GULEVICH, J. L. JOHNSON, S. V. TEMNYKH, G. M. ACLAND, AND A. V. KUKKOVA . 2011. On the origin of a domesticated species: identifying the parent population of Russian silver foxes (*Vulpes vulpes*). *Biological Journal of the Linnean Society* 103:168– 175.
- STATHAM, M. J., B. N. SACKS, K. B. AUBRY, J. D. PERRINE, AND S. M. WISELY. 2012. The origin of recently established red fox populations in the United States: translocations or natural range expansions? *Journal of Mammalogy* 93:52–65.
- STATHAM, M. J., J. MURDOCH, J. JANECKA, K. B. AUBRY, C. EDWARDS, C. D. SOULSBURY, O. BERRY, Z. WANG, D. HARRISON, M. PEARCH, L. TOMSETT, J. CHUPASKO, AND B. N. SACKS. 2014. Range-wide multilocus phylogeography of the red fox reveals ancient continental divergence, minimal genomic exchange and distinct demographic histories. *Molecular Ecology* 23:4813-4830.
- SWOFFORD, D. L. 2003. PAUP:* Phylogenetic Analysis Using Parsimony (*and other methods). Version 4. Sinauer and Associates, Sunderland, Massachusetts.
- TAJIMA, D. 1989. Statistical method for testing the neutral mutation hypothesis by DNA polymorphism. *Genetics* 123:585–595.
- TOONEN, R. J., AND S. HUGHES. 2001. Increased throughput for fragment analysis on ABI prism 377 automated sequencer using a membrane comb and STRand software. *Biotechniques* 31:1320–1324.
- VALLADARES, F., S. MATESANZ, F. GUILHAUMON, M.B. ARAUJO, L. BALAGUER, M. BENITO-GARZON, W. CORNWELL, E. GIANOLI, M. VAN KLEUNEN, D.E NAYA, A.B. NICOTRA, H. POORTER, AND M.A. ZAVALA. 2014. The effects of phenotypic plasticity and local adaptation on forecasts of species range shifts under climate change. *Ecology Letters* 17:1352–1364.

VOLKMANN, L. A., M.J. STATHAM, A. Ø. MOOERS, AND B. N. SACKS. 2015. Genetic distinctiveness of red foxes in the Intermountain West as revealed through expanded mitochondrial sequencing. *Journal of Mammalogy* 96:297–307.

APPENDIX

Table A1: Results from the Shimodaira approximately unbiased (AU) test that compared the likelihoods of different phylogenetic trees. In this case, it tested the maximum likelihood tree with no bounds (ML) with the maximum likelihood trees with various restrictions: one in which all samples from this study were bound to global Nearctic samples, one with samples from this study bound together, and one in which samples were bound with Holarctic samples. The results supported previous analyses indicating distinct “Nearctic” and “Holarctic” clades, with a North American subclade nested within the otherwise Eurasian Holarctic clade.

Tree	-ln L	Diff -lnL	AU p-value
ML Tree	2441.37079	(best)	
Nearctic	2476.20072	34.82993	0.1010
Samples	2618.55742	177.18663	P<0.05
Holarctic	2641.25383	199.88304	P<0.05

Chapter 3

History of the native red fox in the eastern United States: Identifying the impacts of spatial expansion and translocation on the structure of a mobile generalist

In Review in Conservation Genetics

by

A.E. Kasprovicz and B. N. Sacks

March 2016

ABSTRACT

Identifying the natural versus anthropogenic origins of newly founded wildlife populations has important implications for management and conservation. We attempted to identify the relative impact of native expansion versus human mediated introductions of both colonial era European foxes and early 20th century fur-farm foxes on the establishment of red foxes in the mid-Atlantic region of the United States. We did this by characterizing the genetic structure of existing populations and attempting to detect genetic signatures of expansion and admixture across the landscape. We found low genetic structure overall despite the broad geographic scale of our study area, which we attribute both to range expansion and admixture. We also found evidence for differential patterns of expansion related to habitat. Specifically, the Appalachian Mountains acted as a corridor for gene flow from the northern native source into the southern Mid-Atlantic region.

Keywords:

Eastern United States, European red fox, population genetics, landscape genetics, red fox, *Vulpes vulpes*, expansion

INTRODUCTION

When a species is first observed in a habitat there are several potential explanations or sources. They can reflect natural range expansion of a nearby population, invasion/introduction from an outside population, the demographic expansion of an existing, small population, or any combination therein. European colonization of the Americas brought with it massive changes in the land, which in turn altered the relative abundances and community composition of species, often before biodiversity could be adequately catalogued and mapped by 19th century naturalists (Pimm et al 1995). Consequently, we are often left to infer pre-colonial species ranges from contemporary and fragmentary historical information. For this purpose, genetic approaches have become useful tools as new simulation and applied studies have identified genetic patterns of recent expansions and invasions (Allendorf and Lundquist 2003; Excoffier 2004; Ricciardi 2007; Excoffier et al 2009; Slatkin and Excoffier 2012; Mona et al 2014; Hagen et al 2015).

Over the past 300 years red foxes (*Vulpes vulpes*) have become established in many parts of the United States where they had been absent historically. Some of these recent populations stemmed from expansions of native populations, whereas others derived from human translocations of captive-farmed or wild-caught animals (Sacks et al 2010; Statham et al 2012; Kasprovicz et al 2016). The earliest such populations occurred along the eastern seaboard, and were thought to have originated from southward expansion from northern indigenous populations, introductions of European red foxes, or both (Churcher 1959; Kamler and Ballard 2002; Statham et al 2012; Frey 2013). The historical record suggests that red foxes occurred no further south than New England at the time of European colonization (Frey 2013). On the other hand, late Holocene remains of red foxes occurred as far south as Georgia (Statham et al 2012; Frey 2013). Thus, red foxes could have occurred historically at low numbers along the entire

length of the Appalachians and adjacent forests, despite the lack of historical documentation. Alternatively, red foxes potentially disappeared from the southern Appalachians prior to European colonization only to re-enter the region via range expansion from the north after European colonization (Statham et al 2012).

Based on mitochondrial and Y chromosome analysis, previous studies found that contemporary red foxes in the eastern United States reflected multiple sources, including native eastern North American red foxes and introduced red foxes from captive-farmed and European sources (Statham et al 2012; Kasprovicz et al 2016). Native haplotypes predominated along the Appalachian Mountains and adjacent piedmont, whereas nonnative (i.e., European and fur-farm) haplotypes were most common along the coastal plain and in the Hudson River Valley. We hypothesized that the more densely human-populated lowlands favored the nonnative invasive foxes, whereas the less human-impacted Appalachians reflected natural habitat for native red foxes and, consequently, acted as a longitudinal barrier to the westward spread of nonnative foxes. Although these findings generally confirmed the natural occurrence of native red fox ancestry along the latitudinal length of the Appalachian Range and adjacent habitats in contemporary populations, autosomal genetic markers would have been needed to quantify admixture and investigate the historical demography of the native component of the population.

While mitochondrial DNA is exceptionally useful for tracing population divergence due to its ubiquity, non-recombining and haploid nature, and its mutation rate, matrilineal markers only provide a partial indicator of gene flow and genetic diversity (Avisé and Ellis 1986; Avisé et al 1987). It is particularly important when studying populations that are either recently derived or have a likelihood of admixture to include nuclear loci (Geraldès et al 2008).

Microsatellites (μ sats), in particular, are used in population studies because they are neutral, have

high polymorphism even in populations with low diversity, are co-dominant, and can be implemented through high throughput genotyping methods (Maudet et al 2002; Kelkar et al 2010; Guichoux et al 2011).

Because range expansion and non-native introductions can generate distinct geographic patterns of genetic diversity, use of multiple genetic markers can help to differentiate these demographic processes (Hagen et al 2015; Norén et al 2015). Natural range expansions tend to occur in a stepwise pattern with genetic differentiation increasing from the source (Schrey et al 2014). Typically, this expansion results in serial founder effects along the expansion fronts (Slatkin and Excoffier 2012). The influence of drift on the expansion front is expected to increasingly reduce overall allelic diversity along the axis of the expansion front, but also to increase the frequency of some rare alleles, a process dubbed ‘gene surfing’ (Excoffier and Ray 2008; Hallatschek and Nelson 2008). When colonization distance is large relative to average dispersal distance, gene surfing can result in increasing genetic differentiation of populations along the expansion front from the source population (Hallatschek and Nelson 2008).

Empirically, however, expansions in highly vagile organisms, such as terrestrial carnivores, tend to be rapidly followed by genetic homogenization across the newly colonized region, but, due to low gene flow back into the source population, also retain some genetic differentiation from the source population (Hagen et al 2015; Norén et al 2015). This results in relatively discrete differentiation between the original and new portion of the range and lower overall genetic diversity in the latter. In contrast, establishment of introduced or invasive species often entails genetic bottlenecks as new populations are founded by small numbers of colonists (Allendorf and Lundquist 2003). In successful invaders, this is often overcome by repeat introductions from different source populations (Sakai et al 2001; Kowarik 2003; Allendorf and Lundquist 2003).

One expectation is that there is higher diversity in newly founded populations than in the source populations and strong differentiation if independent introductions occur across a landscape.

In this paper we attempt to identify the relative impact of native expansion versus human-mediated introductions on the establishment of red foxes in the mid-Atlantic region of the United States. Because eastern red foxes apparently contain admixture from nonnative sources, especially on the coastal lowlands and Hudson River Valley (Kasprowicz et al 2016), we first characterized the genetic structure of existing populations with respect to native and nonnative admixture. In particular, we tested the *a priori* hypothesis based on mtDNA that upland, Appalachian populations were primarily native while lowland, valley populations were most impacted by introduced European and farmed red fox and compared the results with mtDNA patterns. We then attempted to tease apart the effects of this admixture from signatures of natural expansion from the north. To investigate the hypothesis of a natural southern range expansion from the northern Appalachians, we tested the following predictions: (1) a genetic subdivision between the northern Appalachians and the putatively newly colonized southern Appalachians and lowlands, (2) a decline in genetic diversity with distance to the south and, depending on nonnative admixture, east, and (3) higher connectivity among Appalachian populations.

METHODS

We collected and extracted DNA from locations throughout the eastern United States (Fig. 1), as described previously (Kasprowicz et al 2016). For the present study, we used a subset of 391 individuals. Thirty individuals from each location were randomly selected unless n was <30 in which case the entire sample was used. Vermont (VT) was the only sampling

location in our study where red foxes were known to occur prior to European colonization and therefore represented the putative source of native expansions.

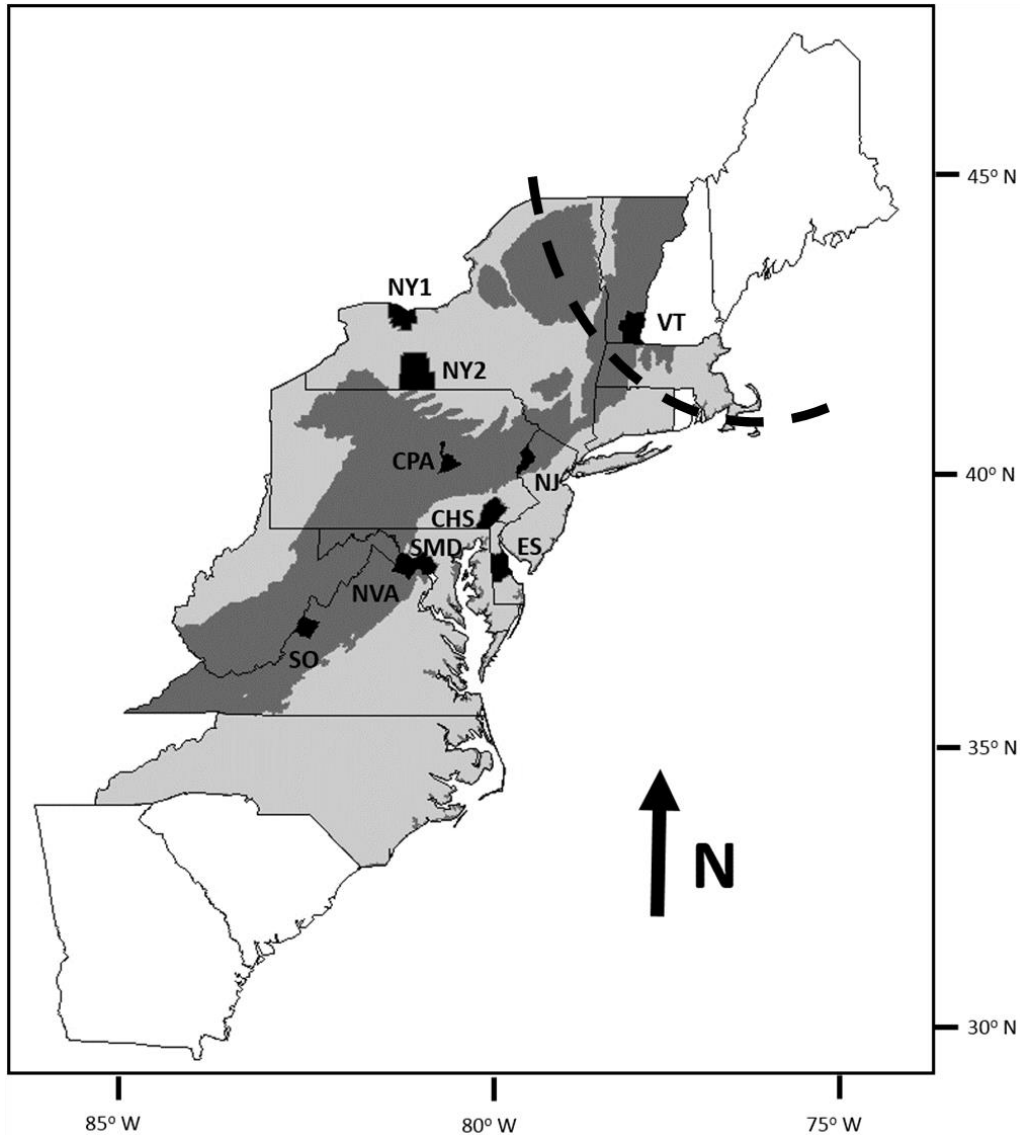

Figure 1: Map of 10 counties (black) where 342 red foxes were sampled during 2011–2013 in relation to the Appalachian Mountain Range. The Vermont (VT) population represents the southern extent of the pre-European range of the red fox, whereas all other sites were potentially colonized or introduced subsequently. Dashed line indicates known pre-European range. Light grey represents the area classified as “Lowland” and dark grey represents “Mountain” in the resistance models. Sampling locations (counties) are abbreviated as Vermont (VT), northwest New York (NY1), southwest New York (NY2), New Jersey (NJ), central Pennsylvania (CPA), Chesapeake (CHS), Eastern Shore/Delmarva Peninsula (ES), southern Maryland (SMD), northern Virginia (NVA), and southern Virginia (SO).

We amplified 22 microsatellite loci: AHT140, Vv-C01.424, FH2004, Vv-FH2010, Vv-FH2088, FH2289, Vv-AHT171, Vv-CPH11, Vv-CPH18, Vv-CXX-468, Vv-CXX-602, Vv-FH

2848, Vv-REN54 P11, Vv-AHT133, Vv-FH2328, Vv-C08.618, Vv-FH2001, Vv-FH2054, Vv-FH2457, Vv-CPH2 (Wandeler & Funk 2005; Moore et al 2010; Sacks et al 2011). Forward primers were fluorescently labeled (6-FAM, VIC, NED, PET; Applied Biosystems). We conducted polymerase chain reactions (PCR) in three multiplex groups as described by Moore et al (2010) using the Qiagen multiplex kit using “Q-solution” according to the manufacturers recommended protocols. All microsatellite laboratory work was performed at the Mammalian Ecology and Conservation Unit at the Veterinary Genetics Laboratory at the University of California, Davis. Products were electrophoresed along with an internal size standard Genescan 500 LIZ (Applied Biosystems Foster City, CA, USA) on an ABI 3730 capillary sequencer (Applied Biosystems). Alleles were scored using STRand software (Toonen and Hughes 2001).

Population Differentiation.

We examined population differentiation across the landscape to trace connectivity and distribution patterns. First, we used traditional F-statistics. We used GenePop on the Web (<http://genepop.curtin.edu.au/>; Raymond and Rousset 1995; Rousset 2008) to assess deviations from Hardy-Weinberg and linkage equilibrium. We then used GenAlex (Peakall and Smouse 2006) to calculate observed and expected heterozygosity, F_{IS} , number of alleles, and private alleles. Because sample sizes varied across sites, we used ADZE 1.0 to create rarefaction curves of numbers of alleles per locus and numbers of private alleles per locus standardized to the smallest sample size (Szpiech et al 2008). We calculated pairwise population differentiation under F_{ST} and tested for significance using 10,000 permutations in Alrequin 3.5 (Excoffier et al 2005).

To gain further insight into the connectivity of the sampled locations we used an individual-based assignment approach implemented with program Structure v2.3 to identify genetic clusters on the basis of minimizing departures from Hardy-Weinberg and linkage equilibrium and the level of admixture between them (Pritchard et al 2000). We applied the correlated allele frequency and admixture models without priors of population membership (Falush et al 2003). Initially, we ran 10 replicates for each predetermined number of clusters (K) from 1–20 using 100,000 iterations following 10,000 burn-in cycles. After determining that $\text{Pr}(X|K)$ was highest for $2 \leq K \leq 9$ we ran an additional 20 replicates of 750,000 (250,000 burn-in) cycles for K , 2–9. To enhance sensitivity to potentially weak structure, we repeated this analysis using the LOCPRIOR setting, which uses prior information on proximity of sampling locations to help identify structure (Hubisz et al 2009). Locations corresponded to county centroids. We then used the program CLUMPAK to combine and visualize the results across all values of K for comparison (Kopelman et al *in press*). We evaluated the optimal number of clusters based on both the $\text{Pr}(X|K)$ method suggested by Pritchard and Wen (2000) as well as the ΔK method (Evanno et al 2005). Pritchard et al (2005) suggest using the lowest value of K with the highest likelihood that also makes biological sense.

In addition to assignment methods, we used multivariate statistical analysis to build graphical representations of structure without *a priori* assumptions of Hardy-Weinberg or linkage equilibrium. We performed a principal coordinates analysis (PCoA) using GenAlEx to project individual genotypes onto 2-dimensional space based on Nei's D in order to visualize patterns of genetic relatedness among samples (Peakall and Smouse, 2012). Multi-dimensional scaling methods such as this one enable the identification of relatedness between individuals within populations in relation to individuals across populations.

Expansion

To test for a stepping-stone model of expansion, which assumes an equilibrium between gene flow and drift, we used GenAlex to assess isolation by distance (IBD) using a Mantel test on F_{ST} values as a function of straight-line Euclidean distances separating centroids of sampling locations. A signature of range expansion is the presence of genetic clines with divergence between the source and colony (Excoffier and Ray, 2008; Ray and Excoffier 2010; Niedzialkowska et al 2014). Isolation by Distance increases the genetic differentiation between individuals as geographic distance increases resulting in strong differentiation between the edge and the source (Mantel, 1967). To test for a recent expansion, where diversity was expected to decline with distance from the source, we performed a linear regression on allelic richness and average heterozygosity against increasing distance from the VT population.

Impact of the Appalachian Mountain Range

To test the *a priori* hypotheses regarding the distribution of native and introduced red foxes, we performed analyses of molecular variances (AMOVA) based on F-statistics (Excoffier et al 2005). The first hypothesis used the groupings that a SAMOVA on mtDNA identified as maximizing genetic variance between groups of populations (Kasprowicz et al 2016). The second AMOVA compared sites with European mtDNA to those with exclusively native mtDNA. The final AMOVA tested whether habitat significantly explained differentiation by comparing sites that are geographically within the Appalachian Range versus those that were lowland regardless of mitochondrial haplotypes present. Additionally, we applied a spatial analysis of molecular variance (SAMOVA) to assess population structure without *a priori* constraints (Dupanloup et al 2002).

Landscape resistance

To test our hypothesis that the Appalachians facilitated movement among native red foxes and inhibited movement of lowland red foxes, we created two opposing landscape resistance surfaces, each of which we tested against the corresponding populations. The first surface treated the Mountain zones as low resistance and the Lowland zones as high resistance and was tested against the Mountain sampling sites (Fig. 1). The second surface treated the Lowland zones as low resistance and the Mountain zones as high resistance and was tested against the Lowland sampling sites (Fig. 1). We applied circuit theory to assess the relationship between genetic differentiation and landscape resistance using the program Circuitscape (Shah and McRae 2008). We created hypothetical resistance surfaces using ArcGIS version 10.3 (ESRI, Redlands California). We used the USGS habitat map and reclassified each region into its binary classification based on the USGS definition of each region. This resulted in the following categorization of sample sites: VT, NJ, CPA, NVA, and SO were considered Mountain and NY1, NY2, CHS, SMD, and ES were considered Lowland (Fig. 1). To tune our surfaces, we tested three ratios of resistance between high and low: 1:10, 1:5, and 1:2. We then performed partial Mantel tests in R using the VEGAN package (Oksanen et al 2015) to compare genetic distance to resistance distance while controlling for geographic (Euclidian) distance.

RESULTS

Summary Statistics

We successfully amplified ≥ 20 loci in 342 individuals. All loci were polymorphic but genetic diversity varied across sites (Table 1). Although several loci were significantly out of Hardy-Weinberg equilibrium (HWE) in some sampling sites, no particular locus consistently

deviated from HWE across sites (Supporting Information Table S1). Likewise, only 5 of 2100 comparisons for LD were significant after sequential Bonferroni correction.

Table 1: Summary statistics by sampling site based on genotypes of 342 red foxes sampled in the eastern United States 2011–2013. Sampling locations are abbreviated as Vermont (VT), northwest New York (NY1), southwest New York (NY2), New Jersey (NJ), central Pennsylvania (CPA), Chesapeake (CHS), Eastern Shore/Delmarva Peninsula (ES), southern Maryland (SMD), northern Virginia (NVA), and southern Virginia (SO). For each site the number of individuals included (n), the average number of alleles (N_A), allelic richness (A_r), observed heterozygosity (H_O), expected heterozygosity (H_E), and inbreeding coefficient (F_{IS}). Allelic richness was standardized for $n = 23$, which was the smallest n when the SO population was removed.

Sampling Site	n	N_A	A_r	H_O	H_E	F_{IS}
VT	23	5.33	4.57	0.606	0.626	-0.005*
NY1	58	7.14	5.31	0.700	0.707	-0.002*
NY2	23	5.91	5.12	0.686	0.681	-0.032
NJ	53	6.91	5.26	0.640	0.688	0.059*
CPA	29	6.33	5.34	0.665	0.698	0.026
CHS	46	6.91	5.29	0.682	0.706	0.024*
ES	30	5.71	4.80	0.687	0.698	-0.001*
SMD	30	5.76	4.88	0.679	0.701	0.013*
NVA	44	6.05	4.94	0.660	0.698	0.044*
SO	6	5.81	---	0.690	0.708	-0.077
Total/Average	342	6.07	5.04	0.67	0.691	0.005

Population Structure

For the Structure analysis with no prior information, each method used to assess the “best” number of discrete subpopulations (K) indicated a different optimum (Fig. 2). At all K , VT contained the highest frequency of assignments with $q > 70\%$, and these were almost all $>90\%$ (Fig. 3A). Regardless of K , however, few individuals in the other populations assigned to any subpopulation with $q > 70\%$ indicating high levels of admixture. Therefore, we present K ranging 2–10 (Fig. 3A).

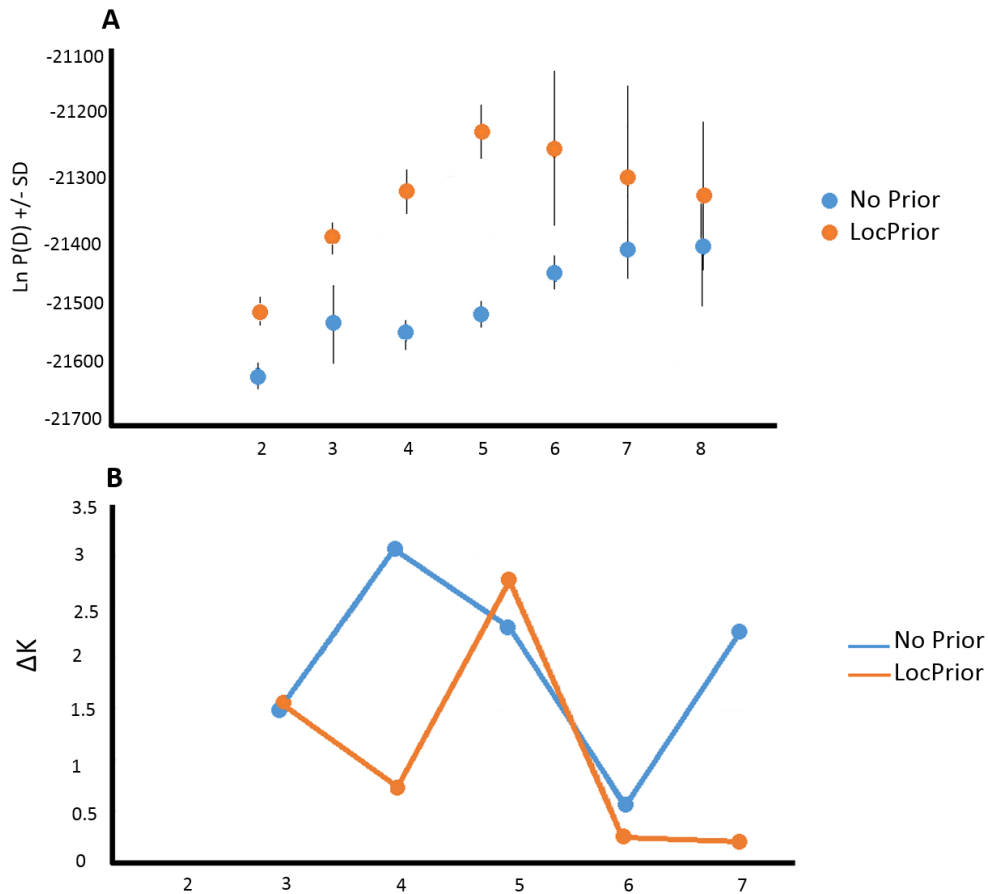

Figure 2: Graphs to determine optimal value of clusters (K) based on (A) the log probability of the data [LnP(D)] and (B) the ΔK method. Blue lines/dots represent simulations with no prior information while orange represents those run with a location prior added to the model.

When the LocPrior setting was used, both methods supported $K = 5$ as the optimal value of ΔK (Fig. 2). Nevertheless, as with the analysis with no prior information, qualitative patterns of admixture were similar regardless of K (Fig. 3B). At $K = 6$, only 14% of individuals could be assigned to a group with $q > 70\%$. Again, VT was the most distinguishable site. However, NVA also became distinct in this set of analyses, as did NJ at $K > 5$. All individuals in VT were assigned to one cluster at $q > 90\%$ and all but one of the NVA foxes was assigned to another cluster at $q > 90\%$.

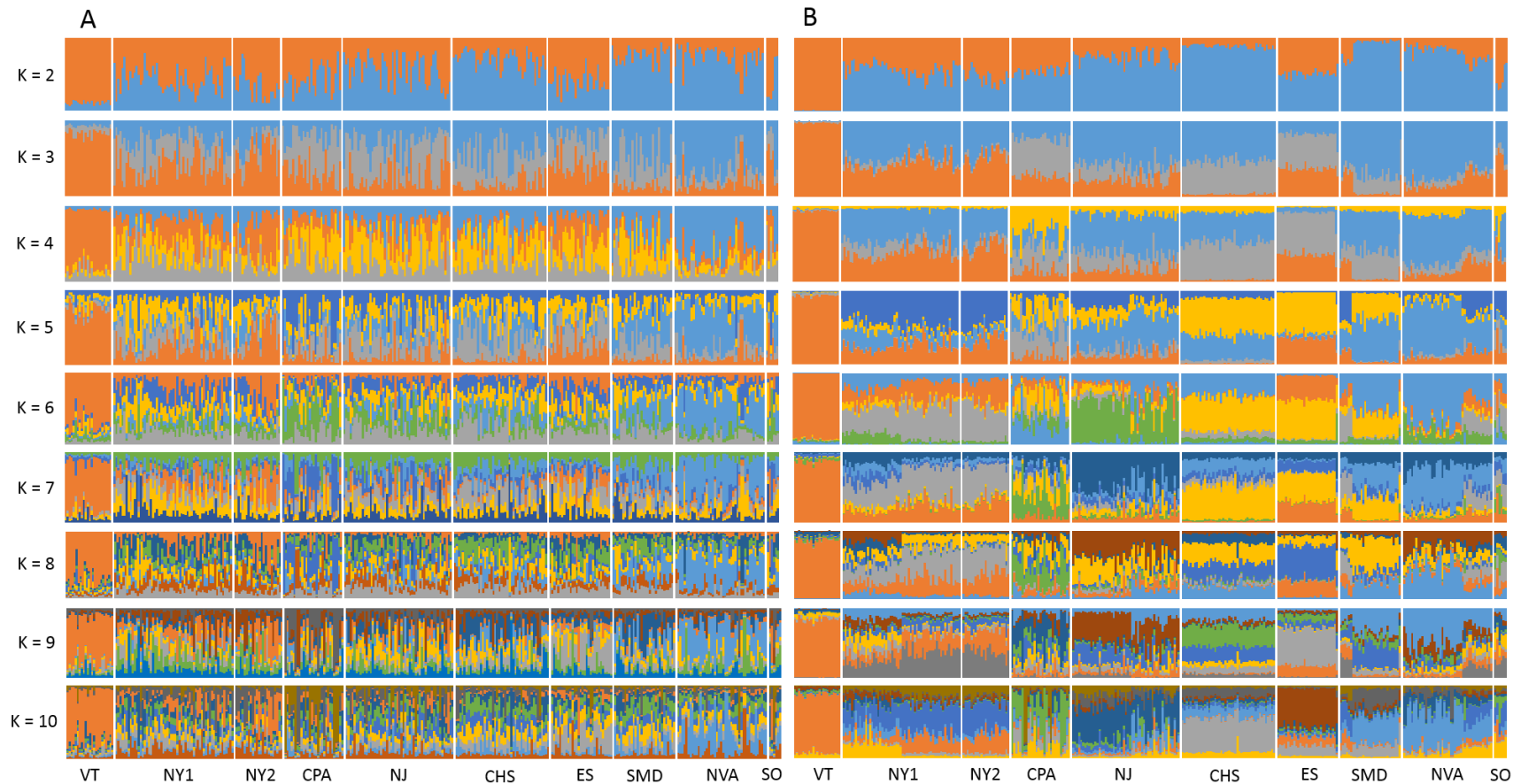

Figure 3: Results of Structure analysis of the genotypes of 342 red foxes sampled in the eastern United States 2011–2013, where each vertical line represents the genetic composition of one individual within the labeled sample locations. Results without location prior (A) and results with location prior (B).

Similarly to the Structure analyses, the SAMOVAs indicated statistically significant divisions corresponding to $K = 3-9$ and F_{CT} values increased with increasing K (Fig 4). Importantly, the highest F_{CT} corresponded to $K = 9$, which distinguished all sampling sites except SO and NY2, which were grouped together. These two sites were far apart in terms of geographic distance but both occurred within the Appalachian Mountains. The VT site was distinct from all others at $K = 2, 6-9$, whereas the NVA site was distinct at $K = 3-9$. Although iterations corresponding to increasing K were not perfectly nested, CHS and SMD tended to cluster together as did SO, NY, and NY2. Lastly, CPA and NJ clustered together for $K < 7$.

	VT	NY1	NY2	CPA	NJ	CHS	ES	SMD	NVA	SO	F_{CT}
$K = 2$	B	A	A	A	A	A	A	A	A	A	0.020
$K = 3$	B	B	B	B	B	A	B	A	C	B	0.018*
$K = 4$	B	B	B	A	A	D	B	D	C	B	0.019*
$K = 5$	B	F	A	E	E	D	F	D	C	B	0.022*
$K = 6$	B	A	A	E	E	D	F	D	C	A	0.025*
$K = 7$	B	A	A	G	E	D	F	D	C	A	0.028*
$K = 8$	B	A	A	G	E	D	F	H	C	A	0.035*
$K = 9$	B	I	A	G	E	D	F	H	C	A	0.062*

* $p < 0.05$

Fig. 4 The results of SAMOVA analyses of the genotypes of 342 red foxes sampled in the eastern United States 2011–2013, based on optimal groupings at each given value of K that maximally differentiates each group.

The AMOVA results showed only 4% of the genetic variation was due to differences across locations, 5% among individuals, and 91% within individuals. Two of the hypothesis driven AMOVAs were significant, but generally of low explanatory value (Table 2). The SAMOVA comparison at the same level of K (i.e., $K = 2$) indicated greater support than any of these a-priori groupings, in particular, for VT vs. all other populations.

Table 2: Hypothesis- driven AMOVA’s based on *a priori* information from landscape data and mtDNA groupings from a previous study (Kasprowicz et al 2016) tested with genotypes of 342 red foxes sampled in the eastern United States 2011–2013: “K2 SAMOVA” was created on distribution of populations from the optimal K = 2 SAMOVA analysis in Kasprowicz et al 2016; “European” divides sites between those with European mitochondrial haplotypes versus those without; “Mountain/Lowland” compared populations defined in the text as ‘Mountain’ or ‘Lowland’.

		F_{ST}	F_{SC}	F_{CT}
K2 SAMOVA	1: NJ, ES, CHS, SMD, NVA, 2: NY, NY2, CPA, VT, SO	0.038*	0.031*	0.007*
European	1: CPA, VT, SO 2: NY, NY2, NJ, ES, CHS, SMD,NVA	0.042*	0.031*	0.012*
Mountain/Lowland	1: VT, NJ, CPA, NVA, SO 2: NY1, NY2, CHS, ES, SMD	0.034*	0.035*	-0.002

All but 7 pairwise F_{ST} comparisons between individual sites were significant, but with low to moderate differentiation across most sites (0.016–0.092, Table 3). Each of the non-significant comparisons involved the SO population which had a small sample size ($n = 7$). Both F_{ST} and comparisons based on Nei’s D identified VT as strongly differentiated from all other sites.

The PCoA similarly revealed the VT site was distinct as well and revealed additional differentiation among sites. Specifically, VT clustered with CPA and SO, the two other populations that were included within the Appalachian system. (Fig. 5)

Table 3 – Pairwise genetic distances between locations based on genotypes of 342 red foxes sampled in the eastern United States 2011–2013. Above the diagonal are Nei’s D_A estimates. Below the diagonal are F_{ST} estimates.

	CHS	CPA	ES	NJ	NVA	NY	NY2	SMD	SO	VT
CHS	-	0.102	0.084	0.064	0.080	0.063	0.110	0.039	0.059	0.229
CPA	0.037*	-	0.102	0.081	0.115	0.082	0.100	0.112	0.043	0.161
ES	0.032*	0.041*	-	0.074	0.128	0.045	0.086	0.079	0.055	0.104
NJ	0.026*	0.034*	0.032*	-	0.076	0.043	0.062	0.048	0.040	0.104
NVA	0.030*	0.047*	0.051*	0.032*	-	0.066	0.085	0.057	0.029	0.208
NY	0.023*	0.033*	0.019*	0.019*	0.027*	-	0.017	0.061	0.00	0.098
NY2	0.041*	0.043*	0.036*	0.027*	0.036*	0.007*	-	0.092	0.00	0.061
SMD	0.016*	0.044*	0.033*	0.021*	0.023*	0.024*	0.037*	-	0.045	0.215
SO	0.020*	0.011	0.018	0.015	0.009	0.000	0.000	0.016	-	0.072
VT	0.091*	0.075*	0.051*	0.074*	0.090*	0.047*	0.033*	0.092*	0.037*	-

* $P < 0.05$ (F_{ST} estimates only)

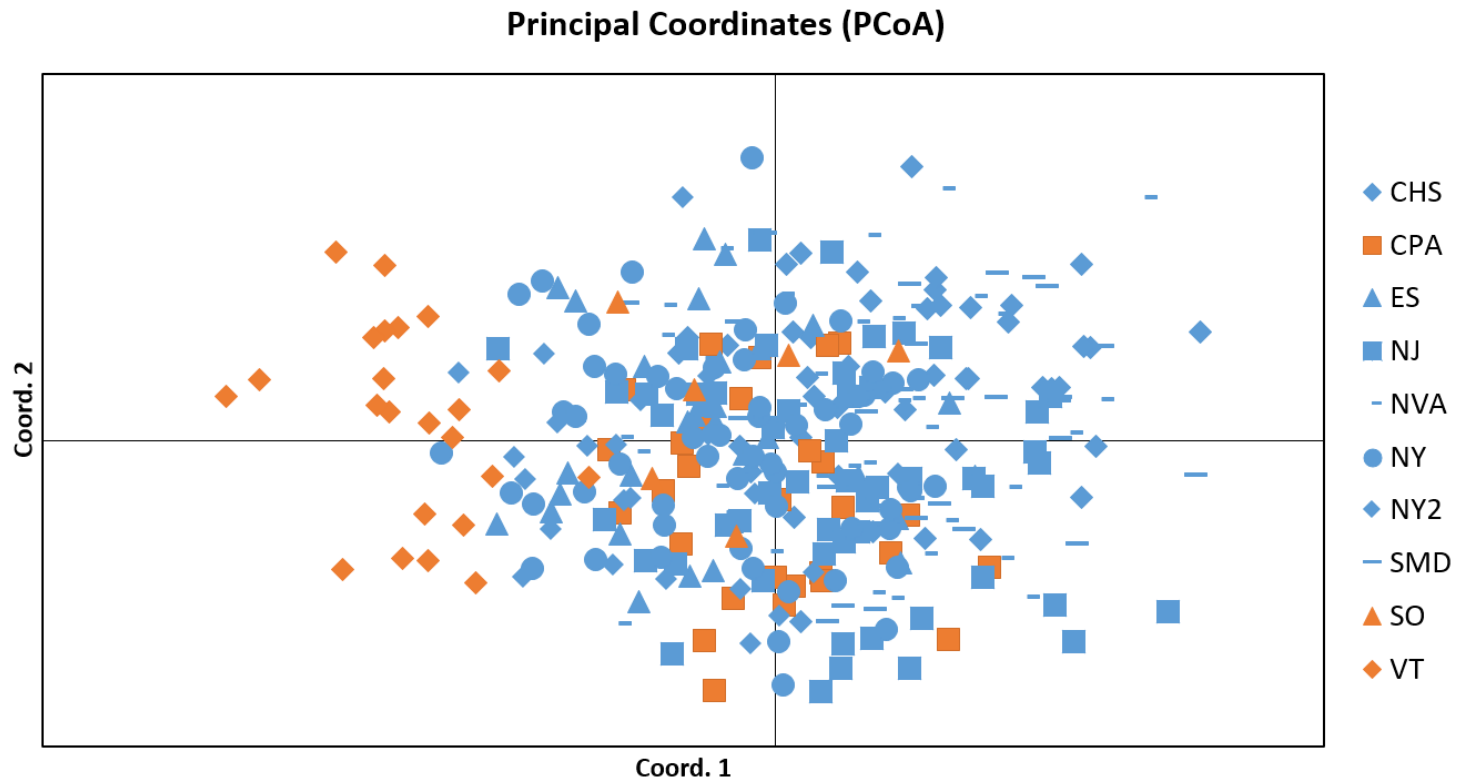

Figure 5: Principal Coordinates Analysis (PCoA) of the genotypes of 342 red foxes sampled in the eastern United States 2011–2013. Orange markers represent sites that were previously classified based on mtDNA (Kasprowicz et al 2016) as “mostly native” while blue are locations are those that are more strongly influenced by introduced (European or fur-farm) haplotypes.

Expansion

A simple Mantel test of genetic versus Euclidian distance was not significant ($r = -0.181$, $P = 0.22$). Further, we observed no correlation between genetic and geographic distances when examined separately within Mountain and Lowland sites (Fig. 6a). Of the two diversity measures, only A_r was significantly correlated with distance from the VT site ($r = -0.72$, $P = 0.044$; Fig. 6b). However, the VT site had the lowest A_r overall, possibly because it was least affected by nonnative admixture ($A_R = 4.57$). We observed no significant relationship between H_O or H_E and distance from VT ($r_{H_O} = 0.011$, $P_{H_O} = 0.588$; $r_{H_E} = 0.012$, $P_{H_E} = 0.597$).

Resistance surface models

Plots of genetic distance on resistance distance suggested a weak positive relationship for the Mountain dataset but none for the Lowland dataset (Fig. 7). The partial Mantel tests for isolation by resistance indicated a strong relationship for the Mountain comparisons when controlling for Euclidian distance ($r_{\text{resist}} = 0.92$, $P < 0.05$). The converse relationship, genetic distance versus Euclidean distance, holding resistance distance constant, was not significant ($r_{\text{geog}} = -0.899$, $P = 0.967$). Neither partial Mantel test was significant for the Lowland model ($r_{\text{resist}} = -0.123$, $P = 0.575$; $r_{\text{geog}} = 0.246$, $P = 0.242$).

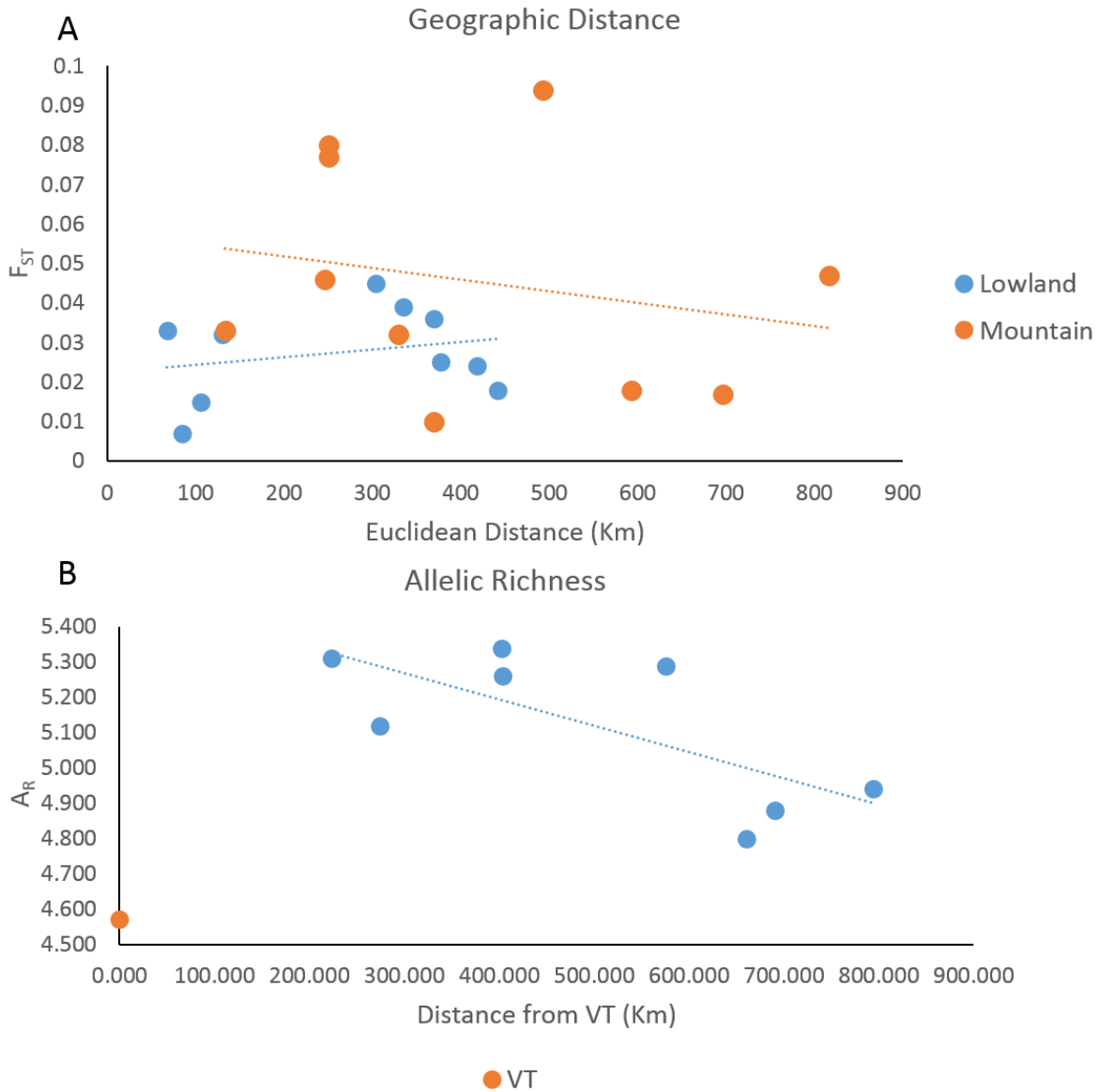

Figure 6 Graphs of (A) genetic distance (F_{ST}) versus geographic distance and (B) allelic richness (A_R) versus Euclidean distance from VT 342 red foxes sampled in the eastern United States 2011–2013. Comparisons between Lowland sites are in blue and between Mountain sites are in orange, with corresponding trend lines similarly colored.

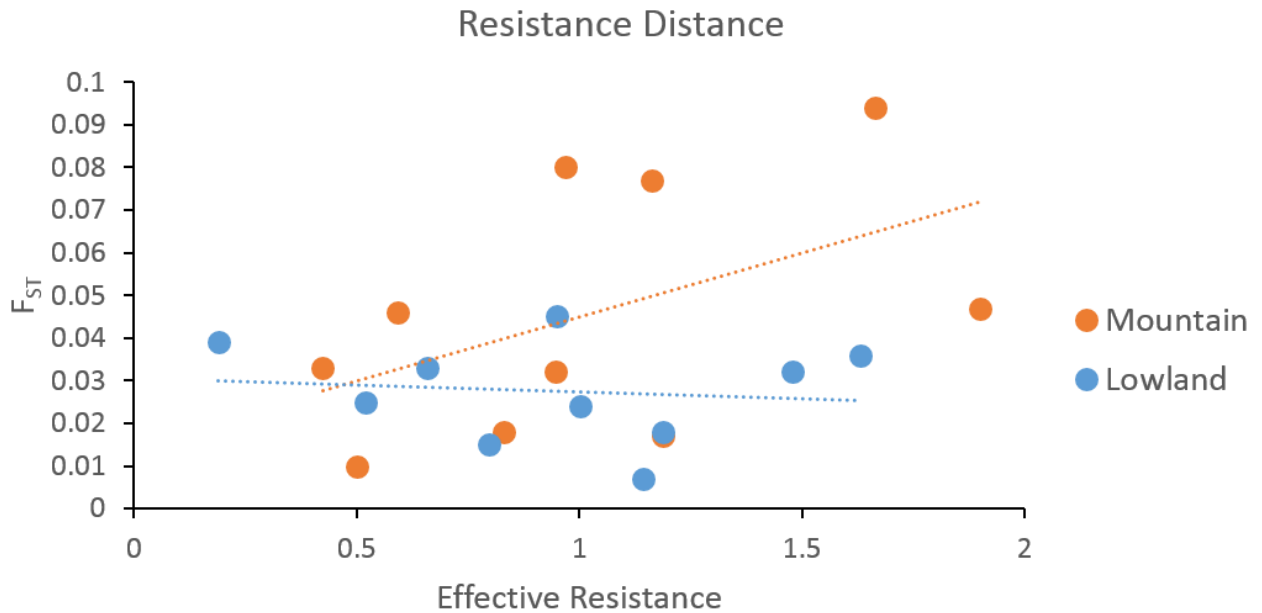

Figure 7: Graph of genetic distance (F_{ST}) versus resistance distance, based on genotypes of 342 red foxes sampled in the eastern United States 2011–2013. The Mountain model is represented in orange while the lowland model is represented in blue.

DISCUSSION

In this study we sought to understand the ascendance of red fox populations in the eastern United States. The increase in distribution and abundance of red foxes corresponded in time with European (human) colonization (Statham et al 2012; Frey 2013). The result was ambiguity as to the source of these red foxes. Previous mitochondrial analyses identified both native and nonnative haplotypes, indicating that both natural expansion and introduction of foreign foxes contributed (Kasprovicz et al 2016). The nuclear genetic results of the present study indicated differential patterns of native vs. nonnative expansion related to habitat. In particular, the Appalachian Mountains served as a corridor facilitating southward gene flow from the northern native source.

Expansion and Admixture

The relatively low genetic structure despite geographic distance and potentially impactful landscape features is suggestive of either a recent expansion or strong admixture due to high gene flow. Vermont was the only site included in this study that was known to be a part of the historic range (i.e., pre-colonial) of eastern red fox populations, and, therefore, hypothesized to represent the source of natural range expansion. As predicted, VT was discretely differentiated from all the sites in the newly colonized portion of the range, a pattern expected under range expansion (Excoffier and Ray 2008; Hallatschek and Nelson 2008). Indeed, all Structure analyses grouped VT as its own cluster, even when prior information of sampling location was disregarded, while failing to identify any other consistent cluster. The VT location also had the lowest number of distinct alleles across sites but the highest number of private alleles.

In contrast, we observed a lack of clear structure among all other locations. Although this pattern was potentially explained by high contemporary gene flow, a more likely explanation was that they became established from a recent expansion, after European colonization, in which case time might not have been sufficient for gene flow and drift to reach equilibrium. The reduction in allelic richness with increasing distance from VT also supports a recent expansion, as dispersing alleles undergo bottlenecks which reduce the overall number of alleles.

However, the genetic patterns suggested that red fox range expansion was a much more complex and dynamic process than what is expected under a simple model of natural range expansion. In particular, non-native admixture clearly was a significant part of the equation. In general, non-native populations can be introduced into two basic scenarios: 1) habitats without conspecifics and 2) habitats with conspecifics. The first scenario would result in founder effects and strong genetic drift resulting in reduced genetic diversity. Assuming introduction to multiple

different locations, drift would likely result in strong differentiation among sites (Sacks et al in review). With the second scenario, we would expect high admixture, outbreeding, and an increase in genetic diversity. Structure among multiple populations would depend on the pre-existing differentiation and levels of gene flow. In our study, genetic diversity was highest at mid-latitudes probably due to having the highest admixture among the three sources (native, European, fur-farm). The three populations with greatest distance from VT and lowest A_R were ES, SMD, and NVA. Throughout sites south of VT, individuals were assigned to multiple genetic groups with admixture proportions ranging 20–80%. Thus, as indicated previously with mitochondrial DNA (Kasprowicz et al 2016), introductions from Europe and fur farms apparently also increased the nuclear genetic diversity of the Eastern red fox south of the known historical range.

The Appalachian Mountains

It was unclear from the data whether the Appalachian population extended to southern Virginia before or after European colonization, but was apparent that the Appalachians acted as a conduit for native gene flow at least in the contemporary if not historical population. Landscape fragmentation can subtly affect genetic patterns of expansion (Mona et al 2014). For the most part, it decreases the number of observed haplotypes, thus overall diversity, through increased genetic drift. However, this is not as obvious at the landscape level as it is at the deme or patch level (Mona et al 2014). Our results support the hypothesis that red foxes along the Appalachian Mountain range, which had been shown to be predominantly native in origin (Statham et al 2012; Kasprowicz et al 2016), experienced a higher connectivity to each other than to those found in the surrounding lowland habitats. Whereas a Mantel test did not detect isolation by distance, we

found a significant correlation between genetic and resistance distance (i.e., isolation by resistance) consistent with higher connectivity across sampling sites within the Appalachian range. Despite large geographic difference, the VT site was most closely related to the location furthest from it, SO, also within the Appalachians. Thus, in conjunction with the mitochondrial results showing strong influence of native red foxes throughout the east coast (Kasproicz et al 2016), the present findings support a southern expansion of native red foxes initiating in northeastern North America.

Although the Appalachians apparently served to facilitate native gene flow, we found no evidence that these mountains served as a barrier to non-native gene flow. For example, the landscape resistance model was not a significant predictor of genetic distance among lowland populations. More directly, the AMOVAs that predicted a division between mountain and lowland populations were not significant and admixture profiles were nearly identical between central latitude sites in and out of the Appalachians. Interestingly, the picture provided by the nuclear genetic analysis in the present study contrasts somewhat with that found based on mitochondrial DNA (Kasproicz et al 2016). This distinctiveness was evident also in a direct comparison of mitochondrial haplotypes compared to admixture profiles (Fig. 8). In particular, the mitochondrial patterns showed a much stronger division between Appalachian and lowland, human-dominated landscapes. One of the implication of these findings taken together is that male-mediated gene flow is primarily responsible for the admixture of nonnative and native populations. This has also been found in other nonnative red fox metapopulations, which show much greater structure in mitochondrial than nuclear markers (Sacks et al in review).

However, it is unclear to what extent the homogenization was driven by native gene flow into the lowlands versus nonnative gene flow into the Appalachians. More importantly, we were

unable to identify the relative contribution from European versus fur-farm sources of nonnative admixture. A previous survey found European red fox Y chromosomes to be an order of magnitude less prevalent than European red fox mtDNA haplotypes in the eastern United States (Kasprowicz et al 2016), which implied either selection against European Y chromosomes (or males) or selection for European mitochondria. Thus, it remains unclear the extent to which European red fox nuclear ancestry has infiltrated eastern North American red fox populations. Given the recent evidence for species-level divergence between North American and European red foxes, this question remains important to address in future studies (Statham et al 2014). In particular, identification of diagnostic autosomal nuclear alleles (e.g., SNPs, microsatellites) would enable quantification of European admixture in eastern and other North American red fox populations.

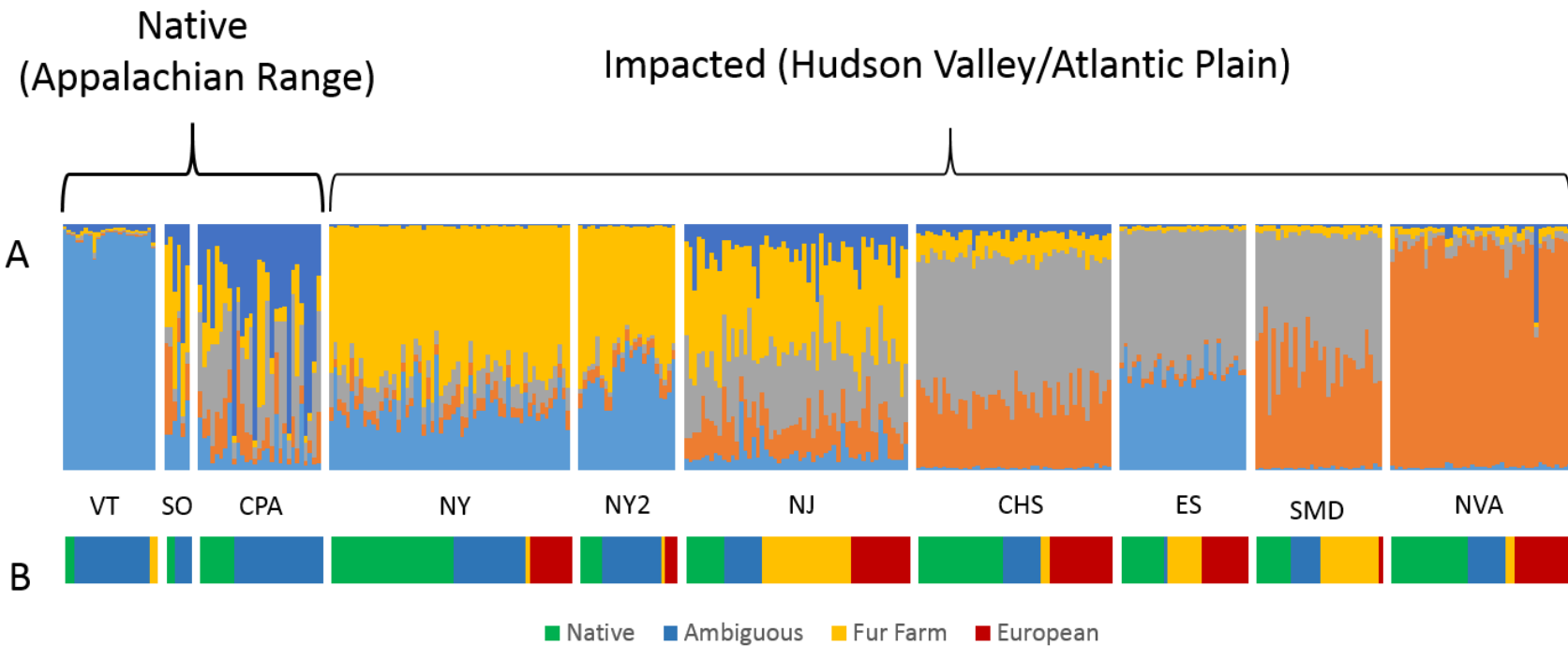

Figure 8 Bar plots from A) microsatellite STRUCTURE analysis at $K = 5$ using the Location prior and corresponding B) mitochondrial haplotypes for each sampling location, color coded in terms of origin from native, fur-farm, ambiguous (native or fur-farm), or European source based on genotypes of 342 red foxes sampled in the eastern United States 2011–2013. Groupings have been rearranged from previous figures to highlight the mitochondrial differentiation.

CONCLUSIONS

We suggest that the most parsimonious explanation to explain the sum total of our findings is the following scenario: red foxes were absent south of New England at the time of European colonization and, because of this vacuum, and changes in the colonial landscape (e.g., removal of wolves, reduction of gray-fox favored habitat, climatic cooling), native red foxes expanded south along the Appalachian Range. It is unclear to what extent the admixture evident in contemporary eastern red foxes, both in the Appalachians and in the Atlantic coastal plain, reflects European versus fur-farm admixture. Regardless, however, the relatively wide contemporary hybrid swarm stands in contrast to the narrow hybrid zones observed when nonnative foxes come into contact with long-established native populations (e.g., Sacks et al 2011), which appears to describe well the interface between the recently formed hybrid swarm and the New England (represented in our study by VT) native population. In the future, identification of specific nuclear alleles from the putative source populations in eastern Canada and Great Britain would enable a clearer understanding of the relative movements of native American versus European genes across the eastern landscape.

ACKNOWLEDGMENTS

We would like to thank M. J. Statham and many interns in the Mammalian Ecology and Conservation Unit of the Veterinary Genetics Laboratory at UC Davis for technical support.

LITERATURE CITED

- ALLEN, S.H. AND A.B. SARGEANT. 1993. Dispersal patterns of red foxes relative to population. *The J Wildlife Manage*, 57: 526-533.
- ALLENDORF, F.W. AND L. L. LUNDQUIST. 2003. Population biology, evolution, and control of invasive species. *Conserv Biol*, 17: 24-30.
- AUBRY, K. B., M. J. STATHAM, B. N. SACKS, J. D. PERRINE, AND S. M. WISELY. 2009. Phylogeography of the North American red fox: vicariance in Pleistocene forest refugia. *Mol Ecol*, 18: 2668-86.
- AVISE, J.C, ARNOLD, J., BALL, M., BERMINGHAM, E., LAMB, T., NEIGEL, J.E., REEB, C. A., AND N.C. SAUNDERS. 1987. Intraspecific Phylogeography: Mitochondrial DNA bridge between population genetics and systematics. *Annu Rev of Ecol Syst*, 18: 489-522.
- AVISE, J.C. AND D. ELLIS. 1986. Mitochondrial DNA and the evolutionary genetics of higher animals. *Philos T Roy Soc B*, 312: 325-342.
- CHURCHER, C. S., 1959. The Specific Status of the New World Red Fox. *J Mammal*, 4: 513-520.
- COBBEN, M.M.P., VERBOOM, J., OPDAM, P.F.M., HOEKSTRA, R.F., JOCHEM, R., AND M.J.M. SMULDERS. 2015. Spatial sorting and range shifts: Consequences for evolutionary potential and genetic signature of a dispersal trait. *J Theor Biol*, 373: 92-99.
- CURAT, M., RUEDI, M., PETIT, R. J. AND L. EXCOFFIER. 2008. The hidden side of invasions: massive introgression by local genes. *Evolution*, 62: 1908-1920
- DARLING, J.C., BAGLEY, M.J., ROMAN, J., TEPOLT, C. K. AND J.B. GELLER. 2008. Genetic patterns across multiple introductions of the globally invasive crab genus *Carcinus*. *Mol Ecol*, 17: 4992-5007.
- DUPANLOUP, I., SCHNEIDER, S., AND L. EXCOFFIER. 2002. A simulated annealing approach to define the genetic structure of populations. *Mol Ecol*, 11: 2571-2581.
- EVANNO, G., REGNAUT, E., AND J. GOUDET. 2005. Detecting the number of clusters of individuals using the software STRUCTURE: a simulation study. *Mol Ecol*, 14: 2611-2620
- EXCOFFIER, L. 2004. Patterns of DNA sequence diversity and genetic structure after a range expansion: lessons from the infinite-island model. *Mol Ecol*, 13: 853-864.
- EXCOFFIER L, AND H. E. L. LISCHER. 2010. ARLEQUIN suite ver 3.5: A new series of programs to perform population genetics analyses under Linux and Windows. *Mol Ecol Res* 10: 564-567.

- EXCOFFIER, L AND N. RAY. 2008. Surfing during population expansions promotes genetic revolutions and structuration. *Ecology and Evolution*, 23: 347-351.
- EXCOFFIER, L., HOFER, R., AND M. FOLL. 2009. Detecting loci under selection in a hierarchically structured population. *Heredity*, 103: 285-298.
- FALUSH, D, STEPHENS, M., AND J.K. PRITCHARD. 2003. Inference of population structure using multilocus genotype data: linked loci and correlated allele frequencies. *Genetics*, 164: 1567-1587.
- FREY, J. K. 2013. Re-evaluation of the evidence for the importation of red foxes from Europe to colonial America: Origins of the southeastern red fox (*Vulpes vulpes fulva*). *Biol Conserv*, 158:74-79.
- GERALDES, A., BASSET, P., GIBSON, B., SMITH, K. L., HARR, B., YU, H. T., AND M.W. NACHMAN (2008). Inferring the history of speciation in house mice from autosomal, X-linked, Y-linked and mitochondrial genes. *Mol Ecol*, 17: 5349-5363.
- GUICHOUX, E., LAGACHE, L., WAGNER, S., CHAUMEIL, P., LÉGER, P., LEPAIS, O., AND R.J. PETIT (2011). Current trends in microsatellite genotyping. *Mol Ecol Res*, 11: 591-611.
- HAGEN, S.B., KOPATZ, A., ASPI, J., KOJOLA, I., AND H. G. EIKEN. 2015. Evidence of rapid change in genetic structure and diversity during range expansion in a recovering large terrestrial carnivore. *P Roy Soc B – Biol Sci*, 282
- HALLATSCHKEK, O. AND D.R. NELSON. 2008. Gene surfing in expanding populations. *Theor Popul Biol*, 73: 158-170.
- HUBISZ, M. J., FALUSH, D., STEPHENS, M., AND J.K. PRITCHARD. 2009. Inferring weak population structure with the assistance of sample group information. *Mol Ecol Res*, 9:1322–32
- KAMLER, J.F. AND W.B. BALLARD. 2002. A review of native and nonnative red foxes in America. *Wildlife Soc B*, 30: 370–379
- KASPROWICZ, A., STATHAM, M., AND B.N. SACKS. 2016. Fate of the other red coat: remnants of colonial British foxes in the eastern United States. *Journal of Mammal*,
- KELKAR, Y. D., STRUBCZEWSKI, N., HILE, S. E., CHIAROMONTE, F., ECKERT, K. A., AND K.D. MAKOVA. 2010. What is a microsatellite: a computational and experimental definition based upon repeat mutational behavior at A/T and GT/AC repeats. *Genome Biology and Evolution*, 2: 620-635
- KOWARIK, I. 2003. On the role of alien species in urban flora and vegetation. *Urban Ecol*. 321-338.
- MAUDET, C., MILLER, C., BASSANO, B., BREITENMOSER-WÜRSTEN, C., GAUTHIER, D., OBEXER-RUFF, G., AND G. LUIKART. 2002. Microsatellite DNA and recent statistical methods in

- wildlife conservation management: applications in Alpine ibex (*Capra ibex ibex*). *Mol Ecol*, 11: 421-436.
- MANTEL, N. 1967. The detection of disease clustering and a generalized regression approach. *Cancer Res*, 27: 209-220.
- MCRAE, B.H., 2006. Isolation by resistance. *Evolution*, 60:1551–61.
- MONA, S., RAY, N., ARENAS, M. AND L EXCOFFIER. 2014. Genetic consequences of habitat fragmentation during a range expansion. *Heredity*, 112: 291-299.
- MOORE, M., BROWN, S.K., AND B.N. SACKS. 2010. Thirty-one short red fox (*Vulpes vulpes*) microsatellite markers. *Mol Ecol Resources*, 10: 404-408.
- NIEDZIAŁKOWSKA, M., HUNDERTMARK, K.J., JĘDRZEJEWSKA, B., NIEDZIAŁKOWSKI, K., SIDOROVICH, V.E., GÓRNY, M., VEEROJA, R., SOLBERG, E.J., LAAKSONEN, S., SAND, H. AND V.A. SOLOVYEV. 2014. Spatial structure in European moose (*Alces alces*): genetic data reveal a complex population history. *J Biogeogr*, 41: 2173-2184.
- OKSANEN, J., BLANCHET, F.G., KINDT, R., LEGENDRE, P., MINCHIN, P.R., O’HARA, R.B., SIMPSON, G.L., SOLYMOS, P., STEVENS, M.H.H. AND H. WAGNER. 2015. vegan: Community Ecology Package. R package version 2.0-10.
- PEAKALL, R. O. D., AND P.E SMOUSE. 2006. GENALEX 6: genetic analysis in Excel. Population genetic software for teaching and research. *Mol Ecol Notes*, 6: 288-295.
- PIMM, S.L., RUSSELL, G. J., GITTLEMAN, J.L. AND T. M. BROOKS. 1995. The future of biodiversity. *Science*, 269: 347-350.
- PRITCHARD, J K, STEPHENS, M & P. DONNELLY. 2000. Inference of population structure using multilocus genotype data. *Genetics*, 155: 945–59.
- RAY, N. AND L. EXCOFFIER. 2010. A first step towards inferring levels of long-distance dispersal during past expansions. *Mol Ecol Res*, 10: 902-914
- RAYMOND, M., & F. ROUSSET. 1995. GENEPOP (version 1.2): population genetics software for exact tests and ecumenicism. *J Hered*, 86: 248-249.
- RICCIARDI, A. 2007. Are modern biological invasions an unprecedented form of global change? *Conserv Biol*, 21: 329-336.
- ROUSSET, F. 2008. genepop’007: a complete re-implementation of the genepop software for Windows and Linux. *Mol Ecol res*, 8: 103-106.

- SACKS, B. N., STATHAM, M. J., PERRINE, J. D., WISELY, S. M. AND K. B. AUBRY. 2010. North American montane red foxes: expansion, fragmentation, and the origin of the Sacramento Valley red fox. *Conserv Genet*, 11:1523–1539.
- SACKS, B. N., MOORE, M., STATHAM, M. J., AND H. U. WITTMER. 2011. A restricted hybrid zone between native and introduced red fox (*Vulpes vulpes*) populations suggests reproductive barriers. *Mol Ecol*, 20:326–341.
- SACKS, B.N., BRAZEAL, J.L., AND J.C. LEWIS. In review. Anatomy of a mammalian invasion: the nonnative red fox in California.
- SAKAI, A. K., ALLENDORF, F. W., HOLT, J. S., LODGE, D. M., MOLOFSKY, J., WITH, K. A. AND D.E. MCCAULEY. 2001. The population biology of invasive species. *Annu Rev Ecol Syst*, 305-332.
- SCHREY, A. W., LIEBL, A. L., RICHARDS, C. L., AND L.B. MARTIN. 2014. Range expansion of house sparrows (*Passer domesticus*) in Kenya: evidence of genetic admixture and human-mediated dispersal. *J Hered*, 105: 60-69.
- SHAH, V. B., AND B. H. MCRAE. 2008. Circuitscape: a tool for landscape ecology. *Proceedings of the 7th Python in Science Conference*, 7: 62-66.
- SLATKIN, M., AND L. EXCOFFIER. 2012. Serial founder effects during range expansion: a spatial analog of genetic drift. *Genetics* 191: 171-181.
- SZPIECH, Z.A., JAKOBSSON, M., AND N. ROSENBERG. 2008. ADZE: a rarefaction approach for counting alleles private to combinations of populations. *Bioinformatics*, 24: 2498-2504.
- STATHAM, M. J., SACKS, B. N., AUBRY, K. B., PERRINE, J. D. AND S. M. WISELY. 2012. The origin of recently established red fox populations in the United States: translocations or natural range expansions? *J Mammal*, 93:52–65.
- TOEWS, D. P., AND A. BRELSFORD. 2012. The biogeography of mitochondrial and nuclear discordance in animals. *Mol Ecol*, 21: 3907-3930.
- TOONEN, R. J., AND S. HUGHES. 2001. Increased throughput for fragment analysis on ABI prism 377 automated sequencer using a membrane comb and STRand software. *Biotechniques* 31:1320–1324.
- WANDELER, P., FUNK, S. M., LARGIADER, C. R., GLOOR, S., AND U. BREITENMOSER. 2003. The city-fox phenomenon: genetic consequences of a recent colonization of urban habitat. *Mol Ecol* 12, 647–656.

Appendix 1 Locus specific F_{IS} by population and loci not meeting Hardy Weinberg Expectations at the $p < 0.05$ level based on genotypes of 342 red foxes sampled in the eastern United States 2011–2013.

	CHS	CPA	ES	NJ	NVA	NY1	NY2	SMD	SO	VT	Mean	
	F_{IS}	F_{IS}	F_{IS}	F_{IS}	F_{IS}	F_{IS}	F_{IS}	F_{IS}	F_{IS}	F_{IS}	F_{IS}	SE
AHT140	-0.031	-0.188	0.126	-0.089	-0.007	-0.101	-0.034	0.012	0.345	-0.026	0.001	0.046
c01.424PET	-0.131	0.077	0.284*	0.139	-0.056	-0.162	-0.123	0.125	0.355	-0.173	0.034	0.060
FH2004	0.056	-0.192	0.112	0.151	-0.138	0.165	-0.091	-0.242	0.172	-0.037	-0.004	0.049
FH2010	-0.049	0.158	-0.035	0.033	-0.101	0.001	-0.043	0.004	0.143	-0.150	-0.004	0.031
FH2088	0.125	0.188	0.171	0.354*	0.103	0.098*	0.127	-0.041	-0.091	0.256	0.129	0.041
FH2289	0.152	-0.055	0.028	0.159	0.052	0.002	0.129	0.033	-0.714	-0.146	-0.036	0.081
FH2380	-0.105	-0.083	0.038	-0.018	0.160	-0.075	0.203	-0.029	-0.429	0.237	-0.010	0.061
AHT133	0.027	0.057	0.133*	0.104*	0.071	0.135	-0.159	0.093	-0.297	-0.129	0.003	0.046
FH2328	0.024	0.010	0.009	-0.039	0.021	0.044	-0.017	0.159	-0.180	-0.003	0.003	0.026
RF08.618	-0.081	0.129	0.065	0.049	-0.001	0.048	0.187	0.235	-0.154	-0.060	0.042	0.038
RF2001Fam	0.093	-0.030	0.192	0.058*	-0.070*	0.032	-0.030	-0.002	0.265	-0.019	0.049	0.034
RF2054	0.133	-0.211	0.015	0.095	0.002	0.081	-0.047	0.094	-0.034	0.057	0.019	0.032
RF2457	-0.018	-0.198	0.134	0.005*	0.060*	0.028	0.116	-0.005	-0.286	-0.037	-0.020	0.041
RFCPH2	-0.026	-0.037	-0.055	0.038	0.154	-0.002	-0.008	-0.004	0.172	-0.055	0.018	0.026
AHT171	0.064	0.205	0.252*	-0.081	-0.211	-0.078	0.054	-0.023	-0.538	0.040	-0.032	0.071
CPH11	-0.075	0.093	-0.076	0.036	-0.089	0.088	-0.219	0.327	0.467	0.174	0.073	0.066
CPH18	-0.049*	-0.046	0.113	-0.025	-0.045	-0.048	-0.051	-0.232	-0.333	-0.114	-0.083	0.039
CXX-468	0.132	0.048	-0.072	0.027	-0.053	0.033	0.049	-0.140	-0.200	-0.065	-0.024	0.032
CXX-602	0.009	-0.018	0.278*	0.023	0.244	-0.051	0.000	-0.070	-0.067	-0.011	0.034	0.039
FH2848	0.008*	-0.071	0.032	0.007	0.004	-0.010	-0.039	0.141	-0.067	0.124	0.013	0.023
REN54P11	0.242*	0.060	0.108	-0.035	-0.058	0.119	-0.005	0.162	-0.154	0.035*	0.047	0.037
Average	0.024	0.026	-0.001	0.059	0.044	-0.002	-0.032	0.013	-0.077	-0.005	0.005	
SE	0.021	0.031	0.027	0.017	0.031	0.018	0.030	0.018	0.067	0.026	0.010	

* $p < 0.05$

Chapter 4

The extent of European introgression in native red fox populations based on nuclear markers.

INTRODUCTION

Hybridization is often a natural event in the history of interactions among species. It is not natural, though, when these events are caused by humans through habitat modifications, climate change, and translocations (Wilson et al 2009; Kovach et al 2015). In these scenarios, there is considerable concern that native species will be deleteriously impacted (Kovach et al 2015) so studying the dynamics of an introduced species and its interactions with previously isolated populations provide opportunities to study introgression and admixture (Sax et al 2007; Darling et al 2014). A major concern with introgression is that it is asymmetrical and it will lead to the invasive or introduced population genetically swamping the native resulting in a loss of unique genetic diversity or even genetic extinction (Orive and Barton 2002; Nussberger et al 2014). Introgression can also result in the extinction of local genotypes, loss of local adaptation, and homogenization of species (Kovach et al 2015). The concern is heightened when the source is anthropogenic where gene flow from a domestic population can affect the fitness of wild populations (Kidd et al 2009). However, admixture may have a positive impact through restoration of genetic variation, increase of genetic variation, creation of novel genotypes, and heterosis (Bermond et al 2012). In addition, the impact of invaders on native genomes may be overstated. Recent studies have shown that local species have the upper-hand when it comes to nuclear introgression. In a series of simulation studies, Currat et al (2008) demonstrated that nuclear introgression will occur almost exclusively in the direction of native to invader with the result that the invaders genome becomes swamped and eventually eliminated in the admixed population.

Red foxes (*Vulpes vulpes*) are a geographically diverse taxon, present natively across the Northern hemisphere. Statham et al (2014) suggest European and North American red foxes

could be distinct species based on global analyses of genetic markers. This and other large scale analyses based on nuclear and mitochondrial data show they are distinct, falling into separate clades within a global framework (Aubry et al 2009; Statham et al 2014). Morphologically and behaviorally red foxes are diverse but North American red foxes, in particular, show an affinity for boreal habitats while Eurasian red foxes occur in a much wider range of habitats, including deserts.

British red foxes were introduced to the eastern United States at a time when native foxes were expanding south from populations in eastern Canada (Kasprowicz et al 2016). This artificially created an area of secondary contact between North American and Eurasian red foxes. Although European haplotypes were found to be absent from most of contemporary North America (Statham et al 2012), a previous study found 2 British mitochondrial haplotypes at relatively high frequency (~30%) in a small region of the eastern United States near where they had been introduced a couple centuries earlier (Kasprowicz et al 2016). Despite the geographic restriction of these British haplotypes to a relatively small area, analysis of neutral nuclear markers showed little population differentiation between this and neighboring regions that had no British mtDNA haplotypes (Kasprowicz and Sacks 2016). Similarly, only 3 instances of a British Y chromosome were found in the Eastern United States, suggesting asymmetry in the introgression of British mitochondrial and nuclear genes.

Organelle genomes, such as mtDNA, move readily across species barriers due to their “introgressive advantages” resulting from their haploid nature, maternal inheritance, small genome size, and the reduced impact of selection (Abe et al 2005; Currat et al 2008). The near-absence of European Y-chromosomal markers in North American red foxes suggest some level

of reproductive isolation, possibly related to Haldane's rule (Statham et al 2014; Kasproicz et al 2016).

Secondary contact provides an opportunity to study admixture, expansion, and speciation. Here, we use microsatellite markers from parent populations as well as the region of admixture to examine the level of introgression between fox lineages. Our primary objective was to identify the nuclear origins of red foxes in the mid-Atlantic region. To accomplish this, we compared genetic data from the area of admixture to data from two potential sources, populations in eastern Canada and Great Britain. Additionally, previous analyses have confirmed that British red foxes have impacted certain regions but overall low levels of population structure throughout the region of admixture suggests that the impact of British nuclear genome may be less widespread. We compared *a priori* hypotheses incorporating data from the potential source populations and based on geographic and mitochondrial groupings that upland, Appalachian populations are primarily native while lowland populations have strong British influence.

METHODS

Sampling

We used 342 red fox samples from 7 states across the mid-Atlantic region of the United States previously described in Kasproicz and Sacks (2016). In addition, we included 50 samples from Great Britain and 68 from eastern Canada in the collection at the Mammalian Ecology and Conservation Unit of the Veterinary Genetics Laboratory at the University of California-Davis (Lounsberry et al *in prep*; Statham et al *in prep*). All samples used in this study have been archived in the same collection. Samples from the United States (USA) were divided

into sub-groups based on the region in which they were collected: Chesapeake region including northern Maryland and southern Pennsylvania (CHS), eastern shore from Delaware (ES), western New York (NY), southern Maryland (SMD), northern Virginia (NVA), northern New Jersey (NJ), central Pennsylvania (CPA), and the southern Appalachians in Virginia and North Carolina (SO).

Genotyping

We genotyped all 464 individuals at 21 microsatellite loci. Amplification protocols can be found in Kasprovicz and Sacks (2016). Alleles presumed to display size homoplasy between native and introduced lineages were treated ambiguously and coded as the same allele size for both lineages.

Population Statistics

We used GenePop v 4.4 to test for linkage disequilibria among loci and deviations from Hardy-Weinberg Equilibrium and estimate F_{IS} (Rousset 2008). All statistical analyses were tested for significance against an alpha value of $p = 0.05$. We calculated expected and observed heterozygosities (H_E and H_O), number of alleles (n_a), and private alleles in GenAlEx (Peakall and Smouse 2006). We used ADZE-1.0 to create rarefaction curves for allelic richness (A_R) and private allelic richness (pA_R) standardized to $n = 50$ (Szpiech et al 2008). We performed an AMOVA based on F_{ST} and Nei's Genetic Distance (unbiased; 1978) with 999 iterations in GenAlEx using the three major geographical groupings: Great Britain and Ireland (GB), Newfoundland in Eastern Canada (CAN), and Mid-Atlantic (USA).

Source of nuclear genome

We compared four hypotheses on the origins of the mid-Atlantic populations using AMOVAs in Arlequin (Excoffier et al 2005). The first two hypotheses addressed the relationship between USA and each potential source population to identify which one was the parent: USA vs. GB, and USA vs. CAN. Hypotheses three and four were focused on the distribution of the individual USA sampling regions in relation to overall populations and the impact of the different source populations on each. The third hypothesis paired populations that had mitochondrial evidence of British introductions (CHS, ES, NY, SMD, NVA, NJ) with the GB samples and those that had native mitochondrial genomes (VT, CPA, SO) with the CAN samples. Significant differentiation among the regions would support the British influence in the nuclear genome. Finally, we separated the USA into sampling locations and tested the hypothesis that mountain populations were derived from CAN sources while the lowland populations were derived from GB sources. We previously identified the differentiation between mountain and lowland populations through mitochondrial (Kasprowicz et al 2016) and nuclear markers (Kasprowicz and Sacks 2016) though we could not definitively link the nuclear differentiation to British sources. The incorporation of samples from Great Britain allows us to resolve this problem.

Introduced Admixture

Finally, we wanted to determine to what extent nuclear introgression had occurred in the USA samples. We used STRUCTURE 2.3.3 to analyze genetic structuring within and among populations (Pritchard et al 2000). We used the admixture model because it is more powerful in detecting potential hybridization, and correlated allele frequency model because the relaxed prior

is more appropriate for evolutionary inferences (Falush et al 2003). We used a burn-in of 250,000 followed by 750,000 Markov chain Monte Carlo simulations. We set $K = 2$ and $K = 3$ in separate analyses and ran 10 iterations to explore relationships between the three populations with and without the location prior. We separated hybrids using the admixture proportion of each individual q_i as an estimate of an individual's proportion of ancestry from each of the clusters (Primmer 2006). We chose a conservative threshold value of $q = 0.20 - 0.80$ for hybrid detection because values outside this range tended to detect hybrids even in purebred populations (Sacks et al 2011). In addition, we performed analyses at higher levels of K to explore additional potential levels of structure. We repeated the above analyses run 10 iterations at each value of $K = 2 - 11$.

RESULTS

Summary Statistics

Significant LD was observed in four microsatellite locus-pairs in USA and two different locus-pairs in GB but none in CAN. Two loci deviated significantly from HWE in all three (GB, CAN, USA) populations, CPH18 and RF2457. Allelic richness was greatest for GB followed by USA then CAN (8.00, 6.42, 5.82, respectively). Private allelic richness was almost four times greater in GB than in USA or CAN (2.40, 0.66, 0.56). Heterozygosity, both observed and expected, was highest in the USA population (Table 1).

Table 1: Population statistics for pooled populations: Great Britain and Ireland (GB), eastern Canada (CAN), and eastern United States (USA). Presented are the number of individuals (N), inbreeding coefficient (F_{IS}), expected and observed heterozygosity (H_E , H_O), allelic richness (A_R), and private allelic richness (pA_R) both with variance in parentheses. Allelic richness and private allelic richness were standardized for $n = 50$.

	N	F_{IS}	H_E	H_O	A_R	pA_R
USA	342	0.063	0.715	0.670	6.42 (4.16)	0.66 (0.46)
CAN	68	0.225	0.665	0.606	5.82 (6.17)	0.56 (0.81)
GB	50	0.089	0.697	0.541	7.99 (13.3)	2.40 (3.95)

Table 2: Pairwise comparisons for pooled USA populations: Great Britain and Ireland (GB), eastern Canada (CAN), and eastern United States (USA), including F_{ST} (below diagonal) and Nei's genetic distance (above diagonal). Asterisk (*) indicates significant comparison ($P < 0.05$) based on 999 permutations.

	USA	CAN	GB
USA	-	0.279	0.410
CAN	0.095*	-	0.678
GB	0.119*	0.185*	-

Genetic structure and differentiation

The AMOVA revealed 80% of variation was within individuals while only 11% could be explained by difference among populations. When the USA population was analyzed as its component populations, variation among these populations only accounted for 3% of the total variation. Global F_{ST} was 0.112 and significant. Levels of differentiation among all populations were high and significant, with the highest differentiation estimated between GB and CAN ($F_{ST} = 0.185$; Nei's $G_{ST} = 0.678$; Table 2). When comparing GB and CAN to individual USA populations, GB was most differentiated from VT and in general has lower F_{ST} values when compared with mid-Atlantic populations (Table 3). All USA populations were also strongly differentiated from CAN though less so than from GB excluding CHS which was less differentiated from GB than CAN ($F_{ST} = 0.113$ vs $F_{ST} = 0.150$; Table 3). While all of the a

priori AMOVA's were significant, the highest support came from grouping the USA sample sites with the CAN population (Table 4), suggesting that GB had little influence on the genomic make-up of USA foxes. On the other hand, we found the second most support for the hypothesis that grouped the USA sampling sites with British mtDNA with GB vs. grouping the USA sampling sites with no British mtDNA with CAN sites. This comparison was considerably better supported than the comparison which grouped USA sampling sites according only to whether they were in the Appalachians or not. Taken together, the trend suggests some correspondence between the relative proportions of British nuclear DNA and mtDNA among sampling sites.

The focus of this study was to determine the level of admixture in USA populations. As such, we focused analysis on $K = 2$ and $K = 3$, to quantify the contribution of each 'parent population' to the USA populations. Structure analysis showed the USA population clustering with CAN at $K = 2$, but separating at $K = 3$ (Fig 1) demonstrating the structure is hierarchical such that the magnitude of differentiation between USA and CAN is less than the degree of differentiation of either from GB. At $K = 3$ only 14 individuals met the threshold for hybrid.

Table 3: Pairwise population comparisons, linearized F_{ST} (below diagonal) and Nei's unbiased genetic distance (above diagonal), among Great Britain and Ireland (GB), eastern Canada (CAN), and subsamples of the eastern United States (USA): Vermont (VT), New York (NY), New Jersey (NJ), central Pennsylvania (CPA), Chesapeake (CHS), Eastern Shore/Delmarva Peninsula (ES), southern Maryland (SMD), northern Virginia (NVA), and southern Virginia (SO).

	GB	CAN	VT	SO	CPA	NY	NJ	CHS	ES	SMD	NVA
GB	-	0.014	0.029	0.052	0.141	0.086	0.047	0.279	0.092	0.075	0.230
CAN	0.007	-	0.008	0.047	0.135	0.067	0.043	0.302	0.077	0.055	0.215
VT	0.012	0.004*	-	0.055	0.116	0.049	0.042	0.266	0.054	0.063	0.190
SO	0.025*	0.020	0.020*	-	0.160	0.076	0.063	0.318	0.100	0.038	0.253
CPA	0.051	0.049	0.020	0.050	-	0.163	0.147	0.031	0.195	0.170	0.301
NY	0.030	0.024	0.016	0.018	0.052	-	0.073	0.337	0.051	0.078	0.095
NJ	0.018	0.017	0.015	0.021	0.051	0.025	-	0.330	0.064	0.082	0.194
CHS	0.102	0.107	0.097	0.114	0.014	0.108	0.051	-	0.195	0.353	0.499
ES	0.034	0.030	0.020	0.034	0.065	0.017	0.023	0.137	-	0.085	0.142
SMD	0.028	0.023	0.025	0.011*	0.060	0.027	0.031	0.122	0.031	-	0.225
NVA	0.072	0.070	0.057	0.066	0.087	0.029	0.061	0.143	0.045	0.071	-

* $p > 0.05$

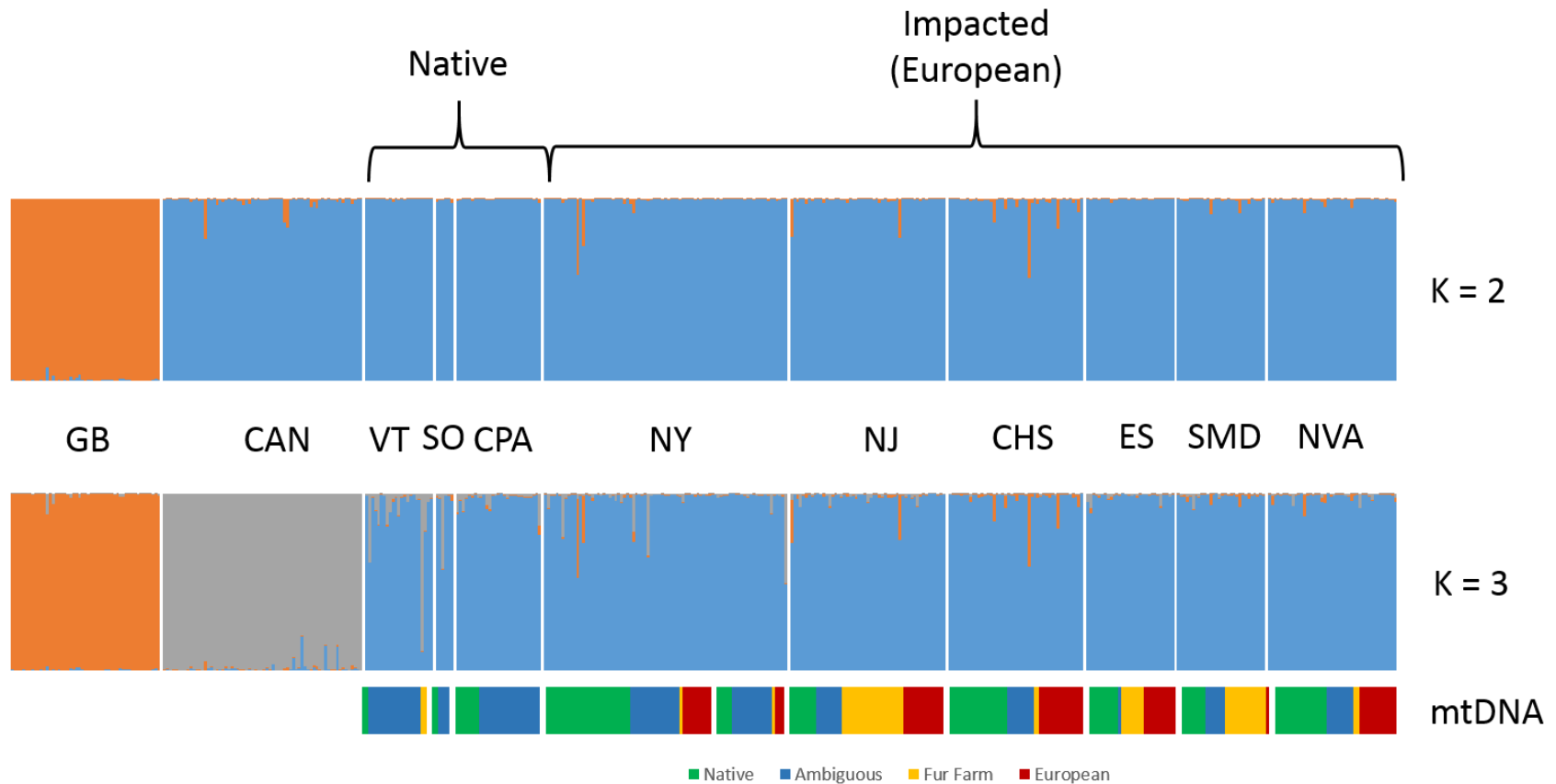

Figure 1: Bar plots based on Structure results for $K = 2$ and $K = 3$ among the three pooled populations: Great Britain and Ireland (GB), eastern Canada (CAN), and eastern United States (Vermont (VT), New York (NY), New Jersey (NJ), central Pennsylvania (CPA), Chesapeake (CHS), Eastern Shore/Delmarva Peninsula (ES), southern Maryland (SMD), northern Virginia (NVA), and southern Virginia (SO)). Brackets identify the USA populations that have remnant European mitochondrial DNA (impacted) versus those with haplotypes native to North America. Similarly, a bar plot identifying the mitochondrial haplotype of each of the individuals within the USA population is below. Green represents native mtDNA, blue is ambiguously native (may be from fur farm), yellow is unambiguously fur farm, and red is European.

Three populations, CHS, NJ, and NY, each had two individuals that had significant proportions of both USA and GB ancestry. Meanwhile, four locations had USA/CAN mixtures: 4 in NY, 1 in CPA, 1 in SO, and 2 in VT (Table 5). As expected, there were no mixed individuals in either ‘parent’ population. Finally, VT had one individual that was assigned to the CAN cluster with a q-value higher than 0.80.

Table 4: Hypothesis based AMOVA’s comparing relatedness among populations, Great Britain and Ireland (GB), eastern Canada (CAN), and eastern United States (USA). Subsamples of the eastern USA include Vermont (VT), New York (NY), New Jersey (NJ), central Pennsylvania (CPA), Chesapeake (CHS), Eastern Shore/Delmarva Peninsula (ES), southern Maryland (SMD), northern Virginia (NVA), and southern Virginia (SO).

		F _{ST}	F _{SC}	F _{CT}
USA/GB	1: USA, GB 2: CA	0.107*	0.121*	-0.015
USA/CAN	1: USA, CAN 2: GB	0.131*	0.096*	0.039*
European mtDNA	1: USA (CHS, ES, NY, SMD, NVA, NJ), GB 2: USA (VT, CPA, SO), CAN	0.093*	0.069*	0.026*
Mountain/Valley	1: CAN, USA (VT, NJ, NVA, CPA, SO) 2: GB, USA (NY, CHS, ES, SMD, NJ)	0.081*	0.078*	0.002

* $p < 0.05$

As K was increased, clusters emerged among the USA populations, consistently separating out VT and NVA from the rest. A full analysis setting $K = 1 - 10$ suggested $K = 3$ as the most likely value of K based on both the Pritchard $P(X|K)$ and the Evanno ΔK method (Fig. 2; Pritchard et al 2000; Evanno et al 2005). We present $K = 4-7$ to demonstrate how substructure increases in the colonial populations but not source populations (Fig. 3). As the number of clusters allowed (K) increases, the individuals assigned to these additional genetic groupings are almost exclusively in the colonial populations, while the source populations.

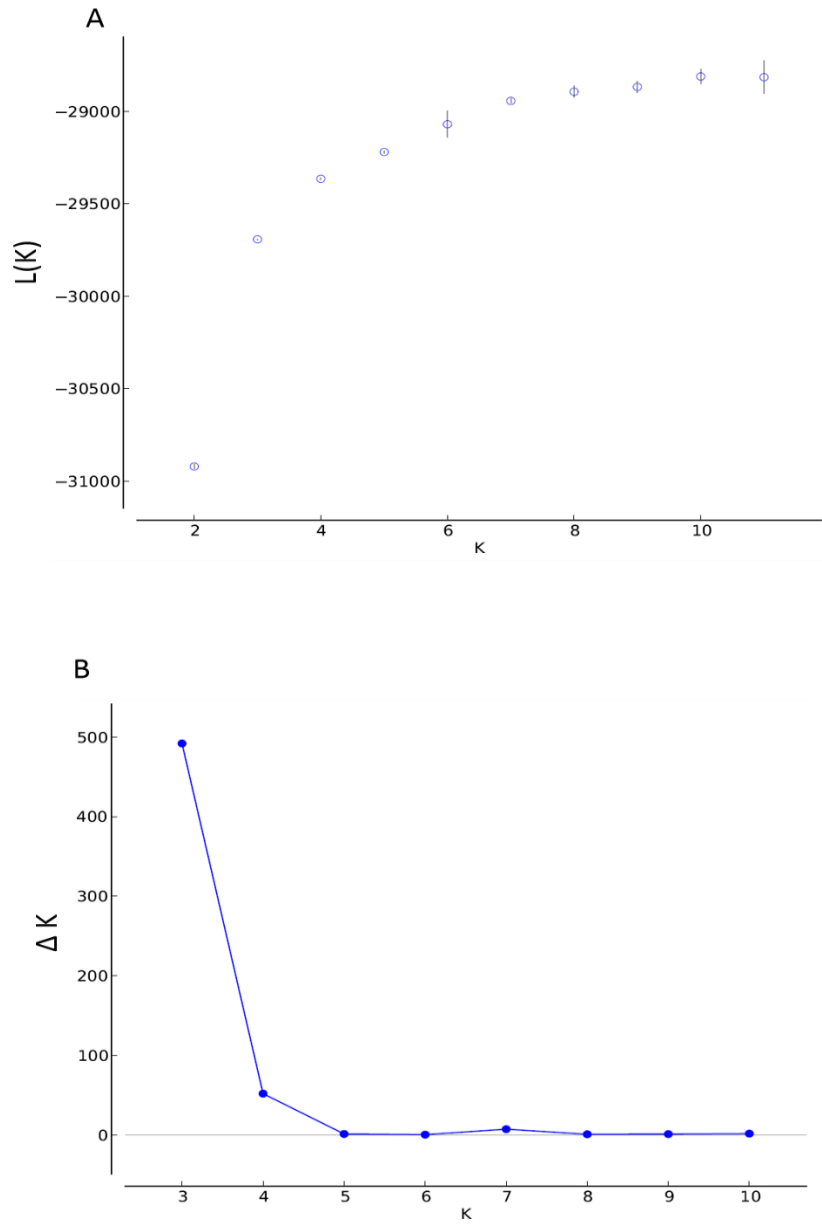

Figure 2: Graphs to determine optimal value of clusters (K) under the (A) Pritchard model using likelihoods and (B) Evanno et al (2005) method that calculates ΔK .

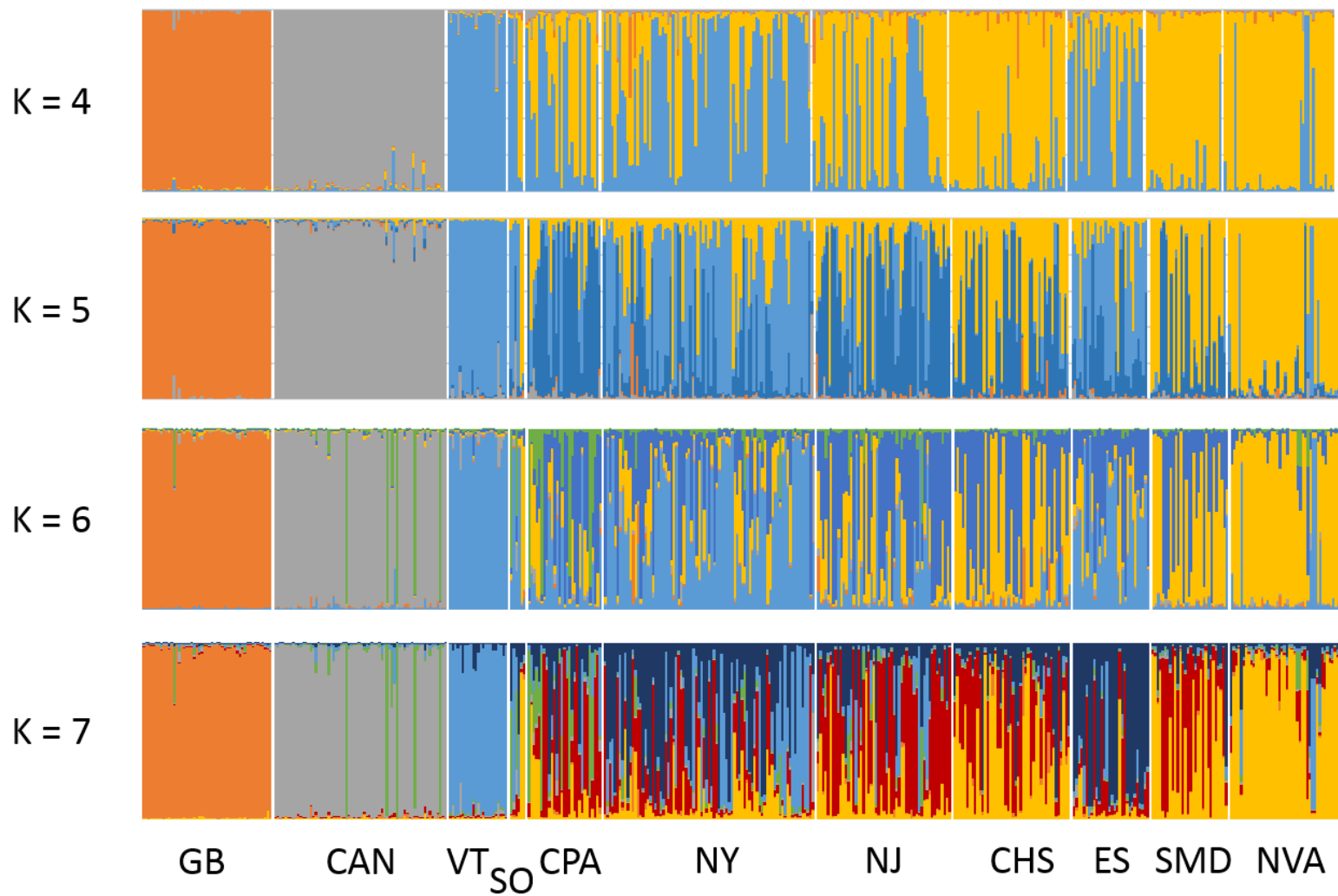

Figure 3: Bar plots representing $K = 4 - 7$ for the populations: Great Britain and Ireland (GB), eastern Canada (CAN), and eastern United States (Vermont (VT), New York (NY), New Jersey (NJ), central Pennsylvania (CPA), Chesapeake (CHS), Eastern Shore/Delmarva Peninsula (ES), southern Maryland (SMD), northern Virginia (NVA), and southern Virginia (SO)).

Table 5: Number of hybrid individuals ($0.8 < q < 0.2$) within each sample location: Great Britain and Ireland (GB), eastern Canada (CAN), Vermont (VT), New York (NY), New Jersey (NJ), central Pennsylvania (CPA), Chesapeake (CHS), Eastern Shore/Delmarva Peninsula (ES), southern Maryland (SMD), northern Virginia (NVA), and southern Virginia (SO).

	K = 3		
	K=2	USA/GB	US/CAN
GB	0	0	0
CAN	1	0	0
VT	0	0	2
SO	0	0	1
CPA	0	0	1
NY	2	2	4
NJ	2	2	0
CHS	1	2	0
ES	0	0	0
SMD	0	0	0
NVA	0	0	0

DISCUSSION

Our results show that, although introduced mitochondrial lineages are present in high frequency, there is little evidence of nuclear genes from British red foxes. There is support, based on our nuclear data, of the influence introduced markers have had in increasing the genetic diversity of the USA populations, resulting in increased differentiation with CAN population. This could also be explained by isolation by distance from a more remote north eastern population. However, rather than having reduced genetic variation as often expected with IBD, the USA population has higher heterozygosity and average allelic richness. Nevertheless, the impact has not been as significant as that of the mitochondrial genome. Mito-nuclear discordance, when mtDNA and msat markers have different coalescent signals, is a common occurrence in animal systems (Toews and Brelsford 2012). Similar to our findings, there is usually more structuring in the mitochondrial DNA. There are several explanations for this including coalescent variance, selective sweeps, life history traits, and modes of molecular inheritance (Pavlova et al 2012).

The explanation for our results comes from theoretical predictions about admixture between two previously isolated populations. Contrary to prior thinking, nuclear introgression between two previously isolated populations that are still reproductively compatible is expected to occur in the direction of native into introduced (Currat et al 2008). Based on the relatedness between the red foxes in the United States and those in Canada and the UK, it is clear that the native genome persists. There is strong support that the US populations are derived from eastern Canada based on nuclear markers. The only exception, CHS, has a high proportion of mitochondrial British markers and could represent an area where introductions occurred.

A second prediction from Currat et al (2008) is that higher introgression would occur among markers of the less dispersing sex because of reduced conspecific gene flow at the expansion front. This would likely result in the lower effective population size and higher rate of introgression (Nussberger et al 2014). This is because as those genes disperse into the native range, backcrossing is exclusively with the natives and eventually those markers are swamped. With the least dispersing sex, however, as hybridization occurs there's continuous backcrossing with the invasive population that is exponentially growing. The non-dispersing genes increase under genetic drift and gradually introgress into the native population. In our case, mitochondrial DNA from British ancestors was able to migrate as far inward as western New York, probably around the Appalachian Mountain range through the human-dense Hudson River Valley. While the dispersal there may have been the result of human transport, there is evidence for ongoing gene flow between the populations. Contrastingly, we identified only three European Y markers, and those were all in the Chesapeake Bay watershed region (Kasprowicz et al 2016). Although red foxes have a broad range of behavioral phenotypes when it comes to dispersal and mating, typically males have a higher rate of dispersal (Allen and Sargeant 1993).

A second explanation, though not mutually exclusive, for the strong presence of invasive mtDNA but not Y markers is Haldane's rule, "when in the offspring of two different animal races one sex is absent, rare, or sterile, that sex is the [heterogametic] sex" (Haldane 1922). In other words, when two species hybridize, heterogametic offspring will be less viable. In this case, male hybrid offspring are less viable than female offspring resulting in the continuance of European mitochondrial genome but not the Y genome.

It is generally accepted at this point that phylogenetic studies should be completed with multiple types of markers, as different markers can provide different insight. For example, markers associated with the most dispersing sex are expected to be better at delimiting species because they experience higher levels of gene flow (Petit and Excoffier 2009). In this case, while mitochondrial markers may provide greater insight into the history of red foxes in the mid-Atlantic United States, the Y markers reveal the current reality: introduced British red foxes have had little impact on the population and the remnants of the introductions will likely be lost over time.

LITERATURE CITED

- ABE, T. A., SPENCE, J. R., AND F. A. SPERLING. 2005. Mitochondrial introgression is restricted relative to nuclear markers in a water strider (Hemiptera: Gerridae) hybrid zone. *Canadian Journal of Zoology*, 83: 432-444.
- ALLEN, S.H. AND A.B. SARGEANT. 1993. Dispersal patterns of red foxes relative to population. *The Journal of Wildlife Management*, 57: 526-533.
- AUBRY, K. B., M. J. STATHAM, B. N. SACKS, J. D. PERRINE, AND S. M. WISELY. 2009. Phylogeography of the North American red fox: vicariance in Pleistocene forest refugia. *Molecular Ecology*, 18: 2668–86.
- BERMOND, G., CIOSI, M., LOMBAERT, E., BLIN, A., BORIANI, M., FURLAN, L., AND T. GUILLEMAUD. 2012. Secondary contact and admixture between independently invading populations of the western corn rootworm, *Diabrotica virgifera virgifera* in Europe. *PloS one*, 7: e50129.
- CURRAT, M., RUEDI, M., PETIT, R. J. AND L. EXCOFFIER. 2008. The hidden side of invasions: massive introgression by local genes. *Evolution*, 62: 1908-1920.
- DARLING, J. A., TSAI, Y. H. E., BLAKESLEE, A. M., AND J. ROMAN. 2014. Are genes faster than crabs? Mitochondrial introgression exceeds larval dispersal during population expansion of the invasive crab *Carcinus maenas*. *Royal Society Open Science*, 1: 140202.
- EXCOFFIER L, AND H. E. L. LISCHER. 2010. ARLEQUIN suite ver 3.5: A new series of programs to perform population genetics analyses under Linux and Windows. *Molecular Ecology Resources* 10: 564–567.
- FREY, J. K. 2013. Re-evaluation of the evidence for the importation of red foxes from Europe to colonial America: Origins of the southeastern red fox (*Vulpes vulpes fulva*). *Biological Conservation* 158:74-79.
- HALDANE, J. B. 1922. Sex ratio and unisexual sterility in hybrid animals. *Journal of genetics*, 12: 101-109.
- KASPROWICZ, A.E, STATHAM, M., AND B.N. SACKS. 2016. Fate of the other red coat: remnants of colonial British foxes in the eastern United States. *Journal of Mammalogy*, 97: 298-309.
- KASPROWICZ, A.E. AND B.N. SACKS. 2016. History of the native red fox in eastern United States: Identifying the impacts of spatial expansion and translocation on the structure of a mobile generalist. *Conservation Genetics*, In Review.
- KIDD, A. G., BOWMAN, J., LESBARRERES, D., AND A. I. SCHULTE-HOSTEDDE. 2009. Hybridization between escaped domestic and wild American mink (Neovison vison). *Molecular Ecology*, 18: 1175-1186.
- KOVACH, R. P., MUHLFELD, C. C., BOYER, M. C., LOWE, W. H., ALLENDORF, F. W., AND G. LUIKART. 2015. Dispersal and selection mediate hybridization between a native and invasive species. *Proceedings of the Royal Society of London B: Biological Sciences*, 282(1799), 20142454.

- NEI, M. 1978. Estimation of average heterozygosity and genetic distance from a small number of individuals. *Genetics*, 76: 379-390.
- NUSSBERGER, B., WANDELER, P., WEBER, D., AND L. F. KELLER. 2014. Monitoring introgression in European wildcats in the Swiss Jura. *Conservation Genetics*, 15: 1219-1230.
- ORIVE, M.E. AND N. H. BARTON. 2002. Associations between the cytoplasmic and nuclear loci in hybridizing populations. *Genetics*, 162:1469-1485.
- PAVLOVA, A., AMOS, J.N., JOSEPH, L., LOYNES, K., AUSTIN, J.J., KEOGH, J.S., STONE, G. N., NICHOLLS, J.A., AND P. SUNNUCKS. 2013. Perched at the mito-nuclear crossroads: divergent mitochondrial lineages correlate with environment in the face of ongoing nuclear gene flow in an Australian bird. *Evolution*, 67: 3412-3428.
- PEAKALL, R. O. D., AND P.E SMOUSE. 2006. GENALEX 6: genetic analysis in Excel. Population genetic software for teaching and research. *Molecular Ecology Notes*, 6: 288-295.
- PETIT, R. J., AND L. EXCOFFIER. 2009. Gene flow and species delimitation. *Trends in Ecology & Evolution*, 24: 386-393.
- VÄHÄ, J. P., & C.R. PRIMMER. 2006. Efficiency of model-based Bayesian methods for detecting hybrid individuals under different hybridization scenarios and with different numbers of loci. *Molecular Ecology*, 15:63-72.
- PRITCHARD, J K, STEPHENS, M & P. DONNELLY. 2000. Inference of population structure using multilocus genotype data. *Genetics*, 155: 945-59.
- ROUSSET, F. 2008. genepop'007: a complete re-implementation of the genepop software for Windows and Linux. *Molecular ecology resources*, 8: 103-106.
- SACKS, B. N., M. MOORE, M. J. STATHAM, AND H. U. WITTMER. 2011. A restricted hybrid zone between native and introduced red fox (*Vulpes vulpes*) populations suggests reproductive barriers. *Molecular Ecology* 20:326-341.
- SAX, D.F., STACHOWICZ, J.J., BROWN, J.H., BRUNO, J.F., DAWSON, M.N., GAINES, S.D., GROSBERG, R.K., HASTINGS, A., HOLT, R.D., MAYFIELD, M.M. AND M.I. O'CONNOR. 2007. Ecological and evolutionary insights from species invasions. *Trends in Ecology & Evolution*, 22: 465-471.
- STATHAM, M. J., B. N. SACKS, K. B. AUBRY, J. D. PERRINE, AND S. M. WISELY. 2012. The origin of recently established red fox populations in the United States: translocations or natural range expansions? *Journal of Mammalogy*, 93:52-65.
- SZPIECH, Z.A., JAKOBSSON, M., AND N. ROSENBERG. 2008. ADZE: a rarefaction approach for counting alleles private to combinations of populations. *Bioinformatics*, 24: 2498-2504.
- TOEWS, D. P., AND A. BRELSFORD. 2012. The biogeography of mitochondrial and nuclear discordance in animals. *Molecular Ecology*, 21: 3907-3930.

WILSON, R.J., DAVIES, Z.G. AND C. D. THOMAS. 2009. Modelling the effect of habitat fragmentation on range expansion in a butterfly. *Proceedings of the Royal Society of London B: Biological Sciences* 276: 1421-1427.

Chapter 5

Conclusions

And

The Origins of Red Foxes in eastern United States

The global redistribution of species by humans has had significant impacts on native biota (Genton et al 2005; Ricciardi 2007; Kirk et al 2011; LeRoux et al 2011). The impacts have been negative, from species eradication to genetic homogenization (Wilson et al 2009). However, positive results can arise when introduced species (or recently expanded species) hybridize, including increased population fitness and speciation (Abbot et al 2013). Fortunately, new molecular tools and advances in theory and analysis allow for deeper investigations into introductions and expansions. These can, in turn, advance evolutionary theory and provide strategies for dealing with population declines and climate change.

Red foxes were first recognized in the eastern United States in the mid-18th century. At the onset of European colonization of North America they were believed to occur above 40-45°N latitude and were “scarce or absent from the unbroken mixed hardwood” where grey foxes occurred (Churcher 1959). As Europeans razed forests and changed the habitat for agricultural purposes, red foxes from northern populations in eastern Canada expanded their range south (Audubon and Bachman 1849; Rhodes 1908; Churcher 1959). There were simultaneous reports of introductions of red foxes from Europe (Frey 2013). Subsequently, it became established that the red foxes in eastern United States were invasive populations that had expanded across the continent and were threatening native populations (Kamler and Ballard 2002). However, this hypothesis was shown to be incorrect as no European mitochondrial markers were found in a survey of foxes in central United States (Statham et al 2012).

In this study I addressed the origins of red foxes in the eastern portion of the United States. This study extended geographically from Vermont to North Carolina and western New York to the Delmarva Peninsula. I used a molecular approach to answer the broad question, what are the origins of red foxes in eastern United States? In answering this question, I also

explored questions regarding the impacts of introduced species and the effects of the landscape in shaping the population structure throughout the study region. Here, I address each of these questions in regards to the study as a whole.

What are the origins of the red fox in eastern United States?

Although this study confirms European red foxes were introduced to the mid-Atlantic region of North America, their limited geographic range and absence in Appalachian populations demonstrates they are not the sole source of red foxes in the region. Mitochondrial DNA identified native Canadian haplotypes and fur-farmed individuals also contributed to the foundation of populations. The widespread nature of the F3-9 haplotype in eastern United States samples, including historical Georgia, and its absence in samples north of the Hudson lowlands is consistent with a late Holocene or historical population expansion. These findings suggest that red foxes were indigenous to the eastern United States prior to or during colonial times.

Relatively low nuclear genetic structure - despite geographic distance and potentially impactful landscape features – suggests either a recent expansion or strong admixture due to high gene flow. The most parsimonious explanation for the sum total of these findings is that red foxes were absent south of New England at the time of European colonization and, because of this vacuum, and changes in the colonial landscape (e.g., removal of wolves, reduction of gray-fox favored habitat, climatic cooling), native red foxes expanded south along the Appalachian Range. The reduction in allelic richness with increasing distance from the source population supports a recent expansion, as dispersing alleles undergo bottlenecks which reduce the overall number of alleles. These populations expanded beyond the Appalachian Range into the lowland valley regions where they combined with foxes from introduced European and fur-farm

populations. Interestingly, mitochondrial and Y chromosome markers pinpointed the region of origin of these foxes to Britain and Ireland.

What is the geographic extent of introduced European foxes?

The low diversity of maternal and paternal haplotypes from European sources is consistent with a single successful introduction of as few as 3 individuals. The region-wide dispersion of European haplotypes and the sharing of a single Y chromosome haplotype among 3 distinct locations suggests a many generational timeline of introduction consistent with colonial origins. European haplotypes of either sex appear geographically limited to the human dominated landscapes in the low-land regions of the study area. Although British haplotypes exist west of the Appalachian Mountain Range, it is in the Hudson valley which is connected to the mid-Atlantic lowland corridor by the Delaware Watershed Gap, and in an area with heavy fur farm influence suggesting human-mediated transport could also have played a role in their establishment there.

Has native range expansion or human-mediated introduction played a bigger part in the establishment of red foxes in eastern United States?

Given that several sampling sites in the present study had no European haplotypes and few to no unambiguous fur farm haplotypes, our results support Frey's conclusion that these most likely derived from indigenous foxes. The native F3-9 haplotype was present in 16/18 sampling locations supporting an historic range expansion. Mitochondrial haplotypes, however, confirm the influence of both introduced British and fur-farm individuals and non-native admixture clearly had significant impact on population diversity. In general, non-native

populations can be introduced into two basic scenarios: 1) habitats without conspecifics and 2) habitats with conspecifics. The first scenario would result in founder effects and strong genetic drift resulting in reduced genetic diversity. The second scenario, would cause high admixture, outbreeding, and an increase in genetic diversity. Population structure would depend on the pre-existing differentiation and levels of gene flow. In our study, genetic diversity was highest at mid-latitudes due to having the highest admixture among the three sources (native, European, fur-farm). South of VT, individuals were assigned to multiple genetic groups with admixture proportions ranging 20–80%. Thus, as indicated previously with mitochondrial DNA, introductions from Europe and fur farms apparently also increased the nuclear genetic diversity of the Eastern red fox south of the known historical range. However, it seems that these introductions merely contributed diversity to the red fox populations already undergoing range expansion. However, it is impossible to say whether the natural range expansion would have succeeded without those introductions or vice versa. Most likely, it was landscape dependent as the findings presented are similar to findings in the western United States. In those populations nonnative red foxes (in that case, solely from fur farms) also appear to be associated closely with human-dominated landscapes and, perhaps, less able to thrive in more remote habitats, where their native counterparts predominate (Churcher 1959; Sacks et al 2010, 2011; Statham et al 2012; Frey 2013; Volkmann et al 2015).

How has the landscape, specifically the Appalachian Mountain Range, impacted the distribution of red foxes in eastern United States?

The nuclear genetic results repeatedly show the Appalachian Mountains served as a corridor facilitating southward gene flow from the northern native source. In particular, I

demonstrate the differential patterns of native vs. nonnative expansion related to habitat. While this pattern surfaced in all markers tested, significant correlations and isolation by resistance are consistent with higher connectivity across sampling sites within the Appalachian range. For example, the VT site was most closely related to the location furthest from it, SO, also within the Appalachians. Although the Appalachians apparently served to facilitate native gene flow, there was no evidence to suggest these mountains served as a barrier to non-native gene flow. The landscape resistance model was not a significant predictor of genetic distance among lowland populations. More directly, the AMOVAs that predicted a division between mountain and lowland populations were not significant and admixture profiles were nearly identical between central latitude sites in and out of the Appalachians. Thus, while the Appalachians historically acted as a corridor for expansion and may still, they are not a barrier for gene flow between populations in the lowland regions and those in the Appalachians.

What is the extent of introgression from British red foxes?

Our finding that individuals exhibiting a European haplotype (from its maternal or paternal side) also exhibited a North American haplotype from the other parent (in every case) clearly indicated that the 2 nominal species bred in the past and produced fertile offspring. Interestingly, however, the prevalence of mitochondrial European haplotypes was nearly an order of magnitude higher than that of European Y chromosomes. While this pattern could reflect a greater number of female than male founders from Europe, this seems unlikely given evidence from the Australian introductions and anecdotes of the North American introductions (Long 2003; Frey 2013). When foxes were introduced, they would likely have been introduced as breeding pairs to facilitate population growth. One explanation is Haldane's rule, "when in

the offspring of two different animal races one sex is absent, rare, or sterile, that sex is the [heterogametic] sex” (Haldane 1922). In this case, male hybrid offspring are less viable than female offspring resulting in the continuance of European mitochondrial genome but not the Y genome. This is supported by recently described evidence of a continental exchange of mitochondrial but not Y chromosome lineages from Asian to Alaskan red foxes across the Bering land bridge during the last Pleistocene glaciation (Statham et al 2014). On the other hand, predictions of introgression expect higher introgression to occur among markers of the less dispersing sex while those of the more dispersing sex are swallowed by the native population. This is because reduced conspecific gene flow at the expansion front (Currat 2008). Although red foxes have a broad range of behavioral phenotypes when it comes to dispersal and mating, typically males have a higher rate of dispersal (Allen and Sargeant 1993).

Interestingly, the picture provided by the nuclear genetic analysis contrasts with findings from mitochondrial DNA. Despite the heavy presence of British mitochondrial haplotypes and the proven ability to produce fertile offspring, there is little evidence of introgression of nuclear genes from introduced foxes to native ones. Though mito-nuclear discordance is a common occurrence in animal systems, the causes of it are not often understood (Toews and Brelsford 2012). The most likely explanation for our results is nuclear introgression occurred in the direction of native into introduced (Currat et al 2008). This is because as introduced genes disperse into the native range, there are a limited number conspecifics with whom to mate. When they hybridize with the native species, subsequent backcrossing is exclusively with the natives and eventually the introduced markers are swamped. With mitochondrial markers, however, non-dispersing genes increase under genetic drift and gradually introgress into the

native population. In our case, mitochondrial DNA from British ancestors was able to migrate as far inward as western New York but the nuclear genome was swamped by the native population.

In conclusion, while mitochondrial markers may provide greater insight into the history of red foxes in the mid-Atlantic United States, the Y markers and nuclear markers reveal the current reality: introduced British red foxes have had little impact on the population and the remnants of the introductions will likely be lost over time.

LITERATURE CITED

- ABBOTT, R., ALBACH, D., ANSELL, S., ARNTZEN, J. W., BAIRD, S. J. E., BIERNE, N., BOUGHMAN, J., BRELSFORD, A., BUERKLE, C. A., BUGGS, R., BUTLIN, R. K., DIECKMANN, U., EROUKHMANOFF, F., GRILL, A., CAHAN, S. H., HERMANSEN, J. S., HEWITT, G., HUDSON, A. G., JIGGINS, C., JONES, J., KELLER, B., MARCZEWSKI, T., MALLET, J., MARTINEZ-RODRIGUEZ, P., MÖST, M., MULLEN, S., NICHOLS, R., NOLTE, A. W., PARISOD, C., PFENNIG, K., RICE, A. M., RITCHIE, M. G., SEIFERT, B., SMADJA, C. M., STELKENS, R., SZYMURA, J. M., VÄINÖLÄ, R., WOLF, J. B. W. AND D. ZINNER. 2013. Hybridization and speciation. *Journal of Evolutionary Biology*, 26: 229–246
- AUDUBON, J. J., AND J. BACHMAN. 1849. The viviparous quadrupeds of North America. Privately published by J.J. Audubon, New York. Vol. 2.
- ALLEN, S.H. AND A.B. SARGEANT. 1993. Dispersal patterns of red foxes relative to population. *The Journal of Wildlife Management*, 57: 526-533.
- CHURCHER, C. S., 1959. The Specific Status of the New World Red Fox. *Journal of Mammology* 4:513–520.
- Currat, M., Ruedi, M., Petit, R. J. and L. Excoffier. 2008. The hidden side of invasions: massive introgression by local genes. *Evolution*, 62: 1908-1920
- FREY, J. K. 2013. Re-evaluation of the evidence for the importation of red foxes from Europe to colonial America: Origins of the southeastern red fox (*Vulpes vulpes fulva*). *Biological Conservation* 158:74-79.
- GENTON, B. J., SHYKOFF, J. A., AND T. GIRAUD. 2005. High genetic diversity in French invasive populations of common ragweed, *Ambrosia artemisiifolia*, as a result of multiple sources of introduction. *Molecular Ecology* 14:4275-4285.
- HALDANE, J. B. S. 1922. Sex ratio and unisexual sterility in hybrid animals. *Journal of Genetics*, 12: 101–109.
- KAMLER, J. F., AND W. B. BALLARD. 2002. A review of native and nonnative red foxes in American. *Wildlife Society Bulletin*, 30:370–379.
- KIRK, H., PAUL, J., STRAKA, J. AND J. R. FREELAND. 2011. Long-distance dispersal and high genetic diversity are implicated in the invasive spread of the common reed, *Phragmites australis* (Poaceae) in northeastern North America. *American Journal of Botany*, 98:1180-1190.
- LE ROUX, J. J., BROWN, G. K., BYRNE, M., NDLOVU, J., RICHARDSON, D. M., THOMPSON, G. D. AND J. R. U. WILSON. 2011. Phylogeographic consequences of different introduction histories of invasive Australian *Acacia* species and *Paraserianthes lophantha* (Fabaceae) in South Africa. *Diversity and Distributions*, 17:861-871.

- LONG, J. 2003. Introduced mammals of the world: their history, distribution and influence. CSIRO Publishing, Melbourne, Australia.
- RHODES, S.N. 1908. The mammals of Pennsylvania and New Jersey. Privately Published, Philadelphia.
- RICCIARDI, A. 2007. Are modern biological invasions an unprecedented form of global change? *Conservation Biology*, 21:329-336.
- STATHAM, M. J., SACKS, B. N., AUBRY, K. B., PERRINE, J. D. AND S. M. WISELY. 2012. The origin of recently established red fox populations in the United States: translocations or natural range expansions? *Journal of Mammalogy*, 93:52–65.
- STATHAM, M. J., MURDOCH, J., JANECKA, J., AUBRY, K. B., EDWARDS, C., SOULSBURY, C. D., BERRY, O., WANG, Z., HARRISON, D., PEARCH, M., TOMSETT, L., CHUPASKO, J., AND B. N. SACKS. 2014. Range-wide multilocus phylogeography of the red fox reveals ancient continental divergence, minimal genomic exchange and distinct demographic histories. *Molecular Ecology*, 23:4813-4830.
- TOEWS, D. P., AND A. BRELSFORD. 2012. The biogeography of mitochondrial and nuclear discordance in animals. *Molecular Ecology*, 21: 3907-3930.
- WILSON, J.R.U., DORMONTT, E.E., PRENTIS, P.J., LOWE, A.J. AND D.M. RICHARDSON. 2009. Something in the way you move: dispersal pathways affect invasion success. *Trends in Ecology and Evolution*, 24: 136-144.

APPENDIX

Letters from B.N. Sacks and M.J. Statham to the Dean of the Graduate School granting approval for their co-authored article(s) to be used as portions of this dissertation.

UNIVERSITY OF CALIFORNIA, DAVIS

UNIVERSITY OF CALIFORNIA • DAVIS • CALIFORNIA • 95616 • PHOENIX • 602 • 855-0800



SAN JUAN • 408 • SAN JUAN • 408

VETERINARY CLINICAL EMPOZALOMY
SCHOOL OF VETERINARY MEDICINE
TELEPHONE 530-754-2911
FAX 530-754-2088

CONSULTING OFFICE
DAVIS, CALIFORNIA 95616

Benjamin N. Sacks, Ph.D., Associate Adjunct Professor, Director
Mammalian Ecology and Conservation Unit
530-754-9088
bnsacks@ucdavis.edu

Graduate School
1004A Administration Annex
University of New Orleans
2000 Lakeshore Drive

March 14, 2016

To the Graduate School at the University of New Orleans:

I hereby authorize Adrienne E. Kasprovicz use the following papers, which I co-authored, in her doctoral dissertation: (1) "Fate of the other redcoat: remnants of colonial British foxes in the Eastern United States," published in the *Journal of Mammalogy*, and (2) "History of the native red fox in the eastern United States: identifying the impacts of spatial expansion and translocation on the structure of a mobile generalist," submitted and currently under review for publication.

Sincerely,

A handwritten signature in black ink, appearing to read "Benjamin Sacks", written over a light-colored rectangular background.

UNIVERSITY OF CALIFORNIA, DAVIS

BERKELEY • DAVIS • IRVINE • LOS ANGELES • MERCED • RIVERSIDE • SAN DIEGO • SAN FRANCISCO



SANTA BARBARA • SANTA CRUZ

VETERINARY GENETICS LABORATORY
SCHOOL OF VETERINARY MEDICINE

ONE SHIELDS AVENUE
DAVIS, CALIFORNIA 95616-8744

Veterinary Genetics Laboratory
University of California
One Shields Avenue/Old Davis Rd.
Davis, California 95616-8744

To:
Graduate School
1004A Administration Annex
University of New Orleans
2000 Lakeshore Drive
New Orleans, LA 70148

March 14th 2016

To the Graduate School at the University of New Orleans:

I give my permission that Adrienne E. Kasprovicz use our co-authored paper (Fate of the other redcoat: remnants of colonial British foxes in the Eastern United States) in her doctoral dissertation.

Regards,

Mark Statham, Ph.D.

VITA

Adrienne E. Kasproicz was born in Alexandria, Virginia. She received her B.S. from The University of Virginia with a concentration in conservation. She joined Dr. Johnson's evolutionary biology lab at UNO where she mastered DNA extraction from all forms of matter. She currently lives in Philadelphia, Pennsylvania with her husband, Eric and their dog, Thibodaux.